

Regular Board of Education Meeting
Wednesday, January 2, 2013 7:00 PM Eastern

Central Services
15-B North Granby Road
Granby, CT 06035

Jenny Emery: Present
Lynn Guelzow: Present
Cal Heminway: Present
Edward Ohannessian: Present
Benjamin Perron: Present
Ronald Walther: Present
Rosemarie Weber: Present
Present: 7.

I.	Public Comment
II.	Administrative Reports
II.A.	Superintendent's Announcements
II.B.	Student Representative Reports
II.C.	Schools in the Spotlight
III.	Consent Agenda
III.A.	Minutes
III.B.	Retirements
IV.	Old Business
IV.A.	FY14 Budget Goals
V.	New Business
V.A.	First Reading of Policies 4118.11, Personnel - Non-Discrimination; 5145.4, Students - Non-Discrimination; and, 1110.1 Community Relations
V.B.	FY14 Plus One Budget
VI.	Miscellaneous
VI.A.	Board Standing Committee Reports
VI.A.1.	Curriculum/Policy/Technology/Communication
VI.A.2.	Finance/Personnel/Facilities
VI.B.	Other Board-Related Reports
VI.B.1.	Athletic Field Project Committee
VI.B.2.	CREC/CABE
VI.B.3.	Granby Education Foundation
VI.B.4.	District Efficiency Initiatives
VI.C.	Calendar of Events
VI.D.	Board Member Announcements
VII.	Executive Session/Non-Meeting

**Regular Board of Education Meeting – Approved Minutes
December 5, 2012, 7:00 p.m.
Central Services**

Attendance was taken at 6:45 p.m.

Present Board Members:

Jenny Emery
Lynn Guelzow
Cal Heminway
Edward Ohannessian
Benjamin Perron
Mr. Ronald Walther
Rosemarie Weber

Mr. Heminway called the meeting to order at 7:00 p.m.

I. Public Comment

There were no public comments this evening.

II. Administrative Reports

II.A. Superintendent's Announcements

- Special welcome to Wells Road students, parents and staff members.
- Welcome to Patrick Flynn from Revision learning who will be presenting on the new teacher and administrator evaluation plans for this upcoming fall.
- A reminder that any information presented this evening can also be found on-line.
- Congratulations to Kelsey Iwanicki and Colleen Leonardi for receiving the NFHCA High School National Academic Squad Award. Kelsey and Colleen met the criteria by being members of the varsity field hockey team and attaining a cumulative GPA of 3.5 out of 4.0 through the first quarter of the 2012-2013 academic year.
- Congratulations to Peter Brodeur and Michael Spence for receiving the Farmington Valley Superintendents' Award this past Friday.
- There are a variety of season activities being held this month. Please visit the school websites for details.
- A focus group meeting will take place on Wednesday, December 12th for ongoing discussions on the intermediate school reconfiguration. Eight (8) parents will be invited to represent the larger parent group. A meeting will also be held with teachers on Thursday, December 13th.
- We look forward to discussing 1-to-1 computing again in January and to make a recommendation to the Board. The Board should send any other comments or questions to the superintendent.
- Site budget meetings continue to move forward. We are working as close as we can with Board of Finance guideline of a 2% budget increase.
- This is the last Board of Education meeting before the winter vacation. The next board meeting will be held on January 2, 2013.
- There was an article in today's paper with regard to the Connecticut State Department of Education school performance index. Schools will be ranked from 1 to 100. Mr. Ed Lyman will present this topic to the Board this evening.
- Happy Holidays and Season's Greetings to all students, staff and families on behalf of the Board.

II.B. Student Representative Reports

- Boys' and girls' basketball have had their first games; ice hockey has their first game this Saturday; and, swimming has their first meet on the 14th
- Model UN visited the UN in New York City today.
- Graduation night committee meeting is on December 10th.
- The select choir will be signing at the Wadsworth Athenaeum.
- Chorus is getting ready for their December 14th concert
- National Honor Society is hosting their annual stocking drive to give small gifts and toys to local children this holiday season.
- The middle school is putting on their annual cabaret fall drama production this Friday evening.

II.C. Business Manager's Report

Mr. Traver, Business Manager, presented the November statement of accounts. There is not a lot of change since last month's report was presented last week. Special education costs have increased by \$38K from the last report based on two new students. We are \$6K unfavorable for full year. The statement of accounts was reviewed by the Finance Subcommittee this evening.

II.D. Schools in the Spotlight

Dr. Anna Forlenza-Bailey and Ms. Kathy Waddington, Technology Teacher introduced students from Wells Road who made a presentation to the Board on how they "solved problems by asking questions."

II.E. Guidance Presentation

Julie Bragg and Sheridan Toomey, Guidance Counselors at the High School, presented information and background of the service delivery model for guidance at the high school. Ms. Toomey spoke about the developmental guidance curriculum and Ms. Bragg shared data about outcomes of students' post-secondary plans and how the department is looking at different vehicles to track past graduates and their post-secondary graduation rates. The Board requested additional information on the number of students applying to top tier schools, and the acceptance trends over the past few years. For the future, the Board would like to see information about non-college bound students (coop programs, internships, etc.) included in the presentation.

II.F. Teacher Evaluation Plan

Mr. Patrick Flynn, consultant with Revision Learning Partnership, made a presentation on the Core Components of the new Teacher/ Administrator Evaluation Program. Mr. Flynn also provided a progress report on the development of Granby's teacher evaluation program that he is facilitating with teachers and administrators. The district must submit their plans to the state by April 15th. Mr. Addley stated that the Board will see FY14 budget requests to support teacher and student data systems.

III. Consent Agenda

III.A. Minutes

A motion was made by Ed Ohannessian and seconded by Jenny Emery to adopt the consent agenda. This motion passed unanimously at 8:50 p.m.

IV. New Business

IV.A. Election of Board Vice Chairman

Ron Walther nominated Ed Ohannessian for Board Vice Chairman. A motion was made by Ron Walther and seconded by Ben Perron to accept Ed Ohannessian's nomination as Board Vice Chairman. This motion passed unanimously at 8:52 p.m.

IV.B. FY14 Budget Goals

Draft budget goals were discussed. The Board discussed the development of strategic goals. Some Board members expressed a desire to see goals that addressed the needs of the gifted and talented students. Mr. Addley stated that this would be assumed under budget goal #1 and that it is therefore included as part of the Board goals for the year and his own his goals. The Board expressed a desire to more thoroughly explore this topic, including what is currently being done for students who already know and have mastered the material. A suggestion was made to change the word "Maintains" to either "Provides" or "Ensures" for goal #3. The Board will vote on the budget goals at the next meeting.

IV.C. CPPAC Report

Mr. Addley presented an updated capital project priority draft, for review in advance of it being submitted to CPPAC. Of note and #1 priority in the package is additional land, and a maintenance facility building, technology upgrade, and an emergency generator. The Board will review the draft and it will come back to the Board at the next meeting.

IV.D. School Performance Index

Mr. Ed Lyman presented to the Board the state's new accountability system called the School Performance Index (SPI). Mr Lyman explained how the new system works and the differences between the new system and the old NCLB (No Child Left Behind) accountability system. More information will be published next week as to school/district rankings. All of Granby's schools exceeded the state's SPI benchmark of 88, and Kelly Lane School was recognized as a school of distinction for overall student performance and students with disabilities.

There was no old business to report this evening.

VI. Miscellaneous

VI.A. Board Standing Committee Reports

VI.A.1. Curriculum/Policy/Technology/Communication

This Subcommittee met this evening. Several policies were reviewed. A nondiscrimination policy will be brought forward to the Board in January and a community relations policy will also come to the Board for review after a few revisions. The IEP policy and the advertising policy require a longer discussion. Also discussed: professional development in the district; positive school climate; work with writing review analysis K-12; and new texts: two English textbooks as well as Text for Mandarin Chinese IV.

VI.A.2. Finance/Personnel/Facilities

This Subcommittee met this evening. Bill Arnone, 11th grader and Eagle Scout, presented his Eagle Scout project to re-do the trails at Kearns. The Subcommittee endorsed the project. The Committee also discussed the November statement of accounts; CPPAC which will be discussed at a future meeting; and, two potential solar projects.

VI.B. Other Board-Related Reports

VI.B.1. Athletic Field Project Committee

Mr. Perron reported that bids are due back next Wednesday, December 12th and there will be a meeting that evening to review and select a contractor. There is a request from the committee for Board input on a more complete housing solution for the electrical equipment, which was not in the original specifications. The Board requested the committee advise what it envisions for this structure, as well as an approximate cost.

VI.B.2. CREC/CABE

VI.B.3. Granby Education Foundation

VI.B.4. District Efficiency Initiatives

Tom Steinke met with a company that specializes with engineered energy efficiency. This company works in a few towns around Connecticut (Region 14, Avon). After reviewing our usage per square foot we were advised that Granby would not benefit from their services. We are still working on the lighting revamping project.

VI.C. Calendar of Events

The calendar of events is as presented.

VI.D. Board Member Announcements

Mr. Addley stated he hopes that the Board can attend the holiday get-together.

VII. Executive Session/Non-Meeting

There was no Executive Session/Non-Meeting this evening. A motion was made by Jenny Emery and seconded by Rosemarie Weber to adjourn the meeting. This motion passed unanimously at 9:41 p.m.

Jenny Emery, Board Secretary

Linda Powell, Board Recorder

To: Board of Education
From: Alan Addley, Superintendent
Date: January 2, 2013
Re: FY14 BOE Budget Goals

Each year the Board of Education adopts goals to help serve as a guide in the budget development process and a framework for the budget book. These goals are used for the operating budget, quality and diversity fund and the Educational Capital Improvement fund requests. Pursuant to our discussion about the FY14 budget, the following are suggested goals for Board adoption that would be used to guide the budget development process.

To develop a budget that:

1. Supports the vision, mission, values, and goals of the district;
2. Recognizes the economic climate, realizes efficiencies and is responsive to the financial guidelines set by the Board of Finance;
3. Provides levels of personnel, programs, infrastructure, and services that meet the essential needs of the district;
4. Addresses High School Reform, Common Core Standards and Teacher/Administrator Evaluation; and,
5. Supports Board studies (World Languages, 1-1 computing; intermediate schools, interventions for students & PLC time).

Community Relations

Communications with the Public

Parent Involvement

Aligned with our district mission to foster effective collaboration, the Granby Board of Education (BOE) believes that improved student achievement is the shared responsibility and goal of the BOE, parents, teachers, the school system and the community at large. Research supports our belief that the education of our children must be a collaborative effort between families and school, and that meaningful cooperation and effective communication between home and school improve the quality of education significantly. Consistent and two-way communication and cooperation between teachers and parents, including guardians and other family members involved in supervising children's education, improves student behavior and attendance and, ultimately, achievement.

Therefore, all parents, guardians and care-givers of students in our schools are encouraged to take an active role in the education of their children, and school personnel will ensure a variety of opportunities for parents to participate in the life of the school community. The opportunities provided by each school are in no way a limit on the ways in which parents can and should be involved in their child's education. Each school will develop an annual plan to foster opportunities for parent and family involvement and participation including, but not limited to, such steps as ensuring that:

- Parents and guardians are welcome in every school and their support, assistance and input is sought in assisting student learning.
- Communication between home and school is regular, two-way, meaningful and consistent, and reflects updated and accurate information.
- Systems of communication are developed and refined to meet the needs of all our families including those from other communities.
- Conference schedules respect the needs of working families.
- Community resources are made available to strengthen school programs and student learning.
- Opportunities are provided for parents to give input regarding decisions affecting children and families.
- Opportunities for parent and community involvement foster shared responsibility for student learning.

The Superintendent will report to the Board of Education annually on parent involvement opportunities.

Legal Reference: Connecticut General Statutes
10-221(f) Boards of Education to prescribe rule(s), policies, and procedures as amended by PA 97-290 and by P.A. 10-111, An Act Concerning Education Reform in Connecticut

Policy adopted:

GRANBY PUBLIC SCHOOLS
Granby, Connecticut

Personnel – Certified/Non-Certified

Nondiscrimination

The Granby Board of Education will not make employment decisions (including decisions related to hiring, assignment, compensation, promotion, demotion, disciplinary action and termination) on the basis of race, color, religion, age, sex, marital status, sexual orientation, national origin, ancestry, disability, pregnancy, genetic information, or gender identity or expression, except in the case of a bona fide occupational qualification.

It is the policy of the Granby Board of Education that any form of discrimination or harassment on the basis of race, religion, color, national origin, sex, sexual orientation, marital status, age, disability, pregnancy, or gender identity or expression is prohibited, whether by students, Board employees or third parties subject to the control of the Board. The Board's prohibition of discrimination or harassment in its educational programs or activities expressly extends to academic, nonacademic and extracurricular activities, including athletics. It is also the policy of the Board of Education to provide for the prompt and equitable resolution of complaints alleging any discrimination on the basis of protected characteristics such as race, color, religion, age, sex, sexual orientation, marital status, national origin, disability (including pregnancy), or gender identity or expression.

For the purposes of this policy, "genetic information" means the information about genes, gene products, or inherited characteristics that may derive from an individual or a family member. "Genetic information" may also include an individual's family medical history, the results of an individual's or family member's genetic tests, the fact that an individual or an individual's family member sought or received genetic services, and genetic information of a fetus carried by an individual or an individual's family member or an embryo lawfully held by an individual or family member receiving assistive reproductive services.

Legal References:

- Title VI of the Civil Rights Act of 1964, 42 U.S.C. § 2000d *et seq.*
- Title VII of the Civil Rights Act of 1964, 42 U.S.C. § 2000e *et seq.*
- Title IX of the Education Amendments of 1972, 20 USCS § 1681, *et seq.*
- Age Discrimination in Employment Act, 29 U.S.C. § 621
- Americans with Disabilities Act, 42 U.S.C. § 12101
- Section 504 of the Rehabilitation Act of 1973, 29 U.S.C. § 794
- Title II of the Genetic Information Nondiscrimination Act of 2008, Pub.L.110 233, 42 USC 2000ff; 34 CFR 1635
- Connecticut General Statutes § 10-153. Discrimination on basis of marital status

Personnel – Certified/Non-Certified

Nondiscrimination (Cont'd)

Connecticut Fair Employment Practices Act, Connecticut General Statutes § 46a-60

Connecticut General Statutes § 46a-81a Discrimination on basis of sexual orientation: Definitions

Connecticut General Statutes § 46a-81c Sexual orientation discrimination: Employment.

Policy adopted:

GRANBY PUBLIC SCHOOLS
Granby, Connecticut

Draft

Students

Nondiscrimination

The Granby Board of Education complies with all applicable federal, state and local laws prohibiting the exclusion of any person from any of its educational programs or activities, or the denial to any person of the benefits of any of its educational programs or activities because of race, religion, color, national origin, sex, sexual orientation, marital status, age, disability, pregnancy, or gender identity or expression, subject to the conditions and limitations established by law.

It is the policy of the Board that any form of discrimination or harassment on the basis of race, religion, color, national origin, sex, sexual orientation, marital status, age, disability, pregnancy or gender identity or expression is prohibited, whether by students, Board employees or third parties subject to the control of the Board. The Board's prohibition of discrimination or harassment in its educational programs or activities expressly extends to academic, nonacademic and extracurricular activities, including athletics. It is also the policy of the Board to provide for the prompt and equitable resolution of complaints alleging any discrimination on the basis of protected characteristics such as race, color, religion, age, sex, sexual orientation, marital status, national origin, disability, pregnancy, gender identity or expression.

For the purposes of this policy, "gender identity or expression" means a person's gender-related identity, appearance or behavior, whether or not that gender-related identity, appearance or behavior is different from that traditionally associated with the person's physiology or assigned sex at birth, which gender-related identity can be shown by providing evidence including, but not limited to, medical history, care or treatment of the gender-related identity, consistent and uniform assertion of the gender-related identity or any other evidence that the gender-related identity is sincerely held, part of a person's core identity or not being asserted for an improper purpose.

Legal References:

Title IX of the Education Amendments of 1972, 20 U.S.C. § 1681, *et seq.*
Title VI of the Civil Rights Act of 1964, 42 U.S.C. § 2000d, *et seq.*
Americans with Disabilities Act, 42 U.S.C. § 12101, *et seq.*
Connecticut General Statutes § 10-15c and § 46a-81a, *et seq.* - Discrimination on
basis of sexual orientation
Section 504 of the Rehabilitation Act of 1973, 29 U.S.C. § 794, *et seq.*

Policy adopted:

GRANBY PUBLIC SCHOOLS
Granby, Connecticut

Students

Nondiscrimination

Students, parents, employees, applicants for positions and other third parties may not be denied the right to participate in a publically funded educational setting based on the following protected classes: race, color, religion, sex, gender identification or expression, national origin, age, disability, marital status, pregnancy, and/or genetic information.

If you are a STUDENT, you may not be discriminated against based on the above categories, including in the following areas:

- Admission
- Use of School Facilities
- Vocational Education
- Competitive Activities
- Student Rules, Regulations and Benefits
- Financial Assistance
- School-Sponsored Extracurricular Activities
- Enrollment in Courses
- Counseling and Guidance
- Physical Education
- Graduation Requirements
- Treatment as a Married and/or Pregnant Student
- Health Services
- Most Other Aid, Benefits or Services

If you are an EMPLOYEE, you may not be discriminated against based on the above categories, including in the following areas:

- Hiring and Promotion
- Compensation
- Job Assignments
- Leave of Absence
- Fringe Benefits
- Labor Organization
- Contracts or Professional Agreements

The purpose of this procedure is to secure, at the lowest possible administrative level, timely equitable solutions to problems which may arise concerning claims of discrimination on the above bases. If you believe that you have been discriminated against, or witnessed discrimination in regard to any of the preceding policies, you may file a grievance regarding any rights believed to have been denied or violated. A report of complaint should be made within 180 days of the alleged discrimination. Grievance Forms are available from Human Resources, Compliance Coordinators, The Director of Pupil Personnel Services, Building Principals/ Administrators, and Guidance Offices. Forms may also be found on the Granby Public Schools website www.granby.k12.ct.us. If needed, assistance will be provided when filing a complaint.

Students

Nondiscrimination (Cont'd)

Any individual who wishes to inquire or to register a complaint concerning alleged discrimination in the Granby Public Schools shall have an opportunity to bring such concerns to the attention of the Compliance Coordinator (s) who are the Human Resources Coordinator, the Title IX Coordinators, the Director of Pupil Personnel, the Building Principal/Administrator, or the Superintendent who have the authority to resolve such complaints.

- **For Student/Parent-Guardian/Employee/Applicant Complaints Involving Alleged Discrimination on the Basis of Gender [Title IX] Contact the following Compliance Coordinators:**

Jessica Beecher

Primary Level
FM Kearns Primary
860.844.3044
beecherj@granby.k12.ct.us
macdonaldh@granby.k12.ct.us

Heidi MacDonald

Intermediate Level
Wells Road Intermediate
860.844.3048

Sue Vacek

Middle School Level
Granby Memorial Middle School
860.844.3029
vaceks@granby.k12.ct.us

Sheri Barnett

High School Level
Granby Memorial High School
860.844.3014
barnetts@granby.k12.ct.us

- **For Student/Parent-Guardian/Employee/Applicant Incidents Involving Discrimination on the Basis of a Disability [Section 504] Contact:**

Aimee Martin

Director of Pupil Personnel Services
Granby Board of Education Central Office
860.844.5255
martinad@granby.k12.ct.us

- **For Employer/Employee Incidents Involving Discrimination on the Basis of all other Protected classes, Contact:**

Karen Walther
Human Resources Coordinator
Granby Board of Education Central Office
860.844.5264
waltherk@granby.k12.ct.us

Administrative Regulations 5145.4(c)

Students

Nondiscrimination (Cont'd)

- **For Student Incidents Involving Discrimination on the Basis of all other Protected classes, Contact:**

Building Principal

While complaints are being investigated, the safety of all parties will be ensured. Once a complaint has been received, interim measures such as counseling, stay away mechanisms, and/or academic adjustments may be utilized. All proceedings shall be kept confidential as is appropriate and if discrimination is found, steps will be taken to promptly and effectively end the discrimination, prevent its reoccurrence, and remedy its effects. In determining if discrimination occurred, a preponderance of evidence will be used. All parties will be notified of the outcome of the investigation subject to the District's legal responsibilities to comply with the Family Educational Rights and Privacy Act (FERPA) 20 U.S.C. § 1232g. Evidence of reprisal or retaliation against any party shall be viewed as an infraction of the policy and will not be tolerated.

In compliance with regulations of Title VI, Title VII of the Civil Rights Act of 1964, Title IX of Education Amendments of 1972 and Section 504 of the Rehabilitation Act of 1973, Title II of the Americans with Disabilities Act and the Civil Rights act of 1987, the Granby Board of Education adopts the following Equal Employment Opportunity and Equal Educational Opportunity Policies.

The following grievance procedure shall be utilized by any student, parent/guardian, employee, or applicant in making a complaint or inquiry.

Level I: Early Complaint Resolution [*Informal Resolution Mechanism*]

Early Complaint Resolution allows the parties (the complainant and the individual who caused the alleged discrimination) an opportunity to resolve the alleged discrimination quickly. If both parties are willing to try this approach, and if the Compliance Coordinator(s) determines that Early Complaint Resolution is appropriate, the Compliance Coordinator will facilitate settlement discussions between the parties and work with the parties to help them understand the legal standards and possible remedies. The Compliance Coordinator(s) will attempt to resolve the complaint within 5 school days. Any time during Early Complaint Resolution, either party can opt to move to Level II. Throughout the process, building administrator(s) will be kept apprised of developments.

Early Complaint Resolution is not appropriate in cases of sexual violence, if multiple complaints have been lodged against the same alleged discriminator, or if either party opts out of Level I in lieu of moving to Level II.

Students

Nondiscrimination (Cont'd)

Level II: Formal Complaint

The complainant shall, within 180 days of the alleged incident, on forms provided, put the complaint in writing and file it with the Compliance Coordinator(s). The Complainant may file the complaint orally and the Coordinator will reduce it to writing. The following are the steps involved in investigating a complaint:

- 1) The Coordinator will interview the complainant and, if different, the student victim within two school days following receipt of the complaint.
- 2) If applicable, steps will be taken to protect the complainant/victim, including developing an interim safety plan, pending the final outcome of the investigation.
- 3) After gathering information from the complainant/victim, the Coordinator will inform the accused of the charges and interview the accused within two school days following receipt of the complaint.
- 4) The Coordinator will investigate and resolve the complaint within five school days if possible, but within no more than ten school days following receipt of the complaint.
- 5) During the investigation, the Coordinator is a neutral fact-finder. Techniques used during the investigation will include reviewing documentary evidence and conducting witness interviews.
- 6) The Coordinator will use the preponderance of the evidence standard to determine whether discrimination occurred.
- 7) The Coordinator will document all efforts to gather evidence and summarize the underlying evidence in an investigative report, which will include a description of relevant facts and analysis under the appropriate legal standard(s) as well as a description of the actions to remedy harm to the victim and school community, if any.
- 8) At the end of the investigation, parties will be notified of the outcome of the complaint subject to the District's legal responsibilities to comply with the Family Educational Rights and Privacy Act (FERPA) 20 U.S.C. § 1232g. If it is found that discrimination occurred steps will be taken to end the discrimination, prevent its reoccurrence and remedy its effects on those impacted.
- 9) In the case of harassment, appropriate steps to end discriminatory harassment will be taken. This may include separating the victim and harasser, providing counseling for the victim and/or harasser, and/or taking disciplinary action against the harasser. Strategies to eliminate any hostile environment will be identified and implemented. These steps should not penalize the victim. If needed, a final safety plan will be implemented for the victim.

Students

Nondiscrimination (Cont'd)

Level III: Appeal

Within ten school days of receiving the Coordinator's decision, either party may appeal the findings to the Superintendent. In the appeal, the party must explain why he or she believes the factual information was incomplete, the analysis of the facts was incorrect, and/or the appropriate legal standard was not applied and how this would change the District's determination in the case. The Superintendent, upon receiving a written appeal, will have ten school days to resolve the appeal of the complaint.

Draft

***Granby Public Schools
Discrimination Grievance Form***

Any student, parent/guardian, employee or employment applicant who feels that he/she has been discriminated against or witnessed the discrimination of another student, parent/guardian, employee, or employment applicant on the basis of **race, color, religious creed, sex, age, national origin, ancestry, marital status, sexual orientation, gender identity or expression, disability, or genetic information** may discuss and/or file a grievance with the assistance of one of the individuals listed below.

For a Student or Employee who believes that he or she has been discriminated against:

TO BE COMPLETED BY COMPLAINANT AND/OR COMPLIANCE COORDINATOR

Name of Complainant _____

STUDENT ____ PARENT/GUARDIAN ____ EMPLOYEE ____ APPLICANT ____

HOME ADDRESS _____

PHONE _____ DATE OF CLAIM _____ DATE OF ALLEGED INCIDENT _____

Statement of Incident: *Describe the incident(s) as clearly as possible. Include when and where the incident(s) occurred, and list any witnesses present.*

This complaint is filed based on my honest belief that _____ (person who discriminated) has unlawfully discriminated against another. I hereby certify that the information I have provided in this complaint is true, correct and complete to the best of my knowledge.

Complainant Signature _____ Date _____

Please attach any additional information/documentation necessary.

SIGNATURE OF COMPLAINANT _____

SIGNATURE OF COMPLIANCE COORDINATOR _____

DATE RECEIVED _____

TO BE COMPLETED BY COMPLIANCE COORDINATOR

LEVEL I: Early Complaint Resolution [*Informal Resolution Mechanism*]

Early Complaint Resolution allows the parties (the complainant and the individual who caused the alleged discrimination) an opportunity to resolve the alleged discrimination quickly. If both parties are willing to try this approach, **and** if the Compliance Coordinator(s) determines that Early Complaint Resolution is appropriate, the Compliance Coordinator will facilitate settlement discussions between the parties and work with the parties to help them understand the legal standards and possible remedies. The Compliance Coordinator(s) will attempt to resolve the complaint within 5 school days. Any time during Early Complaint Resolution, either party can opt to move to Level II. Throughout the process, building administrator(s) will be kept apprised of developments.

Early Complaint Resolution is not appropriate in cases of sexual violence, if multiple complaints have been lodged against the same alleged discriminator, or if either party opts out of Level I in lieu of moving to Level II.

1. Name of person Filing this Complaint: _____

Address: _____

City: _____ State: _____ Zip Code: _____

Home Telephone: _____ Work Telephone: _____

E-mail Address: _____

2. Name of Person Discriminated Against (if other than person filing): _____

Address: _____

City: _____ State: _____ Zip Code: _____

Home Telephone: _____ Work Telephone: _____

E-mail Address: _____

3. Granby Public Schools enforces prohibiting discrimination on the basis of race, creed, color, religion, gender, gender identification or expression, national origin, age, disability, marital status, pregnancy, genetic information, or retaliation. Please indicate the basis of the complaint.

Discrimination **based on race (specify):** _____

Discrimination **based on color (specify):** _____

Discrimination **based on religion (specify):** _____

LEVEL II *The complainant shall, within 180 days of the alleged incident, on forms provided, put the complaint in writing and file it with the Compliance Coordinator(s). The Complainant may file the complaint orally and the Coordinator will reduce it to writing.*

- 1) The Coordinator will interview the complainant and, if different, the student victim within two school days following receipt of the complaint.
- 2) If applicable, steps will be taken to protect the complainant/victim, including developing an interim safety plan, pending the final outcome of the investigation.
- 3) After gathering information from the complainant/victim, the Coordinator will inform the accused of the charges and interview the accused within two school days following receipt of the complaint.
- 4) The Coordinator will investigate and resolve the complaint within five school days if possible, but within no more than ten school days following receipt of the complaint.
- 5) During the investigation, the Coordinator is a neutral fact-finder. Techniques used during the investigation will include reviewing documentary evidence and conducting witness interviews.
- 6) The Coordinator will use the preponderance of the evidence standard to determine whether discrimination occurred.
- 7) The Coordinator will document all efforts to gather evidence and summarize the underlying evidence in an investigative report, which will include a description of relevant facts and analysis under the appropriate legal standard(s) as well as a description of actions to remedy harm to the victim and school community, if any.
- 8) At the end of the investigation, parties will be notified of the outcome of the complaint. If it is found that discrimination occurred steps will be taken to end the discrimination, prevent its recurrence and remedy its effects on those impacted. In instances where it has been determined that harassment occurred [this is essentially the same thing], action will be taken to stop any harassment, prevent its recurrence, and remedy its effects on those impacted.
- 9) In the case of harassment, appropriate steps to end discriminatory harassment will be taken. This may include separating the victim and harasser, providing counseling for the victim and/or harasser, and/or taking disciplinary action against the harasser. Strategies to eliminate any hostile environment will be identified and implemented. These steps should not penalize the victim. If needed, a final safety plan will be implemented for the victim.
- 10) Within ten school days of receiving the Coordinator's decision, either party may appeal the findings to the Superintendent. In the appeal, the party must explain why he or she believes the factual information was incomplete, the analysis of the facts was incorrect, and/or the appropriate legal standard was not applied and how this would change the District's determination in the case.
- 11) The Superintendent, upon receiving a written appeal, will have ten school days to resolve the appeal of the complaint.

Action Taken:

_____ **The investigator believes the complainant is *satisfied* with the action taken.**

_____ **Resolution was *unsatisfactory* and a Level III complaint was filed with the Superintendent.**

Signature of Compliance Coordinator

Date

LEVEL III Within ten school days of receiving the Coordinator's decision, either party may appeal the findings to the Superintendent. In the appeal, the party must explain why he or she believes the factual information was incomplete, the analysis of the facts was incorrect, and/or the appropriate legal standard was not applied and how this would change the District's determination in the case. The Superintendent, upon receiving a written appeal, will have ten school days to resolve the appeal of the complaint.

ACTION TAKEN:

_____ **The investigator believes the complainant is *satisfied* with the action taken.**

_____ **Resolution was *unsatisfactory* and a level IV complaint was filed with the Board of Education.**

Signature of Superintendent

Date

LEVEL IV *The Board of Education, Superintendent and the Compliance Coordinator(s) shall proceed in accordance with appropriate state statutes.*

ACTION TAKEN

_____ **The investigator(s) believe the complainant is *satisfied* with the action taken.**

_____ **Resolution was *unsatisfactory* and a Level V complaint was filed with**
_____.

Signature of BOE Designee

Date

LEVEL V *If the complainant wishes to pursue the grievance, he/she shall proceed in accordance with appropriate state statutes. Contact information is as follows:*

Boston Office of Civil Rights
US Department of Education, 8th Floor
5 Post Office Square
Boston, MA 02109
617-289-01111
OCR.Boston@ed.gov
www.ed.gov/about/offices/list/ocr/know.html

State Title IX Compliance
Dr. William A. Howe
Bureau of Accountability and Improvement
165 Capitol Avenue, Room 227
Hartford, CT 06106
860-713-6752
william.howe@ct.gov

The Commission on Human Rights and Opportunities (CHRO)
25 Sigourney Street
Hartford, CT 06106
860-541-3400
www.state.ct.us/chro/

Right to File a Separate Court Action

The complainant may have the right to file suit in Federal court, regardless of the school districts findings. Granby Public Schools does not represent the complainant in case processing, so if the complainant wishes to file a court action, he or she must do so through his or her own attorney or on his or her own through the court's pro se clerk's office. If a complainant alleges discrimination prohibited by the Age Discrimination Act of 1975, a civil action in Federal court can be filed only after the complainant has exhausted administrative remedies. Administrative remedies are exhausted when either of the following has occurred: 1) 180 days have elapsed since the complainant filed the complaint with Granby Public Schools and Granby Public Schools has made no finding; or 2) Granby Public Schools issues a finding in favor of the recipient. If this occurs, Granby Public Schools will promptly notify the complainant and will provide additional information about the right to file for injunctive relief.

Additional information may also be obtained by contacting:

Boston Office of Civil Rights
US Department of Education, 8th Floor
5 Post Office Square
Boston, MA 02109
617-289-01111
OCR.Boston@ed.gov
www.ed.gov/about/offices/list/ocr/know.html

State Title IX Compliance
Dr. William A. Howe
Bureau of Accountability and Improvement
165 Capitol Avenue, Room 227
Hartford, CT 06106
860-713-6752
william.howe@ct.gov

The Commission on Human Rights and Opportunities (CHRO)
25 Sigourney Street
Hartford, CT 06106
860-541-3400
www.state.ct.us/chro/

Draft

Granby Public Schools

Granby, CT

To: Board of Education
From: Alan Addley, Superintendent of Schools
Date: January 2, 2013
Re: FY14 Plus One Budget Submission

Each year, the Board of Education develops and then submits budget projections to the Board of Finance for use in the budget guideline process. The first year of operating budget projections is typically the most accurate. Longer-range projections are based on enrollment projections and broad assumptions which can vary widely over time. These projections, along with small capital and large capital needs, are forwarded to the Capital Program Priorities Advisory Committee (CPPAC) for use in long-range planning.

The CPPAC Submission has three parts: Plus One/Operating Budget Projections (five years), Small Capital Projections (ten years), and Large Capital Projections (ten years). Upon adoption by the Granby Board of Education, this document is forwarded to the Board of Finance and Capital Program Project Advisory Committee for use in establishing budget guidelines and long-range planning.

The Plus One budget for the next five years support the Board FY14 Budget Goals which include the Common Core State Standards, Teacher/ Administrator Evaluation, Secondary School Reform, elementary languages; and the intervention recommendations of the special education review. The Plus One Budget is responsive to declining enrollment and a slow recovering economy. In the last three years, and in response to dropping enrollment, operating budgets have had an average increase less than 1%.

Board Approved FY14 Budget Goals

To develop a budget that:

1. Supports the vision, mission, values, and goals of the district;
2. Recognizes the economic climate, realizes efficiencies and is responsive to the financial guidelines set by the Board of Finance;
3. Provides levels of personnel, programs, infrastructure, and services that meet the essential needs of the district;
4. Addresses High School Reform, Common Core Standards and Teacher/Administrator Evaluation; and,
5. Supports Board studies (World Languages, 1-to-1 computing; intermediate schools, interventions for students & PLC time).

Assumptions

- BOF 2% guideline expected from the Board of Finance.
- Inflation: 2.2% CPI. Level-funded line items/consumables. Prior 12 months educational books and supplies CPI = 6.9%.
- Retirements: 7 certified employees – salary savings of approximately \$140,000 partially offset by retiree health premium payments for the first two years.
- Health Benefits: A 7.5% rate cost change vs. FY13 actual rate less favorable census changes and premium share increases nets to a 4.5% change.
- Transportation: Replacement of one (1) 2002 seventy-seven (77) passenger bus.
- Salaries: Negotiated salaries adjusted for anticipated retirements; 2.5% Admin; 2.5% Teachers & 3% for remaining employees.
- Utilities: Oil @ \$3.29 per gallon.
Electricity @ 15.2 cents/kwH.
- Enrollment: FY14 K-12 enrollment (2,026) reflects a decline by 61 students from FY13 actual (2,087).

Enrollment

District enrollment is projected to decrease steadily over the next five to ten years. K-12 district enrollment (2,026) will decline by 61 students from actual (2,087). Primarily for FY14 declines in enrollment will occur at the high school and intermediate schools. For FY14, class sizes in most grades will be comparable to DRG and state averages.

	Actual	Projected			
	2012-2013	2013-2014	2014-2015	2015-2016	2016-2017
PK	16	20	20	20	20
K-2	366	373	362	331	300
3-6	630	588	553	527	510
7-8	330	327	322	309	295
9-12	761	738	704	714	688
Total K-12	2,087	2,026	1,941	1,881	1,793

FY14 Small Cap Budget Summary

	Small Cap Total	FY14 Spending	Existing Lease Commitments
FF&E	\$ 24,500	\$ 24,500	
Maintenance	\$106,220	\$106,220	
Technology*	\$243,864	\$ 31,932	\$211,932
Transportation*	<u>\$225,416</u>	<u>\$ 9,239</u>	<u>\$216,177</u>
Totals	\$600,000	\$171,891	\$428,109

*Technology expenses above of \$243,864, will support existing leases and FY14 purchases of \$276,494 and Transportation expenses of \$225,416 will support existing leases and FY14 purchases of \$80,000.

Operating Budget Projections

	<u>FY12</u>	<u>FY13</u> [♦]	<u>FY14</u>	<u>FY15</u>	<u>FY16</u>	<u>FY17</u>	<u>FY18</u>
Operating Sub-Total	\$26,983,001	\$27,297,831	\$27,879,902	\$28,742,547	\$29,723,675	\$30,786,891	\$31,922,875
% Increase	0%	1.2%	2.1%	3.1%	3.4%	3.6%	3.7%

♦ Base adjusted \$100K per agreement with BOF.

Quality & Diversity (Q&D) Budget Projections

Funds received from the Open Choice Program are deposited into a town revolving account (Q&D) established by the Board of Finance. Expenditures are used to fund magnet school tuitions and transportation, partial funding for full-day kindergarten, academic and social support for Open Choice students, and enrichment activities for all Granby students.

	<u>FY12</u>	<u>FY13</u>	<u>FY14</u>	<u>FY15</u>	<u>FY16</u>	<u>FY17</u>	<u>FY18</u>
Expenditures	\$353,598	\$690,930	\$650,000	\$660,000	\$670,000	\$680,000	\$690,000

2013-2014 School Year

Personnel

7.0 FTE Staff

7.0 FTEs are included in the FY14 Plus One Budget. These positions will be supported through the operating budget, personnel attrition, declining enrollment, redeployment and the implementation of the recommendations from the special education review.

1. Elementary Spanish Teacher: Expansion of the world language program into grades 3-4 will require the addition of a full-time teacher (1.0 FTE).
2. Math/Science Instructional Coach: This position is similar to the current consulting teacher positions and will work directly with teachers to improve instructional practices with a particular focus on math and sciences for grades 7-12. Consulting coaches will also provide teacher support in the CCSS and will assist with Tier III interventions (1.0 FTE).
3. Instructional Coach (K-12): This position will be similar to consulting teacher positions. The coach will work directly with teachers to improve instructional practices with a particular focus on Tier III interventions and assisting teachers to meet the needs of our highest performing students in the classroom setting (1.0 FTE).
4. High School Science Teacher: Science classes continue to be oversubscribed. This part-time position provides additional science electives for students and helps address the increased credit requirements of the pending high school reform (0.4 FTE).
5. Math (Interventionist): This part-time position provides Tier I, II & III math interventions at the high school and supports the recommendations for the special education review (0.6 FTE).
6. Special Education Resource Teachers: Provision of literacy interventions in each of the elementary schools – supports the recommendations for the special education review (3.0 FTE).

Other:

7. Teacher/Administrator Evaluation: The new plan will require ongoing professional development for teachers and administrators (\$21,500), a new data management system (\$35,000); and an increase in contracted hours for data management (\$15,000).
8. Common Core State Standards (CCSS): The CCSS will require additional curriculum writing in all curriculum areas (\$10,000).
9. Director of Guidance Stipend (\$3,162): An increase in the stipend for Director of Guidance to attract qualified candidates to provide departmental leadership for grades 6-12.
10. New Texts: The new text line item supports Integrated Chinese, English 9 (The Glass Castle), English 9 (The Book Thief) (\$7,811).
11. FVVNA contract for nurses: This is the last year of the current two-year agreement. The new two-year contract reflects a 4% increase over 2 years (\$12,310).
12. Transportation: One large bus is included in the small capital request. The bus will replace a 2002 seventy-seven (77) passenger bus (\$80,000).

13. Technology: Includes \$60,000 (small capital) to expand and complete wireless access at the two intermediate schools; \$27,300 (small capital) of minimum spending to support a 1-to-1 platform and a software increase of \$76,350 (operating budget) that supports the teacher/administrator data systems and on-line interventions for reading and math.
14. Special Education: Tuition expenses are projected to be \$870,021 (\$202,047 increase) and transportation \$343,594 (\$131,389 decrease). Some of these dollars will be offset by the state excess special education grant funds; the gross amount increases our FY14 expenditures by \$70,658. Special education salaries will have a net reduction of \$159K due to realized efficiencies from the special education review.
15. Health Costs: A 7.5% rate cost change vs. FY14 budget rate less favorable census changes and premium share increases net to a 4.5% change. Gross health and dental insurance costs is estimated to be approximately \$4,250,544. The amount on the statement of accounts is shown net of approximately \$1,240,126 employee contributions.
16. A special education IDEA grant shortfall is transferred to the operating budget to support salaries of certified support staff (\$28,000).
17. New Security Measures: Anticipated upgrades to security (\$10,000).
18. Athletics & Extracurricular Activities: Assistant Indoor Track Coach (\$3,404); Stock Market Club (\$828); Fitness Club (\$828); and, five (5) Title IX Coordinators (\$4,140).
19. For several consecutive years some of the consumables in line items have remained level funded. Various consumables have been zero-based budgeted.
20. The reduction of funds for new equipment and repairs and the dependency on the small capital budget are not fully meeting the ongoing maintenance needs of the district, particularly for replacement desks and painting. It is anticipated that we will need an additional \$25,000 in FY13 year-end spending to keep pace with the painting needs across the district.

2014-2015 School Year

Personnel

2.2 FTE Staff

1. Elementary Spanish Teacher: A new teaching position would expand the program into grades K-2 (1.0 FTE).
2. Special Education Teacher: An additional special education resource teacher at Kearns to support the recommendations from the special education review (1.0 FTE).
3. Mandarin Chinese IV: Expansion of the Chinese language program to Level IV would require an additional 0.2 FTE teaching position (0.2 FTE).

Other

4. Technology: K-12 Media Center Automation Circulation System (\$26,000).
5. New Courses: Capstone Class (\$1,000); AP Physics (\$3,350); Sports & Entertainment Marketing (\$2,500); and, Intro to Engineering (\$1,700).
6. New texts: Chemistry (\$13,200) and Conceptual Physics (\$2,500).

2015-2016 School Year

Personnel

0.2 FTE Staff

1. 0.2 FTE Chinese Teacher Middle School (\$71,619)

2016-2017 School Year

Personnel

1.0 FTE Staff

1. Music Teacher (strings) (\$71,619). This position provides a placeholder for the expansion of the arts curriculum. A curriculum audit would be conducted in the preceding years to assess the actual programmatic needs of the district (1.0 FTE).

2017-2018 School Year

1.0 FTE Staff

Personnel

1. Music Teacher (strings) (\$71,619). This position provides for the continued expansion of the arts curriculum (1.0 FTE).

Funded FY14 Small Cap

Furniture, Fixtures & Equipment (FF&E) \$24,500

- Science Lab Tables (HS \$4,000)
- Classroom Chairs (MS \$3,500)
- Tables (KL/WR \$2,000)
- Classroom Furniture (5 Classrooms) (KR \$15,000)

Maintenance \$106,220

- Replace Heating Coil in Media Center (KR \$5,500)
- Replace Expansion Tank on Boilers (KR \$8,000)
- Install VCT (9 Classrooms) (KR \$22,000)
- Repair Bleachers (HS \$18,075)
- Replace Risers (MS \$19,000)
- Major Roof Repair (District \$15,000)
- Install Sink Room 3108 (HS \$3,500)
- Kaivac 12 Gal. Restroom Cleaner (District \$8,010)
- Floor Buffers (District \$2,250)
- Wet Vacuum (District \$1,080)
- Emergency Funds (District \$3,805)

Technology \$276,494

Purchases (\$123,415)

- Contingency for BYOD Devices Grades 7-12 (MS/HS \$27,300)
- Wireless Access Points for Intermediate Schools (WR/KL \$60,000)
- Kearns School Data Wiring (\$16,000)
- Laptops for Room 3 (WR \$4,500)
- Media Center (iPads, Kindles, Headphones, Whiteboard) (KR \$5,615)
- Resource Room iPads (District \$10,000)

Replacement (\$131,079)

- Servers (5 for District \$23,171)
- Switches (KR/KL/WR/BOE \$21,689)
- Laptops (HS/BOE \$6,120)
- Computers for Business/CAD Labs (HS \$36,400)
- Interactive Whiteboards (HS/MS/KL/WR/KR \$39,000)
- Printers (BOE/HS/MS/KL/WR/KR \$4,699)

Emergency Repair and Equipment (\$22,000)

- Repair for Cameras and Digital Equipment (\$10,000)
- Emergency Computer Repairs (\$12,000)

Transportation \$80,000

Buses (\$80,000)

- Purchase of one new 77 passenger bus

Unfunded FY14 Items

Personnel **\$23,505**

- 0.2 FTE Music (MS \$14,323)
- Increased Secretarial Hours for full-year secretary @ Kelly (\$9,182)

Stipend Positions **\$11,852**

- MS Stipend for Cross Country (\$1,902)
- Fall Cheerleading (\$3,250)
- After-School Supervisor (\$5,250)
- Volleyball Club (\$1,450)

Programs et al **\$40,400**

- American Studies (HS \$1,200)
- K-12 Media Center Automation Circulation System (District \$26,000)
- Chemistry Texts (HS \$13,200)

Small Capital

Furniture, Fixtures & Equipment (FF&E) **\$127,842**

- Portable Fencing for Athletic Fields (HS \$7,000)
- Chairs/Tables for English Classroom (HS \$3,180 One Classroom)
- Chairs/Tables for English Classrooms (HS \$47,040 7 Classrooms)
- Three (3) Four-Station Work Benches w/lockers (HS \$5,100)
- Student Desks (HS \$5,000)
- Tables for Reading Room (HS \$1,000)
- Tools (HS \$1,000)
- De-ionizer and cartridges for distiller (HS Science \$1,300)
- Thermal Cycler (HS Science \$3,500)
- Updated ovens in Room 1215 (HS \$10,000)
- Overhead Fan in Room 1215 (HS \$2,000)
- Kiln/Cone 10, Digital Kiln Sitter and Environmental Hood (HS Art \$5,325)
- Drop down divider for main gym (HS \$15,000)
- Paved area in front of production lab windows (HS \$5,000)
- 6'x7' garage door and installation (HS \$4,000)
- Yamaha Baritone Saxophone (HS \$4,628)
- Wenger, 3 column band folio storage cabinet (HS \$1,269)
- Bleachers (MS \$4,000)
- Student Desks (KL \$1,250)
- Classroom Chairs/Stools (KL \$1,250)

Unfunded FY14 Items (Cont'd)

Maintenance

\$359,314

- Roof Repairs/Maintenance (HS \$10,000)
- Paint Classrooms/Hallway (HS \$15,000)
- Paint Classrooms/Hallway (MS \$11,000)
- Paint Gym (MS \$8,000)
- Paint Classrooms/Hallways/Outside Panels (WR \$13,500)
- Paint 10 Classrooms/Hallway/Backstop (KL \$15,000)
- Repave Entrance off Route 189 (HS \$36,000)
- Gym Floor Tarps (MS \$1,500)
- Bleachers (MS \$8,414)
- Replace Teacher Entrance Door (MS \$10,000)
- Replace two Exterior Doors by Loading Dock (MS \$10,000)
- Replace Door at the end of the Tech Wing Hall (MS \$7,000)
- Replace Door Hardware (MS \$3,000)
- Replace Bathroom Partitions/Doors (2 bathrooms) (MS \$15,000)
- Tree Pruning (KL \$8,000)
- Auto Flush Valves (KL \$3,000)
- Repair Roofline (where gutters were removed in courtyard) (WR \$20,000)
- Door Magnets (Gym/Café) (WR \$2,000)
- Repair Media Center Doors Hardware (WR \$5,000)
- Install Dividers in Boys' Bathroom (KR \$2,000)
- Lawn Mower (KR \$5,500)
- Replace Entrance Doors in Front (KR \$15,000)
- A/C Repairs Rooms 36 & 38 (KR \$5,000)
- Replace Window Blinds (KR \$2,500)
- Replace Classroom Sinks/Cabinets/Counters (KR \$20,000)
- Vacuums (14" & 16") (District \$6,100)
- Puma Air Mover (District \$1,400)
- Replace Mower Deck on Ferris 72" Mower (District \$6,000)
- Carpet Extractor (District \$3,400)
- Catch Basin Repairs (District \$12,000)
- Replace Sinks and Counter Tops in Bathroom (1 bathroom) (MS \$13,000)
- Replace Lockers (MS \$62,000)
- Landscaping (MS \$4,000)

Technology

\$239,462

- Science – laptop lab (HS \$28,000)
- RM 61 – convert to lab or mobile lab (MS \$28,000)
- Media Center - wiring for additional computers (HS \$3,000)
- Office – 2 iPads (HS \$1,400)
- PE – mounted screen and projector (HS \$7,912)
- English – eReaders (HS \$4,500)
- Office – 2 color printers principals (HS \$1,000)
- World Language – printer (HS \$350)
- School – bell system (HS \$20,000)
- School – phone system (HS \$140,000)
- English – printers (HS \$1,000)
- Tech Ed – 5 additional camcorders (MS \$1,800)
- Tech Ed – 70" LCD TV (MS \$2,500)

GRANBY PUBLIC SCHOOLS
10 YEAR SMALL CAPITAL BUDGET ESTIMATE

FISCAL YEAR	2014	2015	2016	2017	2018	2019	2020	2021	2022	2023
BLDG. MAINTENANCE & EQUIPMENT	106,220	603,688	326,230	448,775	263,500	156,300	123,400	324,800	109,800	100,900
FURNITURE & FIXTURES	24,500	156,585	56,896	48,500	24,150	17,750	27,750	17,450	17,550	25,550
TECHNOLOGY LEASE	243,863	262,162	297,392	331,179	350,326	369,161	384,660	387,709	395,603	367,100
BUSES/TRANSPORTATION LEASE	225,416	215,339	205,745	221,080	224,051	222,890	239,284	246,276	241,104	219,260
TOTAL ALL ABOVE	600,000	1,237,774	886,263	1,049,534	862,027	766,091	775,093	976,234	764,158	712,810
BOF TARGETS	525,000	600,000	600,000	600,000	600,000	600,000	600,000	600,000	600,000	600,000
+RENTAL REVENUE	75,000	15,000	15,000	15,000	15,000	15,000	15,000	15,000	15,000	15,000
BUDGETED FUNDING TARGET	600,000	615,000	615,000	615,000	615,000	615,000	615,000	615,000	615,000	615,000
Over/(Under) BOF Target	(0)	622,774	271,263	434,534	247,027	151,091	160,093	361,234	149,158	97,810
MAINTENANCE BY SITE:										
DISTRICT										
HS	30,145	46,944	24,900	50,400	10,600	13,400	18,000	9,400	8,400	14,500
MS	21,575	204,144	127,230	214,275	82,000	58,000	15,000	62,000	24,000	15,000
KEARNS	19,000	137,500	88,000	105,000	60,000	15,000	18,000	216,000	46,000	36,000
KELLY LANE	35,500	96,000	52,500	40,000	33,500	21,000	25,000	17,000	11,000	11,000
WELLS RD.	0	66,000	17,000	22,500	40,000	19,500	14,000	5,000	5,000	9,000
CENTRAL OFFICE	0	51,900	15,400	15,400	37,400	29,400	33,400	15,400	15,400	15,400
TOTALS ABOVE	106,220	603,688	326,230	448,775	263,500	156,300	123,400	324,800	109,800	100,900
FURNITURE & FIXTURES BY SITE										
DISTRICT										
HS	4,000	123,935	37,246	32,300	6,800	8,300	12,900	6,500	4,500	10,500
MS	3,500	17,400	6,900	6,700	4,200	4,700	5,200	3,700	5,900	9,900
KEARNS	15,000	6,500	5,500	4,500	10,000	2,500	3,000	2,000	2,500	1,000
KELLY LANE	1,000	2,750	5,250	3,000	1,650	1,250	4,150	3,250	2,250	1,650
WELLS RD.	1,000	2,500	2,000	2,000	1,500	1,000	2,500	2,000	2,500	2,500
CENTRAL OFFICE/SPED	0	3,500	0	0	0	0	0	0	0	0
TOTALS ABOVE	24,500	156,585	56,896	48,500	24,150	17,750	27,750	17,450	17,650	25,550
TECHNOLOGY PURCHASES	276,494	318,550	355,047	276,594	320,213	379,246	350,000	350,000	350,000	350,000
BUS PURCHASES	80,000	61,753	254,616	262,254	270,122	92,742	191,048	196,780	286,232	104,382

GRANBY PUBLIC SCHOOLS OPERATING BUDGET PROJECTIONS FY14-FY19

Description	FY2011A Actual	FY12 Actual	FY13 Budget	FY2014 Plus One	FY14\$: FY13%	FY2015 Projection	FY2016 Projection	FY2017 Projection	FY2018 Projection	FY2019 Projection	FY14: FY15	FY15: FY16	FY16: FY17	FY17: FY18	FY18: FY19
Certified Salaries:															
Administration	1,488,904	1,573,862	1,581,064	1,619,935	38,871 2.5%	1,660,433	1,701,944	1,744,493	1,788,105	1,832,808	2.5%	2.5%	2.5%	2.5%	2.5%
Regular Education	9,428,328	9,785,808	9,929,178	10,216,407	287,229 2.9%	10,515,457	10,729,743	10,996,387	11,302,666	11,589,161	2.9%	2.0%	2.5%	2.8%	2.3%
Sp. Education Certified Salaries	1,255,537	1,285,028	1,307,895	1,175,321	-132,574 -10.1%	1,204,704	1,234,822	1,265,683	1,301,132	1,337,564	2.5%	2.5%	2.5%	2.8%	2.8%
Total Certified Salaries	12,154,669	12,644,698	12,818,137	13,011,663	193,528 1.5%	13,380,595	13,666,509	14,006,572	14,391,923	14,729,532	2.8%	2.1%	2.5%	2.8%	2.3%
Substitute/Tutor/Support Salaries															
Substitutes	145,310	152,000	152,000	160,000	8,000 5.3%	163,200	166,464	169,793	173,224	177,224	2.0%	2.0%	2.0%	2.0%	2.0%
Sped Support - P.T./O.T.	262,024	262,988	291,004	289,682	6,978 3.0%	307,174	314,853	320,725	330,793	339,063	2.5%	2.5%	2.5%	2.5%	2.5%
Tech Support	173,277	180,981	180,981	186,163	5,182 2.9%	190,817	196,587	202,477	205,489	210,626	2.6%	2.6%	2.5%	2.5%	2.5%
Tutors - Regular Education	148,894	157,411	187,411	119,148	-38,263 -24.3%	122,127	125,180	128,309	131,517	134,805	2.5%	2.5%	2.5%	2.5%	2.5%
Tutors - Special Education	169,112	190,233	85,579	102,463	16,874 19.7%	105,014	107,640	110,331	113,089	115,816	2.5%	2.5%	2.5%	2.5%	2.5%
Total Tutors & Subs	898,617	943,613	866,975	867,446	471 0.1%	888,332	908,724	931,635	960,715	979,634	2.4%	2.4%	2.4%	2.0%	2.4%
Teaching Assistant Salaries:															
Reg. Ed. Teaching Assistants	459,784	456,601	427,307	442,407	15,100 3.5%	453,467	464,804	478,748	493,110	507,804	2.5%	2.5%	3.0%	3.0%	3.0%
Sp. Ed. Teaching Assistants	877,403	910,337	828,487	786,952	-31,535 -3.8%	816,876	837,298	862,417	888,289	914,838	2.5%	2.5%	3.0%	3.0%	3.0%
Total	1,337,187	1,366,938	1,255,794	1,229,359	-16,435 -1.3%	1,270,343	1,302,102	1,341,165	1,381,400	1,422,642	2.5%	2.5%	3.0%	3.0%	3.0%
School Secretaries' Salaries	532,063	556,263	533,350	524,444	-9,906 -1.7%	537,555	550,894	564,769	578,888	593,360	2.5%	2.5%	2.5%	2.5%	2.5%
Central Office Salaries	350,863	347,764	400,889	408,795	7,896 2.0%	419,015	429,490	440,228	451,233	462,514	2.5%	2.5%	2.5%	2.5%	2.5%
Custodial & Maintenance Salaries	1,227,240	1,253,595	1,245,050	1,266,451	21,361 1.7%	1,297,712	1,330,155	1,363,409	1,397,484	1,432,432	2.5%	2.5%	2.5%	2.5%	2.5%
Purchased Services:															
Purchased Services Instructional	204,238	212,952	318,560	344,060	25,500 8.0%	324,402	330,890	337,508	344,258	351,144	0.0%	2.0%	2.0%	2.0%	2.0%
Administration	622,975	404,049	414,462	428,822	12,360 3.0%	426,822	435,358	444,066	452,947	462,006	0.0%	2.0%	2.0%	2.0%	2.0%
Maintenance	89,389	86,115	88,260	88,260	0 0.0%	90,467	93,180	95,976	98,855	101,821	2.5%	3.0%	3.0%	3.0%	3.0%
Total Purchased Services	916,602	703,116	821,302	859,162	37,860 4.6%	841,691	859,429	877,560	896,061	914,970	-2.0%	2.1%	2.1%	2.1%	2.1%
Legal Services	30,124	65,000	65,000	65,000	0 0.0%	65,000	65,000	65,000	65,000	65,000	0.0%	0.0%	0.0%	0.0%	0.0%
Repairs & Maintenance:															
Instructional	77,787	87,050	87,050	77,050	-10,000 -11.5%	78,561	80,163	81,766	83,401	85,069	2.0%	2.0%	2.0%	2.0%	2.0%
Administration	35	8,500	8,500	8,500	0 0.0%	8,500	8,500	8,670	8,843	9,020	0.0%	0.0%	2.0%	2.0%	2.0%
Maintenance	478,022	245,710	270,710	295,710	25,000 9.2%	307,533	319,840	332,634	348,265	366,728	4.0%	4.0%	4.0%	5.0%	5.0%
Total Repairs & Maintenance	555,844	341,260	366,260	381,260	15,000 4.1%	394,629	408,503	423,070	441,510	460,818	3.5%	3.5%	3.5%	4.4%	4.4%
Transportation:															
Regular Education	742,772	783,341	785,473	780,486	-4,977 -0.6%	803,911	828,028	852,869	878,455	904,808	3.0%	3.0%	3.0%	3.0%	3.0%
Special Education Transportation	415,528	383,198	474,983	343,594	-131,389 -27.7%	357,338	371,631	385,497	401,966	418,035	4.0%	4.0%	4.0%	4.0%	4.0%
Vocational-Tech	40,206	48,125	44,514	44,514	0 0.0%	45,952	47,331	48,751	50,213	51,720	3.0%	3.0%	3.0%	3.0%	3.0%
Total	1,198,506	1,214,563	1,305,070	1,168,704	-136,366 -10.4%	1,207,201	1,246,990	1,288,115	1,330,625	1,374,563	3.3%	3.3%	3.3%	3.3%	3.3%
Insurance - Property & Liability	70,421	71,508	74,008	74,008	0 0.0%	76,488	76,988	79,308	81,687	84,138	2.0%	2.0%	2.0%	3.0%	3.0%
Communications	84,168	90,107	92,267	92,267	0 0.0%	94,112	95,995	98,874	101,841	104,896	2.0%	2.0%	3.0%	3.0%	3.0%
Tuition:															

GRANBY PUBLIC SCHOOLS OPERATING BUDGET PROJECTIONS FY14-FY19

Description	FY2014A	FY12	FY13	FY2014	FY14S	FY2015	FY2016	FY2017	FY2018	FY2019	FY16:	FY17:	FY18:	FY19:
	Actual	Actual	Budget	Plus One	FY13\$	FY13%	Projection	Projection	Projection	Projection	FY14	FY15	FY16	FY19
Vocational	55,944	63,936	71,928	79,920	7,992	11.1%	55,944	71,928	71,928	71,928	-30.0%	14.3%	12.5%	0.0%
Special Education Tuition	632,500	729,728	667,974	870,021	202,047	30.2%	913,522	1,007,168	1,057,516	1,110,392	5.0%	5.0%	5.0%	5.0%
Adult Education	8,304	9,000	9,000	9,000	0	0.0%	9,270	9,835	10,130	10,433	3.0%	3.0%	3.0%	3.0%
Total	596,748	802,664	748,902	950,941	210,039	28.0%	978,736	1,088,921	1,139,574	1,192,763	2.1%	5.5%	6.4%	4.7%
Conference & Travel	36,359	56,425	54,922	57,922	3,000	5.5%	59,370	62,833	64,718	66,659	2.5%	2.8%	3.0%	3.0%
General Supplies:														
Regular Education	296,240	287,180	275,280	275,280	0	0.0%	282,162	288,921	307,578	316,805	2.5%	2.8%	3.0%	3.0%
Special Education	17,897	26,300	26,300	26,300	0	0.0%	26,968	27,699	29,366	30,287	2.5%	2.8%	3.0%	3.0%
Administration	68,914	81,369	81,369	81,369	0	0.0%	83,403	86,697	90,916	93,643	2.5%	2.8%	3.0%	3.0%
Maintenance	142,775	142,700	144,200	144,200	0	0.0%	147,805	151,870	161,118	165,952	2.5%	2.8%	3.0%	3.0%
Total Supplies	525,826	537,549	527,149	527,149	0	0.0%	540,328	555,187	588,998	606,688	2.5%	2.7%	3.0%	3.0%
Electricity	576,123	584,044	453,525	453,555	40	0.0%	464,904	477,699	506,750	521,983	2.5%	2.8%	3.0%	3.0%
Fuel Oil	300,782	318,962	401,228	401,228	0	0.0%	411,258	422,588	448,302	461,751	2.5%	2.8%	3.0%	3.0%
Textbooks/Workbooks	172,875	170,879	161,178	161,178	0	0.0%	165,207	169,751	174,843	180,088	2.5%	2.8%	3.0%	3.0%
Library/Media Center	51,708	53,330	53,330	53,330	0	0.0%	54,663	56,166	59,587	61,375	2.5%	2.8%	3.0%	3.0%
Software	156,714	151,254	163,315	239,965	76,650	46.9%	179,304	201,735	214,021	220,441	2.5%	2.8%	3.0%	3.0%
Dues & Fees	36,214	36,722	38,867	38,867	0	0.0%	39,839	40,934	43,427	44,730	2.5%	2.8%	3.0%	3.0%
Replacement Equipment:														
Instructional	2,377	4,009	4,000	14,000	10,000	250.0%	14,350	14,745	15,187	15,643	2.5%	2.8%	3.0%	3.0%
Administration	2,689	2,500	2,500	2,500	0	0.0%	2,563	2,933	2,712	2,793	2.5%	2.8%	3.0%	3.0%
Maintenance	-	4,009	4,000	4,000	0	0.0%	4,100	4,213	4,339	4,469	2.5%	2.8%	3.0%	3.0%
Total Replacement Equipment	5,066	10,500	10,500	20,500	10,000	95.2%	21,013	21,590	22,238	22,905	2.5%	2.8%	3.0%	3.0%
New Equipment:														
Instructional	4,638	-	-	-	10,000	+100+	0	0	1,000	1,030	2.5%	2.8%	3.0%	3.0%
Administration	4,989	-	-	10,000	10,000	+100+	0	0	1,000	1,030	2.5%	2.8%	3.0%	3.0%
Maintenance	9,587	-	-	-	0	0	0	0	2,500	2,575	2.5%	2.8%	3.0%	3.0%
Total New Equipment	19,224	-	-	10,000	10,000	+100+	0	0	4,500	4,635	2.5%	2.8%	3.0%	3.0%
Student Activities	568,515	575,345	602,423	601,842	-781	-0.1%	616,683	632,100	651,053	670,595	2.5%	2.5%	3.0%	3.0%
Health	2,816,421	2,796,261	2,880,454	3,010,418	129,964	4.5%	3,323,264	3,660,806	3,984,280	4,368,666	10.4%	9.9%	8.4%	9.0%
Retirement Severance	200,000	200,000	200,000	200,000	0	0.0%	200,000	200,000	200,000	200,000	0.0%	0.0%	0.0%	0.0%
Other Employee Benefits	1,000,543	1,089,769	1,139,038	1,186,639	47,601	4.2%	1,216,305	1,255,574	1,301,612	1,342,204	2.5%	3.0%	3.0%	3.0%
Employee Benefits	4,016,564	4,086,021	4,219,492	4,387,057	177,565	4.2%	4,739,569	5,110,381	5,495,891	5,910,870	7.8%	7.8%	7.5%	7.3%
Start Up Costs														
Total Budget*	26,511,152	26,983,001	27,297,831	27,879,902	582,070	2.1%	28,742,547	29,723,875	30,706,891	31,922,875	33,043,945	3.4%	3.7%	3.5%
Annual Budget Change %							3.1%	3.4%	3.6%	3.7%				
Annual Change \$					562,645		981,128	1,063,216	1,135,984	1,121,070				

*FY13 Budget adjusted for +\$100K in reimbursed special services

**Summary of Large Capital Projections
FY14 – FY18**

1. Land Acquisition for Athletic Fields/Maintenance Facility
2. Athletics
3. Technology Upgrades
4. Emergency Generator
5. Maintenance and Facility Building
6. Wells Road Playing Field
7. District Efficiency Initiatives
8. Roof Replacement Schedule
9. High School Facility Upgrade
10. F.M. Kearns School Facility Renovation

Project	Priority	Gross Cost*	Net Cost	Projected Start Up	Ongoing	Projected Completion	Status
Land Acquisition for Athletic Fields/ Maint. Facility	1	~ \$500,000	~ \$500,000	Spring 2016		Spring 2017	Concept
Athletics	1	~ \$700,000	TBD	Summer 2015		Fall 2015	Concept
Technology Upgrade	1	\$345,000	TBD	Summer 2015		Fall 2015	Concept
Emergency Generator	1	\$130,000	TBD	Summer 2015		Fall 2015	Concept
Maintenance & Facility Bldg.	2	\$1,500,000	TBD	Summer 2016		Spring 2017	Concept
Wells Road Playing Field	2	\$75,000	\$75,000	Summer 2017		Fall 2017	Concept
District Efficiency Initiatives	3	\$900,000	TBD	Summer 2019		Fall 2019	Concept
Roof & Oil Tank Replacement	3	TBD	TBD	2017 & beyond		2017 & beyond	Placeholder
High School Facility Upgrade	3	\$1,150,000	TBD	Spring 2016	\$12,000	Fall 2017	Concept
F.M. Kearns School Facility	3	\$6,075,000	\$3,575,000	Spring 2017	\$30,000	Fall 2017	Concept

**GRANBY BOARD OF EDUCATION
Capital Project Summary**

PROJECT NAME: Land Acquisition for the Athletic Field Project and Maintenance and Facility Building

PROJECT SUMMARY:

The acquisition of between 10-15 acres of land is essential. Ideally, the land should be adjacent to or in close proximity of the high school facility to provide space for new athletic fields, parking and maintenance and storage facility building on the same site.

PROJECT CATEGORY: Placeholder Concept
 Fully Defined Priority Ranking

PROJECT BENEFITS:

- The sports program, town recreational program and community will be improved through the addition of adequate playing fields.
- Locating the maintenance and storage facility on the same site as the athletic fields provides immediate access to machinery and athletic equipment.
- A centralized storage facility will support cost-effective purchasing and accurate inventory control.

REFERENDUM: Winter 2015
PROJECT START: Spring 2016
PROJECT ON LINE: Spring 2017

LEGAL REQUIREMENTS:

- Connecticut State Department of Education School Construction Grant Program (limited funding).
- State and local code compliance.

IMPACT OF NOT PROCEEDING/DELAYING:

- Facilities will continue to be rented for storage and maintenance needs.
- The sports program will continue to suffer from too few playing fields. Some teams will continue to play offsite.

LAND ACQUISITION COST (FIELDS AND/OR PARKING): **≈ \$500,000**
• Approximately 10-15 acres

PROJECTED NET PROJECT COST: **≈ \$500,000**

**GRANBY BOARD OF EDUCATION
Capital Project Summary**

PROJECT NAME: Athletics

PROJECT SUMMARY:

The Granby Board of Education has identified the need for renovated and new athletic fields for many years. Major components of a more comprehensive plan are included in a \$3.2M school project that was part of the town's referendum approved in January, 2012. Remaining identified athletic needs dropped due to limited funding were and not included as part of the referendum project include:

Athletic Buildings \$500,000

Approximately 5,000 square feet is needed for athletic buildings at an approximate cost of \$100/square foot. The following building components are needed:

- *Offices:* Two offices are required for use by coaches. Each office should be equipped with a desk and telephone. Each should have an inside restroom adjacent to the office with a handicapped access toilet and shower. (Approximately 500 square feet)
- *Concession Stand:* A 500-square-foot concession stand will be needed for ticket sales and food/beverages sales.
- *Locker Rooms:* Two locker rooms are required for student use. Each should include lockers, benches, showers, and a team area. (Approximately 1,600 square feet)
- *Outside Restrooms:* Outside restrooms will be open to athletes and fans. The female restroom should include three stalls and 2 sinks. The male restroom should include two stalls, two urinals and two sinks. Both must be handicapped-accessible. (Approximately 600 square feet)
- *Storage:* Approximately 1,800-square-foot building is needed for athletic equipment.

Tennis Courts:

There is a programmatic and safety need to pave 6 tennis courts \$200,000

PROJECT CATEGORY: Placeholder Concept
 Fully Defined 1 Priority Ranking

PROJECT BENEFITS:

- The school sports program, town recreational program and community will be improved through the addition of these new facilities.

REFERENDUM: Winter 2014
PROJECT START: Summer 2015
PROJECT ON LINE: Fall 2015

LEGAL REQUIREMENTS:

- Connecticut State Department of Education School Construction Grant Program (limited funding).
- State and local code compliance.

IMPACT OF NOT PROCEEDING/DELAYING: Facilities will continue to be rented for storage and maintenance needs. Temporary storage units will be used. The tennis sports program will be negatively impacted by inadequate courts. Safety of the courts can only be assured through an annual \$10,000 short-term repair cost.

APPROXIMATE GROSS PROJECT COST: **≈ \$700,000**

NET COST: **TBD**

**GRANBY BOARD OF EDUCATION
Capital Project Summary**

PROJECT NAME: Technology Upgrade

PROJECT SUMMARY: The district has identified the need for technology upgrades in several different areas. These have been combined into a single project.

Mobile Computer Labs: (District) \$150,000
With increased use of technology each school has identified the need for additional computers accessible to classroom teachers and students for academic courses, assessment, and state mandated on-line testing. These needs can be addressed through the use of mobile computer labs. Included are 5 new mobile labs at a projected cost of \$30,000 per lab. If the Board decides to move forward with a district 1:1 computing program, funds could be allocated to support that program in place of this one.

Security Camera System Upgrades: (District) \$65,000
The COPS grant awarded in FY2007 paid for the basic infrastructure and wiring of all schools with a minimum level of security cameras and video storage capabilities (Max of up to 5 days recorded video storage). This project cost includes upgrades to the system to provide additional data/video storage capabilities and camera coverage of school public areas, school exteriors, and the new athletic fields that were not provided through the original project. Coverage in these areas will provide additional school security and protect against vandalism. The additional storage will allow saving of identified incidents for police review beyond the current capacity of about 5 days.

Phone System (High School) \$130,000
The telephone system at the high school is a legacy analog system 15 plus years old, out of warranty and at the end of its life cycle. Service providers and replacement parts are difficult to find. Cost includes replacement of the legacy PBX, office and classroom telephone sets.

PROJECT CATEGORY: Placeholder Concept
 Fully Defined 1 Priority Ranking

PROJECT BENEFITS:

- Addition of computer labs to provide additional access to electronic resources aiding in instruction.
- Replacement of outdated infrastructure.
- Improved school security and reduced vandalism.

REFERENDUM: Winter 2014
PROJECT START: Summer 2015
PROJECT ON LINE: Fall 2015

RELATED PROJECTS: COPS Grant and Board decisions on 1:1 computing.

HEALTH AND SAFETY IMPACT: A large part of the project addresses safety and security needs.

IMPACT OF NOT PROCEEDING/DELAYING: Instructional goals will be impacted. Failing infrastructure will have to be addressed in other ways. Security improvements will need to be addressed in other ways.

PROJECTED PROJECT COST: **\$345,000**

**GRANBY BOARD OF EDUCATION
Capital Project Summary**

PROJECT NAME: Emergency Generator

\$130,000

PROJECT SUMMARY: The district has identified the need for generators to protect schools from freezing pipes and spoiled food supplies during electrical service disruptions.

Portable 80 KW diesel generator (\$90,000)

When we lose power in the winter time, we must get the heating system restored before temperatures get to the point where pipes would freeze causing major disruption to the school schedule and major repair expenses. We also need year round protection against food spoilages caused by loss of freezers and refrigerators for the lunch programs when we lose electrical power. This generator is not sized to keep a school open; it will only meet our needs to prevent damages when utility power is disrupted.

Four (4) School transfer switches (\$40,000)

Transfer switches will need to be installed at each school (except MS, done by Town project) to connect a portable generator to the schools electrical system. Estimated installed cost is \$10,000 per school.

PROJECT CATEGORY: Placeholder Concept
 Fully Defined Priority Ranking

PROJECT BENEFITS:

- Prevents frozen pipes.
- Prevents lunch program food spoilage when power is lost.

REFERENDUM: Winter 2014
PROJECT START: Summer 2015
PROJECT ON LINE: Fall 2015

RELATED PROJECTS: Town generator installation at the Middle School to provide emergency shelter services.

HEALTH AND SAFETY IMPACT: This project will improve the ability of the district to respond to power losses and extreme weather events.

IMPACT OF NOT PROCEEDING/DELAYING: Freezing pipes cause major repair expenses and extended school closings.

PROJECTED PROJECT COST: **\$130,000**

PROJECTED NET PROJECT COST: **TBD**

**GRANBY BOARD OF EDUCATION
Capital Project Summary**

PROJECT NAME: Wells Road Playing Field

PROJECT SUMMARY: Land behind Wells Road School was donated to the town in 2009. In order to develop 5.6 acres of this area for use as field space, the area must be cleared of trees, a temporary road installed and the field leveled and seeded.

PROJECT CATEGORY: Placeholder Concept
 Fully Defined Priority Ranking

PROJECT BENEFITS:

- Expanded playground activities and possibly baseball and/or soccer field use.
- Additional resource for the town.

- **REFERENDUM:** Winter 2016
- **PROJECT START:** Summer 2017
- **PROJECT ON LINE:** Fall 2017

LEGAL REQUIREMENTS:

- State and local code compliance.

IMPACT OF NOT PROCEEDING/DELAYING: Donated land will sit idle.

PROJECTED GROSS COST: **\$ 75,000**

PROJECTED NET CAPITAL COST: **\$ 75,000**

**GRANBY BOARD OF EDUCATION
Capital Project Summary**

PROJECT NAME: District Efficiency Initiatives

PROJECT SUMMARY: The district has identified the need for a number of different efficiency initiatives. They are included for future consideration. Components of the project may need to be divided into individual projects in order to pursue grant funding.

- 1. HVAC Automation System for High School and Middle School: \$500,000**
Both the HS and MS automation systems that regulate and control the buildings heating and ventilating systems are nearing the end of their useful lives. The HS application system software support was dropped 3 years after the building was built 12 years ago, and the MS system is approaching 21 years old. Application software for both is no longer supported, and both systems are working on operating systems several to many generations newer than those they were designed for. The controllers these application systems operate to switch pumps on and off, and to open and close air dampers, etc. are becoming increasingly difficult to find when they break. All of the above factors raise concerns for long term reliability of the systems.

Realizing the risk of losing the ability to continue supporting these older systems, we are actively exploring migration of the systems to newer web-based applications as part of energy efficiency projects. If this approach does not prove fruitful, replacement of the application software and control mechanisms will be needed in the next 5-7 years.

- 2. Solar Panels: \$400,000**
This project will look at the payback of self-funding photovoltaic panels to generate electricity and solar panels for hot water if we are unable to find a satisfactory commercial lease arrangement.

PROJECT CATEGORY: Placeholder Concept
 Fully Defined Priority Ranking

PROJECT BENEFITS:

- Better climate for learning.
- Reduction in ongoing energy costs and reduction in energy usage.

REFERENDUM: Winter 2018
PROJECT START: Summer 2019
PROJECT ON LINE: Fall 2019

HEALTH AND SAFETY IMPACT: None

IMPACT OF NOT PROCEEDING/DELAYING: Loss of efficiency opportunity.

PROJECTED PROJECT COST: \$900,000

PROJECTED NET CAPITAL COST: TBD

**GRANBY BOARD OF EDUCATION
Capital Project Summary**

PROJECT NAME: High School Kitchen and Facilities Upgrade

PROJECT SUMMARY: With high school enrollment projected to stabilize at approximately 750 students, a kitchen is needed for a quality hot lunch program. Currently, lunch is transported from the middle school kitchen and served in the high school commons. This cost projection includes the construction of a 2,000 square foot addition on the end of the commons and necessary equipment and appliances.

Also, there are number of other needs, including air conditioning, sidewalk, and refurbishment of the tennis courts. Areas that need to be air conditioned: Commons, locker rooms, and athletic director's office. Six (6) tennis courts are in need of repaving and are addressed in the Athletics Project scheduled for fall 2015.

PROJECT CATEGORY: Placeholder Concept
 Fully Defined Priority Ranking

PROJECT BENEFITS:

- A higher quality hot lunch program will be offered.
- Increases use and productivity of spaces.

REFERENDUM: Fall 2015
PROJECT START: Spring 2016
PROJECT ON LINE: Fall 2017

LEGAL REQUIREMENTS:

- Connecticut State Department of Education School Construction Grant Program.
- State and local code compliance.

HEALTH AND SAFETY IMPACT: More inviting, nutritional meals will be served.

IMPACT OF NOT PROCEEDING/DELAYING: Food continues to be transported from the middle school, limiting meal choices. Spaces scheduled for A/C become unsuitable for their intended uses on very hot days.

APPROXIMATE GROSS PROJECT COST:		\$1,150,000
• Kitchen Construction (2,000 sq. ft. @ \$220)	\$ 475,000	
• Kitchen equipment/fixtures	\$ 300,000	
• Air conditioning	\$ 375,000	

NEW ONGOING COSTS: **\$12,000**

START-UP COSTS: **\$25,000**

APPROXIMATE NET PROJECT COST: **TBD**

- Projected at 35% SDE reimbursement; 90% eligible costs.

**GRANBY BOARD OF EDUCATION
Capital Project Summary**

PROJECT NAME: F.M. Kearns School Facility Addition

PROJECT SUMMARY: Even with updated enrollment projections showing a decline in primary enrollment projections, core facilities will need to be upgraded. The project includes dedicated spaces for a kitchen, gymnasium, and media center as well as additional conference rooms. The project also includes code compliance issues. Details are outlined in Educational Specifications adopted by the BOE and forwarded to the CT SDE by the Town of Granby in June 2002. In addition, we have recognized the need since then to resurface the primary parking lot. Professionally developed cost estimates based on 2002 construction costs would put the 2017 project cost at just over \$6M using 2% inflation. The cost estimate for today's market prices will need to be recalculated.

PROJECT CATEGORY: Placeholder Concept
 Fully Defined 3 Priority Ranking

PROJECT BENEFITS:

- Core facilities designed to meet educational needs.

REFERENDUM: Fall 2016
PROJECT START: Spring 2017
PROJECT ON LINE: Fall 2017

LEGAL REQUIREMENTS:

- Connecticut State Department of Education School Construction Grant Program.
- State and local code compliance.

RELATED PROJECTS:

HEALTH AND SAFETY IMPACT: Facilities will meet all new code requirements.

IMPACT OF NOT PROCEEDING/DELAYING: The educational environment will not be appropriate for primary age children and the school will remain the only school without contemporary core facilities.

PROJECTED PROJECT COST:	\$6,075,000
NEW ONGOING COSTS:	\$ 30,000
START-UP COSTS:	\$ 50,000
PROJECTED NET CAPITAL COST:	\$3,575,000

90% of project at 45.71% reimbursement. Costs adjusted to FY17.

Appendix A

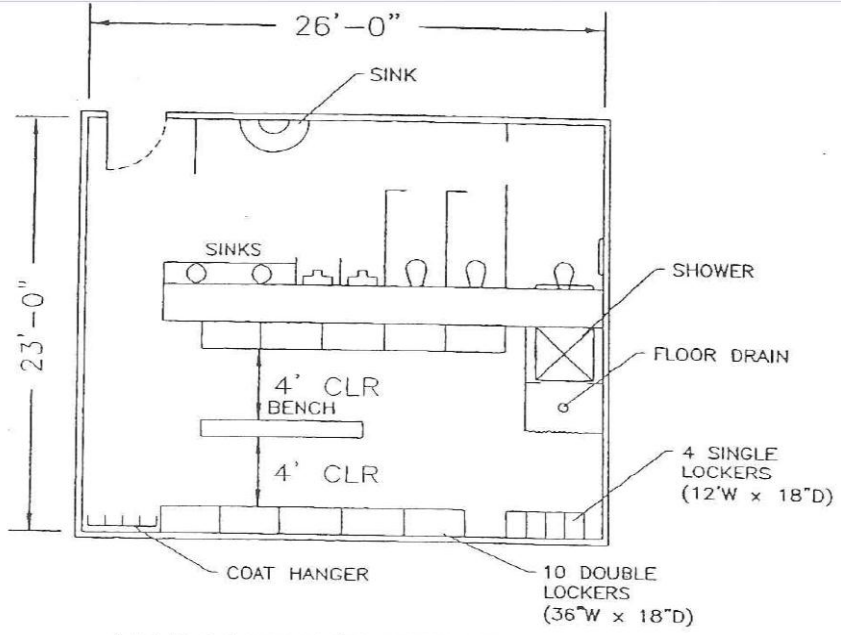

MALE LOCKER/SHOWER/TOILET
23' x 26' = 598 SF

WESTON & SAMPSON ENGINEERS, INC.

GRANBY, CONNECTICUT
AUGUST 08
BOE SPACE NEEDS ASSESSMENT

Scale: 1/8"=1'-0"

Sheet 4

b

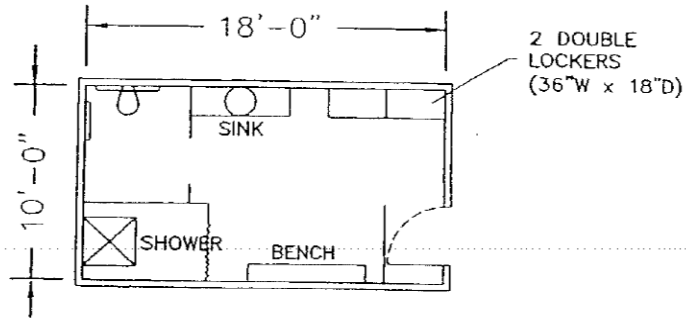

FEMALE LOCKER/SHOWER/TOILET
10' x 18' = 180 SF

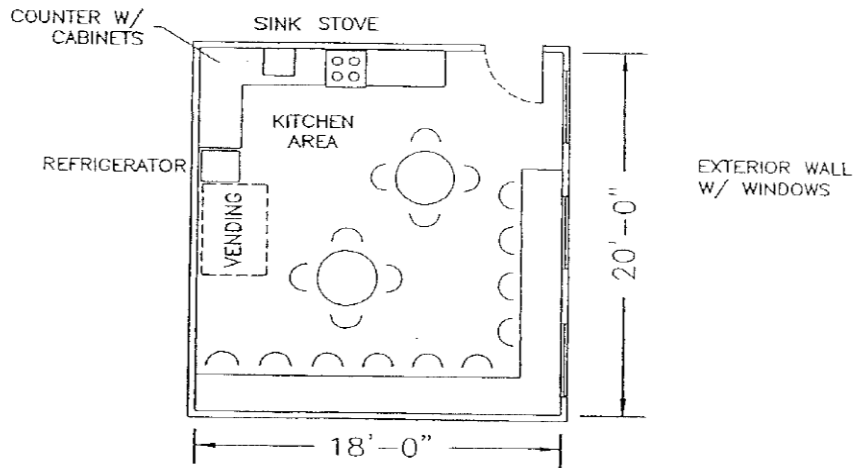

WORK FORCE LUNCH ROOM
18' x 20' = 360 SF

GRANBY, CONNECTICUT
AUGUST 08
BOE SPACE NEEDS ASSESSMENT

WESTON & SAMPSON ENGINEERS, INC.

Scale: 1/8"=1'-0"

Sheet 5

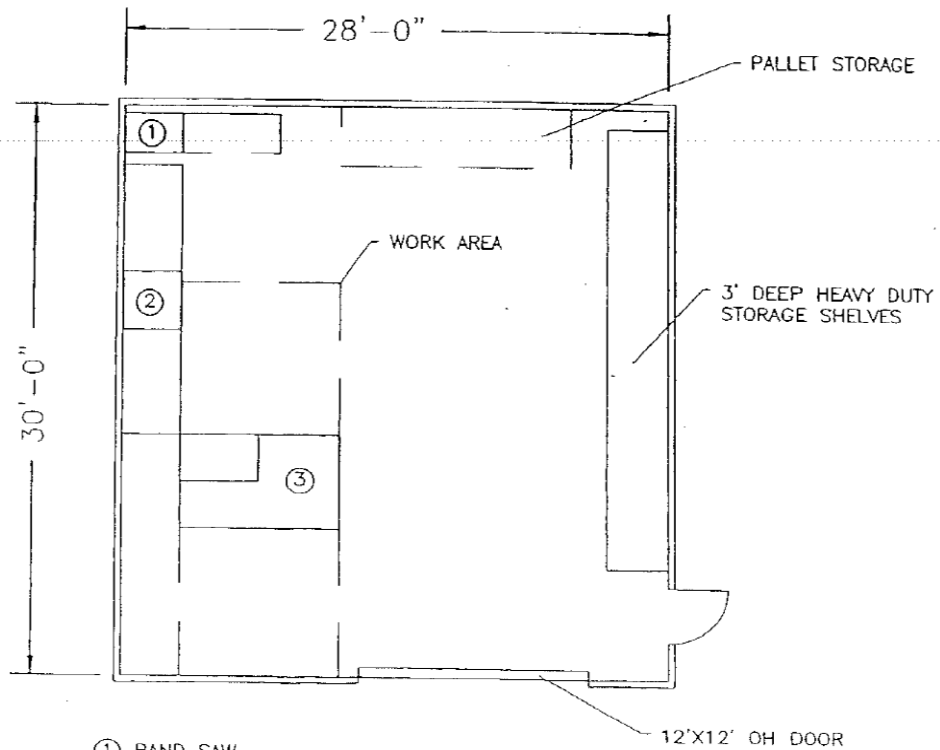

CARPENTRY SHOP
 28' x 30' = 840 SF

GRANBY, CONNECTICUT
 AUGUST 08
 BOE SPACE NEEDS ASSESSMENT

WESTON & SAMPSON ENGINEERS, INC.

Scale: 1/8"=1'-0" Sheet 6

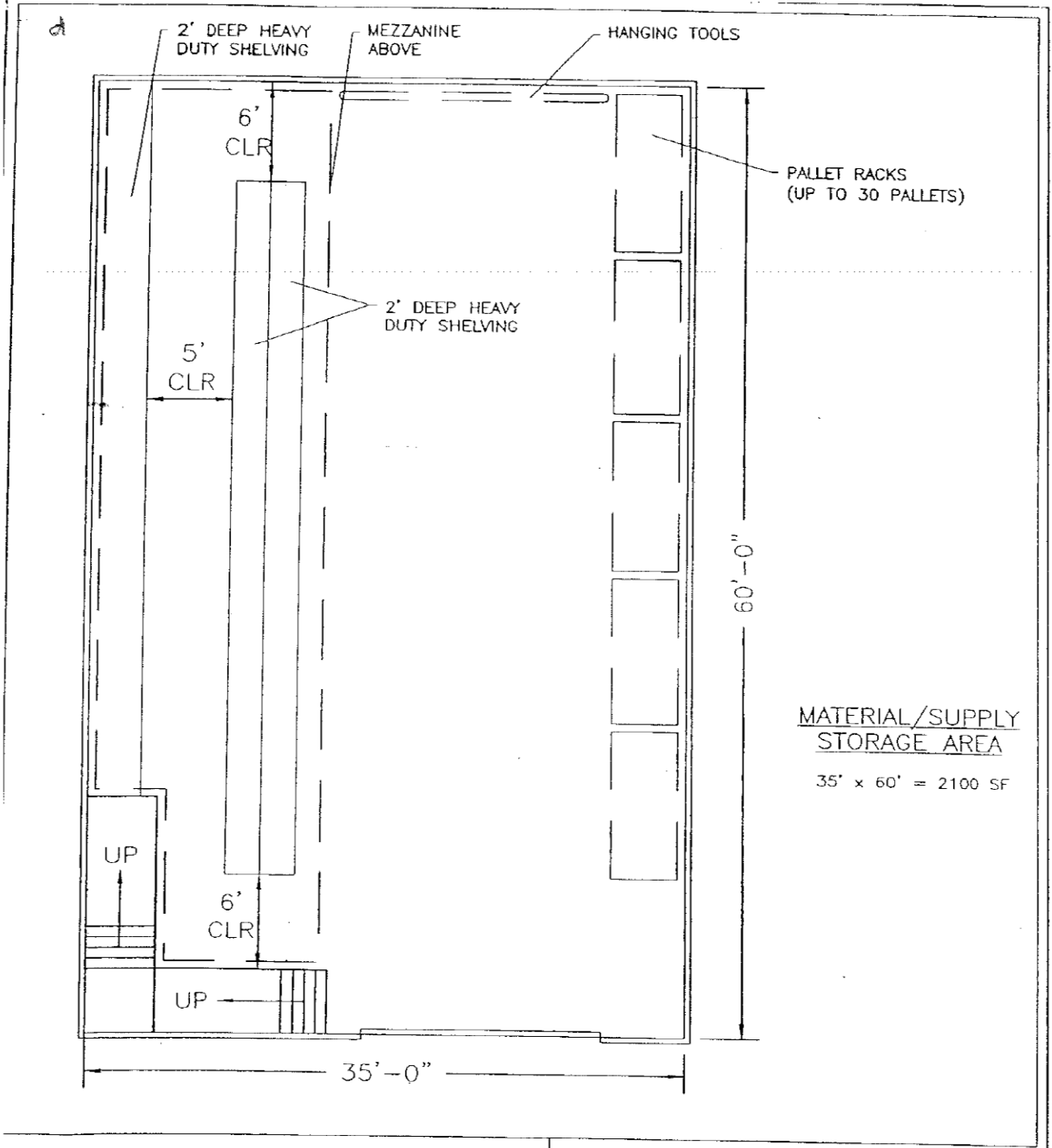

GRANBY, CONNECTICUT
 AUGUST 08
 BOE SPACE NEEDS ASSESSMENT

WESTON & SAMPSON ENGINEERS, INC.

Scale: 1/8" = 1'-0" Sheet 7

e

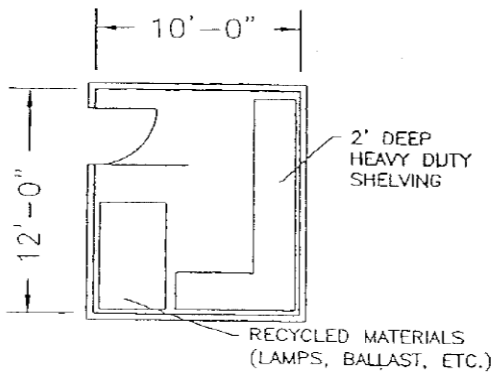

HAZARDOUS MATERIAL ROOM

10' x 12' = 120 SF

WESTON & SAMPSON ENGINEERS, INC.

GRANBY, CONNECTICUT
AUGUST 08
BOE SPACE NEEDS ASSESSMENT

Scale: 1/8"=1'-0"

Sheet 8

f

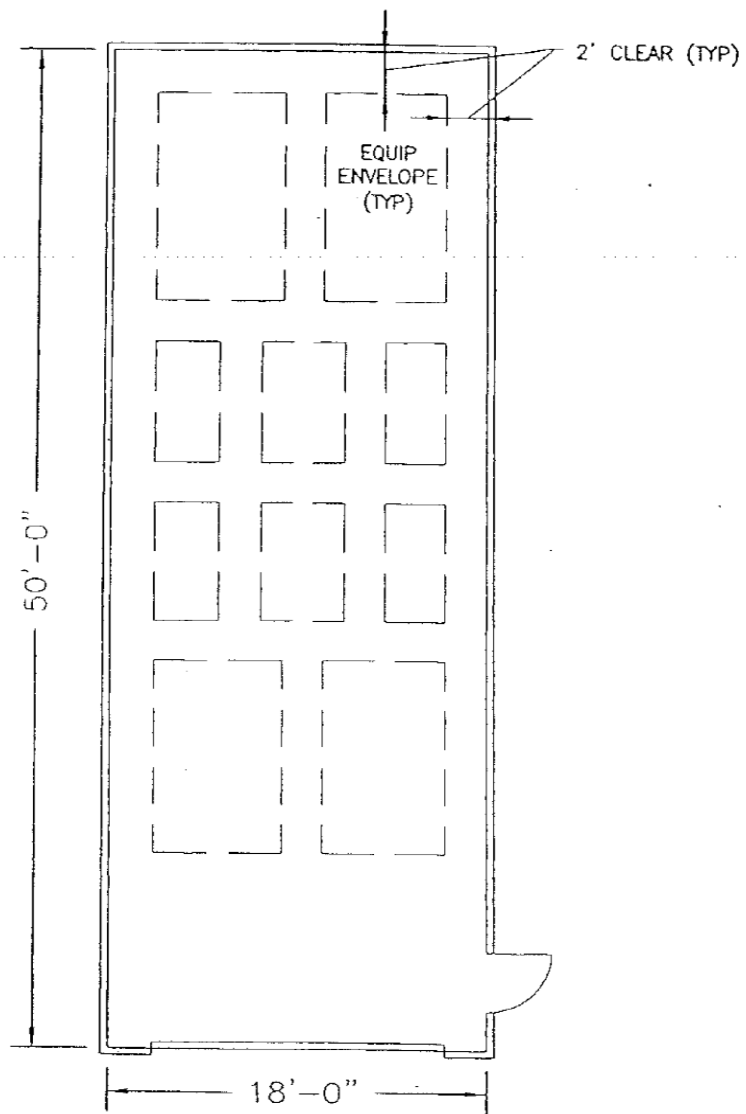

SMALL EQUIPMENT STORAGE

18' x 50' = 900 SF

GRANBY, CONNECTICUT

AUGUST 08

BOE SPACE NEEDS ASSESSMENT

Scale: 1/8"=1'-0"

Sheet 9

WESTON & SAMPSON ENGINEERS, INC.

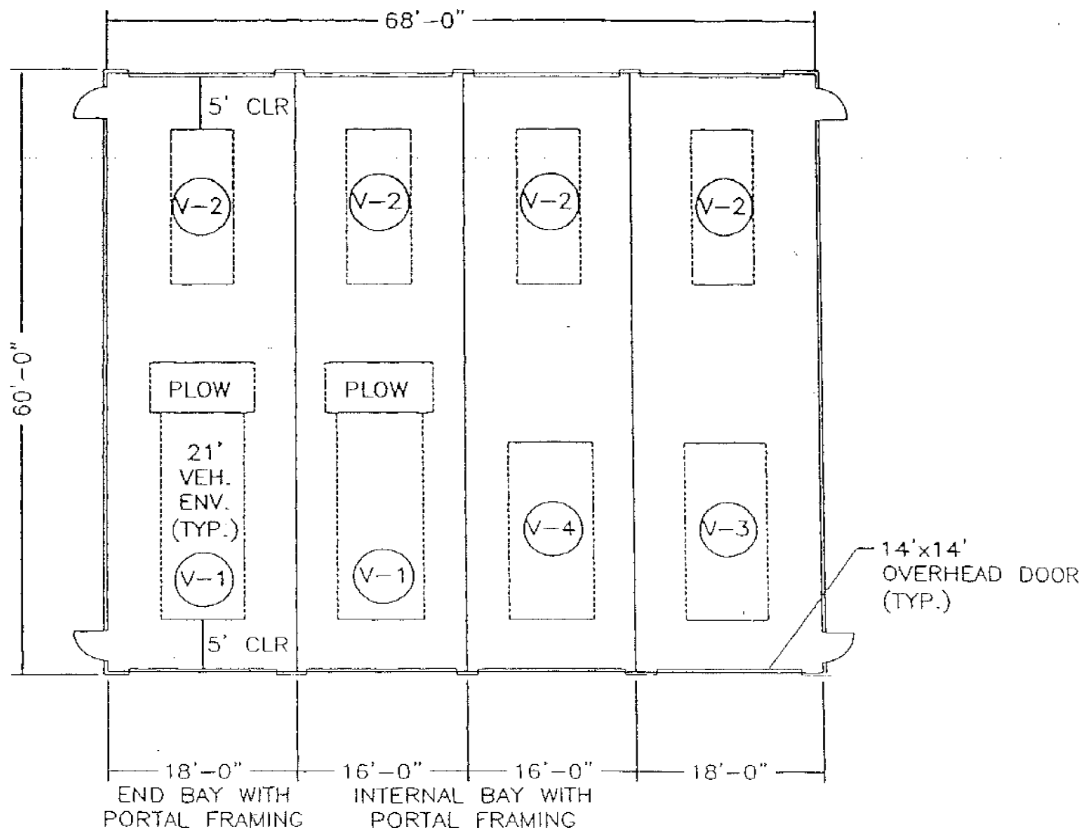

VEHICLE LIST

- V-1 : PICKUP TRUCK WITH PLOW
- V-2 : VAN
- V-3 : STUDENT TRANSPORT VAN
- V-4 : TRAILER

VEHICLE STORAGE AREA

60' x 68' = 4080 SF

NOTE: KITCHEN VAN
AND TECHNOLOGY VAN STORED
OUTSIDE

GRANBY, CONNECTICUT

AUGUST 08

BOE SPACE NEEDS ASSESSMENT

Scale: 1/16"=1'-0"

Sheet 10

WESTON & SAMPSON ENGINEERS, INC.

h

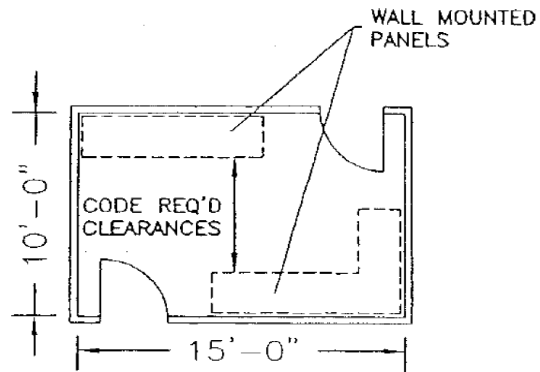

ELECTRIC ROOM
10' x 15' = 150 SF

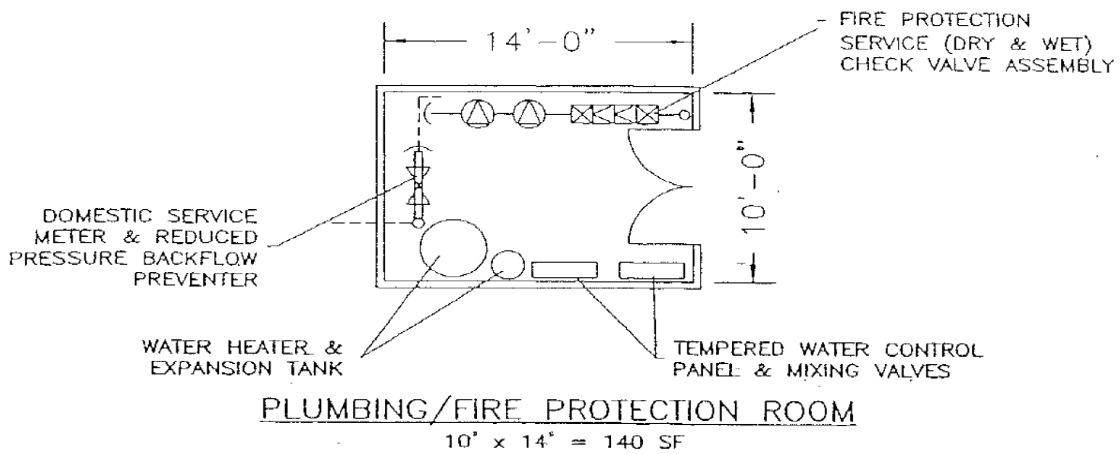

PLUMBING/FIRE PROTECTION ROOM
10' x 14' = 140 SF

WESTON & SAMPSON ENGINEERS, INC.

GRANBY, CONNECTICUT
AUGUST 08
BOE SPACE NEEDS ASSESSMENT

Scale: 1/16"=1'-0"

Sheet 11

Town of Granby CT
 Department of Public Works / Board of Education
 Space Needs Summary
 August 2008

Building Requirements

Area	Description	Size (SF)	Sheet No.	Ref No.	Room / Area Dimensions		
					length	width	size
DPW Space Needs	Vehicle Storage Area	1,540	1	D 0.00	22	70	1,540
	Wash Bay	1,750	2	D 4.03 **	25	70	1,750
	Wash Equipment Room	360	2	D 4.03 **	18	20	360
	Small / Towed Equipment Storage	5,600	3	D 0.00	70	80	5,600
	Subtotal:	9,250					
	Area Grossing Factor (5%):	463					
	Circulation:	(included)					
	TOTAL:	9,713					
	Requested:	8,480					
BOE Space Needs	Male Locker/Shower/Toilet	598	4	B 1.09	23	26	598
	Female Locker/Shower/Toilet	180	5	B 1.11	10	18	180
	Workforce Lunch Room	360	5	B 2.07	18	20	360
	Carpentry Shop	840	6	C 1.06	28	30	840
	Material/Supply Storage Area	2,100	7	D 0.00	35	60	2,100
	Hazardous Material Storage Area	120	8	C 9.16 **	10	12	120
	Small Equipment Storage Area	900	9	C 9.02 **	18	50	900
	Vehicle Storage Area	4,080	10	D 2.08	60	68	4,080
	Electric Room	150	11	B 5.01	10	15	150
	Plumbing/Fire Protection Room	140	11	B 5.02	10	14	140
	Subtotal:	9,468					
	Area Grossing Factor (10%):	947					
	Circulation (10%):	1,041					
	TOTAL:	11,456					
Requested:	8,060					(plus lunchroom/restrooms/lockerspace)	

Curriculum/Policy/Technology/Communications Subcommittee Meeting Minutes
December 5, 2012, 5:30 p.m.
Central Services

Present:

Alan Addley
Diane Dugas
Jenny Emery
Bob Gilbert
Ben Perron
Rosemarie Weber

Meeting commenced at: 5:40 p.m.

Meeting adjourned at: 7:00 p.m.

- I. Policies: a) Reviewed non-discrimination policy and administrative regulations; b) recommend bringing forward to entire Board; c) Community Relations policy discussed, revisions made, recommend bringing to entire Board; d) IEP policy discussed; and, e) Advertising Policy – in light of athletic fields and Zippslip, subcommittee looking for context to assess changes to the policy.

- II. Curriculum Director's Report: Discussed PD in district this November. Some highlights include: positive school climate, Title IV training in Kearns, Kelly and Wells and work on writing/review analysis with K-6 literacy specialists; moving forward with action plan to improve student writing in the district.

- III. New Texts: Two (2) English books being considered; text for Mandarin Chinese IV as well as new course proposal to consider; math text to align to Common Core – no one text addresses best so looking at a variety of resources.

- IV. Other: N/A

**Finance/Personnel/Facilities Subcommittee Meeting Minutes
December 5, 2012, 5:30 p.m.
Central Services**

Attendance:

Ed Ohannessian	Present	Alan Addley	Absent
Ron Walther	Present	Bill Arnone	Present
Lynn Guelzow	Absent	Tom Steinke	Present
		Harry Traver	Present

Meeting commenced at: 5:35 p.m.

Meeting adjourned at: 7:00 p.m.

1. Eagle Scout Project: Discussed and approved Bill Arnone's project at Kearns School for his Eagle Scout Project.
2. November Statement of Accounts: Operating budget looks good as of November. Changes in special education accounts (2 new students) added considerable expense.
3. Solar Project: Discussed two potential proposals and decided to continue to exploring with Green Point. Will get more data from Darien and Milford school systems regarding actual experience.
4. CPPAC: Reviewed list of items on the CPPAC submission.
5. Other: None

January 1	New Year's Day – No School		
January 2	Curriculum Subcommittee Meeting BOE Meeting	5:30 p.m. 7:00 p.m.	Central Services Central Services
January 5	Holly Ball	7:00-10:30 p.m.	Community Gym
January 9	Special Board Meeting	7:00 p.m.	Central Services
January 10	Junior Planning Night	7:00 p.m.	HS Auditorium
January 10	GMMS Winter Chorus Concert	7:00 p.m.	MS Gymnasium
January 12	Holly Ball (Snow Date)	7:00-10:30 p.m.	Community Gym
January 14	Junior Planning Night (Snow Date)	7:00 p.m.	HS Auditorium
January 16	Finance Subcommittee Meeting BOE Meeting	5:30 p.m. 7:00 p.m.	Central Services Central Services
January 17	WR 5 th /6 th Grade Band Concert	7:00 p.m.	WR Gymnasium
January 21	Martin Luther King - No School		Offices Closed
January 22-25	HS Exams – Early Release		
January 23	KL Winter Concert (All Ensembles)	7:00 p.m.	KL Gymnasium
January 24	Professional Development Early Release – All Schools		
January 31	GMMS Winter Band Concert	7:00 p.m.	HS Auditorium