



Canutillo ISD

Finance/Audit/Facilities/Planning Committee Meeting

Wednesday, October 15, 2014 6:00 PM

Agenda of Finance/Audit/Facilities/Planning Committee Meeting

The Board of Trustees Canutillo ISD

A Finance/Audit/Facilities/Planning Committee Meeting of the Board of Trustees of Canutillo ISD will be held October 15, 2014, beginning at 6:00 PM in the Canutillo ISD Administration Office - 7965 Artcraft - El Paso, Texas.

The subjects to be discussed or considered or upon which any formal action may be taken are as listed below. Items do not have to be taken in the order shown on this meeting notice.

1. GENERAL FUNCTIONS

A. Call to Order

B. Roll Call

Laure Searls, Chairperson; Sergio Coronado and Adrian Medina

2. COMMITTEE BUSINESS

All committee business items are for discussion and possible formulation of recommendation to the Board of Trustees

A. FACILITIES

- | | |
|--|----|
| 1. October 2014 Bond Update | 4 |
| Presenter: D. Padilla, E. Goytia | |
| 2. CHS, Contingency Change Request # 1 - Sanitary Sewer Manhole | 54 |
| Presenter: D. Padilla, E. Goytia | |
| 3. CHS, Contingency Change Request # 2 - IT Fiber Optic Relocation | 59 |
| Presenter: D. Padilla, E. Goytia | |
| 4. CHS, Contingency Change Request # 4 - Soils Testing Budget Increase | 66 |
| Presenter: D. Padilla, E. Goytia | |
| 5. Reyes, Change Order # 2 | 69 |
| Presenter: D. Padilla, E. Goytia | |

B. REPORT

- | | |
|----------------------|-----|
| 1. CTE Plan | 100 |
| Presenter: J. Massie | |

C. FINANCE

Presenter: M. Aguirre

- | | |
|--|-----|
| 1. Warrant Report for the Period of September 1 through September 30, 2014 | 105 |
| 2. Report to the Board of Trustees - September Financials | |

- 3. Discussion and Recommendation Regarding Budget Amendments 106
- 4. Clarification Regarding the Response to TEA Annual Financial Compliance Report Review 139
Presenter: M. Aguirre

D. AUDIT

Presenter: H. Rodriguez

- 1. Internal Audit Plan Update
Presenter: H. Rodriguez
- 2. Compliance Calendar
Presenter: H. Rodriguez
- 3. Hotline Update
Presenter: H. Rodriguez

E. PURCHASING

Presenter: M. Aguirre

- 1. Discussion and recommendation regarding purchase of Fresh Fruits and Vegetables from Segovia's Distributing Inc. - Amount \$130,000.00 140
Presenter: V.Garcia/M.Aguirre
- 2. Discussion and recommendation regarding award of grease trap services from Valley By Products - Amount \$11,340.00 147
Presenter: V.Garcia/M.Aguirre
- 3. Discussion and recommendation regarding the purchase of a well pump for Bill Childress Elementary School from Total Mechanical Contractors - \$12,000.00 151
Presenter: D.Padilla/V.Garcia

3. COMMUNITY INPUT

Comments/Input from community members on items discussed by the Finance/Audit/Facilities/Planning Committee

4. ADJOURNMENT

If, during the course of the meeting, discussion of any item on the agenda should be held in a closed meeting, the Board will conduct a closed meeting in accordance with the Texas Open Meetings Act, Government Code, Chapter 551, Subchapters D and E. Before any closed meeting is convened, the presiding officer will publicly identify the section or sections of the Act authorizing the closed meeting. All final votes, actions, or decisions will be taken in open meeting.

The notice for this meeting was posted in compliance with the Texas Open Meeting Act on _____, at _____.

For the Board of Trustees



BOND PROJECT SUMMARY REPORT

October 2014

Bond Project Team

Dominic Padilla, LEED AP

Executive Director of Facilities and Transportation

Edgar Goytia

Bond Project Manager

Arlene Garcia

Field Project Superintendent

BOND 2006 & 2011

UNDER CONSTRUCTION



Canutillo High School

Architect: Dimensions Partnership

Contractor: Banes

ID	PROJECT	PROPOSED PROJECT AMOUNT	BOND SERIES 2006	BOND SERIES 2011	BOND SERIES 2013	TOTAL AMENDED PROJECT BUDGET	ENCUMBRANCE \$ 09/30/2014	PROJECT EXPENSES TO DATE 09/30/2014	BUDGET BALANCE REMAINING	COMMENTS/STATUS	% COMMITTED	% SPENT
107	Gym: Addition with One Side Seating	\$ 2,100,000	\$ -	\$ 1,084,204		\$ 1,084,204	\$ 705,261	\$ 378,943	\$ (0)		100%	35%
					\$ 1,482,521	\$ 1,482,521	\$ 1,129,189	\$ 338,371	\$ 14,961		99%	23%
114	Locker Room: Girl Locker Room Upgrades	\$ 10,000	\$ -	\$ 11,691	\$ -	\$ 11,691	\$ 9,444	\$ 2,246	\$ 1		100%	19%
116	Subsidence at Plaza / Buttreassing at Courts	\$ 85,000	\$ -	\$ 72,277	\$ -	\$ 72,277	\$ 33,013	\$ 39,263	\$ 1		100%	54%
106	Baseball Field: Upgrades	\$ 130,000	\$ -	\$ 6,249	\$ -	\$ 6,249	\$ 1,040	\$ 5,209	\$ 0	Postponed		
112	Fencing: Wall Ball Courts	\$ 25,000	\$ -	\$ 3,149	\$ -	\$ 3,149	\$ 420	\$ 2,729	\$ 0	Postponed		
113	Electrical: Lighting: Upgrades: Auditorium	\$ 17,000	\$ -	\$ -	\$ -	\$ -		\$ -	\$ -	Postponed		
115	Outdoor Eating Area Improvements: La Sombrilla	\$ 150,000	\$ -	\$ 11,949	\$ -	\$ 11,949	\$ 2,180	\$ 9,769	\$ 0	Postponed		
117	Renovation: Weight Room Conversion	\$ 12,000	\$ -	\$ 3,738	\$ -	\$ 3,738	\$ 624	\$ 3,113	\$ 1	Postponed		

Project Notes:

Major Activities:

The project is 36% Complete. Contractor working on building retaining wall

Key Issues:

None at this time



Silvestre and Carolina Reyes - Pre-k to 5th

Architect: Carl Daniels Architects

Contractor: Vemac

ID	PROJECT	PROPOSED PROJECT AMOUNT	FOOD SERVICE FUND BALANCE	BOND SERIES 2006	BOND SERIES 2011	BOND SERIES 2013	TOTAL AMENDED PROJECT BUDGET	ENCUMBRANCES 09/30/2014	PROJECT EXPENSES TO DATE 09/30/2014	BUDGET BALANCE REMAINING	COMMENTS/Status	% COMMITTED	% SPENT
83	Campus Construction	\$ 15,250,000		\$ -	\$ 2,571,319	\$ -	\$ 2,571,319	\$ 50,000	\$ 2,479,975	\$ 41,344		98%	96%
						\$ 13,983,002	\$ 13,983,002	\$ 8,573,977	\$ 4,987,061	\$ 421,965		97%	36%
87	Furniture and Equipment	\$ 355,000		\$ -	\$ -	\$ 355,000	\$ 355,000	\$ -	\$ -	\$ 355,000		0%	0%
88	Technology Equipment	\$ 450,000		\$ -	\$ -	\$ 450,000	\$ 450,000	\$ -	\$ -	\$ 450,000		0%	0%
89	Technology Infrastructure	\$ 320,000		\$ -	\$ -	\$ 320,000	\$ 320,000	\$ -	\$ -	\$ 320,000		0%	0%
85	Campus Construction	\$ 2,127,906		\$ 3,913,039	\$ -	\$ -	\$ 3,913,039	\$ 2,735,417	\$ 1,026,305	\$ 151,317		96%	26%
86	Architect/Construction Fees	\$ 2,259,602		\$ 2,267,980	\$ -	\$ -	\$ 2,267,980	\$ 316,722	\$ 1,098,520	\$ 852,739		62%	48%
	Kitchen Equipment		\$ 515,500				\$ 515,500	\$ 417,661	\$ 4,617	\$ 93,222		82%	1%

Project Notes:

Major Activities:

The project is 53% Complete. Work in progress: Ductwork, interior framework, site work, and electrical

Key Issues:

None at this time



Alderete Middle School

Architect: GA Architecture
Contractor: BANES

ID	PROJECT	PROPOSED PROJECT AMOUNT	GENERAL FUND BALANCE	BOND SERIES 2006	BOND SERIES 2011	TOTAL AMENDED PROJECT BUDGET	ENCUMBRANCES 09/30/2014	PROJECT EXPENSES TO DATE 09/30/2014	BUDGET BALANCE REMAINING	COMMENTS/STATUS	% COMMITTED	% SPENT
122	Landscaping: Upgrades (related to Gym Add.)	\$ 71,342	\$ -	\$ 5,000	\$ -	\$ 5,000	\$ 2,625	\$ 2,375	\$ -		100%	48%
123	Gym: Addition	\$ 2,000,000	\$ -	\$ -	\$ 1,769,511	\$ 1,769,511	\$ 1,357,597	\$ 405,789	\$ 6,124		100%	23%
123					\$ 1,137,466	\$ 1,137,466	\$ 795,289	\$ 198	\$ 341,979		70%	0%
123				\$ 431,070		\$ 431,070	\$ -	\$ 431,070	\$ -		100%	100%
123			\$ 628,062	\$ -	\$ -	\$ 628,062	\$ 628,062	\$ -	\$ -		100%	0%
124	Band/Music Room: Fine Arts Expansion and Upgrades	\$ 940,000	\$ -	\$ -	\$ 247,900	\$ 247,900	\$ 173,231	\$ 55,783	\$ 18,886		92%	23%
128	ADA: Compliance Issues	\$ 35,000	\$ -	\$ -	\$ 73,391	\$ 73,391	\$ 58,306	\$ 15,585	\$ (500)		101%	21%
129	Flooring: Existing Gym. Wall to wall floor replacement.	\$ 205,000	\$ -	\$ -	\$ 139,444	\$ 139,444	\$ 33,113	\$ 102,131	\$ 4,200		97%	73%
133	Roof: Replace Translucent Panels	\$ 85,000	\$ -	\$ -	\$ 42,307	\$ 42,307	\$ 40,908	\$ 1,399	\$ 0		100%	3%
125	Electrical: Lighting: Safety Lighting for Football Field	\$ 30,000	\$ -	\$ -	\$ -	\$ -	\$ -	\$ -	\$ -	Postponed		
127	Pedestrian Path: To East Exit High Ridge	\$ 30,000	\$ -	\$ -	\$ 2,625	\$ 2,625	\$ -	\$ 2,625	\$ -	Postponed		
130	Electrical: Lighting: Exterior Upgrades	\$ 85,000	\$ -	\$ -	\$ -	\$ -	\$ -	\$ -	\$ -	Postponed		
131	Renovation: Weight and Locker Room	\$ 760,000	\$ -	\$ -	\$ 56,000	\$ 56,000	\$ -	\$ 42,000	\$ 14,000	Postponed		
132	Renovation: New Faculty Restroom	\$ 78,000	\$ -	\$ -	\$ 6,000	\$ 6,000	\$ -	\$ 4,500	\$ 1,500	Postponed		

12

Project Notes:

Major Activities:

The project is 48% Complete. Contractor working on Brick facade, interior framing and plumbing

Issues:

None at this time



Northwest Early College High School

Architect: GA Architecture

Contractor: BANES

ID	PROJECT	PROPOSED PROJECT AMOUNT	GENERAL FUND BALANCE	BOND SERIES 2006	BOND SERIES 2011	TOTAL AMENDED PROJECT BUDGET	ENCUMBRANCES 09/30/2014	PROJECT EXPENSES TO DATE 09/30/2014	BUDGET BALANCE REMAINING	COMMENTS/ STATUS	% COMMITTED	% SPENT
118	Canopy	\$ 35,000	\$ -	\$ -	\$ 35,000	\$ 35,000	\$ 1,000	\$ 1,500	\$ 32,500		7%	4%
119	PA System	\$ 15,000	\$ -	\$ 15,000		\$ 15,000	\$ 1,125	\$ 375	\$ 13,500		10%	3%
120	Kitchen-Cafeteria Multi-Purpose Room	\$ -	\$ 1,125,000	\$ 102,635		\$ 1,227,635	\$ 9,700	\$ 76,110	\$ 1,141,825		7%	6%

Project Notes:

Major Activities: Project has not started; Under design

Key Issues: None at this time

Deanna Davenport Elementary School

Architect: GA Architecture

Contractor: TBD

ID	PROJECT DESCRIPTION	PROPOSED PROJECT AMOUNT	BOND SERIES 2006	BOND SERIES 2011	TOTAL AMENDED PROJECT BUDGET	ENCUMBRANCES 09/30/2014	PROJECT EXPENSES TO DATE 09/30/2014	BUDGET BALANCE REMAINING	COMMENTS/ STATUS	% COMMITTED	% SPENT
63	Playground: Upgrades: Repaint, Refurbish and Resurface Play Courts & Basketball Courts	\$ 78,000	\$ -	\$ 87,650	\$ 87,650	\$ 2,950	\$ 7,483	\$ 77,218		12%	9%
65	Site: Soccer Field Upgrades /	\$ 100,000	\$ -	\$ 117,293	\$ 117,293	\$ 6,324	\$ 30,039	\$ 80,930		31%	26%

15

Project Notes:

Major Activities: These projects are under design

Key Issues: None at this time

100% Design Development Drawings

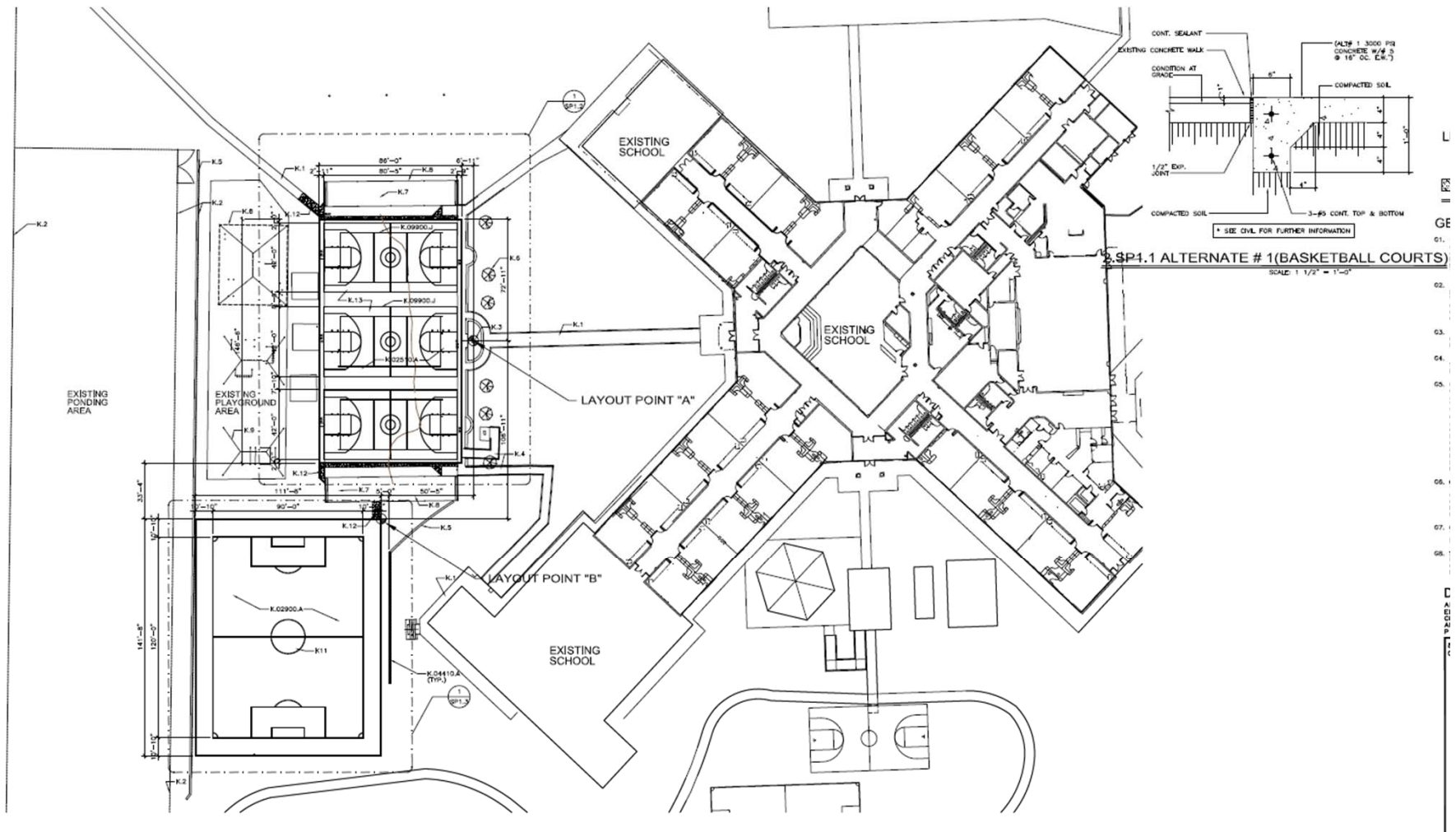



QUESTIONS?



Jose Damian Elementary School Complete

Architect: Dimensions Partnership
Contractor: BYERS

ID	PROJECT	PROPOSED PROJECT AMOUNT	BOND SERIES 2006	BOND SERIES 2011	PROJECT BUDGET	ENCUMBRANCES 04/30/2014	PROJECT EXPENSES TO DATE 04/30/2014	BUDGET BALANCE REMAINING	Comments	% SPENT
77	Fencing: Campus	\$ 16,500	\$ 29,390	\$ -	\$ 29,390	\$ 1,118	\$ 29,938	\$ (1,666)	Complete	106%
81	Life Safety: Fire-Rated Door	\$ 72,000	\$ -	\$ 152,284	\$ 152,284	\$ 136,934	\$ 11,615	\$ 3,734	Complete	98%
79	Playground: Equipment	\$ 19,000	\$ 19,000	\$ -	\$ 19,000	\$ -	\$ 19,000	\$ 0	Complete	100%
82	ADA: Playground Area	\$ 12,000	\$ -	\$ 61,308	\$ 61,308	\$ -	\$ 61,228	\$ 81	Complete	100%
76	Electrical: Lighting Upgrade: Exterior	\$ 25,000	\$ -	\$ 17,757	\$ 17,757	\$ -	\$ 17,757	\$ -	Complete	100%
78	Flooring: Kitchen Floor Upgrades	\$ 58,000	\$ -	\$ 4,339	\$ 4,339	\$ -	\$ 4,338	\$ 1	Postponed	0%

19

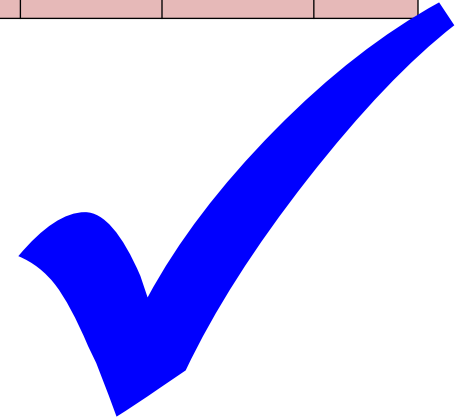

Project Notes:

Major Activities:

The project is 100% Complete.

Key Issues:

None at this time



Canutillo Elementary School Complete

Architect: Philo Wilke
Contractor: Byers

ID	PROJECT	PROPOSED PROJECT AMOUNT	BOND SERIES 2006	BOND SERIES 2011	PROJECT BUDGET	ENCUMBRANCES 04/30/2014	PROJECT EXPENSES TO DATE 04/30/2014	BUDGET BALANCE REMAINING	COMMENTS	% SPENT
33	ADA: Sidewalk Extension / Expansion: From Blacktop to Playground	\$ 80,000	\$ -	\$ 139,190	\$ 139,190	\$ 9,505	\$ 129,684	\$ 1	Complete	93%
34	ADA: Grass Play Area and Irrigation: Sidewalk Inside Oval	\$ 136,444	\$ 113,970	\$ -	\$ 113,970	\$ (0)	\$ 113,970	\$ 0	Complete	100%
	ADA: Grass Play Area and Irrigation: Sidewalk Inside Oval	\$ 112,000	\$ -	\$ 113,447	\$ 113,447		\$ 113,446	\$ 1	Complete	100%
36	Fencing: Campus	\$ 16,500	\$ 108,090	\$ -	\$ 108,090	\$ 24,612	\$ 83,285	\$ 193	Complete	77%
42	ADA: Blacktop Resurfacing	\$ 345,823	\$ 364,498	\$ -	\$ 364,498	\$ 2,346	\$ 366,303	\$ (4,150)	Complete	100%
	ADA: Blacktop Resurfacing	\$ 30,000	\$ -	\$ 118,247	\$ 118,247	\$ 457	\$ 111,002	\$ 6,788	Complete	94%
43	Drop-Off / Pick-Up Upgrades	\$ 160,000	\$ -	\$ 193,887	\$ 193,887	\$ 16,179	\$ 153,417	\$ 24,291	Complete	79%

21

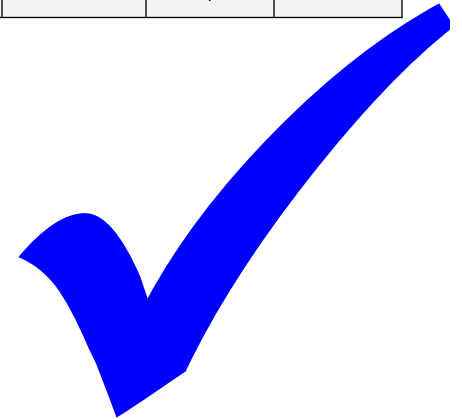

Project Notes:

Major Activities:

The project is 100% Complete.

Key Issues:

None at this time

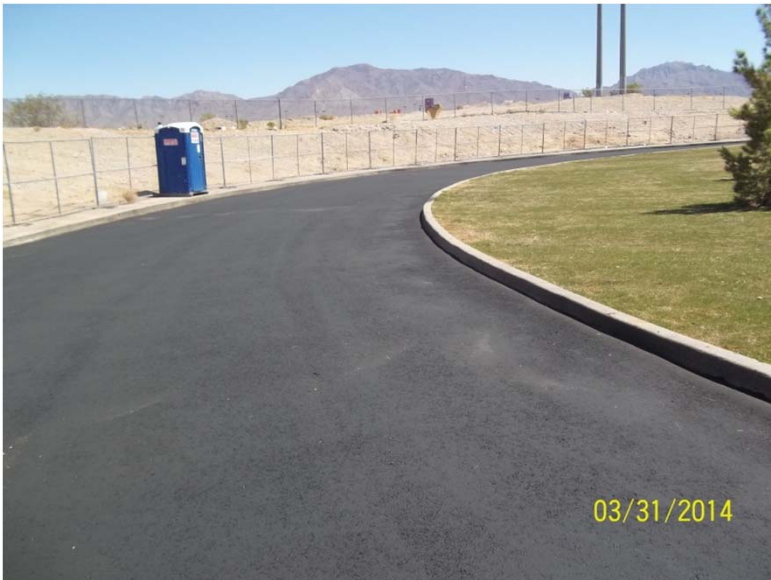

Bill Childress Elementary School

Complete

ID	PROJECT	PROPOSED PROJECT AMOUNT	BOND SERIES 2006	BOND SERIES 2011	PROJECT BUDGET	ENCUMBRANCES 04/30/2014	PROJECT EXPENSES TO DATE 04/30/2014	BUDGET BALANCE REMAINING	Comments	% SPENT
21	Irrigation System: Grass Areas	\$ 30,000	\$ -	\$ 71,071	\$ 71,071	\$ 1,715	\$ 65,060	\$ 4,296	Complete	94%
26	Paint: Campus	\$ 40,000	\$ -	\$ 75,396	\$ 75,396	\$ 3,211	\$ 72,182	\$ 3	Complete	100%
23	Lift Station: Upgrade	\$ 40,000	\$ 5,126	\$ -	\$ 5,126	\$ -	\$ 4,365	\$ 761	Complete	85%
20	Electrical: Lighting Upgrade: Exterior	\$ 25,000	\$ -	\$ 19,017	\$ 19,017	\$ -	\$ 19,017	\$ 0	Complete	100%
22	Playground: Equipment	\$ 19,000	\$ 2,235	\$ -	\$ 2,235	\$ -	\$ 2,235	\$ -	Complete	100%
24	ADA: Drinking Fountains	\$ 8,000	\$ 3,698	\$ 7,107	\$ 10,805	\$ -	\$ 10,804	\$ 1	Complete	100%
29	Wetland Upgrades	\$ 100,000	\$ 141,257	\$ -	\$ 141,257	\$ -	\$ 141,256	\$ 0	Complete	100%
30	ADA: Playground Area	\$ 12,000	\$ -	\$ 11,621	\$ 11,621	\$ -	\$ 11,620	\$ 1	Complete	100%
31	Playground: Upgrade	\$ 30,000	\$ -	\$ 30,000	\$ 30,000	\$ -	\$ 29,999	\$ 1	Complete	100%

23

Project Notes:

Major Activities:

The project is 100% Complete

Key Issues:

None at this time

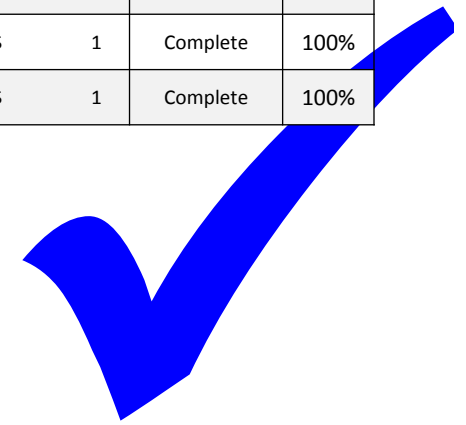

Gonzalo & Sofia Garcia Elementary School

Complete

ID	PROJECT	PROPOSED PROJECT AMOUNT	BOND SERIES 2006	BOND SERIES 2011	PROJECT BUDGET	ENCUMBRANCES 04/30/2014	PROJECT EXPENSES TO DATE 04/30/2014	BUDGET BALANCE REMAINING	Comments	% SPENT
73	ADA: Grass Play Area	\$ 30,000	\$ -	\$ 52,344	\$ 52,344	\$ 1,522	\$ 50,817	\$ 5	Complete	100%
71	Lift Station: Upgrade	\$ 40,000	\$ -	\$ 11,475	\$ 11,475	\$ -	\$ -	\$ 11,475	Postponed	0%
69	Canopy	\$ 38,000	\$ -	\$ 37,981	\$ 37,981	\$ -	\$ 37,981	\$ -	Complete	100%
70	Canopy	\$ 12,000	\$ 11,994	\$ -	\$ 11,994	\$ -	\$ 11,994	\$ -	Complete	100%
72	Ponding: Upgrades: Rip rap and chainlink fence with slats.	\$ 38,000	\$ -	\$ 32,100	\$ 32,100	\$ -	\$ 32,100	\$ -	Complete	100%
74	ADA: Playground Equipment	\$ 12,000	\$ -	\$ 10,525	\$ 10,525		\$ 10,524	\$ 1	Complete	100%
75	Playground: Equipment	\$ 19,000	\$ 19,006	\$ -	\$ 19,006	\$ -	\$ 19,000	\$ 6	Complete	100%

24



Project Notes:

Major Activities:

The project is 100% Complete

Key Issues:

None at this time



Canutillo Middle School Complete

ID	PROJECT	PROPOSED PROJECT AMOUNT	BOND SERIES 2006	BOND SERIES 2011	PROJECT BUDGET	ENCUMBRANCES 04/30/2014	PROJECT EXPENSES TO DATE 04/30/2014	BUDGET BALANCE REMAINING	COMMENTS	% SPENT
141	Office Entrance Renovations	\$ 207,965	\$ 207,965	\$ -	\$ 207,965	\$ 8,081	\$ 197,198	\$ 2,686	Complete - Final Payment Pending	99%
140	Classrooms: Size Upgrade/Entrance & Office	\$ 355,000	\$ -	\$ 946,904	\$ 946,904	\$ 57,398	\$ 967,953	\$ (78,448)	Complete	108%
144	Site: Parking Lot / Ponding / Rip Rap / Xeriscaping Upgrades	\$ 600,000	\$ -	\$ 799,104	\$ 799,104	\$ 13,325	\$ 744,672	\$ 41,107	Complete - Final Payment Pending	95%
146	Renovation: Select Restroom Upgrades	\$ 113,297	\$ 113,297	\$ -	\$ 113,297	\$ 1,594	\$ 86,637	\$ 25,067	Complete - Final Payment Pending	78%
	Renovation: Select Restroom Upgrades	\$ 200,000	\$ -	\$ 22,629	\$ 22,629	\$ -	\$ 22,629	\$ 1	Complete - Final Payment Pending	100%
147	ADA: Compliance Issues: Elevator and Wheelchair Lift	\$ 81,745	\$ 81,745	\$ -	\$ 81,745	\$ 846	\$ 48,366	\$ 32,533	Complete - Final Payment Pending	60%
	ADA: Compliance Issues: Elevator and Wheelchair Lift	\$ 75,000	\$ -	\$ 13,602	\$ 13,602	\$ -	\$ 12,975	\$ 627	Complete - Final Payment Pending	95%
148	Site: Basketball / Play Courts	\$ 67,926	\$ 67,926	\$ -	\$ 67,926	\$ 1,200	\$ 35,020	\$ 31,707	Complete - Final Payment Pending	53%
	Site: Basketball / Play Courts	\$ 85,000	\$ -	\$ 11,837	\$ 11,837	\$ 111	\$ 8,354	\$ 3,372	Complete - Final Payment Pending	72%
149	Ceiling Tile: Replacements	\$ 77,000	\$ 76,486	\$ -	\$ 76,486	\$ 1,039	\$ 41,002	\$ 34,446	Complete - Final Payment Pending	55%
	Ceiling Tile: Replacements	\$ 65,000	\$ -	\$ 3,928	\$ 3,928	\$ -	\$ 5,612	\$ (1,684)	Complete - Final Payment Pending	143%
138	Lift Station: Upgrades	\$ 25,000	\$ -	\$ 20,300	\$ 20,300	\$ -	\$ 7,170	\$ 13,130	Pending	35%
142	Wetlands: Waste Water Removal	\$ 2,500,000	\$ -	\$ 1,921,234	\$ 1,921,234	\$ -	\$ 116,190	\$ 1,805,044	Pending	6%
135	Roofing: Upgrade Weight Room / Ag Building	\$ 130,000	\$ -	\$ 110,470	\$ 110,470	\$ -	\$ 110,470	\$ -	Complete	100%
136	Athletic Renovations	\$ 59,966	\$ 68,383	\$ -	\$ 68,383	\$ -	\$ 68,383	\$ 1	Complete	100%
137	Paint: Exterior Gym and Cafeteria	\$ 50,000	\$ -	\$ 25,034	\$ 25,034	\$ -	\$ 25,034	\$ -	Complete	100%
139	Abatement: Asbestos at Entry and Classrooms	\$ 65,000	\$ -	\$ 8,368	\$ 8,368	\$ -	\$ 8,788	\$ (420)	Complete	105%

Project Notes:

Major Activities:

The project is 100% Complete

Key Issues:

None at this time





Energy Management Johnson Control – Phase II

28



Water Conservation:	<u>100.00%</u> Complete
DDC Controls:	<u>100.00%</u> Complete
HVAC Upgrades:	<u>100.00%</u> Complete
Overall:	100.00% Complete

Canutillo High School Johnson Control - Project #108- Phase I



Water Conservation:	<u>100.00%</u> Complete
Lighting Upgrades:	<u>100.00%</u> Complete
DDC Controls:	<u>100.00%</u> Complete
HVAC Upgrades:	<u>100.00%</u> Complete
Overall:	100.00% Complete

2011 Budget:	\$ 25,000.00
Total Spent:	\$ 22,688.12
Percent Completion:	100%
Over/Under:	\$ 2,311.88 ↓
Contractor:	Ecoworks
SOW:	
Install 51 Ea. - 30W LED Wall Packs	



BILL CHILDRESS ELEMENTARY SCHOOL
ELECTRICAL: LIGHTING UPGRADE: EXTERIOR
PROJECT #20



2011 Budget:	\$ 141,942.61
Total Spent:	\$ 141,256.22
Percent Completion:	100%

Over/Under:	\$ 686.39 ↓
--------------------	-------------

Contractor:	Martinez Bros. Biohabitats
--------------------	-------------------------------

SOW:

Renovate Existing Wetlands: Rock for check dams, flow splitter basin, Liner, inlet and outlet piping, 3"-8" washed rock, 1/2"-1" gravel, 3/8" pea gravel



**BILL CHILDRESS ELEMENTARY SCHOOL
WETLANDS UPGRADES
PROJECT #29**



2011 Budget:	\$ 98,000.00
Total Spent:	\$ 116,200.00
Percent Completion:	100%
Over/Under:	\$ 18,200.00 ↑
Contractor:	Spectrum Floors

SOW:	New glazed porcelain floor tile 12"x12" Daltile "Color Scheme" and Vinyl Cove 4"
-------------	---



CANUTILLO ELEMENTARY SCHOOL
FLOORING: INTERIOR SLAB AND TILE REPLACEMENT
PROJECT #35





2011 Budget:	\$ 108,522.00
Total Spent:	\$ 84,871.49
Percent Completion:	100%

Over/Under:	\$ 23,650.51 ↓
--------------------	----------------

Contractor:	Exerplay
--------------------	----------

SOW:	New concrete slab, installation of SofTile on 4 Ea. Playgrounds, installation of Playground Equipment
-------------	---

CANUTILLO ELEMENTARY SCHOOL
NEW CANOPY, ADA-COMPLIANT PLAYGROUND AND FALL SURFACE
PROJECTS #49,50,51,52



2011 Budget:	\$ 25,000.00
Total Spent:	\$ 17,198.30
Percent Completion:	100%

Over/Under:	\$ 15,198.30 ↓
--------------------	----------------

Contractor:	Ecoworx
--------------------	---------

SOW:

New 41 Ea. – 30W Wall packs (Exterior)

New 9 Ea. – Canopy Lights

*Removal of old fixtures, install new led wall pack fixtures



DEANNA DAVENPORT ELEMENTARY SCHOOL
LIGHTING UPGRADE: EXTERIOR
PROJECT #53



Deanna Davenport Project #62



Concrete Slab: **100% Complete**

Playground Equipment
Installation: **100% Complete**

Softile Installation: **100% Complete**

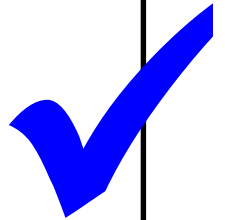



2011 Budget:	\$ 50,000.00
Total Spent:	\$ 49,975.00
Percent Completion:	100%
Over/Under:	\$ 25.00 ↓
Contractor:	International Quality Products

SOW:	
New	40'x46'10' Canopy
New	28'x30'x10' Canopy
New	38'x29'x8' Canopy
New	32'x26'x10' Canopy

GONZALO & SOFIA GARCIA ELEMENTARY SCHOOL

ADDITIONAL NEW CANOPIES

PROJECT #69,70



2011 Budget:	\$ 25,000.00
Total Spent:	\$ 17,756.59
Percent Completion:	100%
Over/Under:	\$ 7,243.41 ↓
Contractor:	Consolidated Electrical / Ecoworks
SOW:	
New 51 Ea. - 30W Exterior Wall packs (Consolidated Electrical)	
New 7 Ea. - Canopy Lights (Ecoworks)	



JOSE DAMIAN ELEMENTARY SCHOOL

ELECTRICAL: LIGHTING UPGRADE: EXTERIOR

PROJECT #76



Jose Damian Elementary Project #82



Concrete Slab: **100% Complete**

Playground Equipment
Installation: **100% Complete**

Softile Installation: **100% Complete**

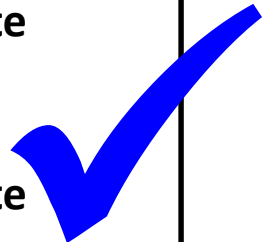

2011 Budget:	\$ 210,000.00
Total Spent:	\$ 146,677.48
Percent Completion:	100%

Over/Under:	\$ 63,322.52 ↓
--------------------	----------------

Contractor:	L.E.R Inc.
--------------------	------------

SOW:
Surveying, Engineering and testing, sunken area repairs and resurface, re-stripping, subsidence repairs



ALDERETE MIDDLE SCHOOL
FOOTBALL FIELD AND TRACK SUBSIDENCE REPAIRS AND STRIPING
PROJECT #121



ALDERETE MIDDLE SCHOOL

**ELECTRICAL: LIGHTING:
SAFETY LIGHTING FOR
FOOTBALL FIELD**



PROJECT #125

2011 Budget: \$ 30,000.00
Total Spent: \$ 0.00
Percent Completion: 100%

Over/Under: \$ 30,000.00 ↓

Contractor: El Paso Electric Company

FLOOD LIGHT

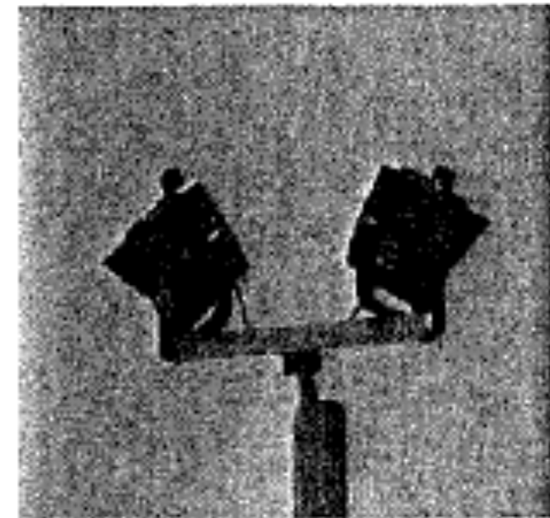

ALDERETE MIDDLE SCHOOL

PONDING UPGRADES AND RIP RAP

PROJECT #126



2011 Budget:	\$ 30,000.00
Total Spent:	\$ 23,322.00
Percent Completion:	100%

Over/Under:	\$ 6,678.00 ↓
-------------	---------------

Contractor:	High Ridge Construction
-------------	----------------------------

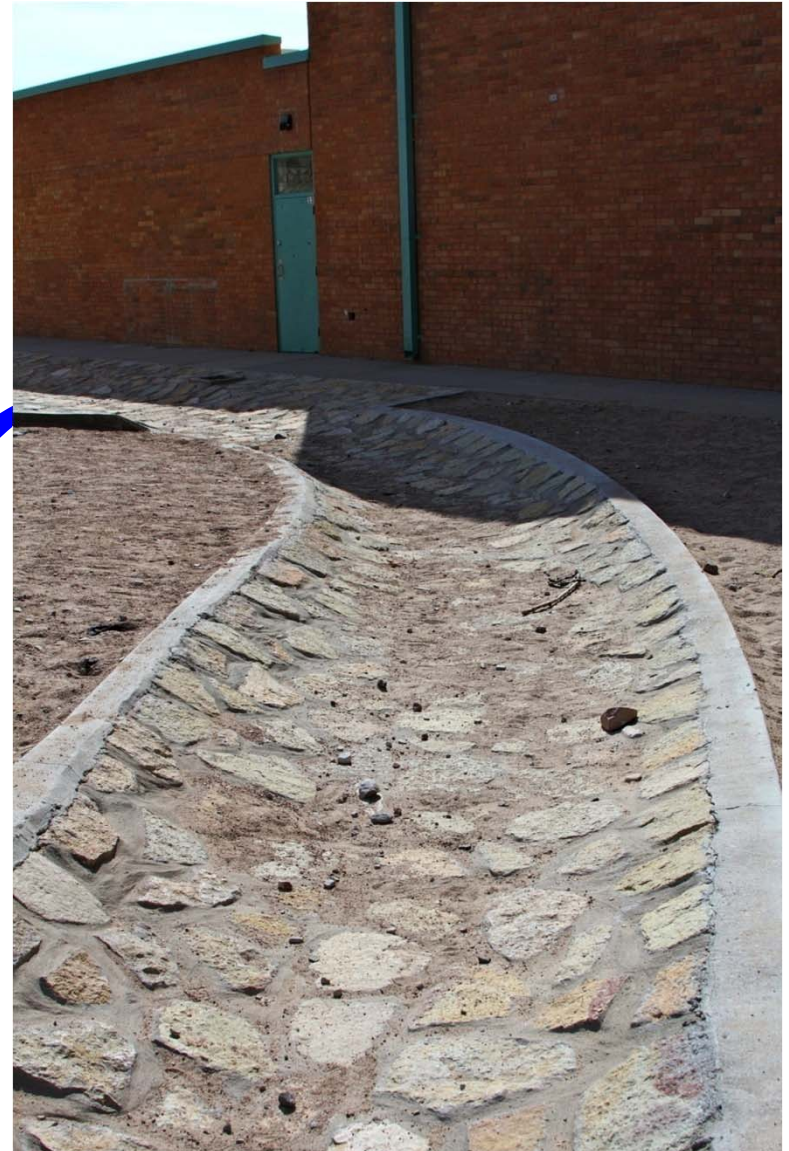

2011 Budget: \$ 130,000.00
Total Spent: \$ 110,470.07
Percent Completion: 100%

Over/Under: \$ 19,529.93 ↓

Contractor: Sams
Construction



CANUTILLO MIDDLE SCHOOL
ROOFING UPGRADE WEIGHT ROOM
PROJECT #135



2006 Budget: \$ 35,000.00
Total Spent: \$ 64,582.64
Percent Completion: 100%

Over/Under: \$ 29,582.64 ↑

Contractor: Martinez Irrigation
L.E.R Inc.



**CANUTILLO MIDDLE SCHOOL
ATHLETIC RENOVATIONS
PROJECT #136**



2011 Budget: \$ 50,000.00
Total Spent: \$ 25,033.61
Percent Completion: 100%

Over/Under: \$ 24,966.39 ↓

Contractor: Canutillo ISD



CANUTILLO MIDDLE SCHOOL
PAINT EXTERIOR GYM AND CAFETERIA
PROJECT #137



2011 Budget: \$ 17,000.00
Total Spent: \$ 204,231.88
Percent Completion: 100%
Over/Under: \$ 187,231.88 ↑
Contractor: L.E.R Inc.



CANUTILLO HIGH SCHOOL
TRACK RESURFACING AND STRIPING
PROJECT #105



CANUTILLO HIGH SCHOOL
FLOORING BAND ROOM
IMPROVEMENTS
PROJECT #109



2011 Budget:	\$ 15,000.00
Total Spent:	\$ 14,975.80
Percent Completion:	100%
Over/Under:	\$24.20 ↓
Contractor:	Spectrum Floors

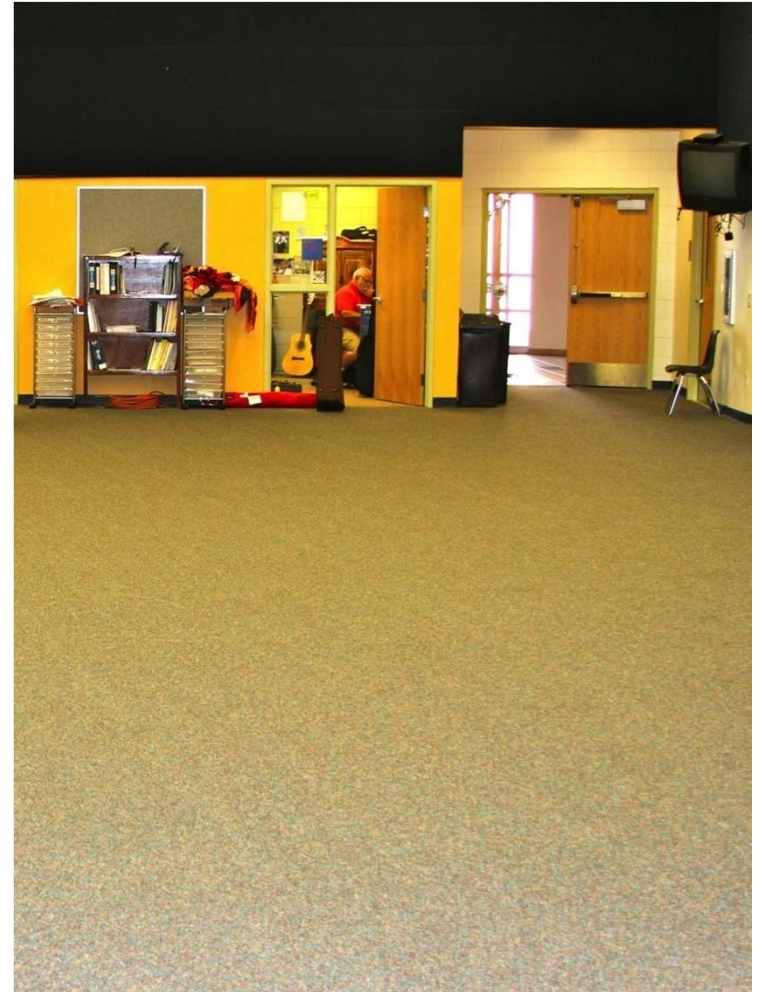

2011 Budget: \$ 417,200.00
Total Spent: \$ 417,199.44
Percent Completion: 100%

Contractor: US Track and Turf, Inc.



CANUTILLO HIGH SCHOOL
NEW FOOTBALL TURF
PROJECT #110



2006 Budget:	\$ 15,761.00
Total Spent:	\$ 15,737.11
Percent Completion:	100%
Over/Under:	\$ 23.89 ↓
Contractor:	Canutillo ISD

SOW:

Rebuild 3 – 1 ½ HP Taco Pumps
Rebuild 2 – 5 HP Taco Pumps



DISTRICT WIDE
BOILER PUMPS
PROJECT #8



2011 Budget: \$ 80,000.00
Total Spent: \$ 39,179.61

Over/Under: \$ 40,820.39 ↓

Percent Completion: 100%



**DISTRICT WIDE
MAINTENANCE EQUIPMENT
PROJECT #92**



2011 Budget:	\$ 1,000,000.00
Total Spent:	\$ 1,007,986.46
Over/Under:	\$ 7,986.40 ↑
Percent Completion:	100%

SOW:

New 2 Ea. 2012 Blue Bird School Buses
 New 8 Ea. 2012 Blue Bird Buses
 New 1 Ea. 2011 Chevrolet Microbird Bus
 New 1 Ea. 2012 Chevrolet Microbird Bus



DISTRICT WIDE
VEHICLES BUSES
PROJECT #93



2011 Budget:	\$ 100,000.00
Total Spent:	\$ 122,168.42
Over/Under:	\$ 22,168.42 ↑
Percent Completion:	100%
SOW:	
1 Ea. New F-250	
3 Ea. New F-150	
3 Ea. New E-150	



DISTRICT WIDE
VEHICLES: MAINTENANCE
PROJECT #94





Canutillo Middle School

SCOPE:

This project will consist of new construction of two classrooms and a multi-purpose room addition to be located between the 100 and 200 classroom wings at Canutillo Middle School.

- Project #139 Abatement: Asbestos at Entry
- Project #140 Classroom Size Upgrade
- Project #141 Entrance and offices renovation
- Project #144 Parking Lot/Ponding Upgrades
- Project #146 Select Restroom Upgrades
- Project #147 ADA: Compliance Issues:
Elevator and Wheelchair Lift
- Project #148 Basketball / Playground Courts
- Project #149 Ceiling Tile Replacements

DESIGN STATUS:

Design Development – 100% Complete ✓
Construction Documents – 100% Complete ✓

A/E: MNK Architects

Contractor: BYERS





As seen on the agenda: Discussion and possible action regarding Banes General Contractors Owner's Contingency Change Request # 1.

Attachments: CHS, CCR # 1



Canutillo Independent School District

7965 Artcraft Rd.
El Paso, Texas 79932

Mailing Address: PO Box 100
Canutillo, Texas 79835

Dominic Padilla

Executive Director of Facilities and Transportation

(915) 727-1555

dpadilla@canutillo-isd.org

MEMORANDUM

To: Members of the Board of Trustees

FROM: Dominic Padilla, Executive Director of Facilities and Transportation

DATE: August 29, 2014

RECOMMENDATION: Administration recommends the approval of the Owner's Contingency Change Request #1 for the installation of a new Storm Sewer manhole added to original drawings per Owner's Contingency Change Request # 1 in the amount of \$5,217.55

RATIONALE: In accordance with CV (Local) Change orders in excess of \$5,000 shall be reported to the Board for approval prior to the implementation of the change order.

Additionally, "Owner's Board of Trustees shall designate one or more authorized representatives to act on its behalf in the day-to-day administration of the Project, to issue stop work orders, and to authorize expenditures within Owner's contingency, subject to a limit of \$5,000 for any additional costs, expenses or changes in the Owner's contingency and/or Construction contingency.

PURCHASING SUMMARY: Banes Contingency Change Request #1

Department: Facilities & Transportation

Award to: Banes General Contractors, Inc.

Funding Source: Owner's Contingency Fund

Procurement Type: Owner's Contingency Change Request

Contract Term: N/A

Amount: \$5,217.55



3560 Lee Blvd. • El Paso, Texas 79936 • Tel (915) 857-2733 • Fax (915) 857-3187

4/3/2014

ATTN: RUSSELL LETZ - BANES GENERAL CONTRACTORS, INC.

RE: CANUTILLO HS IMPROVEMENTS CHANGE ORDER No 1 (REVISED)

DESCRIPTION OF CHANGE

NEW ADDITIONAL 48" MANHOLE

COST BREAKDOWN

MATERIALS: MANHOLE, CONCRETE AND ADJUSTING RINGS, ATTACHED QUOTE	\$2,720.00
RENTS: MAN GUARD	\$715.00
LABOR	\$376.00
EQUIPMENT	\$726.00
 TOTAL COST	 \$4,537.00
OVERHEAD & PROFIT 15%	\$680.55
	\$5,217.55

CHANGE ORDER IS BASED ON GRADING PLAN - 1 SHEET C-01.0 PER CITY COMMENTS
 REVISION DATED 2-25-2014 SUGR13-00247, WHICH SHOWS THIS NEW MANHOLE.

TOTAL PRICE FOR CHANGE ORDER \$5,217.55

STANDARD EXCLUSIONS: ANY WORK NOT LISTED ABOVE, PERMITS, TESTING, FILTER FABRIC, DRILLED PIERS, HERBICIDE, ANY FEES, PESTICIDE, BONDS, UTILITY WORK, CONSTRUCTION ENTRANCE, TERMITE CONTROL, COMPOST, FERTILIZER, VAPOR BARRIER, TRAFFIC CONTROL, LANDSCAPE GRADING, TREE WOUND PAINT, EROSION CONTROL, POLLUTION CONTROL, DUST CONTROL ONCE WE ARE AWAY FROM JOBSITE, REMOVAL OF TRASH AND UNFORESEEN UNDERGROUND ITEMS, SPOTTING EXISTING UTILITIES, HAND TRENCH AND/OR STRUCTURAL EXCAVATION AND BACKFILL, TOP SOIL, TRENCH PATCH, IF NEEDED USE CALL FOR PRICE. (MIN. 9 SY), CHAIN LINK FENCE, PATCH WORK, WATER TO BE PROVIDED BY OTHERS, STRUCTURAL CONCRETE, REINFORCING STEEL, EMBEDDED ITEMS, SITE CONCRETE, DEWATERING, ETC. PRICE INCLUDES 3 MOBILIZATIONS MAX.

JOE GALLEGOS
 VICE-PRESIDENT



9101 Roseway
 P.O. Box 17961
 El Paso, TX 79917-7961
 Office: (915) 859-9362
 Fax: (915) 850-4215

PROPOSAL GOOD FOR 30 DAYS

"Quality Products and Service Since 1946"
 Visit us at our website @ www.westernprecast.com

TO: All Bidders
 Page 1 of 1
 REV 10.02.14

JOB# CISD Canutillo HS Improv.
 Location: Canutillo, TX.
 Date: July 25, 2013 (Revised)
 ADDED 11.18.2013 KEC

3/21/2014	F.O.B.: SEE BELOW	TERMS: NET/30 ON APPROVED CREDIT	SHIPPING DATE: NEGOTIATED	
QUANTITY	ITEM	UNIT	PRICE	TOTAL
1 EA	<u>FREIGHT/DELIVERY:</u> FREIGHT TO WPC/ DELIVERY TO JOBSITE		\$530.00 EA	\$530.00
1 EA	<u>48" I.D. STORM SEWER MANHOLE:</u> 48" DIA. MANHOLE WITH 5" THK. WALLS, PER C-470 SPECIFICATIONS			
11 VF	AND DRAWINGS, 11'-0" TOTAL VERTICAL FEET @ \$77.00/VF.		\$77.00 VF	\$840.00
1 EA	8" THICK X 70" DIAMETER SHELF FOR MONOLITHIC BASE		\$380.00 EA	\$380.00
1 EA	PRECAST MANHOLE INVERT		\$300.00 EA	\$300.00
1 EA	30" DIA. CAST IRON RING & COVER H-20 LOADING (EJCO 2014)		\$380.00 EA	\$380.00
1 EA	PRESS SEAL GASKET 1208 (FOR 8" DIA. PVC NOT INCLUDED)		\$80.00 EA	\$80.00
1 EA	PRESS SEAL GASKET 16M (FOR 12" DIA. PVC NOT INCLUDED)		\$120.00 EA	\$120.00
1 EA	BOX OF CONSEAL SEALANT (8 ROLLS - 112' PER BOX)		\$90.00 EA	\$90.00
<u>WE EXCLUDE:</u> ANY ITEM NOT SPECIFICALLY LISTED ON QUOTE ANY INTERIOR/EXTERIOR COATING OR SEALANT FOR ALL ITEMS				
<p>* Items not specifically listed are to be considered excluded from quote. Terms: Net thirty from delivery date. Payment not contingent on funding from owner to contractor; no sales tax included in this quote; <u>Bidding:</u> Western Precast takes plans off as a courtesy to the contractor. The contractor is responsible for final quantities and take-offs. Unit pricing always prevails. PROPOSAL # 13-0236; ABOVE PRICES GOOD FOR 30 DAYS</p>				
			TOTAL	\$2,720.00

Prepared by:
 Lorenzo Pacheco Jr. ext.12

EL PASO OWNED AND OPERATED

Approved by:
 JOHN FRANKLIN

Edgar Goytia-Chavez

From: John Panahi <john@banes-gc.com>
Sent: Friday, October 03, 2014 10:13 AM
To: Edgar Goytia-Chavez
Cc: Misael Luns
Subject: CHS CCR #1
Attachments: CHS CCR 1 (Revised).pdf

Edgar,

Apologize for the confusion, attached is the modified back up that removes the items that were not applicable (*i.e. trench drain. Rings and additional local delivery fee*). In addition, some items were rounded down (*i.e. \$847 to \$840*) to simplify the math I assume.

John Panahi
Vice President

Banes General Contractors, Inc.

6001 Doniphan Dr.
El Paso, TX 79932
(915) 584-0404 Office
(915) 383-3293 Cell
(915) 584-2432 Fax

As seen on the agenda: Discussion and possible action regarding Banes General Contractors Contractor's Contingency Change Request #2.

Attachments: CHS Contractor CCR #2



Canutillo Independent School District

7965 Artcraft Rd.
El Paso, Texas 79932

Mailing Address: PO Box 100
Canutillo, Texas 79835

Dominic Padilla

Executive Director of Facilities and Transportation

(915) 727-1555

dpadilla@canutillo-isd.org

MEMORANDUM

To: Members of the Board of Trustees

FROM: Dominic Padilla, Executive Director of Facilities and Transportation

DATE: August 29, 2014

RECOMMENDATION: Administration recommends the approval of the Contractor's Contingency Change Request #2 for the relocation of existing Information Technology lines that were in conflict with the new Gymnasium Building per Contractor's Contingency Change Request #2 in the amount of \$39,005.30

RATIONALE: In accordance with CV (Local) Change orders in excess of \$5,000 shall be reported to the Board for approval prior to the implementation of the change order.

Additionally, "Owner's Board of Trustees shall designate one or more authorized representatives to act on its behalf in the day-to-day administration of the Project, to issue stop work orders, and to authorize expenditures within Owner's contingency, subject to a limit of \$5,000 for any additional costs, expenses or changes in the Owner's contingency and/or Construction contingency.

PURCHASING SUMMARY: Banes Contractor Contingency Change Request #2

Department: Facilities & Transportation

Award to: Banes General Contractors, Inc.

Funding Source: Contractor's Contingency Fund

Procurement Type: Contractor's Contingency Change Request

Contract Term: N/A

Amount: \$39,005.30

CONTINGENCY CHANGE REQUEST

Copies to:

- Owner
- Architect
- Contractor
- Field
- Other

CONTINGENCY CHANGE REQUEST

PROJECT: Canutillo High School Improvements
6675 S. Desert Blvd.
El Paso, TX 79932

REQUEST No.: 002

Date: 6/04/14

Owner: Canutillo Independent School District

Project No. CISD Bond Project #107

CM @ Risk / General Contractor:

Architect / Consultant:

Banes General Contractors, Inc.

Philo Wilke Partnership

Please submit an itemized quotation for changes in the Contract Sum and /or Time incidental to proposed modification to the Contract Documents described herein.

THIS IS NOT A CHANGE ORDER NOR A DIRECTION TO PROCEED WITH WORK DESCRIBED HEREIN.

Description: (Written description of the work)

Relocation of IT lines around construction site new gymnasium.

Attachments: GarCom Proposal dated 5/17/14

Response by Contractor:

Add to Contract Sum by Change Order

\$ _____

Deduct from Construction Managers Contingency

\$39,005.30

Attachments: Estimate and supplier proposal

Architect / Consultant Recommendation Letter

Additional days requested for this CCR: 0

Initial Approval

Review By:  _____

Architect/Consultant

Bond Project Mgr.

Bond Supt.

Date

Approved By: _____
CISD Director of Facilities

Date



May 17, 2014

Banes General Contractors, Inc.
ATTN: Mr. Russell Letz

Project: Canutillo HS Improvements, El Paso, TX

Proposal: Communications Proposal under Telecommunications System as noted for ISP and OSP Cabling Portion Specifications only. No other specs provided for communications section under this effort.

Proposal Prepared by: Jesse A. Garcia, RCDD

 Appreciates the opportunity to submit a proposal for your review and approval for the telecommunications cable installation for above reference project as an SBA Certified HUBZone, SDB, DBE, Minority Owned Company. Price being submitted by GarCom, Inc. is based on design narratives provided. The project will be overseen by Jesse Garcia, RCDD #151461R.

 **SCOPE OF WORK:**

Provide a complete Structured Cabling Systems for a complete communications system for above referenced project under Updated Programming Narrative and Industry Standards.

- 12 Strand Fiber Systimax Lazerspeed; approximately 1000ftx2=2000lf
- 50 pair OSP rated PE-89 Copper Cable; approximately 1000ftx2=2000lf
- RG6 Coax Cable; approximately 1000lf
- 3-4"PVC/2-2"PVC Ductbank System Non-Concrete Encased
- 1-24"X48" Open Handhole – See Option Below
- Saw-Cut and Replace Approximately 12" Thick slab; Approx. 60lf
- Utilize Existing Panels, BEP's, Facility Comm Room Connectivity Devices
- 1-3" 3 Cell Maxcell in one 4" Ductbank
- Length of Ductbank System:
 1. 2-2"PVC - 160lf
 2. 3-4"PVC – 60lf
- Open Handhole Option on proposal has been provided based on emailed Hubbell Handhole. GarCom suggests substitution as the Hubbell handhole has a 24 week lead time. Duravault Handhole has a 2 week lead time. Duravault provides two options:
 1. 30x48x18
 2. 30x48x24 (recommended for Conduit coming in from bottom of open Handhole)
- 2-10' 3/4" Ground rod inserted in each Handhole. Ground rods will be available for items to be grounded.

 **EXCLUSIONS:**

The following items are excluded from GarCom proposed solution.

- Installation of all EMT conduit, cable tray system, grounding, back boards, switch, and H-Vac unit.
- All required 120VAC shall be provided by the electrical contractor.
- Cabling and Equipment: A/V System/Card Access/Security/CCTV/Nurse Call/Mass Notification/Paging-Speaker System
- Fiber Optic requirements for systems for interconnectivity other than Communications Fiber Backbone
- Phone Systems/Critical Systems UPS/Communications Network Equipment/Wifi/WAP/CATV Equipment
- Telephone Closet Wall Boxes/Cabinets/Rack systems where Noted
- Main Grounding TMGB/TGB and backbone grounding
- Permits/Locates/ Project Bonding
- Taxes

GarCom Project Terms:

- All required conduit and raceways (including basket tray) will be provided by the electrical contractor, equipped with pull lines and 100% completed prior to the installation of system devices.
- GarCom, Inc. is in the understanding that adequate conduit sizing has been specified and installed.
- Any additional material and labor requested that is not included in the scope of work, to include a preliminary design with proposed routes, will constitute a change order.
- All change orders must be in writing, signed by both Persons of Authority between Contractor, and GarCom, Inc. before any materials are ordered or labor is scheduled.
- Price quoted includes working during normal. Any Delays caused by others will be charged accordingly to include any overtime against the project.
- GarCom, Inc. shall request a scope of work review and submittal authorization to ensure the accuracy of this proposal prior to entering into contract.
- All testing for, identification, and work with hazardous materials, shall be by the Owner. All costs for permits are to be provided by others.
- GarCom, Inc. will comply with all safety standards and policies.

GarCom Proposal Attachments:

- 2014-1355 Comm Ductbank Conduit System Non-Concrete Encased

GarCom QUALIFICATIONS:

- Bonding capabilities: \$15mil per project / \$20mil aggregate
- BICSI Certified Corporation
- BICSI Certified Installers, Technicians, and Registered Communications Distribution Designer (RCDD)
- Certified Fluke DTX 1800 Copper / Fiber Testing
- Certified Corning / Light Brigade Fiber Optic Splicing / Termination / Testing
- Certified Uniprise / Systimax / Leviton / Panduit / Hubbell / Holocom / Corning
- 3M Certified Copper / Fiber Solutions
- I3A / I3MP / ISEC / Range System Compliant Contractor

GarCom Project Proposal Amount: \$39,005.30

- Non-CE Ductbank Option: 2014-1355 \$39,005.30

PROPOSAL ESTIMATE

6/3/2014



1008 Diesel Drive
 El Paso, Texas 79907
 Submitted by: Jesse Garcia, RCDD
 Ph.: (915) 859-2424 Fax: (915) 775-0222

Company: Banes General Contractors, Inc.
 Attention: Mr. Russell Letz
 email: russell@banes-gc.com
 City-State:
 PHONE: 915.525.5061 Fax:
 PHONE:

Date: 6/3/2014

QUOTE No. 2014-1355

Project: Canutillo HS Improvements
Proposal: OSP Copper/Fiber Installation Infrastructure -Commscope/Uniprise/Corning Certified
Site Loc.: Fort Bliss, TX

Quotation Valid
Until 30 Days

<u>ITEM NO.</u>	<u>QTY</u>	<u>DESCRIPTION</u>	<u>MFG</u>	<u>MODEL</u>	<u>UNIT</u>	<u>EXTENDED</u>	
1	1	OSP Infrastructure See Notes & Entire Proposal Documents	GarCom	Material/Labor	\$ 36,282.05	\$ 36,282.05	
2	2	Ground Rod Per Hand Hole See Notes & Entire Proposal Documents	GarCom	Material/Labor	\$ 250.00	\$ 500.00	
3	1	Option for provided Spec Handhole-Each Price Difference deducted from Item No. 1. Labor already included in Item 1	DuraVault	Material	\$ 1,573.25	\$ 1,573.25	
4	1	Shipping of Handhole - Each 2 week lead time	Shipping	Shipping	\$ 500.00	\$ 500.00	
5	6	Employee Background Check Fee	CHS		\$ 25.00	\$ 150.00	
5		Proposed cable system Installed per EIA/TIA and I3A Guideline Specifications: Per Supplied Drawings					
6		1) OSP Ductbank Infrastructure per site survey performed on 05/06/2014					
7		2) Includes Backbone Fiber/Copper/MaxCell in new Ductbank					
8		3) See Entire Proposal Documents for Inclusions and Exclusions to Project					
9		Exclude					
10		a) Cable Tray/EMT system/Grounding of EMT and Cable Tray System					
11		b) AV System/Card Access Systems/Security/Cameras					
12		c) OSP ductbank Concrete Encasement					
13		d) Ladder Trays for Cabling for entire facility					
14		e) Plywood Termination Boards					
15		f) CATV Cabling Headend Equipment/Amplifiers/Taps/Feed/Service					
16		g) Network Equipment/UPS/Patch Cable OFOI/Telephones/Telephone System/Service Provider Signal					
17		h) Main Grounding TMGB and backbone Grounding					
18		i) Permits/Locates/Project Bonding/Taxes					
19		j) See Entire Proposal Documents for Inclusions and Exclusions to Project					
20		TOTAL MATERIAL/Labor			\$	39,005.30	

LABOR DETAIL

<u>QTY</u>	<u>LABOR TYPE</u>	<u>UNIT PRICE</u>	<u>EXTENDED PRICE</u>
21	0.00 Bonding	\$	-
		\$	-
		\$	-
22	TOTAL PROJECT COST:	\$	39,005.30

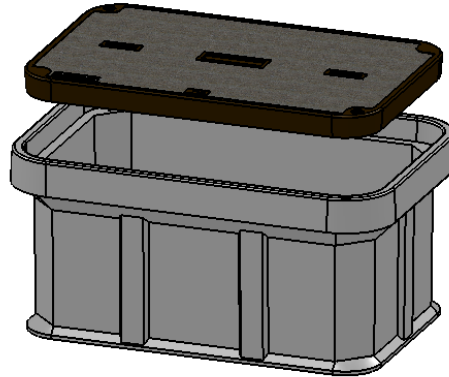
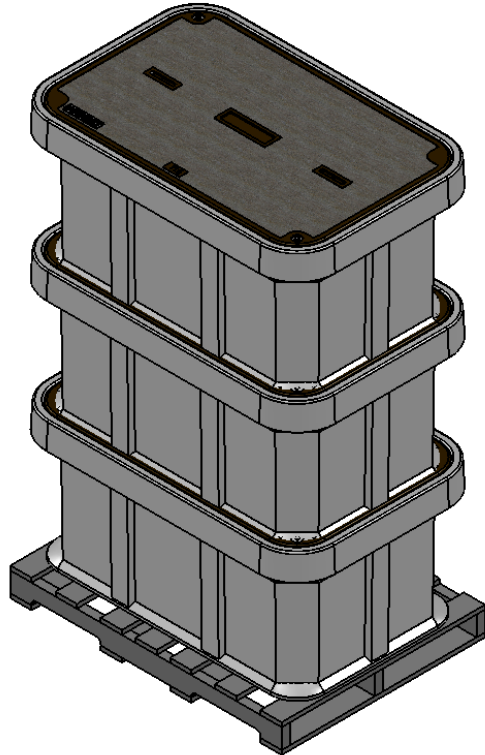
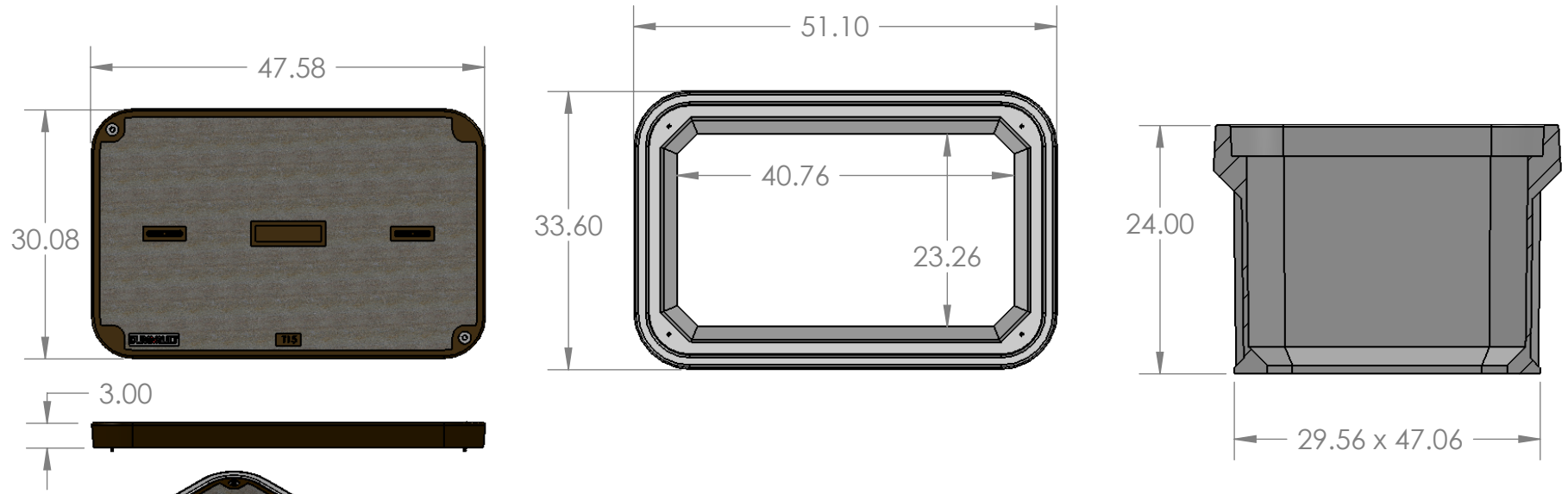

PRODUCT FEATURES

- POLYMER CONCRETE COVER
- POLYMER CONCRETE BODY
- TIER 8,15,22 LOAD RATINGS AVAILABLE
- 2 HEX HEAD BOLTS ARE STANDARD
- PRODUCT CONFORMS TO STANDARDS, **ANSI/SCTE77 2010** AND **WUC 3.6**

PROPRIETARY AND CONFIDENTIAL
 THE INFORMATION CONTAINED IN THIS DRAWING IS THE SOLE PROPERTY OF DURAVULT LLC. ANY REPRODUCTION IN PART OR AS A WHOLE WITHOUT THE WRITTEN PERMISSION OF DURAVULT IS PROHIBITED.

UNLESS OTHERWISE SPECIFIED:		NAME	DATE
DIMENSIONS ARE IN INCHES TOLERANCES: +/- 1/8" FRACTIONAL ± ANGULAR: MACH ± BEND ± TWO PLACE DECIMAL ± THREE PLACE DECIMAL ±	DRAWN	jlm	05/11/12
	CHECKED		
	ENG APPR.		
	MFG APPR.		
INTERPRET GEOMETRIC TOLERANCING PER:	Q.A.		
MATERIAL Polymer Concrete	COMMENTS: BOX WEIGHT = 326 lbs. COVER WEIGHT = 203 lbs.		
FINISH			
DO NOT SCALE DRAWING			



POLYMER CONCRETE HANDHOLE
 A - TIER 8 - 12000 LBS
 B - TIER 15 - 22,500 LBS
 C - TIER 22 - 33800 LBS
 ST- STRAIGHT

SIZE A	DWG. NO. PC304824STB	REV A
SCALE: NTS	DRAWING NO.	012858



May 27, 2014

Banes General Contractors, INC.
Ref: Canutillo HS Improvements – Ductbank Installation/Repair

Dear Sir or Madam:

GarCom, Inc. has received and is in agreement with the architect, Gonzalo Aguilar Engineering's Typical Trench Details and it meets specifications and construction details as per construction documents provided on 05/21/2014.

Sincerely,



Jesse A. Garcia, RCDD
President
GarCom, Inc.

As seen on the agenda: Discussion and possible action regarding Banes General Contractors Owner's Contingency Change Request #4.

Attachments: CHS, CCR #4



Canutillo Independent School District

7965 Artcraft Rd.
El Paso, Texas 79932

Mailing Address: PO Box 100
Canutillo, Texas 79835

Dominic Padilla

Executive Director of Facilities and Transportation

(915) 727-1555

dpadilla@canutillo-isd.org

MEMORANDUM

To: Members of the Board of Trustees

FROM: Dominic Padilla, Executive Director of Facilities and Transportation

DATE: August 29, 2014

RECOMMENDATION: Administration recommends the approval of the Owner's Contingency Change Request #4 to provide additional construction materials testing services per Owner's Contingency Change Request #4 in the amount of \$5,370.50

RATIONALE: In accordance with CV (Local) Change orders in excess of \$5,000 shall be reported to the Board for approval prior to the implementation of the change order.

Additionally, "Owner's Board of Trustees shall designate one or more authorized representatives to act on its behalf in the day-to-day administration of the Project, to issue stop work orders, and to authorize expenditures within Owner's contingency, subject to a limit of \$5,000 for any additional costs, expenses or changes in the Owner's contingency and/or Construction contingency.

PURCHASING SUMMARY: Banes Contingency Change Request #4

Department: Facilities & Transportation

Award to: Banes General Contractors, Inc.

Funding Source: Owner's Contingency Fund

Procurement Type: Owner's Contingency Change Request

Contract Term: N/A

Amount: \$5,370.50

CONTINGENCY CHANGE REQUEST

Copies to:

- Owner
- Architect
- Contractor
- Field
- Other

CONTINGENCY CHANGE REQUEST

PROJECT: Canutillo HS Improvements
6675 S. Desert Blvd.

REQUEST No.: 004

Date: August 27, 2014

Owner: Canutillo Independent School District

Project No: CISD Bond Project #107

CM @ Risk / General Contractor:

Architect /Consultant:

Banes General Contractors, Inc.

Philo Wilke Partnership

Please submit an itemized quotation for changes in the Contract Sum and /or Time incidental to proposed modification to the Contract Documents described herein.

THIS IS NOT A CHANGE ORDER NOR A DIRECTION TO PROCEED WITH WORK DESCRIBED HEREIN.

Description: (Written description of the work)

Materials Testing, Budget Increase

Attachments: ENCON International, Inc. Quantity Estimate Cost Summary, dated 6/4/13

Response by Contractor:

- Add to Contract Sum by Change Order
- Deduct from Owners Contingency
- Attachments: Estimate and supplier proposal
- Architect / Consultant Recommendation Letter

\$ _____

\$ 5,370.50

Additional days requested for this CCR: TBD

Initial Approval

Review By:  _____
Architect/Consultant Bond Project Mgr. Bond Supt. Date

Approved By: _____
CISD Director of Facilities Date

CONSTRUCTION MATERIALS TESTING
Qty Estimate Cost Summary Sheet For
CANUTILLO ISD
Canutillo H.S.
ENCON Proposal No. 426-13

	Qty	Unit	Unit Price	Cost
<u>SOILS FIELD/LABORATORY TESTING</u>				
1. Field Technician I Time Travel (Portal to Portal)	7.5	Hour	\$42.00	\$315.00
2. Field Technician I Testing on Site	15	Hour	\$42.00	\$630.00
3. Vehicle / Mileage (Per Day)	15	Each	\$35.00	\$525.00
4. Use of Density Gauge	15	Per Day	\$30.00	\$450.00
5. Density Testing	45	Per Test	\$10.00	\$450.00
4. Moisture / Density Relationship (Proctor)	5	Each	\$150.00	\$750.00
5. Sieve Analysis	5	Each	\$55.00	\$275.00
6. Plasticity Index	5	Each	\$50.00	\$250.00
7. Sandcone Density Testing	0	Each	\$25.00	\$0.00
			Sub-Total	\$3,645.00
<u>CONCRETE FIELD/LABORATORY TESTING</u>				
1. Field Technician I Travel Time (Portal to Portal)	10	Hour	\$42.00	\$420.00
2. Field Technician I Testing on Site	20	Hour	\$42.00	\$840.00
3. Vehicle / Mileage (Per Day)	20	Each	\$35.00	\$700.00
4. Concrete Field Testing Equipment	10	Per Day	\$30.00	\$300.00
5. Compressive Strength (per set of 4 specimen)	10	Per Set	\$80.00	\$800.00
6. Strength of Mortar (per set of 3 specimen)	10	Per Set	\$60.00	\$600.00
7. Strength of Grout (per set of 4 specimen)	10	Per Set	\$100.00	\$1,000.00
			Sub-Total	\$4,660.00
<u>SPECIAL INSPECTION FIELD TESTING SERVICES (STEEL) *</u>				
1. Field Inspector Travel Time (Portal to Portal)	2.5	Hour	\$90.00	\$225.00
2. Field Inspector Testing on Site (minimum 4-hour per trip)	20	Hour	\$90.00	\$1,800.00
3. Vehicle / Mileage (Per Day)	5	Each	\$35.00	\$175.00
			Sub-Total	\$2,200.00
<u>PROJECT ADMINISTRATION</u>				
1. Admin Report Preparation / P.E. Review and Stamp Reports	42	Each	\$25.00	\$1,050.00
2. Project Management Technical Planning/QC	3	Hour	\$95.00	\$285.00
3. Principal Engineer Technical Planning/QC	1	Hour	\$110.00	\$110.00
			Sub-Total	\$1,445.00
<u>CONTINGENCY FEE (15%)</u>				
1. 15% Contingency Fee	1	Lump Sum	\$1,792.50	\$1,792.50
			Sub-Total	\$1,792.50
			Estimate Total	\$13,742.50
			Executed Proposal	\$8,372.00
			Total to add	\$5,370.50
			Not to Exceed Amount	\$13,742.50

Submitted by: _____ Date: 9/30/2014

Jesus O Corrales
Project Manager

Any standby time (on-site time) during the regular working hours will be charged at Technician's regular hourly rates of \$42.00/hr. A minimum charge of 1 (one) hour will be billed for technician on-site time. Additional testing or professional services will be quoted upon written request. Services requested and performed outside the regular working hours on Saturdays and Sundays will be billed 1.5 times the listed unit fees. Additional testing services or professional fees will be quoted upon request. Any local, state, or federal taxes are the Client's responsibility and will be added to the invoice amount as appropriate. Only work performed in the items stated above will be invoiced.

*** SPECIAL INSPECTION (STEEL INSPECTOR) SERVICES SHOWN ABOVE INCLUDE VISUAL INSPECTIONS, BOLT TORQUE INSPECTIONS, AND WELDING INSPECTIONS.**

ENCON International, Inc. considers the information contained on this schedule to be proprietary. This schedule and any information contained herein shall not be disclosed and shall not be duplicated or used in whole or in part for any purposes other than to evaluate our proposal.

El Paso Office: 7307 Rainbow Circle, Suite 103, El Paso, Texas 79912 • Fax 915-581-2049 • Phone 915-833-3740

As seen on the agenda: Discussion and possible action regarding Reyes Change Order Proposal #2

Attachments: Reyes, Change Order Proposal #2



Canutillo Independent School District

7965 Artcraft Rd.
El Paso, Texas 79932

Mailing Address: PO Box 100
Canutillo, Texas 79835

Dominic Padilla

Executive Director of Facilities and Transportation

(915) 727-1555

dpadilla@canutillo-isd.org

MEMORANDUM

To: Members of the Board of Trustees

FROM: Dominic Padilla, Executive Director of Facilities and Transportation

DATE: September 30, 2014

RECOMMENDATION: Administration concurs with the recommendation of the Architect of Record regarding Change Order Proposals 14, 15, 21 and 22. We recommend these change orders be accepted.

RATIONALE: In accordance with CV (Local) Change orders in excess of \$5,000 shall be reported to the Board for approval prior to the implementation of the change order. Additionally, "Owner's Board of Trustees shall designate one or more authorized representatives to act on its behalf in the day-to-day administration of the Project, to issue stop work orders, and to authorize expenditures within Owner's contingency, subject to a limit of \$5,000 for any additional costs, expenses or changes in the Owner's contingency and/or Construction contingency.

Please note Change Order Proposals 16, 17, 18, 19 have been previously approved by Administration in accordance with CV (Local) as the dollar amount fall between \$500 and \$5,000 limits.

PURCHASING SUMMARY:

Owner Contingency for Change Order 14, 21 and 22

Contractor Contingency for Changer Order 15

Department: Facilities & Transportation

Award to: VEMAC

Funding Source: Contingency Funds

Procurement Type: Contingency Change Request

Contract Term: N/A

Amount: \$30,727.00

Reyes Elementary School - CISD

VEMAC, INC. 7440 Northern Pass
 915-566-1911 El Paso, TX 79911

Date: 09/30/14

Contract No. 282

Approved Time Extensions

	NTP	GMP Time	Comp Date	Time Ext	Rev Comp.	Pending	Projected Completion
Orig Schedule	02/26/14	489	06/30/15	0	06/30/15	0	06/30/15
Weather day - high winds email			04/30/14	1			07/01/15

Approved Change Log

Owner Contingency							Amount	363,846
CO#	Received	Submitted	Review	Approved	PCO#	Description	Amount	Time
01				07/29/14	01 to 11	Misc credits	182,332	
Revised Owner Contingency							546,178	

Proposed Change Log

Revised Owner Contingency							CDA		Amount	546,178	
PCO#	Received	Submitted	Review	Approved	CO#	Description	Date	Yes/No	Amount	Time	
12	06/20/14	08/27/14	34			Stage - Back & Side Curtains	09/16/14	No	12,992		
13	08/21/14	08/27/14	34			Window XXII - Curtain Wall	09/16/14	No	9,381		
14	08/22/14	08/27/14	34			Laminated vision glass at doors A & G	09/16/14	Yes	8,117		
16	04/30/14	09/05/14	25			Electrical permit set revisions	09/16/14	Yes	3,897		
17	07/15/14	09/05/14	25			Kitchen - add 2 floor sinks	09/16/14	Yes	4,140		
18	08/11/14	09/05/14	25			RFI 86 - Kitchen - Water heater booster / misc elec	09/16/14	Yes	2,630		
19	08/13/14	09/17/14	13			RFI 82 - Concession / Footbal Conduits	09/23/14	Yes	4,978		
20	09/12/14	09/30/14	0			RFI 88 - Parkway Landscape			17,888		
21	09/30/14	09/30/14	0			RFI 95 - Service yard stem wall	10/02/14	Yes	7,054		
22	04/30/14	09/30/14	0			Permit set revisions - Bus Drop Off	10/02/14	Yes	5,287		
22											
23											
24											
25											
26											
27											
28											
29											
30											
31											
32											
33											
34											
35											
36											
									Cost Proposal Pending	76,364	
									Projected Owner Contingency	469,814	0

Proposed Change Contractor Contingency							CDA		Amount	
PCO#	Received	Submitted	Review	Approved	CO#	Description	Date	Yes/No	Amount	Time
15		09/29/14	1			Rigid Insulation - Area B, C & F	09/29/14	Yes	10,269	



MEMORANDUM # 14

TO: Canutillo Independent School District

ATTN: Mr. Edgar Goytia-Chavez

CC: Juan Contreras

FROM: Hugo Saldaña, AIA

DATE: Septiembre 16, 2014

SUBJECT: Silvestre & Carolina Reyes School

RE: Proposal Request # 14

Attached is correspondence from VeMac requesting action concerning Proposal Request # 14. CISD has requested that CDA makes recommendation on PCO # 14 and the following is our recommendations:

14- CISD requested to replace the 1/4 vision glass at all classroom doors with a laminate glass.
Total proposal for this work is \$8,117.00

CDA has reviewed the proposal and the breakdowns provided by the affected subcontractors. The proposal appears to be appropriate for the scope of work required. We recommend acceptance.



VENEGAS ENGINEERING MANAGEMENT & CONSTRUCTION

Date: 08/27/14

Project : **CISD Silvestre and Carolina Reyes School**
 Project Contract No. : 282
 Location : 7440 Northern Pass, El Paso, TX 79911

PC No. 14

Proposed Change: Laminated Glass at Door Vision Panels

DESCRIPTION	SUB	QTY.	UNIT	MATERIAL		LABOR		OVERHEAD & PROFIT		SUBTOTAL	
				Unit \$	TOTAL	Unit \$	TOTAL	%	TOTAL	Unit \$	TOTAL
Laminated Glass	Nano's Glass	109	EA	59.81	6,519.00	0.00	0.00	15%	978.00	68.78	\$ 7,497
Change request to laminate the vision glass at doors A & G to prevent easy entry into locked rooms.											\$ -
											\$ -
											\$ -
											\$ -
											\$ -
											\$ -
											\$ -
Sub-Total (by Labor / Material / Sub)											\$ 7,497
General Conditions										4.2%	\$ 315
Sub-Total											\$ 7,812
Contractors Fee										3.9%	\$ 305
TOTAL											\$ 8,117

72

NANO'S GLASS, INC.

8780 CASTNER DR., EL PASO, TX 79907
915-598-1850 / FAX 915-598-1827
nanoglass@sbcglobal.net

TRANSMITTAL

Contractor: VEMAC c/o Juan Contreras Date: August 22, 2014
Project Name: CONGRESSMAN REYES
Location 7440 NORTERN PASS
El Paso, TX 79911

AS REQUESTED INLIEU OF SPECIFIED 1/4" CLEAR TEMPERED CHANGE TO 1/4" CLEAR LAMINATED GLASS.

PLEASE PROVIDE A PROPOSAL FOR LAMINATED GLASS ON DOOR TYPES A, C and G.

TYPE A DOORS QTY OF 81 SINGLE QTY OF 6 PAIRS X 2= 12 TOTAL OF 93

TYPE C DOORS NOT USED

TYPE G DOORS QTY OF 10 SINGLE QTY OF 3 PAIRS X 2 = 6 TOTAL OF 16

GRAND TOTAL OF 109

NOTE: MFG CHARGES A MIN. OF 3 SQFT.

MATERIAL: \$6,519.00 (includes tempered glass credit)

15%MUP: \$978.00

TOTAL: \$7,497.00

QUALIFICATIONS AND OR EXCLUSIONS:

NOTE: LABOR & CAULKING REMAIN THE SAME

Sub total: _____
Tax: _____
Total Cost: AS NOTED

NOTE: Sign below to proceed with Change Order
Please return as soon as possible.

Approved by: _____
Print Name: _____
Title: _____
Date: _____

Prepared by: Irene Evans

nanoglass@sbcglobal.net

Juan Contreras

From: Irene Evans <nanosglass@sbcglobal.net>
Sent: Friday, August 22, 2014 10:13 AM
To: 'Juan Contreras'
Cc: 'Claudio Salinas'
Subject: RE: Reyes - Cost Proposal Vision Lite - Laminated Glass
Attachments: CISD change dr temp to lami 082214.pdf

Juan please find proposal attached.

Thank you,

Irene N. Evans

Nano's Glass, Inc.

From: Irene Evans [mailto:nanosglass@sbcglobal.net]
Sent: Friday, August 22, 2014 10:10 AM
To: 'Juan Contreras'
Cc: 'Claudio Salinas'
Subject: RE: Reyes - Cost Proposal Vision Lite - Laminated Glass

From: Juan Contreras [mailto:jcontreras@vemac.us]
Sent: Friday, August 15, 2014 2:35 PM
To: Irene Evans
Subject: Reyes - Cost Proposal Vision Lite - Laminated Glass

Irene,

Last email for the week.

CISD did not approve the proposal for wire mesh at the door vision lite yet would like a cost proposal to laminate the glass instead of the specified tempered glass. Please provide me a proposal for laminated glass on door A, C and G.

Thanks,

Juan
Project Manager
VEMAC
C - 915-526-8735

From: Hugo Saldana [mailto:hsaldana@cdaelpaso.com]
Sent: Wednesday, July 30, 2014 4:07 PM
To: Dominic Jose Padilla; Juan Contreras
Cc: Edgar Goytia-Chavez; Arlene Garcia
Subject: RE: Reyes, Change Order # 1 - Item 8

Dominic,

it is acceptable to use laminate glass on the classroom doors.

Juan,

Please provide CO proposal as requested by Dominic...

Thank you,

Hugo Saldaña, AIA, CNU-a



www.carldanielarchitects.com

From: Dominic Jose Padilla [<mailto:dpadilla@canutillo-isd.org>]

Sent: Wednesday, July 30, 2014 3:41 PM

To: Hugo Saldana

Cc: Edgar Goytia-Chavez; Arlene Garcia; Juan Contreras

Subject: RE: Reyes, Change Order # 1 - Item 8

Hugo,

If acceptable per code per seek a CO proposal from VEMAC to install laminate at these locations.

Thank you,

Dominic Padilla, LEED AP

Executive Director of Facilities & Transportation

Canutillo Independent School District

7710 Cap Carter

Canutillo, TX 79835

O 915-877-7712

M 915-727-1555

The Canutillo Independent School District does not discriminate on the basis of race, color, national origin, gender, age or disability in its employment practices, or in providing education services, activities and programs, including technical education programs. For more information regarding the Canutillo Independent School District policy of non-discrimination contact: Executive Director for Human Resources, (915) 877-7423, 7965 Artcraft Rd., El Paso, TX 79932.

El Distrito Escolar Independiente de Canutillo no discrimina en cuanto a raza, color, origen, género, edad o discapacidad en lo que se refiere a sus prácticas de empleo, o al proveer servicios, actividades y programas educativos y vocacionales. Para mayor información respecto a la política de no discriminación del Distrito Escolar Independiente de Canutillo, favor de contactar a: Director Ejecutivo de Recursos Humanos, (915) 877-7423, 7965 Artcraft Rd., El Paso, TX 79932.

From: Hugo Saldana [<mailto:hsaldana@cdaelpaso.com>]

Sent: Tuesday, July 29, 2014 12:52 PM

To: Dominic Jose Padilla

Cc: Edgar Goytia-Chavez; Arlene Garcia; Juan Contreras

Subject: RE: Reyes, Change Order # 1 - Item 8

Dominic,

Lindsay Holt send you an email regarding your question. I asked Lindsay, if laminated glass was more acceptable and the answer is yes.

Thank you,

Hugo Saldaña, AIA, CNU-a



www.carldanielarchitects.com

From: Dominic Jose Padilla [<mailto:dpadilla@canutillo-isd.org>]
Sent: Monday, July 28, 2014 3:26 PM
To: Hugo Saldana
Cc: Edgar Goytia-Chavez; Arlene Garcia; Juan Contreras
Subject: Reyes, Change Order # 1 - Item 8

Hugo,

Please provide us with the specific fire code prohibiting the installation of wire mesh at the locations outlined within the change order.

Additionally, please advise if laminated glass is an acceptable substitute for the wire mesh.

Thank you,

Dominic Padilla, LEED AP
Executive Director of Facilities & Transportation
Canutillo Independent School District
7710 Cap Carter
Canutillo, TX 79835
O 915-877-7712
M 915-727-1555

The Canutillo Independent School District does not discriminate on the basis of race, color, national origin, gender, age or disability in its employment practices, or in providing education services, activities and programs, including technical education programs. For more information regarding the Canutillo Independent School District policy of non-discrimination contact: Executive Director for Human Resources, (915) 877-7423, 7965 Arcraft Rd., El Paso, TX 79932.

El Distrito Escolar Independiente de Canutillo no discrimina en cuanto a raza, color, origen, género, edad o discapacidad en lo que se refiere a sus prácticas de empleo, o al proveer servicios, actividades y programas educativos y vocacionales. Para mayor información respecto a la política de no discriminación del Distrito Escolar Independiente de Canutillo, favor de contactar a: Director Ejecutivo de Recursos Humanos, (915) 877-7423, 7965 Arcraft Rd., El Paso, TX 79932.



This email is free from viruses and malware because [avast! Antivirus](#) protection is active.

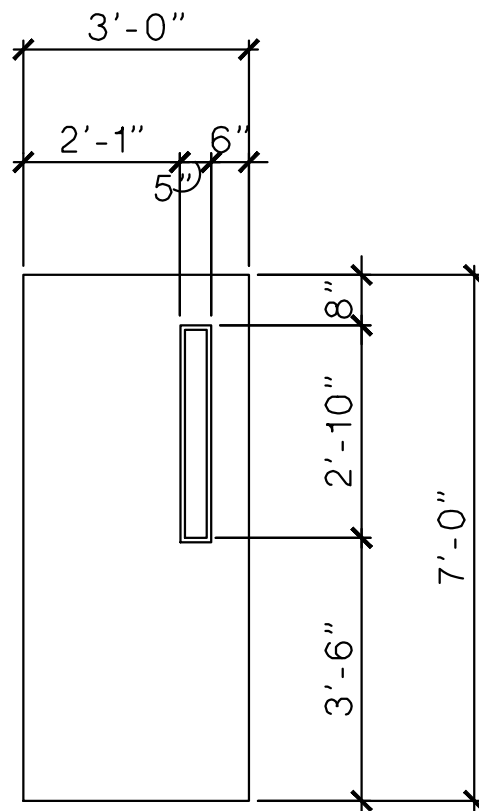

(A)

& G

A3.3 & A3.4



MEMORANDUM # 15

TO: Canutillo Independent School District

ATTN: Mr. Edgar Goytia-Chavez

CC: Juan Contreras

FROM: Hugo Saldaña, AIA

DATE: September 29, 2014

SUBJECT: Silvestre & Carolina Reyes School

RE: Proposal Request # 15

Attached is correspondence from VeMac requesting action concerning Proposal Request #15. CISD has requested that CDA makes recommendation on PCO # 15 and the following is our recommendations:

15– Provide rigid insulation were solid concrete panels are located as part of the coordination with the construction of thin shell panel. This will provide insulation at these areas and will help with the consumption energy.

Total proposal for this work is	\$10,269.00
---------------------------------	-------------

CDA and owner have reviewed the proposal and the breakdowns provided by the affected subcontractors. The proposal appears to be appropriate for the scope of work required. We recommend acceptance.

Hugo Saldana

From: Edgar Goytia-Chavez [egoytia@canutillo-isd.org]
Sent: Friday, September 26, 2014 7:42 AM
To: Juan Contreras; Dominic Jose Padilla
Cc: Hugo Saldana; Claudio Salinas; Oscar Venegas
Subject: RE: Reyes Rigid Insulation Area B, C & F

Thank you Juan.

Hugo,

Please provide a letter of recommendation on this.

CISD has no objections on using contractors contingency to cover this cost. We consider this change to be beneficial to the campus and CISD Energy Efficient Program.

Thank you,

Edgar Goytia

Bond Project Manager
Canutillo Independent School District
7710 Cap Carter
Canutillo, TX 79835
O 915-877-7751
M 915-241-7909
F 915-877-7740

The Canutillo Independent School District does not discriminate on the basis of race, color, national origin, gender, age or disability in its employment practices, or in providing education services, activities and programs, including technical education programs. For more information regarding the Canutillo Independent School District policy of non-discrimination contact: Executive Director for Human Resources, (915) 877-7423, 7965 Aircraft Rd., El Paso, TX 79932.

El Distrito Escolar Independiente de Canutillo no discrimina en cuanto a raza, color, origen, género, edad o discapacidad en lo que se refiere a sus prácticas de empleo, o al proveer servicios, actividades y programas educativos y vocacionales. Para mayor información respecto a la política de no discriminación del Distrito Escolar Independiente de Canutillo, favor de contactar a: Director Ejecutivo de Recursos Humanos, (915) 877-7423, 7965 Aircraft Rd., El Paso, TX 79932.

From: Juan Contreras [mailto:jcontreras@vemac.us]
Sent: Thursday, September 25, 2014 4:12 PM
To: Edgar Goytia-Chavez; Dominic Jose Padilla
Cc: Hugo Saldana; Claudio Salinas; Oscar Venegas
Subject: Reyes Rigid Insulation Area B, C & F

Dominic and Edgar,

Enclosed is a sketch of the areas on the east side of the building (area B, C & F) which Hugo indicated will require the additional 2 inch rigid insulation. The cost for the insulation and associated furring work is \$9,500 based on the bid unit price from Diversified Interiors. I estimate the electrician will charge +/- \$1,000 to provide extension rings for the power and data outlets on the exterior walls.

As this work could not be anticipated due to the design / build nature of the thin shell Vemac is willing absorb the cost under the contractor contingency. Please confirm you are in agreement and I will follow for the work.

Thanks,

Juan
Project Manager
VEMAC



Date: 09/29/14

Project : **CISD Silvestre and Carolina Reyes School**
 Project Contract No. : 282
 Location : 7440 Northern Pass, El Paso, TX 79911

PC No. 15

Proposed Change: **Rigid Insulation - Area B, C & F**
Contractor Contingency

DESCRIPTION	SUB	QTY.	UNIT	MATERIAL		LABOR		OVERHEAD & PROFIT		SUBTOTAL Bid Unit Price	
				Unit \$	TOTAL	Unit \$	TOTAL	%	TOTAL	Unit \$	TOTAL
Rigid Insulation	Diversified Int	4,560	EA							2.08	\$ 9,485
Add two (2) inch rigid insulation with furring channels to exterior thin shell panels at areas B, C & F per enclosed sketch dated 9/16/14. Total 4,560 square feet X \$2.08 / Sq. Ft. (bid amount 6/24/14) = \$9,485.00).											
											\$ -
											\$ -
											\$ -
											\$ -
											\$ -
											\$ -
											\$ -
Sub-Total (by Labor / Material / Sub)											
										\$ 9,485	
General Conditions										4.2%	\$ 398
Sub-Total											\$ 9,883
Contractors Fee										3.9%	\$ 385
TOTAL											\$ 10,269

08

7440 Northern Pass

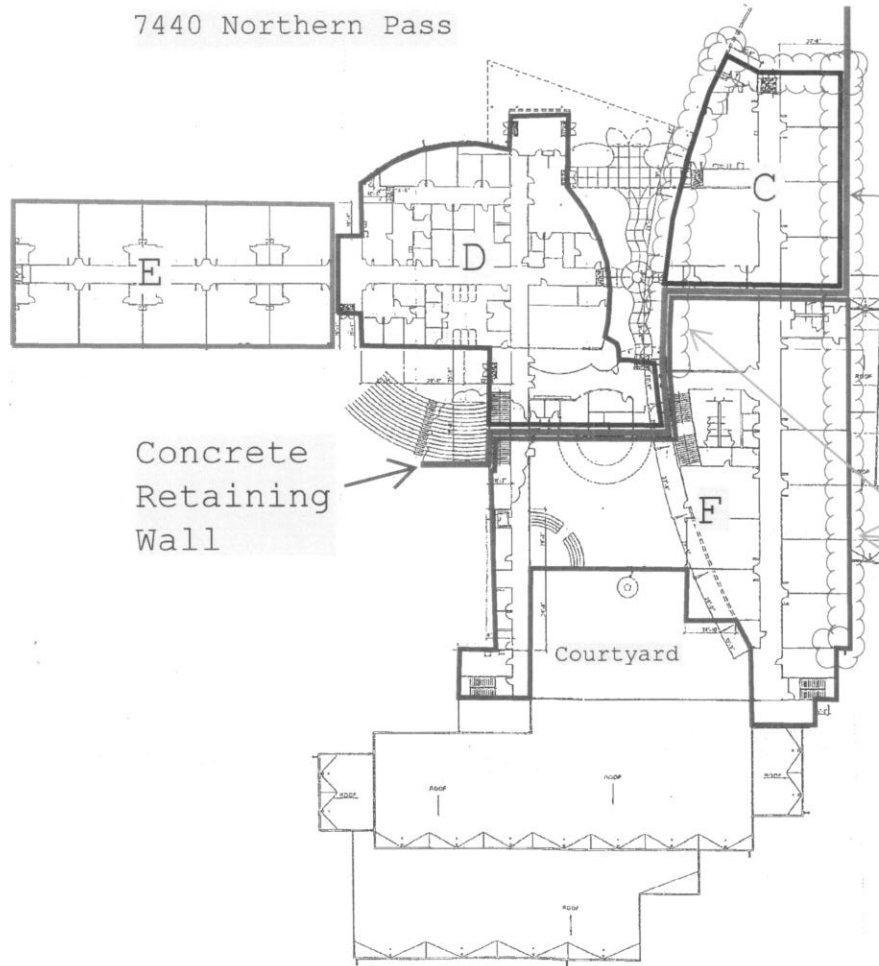

Street Level

Concrete Retaining Wall

Rigid Insulation

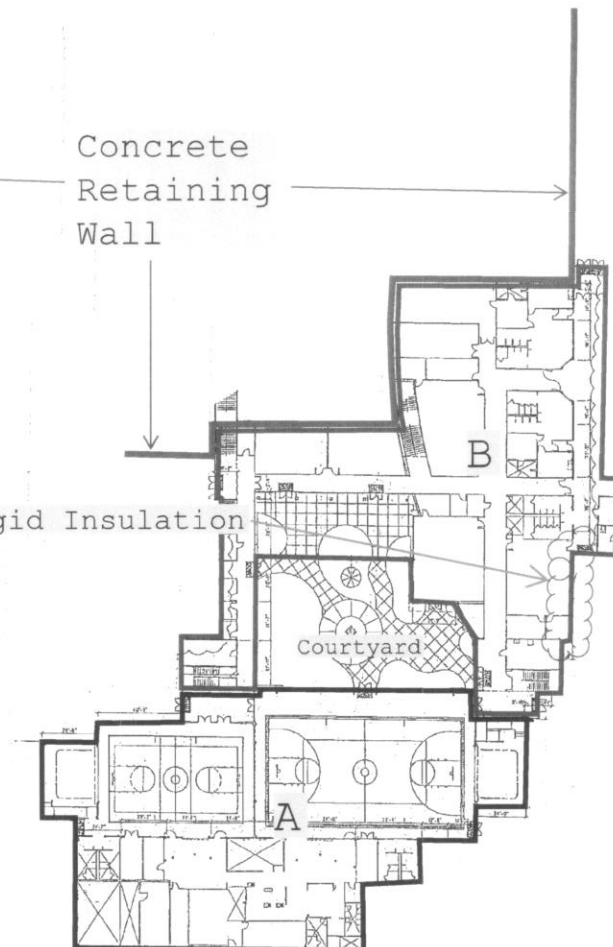

Lower Level



Reyes Elem School - CISD
7440 Northern Pass

Vemac 915-566-1911
Construction Sequence

Rigid Insulation
9/16/14

Concrete Retaining Wall

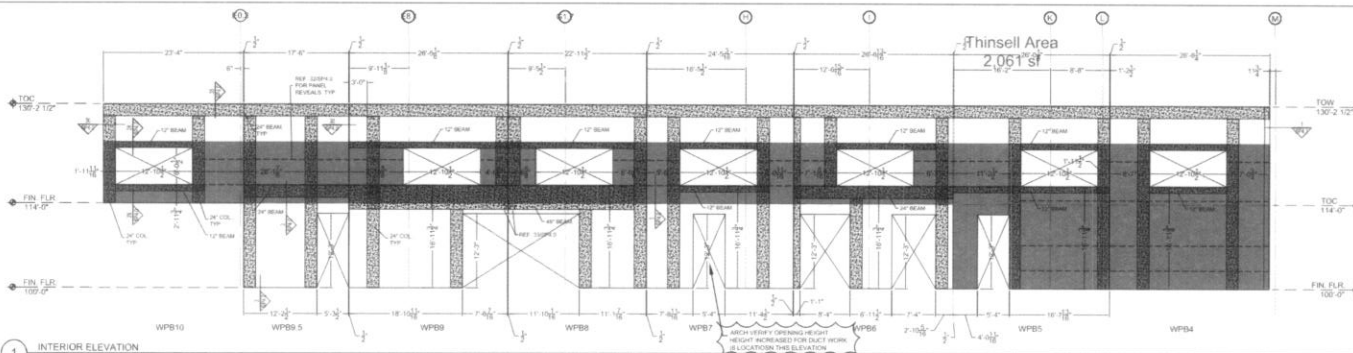

ARCH VERIFY PANEL REVEAL LOCATIONS REF. 32/SP4.0

MANY PANELS ARE COPIES OR MIRRORS OF DETAILED PANELS. REFERENCE SIMILAR PANELS FOR ADDITIONAL INFORMATION AND DETAILS. TYP

ROD ARE APPROXIMATE BASED ON 2 1/2\"/>

NOTE: REF. DETAIL 1/SP4.0 FOR TYPICAL CONDITIONS

1 INTERIOR ELEVATION 1/8\"/>

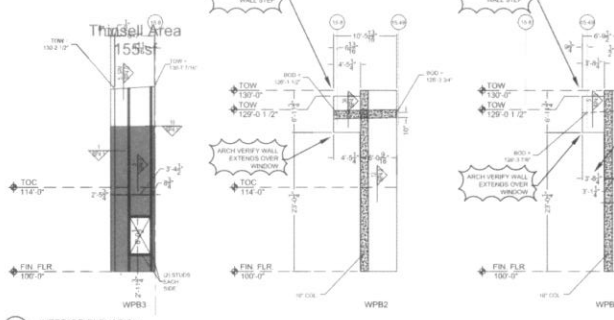

2 INTERIOR ELEVATION 1/8\"/>

3 INTERIOR ELEVATION 1/8\"/>

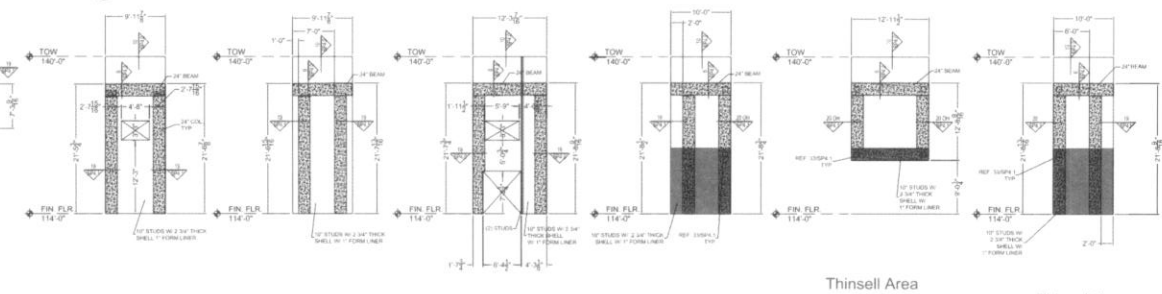

4 INTERIOR ELEVATION 1/8\"/>

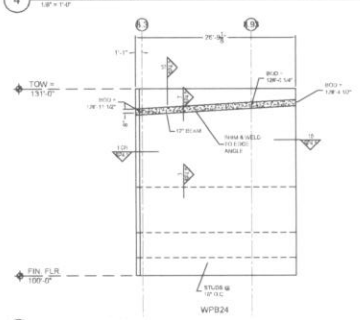

5 INTERIOR ELEVATION 1/8\"/>

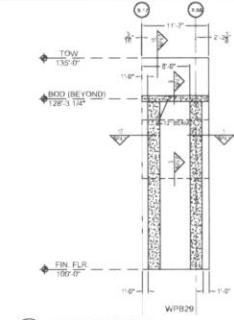

6 INTERIOR ELEVATION 1/8\"/>



7 INTERIOR ELEVATION 1/8\"/>

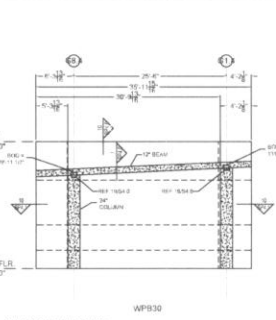

Thinsell Area 110 sf

Thinsell Area 26 sf WPB12

Thinsell Area 110 sf

Total 4,560 sq. ft.

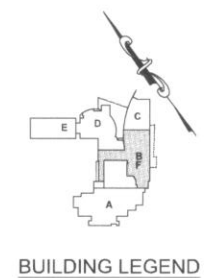

BUILDING LEGEND

6001 W. WILLIAM CANYON
BUILDING 2, SUITE 203-C
AUSTIN, TEXAS 78748
512.301.3388 (O)
512.301.3348 (F)

TEXAS DESIGN INTERESTS, LLC
AUSTIN, TEXAS
COMMERCIAL/RESIDENTIAL CIVIL & STRUCTURAL ENGINEERING

CANUTILLO INDEPENDENT SCHOOL DISTRICT
CONGRESSMAN SILVESTRE & CAROLINA REYES SCHOOL
7440 NORTHERN PASS, EL PASO TEXAS 79911

JEFFREY E. CLOYD
180243
REGISTERED PROFESSIONAL ENGINEER
CIVIL
FIRM REG. # 2851

PANEL ELEVATIONS
PROJECT # 308-193
DATE 05/22/14

SHEET
SP3.2

DIVERSIFIED INTERIORS

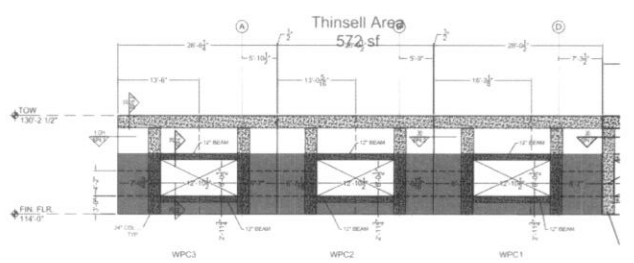
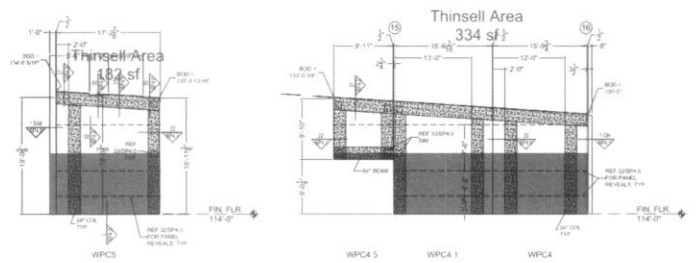

ARCH VERIFY PANEL REVEAL LOCATIONS REF. 32/SP4.2

MANY PANELS ARE COPIES OR MIRRORS OF DETAILED PANELS. REFERENCE SIMILAR PANELS FOR ADDITIONAL INFORMATION AND DETAILS. TYP.

BOB ARE APPROXIMATE BASED ON 2 1/2" JOIST BEARING.

NOTE: REF DETAIL 1/SP4.8 FOR TYPICAL CONDITIONS.

1 INTERIOR ELEVATION 1/8" = 1'-0"

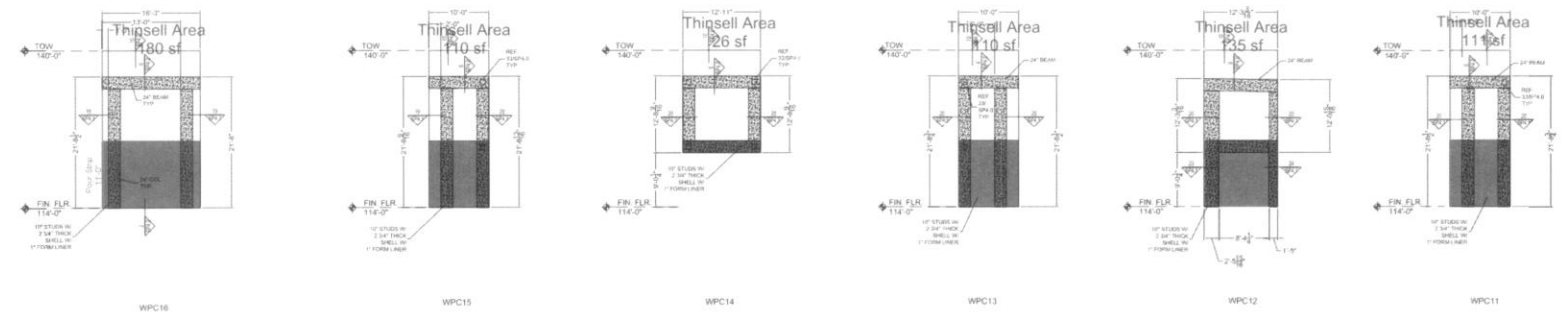

2 INTERIOR ELEVATION 1/8" = 1'-0"

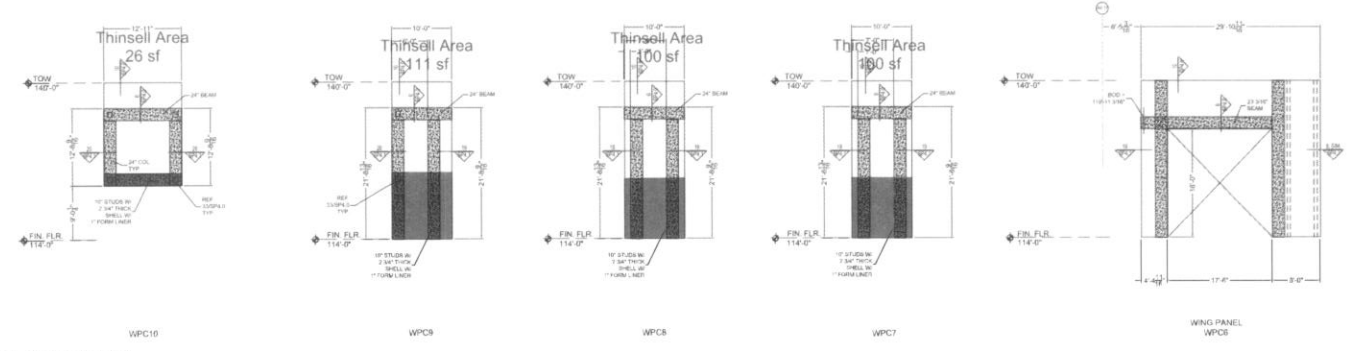

3 INTERIOR ELEVATION 1/8" = 1'-0"

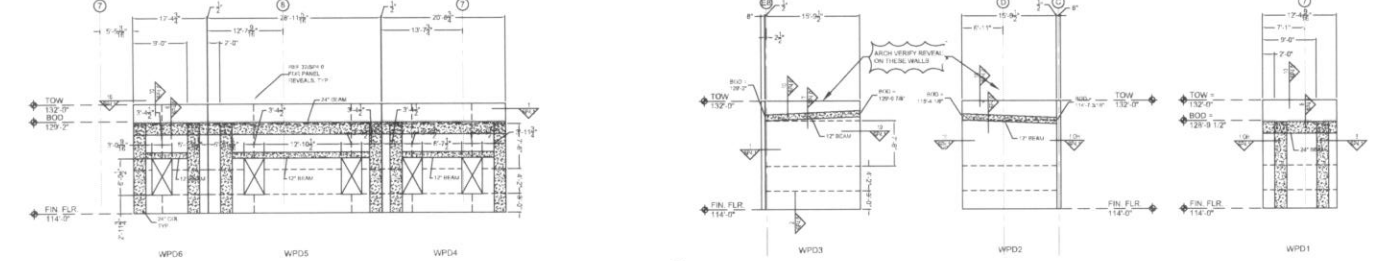

4 INTERIOR ELEVATION 1/8" = 1'-0"

5 INTERIOR ELEVATION 1/8" = 1'-0"

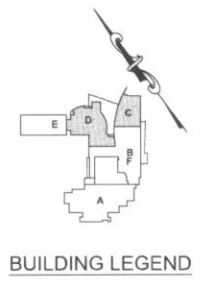

6001 W. WILLIAM CANNON
AUSTIN, TX 78748
(512) 301-3388 (O)
(512) 301-3348 (F)

TEXAS
DESIGN
INTERESTS, LLC
ARCHITECT + ENGINEER

COMMERCIAL/RESIDENTIAL - CIVIL & STRUCTURAL ENGINEERING

CANUTILLO INDEPENDENT SCHOOL DISTRICT
CONGRESSMAN SILVESTRE & CAROLINA REYES SCHOOL
7440 NORTHERN PASS, EL PASO TEXAS 79911
DIVERSIFIED INTERIORS

JEFFREY E. CLOYD
REGISTERED ARCHITECT
NO. 00247
STATE OF TEXAS
FIRM REG. # 7-8621

PANEL ELEVATIONS
PROJECT # 308-193
DATE 06/01/14
SHEET SP3.3



BID FORM

Project Name: Congressman Silvestre and Carolina Reyes Pre-K through 8th Grade School

Project Address: 7410 Northern Pass, El Paso, TX 79911

Bidders Name: Diversified Interiors
Bidders Address: 4750 Ripley, El Paso, TX 79922

Venegas Engineering Management and Construction, Inc.
 1919 E. Rio Grande
 El Paso, TX, 79902

Having Carefully examined the bid form, general conditions of the contract, supplementary general conditions, special conditions, instructions to bidder, plans, specs and addenda (if applicable). The undersigned proposed to furnish all labor, materials and equipment necessary to complete the entire work for the following scope of work.
 Please Select

07-21-00 Building Insulation

\$ 90,800⁰⁰

Alternate #1 2" XPS Insulation Sheets w/ Thin-shell panels

\$ 91,400⁰⁰ *

*Note: Amount shall be shown in both written and figure form. In case of discrepancy between the written amount and the figure, the written amount will govern.

The undersigned further agrees, if awarded the contract, to complete all work as outlined by the plans and Specifications as indicated within the allotted time.

Receipt is hereby acknowledged of the following addenda

- # 1 Dated 6-16-2014
- # 2 Dated 6-18-2014
- # Dated

Approx sq. ft. 44,000
 $\$91,400 / 44,000 = \$2.08/SF$

Vemac 8/26/14
 Juan contreras 526-8735

VEMAC

Vertical Excavation, Masonry & Concrete



The undersigned agrees, if awarded the contract, to execute the contract and furnish the required insurance certificates, submittals, safety plan, MSDS within (10) ten days after notification of award and to commence work within ten (10) days from notice to proceed from the Construction Manager.

The undersigned proposes to guarantee in writing, for the period required in the specifications, all work performed under the contract document, and to repair and maintain the project until the date of acceptance. The undersigned further proposes, and will so state in his written guarantees, to maintain the entire construction and do repair defects of any kind for a period of one year from date of acceptance, or for a longer period if so required in the specifications, for certain materials and/or processes. It is understood that the Owner reserves the right to accept or reject any and all proposals and to waive bidding irregularities.

Respectfully submitted,

Firm: *Diversified Interiors of El Paso*

Printed Name: *Andrew Hawley*

Title: *Vice President*

Business Address: *4750 Ripley, El Paso, TX 79922*

Date: *6-24-2014*

(SEE ALL if bid by corporation)

** Pricing for A14. #1
includes \$18,200.00
for furring of walls.*



MEMORANDUM # 21

TO: Canutillo Independent School District

ATTN: Mr. Edgar Goytia-Chavez

CC: Juan Contreras

FROM: Hugo Saldaña, AIA

DATE: October 2, 2014

SUBJECT: Silvestre & Carolina Reyes School

RE: Proposal Request # 21

Attached is correspondence from VeMac requesting action concerning Proposal Request #21. CISD has requested that CDA makes recommendation on PCO # 21 and the following is our recommendations:

21– The contractor suggested that the enclosed chain link fence area at the service yard have a flat patio area for storing of pipes and other material. CISD agreed and requested modification.

Total proposal for this work is \$7,054.00

CDA and owner representative have reviewed the proposal and the breakdowns provided by the affected subcontractors. The proposal appears to be appropriate for the scope of work required. We recommend acceptance.



Date: 09/30/14

Proposed Change (PC) No. 21

Project : CISD Silvestre and Carolina Reyes School
 Project Contract No. : N/A
 Location : Canutillo, TX

Proposed Change: **RFI 95 - Service Yard Stem Wall**

DESCRIPTION	SUB Subcontr.	Qty.	UNIT	MATERIAL		LABOR		OVERHEAD & PROFIT		SUBTOTAL	
				Unit \$	TOTAL	Unit \$	TOTAL	%	TOTAL	Unit \$	TOTAL
Backfill	VEMAC	166	CY	\$ 3.31	\$ 55C.00	\$ 8.50	\$ 1,411.20	15%	\$ 294.18	\$ 13.59	\$ 2,255.38
Stemwall	VEMAC	90	LF	\$ 15.78	\$ 1,42C.00	\$ 25.39	\$ 2,284.80	15%	\$ 555.72	\$ 47.34	\$ 4,260.52
											\$ -
											\$ -
											\$ -
											\$ -
											\$ -
											\$ -
Sub-Total (by Labor / Material / Sub)											\$ 6,516
										General Conditions	4.2% \$ 274
										Sub-Total	\$ 6,790
										Contractors Fee	3.9% \$ 265
										TOTAL	\$ 7,054

87

RFI 95 - Service Yard Stem Wall

09/30/14
21

PC No.

		Qty	Hrs	Total				
<u>Backfill</u>								
Backfill & Regrade	Carp / Oper	1	16	16	\$	15.00	\$	240.00
	Lab	4	16	64	\$	12.00	\$	768.00
							Subtotal	\$ 1,008.00
Labor Burden							40%	\$ 403.20
							Total Labor	\$ 1,411.20

<u>Stemwall</u>								
Form	Carp	2	24	48	\$	15.00	\$	720.00
	Lab	2	24	48	\$	12.00	\$	576.00
Strip & Clean	Lab	2	8	16	\$	12.00	\$	192.00
Finish Vert Wall	Finisher	1	8	8	\$	18.00	\$	144.00
							Subtotal	\$ 1,632.00
Labor Burden							40%	\$ 652.80
							Total Labor	\$ 2,284.80

Materials / Equipment / Lodging

Backfill

Misc Equipment - Backhoe Rental \$ 550.00

Stemwall

Conc Wall								
Conc - 4 yd min				13.00	\$	90.00	\$	1,170.00
Rebar / Mesh							\$	250.00
							Subtotal	\$ 1,420.00

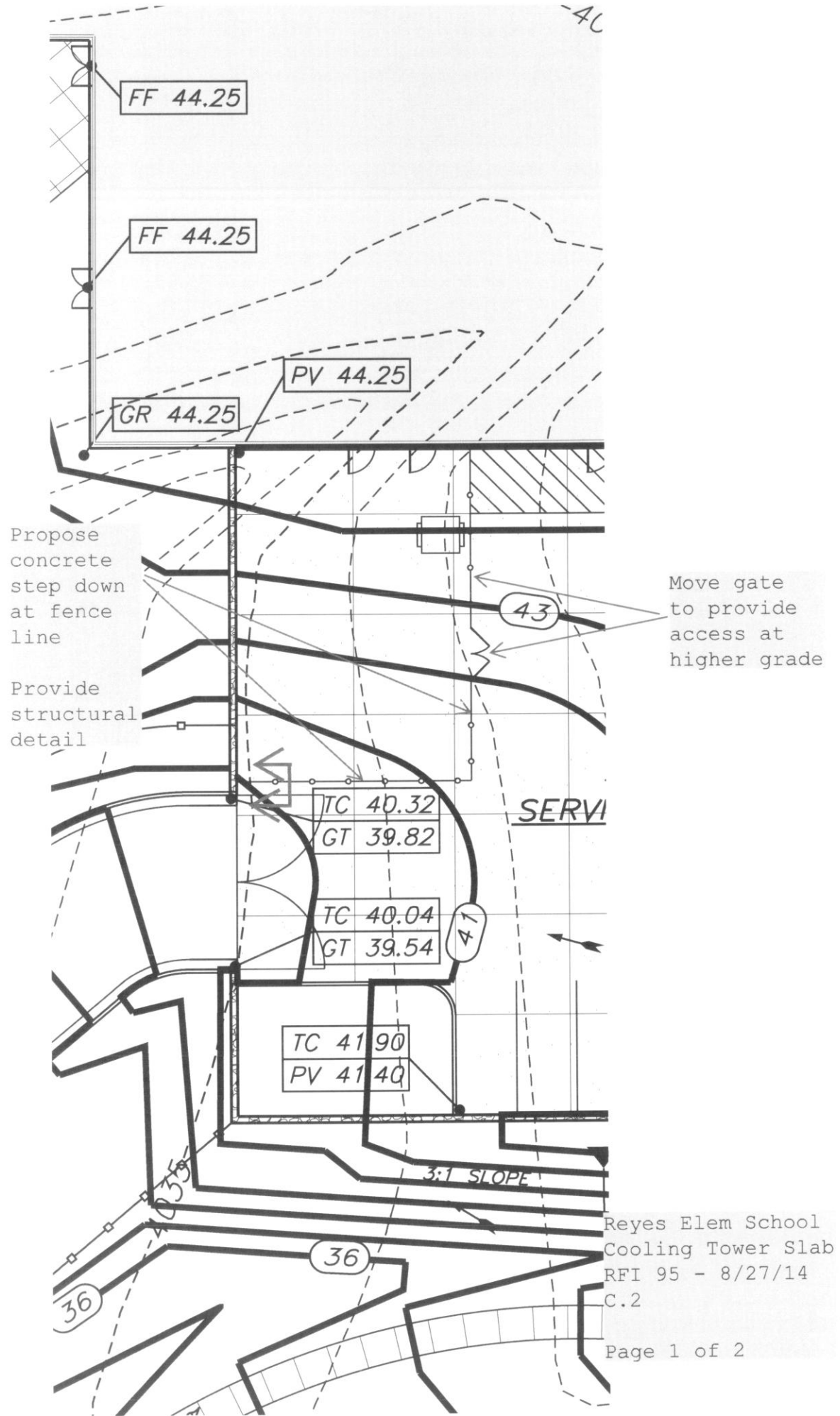

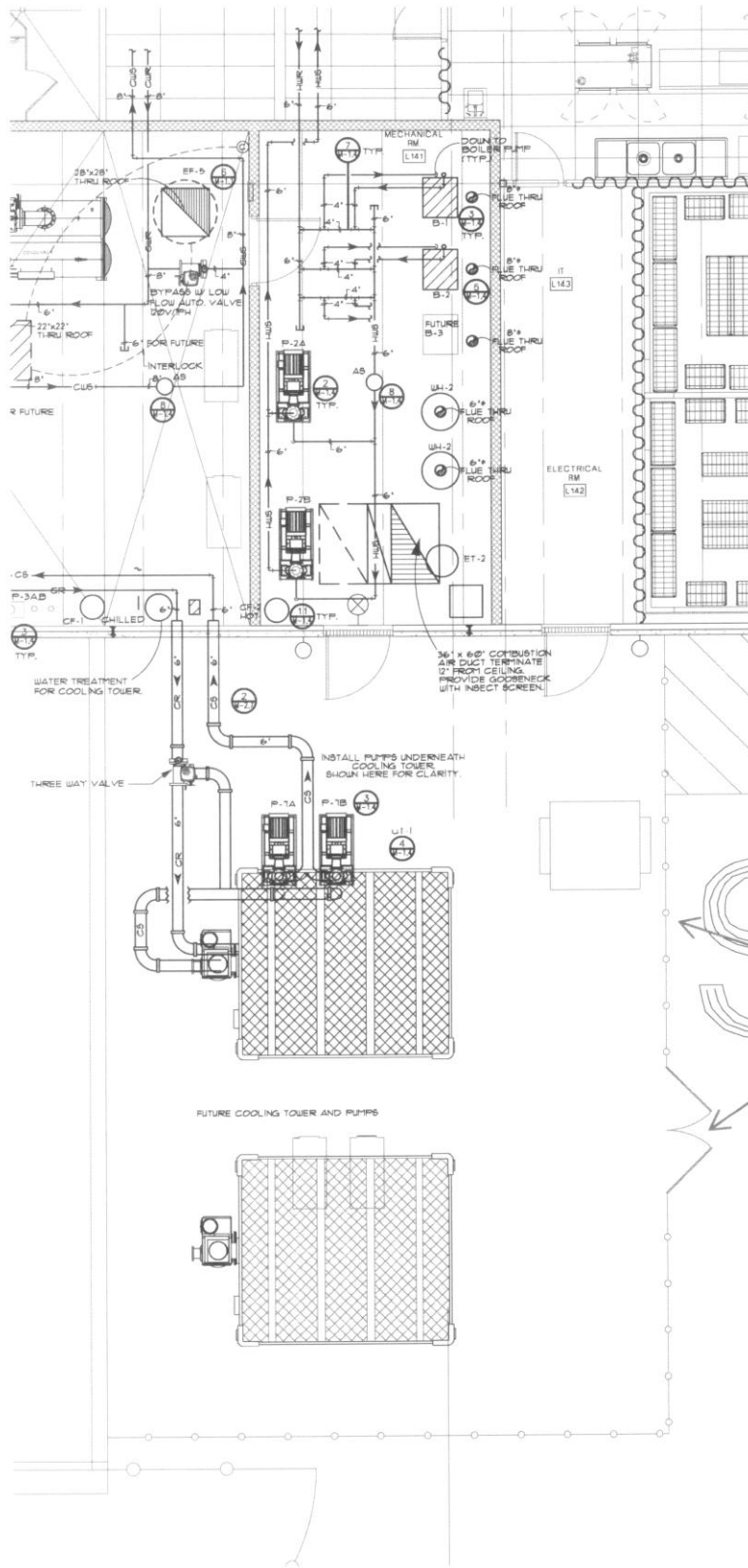

Move gate to provide access at higher grade

Reyes Elem School
 Cooling Tower Slab
 RFI 95 - 8/27/14
 M2.7

MECHANICAL YARD PLAN - LOWER LEVEL
 M.E. 1/4" = 1'-0"

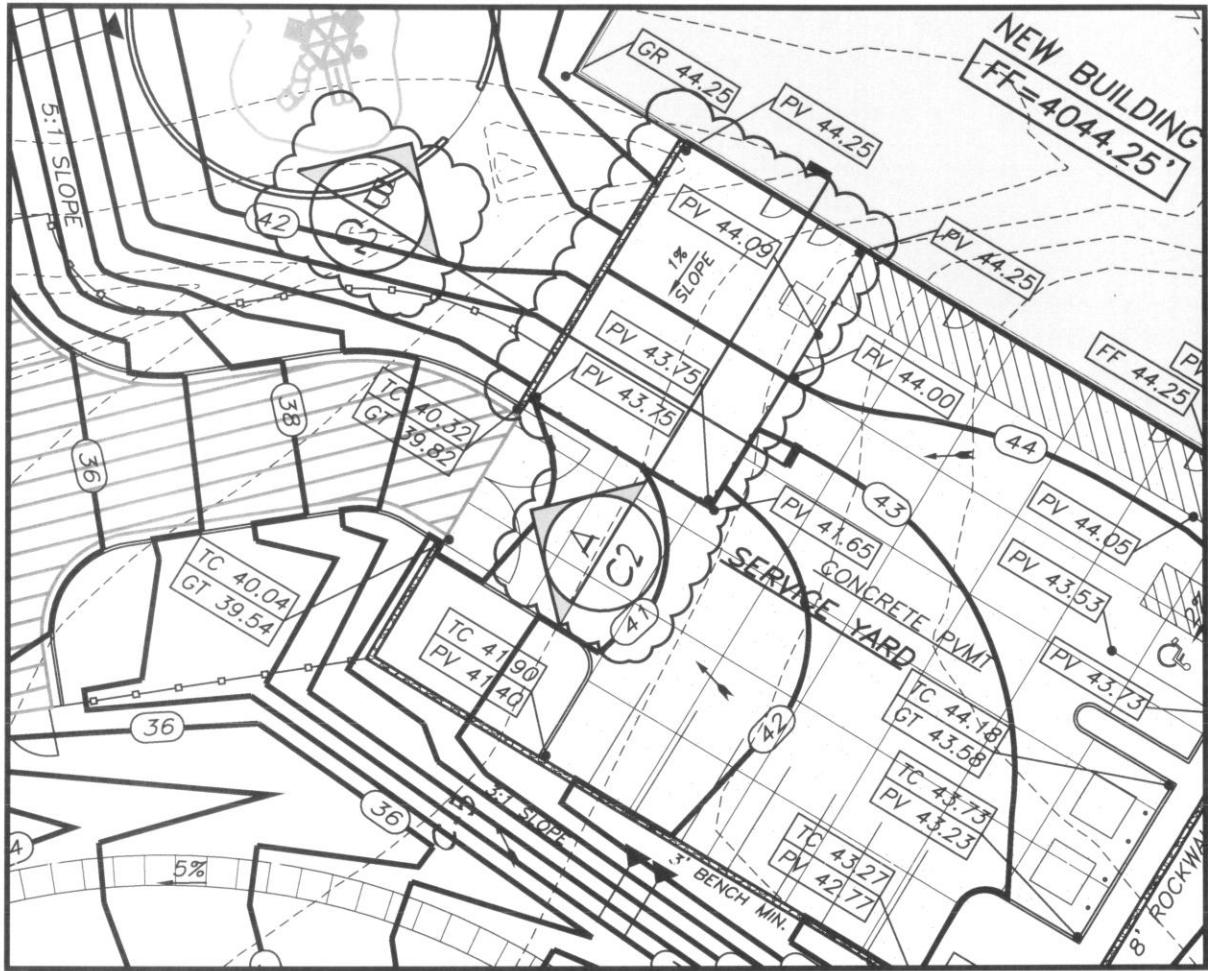

PARTIAL GRADING PLAN

SCALE: 1" = 30'-0"

REVISION RECAP
 NEW CONCRETE PAD FOR COOLING TOWER



[Signature]
 9/08/2014

PREPARED BY:  SITework ENGINEERING L. L. C. TX REG. # F-5607	CONGRESSMAN SILVESTRE & CAROLINA REYES SCHOOL		RFI#95 C-1
	DRAWN BY: PRZ	DATE: 09/08/14	
	CHECKED BY: JAG	DRAWING NO: RFI#95	
	JOB NO: 12004	SHEET 1 OF 4	

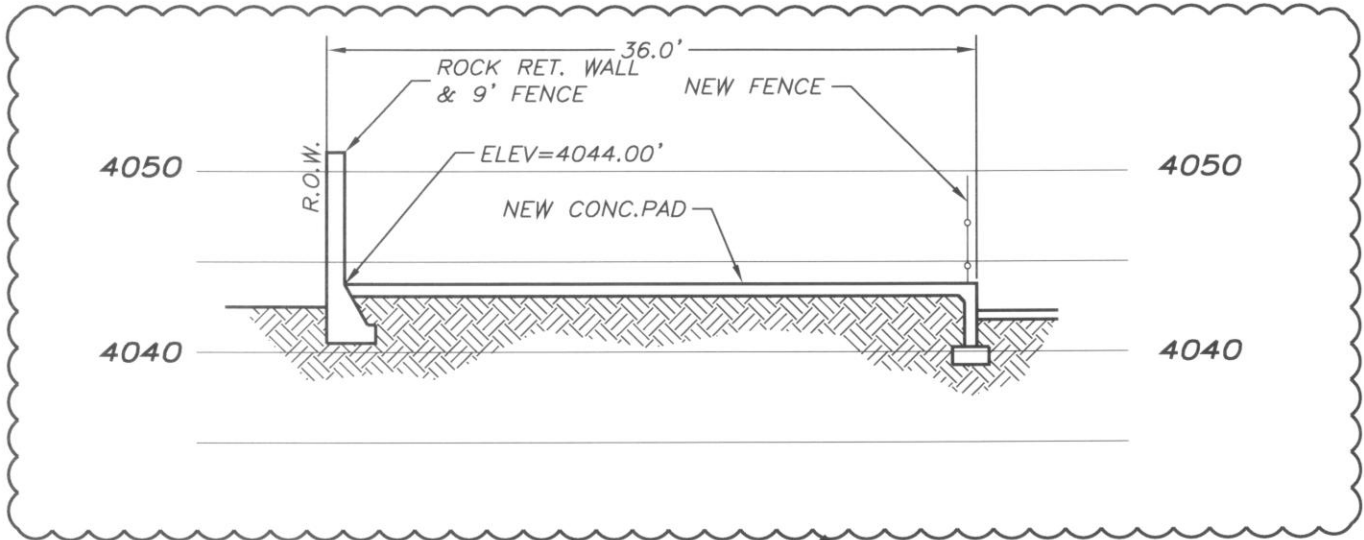

SECTION A-A

SCALE: 1" = 10'-0"

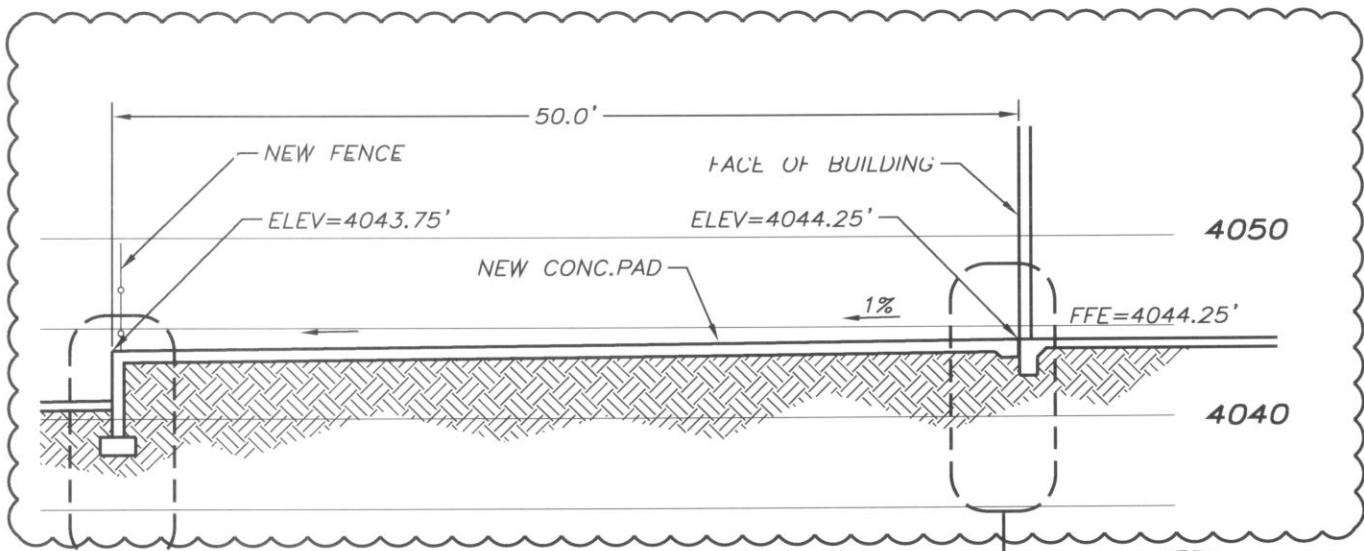

SECTION B-B'

SCALE: 1" = 10'-0"

C
C3

D
C4

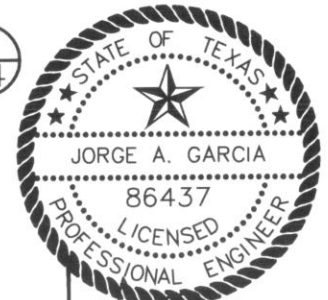

[Signature]
9/08/2014

REVISION RECAP
NEW CONCRETE PAD FOR COOLING TOWER

PREPARED BY:  SITework ENGINEERING L. L. C. TX REG. # F-5607	CONGRESSMAN SILVESTRE & CAROLINA REYES SCHOOL		RFI#95 C-2
	DRAWN BY: PRZ	DATE: 09/8/14	
	CHECKED BY: JAG	DRAWING NO: RFI#95	
	JOB NO: 12004	SHEET 2 OF 4	

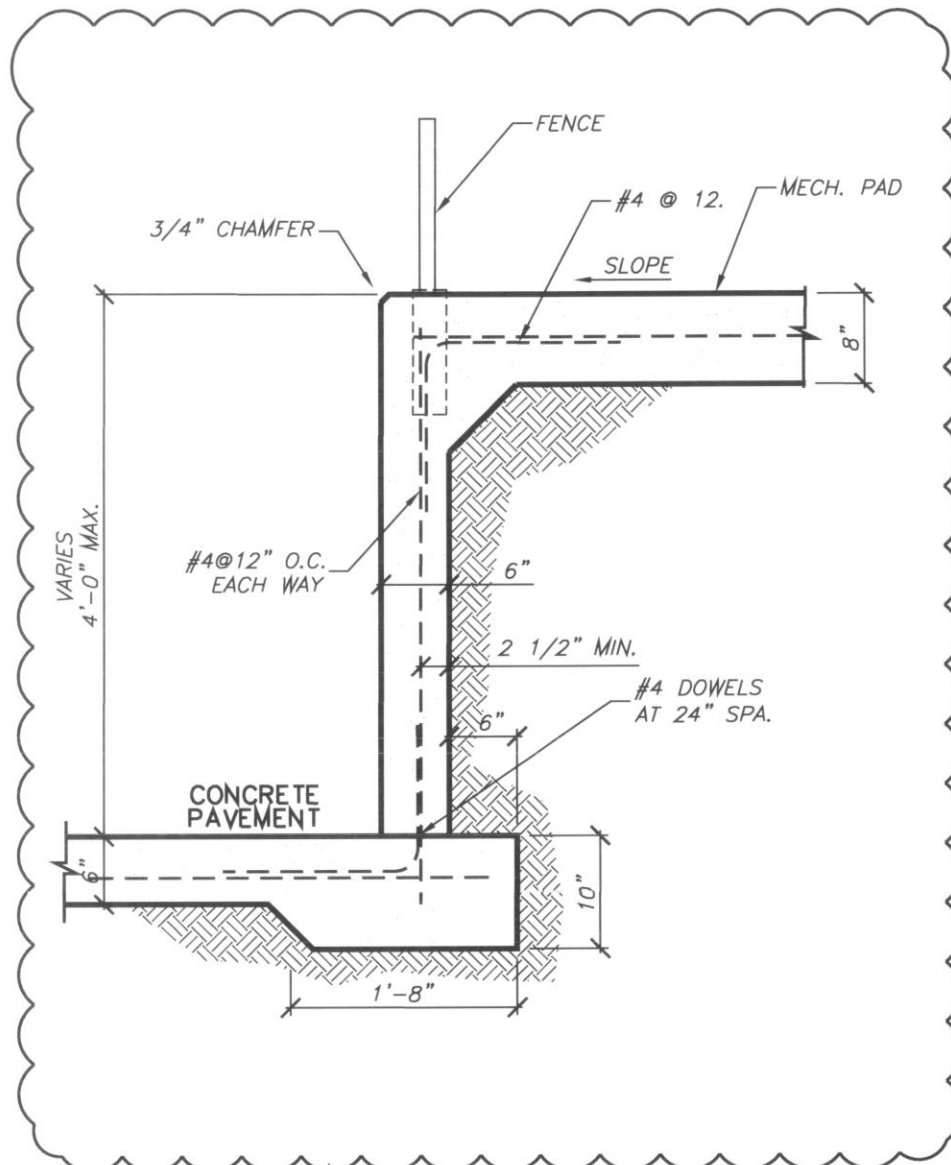

SECTION

SCALE: 3/4" = 1'-0"

REVISION RECAP
 NEW CONCRETE PAD FOR COOLING TOWER



Jorge A. Garcia
 9/12/2014

PREPARED BY:  SITWORK ENGINEERING L. L. C. TX REG. # F-5607	CONGRESSMAN SILVESTRE & CAROLINA REYES SCHOOL		RFI#95 C-3
	DRAWN BY: PRZ	DATE: 09/12/14	
	CHECKED BY: JAG	DRAWING NO: RFI#95	
	JOB NO: 12004	SHEET 3 OF 4	

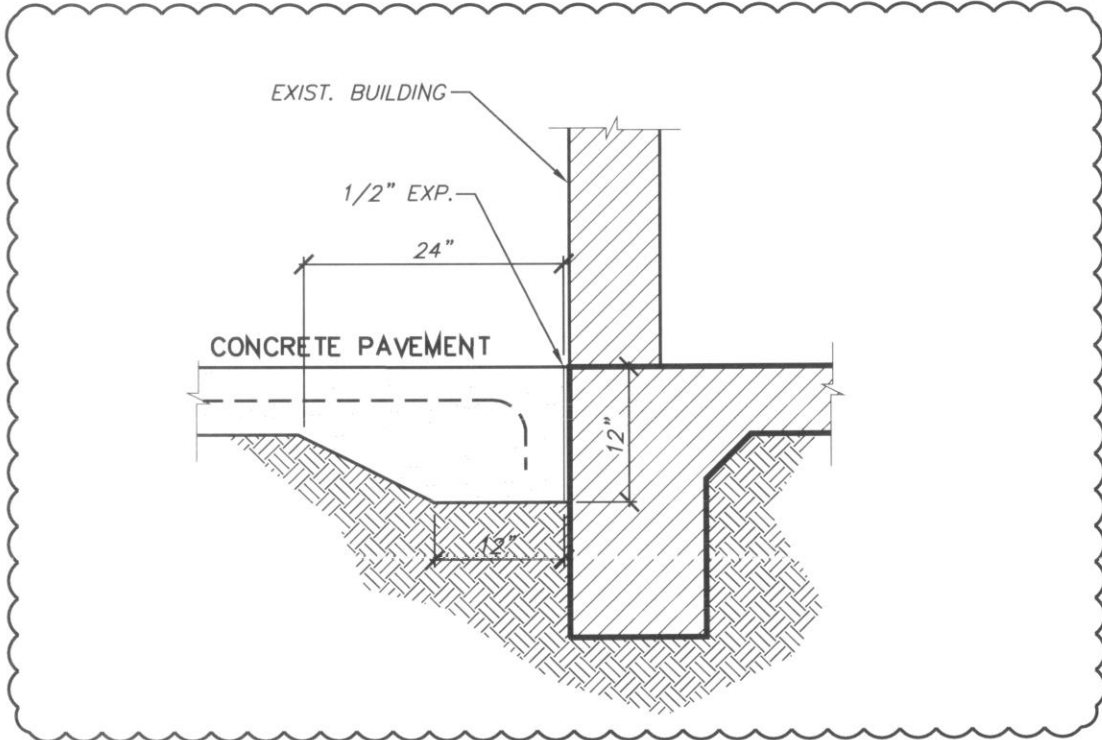

D SECTION
 SCALE: 3/4" = 1'-0"

REVISION RECAP
 NEW CONCRETE PAD FOR
 COOLING TOWER



Jorge A. Garcia
 9/08/2014

PREPARED BY:  SITework ENGINEERING L. L. C. TX REG. # F-5607	CONGRESSMAN SILVESTRE & CAROLINA REYES SCHOOL		RFI#95 C-4
	DRAWN BY: PRZ	DATE: 09/08/14	
	CHECKED BY: JAG	DRAWING NO: RFI#95	
	JOB NO: 12004	SHEET 4 OF 4	



MEMORANDUM # 22

TO: Canutillo Independent School District

ATTN: Mr. Edgar Goytia-Chavez

CC: Juan Contreras

FROM: Hugo Saldaña, AIA

DATE: October 2, 2014

SUBJECT: Silvestre & Carolina Reyes School

RE: Proposal Request # 22

Attached is correspondence from VeMac requesting action concerning Proposal Request #22. CISD has requested that CDA makes recommendation on PCO # 22 and the following is our recommendations:

22– The City of El Paso Fire Department through the City Permit requested that the bus drop off be closer to the school. Additional concrete pavement is required to meet this request.

Total proposal for this work is \$5,287.00

CDA and owner representative have reviewed the proposal and the breakdowns provided by the affected subcontractors. The proposal appears to be appropriate for the scope of work required. We recommend acceptance.



Date: 09/30/14

Proposed Change (PC) No. 22

Project : CISD Silvestre and Carolina Reyes School
 Project Contract No. : 312
 Location : Canutillo, TX

Proposed Change: **Additional paving at permit-revised bus drop-off area**

DESCRIPTION	SUB Subcontr.	QUANTITY	UNIT	MATERIAL		LABOR		OVERHEAD & PROFIT		SUBTOTAL	
				Unit \$	TOTAL	Unit \$	TOTAL	%	TOTAL	Unit \$	TOTAL
Concrete Paving - 8 Inch	VEMAC	3,500	SF	0.73	2,550.00	0.48	1,696.80	15.00%	637.02	1.40	\$ 4,884
											\$ -
											\$ -
											\$ -
											\$ -
											\$ -
											\$ -
											\$ -
Sub-Total (by Labor / Material / Sub)											\$ 4,884
										General Conditions	4.2% \$ 205
										Sub-Tctal	\$ 5,089
										Contractors Fee	3.9% \$ 198
										TOTAL	\$ 5,287

97

Additional paving at permit-revised bus drop-off area

09/30/14
22

PC No.

		Qty	Hrs	Total				
Regrade	Carp	1	16	16	\$	15.00	\$	240.00
	Lab	3	16	48	\$	12.00	\$	576.00
Form / Place Conc	Carp	1	4	4	\$	15.00	\$	60.00
	Lab	2	4	8	\$	12.00	\$	96.00
	Finisher	2	4	8	\$	18.00	\$	144.00
Strip& Clean	Carp	0	4	0	\$	15.00	\$	-
Caulk	Lab	2	4	8	\$	12.00	\$	96.00
								Subtotal
								\$ 1,212.00
Labor Burden							40%	\$ 484.80
								Total Labor
								\$ 1,696.80

Materials / Equipment / Lodging

Conc - 4 yd min				20.00	\$	100.00	\$	2,000.00
Misc Equipment Backhoe 1 day							\$	250.00
Rebar / Mesh							\$	250.00
Caulk material							\$	50.00
								Total Materials
								\$ 2,550.00
								Total
								\$ 4,246.80



Canutillo Independent School District

7965 Artcraft Road
El Paso, Texas 79932

Mailing Address: P. O. Box 100
Canutillo, Texas 79835

CAREER AND TECHNICAL EDUCATION

Tel: (915) 877-7563

Fax: (915) 877-7478

Jan Massie

Director
(915) 877-7575

jmassie@canutillo-isd.org

Sonia Calvillo

Administrative Secretary
(915) 877-7563

scalvillo@canutillo-isd.org

TO: Dr. Pedro Galaviz
Superintendent

XC: Annette Brigham
Associate Superintendent

FROM: Jan Massie
Director, Career and Technical Education

RE: Report: CTE Program

DATE: October 7, 2014

Please accept this request to address the CISD Board of Trustees.

The Canutillo Independent School District does not discriminate on the basis of race, color, national origin, gender, age or disability in its employment practices, or in providing education services, activities and programs, including technical education programs. For more information regarding the Canutillo Independent School District policy of non-discrimination contact: Executive Director of Human Resources, (915) 877-7423, 7965 Artcraft Rd., El Paso, TX. 79932.

El Distrito Escolar Independiente de Canutillo no discrimina en cuanto a raza, color, origen, género, edad o discapacidad en lo que se refiere a sus prácticas de empleo, o al proveer servicios, actividades y programas educativos y vocacionales. Para mayor información respecto a la política de no discriminación de Distrito Escolar Independiente de Canutillo, favor de contactar a: Director Ejecutivo de Recursos Humanos, (915) 877-7423, 7965 Artcraft Rd., El Paso, TX. 79932.

REPORT: CAREER AND TECHNICAL EDUCATION

2014-15

1. **BUDGET** **PERKINGS:** \$85,562 **LOCAL FUNDS:** \$725,579
2. **STUDENT POPULATION** as of 10/2/13
1,638 (CHS) as of 10/2/14
283 (NWECS)
3. **CTE STAFF:** 18 TEACHERS AT CHS
1 TEACHER AT NWECS
1 SECRETARY
1 TECHNOLOGY TECH
1 COUNSELOR
DIRECTOR
4. **CTE ENDORSEMENT AREAS:** STEM, BUSINESS & INDUSTRY, PUBLIC SERVICE
REFER TO CHART FOR CLASS LISTINGS AND CERTIFICATIONS
5. **EVALUATION OF PROGRAM**
ADVISORY BOARD 2013-14
WIN Corporation 2014-15: The WIN Corporation has been retained to evaluate the present CTE program, economic development and current and projected workforce demands in El Paso and surrounding areas. Information provided from this report will be used to create CTE career pathways for the 2015-16 school year. A preliminary report from WIN will be presented October 21st with the final report due October 27th.
6. **STUDENT ORGANIZATIONS:**
DECA: MARKETING
FFA : AGRICULTURE
HOSA: HEALTH OCCUPATIONS STUDENTS OF AMERICA
FCCLA: FAMILY, CAREER& COMMUNITY LEADERS
BPA: BUSINESS PROFESSIONALS OF AMERICA
FBLA: FUTURE BUSINESS LEADERS OF AMERICA
TSA: TECHNOLOGY STUDENTS OF AMERICA
NTHS: NATIONAL TECHNOLOGY HONOR SOCIETY
TEXAS SKILLS U.S.A.
7. **ADVISORY BOARD MEMBERS**
MR. MICHAEL SAENZ, WALGREENS
MR. ROMAN BUSTILLOS, BROCK & BUSTILLOS, INC.
MR. ROMAN WILCOX, SYSCO
MR. EDGAR FLORES, WELLS FARGO BANK
MR. CRUZ GUTIERREZ, GRAN TURISMO GRAPHIX
MR. ISAIAH KENNEDY, APPLEBEES
MS. LISA LUNCEFORD, GRACE GUARDIANS
MR. BILLY MASSIE, EL PASO ELECTRIC
MR. CHRIS MONTOYA, ADVENTURES IN LEARNING
SGT. PET SALCEDO & OFFICER SAL VILLALOBOS, EL PASO POLICE DEPT.
MR. RICK VILLARREAL, VILLARREAL & SONS ELECTIRC
MR. ENRIQUE VILLATORO, BIENVIVIR
MR. MICHAEL WALDO, EL PASO ELECTRICIANS JATC
MS. CAITLIN BRIGHAM, CHEDDARS

MR. WILLIE DE LA ROSA, SYSCO FOODS
MR. RENE MELENDEZ, CEA GROUP

8. PARTNERSHIPS

GECU, FRANKLIN NURSING HOME, WALGREENS, FEDERAL CREDIT UNION, WHITE ACRES, LAS PALMAS

Notes:

1. \$56,000.00 WILL BE PAID TO EPISD (CCTE) FOR STUDENT'S ATTENDING CLASSES THERE
2. Barn
3. Vehicle Storage Unit
4. CTE center

2.-4. I met with Mr. Padilla on Tuesday, October 07, 2014 to discuss the possibility of constructing a vehicle storage unit, construction of a barn and a CTE center. After a lengthy discussion it was concluded that these items should become points of discussion during the process of creating the Facility Master Plan.

CANUTILLO HIGH SCHOOL

CAREER CLUSTER	PATHWAY	9 TH GRADE	10 TH GRADE	11 TH GRADE	12 TH GRADE
Agriculture, Food & Natural Resources Endorsement: Business & Industry	Animal Science	Principals of Agriculture, Food & Natural Resources	Livestock/Small Animal Veterinary	Veterinary Medical Applications	Advanced Animal Science Practicum in AFNR
	Power, Structural & Technical Systems		Agriculture Mechanics & Metal Technologies	Ag Facilities & Design (Double Block)	Ag Power Systems (Double Block)
Arts, A/V Technology & Communications Endorsement: Business & Industry	Printing Technologies Graphic Design	Principals of Information Technology	Graphic Design	Advanced Graphic Design & Illustration (Double Block)	Advanced Graphic Design Practicum (DB)
			Digital & Interactive Multimedia (animation)	Web Technology	Audio Visual Production
Business Management & Administration Endorsement: Business & Industry	Administrative & Information Support	Principals of Information Technology	Business Information Management I or Banking/Money Matters	Accounting 1	Business Information Management II
	Financial Management & Support		Sports/Fashion Marketing	Marketing Dynamics	Career Prep
Information Technology Endorsement: Business & Industry	Information Technology	Principals of Information Technology	Computer Programing	Advanced Computer Programing	Research in IT Solutions
Health Science Endorsement: Public Service	Health Science	Principles of Health Science/Medical Terminology	Health Science	Practicum In HS CNA Practicum in Pharmacy Tech	Anatomy & Physiology Practicum In HS CAN/ Practicum in Pharmacy Tech <i>*not taken the previous year</i>
Hospitality & Tourism Endorsement: Business & Industry	Travel & Tourism	Principals of Hospitality & Tourism	Hotel Management/Travel & Tourism Management	Hospitality Services	Practicum in Hospitality Services
	Restaurants & Food/Beverage Services		Restaurant Management	Culinary Arts (Double Block)	Practicum in Culinary Arts (Double Block)
Law, Public Safety, Corrections & Security Endorsement: Public Service	Law Enforcement	Principals of Law, Public Safety, Corrections & Security	Law Enforcement I	Forensic Science	Law Enforcement II
Science Technology, Engineering & Mathematics Endorsement: STEM	Engineering	Concepts of Engineering & Technology	Engineering Design & Presentation (Electronics)	Advanced Engineering Design & Presentation (Robotics)	Engineering Design & Problem Solving

CANUTILLO HIGH SCHOOL

Board of Trustees

Executive Summary of Board Agenda Item

Meeting Date: _____
Agenda Item No.: _____

Subject/Title for Agenda Posting:

Justification Statement:

Purpose of Agenda Item: Action Information Discussion
Committee Meeting: Policy/Instruction/Personnel/Student Services Committee
 Finance/Audit/Facilities/Planning Committee Meeting

Staff Responsible:

Presenter(s)

Signature of Approval

Title

District Improvement Plan Objective, Goal or Need Addressed

RATIONALE:

RECOMMENDATION/MOTION:

FUNDING SOURCE:

ACCOUNT NO(S).

PROCUREMENT METHOD TYPE:

REQUESTING DEPARTMENT:

IMPACT ON OTHER FUNCTIONS/OPERATIONS:

CONSEQUENCES OF NON-APPROVAL:

IMPLEMENTATION TIMELINE:



Board of Trustees

Executive Summary of Board Agenda Item

Meeting Date: _____
Agenda Item No.: _____

Subject/Title for Agenda Posting: Budget Amendments for October 2014

Justification Statement: Enclosed are budget amendments for your review and consideration. The transfer requests have been reviewed for compliance and allowable uses.

Purpose of Agenda Item: Action Information Discussion
Committee Meeting: Policy/Instruction/Personnel/Student Services Committee
 Finance/Audit/Facilities/Planning Committee Meeting

Staff Responsible: Martha Aguirre

Presenter(s)

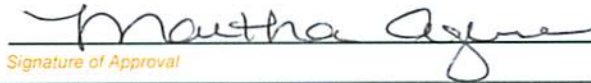

Signature of Approval

Title

District Improvement Plan Objective, Goal or Need Addressed

RATIONALE:

Refer to attached listing of budget amendments and their rationale.

RECOMMENDATION/MOTION:

Administration recommends the approval of budget amendments submitted for your consideration.

FUNDING SOURCE: Funds 185 & 199 ACCOUNT NO(S).

PROCUREMENT METHOD TYPE:

N/A

REQUESTING DEPARTMENT:

Financial Services Division on behalf of Curriculum & Instruction, Academic Language Services, Career & Technology Education, Davenport Elementary, and Garcia Elementary

IMPACT ON OTHER FUNCTIONS/OPERATIONS:

N/A

CONSEQUENCES OF NON-APPROVAL:

Activities planned will not occur.

IMPLEMENTATION TIMELINE:

N/A





TO: Board of Trustees
Dr. Pedro Galaviz, Superintendent

FROM: Martha Aguirre, Executive Director

DATE: September 30, 2014

SUBJECT: Budget Amendments for October 2014

Rationale for Budget Amendments Submitted:

BJE 19 - This budget amendment is to reallocate funds from function 11 to function 13 to provide campus teachers with opportunities to attend the National Council of Teachers of Mathematics 2014 Regional Conference in Houston, Texas on November 19-21, 2014. The fund allocations will provide travel funding.

BJE 324319 - This budget amendment is to reallocate funds from function 11 to function 13 to provide the faculty and staff with the opportunity to attend local professional development sessions throughout the school year. The fund allocations will provide registration fee funding.

BJE 324929 - This budget amendment is to reallocate funds from function 81 to function 11 to provide CTE students the opportunity to experience real world experiences in the work field. The allocations will provide funding to compensate CTE students for work performed within the District Departments.

BJE 326288 - This budget amendment is to reallocate funds from function 11 to function 13 & 21 to provide the C&I staff with opportunities to attend a Math RTI Regional Conference in Houston, Texas on November 19-21, 2014. The fund allocations will provide funding for travel expenses.

BJE 327212 - This budget amendment is to reallocate funds from function 81 to function 11 to provide CTE students the opportunity to experience real world experiences in the work field. The allocations will provide funding to compensate CTE students for work performed within the District Departments.

BJE 327299 - This budget amendment is to reallocate funds from function 81 to function 11 to provide the CTE teachers with the opportunity to attend the professional development sessions in order to meet the needs of the CTE Department. The fund allocations will provide funding for substitutes during the 2014-2015 school year.

BJE 327734 - This budget amendment is to reallocate funds from function 81 to function 31 to provide the CTE Counselors with the opportunity to attend the School Counselor Academy and other professional development training opportunities. The fund allocations will provide funding for the travel expenses and registration fees.

BJE 328639 - This budget amendment is to reallocate funds from function 23 to function 13 to provide the faculty and staff with the opportunity to attend the Texas Bully Prevention Summit 2014. The fund allocations will provide travel expense funding for costs not covered with federal funding.

BJE 329371 - This budget amendment is to reallocate funds from function 81 to function 53 to provide the CTE IT Technician with the opportunity to attend the professional development sessions in order to meet the needs of the CTE Department. The fund allocations will provide funding for travel expenses.



BJE 330314 - This budget amendment is to reallocate funds from function 13 to function 21 to provide the Special Education Director the opportunity to attend the National Council of Teachers Mathematics 2014 Regional Conference. The allocation will provide funding for travel expenses.

BJE 330553 - This budget amendment is to reallocate funds from function 13 to function 11 to provide CES K-2 teachers the opportunity to attend the Dual Language Institute. The fund allocations will provide substitute pay.

BJE 330554 - This budget amendment is to reallocate funds from function 81 to function 11 to cover the tuition costs of the CTE students' participation in the EPISD CTE Program. The fund allocation will pay tuition fees.

BJE 330562 - This budget amendment is to reallocate funds from function 11 to function 13 to provide campus teachers and instructional coaches with opportunities to attend the National Council of Teachers of Mathematics 2014 Regional Conference in Houston, Texas on November 19-21, 2014. The fund allocations will provide funding for travel expenses.

BJE 330570 - This budget amendment is to reallocate funds from function 23 to function 13 to provide the faculty and staff with the opportunity to attend the STAAR Writing Workshop. The fund allocations will provide travel expense funding for costs not covered with federal funding.

BJE 330587 - This budget amendment is to reallocate funds from function 11 to function 41 to provide funding for the Chief Financial Officer's salary allocation for the 2014-2015 schoolyear.

TO: Board of Trustees
 Dr. Pedro Galaviz, Superintendent

FROM: Martha Aguirre, Executive Director

DATE: September 30, 2014

SUBJECT: BJE #19 - Garcia Elementary

BUDGET ACCOUNT NUMBER	CURRENT BUDGET	CHANGE	AMENDED BUDGET
185.11.6399.00.105.5.30 General Supplies	\$ 24,928.00	\$ (1,900.00)	\$ 23,028.00
185.13.6411.00.105.5.30 Travel - Employee	\$ -	\$ 1,900.00	\$ 1,900.00

Diff \$ -

Amendment Request Justification:

This budget amendment is to reallocate funds from function 11 to function 13 to provide campus teachers with opportunities to attend the National Council of Teachers of Mathematics 2014 Regional Conference in Houston, Texas on November 19-21, 2014. The fund allocations will provide travel funding.

Martha Aguirre
 Martha Aguirre, Executive Director of Financial Services

9/30/14
 Date





MaintainBudgetChangeRequest.jsp

iscal Year: 2015

Import Budget Change

Request ID: 19

Date: * 09-24-2014

Description: * Mathematics Regional Conference Houston

Justification: * 2014 Regional Conference November 19-21, 2014 Houston Texas

Characters remaining: 362 (500 max)

Amount: 50.00

Unreconciled Amount: 50.00

Decrease Accounts

Account	Balance	Amount	Percentage
185 . 11 . 6399 . 00 . 105 . 30 . 2015 . 105	\$24,928.00	\$1,900.00	100.00000%

\$1,900.00 100.00000%

Auto Complete: on

Increase Accounts

Account	Balance	Amount	Percentage
185 . 13 . 6411 . 00 . 105 . 30 . 2015 . 105	\$0.00	\$1,900.00	100.00000%

\$1,900.00 100.00000%

Auto Complete: on

2.1.8
 GES Teacher will attend the National Council of Teachers of Mathematics 2014 Regional Conference November 19-21, 2014 Houston Texas

Characters remaining: 362 (500 max)

Jangela J. Carter
09/24/14

RCVD SEP 24 2014 PM 12:09

TO: Board of Trustees
 Dr. Pedro Galaviz, Superintendent

FROM: Martha Aguirre, Executive Director

DATE: September 30, 2014

SUBJECT: BJE #324319 - Davenport Elementary

BUDGET ACCOUNT NUMBER	CURRENT BUDGET	CHANGE	AMENDED BUDGET
199.11.6499.00.102.5.11 Misc. Operating Costs	\$ 2,000.00	\$ (1,000.00)	\$ 1,000.00
199.13.6499.00.102.5.11 Misc. Operating Costs	\$ -	\$ 1,000.00	\$ 1,000.00

Diff \$ -

Amendment Request Justification:

This budget amendment is to reallocate funds from function 11 to function 13 to provide the faculty and staff with the opportunity to attend local professional development sessions throughout the school year. The fund allocations will provide registration fee funding.

Martha Aguirre
 Martha Aguirre, Executive Director of Financial Services

9/30/14
 Date





MaintainBudgetChangeRequest.jsp

Fiscal Year: 2015 Request Description: DDE - STAFF DEVELOPMENT

Budget Change Requests History Import Budget Change

Project Change Request Details

Request ID: 324319

Date: * 09-03-2014

Description: * DDE - STAFF DEVELOPMENT

Justification: * GOAL 4. Objective 2. Characters remaining: 327 (500 max)

Amount: \$1,000.00
Unreconciled Amount: \$0.00

Decrease Accounts		
Account	Balance Amount	Percentage
199.11.6499.00.102.11.2015.102	\$920.00	100.00000%
<input checked="" type="checkbox"/>	\$1,000.00	100.00000%
Auto Complete: on		

Increase Accounts		
Account	Balance Amount	Percentage
199.13.6499.00.102.11.2015.102	\$0.00	100.00000%
<input checked="" type="checkbox"/>	\$1,000.00	100.00000%
Auto Complete: on		

Editor

GOAL 4. Objective 2. To provide the opportunity for faculty and staff to attend to different trainings throughout the school year 2014-2015. At Region 19 or other venues.

[Handwritten Signature] 9/9/14

Characters remaining: 327 (500 max)

Attachments

TO: Board of Trustees
 Dr. Pedro Galaviz, Superintendent

FROM: Martha Aguirre, Executive Director

DATE: September 30, 2014

SUBJECT: BJE #324929 - Career & Technology Education

BUDGET ACCOUNT NUMBER	CURRENT BUDGET	CHANGE	AMENDED BUDGET
199.81.6629.00.917.5.22 Building Purchase, Construction or Improvements	\$ 76,104.00	\$ (3,656.00)	\$ 72,448.00
199.11.6126.03.917.5.22 Part Time/Temp Pay - CTE Students	\$ 7,645.00	\$ 3,576.00	\$ 11,221.00
199.11.6141.03.917.5.22 Medicare	\$ 186.00	\$ 52.00	\$ 238.00
199.11.6143.03.917.5.22 Workers Compensation	\$ 75.00	\$ 21.00	\$ 96.00
199.11.6145.03.917.5.22 Unemployment	\$ 75.00	\$ 7.00	\$ 82.00

Diff \$ -

Amendment Request Justification:

This budget amendment is to reallocate funds from function 81 to function 11 to provide CTE students the opportunity to experience real world experiences in the work field. The allocations will provide funding to compensate CTE students for work performed within the District Departments.

Martha Aguirre
 Martha Aguirre, Executive Director of Financial Services

9/30/14
 Date



Fiscal Year: 2015 Request Description: CTE - Part Time Students

Import Budget Change

Request ID: 324929 Amount: \$3,655.00
Date: * 09-04-2014 Unreconciled Amount: \$0.00

Description: * CTE - Part Time Students

Justification: * CTE will pay the salary of 3 CTE part time students.
Characters remaining: 429 (500 max)

Decrease Accounts

Account	Balance	Amount	Percentage
199 .81 .6629 .00 .917 .22 .2015 .917	\$29,252.56	\$3,655.00	100.00000%

\$3,655.00 100.00%

Auto Complete: on

Increase Accounts

Account	Balance	Amount	Percentage
199 .11 .6126 .03 .917 .22 .2015 .917	\$7,645.00	\$3,121.00	85.3899%

~~+99 .11 .6143 .03 .917 .22 .2015 .917~~ \$75.00 ~~\$534.00~~ 14.6101%

\$3,655.00 100.00%

Auto Complete: on

Revise w/ correct amounts -

CTE will pay the salary of 3 CTE part time students.

Goal 2
Jan Massie

Jan Massie

Characters remaining: 429 (500 max)

Save Cancel

TO: Board of Trustees
 Dr. Pedro Galaviz, Superintendent

FROM: Martha Aguirre, Executive Director

DATE: September 30, 2014

SUBJECT: BJE #326288 - Curriculum & Instruction

BUDGET ACCOUNT NUMBER	CURRENT BUDGET	CHANGE	AMENDED BUDGET
185.11.6299.00.916.5.30 Misc. Contracted Services	\$ 40,000.00	\$ (3,600.00)	\$ 36,400.00
185.13.6411.00.916.5.30 Travel - Employee	\$ -	\$ 1,550.00	\$ 1,550.00
185.21.6411.00.916.5.30 Travel - Employee	\$ -	\$ 2,050.00	\$ 2,050.00

Diff \$ -

Amendment Request Justification:

This budget amendment is to reallocate funds from function 11 to function 13 & 21 to provide C&I staff with opportunities to attend a Math RTI Regional Conference in Houston, Texas on November 19-21, 2014. The fund allocations will provide funding for travel expenses.

Martha Aguirre
 Martha Aguirre, Executive Director of Financial Services

9/30/14
 Date

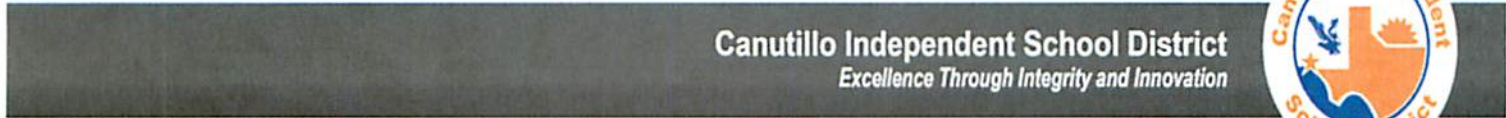



MaintainBudgetChangeRequest.jsp
Zoom: 200%

Fiscal Year: 2015 Request Description: C & I - Travel

Budget Change Requests History Import Budget Change

Budget Change Request Details

Request ID: 326288
 Date: 09-09-2014
 Description: * C & I - Travel
 Justification: * G:2 O:1 S:14 - Provide Curriculum and Instruction Executive
 Characters remaining: 294 (500 max)

Amount: \$3,600.00
Unreconciled Amount: \$0.00

Decrease Accounts

Account	Balance	Amount	Percentage
185.11.6299.00.916.30.2015.916	\$9,130.10	\$3,600.00	100.0000%
			\$3,600.00 100.0000%

Auto Complete: on

Increase Accounts

Account	Balance	Amount	Percentage
185.13.6411.00.916.30.2015.916	\$0.00	\$1,550.00	43.0556%
185.21.6411.00.916.24.2015.916	\$0.00	\$2,050.00	56.9444%
			\$3,600.00 100.0000%

Auto Complete: on

Editor

G:2 O:1 S:14 - Provide Curriculum and Instruction Executive Director and Math District Instructional Coordinator with travel funds to attend a Math RTI Regional Conference at Houston on November 19-21, 2014.

Characters remaining: 294 (500 max)

Attachments

116

APPROVED

Auzuniga

Date 9-10-14
9-15-14

TO: Board of Trustees
 Dr. Pedro Galaviz, Superintendent

FROM: Martha Aguirre, Executive Director

DATE: September 30, 2014

SUBJECT: BJE #327212 - Career & Technology Education

BUDGET ACCOUNT NUMBER		CURRENT BUDGET	CHANGE	AMENDED BUDGET
199.81.6629.00.917.5.22	Building Purchase, Construction or Improvements	\$ 76,104.00	\$ (1,872.00)	\$ 74,232.00
199.11.6126.03.917.5.22	Part Time/Temp Pay - CTE Students	\$ 7,645.00	\$ 1,830.00	\$ 9,475.00
199.11.6141.03.917.5.22	Medicare	\$ 186.00	\$ 27.00	\$ 213.00
199.11.6143.03.917.5.22	Workers Compensation	\$ 75.00	\$ 11.00	\$ 86.00
199.11.6145.03.917.5.22	Unemployment	\$ 75.00	\$ 4.00	\$ 79.00

Diff \$ -

Amendment Request Justification:

This budget amendment is to reallocate funds from function 81 to function 11 to provide CTE students the opportunity to experience real world experiences in the work field. The allocations will provide funding to compensate CTE students for work performed within the District Departments.

Martha Aguirre

Martha Aguirre, Executive Director of Financial Services

9/30/14

Date



Fiscal Year: 2015

Import Budget Change

Budget Change Request Details

Request ID: 327212
 Date: * 09-10-2014
 Description: * CTE - Tutors
 Justification: * CTE will hire 2 tutors to assist with CTE HS students.
 Characters remaining: 427 (500 max)

Amount: \$0.00
 Unreconciled Amount: \$0.00

Decrease Accounts

Account	Balance	Amount	Percentage
199 . 81 . 6629 . 00 . 917 . 22 . 2015 . 917	\$25,597.56	\$1,870.00	100.0000%
		<i>\$1872</i>	\$1,870.00 100.0000%



Auto Complete: on

Increase Accounts

Account	Balance	Amount	Percentage
199 . 11 . 6126 . 03 . 917 . 22 . 2015 . 917	\$7,645.00	\$1,870.00	100.0000%
		\$1,870.00 100.0000%	



Auto Complete: on

CTE will hire 2 tutors to assist with CTE HS students.
 Goal 2
 Jan Massie

Characters remaining: 427 (500 max)

TO: Board of Trustees
 Dr. Pedro Galaviz, Superintendent

FROM: Martha Aguirre, Executive Director

DATE: September 30, 2014

SUBJECT: BJE #327299 - Career and Technology Education

BUDGET ACCOUNT NUMBER		CURRENT BUDGET	CHANGE	AMENDED BUDGET
199.81.6629.00.917.5.22	Building Purchase, Construction or Improvements	\$ 76,104.00	\$ (5,001.00)	\$ 71,103.00
199.11.6112.13.917.5.22	Substitutes - Staff Dev.	\$ 3,000.00	\$ 4,892.00	\$ 7,892.00
199.11.6141.13.917.5.22	Medicare	\$ -	\$ 71.00	\$ 71.00
199.11.6143.13.917.5.22	Workers Compensation	\$ -	\$ 29.00	\$ 29.00
199.11.6145.13.917.5.22	Unemployment	\$ -	\$ 9.00	\$ 9.00

Diff \$ -

Amendment Request Justification:

This budget amendment is to reallocate funds from function 81 to function 11 to provide the CTE teachers with the opportunity to attend the professional development sessions in order to meet the needs of the CTE Department. The fund allocations will provide funding for substitutes during the 2014-2015 school year.

Martha Aguirre
 Martha Aguirre, Executive Director of Financial Services

9/30/14
 Date



Fiscal Year: 2015

Import Budget Change

Request ID: 327299

Date: * 09-10-2014

Description: * CTE - Substitutes

Justification: * To pay for CTE teacher substitutes during school year 2014-2015

Characters remaining: 418 (500 max)

Amount: \$0.00

Unreconciled Amount: \$0.00

Decrease Accounts

Account	Balance	Amount	Percentage
199 . 81 . 6629 . 00 . 917 . 22 . 2015 . 917	\$25,597.56	\$5,000.00	100.00000%

Auto Complete: on

+ \$5,000.00 100.00000%

Increase Accounts

Account	Balance	Amount	Percentage
199 . 11 . 6112 . 00 . 917 . 22 . 2015 . 917	\$7,827.00	\$5,000.00	100.00000%

Auto Complete: on

+ \$5,000.00 100.00000%

Editor

To pay for CTE teacher substitutes during school year 2014-2015

Goal 2

Jan Massie

Characters remaining: 418 (500 max)

Save Cancel

TO: Board of Trustees
 Dr. Pedro Galaviz, Superintendent

FROM: Martha Aguirre, Executive Director

DATE: September 30, 2014

SUBJECT: BJE #327734 - Career and Technology Education

BUDGET ACCOUNT NUMBER	CURRENT BUDGET	CHANGE	AMENDED BUDGET
199.81.6629.00.917.5.22 Building Purchase, Construction or Improvements	\$ 76,104.00	\$ (5,000.00)	\$ 71,104.00
199.31.6411.00.917.5.22 Travel - Employee	\$ 2,500.00	\$ 5,000.00	\$ 7,500.00

Diff \$ -

Amendment Request Justification:

This budget amendment is to reallocate funds from function 81 to function 31 to provide the CTE Counselors with the opportunity to attend the School Counselor Academy and other professional development training opportunities. The fund allocations will provide funding for the travel expenses and registration fees.

Martha Aguirre
 Martha Aguirre, Executive Director of Financial Services

9/30/14
 Date

Fiscal Year: 2015

Import Budget Change

Budget Change Request # 327734

Request ID: 327734
 Date: * 09-12-2014
 Description: * CTE - Counselor Travel
 and other trainings
 Justification: * Goal 2
 Characters remaining: 406 (500 max)

Amount: \$0.00
 Unreconciled Amount: \$0.00

Decrease Accounts

Account	Balance	Amount	Percentage
199 . 81 . 6629 . 00 . 917 . 22 . 2015 . 917	\$60,952.56	\$5,000.00	100.0000%
		\$5,000.00	100.0000%



Auto Complete: on

Increase Accounts

Account	Balance	Amount	Percentage
199 . 31 . 6411 . 00 . 917 . 22 . 2015 . 917	\$1,931.61	\$5,000.00	100.0000%
		\$5,000.00	100.0000%



Auto Complete: on

Comments

The CTE Counselors will attend the 2014-15 School Counselor Academy and other trainings.
Goal 2

Jan Myer

Characters remaining: 405 (500 max)

122

TO: Board of Trustees
 Dr. Pedro Galaviz, Superintendent

FROM: Martha Aguirre, Executive Director

DATE: September 30, 2014

SUBJECT: BJE #328639 - Davenport Elementary

BUDGET ACCOUNT NUMBER	CURRENT BUDGET	CHANGE	AMENDED BUDGET
199.23.6411.00.102.5.99 Travel - Employee	\$ 3,300.00	\$ (200.00)	\$ 3,100.00
199.13.6411.00.102.5.11 Travel - Employee	\$ -	\$ 200.00	\$ 200.00

Diff \$ -

Amendment Request Justification:

This budget amendment is to reallocate funds from function 23 to function 13 to provide the faculty and staff with the opportunity to attend the Texas Bully Prevention Summit 2014. The fund allocations will provide travel expense funding for costs not covered with federal funding.

Martha Aguirre
 Martha Aguirre, Executive Director of Financial Services

9/30/14
 Date



TO: Board of Trustees
 Dr. Pedro Galaviz, Superintendent

FROM: Martha Aguirre, Executive Director

DATE: September 30, 2014

SUBJECT: BJE #329371 - Career and Technology Education

BUDGET ACCOUNT NUMBER	CURRENT BUDGET	CHANGE	AMENDED BUDGET
199.81.6629.00.917.5.22 Building Purchase, Construction or Improvements	\$ 76,104.00	\$ (6,000.00)	\$ 70,104.00
199.53.6411.00.728.5.22 Travel - Employee	\$ -	\$ 6,000.00	\$ 6,000.00

Diff \$ -

Amendment Request Justification:

This budget amendment is to reallocate funds from function 81 to function 53 to provide the CTE IT Technician with the opportunity to attend the professional development sessions in order to meet the needs of the CTE Department. The fund allocations will provide travel funding.

Martha Aguirre
 Martha Aguirre, Executive Director of Financial Services

9/30/14
 Date

Fiscal Year: 2015 Request Description: CTE - IT Tech Travel

Import Budget Change

Request Change Request Details

Request ID: 329371
 Date: * 09-17-2014
 Description: * CTE - IT Tech Travel
 Justification: * CTE IT Tech. will attend various training to meet the needs of the CTE
 Characters remaining: 410 (500 max)

Amount: \$6,000.00
 Unreconciled Amount: \$0.00

Decrease Accounts

Account	Balance	Amount	Percentage
199 . 81 . 6629 . 00 . 917 . 22 . 2015 . 917	\$50,952.56	\$6,000.00	100.0000%
		\$6,000.00	100.0000%

Auto Complete: on

Increase Accounts

Account	Balance	Amount	Percentage
199 . 53 . 6411 . 00 . 728 . 22 . 2015 . 917	\$0.00	\$6,000.00	100.0000%
		\$6,000.00	100.0000%

Auto Complete: on

CTE IT Tech. will attend various training to meet the needs of the CTE Department.
 Goal 2



Characters remaining: 410 (500 max)

TO: Board of Trustees
 Dr. Pedro Galaviz, Superintendent

FROM: Martha Aguirre, Executive Director

DATE: September 30, 2014

SUBJECT: BJE #330314 - Special Education Department

BUDGET ACCOUNT NUMBER	CURRENT BUDGET	CHANGE	AMENDED BUDGET
185.13.6411.35.918.5.30 Travel - Employee	\$ 7,000.00	\$ (2,000.00)	\$ 5,000.00
185.21.6411.35.918.5.24 Travel - Employee	\$ -	\$ 2,000.00	\$ 2,000.00

Diff \$ -

Amendment Request Justification:

This budget amendment is to reallocate funds from function 13 to function 21 to provide the Special Education Director the opportunity to attend the National Council of Teachers Mathematics 2014 Regional Conference. The allocation will provide funding for travel expenses.

 Martha Aguirre, Executive Director of Financial Services

10/2/14
 Date





MaintainBudgetChangeRequest.jsp

Fiscal Year: 2015

Budget Change Requests History Import Budget Change

Budget Change Request Details

Request ID: 330314

Date: 09-19-2014

Description: * SPED GOAL 2

Justification: * Budget transfer for SPED Director to attend National Mathematics 2014 Regional Conference and Exposition (Rt)

Characters remaining: 367 (500 max)

Amount: \$0.00

Unreconciled Amount: \$0.00

Decrease Accounts

Account	Fund	Fnc	Obj	Sub	Org	Plc	Year	Owner	Balance	Amount	Percentage
185	13	6411	35	918	30	2015	918		\$7,000.00	2000	100.00000%
										\$0.00	100.00000%

Auto Complete: on

Increase Accounts

Account	Fund	Fnc	Obj	Sub	Org	Plc	Year	Owner	Balance	Amount	Percentage
185	21	6411	35	918	24	2015	918		\$0.00	2000	100.00000%
										\$0.00	100.00000%

Auto Complete: on

Editor

Budget transfer for SPED Director to attend National Council of Teachers Mathematics 2014 Regional Conference and Exposition (Rt)

Characters remaining: 370 (500 max)

Carly Chen 9/17/14

Amy Ziminger 9/20/14

(Requires board approval)

PCUD SEP 19 2014 AM 08:35

TO: Board of Trustees
 Dr. Pedro Galaviz, Superintendent

FROM: Martha Aguirre, Executive Director

DATE: September 30, 2014

SUBJECT: BJE #330553 - Academic Language Services

BUDGET ACCOUNT NUMBER	CURRENT BUDGET	CHANGE	AMENDED BUDGET
199.13.6411.00.919.5.25 Travel - Employee	\$ 16,500.00	\$ (4,001.00)	\$ 12,499.00
199.11.6112.13.917.5.25 Substitutes - Staff Dev.	\$ 3,932.00	\$ 3,914.00	\$ 7,846.00
199.11.6141.13.917.5.25 Medicare	\$ 44.00	\$ 57.00	\$ 101.00
199.11.6143.13.917.5.25 Workers Compensation	\$ 18.00	\$ 23.00	\$ 41.00
199.11.6145.13.917.5.25 Unemployment	\$ 6.00	\$ 7.00	\$ 13.00

Diff \$ -

Amendment Request Justification:

This budget amendment is to reallocate funds from function 13 to function 11 to provide CES K-2 teachers the opportunity to attend the Dual Language Institute . The fund allocations will provide substitute pay.

Martha Aguirre
 Martha Aguirre, Executive Director of Financial Services

9/30/14
 Date





MaintainBudgetChangeRequest.jsp
Zoom: 115%

Fiscal Year: 2015

Budget Change Requests History Import Budget Change

Budget Change Request Details

Request ID: 330553
 Date: 09-24-2014
 Description: * ALS - Substitute pay for Dual Language Instl
 Justification: * Transfer of State Bilingual Funds to cover substitute pay for CES K-2nd grade teachers while attending the Dual Language Institute.
 Characters remaining: 338 (500 max)

Amount: \$0.00
 Unreconciled Amount: \$0.00

Decrease Accounts

Account	Balance	Amount	Percentage
199.13.6411.00.919.25.2015.919	\$16,500.00	\$4,000.00	100.00000%
Auto Complete: on			

41001

Increase Accounts

Account	Balance	Amount	Percentage
199.11.6112.13.919.25.2015.919	\$3,932.00	\$4,000.00	100.00000%
Auto Complete: on			

fringe costs pending

Editor

Transfer of State Bilingual Funds to cover substitute pay for CES K-2nd grade teachers while attending the Dual Language Institute.

Goal/Obj/Strategy: 2.12.5

Characters remaining: 338 (500 max)

9/24/2014

Dr. [Signature]

Attachments

TO: Board of Trustees
 Dr. Pedro Galaviz, Superintendent

FROM: Martha Aguirre, Executive Director

DATE: September 30, 2014

SUBJECT: BJE #330554 - Career and Technology Education

BUDGET ACCOUNT NUMBER	CURRENT BUDGET	CHANGE	AMENDED BUDGET
199.81.6629.00.917.5.22 Building Purchase, Construction or Improvements	\$ 76,104.00	\$ (29,000.00)	\$ 47,104.00
199.11.6229.00.917.5.22 Tuition/Transfer Payments	\$ 35,000.00	\$ 29,000.00	\$ 64,000.00

Diff \$ -

Amendment Request Justification:

This budget amendment is to reallocate funds from function 81 to function 11 to cover the tuition costs of the CTE students' participation in the EPISD CTE program.

 Martha Aguirre, Executive Director of Financial Services

 Date



Fiscal Year: 2015

Import Budget Change

Budget Change Account Details

Request ID: 330554 Amount: \$0.00
 Date: * 09-25-2014 Unreconciled Amount: \$0.00
 Description: * CTE - CTE
 Justification: * Student CTE Tuition
 2.1.2
 Characters remaining: 474 (500 max)

Decrease Accounts

Account	Balance	Amount	Percentage
199 . 81 . 6629 . 00 . 917 . 22 . 2015 . 917	\$44,952.56	\$29,000.00	100.0000%
		\$29,000.00	100.0000%

Auto Complete: on

Increase Accounts

Account	Balance	Amount	Percentage
199 . 11 . 6229 . 00 . 917 . 22 . 2015 . 917	\$0.00	\$29,000.00	100.0000%
		\$29,000.00	100.0000%

Auto Complete: on

Student CTE Tuition
 2.1.2
 Characters remaining: 474 (500 max)
 Save Cancel

Handwritten signature

132

TO: Board of Trustees
 Dr. Pedro Galaviz, Superintendent

FROM: Martha Aguirre, Executive Director

DATE: September 30, 2014

SUBJECT: BJE #330562 - Curriculum & Instruction

BUDGET ACCOUNT NUMBER	CURRENT BUDGET	CHANGE	AMENDED BUDGET
185.11.6299.00.916.5.30 Misc. Contracted Services	\$ 40,000.00	\$ (5,530.00)	\$ 34,470.00
185.11.6399.40.916.5.30 General Supplies - SS	\$ 36,000.00	\$ (11,000.00)	\$ 25,000.00
185.13.6411.00.105.5.30 Travel - Employee	\$ -	\$ 16,530.00	\$ 16,530.00

Diff \$ -

Amendment Request Justification:

This budget amendment is to reallocate funds from function 11 to function 13 to provide campus teachers and instructional coaches with opportunities to attend the National Council of Teachers of Mathematics 2014 Regional Conference in Houston, Texas on November 19-21, 2014. The fund allocations will provide funding for travel expenses.

Martha Aguirre

Martha Aguirre, Executive Director of Financial Services

9/30/14
 Date





MaintainBudgetChangeRequest.jsp
Zoom: 200%

Fiscal Year: 2015 Request Description: C & I - RTI travel for teachers & ICs

Budget Change Requests History Import Budget Change

Budget Change Request Details

Request ID: 330562
 Date: 09-29-2014
 Description: * C & I - RTI travel for teachers & ICs
 Justification: * 2.1.14 Provide Campus teachers and ICs with SCE travel funds to
 Characters remaining: (500 max)

Amount: \$16,530.00
 Unreconciled Amount: \$0.00

Decrease Accounts						
Account	Balance	Amount	Percentage			
185.11.6299.00.916.30.2015.916	\$5,530.10	\$5,530.00	33.4543%			
185.11.6399.40.916.30.2015.916	\$36,000.00	\$11,000.00	66.5457%			
					\$16,530.00	100.0000%

Auto Complete: on

Increase Accounts						
Account	Balance	Amount	Percentage			
185.13.6411.00.916.30.2015.916	\$0.00	\$16,530.00	100.0000%			
					\$16,530.00	100.0000%

Auto Complete: on

Editor

2.1.14 Provide Campus teachers and ICs with SCE travel funds to attend a math RTI Regional Conference at Houston on November 19-21, 2014.

Characters remaining: (500 max)

134

Attachments

APPROVED

 Anne Z.

Date 9-29-14
 10-2-14

TO: Board of Trustees
 Dr. Pedro Galaviz, Superintendent

FROM: Martha Aguirre, Executive Director

DATE: September 30, 2014

SUBJECT: BJE #330570 - Davenport Elementary

BUDGET ACCOUNT NUMBER	CURRENT BUDGET	CHANGE	AMENDED BUDGET
199.23.6411.00.102.5.99 Travel - Employee	\$ 3,300.00	\$ (300.00)	\$ 3,000.00
199.13.6411.00.102.5.11 Travel - Employee	\$ -	\$ 300.00	\$ 300.00

Diff \$ -

Amendment Request Justification:

This budget amendment is to reallocate funds from function 23 to function 13 to provide the faculty and staff with the opportunity to attend the STAAR Writing Workshop. The fund allocations will provide travel expense funding for costs not covered with federal funding.

 Martha Aguirre, Executive Director of Financial Services

 Date



Maintain Budget Change Request -

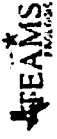

MaintainBudgetChangeRequest.jsp

Request Description: DDE - Staff Development Travel

Fiscal Year: 2015

Budget Change Requests History Import Budget Change

Request ID: 330570
Date: 09-29-2014
Description: DDE - Staff Development Travel
Justification: Goal 1, Objective 4
Characters remaining: (500 max)

Amount: \$300.00
Unreconciled Amount: \$0.00

Decrease Accounts		
Account	Balance	Amount Percentage
199.23.6411.00.102.99.2015.102	\$3,018.09	\$300.00 100.00000%
Auto Complete: on		

Increase Accounts		
Account	Balance	Amount Percentage
199.13.6411.00.102.11.2015.102	\$0.00	\$300.00 100.00000%
Auto Complete: on		

Goal 1:
Objective 4:
To cover extra expenses not covered by federal accounts used in travel request.
STAAR Writing Workshop in San Antonio

Characters remaining: (500 max)

*Alone
9/29/14
mll*

TO: Board of Trustees
 Dr. Pedro Galaviz, Superintendent

FROM: Martha Aguirre, Executive Director

DATE: September 30, 2014

SUBJECT: BJE # 330587 - Financial Services Division

BUDGET ACCOUNT NUMBER	CURRENT BUDGET	CHANGE	AMENDED BUDGET
199.11.6118.00.999.5.11 Salaries - PEZ	\$ 275,000.00	\$ (18,171.00)	\$ 256,829.00
199.41.6142.00.727.5.99 Healthcare	\$ 73,786.00	\$ (3,690.00)	\$ 70,096.00
199.41.6119.00.734.5.99 Salaries	\$ -	\$ 16,932.00	\$ 16,932.00
199.41.6141.00.734.5.99 Medicare	\$ -	\$ 246.00	\$ 246.00
199.41.6143.00.734.5.99 Workers Compensation	\$ -	\$ 98.00	\$ 98.00
199.41.6145.00.734.5.99 Unemployment	\$ -	\$ 28.00	\$ 28.00
199.41.6146.00.734.5.99 TRS	\$ -	\$ 867.00	\$ 867.00
199.41.6142.00.734.5.99 Healthcare	\$ -	\$ 3,690.00	\$ 3,690.00

Diff \$ -

Amendment Request Justification:

This budget amendment is to reallocate funds from function 11 to function 41 to provide funding for the Chief Financial Officer's salary allocation for the 2014-2015 school year.



 Martha Aguirre, Executive Director of Financial Services

10/1/14
 Date





Fiscal Year: 2015

Import Budget Change

Budget Change Request Details

Request ID: **330587**

Date: * 10-02-2014

Description: * Finance - CFO Additional Funding

Justification: * To allocate additional funding required to cover the CFO position salary and benefits
 Characters remaining: 414 (500 max)

Amount: \$0.00

Unreconciled Amount: \$0.00

Decrease Accounts

Account	Balance	Amount	Percentage
199 . 11 . 6118 . 00 . 999 . 11 . 2015 . 999	\$275,000.00	\$18,171.00	100.0000%
199 . 41 . 6142 . 00 . 727 . 99 . 2015 . 000	\$60,059.04	\$3,690.00	0.0000%
			\$21,861.00 100.0000%

Auto Complete: on

Increase Accounts

Account	Balance	Amount	Percentage
199 . 41 . 6119 . 00 . 734 . 99 . 2015 . 000	\$0.00	\$16,932.00	100.0000%
199 . 41 . 6141 . 00 . 734 . 99 . 2015 . 000	\$0.00	\$246.00	0.0000%
199 . 41 . 6143 . 00 . 734 . 99 . 2015 . 000	\$0.00	\$98.00	0.0000%
199 . 41 . 6145 . 00 . 734 . 99 . 2015 . 000	\$0.00	\$28.00	0.0000%
199 . 41 . 6146 . 00 . 734 . 99 . 2015 . 000	\$0.00	\$867.00	0.0000%
199 . 41 . 6142 . 00 . 734 . 99 . 2015 . 000	\$0.00	\$3,690.00	0.0000%
			\$21,861.00 100.0000%

Auto Complete: on

Attachments

Editor

To allocate additional funding required to cover the CFO position salary and benefits.

Characters remaining: 414 (500 max)

Save Cancel

Paul S. [Signature] 10/2/14

138



TO: Board of Trustees
Dr. Pedro Galaviz, Superintendent

FROM: Martha Aguirre, Executive Director

DATE: October 7, 2014

SUBJECT: Additional Information Regarding Compliance Comment #5 - TEA Annual Financial & Compliance Report

On the Board Thursday Packet dated September 18, 2014 an update regarding a response to the letter received from the Texas Education Agency (TEA) dated July 11, 2014 was provided. The letter from the Division of Financial Compliance at the TEA indicated that as a result of the review of the District's annual financial and compliance report (ARF), it was determined that the District and its external auditors needed to provide responses to the items noted.

As stated in the update, all information requested was provided to TEA. An email was received from Ms. Gayle Escobedo, State Auditor, on Monday, September 15th indicating that the AFR Review was officially closed.

Subsequent to the update provided to the Board, a request was submitted for clarification regarding the TEA Annual Financial & Compliance Report, specifically item five under Division of Financial Compliance Comments.

Division of Financial Compliance Comments (Pg. 2 of 3)

5. Our review of the governmental funds balance sheet indicated that the district may not have included a state overallocation of \$556,181 indicated by the State Funding Division as of August 31, 2013, as a liability under unearned revenue or amounts due to other governments. Your district should check for any state overallocation at the close of the next fiscal year and include this amount as unearned revenue or as an amount due to other governments if applicable.

The comment indicated that the state overallocation in the amount of \$556,181 was not recorded accordingly in the financials. An adjustment was required in the amount noted above. The adjustment was posted to the Foundation School Program on September 9, 2013 but was not recorded in the general ledger. The entry should have been recorded as 'due to other governments'.

The amount in question is related to the 2012-2013 data. The original foundation allocation is based on the 'legislative payment estimate'; however as the PEIMS data is submitted through the year, the foundation allocation is modified. In reviewing the 2012-2013 Summary of Finances – Near Final Report dated October 3, 2013, it was noted that after the final Summer PEIMS Submission there was a reduction of Refined ADA in the amount of 156. The reduction was mainly attributed to a reduction in participation in the CTE Program, Bilingual Education Program, and Transportation Allotment.

If you have additional questions or concerns, feel free to contact me at your discretion.

Board of Trustees

Executive Summary of Board Agenda Item

Meeting Date: 10/15/2014
Agenda Item No.: _____

Subject/Title for Agenda Posting: Approval to Purchase Fresh Fruits and Vegetables, from Segovia's Distributing, Inc. utilizing Education Service Center (ESC) Region 19 Allied State Cooperative #14-7065

Justification Statement: Food and Produce are necessary to provide students District wide with nutritional meals.

Purpose of Agenda Item: Action Information Discussion and Recommendation
Committee Meeting: Policy/Instruction/Personnel/Student Services Committee
 Finance/Audit/Facilities/Planning Committee Meeting

Staff Responsible: Aida Salcedo and Vianey Garcia

Presenter(s)

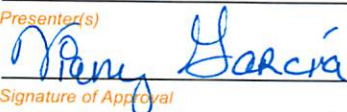

Signature of Approval

Purchasing Agent

Title

District Improvement Plan Objective, Goal or Need Addressed

RATIONALE:

Fresh fruits and vegetables will be purchased throughout the year to meet the needs of the Child Nutrition Program District wide for the 2014-2015 school year. The Food Service Department purchases fresh produce based on the meal standard requirements. The recommended approval amount is based on last year's purchases with an additional 10% to cover any price fluctuation.

As stated in Board Policy CH (Local), any purchase that costs or aggregates to a cost of \$10,000 or more shall require board approval before a transaction may take place.

RECOMMENDATION/MOTION:

It is recommended that the Board of Trustees approve the purchase of Fresh Fruits and Vegetables, from Segovia's Distributing, Inc., utilizing Education Service Center (ESC) Region 19 Allied State Cooperative #14-7065, in the amount not to exceed \$130,000.00.

ACCOUNT NO(S). 101.35.6341.00.909.99

PROCUREMENT METHOD TYPE:

ESC Region 19 Allied State Cooperative #14-7065

REQUESTING DEPARTMENT:

Food Service Department

CONSEQUENCES OF NON-APPROVAL:

Breakfast and lunch programs will not meet the nutritional needs of students District wide and the District could forfeit federal funding.

IMPLEMENTATION TIMELINE:

2014-2015 School Year

ATTACHMENT(S): ✓

ESC Region 19 Allied State Cooperative #14-7065 Award Information





Request for Board Agenda Item

Purchasing Department

Date: 9/16/2014

Campus/Department: Food and Nutrition Services

Vendor Name: Segovia's

Total Cost: \$130,000.00

Item Description and Justification for Purchase:

To purchase fruits and vegetables for the 2014 - 2015 school year.

Added a 10% cushion due to prices fluctuate

Participating Schools/Departments: All campuses

Funding Source: 101.35.6341.00.909.99

(Account number to charge)

[Signature]

Campus/Department Administrator

9/16/14

Date Signed

*** (Form must be received by the Purchasing Department by the last Wednesday of the month) ***

(To be completed by the Financial Services Division)

Purchasing Method: R19 Allied State Coop # 14-7065

[Signature]

Purchasing Agent

9/23/14

Date Signed

[Signature]

Executive Director of Financial Services

10/2/14

Date Signed

RCVD SEP 16 2014 PM 02:50

**EDUCATION SERVICE CENTER REGION 19
RFP AWARD SUMMARY**

RFQ TITLE: Produce Delivery and Related Services – ESC Region 19 Allied States Cooperative
RFP NUMBER: 14-7065
RFP OPENING DATE: August 22, 2014
CONTRACT TERM: Date of award until September 30, 2015 for a period of one (1) year with an option to renew annually for an additional four (4) years
FUNDING SOURCE: Various
RFP's ISSUED: 47
RESPONSES: 1
ADVERTISEMENT DATES: Washington Post - May 5, 2014 & May 12, 2014
BOARD MEETING DATE: October 16, 2014

RECOMMENDED FOR AWARD **Segovia's Distributing, Inc.**

TOTAL (estimated) **\$3,000,000.00 / year**

EXPLANATIONS:

Award of this contract will enable ESC-Region 19 and Region 19 Allied States Cooperative members to utilize delivery services from a qualified supplier for produce, rice, beans and egg delivery and related services in compliance with the State of Texas Education Code , section 44.042 . The sole bidder Segovia's Distributing, Inc. has a HACCP Product Recall Program, Quality Control Program, Food Safety Program and Third Party Inspected (NSF).

SPECIFICATIONS PROVIDED BY: Royce Cleveland
ESC Region 19 Allied States Cooperative

EVALUATION COMMITTEE: Royce Cleveland
ESC Region 19 Allied States Cooperative

Martin Camacho
ESC Region 19 Allied States Cooperative

Mary Jane Lopez
ESC Region 19 Allied States Cooperative

Contact Information

Segovia's Distributing, Inc.

Gabriel Segovia
3701 Shell St.
El Paso, TX 79925
915-533-3130
Fax: 915-577-0284

www.segoviasdistributinginc.com / ramoncarrera777@sbcglobal.net / gabriel.segovia@segoviasdistributinginc.com

Segovia's Distributing, Inc. – currently operates from two distributing facilities, one in El Paso, TX and the other one in Albuquerque, NM; we service more than 500 customers that include large restaurant chains, school districts, hospitals, large and small grocery stores, fruit stands and military installations. We service most of the New Mexico region and the Southwest of Texas.

Segovia's Distributing workforce consists of 120 employees ranging from truck drivers to upper management. 90% of our employees have 5 years of experience in the produce industry. We pride ourselves on following the HACCP system by, training our employees in all aspects of food safety.

Quality

Quality Control Program to assure customers get the best quality available.

Price – By having competitive prices we can assure the satisfaction of our customers.

Service – prompt delivery

Food Safety – The following programs have been implemented at our company to help us maintain our products quality; HACCP. Product Recall Program, Quality Control Program, Food Safety Program and Third Party Inspected (NSF)

On Line Web Ordering

Customer receives a confirmation, email and attachment

All orders electronically transmitted into Segovia's invoicing system

Order history available

Product usage reports and pricing is visible when ordering on-line.

www.segoviasdistributinginc.com

Pricing

Prices are effective from Monday to Saturday

Prices are updated Sunday and effective on Monday

Price sheets are available upon request to customer

Customer may request additional items to be added to Price Sheet

All items visible when ordering on-line

Pricing Formula

FOB + Freight Cost	=	Landed Cost
Landed Cost + Mark Up	=	Total Price
Total Price	=	Final Price

Split Case Pricing Formula

FOB + Freight Cost	=	Landed Cost
Landed Cost + Mark Up	=	Total Price
Total Price + Split Charge / No. of Splits	=	Total Price per Split
Total Price per Split	=	Final Price

Delivery Days

Delivery Days will be Monday, Wednesday, Friday and Saturday Only

All Orders must be placed a day prior and before 4:00 p.m.

No same day deliveries will be accepted

Emergency Delivery Orders (Same Day Delivery) will be accepted occasionally



Emergency Delivery Orders

Orders will be processed that same day but delivery will be performed based on the availability of delivery trucks at our shipping department.

Emergency Orders cannot be processed due to delivery trucks availability, time of call or day of the week, customers will be notified and order may be picked up at our facility.

"Will Call" orders are required to be picked up (1) hour after order was placed.

Reoccurring emergency orders will not be processed for delivery same day. Pick up of produce can be arranged as a "will call" order.

Note – delivery window for each account will be determined based on the location of the account and the desired delivery window requested. Segovia's will accommodate orders/routes to promptly service each requested delivery window.

Order Minimum Requirements

A minimum amount per order of \$75.00 is required

Orders that do not meet the \$75.00 minimum requirements can still be delivered

The cost to deliver an order less than \$75.00 will be \$15.00

Exception to the above: If the order is \$65.00 in total than customer will only be charged the difference which will be \$10.00.



Payment Terms

Payment terms are 30 days - due within 30 days of Delivery of Invoiced Product.

Invoice Adjustments and Credits

Invoice adjustments will be processed during time of delivery

Account representative or customer service must be notified during the adjustment of an invoice. Please do not make arrangements with drivers.

Copies of lost or misplaced invoices by customers can be faxed or emailed b request to our A/R Department, Customer Service or Sales Representative

Credit Memos

Will be processed only by our A/R and only with Sales Representative or Customer Service approval
Credit memos will be processed only within 24 hour s after delivery has been made

Note – If credit or exchange of product request by customer is not preformed within the 24 hour limit, customer will not be granted the option to have a re-delivery of product nor will a credit be issued.



Complaints & Special Requests

Complaints and/or special requests can be performed via email or phone.

- Name of person submitting complaint or special request
- Account number or address
- Date and time of incident or type of request
- Call back phone number

Complaint Department

Gabriel Segovia
 Office: 505-247-2997
 Cell: 915-253-8160
gabriel.segovia@segoviasdistributinginc.com

Customer Service Manager

Ramon Carrera
 Office: 505-247-2997
 Cell: 505-688-1356
ramon.carrera@segoviasdistributinginc.com



Contact vendor for more information

Service Area – New Mexico, Texas

Approved by: _____
 (Armando Aguirre – Executive Director)

Date: _____
 (August 3, 2014)





Purchasing Approval Sheet For Presentation to Board of Trustees Purchasing Department

Financial Services (Verification of Funding Availability and Account Coding)

Approved Denied

Comment: _____
Signature: Martha Aguiar Date: 10/2/14

Federal Programs (For Compliance with Grant Requirements)

Not Required Approved Denied

Comment: _____
Signature: _____ Date: _____

Curriculum & Instruction (For all Curriculum Related Purchases)

Not Required Approved Denied

Comment: _____
Signature: _____ Date: _____

Technology (For all Computer/Software/Peripheral Purchases)

Not Required Approved Denied

Comment: _____
Signature: _____ Date: _____

Legal Review

Not Required Approved Denied

Comment: _____
Signature: _____ Date: _____

Purchasing

Approved Denied

Comment: _____
Signature: Pam Garcia Date: 9/23/14

Board of Trustees

Executive Summary of Board Agenda Item

Meeting Date: 10/15/2014
Agenda Item No.: _____

Subject/Title for Agenda Posting: Award of Grease Trap Services to Valley By-Products Inc.

Justification Statement: To obtain a provider for grease trap services to be in compliance with the Rules and Regulations No.15 for governing the management of fats, oils and Greases (FOG).

Purpose of Agenda Item: Action Information Discussion and Recommendation
Committee Meeting: Policy/Instruction/Personnel/Student Services Committee
 Finance/Audit/Facilities/Planning Committee Meeting

Staff Responsible: Aida Salcedo and Vianey Garcia

Presenter's



Purchasing Agent

Signature of Approval

Title

District Improvement Plan Objective, Goal or Need Addressed

RATIONALE:

A request was made to issue a Request for Quote (RFQ) to obtain grease trap services from a qualified firm for services required by the District. The requested services include quarterly pickups from all District sites.

The RFQ notice was mailed out to four (4) vendors. Four (4) vendors responded. An evaluation committee consisting of Ms. Aida Salcedo, Director Food Service, Mr. Sergio Rizo, Food Services HVAC Technician, Mr. Armando Ramos, F & T Specialist, Ms. Sonia Calvillo, Administrative Assistant Career and Technical Education, and Ms. Crystal Rodriguez, Foods Services Clerk Receptionist, met on September 23, 2014, to review and evaluate the responses received.

Ms. Vianey Garcia, Purchasing Agent, and Ms. Corina Heredia, Purchasing Clerk, acted as facilitators and moderators during this evaluation. The committee evaluated and scored all four (4) proposals received. Valley By-Products, Inc. was identified as the company that provides the best value to the District. As a result it is being recommended for award.

RECOMMENDATION/MOTION:

It is recommended that the Board of Trustees approve award of Grease Trap Services RFQ #15-002 to Valley By-Products, Inc. for an estimated amount not to exceed \$11,340.00.

ACCOUNT NO(S). 101.35.6299.00.909

PROCUREMENT METHOD TYPE:

Request for Quote

REQUESTING DEPARTMENT:

Food Service Department

CONSEQUENCES OF NON-APPROVAL:

The District will not be in compliance with the Texas Commission of Environmental Quality.

IMPLEMENTATION TIMELINE:

One (1) year term

ATTACHMENT(S): ✓

Evaluation Tabulation





Request for Board Agenda Item

Purchasing Department

Date: 10/8/14

Campus/Department: Food and Nutrition Service

Vendor Name: Valley By Products Inc.

Total Cost: \$11,340.00

Item Description and Justification for Purchase:

To provide service of the grease traps for each district campus. These services will be done on a quarterly basis.

Participating Schools/Departments: All Campuses

Funding Source: 101.35.6299.00.909.99
(Account number to charge)

Arda Salcedo 10/8/14
Campus/Department Administrator Date Signed

**** (Form must be received by the Purchasing Department by the last Wednesday of the month) ****

(To be completed by the Financial Services Division)

Purchasing Method: Request for Quotes

Nancy Garcia 10/8/14
Purchasing Agent Date Signed

1
Executive Director of Financial Services Date Signed

**CANUTILLO INDEPENDENT SCHOOL DISTRICT
REQUEST FOR QUOTE # 15-002 GREASE TRAP**

School Site	Tank Size GAL	Service Location Address	HENRY'S CESSPOOL SERVICES & CONSTRUCTION INC.	IVAN'S PORTABLE JON'S	SARABIA'S PORTABLE JONS	VALLEY BY-PRODUCTS INC.
DDE	35	8401 Remington Rd. Canutillo, TX 79835	\$121.30	\$75.00	\$80.00	\$90.00
JDE	35	6300 Strahan RD El Paso, TX 79932	\$121.30	\$75.00	\$65.00	\$90.00
CMS	35	7311 Bosque Canutillo TX 79835	\$121.30	\$75.00	\$80.00	\$90.00
BCE	35	770 Cap Carter Rd. Vinton, TX 79821	\$121.30	\$75.00	\$85.00	\$90.00
AMS-1	400	800 Talbot Rd Canutillo TX 79835	\$244.50	\$196.00	\$375.00	\$180.00
AMS-2	35	801 Talbot Rd Canutillo TX 79835	\$121.30	\$75.00	\$80.00	\$90.00
CHS	1800	6675 South Desert Blvd El Paso TX 79932	\$657.50	\$900.00	\$1,750.00	\$810.00
CES-1	800	651 Canutillo Ave Canutillo TX 79835	\$431.50	\$392.00	\$735.00	\$360.00
CES-2	35	652 Canutillo Ave Canutillo TX 79835	\$121.30	\$75.00	\$80.00	\$90.00
GES	900	6550 Westside Dr. El Paso TX 79932	\$449.50	\$441.00	\$810.00	\$405.00
NECHS	35	6701 South Desert Blvd Bldg. N El Paso, TX 79932	\$121.30	\$75.00	\$65.00	\$90.00
Culinary Arts	1000	7965 Art Craft El Paso TX 79932	\$571.00	\$500.00	\$950.00	\$450.00
Quarterly Service Cost			\$3,203.10	\$2,954.00	\$5,155.00	\$2,835.00
Yearly Cost			\$12,812.40	\$11,816.00	\$20,620.00	\$11,340.00
EVALUATION CRITERIA						
The Purchas Price - 40 points			35.40	38.39	22.00	40.00
Quality of the vendor's goods or services - 15 points			15.00	15.00	15.00	15.00
Reputation of the vendor and of the vendor's goods or services - 5 points			5.00	5.00	5.00	5.00
Vendor's past relationship with the District - 10 points			10.00	10.00	10.00	10.00
Any other relevant factor specifically listed in the request for bids or proposals - 5 points			5.00	5.00	5.00	5.00
The extent to which the vendor's goods or services meet the District's needs - 20 points			20.00	20.00	20.00	20.00
Total long-term cost to the district to acquire goods or services - 5 points			5.00	5.00	5.00	5.00
Total Points			95.40	98.39	82.00	100.00
Ranking			3	2	4	1
Four (4) vendors responded. An evaluation committee of six (6) District employees evaluated and scored the proposals received. The evaluation committee is recommending Valley by Products Inc. based on the overall top score and in the best interest to the District.						



Purchasing Approval Sheet

For Presentation to Board of Trustees

Purchasing Department

Financial Services (Verification of Funding Availability and Account Coding)

Approved Denied

Comment: _____

Signature: Martha Aguiar Date: 10/2/14

Federal Programs (For Compliance with Grant Requirements)

Not Required Approved Denied

Comment: _____

Signature: _____ Date: _____

Curriculum & Instruction (For all Curriculum Related Purchases)

Not Required Approved Denied

Comment: _____

Signature: _____ Date: _____

Technology (For all Computer/Software/Peripheral Purchases)

Not Required Approved Denied

Comment: _____

Signature: _____ Date: _____

Legal Review

Not Required Approved Denied

Comment: _____

Signature: _____ Date: _____

Purchasing

Approved Denied

Comment: _____

Signature: Paula G... Date: 10/2/14

Board of Trustees

Meeting Date: 10/15/2014
Agenda Item No.: _____

Executive Summary of Board Agenda Item

Subject/Title for Agenda Posting: Approval to purchase a well pump for Bill Childress Elementary School from Total Mechanical Contractors

Justification Statement: To replace a broken well pump at Bill Childress Elementary School (BCE), which is required to water school grounds and athletic fields.

Purpose of Agenda Item: Action Information Discussion and Recommendation
Committee Meeting: Policy/Instruction/Personnel/Student Services Committee
 Finance/Audit/Facilities/Planning Committee Meeting

Staff Responsible: Dominic Padilla and Vianey Garcia

Presenter(s)

Vianey Garcia

Signature of Approver

Purchasing Agent

Title

District Improvement Plan Objective, Goal or Need Addressed

RATIONALE:

A Request for Quote (RFQ) was processed to obtain prices for the purchase of a pump for the well located at the Bill Childress Elementary School. The Facilities Department would like to purchase a new pump to replace the inoperative pump within the well because the repair of the broken pump is not cost effective. The well serves the irrigation system throughout the campus. Currently, the grounds team is having to manually water the area utilizing facility domestic water, which poses a costly method of watering the area.

Three (3) vendors responded (see attached quotes). Total Mechanical Contractors is being recommended for award because it provide the best value to the District.

As stated in Board Policy CH (Local), any purchase that costs or aggregates to a cost of \$10,000 or more shall require board approval before a transaction may take place.

RECOMMENDATION/MOTION:

It is recommended that the Board of Trustees approve the purchase of the a well pump for Bill Childress Elementary School from Total Mechanical Contractors for a an estimated amount not to exceed \$12,000.00.

ACCOUNT NO(S). 199.81.6629.00.104.99

PROCUREMENT METHOD TYPE:

Request for Quote

REQUESTING DEPARTMENT:

Facilities and Transportation Division

CONSEQUENCES OF NON-APPROVAL:

The grounds team will continue to utilize valuable resources (manpower and domestic water) to landscaped the areas.

IMPLEMENTATION TIMELINE:

Upon approval - one time purchase

ATTACHMENT(S): ✓

Total Mechanical Contractors, Dale Borons Service Supply Inc., and El Paso Phoenix Pumps Inc. Quotes





Request for Board Agenda Item

Purchasing Department

Date: 10/07/2014

Campus/Department: BCE Grounds

Vendor Name: TOTAL MECHANICAL CONTRACTORS

Total Cost: \$ 12,000.00

Item Description and Justification for Purchase:

Grundfos, SWP - 1, 15 HP, 460 V, 3 Phase, 3" NPT Discharge Well pump installation

Included: All required attachments

Mechanical and Electrical work

Pump used to water school grounds and athletic fields

Participating Schools/Departments: Custodial Team / FACILITIES DEPARTMENT

Funding Source: 199-51-6319-00-915-3-99 Maintenance Supplies ^{S/B} 199-81-6629-00-104-99
(Account number to charge)

Campus/Department Administrator

10/7/14

Date Signed

**** (Form must be received by the Purchasing Department by the last Wednesday of the month) ****

(To be completed by the Financial Services Division)

Purchasing Method: Request for Quote

Purchasing Agent

10/7/14

Date Signed

Executive Director of Financial Services

10/7/14

Date Signed

**CANUTILLO INDEPENDENT SCHOOL DISTRICT
WELL PUMP AND INSTALLATION FOR BILL CHILDRESS ELEMENTARY SCHOOL**

	DALE BORENS SERVICE SUPPLY INC.	EL PASO PHOENIX PUMPS, INC.	TOTAL MECHANICAL CONTRACTORS
COST OF PUMP AND INSTALLATION	\$9,479.75	\$13,674.00	\$12,000.00
EVALUATION CRITERIA			
The Purchas Price - 5 points	5.00	3.47	3.95
Vendor's past relationship with the District - 5 points	3	5	5
Reputation of the vendor and of the vendor's goods or services - 5 points	5	5	5
Any other relevant factors (Vendor Package) - 5 points	5	5	5
TOTAL	18.00	18.47	18.95

Three (3) vendors responded. Dale Boren's Service Supply Inc. was awarded partial points under the "vendor's past relationship with the District" criteria because in the recent past the Facilities Department had an issue with the vendor in regards to warranty and service.



(915) 779-8686
 Fax (915) 779-8699
 809 Tony Lama
 El Paso, TX 79915

PAGE	
/	OF /
QUOTATION	
NUMBER	
10103	

TO CISD
 ATTN: MR RAMAS

DATE 10/1/14 DUE DATE

JOB

NO RESPONSIBILITY FOR DELAYS BY REASON OF STRIKES, ACCIDENTS OR CAUSES BEYOND OUR CONTROL.
 PRICES SUBJECT TO CHANGE WITHOUT NOTICE
 ORDERS FOR SPECIAL MATERIAL NOT SUBJECT TO CANCELLATION

LOCATION Sub pump @ CHILDRESS SCHOOL

ARCHITECT

We do not assume responsibility for quantities or description of fixtures. To avoid errors, compare with Plans and Specifications.

ENGINEER

QTY	DESCRIPTION	UNIT	NET PRICE
1	15 HP 6" - 3 PHASE submersible motor with pig tail 48"	\$	2500 ⁰⁰
1	3" discharge - 6" Submersible pump Grundfos # 150S150-7 159 gpm @ 246'		3,470 ⁰⁰
1	3" check valve spring loaded bronze		395 ⁰⁰
1	Splicing kit for cable		15 ⁰⁰
175'	#6 - 4 Submersible cable @ 353/ft		617 ²⁵
4	Lengths of 3" galv. pipe w/coupling	178 ⁰⁰	712 ⁰⁰
1	Shipping charges		350 ⁰⁰
1	LABOR to INSTALL pump, motor and cable - connect to existing control and RUN UNIT and cycle system	\$	1,400 ⁰⁰
1	PVC SLEEVE ON pump -		60 ⁰⁰
			<hr/>
			\$ 9479 ²⁵



Proposal

NUMBER _____

SUBMITTED TO CISD	ATTENTION Armando Ramos	PHONE 915-412-0060	DATE 8/12/2014
STREET 7710 Cap Carter Rd	PROJECT Replace Well Pump		
CITY STATE AND ZIP CODE Canutillo, TX 79835	JOB LOCATION 7710 Cap Carter Rd Canutillo, TX 79935		

We hereby submit specifications and estimates for:

Price to Furnishing and Install Well Pump. \$12,000.00

Model: Grundfos, SWP-1 15 Hp, 460 volts, 3 Phase, 3" NPT Discharge.

Included: Pump and Material	\$8,500.00
Electrical Work	\$1,000.00
Crane	\$1,000.00
Labor	\$1,500.00

Not included: bond, tax, meter fees, permits.

We propose hereby to furnish material and labor-complete in accordance with above specifications, for the sum of:

Dollars **\$12,000.00**

All material is guaranteed to be as specified. All work to be completed in a workmanlike manner according to standard practices. Any alteration or deviation from above specifications involving extra costs will be executed only upon written orders, and will become an extra charge over and above the estimate. All agreements contingent upon strikes, accidents or delays beyond our control. Owner to carry fire, tornado and other necessary insurance.

AUTHORIZED SIGNATURE _____

NOTE THIS PROPOSAL MAY BE

Our workers are fully covered by Workmen's Compensation Insurance.

WITHDRAWN BY US IF NOT ACCEPTED WITHIN 30 DAYS

Acceptance of Proposal--The above prices, specifications and conditions are satisfactory and are hereby accepted. You are authorized to do the work as specified. Payment will be made as outlined above.

Signature: _____
Signature: _____

Date of Acceptance: _____

1900 VICTORY LANE * SUNLAND PARK, NM 88063 * OFFICE (575) 589-1400 * FAX (575) 589-0601

totalmech@totalmechanical.net



EL PASO PHOENIX PUMPS, INC.

26 Butterfield Trail Blvd • El Paso, TX 79906
 Phone: 915-757-1300 • Fax: 915-757-1322

QUOTATION

No. **0038438**

QUOTE DATE	8/28/2014
SALES REPRESENTATIVE	Sergio Vázquez
DIRECT PHONE/FAX	915-757-1300/915-757-1322
E-MAIL ADDRESS	SergioV@ElPasoPhoenixPumps.com
ACCOUNT MANAGER	JOE CRUZ
CONTACT	ARMANDO RAMOS
CUSTOMER REFERENCE	QUOTE ONLY
PHONE NO.	915-877-7421
FAX NO.	915-877-7415
E-MAIL ADDRESS	-

ACCT. NO.	CUSTOMER
2205300	CANUTILLO ISD
TAX STATUS	PROJECT NAME / REFERENCE

BILL TO ADDRESS:	SHIP TO ADDRESS:	PAYMENT TERMS:
CANUTILLO ISD PO BOX 440 CANUTILLO, TX 79835	CANUTILLO ISD 7965 ARTCRAFT RD EL PASO, TX 79932	NET 20
		SHIP METHOD:
		DELIVERY

EL PASO-PHOENIX PUMPS IS PLEASED TO PROVIDE THE FOLLOWING ITEMS FOR YOUR CONSIDERATION:

ITEM#	DESCRIPTION	QTY	PRICE EA.	EXT.	LEAD TIME**
*13B63607	GRUNDFOS 150S150-7 SUBMERSIBLE CENTRIFUGAL PUMP IN STAINLESS STEEL CONSTRUCTION WITH A 3" DISCHARGE AND A 6" MOTOR DIAMETER 15 HP, 3500 RPM, 3 PH, 460 V, 60 HZ MOTOR.	1	\$5,279.00	\$5,279.00	2 TO 3 WEEKS ARO
*OHL	OUT OF HOUSE LABOR INSTALL OHL OUT OF HOUSE LABOR TO INSTALL PUMP AND 3" S40 WLD GALVANIZED PIPE/T & C DOMESTIC, CRANE SERVICE, FITTINGS, AND VALVES, SWING CHECK/BV/LICENSED ELECTRICAL. DOUBLE CLICK ON ICON TO ACCESS SPEC SHEETS	1	\$8,045.00	\$8,045.00	1 WEEK ARO
QUOTE BASED ON MODEL NUMBER AND TECHNICAL SPECIFICATIONS PROVIDED ONLY					

* Denotes a non-stock, special order item

** Product lead times are estimates only

This quotation is valid for 30 days. Stock items are subject to prior sale. We cannot be responsible for delays due to conditions beyond our control. Items contained in this quotation are the only items being supplied by El Paso-Phoenix Pumps, Inc. Any other items which may be required by the specification, including but not limited to the items listed above must be furnished by others. Installation not included and to be done by others. Repair quotes unapproved over 30 days become the property of El Paso-Phoenix Pumps Inc \$ 75.00 Minimum teardown/evaluation fee on unrepared units may apply. El Paso-Phoenix Pumps Terms and Conditions shall apply: <http://phoenixpumps.com/terms.pdf>

\$13,324.00 NET ORDER
 \$350.00 EST. FREIGHT
 \$0.00 SALES TAX
 \$13,674.00 ORDER TOTAL



Purchasing Approval Sheet

For Presentation to Board of Trustees

Purchasing Department

Financial Services (Verification of Funding Availability and Account Coding)

Approved Denied
Comment: Requires Budget Transfer
Signature: [Signature] Date: 10/7/14

Federal Programs (For Compliance with Grant Requirements)

Not Required Approved Denied
Comment: _____
Signature: _____ Date: _____

Curriculum & Instruction (For all Curriculum Related Purchases)

Not Required Approved Denied
Comment: _____
Signature: _____ Date: _____

Technology (For all Computer/Software/Peripheral Purchases)

Not Required Approved Denied
Comment: _____
Signature: _____ Date: _____

Legal Review

Not Required Approved Denied
Comment: _____
Signature: _____ Date: _____

Purchasing

Approved Denied
Comment: _____
Signature: [Signature] Date: 10/7/14



Purchasing Approval Sheet
For Presentation to Board of Trustees
Purchasing Department



Name of Service (Location, Funding Availability and Account Code)
 New Renew

Item: Review Budget Transfer
Signature: [Signature]
Date: 11/17/11

Requesting Department (For Completion with Grant Requests only)
 Not Requested Approved Denied

Date: _____

Requesting Department (For all Comptroller Requested Purchases)
 Not Requested Approved Denied

Date: _____

Requesting Department (For all Comptroller Requested Purchases)
 Not Requested Approved Denied

Date: _____

Requesting Department (For all Comptroller Requested Purchases)
 Not Requested Approved Denied

Date: _____

Requesting Department (For all Comptroller Requested Purchases)
 Not Requested Approved Denied

Date: _____