



**Future Ready. Community Strong.**

## **Regular Meeting Agenda**

Diamondhead Education Center  
200 W. Burnsville Parkway  
Burnsville, MN, 55337  
January 25, 2018  
6:30 PM

(5:45 PM Listening Session with Directors Abigail Alt and Dan Luth)

I. Call to Order	
A. Welcome Public	
B. Pledge of Allegiance	
II. Approval of Agenda	
III. Information	
A. Future Ready. Community Strong.	
1. TIES Exceptional Teachers	3
B. Board of Education Committee Reports	18
IV. Business Meeting	
A. Consent Agenda	
Although Board action is required, it is generally unnecessary to hold discussion on these items. In the event a Board member wishes to discuss an item, that item will be moved for separate consideration.	
1. Approve Meeting Minutes	19
2. Approve Personnel Recommendations	25
3. Adopt a Resolution to Accept Donations	26
4. Approve November Payroll, Receipts, Expenses and Investments	28
5. Budget Analysis	67
6. Report on Listening Session	74
7. Approve, on a Second Reading Basis, Policies 402: <i>Disability Nondiscrimination Policy</i> ; 403: <i>Discipline, Suspension, and Dismissal of School District Employees</i> ; 404: <i>Employment Background Checks</i> ; 424: <i>License Status</i> ; 521: <i>Student Disability Nondiscrimination</i> ; 620: <i>Credit for Learning</i> ; and 903: <i>Visitors to School District Buildings and Sites</i>	75
V. New Business	
A. Approve Initial Extended Field Trip Request for Burnsville High School Students to Travel to Ecuador During Spring Break 2019	98

Presenter: Dave Watkins, Assistant Superintendent, and Bri Ostoff, Youth Service Coordinator

B. Approve Revised Budget for FY18

99

Presenter: Lisa Rider, Executive Director of Business Services

VI. Adjourn to a Closed Session, as Permitted by M.S. 13D.03, for Negotiation Strategies Followed by a Board Workshop for Board Planning



**ONE91**  
Burnsville · Eagan · Savage



# Using Technology to Engage Students

ω



***Future Ready. Community Strong.***

# 2nd Grade: Digital Research

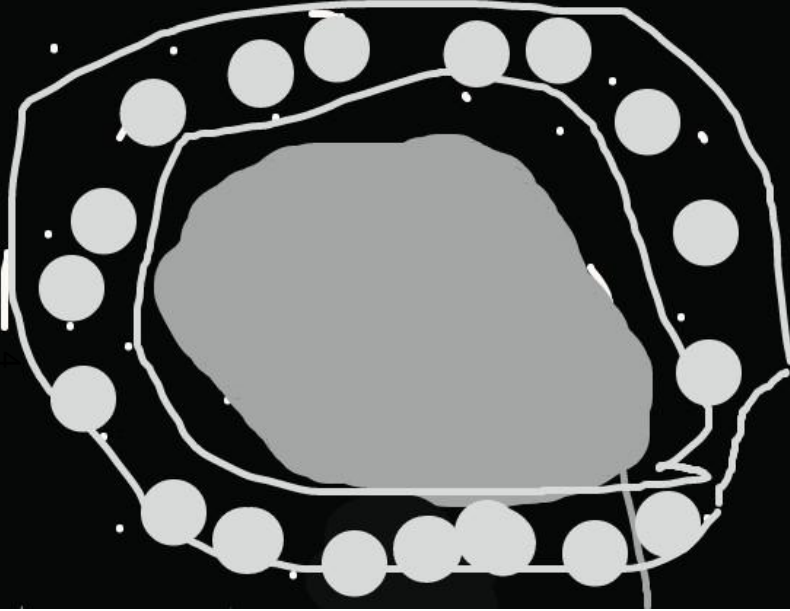

## Student Learning Targets (Taken from Making Meaning Reading Curriculum):

- I can explain what research means.
- I can choose keywords to search for information on the internet.
- I can search for information using reliable sources.
- I can decide what information to explore.
- I can use the information I found.

Planets: Saturn

# 4th Grade: Digital Research

5

Uranus

1. Uranus is the seventh planet from our sun.
2. Uranus is 1,783,939,400 miles/2,870,972,200 kilometers from the sun.
3. Uranus is 60 times as big as earth.
4. It takes uranus 84.02 earth years/30,8 earth days to go around the sun.
5. Uranus was the first planet to discovered.

[http://www.galaxy.com/encyclopedia/planet/uranus.do?cid=1001&view=full&type=REGALTY\\_LIST&searchResultsType=MultiTab&searchType=TopicSearch&fromAccountPubId=1&accountId=1&isFFI=FFI\\_#FFI302908610&type=Topic&context=keyword%3DURANUS&sort=keyword&order=DESC&accountId=1&isFFI=FFI\\_#FFI302908610](http://www.galaxy.com/encyclopedia/planet/uranus.do?cid=1001&view=full&type=REGALTY_LIST&searchResultsType=MultiTab&searchType=TopicSearch&fromAccountPubId=1&accountId=1&isFFI=FFI_#FFI302908610&type=Topic&context=keyword%3DURANUS&sort=keyword&order=DESC&accountId=1&isFFI=FFI_#FFI302908610)



 1 page

how to use reliable websites to find information (britannica, kid info bits)

Nov 10, 2017

Mary Casserly-Smith

Liked Comment

## Student Learning Targets (Taken from Making Meaning Reading Curriculum):

I can choose a source, evaluate it and determine its credibility.

I can use the correct search term to find the answer to a question in a variety of online resources.

I can understand the results of a search.

I can cite my sources.

## Planets: Uranus

# 1st Grade



## Student Learning Targets:

I can research different kinds of boats.

I can design a 2D model.

I can reflect on my learning.

# 4th Grade

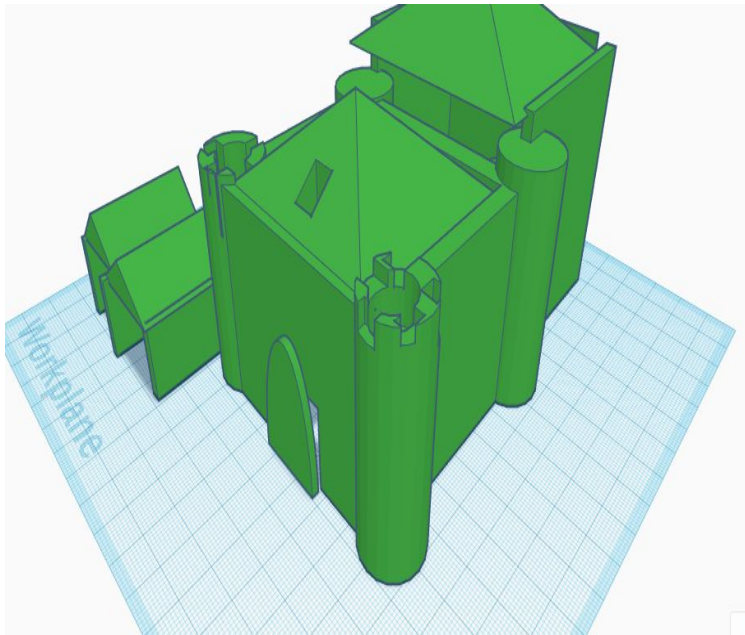

## Student Learning Targets:

I can research different types of castles.

I can tell the difference between 2D and 3D objects.

I can design a 3D model.

I can reflect on my learning.

# 3rd Grade

In response to: Code using Loops in Artist

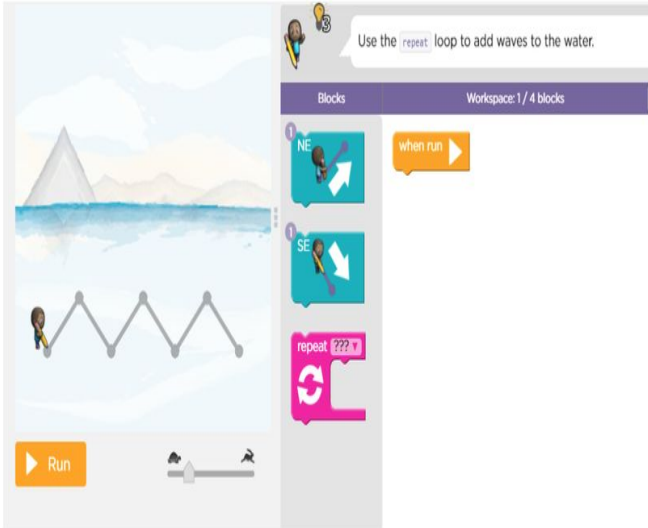

Use the `repeat` loop to add waves to the water.

Blocks Workspace: 1 / 4 blocks

when run

NE

SE

repeat

Run

in order to solve this problem you have to repeat ne se 3 times

Seen by: Scot Danielson

Dec 1, 2017

Like Comment

## The Hour of Code

### Student Learning Targets:

I can create loops within loops to make my program shorter and easier.

I can use symbols to write a program that would draw each image.

# 5th Grade

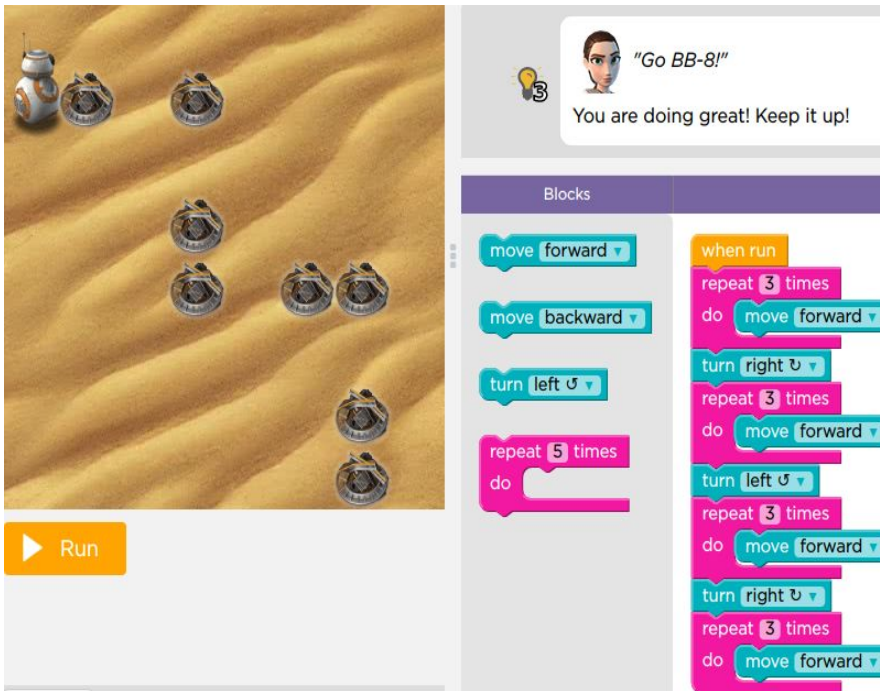

## The Hour of Code

### Student Learning Targets:

I can create a detailed algorithm that can be easily followed

I can use loops and nested loops to run a program

# #GoodNewsCallOfTheDay

Twitter: @casserlymary

10

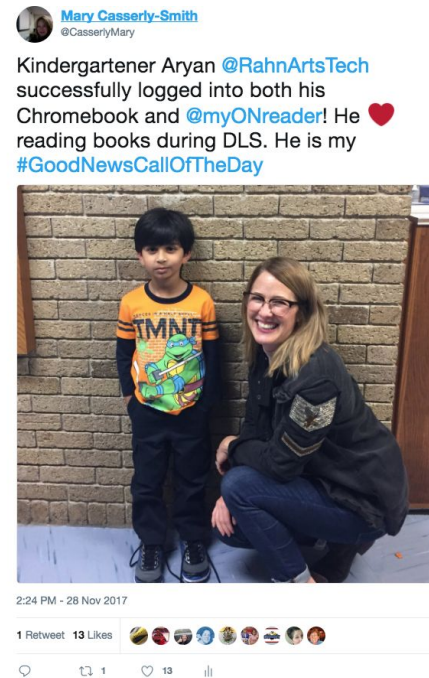

Thank you!



**ONE91**  
Burnsville · Eagan · Savage



*Our Technology  
Journey - One  
Teacher's Perspective*  
**Paul Connell**

12

**Future Ready. Community Strong.**

# 2007-16

- \*Many students didn't have access to devices at home
- \*Difficult to get access to devices at school - competition for labs/carts
- \*Quality of devices at school at varying levels
- \*Outdated homework system: All students complete the assignment and hand it in together, wait for the teacher to grade - put in gradebook - hand back, students see feedback

# Present (2016-18) - Part 1

## Breaking Down Barriers

- \*All students have devices
- \*My students can see assignments and work on them 24/7
- \*No excuses for lost assignments, due dates, not knowing about it - helps with students who get way behind, too
- \*I can see what the students are doing (completion and quality) - conversation is now ("How can I help" vs. "How is it going")
- \*Easy to contact instructors

# Present (2016-18) - Part 2

## Pacing

\*Students can submit assignments as soon as they are finished

\*I grade in Schoology as soon as I can, give feedback, and students can instantly see feedback

\*Much more likely to have different students working on different things - per their needs/abilities

# Looking to the Future

## Teacher Support

\*Tech/Schoolology Support for Teachers by Teachers - Teachers need time and help figuring out how to use resources and options to digitize

## Student Flexibility in Course Options

\*Hybrid Courses (Part online and part in-class)

\*Online Courses

-Give students a chance to explore their pathways

## Students Using Resources

\*We need to teach the students the technology as a tool and not just for videos and games (ie - advanced Google Searching, Digital Presentations, Chrome Extensions, Chromebook functionality, etc)

Thank you



**Agenda III.B.  
January 25, 2018**

**To:** Board of Education, Members  
Cindy Amoroso, Superintendent

**From:** Jim Schmid, Chair

**Date:** January 20, 2018

**Re:** Committee Reports

The following committees may provide updates to the School Board:

Technology Committee – Bob VandenBoom, Committee Chair  
Policy Review Committee – Abigail Alt, Committee Chair  
Student Performance and Achievement – Dan Luth, Committee Chair  
Negotiating Committee- Dan Luth, Committee Chair  
Intermediate School District 917, DeeDee Carrier, Board Representative  
TIES, Abigail Alt, Board Representative

Other Board Assignments:

- MSBA
- AMSD
- Foundation 191
- Minnesota State High School League
- BHS Hall of Fame
- Burnsville Chamber of Commerce
- Savage Chamber of Commerce
- Dakota Chamber of Commerce
- Scott County SCALE
- U of M CIS

School Board Minutes  
INDEPENDENT SCHOOL DISTRICT 191  
January 11, 2018

The meeting of the Board of Education was called to order by Chair Alt at 6:30 p.m. at the Diamondhead Education Center, 200 West Burnsville Parkway, Burnsville, MN. Call to Order

Members present: Directors Currier, VandenBoom, Schmid, Miller, Schatz, and Chair Alt. Luth was absent. Others in attendance were Superintendent Amoroso, Student Representative Haddorff, administrators, staff and members of the public. Attendance

Alt welcomed the audience and asked Haddorff to lead the Pledge of Allegiance. Pledge of Allegiance

Moved by Miller, seconded by Schatz, to approve the agenda. Motion carried unanimously (6, 0). Agenda

Moved by Director Alt that Director Schmid be nominated and elected chair of the board for 2018. Motion carried unanimously (6, 0). Chair

Schmid began to chair the meeting.

Moved by Director VandenBoom that Director Currier be nominated and elected vice chair of the board for 2018. Motion carried unanimously (6, 0). Vice Chair

Moved by Director Schmid that Director VandenBoom be nominated and elected clerk of the board for 2018. Motion carried unanimously (6, 0). Clerk

Moved by Director Currier that Director Luth be nominated and elected treasurer of the board for 2018. Motion carried unanimously (6, 0). Treasurer

Moved by VandenBoom, seconded by Alt, that salaries of board members be set at \$550 per month and that the chairperson receives an additional \$50 per month in recognition of additional duties and expenses associated with the position. Motion carried unanimously (6, 0). Salaries

Moved by Schatz, seconded by Currier, that all regular meetings of the Independent School District 191 Board of Education commence at 6:30 p.m. on the dates noted below with meetings conducted at the Diamondhead Education Center and cable cast. Superintendent Listening Sessions or Board Listening Sessions will be scheduled at 5:45 p.m. before regular board meetings. Regular Meetings

Jan. 25, 2018	Oct. 25, 2018
Feb. 8, 2018	Nov. 15, 2018*
Feb. 22, 2018	Dec. 13, 2018
March 8, 2018	Jan. 10, 2019
March 15, 2018**	Jan. 24, 2019
April 12, 2018	Feb. 21, 2019*
April 26, 2018	Feb. 28, 2019
May 10, 2018	March 14, 2019
May 24, 2018	March 21, 2019*
June 14, 2018	April 11, 2019
June 21, 2018**	April 25, 2019
Aug. 9, 2018	May 9, 2019
Aug. 23, 2018	May 23, 2019
Sept. 13, 2018	June 13, 2019
Sept. 27, 2018	June 20, 2019*
Oct. 11, 2018	Aug. 8, 2019
	Aug. 22, 2019

In the case of inclement weather, the Board meeting will be scheduled Monday at the same time and place unless Monday is a holiday, in which case a special meeting will be posted. Motion carried unanimously (6, 0).

Moved by Miller, seconded by VandenBoom, to approve items G-N with removal of item L as a consent agenda:

- Adopt the attached resolution which authorizes the executive director of business services to enter into electronic (telephone) fund transfer agreements with the district's official depositories per Chapter 334 of the laws of Minnesota.
- Adopt the attached resolution authorizing the use of facsimile signatures on payroll and claim checks as prescribed in M.S. 47.41 and furthermore that the use of facsimile signatures be authorized for individual personnel contracts covered by board adopted master agreements.
- Designate as official depositories of the district for the 2018 calendar year per M.S. 124.05.U.S. Bank of Minneapolis, Minnesota School Districts Liquid Asset Fund Plus, MN Trust, and Associated Bank, WI.
- Designate committee assignments at a future board meeting.
- Designate as of January 1, 2018, Cindy Amoroso, superintendent or her designee as the agent in filing applications for and representing the district in state- and federally-funded programs.
- Designate Sun Thisweek as the official newspaper for 2018 per M.S. 123.33; Subdivision 11, and M.S. Chapter 331.
- Authorize Cindy Amoroso, superintendent, and Jami Kenney, executive administrative assistant to act as the Identified Officials with Authority (IOWA) for Burnsville-Eagan-Savage School District 191. Jami Kenney's role as IOWA will be to add pre-authorizations and review authorizations. authorizations. Motion carried unanimously (6, 0).

Consent G-N

Electronic Fund Transfer

Facsimile Signatures

Depositories

Committee Federally-funded Applications

Official Newspaper

IOWA

Moved by Alt, seconded by Currier, to appoint the following firms as legal counsel for Independent School District 191 for 2018 and that they be paid on an hourly basis for services rendered: Kenney & Graven Chartered; Goetz & Eckland P.A.; Booth Law Group LLC; Rupp, Anderson, Squires & Waldspurgen, P.A.; Knutson, Flynn & Deans, P.A.; Hitesman & Wold, P.A. Motion carried unanimously after discussion (6, 0).

Legal Counsel

Received a report regarding Metcalf Middle School Peer Leaders.

Information

Received verbal reports from Student Representative Haddorff, Superintendent Amoroso, and Board Members Schatz, Alt, and VandenBoom.

Moved by Currier, seconded by Miller, to approve the consent agenda with removal of item number 5 and Policy 302: *Superintendent*.

- Approve minutes of the regular board meeting on December 16, 2017.
  - Approve personnel recommendations for S. Erbes, T. Nelson, K. Oscarson, J. Kennedy, A. Holloway, C. Catherine, J. Rossakis, J. Saba, H. Ohama, J. Lautiger-Beautz, J. Derusha, R. Tousignant, R. Cesaro-Moxley, E. Kaas, B. Davis, V. Cornelius, J. Phommajack, M. Casler, M. McClellan, F. Kayla, P. Lundberg-Schmidt, M. Portwood, B. Skelly, K. Quesenberry, R. Reuder, S. Ripoli, N. Scott, F. Strauss, M. Weingartz, R. David, E. Counters, C. Holt, J. Powers, and M. Amanda.
  - Adopt a resolution to approve and accept donations.
  - Receive a report on the listening session.
  - Approve, on a first reading basis, 402: *Disability Nondiscrimination Policy*; 404: *Employment Background Checks*; 424: *License Status*; and 521: *Student Disability Nondiscrimination*.
- Motion carried unanimously (6, 0).

Minutes  
Personnel  
Recommendations

Moved by VandenBoom, seconded by Schatz, to refer Policy 418: *Drug-Free Workplace/Drug-Free School* back to the Policy Review Committee. Motion carried unanimously after discussion (6, 0).

Donations  
Listening Session  
Policies

Moved by VandenBoom, seconded by Miller, to approve no changes to Policies 401: *Equal Employment Opportunity*; 407: *Employee Right to Know-Exposure to Hazardous Substances*; 422: *Policies Incorporated by Reference*; 497: *Employee Work Day*; 498: *Political Campaigns and Activities*; 499: *Nepotism Prohibition*; 302: *Superintendent* and 714: *Fund Balances*. Moved by VandenBoom, seconded by Currier, to remove Policy 302 from the recommendation and refer it back to the Policy Review Committee. Amended motion carried unanimously (6, 0). Main motion carried unanimously after discussion (6, 0).

Moved by VandenBoom, seconded by Miller, to approve the 2018-19 Secondary Course Catalog. Motion carried unanimously after discussion

2018-19

(6, 0).

Moved by Schatz, seconded by Alt, to approve, on a first reading basis, Policies 620: *Credit for Learning*, and 903: *Visitors to School District Buildings and Sites*. Motion carried unanimously (6, 0).

Moved by Currier, seconded by Schatz, to approve, on a first reading basis, changes to Policy 425: *Professional Development* with modifications to include a report to the Board of Education. Motion carried unanimously after discussion (6, 0).

Moved by Schatz, seconded by Miller, to approve, on a first reading basis, changes to Policies 305: *Policy Implementation*, and 403: *Discipline, Suspension, and Dismissal of School District Employees*. Moved by Schmid, seconded by Alt, to remove 305 from the motion. Amended motion carried (6, 0). Main motion carried unanimously after discussion (6, 0).

A special meeting has been called on Tuesday, January 16, 2018 at 7:15 a.m.

Moved by Alt, seconded by Miller, to adjourn at 8:14 p.m. to a closed session, as permitted by M.S. 13D.03, for negotiation strategies. Motion carried unanimously (6, 0).

Secondary Course  
Catalog

Policy

Announcement

Adjourn to a  
closed session

January 25, 2018

Bob VandenBoom, clerk

Date Approved

Closed Session Minutes  
INDEPENDENT SCHOOL DISTRICT 191  
January 11, 2018

The Board meeting was called to order by Chair Schmid at 8:28 p.m. at Diamondhead Education Center, 200 West Burnsville Parkway, Burnsville, MN.

Call to Order

Members present: Directors Currier, Schatz, Miller, VandenBoom, Alt and Chair Schmid. Luth was absent.

Attendance

Others in Attendance: C. Amoroso, superintendent; L. Rider, executive director of business services; S. Sovine, executive director of human resources; D. Watkins, assistant superintendent; and J. Kenney, executive administrative assistant.

The meeting was closed, as permitted by Minnesota Statutes 13D.03, to discuss ISD 191's labor negotiation strategies with the Burnsville Education Association.

Purpose

The meeting adjourned at 8:55 p.m.

Adjourn

---

Bob VandenBoom, clerk

January 25, 2018  
Date Approved

School Board Minutes  
INDEPENDENT SCHOOL DISTRICT 191  
January 16, 2018

The special meeting of the Board of Education was called to order by Chair Schmid at 7:15 a.m. at the Diamondhead Education Center, 200 West Burnsville Parkway, Burnsville, MN, 55337.

Call to Order

Members present: Directors Currier, VandenBoom, Alt, Schatz, Luth, Miller and Chair Schmid.

Attendance

Superintendent Amoroso, L. Rider, S. Sovine, and J. Kenney were present.

Schatz led the Pledge of Allegiance.

Pledge

Moved by Miller, seconded by Schatz, to approve the agenda. Motion carried unanimously (7, 0).

Moved by Schatz, seconded by VandenBoom, to approve board representative appointments for 2018: Policy Committee: VandenBoom, Schatz, Alt (chair); SPA Committee: Luth (chair), Miller, Alt; Technology Committee: VandenBoom (chair), Miller, Currier; Negotiations Committee: Luth (chair), Currier, Schatz; 917: Currier; TIES: Alt; MSBA: VandenBoom; AMSD: Currier (Schatz as alternate); Foundation 191: Schatz; Minnesota State High School League: Schmid; BHS Hall of Fame: Currier; Burnsville Chamber of Commerce: Alt; Savage Chamber of Commerce: Miller (Currier as alternate); Dakota Chamber of Commerce: VandenBoom; Scott County SCALE: TBD Luth or Currier; and U of M CIS Program: Schatz. Moved by Luth to amend the list so the appointment for TIES would be Luth not Alt. The amended motion was not seconded. Main motion carried unanimously after discussion (7, 0).

Board  
Representatives  
for 2018

Moved by Luth, seconded by Schatz, to adjourn at 7:25 p.m. Motion carried unanimously (7, 0).

Adjourn

---

Bob VandenBoom, clerk  
January 25, 2018  
Date Approved

January 25, 2018

**Burnsville-Eagan-Savage Public Schools  
Independent School District 191  
Human Resources**

TO: Members, Board of Education  
Cynthia Amoroso, Superintendent

FROM: Stacey Sovine, Executive Director of Human Resources

DATE: January 25, 2018 FINAL

RE: Recommended Personnel Changes

CLASSIFICATION	ACTION	POSITION CONTROL	NAME	FINAL	LOCATION	POSITION	EFFECTIVE DATE
Certified	Appointment	New Position	Alexandra Selliris	*	Edward Neill Elementary	Teacher SPED	1/22/2018
Certified	Leave of Absence		Jessica Perry		Harriet Bishop Elementary	Teacher	2017/2020 School Year
Certified	Leave of Absence		Rachel Wenz		Rahn Elementary School	Teacher	2018/2019 School Year
Classified	Appointment		Javarius Thorton-Barber	*	Community Education	CE Program Associate	1/19/2018
Classified	Appointment	Replacement	Britney Lallier		Nicollet Middle School	Clerical Level IV	1/22/2018
Classified	Appointment	Replacement	Annette Martinez	*	District-wide	Custodian	1/22/2018
Classified	Appointment	New Position	Roxanne Leake		District-wide	AVID Tutor	1/17/2018
Classified	Change of Assignment		Erin Husen		Gideon Pond Elementary	Food Service Associate	1/16/2018
Classified	Change of Assignment		Camille DeCarlo	*	Eagle Ridge Middle School	Food Service Associate	2/1/2018
Classified	Resignation		Jessica Phommajack		Eagle Ridge Middle School	Food Service Associate	1/16/2018
Classified	Retirement		Ruth Dunn		Diamondhead Education Center	Director of Communications	1/4/2019
Classified	Retirement		Suzann Van Guilder		MW Savage Elementary School	EA Level IV	2/15/2018
Classified	Termination		Rose Davis- Revised		District-wide	AVID Tutor	12/15/2017
Classified	Termination		Beth Davis	*	MW Savage Elementary School	Food Service Associate	1/19/2018



**Agenda IV.A.3.  
January 25, 2018**

**To:** Members, Board of Education  
Cindy Amoroso, Superintendent

**From:** Lisa K. Rider, Executive Director of Business Services

**Date:** January 18, 2018

**Re:** Donations

**RECOMMENDATION:** To adopt a resolution to approve and accept donations as presented.

**RESOLUTION TO ACCEPT DONATIONS**

**WHEREAS,**

1. School Board Policy 706 establishes guidelines for the acceptance of gifts to the District; and
2. Minnesota Statute 123B.02, Subd. 6 states the School Board may receive, for the benefit of the district, bequests, donations, or gifts for any proper purpose and apply the same to the purpose designated; and
3. Minnesota Statute 465.03 states the School Board may accept a grant or devise of real or personal property only by the adoption of a resolution approved by two-thirds of its members; and
4. Businesses and individuals have submitted donations to the district;

**THEREFORE, BE IT RESOLVED** by the School Board of ISD 191 to approve and accept with appreciation the donations as presented below and to permit their use as designated by the donors.

Moved by: \_\_\_\_\_

Seconded by: \_\_\_\_\_

Members in favor of the motion:

Members opposed:

Whereupon said Resolution was declared duly passed and adopted on January 25, 2018.

---

Bob VandenBoom  
Clerk – Board of Education

<b>Date</b>	<b>Donor</b>	<b>Recipient</b>	<b>Terms</b>	<b>Donation</b>
1/4/2018	Walmart #5977	Burnsville High School	Giving Non-Emergency	\$500.00
1/5/2018	Kim Finley	Rahn Elementary	to help the school	2 tickets to the MN Zoo
1/5/2018	The Benevity Community Impact Fund	Harriet Bishop Elementary	To help support our students and staff	\$100.00
1/8/2018	Buck Hill / Chip Solner	Eagle Ridge Middle School	PBIS FIRE	2 All day ski or showboard lift tickets to Buck Hill
1/8/2018	Skateville	Eagle Ridge Middle School	PBIS FIRE	16 buy one get one admission to Skateville
1/8/2018	Bowlero - Jessica Davenport	Eagle Ridge Middle School	PBIS FIRE	2 free hours of unlimited bowling x 6
1/3/2018	T L Ishe	BrainPower in a Backpack	Cash donation	\$50.00
1/4/2018	Paul Wallenta	BrainPower in a Backpack	Cash donation	\$200.00
12/31/2018	Joel Mullins	BrainPower in a Backpack	Cash donation	\$2,000.00
1/5/2018	Walmart Community Grant -- Burnsville location	BrainPower in a Backpack	Cash donation	\$500.00
11/21/2017	Berean Baptist Church	Vista View Elementary	To help our students and families	Backpacks full of school supplies and Full Thanksgiving Meals for families

**Total monetary donation received: \$3,350.00**



**Future Ready. Community Strong.**

**Agenda IV.B.4  
January 16, 2018**

**TO: Cindy Amoroso, Superintendent and Board of Education**  
**FROM: Lisa K. Rider, Executive Director of Business Services**  
**DATE: January 25, 2018**  
**RE: November Payroll, Claims and Receipts**

**RECOMMENDATION:** That the Board approves Nov payroll checks numbered 718912-718927 and Direct Deposit notices numbered 663490-666555 in the net amount of \$3,905,940.36. Nov & Dec claims to date represented by checks numbered 456005-456603, 1018995-1019155, and 102128-102134 and wire transfers and adjustments totaling \$8,273,985.50. Also, that the Board accepts Nov receipts of \$10,332,669.49 and investments for the General Fund, 2012A Alt Facilities & 2015A School Building Bonds and OPEB of \$49,557,433.47 as of November 30, 2017.

November payroll, wire transfers, claims and receipts have been prepared under the direction of Robin Pikal, Director of Accounting, and are presented for approval by the School Board.

LKR/mw

**INDEPENDENT SCHOOL DISTRICT 191  
FINANCIAL REPORT  
November 2017**

**Cash Receipts**

Receipts		
Miscellaneous Adjustments		\$10,332,669.49

<b>TOTAL NOV CASH RECEIVED</b>	<b>10,332,669.49</b>
--------------------------------	----------------------

**CASH DISBURSEMENTS**

November

Regular Payroll Checks	718912-718927	\$3,905,940.36
Direct Deposit Notices	663490-666555	

Oct payables previously approved:		\$629,793.17
Nov Claims previously approved:		\$954,768.89

Nov Claims:	456005-456213	\$1,123,262.19
	1018995-1019042	

NovA/P Wires- Wires+P1+P-card		\$5,008,046.19
Miscellaneous Adjustments		\$1,868.16

<b>TOTAL NOV CASH DISBURSED</b>	<b>11,623,678.96</b>
---------------------------------	----------------------

**TOTAL EXPENSES TO BE APPROVED**

Nov Cash Disbursed		\$11,623,678.96
Less: Items Previously Approved		-\$1,584,562.06

Plus: Nov Payables	456214-456304	\$541,035.34
Checks	456455-456530	

Dec Claims:	456305-456454	\$1,599,773.62
Checks	456531-456603	
	1019043-1019155	
	102126-102134	

<b>TOTAL TO BE APPROVED</b>	<b>12,179,925.86</b>
-----------------------------	----------------------

	<u>Money Market</u>	<u>(Original Cost)</u> <u>Investments</u>	<u>Total 11/30/2017</u>
GENERAL FUND	\$1,045,638.68	\$31,186,550.00	\$32,232,188.68
OPEB	\$393,796.95	\$8,666,762.00	\$9,060,558.95
OPEB EQUITY INV THROUGH OCTOBER 31, 2017	\$20,786.18	\$4,191,912.19	\$4,212,698.37
2015A SCHOOL BUILDING BONDS	\$651,987.47	\$3,400,000.00	\$4,051,987.47
	\$2,112,209.28	\$47,445,224.19	\$49,557,433.47

Note: The attached investment reports are provided by our investment advisor, PMA Financial Network, Inc. These reports include our investment and money market balances.



# Total Portfolio Report CAR

As of: 11/30/17

PMA Financial Network, Inc.

2135 CityGate Lane  
7th Floor  
Naperville, Illinois 60563  
Telephone . 630-657-6400  
Facsimile . 630-718-8701

## BURNSVILLE ISD 191 / GENERAL FUND

2960

Type	Trans	SEQ	Purchase	Maturity	Instrument	Par-Val/Mat. Val.	Original Cost	Rate
LTD	0	1	11/30/17	11/30/17	PMA SECURITIES SYNDICATE (PMAS)	\$6,723,450.00	\$6,723,450.00	
MM					Investment Shares Portfolio	\$1,045,638.68	\$1,045,638.68	
TS	248081	1	11/02/17	12/01/17	MN TRUST TERM SERIES	\$15,313,371.78	\$15,300,000.00	1.100
CD	223724	1	05/02/16	01/26/18	PREMIER BANK	\$249,908.02	\$246,900.00	0.701
CD	223725	1	05/02/16	01/26/18	REPUBLIC BANK OF CHICAGO	\$249,902.04	\$246,900.00	0.700
CD	230000	1	08/17/16	01/26/18	CFG COMMUNITY BANK	\$249,974.65	\$247,500.00	0.693
CD	230001	1	08/17/16	01/26/18	BANK OF THE OZARKS	\$249,895.85	\$247,600.00	0.649
CD	229998	1	08/17/16	02/09/18	EAST BOSTON SAVINGS BANK	\$249,945.22	\$247,200.00	0.749
CD	229999	1	08/17/16	02/09/18	CAPITAL BANK NA	\$249,966.87	\$247,400.00	0.700
CD	229997	1	08/17/16	02/20/18	TBK BANK, SSB / THE NATIONAL BANK	\$247,169.61	\$244,400.00	0.749
SEC	38090	1	08/31/16	02/28/18	Independence Bank Of Kentucky Certificate of Deposit	\$249,000.00	\$249,000.00	0.701
CD	232867	1	10/18/16	04/18/18	US METRO BANK	\$249,977.02	\$247,200.00	0.750
CD	232868	1	10/18/16	04/18/18	EAGLEBANK / VIRGINIA HERITAGE BANK	\$249,977.43	\$247,200.00	0.750
SEC	38699	1	10/26/16	04/26/18	Capital One, National Association Certificate of Deposit	\$248,000.00	\$248,000.00	0.985
SEC	38701	1	10/28/16	04/27/18	Synovus Bank Certificate of Deposit	\$248,000.00	\$248,000.00	0.818
SEC	40158	1	08/09/17	05/15/18	Bank Of China Certificate of Deposit	\$247,000.00	\$247,000.00	1.266
CD	229994	1	08/17/16	08/17/18	PACIFIC WESTERN BANK	\$249,849.36	\$244,900.00	1.011
CD	229995	1	08/17/16	08/17/18	FARMERS & MERCHANTS UNION BANK	\$249,879.07	\$245,500.00	0.892
CD	229996	1	08/17/16	08/17/18	INDEPENDENCE BANK- MT	\$249,957.57	\$246,300.00	0.743
CD	230012	1	08/18/16	08/21/18	SOLARITY CREDIT UNION	\$1,521,540.91	\$1,500,000.00	0.720
SEC	38088	1	08/24/16	08/24/18	Yadkin Bank Certificate of Deposit	\$249,000.00	\$249,000.00	0.738
SEC	38086	1	08/25/16	08/27/18	Bankunited, NA Certificate of Deposit	\$248,000.00	\$248,000.00	0.851
CD	244784	1	08/31/17	08/31/18	CORPORATE ONE FEDERAL CREDIT UNION	\$249,907.10	\$246,700.00	1.300
SEC	38087	1	08/31/16	08/31/18	Wells Fargo Bank, NA - Sd Certificate of Deposit	\$249,000.00	\$249,000.00	0.951
SEC	38089	1	08/31/16	08/31/18	Guaranty Bank And Trust Company Certificate of Deposit	\$249,000.00	\$249,000.00	0.751
CD	246451	1	09/26/17	09/26/18	FIRST COMMONS BANK NA	\$249,983.84	\$246,500.00	1.413
CD	246452	1	09/26/17	09/26/18	QUONTIC BANK, FSB	\$249,910.61	\$246,600.00	1.343
CD	232865	1	10/18/16	10/25/18	ACB BANK	\$249,961.39	\$245,500.00	0.900
CD	232866	1	10/18/16	10/25/18	FREEMPORT STATE BANK	\$249,979.96	\$245,800.00	0.842
SEC	39527	1	05/10/17	11/13/18	American Express Centurion Bank Certificate of Deposit	\$248,000.00	\$248,000.00	1.435
SEC	40472	1	09/06/17	12/06/18	American Express Bank, Fsb Certificate of Deposit	\$247,000.00	\$247,000.00	1.533
SEC	39192	1	01/31/17	01/31/19	BMW Bank Of North America Certificate of Deposit	\$248,000.00	\$248,000.00	1.417
SEC	40160	1	08/03/17	02/04/19	Morgan Stanley Bank, National Association Certificate of Deposit	\$247,000.00	\$247,000.00	1.468
SEC	40161	1	08/03/17	02/04/19	Morgan Stanley Private Bank, National Association Certificate of Deposit	\$247,000.00	\$247,000.00	1.468
SEC	40516	1	09/07/17	03/07/19	Comenity Capital Bank / World Financial Capital Bank Certificate of Deposit	\$249,000.00	\$249,000.00	1.469

Type	Trans SEQ	Purchase	Maturity	Instrument	Par-Val/Mat. Val.	Original Cost	Rate
<i>Note: Weighted Yield &amp; Weighted Average Portfolio Maturity are calculated only on the CD, CP, &amp; SEC desk.</i>					<b>Total Amount --&gt;</b>	<b>\$32,323,146.98</b>	<b>\$32,232,188.68</b>

**Time and Dollar Weighted Portfolio Yield:** 1.049 %

**Weighted Average Portfolio Maturity:** 67.59 Days

**MM:** 3.24%  
**CD's:** 17.65%  
**CP:** 0.00%  
**SEC:** 10.77%

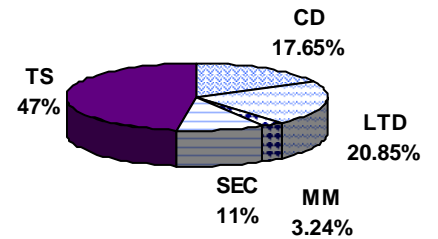
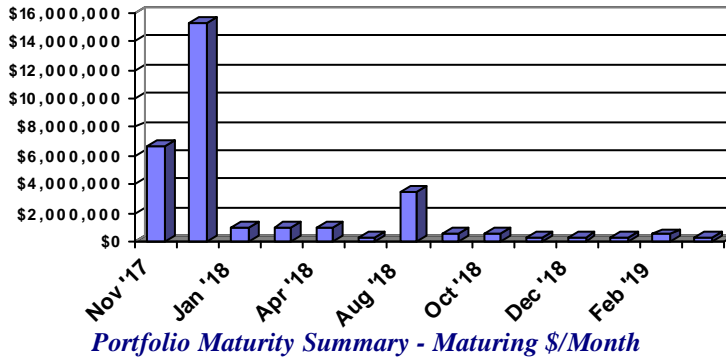



# Total Portfolio Report CAR

As of: 11/30/17

PMA Financial Network, Inc.

2135 CityGate Lane  
7th Floor  
Naperville, Illinois 60563  
Telephone . 630-657-6400  
Facsimile . 630-718-8701

## BURNSVILLE ISD 191 / 2009 OPEB TRUST

3596

Type	Trans	SEQ	Purchase	Maturity	Instrument	Par-Val/Mat. Val.	Original Cost	Rate
MM					Investment Shares Portfolio	\$393,796.95	\$393,796.95	
CD	205079	1	01/08/15	01/08/18	FIRST FREEDOM BANK	\$164,252.21	\$159,400.00	1.012
CD	205080	1	01/08/15	01/08/18	TRUSTONE FINANCIAL FEDERAL CREDIT UNION	\$249,684.73	\$241,600.00	1.111
CD	205081	1	01/08/15	01/08/18	HIBERNIA BANK	\$207,054.62	\$201,000.00	1.003
CD	192888	1	01/13/14	01/16/18	INDUSTRIAL & COMMERCIAL BANK OF CHINA	\$210,686.40	\$200,000.00	1.332
SEC	33742	1	01/14/15	01/16/18	Goldman Sachs Bank USA Certificate of Deposit	\$248,000.00	\$248,000.00	1.404
CD	205817	1	02/03/15	02/05/18	ADIRONDACK BANK	\$240,475.35	\$234,000.00	0.921
CD	205818	1	02/03/15	02/05/18	FIRST NB OF MCGREGOR	\$102,681.43	\$100,000.00	0.891
CD	205819	1	02/03/15	02/05/18	FIRST NATIONAL BANK	\$249,815.96	\$243,000.00	0.932
SEC	33857	1	02/05/15	02/05/18	Ally Bank Certificate of Deposit	\$248,000.00	\$248,000.00	1.154
CD	182782	1	02/15/13	02/15/18	PLAINS COMMERCE BANK	\$249,902.70	\$236,400.00	1.142
CD	208034	1	03/24/15	03/26/18	PEAPACK-GLADSTONE BANK	\$208,860.51	\$203,000.00	0.960
SEC	30731	1	09/25/13	09/25/18	Discover Bank Certificate of Deposit	\$247,000.00	\$247,000.00	2.013
SEC	30738	1	09/25/13	09/25/18	Compass Bank Certificate of Deposit	\$247,000.00	\$247,000.00	1.962
CD	192886	1	01/13/14	01/14/19	M.Y. SAFRA BANK	\$248,142.42	\$228,500.00	1.717
CD	192887	1	01/13/14	01/14/19	STEARNS BANK NA (N)	\$248,500.88	\$230,700.00	1.542
SEC	28287	1	10/09/12	01/15/19	Lakewood Township NJ Ref	\$630,000.00	\$630,000.00	1.580
SEC	28397	1	11/15/12	08/15/19	DENTON TX INDEP SCH DIST TXBL -REF - SER C	\$1,000,000.00	\$1,000,000.00	1.520
CD	232809	1	10/14/16	10/15/19	GBC INTERNATIONAL BANK	\$249,730.21	\$241,800.00	1.092
CD	232810	1	10/14/16	10/15/19	LUANA SAVINGS BANK	\$237,251.62	\$230,000.00	1.050
CD	232811	1	10/14/16	10/15/19	CITIZENS STATE BANK OF LA CROSSE	\$106,113.69	\$103,200.00	0.940
SEC	28316	1	10/15/12	10/15/19	ABERDEEN TWP NJ REF	\$390,000.00	\$390,000.00	1.570
SEC	28317	1	10/16/12	12/01/19	FAIRFIELD & UNION OH LOCAL SCH DIST	\$330,000.00	\$294,162.00	1.620
SEC	28355	1	10/19/12	12/01/19	COOK CNTY IL HIGH SCH DIST #205 THORNTON TWP	\$350,000.00	\$350,000.00	1.939
SEC	38171	1	09/02/16	10/01/20	City of New York NY	\$345,000.00	\$345,000.00	1.300
SEC	40118	1	07/31/17	12/15/20	Kane County Forest Preserve District	\$1,450,000.00	\$1,450,000.00	1.670
SEC	38170	1	09/02/16	03/01/21	City of Rochester NH	\$365,000.00	\$365,000.00	1.340

Type	Trans	SEQ	Purchase	Maturity	Instrument	Par-Val/Mat. Val.	Original Cost	Rate
<i>Note: Weighted Yield &amp; Weighted Average Portfolio Maturity are calculated only on the CD, CP, &amp; SEC desk.</i>						<b>Total Amount --&gt;</b>	<b>\$9,216,949.68</b>	<b>\$9,060,558.95</b>

**Time and Dollar Weighted Portfolio Yield: 1.537 %**

**Weighted Average Portfolio Maturity: 539.93 Days**

**MM: 4.35%**  
**CD's: 31.48%**  
**CP: 0.00%**  
**SEC: 64.17%**

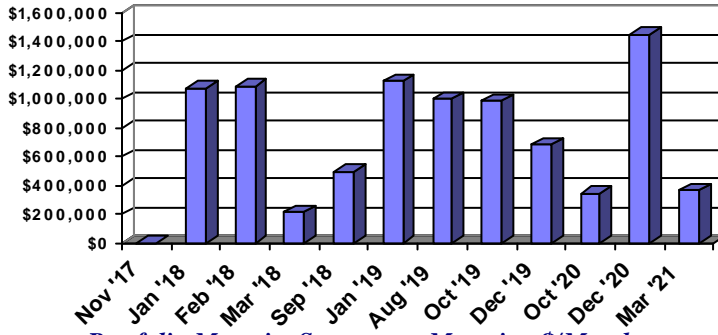

**Portfolio Maturity Summary - Maturing \$/Month**

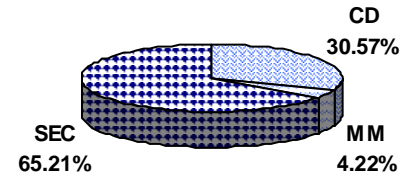

**Portfolio Allocation by Transaction Type**



# Total Portfolio Report CAR

As of: 11/30/17

PMA Financial Network, Inc.

2135 CityGate Lane

7th Floor

Naperville, Illinois 60563

Telephone . 630-657-6400

Facsimile . 630-718-8701

## BURNSVILLE ISD 191 / 2015A BONDS

5762

Type	Trans	SEQ	Purchase	Maturity	Instrument	Par-Val/Mat. Val.	Original Cost	Rate
MM					Investment Shares Portfolio	\$651,987.47	\$651,987.47	
TS	248082	1	11/02/17	12/01/17	MN TRUST TERM SERIES	\$3,002,621.92	\$3,000,000.00	1.100
TS	248489	1	11/14/17	12/14/17	MN TRUST TERM SERIES	\$400,361.65	\$400,000.00	1.100
<b>Total Amount --&gt;</b>						<b>\$4,054,971.04</b>	<b>\$4,051,987.47</b>	

Note: Weighted Yield & Weighted Average Portfolio Maturity are calculated only on the CD, CP, & SEC desk.

Time and Dollar Weighted Portfolio Yield: 1.100 %

Weighted Average Portfolio Maturity: 2.12 Days

MM: 16.09%

CD's: 0.00%

CP: 0.00%

SEC: 0.00%

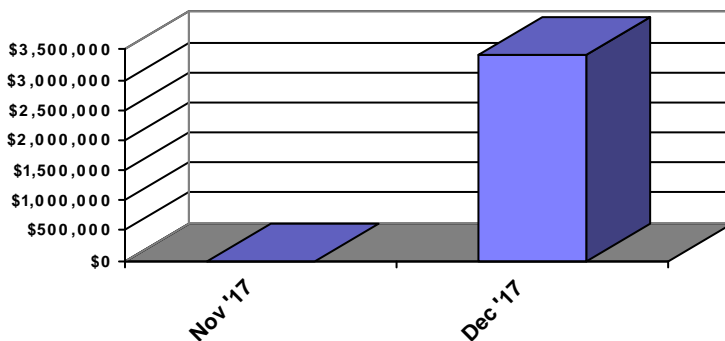

Portfolio Maturity Summary - Maturing \$/Month

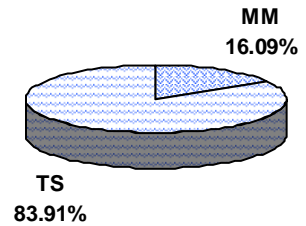

Portfolio Allocation by Transaction Type

## November 2017

### Wire Transfers

Date	From	To	Amount	For
110117	MSDLAF	Internal Revenue Service	800,830.84	10/31/17 Payroll - Federal Taxes
110117	MSDLAF	State of Minnesota	130,660.01	10/31/17 Payroll - State Taxes
110117	MSDLAF	State of Minnesota	2,157.00	10/31/17 Payroll - Child Support
110617	MSDLAF	Delta Dental	28,625.22	Dental Insurance
110817	MSDLAF	Delta Dental	9,043.77	Dental Insurance
111017	MSDLAF	PERA	118,021.34	10/31/17 Payroll - PERA
111017	MSDLAF	TRA	351,995.44	10/31/17 Payroll - TRA
111417	MSDLAF	Neopost	5,000.00	Postage
111517	MSDLAF	Delta Dental	15,132.40	Dental Insurance
111617	MSDLAF	Teacher's Federal Credit Union	40,756.60	11/15/17 Payroll - Teacher's Dues
111617	MSDLAF	People's Bank	191,535.30	11/15/17 Payroll - TSA Wire
111617	MSDLAF	State of Minnesota	2,157.00	11/15/17 Payroll - Child Support
111617	MSDLAF	TRA	352,220.84	11/15/17 Payroll - TRA
111617	MSDLAF	Internal Revenue Service	754,161.88	11/15/17 Payroll - Federal Taxes
111617	MSDLAF	State of Minnesota	124,276.20	11/15/17 Payroll - State Taxes
111617	MSDLAF	State of Minnesota	479.38	11/15/17 Garnishments
111717	MSDLAF	Wells Fargo	42,843.45	Wells Fargo Improvements to the Athletic Field at BHS
111717	MSDLAF	Healthy Savings	3,163.98	Healthy Savings Program
112017	MSDLAF	MN Department of Revenue	11.00	October Sales Tax
112217	MSDLAF	Delta Dental	12,027.23	Dental Insurance
112717	MSDLAF	PERA	119,163.56	11/15/17 Payroll - PERA
112917	MSDLAF	Delta Dental	8,165.01	Dental Insurance

## Check Register Report

Bank Number	Check Number	Check Status	Check Amount	Check Date	Vendor Number	Vendor Address Number	Vendor Name
1	1018995		\$3.37	Nov 22, 2017	88888	6452	BERG, JANET
1	1018996		\$57.19	Nov 22, 2017	88888	12301	HJERMSTAD, HEATHER
1	1018997		\$126.25	Nov 22, 2017	88888	12319	CIN, STEPHANIE P
1	1018998		\$32.84	Nov 22, 2017	88888	15745	ENGDAHL, ANN MARY
1	1018999		\$94.33	Nov 22, 2017	88888	15983	BAGGOT, LYNN
1	1019000		\$12.25	Nov 22, 2017	88888	16377	ALEXON, BETH J
1	1019001		\$38.09	Nov 22, 2017	88888	17435	LUND, ELLIOTT J
1	1019002		\$41.41	Nov 22, 2017	88888	17677	GLAS, JOHN M
1	1019003		\$28.44	Nov 22, 2017	88888	17951	BARTLING, MEGHAN
1	1019004		\$461.57	Nov 22, 2017	88888	18410	JUNGERS, GAIL
1	1019005		\$681.79	Nov 22, 2017	88888	18410	JUNGERS, GAIL
1	1019006		\$829.44	Nov 22, 2017	88888	18410	JUNGERS, GAIL
1	1019007		\$1,128.46	Nov 22, 2017	88888	18410	JUNGERS, GAIL
1	1019008		\$110.56	Nov 22, 2017	88888	6874	STEAD, AMY JO
1	1019009		\$333.79	Nov 22, 2017	88888	8937	SAMPERS, CYNTHIA
1	1019010		\$47.64	Nov 22, 2017	88888	9295	WAGNER-SMITH, SHERRY
1	1019011		\$62.60	Nov 22, 2017	88888	9670	ROBOLE, VICKI M
1	1019012		\$30.37	Nov 22, 2017	88888	10311	MATHYS, SANDRA
1	1019013		\$69.66	Nov 22, 2017	88888	10543	WURDEMAN, SCOTT
1	1019014		\$125.00	Nov 22, 2017	88888	13470	SMALLEY, AMY C
1	1019015		\$14.69	Nov 22, 2017	88888	14129	OLSEN, LAURA
1	1019016		\$81.86	Nov 22, 2017	88888	15695	THOMPSON, HYE-JEONG M
1	1019017		\$80.74	Nov 22, 2017	88888	15803	RIGGS, JEANINE L
1	1019018		\$158.42	Nov 22, 2017	88888	16491	VITALI, ALICIA F
1	1019019		\$471.95	Nov 22, 2017	88888	18090	SALMELA, KATHRYN
1	1019020		\$31.83	Nov 22,	88888	18403	REGNIER, STACY

36

## Check Register Report

Bank Number	Check Number	Check Status	Check Amount	Check Date	Vendor Number	Vendor Address Number	Vendor Name
				2017			
1	1019021		\$87.87	Nov 22, 2017	88888	18679	MEYER, JESSICA M
1	1019022		\$81.19	Nov 22, 2017	88888	18987	ROTTJAKOB, RONDA K
1	1019023		\$37.08	Nov 22, 2017	88888	19169	STRUCK, JULIE
1	1019024		\$33.87	Nov 22, 2017	88888	19257	RIVERS, JESSICA L
1	1019025		\$41.94	Nov 22, 2017	88888	19302	SCHROEDER, WENDY
1	1019026		\$287.26	Nov 29, 2017	88888	9236	LIPPKA, JONALYN
1	1019027		\$400.00	Nov 29, 2017	88888	18043	AMOROSO, CYNTHIA
1	1019028		\$4,000.00	Nov 29, 2017	88888	18114	LENHARDT, ROBERT S
1	1019029		\$200.00	Nov 29, 2017	88888	18391	JOHNSON, DOUGLAS A
1	1019030		\$81.81	Nov 29, 2017	88888	19264	KOLBO, SAMANTHA
1	1019031		\$33.64	Nov 29, 2017	88888	15856	TOUSIGNANT, HOLLY
1	1019032		\$200.00	Nov 29, 2017	88888	16166	RIDER, LISA K
1	1019033		\$16.17	Nov 29, 2017	88888	16573	WEILER, TIFFANY M
1	1019034		\$62.19	Nov 29, 2017	88888	16589	PLANTE, MARY TRACEY
1	1019035		\$12.00	Nov 29, 2017	88888	16920	YAGER, AMY LYN
1	1019036		\$30.50	Nov 29, 2017	88888	17183	VOIGT, PAMELA M
1	1019037		\$200.00	Nov 29, 2017	88888	17487	SOVINE, STACEY
1	1019038		\$7.00	Nov 29, 2017	88888	17882	VOGT, KENDRA M
1	1019039		\$88.53	Nov 29, 2017	88888	18144	MILINOVICH, TRACY
1	1019040		\$200.00	Nov 29, 2017	88888	18215	WATKINS, DAVID
1	1019041		\$34.13	Nov 29, 2017	88888	18983	SANTOS, MIYA D
1	1019042		\$200.00	Nov 29, 2017	88888	19154	PIKAL, ROBIN
1	1019043		\$15.14	Dec 6, 2017	88888	7304	GOSSMAN, LISA ANN
1	1019044		\$93.95	Dec 6, 2017	88888	9267	HOLDEN, MATTHEW J
1	1019045		\$125.00	Dec 6, 2017	88888	11357	GANDRUD, JENNIFER L
1	1019046		\$90.29	Dec 6, 2017	88888	11817	ALVEY, HEATHER
1	1019047		\$97.81	Dec 6, 2017	88888	11833	DOUGLAS, LORI

## Check Register Report

Bank Number	Check Number	Check Status	Check Amount	Check Date	Vendor Number	Vendor Address Number	Vendor Name
1	1019048		\$21.96	Dec 6, 2017	88888	11833	DOUGLAS, LORI
1	1019049		\$99.95	Dec 6, 2017	88888	12377	ANDERSON, MELISSA
1	1019050		\$71.18	Dec 6, 2017	88888	13396	HUTCHINSON, JENNIFER L
1	1019051		\$19.66	Dec 6, 2017	88888	13396	HUTCHINSON, JENNIFER L
1	1019052		\$65.80	Dec 6, 2017	88888	13425	HUBER, JON ALAN
1	1019053		\$14.45	Dec 6, 2017	88888	14183	BELLMONT, CHRISTOPHER
1	1019054		\$7.00	Dec 6, 2017	88888	14622	HARROD, KIMBERLEE N
1	1019055		\$10.17	Dec 6, 2017	88888	15682	GONZALEZ, MEGAN
1	1019056		\$60.00	Dec 6, 2017	88888	15977	HEIM, WILLIAM V
1	1019057		\$21.89	Dec 6, 2017	88888	15980	AAMODT, WILLIAM P
1	1019058		\$62.50	Dec 6, 2017	88888	16605	CRAWFORD, CINDY Y
1	1019059		\$17.12	Dec 6, 2017	88888	16605	CRAWFORD, CINDY Y
1	1019060		\$2.50	Dec 6, 2017	88888	16654	GILRAY, REBECCA J
1	1019061		\$450.92	Dec 6, 2017	88888	17175	FUNSTON, KATHY L
1	1019062		\$23.01	Dec 6, 2017	88888	17435	LUND, ELLIOTT J
1	1019063		\$57.35	Dec 6, 2017	88888	17655	JENSEN, STEVEN
1	1019064		\$2.14	Dec 6, 2017	88888	17981	BLOOD, KELSEY JO
1	1019065		\$76.80	Dec 6, 2017	88888	17983	ANDREWS, JEFFREY G
1	1019066		\$9.95	Dec 6, 2017	88888	18381	DEROUIN, JILL
1	1019067		\$13.18	Dec 6, 2017	88888	18414	KATZMAREK, ABIGAIL S
1	1019068		\$21.35	Dec 6, 2017	88888	18630	ANDERSON, JANELLE D
1	1019069		\$20.12	Dec 6, 2017	88888	19179	LATTERY, CHRISTINE
1	1019070		\$124.12	Dec 6, 2017	88888	19250	BERENS, MICHELE E
1	1019071		\$100.15	Dec 6, 2017	88888	19277	ANDERSON, LAURIE
1	1019072		\$161.04	Dec 6, 2017	88888	7268	MESARCHIK, MARY L
1	1019073		\$139.90	Dec 6, 2017	88888	10299	WEIGHTMAN, ELIZABETH C
1	1019074		\$51.44	Dec 6, 2017	88888	13470	SMALLEY, AMY C
1	1019075		\$19.90	Dec 6, 2017	88888	13905	WENDLING, PAULA L
1	1019076		\$49.46	Dec 6, 2017	88888	14130	MCCROSKEY, SHARI
1	1019077		\$18.99	Dec 6, 2017	88888	14130	MCCROSKEY, SHARI
1	1019078		\$175.70	Dec 6, 2017	88888	14453	RHINEVAULT, LYNN
1	1019079		\$32.37	Dec 6, 2017	88888	15133	MOBERG, CARLENE
1	1019080		\$62.37	Dec 6, 2017	88888	15626	PETRELLA, SARA M
1	1019081		\$56.76	Dec 6, 2017	88888	16345	WALCZAK, CHERYL M
1	1019082		\$63.13	Dec 6, 2017	88888	16669	PETTINELLI, STEPHEN M
1	1019083		\$365.38	Dec 6, 2017	88888	17183	VOIGT, PAMELA M
1	1019084		\$13.59	Dec 6, 2017	88888	18045	VO, KELLY RAE
1	1019085		\$20.00	Dec 6, 2017	88888	18305	WICK, DARRYL
1	1019086		\$53.23	Dec 6, 2017	88888	18536	SPAULDING, SHEILA J
1	1019087		\$75.76	Dec 6, 2017	88888	18677	MCLAUGHLIN, ALEXANDRA M
1	1019088		\$21.29	Dec 6, 2017	88888	18874	WHITE, ERICA E

38

## Check Register Report

Bank Number	Check Number	Check Status	Check Amount	Check Date	Vendor Number	Vendor Address Number	Vendor Name
1	1019089		\$20.98	Dec 6, 2017	88888	18909	SAYERS, KEVIN
1	1019090		\$25.15	Dec 13, 2017	88888	4467	BARLAGE, SUSAN
1	1019091		\$82.93	Dec 13, 2017	88888	7269	BARTH, TAMI RAE
1	1019092		\$37.05	Dec 13, 2017	88888	7399	GILES, SHARI M THEIS
1	1019093		\$22.10	Dec 13, 2017	88888	7847	KOLSTAD, MICHELE M
1	1019094		\$30.01	Dec 13, 2017	88888	8189	BRAUN, JEAN C
1	1019095		\$26.98	Dec 13, 2017	88888	8284	JEFFERS, LUCRETIA
1	1019096		\$217.51	Dec 13, 2017	88888	8287	KRUPKE, GRETA
1	1019097		\$31.46	Dec 13, 2017	88888	9302	BOHR, JENNIFER L
1	1019098		\$221.21	Dec 13, 2017	88888	9552	DORIGAN-SLETTE, CYNTHIA M
1	1019099		\$96.91	Dec 13, 2017	88888	11821	BLANDIN, MELISSA
1	1019100		\$24.45	Dec 13, 2017	88888	12319	CIN, STEPHANIE P
1	1019101		\$20.22	Dec 13, 2017	88888	12336	LOGAN, KARI M
1	1019102		\$9.95	Dec 13, 2017	88888	13288	LUTZ, AMANDA J
1	1019103		\$20.74	Dec 13, 2017	88888	13396	HUTCHINSON, JENNIFER L
1	1019104		\$76.29	Dec 13, 2017	88888	13495	BROWN, CHRISTOPHER M
1	1019105		\$45.74	Dec 13, 2017	88888	14751	KELLER, KATIE
1	1019106		\$56.22	Dec 13, 2017	88888	15074	CHAMERLIK, KAREN
1	1019107		\$267.91	Dec 13, 2017	88888	15999	GRIFFITHS, ROBERT H
1	1019108		\$117.51	Dec 13, 2017	88888	16244	GILBERTSON, SHERRY A
1	1019109		\$14.61	Dec 13, 2017	88888	16377	ALEXON, BETH J
1	1019110		\$168.36	Dec 13, 2017	88888	16451	LOPEZ, MARIA T
1	1019111		\$93.89	Dec 13, 2017	88888	16633	CLOUTIER, DANA M
1	1019112		\$92.50	Dec 13, 2017	88888	16789	KRONABETTER, JULIE R
1	1019113		\$12.89	Dec 13, 2017	88888	17156	BOMSTA, LYLE J
1	1019114		\$40.33	Dec 13, 2017	88888	17175	FUNSTON, KATHY L

39

## Check Register Report

Bank Number	Check Number	Check Status	Check Amount	Check Date	Vendor Number	Vendor Address Number	Vendor Name
1	1019115		\$113.15	Dec 13, 2017	88888	17216	CHOUANARD, MARY E
1	1019116		\$57.25	Dec 13, 2017	88888	17283	ERBES, SARAH L
1	1019117		\$60.00	Dec 13, 2017	88888	17333	JONES, GARY A
1	1019118		\$7.22	Dec 13, 2017	88888	17742	BUCK, REBECCA L
1	1019119		\$20.87	Dec 13, 2017	88888	17819	ABRAHAMSON, JONATHAN
1	1019120		\$11.97	Dec 13, 2017	88888	17901	KENNEY, JAMI
1	1019121		\$6.96	Dec 13, 2017	88888	17981	BLOOD, KELSEY JO
1	1019122		\$36.38	Dec 13, 2017	88888	18388	JORGENSEN, STEPHANIE
1	1019123		\$95.08	Dec 13, 2017	88888	18671	KOHN, GRACE
1	1019124		\$44.14	Dec 13, 2017	88888	18691	GULDEN, JANET
1	1019125		\$78.93	Dec 13, 2017	88888	18943	HUGHES, RACHEL J
1	1019126		\$71.32	Dec 13, 2017	88888	18952	CSELOVSZKI, CASSANDRA K
1	1019127		\$79.55	Dec 13, 2017	88888	19183	BECQUER, FRANCES
1	1019128		\$126.74	Dec 13, 2017	88888	4356	SIMON, GLENN D.
1	1019129		\$10.00	Dec 13, 2017	88888	7300	ROSSINI, CATHERINE L
1	1019130		\$8.67	Dec 13, 2017	88888	7347	SMITH, KELLY L
1	1019131		\$14.98	Dec 13, 2017	88888	8281	PLASCHKO, MARY BETH
1	1019132		\$472.75	Dec 13, 2017	88888	9216	MEYER, NANCY L
1	1019133		\$74.95	Dec 13, 2017	88888	9239	OPATZ, LARRY
1	1019134		\$11.34	Dec 13, 2017	88888	10287	TANBERG, TERESA L
1	1019135		\$298.00	Dec 13, 2017	88888	12488	SCHUUR, MYRON G
1	1019136		\$12.00	Dec 13, 2017	88888	12853	MATERNOWSKI, PATRICIA
1	1019137		\$44.83	Dec 13, 2017	88888	12869	SCHEIT, ANDREA
1	1019138		\$14.00	Dec 13, 2017	88888	13074	MARTINEZ, ROBERT V
1	1019139		\$33.17	Dec 13, 2017	88888	13905	WENDLING, PAULA L
1	1019140		\$84.90	Dec 13,	88888	15010	NELSON, KATIE L

40

## Check Register Report

Bank Number	Check Number	Check Status	Check Amount	Check Date	Vendor Number	Vendor Address Number	Vendor Name
				2017			
1	1019141		\$109.00	Dec 13, 2017	88888	15691	RUZICHKA, LAURIE J
1	1019142		\$96.30	Dec 13, 2017	88888	15695	THOMPSON, HYE-JEONG M
1	1019143		\$24.02	Dec 13, 2017	88888	15700	REID, LISA M
1	1019144		\$257.87	Dec 13, 2017	88888	15911	WILLSON, DAWN M
1	1019145		\$15.35	Dec 13, 2017	88888	16003	PRANSCHKE, STEPHANIE T
1	1019146		\$176.02	Dec 13, 2017	88888	16213	STAHLY, JANICE
1	1019147		\$11.07	Dec 13, 2017	88888	17719	NIERENGARTEN, BRIANNA L
1	1019148		\$175.68	Dec 13, 2017	88888	18612	MALLINGER, MELINDA
1	1019149		\$37.02	Dec 13, 2017	88888	18624	ROEHL, PETER A
1	1019150		\$24.34	Dec 13, 2017	88888	18635	MCDOWELL, MORGAN
1	1019151		\$48.09	Dec 13, 2017	88888	18697	THEIS, RACHAEL L
1	1019152		\$54.36	Dec 13, 2017	88888	18846	OTTO, CARON
1	1019153		\$139.31	Dec 13, 2017	88888	19203	STAMPLEY, MORGAN
1	1019154		\$15.85	Dec 13, 2017	88888	19222	ULRICH, JULIA
1	1019155		\$12.21	Dec 13, 2017	88888	19302	SCHROEDER, WENDY
<b>Check Count</b>	<b>161</b>	<b>Grand Total</b>	<b>\$19,625.03</b>				

41

## Check Register Report

Bank Number	Check Number	Check Status	Check Amount	Check Date	Vendor Number	Vendor Address Number	Vendor Name
4	456005	Clear	\$206.00	Nov 17, 2017	02623	1	ACCO BRANDS USA LLC
4	456006	Clear	\$256.00	Nov 17, 2017	27125	0	ALLEN, DARIEL J.
4	456007		\$171.00	Nov 17, 2017	29623	0	ANDERSON, SUZANNE
4	456008	Clear	\$1,406.08	Nov 17, 2017	00075	4	ANOKA HENNEPIN SCHOOL DISTRICT #11
4	456009	Clear	\$137.75	Nov 17, 2017	29626	0	BALDWIN, SHARON
4	456010	Clear	\$10,586.20	Nov 17, 2017	03544	2	BEST BUY BUSINESS ADVANTAGE ACCOUNT
4	456011	Clear	\$1,577.40	Nov 17, 2017	29008	0	BIG FROG CUSTOM T-SHIRTS
4	456012	Clear	\$204.75	Nov 17, 2017	29628	0	BOE, STEVEN
4	456013	Clear	\$144.88	Nov 17, 2017	29111	0	BONNER HALL, DAWN
4	456014	Clear	\$189.00	Nov 17, 2017	29097	0	BOODOO, ROOPNARINE
4	456015	Clear	\$87.88	Nov 17, 2017	25258	0	BORCHART, LAUREN
4	456016	Clear	\$350.00	Nov 17, 2017	27894	0	BURNSVILLE NORDIC SKI BOOSTERS
4	456017	Clear	\$189.00	Nov 17, 2017	29101	0	BUSHLACK, DAVID
4	456018	Clear	\$142.50	Nov 17, 2017	29102	0	BUSHLACK, MARGARET
4	456019		\$90.00	Nov 17, 2017	22414	0	CARLSON, ASHLEIGH
4	456020		\$40.00	Nov 17, 2017	29343	0	CARSON, WENDY
4	456021	Clear	\$754.50	Nov 17, 2017	28973	0	CASPERSON, JULIE
4	456022		\$60.00	Nov 17, 2017	28260	0	CHOY, SERGIO R.
4	456023		\$66.50	Nov 17, 2017	27870	0	CLAUDE, JAMES
4	456024	Clear	\$264.00	Nov 17, 2017	27274	0	COMPUTER EXPLORERS
4	456025	Clear	\$3,343.07	Nov 17, 2017	06231	0	CONSOLIDATED COMMUNICATIONS
4	456026	Clear	\$60.00	Nov 17, 2017	25919	0	CORDOVA, LETICIA
4	456027	Clear	\$73,509.90	Nov 17, 2017	00809	0	DAKOTA ELECTRIC ASSOCIATION
4	456028	Clear	\$600.00	Nov 17, 2017	00875	0	DRAMATISTS PLAY SERVICE INC.
4	456029	Clear	\$4,606.56	Nov 17, 2017	01928	0	EASTERN CARVER COUNTY SCHOOLS
4	456030	Clear	\$142.50	Nov 17,	29624	0	EASTMAN, LARRY

42

## Check Register Report

Bank Number	Check Number	Check Status	Check Amount	Check Date	Vendor Number	Vendor Address Number	Vendor Name
				2017			
4	456031		\$131.00	Nov 17, 2017	28531	0	EDUCATION MINNESOTA
4	456032	Clear	\$189.00	Nov 17, 2017	29627	0	FANCHER, DUANE
4	456033	Clear	\$152.00	Nov 17, 2017	01382	0	FINN, STEVE
4	456034	Clear	\$204.75	Nov 17, 2017	29629	0	GLOVER, WILLIAM
4	456035	Clear	\$144.88	Nov 17, 2017	29631	0	GRASS, LOUISE
4	456036	Clear	\$122.00	Nov 17, 2017	27604	0	GREAT LAKES HIGHER EDUCATION CORPORATION
4	456037	Clear	\$2,460.68	Nov 17, 2017	07139	0	HASTINGS BUS COMPANY
4	456038		\$199.50	Nov 17, 2017	04407	0	HAUGEN, CLARE
4	456039	Clear	\$189.00	Nov 17, 2017	29115	0	HAYES, JAMES
4	456040	Clear	\$2,425.00	Nov 17, 2017	24481	0	HOIGAARD'S CUSTOM CANVAS & AWNINGS, LLC
4	456041		\$140.00	Nov 17, 2017	29182	0	HUTSAL, OLEKSANDRA
4	456042	Clear	\$10,815.00	Nov 17, 2017	28876	0	IMAGINE DESIGN & CREATIVE CONSULTING, INC
4	456043		\$13,647.85	Nov 17, 2017	08893	4	IND. SCHOOL DIST. 1
4	456044	Clear	\$6,044.58	Nov 17, 2017	01904	0	IND. SCHOOL DIST. 12
4	456045		\$2,325.76	Nov 17, 2017	04692	0	IND. SCHOOL DIST. 2144
4	456046	Clear	\$1,380.00	Nov 17, 2017	07462	1	IND. SCHOOL DIST. 709
4	456047	Clear	\$7,649.94	Nov 17, 2017	03036	1	IND. SCHOOL DIST. 742
4	456048	Clear	\$1,809.20	Nov 17, 2017	09327	0	INTERMEDIATE SCHOOL DISTRICT 917
4	456049	Clear	\$99.75	Nov 17, 2017	29630	0	JACKSON, DYLAN
4	456050	Clear	\$345.00	Nov 17, 2017	24542	0	JAMA, SAFIYO
4	456051		\$168.00	Nov 17, 2017	29479	0	JAMERSON, FELICIA
4	456052	Clear	\$210.00	Nov 17, 2017	20523	0	JONES, SCOTT
4	456053		\$80.00	Nov 17, 2017	26282	0	LEE, WAI YEE
4	456054	Clear	\$142.50	Nov 17, 2017	29625	0	LUCY, LUCY ANN
4	456055	Clear	\$95.00	Nov 17, 2017	29612	0	MADSEN, KIRA

43

## Check Register Report

Bank Number	Check Number	Check Status	Check Amount	Check Date	Vendor Number	Vendor Address Number	Vendor Name
4	456056	Clear	\$104.50	Nov 17, 2017	29613	0	MARTIN, SUSAN E.
4	456057	Clear	\$99.75	Nov 17, 2017	29614	0	MCPMAHON, SHEALYN
4	456058	Clear	\$211.68	Nov 17, 2017	06064	0	MEEKER AND WRIGHT SPECIAL
4	456059	Clear	\$140.13	Nov 17, 2017	29615	0	MESHAR, AVI
4	456060		\$400.00	Nov 17, 2017	08865	20	METRO ECSU - MINNESOTA DB PROJECT
4	456061	Clear	\$12,235.00	Nov 17, 2017	08543	9	MN DEPT OF HEALTH
4	456062	Unissued	\$0.00	Nov 17, 2017	08543	9	MN DEPT OF HEALTH
4	456063	Clear	\$1,585.00	Nov 17, 2017	02538	0	MN ELEMENTARY SCHOOL PRINCIPALS ASSOC (MESPA)
4	456064	Clear	\$4,196.00	Nov 17, 2017	02445	0	MN STATE HIGH SCHOOL LEAGUE (MSHSL)
4	456065	Clear	\$199.50	Nov 17, 2017	29616	0	MORRISON, LEROY BRYAN
4	456066		\$25.00	Nov 17, 2017	05320	10	MRPA/MASS
4	456067	Clear	\$1,176.25	Nov 17, 2017	22324	0	MULTILINGUAL WORD, INC.
4	456068	Clear	\$99.75	Nov 17, 2017	29617	0	NISTLER, JACOB
4	456069	Clear	\$53.27	Nov 17, 2017	02765	0	NORCOSTCO, INC.
4	456070	Clear	\$476.39	Nov 17, 2017	00766	0	NORTHFIELD LINES, INC.
4	456071		\$240.00	Nov 17, 2017	24879	0	PEREZ, MELISSA M.
4	456072	Clear	\$90.25	Nov 17, 2017	29618	0	PREISINGER, TIFFANY
4	456073		\$189.00	Nov 17, 2017	29127	0	PROCACCINI, ROBERT J.
4	456074		\$75.00	Nov 17, 2017	24681	0	PROFESSIONAL WIRELESS COMMUNICATIONS
4	456075		\$11,250.00	Nov 17, 2017	24635	0	SAN DIEGO COUNTY OFFICE OF EDUCATION
4	456076	Clear	\$140.13	Nov 17, 2017	03403	0	SCHMIDT, FRAN
4	456077	Clear	\$147.25	Nov 17, 2017	29619	0	SCHMIDT, NELSON
4	456078	Clear	\$686.52	Nov 17, 2017	03532	2	SCHMITT MUSIC
4	456079	Clear	\$285.00	Nov 17, 2017	26552	3	SCHOOL NUTRITION ASSOCIATION
4	456080	Clear	\$452.80	Nov 17, 2017	29500	0	SHERBURNE NOTHERN WRIGHT SPECIAL EDUCATION
4	456081	Clear	\$400.00	Nov 17,	29633	0	SMITH, FRANK CHARLES

44

## Check Register Report

Bank Number	Check Number	Check Status	Check Amount	Check Date	Vendor Number	Vendor Address Number	Vendor Name
				2017			
4	456082	Clear	\$1,533.24	Nov 17, 2017	28611	0	SOUTHWEST METRO INTERMEDIATE
4	456083		\$99.75	Nov 17, 2017	29620	0	STUART, MADELINE
4	456084		\$705.25	Nov 17, 2017	27465	0	SUMMER, JULIE ANNA
4	456085	Clear	\$2,625.05	Nov 17, 2017	28502	0	THE MCDOWELL AGENCY, INC.
4	456086	Clear	\$90.25	Nov 17, 2017	29621	0	TORRES, DANIEL
4	456087		\$51.00	Nov 17, 2017	29632	0	TUFA, FURO
4	456088	Clear	\$60.00	Nov 17, 2017	25958	0	UGAS, ABDISAMAD
4	456089	Clear	\$194.00	Nov 17, 2017	02813	7	US DEPARTMENT OF EDUCATION
4	456090	Clear	\$140.13	Nov 17, 2017	23080	0	USCHOLD WINKER, MARIE
4	456091		\$102.13	Nov 17, 2017	29622	0	WEDAN, ROBERT
4	456092	Clear	\$10,300.24	Nov 22, 2017	28551	0	ADVANCED IMAGING SOLUTIONS
4	456093	Clear	\$137.50	Nov 22, 2017	06215	0	AIRPORT TAXI, INC.
4	456094		\$102.00	Nov 22, 2017	28727	0	ALY, ZAKARIA
4	456095	Clear	\$150.00	Nov 22, 2017	29637	0	ANDERSON, ANTHONY
4	456096		\$282.00	Nov 22, 2017	29634	0	APEX FUN RUN
4	456097		\$149.00	Nov 22, 2017	28689	0	ARRIGONI, BRIAN
4	456098	Clear	\$335.70	Nov 22, 2017	00386	1	BARNES & NOBLE, INC.
4	456099		\$128.00	Nov 22, 2017	29642	0	BARRETT, MEGAN RAE
4	456100	Clear	\$300.00	Nov 22, 2017	01740	0	BHS ALPINE SKI TEAM BOOSTER
4	456101		\$300.00	Nov 22, 2017	09039	0	BHS SWIM BOOSTER CLUB
4	456102	Clear	\$128.00	Nov 22, 2017	29649	0	BRION, OLIVIA
4	456103		\$450.00	Nov 22, 2017	25473	0	BUESGENS, KELLY
4	456104		\$300.00	Nov 22, 2017	03719	0	BURNSVILLE GIRLS BASKETBALL BOOSTERS
4	456105		\$23,175.00	Nov 22, 2017	00673	0	BURNSVILLE, CITY OF
4	456106	Clear	\$325.00	Nov 22, 2017	00673	0	BURNSVILLE, CITY OF

45

## Check Register Report

Bank Number	Check Number	Check Status	Check Amount	Check Date	Vendor Number	Vendor Address Number	Vendor Name
4	456107	Clear	\$130.80	Nov 22, 2017	00483	0	CASSIDY-TRICKER INDUSTRIAL SALES, INC.
4	456108		\$5,085.78	Nov 22, 2017	02519	0	CENTERPOINT ENERGY
4	456109		\$165.00	Nov 22, 2017	28260	0	CHOY, SERGIO R.
4	456110		\$173.00	Nov 22, 2017	29648	0	CHRISTENSEN, COLLEEN
4	456111	Clear	\$208.50	Nov 22, 2017	00000	2030	CHRISTENSEN, MARYBETH
4	456112	Clear	\$128.00	Nov 22, 2017	20211	0	CLAPP, DEBORAH
4	456113	Clear	\$180.00	Nov 22, 2017	25919	0	CORDOVA, LETICIA
4	456114		\$183.00	Nov 22, 2017	00502	0	CORNERSTONE COPY CENTER
4	456115	Clear	\$265.00	Nov 22, 2017	00666	1	COUNCIL FOR EXCEPTIONAL CHILDREN
4	456116	Clear	\$84.00	Nov 22, 2017	26492	0	CUNDY, BRODIE
4	456117		\$4,122.00	Nov 22, 2017	28385	0	CYPRUS CLASSICAL ACADEMY
4	456118	Clear	\$360.00	Nov 22, 2017	20524	0	DEWALD, RINA C.
4	456119	Clear	\$360.00	Nov 22, 2017	29581	0	DORE, ABDIWALI HASHI
4	456120	Clear	\$562,712.53	Nov 22, 2017	28300	1	DURHAM SCHOOL SERVICES
4	456121		\$149.00	Nov 22, 2017	20644	0	FREY, DAVE
4	456122		\$65.00	Nov 22, 2017	27222	0	GRAMS, RILEY
4	456123	Clear	\$128.00	Nov 22, 2017	29647	0	HARDING, LAURA
4	456124		\$173.00	Nov 22, 2017	26933	0	HART, LISA
4	456125		\$130.00	Nov 22, 2017	02281	1	HASTINGS HIGH SCHOOL
4	456126	Clear	\$149.00	Nov 22, 2017	23542	0	HENDRICKSON, JEREMY
4	456127	Clear	\$82.50	Nov 22, 2017	24867	0	IBAR, AMINA
4	456128	Clear	\$175.00	Nov 22, 2017	20540	0	INTELLIGERE, INC
4	456129		\$128.00	Nov 22, 2017	25330	0	JENKINS, LAUREN
4	456130	Clear	\$128.00	Nov 22, 2017	29646	0	JEWISON, JAMIE
4	456131	Clear	\$225.00	Nov 22, 2017	29645	0	JILEK, SCOTT
4	456132		\$180.00	Nov 22,	29582	0	JOHNSON, BRETT

46

## Check Register Report

Bank Number	Check Number	Check Status	Check Amount	Check Date	Vendor Number	Vendor Address Number	Vendor Name
				2017			
4	456133	Clear	\$64.50	Nov 22, 2017	25365	0	JOHNSON, KATE
4	456134	Clear	\$1,032.00	Nov 22, 2017	29424	1	K12 MANAGEMENT
4	456135	Clear	\$180.00	Nov 22, 2017	23607	0	KENNEY, PATRICK
4	456136	Clear	\$128.00	Nov 22, 2017	29644	0	LARSON, MELANIE
4	456137	Clear	\$14.62	Nov 22, 2017	00016	1864	LINK, CLARE
4	456138	Clear	\$1,175.64	Nov 22, 2017	28903	0	LITURGICAL PUBLICATIONS, INC.
4	456139	Clear	\$603.00	Nov 22, 2017	05077	0	LOCKSAFE INC.
4	456140	Clear	\$1,000.00	Nov 22, 2017	28387	0	LUTHER COLLEGE
4	456141		\$64.50	Nov 22, 2017	29643	0	LYNCH, HEATHER
4	456142	Clear	\$149.00	Nov 22, 2017	27488	0	MARCOTTE, DAVE
4	456143	Clear	\$68.00	Nov 22, 2017	08647	0	MARSHALL, JAMES
4	456144		\$180.00	Nov 22, 2017	29638	0	MEIER, LISA
4	456145		\$100.00	Nov 22, 2017	26315	0	METRO COMMUNITY ED. DIRECTORS ASSN.
4	456146		\$3,986.14	Nov 22, 2017	28476	0	METROPOLITAN STATE UNIVERSITY
4	456147	Clear	\$221.55	Nov 22, 2017	24060	0	MEYER, RITA
4	456148	Clear	\$1,539.15	Nov 22, 2017	03029	1	MINNESOTA ENERGY RESOURCES
4	456149		\$360.00	Nov 22, 2017	29160	0	MINNESOTA QUIZ BOWL ALLIANCE (MQBA)
4	456150	Clear	\$325.00	Nov 22, 2017	02613	0	MN ZOO
4	456151	Clear	\$300.00	Nov 22, 2017	24243	0	MUNOZ, MARIBEL
4	456152	Clear	\$6,253.76	Nov 22, 2017	24335	1	NEW DOMINION SCHOOL
4	456153		\$11,900.00	Nov 22, 2017	26075	0	NEXUS SOLUTIONS, LLC
4	456154		\$600.00	Nov 22, 2017	29605	0	NIMMO, VIRGINIA
4	456155	Clear	\$64.50	Nov 22, 2017	29639	0	PENNER, MELISSA
4	456156		\$120.00	Nov 22, 2017	24879	0	PEREZ, MELISSA M.
4	456157	Clear	\$39.00	Nov 22, 2017	00000	9245	PERRY, TERESA

47

## Check Register Report

Bank Number	Check Number	Check Status	Check Amount	Check Date	Vendor Number	Vendor Address Number	Vendor Name
4	456158	Clear	\$64.50	Nov 22, 2017	29640	0	RAMM, HOLLY
4	456159		\$2,896.00	Nov 22, 2017	29635	0	RESPONDUS
4	456160	Clear	\$80.00	Nov 22, 2017	08220	0	ROCHESTER MAYO HIGH SCHOOL
4	456161	Clear	\$30.08	Nov 22, 2017	00000	688	SCHIPRETT, JIM
4	456162	Clear	\$113,441.56	Nov 22, 2017	09331	0	SCHMITTY & SONS SCHOOL BUSES, INC.
4	456163	Clear	\$3,407.00	Nov 22, 2017	27933	2	SCHNEIDER ELECTRIC IT USA INC
4	456164		\$128.00	Nov 22, 2017	26937	0	SCHNEIDER-KRUMPUS, FRANZISKA
4	456165	Clear	\$1,837.75	Nov 22, 2017	03587	1	SIMPLEX GRINNELL
4	456166		\$807.50	Nov 22, 2017	29575	0	SKOW, KAREN
4	456167		\$1,721.57	Nov 22, 2017	29636	0	SOMOS ONE VOICE
4	456168	Clear	\$128.00	Nov 22, 2017	20625	0	SORBEL, STEPHANIE
4	456169	Clear	\$106.60	Nov 22, 2017	21190	0	TROUSIL, WANDA
4	456170	Clear	\$2,056.00	Nov 22, 2017	28417	0	UNIVERSAL ATHLETIC SERVICE INC.
4	456171	Clear	\$35,297.53	Nov 22, 2017	04417	1	US FOODS INC
4	456172	Unissued	\$0.00	Nov 22, 2017	04417	1	US FOODS INC
4	456173	Unissued	\$0.00	Nov 22, 2017	04417	1	US FOODS INC
4	456174	Clear	\$279.00	Nov 22, 2017	29641	0	VIZENOR, JEFF
4	456175	Clear	\$595.00	Nov 22, 2017	25073	0	WEST 44TH STREET GRAPHICS
4	456176		\$60.00	Nov 22, 2017	25837	0	WILLIAMS, REBECCA
4	456177		\$2,000.00	Nov 28, 2017	00778	0	ARMSTRONG, MAUREEN
4	456178		\$340.00	Nov 28, 2017	09426	0	ARNESON, AL
4	456179		\$890.50	Nov 28, 2017	22108	0	AYAQUICA, SHERI
4	456180		\$240.00	Nov 28, 2017	00722	3	BLOOMINGTON JEFFERSON HIGH SCHOOL
4	456181		\$1,932.58	Nov 28, 2017	05944	0	BURNSVILLE SWIM CLUB, INC.
4	456182		\$718.39	Nov 28, 2017	00673	0	BURNSVILLE, CITY OF
4	456183		\$5,600.00	Nov 28,	21968	0	CEL PUBLIC RELATIONS, INC.

48

## Check Register Report

Bank Number	Check Number	Check Status	Check Amount	Check Date	Vendor Number	Vendor Address Number	Vendor Name
				2017			
4	456184		\$359.00	Nov 28, 2017	08621	1	CHILDREN'S THEATRE COMPANY
4	456185		\$428.75	Nov 28, 2017	00502	0	CORNERSTONE COPY CENTER
4	456186		\$1,374.10	Nov 28, 2017	09654	0	COSTUME RENTALS
4	456187		\$5,915.25	Nov 28, 2017	29385	0	DIGITAL INSURANCE, INC.
4	456188		\$105.32	Nov 28, 2017	28202	0	FOUNDATION 191
4	456189		\$297.00	Nov 28, 2017	04248	0	GEYEN, JULIE
4	456190		\$1,051.10	Nov 28, 2017	20744	0	GOPHER STATE EVENTS, LLC
4	456191		\$7.19	Nov 28, 2017	00575	0	GROTH MUSIC COMPANY
4	456192		\$150.00	Nov 28, 2017	22902	0	HENRY, LAWRENCE
4	456193		\$2,550.00	Nov 28, 2017	24432	0	I GOT SKILLS
4	456194		\$25.00	Nov 28, 2017	01880	3	IND. SCHOOL DIST. 194 - LAKEVILLE SOUTH
4	456195		\$58,416.22	Nov 28, 2017	27633	0	KELLY SERVICES, INC.
4	456196		\$528.08	Nov 28, 2017	26743	0	KIDCREATE STUDIO
4	456197		\$175.00	Nov 28, 2017	08543	7	MN DEPT OF HEALTH
4	456198		\$300.00	Nov 28, 2017	03164	0	MN MUSIC EDUCATORS ASSOCIATION (MMEA)
4	456199		\$248.40	Nov 28, 2017	09589	2	NEOPOST USA INC
4	456200		\$101.74	Nov 28, 2017	02489	1	OFFICE DEPOT COMPANY
4	456201		\$2,729.72	Nov 28, 2017	06477	0	OFFICE OF MN IT SERVICES
4	456202		\$1,272.40	Nov 28, 2017	24471	0	OPG-3 INC.
4	456203		\$738.00	Nov 28, 2017	24681	0	PROFESSIONAL WIRELESS COMMUNICATIONS
4	456204		\$3,000.00	Nov 28, 2017	25725	0	PROJECT LEAD THE WAY
4	456205		\$10.00	Nov 28, 2017	00016	1336	RIPPENTROP, JASON
4	456206	Clear	\$42.83	Nov 28, 2017	03532	2	SCHMITT MUSIC
4	456207		\$1,608.33	Nov 28, 2017	03587	1	SIMPLEX GRINNELL
4	456208	Clear	\$189.30	Nov 28, 2017	03802	0	TRIO SUPPLY

49

## Check Register Report

Bank Number	Check Number	Check Status	Check Amount	Check Date	Vendor Number	Vendor Address Number	Vendor Name
4	456209		\$16.99	Nov 28, 2017	21190	0	TROUSIL, WANDA
4	456210		\$80.00	Nov 28, 2017	24490	0	UPPER MISSISSIPPI IRRIGATION
4	456211		\$5,372.00	Nov 28, 2017	01197	1	US FOODS CULINARY EQUIPMENT & SUPPLIES LLC
4	456212	Clear	\$16,207.45	Nov 28, 2017	04417	1	US FOODS INC
4	456213	Unissued	\$0.00	Nov 28, 2017	04417	1	US FOODS INC
4	456214		\$7,842.89	Dec 1, 2017	28491	0	A.J. MOORE ELECTRIC, INC.
4	456215		\$3,543.20	Dec 1, 2017	29434	0	ACER SERVICE CORPORATION
4	456216		\$10,744.52	Dec 1, 2017	28147	1	AGROPUR INC. DIVISION NATREL USA
4	456217	Unissued	\$0.00	Dec 1, 2017	28147	1	AGROPUR INC. DIVISION NATREL USA
4	456218	Unissued	\$0.00	Dec 1, 2017	28147	1	AGROPUR INC. DIVISION NATREL USA
4	456219	Unissued	\$0.00	Dec 1, 2017	28147	1	AGROPUR INC. DIVISION NATREL USA
4	456220	Unissued	\$0.00	Dec 1, 2017	28147	1	AGROPUR INC. DIVISION NATREL USA
4	456221	Unissued	\$0.00	Dec 1, 2017	28147	1	AGROPUR INC. DIVISION NATREL USA
4	456222	Unissued	\$0.00	Dec 1, 2017	28147	1	AGROPUR INC. DIVISION NATREL USA
4	456223	Unissued	\$0.00	Dec 1, 2017	28147	1	AGROPUR INC. DIVISION NATREL USA
4	456224		\$1,138.00	Dec 1, 2017	28566	0	AHERN, PATRICK
4	456225		\$2,155.04	Dec 1, 2017	27586	0	AMERICAN OFFICE PRODUCTS
4	456226		\$1,830.54	Dec 1, 2017	03503	0	AMERICAN TIME & SIGNAL
4	456227		\$174.36	Dec 1, 2017	01365	0	AMERIPRIDE LINEN AND APPAREL SERVICES
4	456228		\$3,550.00	Dec 1, 2017	00145	0	APACHE GROUP
4	456229		\$4,800.00	Dec 1, 2017	00106	0	AQUA ENGINEERING, INC.
4	456230		\$279.80	Dec 1, 2017	23412	1	B&H PHOTO-VIDEO
4	456231		\$1,196.84	Dec 1, 2017	00386	1	BARNES & NOBLE, INC.
4	456232	Unissued	\$0.00	Dec 1, 2017	00386	1	BARNES & NOBLE, INC.
4	456233		\$8,354.99	Dec 1, 2017	03544	2	BEST BUY BUSINESS ADVANTAGE ACCOUNT
4	456234		\$648.00	Dec 1,	21117	0	BIO CORPORATION

50

## Check Register Report

Bank Number	Check Number	Check Status	Check Amount	Check Date	Vendor Number	Vendor Address Number	Vendor Name
				2017			
4	456235		\$12,098.48	Dec 1, 2017	00477	0	BIX PRODUCE COMPANY
4	456236	Unissued	\$0.00	Dec 1, 2017	00477	0	BIX PRODUCE COMPANY
4	456237	Unissued	\$0.00	Dec 1, 2017	00477	0	BIX PRODUCE COMPANY
4	456238	Unissued	\$0.00	Dec 1, 2017	00477	0	BIX PRODUCE COMPANY
4	456239	Unissued	\$0.00	Dec 1, 2017	00477	0	BIX PRODUCE COMPANY
4	456240	Unissued	\$0.00	Dec 1, 2017	00477	0	BIX PRODUCE COMPANY
4	456241		\$3,840.53	Dec 1, 2017	26720	0	BLUE BELL ENTERPRISES, INC.
4	456242		\$11,986.43	Dec 1, 2017	29306	0	C.G.T. LIMITED
4	456243		\$2,368.75	Dec 1, 2017	00707	1	CARRIER CORPORATION
4	456244		\$12,270.12	Dec 1, 2017	20289	1	CDW GOVERNMENT, INC.
4	456245		\$218.85	Dec 1, 2017	05251	1	CHANNING BETE COMPANY, INC.
4	456246		\$42,700.00	Dec 1, 2017	22015	0	CM CONSTRUCTION COMPANY, INC.
4	456247		\$457.24	Dec 1, 2017	03866	0	CONTINENTAL CLAY COMPANY
4	456248		\$6,735.65	Dec 1, 2017	23509	0	COOL AIR MECHANICAL, INC.
4	456249		\$138.00	Dec 1, 2017	00647	0	CROWN RENTAL, INC.
4	456250		\$64.67	Dec 1, 2017	00645	0	CUB FOODS
4	456251		\$8,010.69	Dec 1, 2017	00782	1	CURRICULUM ASSOCIATES, INC.
4	456252		\$10,543.22	Dec 1, 2017	04186	1	DALCO
4	456253	Unissued	\$0.00	Dec 1, 2017	04186	1	DALCO
4	456254	Unissued	\$0.00	Dec 1, 2017	04186	1	DALCO
4	456255		\$48.49	Dec 1, 2017	09859	1	DISCOUNT SCHOOL SUPPLY
4	456256		\$7,628.18	Dec 1, 2017	00279	0	DIVERSIFIED SNACK DISTRIBUTION
4	456257	Unissued	\$0.00	Dec 1, 2017	00279	0	DIVERSIFIED SNACK DISTRIBUTION
4	456258		\$335.00	Dec 1, 2017	24933	0	DURAND MANUFACTURING, INC.
4	456259		\$1,786.85	Dec 1, 2017	01078	0	ELECTRO WATCHMAN, INC.

51

## Check Register Report

Bank Number	Check Number	Check Status	Check Amount	Check Date	Vendor Number	Vendor Address Number	Vendor Name
4	456260		\$919.00	Dec 1, 2017	26949	0	FAIRFIELD GLASS & WINDOW, INC.
4	456261		\$127.09	Dec 1, 2017	24391	1	FUN EXPRESS, LLC
4	456262		\$5,799.66	Dec 1, 2017	01541	1	GENERAL PARTS, LLC
4	456263	Unissued	\$0.00	Dec 1, 2017	01541	1	GENERAL PARTS, LLC
4	456264		\$219.90	Dec 1, 2017	27736	0	GLOBAL COMMUNICATIONS WIRING & SERVICES
4	456265		\$818.09	Dec 1, 2017	04387	1	GRAINGER
4	456266	Unissued	\$0.00	Dec 1, 2017	04387	1	GRAINGER
4	456267		\$148.95	Dec 1, 2017	22358	0	HEINZ DISPENSING SOLUTIONS
4	456268		\$1,518.02	Dec 1, 2017	09046	0	HI TECH REFRIGERATION, INC
4	456269		\$423.50	Dec 1, 2017	01622	0	HOBART SERVICE
4	456270		\$287.17	Dec 1, 2017	04818	0	HORIZON COMMERCIAL POOL SUPPLY
4	456271		\$12,848.20	Dec 1, 2017	01324	0	HORIZON EQUIPMENT, LLC
4	456272		\$3,034.45	Dec 1, 2017	27693	0	IDEAL SERVICES, INC.
4	456273		\$23.20	Dec 1, 2017	28877	0	INTERSTATE ALL BATTERY CENTER
4	456274		\$68.57	Dec 1, 2017	01134	0	JIM COOPERS TIRE & AUTO STORES
4	456275		\$15,453.00	Dec 1, 2017	28688	0	K12 TRANSPORTATION MANAGEMENT SERVICES, INC.
4	456276	Void	\$10.08	Dec 1, 2017	01434	0	KULLY SUPPLY, INC.
4	456277		\$275.00	Dec 1, 2017	05077	0	LOCKSAFE INC.
4	456278		\$665.93	Dec 1, 2017	02196	0	MACKIN EDUCATIONAL RESOURCES
4	456279		\$1,361.09	Dec 1, 2017	07752	0	MILLER ELECTRIC, INC.
4	456280		\$124.50	Dec 1, 2017	08999	1	MINNESOTA ELEVATOR INC
4	456281		\$4,657.30	Dec 1, 2017	27702	0	MORCON CONSTRUCTION INC.
4	456282		\$261.75	Dec 1, 2017	03519	0	NAPA AUTO PARTS
4	456283		\$615.60	Dec 1, 2017	26298	4	NCS PEARSON
4	456284		\$96.85	Dec 1, 2017	25372	4	NCS PEARSON INC
4	456285		\$7.79	Dec 1,	02489	1	OFFICE DEPOT COMPANY

52

## Check Register Report

Bank Number	Check Number	Check Status	Check Amount	Check Date	Vendor Number	Vendor Address Number	Vendor Name
				2017			
4	456286		\$190.00	Dec 1, 2017	27700	0	OLYMPIC COMMUNICATIONS INC.
4	456287		\$1,960.00	Dec 1, 2017	03757	0	PALMER WEST CONSTRUCTION COMPANY, INC.
4	456288		\$1,743.75	Dec 1, 2017	28310	1	POWER SECURE
4	456289		\$217.80	Dec 1, 2017	03073	1	PRO-ED
4	456290		\$162.84	Dec 1, 2017	28785	1	PRODOCON, INC
4	456291		\$890.75	Dec 1, 2017	25729	0	RENT N' SAVE PORTABLE SERVICES
4	456292		\$60.00	Dec 1, 2017	28528	0	ROCK HARD LANDSCAPE SUPPLY
4	456293		\$124.00	Dec 1, 2017	28241	0	SOCIAL THINKING PUBLISHING
4	456294		\$278.76	Dec 1, 2017	03689	0	STATE SUPPLY CO., INC.
4	456295		\$218.00	Dec 1, 2017	23998	2	SUMMIT COMMERCIAL FACILITIES GROUP
4	456296		\$88.96	Dec 1, 2017	01377	0	THERAPY SHOPPE
4	456297		\$1,133.88	Dec 1, 2017	00826	1	TIERNEY BROTHERS, INC.
4	456298		\$101.57	Dec 1, 2017	22123	1	TOTAL FILTRATION SERVICES, INC.
4	456299		\$6,021.54	Dec 1, 2017	03802	0	TRIO SUPPLY
4	456300	Unissued	\$0.00	Dec 1, 2017	03802	0	TRIO SUPPLY
4	456301		\$6,033.82	Dec 1, 2017	26380	0	TYLER TECHNOLOGIES INC
4	456302		\$445.27	Dec 1, 2017	01197	1	US FOODS CULINARY EQUIPMENT & SUPPLIES LLC
4	456303		\$1,850.00	Dec 1, 2017	04306	0	W.E. NEAL SLATE CO.
4	456304		\$300.94	Dec 1, 2017	04419	0	WESTERN PSYCHOLOGICAL SERVICES
4	456306		\$54.00	Dec 2, 2017	04895	0	ASSOCIATION OF CLERICAL EMPLOYEES
4	456307		\$1,985.50	Dec 2, 2017	09991	0	BURNSVILLE ASSOCIATION OF EDUCATIONAL ASSTS
4	456308		\$142.50	Dec 2, 2017	29653	0	CAMPBELL, SUSAN
4	456309		\$13,942.42	Dec 2, 2017	02519	0	CENTERPOINT ENERGY
4	456310		\$438.00	Dec 2, 2017	08621	1	CHILDREN'S THEATRE COMPANY
4	456311		\$60.00	Dec 2, 2017	25919	0	CORDOVA, LETICIA

53

## Check Register Report

Bank Number	Check Number	Check Status	Check Amount	Check Date	Vendor Number	Vendor Address Number	Vendor Name
4	456312		\$131.00	Dec 2, 2017	28531	0	EDUCATION MINNESOTA
4	456313		\$121.00	Dec 2, 2017	27604	0	GREAT LAKES HIGHER EDUCATION CORPORATION
4	456314		\$870.00	Dec 2, 2017	27985	0	HILDI INC.
4	456315		\$24,802.29	Dec 2, 2017	20347	1	HOUSE OF PRINT
4	456316		\$51,532.30	Dec 2, 2017	27633	0	KELLY SERVICES, INC.
4	456317		\$3,759.50	Dec 2, 2017	08356	1	KENNEDY & GRAVEN, CHARTERED
4	456318		\$10,391.00	Dec 2, 2017	02102	0	KRAUS-ANDERSON INS. AGENCY, INC.
4	456319		\$1,588.00	Dec 2, 2017	03814	0	MINNESOTA COMMUNITY EDUCATION ASSOC (MCEA)
4	456320		\$20.00	Dec 2, 2017	08338	0	MN ASSOC OF SECONDARY SCHOOL PRINCIPAL(MASSP)
4	456321		\$350.00	Dec 2, 2017	02538	0	MN ELEMENTARY SCHOOL PRINCIPALS ASSOC (MESPA)
4	456322		\$1,420.00	Dec 2, 2017	04483	2	MN HIGH SCHOOL QUIZ BOWL, INC (MNHSQB)
4	456323		\$509.00	Dec 2, 2017	26466	0	MN HIGHWAY SAFETY & RESEARCH CENTER
4	456324		\$112.00	Dec 2, 2017	08769	0	NCPERS MINNESOTA
4	456325		\$15.00	Dec 2, 2017	25372	4	NCS PEARSON INC
4	456326		\$78.38	Dec 2, 2017	29651	0	NIELSEN, JEFFREY
4	456327		\$1,000.00	Dec 2, 2017	29650	0	NORTH DAKOTA STATE COLLEGE OF SCIENCE
4	456328		\$300.00	Dec 2, 2017	24879	0	PEREZ, MELISSA M.
4	456329		\$55.00	Dec 2, 2017	24681	0	PROFESSIONAL WIRELESS COMMUNICATIONS
4	456330		\$60.00	Dec 2, 2017	21343	0	RAMACHER, THUY
4	456331		\$600.00	Dec 2, 2017	29654	0	RAUTH, CHIP
4	456332		\$1,416.00	Dec 2, 2017	24469	0	REACH MEDIA NETWORK
4	456333		\$2,522.82	Dec 2, 2017	20099	2	RELIASTAR LIFE INSURANCE COMPANY
4	456334		\$2,675.85	Dec 2, 2017	20099	3	RELIASTAR LIFE INSURANCE COMPANY
4	456335		\$1,387.67	Dec 2, 2017	20099	4	RELIASTAR LIFE INSURANCE COMPANY
4	456336		\$22.50	Dec 2, 2017	28434	0	RUPP, ANDERSON, SQUIRES & WALDSPURGER, P.A.
4	456337		\$174.00	Dec 2,	25562	0	SACHS, ALICE

54

## Check Register Report

Bank Number	Check Number	Check Status	Check Amount	Check Date	Vendor Number	Vendor Address Number	Vendor Name
				2017			
4	456338		\$159.38	Dec 2, 2017	20491	0	SAVAGE, DAWN
4	456339		\$68.24	Dec 2, 2017	03532	2	SCHMITT MUSIC
4	456340		\$317.53	Dec 2, 2017	03196	6	SCHOLASTIC INC.
4	456341		\$8,361.52	Dec 2, 2017	07382	0	SCHOOL SERVICES EMPLOYEES LOCAL 284
4	456342		\$624.00	Dec 2, 2017	03609	0	SCIENCE MUSEUM OF MINN.
4	456343		\$425.00	Dec 2, 2017	29575	0	SKOW, KAREN
4	456344		\$4,650.00	Dec 2, 2017	27742	0	STRATEGIC SOURCE INC
4	456345		\$39,579.81	Dec 2, 2017	24486	0	THE HARTFORD
4	456346		\$114.00	Dec 2, 2017	02813	7	US DEPARTMENT OF EDUCATION
4	456347		\$150.00	Dec 2, 2017	29655	0	WESTERLUND, JAYSON
4	456348		\$13.25	Dec 2, 2017	02776	0	XCEL ENERGY
4	456349		\$6,811.50	Dec 5, 2017	25697	0	120 MATTHYS LLC
4	456350		\$2,500.00	Dec 5, 2017	00778	0	ARMSTRONG, MAUREEN
4	456351		\$26.55	Dec 5, 2017	29409	0	CHERRYDALE FARMS
4	456352		\$100.00	Dec 5, 2017	29462	2	CONQUER NINJA ATHLETICS
4	456353		\$633.51	Dec 5, 2017	09654	0	COSTUME RENTALS
4	456354		\$512.00	Dec 5, 2017	26840	0	DAKOTA PRINTING, INC.
4	456355		\$651.22	Dec 5, 2017	26262	0	EDUCATORS BENEFIT CONSULTANTS, LLC
4	456356		\$1,500.00	Dec 5, 2017	26710	1	FESTIVAL SOUND & LIGHTING
4	456357		\$50.00	Dec 5, 2017	03622	2	GALE/CENGAGE LEARNING
4	456358		\$1,344.00	Dec 5, 2017	29656	0	HOUK, MARY
4	456359		\$6,659.00	Dec 5, 2017	28603	1	HUMANeX VENTURES LLC
4	456360		\$100.00	Dec 5, 2017	01994	0	J&R SCHOOL SUPPLIES, INC.
4	456361		\$48,848.10	Dec 5, 2017	27633	0	KELLY SERVICES, INC.
4	456362		\$2,024.06	Dec 5, 2017	25512	0	MAYER ARTS, INC.

55

## Check Register Report

Bank Number	Check Number	Check Status	Check Amount	Check Date	Vendor Number	Vendor Address Number	Vendor Name
4	456363		\$35.00	Dec 5, 2017	08543	7	MN DEPT OF HEALTH
4	456364		\$288.00	Dec 5, 2017	26466	0	MN HIGHWAY SAFETY & RESEARCH CENTER
4	456365		\$332.06	Dec 5, 2017	04796	1	PRAXAIR DISTRIBUTION INC
4	456366		\$89.42	Dec 5, 2017	24681	0	PROFESSIONAL WIRELESS COMMUNICATIONS
4	456367		\$9,000.00	Dec 5, 2017	26796	0	SAFEWAY DRIVING SCHOOL
4	456368		\$177.00	Dec 5, 2017	03532	2	SCHMITT MUSIC
4	456369		\$137.00	Dec 5, 2017	26552	3	SCHOOL NUTRITION ASSOCIATION
4	456370		\$1,060.00	Dec 5, 2017	21607	0	SUCCESS BEYOND THE CLASSROOM
4	456371		\$29,572.37	Dec 5, 2017	29345	1	T-MOBILE
4	456372		\$825.75	Dec 5, 2017	28502	0	THE MCDOWELL AGENCY, INC.
4	456373		\$55,289.79	Dec 5, 2017	04417	1	US FOODS INC
4	456374	Unissued	\$0.00	Dec 5, 2017	04417	1	US FOODS INC
4	456375	Unissued	\$0.00	Dec 5, 2017	04417	1	US FOODS INC
4	456376	Unissued	\$0.00	Dec 5, 2017	04417	1	US FOODS INC
4	456377	Unissued	\$0.00	Dec 5, 2017	04417	1	US FOODS INC
4	456378		\$468.00	Dec 5, 2017	28298	0	US HEALTH WORKS MEDICAL GRP MN, PC
4	456379		\$11,378.45	Dec 8, 2017	28551	0	ADVANCED IMAGING SOLUTIONS
4	456380		\$20,129.70	Dec 8, 2017	28551	1	ADVANCED IMAGING SOLUTIONS
4	456381		\$2,185.48	Dec 8, 2017	09987	1	BEARCOM
4	456382		\$2,040.00	Dec 8, 2017	01737	0	BLAZETTE BOOSTER CLUB
4	456383		\$70.00	Dec 8, 2017	29662	0	BREWSTER, PEYTON
4	456384		\$8,260.99	Dec 8, 2017	02422	5	BURNSVILLE YMCA
4	456385		\$13,576.49	Dec 8, 2017	04226	0	BURNSVILLE, CITY OF
4	456386	Unissued	\$0.00	Dec 8, 2017	04226	0	BURNSVILLE, CITY OF
4	456387		\$266.02	Dec 8, 2017	02781	5	CENTURYLINK
4	456388		\$60.00	Dec 8,	28401	0	CHOY, KEREN

56

## Check Register Report

Bank Number	Check Number	Check Status	Check Amount	Check Date	Vendor Number	Vendor Address Number	Vendor Name
				2017			
4	456389		\$436.20	Dec 8, 2017	27279	1	COLE PAPERS INC.
4	456390		\$14.43	Dec 8, 2017	00016	3341	CURTIS, ANGELIQUE
4	456391		\$949.00	Dec 8, 2017	27788	0	DECA, INC.
4	456392		\$201.94	Dec 8, 2017	22970	0	DELEGARD TOOL COMPANY
4	456393		\$460.00	Dec 8, 2017	20524	0	DEWALD, RINA C.
4	456394		\$70.00	Dec 8, 2017	29661	0	DUNCAN, MACKENZIE
4	456395		\$3,429.46	Dec 8, 2017	01002	0	EAGAN, CITY OF
4	456396		\$178.22	Dec 8, 2017	09272	2	ECM PUBLISHERS, INC.
4	456397		\$70.00	Dec 8, 2017	29660	0	FISCHER, MATTHEW
4	456398		\$2,002.45	Dec 8, 2017	28651	0	FOOD GROUP
4	456399		\$630.00	Dec 8, 2017	01038	0	HEALTH CONSULTANTS FOR CHILD CARE
4	456400		\$3,584.25	Dec 8, 2017	26668	1	HM RECEIVABLES CO LLC
4	456401		\$2,438.95	Dec 8, 2017	20347	1	HOUSE OF PRINT
4	456402		\$1,000.00	Dec 8, 2017	29590	0	HUSAK, PATRICE
4	456403		\$407.22	Dec 8, 2017	25195	0	IPROMOTEU, INC.
4	456404		\$144.00	Dec 8, 2017	29479	0	JAMERSON, FELICIA
4	456405		\$70.00	Dec 8, 2017	29659	0	JASPERSE, JUSTIN
4	456406		\$70.00	Dec 8, 2017	29657	0	MARTIN, EMMA
4	456407		\$170.00	Dec 8, 2017	09951	0	MATH MASTERS OF MN
4	456408		\$450.00	Dec 8, 2017	29658	0	MCDONALD, PAMELA
4	456409		\$959.50	Dec 8, 2017	24921	0	MECA SPORTSWEAR
4	456410		\$220.00	Dec 8, 2017	03814	0	MINNESOTA COMMUNITY EDUCATION ASSOC (MCEA)
4	456411		\$13,159.27	Dec 8, 2017	07448	0	MINNESOTA VALLEY ELECTRIC COOPERATIVE
4	456412		\$350.00	Dec 8, 2017	02538	0	MN ELEMENTARY SCHOOL PRINCIPALS ASSOC (MESPA)
4	456413		\$1,915.00	Dec 8, 2017	09621	4	MN PERCUSSION ASSOCIATION

57

## Check Register Report

Bank Number	Check Number	Check Status	Check Amount	Check Date	Vendor Number	Vendor Address Number	Vendor Name
4	456414		\$5,460.40	Dec 8, 2017	04476	0	NATIONAL TREASURE KUNG FU INC
4	456415		\$3,150.00	Dec 8, 2017	02136	0	NORMANDEALE COMMUNITY COLLEGE
4	456416		\$120.00	Dec 8, 2017	24879	0	PEREZ, MELISSA M.
4	456417		\$369.60	Dec 8, 2017	28168	0	ROARK, RICHARD JEFFREY
4	456418		\$4,741.92	Dec 8, 2017	09588	0	SAVAGE, CITY OF
4	456419		\$20.00	Dec 8, 2017	09588	4	SAVAGE, CITY OF
4	456420		\$724.00	Dec 8, 2017	26552	3	SCHOOL NUTRITION ASSOCIATION
4	456421		\$137.54	Dec 8, 2017	27209	0	SOCCERCHILI
4	456422		\$16.00	Dec 8, 2017	00016	3255	STRAUB, LINDA
4	456423		\$93.09	Dec 8, 2017	04060	0	TRANS-MISSISSIPPI BIOLOGICAL SUPPLY
4	456424		\$750.00	Dec 8, 2017	27429	1	TRANSWORLD SYSTEMS, INC.
4	456425		\$50,605.00	Dec 8, 2017	08595	0	UNIVERSITY OF MINNESOTA-TUITION
4	456426		\$1,102.96	Dec 8, 2017	04417	1	US FOODS INC
4	456427		\$699.00	Dec 12, 2017	00249	1	APPLE COMPUTER INC.
4	456428		\$36.50	Dec 12, 2017	00001	1768	BECKMAN, JAIME
4	456429		\$3,306.84	Dec 12, 2017	03544	2	BEST BUY BUSINESS ADVANTAGE ACCOUNT
4	456430		\$510.00	Dec 12, 2017	29243	0	CARLSON, GERRI
4	456431		\$240.00	Dec 12, 2017	28260	0	CHOY, SERGIO R.
4	456432		\$751.95	Dec 12, 2017	00502	0	CORNERSTONE COPY CENTER
4	456433		\$360.00	Dec 12, 2017	20524	0	DEWALD, RINA C.
4	456434		\$5,112.00	Dec 12, 2017	27788	3	DISTRICT 2 DECA
4	456435		\$99.42	Dec 12, 2017	27334	0	DS ERICKSON
4	456436		\$522,907.49	Dec 12, 2017	28300	1	DURHAM SCHOOL SERVICES
4	456437		\$2,735.27	Dec 12, 2017	02333	1	EARTHGRAINS BAKING CO. INC.
4	456438		\$453.20	Dec 12, 2017	26262	0	EDUCATORS BENEFIT CONSULTANTS, LLC
4	456439		\$105.32	Dec 12,	28202	0	FOUNDATION 191

58

## Check Register Report

Bank Number	Check Number	Check Status	Check Amount	Check Date	Vendor Number	Vendor Address Number	Vendor Name
				2017			
4	456440		\$70.00	Dec 12, 2017	20540	0	INTELLIGERE, INC
4	456441		\$60.00	Dec 12, 2017	24542	0	JAMA, SAFIYO
4	456442		\$152.58	Dec 12, 2017	03519	0	NAPA AUTO PARTS
4	456443		\$1,020.00	Dec 12, 2017	24879	0	PEREZ, MELISSA M.
4	456444	Unissued	\$0.00	Dec 12, 2017	24879	0	PEREZ, MELISSA M.
4	456445		\$60.00	Dec 12, 2017	21343	0	RAMACHER, THUY
4	456446		\$27.80	Dec 12, 2017	03532	2	SCHMITT MUSIC
4	456447		\$125,243.78	Dec 12, 2017	09331	0	SCHMITTY & SONS SCHOOL BUSES, INC.
4	456448		\$85,087.21	Dec 12, 2017	23848	0	SFM
4	456449		\$365.94	Dec 12, 2017	24465	2	SHRED-IT USA
4	456450		\$255.00	Dec 12, 2017	29575	0	SKOW, KAREN
4	456451		\$114,617.09	Dec 12, 2017	08203	1	TIES
4	456452		\$55,835.32	Dec 12, 2017	04417	1	US FOODS INC
4	456453	Unissued	\$0.00	Dec 12, 2017	04417	1	US FOODS INC
4	456454	Unissued	\$0.00	Dec 12, 2017	04417	1	US FOODS INC
4	456455		\$1,066.10	Dec 16, 2017	28491	0	A.J. MOORE ELECTRIC, INC.
4	456456		\$423.50	Dec 16, 2017	01118	0	ABLENET, INC.
4	456457		\$255.25	Dec 16, 2017	29434	0	ACER SERVICE CORPORATION
4	456458		\$9,609.39	Dec 16, 2017	28147	1	AGROPUR INC. DIVISION NATREL USA
4	456459	Unissued	\$0.00	Dec 16, 2017	28147	1	AGROPUR INC. DIVISION NATREL USA
4	456460	Unissued	\$0.00	Dec 16, 2017	28147	1	AGROPUR INC. DIVISION NATREL USA
4	456461	Unissued	\$0.00	Dec 16, 2017	28147	1	AGROPUR INC. DIVISION NATREL USA
4	456462	Unissued	\$0.00	Dec 16, 2017	28147	1	AGROPUR INC. DIVISION NATREL USA
4	456463	Unissued	\$0.00	Dec 16, 2017	28147	1	AGROPUR INC. DIVISION NATREL USA
4	456464	Unissued	\$0.00	Dec 16, 2017	28147	1	AGROPUR INC. DIVISION NATREL USA

59

## Check Register Report

Bank Number	Check Number	Check Status	Check Amount	Check Date	Vendor Number	Vendor Address Number	Vendor Name
4	456465		\$99.54	Dec 16, 2017	01365	0	AMERIPRIDE LINEN AND APPAREL SERVICES
4	456466		\$72.99	Dec 16, 2017	00428	0	ARAMARK
4	456467		\$1,848.36	Dec 16, 2017	26500	0	ARMSTRONG TORSETH SKOLD & RYDEEN INC.
4	456468		\$810.00	Dec 16, 2017	25449	2	AUTOMATED LOGIC CONTRACTING SERVICES
4	456469		\$167.86	Dec 16, 2017	00386	1	BARNES & NOBLE, INC.
4	456470		\$119,172.75	Dec 16, 2017	00459	0	BITUMINOUS ROADWAYS, INC.
4	456471		\$12,843.03	Dec 16, 2017	00477	0	BIX PRODUCE COMPANY
4	456472	Unissued	\$0.00	Dec 16, 2017	00477	0	BIX PRODUCE COMPANY
4	456473	Unissued	\$0.00	Dec 16, 2017	00477	0	BIX PRODUCE COMPANY
4	456474	Unissued	\$0.00	Dec 16, 2017	00477	0	BIX PRODUCE COMPANY
4	456475	Unissued	\$0.00	Dec 16, 2017	00477	0	BIX PRODUCE COMPANY
4	456476		\$3,211.60	Dec 16, 2017	26720	0	BLUE BELL ENTERPRISES, INC.
4	456477		\$4,598.17	Dec 16, 2017	29306	0	C.G.T. LIMITED
4	456478		\$3,775.00	Dec 16, 2017	20289	1	CDW GOVERNMENT, INC.
4	456479		\$12,794.00	Dec 16, 2017	24466	1	CENTER FOR THE COLLABORATIVE CLASSROOM
4	456480		\$11,059.75	Dec 16, 2017	23509	0	COOL AIR MECHANICAL, INC.
4	456481		\$93.93	Dec 16, 2017	00645	0	CUB FOODS
4	456482		\$9,761.95	Dec 16, 2017	04186	1	DALCO
4	456483	Unissued	\$0.00	Dec 16, 2017	04186	1	DALCO
4	456484		\$324.30	Dec 16, 2017	29652	0	DAYLIGHT DESIGNS, INC.
4	456485		\$175.37	Dec 16, 2017	00837	1	DEMCO, INC.
4	456486		\$7,272.07	Dec 16, 2017	00279	0	DIVERSIFIED SNACK DISTRIBUTION
4	456487	Unissued	\$0.00	Dec 16, 2017	00279	0	DIVERSIFIED SNACK DISTRIBUTION
4	456488		\$119.40	Dec 16, 2017	28982	0	EKON-O-PAC, LLC
4	456489		\$929.05	Dec 16, 2017	01078	0	ELECTRO WATCHMAN, INC.
4	456490		\$152.90	Dec 16,	01237	0	ENABLING DEVICES TOYS FOR SPECIAL

69

## Check Register Report

Bank Number	Check Number	Check Status	Check Amount	Check Date	Vendor Number	Vendor Address Number	Vendor Name
				2017			CHILDREN
4	456491		\$42.16	Dec 16, 2017	23054	1	FASTENAL
4	456492		\$210.00	Dec 16, 2017	01541	1	GENERAL PARTS, LLC
4	456493		\$591.66	Dec 16, 2017	01458	1	GOPHER
4	456494		\$1,175.34	Dec 16, 2017	04387	1	GRAINGER
4	456495	Unissued	\$0.00	Dec 16, 2017	04387	1	GRAINGER
4	456496		\$1,155.00	Dec 16, 2017	00575	0	GROTH MUSIC COMPANY
4	456497		\$2,369.93	Dec 16, 2017	07139	0	HASTINGS BUS COMPANY
4	456498		\$956.07	Dec 16, 2017	09046	0	HI TECH REFRIGERATION, INC
4	456499		\$478.45	Dec 16, 2017	09318	1	HILLYARD INC - MINNEAPOLIS
4	456500		\$2,450.00	Dec 16, 2017	26668	1	HM RECEIVABLES CO LLC
4	456501		\$59.97	Dec 16, 2017	04818	0	HORIZON COMMERCIAL POOL SUPPLY
4	456502		\$1,501.25	Dec 16, 2017	27693	0	IDEAL SERVICES, INC.
4	456503		\$1,338.75	Dec 16, 2017	25612	0	IMAGE MARKET
4	456504		\$492.00	Dec 16, 2017	05816	0	JOHN A. DAL SIN & SON, INC.
4	456505		\$15,453.00	Dec 16, 2017	28688	0	K12 TRANSPORTATION MANAGEMENT SERVICES, INC.
4	456506		\$527.25	Dec 16, 2017	08955	0	KELLEHER, HELMRICH AND ASSOCIATES
4	456507		\$146.54	Dec 16, 2017	06419	1	LENSCRAFTERS, INC.
4	456508		\$326.67	Dec 16, 2017	01969	0	LIBRARY STORE, INC.
4	456509		\$21,269.68	Dec 16, 2017	02196	0	MACKIN EDUCATIONAL RESOURCES
4	456510		\$10,209.15	Dec 16, 2017	28793	1	MANSFIELD OIL COMPANY
4	456511		\$2,986.00	Dec 16, 2017	02822	0	MIDWEST FENCE & MFG.
4	456512		\$2,008.80	Dec 16, 2017	08999	1	MINNESOTA ELEVATOR INC
4	456513		\$2,474.75	Dec 16, 2017	02544	1	MTI DISTRIBUTING CO.
4	456514		\$140.88	Dec 16, 2017	02704	0	NASCO
4	456515		\$237.50	Dec 16, 2017	28995	0	NORTH RIDGE COMMUNICATIONS, LLC

61

## Check Register Report

Bank Number	Check Number	Check Status	Check Amount	Check Date	Vendor Number	Vendor Address Number	Vendor Name
4	456516		\$1,114.51	Dec 16, 2017	20320	0	NORTHERN AIR CORPORATION (NAC)
4	456517		\$9.95	Dec 16, 2017	02489	1	OFFICE DEPOT COMPANY
4	456518		\$1,301.00	Dec 16, 2017	26086	0	ORKIN COMMERCIAL SERVICES
4	456519		\$265.31	Dec 16, 2017	03123	0	PAPCO INC
4	456520		\$3,825.00	Dec 16, 2017	29549	0	PIONEER POWER, INC.
4	456521		\$449.64	Dec 16, 2017	28785	0	PRODOCON, INC
4	456522		\$1,980.00	Dec 16, 2017	28785	1	PRODOCON, INC
4	456523		\$240.78	Dec 16, 2017	21851	1	RED WING SHOE COMPANY INC
4	456524		\$9,100.00	Dec 16, 2017	23241	0	RYAN MECHANICAL, INC.
4	456525		\$3,595.00	Dec 16, 2017	24415	1	STRATEGIC EQUIPMENT LLC
4	456526		\$1,437.50	Dec 16, 2017	23998	2	SUMMIT COMMERCIAL FACILITIES GROUP
4	456527		\$8,961.42	Dec 16, 2017	03802	0	TRIO SUPPLY
4	456528	Unissued	\$0.00	Dec 16, 2017	03802	0	TRIO SUPPLY
4	456529		\$234.90	Dec 16, 2017	01197	1	US FOODS CULINARY EQUIPMENT & SUPPLIES LLC
4	456530		\$207.37	Dec 16, 2017	04563	0	WENZEL PLUMBING-HEATING-COOLING LLC
4	456531		\$12,155.69	Dec 14, 2017	28551	0	ADVANCED IMAGING SOLUTIONS
4	456532		\$163.91	Dec 14, 2017	00017	0	AIM ELECTRONICS, INC.
4	456533		\$673.00	Dec 14, 2017	27586	0	AMERICAN OFFICE PRODUCTS
4	456534		\$1,189.56	Dec 14, 2017	01365	0	AMERIPRIDE LINEN AND APPAREL SERVICES
4	456535		\$130.00	Dec 14, 2017	28689	0	ARRIGONI, BRIAN
4	456536		\$600.00	Dec 14, 2017	07257	0	AUTISM SOCIETY OF MN (AUSM)
4	456537		\$524.58	Dec 14, 2017	00386	1	BARNES & NOBLE, INC.
4	456538		\$105.00	Dec 14, 2017	00000	7351	BATI, AMBO
4	456539		\$84.00	Dec 14, 2017	24943	0	BERGERON, JASON
4	456540		\$76.00	Dec 14, 2017	20522	0	BLOCK, DAN
4	456541		\$149.00	Dec 14,	01944	0	BOCHE, JOHN

62

## Check Register Report

Bank Number	Check Number	Check Status	Check Amount	Check Date	Vendor Number	Vendor Address Number	Vendor Name
				2017			
4	456542		\$76.00	Dec 14, 2017	27066	0	BRITT, KEVIN
4	456543		\$149.00	Dec 14, 2017	28686	0	BUCHOLZ, ELLIOTT
4	456544		\$118.00	Dec 14, 2017	24393	0	CASTELLANO, FAYE
4	456545		\$1,947.61	Dec 14, 2017	21968	0	CEL PUBLIC RELATIONS, INC.
4	456546		\$290.00	Dec 14, 2017	07014	4	CHASKA DANCE TEAM INVITATIONAL
4	456547		\$60.00	Dec 14, 2017	28260	0	CHOY, SERGIO R.
4	456548		\$3,470.05	Dec 14, 2017	06231	0	CONSOLIDATED COMMUNICATIONS
4	456549		\$130.00	Dec 14, 2017	29666	0	COUNTERS, BENNETT
4	456550		\$76.00	Dec 14, 2017	28696	0	DALLE, MATT
4	456551		\$76.00	Dec 14, 2017	23031	0	DELGADO, MICHEAL
4	456552		\$10,053.89	Dec 14, 2017	00641	0	DICK'S/LAKEVILLE SANITATION, INC.
4	456553		\$6,933.33	Dec 14, 2017	22061	0	DISTRIBUTED WEBSITE CORPORATION
4	456554		\$76.00	Dec 14, 2017	03725	0	DIXON, RALFORD
4	456555		\$131.00	Dec 14, 2017	28531	0	EDUCATION MINNESOTA
4	456556		\$84.00	Dec 14, 2017	03283	0	ELAM, MICHAEL
4	456557		\$197.54	Dec 14, 2017	00889	1	ELSMORE SWIM SHOP
4	456558		\$17,988.75	Dec 14, 2017	28509	0	EMERGENT NETWORKS
4	456559		\$5,666.67	Dec 14, 2017	04416	0	FAIRVIEW
4	456560		\$2,173.10	Dec 14, 2017	28651	0	FOOD GROUP
4	456561		\$15.00	Dec 14, 2017	00000	7352	FULLER, MARY SUE
4	456562		\$82.00	Dec 14, 2017	29054	0	GARRETT, SCOTT
4	456563		\$2,500.00	Dec 14, 2017	29667	0	GOETZ & ECKLAND P.A.
4	456564		\$82.00	Dec 14, 2017	29665	0	GOULSON, DALE
4	456565		\$121.00	Dec 14, 2017	27604	0	GREAT LAKES HIGHER EDUCATION CORPORATION
4	456566		\$75.00	Dec 14, 2017	27443	0	GREGORY, LORIS SOFIA

63

## Check Register Report

Bank Number	Check Number	Check Status	Check Amount	Check Date	Vendor Number	Vendor Address Number	Vendor Name
4	456567		\$76.00	Dec 14, 2017	24168	0	GRIFFITHS, DAN
4	456568		\$668.36	Dec 14, 2017	00575	0	GROTH MUSIC COMPANY
4	456569		\$116.00	Dec 14, 2017	27516	0	HARRIS, JOHN
4	456570		\$82.00	Dec 14, 2017	29058	0	HAWKINS, CLAUDE
4	456571		\$470.00	Dec 14, 2017	22902	0	HENRY, LAWRENCE
4	456572		\$76.00	Dec 14, 2017	26444	0	HOLTZ, TODD
4	456573		\$320.00	Dec 14, 2017	00722	0	IND SCHOOL DIST #271
4	456574		\$116.65	Dec 14, 2017	02483	1	INTEGRA TELECOM
4	456575		\$60.00	Dec 14, 2017	24542	0	JAMA, SAFIYO
4	456576		\$270.00	Dec 14, 2017	28929	0	JOHN'S SEWER AND DRAIN CLEANING, INC.
4	456577		\$164.00	Dec 14, 2017	24067	0	JOHNSON, DENNIS
4	456578		\$49.00	Dec 14, 2017	00000	3046	JOHNSON, JULIE
4	456579		\$164.00	Dec 14, 2017	08815	0	JOHNSTON, ADAM
4	456580		\$76.00	Dec 14, 2017	29664	0	KASS, TOBEY
4	456581		\$82.00	Dec 14, 2017	06519	0	KORBA, JERRY
4	456582		\$200.00	Dec 14, 2017	02673	4	LAKEVILLE SOUTH HIGH SCHOOL
4	456583		\$2,590.50	Dec 14, 2017	24921	0	MECA SPORTSWEAR
4	456584		\$97.00	Dec 14, 2017	22385	0	METRO TRANSIT
4	456585		\$7,169.41	Dec 14, 2017	03029	1	MINNESOTA ENERGY RESOURCES
4	456586		\$320.00	Dec 14, 2017	22324	0	MULTILINGUAL WORD, INC.
4	456587		\$225.00	Dec 14, 2017	28396	0	NORTH STAR CIRCUIT, INC
4	456588		\$100.00	Dec 14, 2017	02400	1	ORNDORF, RICK
4	456589		\$60.00	Dec 14, 2017	24879	0	PEREZ, MELISSA M.
4	456590		\$240.00	Dec 14, 2017	24358	0	PROCEED
4	456591		\$76.00	Dec 14, 2017	08083	0	RAHJA, MARK
4	456592		\$149.00	Dec 14,	29669	0	RASMUSSEN, DUSTYN

64

## Check Register Report

Bank Number	Check Number	Check Status	Check Amount	Check Date	Vendor Number	Vendor Address Number	Vendor Name
				2017			
4	456593		\$19.00	Dec 14, 2017	00000	7350	RYAN, PATRICIA
4	456594		\$229.33	Dec 14, 2017	03532	2	SCHMITT MUSIC
4	456595		\$26.88	Dec 14, 2017	00016	3256	SCHULTE, SARAH
4	456596		\$254.00	Dec 14, 2017	06455	1	SHAKOPEE HIGH SCHOOL
4	456597		\$149.00	Dec 14, 2017	27931	0	SMITH, CLAYTON
4	456598		\$82.00	Dec 14, 2017	29548	0	TOWNZEN, RYAN
4	456599		\$80.00	Dec 14, 2017	29668	0	TWIN CITY SCALE CO.
4	456600		\$114.00	Dec 14, 2017	02813	7	US DEPARTMENT OF EDUCATION
4	456601		\$45.00	Dec 14, 2017	28298	0	US HEALTH WORKS MEDICAL GRP MN, PC
4	456602		\$16,962.72	Dec 14, 2017	02776	0	XCEL ENERGY
4	456603		\$130.00	Dec 14, 2017	28304	0	ZIMMERMAN, FRANK
<b>Check Count</b>	<b>598</b>	<b>Grand Total</b>	<b>\$3,178,121.37</b>				

65

## Check Register Report

Bank Number	Check Number	Check Status	Check Amount	Check Date	Vendor Number	Vendor Address Number	Vendor Name
3	102128		\$589.44	Dec 1, 2017	29445	0	ALLEGRA
3	102129		\$6,755.25	Dec 1, 2017	01078	0	ELECTRO WATCHMAN, INC.
3	102130		\$1,300.00	Dec 1, 2017	26949	0	FAIRFIELD GLASS & WINDOW, INC.
3	102131		\$3,000.00	Dec 1, 2017	27702	0	MORCON CONSTRUCTION INC.
3	102132		\$41,035.60	Dec 1, 2017	20320	1	NORTHERN AIR CORPORATION
3	102133		\$12,425.38	Dec 8, 2017	26500	0	ARMSTRONG TORSETH SKOLD & RYDEEN INC.
3	102134		\$1,219.08	Dec 8, 2017	09987	1	BEARCOM
<b>Check Count</b>	<b>7</b>	<b>Grand Total</b>	<b>\$66,324.75</b>				

66



**Agenda IV.B.5**  
**January 18, 2018**

**TO: Cynthia Amoroso, Superintendent and Board of Education**  
**FROM: Lisa K. Rider, Executive Director of Business Services**  
**DATE: January 25, 2018**  
**RE: Budget Analysis for the Month Ending November 30, 2017**

**RECOMMENDATION:** That the Board accepts the Budget Analysis for the month ending November 30, 2017

The November Budget Reports are presented for Board information and review. The reports indicate the following:

	<u>Year-to-Date Revenue</u>	<u>% of Adopted Budget</u>	<u>Year-to-Date Expenditures</u>	<u>% of Adopted Budget</u>
All Funds	\$ 63,197,024	36.62%	\$ 59,866,783	26.52%
General Fund	\$ 50,405,720	40.06%	\$ 40,577,389	31.07%

To assist the Board in monitoring monthly financial activity and to help identify budget-to-actual deviations, the following graphs have been developed for all funds and the general fund:

Cash and Investments by Month for Last year and Current year  
 Revenues Year-to-Date for Last two years and Current year  
 Expenditures Year-to-Date for Last two years and Current year

All of the reports and graphs show last year's actual figures, this year's budget and this year's activity to day. Additional detail is available upon request.

# ALL FUNDS CASH AND INVESTMENTS 2016-17 AND 2017-18

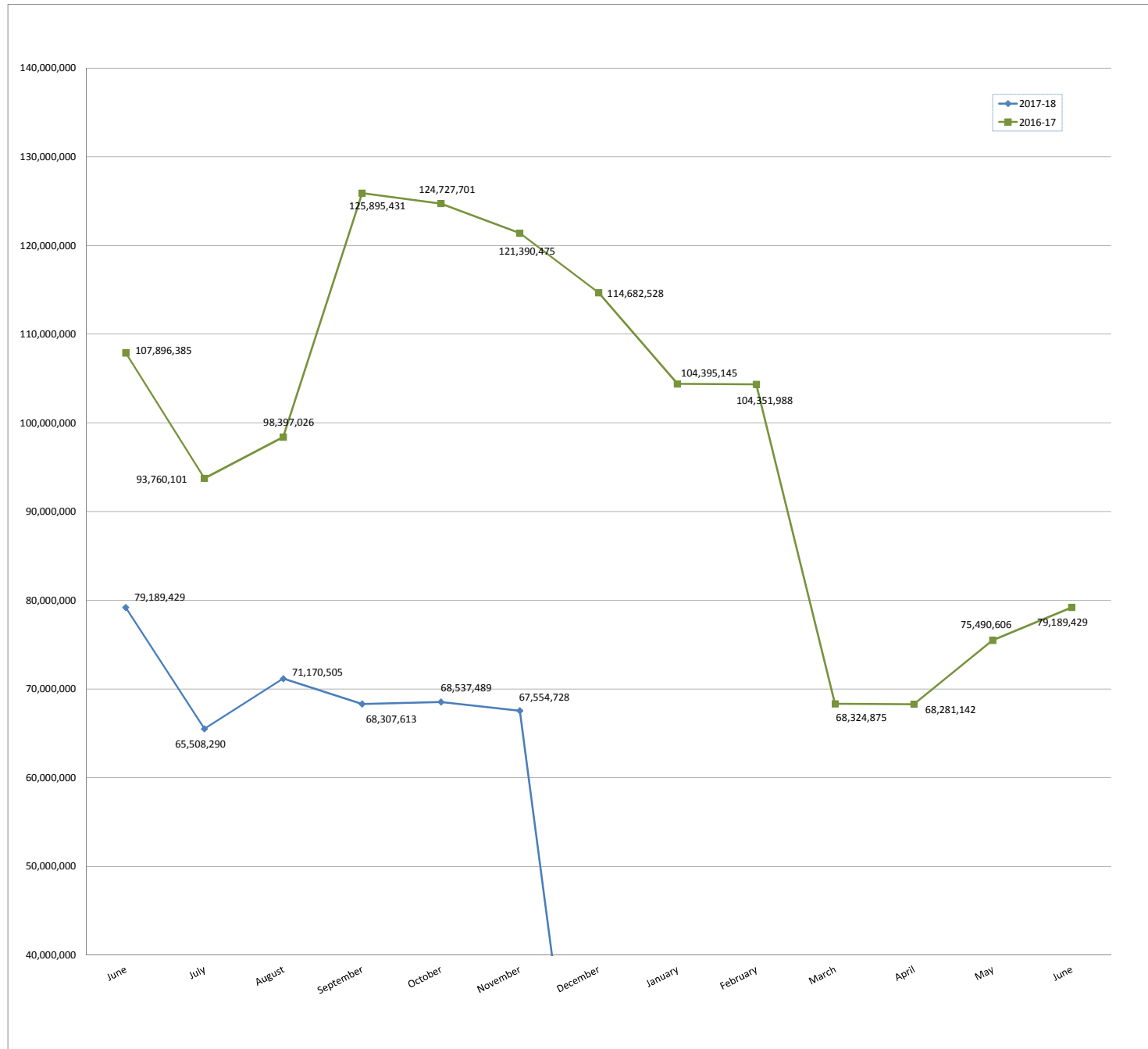

**REVENUE COMPARISON  
ALL FUNDS**

	2015-2016		2016-2017		2017-2018	
	\$	%	\$	%	\$	%
July	3,044,376	1.76%	2,809,302	1.63%	4,408,507	2.55%
August	20,776,436	12.04%	25,542,740	14.80%	23,331,132	13.52%
September	32,729,505	18.96%	35,814,597	20.75%	35,437,865	20.53%
October	41,826,417	24.23%	50,756,340	29.41%	50,946,461	29.52%
November	45,631,362 **	26.44%	61,773,537 **	35.79%	63,197,024 **	36.62%
December	48,389,298	28.04%	62,140,926	36.00%		0.00%
January	62,310,017	36.10%	90,177,955	52.25%		0.00%
February	75,637,174	43.82%	103,945,953	60.23%		0.00%
March	90,285,615	52.31%	119,608,094	69.30%		0.00%
April	104,623,897	60.62%	135,537,967	78.53%		0.00%
May	166,252,241	96.33%	156,805,987	90.85%		0.00%
June	181,117,868	104.94%	190,363,597	110.30%		0.00%
<b>BUDGET</b>	<b>162,577,015</b>	<b>100.00%</b>	<b>185,899,440</b>	<b>100.00%</b>	<b>172,593,648</b>	<b>100.00%</b>

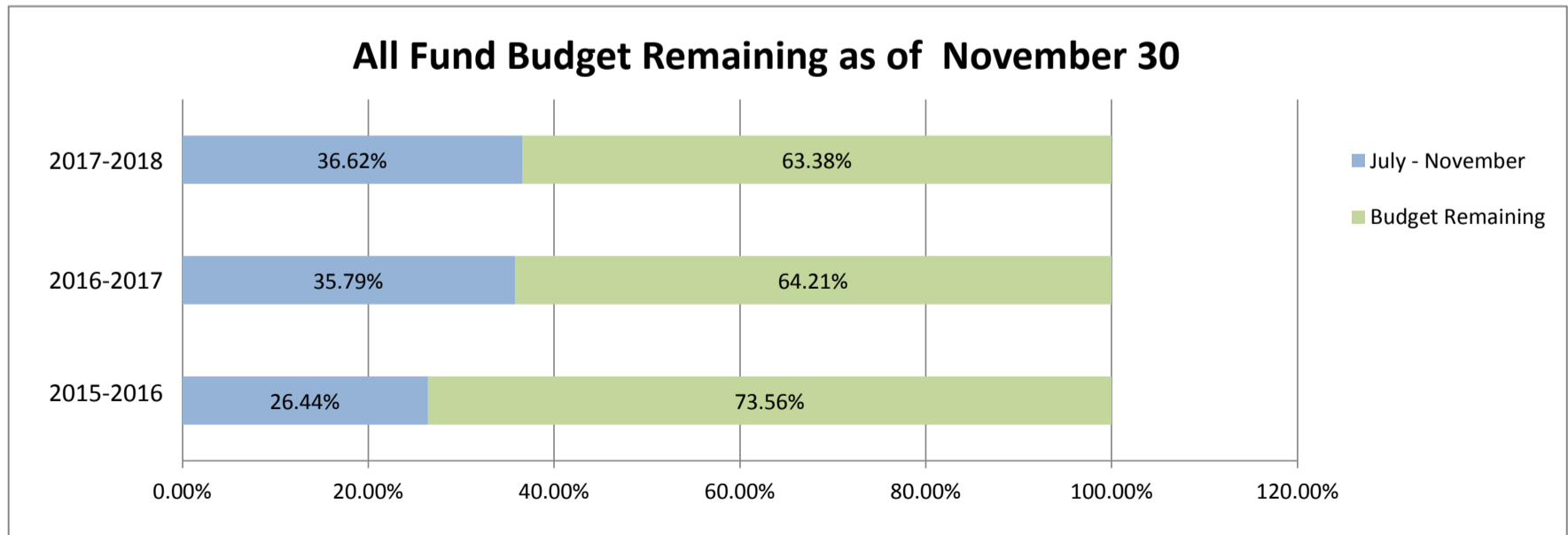
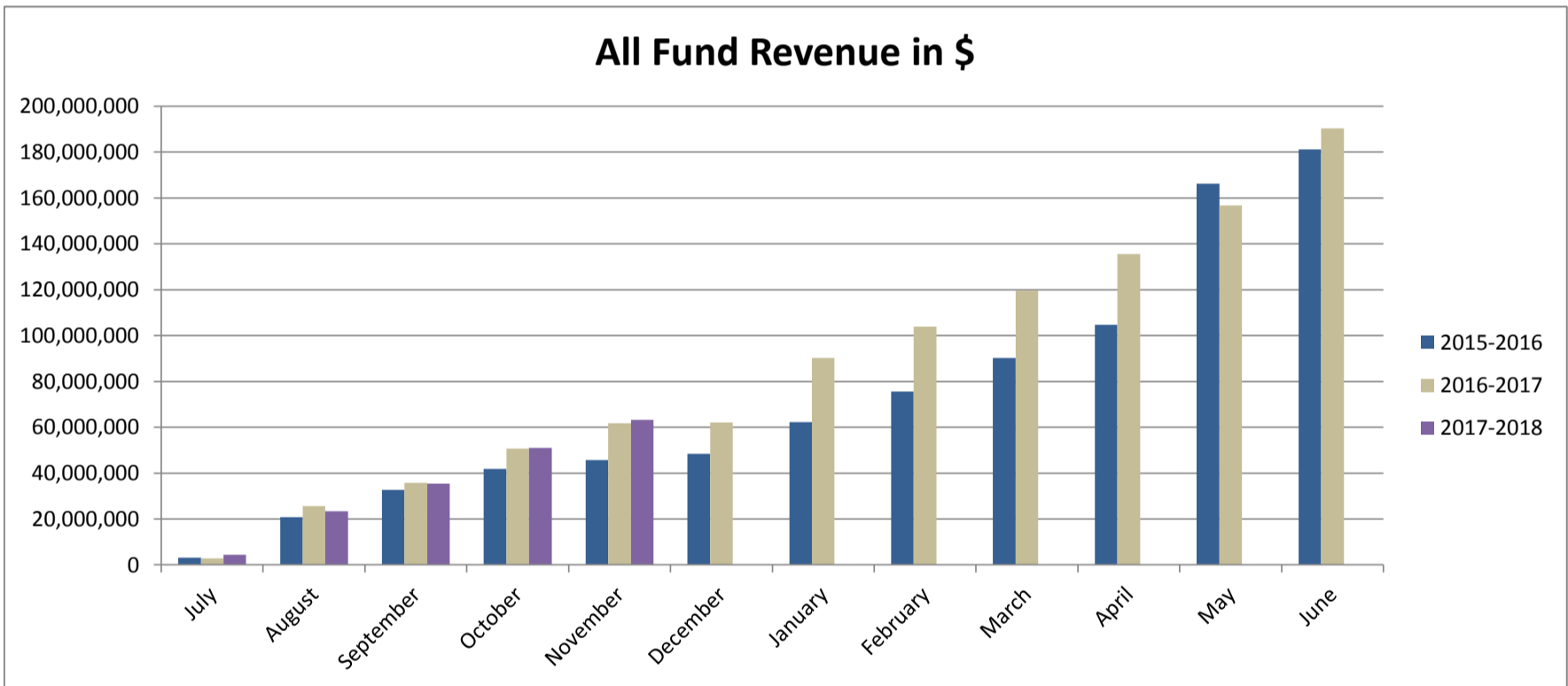

\*\* The year to year comparison will vary due to the timing of the reversal of prior year accruals.

**EXPENDITURE COMPARISON  
ALL FUNDS**

	2015-2016		2016-2017		2017-2018	
	\$	%	\$	%	\$	%
July	7,049,033	3.12%	5,196,342	2.30%	10,085,346	4.47%
August	16,404,117	7.27%	18,514,790	8.20%	18,992,738	8.41%
September	30,882,275	13.68%	39,525,196	17.51%	32,446,236	14.38%
October	44,144,329	19.56%	56,289,453	24.94%	46,483,002	20.59%
November	58,247,227	25.81%	70,699,295	31.32%	59,866,783	26.52%
December	73,968,194	32.77%	88,941,755	39.41%		0.00%
January	97,976,121	43.41%	112,826,815	49.99%		0.00%
February	111,499,625	49.40%	126,370,492	55.99%		0.00%
March	127,360,079	56.43%	149,154,290	66.08%		0.00%
April	142,980,681	63.35%	164,279,619	72.78%		0.00%
May	162,380,604	71.94%	177,853,141	78.80%		0.00%
June	204,018,788	90.39%	211,687,557	93.79%		0.00%
<b>BUDGET</b>	<b>236,752,755</b>	<b>100.00%</b>	<b>209,757,533</b>	<b>100.00%</b>	<b>225,706,752</b>	<b>100.00%</b>

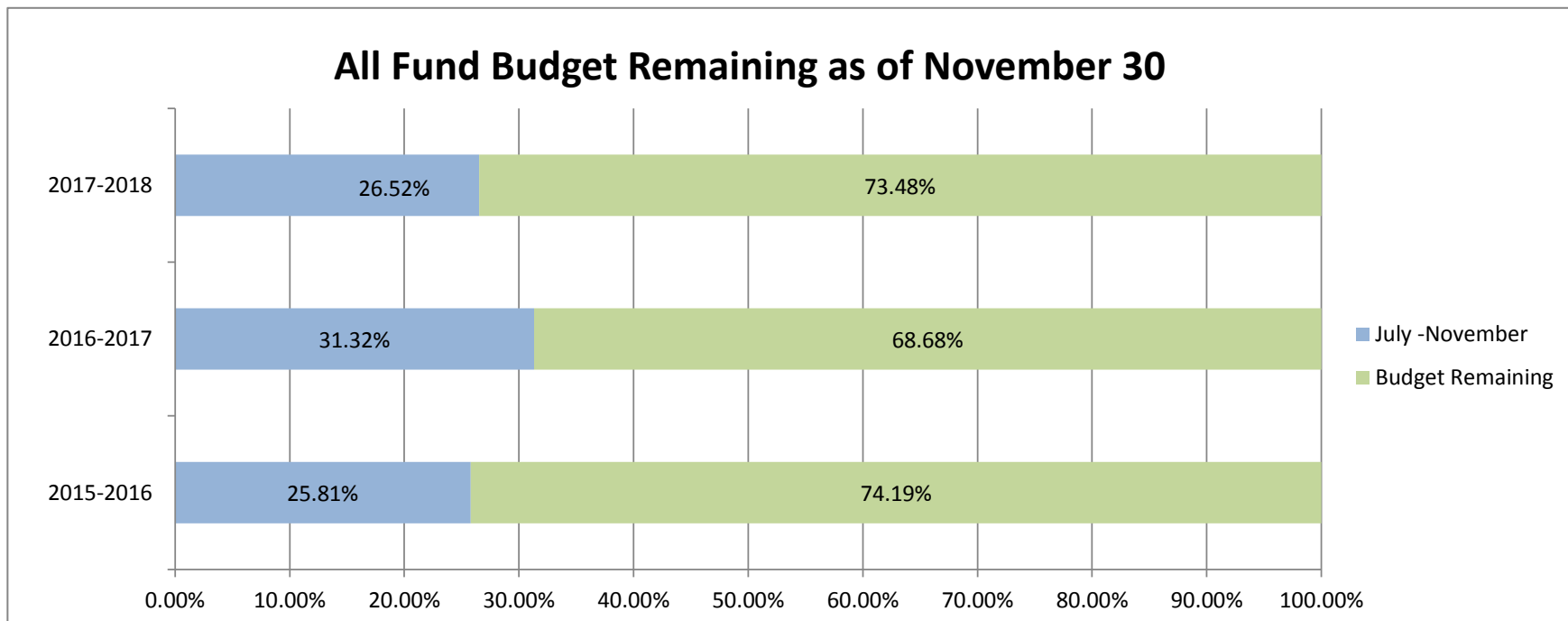
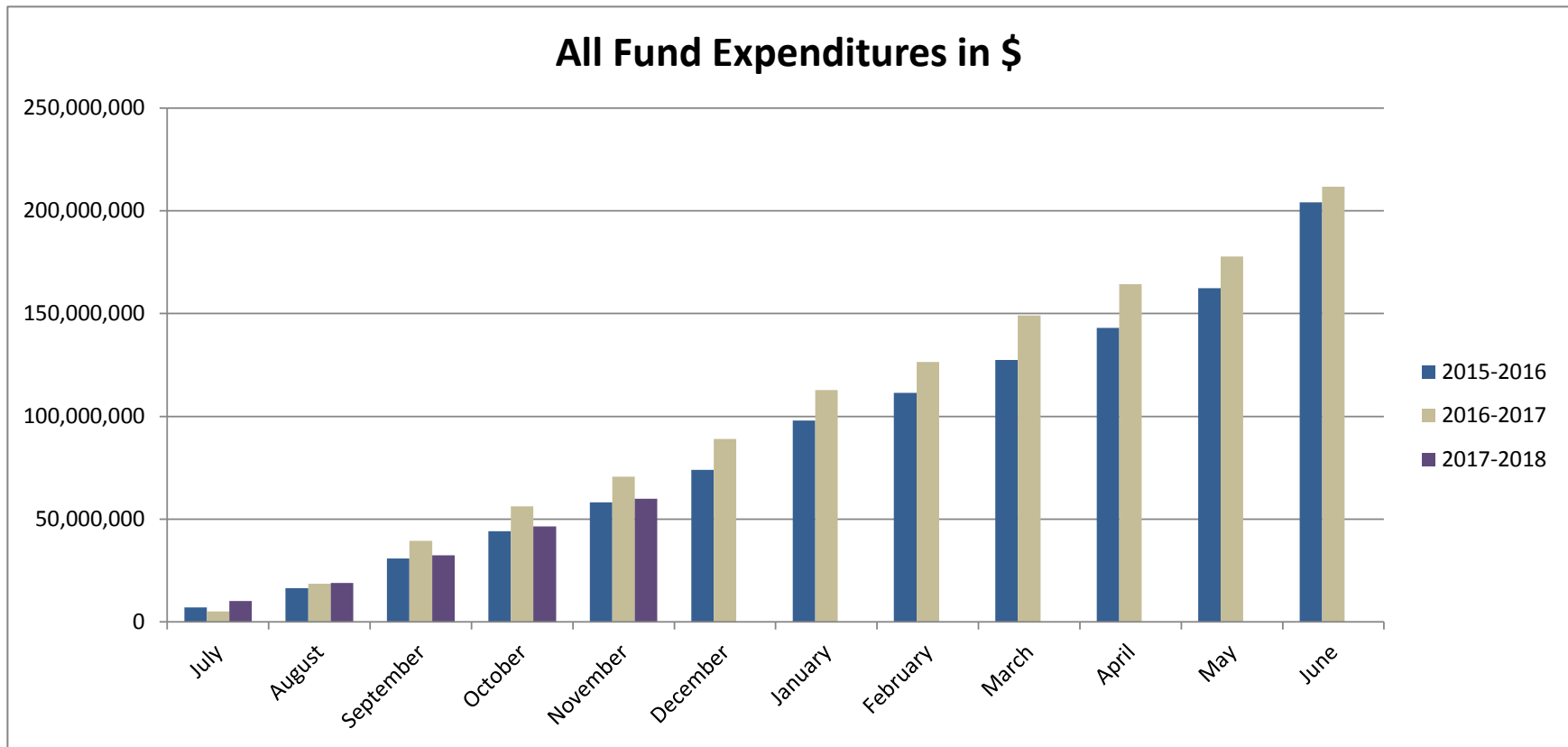

# GENERAL FUND CASH AND INVESTMENTS 2016-17 AND 2017-18

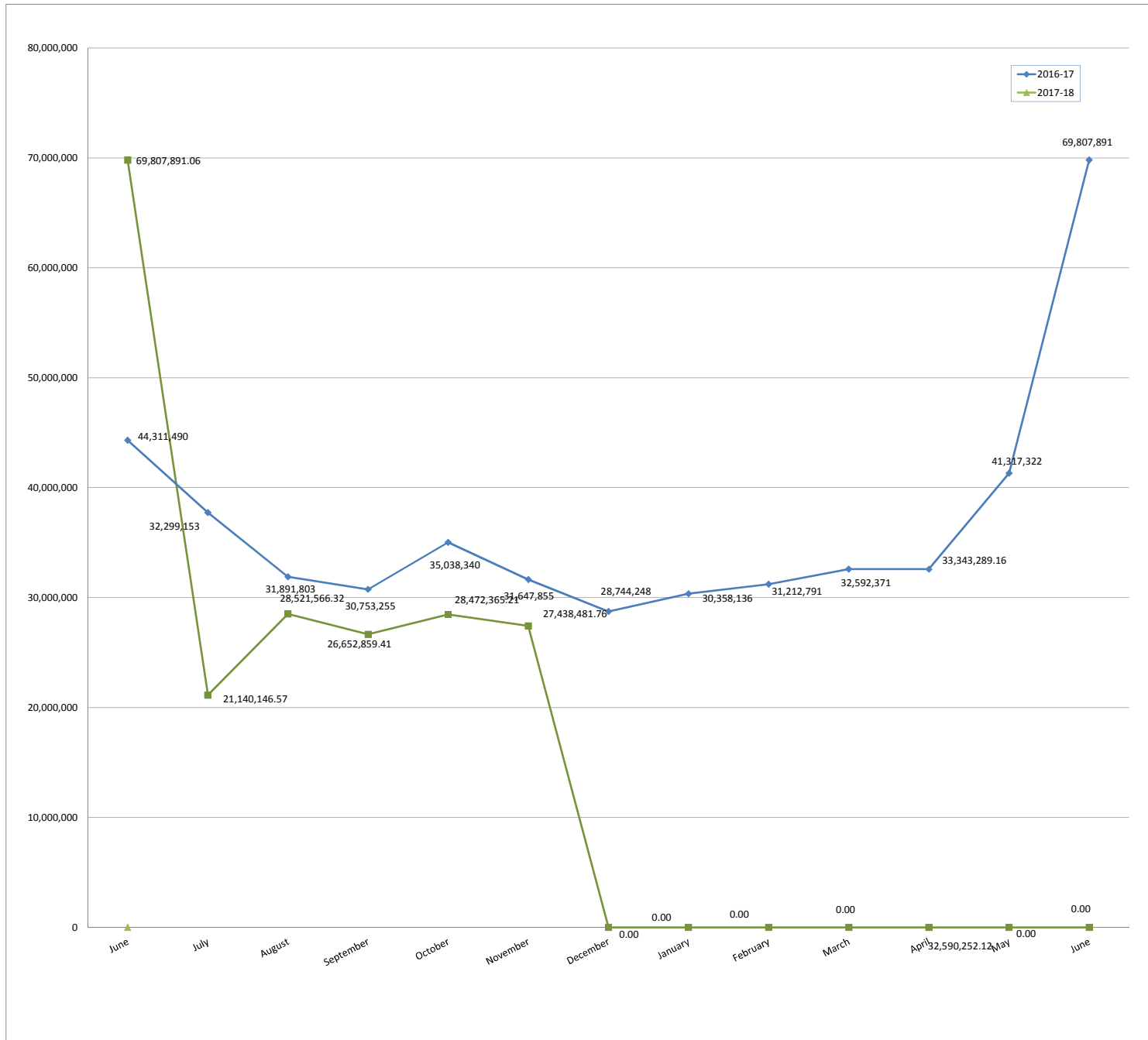

**REVENUE COMPARISON  
GENERAL FUND**

	2015-2016		2016-2017		2017-2018	
	\$	%	\$	%	\$	%
July	1,172,002	0.93%	2,428,394	1.93%	2,439,823	1.94%
August	16,819,666	13.37%	18,330,814	14.57%	19,160,640	15.23%
September	26,303,462	20.90%	27,731,893	22.04%	28,923,752	22.98%
October	32,868,210	26.12%	40,727,980	32.37%	41,294,231	32.81%
November	33,523,977 **	26.64%	49,365,639 **	39.23%	50,405,720 **	40.06%
December	33,750,953	26.82%	46,887,839	37.26%		0.00%
January	44,669,701	35.50%	59,026,452	46.91%		0.00%
February	55,293,029	43.94%	69,731,505	55.41%		0.00%
March	67,001,225	53.24%	81,909,480	65.09%		0.00%
April	78,653,851	62.50%	94,081,747	74.76%		0.00%
May	97,297,732	77.32%	112,774,259	89.62%		0.00%
June	111,032,879	88.23%	127,035,902	100.95%		0.00%
<b>BUDGET</b>	<b>118,046,063</b>	<b>100.00%</b>	<b>125,084,975</b>	<b>100.00%</b>	<b>125,839,549</b>	<b>100.00%</b>

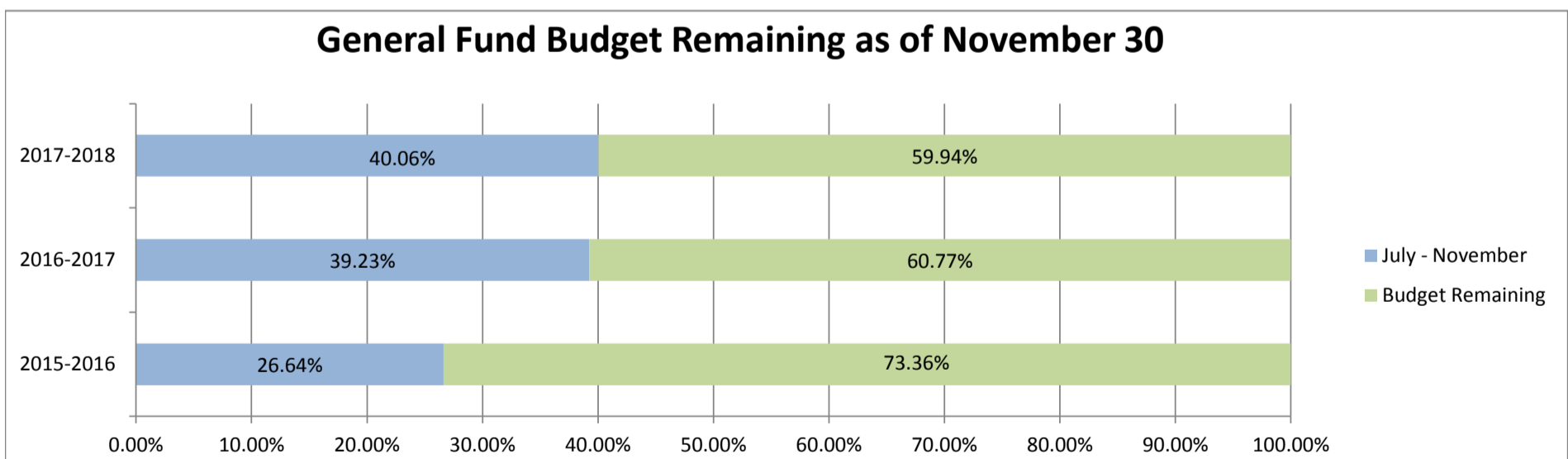
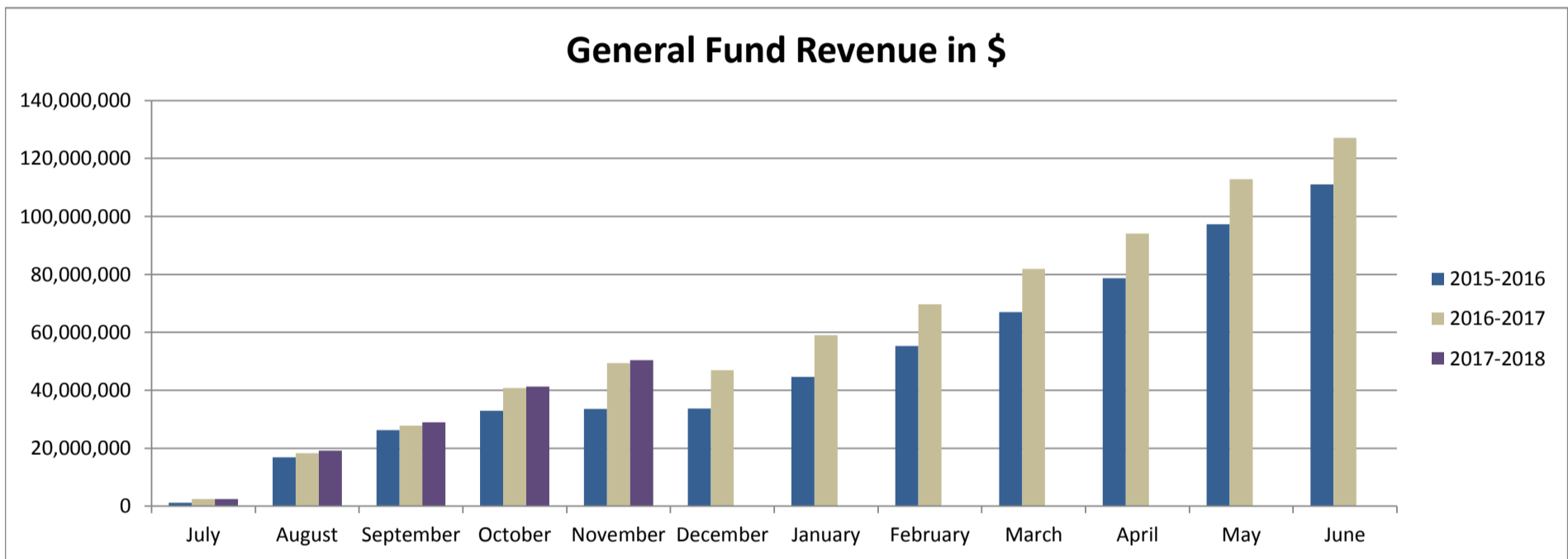

**EXPENDITURE COMPARISON  
GENERAL FUND**

	2015-2016		2016-2017		2017-2018	
	\$	%	\$	%	\$	%
July	2,684,247	2.06%	3,281,485	2.51%	3,704,721	2.84%
August	7,972,377	6.10%	9,904,860	7.58%	10,272,961	7.87%
September	16,911,827	12.95%	19,362,893	14.83%	20,165,861	15.44%
October	25,943,715	19.87%	28,951,109	22.17%	30,322,535	23.22%
November	35,429,463	27.13%	39,179,314	30.00%	40,577,389	31.07%
December	45,930,671	35.17%	50,514,628	38.68%		0.00%
January	55,592,345	42.57%	60,876,065	46.61%		0.00%
February	65,071,177	49.83%	70,609,184	54.07%		0.00%
March	76,193,365	58.34%	81,513,622	62.42%		0.00%
April	85,924,006	65.79%	92,821,959	71.07%		0.00%
May	96,128,215	73.61%	102,373,514	78.39%		0.00%
June	118,503,256	90.74%	129,530,276	99.18%		0.00%
<b>BUDGET</b>	<b>121,227,919</b>	<b>100.00%</b>	<b>126,665,266</b>	<b>100.00%</b>	<b>130,598,185</b>	<b>100.00%</b>

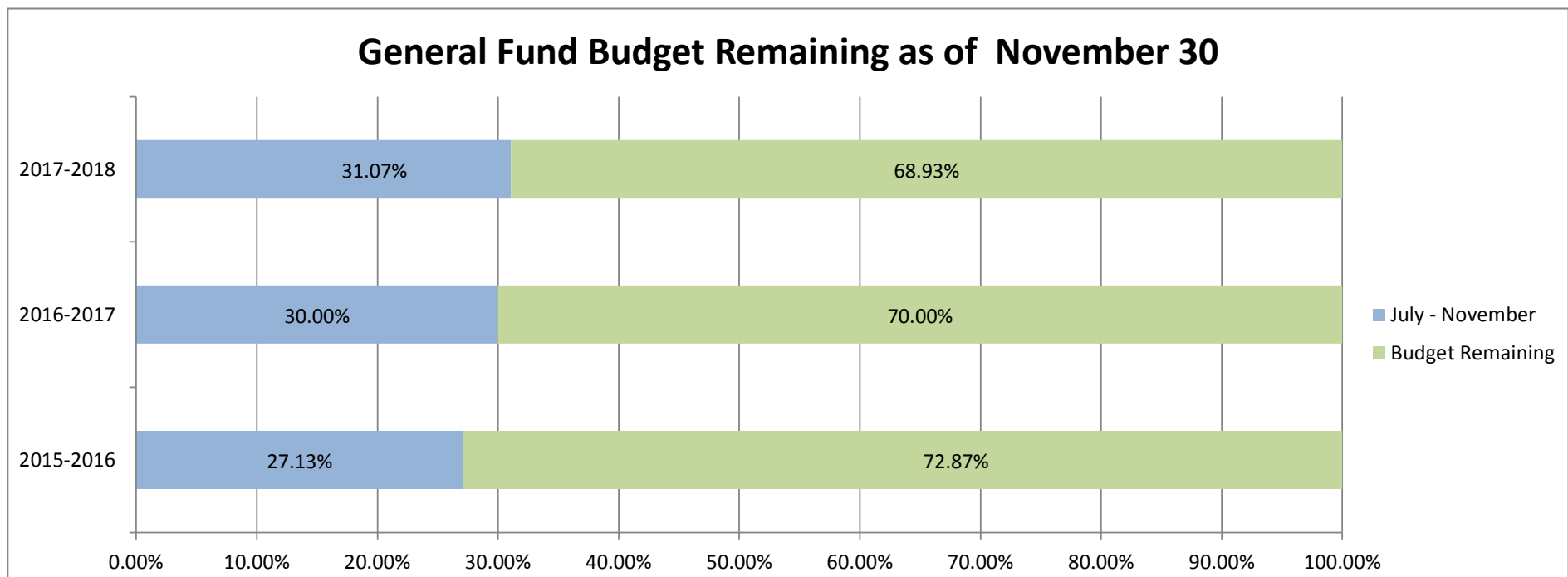
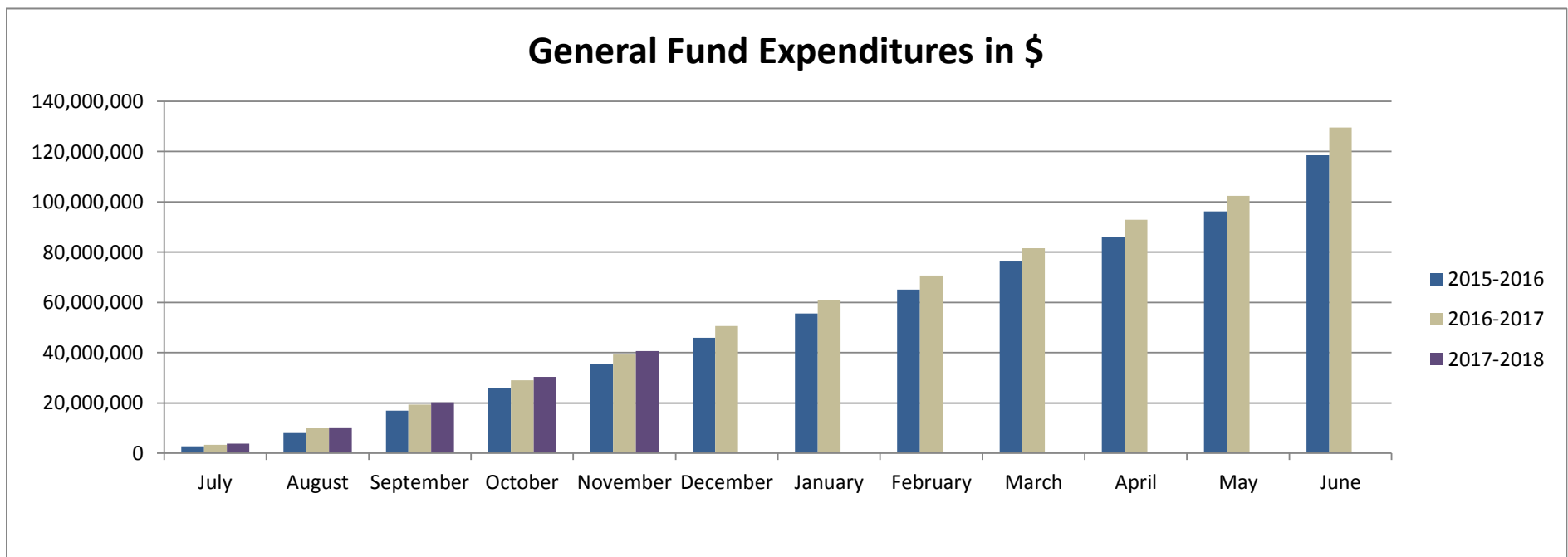



**Agenda IV.A.6.  
January 25, 2018**

**To:** Board of Education, Members  
**From:** Cindy Amoroso, Superintendent  
**Date:** January 18, 2018  
**Re:** Report on Listening Session

Board Members present: Bob VandenBoom and Eric Miller. No one came to speak to the Board on January 11, 2018.



**Future Ready. Community Strong.**

**Agenda IV.A.7.  
January 25, 2018**

**To:** Board of Education  
Cindy Amoroso, Superintendent

**From:** Stacey Sovine, Executive Director of Human Resources, and Dave Watkins,  
Assistant Superintendent

**Date:** January 18, 2018

**Re:** Policies 402: *Disability Nondiscrimination Policy*; 403: *Discipline, Suspension, and Dismissal of School District Employees*; 404: *Employment Background Checks*; 424: *License Status*; 521: *Student Disability Nondiscrimination*; 620: *Credit for Learning*; and 903: *Visitors to School District Buildings and Sites*

**Recommendation:** Approve, on a second reading basis, Policies 402: *Disability Nondiscrimination Policy*; 403: *Discipline, Suspension, and Dismissal of School District Employees*; 404: *Employment Background Checks*; 424: *License Status*; 521: *Student Disability Nondiscrimination*; 620: *Credit for Learning*; and 903: *Visitors to School District Buildings and Sites*.

These policies were reviewed at the Policy Review Committee meeting on December 19, 2017 and the first reading of the policies was approved on January 11, 2018.

- 402: *Disability Nondiscrimination Policy* – Removed “Section 504 coordinator.”
- 403: *Discipline, Suspension, and Dismissal of School District Employees* - the policy has been changed to align with our current practice.
- 404: *Employment Background Checks* – Removed “extracurricular” and “signed informed consent form.” Clarified that a BCA component must be included in the background check.
- 424: *License Status* – Changed “school board” to “school district.”
- 521: *Student Disability Nondiscrimination* - added contact information, removed “ADA coordinator” and reference to form.
- 620: *Credit for Learning*; and 903: *Visitors to School District Buildings and Sites* - the changes were suggested by MSBA and reviewed by administration.

*Adopted:* 05/2001  
*Reviewed:* 1/25/2018  
*Revised:* 1/11/2018  
*Rescinds:*

*Burnsville-Eagan-Savage School District Policy 402*

**402 DISABILITY NONDISCRIMINATION POLICY**

**I. PURPOSE**

The purpose of this policy is to provide a fair employment setting for all persons in Independent School District 191 and to comply with state and federal law.

**II. GENERAL STATEMENT OF POLICY**

- A. Independent School District 191 shall not discriminate against qualified individuals with disabilities because of the disabilities of such individuals in regard to job application procedures, hiring, advancement, discharge, compensation, job training, and other terms, conditions, and privileges of employment.
- B. Independent School District 191 shall not engage in contractual or other arrangements that have the effect of subjecting its qualified applicants or employees with disabilities to discrimination on the basis of disability. Independent School District 191 shall not exclude or otherwise deny equal jobs or job benefits to a qualified individual because of the known disability of an individual with whom the qualified individual is known to have a relationship or association.
- C. Independent School District 191 shall make reasonable accommodations for the known physical or mental limitations of an otherwise qualified individual with a disability who is an applicant or employee, unless the accommodation would impose undue hardship on the operation of the business of the school district.
- D. Any job applicant or employee wishing to discuss the need for a reasonable accommodation, or other matters related to a disability or the enforcement and application of this policy, should contact Stacey Sovine, Executive Director of Human Resources, 200 West Burnsville Parkway, Burnsville, MN, 55337, 952-707-2010, ssovine@isd191.org. This individual is the school district's appointed ADA coordinator.

**Legal References:** Minn. Stat. Ch. 363A (Minnesota Human Rights Act)  
29 U.S.C. 794 *et seq.* (Rehabilitation Act of 1973, § 504)  
42 U.S.C., Ch. 126 § 12112 (Americans with Disabilities Act)  
29 C.F.R. Part 32  
34 C.F.R. Part 104

***Cross References:*** Burnsville-Eagan-Savage School District Policy 521 (Student Disability Nondiscrimination)

*Adopted: 4/1987*  
*Reviewed: 1/11/2018*  
*Revised: 1/25/2018*  
*Rescinds: GCPAB*

## **403 DISCIPLINE, SUSPENSION, AND DISMISSAL OF SCHOOL DISTRICT EMPLOYEES**

### **I. PURPOSE**

The purpose of this policy is to achieve the effective operation of Independent School District 191's programs through the cooperation of all employees under a system of policies and rules applied fairly and uniformly.

### **II. GENERAL STATEMENT OF POLICY**

The disciplinary process described herein is designed to utilize progressive steps, where appropriate, to produce positive corrective action. While the school district intends that in most cases progressive discipline will be administered, the specific form of discipline chosen in a particular case and/or the decision to impose discipline in a manner otherwise, is solely within the discretion of the school district.

### **III. DISCIPLINE**

#### **A. Violation of School Laws and Rules**

The form of discipline imposed for violations of school laws and rules may vary from a written reprimand to termination of employment or discharge depending upon factors such as the nature of the violation, whether the violation was intentional, knowing and/or willful and whether the employee has been the subject of prior disciplinary or corrective action of the same or a different nature. School laws and rules to which this provision applies include:

1. policies of Independent School District 191;
2. directives and/or job requirements imposed by administration and/or the employee's supervisor; and
3. federal, state and local laws, rules and regulations, including, but not limited to, the rules and regulations adopted by federal and state agencies.

#### **B. Substandard Performance**

An employee's substandard performance may result in the imposition of discipline ranging from a written reprimand to termination of employment or discharge. In most instances, discipline imposed for the reason of substandard performance will

follow a progressive format and will be accompanied by guidance, help and encouragement to improve from the employee's supervisor and reasonable time for correction of the employee's deficiency.

C. Misconduct

Misconduct of an employee will result in the imposition of discipline consistent with the seriousness of the misconduct. Conduct which falls into this category includes, but is not limited to:

1. unprofessional conduct;
2. failure to observe rules, regulations, policies and standards of Independent School District 191 and/or directives and orders of supervisors and any other act of an insubordinate nature;
3. continuing neglect of duties in spite of oral warnings, written warnings and/or other forms of discipline;
4. personal and/or immoral misconduct;
5. use of illegal drugs, alcohol or any other chemical substance on the job or any use off the job which impacts on the employee's performance;
6. deliberate and serious violation of the rights and freedoms of other employees, students, parents or other persons in the school community;
7. activities of a criminal nature relating to the fitness or effectiveness of the employee to perform the duties of the position;
8. failure to follow the canons of professional and personal ethics;
9. falsification of credentials and experience;
10. unauthorized destruction of school district property;
11. other good and sufficient grounds relating to any other act constituting inappropriate conduct;
12. neglect of duty;
13. violation of the rights of others as provided by federal and state laws related to human rights.

**IV. FORMS OF DISCIPLINE**

- A. The forms of discipline and corrective action that may be imposed by Independent School District 191 include, but are not limited to verbal or written warning; written

reprimand; disciplinary suspension, demotion or leave of absence without pay; and dismissal/termination or discharge from employment.

- B. Other forms of discipline, including any combination of the forms described in Paragraph A., above, may be imposed if, in the judgment of the administration, another form of discipline will better accomplish Independent School District 191's objective of stopping or correcting the offending conduct and improving the employee's performance.

## V. PROCEDURES FOR ADMINISTERING POLICY

- A. In an instance where any form of discipline is imposed, the employee's supervisor will:
  - 1. Advise the employee of any inadequacy, deficiency or conduct which is the cause of the discipline.
  - 2. Provide directives to the employee to correct the conduct or performance.
  - 3. Forward copies of all writings to the Executive Director of Human Resources for filing in the employee's personnel file.
  - 4. Allow a reasonable period of time, when appropriate, for the employee to correct or remediate the performance or conduct.
  - 5. Specify the expected level of performance or modification of conduct to be required from the employee.
- B. Independent School District 191 retains the right to immediately discipline, terminate or discharge an employee as appropriate, subject to relevant governing law and collective bargaining agreements where applicable.

**Legal References:** Minn. Stat. § 122A.40 (Teachers – Employment; Contracts; Termination)  
Minn. Stat. § 122A.41 (Teacher Tenure)  
Minn. Stat. § 122A.44 (Contracting with Teachers)  
Minn. Stat. § 122A.58 (Coaches)  
Minn. Stat. § 123B.02, Subd. 14 (Employees; Contracts for Services)  
Minn. Stat. § 123B.143 (Superintendent)  
Minn. Stat. § 123B.147 (Principals)  
Minn. Stat. § 197.46 *et seq.* (Veterans Preference Act)

**Cross References:** MSBA Service Manual, Chapter 3, Employees

*Adopted:* 3/2007  
*Reviewed:* 1/11/2018  
*Revised:* 1/25/2018  
*Rescinds:* GCDC

## **404 EMPLOYMENT BACKGROUND CHECKS**

### **I. PURPOSE**

The purpose of this policy is to maintain a safe and healthful environment in the school district in order to promote the physical, social, and psychological well-being of its students. To that end, Independent School District 191 will seek a criminal history background check for applicants who receive an offer of employment with the school district and on all individuals, except enrolled student volunteers, who are offered the opportunity to provide athletic coaching services or other academic coaching services to the school district, regardless of whether any compensation is paid, or such other background checks as provided by this policy. The school district will also conduct criminal history background checks on all adults who provide after and during school academic assistance to students or who volunteer as chaperones for students on school-sponsored, overnight field trips. The school district may also elect to do background checks of other volunteers, independent contractors, and student employees in the school district.

### **II. GENERAL STATEMENT OF POLICY**

- A. The school district shall require that applicants for school district positions who receive an offer of employment and all individuals, except enrolled student volunteers, who are offered the opportunity to provide athletic coaching services or other academic coaching services to the school district, regardless of whether any compensation is paid, submit to a criminal history background check. The offer of employment or the opportunity to provide services shall be conditioned upon a determination by the school district that an individual's criminal history does not preclude the individual from employment with, or provision of services to, the school district.
- B. The school district specifically reserves any and all rights it may have to conduct background checks regarding current employees, applicants, or service providers without the consent of such individuals.
- C. Adherence to this policy by the school district shall in no way limit the school district's right to require additional information, or to use procedures currently in place or other procedures to gain additional background information concerning employees, applicants, volunteers, service providers, independent contractors, and student employees.

### **III. PROCEDURES**

- A. Normally an individual will not commence employment or provide services until the school district receives the results of the criminal history background check. The school district may conditionally hire an applicant or allow an individual to provide services pending completion of the background check, but shall notify the individual that the individual's employment or opportunity to provide services may be terminated based on the result of the background check. Background checks will be performed and must include a Minnesota Bureau of Criminal Apprehension (BCA) component. The agency shall conduct the background check by retrieving criminal history data as defined in Minn. Stat. § 13.87. The school district reserves the right to also have criminal history background checks conducted by other organizations or agencies.
- B. For an individual to be eligible for employment, to provide athletic coaching services or other academic coaching services, volunteer academic assistance, or chaperone services to the school district, except for an enrolled student volunteer, the individual must sign a criminal history consent form, which provides permission for the school district to conduct a criminal history background check, and provide a money order or check payable to either the BCA or to the school district, at the election of the school district, in an amount equal to the actual cost to the BCA and the school district of conducting the criminal history background check. The cost of the criminal history background check is the responsibility of the individual, unless the school district decides to pay the costs for a volunteer, an independent contractor, or a student employee. If the individual fails to complete the background check at the time the individual receives a job offer, or permission to provide services, the individual will be considered to have voluntarily withdrawn the application for employment or request to provide services.
- C. The school district, in its discretion, may elect not to request a criminal history background check on an individual who holds an initial entrance license issued by the state board of teaching or the commissioner of education within the 12 months preceding an offer of employment or permission to provide services.
- D. The school district may use the results of a criminal background check conducted at the request of another school hiring authority if:
1. the results of the criminal background check are on file with the other school hiring authority or otherwise accessible;
  2. the other school hiring authority conducted a criminal background check within the previous 12 months;
  3. the individual executes a written consent form giving the school district access to the results of the check; and
  4. there is no reason to believe that the individual has committed an act subsequent to the check that would disqualify the individual for

employment or provision of services.

- E. For all nonstate residents who are offered employment with or the opportunity to provide athletic coaching services or other academic coaching services to the school district, the school district shall request a criminal history background check on such individuals from the superintendent of the BCA and from the government agency performing the same function in the resident state or, if no government entity performs the same function in the resident state, from the Federal Bureau of Investigation. The offer of employment or the opportunity to provide services shall be conditioned upon a determination by the school district that an individual's criminal history does not preclude the individual from employment with, or provision of services to, the school district. Such individuals must provide an executed criminal history consent form.
- F. When required, individuals must provide fingerprints to assist in a criminal history background check. If the fingerprints provided by the individual are unusable, the individual will be required to submit another set of prints.
- G. Copies of this policy shall be available in the school district's employment office and will be distributed to applicants for employment and individuals who are offered the opportunity to provide athletic coaching services or other academic coaching services upon request. The need to submit to a criminal history background check may be included with the basic criteria for employment or provision of services in the position posting and position advertisements.
- H. The individual will be informed of the results of the criminal background check(s) to the extent required by law.
- I. If the criminal history background check precludes employment with, or provision of services to, the school district, the individual will be so advised.
- J. The school district may apply these procedures to other volunteers, independent contractors, student employees, student teachers, and administrative interns.
- K. At the beginning of each school year or when a student enrolls, the school district will notify parents and guardians about this policy and identify those positions subject to a background check and the extent of the school district's discretion in requiring a background check. The school district may include this notice in its student handbook, a school policy guide, or other similar communication. A form notice for this purpose is included with this policy.

#### **IV. CRIMINAL HISTORY CONSENT FORM**

A form to obtain consent for a criminal history background check can be obtained from the Human Resource Department.

**Legal References:** Minn. Stat. § 13.04, Subd. 4 (Inaccurate or Incomplete Data)

Minn. Stat. § 13.87, Subd. 1 (Criminal History Data)  
Minn. Stat. § 123B.03 (Background Check)  
Minn. Stat. §§ 299C.60-299C.64 (Minnesota Child Protection Background  
Check Act)  
Minn. Stat. § 364.09(b) (Exception for School Districts)

***Cross References:***

*Adopted:* 9/10/2015  
*Reviewed:* 1/11/2018  
*Revised:* 1/25/2018  
*Rescinds:*

## **424 LICENSE STATUS**

### **I. PURPOSE**

The purpose of this policy is to ensure that qualified teachers are employed by the school district and to fulfill its duty to ascertain the licensure status of its teachers. A school district that employs a teacher who does not hold a valid teaching license or permit places itself at risk for a reduction in state aid. This policy does not negate a teacher's duty and responsibility to maintain a current and valid teaching license.

### **II. GENERAL STATEMENT OF POLICY**

- A. A qualified teacher is one holding a valid license to perform the particular service for which the teacher is employed by the school district.
- B. No person shall be a qualified teacher until the school district verifies through the Minnesota education licensing system available on the Minnesota Department of Education website that the person is a qualified teacher consistent with state law.
- C. The school district has a duty to ascertain the licensure status of its teachers and ensure that the school district's teacher license files are up to date. The school district shall establish a procedure for annually reviewing its teacher license files to verify that every teacher's license is current and appropriate to the particular service for which the teacher is employed by the school district.

### **III. PROCEDURE**

- A. The superintendent or the superintendent's designee shall establish a schedule for the annual review of teacher licenses.
- B. Where it is discovered that a teacher's license will expire within one year from the date of the annual review, the superintendent or the superintendent's designee will advise the teacher in writing of the approaching expiration and that the teacher must complete the renewal process and file the license with the superintendent prior to the expiration of the current license. However, failure to provide this notice does not relieve a teacher from his/her duty and responsibility of ensuring that his/her teaching license is valid, current and appropriate to his/her teaching assignment.
- C. If it is discovered that a teacher's license has expired, the superintendent or designee will immediately investigate the circumstances surrounding the lack of license and will take appropriate action. The teacher shall be advised that the

teacher's failure to have the license reinstated will constitute gross insubordination, inefficiency and willful neglect of duty which are grounds for immediate discharge from employment.

- D. The duty and responsibility of maintaining a current and valid teaching license appropriate to the teaching assignment as required by this policy shall remain with the teacher, notwithstanding the superintendent's failure to discover a lapsed license or license that does not support the teaching assignment. A teacher's failure to comply with this policy may be grounds for the teacher's immediate discharge from employment.

***Legal References:*** Minn. Stat. § 122A.16 (Highly Qualified Teacher Defined)  
Minn. Stat. § 122A.22 (District Verification of Teacher Licenses)  
Minn. Stat. § 122A.40, Subd. 13 (Employment; Contracts; Termination – Immediate Discharge)  
Minn. Stat. § 127A.42 (Reduction of Aid for Violation of Law)  
*Vettleson v. Special Sch. Dist. No. 1*, 361 N.W.2d 425 (Minn. App. 1985)  
*Lucio v. School Bd. of Independent Sch. Dist. No. 625*, 574 N.W.2d 737 (Minn. App. 1998)  
*In the Matter of the Proposed Discharge of John R. Statz* (Christine D. VerPloeg), June 8, 1992, *affirmed*, 1993 WL 129639 (Minn. App. 1993)

***Cross References:***

*Adopted: 1996*  
*Reviewed: 1/11/2018*  
*Revised: 1/25/2018*  
*Rescinds: ACC and JBC*

*Burnsville-Eagan-Savage School District Policy 521*

**521 STUDENT DISABILITY NONDISCRIMINATION**

**I. PURPOSE**

The purpose of this policy is to protect students with a disability from discrimination on the basis of disability and to identify and evaluate individuals who, within the intent of Section 504 of the Rehabilitation Act of 1973 (Section 504), need services, accommodations, or programs in order that such individuals may receive a free appropriate public education.

**II. GENERAL STATEMENT OF POLICY**

- A. Burnsville-Eagan-Savage School District provides equal educational opportunity to all qualified individuals. Students with a disability who meet the criteria of Paragraph C. below are protected from discrimination on the basis of a disability.
- B. The Board of Education is committed to identifying and evaluating qualified individuals who, within the intent of Section 504, may need services, accommodations, or programs in order that such individuals may receive a free appropriate public education.
- C. For this policy, a student who is protected under Section 504 is one who:
  - 1. has a physical or mental impairment that substantially limits one or more major life activity, including learning; or
  - 2. has a record of such an impairment; or
  - 3. is regarded as having such an impairment, and
  - 4. who is of the age for which non-disabled persons are provided educational services; or
  - 5. who is of an age of which it is mandatory under state law to provide such services to disabled individuals; or
  - 6. who is required to receive a free appropriate public education under the Individuals with Disabilities Education Improvement Act.
- D. Learners may be protected from disability discrimination and be eligible for services, accommodations, or programs under the provisions of Section 504 even

though they are not eligible for special education pursuant to the Individuals with Disabilities Education Improvement Act.

### **III. COORDINATOR**

Persons who have questions or comments should contact Stephanie White, Director of Individualized Student Services, 200 West Burnsville Parkway, Burnsville, MN 55337, 952-707-6261, stwhite@isd191.org. This person is the school district's Section 504 coordinator. Persons who wish to make a complaint regarding a disability discrimination matter may contact the Director of Individualized Student Services.

***Legal References:*** Pub. L. 110-325, 122 Stat. 3553 (ADA Amendments Act of 2008, § 7)  
29 U.S.C. § 794 *et seq.* (Rehabilitation Act of 1973, § 504)  
34 C.F.R. Part 104 (Section 504 Implementing Regulations)  
20 U.S.C. § 1400 *et seq.* (Individuals with Disabilities Education Improvement Act of 2004)

***Cross References:*** Burnsville-Eagan-Savage School District Policy 402 (Disability Nondiscrimination)

*Adopted:* 4/1997  
*Reviewed:* 1/11/2018  
*Revised:* 1/25/2018  
*Rescinds:* IKF

*Burnsville-Eagan-Savage School District Policy 620*

**620 CREDIT FOR LEARNING**

**I. PURPOSE**

The purpose of this policy is to recognize student achievement which occurs in Post-Secondary Enrollment Options and other advanced enrichment programs. The purpose of this policy also is to recognize student achievement which occurs in other schools, in alternative learning sites, and in out-of-school experiences such as community organizations, work-based learning, and other educational activities and opportunities. The purpose of this policy also is to address the transfer of student credit from out-of-state, private, or home schools and online learning programs and to address how the school district will recognize student achievement obtained outside of the school district.

**II. GENERAL STATEMENT OF POLICY**

The policy of the school district is to provide a process for awarding students credit toward graduation requirements for credits and grades students complete in other schools, post-secondary or higher education institutions, other learning environments, and online courses and programs.

**III. DEFINITIONS**

- A. “Accredited school” means a school that is accredited by an accrediting agency, recognized according to Minn. Stat. § 123B.445 or recognized by the Commissioner of the Minnesota Department of Education (MDE).
- B. “Blended learning” is a form of digital learning that occurs when a student learns part time in a supervised physical setting and part time through digital delivery of instruction, or a student learns in a supervised physical setting where technology is used as a primary method to deliver instruction.
- C. “Commissioner” means the Commissioner of MDE.
- D. “Digital learning” is learning facilitated by technology that offers students an element of control over the time, place, path, or pace of their learning and includes blended and online learning.
- E. “Eligible institution” means a Minnesota public post-secondary institution, a private, nonprofit two-year trade and technical school granting associate degrees, an opportunities industrialization center accredited by the North Central Association of Colleges and Schools, or a private, residential, two-year or four-

year, liberal arts, degree-granting college or university located in Minnesota.

- F. “Nonpublic school” is a private school or home school in which a child is provided instruction in compliance with the Minnesota compulsory attendance laws.
- G. “Online learning” is a form of digital learning delivered by an approved online learning provider.
- H. “Online learning provider” is a school district, an intermediate school district, an organization of two or more school districts operating under a joint powers agreement, or a charter school located in Minnesota that provides online learning to students and is approved by MDE to provide online learning courses.

I.

#### **IV. TRANSFER OF CREDIT FROM OTHER SCHOOLS**

A. Transfer of Academic Requirements from Other Minnesota Public Secondary Schools

The school district will accept and transfer secondary credits and grades awarded to a student from another Minnesota public secondary school upon presentation of a certified transcript from the transferring public secondary school evidencing the course taken and the grade and credit awarded.

B. Transfer of Academic Requirements from Other Schools

- 1. The school district will accept secondary credits and grades awarded to a student for courses successfully completed at a public school outside of Minnesota or an accredited nonpublic school upon presentation of a certified transcript from the transferring public school in another state or nonpublic school evidencing the course taken and the grade and credit awarded.
  - a. When a determination is made that the content of the course aligns directly with school district graduation requirements, the student will be awarded commensurate credits and grades.
  - b. In the event the content of a course taken at an accredited nonpublic school or public school in another state does not fully align with the content of the school district’s high school graduation requirements but is comparable to elective credits offered by the school district for graduation, the student may be provided elective credit applied toward graduation requirements. Credit that does not fully align with the school district’s high school graduation requirements will not be used to compute honor roll and/or class rank.

- c. If no comparable course is offered by the school district for which high school graduation credit would be provided, no credit will be provided to the student.
- 2. Students transferring from a non-accredited, nonpublic school shall receive credit from the school district upon presentation of a transcript or other documentation evidencing the course taken and grade and credit awarded.
  - a. Students will be required to provide copies of course descriptions, syllabi, or work samples for determination of appropriate credit. In addition, students also may be asked to provide interviews/conferences with the student and/or student's parent and/or former administrator or teacher; review of a record of the student's entire curriculum at the nonpublic school; and review of the student's complete record of academic achievement.
  - b. Where the school district determines that a course completed by a student at a non-accredited, nonpublic school is commensurate with school district graduation requirements, credit shall be awarded, but the grade shall be "P" (pass).
  - c. In the event the content of a course taken at an non-accredited, nonpublic school does not fully align with the content of the school district's high school graduation requirements but is comparable to elective credits offered by the school district for graduation, the student may be provided elective credit applied toward graduation requirements, but the grade shall be a "P" (pass).
  - d. If no comparable course is offered by the school district for which local high school graduation credit would be provided, no credit will be provided to the student.
  - e. Credit and grades earned from a non-accredited nonpublic school shall not be used to compute honor roll and/or class rank.

**V. POST-SECONDARY ENROLLMENT CREDIT**

- A. A student who satisfactorily completes a post-secondary enrollment options course or program under Minn. Stat. § 124D.09 that has been approved as meeting the necessary requirements is not required to complete other requirements of the Minnesota Academic Standards content standards corresponding to that specific rigorous course of study.
- B. Secondary credits granted to a student through a post-secondary enrollment options course or program that meets or exceeds a graduation standard or requirement shall be counted toward the graduation and credit requirements of a

student completing the Minnesota Academic Standards.

1. Course credit will be considered by the school district only upon presentation of a certified transcript from an eligible institution evidencing the course taken and the grade and credit awarded.
  2. Seven quarter or four semester post-secondary credits shall equal at least one full year of high school credit. Fewer post-secondary credits may be prorated.
  3. When a determination is made that the content of the post-secondary course aligns directly with a required course for high school graduation, the commensurate credit and grade will be recorded on the student's transcript as a course credit applied toward graduation requirements.
  4. In the event the content of the post-secondary course does not fully align with the content of a high school course required for graduation but is comparable to elective credits offered by the school district for graduation, the school district may provide elective credit and the grade will be recorded on the student's transcript as an elective course credit applied toward graduation requirements.
  5. If no comparable course is offered by the school district for which high school graduation credit would be provided, the school district will notify the Commissioner, who shall determine the number of credits that shall be granted to a student.
  6. When secondary credit is granted for post-secondary credits taken by a student, the school district will record those credits on the student's transcript as credits earned at a post-secondary institution.
- C. A list of the courses or programs meeting the necessary requirements may be obtained from the school district.

## **VI. CREDIT FROM ONLINE LEARNING COURSES**

- A. Secondary credits granted to a student through an online learning course or program that meets or exceeds a graduation standard or requirement shall be counted toward the graduation and credit requirements of a student completing the Minnesota Academic Standards.
- B. Course credit will be considered only upon official documentation from the online learning provider evidencing the course taken and the grade and credit awarded to the student.
- C. When a student provides documentation from an online learning provider, the course credit and course grade shall be recorded and counted toward graduation credit requirements for all courses or programs that meet or exceed the school

district's graduation requirements in the same manner as credits are awarded for students transferring from another Minnesota public school as set forth in Section IV.A. above.

## **VII. ADVANCED ACADEMIC CREDIT**

- A. The school district will grant academic credit to a student attending an accelerated or advanced academic course offered by a higher education institution or a nonprofit public agency, other than the school district.
- B. Course credit will be considered only upon official documentation from the higher education institution or nonprofit public agency that the student successfully completed the course attended and passed an examination approved by the school district.
- C. When a determination is made that the content of the advanced academic course aligns directly with a required course for high school graduation, the commensurate credit and grade will be recorded on the student's transcript as a course credit applied toward graduation requirements.
- D. In the event the content of the advanced academic course does not fully align with the content of a high school course required for graduation but is comparable to elective credits offered by the school district for graduation, the school district may provide elective credit and the grade will be recorded on the student's transcript as an elective course credit applied toward graduation requirements.
- E. If no comparable course is offered by the school district for which high school graduation credit would be provided, the school district will notify the Commissioner and request a determination of the number of credits that shall be granted to a student.

## **VIII. WEIGHTED GRADES**

[Note: School districts must identify in policy whether they offer courses with weighted grades. Therefore, school districts must include one of the following options in their policies.]

- A. The school district does not offer weighted grades.

## **IX. PROCESS FOR AWARDING CREDIT**

- A. The building principal will be responsible for carrying out the process to award credits and grades pursuant to this policy. The building principal will notify students in writing of the decision as to how credits and grades will be awarded.
- B. A student or the student's parent or guardian may seek reconsideration of the decision by the building principal as to credits and/or grades awarded upon

request of a student or the student's parent or guardian if the request is made in writing to the superintendent within five school days of the date of the building principal's decision. The request should set forth the credit and/or grade requested and the reason(s) why credit(s)/grade(s) should be provided as requested. Any pertinent documentation in support of the request should be submitted.

- C. The decision of the superintendent as to the award of credits or grades shall be a final decision by the school district and shall not be appealable by the student or student's parent or guardian except as set forth in Section IX.D. below.
- D. If a student disputes the number of credits granted by the school district for a particular post-secondary enrollment course, online learning course, or advanced academic credit course, the student may appeal the school district's decision to the Commissioner. The decision of the Commissioner shall be final.
- E. At any time during the process, the building principal or superintendent may ask for course descriptions, syllabi, or work samples from a course where content of the course is in question for purposes of determining alignment with graduation requirements or the number of credits to be granted. Students will not be provided credit until requested documentation is available for review, if requested.

**Legal References:** Minn. Stat. § 120B.02 (Educational Expectations for Minnesota's Students)  
Minn. Stat. § 120B.021 (Required Academic Standards)  
Minn. Stat. § 120B.11 (School District Process)  
Minn. Stat. § 120B.14 (Advanced Academic Credit)  
Minn. Stat. § 123B.02 (General Powers of Independent School Districts)  
Minn. Stat. § 123B.445 (Nonpublic Education Council)  
Minn. Stat. § 124D.03, Subd. 9 (Enrollment Options Program)  
Minn. Stat. § 124D.09 (Post-Secondary Enrollment Options Act)  
Minn. Stat. § 124D.095 (Online Learning Option)  
Minn. Rules Parts 3501.0640-3501.0655 (Academic Standards for Language Arts)  
Minn. Rules Parts 3501.0700-3501.0745 (Academic Standards for Mathematics)  
Minn. Rules Parts 3501.0800-3501.0815 (Academic Standards for the Arts)  
Minn. Rules Parts 3501.0900-3501.0955 (Academic Standards in Science)  
Minn. Rules Parts 3501.1000-3501.1190 (Graduation-Required Assessment for Diploma) (repealed Minn. L. 2013, Ch. 116, Art. 2, § 22)  
Minn. Rules Parts 3501.1200-3501.1210 (Academic Standards for English Language Development)  
Minn. Rules Parts 3501.1300-3501.1345 (Academic Standards for Social Studies)

**Cross References:** Burnsville-Eagan-Savage School District Policy 104 (School District Mission Statement)

Burnsville-Eagan-Savage School District Policy 601 (School District Curriculum and Instruction Goals)

Burnsville-Eagan-Savage School District Policy 613 (Graduation Requirements)

Burnsville-Eagan-Savage School District Policy 614 (School District Testing Plan and Procedure)

Burnsville-Eagan-Savage School District Policy 615 (Testing Accommodations, Modifications, and Exemptions for IEPs, Section 504 Plans, and LEP Students)

Burnsville-Eagan-Savage School District Policy 616 (School District System Accountability)

Burnsville-Eagan-Savage School District Policy 618 (Assessment of Student Achievement)

Burnsville-Eagan-Savage School District Policy 624 (Online Learning Options)

*Adopted:* 6/1986  
*Reviewed:* 1/11/2018  
*Revised:* 1/25/2018  
*Rescinds:* KK

## **903 VISITORS TO SCHOOL DISTRICT BUILDINGS AND SITES**

### **I. PURPOSE**

The purpose of this policy is to inform the school community and the general public of the position of the school board on visitors to school buildings and other school property.

### **II. GENERAL STATEMENT OF POLICY**

- A. The school board encourages interest on the part of parents and community members in school programs and student activities. The school board welcomes visits to school buildings and school property by parents and community members provided the visits are consistent with the health, education and safety of students and employees and are conducted within the procedures and requirements established by the school district.
- B. The school board reaffirms its position on the importance of maintaining a school environment that is safe for students and employees and free of activity that may be disruptive to the student learning process or employee working environment.

### **III. POST-SECONDARY ENROLLMENT OPTIONS STUDENTS**

- A. A student enrolled in a post-secondary enrollment options course may remain at the school site during regular school hours in accordance with established procedures.
- B. A student enrolled in a post-secondary enrollment options course may be provided with reasonable access, during regular school hours, to a computer and other technology resources that the student needs to complete coursework for a post-secondary enrollment course in accordance with established procedures.

### **IV. RESPONSIBILITY**

- A. The school district administration will develop visitor and post-secondary enrollment options student procedures and requirements.
- B. The superintendent or designee shall be responsible for providing coordination that may be needed throughout the process and providing for periodic school board review and approval of the procedures.

### **V. VISITOR LIMITATIONS**

- A. An individual, post-secondary enrollment options student, or group may be denied permission to visit a school or school property or such permission may be revoked if the visitor(s) does not comply with the school district procedures and regulations or if the visit is not in the best interest of students, employees or the school district.
- B. Visitors, including post-secondary enrollment options students, are authorized to park vehicles on school property at times and in locations specified in the approved visitor procedures and requirements which are an addendum to this policy or as otherwise specifically authorized by school officials. When unauthorized vehicles of visitors are parked on school property, school officials may:
  - 1. move the vehicle or require the driver or other person in charge of the vehicle to move it off school district property; or
  - 2. if unattended, provide for the removal of the vehicle, at the expense of the owner or operator, to the nearest convenient garage or other place of safety off of school property.
- C. An individual, post-secondary enrollment options student, or group who enters school property without complying with the procedures and requirements may be guilty of criminal trespass and thus subject to criminal penalty. Such persons may be detained by the school principal or a person designated by the school principal in a reasonable manner for a reasonable period of time pending the arrival of a police officer.

***Legal References:*** Minn. Stat. § 123B.02 (General Powers of Independent School Districts)  
Minn. Stat. § 124D.09 (Post-Secondary Enrollment Options Program)  
Minn. Stat. § 128C.08 (Assaulting a Sports Official Prohibited)  
Minn. Stat. § 609.605, Subd. 4 (Trespasses on School Property)

***Cross References:***



**Future Ready. Community Strong.**

**Agenda V.A.  
January 25, 2018**

**To:** Board of Education  
Cindy Amoroso, Superintendent

**From:** Dave Watkins, Assistant Superintendent and Bri Ostoff, Youth Service Coordinator

**Date:** January 18, 2018

**Re:** Approve Initial Extended Field Trip Request for Burnsville High School Students to Travel to Ecuador During Spring Break 2019

**Recommendation:** That the Board of Education approves an application for an initial extended field trip request for Burnsville High School students to travel to Ecuador during Spring Break 2019 (March 23-31 plus two days).

- Staff sponsors: Brianna Ostoff, Allison Millea, and Dave McDevitt.
- Description of the proposed program: This trip will be with Education First partnered with ME to WE and Free the Children. Five days of the trip will be in a village in Ecuador doing a service project for Free the Children (part of We Days global impact.)
- The educational objectives of the trip:
  - Opportunities for global service learning
  - Participate in local “Minga” (bring individuals together to work for the betterment of the group).
  - Having students experience a culture different than theirs.
- Estimated number of participants: 28 students and 3 chaperones.
- Anticipated cost of the trip per student: \$3910.
- Provisions for students whom financing the trip is an issue: We plan on doing multiple fundraising events, we have a fundraising plan with the travel company. We want this to be an equitable opportunity so we want to build the group now for fundraising.



**Future Ready. Community Strong.**

**Agenda V. B.  
January 25, 2018**

**TO:** Members, Board of Education  
**FROM:** Lisa K. Rider, Executive Director of Business Services  
**DATE:** January 19, 2018  
**RE:** Approve 2017-18 Revised Budget

**RECOMMENDATION:** That the Board of Education approves the 2017-18 Revised Budget providing revenues and expenditures in all funds as follows:

<u>Fund</u>	<u>Revenue</u>	<u>Expenditure</u>	<u>Net Increase (Decrease)</u>
General	126,406,866.00	130,846,390.00	\$ (4,439,524)
Food Service	5,833,664.00	5,934,300.00	(100,636)
Community Service	7,034,684.00	7,036,676.00	(1,992)
Capital Projects	98,000.00	5,391,764.00	(5,293,764)
Debt Service	10,878,368.00	43,231,861.00	(32,353,493)
Total Governmental	<u>150,251,582.00</u>	<u>192,440,991.00</u>	<u>(42,189,409)</u>
Trust & Agency	840,000.00	830,000.00	10,000
Internal Service	<u>22,412,591.00</u>	<u>23,162,328.00</u>	<u>(749,737)</u>
All Funds	<u><u>173,504,173.00</u></u>	<u><u>216,433,319.00</u></u>	<u><u>\$ (42,929,146)</u></u>

Each fiscal year the budget is revised to reflect the most current information available with respect to revenues and expenditures. This recommendation formally recognizes these revisions by incorporating them into the budget document. Revisions have been made in all governmental funds.

Following is a brief explanation of the more substantive revisions:

## General Fund

- Acknowledged decreasing general enrollment is essentially offset by the more aggressive assumption for extended time and the addition of the Voluntary Pre-Kindergarten program implemented this fall.
- Increased Special Education Revenue by \$450,000 based on state report forecast from November, 2017.
- Budget carryovers from the prior year as committed by the Board of Education.
- Revenue and expenditure budget changes related to final federal funding allocations for fiscal year 2018, including amounts carried forward from fiscal year 2017.
- Overall increase in General Fund FTE's of 4.0 from Adopted moved from Fund 04 tied to Voluntary Pre-Kindergarten program expansion.
- Adjustments for more accurate expenditure estimates.

The impact of these revisions results in a projected decrease in ending total fund balance of \$4,439,524. The projected unassigned fund balance as a percent of general fund total expenditures for June 30, 2018 is approximately 8.0%.

## Food Service Fund

The food service revenues and expenditures have been revised for more accurate assumptions based on updated personnel costs. These adjustments continue to show a projected decrease in fund balance.

## Community Service Fund

The community service revenues and expenditures have been revised for more accurate assumptions based on prior year trends, experiences, and changes in programming, including the addition of Campus Cup effective FY17.

## Debt Service Fund

The debt service revenues and expenditures have been reviewed and accurately reflect principal and interest payments, including the necessary refunding payments.

I recommend approval of the 2017-18 Revised Budget.

# General Fund Budget Comparative Summary

	Actual Results 2014-15	Actual Results 2015-16	Actual Results 2016-17	Adopted Budget 2017-18	Revised Budget 2017-18
<b>Total Beginning Fund Balance</b>	\$ 21,960,591	\$ 20,677,866	\$ 21,629,697	\$ 20,049,406	\$ 20,116,731
<b>Revenues</b>	119,103,906	121,221,618	124,590,035	125,839,549	126,406,866
<b>Expenditures</b>	120,386,631	120,269,787	126,103,001	130,598,185	130,846,390
<b>Variance (Revenues - Expenditures)</b>	(1,282,725)	951,831	(1,512,966)	(4,758,636)	(4,439,524)
<b>Total Ending Fund Balance</b>	\$ 20,677,866	\$ 21,629,697	\$ 20,116,731	\$ 15,290,770	\$ 15,677,207
<b>Breakdown of Fund Balance Categories</b>					
<b>Nonspendable</b>	\$ 647,352	\$ 508,867	\$ 328,969	\$ 508,867	\$ 328,969
<b>Restricted</b>	3,787,467	4,196,553	4,026,734	4,216,853	3,819,380
<b>Committed</b>	1,393,434	1,176,269	1,293,947	812,139	1,056,051
<b>Unassigned</b>	14,849,613	15,748,007	14,467,081	9,752,911	10,472,807
<b>Total Ending Fund Balance</b>	\$ 20,677,866	\$ 21,629,697	\$ 20,116,731	\$ 15,290,770	\$ 15,677,207
<b>Unassigned Fund Balance %</b>	12.33%	13.09%	11.47%	7.47%	8.00%

101

# 2018 Revised Budget by Budget Unit

(staffing and budgeted FTE as of Dec 18, 2017)

		2018	
		Adopted Budget	Revised Budget
<b>01010</b>	<b>- General Elementary Instruction - Personnel</b>	17,888,499	17,779,759
Provides the funding necessary to provide instruction in the core academic subjects of language arts, math, and social studies at the district's ten elementary schools.			
This budget unit consists of salaries and benefits for <a href="#">174.00</a> FTEs.			
<b>01030</b>	<b>- General Elementary Instruction - Subs</b>	408,000	408,000
Provides the funding necessary for elementary substitutes.			
This budget unit consists of salaries and benefits for <a href="#">no</a> FTEs.			
<b>02010</b>	<b>- General Middle School Instruction - Personnel</b>	6,272,823	6,226,866
Provides the funding necessary to offer courses in the core academic subjects of language arts, math, science, social studies, and world language at the district's three middle schools.			
This budget unit consists of salaries and benefits for <a href="#">56.72</a> FTEs.			
<b>02020</b>	<b>- General Middle School Instruction - Subs</b>	286,000	286,000
Provides the funding necessary for middle school substitutes.			
This budget unit consists of salaries and benefits for <a href="#">no</a> FTEs.			
<b>03010</b>	<b>- General High School Instruction - Personnel</b>	7,921,907	7,820,741
Provides the funding necessary to offer courses in the core academic subjects of language arts, math, science, social studies, and world language at the district's senior high.			
This budget unit consists of salaries and benefits for <a href="#">72.80</a> FTEs.			
<b>03020</b>	<b>- General High School Instruction - Subs</b>	200,000	200,000
Provides the funding necessary for high school substitutes.			
This budget unit consists of salaries and benefits for <a href="#">no</a> FTEs.			
<b>04010</b>	<b>- PhyEd, Health, Art, Music - Personnel</b>	5,237,852	5,252,147
Provides the funding to provide K-12 physical education, 6-12 health, K-12 visual arts, K-12 general/vocal music, and 6-12 Instructional music instruction.			
This budget unit consists of salaries and benefits for <a href="#">56.79</a> FTEs.			
<b>05010</b>	<b>- Long Term Subs</b>	386,255	384,950
Provides the funding necessary for payment of Long Term Subs K-12.			
This budget unit consists of salaries and benefits for <a href="#">no</a> FTEs.			

## 2018 Revised Budget by Budget Unit

<b>06010</b>	<b>- Family and Consumer Science Instruction</b>	628,236	528,302
Provides the funding to operate the instructional program of family and consumer science.			
This budget unit consists of salaries and benefits for <a href="#">7.83</a> FTEs.			
<b>06020</b>	<b>- Trade and Industrial Education</b>	600,580	615,471
Provides the funding to operate the instructional program of trade and industrial education.			
This budget unit consists of salaries and benefits for <a href="#">6.10</a> FTEs.			
<b>06040</b>	<b>- Business and Office Education</b>	524,048	547,242
Provides the funding to operate the instructional program of business and office education.			
This budget unit consists of salaries and benefits for <a href="#">5.80</a> FTEs.			
<b>06050</b>	<b>- Partnerships</b>	227,908	227,738
Provides the funding for Strategic Partnerships and Pathways and related efforts in connecting our students with community opportunities.			
This budget unit consists of salaries and benefits for <a href="#">1.75</a> FTEs.			
<b>06060</b>	<b>- Post-Secondary Tuition</b>	276,000	276,000
Provides the budget for secondary students to attend classes through the District's various University and College programs including college in the schools (CIS) and post-secondary enrollment options (PSEO).			
This budget unit consists of salaries and benefits for <a href="#">no</a> FTEs.			
<b>06070</b>	<b>- Post-Secondary - Career Tech Tuition</b>	474,000	474,000
Provides the budget for secondary students to attend Career tech classes.			
This budget unit consists of salaries and benefits for <a href="#">no</a> FTEs.			
<b>07010</b>	<b>- K-12 Media Services</b>	831,726	848,212
Provides the funding to provide K-12 media services- media specialists and media educational assistants.			
This budget unit consists of salaries and benefits for <a href="#">13.50</a> FTEs.			
<b>07020</b>	<b>- K-12 Gifted and Talented</b>	695,742	673,226
Provides the funding to provide for a half-time gifted and talented instructor at each elementary school and an additional 1.0 at the gifted and talented magnet school.			
This budget unit consists of salaries and benefits for <a href="#">5.80</a> FTEs.			

## **2018 Revised Budget by Budget Unit**

<b>07030</b>	<b>- 6-12 Guidance Services</b>	1,416,436	1,401,659
Provides the funding to provide 6-12 guidance services.			
This budget unit consists of salaries and benefits for <a href="#">13.00</a> FTEs.			
<b>07040</b>	<b>- 9-12 Deans</b>	636,255	497,078
Provides the funding to provide 9-12 Dean support.			
This budget unit consists of salaries and benefits for <a href="#">6.00</a> FTEs.			
<b>07060</b>	<b>- English Second Language Learner</b>	3,814,585	3,777,007
Provides funding for the district's K-12 English Second Language Learner program and includes salaries, benefits, and other instructional expenses.			
This budget unit consists of salaries and benefits for <a href="#">41.30</a> FTEs.			
<b>08010</b>	<b>- Site Allocation of Instructional/Operational Resources</b>	512,737	727,280
Provides the per pupil funding allocation for instructional and operational related expenses. This funding is intended to cover the costs of building level equipment repairs, purchase of general supplies, classroom supplies, telephone, etc.			
This budget unit consists of salaries and benefits for <a href="#">no</a> FTEs.			
<b>08020</b>	<b>- Building Level Copier Leases</b>	102,910	102,910
Provides the funding for the monthly lease costs of the main multi-functional device within each school.			
This budget unit consists of salaries and benefits for <a href="#">no</a> FTEs.			
<b>09010</b>	<b>- Special Ed Salaries/Benefits</b>	24,622,273	24,085,170
Provides funding for staff costs necessary to operate the Office of Individualized Student Services. Most, but not all of these expenditures, are either reimbursed with state or federal special education funds or are related to general education functions.			
This budget unit consists of salaries and benefits for <a href="#">327.60</a> FTEs.			
<b>09030</b>	<b>- Special Ed Purchased Services</b>	1,772,382	1,559,385
Provides funding for Individualized Student Services purchased services, supplies and equipment.			
This budget unit consists of salaries and benefits for <a href="#">no</a> FTEs.			
<b>09040</b>	<b>- Special Ed Transportation</b>	3,793,000	3,904,976
Required transportation, purchased services, supplies and equipment for students served by Individualized Student Services.			
This budget unit consists of salaries and benefits for <a href="#">no</a> FTEs.			

## **2018 Revised Budget by Budget Unit**

<b>10010</b>	<b>- Alternative Learning Center</b>	3,872,516	4,184,987
Provides categorical funds to operate the alternative high school, school within a school, extended day and extended year programs for elementary and middle school students.			
This budget unit consists of salaries and benefits for <a href="#">32.17</a> FTEs.			
<b>10020</b>	<b>- Mental Health Services</b>	260,000	260,000
Licensed mental health professionals, through a financial partnership with Headway, who are able to respond to pressing mental health needs, proactively support student success, and be readily available in case of a crisis.			
This budget unit consists of salaries and benefits for <a href="#">no</a> FTEs.			
<b>10030</b>	<b>- K-12 Nursing/Health Services</b>	979,064	1,020,228
Provides funding to operate the district health services department including salaries, benefits and other operating expenses for the district school health offices. Certain FTEs may also be included in Special Ed Salaries, 09010.			
This budget unit consists of salaries and benefits for <a href="#">10.45</a> FTEs.			
<b>11010</b>	<b>- Co-Curricular Activities (Non-Athletic)</b>	446,333	472,732
Provides the funding to support co-curricular activities. These funds are supplemented through ticket sales, fund raising, donations, etc.			
This budget unit consists of salaries and benefits for <a href="#">1.83</a> FTEs.			
<b>11020</b>	<b>- High School Interscholastic Athletics</b>	1,346,297	1,240,000
Provides the funding to provide high school athletics. These funds are supplemented through ticket sales, fund raising, donations, etc.			
This budget unit consists of salaries and benefits for <a href="#">2.38</a> FTEs.			
<b>11021</b>	<b>- Middle School Interscholastic Athletics</b>	179,684	157,391
Provides the funding to provide middle school athletics. These funds are supplemented through ticket sales, fund raising, donations, etc.			
This budget unit consists of salaries and benefits for <a href="#">no</a> FTEs.			
<b>12010</b>	<b>- Title I, Part A Regular - Improving Basic Programs</b>	1,500,000	1,737,282
Provides funding to help ensure all children meet challenging state academic standards. Includes staffing, instructional, Supplemental Education Services and staff development expenses.			
This budget unit consists of salaries and benefits for <a href="#">18.23</a> FTEs.			
<b>12020</b>	<b>- Title II, Part A Regular - Teacher/Principal Training &amp; Recruiting</b>	240,000	325,906
Funding pays a portion of teacher and administrative salaries of highly qualified professionals working to improve student achievement.			
This budget unit consists of salaries and benefits for <a href="#">0.50</a> FTEs.			

## **2018 Revised Budget by Budget Unit**

<b>12030</b>	<b>- Title III Regular - Limited English Proficient Students</b>	180,000	192,244
Funding supports ESL personnel, their professional development, and for interpretation needs of our LEP families.			
This budget unit consists of salaries and benefits for <a href="#">1.50</a> FTEs.			
<b>12050</b>	<b>- Carl Perkins Grant</b>	68,000	43,750
Funding pays for professional development and supplies to teachers of Family and Consumer Science, Business, and Technology Education at Burnsville Senior High School.			
This budget unit consists of salaries and benefits for <a href="#">no</a> FTEs.			
<b>13010</b>	<b>- Q-Comp/Pro-Pay</b>	2,369,609	2,507,506
Provides for expenditures associated with the district's Q-Comp / Pro-Pay programs including salaries and benefits, stipends, performance incentives and other operating expenses.			
This budget unit consists of salaries and benefits for <a href="#">7.00</a> FTEs.			
<b>13020</b>	<b>- Integration and Achievement</b>	1,955,806	1,906,712
Provides for expenditures related to the integration and achievement program including salaries and benefits, professional development and other operating expenses.			
This budget unit consists of salaries and benefits for <a href="#">22.60</a> FTEs.			
<b>13030</b>	<b>- Compensatory Education</b>	2,494,311	2,693,982
Provides funding for compensatory programs and initiatives to meet the educational needs of students who are under prepared or are not meeting age appropriate performance standards.			
This budget unit consists of salaries and benefits for <a href="#">33.19</a> FTEs.			
<b>14010</b>	<b>- Technology</b>	2,508,801	2,539,217
Provides funding to manage and support the district's technologies including digital learning specialist, instructional, operational resources, equipment and supplies including the District's intranet and telephone systems.			
This budget unit consists of salaries and benefits for <a href="#">11.00</a> FTEs.			
<b>14020</b>	<b>- Technology: Capital Levy</b>	2,544,339	2,560,131
Provides funding of technical staff, 1:1 initiative, and technical training of instructional staff.			
This budget unit consists of salaries and benefits for <a href="#">13.00</a> FTEs.			
<b>15010</b>	<b>- Instructional Development</b>	602,989	434,510
Provides the funding for district professional development (PD) to support the acquisition of district learning goals. Includes operational resources, purchased services, equipment, supplies, and building level PD allocations.			
This budget unit consists of salaries and benefits for <a href="#">no</a> FTEs.			

## 2018 Revised Budget by Budget Unit

<b>15020</b>	<b>- Curriculum Development</b>	757,627	871,956
Provides the funding for the ongoing development of a comprehensive written curriculum. Also includes operational resources, purchased services, equipment and supplies.			
This budget unit consists of salaries and benefits for <a href="#">4.36</a> FTEs.			
<b>15030</b>	<b>- Curriculum Adoptions</b>	750,000	896,478
Provides the funding for the purchase of curriculum resources to support delivery of the written curriculum including textbooks, manipulatives, software and software subscriptions.			
This budget unit consists of salaries and benefits for <a href="#">no</a> FTEs.			
<b>15040</b>	<b>- Assessment Program</b>	465,652	466,461
Provides the funding necessary to implement required accountability assessments to monitor student progress toward achievement of academic standards through software fees, purchased services, equipment and supplies.			
This budget unit consists of salaries and benefits for <a href="#">1.25</a> FTEs.			
<b>16010</b>	<b>- Board of Education</b>	142,178	142,178
Provides the funding for the School Board. Includes School Board stipends, District elections, legal fees and other expenses related to Board initiatives.			
This budget unit consists of salaries and benefits for <a href="#">no</a> FTEs.			
<b>16020</b>	<b>- Superintendent</b>	485,376	461,598
Provides the funding to operate the office of Superintendent of Schools to support the District's mission, vision, and instructional goals.			
This budget unit consists of salaries and benefits for <a href="#">2.00</a> FTEs.			
<b>16030</b>	<b>- Assistant Superintendent</b>	266,007	287,879
Provides the funding to operate the office of the Assistant Superintendent of Schools to support the development, operation and evaluation of the district's elementary and secondary instructional programs.			
This budget unit consists of salaries and benefits for <a href="#">1.50</a> FTEs.			
<b>16040</b>	<b>- Human Resources</b>	790,590	835,384
Provides the funding to support operation of the Human Resources office including advertising, recruiting, hiring, staff development, legal fees, software applications, and compliance requirements.			
This budget unit consists of salaries and benefits for <a href="#">5.00</a> FTEs.			

## **2018 Revised Budget by Budget Unit**

<b>16041</b>	<b>- Workers Comp, Unemployment, &amp; Premiums for Property Casualty Liability Insurance</b>	1,100,000	1,065,000
Provides the funding to support the District's workers comp, unemployment, and property, casualty liability insurance and contingencies for deductibles.			
This budget unit consists of salaries and benefits for <a href="#">no</a> FTEs.			
<b>16050</b>	<b>- Business</b>	1,245,944	1,234,986
Provides the funding to operate the school district's business services- including accounting, payroll, and mandatory state and federal reporting.			
This budget unit consists of salaries and benefits for <a href="#">10.50</a> FTEs.			
<b>16054</b>	<b>- Business - OPEB Implicit Chargeback</b>	-455,751	-455,751
Represents allowable medical, dental, and life insurance costs reimbursable by the district's other postemployment benefits trust.			
This budget unit consists of salaries and benefits for <a href="#">no</a> FTEs.			
<b>16060</b>	<b>- Communications and Marketing</b>	489,852	489,752
Provides the funding to the District's communications and marketing initiatives, maintenance of District websites, social networks, publications, etc.			
This budget unit consists of salaries and benefits for <a href="#">2.00</a> FTEs.			
<b>16070</b>	<b>- Student Registration and Census</b>	570,158	572,308
Provides the funding to operate the school district's student registration, enrollment, and reporting services.			
This budget unit consists of salaries and benefits for <a href="#">6.50</a> FTEs.			
<b>17010</b>	<b>- Voluntary Pre-Kindergarten</b>	569,395	881,172
Provides the funding to operate the Voluntary Pre-Kindergarten Program.			
This budget unit consists of salaries and benefits for <a href="#">4.13</a> FTEs.			
<b>17011</b>	<b>- Elementary Administrators</b>	1,731,654	1,757,449
Provides the funding to operate the elementary principals' offices at each school.			
This budget unit consists of salaries and benefits for <a href="#">10.00</a> FTEs.			
<b>17012</b>	<b>- Elementary Building Clerical</b>	741,484	757,796
Provides the funding to operate the elementary principals' offices at each school.			
This budget unit consists of salaries and benefits for <a href="#">11.50</a> FTEs.			

## **2018 Revised Budget by Budget Unit**

<b>17013</b>	<b>- Elementary EAs</b>	357,493	296,307
Provides the funding various administrative and educational roles at each school.			
This budget unit consists of salaries and benefits for <a href="#">14.38</a> FTEs.			
<b>17021</b>	<b>- Secondary Administrators</b>	1,833,012	1,787,581
Provides the funding to operate the secondary principals' offices at each school.			
This budget unit consists of salaries and benefits for <a href="#">10.00</a> FTEs.			
<b>17022</b>	<b>- Secondary Building Clerical</b>	1,144,581	1,179,477
Provides the funding to operate the secondary principals' offices at each school.			
This budget unit consists of salaries and benefits for <a href="#">18.62</a> FTEs.			
<b>17023</b>	<b>- Secondary EAs</b>	380,111	331,063
Provides the funding various administrative and educational roles at each school.			
This budget unit consists of salaries and benefits for <a href="#">6.62</a> FTEs.			
<b>17025</b>	<b>- Miscellaneous Stipends</b>	144,907	147,074
Provides the funding for miscellaneous stipends and extra hours that are currently not attached to another budget unit.			
This budget unit consists of salaries and benefits for <a href="#">no</a> FTEs.			
<b>18010</b>	<b>- Student Transportation</b>	3,722,314	3,709,982
Provides the funding to transport eligible students to and from school including during regular and extended year/day terms.			
This budget unit consists of salaries and benefits for <a href="#">3.62</a> FTEs.			
<b>19010</b>	<b>- Custodial</b>	5,437,243	5,531,442
Provides the funding to operate the District's custodial services. Includes supplies, equipment and contracted services.			
This budget unit consists of salaries and benefits for <a href="#">73.40</a> FTEs.			
<b>19020</b>	<b>- Building, Grounds and Maintenance</b>	1,631,354	1,686,147
Provides the funding to operate the District's building, grounds and maintenance departments. Includes supplies, equipment and contracted services.			
This budget unit consists of salaries and benefits for <a href="#">8.50</a> FTEs.			
<b>19030</b>	<b>- Environmental Health and Safety/ADA Compliance</b>	1,993,231	1,507,723
Provides the funding to operate the District's environmental health and safety department. Includes supplies, equipment and contracted services.			
This budget unit consists of salaries and benefits for <a href="#">1.60</a> FTEs.			

## **2018 Revised Budget by Budget Unit**

<b>19040</b>	<b>- Facility Leases</b>	579,508	579,508
Provides the funding for the District's facility leases for BEST, Pates Stadium and the Hamilton Building.			
This budget unit consists of salaries and benefits for <a href="#">no</a> FTEs.			
<b>19041</b>	<b>- Facilities Rental</b>	-	35,000
Provides the funding for the District's facilities and sites that are available for community and public rental.			
This budget unit consists of salaries and benefits for <a href="#">no</a> FTEs.			
<b>19050</b>	<b>- Warehouse and Purchasing</b>	131,040	122,751
Provides the funding to operate the school district's warehouse and purchasing departments.			
This budget unit consists of salaries and benefits for <a href="#">1.50</a> FTEs.			
<b>19060</b>	<b>- Utilities</b>	2,007,089	2,007,089
Provides the funding for the District's utilities.			
This budget unit consists of salaries and benefits for <a href="#">no</a> FTEs.			
<b>20010</b>	<b>- School Resource Officers</b>	270,000	270,000
Provides the primary funding for school police resource officers for the district's secondary schools.			
This budget unit consists of salaries and benefits for <a href="#">no</a> FTEs.			
<b>20030</b>	<b>- Safe Schools</b>	238,233	237,903
Provides the primary funding for additional supervision at Burnsville Senior High and Metcalf Junior High.			
This budget unit consists of salaries and benefits for <a href="#">5.25</a> FTEs.			
<b>21000</b>	<b>- Current Grants</b>	-	272,000
Funding provided as grants through various sources.			
This budget unit consists of salaries and benefits for <a href="#">no</a> FTEs.			
<b>Total General Fund Expenditure Budget</b>		<b>130,598,185.00</b>	<b>130,846,390.00</b>

Total General Fund  
Period FTEs - 1145.07

## 2018 Revised Budget - Staffing by Budget Unit

### Budget Unit: 01010

Description	Location	Employee Name	Seq.	FTE
1ST GRADE TCR	EDWARD NEILL	ALLMAN, KELLIE R	1	1.00
		OLSEN, LAURA	1	1.00
		ROSSINI, CATHERINE L	1	1.00
GIDEON POND	GIDEON POND	GRUENKE, BETH N	1	1.00
		ODEGARD, ELISA	1	1.00
		SELBY, HANNAH	1	1.00
HARRIET BISHOP	HARRIET BISHOP	DAHL, SABRINA LYNN	1	1.00
		DANNER, ANDREA L	1	1.00
		MARSHALL, DEBRA L	1	1.00
		STROWBRIDGE, STACI	1	1.00
HIDDEN VALLEY	HIDDEN VALLEY	BRIGGS, LORI A	1	1.00
		HIEBERT, TRACY	1	1.00
		LANGRECK, LORI	1	1.00
MW SAVAGE	MW SAVAGE	KACHMAN, ANGELA	1	1.00
		SANDS, ANNE	1	1.00
RAHN	RAHN	GAMBUCCI, ANN MARIE	1	1.00
		HOINS, DAWN	1	1.00
		WHITE-JARZYNA, SUSAN L	1	1.00
SIOUX TRAIL	SIOUX TRAIL	KUNKEL, ROBERTA E	1	1.00
		ODEGARD, ELIZABETH A	1	1.00
SKY OAKS	SKY OAKS	KEDING, ANGELICA	1	1.00
		KNUDSEN, JULIE A	1	1.00
		OSTDIEK, TERESA L	1	1.00
		SINGLETON, SARAH K	1	1.00
VISTA VIEW	VISTA VIEW	BELGRAVE, ANGELA I	1	1.00
		IVORY, COURTENEY	1	1.00
WM. BYRNE	WM. BYRNE	ORLANDO, KARI R	1	1.00
		SIMPSON, LISA	1	1.00
		SMITH, MELISSA	1	1.00
<b>1ST GRADE TCR - Total</b>				<b>29.00</b>
2ND GRADE TCR	EDWARD NEILL	BEARTH, LUKE A	1	1.00
		LAMB, CYNTHIA L	1	1.00
		LENTON, TIFFANY	1	1.00
GIDEON POND	GIDEON POND	AMBUEHL, JENNIFER A	1	1.00
		RAU, JESSICA	1	1.00
		STONEKING, STACY	1	1.00
HARRIET BISHOP	HARRIET BISHOP	ENGEN, AMY	1	1.00
		OMODT, JANE	1	1.00
		SCHAFFER, KRISTY J	1	1.00
		SCHMIDT-BOYLES, DAWN	1	1.00
HIDDEN VALLEY	HIDDEN VALLEY	KNUDSEN, EYENIA	1	1.00
		TOLLERUD, TERESA JO	1	1.00
		WALBY, MOLLY E	1	1.00
MW SAVAGE	MW SAVAGE	ELLIOTT, RACHEL R	1	1.00
		JARZYNA-INGLES, ANNE W	1	1.00
		STRAHOTA, SARA J	1	1.00
RAHN	RAHN	MATHYS, SANDRA	1	1.00
		PLUCINAK, JODY L	1	1.00
SIOUX TRAIL	SIOUX TRAIL	OTREMBIA, KAREN ANN HOBERG	1	1.00

## 2018 Revised Budget - Staffing by Budget Unit

		PETERSON, CHRISTINE K	1	1.00
SKY OAKS		MULDER, LINDSEY	1	1.00
		PRUGH PLOEHN, KATHRYN A	1	1.00
		SCHNEIDER, MARISA LYNN MOE	1	1.00
VISTA VIEW		DENNIS, TERESA L	1	1.00
		GANDRUD, JENNIFER L	1	1.00
		STEEG, KIMBERLY KAYE	1	1.00
WM. BYRNE		BIGELOW, DEBRA K	1	1.00
		KRZEWKI, CATHERINE D	1	1.00
		TOMALA, CRYSTAL M	1	1.00
<b>2ND GRADE TCR - Total</b>				<b>29.00</b>
3RD GRADE TCR	EDWARD NEILL	BARTLING, MEGHAN	1	1.00
		ENGDAHL, ANN MARY	1	1.00
		HAYDEN, SUZANNE	1	1.00
GIDEON POND		SKOGLUND, ALLISON L	1	1.00
		TRAETOW, ANDREA	1	1.00
		ZUCOLLO, SUSAN R	1	1.00
HARRIET BISHOP		HABERLACK, CHERYL A	1	1.00
		HUBER, ERIN	1	1.00
		MORLOCK, KATHERINE R	1	1.00
HIDDEN VALLEY		ANDREWS, DONNA	1	1.00
		DWIRE, MELINDA	1	1.00
		SCHLINK, JOANNE	1	1.00
MW SAVAGE		HOLDEN, NICHOLE L	1	1.00
		STOLTZ, LISA A	1	1.00
		WEBSTER, SUSAN M	1	1.00
RAHN		HARTL, ARAN J	1	1.00
		HILL, GARY S	1	1.00
		KOHN, GRACE M	1	1.00
		WENZ, RACHEL M	91	0.00
SIOUX TRAIL		BOCHE, SONIA R	1	1.00
		HORWART, LESLIE	1	1.00
SKY OAKS		GRIFFIN, MICHELE C	1	1.00
		JERMELAND, MEGHAN M	1	1.00
		POLLITT, LINDSEY M	1	1.00
VISTA VIEW		HOUTMAN, JENNIFER L	1	1.00
		KRAMER, KRISTA	1	1.00
		SILVERS, KATHRYN	1	1.00
WM. BYRNE		COOPER, KIRENZA I	1	1.00
		HANSON, DEBRA A	1	1.00
		LAMONT, HEIDI O	1	1.00
<b>3RD GRADE TCR - Total</b>				<b>29.00</b>
4TH GRADE TCR	EDWARD NEILL	CONDON, JAMES F	1	1.00
		HOVLAND, SUSAN C	1	1.00
		PETRELLA, SARA M	1	1.00
GIDEON POND		BEENINGA, JANE	1	1.00
		GALLUS, JEFFREY	1	1.00
		KING, DANIEL AUSTIN	1	1.00
HARRIET BISHOP		BERRYMAN, ASHLEY A	1	1.00
		CORONIS, STACY S	1	1.00
		SORUCO, MARIA R	1	1.00

## 2018 Revised Budget - Staffing by Budget Unit

HIDDEN VALLEY	ANDERSON, KRISTEN L	1	1.00	
	ERTL, ABBY	1	1.00	
	LECOMPTE, EMILIE S	1	1.00	
MW SAVAGE	JENSEN, LETA	1	1.00	
	LORAN, KERIANNE N	1	1.00	
	SAWDEY, MARY E	1	1.00	
RAHN	HILL, KARI L	1	1.00	
	PLEVIAK, MEGAN E	1	1.00	
	TOFTE, ALISSA G	1	1.00	
SIOUX TRAIL	BATTERMAN, JESSICA M	1	1.00	
	MULLIKEN, ASHLEY E	1	1.00	
	RING, KATLIN	1	1.00	
SKY OAKS	GRAVINK, ASHLEY	1	1.00	
	RICHARDS, JESSE	1	1.00	
	SCHILLING, PAM A	1	1.00	
VISTA VIEW	DEMPSEY, JODI JEAN	1	1.00	
	LEE, JENNIFER	1	1.00	
WM. BYRNE	BRAGG, KAITLIN J	1	1.00	
	HANSON, LISA	1	1.00	
	WURDEMAN, DEBRA SUE	1	1.00	
<b>4TH GRADE TCR - Total</b>			<b>29.00</b>	
5TH GRADE TCR	EDWARD NEILL	GILRAY, REBECCA J	1	1.00
		VANTHOURNOUT, JANA	1	1.00
		ZAK, GLORIA	1	1.00
GIDEON POND		KLEVEN, MARK A	1	1.00
		MACNAUGHTON, LAURA	1	1.00
		ROBISON, THOMAS C	1	1.00
HARRIET BISHOP		ANDERSON, MELISSA	1	1.00
		FORSTER, KATHRYN	1	1.00
		MECHAVICH, EMILY A	1	1.00
HIDDEN VALLEY		WALLENTA, PAUL S	1	1.00
		KOHNER, JOSEPH E	1	1.00
		SCHWENN, JEFFREY A	1	1.00
MW SAVAGE		WILLS, ALEXANDRIA	1	1.00
		HIEB, MEGAN L	1	1.00
		WARMKA, CHERI R	1	1.00
RAHN		ZUPKE, SAMUEL	1	1.00
		MONSON, COREY E	1	1.00
		SLATTERY, CARA	1	1.00
SIOUX TRAIL		BIRCH, NANCY A	1	1.00
		TOMPACH, TRACY J	1	1.00
SKY OAKS		BERG, MATTHEW T	1	1.00
		BRYANT, MELANIE A	1	1.00
		TAYLOR, DAVID	1	1.00
VISTA VIEW		BLACKMAN, LAURA	1	1.00
		WEST, JULIE MARGARET WARD	1	1.00
WM. BYRNE		ELSAGHER, SARAH C	1	1.00
		GANT, SARAH M	1	1.00
		GIERADA, BARBARA L	1	1.00
		HAPPE, NICOLE	1	1.00
<b>5TH GRADE TCR - Total</b>			<b>29.00</b>	

## 2018 Revised Budget - Staffing by Budget Unit

KINDERGARTEN TCR	EDWARD NEILL	BARNABY, BRIONNA	1	1.00
		LIPPKA, JONALYN	1	1.00
		PRAYFROCK, JUDIE A	1	1.00
GIDEON POND		BRACE, ROXANNA N	1	1.00
		MERKLING, ANGELA MARTIN	1	1.00
		NIELSEN, BRITTNEY	1	1.00
		TREKELL, TERESE	1	1.00
HARRIET BISHOP		HARROLD, STACEY L	1	1.00
		MEYER, TANYA L	1	1.00
		PAVEK, BROOKE C	1	1.00
HIDDEN VALLEY		FINCH, CHRISTINE M	1	1.00
		MCCROSKEY, SHARI	1	1.00
		ULRICH, JULIA	1	1.00
MW SAVAGE		BUSSE, CYNTHIA	1	1.00
		PRESTON, ANGELA	1	1.00
		WINTERLIN, SARAH C	1	1.00
RAHN		MCCARTHY, JENNIFER	1	1.00
		RICHARDSON, SARAH	1	1.00
SIOUX TRAIL		HAGEN, AIMEE E	1	1.00
		PEDERSON, ELIZABETH M	1	1.00
SKY OAKS		NICHOLSON, MARCIA L	1	1.00
		PUTMAN, TANJA	1	1.00
		RITCHIE, JACKI RAE	1	1.00
VISTA VIEW		RHINEVAULT, LYNN	1	1.00
		TUCCI, AMY J	1	1.00
		ZIMMERMAN, KARA J	1	1.00
WM. BYRNE		CALNON, JENNIFER	1	1.00
		HANSEN, MAYA	1	1.00
		HANSMANN, PATRICIA I	1	1.00

<b>KINDERGARTEN TCR - Total</b>	<b>29.00</b>
---------------------------------	--------------

<b>01010 - Total</b>	<b>174.00</b>
----------------------	---------------

### Budget Unit: 02010

Description	Location	Employee Name	Seq.	FTE
6TH GRADE TCR	EAGLE RIDGE	DAY, MARLYS L	1	0.66
		KRAFT, STEPHEN	1	0.83
		MOSEY, PATRICIA	1	0.83
		O'REILLY, GINA	1	0.83
		PELTIER, BRAD W	1	0.83
		SCHROEDER, PATRICIA	1	0.83
		METCALF	BARTON, DUANE	1
		CORONIS, ANTHONY L	1	0.83
		ILES, CORNELIA	1	0.83
		KHAMRATTHANOME, BOUNTHAVY	1	0.83
		KRUPKE, GRETA	1	0.83
		LUNDAHL, TIMOTHY	1	0.83
		MIKELSON, TERESA	1	0.81
		PLANTE, MARY TRACEY	1	0.83
	NICOLLET	DRAYTON, MARGOT ELIZABETH	1	1.00
		GLAS, JOHN M	1	1.00
			11	0.07
		NEMETZ, J SCOTT	1	0.51

## 2018 Revised Budget - Staffing by Budget Unit

		O'REILLY, JOHN T	1	1.00
		SMALLEY, AMY C	1	0.61
<b>6TH GRADE TCR - Total</b>				<b>15.61</b>
AVID TCR	NICOLLET	OLSON, AMY	2	0.20
<b>AVID TCR - Total</b>				<b>0.20</b>
LANG ARTS TCR	EAGLE RIDGE	BLAIR, MICHAEL E.	1	0.34
		DECKER, KATHRYN N	1	0.66
			11	0.07
		ELWARD, LUCIUS P	1	0.66
		FLYNN, CATHERINE T	1	1.00
		PARKINSON, JACQUELYN R	1	0.34
		WALKER, ETHAN D	1	0.66
			11	0.07
		YOUNG, ABBY	1	0.83
	METCALF	HANSEN, WILLIAM C	1	0.83
		NASH, STEPHANIE	1	0.83
		ORTH, STEVEN D. R.	1	0.83
		PAUL, MADISON P	1	0.83
		SCHNOBRICH, ANGELA M	1	0.49
		THOMAS, JESSICA	1	0.56
			11	0.07
	NICOLLET	CHRISTENSEN, KELSEY A	2	0.49
		KELLEHER, SARAH	2	0.29
		MCKENZIE, VICTORIA L	1	1.00
		NEMETH, HEATHER	1	0.51
		ROBB, EMILY C	12	0.20
		SCHMIDT, JENNIFER R	1	1.00
		SORENSEN, BRAD	2	0.49
<b>LANG ARTS TCR - Total</b>				<b>13.04</b>
MATH TCR	EAGLE RIDGE	CZAPAR, RYAN J	1	0.83
			11	0.07
		HAGEN, ALISON M	1	0.66
		NELSON, MICHELLE L	1	0.66
		SLETTEN, ELIZABETH M	1	0.66
		WYSOCKI, STEVEN J	1	0.66
	METCALF	BENSON, ROSS S	1	0.66
		GEDDES, RICHARD W	1	0.66
		LOTZE, TIMOTHY	1	0.66
		MUELLER, SARAH K	1	0.66
	NICOLLET	AMUNDSON, JANE E	1	0.60
		FUNCHES, MONIQUE ROY	1	0.83
		GRUENEICH, JANELLE	1	0.83
		NYSTROM, ROBERT J	1	0.83
<b>MATH TCR - Total</b>				<b>9.27</b>
SCIENCE TCR	EAGLE RIDGE	HAMMER, JEFFREY	1	1.00
			11	0.07
		PALESCH, KAYCIE R	1	1.00
		RAMBOW, CHASE R	1	0.83
		SHANNON WARNER, LINDI B	1	0.83
	METCALF	JOHNSON, CORY CHARLES	1	0.83
			11	0.07

## 2018 Revised Budget - Staffing by Budget Unit

		MEYER, CHAD	1	0.82
		WICKENHAUSER, KIERSTEN L	1	0.83
	NICOLLET	PETTINELLI, STEPHEN M	1	0.50
			11	0.06
		PIEPER, JILL	1	1.00
		SODERHOLM, WM ERIC	1	1.00
		VAN HOORN, KIRSTEN	1	1.00
<b>SCIENCE TCR - Total</b>				<b>9.83</b>
SOC STU TCR	EAGLE RIDGE	ALLEN, TRUDY L	1	0.83
		KLUBBERUD, MICHAEL	1	0.74
		SIMMONS, SEAN D	1	0.83
		YAGER, AMY LYN	2	0.17
	METCALF	BODELSON, ALLEN	1	1.00
		JEFFERS, LUCRETIA	1	0.83
		LUND, KAJ	1	0.83
	NICOLLET	ELFERING, JEAN	1	0.83
		IVERSON, ADAM	1	0.83
		SCHWEIM, ROBERT W	1	0.83
<b>SOC STU TCR - Total</b>				<b>7.72</b>
WORLD LANG TCR	EAGLE RIDGE	LAHR, JOE LYNN	2	0.40
	METCALF	SCHNOBRICH, ANGELA M	2	0.34
	NICOLLET	ANDERSON, JANELLE D	1	0.32
<b>WORLD LANG TCR - Total</b>				<b>1.06</b>
<b>02010 - Total</b>				<b>56.72</b>

### Budget Unit: 03010

Description	Location	Employee Name	Seq.	FTE
AVID TCR	BHS	CHRISTY SIGSTAD, DANIELLE H	2	0.20
		DAVIDSON, ELIZABETH A	2	0.20
		FLUG, JOSHUA W	2	0.20
		GOMER, JENNA M	2	0.20
		HANSEN, MARIE C	2	0.20
		MOFFITT, LESLIE ALLAN	2	0.20
		MOULSOFF, NORINE L	3	0.30
		WALLER MCDEVITT, JENNIFER	2	0.20
<b>AVID TCR - Total</b>				<b>1.70</b>
BEA PRESIDENT	DIAMONDHEAD	WUENSCH, WENDY DRUGGE	1	1.00
<b>BEA PRESIDENT - Total</b>				<b>1.00</b>
DANCE	BHS	WALLER MCDEVITT, JENNIFER	3	0.20
<b>DANCE - Total</b>				<b>0.20</b>
HEALTH CARE TCR	BHS	WERNER-DEMPESEY, ANNE	1	0.60
<b>HEALTH CARE TCR - Total</b>				<b>0.60</b>
LANG ARTS TCR	BHS	BURKE, KATIE J	1	1.00
		BURNHAM, CHARLES F	1	1.00
		CHRISTY SIGSTAD, DANIELLE H	1	0.80
		CONNELL, PAUL J	1	1.00
		DEUTSCH, MATTHEW R	1	0.40
		DYRHAUG, MICHELLE	1	1.00
		EGGERS, SHEANA	1	1.00
		FOLDENAU, HOLLY A	1	1.00
		HANSEN, MARIE C	1	0.80
		MILLEA, ALLISON B	1	1.00

## 2018 Revised Budget - Staffing by Budget Unit

		OHAMA, HAYLEY C	1	0.70
		RUDOLPH, ROXANNE J	1	1.00
		SCHMEICHEL, MATTHEW T	1	1.00
		STAUM, ANNE C	1	1.00
		STEAD, AMY JO	1	1.00
		WALLER MCDEVITT, JENNIFER	1	0.60
		WEBBER, GLORIA M	1	1.00
<b>LANG ARTS TCR - Total</b>				<b>15.30</b>
MATH TCR	BHS	BANITT, JUSTIN	1	0.60
		CHRISTIAN, DAVID	1	1.00
		CROATT, CHARLES C	1	1.00
		DELMONT, BROOKE	1	1.00
		FEIG, PETER E	1	1.00
		FLOYD, KEVIN S	1	0.60
		GEHRKE, ANDREW R	2	0.50
		GOMER, JENNA M	1	0.80
		HARROD, KIMBERLEE N	1	0.40
		KUZIEJ, JANET L	1	1.00
		MEUSER, TERESA	1	1.00
		NELSON, AMY MAI-LEE	1	1.00
		NELSON, JEFFREY P	1	0.60
		NOSS, JEAN	1	1.00
		QUAMME, DAVID R	1	1.00
		SCHLAGER, DEREK A	1	0.60
		STERN, GRETTEL	1	1.00
		VOGT, KENDRA M	1	0.40
<b>MATH TCR - Total</b>				<b>14.50</b>
SCIENCE TCR	BHS	AAMODT, WILLIAM P	1	0.80
		BANE, DEANNA S	1	1.00
		BLANDIN, MELISSA	1	1.00
		DAVIDSON, ELIZABETH A	1	0.80
		DOUGLAS, LORI	1	1.00
		GEHRKE, ANDREW R	1	0.50
		GORES, CHERYL L	1	1.00
		HOESCHEN, KERRY	1	1.00
		HOLT, CLAYTON B	1	1.00
		HUBER, JON ALAN	1	1.00
		HUEMOELLER, MICHAEL T	1	1.00
		HUTCHINSON, JENNIFER L	1	1.00
		MORGAN, WILLIAM E	1	1.00
		PETTINELLI, STEPHEN M	2	0.50
		SCHERRER, HUEL C	1	1.00
		WEIGHTMAN, ELIZABETH C	1	1.00
		WERNER-DEMPSEY, ANNE	2	0.20
<b>SCIENCE TCR - Total</b>				<b>14.80</b>
SOC STU TCR	BHS	AARS, KRISTINA	1	1.00
		BOUSU, MOLLIE J	1	1.00
		CLEVELAND, GEOFFREY W	1	1.00
		COLEMAN, COLLEEN M	1	1.00
		ENGELHARDT, WILLIAM T	1	1.00
		EPPEN, MATTHEW W	1	1.00

## 2018 Revised Budget - Staffing by Budget Unit

		FLUG, JOSHUA W	1	0.80
		FRANSSEN, MICHAEL S	1	1.00
		GRAFF, JENNIFER	1	0.50
		JENSEN, JENNIFER	1	1.00
		MCDEVITT, PAUL DAVID	1	1.00
		MILINOVICH, CHRIS M	1	1.00
		MOFFITT, LESLIE ALLAN	1	0.80
		SILBERMAN, KEVIN	1	1.00
		STRAND, NATHAN R	1	1.00
		VAN SCHOONHOVEN, KATHERINE	1	1.00
		WENDLING, KATHRYN	1	1.00
<b>SOC STU TCR - Total</b>				<b>16.10</b>
WORLD LANG TCR	BHS	ANDERSON, JANELLE D	2	0.40
		BARRY, AMBER LEIGH	1	1.00
		BLAZQUEZ, JAVIER	1	1.00
		DUNDON, MARY LOU	1	1.00
		HOLCOMBE, SARA J	2	0.60
		JENSEN, AMANDA LYNN	1	1.00
		LAHR, JOELYNN	1	0.60
		LARSON, KATIE	1	1.00
		LEHNER, TIMOTHY	1	1.00
		SAUERMANN-PAGE, KARIN G	1	1.00
<b>WORLD LANG TCR - Total</b>				<b>8.60</b>
<b>03010 - Total</b>				<b>72.80</b>

### Budget Unit: 04010

Description	Location	Employee Name	Seq.	FTE	
ART TCR	BHS	PERRY, BRIAN	1	1.00	
		QUIRK, KATHLEEN	1	1.00	
		TOUSIGNANT, ROBYN E	1	0.60	
	EAGLE RIDGE		WEILANDGRUBER, ELIZABETH	1	1.00
	EDWARD NEILL		KNOTT, KELLY S	2	0.50
			SCHRIVER, MARA C	2	0.25
	GIDEON POND		SCHRIVER, MARA C	1	0.75
	HARRIET BISHOP		PETRI, KATHRYN E	1	1.00
	HIDDEN VALLEY		MERKEL, SARA A	1	0.88
	METCALF		PLUEGER, AIMEE F	1	1.00
	MW SAVAGE		KNOTT, KELLY S	1	0.50
			VO, KELLY RAE	2	0.25
	NICOLLET		WILSON, KACIE L	1	1.00
	RAHN		DEROUIN, JILL	2	0.25
			STRANO, ANDREW	2	0.25
	SIOUX TRAIL		DEROUIN, JILL	1	0.75
	SKY OAKS		GREAMBA, ANDREA	1	1.00
	VISTA VIEW		VO, KELLY RAE	1	0.75
	WM. BYRNE		MERKEL, SARA A	2	0.13
			STRANO, ANDREW	1	0.75
<b>ART TCR - Total</b>				<b>13.60</b>	
BAND TCR	BHS	FRENCH, KEITH J	1	1.00	
		HOLMES, MOLLY	1	1.00	
	EAGLE RIDGE		ARMSTRONG, NICHOLAS G	2	0.50
	EDWARD NEILL		KOSLOSKI, SCOTT	2	0.25

## 2018 Revised Budget - Staffing by Budget Unit

	GIDEON POND	NORDMARK, PAMELA J	4	0.25
	HARRIET BISHOP	NORDMARK, PAMELA J	1	0.25
	HIDDEN VALLEY	NORDMARK, PAMELA J	2	0.25
	METCALF	SYLVESTER, GREGORY	2	0.33
	MW SAVAGE	NORDMARK, PAMELA J	3	0.25
	NICOLLET	BAKKEN, ANN	1	0.47
	RAHN	LANGSJOEN, SONJA	3	0.25
	SIOUX TRAIL	LANGSJOEN, SONJA	4	0.25
	SKY OAKS	LANGSJOEN, SONJA	2	0.25
	VISTA VIEW	KOSLOSKI, SCOTT	3	0.25
	WM. BYRNE	LANGSJOEN, SONJA	1	0.25
<b>BAND TCR - Total</b>				<b>5.80</b>
MUSIC TCR	EDWARD NEILL	TRANBY, BONITA K.	1	0.75
	GIDEON POND	BUCK, REBECCA L	2	0.50
		KANNE, VICKI ANN	3	0.13
		TRANBY, BONITA K.	2	0.25
	HARRIET BISHOP	HUISMAN, MITCHELL	1	1.00
		PERRY, JESSICA A	91	0.00
	HIDDEN VALLEY	LUCIUS, RACHEL H	3	0.13
		WOOD, KIMBERLY R	1	0.75
	MW SAVAGE	BUCK, REBECCA L	1	0.50
		WOOD, KIMBERLY R	2	0.25
	RAHN	LUCIUS, RACHEL H	1	0.63
	SIOUX TRAIL	GEESMAN, GARRETT D	1	0.75
	SKY OAKS	SHOOK, JOANN	1	0.88
	VISTA VIEW	GEESMAN, GARRETT D	2	0.25
		KANNE, VICKI ANN	2	0.13
		LUCIUS, RACHEL H	2	0.25
	WM. BYRNE	KANNE, VICKI ANN	1	0.75
		SHOOK, JOANN	2	0.13
<b>MUSIC TCR - Total</b>				<b>8.00</b>
PHY ED TCR	BHS	BROWN, CHRISTOPHER M	2	0.60
		REUSS, ERIC	1	1.00
		RIGGS, MARK D	1	1.00
		STACHOWSKI, SUSAN C	1	1.00
		VAN DER WOUDE, LORALIE A	1	1.00
		VAN DER WOUDE, MARK B	1	1.00
		VARPNESS, VINCENT C	1	1.00
		EAGLE RIDGE	BROWN, CHRISTOPHER M	1
	HERMES, SHELLEY		1	1.00
	PEARSON, CHAD W		1	1.00
	EDWARD NEILL	DUNGEY, NATHAN	2	0.25
		MCKANE, MICHELLE M	2	0.25
		MOORLACH, BRIAN	2	0.25
	GIDEON POND	DUNGEY, NATHAN	1	0.75
		MOORLACH, BRIAN	3	0.13
	HARRIET BISHOP	LOESCH, JAKE	1	1.00
	HIDDEN VALLEY	SHELDEN, JON	1	0.88
	METCALF	FRITZ, KIMBERLY A	1	1.00
		MAYASICH, JENNIFER J	1	0.34
		SCHOLL, WAYNE	1	1.00

## 2018 Revised Budget - Staffing by Budget Unit

MW SAVAGE		MCKANE, MICHELLE M	1	0.75
NICOLLET		ANDREWS, BRIDGETTE	1	0.68
		KALINA, KYLE	1	1.00
			11	0.07
		STRADER, ANN E	1	0.51
			91	0.00
RAHN		JOHNSON, RONNA E	2	0.25
		SWEENEY, MICHAEL J	2	0.25
SIOUX TRAIL		SWEENEY, MICHAEL J	1	0.75
SKY OAKS		CEOLA, MICHAEL	1	1.00
VISTA VIEW		MOORLACH, BRIAN	1	0.63
WM. BYRNE		JOHNSON, RONNA E	1	0.75
		SHELDEN, JON	2	0.13
<b>PHY ED TCR - Total</b>				<b>21.60</b>
STRINGS TCR	BHS	BERENS, MICHELE E	1	0.40
			11	0.04
			KOSLOSKI, SCOTT	1
	EAGLE RIDGE	ARMSTRONG, NICHOLAS G	1	0.50
			BERENS, MICHELE E	3
	HARRIET BISHOP	ANDERSON, EMILY E	1	0.50
	METCALF	SYLVESTER, GREGORY	1	0.67
	NICOLLET	BAKKEN, ANN	3	0.03
		MEYER, ANDREW	1	0.83
	RAHN	ANDERSON, EMILY E	2	0.50
<b>STRINGS TCR - Total</b>				<b>4.04</b>
VOCAL TCR	BHS	ANDERSON, JACLYN C	1	1.00
		SCHMIDT, MARTHA H	1	1.00
	EAGLE RIDGE	BERENS, MICHELE E	2	0.43
	METCALF	KASO, ANGELA M	1	0.83
	NICOLLET	BAKKEN, ANN	2	0.50
<b>VOCAL TCR - Total</b>				<b>3.76</b>
<b>04010 - Total</b>				<b>56.79</b>
<b>Budget Unit: 06010</b>				
Description	Location	Employee Name	Seq.	FTE
FACS TCR	BHS	ASFELD, BETH M	1	1.00
		DEUTSCH, MATTHEW R	2	0.40
			3	0.20
		EICHTEN, HEIDI J	1	1.00
		SCHRAM, SARAH E	1	1.00
		THOM, MARLYS	1	0.40
		91	0.00	
	EAGLE RIDGE	BORDEN, PAIGE M	1	1.00
METCALF	RUZICHKA, LAURIE J	1	1.00	
NICOLLET	RUFF, HAILEY C	1	1.00	
<b>FACS TCR - Total</b>				<b>7.00</b>
PLTW	METCALF	MALLINGER, MELINDA	1	0.83
<b>PLTW - Total</b>				<b>0.83</b>
<b>06010 - Total</b>				<b>7.83</b>
<b>Budget Unit: 06020</b>				
Description	Location	Employee Name	Seq.	FTE
IND TECH TCR	BHS	BRADY, STEVE	2	0.30

## 2018 Revised Budget - Staffing by Budget Unit

		JONES, JACQUELINE A	1	1.00
		PATRIE, ORION D	1	1.00
		TESMER, RUSSELL	1	1.00
		WOLF, NICHOLAS	1	1.00
EAGLE RIDGE		BRADY, STEVE	1	0.70
			11	0.10
NICOLLET		PAETZOLD, ROBERT JAMES	1	1.00

**IND TECH TCR - Total** **6.10**

**06020 - Total** **6.10**

### **Budget Unit: 06040**

Description	Location	Employee Name	Seq.	FTE
BUSINESS TCR	BHS	CARROLL, MICHELE	1	1.00
		DRAHOS, CYNTHIA	1	1.00
		HUBBARD, MARK R	1	0.80
		MALONE, MEGGAN J	1	1.00
	EAGLE RIDGE	SAYERS, KEVIN	1	1.00
	METCALF	TWEDTEN, SARA	1	1.00

**BUSINESS TCR - Total** **5.80**

**06040 - Total** **5.80**

### **Budget Unit: 06050**

Description	Location	Employee Name	Seq.	FTE
PATHWAYS	DIAMONDHEAD	FUNSTON, KATHY	1	1.00
		JACOBS, MICHELLE	1	0.75

**PATHWAYS - Total** **1.75**

### **Budget Unit: 07010**

Description	Location	Employee Name	Seq.	FTE
COLLEGE & CAREER SPECIALIST	BHS	SEXTON, MARCIA	1	1.00

**COLLEGE & CAREER SPECIALIST - Total** **1.00**

EA MEDIA	BHS	LAKE, LISA L	1	1.00
	EDWARD NEILL	MILLER, KATHERINE C	1	0.75
	GIDEON POND	BUTORAC, MELANIE A	1	0.75
	HARRIET BISHOP	BECKER, SARAH J	1	0.75
	HIDDEN VALLEY	SCHATZLEIN, RACHEL	1	0.75
	MW SAVAGE	SCHEUNEMAN, KRISTEN JOY	1	0.75
	RAHN	GOOD, DONNA A	1	0.75
	SIOUX TRAIL	ENGBERG, DENISE G	1	0.75
	SKY OAKS	BERGE, KRISTY K	1	0.75
	VISTA VIEW	CERMAK, BARBARA L	1	0.75
	WM. BYRNE	HORTON, SHEILA M	1	0.75

**EA MEDIA - Total** **8.50**

MEDIA SPECIALIST	BHS	OIE, ROGER	1	1.00
	EAGLE RIDGE	GALLAND, JOHN	1	1.00
	METCALF	GRIFFITHS, ROBERT H	1	1.00
	NICOLLET	MEYER, NANCY L	1	1.00

**MEDIA SPECIALIST - Total** **4.00**

**07010 - Total** **13.50**

### **Budget Unit: 07020**

Description	Location	Employee Name	Seq.	FTE
GIFTED/ENRICH TCR	EDWARD NEILL	NIFFENEGGER, KAMALA N	1	0.50
	GIDEON POND	MIRS, LAUREL	1	0.50

## 2018 Revised Budget - Staffing by Budget Unit

HARRIET BISHOP	CAMPEN, KIMBERLY A.	1	1.00
	NAEF, NATHAN A	1	0.50
HIDDEN VALLEY	NAEF, NATHAN A	2	0.50
MW SAVAGE	LINDELL, MICHELLE M	1	0.50
RAHN	PETERSON, KERI	1	0.30
SIOUX TRAIL	STALOCK, SHARRON C	2	0.50
SKY OAKS	TEIEN, JOAN K	2	0.50
VISTA VIEW	PODRATZ, ANNE MARIE	1	0.50
WM. BYRNE	CHAMERLIK, KAREN	2	0.50

**GIFTED/ENRICH TCR - Total** **5.80**

**07020 - Total** **5.80**

### Budget Unit: 07030

Description	Location	Employee Name	Seq.	FTE
CAREER FAIR COORDINATOR	BHS	SWANSON, MARGO	32	0.00

**CAREER FAIR COORDINATOR - Total** **0.00**

COUNSELOR	BHS	AKERSON, REBECCA D	1	1.00	
		CRAIG, SARA J	1	1.00	
		HENDRICKS, SCHERESS	1	1.00	
		LIMKE, JEFFREY	1	1.00	
		MARKHAM, ANGELA L	1	0.70	
		MARSHALL, VERONICA JEAN	1	1.00	
		WELKE, ASHLEY L	1	1.00	
	EAGLE RIDGE	HARRISON, P SCOTT	1	1.00	
		HENDERSON, MICHELLE A	1	1.00	
	METCALF	MAIDMENT, LORI	1	1.00	
		SODERHOLM, JOHN	1	1.00	
	NICOLLET	BRETT, CARRIE A	1	0.20	
		KELSON, FREDERICK A	1	1.00	
		ROBB, EMILY C	1	0.40	
				11	0.40
	ST JOHNS	MARKHAM, ANGELA L	2	0.30	

**COUNSELOR - Total** **13.00**

**07030 - Total** **13.00**

### Budget Unit: 07040

Description	Location	Employee Name	Seq.	FTE
DEAN	BHS	MEYER, JOSEPH	1	1.00
			16	0.00
		MULLINS, CYNTHIA	1	1.00
			16	0.00
		OSMAN, AKRAM	1	1.00
			16	0.00
	EAGLE RIDGE	RIESGRAF, LUCAS D	1	1.00
			16	0.00
	METCALF	NOBLE, SARAH J	1	1.00
			16	0.00
	NICOLLET	TIMMER, ANDREW J	1	1.00
			16	0.00

**DEAN - Total** **6.00**

**07040 - Total** **6.00**

### Budget Unit: 07060

Description	Location	Employee Name	Seq.	FTE
-------------	----------	---------------	------	-----

## 2018 Revised Budget - Staffing by Budget Unit

ESL TCR	ALTERNATIVE HIGH SCHOOL	BRAUN, JEAN C	1	0.50
		DURAND, KIM	1	1.00
	BHS	AMARREH, HAMIDA I	1	1.00
		CARLSON, CATHERINE M	1	1.00
		MOREN, KIMBERLY J	1	1.00
		PARENT, ANDREA J	1	1.00
		PERSONS, MELISSA B	1	1.00
		WINTERLIN, JEFFREY	1	1.00
	EAGLE RIDGE	BLAIR, FRANCES M.	1	1.00
		GREGORY, AMANDA	1	1.00
	EDWARD NEILL	DALY, JULIE	1	1.00
		GONZALEZ, MEGAN	1	0.50
		MUSA-AGBONENI, KARI	1	1.00
	GIDEON POND	CORROW, JENNA R	1	1.00
		COWELL-HASKIN, ASHLEY	1	1.00
		KING, KRISTEN A	1	1.00
	HARRIET BISHOP	MCKINNEY, MARGARET	1	1.00
		PHILLIPS, MARIA	1	1.00
	HIDDEN VALLEY	BLOM, ANNE E	1	1.00
		CADWELL, ANN M	1	1.00
		CULLISON, CAROLINE E	1	1.00
		MICHELS, CHRISTINE	1	1.00
		O'BRIEN, BRIANNA	1	1.00
		PROCTOR, BETH	1	1.00
	METCALF	BRAUN, JEAN C	2	0.50
		FRIENDT, ANDREA LYNN	1	1.00
		KESSLER, CECILIA	1	1.00
	MW SAVAGE	ANDERSON, ALYSSA KAE	1	1.00
		BENSON, BRIANA M	1	1.00
	NICOLLET	LIMBERG, MINDI L	1	0.50
		OLSON, AMY	1	0.80
		WEISBOND, JONAH	1	1.00
	RAHN	ARIAS, ANGELA JOY	1	1.00
		OLSON, KIMBERLY LENORA	1	1.00
	SIOUX TRAIL	FREDRICKSON, REBECCA	1	1.00
	SKY OAKS	ECKERMAN, HANNAH	1	1.00
		HENNEN, JENNIFER S	1	1.00
		JONES, NOELLE	1	1.00
		RIPHENBURG, WENDY A	1	1.00
	VISTA VIEW	CARLSON, LISA M	1	1.00
		GONZALEZ, MEGAN	2	0.50
		THOMPSON, SALOUA	1	1.00
	WM. BYRNE	JOHNSON, ASHLEY MARSHALLA	1	1.00
		LORINCZ, KRISTEN L	1	1.00

<b>ESL TCR - Total</b>	<b>41.30</b>
------------------------	--------------

<b>07060 - Total</b>	<b>41.30</b>
----------------------	--------------

### **Budget Unit: 09010**

Description	Location	Employee Name	Seq.	FTE
ASSISTIVE TECH	DISTRICT-WIDE	ALLEN, SUSAN M	1	0.50
		NELSON, KATIE L	2	0.50
<b>ASSISTIVE TECH - Total</b>				<b>1.00</b>

## 2018 Revised Budget - Staffing by Budget Unit

BEHAVIOR SPECIALIST	DISTRICT-WIDE	CZAPAR, KELLY N	1	1.00
		EWERT, CASEY B	1	1.00
<b>BEHAVIOR SPECIALIST - Total</b>				<b>2.00</b>
CLERICAL	ALTERNATIVE HIGH SCHOOL	TANBERG, TERESA L	2	0.10
		BEST	TANBERG, TERESA L	1
	BHS	LABONTE, REBECCA A	1	1.00
		MCCLELLAN, MELISSA E	91	0.00
	DIAMONDHEAD	KAISER, TANYA J	1	0.50
		REISINGER, TONETTE A	1	0.50
			2	0.50
		SIEBER, ANDREA	91	0.00
	EAGLE RIDGE	STRUCK, JULIE	1	1.00
		BARLAGE, SUSAN	1	1.00
	ECSE CENTER	GRIES, BRENDA J	1	1.00
		WILLENBURG, JOANNA	1	0.50
			2	0.50
	METCALF	MOBERG, CARLENE	1	1.00
	NICOLLET	ALEXON, BETH J	1	1.00
	<b>CLERICAL - Total</b>			
CULTURAL LIAISON	ECSE CENTER	HUSSEIN, HAMDY	1	0.88
		RIVEROS, ANNA-MARIA	1	0.50
		2	0.50	
<b>CULTURAL LIAISON - Total</b>				<b>1.88</b>
DAPE	DISTRICT-WIDE	HOLDEN, MATTHEW J	1	1.00
		OPATZ, LARRY	1	1.00
<b>DAPE - Total</b>				<b>2.00</b>
DIR OF SPECIAL ED	DIAMONDHEAD	CORBEY, STEPHANIE A	91	0.00
			92	0.00
		WHITE, STEPHANIE C	1	0.50
			2	0.50
<b>DIR OF SPECIAL ED - Total</b>				<b>1.00</b>
EA HEALTH	DISTRICT-WIDE	GADDY, KESHIA	1	0.73
		HANSEN, SARAH J	1	0.91
		LUTH, DONITA	1	0.91
		SPENCE, LORETTA	1	0.73
		STENE, BARBARA	1	0.73
		WITTENKELLER, JANE E	2	0.08
<b>EA HEALTH - Total</b>				<b>4.07</b>
ECSE TCR	ECSE CENTER	ALBERSHEIM-CARTER, MARCINA	1	1.00
		BLOMQUIST, STEPHANIE	1	1.00
		BLOOD, KELSEY JO	1	1.00
		CLOUTIER, DANA M	1	0.50
			2	0.50
		EBENHOH, TEEGAN M	1	1.00
		ERBES, SARAH L	1	0.50
		HIMRICH, JOANNE	1	1.00
		JORGENSEN, SHANNON E	1	0.80
		MELQUIST, MICHELLE	1	1.00
		NELSON, KATHERINE	1	1.00
		NELSON, TARA A	1	0.50
		NESS, KAREN M	1	1.00

## 2018 Revised Budget - Staffing by Budget Unit

		NIEMIEC, ALICIA	1	1.00
		ORLICH-SULLIVAN, MEGAN	1	1.00
		OSTMAN, LAUREN O	1	1.00
		PECK, ANNALISE C	1	1.00
		RENKEN, CARISSA M	1	1.00
		SPAULDING, SHEILA J	1	1.00
		STAHLY, JANICE	1	1.00
		THOMPSON, HYE-JEONG M	1	1.00
<b>ECSE TCR - Total</b>				<b>18.80</b>
LTS - ECSE	ECSE CENTER	OSCARSON, KRISTI R	61	0.00
<b>LTS - ECSE - Total</b>				<b>0.00</b>
NURSE	ALTERNATIVE HIGH SCHOOL	COZAD, PATRICIA M	2	0.16
	BEST	MCDERMOTT-BATY, JODY	3	0.20
	BHS	WALCHER, PAMELA J	1	0.53
	EAGLE RIDGE	EILERTSON, JANE ANN	2	0.67
	ECSE CENTER	HENKE, LORI A	1	0.87
	EDWARD NEILL	MCDERMOTT-BATY, JODY	2	0.22
	GIDEON POND	BAGGOT, LYNN	4	0.06
	HARRIET BISHOP	BAGGOT, LYNN	2	0.20
	HIDDEN VALLEY	BIEN, BERNADETTE L	2	0.20
	METCALF	WALDRON, RACHELLE	1	0.59
	MW SAVAGE	BIEN, BERNADETTE L	4	0.19
	NICOLLET	WITTNEBEL, KATHY	2	0.22
	RAHN	LATTERY, CHRISTINE A	1	0.07
	SIOUX TRAIL	BEAULIEU, KOURTNEY A	2	0.36
	SKY OAKS	COZAD, PATRICIA M	3	0.17
	VISTA VIEW	WARDELL, BARBARA J	2	0.04
	WM. BYRNE	LATTERY, CHRISTINE A	4	0.07
<b>NURSE - Total</b>				<b>4.82</b>
NURSE - REGISTERED	DISTRICT-WIDE	HAYES, JENNIFER	2	0.16
		ROBISON, KIMBERLY A	2	0.49
		SHERER, CAROL MARIE	2	0.16
		STINSON, KATRINA L	2	0.18
		WHITE, ERICA E	2	0.19
<b>NURSE - REGISTERED - Total</b>				<b>1.18</b>
OCC THERAPIST	DISTRICT-WIDE	CESARO-MOXLEY, RACHEL L	1	0.40
		CSELOVSZKI, CASSANDRA K	1	0.50
		GOSSMAN, LISA ANN	1	1.00
		KOLSTAD, MICHELE M	1	1.00
	ECSE CENTER	CSELOVSZKI, CASSANDRA K	2	0.50
		MESARCHIK, MARY L	1	1.00
		ROBOLE, VICKI M	1	0.80
			11	0.20
		ROESKE, MELISSA L	1	0.95
	GIDEON POND	ROESKE, MELISSA L	2	0.05
<b>OCC THERAPIST - Total</b>				<b>6.40</b>
PSYCHOLOGIST	ALTERNATIVE HIGH SCHOOL	OTTO, CARON	2	0.30
	BEST	KRAL, MELISSA M	2	0.20
	BHS	ATTANASIO, MEGAN	1	1.00
		KRYLOVA, ANNA V	2	0.20
		NIERENGARTEN, BRIANNA L	1	1.00

## 2018 Revised Budget - Staffing by Budget Unit

EAGLE RIDGE	OTTO, CARON	1	0.70	
ECSE CENTER	KENNEDY, JENNIFER K	1	0.60	
	NANIA, PAULA A	1	1.00	
	PETERSEN, HOLLY M	1	1.00	
EDWARD NEILL	KOMAR, KAREN K	1	0.50	
GIDEON POND	SCHULTZ, HOLLY	1	0.50	
HARRIET BISHOP	LAUTIGAR-BEUTZ, JULIE	2	0.35	
HIDDEN VALLEY	KOMAR, KAREN K	2	0.50	
METCALF	KRAL, MELISSA M	1	0.80	
MW SAVAGE	YOUNG, DANIELLE M	1	0.50	
NICOLLET	KRYLOVA, ANNA V	1	0.80	
RAHN	LAUTIGAR-BEUTZ, JULIE	1	0.35	
SIOUX TRAIL	YOUNG, DANIELLE M	2	0.50	
SKY OAKS	SCHULTZ, HOLLY	2	0.50	
VISTA VIEW	ROEHL, PETER A	1	0.50	
WM. BYRNE	ROEHL, PETER A	2	0.50	
<b>PSYCHOLOGIST - Total</b>			<b>12.30</b>	
READING SPECIALIST	EDWARD NEILL	KUGLER, JULIE	1	1.00
		WAGNER-SMITH, SHERRY	1	1.00
	HIDDEN VALLEY	CHISAKA, BRIDGET N	1	1.00
		COLLINS, LEANNE	1	1.00
		NURMELA, CRYSTAL	1	0.50
	SKY OAKS	CUNNIEN, LAURIE A	1	0.50
		RUHLAND, MARIA	1	1.00
		TEIEN, JOAN K	1	0.50
	VISTA VIEW	CRAWFORD, CINDY Y	1	1.00
		DITMARSEN, SANDRA L	1	1.00
<b>READING SPECIALIST - Total</b>			<b>8.50</b>	
SOCIAL WORKER	ALTERNATIVE HIGH SCHOOL	HEWETT, THOMAS	2	0.10
	BEST	MCLAUGHLIN, ALEXANDRA M	4	0.10
	BHS	HEWETT, THOMAS	1	0.90
	EAGLE RIDGE	MCLAUGHLIN, ALEXANDRA M	2	0.30
	ECSE CENTER	KELLER, KATIE	1	1.00
	METCALF	MCLAUGHLIN, ALEXANDRA M	3	0.30
	NICOLLET	MCLAUGHLIN, ALEXANDRA M	1	0.30
	SIOUX TRAIL	MCDOWELL, MORGAN	1	1.00
<b>SOCIAL WORKER - Total</b>			<b>4.00</b>	
SPED EA	BEST	AHMED KHAN, NAJMA	1	0.88
		ANDERSON, CHERYL L	1	0.88
		FINCH, JEANNE	1	0.88
		FRANK, SHARON M	1	0.88
		GOODLING, BEVERLY	1	0.88
		IVERSON, WILLIAM C	1	0.88
		MEYMAN, WHITNEY	1	0.88
		PAYNE, BARBARA	1	0.88
		TOUSIGNANT, KARE KATHLEEN	1	0.88
		BHS	ADRIAN, JANN L	1
	ANDREASEN, ARNOLD		1	0.88
	BENGTSON, CAROL		1	0.88
	BERG, DAVID A		1	0.88
		CHROUST, VICKI	1	0.88

**2018 Revised Budget - Staffing by Budget Unit**

	DIXON, DAVE T	1	0.88
	ESTEY, KELSEY	91	0.00
	GARVIS, ANGELA N	1	0.88
	GREINER, JODELL	1	0.88
	HOLTAN, HELEN	1	0.88
	KOLUMBUS, RYAN C	1	0.88
	LARSON, JANET ANNE	1	0.88
	LEDIN, CHASE	1	0.88
	LERFALD, JUSTIN	1	0.88
	MARTINSON, JONI	1	0.88
	MCCORMICK, SARA	1	0.88
	MILLER, WHITNEY	91	0.00
	NOWLAN, TRAVIS	1	0.88
	Open Position	0	0.88
	QUEEN, JACQUELYN	91	0.00
	RAY, STEPHEN	1	0.88
	SMIDT, HOLLY B	1	0.88
	THOENNES, SALLY	1	0.88
	TUCKER, CINDY I	91	0.00
	WAGNER, PATRICIA	1	0.88
	WOLFF, DENISE	1	0.88
DISTRICT-WIDE	ENGSTROM, HEATHER L	1	0.88
	VAURIO, SONYA	91	0.00
	WESSEN, JANE E	1	1.00
EAGLE RIDGE	BRINGGOLD, DEBBIE	1	0.94
	GILLIS, CINDY M	1	0.94
	HAYES, ERIC L	91	0.00
	LEIVA, CYNTHIA	1	0.94
	MCCRAY, SHARON	1	0.94
	MURRAY, CATHLEEN H	1	0.94
	RUIZ, WINSTON V	1	0.94
	SCHWARZ, DARCI E N	1	0.94
	ZEIMET, KARLIE	1	0.94
ECSE CENTER	ABDALLAH, HIBO SAAD	1	0.81
	ARTIGA-ROSA, PATRICIA	1	0.81
	BACHMEIER, MICHELLE M	1	0.72
	EISENBERG, RACHELLE L	1	0.81
	FREDRIKSON, KAYE E	1	0.91
	HANDRAHAN, JOANN MARY	1	0.38
	HILCHEY, LINDA M	1	0.81
	HO, LINDA S	1	0.81
	INSELMAN, SANDRA L	1	0.81
	JOHNSON, KAREN A	1	0.81
	KEIRSTEAD, AMY	1	0.81
	KIRATLI, KRISTIN E	1	0.47
	Open Position	0	0.81
	REILLY, TERRI LYNN	1	0.81
		91	0.00
	RINGGER, TRACY A	1	0.81
	SCHROEDER, GINA M	1	0.81
	SPONSEL, KAY	1	0.81

**2018 Revised Budget - Staffing by Budget Unit**

	TWARDOSKI, RUTHANN	1	0.81
	WALTERSON, KRISTEN A	1	0.81
	WEATHERFORD, ANDREA M	1	0.81
	WESLEY, JANET M	1	0.81
EDWARD NEILL	HAHNE, MICHAEL S	1	0.91
	HERMAN, LINDA R	1	0.91
	HEY, LINDA L	1	0.91
	JACKSON, KELLY J	1	0.91
	KUHLMAN, SUSAN M	1	0.91
	MULDER, AMY L	1	0.91
	POFAHL, JANELL C	1	0.91
	ROCKETT, JOAN	1	0.91
	THEIS, RACHAEL L	1	0.91
GIDEON POND	HENDRICKSON, LISA	1	0.91
	TERFEHR, DIANE C	1	0.91
HARRIET BISHOP	CARNEY, CATHERINE	1	0.91
	CHHEN, KUOY L	1	0.91
	SISLER, JANE L	91	0.00
HIDDEN VALLEY	BIAGI, LOUIS	1	0.91
	DATRES, SUSAN	1	0.91
	HUNTER, SANDRA J	91	0.00
	JONES, JEAN	1	0.91
	KIENITZ, DARLYS	1	0.91
	SANZ, MARGARET M	1	0.91
	ULRICH, KIMBERLY A	1	0.91
	WIEDEMANN, LAURA E	1	0.91
METCALF	ASHLEY, JAMES M	1	0.94
	BARR, SARAH B	1	0.94
	DAWSON, CHLOE	91	0.00
	FOUNTAIN, LYNN	91	0.00
	HOFFMAN, ERIC E	1	0.94
	HRIMNAK, SANDI J	1	0.94
	MEREDITH, BRIHANNA	1	0.94
	NEPTUNO-TEMOZAN, JULIO	1	0.94
	OLSON, PAMELA S	1	0.94
	Open Position	0	0.94
		1	0.94
	PAYNE, DEBRA K	1	0.94
	SOUCEK, MARY L	1	0.94
	THOMPSON, ROBERT L	1	0.94
	WHITE, RUTHANN	1	0.94
MW SAVAGE	ADAMSON, KIMBERLY S	1	0.91
	HICKERSON, KAREN A	1	0.91
	LUND, AMANDA L	1	0.91
	SCHILLER, LORI L	1	0.91
	VAN GUILDER, SUZANN	1	0.91
	WEBER, ROBERT D	1	0.91
NICOLLET	FELTON, MICHELLE M.	1	0.94
	FIELD, EMMA MARIE	1	0.94
	GASTON, TOMMIE	1	0.00
	GYSLAND, NEAL	1	0.94

**2018 Revised Budget - Staffing by Budget Unit**

		KAUFMAN, MARGARET M	1	0.94
		NEEDHAM, DIANE M	1	0.94
		REEVES, JONATHAN K	1	0.94
RAHN		BOLTON, ALLISSA	1	0.91
		CAMPBELL, SUSAN	1	0.91
		DROEGE, SHERYL L	1	0.91
		MISZKIEWICZ, KELLY A	1	0.91
		NOLTE, DIANE M	1	0.91
		RAICHERT, SARAH	1	0.91
		SUTTER, LINDA	1	0.91
		WEGNER, LISA L	1	0.91
		WHITE, JENNIFER M	1	0.91
SIOUX TRAIL		ANDERSON, BARBARA J	1	0.91
		FREEMAN, TAMMY S	1	0.91
		HUGHES, DEBORAH JEAN	1	0.91
		KINSELLA, ANDREW	91	0.00
		Open Position	1	0.91
			2	0.91
		PORTWOOD, MARIANNE	91	0.00
		THEYSON, BRENDA	1	0.91
SKY OAKS		AHMED, AMINA	1	0.91
		BOLDT, JULIE A	1	0.91
		BRUNETTE, ERIN	1	0.91
		CARLSON, JULIE	1	0.91
		KEGLEY, RENEE C	1	0.91
		MANSANO, KATHLEEN M	1	0.91
		SPAULDING, KRISTIE	1	0.91
VISTA VIEW		ANDREN, MARY R	91	0.00
		AUGE, ELIZABETH	1	0.91
		BROWN, RUTH	1	0.91
		CHRISTENSEN, MARY	1	0.91
		DUBANOSKI, BARBARA JEAN	1	0.91
		GILBRAITH, DAVID	1	0.91
		HALL, JENNIFER J	1	0.91
		LARSON, JOANN C	1	0.91
		LATOURELLE, SANDRA E	1	0.91
		NICHOLSON, KARISSA L	1	0.91
		ROARK, KARI L	1	0.91
		SIMPSON, DAWN	1	0.91
WM. BYRNE		BARTELLS, CAROL A	1	0.91
		BURRILL, SARAH	1	0.91
		JENSEN, JASON C	1	0.91
		KOECHLEIN, LAURIE LEEANNE	1	0.91
		Open Position	1	0.00
		SIEBEN, AMY	91	0.00
<b>SPED EA - Total</b>				<b>127.69</b>
SPED LEAD TCR	ALTERNATIVE HIGH SCHOOL	MORRIS, ANGELA J	75	0.00
	BEST	ERICKSON, SHELLY L	75	0.00
	EAGLE RIDGE	MORTINSON, ELIZABETH	75	0.00
	ECSE CENTER	OSCARSON, KRISTI R	1	0.50
			91	0.00

## 2018 Revised Budget - Staffing by Budget Unit

EDWARD NEILL	DISCHER, TRACY L	75	0.00	
GIDEON POND	LYNCH, MOLLY	75	0.00	
HARRIET BISHOP	PRED, RENEE R	75	0.00	
HIDDEN VALLEY	MILLER, ERIN M	75	0.00	
METCALF	GEDITZ, RANDALL J	75	0.00	
MW SAVAGE	BISEK, KATHRYN A	75	0.00	
NICOLLET	MCCUE, MICHELLE	75	0.00	
RAHN	WEGENER, KIMBERLY E	75	0.00	
SIOUX TRAIL	HENRICH, SARAH L	75	0.00	
SKY OAKS	SAUNDERS, SHARON D	75	0.00	
VISTA VIEW	BORRELL, MARY	75	0.00	
<b>SPED LEAD TCR - Total</b>			<b>0.50</b>	
SPED SUPERVISOR	DIAMONDHEAD	MIDDENDORF, JENNIFER L	1	1.00
		O'NEILL-MAGER, JENNIFER	1	1.00
		PIOTROWSKI, AMY	1	1.00
		SMITH, JACQUELINE J	1	1.00
<b>SPED SUPERVISOR - Total</b>			<b>4.00</b>	
SPED TCR	ALTERNATIVE HIGH SCHOOL	MORRIS, ANGELA J	1	1.00
		SCHEIT, ANDREA	2	0.20
	BEST	ANDERSON, KASEY D	1	1.00
		CHRISSIS, ERIK R	1	1.00
		SCHEIT, ANDREA	3	0.20
		SCHMIDTKE, ANGILA R	1	0.50
			2	0.50
	SEAMEN, MICHELLE A	1	1.00	
	BHS	ANDERSON, CARLY	1	1.00
		BRENNAN, CAROL ANN	1	0.34
			2	0.33
			3	0.33
		BUBAK, AYLEEN K	1	1.00
		BUNKERS, KATHLEEN K	1	1.00
		EILER, ELIZABETH P	1	1.00
		GONNELLA, MARK P	1	1.00
		GRANT, CARA	1	1.00
		HULTING, LINDA JANE	1	1.00
		JORGENSEN, STEPHANIE J	1	1.00
		KAPPEL, GENEVIEVE N	1	1.00
		MACNALLY, KATHRYN A	1	1.00
		MCCOOL, MOLLY	1	1.00
		MCPMAHON, VINCENT DE PAUL	1	1.00
		MILLER-HAYS, JULIE A	1	1.00
		NELSON, EMILY A	1	1.00
		NEUER, MICHELLE E	1	1.00
		PARKER, VICTORIA	1	1.00
	SCHROEDER, JEAN M	1	1.00	
	SMITH, ASHLEY	1	1.00	
	TOUSIGNANT, ANNETTE S	1	1.00	
	WALKER, RYAN M	1	1.00	
	WEBBER, JEFFREY	1	1.00	
WEBER, JOANNA L	1	1.00		
WILLIAMS, KAREN	1	1.00		

**2018 Revised Budget - Staffing by Budget Unit**

	WORKMAN, CAROLYN J	1	1.00
EAGLE RIDGE	BYRNE, EDWARD	1	1.00
	CHOUANARD, MARY E	1	0.60
	HALL, KRISTINA	1	1.00
	HANSON, RACHEL	1	1.00
	KRONFORST, KOREY M	1	1.00
	MORTINSON, ELIZABETH	1	1.00
	WILLIAMS, ELIZABETH	1	1.00
EDWARD NEILL	BING, DENA M	1	1.00
	DISCHER, TRACY L	1	1.00
	DOYLE, SANDRA J.	1	0.50
		2	0.50
	Open Position	1	1.00
	SIEBEN, JENNA K	1	1.00
	SULLIVAN, JODI L	1	0.50
GIDEON POND	CANTON, EMILIE J	1	0.50
	LYNCH, MOLLY	1	1.00
	RASMUSSEN, EMILY	1	1.00
HARRIET BISHOP	MILLER, JILL ELIZABETH	1	0.50
		2	0.50
	PRED, RENEE R	1	0.50
		2	0.50
HIDDEN VALLEY	BRANDON, DEBRA J	1	0.50
	CRESPIN, JASON C	1	1.00
	HARRSCH, KATHRYN	1	1.00
	MILLER, ERIN M	1	1.00
	RICHTER, LINDSAY M	1	0.50
		2	0.50
	SULLIVAN, JODI L	2	0.50
METCALF	COX, KELLY J	1	1.00
	FOLEY, COLLEEN CHARLOTTE	1	1.00
	GEDITZ, RANDALL J	1	0.50
		2	0.50
	JOHNSON, DAVID P	1	1.00
	LOGAN, KARI M	1	0.50
	NASH, DEREK B	1	1.00
	TETZLOFF, MITZI R	1	1.00
	TILLMAN, MEGAN	1	1.00
	WIGGINS, DION P	1	1.00
MW SAVAGE	BISEK, KATHRYN A	1	1.00
	HIRSCHEY, WENDY	1	0.50
	MURRAY, MARGARET E	1	1.00
	Open Position	1	1.00
	ROARK, KIMBERLY J	1	1.00
	TANGNEY, AMY K	1	0.50
		2	0.50
NICOLLET	BELL, ANGELA	1	1.00
	BLONS, LLIANE M	1	0.50
	FREDRICKS, JOEL J	1	1.00
	KNOX, JACOB M	1	1.00
	MCCUE, MICHELLE	1	1.00

**2018 Revised Budget - Staffing by Budget Unit**

		RAPPE, BRIAN	1	1.00
		SCHEIT, ANDREA	1	0.60
RAHN		BRANCH, NANCY C	1	1.00
		LAUER, LISA N	1	1.00
		NOVINE, CHERYL L	1	0.50
		ROBINETTE, SARAH-CATHERINE J	1	0.50
		WEGENER, KIMBERLY E	1	1.00
SIOUX TRAIL		CHOUANARD, MARY E	2	0.40
		HENRICH, SARAH L	1	1.00
		NELSON, KATIE L	1	0.50
		TUSHIE, PATRICIA	1	1.00
SKY OAKS		BLONS, LLIANE M	2	0.50
		CANTON, EMILIE J	2	0.50
		FECHNER, SUSAN	1	0.50
			2	0.50
		HANSON, AMY E	1	1.00
		HINNERS, JULIE	1	1.00
		SAUNDERS, SHARON D	1	1.00
		STADTHERR, ELIZABETH A	1	1.00
VISTA VIEW		BORRELL, MARY	1	1.00
		PETERSON, JULIE A	1	1.00
		SOLBERG, LAYNE A	1	1.00
		WOODS, MEGAN M	1	1.00
		ZONDAG-HAMER, KIMBERLY	1	0.50
WM. BYRNE		CRAIG, ALYSSA	1	1.00
		OGDAHL, MICHAEL A	1	1.00
		SUTTON, MEGAN E	1	1.00
		ZONDAG-HAMER, KIMBERLY	2	0.50
<b>SPED TCR - Total</b>				<b>93.00</b>
SPEECH STIPEND	BHS	BARNES, CHERISE C	74	0.00
	DISTRICT-WIDE	ALLEN, SUSAN M	74	0.00
		FAUST, DANIELLE M	74	0.00
		HJERMSTAD, HEATHER	74	0.00
		JAMISON, DARCIE L	74	0.00
		JORDAN, JOANNA	74	0.00
		KIBLER, JEANNE	74	0.00
		KLINNERT, ELIZABETH	74	0.00
		MCINNIS, MARNIE JO	74	0.00
		MEULEBROECK, SUSANNE	74	0.00
		NEAL, BRYENY B	74	0.00
		NIESEN, ELIZABETH A	74	0.00
		OSCARSON, KRISTI R	74	0.00
		REGNIER, STACY	74	0.00
		SCHLICHTING, CATHERINE	74	0.00
		SPODEN, ANNEMARIE	74	0.00
		SPRY, KARIE	74	0.00
		VODNICK, SARAH A	74	0.00
	EAGLE RIDGE	BRINKMAN, CAROLE I	74	0.00
	ECSE CENTER	BARTH, TAMI RAE	74	0.00
		HENDRIX, EUGENIA M	74	0.00
	VISTA VIEW	GOLDSMITH, EMILY R	74	0.00

## 2018 Revised Budget - Staffing by Budget Unit

SPEECH STIPEND - Total				0.00
SPEECH TCR	BEST	ALLEN, SUSAN M	3	0.25
	BHS	ALLEN, SUSAN M	2	0.25
		BARNES, CHERISE C	1	0.75
	DISTRICT-WIDE	HJERMSTAD, HEATHER	1	1.00
	EAGLE RIDGE	BERG, JANET	2	0.40
		BRINKMAN, CAROLE I	1	0.50
	ECSE CENTER	BARTH, TAMI RAE	1	1.00
		HENDRIX, EUGENIA M	1	1.00
		JORDAN, JOANNA	1	1.00
		MEULEBROECK, SUSANNE	1	1.00
		NEAL, BRYENY B	1	1.00
		NIESEN, ELIZABETH A	1	1.00
		REGNIER, STACY	2	0.50
		SCHLICHTING, CATHERINE	1	0.25
			2	0.25
		SPRY, KARIE	1	1.00
		VODNICK, SARAH A	1	1.00
	WOODCOCK, SUSAN M	1	0.80	
	EDWARD NEILL	JAMISON, DARCIE L	1	1.00
	GIDEON POND	BERG, JANET	1	0.60
	HIDDEN VALLEY	SPODEN, ANNEMARIE	1	0.50
			2	0.50
	METCALF	KIBLER, JEANNE	2	0.50
		KLINNERT, ELIZABETH	1	0.70
	MW SAVAGE	SCHUETT, DAWN J	1	1.00
	NICOLLET	KLINNERT, ELIZABETH	2	0.30
	RAHN	MCINNIS, MARNIE JO	1	0.80
	SIOUX TRAIL	KIBLER, JEANNE	1	0.50
	SKY OAKS	FAUST, DANIELLE M	1	1.00
	VISTA VIEW	GOLDSMITH, EMILY R	1	1.00
	WM. BYRNE	MCINNIS, MARNIE JO	2	0.20
		REGNIER, STACY	1	0.50
	<b>SPEECH TCR - Total</b>			
WORK EXP TCR	BEST	ERICKSON, SHELLY L	1	1.00
	BHS	LEVINSKI, SARAH A	1	1.00
<b>WORK EXP TCR - Total</b>				<b>2.00</b>
SPED EA	EDWARD NEILL	Open Position	1	0.91
<b>SPED EA - Total</b>				<b>0.91</b>
<b>09010 - Total</b>				<b>327.60</b>

### Budget Unit: 10010

Description	Location	Employee Name	Seq.	FTE
6TH GRADE TCR	EAGLE RIDGE	DAY, MARLYS L	3	0.17
		KRAFT, STEPHEN	2	0.17
		MOSEY, PATRICIA	2	0.17
		O'REILLY, GINA	2	0.17
		PELTIER, BRAD W	2	0.17
	METCALF	BARTON, DUANE	2	0.17
		CORONIS, ANTHONY L	2	0.17
		ILES, CORNELIA	2	0.17

## 2018 Revised Budget - Staffing by Budget Unit

		KHAMRATTHANOME, BOUNTHAVY	2	0.17
		LUNDAHL, TIMOTHY	2	0.17
		MIKELSON, TERESA	2	0.19
		Open Position	1	0.34
		PLANTE, MARY TRACEY	2	0.17
	NICOLLET	SMALLEY, AMY C	2	0.29
<b>6TH GRADE TCR - Total</b>				<b>2.69</b>
ACADEMIC ENRICHMENT COORD	DIAMONDHEAD	JENSEN, STEVEN	2	0.50
<b>ACADEMIC ENRICHMENT COORD - Total</b>				<b>0.50</b>
ART TCR	ALTERNATIVE HIGH SCHOOL	NAGAHASHI, ANDREW T	1	1.00
<b>ART TCR - Total</b>				<b>1.00</b>
CLERICAL	ALTERNATIVE HIGH SCHOOL	ELLIS, TENEASHA L	1	0.50
			2	0.40
			3	0.10
		HO-BUTTLEMAN, STACI	1	1.00
	DIAMONDHEAD	NAAS, ANNE B	1	0.50
<b>CLERICAL - Total</b>				<b>2.50</b>
COUNSELOR	ALTERNATIVE HIGH SCHOOL	RUSSELL, DESHA S	1	1.00
<b>COUNSELOR - Total</b>				<b>1.00</b>
DEAN	ALTERNATIVE HIGH SCHOOL	GRAY, PHILLIP E	1	1.00
<b>DEAN - Total</b>				<b>1.00</b>
LANG ARTS TCR	ALTERNATIVE HIGH SCHOOL	BERGMAN, ANNA T	2	0.25
		MEILLEUR, STEPHANIE J	1	1.00
		SLONEKER, ANGELA	1	1.00
	EAGLE RIDGE	BLAIR, MICHAEL E.	2	0.66
		DECKER, KATHRYN N	2	0.17
		ELWARD, LUCIUS P	2	0.34
		PARKINSON, JACQUELYN R	2	0.66
		WALKER, ETHAN D	2	0.34
	METCALF	HANSEN, WILLIAM C	2	0.17
		NASH, STEPHANIE	2	0.17
		ORTH, STEVEN D. R.	2	0.17
		PAUL, MADISON P	2	0.17
		SCHNOBRICH, ANGELA M	3	0.17
	NICOLLET	CHRISTENSEN, KELSEY A	1	0.51
		KELLEHER, SARAH	1	0.71
		NEMETH, HEATHER	2	0.49
		SMOLKE, ANGELA S	1	1.00
		SORENSEN, BRAD	1	0.51
<b>LANG ARTS TCR - Total</b>				<b>8.49</b>
MATH TCR	ALTERNATIVE HIGH SCHOOL	DIPPEL, JESSICA C	1	1.00
		JOHNSON, DEBRA S	1	1.00
	EAGLE RIDGE	HAGEN, ALISON M	2	0.34
		NELSON, MICHELLE L	2	0.34
		SLETTEN, ELIZABETH M	2	0.34
		WYSOCKI, STEVEN J	2	0.34
	METCALF	BENSON, ROSS S	2	0.34
		GEDDES, RICHARD W	2	0.34
		LOTZE, TIMOTHY	3	0.17
		MUELLER, SARAH K	2	0.34
	NICOLLET	FUNCHES, MONIQUE ROY	2	0.17

## 2018 Revised Budget - Staffing by Budget Unit

		GRUENEICH, JANELLE	2	0.17
		NYSTROM, ROBERT J	2	0.17
<b>MATH TCR - Total</b>				<b>5.06</b>
NURSE	ALTERNATIVE HIGH SCHOOL	COZAD, PATRICIA M	1	0.24
<b>NURSE - Total</b>				<b>0.24</b>
PHY ED TCR	ALTERNATIVE HIGH SCHOOL	MORRISSEY, KEVIN P	1	1.00
<b>PHY ED TCR - Total</b>				<b>1.00</b>
PRINCIPAL	ALTERNATIVE HIGH SCHOOL	PORTER, JANICE	1	0.84
			2	0.12
			3	0.02
			4	0.02
<b>PRINCIPAL - Total</b>				<b>1.00</b>
READING TCR	ALTERNATIVE HIGH SCHOOL	KIRCHNER, AMY	1	0.50
<b>READING TCR - Total</b>				<b>0.50</b>
SCIENCE TCR	ALTERNATIVE HIGH SCHOOL	ENGELHARDT, ANGELA C	1	1.00
		PILNEY, MAUREEN A	1	1.00
	EAGLE RIDGE	RAMBOW, CHASE R	2	0.17
	METCALF	JOHNSON, CORY CHARLES	2	0.17
		MEYER, CHAD	2	0.18
		WICKENHAUSER, KIERSTEN L	2	0.17
<b>SCIENCE TCR - Total</b>				<b>2.69</b>
SOC STU TCR	ALTERNATIVE HIGH SCHOOL	BERGMAN, ANNA T	1	0.75
		HILL, AMY M	1	1.00
		KIRCHNER, AMY	2	0.50
	EAGLE RIDGE	ALLEN, TRUDY L	2	0.17
		KLUBBERUD, MICHAEL	2	0.16
		SIMMONS, SEAN D	2	0.17
	METCALF	JEFFERS, LUCRETIA	2	0.17
		LUND, KAJ	2	0.17
	NICOLLET	ELFERING, JEAN	2	0.17
		IVERSON, ADAM	2	0.17
		SCHWEIM, ROBERT W	2	0.17
	<b>SOC STU TCR - Total</b>			
WORK EXP TCR	ALTERNATIVE HIGH SCHOOL	BATES, DANIEL W	1	0.90
<b>WORK EXP TCR - Total</b>				<b>0.90</b>
<b>10010 - Total</b>				<b>32.17</b>

### **Budget Unit: 10030**

Description	Location	Employee Name	Seq.	FTE
DIR HEALTH SERVICES	DIAMONDHEAD	WILLSON, DAWN M	1	0.80
<b>DIR HEALTH SERVICES - Total</b>				<b>0.80</b>
EA HEALTH	DISTRICT-WIDE	WITTENKELLER, JANE E	1	0.82
<b>EA HEALTH - Total</b>				<b>0.82</b>
NURSE	BHS	WALCHER, PAMELA J	2	0.47
	EAGLE RIDGE	EILERTSON, JANE ANN	1	0.33
	EDWARD NEILL	MCDERMOTT-BATY, JODY	1	0.38
	GIDEON POND	BAGGOT, LYNN	3	0.34
	HARRIET BISHOP	BAGGOT, LYNN	1	0.20
	HIDDEN VALLEY	BIEN, BERNADETTE L	1	0.27
	METCALF	WALDRON, RACHELLE	2	0.41
	MW SAVAGE	BIEN, BERNADETTE L	3	0.27
	NICOLLET	WITTNEBEL, KATHY	1	0.78

## 2018 Revised Budget - Staffing by Budget Unit

	RAHN	LATTERY, CHRISTINE A	2	0.33
	SIOUX TRAIL	BEAULIEU, KOURTNEY A	1	0.57
	SKY OAKS	COZAD, PATRICIA M	4	0.43
	VISTA VIEW	WARDELL, BARBARA J	1	0.56
	WM. BYRNE	LATTERY, CHRISTINE A	3	0.33
<b>NURSE - Total</b>				<b>5.66</b>
NURSE - REGISTERED	DISTRICT-WIDE	HAYES, JENNIFER	1	0.65
		ROBISON, KIMBERLY A	1	0.51
		SHERER, CAROL MARIE	1	0.65
		STINSON, KATRINA L	1	0.73
		WHITE, ERICA E	1	0.63
<b>NURSE - REGISTERED - Total</b>				<b>3.16</b>
<b>10030 - Total</b>				<b>10.45</b>

### Budget Unit: 11010

Description	Location	Employee Name	Seq.	FTE
6TH GRADE TCR	NICOLLET	NEMETZ, J SCOTT	2	0.49
<b>6TH GRADE TCR - Total</b>				<b>0.49</b>
ACTIVITIES COORDINATOR	BHS	SKELLY, BRIAN	1	1.00
<b>ACTIVITIES COORDINATOR - Total</b>				<b>1.00</b>
AWARDS COORDINATOR	BHS	WELKE, ASHLEY L	32	0.00
	EAGLE RIDGE	HARRISON, P SCOTT	41	0.00
		PETROSKY, KELLIE A	41	0.00
	METCALF	ORTH, STEVEN D. R.	41	0.00
	NICOLLET	LOPEZ, MARIA T	41	0.00
<b>AWARDS COORDINATOR - Total</b>				<b>0.00</b>
BAND CO-CURR ANNUAL (1)	BHS	FRENCH, KEITH J	32	0.00
<b>BAND CO-CURR ANNUAL (1) - Total</b>				<b>0.00</b>
BAND CO-CURR ANNUAL	BHS	BERENS, MICHELE E	31	0.00
		HOLMES, MOLLY	33	0.00
<b>BAND CO-CURR ANNUAL - Total</b>				<b>0.00</b>
BAND DRUMLINE (WINTER)	BHS	CONNELL, PAUL J	33	0.00
<b>BAND DRUMLINE (WINTER) - Total</b>				<b>0.00</b>
BAND, COCURRICULAR, ANNUAL	METCALF	SYLVESTER, GREGORY	41	0.00
<b>BAND, COCURRICULAR, ANNUAL - Total</b>				<b>0.00</b>
BAND, COCURRICULAR, ANNUAL	EAGLE RIDGE	ARMSTRONG, NICHOLAS G	41	0.00
	NICOLLET	BAKKEN, ANN	41	0.00
<b>BAND, COCURRICULAR, ANNUAL MS - Total</b>				<b>0.00</b>
BAND, DRUMLINE - ASST	BHS	CONNELL, PAUL J	32	0.00
		LAWSON, DERYCK I	31	0.00
<b>BAND, DRUMLINE - ASST - Total</b>				<b>0.00</b>
BAND, DRUMLINE ASST (WINTER)	BHS	FARNSWORTH-MOSES, MARKELL S	31	0.00
		LAWSON, DERYCK I	32	0.00
		SCHLAGEL, KAITLYNN	31	0.00
		SCHMEICHEL, MATTHEW T	32	0.00
<b>BAND, DRUMLINE ASST (WINTER) - Total</b>				<b>0.00</b>
BAND, DRUMLINE FALL	BHS	SCHMEICHEL, MATTHEW T	31	0.00
<b>BAND, DRUMLINE FALL - Total</b>				<b>0.00</b>
BAND, MARCHING (FALL)	BHS	FRENCH, KEITH J	31	0.00
<b>BAND, MARCHING (FALL) - Total</b>				<b>0.00</b>
BAND, MARCHING ASST	BHS	HOLMES, MOLLY	31	0.00
		SCHMEICHEL, LINDA	31	0.00

## 2018 Revised Budget - Staffing by Budget Unit

<b>BAND, MARCHING ASST - Total</b>				<b>0.00</b>
BAND, PEP	BHS	FRENCH, KEITH J	33	0.00
<b>BAND, PEP - Total</b>				<b>0.00</b>
BHS GRADUATION COORDINATOR	BHS	MEUSER, TERESA	31	0.00
<b>BHS GRADUATION COORDINATOR - Total</b>				<b>0.00</b>
BURNSVILLE STRONG	BHS	BURKE, KATIE J	31	0.00
		DUNDON, MARY LOU	32	0.00
		HANSEN, MARIE C	33	0.00
		MARSHALL, VERONICA JEAN	31	0.00
		WALLER MCDEVITT, JENNIFER	31	0.00
<b>BURNSVILLE STRONG - Total</b>				<b>0.00</b>
CHESS	BHS	FELLMAN, MICHAEL J	31	0.00
<b>CHESS - Total</b>				<b>0.00</b>
CHOREOGRAPHER MUSICAL	BHS	BAKKEN, ANN	32	0.00
<b>CHOREOGRAPHER MUSICAL - Total</b>				<b>0.00</b>
CHOREOGRAPHER SHOWCASE	BHS	BAKKEN, ANN	33	0.00
<b>CHOREOGRAPHER SHOWCASE - Total</b>				<b>0.00</b>
CLASS ADVISOR - SENIOR	BHS	DYRHAUG, MICHELLE	31	0.00
		WELKE, ASHLEY L	31	0.00
<b>CLASS ADVISOR - SENIOR - Total</b>				<b>0.00</b>
DEBATE - HEAD	BHS	ENGELHARDT, WILLIAM T	31	0.00
<b>DEBATE - HEAD - Total</b>				<b>0.00</b>
DECA ASST	BHS	CARROLL, MICHELE	31	0.00
<b>DECA ASST - Total</b>				<b>0.00</b>
DIVERSITY COORD	BHS	MCDEVITT, PAUL DAVID	32	0.00
		MILLEA, ALLISON B	33	0.00
<b>DIVERSITY COORD - Total</b>				<b>0.00</b>
DIVERSITY COORD - ASST	BHS	MCDEVITT, PAUL DAVID	33	0.00
		MILLEA, ALLISON B	34	0.00
<b>DIVERSITY COORD - ASST - Total</b>				<b>0.00</b>
DRUM LINE DRILL COMPOSER	BHS	WEIN, JORDAN M	31	0.00
<b>DRUM LINE DRILL COMPOSER - Total</b>				<b>0.00</b>
DRUMLINE COMP DRILL - ASST	BHS	LAWSON, DERYCK I	33	0.00
		WEIN, JORDAN M	32	0.00
<b>DRUMLINE COMP DRILL - ASST - Total</b>				<b>0.00</b>
DRUMLINE COMP DRILL - HEAD	BHS	CLASEMAN, ALEXANDER J	31	0.00
		KOSLOSKI, SCOTT	31	0.00
<b>DRUMLINE COMP DRILL - HEAD - Total</b>				<b>0.00</b>
DRUMLINE DRILL COMPOSER - A	BHS	ARMSTRONG, NICHOLAS G	31	0.00
<b>DRUMLINE DRILL COMPOSER - ASST - Total</b>				<b>0.00</b>
DRUMLINE DRILL COMPOSER ASST	BHS	ELLISON, NICHOLAS	31	0.00
<b>DRUMLINE DRILL COMPOSER ASST - Total</b>				<b>0.00</b>
ELEM CHORUS	EDWARD NEILL	Open Position	51	0.00
	GIDEON POND	Open Position	51	0.00
	HARRIET BISHOP	HUISMAN, MITCHELL	51	0.00
	HIDDEN VALLEY	Open Position	51	0.00
	MW SAVAGE	Open Position	51	0.00
	RAHN	Open Position	51	0.00
	SIOUX TRAIL	GEESMAN, GARRETT D	51	0.00
	SKY OAKS	SHOOK, JOANN	51	0.00
	VISTA VIEW	Open Position	51	0.00

## 2018 Revised Budget - Staffing by Budget Unit

	WM. BYRNE	Open Position	51	0.00
<b>ELEM CHORUS - Total</b>				<b>0.00</b>
ELEM STUDENT COUNCIL	EDWARD NEILL	ZAK, GLORIA	51	0.00
	GIDEON POND	STONEKING, STACY	51	0.00
	HARRIET BISHOP	CAMPEN, KIMBERLY A.	51	0.00
	HIDDEN VALLEY	ERTL, ABBY	51	0.00
	MW SAVAGE	JARZYNA-INGLES, ANNE W	51	0.00
	RAHN	HILL, KARI L	51	0.00
		PLUCINAK, JODY L	51	0.00
		SLATTERY, CARA	51	0.00
	SIOUX TRAIL	ENGBERG, DENISE G	51	0.00
	SKY OAKS	POLLITT, LINDSEY M	51	0.00
		TAYLOR, DAVID	51	0.00
	WM. BYRNE	STRANO, ANDREW	51	0.00
<b>ELEM STUDENT COUNCIL - Total</b>				<b>0.00</b>
FIRST TECH CHALLENGE	BHS	WALBERG, HEATHER K	31	0.00
<b>FIRST TECH CHALLENGE - Total</b>				<b>0.00</b>
FLAG LINE	BHS	THILTGEN, CRAIG L	31	0.00
<b>FLAG LINE - Total</b>				<b>0.00</b>
FLAG LINE - ASST	BHS	OLSON, JEFFREY T	31	0.00
<b>FLAG LINE - ASST - Total</b>				<b>0.00</b>
FUTURE EDUCATORS OF AM	BHS	MCDEVITT, PAUL DAVID	31	0.00
<b>FUTURE EDUCATORS OF AM - Total</b>				<b>0.00</b>
INSTRUMENTAL MUSIC SHOWCA	BHS	FRENCH, KEITH J	34	0.00
<b>INSTRUMENTAL MUSIC SHOWCASE - Total</b>				<b>0.00</b>
LANG ARTS TCR	METCALF	THOMAS, JESSICA	4	0.17
<b>LANG ARTS TCR - Total</b>				<b>0.17</b>
LITERARY MAGAZINE	BHS	DYRHAUG, MICHELLE	32	0.00
<b>LITERARY MAGAZINE - Total</b>				<b>0.00</b>
MARCHING BAND VISUAL DRILL	BHS	CONNELL, PAUL J	31	0.00
<b>MARCHING BAND VISUAL DRILL - Total</b>				<b>0.00</b>
MARCHING BAND VISUAL DRILL	BHS	BAUMBAUER, SARA L	31	0.00
		BECKER, JOSHUA	21	0.00
<b>MARCHING BAND VISUAL DRILL AST - Total</b>				<b>0.00</b>
MATH LEAGUE	BHS	CROATT, CHARLES C	31	0.00
	EAGLE RIDGE	NELSON, MICHELLE L	41	0.00
<b>MATH LEAGUE - Total</b>				<b>0.00</b>
MUSICAL - VOCAL	EAGLE RIDGE	HEYNE, LUCAS	41	0.00
		MUESKE, TESS	41	0.00
<b>MUSICAL - VOCAL - Total</b>				<b>0.00</b>
MUSICAL CHOREGRAPHER	BHS	BAKKEN, ANN	31	0.00
<b>MUSICAL CHOREGRAPHER - Total</b>				<b>0.00</b>
MUSICAL DIRECTOR	BHS	STEAD, AMY JO	31	0.00
			33	0.00
	EAGLE RIDGE	PARKINSON, JACQUELYN R	43	0.00
<b>MUSICAL DIRECTOR - Total</b>				<b>0.00</b>
MUSICAL DIRECTOR - SHOWCASI	BHS	HOLMES, MOLLY	34	0.00
		Open Position	31	0.00
<b>MUSICAL DIRECTOR - SHOWCASE - Total</b>				<b>0.00</b>
MUSICAL PRODUCER	BHS	ANDREWS, JEFFREY G	31	0.00
			32	0.00

## 2018 Revised Budget - Staffing by Budget Unit

<b>MUSICAL PRODUCER - Total</b>				<b>0.00</b>	
MUSICAL SET DESIGN	BHS	VAN DER WOUDE, MARK B	31	0.00	
			33	0.00	
		WOLF, NICHOLAS	31	0.00	
<b>MUSICAL SET DESIGN - Total</b>				<b>0.00</b>	
MUSICAL SET DESIGN SHOWCAS	BHS	ANDREWS, JEFFREY G	33	0.00	
<b>MUSICAL SET DESIGN SHOWCASE - Total</b>				<b>0.00</b>	
MUSICAL VOCAL	BHS	Open Position	32	0.00	
<b>MUSICAL VOCAL - Total</b>				<b>0.00</b>	
MUSICAL, DIRECTOR	NICOLLET	BAKKEN, ANN	44	0.00	
<b>MUSICAL, DIRECTOR - Total</b>				<b>0.00</b>	
MUSICAL, INSTRUMENTAL	BHS	HOLMES, MOLLY	32	0.00	
			35	0.00	
<b>MUSICAL, INSTRUMENTAL - Total</b>				<b>0.00</b>	
MUSICAL, VOCAL (FALL)	BHS	BUTLER, GARY	31	0.00	
<b>MUSICAL, VOCAL (FALL) - Total</b>				<b>0.00</b>	
NATIONAL HONOR SOCIETY	BHS	DUNDON, MARY LOU	31	0.00	
		VAN DER WOUDE, LORALIE A	31	0.00	
	EAGLE RIDGE	PARKINSON, JACQUELYN R	44	0.00	
		SAYERS, KEVIN	41	0.00	
<b>NATIONAL HONOR SOCIETY - Total</b>				<b>0.00</b>	
NEWSPAPER - ASST	BHS	EGGERS, SHEANA	31	0.00	
<b>NEWSPAPER - ASST - Total</b>				<b>0.00</b>	
PAPER, EDITORIAL	BHS	MILLEA, ALLISON B	32	0.00	
<b>PAPER, EDITORIAL - Total</b>				<b>0.00</b>	
PAPER, EDITORIAL - MS	METCALF	JEFFERS, LUCRETIA	42	0.00	
		NASH, STEPHANIE	41	0.00	
	NICOLLET	SORENSEN, BRAD	41	0.00	
<b>PAPER, EDITORIAL - MS - Total</b>				<b>0.00</b>	
PAPER, EDITORIAL ASST	BHS	STAUM, ANNE C	32	0.00	
<b>PAPER, EDITORIAL ASST - Total</b>				<b>0.00</b>	
PHYSICS CLUB - HEAD	BHS	HUBER, JON ALAN	31	0.00	
<b>PHYSICS CLUB - HEAD - Total</b>				<b>0.00</b>	
PLAY - 1 ACT SET DESIGN	BHS	VAN DER WOUDE, MARK B	36	0.00	
		WOLF, NICHOLAS	32	0.00	
<b>PLAY - 1 ACT SET DESIGN - Total</b>				<b>0.00</b>	
PLAY - FULL LENGTH DIRECTOR	METCALF	ORTH, STEVEN D. R.	43	0.00	
<b>PLAY - FULL LENGTH DIRECTOR - Total</b>				<b>0.00</b>	
PLAY FULL LENGTH SET DESIGN	BHS	VAN DER WOUDE, MARK B	34	0.00	
<b>PLAY FULL LENGTH SET DESIGN - Total</b>				<b>0.00</b>	
PLAY ONE ACT DIRECTOR	BHS	HANSEN, MARIE C	32	0.00	
		HUBBARD, MARK R	33	0.00	
		STEAD, AMY JO	32	0.00	
	EAGLE RIDGE	PARKINSON, JACQUELYN R	42	0.00	
		METCALF	ORTH, STEVEN D. R.	42	0.00
		NICOLLET	BAKKEN, ANN	43	0.00
<b>PLAY ONE ACT DIRECTOR - Total</b>				<b>0.00</b>	
PLAY, FULL LENGHT DIRECTOR	EAGLE RIDGE	PARKINSON, JACQUELYN R	41	0.00	
<b>PLAY, FULL LENGHT DIRECTOR - Total</b>				<b>0.00</b>	
PLAY, FULL LENGTH DIRECTOR	BHS	HANSEN, MARIE C	34	0.00	
<b>PLAY, FULL LENGTH DIRECTOR - Total</b>				<b>0.00</b>	

## 2018 Revised Budget - Staffing by Budget Unit

PLTW	METCALF	MALLINGER, MELINDA	2	0.17
<b>PLTW - Total</b>				<b>0.17</b>
PROUD ADVISOR	BHS	COLEMAN, COLLEEN M	32	0.00
	NICOLLET	KELLEHER, SARAH	41	0.00
		MCKENZIE, VICTORIA L	41	0.00
<b>PROUD ADVISOR - Total</b>				<b>0.00</b>
PROUD ADVISOR - ASST	BHS	AKERSON, REBECCA D	31	0.00
		WENDLING, KATHRYN	32	0.00
<b>PROUD ADVISOR - ASST - Total</b>				<b>0.00</b>
QUIZ BOWL ADVISOR	BHS	MOFFITT, LESLIE ALLAN	31	0.00
<b>QUIZ BOWL ADVISOR - Total</b>				<b>0.00</b>
QUIZ BOWL ADVISOR - MS	BHS	MOFFITT, LESLIE ALLAN	32	0.00
<b>QUIZ BOWL ADVISOR - MS - Total</b>				<b>0.00</b>
ROBOTICS	BHS	LENHARDT, ROBERT S	31	0.00
<b>ROBOTICS - Total</b>				<b>0.00</b>
SCIENCE CHALLENGE FAIR	BHS	HUEMOELLER, MICHAEL T	31	0.00
		HAMMER, JEFFREY	41	0.00
	EAGLE RIDGE	RAMBOW, CHASE R	41	0.00
		SHANNON WARNER, LINDI B	41	0.00
		JOHNSON, CORY CHARLES	41	0.00
	METCALF	PLANTE, MARY TRACEY	41	0.00
		NEMETZ, J SCOTT	41	0.00
<b>SCIENCE CHALLENGE FAIR - Total</b>				<b>0.00</b>
SCIENCE QUIZ BOWL	BHS	HUEMOELLER, MICHAEL T	32	0.00
<b>SCIENCE QUIZ BOWL - Total</b>				<b>0.00</b>
SINGERS AND SWINGERS	NICOLLET	PERKINS, TERRI M	41	0.00
<b>SINGERS AND SWINGERS - Total</b>				<b>0.00</b>
SPEECH - DECA	BHS	MALONE, MEGGAN J	31	0.00
<b>SPEECH - DECA - Total</b>				<b>0.00</b>
SPEECH - HEAD	BHS	DYRHAUG, MICHELLE	33	0.00
<b>SPEECH - HEAD - Total</b>				<b>0.00</b>
STEP TEAM	BHS	ABIODUN, ADEDOYIN R	21	0.00
<b>STEP TEAM - Total</b>				<b>0.00</b>
STUDENT COUNCIL	BHS	RIGGS, MARK D	31	0.00
<b>STUDENT COUNCIL - Total</b>				<b>0.00</b>
STUDENT COUNCIL - MS	EAGLE RIDGE	ELWARD, LUCIUS P	41	0.00
		HAGEN, ALISON M	41	0.00
	METCALF	MAIDMENT, LORI	42	0.00
		SODERHOLM, JOHN	41	0.00
	NICOLLET	IVERSON, ADAM	41	0.00
<b>STUDENT COUNCIL - MS - Total</b>				<b>0.00</b>
STUDIO PRODUCER	BHS	HUBBARD, MARK R	32	0.00
<b>STUDIO PRODUCER - Total</b>				<b>0.00</b>
THEATER MANAGER	BHS	ANDREWS, JEFFREY G	34	0.00
		HUBBARD, MARK R	31	0.00
<b>THEATER MANAGER - Total</b>				<b>0.00</b>
VOCAL COCURRICULAR TOTAL	BHS	SCHMIDT, MARTHA H	31	0.00
<b>VOCAL COCURRICULAR TOTAL - Total</b>				<b>0.00</b>
VOCAL COCURRICULAR TOTAL ASST	BHS	ANDERSON, JACLYN C	32	0.00
<b>VOCAL COCURRICULAR TOTAL ASST - Total</b>				<b>0.00</b>
VOCAL FREESTYLE	BHS	ANDERSON, JACLYN C	31	0.00

## 2018 Revised Budget - Staffing by Budget Unit

<b>VOCAL FREESTYLE - Total</b>				<b>0.00</b>
VOCAL, COCURRICULAR TOTAL MS	NICOLLET	BAKKEN, ANN	42	0.00
<b>VOCAL, COCURRICULAR TOTAL MS - Total</b>				<b>0.00</b>
WRITING CENTER	BHS	HANSEN, MARIE C	31	0.00
<b>WRITING CENTER - Total</b>				<b>0.00</b>
YEARBOOK	BHS	MILLEA, ALLISON B	31	0.00
<b>YEARBOOK - Total</b>				<b>0.00</b>
YEARBOOK - ASST	BHS	STAUM, ANNE C	31	0.00
<b>YEARBOOK - ASST - Total</b>				<b>0.00</b>
YEARBOOK - MS	EAGLE RIDGE	FLYNN, CATHERINE T	42	0.00
	METCALF	MAIDMENT, LORI	44	0.00
	NICOLLET	IVERSON, ADAM	42	0.00
<b>YEARBOOK - MS - Total</b>				<b>0.00</b>
YOUTH IN GOVERNMENT	BHS	COLEMAN, COLLEEN M	31	0.00
		WENDLING, KATHRYN	31	0.00
	EAGLE RIDGE	KLUBBERUD, MICHAEL	41	0.00
	METCALF	FRIENDT, ANDREA LYNN	41	0.00
		MUELLER, SARAH K	41	0.00
NICOLLET	MCCUE, MICHELLE	41	0.00	
<b>YOUTH IN GOVERNMENT - Total</b>				<b>0.00</b>
<b>11010 - Total</b>				<b>1.83</b>

### **Budget Unit: 11020**

Description	Location	Employee Name	Seq.	FTE
ADAPTED ATHLETIC COORDINATOR	BHS	JOHNSON, RONNA E	31	0.00
<b>ADAPTED ATHLETIC COORDINATOR - Total</b>				<b>0.00</b>
ALPINE SKIING - ASST	BHS	BOCKLUND, DANIEL J	21	0.00
<b>ALPINE SKIING - ASST - Total</b>				<b>0.00</b>
ALPINE SKIING - HEAD	BHS	BOCKLUND, TIMOTHY	21	0.00
		NASH, DEREK B	22	0.00
<b>ALPINE SKIING - HEAD - Total</b>				<b>0.00</b>
ATHLETIC COORDINATOR	BHS	RIGGS, MARK D	32	0.00
<b>ATHLETIC COORDINATOR - Total</b>				<b>0.00</b>
BADMINTON - ASST	BHS	MARSHALL, VERONICA JEAN	21	0.00
<b>BADMINTON - ASST - Total</b>				<b>0.00</b>
BADMINTON - HEAD	BHS	LIMKE, JEFFREY	21	0.00
<b>BADMINTON - HEAD - Total</b>				<b>0.00</b>
BADMINTON HEAD MS	BHS	NGUYEN, ANTHONY	21	0.00
<b>BADMINTON HEAD MS - Total</b>				<b>0.00</b>
BASEBALL - ASST	BHS	BANITT, JUSTIN	21	0.00
		DUNGEY, NATHAN	21	0.00
		FLUG, JOSHUA W	24	0.00
		HOLMQUIST, MICHAEL W	22	0.00
		REUSS, ERIC	21	0.00
		SMALLEY, MICHAEL J	21	0.00
		WEBER, ROBERT D	21	0.00
<b>BASEBALL - ASST - Total</b>				<b>0.00</b>
BASEBALL - ASST MS	BHS	JOHN, WILLIAM D	22	0.00
		MARTINEZ, CHRISTIAN	21	0.00
<b>BASEBALL - ASST MS - Total</b>				<b>0.00</b>
BASEBALL - HEAD	BHS	SCHOLL, WAYNE	21	0.00
<b>BASEBALL - HEAD - Total</b>				<b>0.00</b>

## 2018 Revised Budget - Staffing by Budget Unit

BASEBALL - HEAD MS	BHS	FENDLER, BRAD	21	0.00
		LAMOTTE, JORDAN E	22	0.00
<b>BASEBALL - HEAD MS - Total</b>				<b>0.00</b>
BASKETBALL - ASST BOYS	BHS	DAVIS, ALEXANDER CE	21	0.00
		EUSTICE, HUNTER D	21	0.00
		FLUG, JOSHUA W	22	0.00
			23	0.00
		QUAMME, DAVID R	21	0.00
		READER, SCOTT	21	0.00
		WALKER, ETHAN D	21	0.00
<b>BASKETBALL - ASST BOYS - Total</b>				<b>0.00</b>
BASKETBALL - ASST GIRLS	BHS	DANIELS, ISHA K	21	0.00
		HOPPER, MICHAEL J	21	0.00
		KINSELLA, JOSEPH	22	0.00
		PERKINS, JAYA	21	0.00
<b>BASKETBALL - ASST GIRLS - Total</b>				<b>0.00</b>
BASKETBALL - HEAD (MS)	METCALF	KHAMRATTHANOME, BOUNTHAVY	22	0.00
<b>BASKETBALL - HEAD (MS) - Total</b>				<b>0.00</b>
BASKETBALL - HEAD BOYS	BHS	EPPEN, MATTHEW W	21	0.00
<b>BASKETBALL - HEAD BOYS - Total</b>				<b>0.00</b>
BASKETBALL - HEAD GIRLS	BHS	HODGES, MAURICE	21	0.00
<b>BASKETBALL - HEAD GIRLS - Total</b>				<b>0.00</b>
CC RUNNING - ASST (MS)	EAGLE RIDGE	WYSOCKI, STEVEN J	21	0.00
	METCALF	MIKELSON, TERESA	21	0.00
<b>CC RUNNING - ASST (MS) - Total</b>				<b>0.00</b>
CC RUNNING - ASST BOYS	BHS	STRAND, NATHAN R	21	0.00
<b>CC RUNNING - ASST BOYS - Total</b>				<b>0.00</b>
CC RUNNING - ASST GIRLS	BHS	BOUSU, MOLLIE J	21	0.00
<b>CC RUNNING - ASST GIRLS - Total</b>				<b>0.00</b>
CC RUNNING - HEAD (MS)	BHS	MOSEY, PATRICIA	21	0.00
		SORENSEN, BRAD	21	0.00
<b>CC RUNNING - HEAD (MS) - Total</b>				<b>0.00</b>
CC RUNNING - HEAD BOYS	BHS	WEBBER, JEFFREY	21	0.00
<b>CC RUNNING - HEAD BOYS - Total</b>				<b>0.00</b>
CC RUNNING - HEAD GIRLS	BHS	BURNHAM, CHARLES F	21	0.00
<b>CC RUNNING - HEAD GIRLS - Total</b>				<b>0.00</b>
CHEER, ANNUAL	BHS	GAUTHIER, JACQUELINE	21	0.00
<b>CHEER, ANNUAL - Total</b>				<b>0.00</b>
CHEER, ANNUAL ASST	BHS	REAN, MADISON L	21	0.00
<b>CHEER, ANNUAL ASST - Total</b>				<b>0.00</b>
CHEER, COMP HEAD	BHS	GARDINER, STACI L	21	0.00
<b>CHEER, COMP HEAD - Total</b>				<b>0.00</b>
CLASS ADVISOR - JUNIOR	BHS	RIGGS, MARK D	33	0.00
<b>CLASS ADVISOR - JUNIOR - Total</b>				<b>0.00</b>
CLERICAL	BHS	RIGGS, JEANINE L	1	1.00
<b>CLERICAL - Total</b>				<b>1.00</b>
DANCELIN PERFORMANCE - ASST	BHS	KRALLMAN, JAMIE A	21	0.00
		LARSON, MACKENZIE	21	0.00
		SAMMIS, JORDYN P	21	0.00
			22	0.00
<b>DANCELIN PERFORMANCE - ASST - Total</b>				<b>0.00</b>

## 2018 Revised Budget - Staffing by Budget Unit

DANCELINER PERFORMANCE - HE/	BHS	LEIPOLD, MADELINE M	21	0.00
<b>DANCELINER PERFORMANCE - HEAD - Total</b>				<b>0.00</b>
DANCELINER, COMP ASST	BHS	BONVINO, ALEXANDRA	21	0.00
		KASHEVATSKY, KATHERINE	21	0.00
		PALMQUIST, ABIGAIL	21	0.00
		THOMAS, MEGAN K	21	0.00
		WALLER MCDEVITT, JENNIFER	21	0.00
<b>DANCELINER, COMP ASST - Total</b>				<b>0.00</b>
DANCELINER, COMP HEAD	BHS	ABBE, ANNA P	21	0.00
<b>DANCELINER, COMP HEAD - Total</b>				<b>0.00</b>
DIR ACTIVITIES	BHS	MARSHALL, JEFFREY	91	0.00
		PAEK, GUILLAUME J	1	1.00
<b>DIR ACTIVITIES - Total</b>				<b>1.00</b>
EA LEVEL 3	BHS	PULLEY, ERIC D	2	0.38
<b>EA LEVEL 3 - Total</b>				<b>0.38</b>
EQUIPMENT MANAGER	BHS	VAN DER WOUDE, MARK B	35	0.00
<b>EQUIPMENT MANAGER - Total</b>				<b>0.00</b>
FOOTBALL - ASST	BHS	CARLSON, JAMES L	21	0.00
		DIXON, DAVE T	21	0.00
		FLUG, JOSHUA W	21	0.00
		KINSELLA, JOSEPH	21	0.00
		LERFALD, JUSTIN	21	0.00
		PULLEY, ERIC D	21	0.00
<b>FOOTBALL - ASST - Total</b>				<b>0.00</b>
FOOTBALL - ASST (MS)	BHS	ANDREASEN, ARNOLD	21	0.00
		JOHN, WILLIAM D	21	0.00
		KHAMRATTHANOME, BOUNTHAVY	21	0.00
<b>FOOTBALL - ASST (MS) - Total</b>				<b>0.00</b>
FOOTBALL - HEAD	BHS	VARNPNESS, VINCENT C	21	0.00
<b>FOOTBALL - HEAD - Total</b>				<b>0.00</b>
FOOTBALL - HEAD (MS)	BHS	LAMOTTE, JORDAN E	21	0.00
		MCDEVITT, PAUL DAVID	21	0.00
		TESTER, ERIC	21	0.00
<b>FOOTBALL - HEAD (MS) - Total</b>				<b>0.00</b>
GOLF - ASST BOYS	BHS	HEWETT, THOMAS	21	0.00
<b>GOLF - ASST BOYS - Total</b>				<b>0.00</b>
GOLF - ASST GIRLS	BHS	VAN DER WOUDE, LORALIE A	23	0.00
<b>GOLF - ASST GIRLS - Total</b>				<b>0.00</b>
GOLF - HEAD BOYS	BHS	OPATZ, LARRY	21	0.00
<b>GOLF - HEAD BOYS - Total</b>				<b>0.00</b>
GOLF - HEAD GIRLS	BHS	LEONARD, RICHARD JOHN	21	0.00
		MORRISSETTE, BRUCE P	21	0.00
<b>GOLF - HEAD GIRLS - Total</b>				<b>0.00</b>
HOCKEY - ASST BOYS	BHS	BEAULIEU, STEPHEN J	21	0.00
		BOESER, DAN M	21	0.00
		ENGUM, BODHI J	21	0.00
		HOLMQUIST, MICHAEL W	21	0.00
		SENTA, FRANK D	21	0.00
		SENTA, JACOB	21	0.00
<b>HOCKEY - ASST BOYS - Total</b>				<b>0.00</b>
HOCKEY - ASST GIRLS	BHS	ANDERSON, WYATT R	21	0.00

## 2018 Revised Budget - Staffing by Budget Unit

		CASSANO, MICHAEL	21	0.00
		ENGSTROM, LEE	21	0.00
			22	0.00
		GONZALEZ-CAMERON, DAVID	21	0.00
		RADEMACHER, KALIE L	21	0.00
		SCHRAM, AARON	21	0.00
<b>HOCKEY - ASST GIRLS - Total</b>				<b>0.00</b>
HOCKEY - HEAD BOYS	BHS	KIVIHALME, JANNE J	21	0.00
<b>HOCKEY - HEAD BOYS - Total</b>				<b>0.00</b>
HOCKEY - HEAD GIRLS	BHS	CASSANO, TRACY	21	0.00
<b>HOCKEY - HEAD GIRLS - Total</b>				<b>0.00</b>
LACROSSE - ASST BOYS	BHS	FREDERICKS, CHARLES D	21	0.00
		PESTER, NEAL	21	0.00
		RECK, DUANE	21	0.00
		SCHROEDER, COLLIN	21	0.00
<b>LACROSSE - ASST BOYS - Total</b>				<b>0.00</b>
LACROSSE - ASST GIRLS	BHS	CEOLA, MICHAEL	21	0.00
<b>LACROSSE - ASST GIRLS - Total</b>				<b>0.00</b>
LACROSSE - HEAD BOYS	BHS	CHILDS, CORY A	21	0.00
<b>LACROSSE - HEAD BOYS - Total</b>				<b>0.00</b>
LACROSSE - HEAD GIRLS	BHS	CZAPAR, RYAN J	21	0.00
		SHREEVE, EMILY	21	0.00
<b>LACROSSE - HEAD GIRLS - Total</b>				<b>0.00</b>
MUSICAL DIRECTOR ASST	EAGLE RIDGE	WALKER, ETHAN D	41	0.00
<b>MUSICAL DIRECTOR ASST - Total</b>				<b>0.00</b>
NORDIC SKIING - ASST	BHS	NEUER, MICHELLE E	21	0.00
		POWERS, JENNA E	21	0.00
<b>NORDIC SKIING - ASST - Total</b>				<b>0.00</b>
NORDIC SKIING - HEAD	BHS	SCHLAGER, DEREK A	21	0.00
<b>NORDIC SKIING - HEAD - Total</b>				<b>0.00</b>
SOCCER - ASST BOYS	BHS	BLAZQUEZ, JAVIER	21	0.00
		ENGLE, JOSEPH	21	0.00
		MCCONNELL, THOMAS J	21	0.00
		SANKOH, MOHAMED	21	0.00
			22	0.00
<b>SOCCER - ASST BOYS - Total</b>				<b>0.00</b>
SOCCER - ASST GIRLS	BHS	HELBERG, MEGAN H	21	0.00
			22	0.00
		KRONFORST, KOREY M	21	0.00
		MATTISON, SCOT CHARLES	21	0.00
<b>SOCCER - ASST GIRLS - Total</b>				<b>0.00</b>
SOCCER - HEAD BOYS	BHS	TORANZA, GUILLERMO	21	0.00
<b>SOCCER - HEAD BOYS - Total</b>				<b>0.00</b>
SOCCER - HEAD BOYS (MS)	BHS	FEIG, PETER E	21	0.00
		SILBERMAN, KEVIN	21	0.00
<b>SOCCER - HEAD BOYS (MS) - Total</b>				<b>0.00</b>
SOCCER - HEAD GIRLS	BHS	SODERHOLM, JOHN	21	0.00
<b>SOCCER - HEAD GIRLS - Total</b>				<b>0.00</b>
SOCCER - HEAD GIRLS (MS)	BHS	SODERHOLM, WM ERIC	21	0.00
<b>SOCCER - HEAD GIRLS (MS) - Total</b>				<b>0.00</b>
SOFTBALL - ASST	BHS	AKERSON, REBECCA D	21	0.00

## 2018 Revised Budget - Staffing by Budget Unit

		EICH, SAMANTHA E	21	0.00
		HARAZIN, ABIGAIL	21	0.00
		ROSARIO, DAYJA	21	0.00
<b>SOFTBALL - ASST - Total</b>				<b>0.00</b>
SOFTBALL - ASST MS	BHS	KINSELLA, JOSEPH	23	0.00
		LILLY, JOHN	21	0.00
<b>SOFTBALL - ASST MS - Total</b>				<b>0.00</b>
SOFTBALL - HEAD	BHS	MCGOWAN, RACHEL M	22	0.00
<b>SOFTBALL - HEAD - Total</b>				<b>0.00</b>
SWIMMING - ASST	BHS	DUSBABEK, MARK	21	0.00
		DVORAK, ABBY	21	0.00
			22	0.00
		REYNOLDS, CHELSEA L	21	0.00
		VOGT, KENDRA M	21	0.00
<b>SWIMMING - ASST - Total</b>				<b>0.00</b>
SWIMMING - ASST BOYS	BHS	HAYCRAFT, KATIE N	21	0.00
		WHITE, CHRISTOPHER	21	0.00
<b>SWIMMING - ASST BOYS - Total</b>				<b>0.00</b>
SWIMMING - HEAD BOYS	BHS	TIERNEY, PAUL J	21	0.00
<b>SWIMMING - HEAD BOYS - Total</b>				<b>0.00</b>
SWIMMING - HEAD GIRLS	BHS	HARROD, KIMBERLEE N	21	0.00
<b>SWIMMING - HEAD GIRLS - Total</b>				<b>0.00</b>
TENNIS - ASST BOYS	BHS	STRADER, ANN E	21	0.00
<b>TENNIS - ASST BOYS - Total</b>				<b>0.00</b>
TENNIS - ASST GIRLS	BHS	MCMAHON, VINCENT DE PAUL	21	0.00
<b>TENNIS - ASST GIRLS - Total</b>				<b>0.00</b>
TENNIS - BOYS ASST	BHS	EGGERS, SHEANA	21	0.00
<b>TENNIS - BOYS ASST - Total</b>				<b>0.00</b>
TENNIS - BOYS HEAD	BHS	HADDORFF, RYAN	22	0.00
<b>TENNIS - BOYS HEAD - Total</b>				<b>0.00</b>
TENNIS - GIRLS (MS)	NICOLLET	MCGOWAN, RACHEL M	21	0.00
<b>TENNIS - GIRLS (MS) - Total</b>				<b>0.00</b>
TENNIS - HEAD BOYS	BHS	Open Position	21	0.00
<b>TENNIS - HEAD BOYS - Total</b>				<b>0.00</b>
TENNIS - HEAD GIRLS	BHS	HADDORFF, RYAN	21	0.00
<b>TENNIS - HEAD GIRLS - Total</b>				<b>0.00</b>
TRACK - ASST BOYS	BHS	HUGSTAD-VAA, JENNIFER JO	21	0.00
		SILBERMAN, KEVIN	22	0.00
		WEBBER, JEFFREY	22	0.00
		WELLS, DIRK	21	0.00
<b>TRACK - ASST BOYS - Total</b>				<b>0.00</b>
TRACK - ASST GIRLS	BHS	KHAMRATTHANOME, BOUNTHAVY	23	0.00
		PHOUSIRITH, ANOULACK	22	0.00
		SCHLAGER, DEREK A	22	0.00
		STRAND, JORDAN	21	0.00
<b>TRACK - ASST GIRLS - Total</b>				<b>0.00</b>
TRACK - HEAD BOYS	BHS	FEIG, PETER E	22	0.00
<b>TRACK - HEAD BOYS - Total</b>				<b>0.00</b>
TRACK - HEAD GIRLS	BHS	WINTERLIN, JEFFREY	21	0.00
<b>TRACK - HEAD GIRLS - Total</b>				<b>0.00</b>
VOLLEYBALL - ASST	BHS	KLEIN, RAVEN P	21	0.00

## 2018 Revised Budget - Staffing by Budget Unit

		REAMES, WHITNEY	21	0.00
<b>VOLLEYBALL - ASST - Total</b>				<b>0.00</b>
VOLLEYBALL - HEAD	BHS	RAEBEL, BETH A	21	0.00
<b>VOLLEYBALL - HEAD - Total</b>				<b>0.00</b>
VOLLEYBALL - HEAD (MS)	BHS	HAGEN, ALISON M	21	0.00
			22	0.00
		VAN DER WOUDE, LORALIE A	21	0.00
			22	0.00
		YOUNG, ABBY	21	0.00
<b>VOLLEYBALL - HEAD (MS) - Total</b>				<b>0.00</b>
WEIGHT ROOM	BHS	VARNNESS, VINCENT C	22	0.00
<b>WEIGHT ROOM - Total</b>				<b>0.00</b>
WEIGHT ROOM - HEAD	BHS	LERFALD, JUSTIN	22	0.00
<b>WEIGHT ROOM - HEAD - Total</b>				<b>0.00</b>
WEIGHTROOM - ASST	BHS	HUYNH, VINH T	21	0.00
		PHOUSIRITH, ANOULACK	21	0.00
<b>WEIGHTROOM - ASST - Total</b>				<b>0.00</b>
WEIGHTROOM - HEAD	BHS	VAN DER WOUDE, MARK B	32	0.00
<b>WEIGHTROOM - HEAD - Total</b>				<b>0.00</b>
WRESTLING - ASST	BHS	HOLT, CLAYTON B	21	0.00
		SELLARS, ANDRE Q	21	0.00
<b>WRESTLING - ASST - Total</b>				<b>0.00</b>
<b>11020 - Total</b>				<b>2.38</b>

### Budget Unit: 12010

Description	Location	Employee Name	Seq.	FTE	
2ND GRADE TCR	HIDDEN VALLEY	TAACK, GINA	1	1.00	
<b>2ND GRADE TCR - Total</b>				<b>1.00</b>	
CLERICAL	DIAMONDHEAD	CECKA, NANETTE	2	0.25	
		SHERIN, JUDITH L	1	1.00	
<b>CLERICAL - Total</b>				<b>1.25</b>	
EA LEVEL 3	EDWARD NEILL	SPOTT, ANNE B	1	0.31	
			2	0.38	
	GIDEON POND	ABDI, RAHIMA A	92	0.00	
	HIDDEN VALLEY	ERNST, SAMANTHA	1	0.91	
			JOHNSON, PAIGE K	1	0.94
			SCHAFFER, CARMEN	2	0.13
	RAHN	ARAKAWA, DEBORAH J	1	0.78	
	VISTA VIEW	TILLMAN, JACK R	2	0.09	
WM. BYRNE	LOPEZ, JANET	1	0.63		
<b>EA LEVEL 3 - Total</b>				<b>4.16</b>	
EA MEDIA	HIDDEN VALLEY	SCHATZLEIN, RACHEL	2	0.13	
<b>EA MEDIA - Total</b>				<b>0.13</b>	
FOCUS COACH	SKY OAKS	ZEIGLER, SARAH	2	0.30	
<b>FOCUS COACH - Total</b>				<b>0.30</b>	
SISA COORDINATOR	DIAMONDHEAD	GULDEN, JANET	1	1.00	
		VAN OSDEL, BETHANY A	1	0.50	
<b>SISA COORDINATOR - Total</b>				<b>1.50</b>	
SOCIAL WORKER	HIDDEN VALLEY	REICHERT, KRISTEN K	2	0.50	
<b>SOCIAL WORKER - Total</b>				<b>0.50</b>	
TITLE 1 TCR	EDWARD NEILL	HERKENHOFF, PATRICIA ANN	1	1.00	
	GIDEON POND	HASSAN, QORSHO	1	1.00	

## 2018 Revised Budget - Staffing by Budget Unit

HIDDEN VALLEY	NURMELA, CRYSTAL	2	0.50
MW SAVAGE	HARVES, NICOLE R	1	0.80
RAHN	KEULER, LORI J	2	0.50
SIOUX TRAIL	HENDRICKSON, CAROLINE	1	0.50
	WENING, ALESHA	1	0.50
SKY OAKS	CUNNIEN, LAURIE A	2	0.50
	DAVIDSON, JESSICA J	1	1.00
	RISTEAU, JILL A	1	0.70
ST JOHNS	PFEIFFER, DONNA M	1	0.40
VISTA VIEW	COUNTERS, ERICA M	1	1.00
WM. BYRNE	SPRINGER, MELISSA A	1	1.00

<b>TITLE 1 TCR - Total</b>	<b>9.40</b>
----------------------------	-------------

<b>12010 - Total</b>	<b>18.23</b>
----------------------	--------------

### Budget Unit: 12020

Description	Location	Employee Name	Seq.	FTE
SISA COORDINATOR	DIAMONDHEAD	SHANLEY, SARAH J	91	0.00
		VAN OSDEL, BETHANY A	2	0.50

<b>SISA COORDINATOR - Total</b>	<b>0.50</b>
---------------------------------	-------------

<b>12020 - Total</b>	<b>0.50</b>
----------------------	-------------

### Budget Unit: 12030

Description	Location	Employee Name	Seq.	FTE
CLERICAL	DIAMONDHEAD	NAAS, ANNE B	2	0.50

<b>CLERICAL - Total</b>	<b>0.50</b>
-------------------------	-------------

ESL COORDINATOR	DIAMONDHEAD	KROHN, JULIE C	1	1.00
-----------------	-------------	----------------	---	------

<b>ESL COORDINATOR - Total</b>	<b>1.00</b>
--------------------------------	-------------

<b>12030 - Total</b>	<b>1.50</b>
----------------------	-------------

### Budget Unit: 13010

Description	Location	Employee Name	Seq.	FTE	
BLT	ALTERNATIVE HIGH SCHOOL	BERGMAN, ANNA T	71	0.00	
		HILL, AMY M	71	0.00	
		NAGAHASHI, ANDREW T	71	0.00	
		RUSSELL, DESHA S	71	0.00	
	BEST		ERICKSON, SHELLY L	71	0.00
			SEAMEN, MICHELLE A	71	0.00
	BHS		AAMODT, WILLIAM P	71	0.00
			ASFELD, BETH M	71	0.00
			CARROLL, MICHELE	71	0.00
			DUNDON, MARY LOU	71	0.00
			EICHTEN, HEIDI J	71	0.00
			HARROD, KIMBERLEE N	71	0.00
			HOLMES, MOLLY	71	0.00
			MILINOVICH, CHRIS M	71	0.00
			MILLEA, ALLISON B	71	0.00
			MOREN, KIMBERLY J	71	0.00
			OIE, ROGER	71	0.00
			VAN DER WOUDE, LORALIE A	71	0.00
			WELKE, ASHLEY L	71	0.00
			WOLF, NICHOLAS	71	0.00
WORKMAN, CAROLYN J	71	0.00			
CLUSTER - ELEMENTARY		KIBLER, JEANNE	71	0.00	
CLUSTER - SEC		Open Position	71	0.00	

**2018 Revised Budget - Staffing by Budget Unit**

	SCHEIT, ANDREA	71	0.00
DIAMONDHEAD	EDMONSON, SUSAN L	71	0.00
	GILES, SHARI M THEIS	71	0.00
	MUNSON, KIMBERLY M	92	0.00
	SAMPERS, CYNTHIA	71	0.00
	TAYLOR, JORDAN A-M	71	0.00
DISTRICT-WIDE	KOMAR, KAREN K	71	0.00
	MCLAUGHLIN, ALEXANDRA M	71	0.00
EAGLE RIDGE	GALLAND, JOHN	71	0.00
	HAMMER, JEFFREY	71	0.00
	HENDERSON, MICHELLE A	71	0.00
	HERMES, SHELLEY	71	0.00
	KLUBBERUD, MICHAEL	71	0.00
	KRAFT, STEPHEN	71	0.00
	PARKINSON, JACQUELYN R	71	0.00
ECSE CENTER	JORGENSON, SHANNON E	71	0.00
	KELLER, KATIE	71	0.00
	ORLICH-SULLIVAN, MEGAN	71	0.00
	RENKEN, CARISSA M	71	0.00
EDWARD NEILL	ANDERSON, BJORN RS	71	0.00
	BING, DENA M	71	0.00
	GILRAY, REBECCA J	71	0.00
	KUGLER, JULIE	71	0.00
	OLSEN, LAURA	71	0.00
	TRANBY, BONITA K.	71	0.00
GIDEON POND	CORROW, JENNA R	71	0.00
	KING, DANIEL AUSTIN	71	0.00
	MIRS, LAUREL	71	0.00
	ODEGARD, ELISA	71	0.00
	ROBISON, THOMAS C	71	0.00
	ROLLIE, ALEXIS K	71	0.00
HARRIET BISHOP	CORONIS, STACY S	71	0.00
	PHILLIPS, MARIA	71	0.00
	SCHMIDT-BOYLES, DAWN	71	0.00
	STROWBRIDGE, STACI	71	0.00
HIDDEN VALLEY	ANDERSON, KRISTEN L	71	0.00
	CARLSON, JENNIFER A	71	0.00
	MICHELS, CHRISTINE	71	0.00
	TOLLERUD, TERESA JO	71	0.00
METCALF	FRITZ, KIMBERLY A	71	0.00
	KRUPKE, GRETA	71	0.00
	MAIDMENT, LORI	71	0.00
	ORTH, STEVEN D. R.	71	0.00
	TETZLOFF, MITZI R	71	0.00
	THOMAS, JESSICA	71	0.00
MW SAVAGE	CHESLA, PATRICK J	71	0.00
	HARVES, NICOLE R	71	0.00
	LORAN, KERIANNE N	71	0.00
	SANDS, ANNE	71	0.00
	TOFTE, ALEXANDER J	71	0.00
NICOLLET	BELL, ANGELA	71	0.00

**2018 Revised Budget - Staffing by Budget Unit**

		ELFERING, JEAN	71	0.00
		FUNCHES, MONIQUE ROY	71	0.00
		IVERSON, ADAM	71	0.00
		MCCUE, MICHELLE	71	0.00
		RUFF, HAILEY C	71	0.00
		SMALLEY, AMY C	71	0.00
RAHN		CASSERLY-SMITH, MARY	71	0.00
		KOHN, GRACE M	71	0.00
		PETERSON, KERI	71	0.00
		TOFTE, ALISSA G	71	0.00
SIOUX TRAIL		BIRCH, NANCY A	71	0.00
		HORWART, LESLIE	71	0.00
		ODEGARD, ELIZABETH A	71	0.00
		PEDERSON, ELIZABETH M	71	0.00
SKY OAKS		BERG, MATTHEW T	71	0.00
		CUNNIEN, LAURIE A	71	0.00
		PUTMAN, TANJA	71	0.00
		RIPHENBURG, WENDY A	71	0.00
		SINGLETON, SARAH K	71	0.00
		ZEIGLER, SARAH	71	0.00
VISTA VIEW		BELGRAVE, ANGELA I	71	0.00
		CRAWFORD, CINDY Y	71	0.00
		HOUTMAN, JENNIFER L	71	0.00
		STEEG, KIMBERLY KAYE	71	0.00
WM. BYRNE		CALNON, JENNIFER	71	0.00
		COOPER, KIRENZA I	71	0.00
		HANSON, LISA	71	0.00
		SIMPSON, LISA	71	0.00
<b>BLT - Total</b>				<b>0.00</b>
CONTINUOUS IMPROVEMENT CO	DISTRICT-WIDE	ALVEY, HEATHER	1	0.80
			11	0.20
			73	0.00
		BOHR, JENNIFER L	1	1.00
			73	0.00
		CHALLGREN, MARGARET TEN BROEK	1	1.00
			73	0.00
		CIN, STEPHANIE P	1	1.00
			73	0.00
		FLIKEID, TASHA	1	1.00
			73	0.00
		LUTZ, AMANDA J	73	0.00
		PLASCHKO, MARY BETH	73	0.00
		PRANSCHKE, STEPHANIE T	73	0.00
		REID, LISA M	1	1.00
		SMITH, KELLY L	1	1.00
			73	0.00
<b>CONTINUOUS IMPROVEMENT COACH - Total</b>				<b>7.00</b>
<b>13010 - Total</b>				<b>7.00</b>

**Budget Unit: 13020**

Description	Location	Employee Name	Seq.	FTE
AVID COORDINATOR	ALTERNATIVE HIGH SCHOOL	BATES, DANIEL W	2	0.10

## 2018 Revised Budget - Staffing by Budget Unit

	BHS	MOULSOFF, NORINE L	2	0.10
	EAGLE RIDGE	KLUBBERUD, MICHAEL	3	0.10
	METCALF	THOMAS, JESSICA	2	0.10
	NICOLLET	SMALLEY, AMY C	3	0.10
<b>AVID COORDINATOR - Total</b>				<b>0.50</b>
AVID TCR	EAGLE RIDGE	CZAPAR, RYAN J	2	0.17
		SCHROEDER, PATRICIA	2	0.17
		SHANNON WARNER, LINDI B	2	0.17
	METCALF	KRUPKE, GRETA	2	0.17
		LOTZE, TIMOTHY	2	0.17
<b>AVID TCR - Total</b>				<b>0.85</b>
AVID TUTOR	DISTRICT-WIDE	ANDEMAR, PATRICIA	61	0.00
		ANDERSEN, ABRIANA	61	0.00
		BAXTER, ROBIN	61	0.00
		BUI, HAU	61	0.00
		CAMPOS MENDOZA, JANETH	61	0.00
		CAMPOS, JENNY E	61	0.00
		CANTRELL, HUNTER E	61	0.00
		FEW, TAMARA A	61	0.00
		FEW, TRACY M	61	0.00
		GOSS-KUEHN, HERCULES E	61	0.00
		HANSEN, JEAN M	61	0.00
		KAPUSINSKI, ELISSA A	61	0.00
		LARKIN, CAMERON J	61	0.00
		MITCHELL, GRACE K	61	0.00
		MOHAMED, KHADRA M	61	0.00
		ROGNESS, CHASE	61	0.00
		RYKHUS, NICOLETTE A	61	0.00
		SACKETT, ROBYN L	61	0.00
		SCHLEIS, RACHAEL	61	0.00
		TOUSIGNANT, ROBYN E	61	0.00
<b>AVID TUTOR - Total</b>				<b>0.00</b>
CULTURAL LIAISON	DISTRICT-WIDE	ABDULLAHI, SACDIYO J	1	1.00
		ABDULLAHI, SAHRO	1	1.00
		DALE, MARICELA	91	0.00
		DAOUD, HAMDE	1	1.00
		GOODBUFFALO, DOMINIC E	1	1.00
		GRANT, HEIDI A	1	1.00
		KAABIYE, AXMAD	1	1.00
		LOPEZ, MARIA T	1	1.00
		OMAR, ABDULAH	1	1.00
		QUINTANA NUNEZ, MARIANA	1	1.00
		RAMOS, VERONICA	1	1.00
		STAMPLEY, MORGAN	1	1.00
	HIDDEN VALLEY	ONTIVEROS, EDDIECA	1	1.00
<b>CULTURAL LIAISON - Total</b>				<b>12.00</b>
DIR CURRICULUM & INSTRUCTIC	DIAMONDHEAD	STANLEY, STACIE L	1	0.64
<b>DIR CURRICULUM &amp; INSTRUCTION - Total</b>				<b>0.64</b>
EA LEVEL 3	HIDDEN VALLEY	HERNANDEZ, BRENDA	1	0.88
		ONTIVEROS, EDDIECA	91	0.00
		SCHAFFER, CARMEN	1	0.75

## **2018 Revised Budget - Staffing by Budget Unit**

	SKY OAKS	ABTOW, ANAB A	1	1.00
	VISTA VIEW	GUTIERREZ BELTRAN, MARIA L	1	0.81
<b>EA LEVEL 3 - Total</b>				<b>3.44</b>
LANG ARTS TCR	METCALF	THOMAS, JESSICA	3	0.17
<b>LANG ARTS TCR - Total</b>				<b>0.17</b>
SOCIAL WORKER	EDWARD NEILL	STANGL, MELISSA P	1	0.50
	GIDEON POND	KHALIF, ABDULLAHI M	1	0.50
	HARRIET BISHOP	KOCH, REBECCA M	2	0.50
	HIDDEN VALLEY	REICHERT, KRISTEN K	1	0.50
	MW SAVAGE	CHESLA, PATRICK J	1	0.50
	RAHN	KOCH, REBECCA M	1	0.50
	SIOUX TRAIL	FREEBURG, KELLY	2	0.50
	SKY OAKS	KHALIF, ABDULLAHI M	2	0.50
	VISTA VIEW	FREEBURG, KELLY	1	0.50
	WM. BYRNE	MORRISSEY, MICHELLE M	2	0.50
<b>SOCIAL WORKER - Total</b>				<b>5.00</b>
<b>13020 - Total</b>				<b>22.60</b>

### **Budget Unit: 13030**

Description	Location	Employee Name	Seq.	FTE
CONTINUOUS IMPROVEMENT CO	DISTRICT-WIDE	LUTZ, AMANDA J	1	1.00
		PLASCHKO, MARY BETH	1	1.00
		PRANSCHKE, STEPHANIE T	1	1.00
		REID, LISA M	73	0.00
<b>CONTINUOUS IMPROVEMENT COACH - Total</b>				<b>3.00</b>
EA LEVEL 3	ALTERNATIVE HIGH SCHOOL	BUTTLEMAN, OLIVER J	1	0.94
		MIDDLETON, QASHR	1	0.83
	EDWARD NEILL	KRUGER, TARA N	1	0.94
		SPOTT, ANNE B	2	0.44
	GIDEON POND	BARSUG, HUDAYFI M	1	0.94
	HARRIET BISHOP	OSHIRO, KAREN M	1	0.94
	HIDDEN VALLEY	PETERSON, MARGARET A	1	0.94
	MW SAVAGE	FINERAN, KAYLA	1	0.78
	RAHN	WATERS, STACIE	1	0.91
	SIOUX TRAIL	SKAHEN, LORI L	1	0.75
	SKY OAKS	SANTOS, LAURA	1	0.69
	VISTA VIEW	TILLMAN, JACK R	1	0.91
	WM. BYRNE	WENDLING, PAULA L	1	0.94
<b>EA LEVEL 3 - Total</b>				<b>10.92</b>
EA SUPPORT	SIOUX TRAIL	PACKER, RACHEL L	2	0.22
	SKY OAKS	PAUL, TARA	2	0.25
<b>EA SUPPORT - Total</b>				<b>0.47</b>
INTERVENTIONIST	BHS	AAMODT, WILLIAM P	2	0.20
		BANITT, JUSTIN	2	0.40
		FLOYD, KEVIN S	2	0.40
		HARROD, KIMBERLEE N	2	0.60
		HOLCOMBE, SARA J	1	0.40
		MOULSOFF, NORINE L	1	0.60
		NELSON, JEFFREY P	2	0.40
		SCHLAGER, DEREK A	2	0.40
		VOGT, KENDRA M	2	0.60
		EAGLE RIDGE	DAY, MARLYS L	2

## 2018 Revised Budget - Staffing by Budget Unit

		YAGER, AMY LYN	1	0.83
EDWARD NEILL		NIFFENEGGER, KAMALA N	2	0.30
GIDEON POND		FARRELL, TRACY E	1	0.50
		MIRS, LAUREL	2	0.50
HARRIET BISHOP		JORDAN, ALLISON A	1	1.00
HIDDEN VALLEY		HUSSAIN, USMAN S	1	1.00
METCALF		MOHAMED, AYAN	1	1.00
MW SAVAGE		CHAMERLIK, KAREN	1	0.50
NICOLLET		KOLBO, SAMANTHA	1	1.00
RAHN		KEULER, LORI J	1	0.50
		PETERSON, KERI	2	0.50
SIOUX TRAIL		HENDRICKSON, CAROLINE	2	0.50
		STALOCK, SHARRON C	1	0.50
SKY OAKS		RISTEAU, JILL A	2	0.30
		ZEIGLER, SARAH	1	0.70
VISTA VIEW		ORLENKO, CORBIN D	1	0.50
		PODRATZ, ANNE MARIE	2	0.50
WM. BYRNE		KNUTSON, CHRISTINE	1	0.50
<b>INTERVENTIONIST - Total</b>				<b>15.30</b>
KINDERGARTEN TCR	HIDDEN VALLEY	MOALLIN, AISHA A	1	1.00
	SKY OAKS	LINDULA, KATHERINE A	1	1.00
<b>KINDERGARTEN TCR - Total</b>				<b>2.00</b>
SOCIAL WORKER	EDWARD NEILL	STANGL, MELISSA P	2	0.50
	MW SAVAGE	CHESLA, PATRICK J	2	0.50
	WM. BYRNE	MORRISSEY, MICHELLE M	1	0.50
<b>SOCIAL WORKER - Total</b>				<b>1.50</b>
<b>13030 - Total</b>				<b>33.19</b>

### Budget Unit: 14010

Description	Location	Employee Name	Seq.	FTE
DIGITAL LEARNING SPECIALIST	DISTRICT-WIDE	SALMELA, KATHRYN	1	1.00
	EDWARD NEILL	ANDERSON, BJORN RS	1	1.00
	GIDEON POND	ABRAHAMSON, JONATHAN	2	0.13
		ROLLIE, ALEXIS K	1	1.00
	HARRIET BISHOP	RISTEAU, JOSEPH S	1	1.00
	HIDDEN VALLEY	CARLSON, JENNIFER A	1	1.00
	MW SAVAGE	TOFTE, ALEXANDER J	1	1.00
	RAHN	CASSERLY-SMITH, MARY	1	1.00
	SIOUX TRAIL	NESS, KATIE L	1	1.00
	SKY OAKS	CHRISTEN, LISA K.	1	1.00
	VISTA VIEW	ABRAHAMSON, JONATHAN	1	0.88
	WM. BYRNE	WALGENBACH, RACHEL C	1	1.00
<b>DIGITAL LEARNING SPECIALIST - Total</b>				<b>11.00</b>
VIDEO TECH - PER CONTRACT	DISTRICT-WIDE	LUND, TIMOTHY J	31	0.00
<b>VIDEO TECH - PER CONTRACT - Total</b>				<b>0.00</b>
<b>14010 - Total</b>				<b>11.00</b>

### Budget Unit: 14020

Description	Location	Employee Name	Seq.	FTE
DIR TECHNOLOGY	DIAMONDHEAD	JOHNSON, DOUGLAS A	1	1.00
<b>DIR TECHNOLOGY - Total</b>				<b>1.00</b>
INSTRUCTION/TECHNOLOGY COO	DIAMONDHEAD	GORTON, RACHEL	1	1.00
<b>INSTRUCTION/TECHNOLOGY COORD - Total</b>				<b>1.00</b>

## 2018 Revised Budget - Staffing by Budget Unit

TECH SPEC 1	DIAMONDHEAD	ABDIWAHAB, MOHAMED S	1	1.00
		LUND, ELLIOTT J	91	0.00
		RETHLAKE-HOMOLKA, PAM	1	1.00
		WALCZAK, CHERYL M	1	1.00
	DISTRICT-WIDE	VAURIO, SONYA	1	1.00
<b>TECH SPEC 1 - Total</b>				<b>4.00</b>
TECH SPEC 2	DIAMONDHEAD	BLUHM, WILLIAM AE	1	1.00
		HREHA, JUSTIN T	1	1.00
		KOPP, ELIZABETH A	1	1.00
		LUND, ELLIOTT J	1	1.00
		WHIPPLE, ALEC	1	1.00
<b>TECH SPEC 2 - Total</b>				<b>5.00</b>
TECH SPEC 3	DIAMONDHEAD	LUND, TIMOTHY J	1	1.00
<b>TECH SPEC 3 - Total</b>				<b>1.00</b>
TECH SPEC 4	DIAMONDHEAD	WEILER, ROBERT M	1	1.00
<b>TECH SPEC 4 - Total</b>				<b>1.00</b>
<b>14020 - Total</b>				<b>13.00</b>

### Budget Unit: 15020

Description	Location	Employee Name	Seq.	FTE
DIR CURRICULUM & INSTRUCTIC	DIAMONDHEAD	STANLEY, STACIE L	2	0.36
<b>DIR CURRICULUM &amp; INSTRUCTION - Total</b>				<b>0.36</b>
POSA	DIAMONDHEAD	LEAKE, DONALD L	1	1.00
<b>POSA - Total</b>				<b>1.00</b>
SISA COORDINATOR	DIAMONDHEAD	BECQUER, FRANCES	1	1.00
		POPE, ROBERT J	1	1.00
<b>SISA COORDINATOR - Total</b>				<b>2.00</b>
TOSA	DISTRICT-WIDE	NEPSUND, CYNTHIA J	1	1.00
<b>TOSA - Total</b>				<b>1.00</b>
<b>15020 - Total</b>				<b>4.36</b>

### Budget Unit: 15040

Description	Location	Employee Name	Seq.	FTE
CLERICAL	DIAMONDHEAD	CECKA, NANETTE	1	0.75
<b>CLERICAL - Total</b>				<b>0.75</b>
STUDENT INFO/TESTING COORD	DIAMONDHEAD	ERICKSON, CONSTANCE	1	0.50
<b>STUDENT INFO/TESTING COORD - Total</b>				<b>0.50</b>
<b>15040 - Total</b>				<b>1.25</b>

### Budget Unit: 16010

Description	Location	Employee Name	Seq.	FTE
SCHOOL BOARD	DISTRICT-WIDE	CURRIER, DEEDEE C	1	0.00
		LUTH, DANIEL W	1	0.00
		MILLER, ERIC CHARLES	1	0.00
		SCHATZ, DARCY D	1	0.00
		SCHMID, JAMES D	1	0.00
		VANDENBOOM, ROBERT J	1	0.00
<b>SCHOOL BOARD - Total</b>				<b>0.00</b>
SCHOOL BOARD - CHAIR	DISTRICT-WIDE	ALT, ABIGAIL	1	0.00
<b>SCHOOL BOARD - CHAIR - Total</b>				<b>0.00</b>
<b>16010 - Total</b>				<b>0.00</b>

### Budget Unit: 16020

Description	Location	Employee Name	Seq.	FTE
EXEC ADMIN ASSISTANT	DIAMONDHEAD	KENNEY, JAMI M	1	1.00

## 2018 Revised Budget - Staffing by Budget Unit

<b>EXEC ADMIN ASSISTANT - Total</b>				<b>1.00</b>
INTERIM SUPERINTENDENT	DIAMONDHEAD	AMOROSO, CYNTHIA	1	1.00
<b>INTERIM SUPERINTENDENT - Total</b>				<b>1.00</b>
<b>16020 - Total</b>				<b>2.00</b>

### **Budget Unit: 16030**

Description	Location	Employee Name	Seq.	FTE
ASST SUPERINTENDENT	DIAMONDHEAD	WATKINS, DAVID	1	1.00
<b>ASST SUPERINTENDENT - Total</b>				<b>1.00</b>
CLERICAL	DIAMONDHEAD	PARISEAU, MARCIA L	1	0.50
<b>CLERICAL - Total</b>				<b>0.50</b>
<b>16030 - Total</b>				<b>1.50</b>

### **Budget Unit: 16040**

Description	Location	Employee Name	Seq.	FTE
DIR HUMAN RESOURCES	DIAMONDHEAD	SOVINE, STACEY	1	1.00
<b>DIR HUMAN RESOURCES - Total</b>				<b>1.00</b>
HR BENEFITS SPECIALIST	DIAMONDHEAD	LINDBERG, CHARLOTTE	1	1.00
<b>HR BENEFITS SPECIALIST - Total</b>				<b>1.00</b>
HR COORD	DIAMONDHEAD	WEILER, TIFFANY M	1	1.00
<b>HR COORD - Total</b>				<b>1.00</b>
HR EMPLOYMENT SPECIALIST	DIAMONDHEAD	HARRIS, TRUDIE L	1	1.00
<b>HR EMPLOYMENT SPECIALIST - Total</b>				<b>1.00</b>
HR LABOR RELATIONS MGR	DIAMONDHEAD	DEMUTH, JOY S	1	1.00
<b>HR LABOR RELATIONS MGR - Total</b>				<b>1.00</b>
<b>16040 - Total</b>				<b>5.00</b>

### **Budget Unit: 16050**

Description	Location	Employee Name	Seq.	FTE
CLERICAL	DIAMONDHEAD	DITTER, NATALIE L	1	1.00
		JENKINS, LISA T	91	0.00
		KAISERSHOT, STACY L	1	1.00
			91	0.00
		LAQUA, NANCY A	1	1.00
			91	0.00
		LEACH, CHARLOTTE	1	1.00
		PARISEAU, MARCIA L	2	0.50
		VOTH, BETHANY A	1	1.00
		WILSON, MICHELE L	1	1.00
			91	0.00
ZELLMER, JULIE A	1	1.00		
<b>CLERICAL - Total</b>				<b>7.50</b>
DIR ACCOUNTING	DIAMONDHEAD	PIKAL, ROBIN	1	1.00
<b>DIR ACCOUNTING - Total</b>				<b>1.00</b>
DIR BUSINESS	DIAMONDHEAD	RIDER, LISA K	1	1.00
<b>DIR BUSINESS - Total</b>				<b>1.00</b>
PYRL SUPERVISOR	DIAMONDHEAD	ROBASSE, CHRISTINE M	1	1.00
<b>PYRL SUPERVISOR - Total</b>				<b>1.00</b>
<b>16050 - Total</b>				<b>10.50</b>

### **Budget Unit: 16060**

Description	Location	Employee Name	Seq.	FTE
COMMUNICATIONS COORD	DIAMONDHEAD	TINKLENBERG, AARON D	1	1.00
<b>COMMUNICATIONS COORD - Total</b>				<b>1.00</b>

## 2018 Revised Budget - Staffing by Budget Unit

DIR COMMUNICATIONS	DIAMONDHEAD	DUNN, RUTH C	1	1.00
<b>DIR COMMUNICATIONS - Total</b>				<b>1.00</b>
<b>16060 - Total</b>				<b>2.00</b>

### Budget Unit: 16070

Description	Location	Employee Name	Seq.	FTE
CLERICAL	DIAMONDHEAD	CURTIS, MICHELE A	1	1.00
		HARDT, ANNETTE	1	1.00
		LOPEZ, KASSANDRA	1	1.00
		ROMERO, DENISE	1	1.00
		SANDELL, HEIDI	1	1.00
<b>CLERICAL - Total</b>				<b>5.00</b>
INFORMATION SYSTEMS COORD	DIAMONDHEAD	MCCARTHY, BRIGID M	1	1.00
<b>INFORMATION SYSTEMS COORD - Total</b>				<b>1.00</b>
STUDENT INFO/TESTING COORD	DIAMONDHEAD	ERICKSON, CONSTANCE	2	0.50
<b>STUDENT INFO/TESTING COORD - Total</b>				<b>0.50</b>
<b>16070 - Total</b>				<b>6.50</b>

### Budget Unit: 17011

Description	Location	Employee Name	Seq.	FTE	
PRINCIPAL	EDWARD NEILL	VAUGHT, ELIZABETH C	1	1.00	
		GIDEON POND	BELLMONT, CHRISTOPHER	1	1.00
		HARRIET BISHOP	ESSAY, KENNETH P	1	1.00
		HIDDEN VALLEY	BLACK, KRISTINE C	1	1.00
		MW SAVAGE	NEPSUND, JEFF L	1	1.00
		RAHN	BORER, BARBARA	1	1.00
		SIOUX TRAIL	MCPARLAND, SHANNON	1	1.00
		SKY OAKS	BONNEVILLE, JON G	1	1.00
		VISTA VIEW	ROBB, BRADLEY E	1	1.00
		WM. BYRNE	BOMSTA, LYLE J	1	1.00
<b>PRINCIPAL - Total</b>				<b>10.00</b>	
<b>17011 - Total</b>				<b>10.00</b>	

### Budget Unit: 17012

Description	Location	Employee Name	Seq.	FTE	
CLERICAL	EDWARD NEILL	STICKLE, CAROLYN E	1	1.00	
		GIDEON POND	ZIMMERMAN, SYBIL	1	1.00
		HARRIET BISHOP	HINMAN, JENNIFER J	1	1.00
		HIDDEN VALLEY	BERRA, ANGELA M	1	1.00
			OLSON, ELLEN	1	1.00
		MW SAVAGE	BASSETT, AMY	1	0.50
			HREHA, KYLE J	1	1.00
		RAHN	CROSBIE, CYNTHIA	1	1.00
		SIOUX TRAIL	CENCI, BARBARA	1	1.00
		SKY OAKS	PERALTA, NANCY E	1	1.00
		VISTA VIEW	LARSON, DEBORAH M	1	1.00
		WM. BYRNE	MCBRIDE, KRISTEN	1	1.00
		<b>CLERICAL - Total</b>			
<b>17012 - Total</b>				<b>11.50</b>	

### Budget Unit: 17013

Description	Location	Employee Name	Seq.	FTE
EA LEVEL 3	GIDEON POND	NUR, IFRAH H	1	0.25
			3	0.31
			91	0.00

## **2018 Revised Budget - Staffing by Budget Unit**

	RAHN	ARAKAWA, DEBORAH J	2	0.13
	SKY OAKS	SANTOS, LAURA	2	0.25
<b>EA LEVEL 3 - Total</b>				<b>0.94</b>
EA SUPPORT	EDWARD NEILL	HAMMOUD, HANAA	1	0.41
		MCCONNELL, DIANE	1	0.50
		ROCKETT, JOAN	2	0.09
		ROSENBERGER, ROSE M	1	0.50
	GIDEON POND	ABDI, RAHIMA A	1	0.38
			91	0.00
		BUTORAC, MELANIE A	2	0.13
		KUMP, JOLENE	1	0.63
		NUR, IFRAH H	2	0.31
			92	0.00
	HARRIET BISHOP	BECKER, SARAH J	2	0.19
		CHHEN, KUOY L	92	0.00
		FONTANA, PEGGY	1	0.75
		HEEREY, HEATHER	1	0.69
		MCGUIRE, REBECCA L	2	0.19
	HIDDEN VALLEY	VEGA, AMERICA	1	0.34
	MW SAVAGE	BAKER, YVONNE M	1	0.31
		LOWE, MICHELE E	1	0.31
		SAMUEL, LAURIE	1	0.44
	RAHN	JONES, RACHEL C	1	0.69
		MOSLEY, JULIE G	1	0.56
	SIOUX TRAIL	ENGBERG, DENISE G	2	0.25
		PACKER, RACHEL L	1	0.25
		RYAN, PHYLLIS A	1	0.50
		SIDDIQUI, HAJIRA	1	0.38
	SKY OAKS	BERGE, KRISTY K	2	0.25
		HAROON, HAJIR S	1	1.00
	VISTA VIEW	CERMAK, BARBARA L	2	0.25
		GILBERTSON, SHERRY A	1	0.91
		OLSON, DIANE B	2	0.25
	WM. BYRNE	HEINO, KAREN	91	0.00
		HENLE, ANGELA G	1	0.53
		KELJIK, SUSAN B	1	0.53
		Open Position	1	0.28
		VERVAIS, ELIZABETH	1	0.28
<b>EA SUPPORT - Total</b>				<b>13.06</b>
EA TRANS	WM. BYRNE	HENLE, ANGELA G	2	0.38
<b>EA TRANS - Total</b>				<b>0.38</b>
<b>17013 - Total</b>				<b>14.38</b>

### **Budget Unit: 17021**

Description	Location	Employee Name	Seq.	FTE
PRINCIPAL	BHS	HELKE, DAVID M	1	1.00
	EAGLE RIDGE	NESVIG, ERIKA	1	1.00
	METCALF	RONN, KELLY J	1	1.00
	NICOLLET	BRANDNER, RENEE	1	1.00
<b>PRINCIPAL - Total</b>				<b>4.00</b>
PRINCIPAL ASST	BHS	DERDEN, WILLIAM M	1	1.00
		LEPPER, JAY C	1	1.00

## 2018 Revised Budget - Staffing by Budget Unit

		MORRISSETTE, BRUCE P	91	0.00
		POHL, ANGIE J	1	1.00
EAGLE RIDGE		BRASPENICK, CHERIE	1	1.00
METCALF		HEIM, WILLIAM V	1	1.00
NICOLLET		HUGHES, RACHEL J	1	1.00
<b>PRINCIPAL ASST - Total</b>				<b>6.00</b>
<b>17021 - Total</b>				<b>10.00</b>

### Budget Unit: 17022

Description	Location	Employee Name	Seq.	FTE
BURSAR	BHS	BECKERS, CHRISTINE A	1	1.00
<b>BURSAR - Total</b>				<b>1.00</b>
CLERICAL	BHS	DECKER, WENDY	1	1.00
		FRATZKE, JAYNE M	1	1.00
		KATZMAREK, ABIGAIL S	1	1.00
		MCCLELLAN, MELISSA E	1	1.00
		MCGOWAN, RACHEL M	1	1.00
		RIPOLL, SARAH J	1	0.63
		SCHERER, DEBRA M	1	1.00
		THORNTON, JENIFER A	1	1.00
	EAGLE RIDGE	PETROSKEY, KELLIE A	1	1.00
		SCALZO, KRISTIN	1	1.00
		SIMON, LYDIA	1	1.00
	METCALF	BIELECK, DEBORAH D	91	0.00
		MATERNOWSKI, PATRICIA	1	1.00
		PETERSON, LAURA J	1	1.00
		WESTERLUND, DANETTE R	1	1.00
	NICOLLET	DERENDAL, BARBARA L	1	1.00
		MARO, JULIE A	1	1.00
		WICKHAM, LAURA	1	1.00
<b>CLERICAL - Total</b>				<b>16.63</b>
REGISTRAR	BHS	REIHER, PAM	1	1.00
<b>REGISTRAR - Total</b>				<b>1.00</b>
<b>17022 - Total</b>				<b>18.63</b>

### Budget Unit: 17023

Description	Location	Employee Name	Seq.	FTE
EA LEVEL 3	BHS	PULLEY, ERIC D	1	0.50
		VILLE, JUANITA	1	0.88
	EAGLE RIDGE	NEUMAN, JEAN M	1	0.88
		SHAFFER, PENNY L	1	0.88
	METCALF	Open Position	1	0.88
		PETERSON, KIM L	1	0.88
	NICOLLET	MARTINEZ, CHRISTIAN	1	0.88
		PERKINS, TERRI M	1	0.88
<b>EA LEVEL 3 - Total</b>				<b>6.63</b>
<b>17023 - Total</b>				<b>6.63</b>

### Budget Unit: 17025

Description	Location	Employee Name	Seq.	FTE
ELEM ADMIN ASSISTANT	EDWARD NEILL	HERKENHOFF, PATRICIA ANN	51	0.00
		NIFFENEGGER, KAMALA N	51	0.00
	GIDEON POND	LYNCH, MOLLY	51	0.00
		RASMUSSEN, EMILY	51	0.00

## 2018 Revised Budget - Staffing by Budget Unit

	HARRIET BISHOP	CAMPEN, KIMBERLY A.	52	0.00
		JORDAN, ALLISON A	51	0.00
	HIDDEN VALLEY	HUSSAIN, USMAN S	51	0.00
	MW SAVAGE	CHESLA, PATRICK J	51	0.00
	RAHN	SLATTERY, CARA	53	0.00
	SIOUX TRAIL	STALOCK, SHARRON C	51	0.00
	SKY OAKS	DAVIDSON, JESSICA J	51	0.00
	VISTA VIEW	PODRATZ, ANNE MARIE	51	0.00
	WM. BYRNE	MORRISSEY, MICHELLE M	52	0.00
<b>ELEM ADMIN ASSISTANT - Total</b>				<b>0.00</b>
ELEM SAFETY PATROL	EDWARD NEILL	HERKENHOFF, PATRICIA ANN	52	0.00
	GIDEON POND	KING, DANIEL AUSTIN	51	0.00
	HARRIET BISHOP	RISTEAU, JOSEPH S	51	0.00
	HIDDEN VALLEY	SCHWENN, JEFFREY A	51	0.00
	MW SAVAGE	TOFTE, ALEXANDER J	51	0.00
	RAHN	HILL, GARY S	51	0.00
	SIOUX TRAIL	FREDRICKSON, REBECCA	51	0.00
	SKY OAKS	TEIEN, JOAN K	51	0.00
	VISTA VIEW	COUNTERS, ERICA M	51	0.00
		TILLMAN, JACK R	51	0.00
	WM. BYRNE	HENLE, ANGELA G	51	0.00
<b>ELEM SAFETY PATROL - Total</b>				<b>0.00</b>
ELEM SCIENCE FAIR	EDWARD NEILL	ANDERSON, BJORN RS	51	0.00
	GIDEON POND	RAU, JESSICA	51	0.00
	HARRIET BISHOP	STROWBRIDGE, STACI	51	0.00
	HIDDEN VALLEY	NAEF, NATHAN A	51	0.00
	MW SAVAGE	STRAHOTA, SARA J	51	0.00
	RAHN	SLATTERY, CARA	52	0.00
	SIOUX TRAIL	NESS, KATIE L	51	0.00
		STALOCK, SHARRON C	52	0.00
	SKY OAKS	BERG, MATTHEW T	51	0.00
	VISTA VIEW	DEMPSEY, JODI JEAN	51	0.00
	WM. BYRNE	Open Position	51	0.00
<b>ELEM SCIENCE FAIR - Total</b>				<b>0.00</b>
PEER SUPPORT/HELPERS	EAGLE RIDGE	HENDERSON, MICHELLE A	41	0.00
	EDWARD NEILL	TRANBY, BONITA K.	51	0.00
	GIDEON POND	MACNAUGHTON, LAURA	51	0.00
	HARRIET BISHOP	BERRYMAN, ASHLEY A	51	0.00
	HIDDEN VALLEY	REICHERT, KRISTEN K	51	0.00
	METCALF	JEFFERS, LUCRETIA	41	0.00
		MAIDMENT, LORI	41	0.00
	MW SAVAGE	HARVES, NICOLE R	51	0.00
	NICOLLET	FUNCHES, MONIQUE ROY	41	0.00
	RAHN	HARTL, ARAN J	51	0.00
		MCCARTHY, JENNIFER	51	0.00
	SIOUX TRAIL	STALOCK, SHARRON C	53	0.00
	SKY OAKS	ECKERMAN, HANNAH	51	0.00
		ZEIGLER, SARAH	51	0.00
	VISTA VIEW	Open Position	51	0.00
	WM. BYRNE	COOPER, KIRENZA I	51	0.00
<b>PEER SUPPORT/HELPERS - Total</b>				<b>0.00</b>

## 2018 Revised Budget - Staffing by Budget Unit

VOLUNTEER COORDINATOR	BHS	SWANSON, MARGO	31	0.00
	EAGLE RIDGE	PETROSKY, KELLIE A	42	0.00
	EDWARD NEILL	NURMINEN, KARI J	51	0.00
	GIDEON POND	GORMAN, MELANIE	51	0.00
		GRAY, KAREN M	51	0.00
	HARRIET BISHOP	DESHAW, JENNIFER R	51	0.00
	HIDDEN VALLEY	BERRA, ANGELA M	51	0.00
	METCALF	MAIDMENT, LORI	43	0.00
	MW SAVAGE	VOIGT, PAMELA M	51	0.00
	NICOLLET	WICKHAM, LAURA	41	0.00
	RAHN	CHRISTMAN, AMBER J	51	0.00
	SIOUX TRAIL	ENGBERG, DENISE G	52	0.00
	SKY OAKS	ACHENBACH, AMY J	51	0.00
	VISTA VIEW	ORLENKO, CORBIN D	51	0.00
	WM. BYRNE	MORRISSEY, MICHELLE M	51	0.00
		RAGATZ, ELIZABETH C	51	0.00
<b>VOLUNTEER COORDINATOR - Total</b>				<b>0.00</b>
WEBMASTER	BHS	LAKE, LISA L	31	0.00
<b>WEBMASTER - Total</b>				<b>0.00</b>
<b>17025 - Total</b>				<b>0.00</b>

### Budget Unit: 17010

Description	Location	Employee Name	FTE	
VOLUNTARY PRE K	GIDEON POND	SMITH-LOSSIAH, SHARON KAY	0.75	
	HIDDEN VALLEY	MONNENS, SELENA	0.68	
		RIVERS, JESSICA	0.70	
	VISTA VIEW	FICK, LILA	0.62	
		ROTTJAKOB, RONDA	0.70	
	SKY OAKS	MOHAMUD, FAUZIA	0.67	
<b>VOLUNTARY PRE K - Total</b>				<b>4.12</b>
<b>17010 - Total</b>				<b>4.12</b>

### Budget Unit: 18010

Description	Location	Employee Name	Seq.	FTE
EA TRANS	EDWARD NEILL	ROSENBERGER, ROSE M	2	0.38
	GIDEON POND	KUMP, JOLENE	2	0.38
	HARRIET BISHOP	CHHEN, KUOY L	91	0.00
		MCGUIRE, REBECCA L	1	0.38
	HIDDEN VALLEY	Open Position	1	0.25
		SUGULE, KAHO	1	0.38
	MW SAVAGE	SAMUEL, LAURIE	2	0.38
	RAHN	MOSLEY, JULIE G	2	0.38
	SIOUX TRAIL	SIDDIQUI, HAJIRA	2	0.38
	SKY OAKS	PAUL, TARA	1	0.38
	VISTA VIEW	OLSON, DIANE B	1	0.38
<b>EA TRANS - Total</b>				<b>3.63</b>
<b>18010 - Total</b>				<b>3.63</b>

### Budget Unit: 19010

Description	Location	Employee Name	Seq.	FTE
CUSTODIAN	ALTERNATIVE HIGH SCHOOL	DIMBERIO, ROBBIE	1	1.00
		LOPEZ, JOSEPH D	1	0.50

**2018 Revised Budget - Staffing by Budget Unit**

	PRESS, MARY	1	1.00
BHS	ALVARADO, ANGEL	1	1.00
	ANDERSON, SEAN M	1	1.00
	BOGUE, DREW A	91	0.00
	DAVILA, GUILLERMO D	1	1.00
	FITZGERALD, ELIZABETH	1	1.00
	FOSTER, KENT M	1	1.00
	GOMEZ, OSCAR A	1	1.00
	GRAUPMANN, DAVID A	1	1.00
	JOHNSON, BRIAN J	1	1.00
	JOHNSON, MARK E	1	1.00
	JOHNSON, NICHOLAS A	1	1.00
	LAKE, DAVID	1	1.00
	LUNDBERG-SCHMIDT, PAMELA M	1	1.00
	MATYKIEWICZ, BRANDON J	1	1.00
	OHLHAUSER, CONNOR C	1	1.00
	ORELLANA, LAURA I	1	1.00
	SCHMIDT, BRENT G	1	1.00
	SCHWANKE, CRAIG A	1	1.00
	WICK, DARRYL	1	1.00
DIAMONDHEAD	BERG, HAROLD J	1	1.00
	CARLSON, KEITH A	1	1.00
	GREINER, STEVE	1	1.00
	KIEHN, JEAN M	1	1.00
	THURBER, LAURIE	1	1.00
DISTRICT-WIDE	WENDORF, ERIC S	1	1.00
	WOLLERSHEIM, CHRISTIAN P	1	1.00
EAGLE RIDGE	GORZYCKI, MARK	1	1.00
	JOHNSON, GLENN A.	1	1.00
	LY, TY V	1	1.00
	MCDONALD, DAVID	1	1.00
	SAHLI, TERESEA	1	1.00
	SCHALLENBERG, CATHERINE	91	0.00
EDWARD NEILL	ALVARADO, MARY	1	1.00
	REIMERS, JAMES F	1	1.00
	STRAUSS, LEVI	2	0.50
	VERTEIN, JAMES	1	0.50
GIDEON POND	STRAUSS, LEVI	1	0.50
	TOELLER, JOHN F.	1	1.00
	VERTEIN, JAMES	2	0.50
	WOLFRAM, MICHAEL	1	1.00
HARRIET BISHOP	ALVARADO ROBLES, LUIS	2	0.50
	CARLSON, SANDRA K	1	1.00
	MARTINEZ, ROBERT V	1	1.00
HIDDEN VALLEY	FROST, MICHAEL	91	0.00
	NELSON, KIRK A	1	1.00
	SULLIVAN, GERALDINE E	1	1.00
METCALF	ABBOTT, MARK M	1	1.00

**2018 Revised Budget - Staffing by Budget Unit**

		ANDERSON, CHRISTOPHER	1	1.00
		KREPS, RODNEY V	1	1.00
		LEON, STEVEN F	1	1.00
		SAHLI, JONATHAN C	1	1.00
MW SAVAGE		ALVARADO ROBLES, LUIS	1	0.50
		FREDERICKSON, NORMAN D	1	1.00
		MILLS, DEREK R	2	0.38
		ROBASSE, CHARLES W	1	1.00
NICOLLET		GIBBONS, PATRICK M	1	1.00
		JENSEN, BRYAN J	1	1.00
		MARCHESSAULT, PATRICK	1	1.00
		O'LEARY, DANIEL L	1	1.00
		TESKE, JEFFREY J	1	1.00
RAHN		GILBERTSON, DALE	1	1.00
		NEEDHAM, TIMOTHY	1	1.00
		SWAIN, SHAWN L	2	0.50
SIOUX TRAIL		GLENDE, MARK	1	1.00
		JONES, GARY A	1	1.00
		LOPEZ, JOSEPH D	2	0.50
SKY OAKS		KAISERSHOT, TROY M	1	1.00
		KINYON, TERRY R	1	1.00
		OLDER, GLEN R	1	1.00
		STRAUSS, FOREST	1	1.00
VISTA VIEW		HRIMNAK, JOSEPH MICHAEL	1	1.00
		MILLS, DEREK R	1	0.63
		MORALES, MANUELA	1	1.00
WM. BYRNE		HENDERSON, SEAN M	1	1.00
		SATHER, DEREK D	1	1.00
		SWAIN, SHAWN L	1	0.50
<b>CUSTODIAN - Total</b>				<b>70.00</b>
DIR OF OPERATIONS	DIAMONDHEAD	SIMON, GLENN D.	2	0.40
<b>DIR OF OPERATIONS - Total</b>				<b>0.40</b>
OPS SUPERVISOR	DISTRICT-WIDE	SHAWBACK JR, ARTHUR	1	1.00
		WURDEMAN, SCOTT	1	1.00
		ZEIMET, EDWARD	1	1.00
<b>OPS SUPERVISOR - Total</b>				<b>3.00</b>

<b>19010 - Total</b>	<b>73.40</b>
----------------------	--------------

**Budget Unit: 19020**

Description	Location	Employee Name	Seq.	FTE
CUSTODIAN	DISTRICT-WIDE	ANDERSON, JOHN CHARLES	1	1.00
		CHANTARA, THOMAS KHAMSING	2	0.50
		DYKSTRA, BRYAN G.	1	1.00
		HADAC, WILLIAM	1	1.00
		JOHNSON, MICHAEL A	1	1.00
		POWERS, DANIEL	1	1.00
		POWERS, SCOTT D	1	1.00

## 2018 Revised Budget - Staffing by Budget Unit

		SCHUUR, MYRON G	1	1.00
		VENDEL, MATTHEW M	1	1.00
		WENDORF, GREGORY	92	0.00
<b>CUSTODIAN - Total</b>				<b>8.50</b>
HOURLY - SEASONAL	DISTRICT-WIDE	BRINGGOLD, JAKE	61	0.00
		FALTEISEK, KEVIN J	61	0.00
		LORSUNG, CONOR G	61	0.00
		NELSON, SETH M	61	0.00
		STRAUSS, LEVI	61	0.00
		TICHY, DAVID P	61	0.00
		WICK, KALEB	61	0.00
<b>HOURLY - SEASONAL - Total</b>				<b>0.00</b>
SUMMER WAREHOUSE	DISTRICT-WIDE	MUIR, KELLY S	61	0.00
<b>SUMMER WAREHOUSE - Total</b>				<b>0.00</b>
<b>19020 - Total</b>				<b>8.50</b>

### **Budget Unit: 19030**

Description	Location	Employee Name	Seq.	FTE
CLERICAL	DIAMONDHEAD	THOMPSON, SUSAN M	1	1.00
<b>CLERICAL - Total</b>				<b>1.00</b>
DIR OF OPERATIONS	DIAMONDHEAD	SIMON, GLENN D.	1	0.60
<b>DIR OF OPERATIONS - Total</b>				<b>0.60</b>
<b>19030 - Total</b>				<b>1.60</b>

### **Budget Unit: 19050**

Description	Location	Employee Name	Seq.	FTE
CUSTODIAN	DISTRICT-WIDE	CHANTARA, THOMAS KHAM SING	1	0.50
		HARTMAN, THOMAS P	1	1.00
		WENDORF, GREGORY	91	0.00
<b>CUSTODIAN - Total</b>				<b>1.50</b>
<b>19050 - Total</b>				<b>1.50</b>

### **Budget Unit: 20030**

Description	Location	Employee Name	Seq.	FTE
EA LEVEL 3	BHS	DOVE, BETTY ANN	1	0.88
		KINSELLA, JOSEPH	1	0.88
		LORIG, DIANE	1	0.88
		ROBLES, MICHELLE R	1	0.44
			2	0.44
		WALLS, ELI	1	0.88
	METCALF	ROBERTSON, PAULA	1	0.88
<b>EA LEVEL 3 - Total</b>				<b>5.25</b>
<b>20030 - Total</b>				<b>5.25</b>

### **Budget Unit: 21150**

Description	Location	Employee Name	Seq.	FTE
SMART CHOICES COORD	DIAMONDHEAD	ANDERSON, JAYME S	61	0.00
<b>SMART CHOICES COORD - Total</b>				<b>0.00</b>
<b>21150 - Total</b>				<b>0.00</b>