

BOE Meeting Template
Monday, January 13, 2014 7:00 PM

Mabelle Avery Middle School District Offices Board Room, 4 Vision Boulevard, Somers, CT 06071

1. CALL TO ORDER
2. PLEDGE OF ALLEGIANCE
3. APPROVAL OF MINUTES 2
4. AUDIENCE TO CITIZENS/STAFF/STUDENTS 5
 1. Curriculum Presentations on Math and World Language
Kathleen Pezza, Director of Curriculum, will do a presentation on Math and World Language curricula. She will be available to answer any questions Board members may have.
5. CORRESPONDENCE 25
 1. 2013-2014 Educator Certification Compliance Report
Dr. Suffredini, Superintendent of Schools, has provided a letter from the State regarding compliance.
6. OPPORTUNITY TO ADD/DELETE AGENDA ITEMS
7. CONSENT AGENDA 26
 1. Approval of Bills
8. NEW BUSINESS 34
 1. 2014-2015 School Calendar
SEA has been notified about modifications to the 2014-2015 School Calendar draft.
9. OLD BUSINESS
 1. Signing of the SEA/BOE 2014-2017 New Contract
Designated members of the BOE and SEA will sign the new 2014-2017 SEA/BOE Contract.
10. ADMINISTRATIVE REPORTS 35
 1. 2014-2015 Budget Presentation
The 2014-2015 Budget will be presented for discussion.
11. COMMITTEE REPORTS
 1. Budget
 2. Curriculum
 3. Policy
 4. Salary & Negotiations
 5. Planning
 6. Other Committees
12. OTHER
 1. EXECUTIVE SESSION - SCHOOL SECURITY UPDATE
To update the Board of Education on Somers District School Security.
 2. EXECUTIVE SESSION - SUPERINTENDENT'S MID-YEAR EVALUATION
Review of Superintendent's Mid-Year Evaluation.
13. ADJOURNMENT

SOMERS BOARD OF EDUCATION

1 Vision Boulevard

Somers, CT 06071

www.somers.k12.ct.us

MINUTES OF THE MEETING – December 18, 2013

Members Present: D.Palmer, B.Devlin, A.Kirkpatrick, M.Rockett, K.McLellan, S.Bollinger, M.Marquardt
Members Absent: J. Formeister, R. Lees
Administrators Present: M.Suffredini, B. Boutwell
Staff Present: None
Citizens Present: None
Students Present: None
Others None

1.0 CALL TO ORDER

The special meeting of the Board of Education was called to order at 6:15 p.m. by Chairman David Palmer in the Mabelle B. Avery Middle School Board of Education meeting room.

2.0 BOARD VOTE TO RATIFY SEA CONTRACT

MOTION was made (S. Bollinger) and SECONDED (M. Marquardt) that the Board vote to accept the new three-year SEA Contract as presented by Salary and Negotiations Sub-Committee Chairman Bruce Devlin. PASSED 7-0

3.0 ADJOURNMENT

It was MOVED (B. Devlin) SECONDED (M. Marquardt) to adjourn the special meeting of the Board of Education at 6:19 p.m. PASSED 7-0

Respectfully submitted for,

Rick Lees, Jr., Secretary by Dr. Maynard Suffredini, Jr., Superintendent

These minutes are not official until approved at a subsequent meeting.

SOMERS BOARD OF EDUCATION

1 Vision Boulevard

Somers, CT 06071

www.somers.k12.ct.us

MINUTES OF THE MEETING – December 9, 2013

Members Present: D.Palmer, J.Formeister(Arrived at 7:04 p.m.), R.Lees, M.Rockett, A.Kirkpatrick, K.McLellan, B.Devlin, S.Bollinger(Arrived at 7:06 p.m.)
M.Marquardt (Left at 8:12 p.m.)

Members Absent:

Administrators Present: M.Suffredini, K.Pezza, B.Boutwell, R.Kapner, R.Wilson, D.Messina

Staff Present: L.Reilly, J.Kunzelman

Citizens Present: B.Capuano, B.Schmidt

Students Present:

Others:

1.0 CALL TO ORDER

The regular meeting of the Board of Education was called to order at 7:00 p.m. by Chairman Palmer in the Mabelle B. Avery Middle School Board of Education meeting room.

2.0 PLEDGE OF ALLEGIANCE

3.0 APPROVAL OF MINUTES

November 25, 2013 – It was MOVED (R.Lees) SECONDED (M.Rockett) to approve the November 25, 2013 Board of Education meeting minutes as presented. PASSED 7-0

4.0 AUDIENCE TO CITIZENS/STAFF/STUDENTS

5.0 CORRESPONDENCE

6.0 OPPORTUNITY TO ADD/DELETE AGENDA ITEMS

7.0 CONSENT AGENDA

7.1 Approval of Bills 12/5/13 (\$363,638.27)

It was MOVED (B.Devlin) SECONDED (R.Lees) to approve the 12/5/13 Bills in the amount of \$363,638.27 as presented. PASSED 7-0

8.0 NEW BUSINESS

8.1 Superintendent's Mid-Year Evaluation

Mid-Year Evaluation forms were sent to BOE members to complete and respond back to the BOE Chairman.

9.0 OLD BUSINESS

10.0 ADMINISTRATIVE REPORTS

10.1 iPad Program Updates

Mr. Rob Wilson, Director of Technology and Information Systems, gave the Board an update on the status of the District's iPad program. Talks continue with Apple exploring financing and leasing options to provide every student in the District with an iPad by next year. Fifth grade teacher Mrs. Lisa Reilly and seventh grade teacher Mrs. Julie Kunzelman

gave demonstrations of the ways they have incorporated the iPads into their classroom lesson plans. All three were available to answer any questions from BOE members.

11.0 COMMITTEE REPORTS

Minutes will be taken at all subcommittee meetings.

11.1 Budget – This year is tracking well. Budget discussions will be on the agenda in January.

11.2 Curriculum

11.3 Policy – New notebooks are ready.

11.4 Salary & Negotiations – Mediation on Tuesday night.

11.5 Planning Committee

11.6 Other Committees

12.0 OTHER

Discussion of new committee assignments

13.0 ADJOURNMENT

It was MOVED (B.Devlin) SECONDED (R.Lees) to adjourn the regular meeting of the Board of Education at 8:30 p.m. PASSED 8-0

Respectfully submitted,

Rick Lees, Jr., Secretary

These minutes are not official until approved at a subsequent meeting.

Mathematics

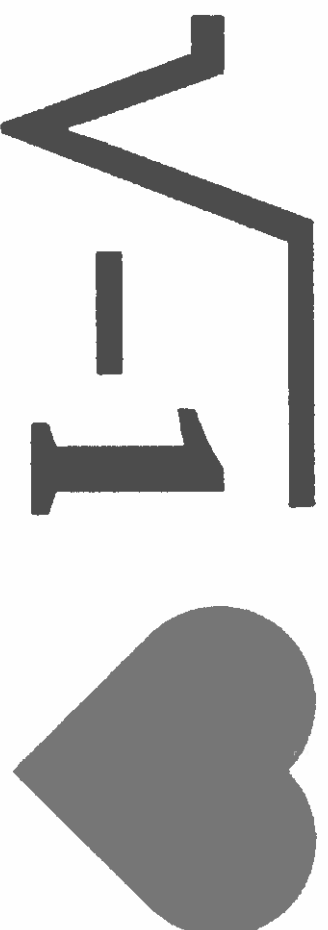

MATH

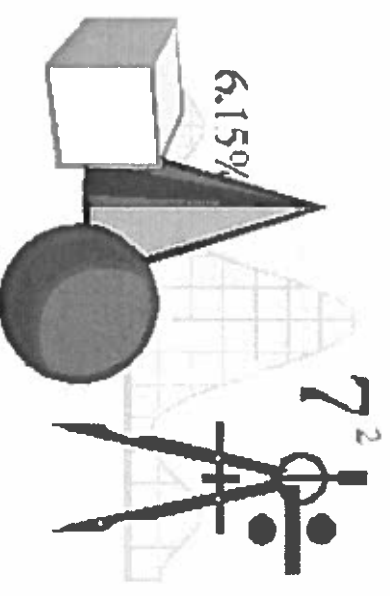

6.15%

7^2

Program Overview

- District math teachers are currently rewriting the K-12 curriculum to ensure that it matches the new Common Core State Standards in Mathematics.
- This year, IXL is being used in grades K-12 to provide students with additional opportunities to practice problem solving in an online environment.

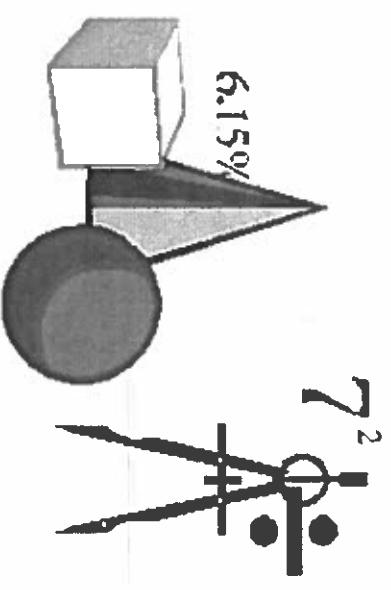

Mathematics at SES

- This year is the fifth year of using the Addison-Wesley Scott Foresman (AWSF) series in grades K-2 and the sixth year for grades 3-5. This book is not well aligned to the CCSS and teachers are currently investigating alternatives. We are piloting Envisions Math at several grade levels.

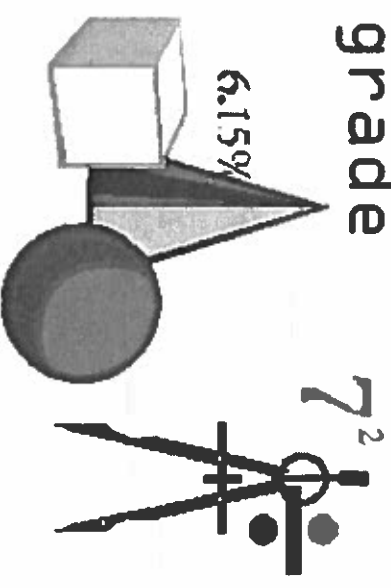

Mathematics at SES

- IXL usage information as of January 8, 2014:
 - 1,429 hours of practice completed
 - 190,742 problems attempted
 - 612 skills practiced
 - 3,831 medals earned (medals are earned by demonstrating mastery of a skill)
 - 84% of students using

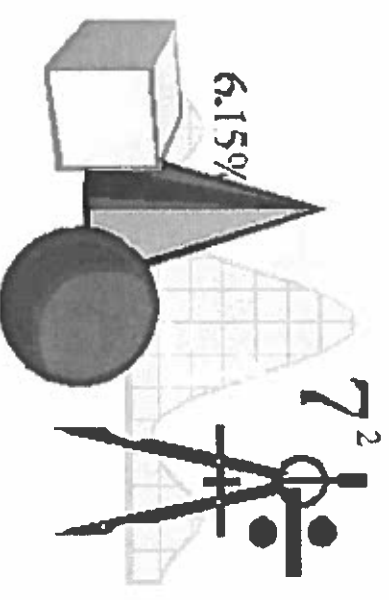

Mathematics at MBA

- At the sixth grade level, all students take a course in general math.
- In seventh grade, some students study Pre-Algebra, while others continue with the more generalized math course.
- When students reach 8th grade, they either take Pre-Algebra or a high school level Algebra I class.

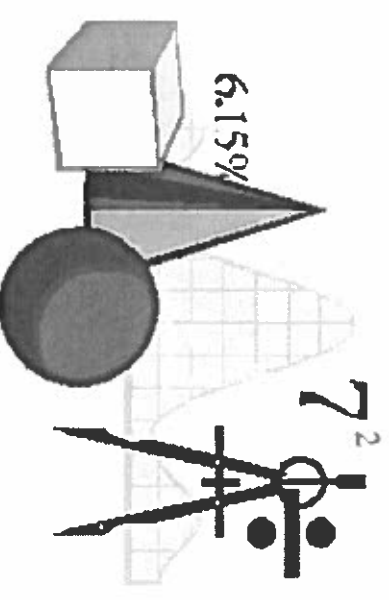

Mathematics at MBA

- IXL usage information as of January 8, 2014:
 - 2,519 hours of practice completed
 - 256,220 problems attempted
 - 412 skills practiced
 - 1,753 medals earned (medals are earned by demonstrating mastery of a skill)
 - 97% of students using

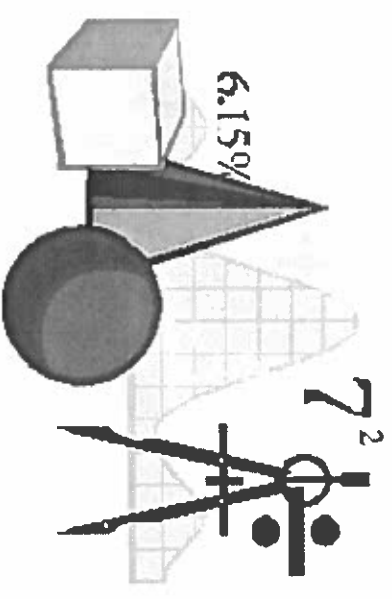

Mathematics at SHS

- Students at the SHS have the opportunity to study Algebra, Geometry, Trigonometry, Calculus, Probability and Statistics and Consumer Math.
- Courses are offered at both the college preparatory and honors level.
- Currently, there are also two AP math classes: AB Calculus and Probability and Statistics

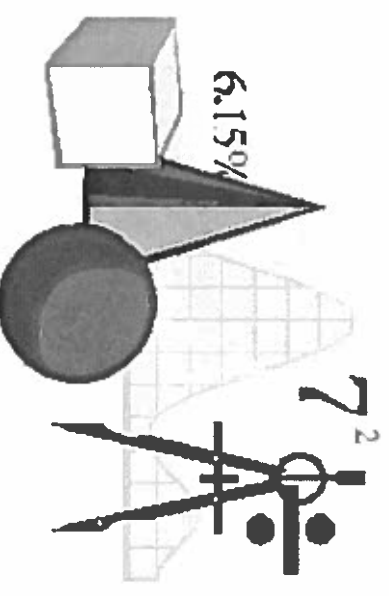

Mathematics at SHS

- IXL usage information as of January 8, 2014:
 - 389 hours of practice completed
 - 40,568 problems attempted
 - 138 skills practiced
 - 99 medals earned (medals are earned by demonstrating mastery of a skill)
 - 17% of students using

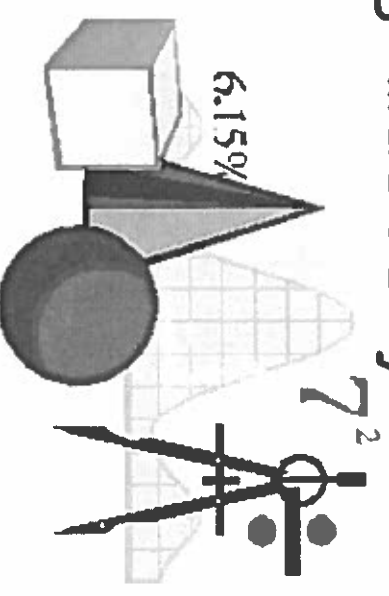

Mathematics at SHS

- In addition to the academic course of study, SHS also has clubs for math oriented students
 - FBLA
 - JETS
 - Math Team
- Technology integration at SHS has increased as teachers have started integrating IXL into the curriculum and will continue as we move into next year.

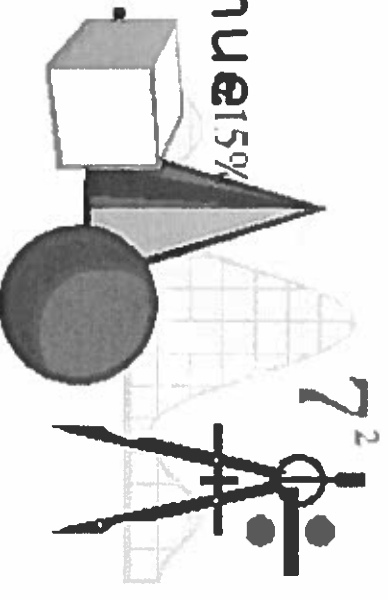

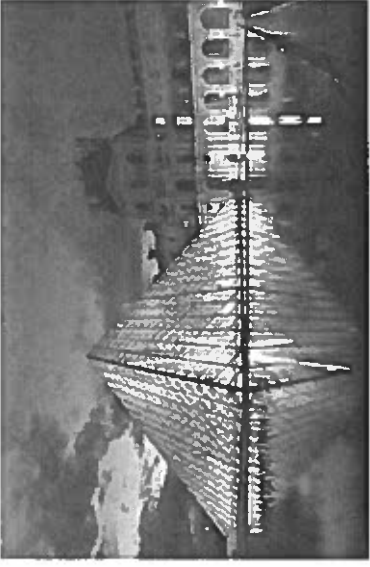
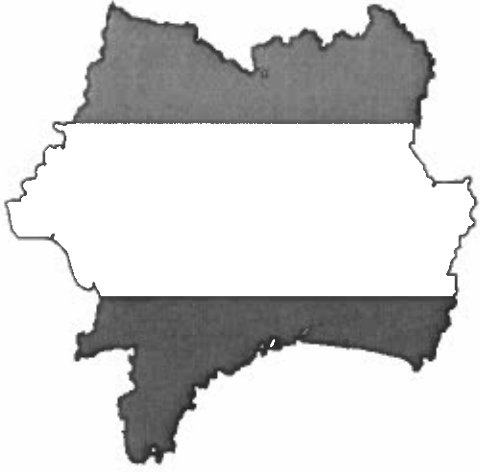
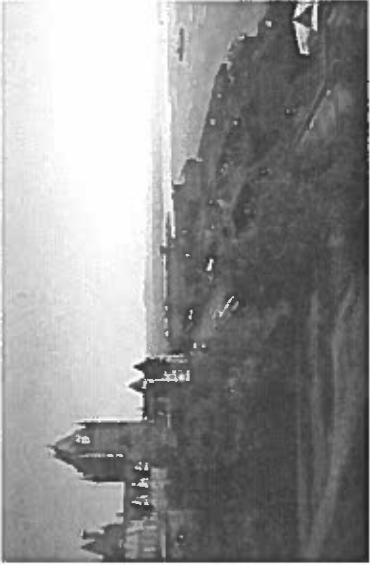

World Language

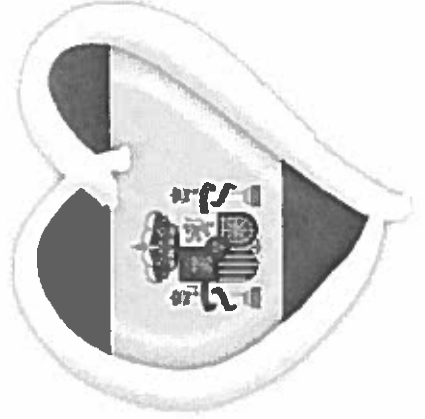
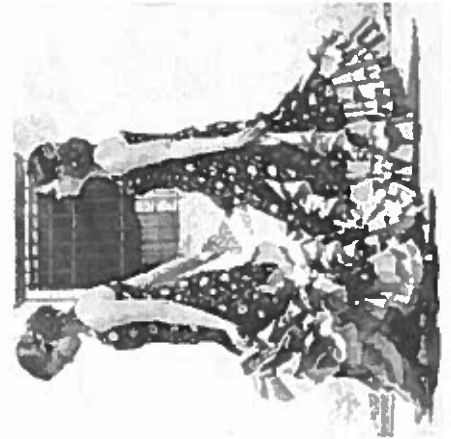

World Language Overview



- Students in all three schools have the opportunity to learn about world languages and cultures.
- As a result of their 1-12 experience, students are exposed to introductory instruction in both French and Spanish.
- The current World Language curriculum was completed in 2009; and now, the teachers are working to integrate the CCSS for literacy into the World Language curriculum.

World Language at SES



- Students start their study of Spanish in grade 1 and receive 55 minutes of instruction once each week in grades 1-5.
- At the elementary level, students learn basic greetings and vocabulary related to colors, numbers, family, pets, clothing, weather, as well as age appropriate Spanish and Hispanic cultural concepts.

World Language at SES



- In grade 2, students participate in the “Journey North” project through Annenburg media, in which they make and send paper Butterflies to Mexico. In the spring, they receive back butterflies from other parts of the country and the World.
- In Grade 3, students use the internet to collect climate and weather data in South America and compare it to climate and weather data in Somers.
- In Grades 4 and 5 students write letters to pen pals in Spain.

World Language at MBA



- In 6th Grade, students are introduced to French for the first time.
- They learn basic French vocabulary with an emphasis on speaking and listening skills.
- Interdisciplinary connections with Social Studies are common as students study the geography of the French speaking world.

World Language at MBA

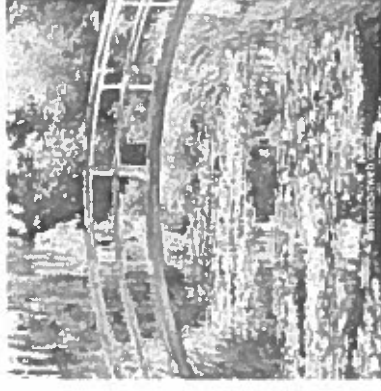

- Students in 7th grade take one semester of French and one semester of Spanish.
- At this grade level, students build off of the basic vocabulary they've acquired in either elementary school or sixth grade and prepare for high school level language instruction.
- Teachers use technology including SMART Boards and apps like Showbie, Quizlet, Educations and Evernote.

World Language at MBA

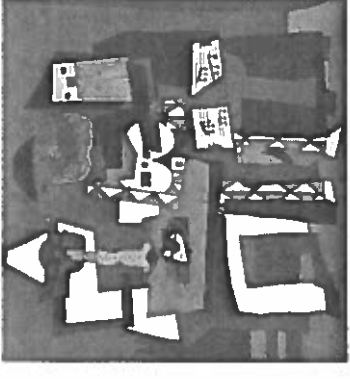

- In 8th grade students select the language that they would like to study at a high school level.
- Strong language students complete a full year, high school level course and are eligible to take Spanish or French 2 as freshmen.
- Students who need to move slower take French or Spanish 1A, which is equivalent to half a year of high school level study. As freshman, they complete that first year of study in French or Spanish 1B and then move onto French or Spanish 2B as sophomores.

World Language SHS



- The French and Spanish programs at the high school have five levels of study.
- As they progress through the high school World Language program, they move from acquiring a basic understanding of the language to a study of literature and the development of speaking proficiency.
- Student who complete French 5 or Spanish 5 have the option of taking the AP French or AP Spanish exam, even though French 5 and Spanish 5 are not explicitly AP courses.

World Language SHS

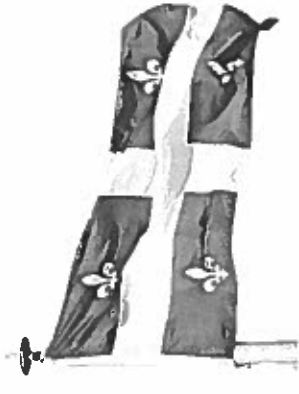

- World Language teachers at the High school use tools like Skype to provide students with an opportunity to talk to teenagers in French and Spanish speaking countries.
- They also link students to on-line broadcasts in the target language, work with students through Google.docs, and incorporate a variety of apps into their language instruction.
- For the last few years, students in French 4 and 5 have had the opportunity to travel to Quebec and use their French skills in a French speaking environment, which Spanish students were able to go to Spain.



STATE OF CONNECTICUT
STATE DEPARTMENT OF EDUCATION



January 6, 2014

Dr. Maynard Suffredini, Jr.
Somers Public Schools (129)
47 Ninth District Rd
Somers, CT 06071

Dear Dr. Suffredini:

I am writing in regards to the 2013-2014 school year Educator Certification Compliance Report.

We have received your compliance report. Based on the corrections noted, I am pleased to inform you that your school district is in full compliance with Connecticut General Statutes, Sec. 10-145 (a) (*p. 210, Connecticut Education Laws as of January 1, 2013*):

No teacher, supervisor, administrator, special service staff member or school superintendent shall be employed in any of the schools of any local or regional board of education unless such person possesses an appropriate state certificate, nor shall any such person be entitled to any salary unless such person can produce such certificate dated previous to or the first day of employment...

If you have any questions regarding the Educator Certification Compliance Report, please contact Julianne Frost, Compliance Coordinator at (860) 713-6770 or email julianne.frost@ct.gov.

Thank you for your continued cooperation with providing high quality teachers for all children in the state.

Sincerely,

A handwritten signature in cursive script that reads "Nancy L. Pugliese".

Nancy L. Pugliese, J.D. Chief
Bureau of Educator Standards and Certification

NLP:jf

Somers Board of Education General Budget Treasury Warrant

Report # 26680

Check Batch: 9513
 Check Header: (N / A)
 Check Numbers: (First) - (Last)
 Check Dates: (Earliest) - (Latest)
 Cash Account Numbers: (First) - (Last)
 Bank Account Code: (N/A)
 Check Authorization Code: AP GB
 Minimum Check Amount: \$0.00
 Sorted By:
 Include Payable Information: No
 Include Payable Dist Information: No
 Include Authorization Information: Yes

Batch #	Check #	Check Date	Vendor Code	Vendor Name	Electronic Amount	Check Amount
---------	---------	------------	-------------	-------------	----------------------	-----------------

Approved by:  **Date:** 1/9/14

 William B. Boutwell, Director of Business Services

9513	7731	01/13/2014	V01035	A W Gifford, Inc.	0.00	213.60
	7732	01/13/2014	V60849	Acres Power Equipment Co	0.00	195.15
	7733	01/13/2014	V02129	Alarm New England LLC	0.00	521.19
	7734	01/13/2014	V52404	Allstate Fire Equipment	0.00	785.00
	7735	01/13/2014	V60790	Alternative Access Assistive Technology	0.00	702.50
	7736	01/13/2014	V52670	Amazon	0.00	2,360.38
	7738	01/13/2014	V60041	Anthem BCBS	0.00	189,732.32
	7739	01/13/2014	V60040	Anthem Life Insurance Company	0.00	2,374.43
	7740	01/13/2014	V02141	Apple Inc.	0.00	2,191.00
	7741	01/13/2014	V00555	AT&T	0.00	959.42
	7742	01/13/2014	V54164	Auto Tek LLC	0.00	895.84
	7743	01/13/2014	V00884	Avery Septic Service	0.00	550.00
	7744	01/13/2014	V51604	Awards & More	0.00	138.05
	7745	01/13/2014	V60123	B&H Photo	0.00	294.00
	7746	01/13/2014	E00450	Bergamini, Lisa	0.00	37.29
	7747	01/13/2014	V02351	Brian's Tool Sales	0.00	4,112.00
	7748	01/13/2014	V00121	CABE	0.00	127.46
	7749	01/13/2014	V00052	CAS Inc.	0.00	600.00
	7750	01/13/2014	V51942	CBS	0.00	5,434.85
	7751	01/13/2014	V60529	Chalkboard, The	0.00	34.15

Somers Board of Education General Budget Treasury Warrant

Report # 26680

Batch #	Check #	Check Date	Vendor Code	Vendor Name	Electronic Amount	Check Amount
	7752	01/13/2014	V53390	CIRMA	0.00	632.00
	7753	01/13/2014	V00159	Connecticut Light & Power	0.00	19,494.03
	7754	01/13/2014	V53280	Collins Sports Medicine	0.00	348.08
	7755	01/13/2014	V60740	Connecticut Piano Company, The	0.00	300.00
	7756	01/13/2014	V02474	Connecticut Radio, Inc	0.00	120.00
	7757	01/13/2014	V60556	Connecticut Valley Artesian Well Co., In	0.00	234.21
	7758	01/13/2014	V02198	The Connecticut Water Company	0.00	5,421.80
	7759	01/13/2014	V60205	CPI Qualified Plan Consultants, Inc.	0.00	28.00
	7760	01/13/2014	V00204	CREC	0.00	943.00
	7761	01/13/2014	V60638	Darlene Hardwood FLG Co., Inc	0.00	350.00
	7762	01/13/2014	V60709	DBS Energy Inc.	0.00	541.06
	7763	01/13/2014	V60089	Dime Oil Company LLC	0.00	22,224.11
	7764	01/13/2014	V00243	Discount Magazine Subscription Service,	0.00	155.75
	7765	01/13/2014	E00096	Duffy, Margaret	0.00	114.00
	7766	01/13/2014	V60252	EAI Education	0.00	376.16
	7767	01/13/2014	V60918	eBackpack, Inc	0.00	250.00
	7768	01/13/2014	V60884	Edward Tyler	0.00	140.00
	7769	01/13/2014	V00605	Electrical Wholesalers	0.00	44.36
	7770	01/13/2014	V02309	ETA hand2mind	0.00	178.21
	7771	01/13/2014	V60919	Fire Retardant Coatings of Texas, LLC	0.00	65.02
	7772	01/13/2014	V60914	FireHouse Learning, LLC	0.00	304.00
	7773	01/13/2014	V54168	First Student, Inc	0.00	63,495.62
	7774	01/13/2014	V02186	Flinn Scientific, Inc.	0.00	612.29
	7775	01/13/2014	V00314	Follett Library Resources	0.00	286.46
	7776	01/13/2014	E00257	Ford, Linda	0.00	17.16
	7777	01/13/2014	V60912	Fotronic Corporation	0.00	264.00
	7778	01/13/2014	V60920	Global Equipment Company	0.00	128.69
	7779	01/13/2014	V60035	Google, Inc.	0.00	20.60
	7780	01/13/2014	V54081	Graduate Pest Solutions, Inc.	0.00	158.00
	7781	01/13/2014	V00511	Grainger	0.00	124.56
	7782	01/13/2014	V60804	Granite City Electric Supply	0.00	862.08
	7783	01/13/2014	V60924	Grimaldi's Carpet Cleaning	0.00	460.00
	7784	01/13/2014	V53439	Group Dynamic	0.00	66.60
	7785	01/13/2014	V53511	Hall, Robert	0.00	177.50
	7786	01/13/2014	V00407	Hartford Courant	0.00	101.91
	7787	01/13/2014	V51232	Hartford Hospital	0.00	5,890.00
	7788	01/13/2014	V00639	HB Communications Inc.	0.00	300.00

Somers Board of Education General Budget Treasury Warrant

Batch #	Check #	Check Date	Vendor Code	Vendor Name	Electronic Amount	Check Amount
	7789	01/13/2014	V53228	Herff Jones Inc.	0.00	259.41
	7790	01/13/2014	V60090	High Grade Gas Service, Inc	0.00	3,405.21
	7791	01/13/2014	V54063	HSABank	0.00	5.00
	7792	01/13/2014	V60923	Hugh's Mechanical Equipment, LLC	0.00	350.00
	7793	01/13/2014	E00689	Hull, Bryan	0.00	99.75
	7794	01/13/2014	V60626	Institute For Educational Development	0.00	229.00
	7795	01/13/2014	V52848	Intensive Education Academy, Inc.	0.00	3,981.90
	7796	01/13/2014	V60043	IVEY Industries	0.00	145.97
	7797	01/13/2014	E00156	Jennings, Diane	0.00	46.95
	7798	01/13/2014	V00048	Johnson Controls	0.00	322.88
	7799	01/13/2014	V02625	K & S Distributors	0.00	638.74
	7800	01/13/2014	V00665	Kelly-Fradet Lumber	0.00	158.35
	7801	01/13/2014	V60527	Kloter Farms Inc	0.00	157.80
	7802	01/13/2014	V01777	Lakeshore Learning	0.00	174.80
	7803	01/13/2014	V60721	Learning Incentive Inc, The	0.00	5,100.00
	7804	01/13/2014	V00039	Leonards Auto Parts Co.	0.00	44.78
	7805	01/13/2014	V02338	Longstreth	0.00	39.91
	7806	01/13/2014	V60897	Mac to School	0.00	899.00
	7807	01/13/2014	V02898	MagnaKleen Services	0.00	203.90
	7808	01/13/2014	E00538	Mancuso, Amy	0.00	185.12
	7809	01/13/2014	V53584	Marcy Cook Math	0.00	117.60
	7810	01/13/2014	E00690	Messina, Denise	0.00	166.36
	7811	01/13/2014	V54159	Vernon Printing Co, Inc.	0.00	102.00
	7812	01/13/2014	V60104	Nixon Company Inc., The	0.00	564.00
	7813	01/13/2014	V60568	Pediatric Services of America Inc	0.00	6,603.75
	7814	01/13/2014	V60053	Premier Laboratory, Inc	0.00	315.00
	7815	01/13/2014	V60864	Pullman & Comley, LLC	0.00	7,628.50
	7816	01/13/2014	V60925	ReadyNurse Staffing Serices	0.00	126.50
	7817	01/13/2014	V53890	Renaissance Learning	0.00	1,280.00
	7818	01/13/2014	E00288	Roberts, Steven	0.00	37.29
	7819	01/13/2014	V51385	Rockwell Communications	0.00	135.00
	7820	01/13/2014	V00994	Rolf Engineering Inc	0.00	805.00
	7821	01/13/2014	V60760	Salomone, Dr Kathleen	0.00	1,560.00
	7822	01/13/2014	V60538	School Outfitters	0.00	517.66
	7823	01/13/2014	V60913	School Outlet.com	0.00	707.43
	7824	01/13/2014	V01292	School Specialty, Inc.	0.00	696.00
	7825	01/13/2014	V60031	SNE Building Systems	0.00	5,035.00

Somers Board of Education General Budget Treasury Warrant

Report # 26680

Batch #	Check #	Check Date	Vendor Code	Vendor Name	Electronic Amount	Check Amount
	7826	01/13/2014	V02404	Somers Ace Hardware	0.00	418.29
	7827	01/13/2014	V00486	Somers High School	0.00	1,274.00
	7828	01/13/2014	V00886	Somers Lunch Program	0.00	4.65
	7829	01/13/2014	V60809	Somers Mechanical Services, LLC	0.00	537.00
	7830	01/13/2014	V60616	Somers Public Schools	0.00	2,308.32
	7831	01/13/2014	V00548	Somers Sanitation Service, Inc.	0.00	1,189.70
	7832	01/13/2014	V01591	Town of Somers	0.00	10,285.83
	7833	01/13/2014	V60394	SWAN Associates Inc	0.00	858.56
	7834	01/13/2014	M02015	T. J. Conway Company	0.00	1,157.44
	7835	01/13/2014	V60374	Tecta America New England LLC	0.00	2,031.35
	7836	01/13/2014	V60248	Total Protection Security Systems LLC	0.00	11,175.70
	7837	01/13/2014	V53945	Transcanda Power Marketing LTD	0.00	14,769.19
	7838	01/13/2014	M53099	Tull Brothers, Inc.	0.00	1,266.90
	7839	01/13/2014	V21164	Unum Life Insurance Company of America	0.00	3,788.68
	7840	01/13/2014	V00766	Valley Communications Systems, Inc.	0.00	117.00
	7841	01/13/2014	V54059	Verizon Wireless	0.00	977.31
	7842	01/13/2014	V00616	Vernon Public Schools	0.00	3,600.00
	7843	01/13/2014	V60906	Water Waste Equipment, Inc.	0.00	4,260.50
	7844	01/13/2014	V21268	Webber, M. Jackson	0.00	1,961.50
	7845	01/13/2014	V02738	William V. MacGill & Co.	0.00	131.88
	7846	01/13/2014	E00571	Wilson, Robert	0.00	25.98
	7847	01/13/2014	V60875	Zones Inc	0.00	1,110.57
Totals:					0.00	\$443,583.80

116 Checks Listed.

Somers Board of Education General Journal Register

Report # 26679
Batch: 9484
Transaction: N/A
Show Summary Only: Yes

Batch #	Control Total	Status	Created By	Created On	Last Updated By	Last Updated On
9484	\$443,583.80	Posted	lbergamini	01/06/2014	lbergamini	01/09/2014

General Ledger Distribution Summary						
Period, Fiscal Year	Account Number	Account Description	DTF Base	Over Budget	Debits	Credits
January, 2014						
Generated Distributions						
	10-000-0-0-00-000-710-00-0-00000	ENCUMBRANCE CONTROL			435,700.55	0.00
	10-000-0-0-00-000-720-00-0-00000	RESERVE FOR ENCUMBRANCE			0.00	435,700.55
		Total Generated Distributions			\$435,700.55	\$435,700.55
User-Entered Distributions						
	10-000-0-0-00-000-241-00-0-00000	ACCOUNTS PAYABLE			0.00	443,583.80
	10-100-2-2-18-242-611-01-5-00187	K-5 - MATH SUPPLIES			1,306.80	0.00
	10-100-2-3-12-242-611-01-5-00182	MA - TECHNOLOGY ED SUPPLIES			280.13	0.00
	10-100-2-3-14-241-611-01-5-00157	MA - GENERAL SUPPLIES			183.03	0.00
	10-100-2-3-22-242-611-01-5-00194	MA - PHYSICAL ED SUPPLIES			271.64	0.00
	10-100-2-3-28-242-611-01-5-00204	MA - SCIENCE SUPPLIES			816.83	0.00
	10-100-2-3-30-243-611-01-5-01074	MA - SOCIAL STUDIES WORKBOOKS			34.15	0.00
	10-100-2-4-12-242-611-01-5-00183	HS - TECHNOLOGY ED SUPPLIES			648.05	0.00
	10-100-2-4-14-241-611-01-5-00159	HS - GENERAL SUPPLIES			264.59	0.00
	10-100-2-4-16-220-641-01-5-00120	HS - ENGLISH TEXTBOOKS			690.30	0.00
	10-100-2-4-22-242-611-01-5-00195	HS - PHYSICAL ED SUPPLIES			138.27	0.00
	10-100-2-4-26-242-611-01-5-01070	HS - ENGLISH SUPPLIES			32.05	0.00
	10-100-2-4-28-242-611-01-5-00206	HS - SCIENCE SUPPLIES			59.46	0.00
	10-100-2-4-46-242-611-01-5-00229	HS - SCHOOL TO CAREER SUPPLIES			114.00	0.00
	10-100-2-4-99-242-611-01-5-00180	HS - SAT PREP		Yes	2,554.00	0.00
	10-100-2-5-14-241-611-01-5-00873	SW - GENERAL COMPUTER SUPPLIES			2,678.04	0.00
	10-100-2-5-81-242-611-01-5-00860	SW - INTERVENTION SUPPLIES			140.00	0.00
	10-100-8-2-66-910-730-01-5-00603	K-5 CAPITAL OUTLAY			730.19	0.00
	10-100-8-4-66-910-730-01-5-00607	HS CAPITAL OUTLAY			707.43	0.00
	10-100-8-4-66-910-730-01-5-00965	HS - TECH ED CAPITAL OUTLAY			4,112.00	0.00
	10-120-9-3-98-242-611-01-5-00213	MA - ALTERNATIVE ED PROG			42.00	0.00
	10-120-9-9-98-242-611-01-5-00214	MA - RESOURCE ROOM SUPPLIES			90.00	0.00
	10-120-9-9-98-242-611-01-5-00215	MA - RESOURCE ROOM SUPPLIES			97.00	0.00
	10-120-9-9-98-242-611-01-5-00226	MA - ALP SUPPLIES			75.00	0.00
	10-120-9-9-98-251-580-05-5-00273	SP ED - DIRECTOR'S TRAVEL			166.36	0.00
	10-120-9-9-98-955-330-02-5-01117	SP ED-INDEPENDENT EVALUATIONS		Yes	800.00	0.00

Somers Board of Education General Journal Register

Batch #	Control Total	Status	Created By	Created On	Last Updated By	Last Updated On
9484	\$443,583.80	Posted	Ibergamini	01/06/2014	Ibergamini	01/09/2014
					846.00	0.00
					368.29	0.00
					1,855.34	0.00
					100.00	0.00
				Yes	1,234.00	0.00
					322.88	0.00
				Yes	50.00	0.00
					8,290.42	0.00
					1,135.77	0.00
				Yes	708.56	0.00
					2,031.35	0.00
					1,189.70	0.00
				Yes	591.55	0.00
					16.78	0.00
				Yes	158.00	0.00
					283.00	0.00
					906.44	0.00
				Yes	38.68	0.00
				Yes	11,175.70	0.00
					22,224.11	0.00
					4,125.26	0.00
					18,744.17	0.00
					11,746.48	0.00
					188.37	0.00
					1,555.19	0.00
					899.18	0.00
					950.84	0.00
				Yes	5,421.80	0.00
					2,426.19	0.00
					20.60	0.00
					19,768.00	0.00
					23,746.36	0.00
					9,932.62	0.00
					3,659.76	0.00
					15,850.00	0.00
					471.50	0.00
					353.21	0.00
					66.60	0.00

Somers Board of Education General Journal Register

Report # 26679

Batch #	Control Total	Status	Created By	Created On	Last Updated By	Last Updated On
9484	\$443,583.80	Posted	lbergamini	01/06/2014	lbergamini	01/09/2014
		10-280-6-5-82-820-200-13-5-00512	LIFE AND AD&D INSURANCE		2,374.43	0.00
		10-280-6-5-82-820-200-13-5-00513	L.T.D.		3,788.68	0.00
		10-280-6-5-82-820-200-13-5-00516	WORKER'S COMPENSATION	Yes	632.00	0.00
		10-280-6-5-82-820-200-13-5-01185	SW - HEALTH MAINTENANCE ORG.		50,189.69	0.00
		10-280-6-5-82-820-200-13-5-01186	SW - PREFERRED PROVIDER ORG.		137,203.49	0.00
		10-280-6-5-82-820-200-13-5-01228	SW - HEALTH SAVINGS ACCOUNT	Yes	2,344.14	0.00
		10-320-7-3-42-880-690-06-5-00594	MA - ATHLETIC SUPPLIES		39.91	0.00
		10-320-7-4-42-880-690-06-5-00595	HS - ATHLETIC SUPPLIES		577.43	0.00
		10-320-7-4-42-880-690-06-5-00601	HS - ATHLETIC AWARDS		630.50	0.00
		10-611-6-5-88-950-560-14-5-00621	VO-AG - TUITION		3,600.00	0.00
		10-611-9-9-88-955-560-14-5-00813	SP ED - CREC HEARING PROGRAM	Yes	628.00	0.00
		10-613-9-9-88-955-561-14-5-00673	SP ED - TUITION		14,971.90	0.00
			Total User-Entered Distributions		<u>\$443,583.80</u>	<u>\$443,583.80</u>
			Total for January, 2014		<u>\$879,284.35</u>	<u>\$879,284.35</u>
			Grand Total for Batch # 9484		<u><u>\$879,284.35</u></u>	<u><u>\$879,284.35</u></u>

486 Transactions Listed.

2014-2015 SOMERS PUBLIC SCHOOLS

JULY '14						
S	M	T	W	Th	F	S
		1	2	3	4	5
6	7	8	9	10	11	12
13	14	15	16	17	18	19
20	21	22	23	24	25	26
27	28	29	30	31		

4 Independence Day

JANUARY '15 (19)						
S	M	T	W	Th	F	S
				1	2	3
4	5	6	7	8	9	10
11	12	13	14	15	16	17
18	19	20	21	22	23	24
25	26	27	28	29	30	31

1-2 Holiday Recess
19 M.L. King Jr. Day

AUGUST '14 (2)						
S	M	T	W	Th	F	S
					1	2
3	4	5	6	7	8	9
10	11	12	13	14	15	16
17	18	19	20	21	22	23
24	25	26	27	28	29	30
31						

25 Staff Convocation Day
26 Teacher Work Day
27 Teacher Work Day
28 **SCHOOLS OPEN**

FEBRUARY '15 (18)						
S	M	T	W	Th	F	S
1	2	3	4	5	6	7
8	9	10	11	12	13	14
15	16	17	18	19	20	21
22	23	24	25	26	27	28

16 President's Day
17 **Teacher Work Day**

SEPTEMBER '14 (21)						
S	M	T	W	Th	F	S
	1	2	3	4	5	6
7	8	9	10	11	12	13
14	15	16	17	18	19	20
21	22	23	24	25	26	27
28	29	30				

1 Labor Day

MARCH '15 (22)						
S	M	T	W	Th	F	S
1	2	3	4	5	6	7
8	9	10	11	12	13	14
15	16	17	18	19	20	21
22	23	24	25	26	27	28
29	30	31				

18 K-5 Early Release
19 K-5 Early Release
20 K-5 Early Release

OCTOBER '14 (21)						
S	M	T	W	Th	F	S
			1	2	3	4
5	6	7	8	9	10	11
12	13	14	15	16	17	18
19	20	21	22	23	24	25
26	27	28	29	30	31	

2 9-12 Early Release
13 Columbus Day
24 Teacher Work Day

APRIL '15 (16)						
S	M	T	W	Th	F	S
			1	2	3	4
5	6	7	8	9	10	11
12	13	14	15	16	17	18
19	20	21	22	23	24	25
26	27	28	29	30		

3 Good Friday
13-17 April Recess

NOVEMBER '14 (16)						
S	M	T	W	Th	F	S
						1
2	3	4	5	6	7	8
9	10	11	12	13	14	15
16	17	18	19	20	21	22
23	24	25	26	27	28	29
30						

5 6-8 Early Release
6 6-8 Early Release
10 Teacher Work Day
11 Veteran's Day
12 K-5 Early Release
13 K-5 Early Release
14 K-5 Early Release
26 Early Release
27-28 Thanksgiving Recess

MAY '15 (20)						
S	M	T	W	Th	F	S
					1	2
3	4	5	6	7	8	9
10	11	12	13	14	15	16
17	18	19	20	21	22	23
24	25	26	27	28	29	30
31						

25 Memorial Day

DECEMBER '14 (17)						
S	M	T	W	Th	F	S
	1	2	3	4	5	6
7	8	9	10	11	12	13
14	15	16	17	18	19	20
21	22	23	24	25	26	27
28	29	30	31			

24-31 Holiday Recess

JUNE '15 (8)						
S	M	T	W	Th	F	S
	1	2	3	4	5	6
7	8	9	10	11	12	13
14	15	16	17	18	19	20
21	22	23	24	25	26	27
28	29	30				

10 **SCHOOLS CLOSING—**
Early Release
11 Teacher Work Day

Total School Days 180

**SOMERS BOARD OF EDUCATION
Summary by Budget Category**

Account Description	2013-14 Budget	2014-15 Proposed	\$ Change	% Change
ADMINISTRATIVE SALARIES	\$1,237,728	\$1,255,497	\$17,769	1.4%
FORMS AND PRINTING	\$11,500	\$11,500	\$0	0.0%
POSTAGE	\$11,195	\$11,195	\$0	0.0%
BOARD OF ED. EXPENSES	\$93,600	\$124,600	\$31,000	33.1%
INSTITUTIONAL DUES	\$21,285	\$21,285	\$0	0.0%
INSTRUCTIONAL SALARIES	\$9,243,133	\$9,490,146	\$247,013	2.7%
OTHER INST. SALARIES	\$422,911	\$434,824	\$11,913	2.8%
CLERICAL/AIDES SALARIES	\$1,310,143	\$1,321,512	\$11,369	0.9%
TEXTBOOKS	\$86,400	\$86,400	\$0	0.0%
LIBRARY BOOKS/SUPPLIES	\$13,750	\$13,750	\$0	0.0%
TECHNOLOGY AV MATERIALS	\$10,400	\$10,400	\$0	0.0%
SYSTEMWIDE GEN. SUPPLIES	\$44,800	\$44,800	\$0	0.0%
DEPARTMENTAL SUPPLIES	\$112,910	\$113,910	\$1,000	0.9%
WORKBOOKS AND TEST	\$34,940	\$34,940	\$0	0.0%
TRAVEL/CONF/IN-SERVICE	\$31,350	\$31,350	\$0	0.0%
OFFICE SUPPLIES	\$9,225	\$9,225	\$0	0.0%
MEDICAL ADVISOR SALARY	\$500	\$500	\$0	0.0%
NURSE'S SALARIES	\$137,249	\$157,273	\$20,024	14.6%
HEALTH SUPPLIES	\$7,000	\$7,000	\$0	0.0%
REGULAR TRANSPORTATION	\$650,000	\$665,400	\$15,400	2.4%
SPEC. ED. TRANSPORTATION	\$274,480	\$281,280	\$6,800	2.5%
ATHLETIC/FIELD TRIPS	\$25,480	\$26,680	\$1,200	4.7%
MAINT/CUSTODIAN SALARIES	\$669,765	\$669,765	\$0	0.0%
FUEL SUPPLY	\$219,200	\$219,200	\$0	0.0%
ELECTRICITY	\$347,977	\$347,977	\$0	0.0%
TELEPHONE	\$22,400	\$22,400	\$0	0.0%
PROPANE GAS	\$11,000	\$11,000	\$0	0.0%
CUSTODIAL SUPPLIES	\$45,000	\$45,000	\$0	0.0%
GENERAL/DEPT MAINTENANCE	\$341,571	\$341,571	\$0	0.0%
EQUIPMENT REPLACEMENT	\$2,800	\$2,800	\$0	0.0%
INSURANCE/SOC. SECURITY	\$3,572,631	\$3,564,800	-\$7,831	-0.2%
EQUIPMENT RENTAL	\$52,440	\$52,440	\$0	0.0%
COACHES	\$150,903	\$151,511	\$608	0.4%
ACTIVITY ADVISORS	\$29,828	\$34,847	\$5,019	16.8%
ATHLETIC/ACADEMIC ACT.	\$72,716	\$74,716	\$2,000	2.8%
CAPITAL OUTLAY/EQUIP	\$196,570	\$193,570	-\$3,000	-1.5%
TUITION-NON SPECIAL ED	\$119,000	\$119,000	\$0	0.0%
TUITION VO-AG	\$8,000	\$8,000	\$0	0.0%
TUITION-SPECIAL ED.	\$693,200	\$694,700	\$1,500	0.2%
ADULT EDUCATION	\$12,900	\$12,900	\$0	0.0%
OTHER	\$0	\$0	\$0	#DIV/0!
TOTAL	\$20,357,880	\$20,719,664	\$361,784	1.78%

**SOMERS BOARD OF EDUCATION
Summary by Budget Category**

SALARIES

Account Description	2013-14 Budget	2014-15 Proposed	\$ Change	% Change
ADMINISTRATIVE SALARIES	\$1,237,728	\$1,255,497	\$17,769	1.4%
INSTRUCTIONAL SALARIES	\$9,243,133	\$9,490,146	\$247,013	2.7%
OTHER INST. SALARIES	\$422,911	\$434,824	\$11,913	2.8%
CLERICAL/AIDES SALARIES	\$1,310,143	\$1,321,512	\$11,369	0.9%
MEDICAL ADVISOR SALARY	\$500	\$500	\$0	0.0%
NURSE'S SALARIES	\$137,249	\$157,273	\$20,024	14.6%
MAINT/CUSTODIAN SALARIES	\$669,765	\$669,765	\$0	0.0%
COACHES	\$150,903	\$151,511	\$608	0.4%
ACTIVITY ADVISORS	\$29,828	\$34,847	\$5,019	16.8%
	\$13,202,160	\$13,515,875	\$313,715	2.38%

PROGRAM SUPPORT

Account Description	2013-14 Budget	2014-15 Proposed	\$ Change	% Change
TEXTBOOKS	\$86,400	\$86,400	\$0	0.0%
LIBRARY BOOKS/SUPPLIES	\$13,750	\$13,750	\$0	0.0%
TECHNOLOGY AV MATERIALS	\$10,400	\$10,400	\$0	0.0%
SYSTEMWIDE GEN. SUPPLIES	\$44,800	\$44,800	\$0	0.0%
DEPARTMENTAL SUPPLIES	\$112,910	\$113,910	\$1,000	0.9%
WORKBOOKS AND TEST	\$34,940	\$34,940	\$0	0.0%
TRAVEL/CONF/IN-SERVICE	\$31,350	\$31,350	\$0	0.0%
ATHLETIC/ACADEMIC ACT.	\$72,716	\$74,716	\$2,000	2.8%
	\$407,266	\$410,266	\$3,000	0.74%

GENERAL SUPPLIES AND MAINTENANCE

Account Description	2013-14 Budget	2014-15 Proposed	\$ Change	% Change
FORMS AND PRINTING	\$11,500	\$11,500	\$0	0.0%
POSTAGE	\$11,195	\$11,195	\$0	0.0%
OFFICE SUPPLIES	\$9,225	\$9,225	\$0	0.0%
HEALTH SUPPLIES	\$7,000	\$7,000	\$0	0.0%
CUSTODIAL SUPPLIES	\$45,000	\$45,000	\$0	0.0%
GENERAL/DEPT MAINTENANCE	\$341,571	\$341,571	\$0	0.0%
EQUIPMENT REPLACEMENT	\$2,800	\$2,800	\$0	0.0%
EQUIPMENT RENTAL	\$52,440	\$52,440	\$0	0.0%
CAPITAL OUTLAY/EQUIP	\$196,570	\$193,570	-\$3,000	-1.5%
OTHER	\$0	\$0	\$0	#DIV/0!
	\$677,301	\$674,301	-\$3,000	-0.44%

**SOMERS BOARD OF EDUCATION
Summary by Budget Category**

UTILITIES AND TRANSPORTATION				
Account Description	2013-14 Budget	2014-15 Proposed	\$ Change	% Change
REGULAR TRANSPORTATION	\$650,000	\$665,400	\$15,400	2.4%
SPEC. ED. TRANSPORTATION	\$274,480	\$281,280	\$6,800	2.5%
ATHLETIC/FIELD TRIPS	\$25,480	\$26,680	\$1,200	4.7%
FUEL SUPPLY	\$219,200	\$219,200	\$0	0.0%
ELECTRICITY	\$347,977	\$347,977	\$0	0.0%
TELEPHONE	\$22,400	\$22,400	\$0	0.0%
PROPANE GAS	\$11,000	\$11,000	\$0	0.0%
	\$1,550,537	\$1,573,937	\$23,400	1.51%

SPECIAL EDUCATION AND OTHER TUITION				
Account Description	2013-14 Budget	2014-15 Proposed	\$ Change	% Change
TUITION-NON SPECIAL ED	\$119,000	\$119,000	\$0	0.0%
TUITION VO-AG	\$8,000	\$8,000	\$0	0.0%
TUITION-SPECIAL ED.	\$693,200	\$694,700	\$1,500	0.2%
ADULT EDUCATION	\$12,900	\$12,900	\$0	0.0%
	\$833,100	\$834,600	\$1,500	0.18%

INSURANCE				
Account Description	2013-14 Budget	2014-15 Proposed	\$ Change	% Change
BOARD OF ED. EXPENSES	\$93,600	\$124,600	\$31,000	33.1%
INSTITUTIONAL DUES	\$21,285	\$21,285	\$0	0.0%
INSURANCE/SOC. SECURITY	\$3,572,631	\$3,564,800	-\$7,831	-0.2%
	\$3,687,516	\$3,710,685	\$23,169	0.63%

TOTAL	\$20,357,880	\$20,719,664	\$361,784	1.78%
--------------	---------------------	---------------------	------------------	--------------

**SOMERS BOARD OF EDUCATION
2014-2015 Budget Planning**

Ref #	Description	2013-14	2014-15	Chg 13-14 to 14-15	
		Budget	Proposed	\$	%
1	SES - Principal	111,000	112,943	1,943	
10	SES - Co-Principal	0	0	0	
1177	SES - Assist. Principal	85,000	86,488	1,488	
3	MA - Assist. Principal	105,127	106,967	1,840	
4	MA - Principal	108,974	110,881	1,907	
6	HS - Assist. Principal	90,000	91,575	1,575	
5	HS - Principal	123,410	125,569	2,159	
8	Superintendent	170,000	170,000	0	
9	Director of Business Services	104,545	104,545	0	
11	Director of Technology	100,000	102,750	2,750	
772	Director of Curriculum	108,502	110,401	1,899	
7	Director of Pupil Services	126,170	128,378	2,208	
854	Merit	5,000	5,000	0	
	Administrative Salaries	1,237,728	1,255,497	17,769	1.44%
15	SES - Forms & Printing	2,500	2,500	0	
17	MA - Forms & Printing	1,700	1,700	0	
18	HS - Forms & Printing	4,000	4,000	0	
19	CO - Forms & Printing	2,500	2,500	0	
1063	SW - Forms & Printing	400	400	0	
20	SP ED - Forms & Printing	400	400	0	
	Forms & Printing	11,500	11,500	0	0.00%
35	SES - Postage	445	445	0	
37	MA - Postage	700	700	0	
646	MA - Guidance Postage	100	100	0	
647	HS - Guidance Postage	1,000	1,000	0	
38	HS - Postage	1,500	1,500	0	
39	CO - Postage	7,300	7,300	0	
40	Maintenance - Postage	0	0	0	
41	Sp Ed - Postage	150	150	0	
	Postage	11,195	11,195	0	0.00%
48	BOE - Publications Postage	750	750	0	
47	BOE - Supplies	700	700	0	
46	BOE - Travel	800	800	0	
49	BOE - Printing	2,500	2,500	0	
50	BOE - Publications	300	300	0	
51	BOE - Audit	3,000	3,000	0	
45	BOE - Other Prof. Services	75,450	106,450	31,000	
31	CO - Petty Cash	1,200	1,200	0	
25	CO - Advertising	6,500	6,500	0	
875	SW - Prof. Development Supp.	1,200	1,200	0	
648	BOE - Community Relations	1,200	1,200	0	
	BOE Expenses	93,600	124,600	31,000	33.12%
53	SES - Institutional Dues	400	400	0	
55	MA - Institutional Dues	1,040	1,040	0	
56	HS - Institutional Dues	7,500	7,500	0	
58	BOE - Institutional Dues	7,040	7,040	0	
57	CO - Institutional Dues	4,655	4,655	0	

**SOMERS BOARD OF EDUCATION
2014-2015 Budget Planning**

Ref #	Description	2013-14	2014-15	Chg 13-14 to 14-15	
		Budget	Proposed	\$	%
59	Sp Ed - Institutional Dues	650	650	0	
1064	NEASC Accreditation			0	
1576	Gateways Dues	0	0	0	
	Institutional Dues	21,285	21,285	0	0.00%
60	SES - Instructional Staff	2,689,762	2,757,066	67,304	
1229	SES - Librarian	72,741	75,468	2,727	
73	MA - Librarian Salary	79,235	80,503	1,268	
74	MA - Guidance Salaries	65,443	68,005	2,562	
63	MA - Instructional Staff	1,685,705	1,722,197	36,492	
78	HS - Summer Guidance	18,589	19,015	426	
77	HS - Guidance Salaries	231,747	237,058	5,311	
79	HS - Librarian	74,639	80,503	5,864	
64	HS - Instructional Staff	2,535,888	2,596,567	60,679	
822	SW - Intervention Program	171,648	177,181	5,533	
13	Sp Ed - Internal Programs			0	
84	SW - Psychologist	85,543	86,912	1,369	
67	Sp Ed - Elementary Salaries	678,130	707,265	29,135	
85	SW - Social Worker	103,922	108,773	4,851	
69	Speech - Salaries	206,128	212,103	5,975	
68	Sp Ed - Secondary Salaries	407,787	423,037	15,250	
12	HS - School to Career	55,465	56,352	887	
1342	SW - Media Specialist	80,761	82,141	1,380	
1343	SW - Math/Science Specialist			0	
	Retirement Adjustment	0	0	0	
	Instructional Salaries	9,243,133	9,490,146	247,013	2.67%
1139	Sp Ed - Summer Pre-School	2,100	2,100	0	
1145	SES - Team Leaders	11,571	12,726	1,155	
76	MA - Team Leaders	6,612	7,272	660	
81	HS - After School Suspension	600	600	0	
1065	HS - Team Leaders	11,571	12,726	1,155	
65	SW - Change of Status	0	0	0	
1170	SW - Teacher Sub Long Term	30,000	30,000	0	
1171	SW - Teacher Sub Other	21,000	21,000	0	
66	SW - Teacher Sub Sick/Personal	80,000	80,000	0	
1019	SW - Subs for Prof Development	16,000	16,000	0	
659	SW - Prof. Development/CEU	5,600	5,600	0	
70	SW - Homebound	13,000	13,000	0	
650	Mentors	3,500	3,500	0	
830	SW - Retirement	113,000	113,000	0	
889	SpEd Summer Programs	7,300	14,300	7,000	
888	SES - Tutors	34,600	35,300	700	
61	MA - Tutors	25,515	26,000	485	
71	HS - Tutors	38,142	38,900	758	
1672	HS - Virtual High School	2,800	2,800	0	
	Other Instruct. Salaries	422,911	434,824	11,913	2.82%
89	SES - Secretaries	80,169	81,548	1,379	
87	SES - Library Aides	24,411	24,825	414	
1153	SES - Aides	0	0	0	
1154	MA - Media Aides	13,125	13,348	223	

**SOMERS BOARD OF EDUCATION
2014-2015 Budget Planning**

Ref #	Description	2013-14	2014-15	Chg 13-14 to 14-15	
		Budget	Proposed	\$	%
90	MA - Secretaries	73,247	74,500	1,253	
91	MA - Aides	0	0	0	
94	HS - Library Aides	22,845	23,251	406	
93	HS - Guidance Secretaries	43,708	44,452	744	
92	HS - Secretaries	104,656	106,451	1,795	
760	BOE - Recording Secretary	1,890	1,890	0	
102	SW - Substitute Aides	23,282	23,282	0	
96	CO - Clerical	209,082	202,368	-6,714	
97	SW - Clerical Substitutes	5,000	5,000	0	
1219	SW - Technology Aide	88,076	90,130	2,054	
1061	SES - Preschool Aides	24,511	24,925	414	
1230	SpEd - Summer Preschool Aides	2,900	2,900	0	
101	SpEd - High School Aide	136,128	140,412	4,284	
100	SpEd - Mabelle Avery Aides	137,859	139,596	1,737	
99	SpEd - SES - Aides	247,519	251,212	3,693	
98	SpEd - Secretary Salaries	71,735	71,422	-313	
86	HS - School-to-Career Aide	0	0	0	
890	SW - Additional Aides	0	0	0	
	SESA Furlough	0	0	0	
	Clerical & Aides	1,310,143	1,321,512	11,369	0.87%
105	SES - Language Arts Textbook			0	
104	SES - Science Textbooks			0	
1066	SES - Replacement Text			0	
973	SES - Math Textbooks	25,000	25,000	0	
1640	SES - Social Studies Textbooks			0	
1140	MA - Replacement Text	1,200	1,200	0	
651	MA - World Language Textbooks			0	
859	MA - Social Studies Textbooks			0	
895	MA - Language Arts Textbooks			0	
109	MA - Math Textbooks	25,000	25,000	0	
1067	MA - Science			0	
1331	MA - Music			0	
125	HS - Social Studies Textbooks			0	
130	HS - World Language Textbooks			0	
120	HS - English Textbooks	7,000	7,000	0	
1068	HS - Replacement Text	3,200	3,200	0	
127	HS - Math Textbook	25,000	25,000	0	
129	HS - Science Textbooks			0	
131	HS - Technology Ed			0	
850	HS - Business Ed			0	
1642	HS - Restaurant Mgmt			0	
1673	SW - Guidance			0	
1641	SW - Art Textbooks			0	
966	SW - Health			0	
1579	SW - Music			0	
	Textbooks	86,400	86,400	0	0.00%
136	SES - Library Books	4,000	4,000	0	
151	SES - Other Library Supplies	600	600	0	
140	SES - Newspaper/Magazines	200	200	0	
280	SES - Professional Library	200	200	0	
282	MA - Professional Library	100	100	0	

**SOMERS BOARD OF EDUCATION
2014-2015 Budget Planning**

Ref #	Description	2013-14	2014-15	Chg 13-14 to 14-15	
		Budget	Proposed	\$	%
134	MA - Rebinding	150	150	0	
138	MA - Library Books	1,000	1,000	0	
153	MA - Other Library Supplies	300	300	0	
142	MA - Newspaper/Magazines	400	400	0	
154	HS - Other Library Supplies	300	300	0	
143	HS - Newspapers/Magazines	700	700	0	
135	HS - Rebinding	150	150	0	
139	HS - Library Books	5,000	5,000	0	
283	HS - Professional Library	125	125	0	
284	CO - Professional Library	300	300	0	
810	CO - Newspapers/Magazines	125	125	0	
1069	SpEd - Professional Library	100	100	0	
286	SW Media - Professional Library	0	0	0	
	Library Books	13,750	13,750	0	0.00%
144	SES - A.V. Materials	500	500	0	
1151	MA - A. V. Materials	200	200	0	
147	HS - A. V. Materials	700	700	0	
150	SW - Computer Software	8,200	8,200	0	
149	SW - A. V. Materials	800	800	0	
	Technology	10,400	10,400	0	0.00%
155	SES - General Supplies	21,800	21,800	0	
157	MA - General Supplies	5,100	5,100	0	
159	HS - General Supplies	8,500	8,500	0	
873	SW - General Computer Supplies	9,000	9,000	0	
160	SpEd - General Supplies	400	400	0	
	General Supplies	44,800	44,800	0	0.00%
771	SES - First Grade Supplies	350	350	0	
799	SES - Second Grade Supplies	385	385	0	
846	SES - Third Grade Supplies	405	405	0	
904	SES - Remedial Reading Supplies	2,000	2,000	0	
722	SES - Language Arts Supplies	11,040	11,040	0	
187	SES - Math Supplies	2,460	2,460	0	
193	SES - Physical Ed Supplies	700	700	0	
202	SES - Science/Health Supplies	4,460	4,460	0	
208	SES - Social Studies Supplies	4,600	4,600	0	
169	SES - Music Supplies	4,400	4,400	0	
161	SES - Art Supplies	4,350	4,350	0	
1149	SES - Intervention - Math	190	190	0	
1183	SES - Fifth Grade Supplies	420	420	0	
1182	SES - Fourth Grade Supplies	380	380	0	
652	SES - Kindergarten Supplies	700	1,000	300	
230	SES - ALP I Supplies	100	100	0	
217	SES - Speech/Hearing Supplies	170	170	0	
1580	SES - World Language	800	800	0	
747	Preschool - Speech/Hearing Supp.	150	150	0	
224	MA - Guidance Instruction Supplies	560	560	0	
1218	MA - Health & Life Skills Supplies	400	400	0	
189	MA - Math Supplies	1,450	1,450	0	
194	MA - Physical Ed Supplies	450	450	0	

**SOMERS BOARD OF EDUCATION
2014-2015 Budget Planning**

Ref #	Description	2013-14	2014-15	Chg 13-14 to 14-15	
		Budget	Proposed	\$	%
164	MA - Art Supplies	2,400	2,400	0	
204	MA - Science Supplies	2,500	2,500	0	
210	MA - Social Studies Supplies	2,170	2,170	0	
182	MA - Technology Ed Supplies	3,600	3,600	0	
172	MA - Music Supplies	2,480	2,480	0	
184	MA - Language Arts Supplies	3,900	3,900	0	
816	MA - World Language Supplies	250	250	0	
226	MA - ALP Supplies	100	100	0	
214	MA - Resource Room Supplies	120	120	0	
215	MA - Resource Room Supplies	130	130	0	
213	MA - Alternative Ed Program	200	200	0	
176	HS - Business Ed Supplies	2,050	2,050	0	
206	HS - Science Supplies	7,260	7,260	0	
186	HS - Reading Supplies	500	500	0	
168	HS - Band Supplies	1,850	1,850	0	
191	HS - Math Supplies	3,200	3,200	0	
183	HS - Technology Ed Supplies	6,400	6,400	0	
181	HS - Quantity Foods Supplies	4,250	4,250	0	
178	HS - Guidance Supplies	1,950	1,950	0	
165	HS - Art Supplies	7,300	7,300	0	
195	HS - Physical Ed Supplies	1,500	1,500	0	
1070	HS - English Supplies	2,650	2,650	0	
180	HS - SAT Prep	2,350	2,350	0	
809	HS - Renaissance	750	750	0	
173	HS - College Connections	0	0	0	
286	HS - Guidance Naviance	2,300	3,000	700	
229	HS - School-to-Career Supplies	700	700	0	
231	HS - ALP I Supplies	220	220	0	
1644	HS - Social Studies Supplies	1,120	1,120	0	
175	HS - World Language	350	350	0	
721	HS - Health Ed Supplies	550	550	0	
222	SW - A. V. Supplies	2,600	2,600	0	
860	SW - Intervention Supplies	210	210	0	
852	SW - Math Supplies	400	400	0	
1150	SW - Science Supplies	400	400	0	
232	SW - Gifted & Talented Supplies	490	490	0	
219	SW - Speech/Hearing Supplies	200	200	0	
225	SW - Social Work Supplies	250	250	0	
1332	SW - Occ Therapy Supplies	180	180	0	
1333	SW - Physical Therapy Supplies	200	200	0	
179	SW - Literacy Supplies	100	100	0	
1071	SW - English Supplies	100	100	0	
1027	SW - School Psychology Supplies	450	450	0	
228	SpEd - K-5 ALP A Supplies	160	160	0	
882	SpEd - E.S.L. Supplies	40	40	0	
1073	SpEd - Preschool Supplies	150	150	0	
216	SpEd - High School Supplies	200	200	0	
212	SpEd - K-5 Supplies	190	190	0	
1334	SpEd - Intervention Programs	180	180	0	
1643	SpEd - SHS Rebuilding Program	390	390	0	
	Departmental Supplies	112,910	113,910	1,000	0.89%
244	SES - Social Studies Workbooks	0	0	0	
240	SES - Language Arts Workbooks	0	0	0	

**SOMERS BOARD OF EDUCATION
2014-2015 Budget Planning**

Ref #	Description	2013-14	2014-15	Chg 13-14 to 14-15	
		Budget	Proposed	\$	%
238	SES - Math Workbooks	20,375	20,375	0	
255	MA - World Language Workbooks	1,620	1,620	0	
246	MA - English Workbooks	500	500	0	
247	MA - Reading Workbooks	0	0	0	
1074	MA - Social Studies Workbooks	660	660	0	
887	HS - Social Studies Workbooks	550	550	0	
972	HS - Health Workbooks	400	400	0	
1581	HS - World Language	1,600	1,600	0	
247	HS - Music Workbooks	250	250	0	
252	SW - Testing	5,000	5,000	0	
1002	SpEd - Testing	3,985	3,985	0	
	Workbooks	34,940	34,940	0	0.00%
259	SES - In-Service/Travel	2,200	2,200	0	
260	SES - Principal In-Service/Travel	1,000	1,000	0	
263	MA - In-Service/Travel	1,000	1,000	0	
264	MA - Principal In-Service/Travel	800	800	0	
269	HS - Principal In-Service/Travel	1,000	1,000	0	
267	HS - In-Service/Travel	2,350	2,350	0	
300	Curriculum Development	16,700	16,700	0	
297	CO - Administration Workshop	500	500	0	
271	CO - In-Service/Travel	3,500	3,500	0	
857	SW - Custodial Training	0	0	0	
272	SpEd - In-Service/Travel	500	500	0	
273	SpEd Director - In-Service/Travel	1,800	1,800	0	
	In-Service/Travel	31,350	31,350	0	0.00%
301	SES - Office Supplies	700	700	0	
303	MA - Office Supplies	700	700	0	
304	HS - Office Supplies	1,250	1,250	0	
305	SW - Media Office Supplies	175	175	0	
44	CO - Computer Supplies	1,500	1,500	0	
42	CO - Office Supplies	4,500	4,500	0	
306	Maintenance - Office Supplies	50	50	0	
307	SpEd - Office Supplies	350	350	0	
	Office Supplies	9,225	9,225	0	0.00%
313	SW - Medical Advisor	500	500	0	
	Medical Advisor Salary	500	500	0	0.00%
316	SES - Nurse Salaries	52,330	72,354	20,024	
317	MA - Nurse Salary	41,819	41,819	0	
318	HS - Nurse Salary	35,800	35,800	0	
319	SW - Nurse Substitute	3,000	3,000	0	
314	SW - Head Nurse	2,200	2,200	0	
833	SW - Additional Nurse Time	2,100	2,100	0	
	Nurses Salaries	137,249	157,273	20,024	14.59%
1146	SW - Health Supplies	6,000	6,000	0	
1076	SW - Health Equipment	1,000	1,000	0	

**SOMERS BOARD OF EDUCATION
2014-2015 Budget Planning**

Ref #	Description	2013-14	2014-15	Chg 13-14 to 14-15	
		Budget	Proposed	\$	%
	Health Supplies	7,000	7,000	0	0.00%
327	Bus Fuel	114,000	114,000	0	
326	Transportation - Secondary	290,000	298,400	8,400	
325	Transportation - Elementary	243,000	250,000	7,000	
328	Additional Transportation	3,000	3,000	0	
1582	Bus Monitor			0	
	Regular Transportation	650,000	665,400	15,400	2.37%
333	SpEd - Transportation Aide	42,000	43,200	1,200	
332	SpEd - Additional Mileage	38,480	38,480	0	
329	SpEd - Vans	194,000	199,600	5,600	
	Special Ed Transportation	274,480	281,280	6,800	2.48%
336	MA - Athletic Trips	700	700	0	
340	MA - Band Travel	0	0	0	
337	HS - Athletic Trips	42,000	43,200	1,200	
268	HS - Band Travel	1,230	1,230	0	
845	HS - Field Trips	1,550	1,550	0	
338	Pay to Play	-20,000	-20,000	0	
	Athletic/Band/Academic Travel	25,480	26,680	1,200	4.71%
350	Maintenance Personnel	87,285	87,285	0	
349	Maintenance Supervisor	67,650	67,650	0	
348	Custodial Substitutes	20,773	20,773	0	
351	Summer Crew Maintenance	5,500	5,500	0	
352	Maintenance Overtime	7,000	7,000	0	
343	SES - Custodian Salaries	156,131	156,131	0	
344	MA - Custodian Salaries	160,520	160,520	0	
345	Recreation Program	4,500	4,500	0	
346	HS - Custodian Salaries	150,406	150,406	0	
347	Custodial Overtime	10,000	10,000	0	
877	SW - Asbestos Stipend			0	
	06-07 UFCW Contract Retro Pay			0	
	Maint/Custodian Salaries	669,765	669,765	0	0.00%
354	SES - Fuel #2	99,000	99,000	0	
356	HS - Fuel #2	118,000	118,000	0	
357	Maintenance - Fuel #2	2,200	2,200	0	
	Fuel Supply	219,200	219,200	0	0.00%
361	HS - Electricity	120,000	120,000	0	
360	MA - Electricity	140,000	140,000	0	
358	SES - Electricity	85,000	85,000	0	
362	Maintenance - Electricity	2,977	2,977	0	
1335	MA - Projected Electricity Savings			0	
	Electricity	347,977	347,977	0	0.00%

**SOMERS BOARD OF EDUCATION
2014-2015 Budget Planning**

Ref #	Description	2013-14	2014-15	Chg 13-14 to 14-15	
		Budget	Proposed	\$	%
363	SES - Telephone	3,800	3,800	0	
365	MA - Telephone	1,800	1,800	0	
366	HS - Telephone	5,500	5,500	0	
965	HS - Cable Classroom Internet	0	0	0	
367	CO - Telephone	5,500	5,500	0	
1217	SW - Communication Supplies	5,800	5,800	0	
	Telephone	22,400	22,400	0	0.00%
372	HS - Propane Gas	3,000	3,000	0	
371	MA - Propane Gas	3,000	3,000	0	
369	SES - Propane Gas	5,000	5,000	0	
	Propane Gas	11,000	11,000	0	0.00%
377	SW - Custodial Supplies	45,000	45,000	0	
	Custodial Supplies	45,000	45,000	0	0.00%
378	SES - Music Maintenance	100	100	0	
1141	SES - Building Repairs	50,000	35,000	-15,000	
409	MA - Equipment Maintenance	100	100	0	
382	MA - Music Maintenance	300	300	0	
383	MA - Science Maintenance	200	200	0	
384	MA - Art Maintenance	300	300	0	
385	MA - Home Ec Maintenance	100	100	0	
386	MA - Band Maintenance	500	500	0	
387	MA - Technology Ed Maintenance	600	600	0	
389	MA - Office Equip. Maintenance	100	100	0	
840	SW - Trailer Rental	0	0	0	
416	HS - Library Equipment Maintenance	0	0	0	
433	HS - Scheduling Service	1,700	1,700	0	
390	HS - Science Maintenance	1,175	1,175	0	
391	HS - Art Maintenance	200	200	0	
393	HS - Quantity Foods Maintenance	3,775	3,775	0	
394	HS - Athletics Maintenance	300	300	0	
395	HS - Technology Ed Maintenance	3,900	3,900	0	
396	HS - Music Maintenance	800	800	0	
403	HS - Office Equipment	200	200	0	
398	HS - Math Maintenance	200	200	0	
341	SW - Gasoline Maint. Vehicles	7,500	7,500	0	
452	SW - Maintenance Contracts	45,340	45,340	0	
467	SW - General Paint	3,500	3,500	0	
471	SW - Fire Alarms & Bells	2,500	2,500	0	
438	HS - Septic Tank	2,900	2,900	0	
439	HS - Building Maintenance	30,000	40,000	10,000	
440	SW - Equipment Repair	7,700	7,700	0	
445	SW - Tool Supply	2,000	2,000	0	
444	SW - Rubbish Removal	15,000	15,000	0	
442	SW - Grounds Keep	8,000	8,000	0	
447	SW - General Repair	5,000	5,000	0	
448	SW - Fire/Vandalism	1,500	1,500	0	
451	SW - Mower Maintenance	12,000	12,000	0	
654	SW - Asbestos Inspection	600	600	0	
886	SW - Plumbing Supplies	2,500	2,500	0	

**SOMERS BOARD OF EDUCATION
2014-2015 Budget Planning**

Ref #	Description	2013-14	2014-15	Chg 13-14 to 14-15	
		Budget	Proposed	\$	%
885	SW - Electrical Supplies	4,000	4,000	0	
801	SW - Exterminating	2,200	2,200	0	
884	Maint - Building Maintenance	750	750	0	
657	SW - Playground Maintenance	1,500	1,500	0	
430	MA - Building Maintenance	19,000	24,000	5,000	
422	SES - Septic Tank	3,000	3,000	0	
373	SW - Water	25,300	25,300	0	
404	SW - A.V. Maintenance	5,300	5,300	0	
412	SW - Health Maintenance	100	100	0	
435	SW - Thermostat/Controls	2,500	2,500	0	
1077	SW - Computer Maintenance	12,000	12,000	0	
413	SP ED - Equipment Maintenance	100	100	0	
1645	SW - Bibliomation	9,000	9,000	0	
1646	SW - Security	1,500	1,500	0	
431	MA - Septic Tank	2,200	2,200	0	
405	K-5 Office Equipment	0	0	0	
426	MA - Master Clock Maintenance	0	0	0	
449	SW - Locker Repair	0	0	0	
441	SW Glass Repair	0	0	0	
443	SW Roof Repair	6,000	6,000	0	
446	SW - Trepass Control	0	0	0	
453	SW - Software Maintenance	36,531	36,531	0	
1637	Addtl Approp Winter 10-11	0	0	0	
	General Maintenance	341,571	341,571	0	0.00%
472	SW - AV Equipment	1,600	1,600	0	
477	SW - Replacement			0	
489	SW - Maintenance Replacement			0	
616	HS - Tech Ed Replacement	1,200	1,200	0	
	Equipment Replacement	2,800	2,800	0	0.00%
507	HS - Athletic Insurance	7,775	8,200	425	
506	Social Security	363,000	365,000	2,000	
510	Dental	171,200	170,900	-300	
512	Life and AD&D Insurance	26,200	26,200	0	
513	LTD	45,000	45,000	0	
515	Property/Liability Insurance	55,072	57,800	2,728	
521	School Board Legal	8,184	8,600	416	
520	Umbrella Liability Insurance	11,164	11,700	536	
517	Unemployment Insurance	35,000	25,000	-10,000	
516	Worker's Compensation	81,236	83,500	2,264	
855	Pension	225,000	255,000	30,000	
1228	SW - HDHP/HAS	29,700	1,548,300	1,518,600	
1185	SW - Health Maintenance Org.	631,700	94,400	-537,300	
1186	SW - Preferred Provided Org.	1,798,000	779,700	-1,018,300	
1187	SW - Insurance Waivers	45,000	46,100	1,100	
508	Tax Sheltered Annuities/Other Benefits	29,700	29,700	0	
511	SW - Pension Waiver	8,000	8,000	0	
509	SW - Flexible Spending Acct	1,700	1,700	0	
514	SHS Jan 2004 Ins Claim	0	0	0	
	Anthem Demutualization	0	0	0	
	Insurance	3,572,631	3,564,800	-7,831	-0.22%

**SOMERS BOARD OF EDUCATION
2014-2015 Budget Planning**

Ref #	Description	2013-14	2014-15	Chg 13-14 to 14-15	
		Budget	Proposed	\$	%
1011	SES - Copier Maintenance	6,700	6,700	0	
523	SES - Copier Rental	6,500	6,500	0	
524	SES - Copier Supplies	1,000	1,000	0	
527	MA - Copier Rental	6,500	6,500	0	
1012	MA - Copier Supplies	1,000	1,000	0	
1013	MA - Copier Maintenance	4,700	4,700	0	
1188	SpEd - Copier Supplies	0	0	0	
1014	HS - Copier Supplies	1,000	1,000	0	
763	HS - Copier Rental	6,500	6,500	0	
1015	HS - Copier Maintenance	7,000	7,000	0	
905	SW - Copier Supplies/Maintenance	1,040	1,040	0	
861	SW - Desktop Maintenance	0	0	0	
525	CO - Copier Rental	6,500	6,500	0	
526	CO - Postage Meter	1,200	1,200	0	
454	CO - Copier Maintenance	2,500	2,500	0	
1016	CO - Copier Supplies	300	300	0	
	Equipment Rental	52,440	52,440	0	0.00%
1078	MA - Intramural Coaches	7,468	7,471	3	
805	HS - Golf	3,942	3,944	2	
559	HS - Var. Cheerleaders - Winter	1,484	1,500	16	
655	HS - JV Lacrosse -Boys	2,898	2,899	1	
656	HS - Varsity Lacrosse - Girls	4,133	4,135	2	
1178	HS - Varsity Lacrosse - Boys	4,133	4,135	2	
545	HS - JV Soccer - Girls	2,898	2,899	1	
540	HS - JV Soccer - Boys	2,898	2,899	1	
556	HS - Varsity Soccer - Girls	4,133	4,135	2	
552	HS - Varsity Soccer - Boys	4,133	4,135	2	
541	HS - JV Softball	2,898	2,899	1	
553	HS - Varsity Softball	4,133	4,135	2	
537	HS - JV Baseball	2,898	2,899	1	
547	HS - Varsity Baseball	4,133	4,135	2	
542	HS - JV Field Hockey	2,898	2,899	1	
550	HS - Varsity Field Hockey	4,133	4,135	2	
546	HS - Freshmen Basketball - Boys	4,343	4,345	2	
538	HS - JV Basketball - Boys	4,343	4,345	2	
539	HS - JV Basketball - Girls	4,343	4,345	2	
549	HS - Varsity Basketball - Girls	6,182	6,184	2	
548	HS - Varsity Basketball - Boys	6,182	6,184	2	
561	HS - Cross Country-Boys/Girls	4,133	4,135	2	
554	HS - Varsity Track Head	4,133	4,135	2	
560	SW - Athletic Manager	20,700	21,250	550	
737	HS - Varsity Track Asst.Girls	2,898	2,899	1	
844	HS - JV Lacrosse - Girls	2,898	2,899	1	
555	HS - Varsity Wrestling	5,637	5,639	2	
1006	Athletic Trainer	23,000	23,000	0	
551	HS - Asst Cross Country	2,898	2,899	1	
	Coaches	150,903	151,511	608	0.40%
1105	SES - Band Advisor	2,274	2,293	19	
1104	SES - Choral Advisor	1,733	1,748	15	
	SES - Student Council	0	0	0	

**SOMERS BOARD OF EDUCATION
2014-2015 Budget Planning**

Ref #	Description	2013-14	2014-15	Chg 13-14 to 14-15	
		Budget	Proposed	\$	%
1190	MA - Drama Club	2,478	3,675	1,197	
1191	MA - Newspaper Advisor	834	841	7	
1189	MA - Beta Club	752	758	6	
1003	MA - Student Government	1,253	1,264	11	
586	MA - Band Advisor	0	0	0	
1100	MA - Parade Advisor	897	905	8	
564	MA - Yearbook	886	893	7	
1578	MA - Gateways	752	758	6	
562	MA - Chess	752	758	6	
563	MA - Tech	752	758	6	
565	MBA - Cross Country	0	0	0	
584	HS - FBLA	752	758	6	
568	HS - Freshmen	1,442	1,454	12	
569	HS - Sophomores	1,442	1,454	12	
570	HS - Juniors	1,752	2,572	820	
571	HS - Seniors	2,164	3,675	1,511	
572	HS - Drama/Music	2,478	3,675	1,197	
574	HS - Honor Society	1,085	1,094	9	
575	HS - SADD Advisor	752	758	6	
576	HS - Student Council	1,671	1,685	14	
577	HS - Yearbook	3,297	3,325	28	
1173	HS - Math Team	752	758	6	
1174	HS - SSS	1,134	1,144	10	
1175	HS - Big Brothers /Big Sisters	752	758	6	
1172	HS - Jets	587	592	5	
1101	HS - Parade Advisor	1,495	1,508	13	
582	HS - Literary Magazine Advisor	1,305	1,316	11	
944	HS - Student Café Advisor	1,839	1,854	15	
588	HS - Beta	752	758	6	
589	HS - FCCLA	752	758	6	
590	HS - Tech	752	758	6	
1103	HS - Jazz Ensemble	0	0	0	
580	HS - Diversity Coalition	752	758	6	
578	HS - GSA Alliance	752	758	6	
975	HS - Newspaper	2,006	2,023	17	
567	Pay to Park	-14,000	-14,000	0	
	Activity Advisors	29,828	34,847	5,019	16.83%
596	MA - Officials	266	266	0	
594	MA - Athletic Supplies	1,500	1,500	0	
600	MA - Athletic Awards	100	100	0	
849	MA - Academic Awards	250	250	0	
595	HS - Athletic Supplies	12,000	12,000	0	
597	HS - Officials	27,500	27,500	0	
602	HS - Academic Awards	2,500	2,500	0	
601	HS - Athletic Awards	1,900	1,900	0	
1220	HS - Athletic Uniforms	5,000	5,000	0	
1583	HS - Co-op/Unified Sports	16,600	18,600	2,000	
274	HS - Graduation	5,100	5,100	0	
	Athletic/Academic Activities	72,716	74,716	2,000	2.75%
603	SES - Capital Outlay	1,700	1,700	0	
818	MA - Capital Outlay	500	500	0	

**SOMERS BOARD OF EDUCATION
2014-2015 Budget Planning**

Ref #	Description	2013-14	2014-15	Chg 13-14 to 14-15	
		Budget	Proposed	\$	%
1335	MA - Tech Ed Capital Outlay	25,000	24,000	-1,000	
607	HS - Capital Outlay	2,600	2,600	0	
965	HS - Tech Ed Capital Outlay	52,100	50,100	-2,000	
614	CO - Capital Outlay	4,300	4,300	0	
748	SpEd - Capital Outlay Office	370	370	0	
843	SW - Capital Outlay Technology	110,000	110,000	0	
618	SW - Build & Grounds Cap Out	0	0	0	
	Capital Outlay	196,570	193,570	-3,000	-1.53%
1231	Tuition - Non Special Education	119,000	119,000	0	
	Tuition Non Special Ed	119,000	119,000	0	0.00%
621	Tuition - Vo Ag	8,000	8,000	0	
	Tuition Vo Ag	8,000	8,000	0	0.00%
622	SpEd - CREC	140,000	140,000	0	
634	SpEd - CREC Polaris	63,000	63,000	0	
1079	OT/PT	74,200	75,700	1,500	
1117	SpEd - Independent Evaluations	13,000	13,000	0	
1144	SpEd - Out of State Placements	0	0	0	
674	SpEd - Rockville Vo-Ag	0	0	0	
673	SpEd - Tuition	343,000	343,000	0	
670	SpEd - Gengras	0	0	0	
813	SpEd - CREC Hearing Program	15,000	15,000	0	
1180	SpEd Woodstock			0	
1142	SW - Consultant Fees	10,000	10,000	0	
1674	SpEd - Contracted Services	35,000	35,000	0	
	Tuition Special Education	693,200	694,700	1,500	0.22%
638	Enfield Adult Education	12,900	12,900	0	
	Adult Education	12,900	12,900	0	0.00%
1577	SW - Signing Interpreter	0	0	0	
1336	One Time Investment			0	
	Other	0	0	0	#DIV/0!
	TOTAL	20,357,880	20,719,664	361,784	1.78%

SOMERS BOARD OF EDUCATION
2014-2015 Budget Planning

Ref #	Description	10-11		11-12		12-13		10-11		11-12		12-13		2013-14		2014-15		Chg 13-14 to 14-15	
		Actual	Budget	Actual	Budget	Actual	Budget	Budget	Budget	Budget	Budget	Budget	Budget	Budget	Proposed	\$	%		
1	SES - Principal	110,070	0	112,221	0	115,455	0	110,070	0	112,221	0	115,455	0	111,000	112,943	1,943	0	0	
1177	SES - Co-Principal	97,000	97,000	98,955	97,000	101,247	97,000	97,000	98,955	98,955	100,424	100,424	85,000	85,000	86,488	1,488	0	0	
3	MA - Assist. Principal	92,522	92,522	101,793	92,522	103,319	92,522	92,522	101,793	101,793	103,319	103,319	105,127	106,967	1,840	0	0	0	
4	MA - Principal	116,532	116,532	102,282	116,532	107,100	116,532	116,532	102,282	102,282	107,100	107,100	108,974	110,881	1,907	0	0	0	
6	HS - Assist. Principal	99,796	99,796	85,500	99,796	86,700	99,796	99,796	85,500	85,500	86,700	86,700	90,000	91,575	1,575	0	0	0	
5	HS - Principal	117,152	117,152	119,369	117,152	121,287	117,152	117,152	119,369	119,369	121,287	121,287	123,410	125,569	2,159	0	0	0	
8	Superintendent	154,500	154,500	159,000	154,500	165,000	154,500	154,500	159,000	159,000	165,000	165,000	170,000	170,000	0	0	0	0	
9	Director of Business Services	95,211	95,211	97,591	95,211	101,500	95,211	95,211	97,591	97,591	101,500	101,500	104,545	104,545	0	0	0	0	
11	Director of Technology	110,070	110,070	112,221	110,070	115,455	110,070	110,070	112,221	112,221	115,455	115,455	100,000	102,750	2,750	0	0	0	
772	Director of Curriculum	103,000	103,000	105,045	103,000	106,636	103,000	103,000	105,045	105,045	106,636	106,636	108,502	110,401	1,899	0	0	0	
7	Director of Pupil Services	109,974	109,974	105,853	109,974	124,000	109,974	109,974	105,853	105,853	124,000	124,000	126,170	128,378	2,208	0	0	0	
854	Merit	800	800	0	800	0	800	800	0	0	0	0	5,000	5,000	0	0	0	0	
	Administrative Salaries	1,206,627	1,206,627	1,199,830	1,206,627	1,247,699	1,206,627	1,210,828	1,204,871	1,204,871	1,251,876	1,251,876	1,237,728	1,255,497	17,769	1.44%	0	0	0
15	SES - Forms & Printing	1,355	1,355	2,498	1,355	2,500	1,355	2,500	2,500	2,500	2,500	2,500	2,500	2,500	0	0	0	0	
17	MA - Forms & Printing	1,261	1,261	1,684	1,261	1,652	1,261	1,700	1,700	1,700	1,700	1,700	1,700	1,700	0	0	0	0	
18	HS - Forms & Printing	2,843	2,843	3,991	2,843	3,996	2,843	4,000	4,000	4,000	4,000	4,000	4,000	4,000	0	0	0	0	
19	CO - Forms & Printing	1,862	1,862	2,975	1,862	2,513	1,862	2,500	2,500	2,500	2,500	2,500	2,500	2,500	0	0	0	0	
1063	SW - Forms & Printing	247	247	395	247	520	247	400	400	400	400	400	400	400	0	0	0	0	
20	SP ED - Forms & Printing	283	283	400	283	396	283	400	400	400	400	400	400	400	0	0	0	0	
	Forms & Printing	7,851	7,851	11,943	7,851	11,517	11,500	11,500	11,500	11,500	11,500	11,500	11,500	11,500	0	0.00%	0	0	0
35	SES - Postage	435	435	445	435	426	435	445	445	445	445	445	445	445	0	0	0	0	
37	MA - Postage	700	700	700	700	696	700	700	700	700	700	700	700	700	0	0	0	0	
646	MA - Guidance Postage	100	100	100	100	100	100	100	100	100	100	100	100	100	0	0	0	0	
647	HS - Guidance Postage	970	970	1,000	970	938	970	1,000	1,000	1,000	1,000	1,000	1,000	1,000	0	0	0	0	
38	HS - Postage	1,498	1,498	1,494	1,498	1,458	1,498	1,500	1,500	1,500	1,500	1,500	1,500	1,500	0	0	0	0	
39	CO - Postage	7,242	7,242	7,300	7,242	7,250	7,300	7,300	7,300	7,300	7,300	7,300	7,300	7,300	0	0	0	0	
40	Maintenance - Postage	0	0	0	0	0	0	0	0	0	0	0	0	0	0	0	0	0	
41	Sp Ed - Postage	150	150	150	150	125	150	150	150	150	150	150	150	150	0	0	0	0	
	Postage	11,095	11,189	11,189	11,095	10,993	11,195	11,195	11,195	11,195	11,195	11,195	11,195	11,195	0	0.00%	0	0	0
48	BOE - Publications Postage	609	609	589	609	658	609	750	750	750	750	750	750	750	0	0	0	0	
47	BOE - Supplies	309	309	320	309	375	309	700	700	700	700	700	700	700	0	0	0	0	
46	BOE - Travel	20	20	980	20	0	20	800	800	800	800	800	800	800	0	0	0	0	
49	BOE - Printing	3,068	3,068	2,795	3,068	2,525	3,068	2,500	2,500	2,500	2,500	2,500	2,500	2,500	0	0	0	0	
50	BOE - Publications	0	0	0	0	218	0	300	300	300	300	300	300	300	0	0	0	0	
51	BOE - Audit	3,000	3,000	3,000	3,000	3,000	3,000	3,000	3,000	3,000	3,000	3,000	3,000	3,000	0	0	0	0	
45	BOE - Other Prof. Services	102,663	102,663	145,633	102,663	22,742	102,663	24,450	55,450	55,450	75,450	75,450	75,450	106,450	31,000	0	0	0	
31	CO - Petty Cash	1,000	1,000	1,200	1,000	800	1,000	1,200	1,200	1,200	1,200	1,200	1,200	1,200	0	0	0	0	
25	CO - Advertising	3,345	3,345	4,695	3,345	10,140	3,345	6,500	6,500	6,500	6,500	6,500	6,500	6,500	0	0	0	0	
875	SW - Prof. Development Supp.	1,211	1,211	1,200	1,211	1,200	1,211	1,200	1,200	1,200	1,200	1,200	1,200	1,200	0	0	0	0	
648	BOE - Community Relations	798	798	696	798	680	798	1,200	1,200	1,200	1,200	1,200	1,200	1,200	0	0	0	0	
	BOE Expenses	116,023	161,108	42,338	116,023	93,600	42,600	73,600	73,600	93,600	93,600	93,600	93,600	124,600	31,000	33.12%	0	0	0

**SOMERS BOARD OF EDUCATION
2014-2015 Budget Planning**

Ref #	Description	10-11		11-12		12-13		10-11		11-12		12-13		2013-14		2014-15		Chg 13-14 to 14-15	
		Actual	Budget	Actual	Budget	Actual	Budget	Budget	Budget	Budget	Budget	Budget	Budget	Budget	Budget	Budget	Budget	Budget	\$
53	SES - Institutional Dues	350	400	350	400	200	400	400	400	400	400	400	400	400	400	400	400	0	0
55	MA - Institutional Dues	930	1,040	1,099	1,040	1,475	1,040	1,040	1,040	1,040	1,040	1,040	1,040	1,040	1,040	1,040	1,040	0	0
56	HS - Institutional Dues	8,550	7,500	8,438	7,500	8,490	7,500	7,500	7,500	7,500	7,500	7,500	7,500	7,500	7,500	7,500	7,500	0	0
58	BOE - Institutional Dues	7,765	7,040	7,614	7,040	9,366	7,040	7,040	7,040	7,040	7,040	7,040	7,040	7,040	7,040	7,040	7,040	0	0
57	CO - Institutional Dues	3,104	4,655	4,751	4,655	4,859	4,655	4,655	4,655	4,655	4,655	4,655	4,655	4,655	4,655	4,655	4,655	0	0
59	Sp Ed - Institutional Dues	488	650	828	650	431	650	650	650	650	650	650	650	650	650	650	650	0	0
1064	NEASC Accreditation	0	0	0	0	0	0	0	0	0	0	0	0	0	0	0	0	0	0
1576	Gateways Dues	0	0	0	0	0	0	0	0	0	0	0	0	0	0	0	0	0	0
	Institutional Dues	21,187	23,080	23,080	24,321	24,321	21,285	21,285	21,285	21,285	21,285	21,285	21,285	21,285	21,285	21,285	21,285	0	0.00%
60	SES - Instructional Staff	2,550,698	2,494,208	2,494,208	2,508,564	2,508,564	2,624,581	2,577,581	2,577,581	2,577,581	2,577,581	2,549,323	2,689,762	2,757,066	2,689,762	2,757,066	2,757,066	67,304	
1229	SES - Librarian	68,934	68,934	68,934	70,745	70,745	68,934	68,934	68,934	68,934	68,934	70,745	72,741	75,468	72,741	75,468	75,468	2,727	
73	MA - Librarian Salary	77,679	76,929	76,929	78,296	78,296	77,679	77,679	77,679	77,679	77,679	78,296	79,235	80,503	79,235	80,503	80,503	1,268	
74	MA - Guidance Salaries	57,553	59,946	59,946	62,262	62,262	57,092	57,092	57,092	57,092	57,092	62,262	65,443	68,005	65,443	68,005	68,005	2,562	
63	MA - Instructional Staff	1,794,332	1,691,757	1,691,757	1,706,283	1,706,283	1,791,855	1,763,855	1,763,855	1,763,855	1,763,855	1,706,985	1,685,705	1,722,197	1,685,705	1,722,197	1,722,197	36,492	
78	HS - Summer Guidance	15,393	16,993	16,993	14,941	14,941	17,702	17,702	17,702	17,702	17,702	18,177	18,589	19,015	18,589	19,015	19,015	426	
77	HS - Guidance Salaries	221,431	221,431	221,431	226,825	226,825	221,431	221,431	221,431	221,431	221,431	226,603	231,747	237,058	231,747	237,058	237,058	5,311	
79	HS - Librarian	68,469	68,469	68,469	71,113	71,113	68,469	68,469	68,469	68,469	68,469	71,113	74,639	80,503	74,639	80,503	80,503	5,864	
64	HS - Instructional Staff	2,558,715	2,449,251	2,449,251	2,475,527	2,475,527	2,555,562	2,555,562	2,555,562	2,555,562	2,555,562	2,484,350	2,535,888	2,596,567	2,535,888	2,596,567	2,596,567	60,679	
822	SW - Intervention Program	181,976	185,317	185,317	165,519	165,519	141,382	188,382	188,382	188,382	188,382	165,495	171,648	177,181	171,648	177,181	177,181	5,533	
13	Sp Ed - Internal Programs	0	0	0	0	0	0	0	0	0	0	0	0	0	0	0	0	0	0
84	SW - Psychologist	83,053	83,053	83,053	84,529	84,529	83,053	83,053	83,053	83,053	83,053	84,529	85,543	86,912	85,543	86,912	86,912	1,369	
87	Sp Ed - Elementary Salaries	581,638	506,846	506,846	653,788	653,788	581,645	467,957	467,957	467,957	467,957	652,885	678,130	707,265	678,130	707,265	707,265	29,135	
85	SW - Social Worker	104,055	104,055	104,055	106,466	106,466	104,055	104,055	104,055	104,055	104,055	106,466	103,922	108,773	103,922	108,773	108,773	4,851	
69	Speech - Salaries	197,558	197,527	197,527	199,059	199,059	197,455	197,455	197,455	197,455	197,455	203,179	206,128	212,103	206,128	212,103	212,103	5,975	
68	Sp Ed - Secondary Salaries	332,291	336,738	336,738	393,809	393,809	332,291	332,291	332,291	332,291	332,291	393,809	407,787	423,037	407,787	423,037	423,037	15,250	
12	HS - School to Career	53,850	53,850	53,850	54,807	54,807	53,850	53,850	53,850	53,850	53,850	54,807	55,465	56,352	55,465	56,352	56,352	887	
1342	SW - Media Specialist	78,432	78,432	78,432	79,812	79,812	78,432	78,432	78,432	78,432	78,432	79,812	80,761	82,141	80,761	82,141	82,141	1,380	
1343	SW - Math/Science Specialist	0	0	0	0	0	0	0	0	0	0	0	0	0	0	0	0	0	0
	Retirement Adjustment	0	0	0	0	0	0	0	0	0	0	0	0	0	0	0	0	0	0
	Instructional Salaries	9,026,057	8,593,736	8,593,736	8,952,345	8,952,345	9,055,468	8,826,392	8,826,392	8,826,392	9,008,836	9,008,836	9,243,133	9,490,146	9,243,133	9,490,146	9,490,146	247,013	2.67%
1139	Sp Ed - Summer Pre-School	2,309	1,530	1,530	1,303	1,303	2,100	2,100	2,100	2,100	2,100	2,100	2,100	2,100	2,100	2,100	2,100	0	
1145	SES - Team Leaders	11,235	11,235	11,235	11,403	11,403	11,235	11,235	11,235	11,235	11,235	11,403	11,571	12,726	11,571	12,726	12,726	1,155	
76	MA - Team Leaders	6,420	6,420	6,420	6,516	6,516	6,420	6,420	6,420	6,420	6,420	6,516	6,612	7,272	6,612	7,272	7,272	660	
81	HS - After School Suspension	455	585	585	1,378	1,378	600	600	600	600	600	600	600	600	600	600	600	0	
1065	HS - Team Leaders	11,235	11,235	11,235	11,403	11,403	11,235	11,235	11,235	11,235	11,235	11,403	11,571	12,726	11,571	12,726	12,726	1,155	
65	SW - Change of Status	0	0	0	0	0	0	0	0	0	0	0	0	0	0	0	0	0	0
1170	SW - Teacher Sub Long Term	59,501	36,431	36,431	22,955	22,955	30,000	30,000	30,000	30,000	30,000	30,000	30,000	30,000	30,000	30,000	30,000	0	
1171	SW - Teacher Sub Other	19,405	19,050	19,050	18,356	18,356	12,000	12,000	12,000	12,000	12,000	12,000	21,000	21,000	21,000	21,000	21,000	0	
66	SW - Teacher Sub Sick/Personal	71,100	79,463	79,463	71,494	71,494	75,000	75,000	75,000	75,000	75,000	75,000	80,000	80,000	80,000	80,000	80,000	0	
1019	SW - Subs for Prof Development	9,375	10,313	10,313	14,138	14,138	9,643	9,643	9,643	9,643	9,643	9,643	16,000	16,000	16,000	16,000	16,000	0	
659	SW - Prof. Development/CEU	2,880	5,810	5,810	4,290	4,290	5,600	5,600	5,600	5,600	5,600	5,600	5,600	5,600	5,600	5,600	5,600	0	
70	SW - Homebound	4,474	8,988	8,988	8,585	8,585	13,000	13,000	13,000	13,000	13,000	13,000	13,000	13,000	13,000	13,000	13,000	0	
650	Mentors	7,700	4,084	4,084	3,807	3,807	7,700	7,700	7,700	7,700	7,700	7,700	3,500	3,500	3,500	3,500	3,500	0	
830	SW - Retirement	88,648	223,174	223,174	175,587	175,587	96,000	113,000	113,000	113,000	113,000	113,000	113,000	113,000	113,000	113,000	113,000	0	
889	SpEd Summer Programs	7,060	4,344	4,344	7,288	7,288	5,000	5,000	5,000	5,000	5,000	7,300	7,300	14,300	7,300	14,300	14,300	7,000	
888	SES - Tutors	35,450	32,602	32,602	59,485	59,485	28,000	28,000	28,000	28,000	28,000	59,485	34,600	35,300	34,600	35,300	35,300	700	

SOMERS BOARD OF EDUCATION
2014-2015 Budget Planning

Ref #	Description	10-11		11-12		12-13		10-11		11-12		12-13		2013-14		2014-15		Chg 13-14 to 14-15	
		Actual	Actual	Actual	Actual	Budget	Budget	Budget	Budget	Budget	Budget	Budget	Budget	Budget	Proposed	Budget	\$	%	
61	MA - Tutors	25,156	30,264	25,783	28,100	23,942	28,100	23,942	25,515	26,000	25,515	23,942	28,100	26,000	25,515	485			
71	HS - Tutors	36,407	36,549	12,107	37,600	12,909	37,600	12,909	38,142	38,900	38,142	12,909	37,600	38,900	38,142	758			
1672	HS - Virtual High School	2,625	2,750	2,750	2,500	2,500	2,500	2,500	2,800	2,800	2,800	2,500	2,500	2,800	2,800	0			
	Other Instruct. Salaries	401,435	524,827	458,628	381,733	404,101	381,733	404,101	422,911	434,824	422,911	404,101	398,733	434,824	422,911	11,913	2.82%		
89	SES - Secretaries	75,824	75,674	78,700	75,151	78,619	75,151	78,619	80,169	81,548	80,169	78,619	75,151	81,548	80,169	1,379			
87	SES - Library Aides	21,678	21,609	23,545	21,678	23,947	21,678	23,947	24,411	24,825	24,411	23,947	21,678	24,825	24,411	414			
1153	SES - Aides	0	0	0	0	0	0	0	0	0	0	0	0	0	0	0			
1154	MA - Media Aides	12,375	12,375	12,352	12,375	12,875	12,375	12,875	13,125	13,348	13,125	12,875	12,375	13,348	13,125	223			
90	MA - Secretaries	70,103	70,035	71,995	69,948	71,837	69,948	71,837	73,247	74,500	73,247	71,837	69,948	74,500	73,247	1,253			
91	MA - Aides	0	0	0	0	0	0	0	0	0	0	0	0	0	0	0			
94	HS - Library Aides	25,350	25,350	26,050	25,350	26,050	25,350	26,050	22,845	23,251	22,845	26,050	25,350	23,251	22,845	406			
93	HS - Guidance Secretaries	41,845	41,845	42,867	41,845	42,867	41,845	42,867	43,708	44,452	43,708	42,867	41,845	44,452	43,708	744			
92	HS - Secretaries	97,942	99,549	102,309	97,610	102,139	99,186	102,139	104,656	106,451	104,656	102,139	99,186	106,451	104,656	1,795			
760	BOE - Recording Secretary	2,002	1,813	1,710	1,890	1,890	1,890	1,890	1,890	1,890	1,890	1,890	1,890	1,890	1,890	0			
102	SW - Substitute Aides	22,929	27,641	26,010	23,282	23,282	23,282	23,282	23,282	23,282	23,282	23,282	23,282	23,282	23,282	0			
96	CO - Clerical	195,477	197,992	201,506	195,065	202,063	195,065	202,063	209,082	202,368	209,082	202,063	195,065	202,368	209,082	-6,714			
97	SW - Clerical Substitutes	2,271	4,153	6,841	5,000	5,000	5,000	5,000	5,000	5,000	5,000	5,000	5,000	5,000	5,000	0			
1219	SW - Technology Aide	81,755	83,741	85,981	81,755	85,981	83,440	85,981	88,076	90,130	88,076	85,981	83,440	90,130	88,076	2,054			
1061	SES - Preschool Aides	23,282	23,282	23,999	23,000	23,946	23,282	23,946	24,511	24,925	24,511	23,946	23,282	24,925	24,511	414			
1230	SpEd - Summer Preschool Aides	1,331	2,706	1,095	1,200	1,200	1,200	1,200	1,200	1,200	1,200	1,200	1,200	1,200	1,200	0			
101	SpEd - High School Aide	104,805	127,654	131,891	104,943	132,308	127,143	132,308	136,128	140,412	136,128	132,308	127,143	140,412	136,128	4,284			
100	SpEd - Mabelle Avery Aides	126,711	102,118	132,867	122,681	133,515	101,346	133,515	137,859	139,596	137,859	133,515	101,346	139,596	137,859	1,737			
99	SpEd - SES - Aides	205,113	195,970	238,697	200,686	244,359	201,413	244,359	247,519	251,212	247,519	244,359	201,413	251,212	247,519	3,693			
98	SpEd - Secretary Salaries	70,467	69,288	71,560	70,467	71,560	70,467	71,560	71,735	71,422	71,735	71,560	70,467	71,422	71,735	-313			
86	HS - School-to-Career Aide	0	0	0	0	0	0	0	0	0	0	0	0	0	0	0			
890	SW - Additional Aides	0	0	0	0	0	0	0	0	0	0	0	0	0	0	0			
	SESA Furlough	0	0	0	0	0	0	0	0	0	0	0	0	0	0	0			
	Clerical & Aides	1,181,260	1,182,795	1,279,885	1,173,926	1,283,438	1,179,061	1,283,438	1,310,143	1,321,512	1,310,143	1,283,438	1,179,061	1,321,512	1,310,143	11,369	0.87%		
105	SES - Language Arts Textbook	22,643	31,310	27,507	21,000	3,000	17,000	3,000								0			
104	SES - Science Textbooks															0			
1066	SES - Replacement Text															0			
973	SES - Math Textbooks															0			
1640	SES - Social Studies Textbooks															0			
1140	MA - Replacement Text	765	1,187	900	1,300	1,200	1,200	1,200	1,200	1,200	1,200	1,200	1,200	1,200	1,200	0			
651	MA - World Language Textbooks															0			
859	MA - Social Studies Textbooks	26,108		29,584	38,000	28,000	38,000	28,000								0			
895	MA - Language Arts Textbooks															0			
109	MA - Math Textbooks			7,435		14,000		14,000								0			
1067	MA - Science															0			
1331	MA - Music															0			
125	HS - Social Studies Textbooks	781		5,642	12,000	5,000	14,000	5,000								0			
130	HS - World Language Textbooks															0			
120	HS - English Textbooks	1,320		1,447	3,600	13,000	3,200	13,000	7,000	7,000	7,000	13,000	3,200	7,000	7,000	0			
1068	HS - Replacement Text	3,396	3,200	2,648	3,600	3,200	3,600	3,200	3,200	3,200	3,200	3,200	3,200	3,200	3,200	0			
127	HS - Math Textbook			7,535		14,000		14,000								0			
129	HS - Science Textbooks															0			

**SOMERS BOARD OF EDUCATION
2014-2015 Budget Planning**

Ref #	Description	10-11		11-12		12-13		10-11		11-12		12-13		2013-14		2014-15		Chg 13-14 to 14-15	
		Actual	Budget	Actual	Budget	Actual	Budget	Budget	Budget	Budget	Budget	Budget	Budget	Budget	Budget	Proposed	\$	%	
131	HS - Technology Ed	4,482	13,000	13,000	3,500	13,000													
850	HS - Business Ed		10,000	10,000		10,000													
1642	HS - Restaurant Mgmt	1,185	2,000	2,000		2,000													
1673	SW - Guidance		3,639	2,345		5,000													
1641	SW - Art Textbooks	337	7,500			7,500													
966	SW - Health		6,546	346		7,000													
1579	SW - Music		7,500			7,500													
	Textbooks	61,017	85,882	85,389	79,400	86,400	86,400	86,400	86,400	86,400	86,400	86,400	86,400	86,400	86,400	0	0.00%		
136	SES - Library Books	3,054	3,975	3,889	4,000	4,000													
151	SES - Other Library Supplies	448	600	588	600	600													
140	SES - Newspaper/Magazines	146	199	225	200	200													
280	SES - Professional Library	150	196	233	200	200													
282	MA - Professional Library	71	100	98	100	100													
134	MA - Rebinding	112	150	146	150	150													
138	MA - Library Books	748	999	1,000	1,000	1,000													
153	MA - Other Library Supplies	225	300	300	300	300													
142	MA - Newspaper/Magazines	298	400	400	400	400													
154	HS - Other Library Supplies	238	299	309	300	300													
143	HS - Newspapers/Magazines	533	681	602	700	700													
135	HS - Rebinding	106	144	150	150	150													
139	HS - Library Books	3,721	4,996	4,990	5,000	5,000													
283	HS - Professional Library	0	100	110	125	125													
284	CO - Professional Library	0	130	90	300	300													
810	CO - Newspapers/Magazines	80	90	0	125	125													
1069	SpEd - Professional Library	47	56	0	100	100													
286	SW Media - Professional Library	0	0	0	0	0													
	Library Books	9,977	13,415	13,130	13,750	13,750	13,750	13,750	13,750	13,750	13,750	13,750	13,750	13,750	13,750	0	0.00%		
144	SES - A. V. Materials	383	507	496	500	500													
1151	MA - A. V. Materials	150	200	181	200	200													
147	HS - A. V. Materials	532	711	516	700	700													
150	SW - Computer Software	8,409	8,086	12,443	8,200	8,200													
149	SW - A. V. Materials	510	456	800	800	800													
	Technology	9,984	9,960	14,436	10,400	10,400	10,400	10,400	10,400	10,400	10,400	10,400	10,400	10,400	10,400	0	0.00%		
155	SES - General Supplies	19,511	22,182	21,600	21,800	21,800													
157	MA - General Supplies	4,493	5,648	5,088	5,100	5,100													
159	HS - General Supplies	7,812	9,341	8,469	8,500	8,500													
873	SW - General Computer Supplies	6,764	8,869	8,970	9,000	9,000													
160	SpEd - General Supplies	300	355	265	400	400													
	General Supplies	38,880	46,395	44,392	44,800	44,800	44,800	44,800	44,800	44,800	44,800	44,800	44,800	44,800	44,800	0	0.00%		
771	SES - First Grade Supplies	228	269	350	350	350													
799	SES - Second Grade Supplies	258	401	356	385	385													
846	SES - Third Grade Supplies	222	361	349	405	405													

SOMERS BOARD OF EDUCATION
2014-2015 Budget Planning

Ref #	Description	10-11		11-12		12-13		10-11		11-12		12-13		2013-14		2014-15		Chg 13-14 to 14-15	
		Actual		Actual		Actual		Budget		Budget		Budget		Budget		Proposed		\$	%
904	SES - Remedial Reading Supplies	1,986		1,978		2,000		2,000		2,000		2,000		2,000		2,000		0	
722	SES - Language Arts Supplies	8,729		10,990		10,959		11,040		11,040		11,040		11,040		11,040		0	
187	SES - Math Supplies	1,726		2,347		2,421		2,460		2,460		2,460		2,460		2,460		0	
193	SES - Physical Ed Supplies	588		667		609		700		700		700		700		700		0	
202	SES - Science/Health Supplies	2,934		4,337		4,406		4,460		4,460		4,460		4,460		4,460		0	
208	SES - Social Studies Supplies	2,841		4,513		4,600		4,600		4,600		4,600		4,600		4,600		0	
169	SES - Music Supplies	2,685		4,392		4,403		4,400		4,400		4,400		4,400		4,400		0	
161	SES - Art Supplies	3,148		4,359		4,305		4,350		4,350		4,350		4,350		4,350		0	
1149	SES - Intervention - Math	142		191		143		190		190		190		190		190		0	
1183	SES - Fifth Grade Supplies	296		417		419		420		420		420		420		420		0	
1182	SES - Fourth Grade Supplies	253		378		374		380		380		380		380		380		0	
652	SES - Kindergarten Supplies	540		689		624		700		700		700		700		1,000		300	
230	SES - ALP I Supplies	75		75		82		100		100		100		100		100		0	
217	SES - Speech/Hearing Supplies	113		135		126		170		170		170		170		170		0	
1590	SES - World Language	523		800		799		800		800		800		800		800		0	
747	Preschool - Speech/Hearing Supp.	111		151		94		150		150		150		150		150		0	
224	MA - Guidance Instruction Supplies	416		560		541		560		560		560		560		560		0	
1218	MA - Health & Life Skills Supplies	274		392		400		400		400		400		400		400		0	
189	MA - Math Supplies	937		1,459		1,389		1,450		1,450		1,450		1,450		1,450		0	
194	MA - Physical Ed Supplies	450		441		439		450		450		450		450		450		0	
164	MA - Art Supplies	2,450		2,374		2,393		2,400		2,400		2,400		2,400		2,400		0	
204	MA - Science Supplies	1,756		2,567		2,467		2,500		2,500		2,500		2,500		2,500		0	
210	MA - Social Studies Supplies	1,653		2,171		2,155		2,170		2,170		2,170		2,170		2,170		0	
182	MA - Technology Ed Supplies	3,249		3,454		3,684		3,600		3,600		3,600		3,600		3,600		0	
172	MA - Music Supplies	1,833		2,471		2,479		2,480		2,480		2,480		2,480		2,480		0	
184	MA - Language Arts Supplies	2,677		3,786		3,883		3,900		3,900		3,900		3,900		3,900		0	
816	MA - World Language Supplies	186		280		248		250		250		250		250		250		0	
226	MA - ALP Supplies	75		85		47		100		100		100		100		100		0	
214	MA - Resource Room Supplies	74		115		120		120		120		120		120		120		0	
215	MA - Resource Room Supplies	59		92		126		130		130		130		130		130		0	
213	MA - Alternative Ed Program	147		180		201		200		200		200		200		200		0	
176	HS - Business Ed Supplies	1,413		2,050		1,997		2,050		2,050		2,050		2,050		2,050		0	
206	HS - Science Supplies	7,253		7,219		7,256		7,260		7,260		7,260		7,260		7,260		0	
186	HS - Reading Supplies	284		500		180		500		500		500		500		500		0	
168	HS - Band Supplies	1,349		1,842		1,849		1,850		1,850		1,850		1,850		1,850		0	
191	HS - Math Supplies	2,400		3,200		3,200		3,200		3,200		3,200		3,200		3,200		0	
183	HS - Technology Ed Supplies	6,376		14,676		6,343		6,400		6,400		6,400		6,400		6,400		0	
181	HS - Quantity Foods Supplies	4,018		4,282		4,346		4,250		4,250		4,250		4,250		4,250		0	
178	HS - Guidance Supplies	1,316		1,916		1,950		1,950		1,950		1,950		1,950		1,950		0	
165	HS - Art Supplies	7,296		7,311		7,346		7,300		7,300		7,300		7,300		7,300		0	
195	HS - Physical Ed Supplies	1,499		1,496		1,500		1,500		1,500		1,500		1,500		1,500		0	
1070	HS - English Supplies	1,936		2,650		2,650		2,650		2,650		2,650		2,650		2,650		0	
180	HS - SAT Prep	305		2,350		2,350		2,350		2,350		2,350		2,350		2,350		0	
809	HS - Renaissance	546		598		524		750		750		750		750		750		0	
173	HS - College Connections	0		0		0		0		0		0		0		0		0	
286	HS - Guidance Naviance	2,102		6,572		2,300		2,300		2,300		2,300		2,300		2,300		700	
229	HS - School-to-Career Supplies	579		669		686		700		700		700		700		700		0	
231	HS - ALP I Supplies	159		220		24		220		220		220		220		220		0	
1644	HS - Social Studies Supplies	713		1,120		1,115		1,120		1,120		1,120		1,120		1,120		0	
175	HS - World Language	289		350		330		350		350		350		350		350		0	

**SOMERS BOARD OF EDUCATION
2014-2015 Budget Planning**

Ref #	Description	10-11 Actual	11-12 Actual	12-13 Actual	10-11 Budget	11-12 Budget	12-13 Budget	2013-14 Budget	2014-15 Proposed	Chg 13-14 to 14-15 \$	%
721	HS - Health Ed Supplies	474	550	540	550	550	550	550	550	0	0
222	SW - A. V. Supplies	2,151	2,598	2,600	2,600	2,600	2,600	2,600	2,600	0	0
860	SW - Intervention Supplies	210	210	210	210	210	210	210	210	0	0
852	SW - Math Supplies	374	400	400	400	400	400	400	400	0	0
1150	SW - Science Supplies	310	400	400	400	400	400	400	400	0	0
232	SW - Gifted & Talented Supplies	368	472	489	490	490	490	490	490	0	0
219	SW - Speech/Hearing Supplies	147	146	211	200	200	200	200	200	0	0
225	SW - Social Work Supplies	187	190	246	250	250	250	250	250	0	0
1332	SW - Occ Therapy Supplies	114	189	181	180	180	180	180	180	0	0
1333	SW - Physical Therapy Supplies	151	182	198	200	200	200	200	200	0	0
179	SW - Literacy Supplies	92	100	100	100	100	100	100	100	0	0
1071	SW - English Supplies	100	100	100	100	100	100	100	100	0	0
1027	SW - School Psychology Supplies	300	375	447	450	450	450	450	450	0	0
228	SpEd - K-5 ALP A Supplies	122	160	116	160	160	160	160	160	0	0
882	SpEd - E.S.L. Supplies	0	0	30	40	40	40	40	40	0	0
1073	SpEd - Preschool Supplies	83	119	151	150	150	150	150	150	0	0
216	SpEd - High School Supplies	141	199	0	200	200	200	200	200	0	0
212	SpEd - K-5 Supplies	141	157	118	190	190	190	190	190	0	0
1334	SpEd - Intervention Programs	135	174	166	180	180	180	180	180	0	0
1643	SpEd - SHS Rebuilding Program	280	124	350	390	390	390	390	390	0	0
	Departmental Supplies	89,347	123,743	110,990	112,910	112,910	112,910	112,910	113,910	1,000	0.89%
244	SES - Social Studies Workbooks		0	0	0	0	0	0	0	0	0
240	SES - Language Arts Workbooks		0	0	0	0	0	0	0	0	0
238	SES - Math Workbooks	8,952	20,232	19,247	8,375	20,375	20,375	20,375	20,375	0	0
255	MA - World Language Workbooks	1,215	1,614	1,621	1,620	1,620	1,620	1,620	1,620	0	0
246	MA - English Workbooks	364	539	494	500	500	500	500	500	0	0
247	MA - Reading Workbooks		0	0	0	0	0	0	0	0	0
1074	MA - Social Studies Workbooks	495	660	636	660	660	660	660	660	0	0
887	HS - Social Studies Workbooks	402	550	527	550	550	550	550	550	0	0
972	HS - Health Workbooks	299	387	400	400	400	400	400	400	0	0
1581	HS - World Language	995	1,600	1,587	1,600	1,600	1,600	1,600	1,600	0	0
247	HS - Music Workbooks	188	248	250	250	250	250	250	250	0	0
252	SW - Testing	4,848	4,817	22,325	5,000	5,000	5,000	5,000	5,000	0	0
1002	SpEd - Testing	2,560	4,257	3,984	3,985	3,985	3,985	3,985	3,985	0	0
	Workbooks	20,318	34,904	51,071	22,940	34,940	34,940	34,940	34,940	0	0.00%
259	SES - In-Service/Travel	3,354	2,531	1,796	2,200	2,200	2,200	2,200	2,200	0	0
260	SES - Principal In-Service/Travel	255	897	79	1,000	1,000	1,000	1,000	1,000	0	0
263	MA - In-Service/Travel	420	962	1,093	1,000	1,000	1,000	1,000	1,000	0	0
264	MA - Principal In-Service/Travel	31	1,092	990	800	800	800	800	800	0	0
269	HS - Principal In-Service/Travel	1,176	852	1,149	1,000	1,000	1,000	1,000	1,000	0	0
267	HS - In-Service/Travel	2,590	3,111	1,830	2,350	2,350	2,350	2,350	2,350	0	0
300	Curriculum Development	3,402	6,675	15,479	6,700	6,700	16,700	16,700	16,700	0	0
297	CO - Administration Workshop	0	0	0	500	500	500	500	500	0	0
271	CO - In-Service/Travel	1,622	3,306	2,063	3,500	3,500	3,500	3,500	3,500	0	0
857	SW - Custodial Training	0	0	0	0	0	0	0	0	0	0
272	SpEd - In-Service/Travel	345	458	254	500	500	500	500	500	0	0

SOMERS BOARD OF EDUCATION
2014-2015 Budget Planning

Ref #	Description	10-11		11-12		12-13		10-11		11-12		12-13		2013-14		2014-15		Chg 13-14 to 14-15	
		Actual	Budget	Actual	Budget	Actual	Budget	Budget	Budget	Budget	Budget	Budget	Budget	Budget	Proposed	Budget	\$	%	
273	SpEd Director - In-Service/Travel	1,548	1,800	819	1,771	1,771	1,800	1,800	1,800	1,800	1,800	1,800	1,800	1,800	1,800	0	0		
	In-Service/Travel	14,743	21,350	20,703	21,350	26,504	21,350	21,350	21,350	31,350	31,350	31,350	31,350	31,350	31,350	0	0.00%		
301	SES - Office Supplies	428	700	698	722	722	700	700	700	700	700	700	700	700	700	0			
303	MA - Office Supplies	525	700	700	699	699	700	700	700	700	700	700	700	700	700	0			
304	HS - Office Supplies	925	1,250	1,246	1,259	1,259	1,250	1,250	1,250	1,250	1,250	1,250	1,250	1,250	1,250	0			
305	SW - Media Office Supplies	0	175	150	163	163	175	175	175	175	175	175	175	175	175	0			
44	CO - Computer Supplies	1,251	1,500	1,929	1,435	1,435	1,500	1,500	1,500	1,500	1,500	1,500	1,500	1,500	1,500	0			
42	CO - Office Supplies	4,145	4,500	5,007	4,230	4,230	4,500	4,500	4,500	4,500	4,500	4,500	4,500	4,500	4,500	0			
306	Maintenance - Office Supplies	18	50	478	0	0	50	50	50	50	50	50	50	50	50	0			
307	SpEd - Office Supplies	246	350	348	237	237	350	350	350	350	350	350	350	350	350	0			
	Office Supplies	7,538	9,225	10,556	8,745	8,745	9,225	9,225	9,225	9,225	9,225	9,225	9,225	9,225	9,225	0	0.00%		
313	SW - Medical Advisor	500	500	500	500	500	500	500	500	500	500	500	500	500	500	0			
	Medical Advisor Salary	500	500	500	500	500	500	500	500	500	500	500	500	500	500	0	0.00%		
316	SES - Nurse Salaries	61,342	61,333	41,849	46,537	46,537	61,333	61,333	61,333	61,333	61,333	45,300	45,300	52,330	72,354	20,024			
317	MA - Nurse Salary	40,242	40,242	39,942	41,023	41,023	40,242	40,242	40,242	40,242	40,242	40,823	40,823	41,819	41,819	0			
318	HS - Nurse Salary	49,420	49,420	49,120	59,615	59,615	49,420	49,420	49,420	49,420	49,420	61,000	61,000	35,800	35,800	0			
319	SW - Nurse Substitute	1,587	3,000	4,722	4,878	4,878	3,000	3,000	3,000	3,000	3,000	3,000	3,000	3,000	3,000	0			
314	SW - Head Nurse	2,200	2,200	2,200	2,200	2,200	2,200	2,200	2,200	2,200	2,200	2,200	2,200	2,200	2,200	0			
833	SW - Additional Nurse Time	4,045	2,100	2,395	4,269	4,269	2,100	2,100	2,100	2,100	2,100	2,100	2,100	2,100	2,100	0			
	Nurses Salaries	158,836	158,295	140,228	158,522	158,522	158,295	158,295	158,295	158,295	154,423	154,423	137,249	157,273	157,273	20,024	14.59%		
1146	SW - Health Supplies	4,149	6,000	5,897	5,984	5,984	6,000	6,000	6,000	6,000	6,000	6,000	6,000	6,000	6,000	0			
1076	SW - Health Equipment	706	1,000	987	895	895	1,000	1,000	1,000	1,000	1,000	1,000	1,000	1,000	1,000	0			
	Health Supplies	4,855	7,000	6,884	6,879	6,879	7,000	7,000	7,000	7,000	7,000	7,000	7,000	7,000	7,000	0	0.00%		
327	Bus Fuel	83,344	94,000	105,243	107,378	107,378	94,000	94,000	94,000	114,000	114,000	114,000	114,000	114,000	114,000	0			
326	Transportation - Secondary	280,631	280,600	294,774	292,019	292,019	280,600	280,600	294,300	294,300	300,200	300,200	290,000	298,400	298,400	8,400			
325	Transportation - Elementary	231,531	231,500	243,188	242,582	242,582	231,500	231,500	242,800	242,800	247,600	247,600	243,000	250,000	250,000	7,000			
328	Additional Transportation	8,400	3,000	8,286	0	0	3,000	3,000	3,000	3,000	3,000	3,000	3,000	3,000	3,000	0			
1582	Bus Monitor	0	0	0	0	0	0	0	0	0	0	0	0	0	0	0			
	Regular Transportation	603,906	609,100	651,491	641,979	641,979	609,100	609,100	654,100	654,100	664,800	664,800	650,000	665,400	665,400	15,400	2.37%		
333	SpEd - Transportation Aide	42,301	60,900	40,047	38,432	38,432	60,900	60,900	46,666	46,666	47,600	47,600	42,000	43,200	43,200	1,200			
332	SpEd - Additional Mileage	59,300	38,480	54,644	68,897	68,897	38,480	38,480	38,480	38,480	38,480	38,480	38,480	38,480	38,480	0			
329	SpEd - Vans	189,431	189,400	198,972	194,502	194,502	189,400	189,400	198,700	198,700	202,700	202,700	194,000	199,600	199,600	5,600			
	Special Ed Transportation	291,032	288,780	293,663	301,831	301,831	288,780	288,780	283,846	283,846	288,780	288,780	274,480	281,280	281,280	6,800	2.48%		
336	MA - Athletic Trips	315	700	885	1,035	1,035	700	700	700	700	700	700	700	700	700	0			
340	MA - Band Travel	0	0	0	0	0	0	0	0	0	0	0	0	0	0	0			
337	HS - Athletic Trips	12,304	28,500	18,050	21,814	21,814	28,500	28,500	29,427	29,427	29,427	29,427	42,000	43,200	43,200	1,200			

**SOMERS BOARD OF EDUCATION
2014-2015 Budget Planning**

Ref #	Description	10-11		11-12		12-13		10-11		11-12		12-13		2013-14		2014-15		Chg 13-14 to 14-15		
		Actual		Actual		Actual		Budget		Budget		Budget		Budget		Proposed		\$	%	
268	HS - Band Travel	833		921		1,226		1,230		1,230		1,230		1,230		1,230		1,230		0
845	HS - Field Trips	908		1,405		1,947		1,550		1,550		1,550		1,550		1,550		1,550		0
338	Pay to Play	0		0		0		-20,000		-20,000		-20,000		-20,000		-20,000		-20,000		0
	Athletic/Band/Academic Travel	14,360		21,261		26,022		11,980		12,907		12,907		25,480		26,680		1,200		4.71%
350	Maintenance Personnel	83,802		83,802		85,573		83,802		83,802		85,573		87,285		87,285		87,285		0
349	Maintenance Supervisor	62,537		64,093		65,847		63,782		63,782		65,369		67,650		67,650		67,650		0
348	Custodial Substitutes	24,130		22,299		28,663		20,773		20,773		20,773		20,773		20,773		20,773		0
351	Summer Crew Maintenance	4,136		3,742		5,577		3,310		3,310		5,500		5,500		5,500		5,500		0
352	Maintenance Overtime	6,154		5,666		3,887		7,000		7,000		7,000		7,000		7,000		7,000		0
343	SES - Custodian Salaries	152,184		152,184		145,203		152,184		152,184		157,551		156,131		156,131		156,131		0
344	MA - Custodian Salaries	143,521		150,053		156,006		149,843		149,843		156,332		160,520		160,520		160,520		0
345	Recreation Program	4,686		4,500		4,536		4,500		4,500		4,500		4,500		4,500		4,500		0
346	HS - Custodian Salaries	132,225		137,461		154,565		150,887		150,887		153,045		150,406		150,406		150,406		0
347	Custodial Overtime	14,541		10,542		10,276		10,000		10,000		10,000		10,000		10,000		10,000		0
877	SW - Asbestos Stipend	0		0		0														0
	06-07 UFCW Contract Retro Pay	0		0		0														0
	Maint/Custodian Salaries	627,916		634,342		660,133		646,081		646,081		665,643		669,765		669,765		669,765		0.00%
354	SES - Fuel #2	72,484		98,499		91,162		75,000		95,500		95,500		99,000		99,000		99,000		0
356	HS - Fuel #2	90,086		94,789		119,922		83,000		113,300		113,300		118,000		118,000		118,000		0
357	Maintenance - Fuel #2	1,660		2,220		1,996		2,000		2,200		2,200		2,200		2,200		2,200		0
	Fuel Supply	164,230		195,508		213,080		160,000		211,000		211,000		219,200		219,200		219,200		0.00%
361	HS - Electricity	130,084		121,886		122,722		142,500		130,000		125,000		120,000		120,000		120,000		0
360	MA - Electricity	147,876		119,915		137,353		148,900		140,000		140,000		140,000		140,000		140,000		0
358	SES - Electricity	82,022		82,887		87,235		96,900		90,000		80,000		85,000		85,000		85,000		0
362	Maintenance - Electricity	2,314		2,072		1,963		2,835		2,977		2,977		2,977		2,977		2,977		0
1335	MA - Projected Electricity Savings	0		0		0														0
	Electricity	362,296		326,760		349,273		391,135		362,977		347,977		347,977		347,977		347,977		0.00%
363	SES - Telephone	4,300		4,368		4,309		3,800		3,800		3,800		3,800		3,800		3,800		0
365	MA - Telephone	2,145		2,322		2,679		1,800		1,800		1,800		1,800		1,800		1,800		0
366	HS - Telephone	4,984		5,298		4,760		5,500		5,500		5,500		5,500		5,500		5,500		0
965	HS - Cable Classroom Internet	0		0		0		0		0		0		0		0		0		0
367	CO - Telephone	5,779		6,009		5,886		5,500		5,500		5,500		5,500		5,500		5,500		0
1217	SW - Communication Supplies	5,441		14,392		9,466		5,800		5,800		5,800		5,800		5,800		5,800		0
	Telephone	22,649		32,389		27,100		22,400		22,400		22,400		22,400		22,400		22,400		0.00%
372	HS - Propane Gas	2,666		3,064		2,610		3,000		3,000		3,000		3,000		3,000		3,000		0
371	MA - Propane Gas	5,215		6,692		2,495		3,000		3,000		3,000		3,000		3,000		3,000		0
369	SES - Propane Gas	2,442		4,741		3,290		5,000		5,000		5,000		5,000		5,000		5,000		0
	Propane Gas	10,323		14,497		8,395		11,000		11,000		11,000		11,000		11,000		11,000		0.00%

**SOMERS BOARD OF EDUCATION
2014-2015 Budget Planning**

Ref #	Description	10-11		11-12		12-13		10-11		11-12		12-13		2013-14		2014-15		Chg 13-14 to 14-15	
		Actual	Budget	Actual	Budget	Actual	Budget	Budget	Budget	Budget	Budget	Budget	Budget	Budget	Proposed	\$	%		
377	SW - Custodial Supplies	41,083	44,899	44,559	45,000	44,559	45,000	45,000	45,000	45,000	45,000	45,000	45,000	45,000					
	Custodial Supplies	41,083	44,899	44,559	45,000	44,559	45,000	45,000	45,000	45,000	45,000	45,000	45,000	45,000			0	0.00%	
378	SES - Music Maintenance	0	176	100	100	100	100	100	100	100	100	100	100	100			0		
1141	SES - Building Repairs	34,967	42,299	35,290	13,000	35,290	13,000	13,000	13,000	13,000	13,000	16,000	16,000	50,000			35,000	-15,000	
409	MA - Equipment Maintenance	83	100	0	100	0	100	100	100	100	100	100	100	100			100	0	
382	MA - Music Maintenance	100	210	300	300	300	300	300	300	300	300	300	300	300			300	0	
383	MA - Science Maintenance	0	200	200	200	200	200	200	200	200	200	200	200	200			200	0	
384	MA - Art Maintenance	0	0	0	300	0	300	300	300	300	300	300	300	300			300	0	
385	MA - Home Ec Maintenance	100	100	100	100	100	100	100	100	100	100	100	100	100			100	0	
386	MA - Band Maintenance	374	502	496	500	496	500	500	500	500	500	500	500	500			500	0	
387	MA - Technology Ed Maintenance	195	2,499	600	600	600	600	600	600	600	600	600	600	600			600	0	
389	MA - Office Equip. Maintenance	64	100	100	100	100	100	100	100	100	100	100	100	100			100	0	
840	SW - Trailer Rental	0	0	0	0	0	0	0	0	0	0	0	0	0			0	0	
416	HS - Library Equipment Maintenance	0	0	0	0	0	0	0	0	0	0	0	0	0			0	0	
433	HS - Scheduling Service	0	0	3,000	1,700	3,000	1,700	1,700	1,700	1,700	1,700	1,700	1,700	1,700			1,700	0	
390	HS - Science Maintenance	0	1,175	1,175	1,175	1,175	1,175	1,175	1,175	1,175	1,175	1,175	1,175	1,175			1,175	0	
391	HS - Art Maintenance	0	85	0	200	0	200	200	200	200	200	200	200	200			200	0	
393	HS - Quantity Foods Maintenance	2,961	3,254	10,993	3,775	10,993	3,775	3,775	3,775	3,775	3,775	3,775	3,775	3,775			3,775	0	
394	HS - Athletics Maintenance	0	0	0	300	0	300	300	300	300	300	300	300	300			300	0	
395	HS - Technology Ed Maintenance	3,619	10,147	3,715	3,900	3,715	3,900	3,900	3,900	3,900	3,900	3,900	3,900	3,900			3,900	0	
396	HS - Music Maintenance	559	665	800	800	800	800	800	800	800	800	800	800	800			800	0	
403	HS - Office Equipment	0	200	0	200	0	200	200	200	200	200	200	200	200			200	0	
398	HS - Math Maintenance	0	0	0	200	0	200	200	200	200	200	200	200	200			200	0	
341	SW - Gasoline Maint. Vehicles	7,207	6,888	8,452	4,500	8,452	4,500	4,500	4,500	4,500	4,500	4,500	4,500	7,500			7,500	0	
452	SW - Maintenance Contracts	39,437	38,396	49,458	45,340	49,458	45,340	45,340	45,340	45,340	45,340	45,340	45,340	45,340			45,340	0	
467	SW - General Paint	3,067	6,584	4,832	3,500	4,832	3,500	3,500	3,500	3,500	3,500	3,500	3,500	3,500			3,500	0	
471	SW - Fire Alarms & Bells	1,659	1,226	6,860	2,500	6,860	2,500	2,500	2,500	2,500	2,500	2,500	2,500	2,500			2,500	0	
438	HS - Septic Tank	2,790	5,940	2,740	2,900	2,740	2,900	2,900	2,900	2,900	2,900	2,900	2,900	2,900			2,900	0	
439	HS - Building Maintenance	36,814	54,097	31,178	19,400	31,178	19,400	19,400	19,400	19,400	19,400	19,400	19,400	30,000			40,000	10,000	
440	SW - Equipment Repair	8,356	8,434	11,314	7,700	11,314	7,700	7,700	7,700	7,700	7,700	7,700	7,700	7,700			7,700	0	
445	SW - Tool Supply	1,242	4,277	3,054	2,000	3,054	2,000	2,000	2,000	2,000	2,000	2,000	2,000	2,000			2,000	0	
444	SW - Rubbish Removal	14,336	14,396	14,425	15,000	14,425	15,000	15,000	15,000	15,000	15,000	15,000	15,000	15,000			15,000	0	
442	SW - Grounds Keep	8,283	17,138	11,953	8,000	11,953	8,000	8,000	8,000	8,000	8,000	8,000	8,000	8,000			8,000	0	
447	SW - General Repair	4,294	5,166	7,100	5,000	7,100	5,000	5,000	5,000	5,000	5,000	5,000	5,000	5,000			5,000	0	
448	SW - Fire/Vandalism	883	920	238	1,500	238	1,500	1,500	1,500	1,500	1,500	1,500	1,500	1,500			1,500	0	
451	SW - Mower Maintenance	2,249	11,992	3,179	12,000	3,179	12,000	12,000	12,000	12,000	12,000	12,000	12,000	12,000			12,000	0	
654	SW - Asbestos Inspection	540	0	250	600	250	600	600	600	600	600	600	600	600			600	0	
886	SW - Plumbing Supplies	4,691	1,374	1,408	2,500	1,408	2,500	2,500	2,500	2,500	2,500	2,500	2,500	2,500			2,500	0	
885	SW - Electrical Supplies	2,818	5,335	7,626	4,000	7,626	4,000	4,000	4,000	4,000	4,000	4,000	4,000	4,000			4,000	0	
801	SW - Exterminating	2,966	3,261	2,830	2,200	2,830	2,200	2,200	2,200	2,200	2,200	2,200	2,200	2,200			2,200	0	
884	Maint - Building Maintenance	0	428	473	750	473	750	750	750	750	750	750	750	750			750	0	
657	SW - Playground Maintenance	1,557	1,557	2,284	1,500	2,284	1,500	1,500	1,500	1,500	1,500	1,500	1,500	1,500			1,500	0	
430	MA - Building Maintenance	22,952	25,574	26,454	8,700	26,454	8,700	8,700	8,700	8,700	8,700	8,700	8,700	19,000			24,000	5,000	
422	SES - Septic Tank	5,815	1,960	5,640	3,000	5,640	3,000	3,000	3,000	3,000	3,000	3,000	3,000	3,000			3,000	0	
373	SW - Water	25,693	29,774	27,264	23,000	27,264	23,000	23,000	23,000	23,000	23,000	23,000	23,000	25,300			25,300	0	
404	SW - A.V. Maintenance	3,522	5,249	4,377	5,300	4,377	5,300	5,300	5,300	5,300	5,300	5,300	5,300	5,300			5,300	0	
412	SW - Health Maintenance	0	0	0	100	0	100	100	100	100	100	100	100	100			100	0	
435	SW - Thermostat/Controls	8,069	2,372	2,921	2,500	2,921	2,500	2,500	2,500	2,500	2,500	2,500	2,500	2,500			2,500	0	

**SOMERS BOARD OF EDUCATION
2014-2015 Budget Planning**

Ref #	Description	10-11		11-12		12-13		10-11		11-12		12-13		2013-14		2014-15		Chg 13-14 to 14-15	
		Actual	Budget	Actual	Budget	Actual	Budget	Budget	Budget	Budget	Budget	Budget	Budget	Budget	Proposed	\$	%		
1077	SW - Computer Maintenance	11,850	12,235	13,220	12,235	0	51	12,000	12,000	12,000	12,000	12,000	12,000	12,000	0				
413	SP ED - Equipment Maintenance	0	0	0	0	0	0	100	100	100	100	100	100	100	0				
1645	SW - Bibliomation	5,225	13,552	9,344	13,552	0	3,600	9,000	9,000	9,000	9,000	9,000	9,000	9,000	0				
1646	SW - Security	0	3,600	0	3,600	0	800	1,500	1,500	1,500	1,500	1,500	1,500	1,500	0				
431	MA - Sepsic Tank	600	800	3,800	800	0	0	2,200	2,200	2,200	2,200	2,200	2,200	2,200	0				
405	K-5 Office Equipment	0	0	0	0	0	0	0	0	0	0	0	0	0	0				
426	MA - Master Clock Maintenance	0	0	0	0	0	0	0	0	0	0	0	0	0	0				
449	SW - Locker Repair	116	272	351	272	0	0	0	0	0	0	0	0	0	0				
441	SW Glass Repair	0	0	0	0	0	0	0	0	0	0	0	0	0	0				
443	SW Roof Repair	9,606	7,341	9,490	7,341	0	0	6,000	6,000	6,000	6,000	6,000	6,000	6,000	0				
446	SW - Trepass Control	0	0	0	0	0	0	0	0	0	0	0	0	0	0				
453	SW - Software Maintenance	21,836	41,300	48,858	41,300	0	0	20,509	36,531	36,531	36,531	36,531	36,531	36,531	0				
1637	Addtl Approp Winter 10-11	0	0	0	0	0	0	28,862	0	0	0	0	0	0	0				
	General Maintenance	301,495	372,530	399,113	372,530			291,211	280,671	283,671	283,671	283,671	341,571	341,571	0			0.00%	
472	SW - AV Equipment	1,111	1,560	3,101	1,560	0	0	1,600	1,600	1,600	1,600	1,600	1,600	1,600	0				
477	SW - Replacement	0	0	0	0	0	0	0	0	0	0	0	0	0	0				
489	SW - Maintenance Replacement	0	0	0	0	0	0	0	0	0	0	0	0	0	0				
616	HS - Tech Ed Replacement	1,160	1,162	1,189	1,162	0	0	1,200	1,200	1,200	1,200	1,200	1,200	1,200	0				
	Equipment Replacement	2,271	2,722	4,290	2,722			2,800	2,800	2,800	2,800	2,800	2,800	2,800	0			0.00%	
507	HS - Athletic Insurance	8,253	9,043	9,212	9,043	0	0	8,600	8,600	8,600	8,600	8,600	8,600	8,200	425				
506	Social Security	348,678	355,499	351,831	355,499	0	0	350,000	350,000	350,000	350,000	350,000	350,000	365,000	2,000				
510	Dental	174,641	165,994	145,237	165,994	0	0	167,200	152,680	173,820	171,200	171,200	171,200	170,900	-300				
512	Life and AD&D Insurance	43,730	25,762	25,732	25,762	0	0	25,000	25,000	25,000	25,000	25,000	25,000	26,200	0				
513	LTD	45,955	44,486	45,398	44,486	0	0	45,600	45,600	45,600	45,600	45,600	45,600	45,000	0				
515	Property/Liability Insurance	46,656	54,419	50,387	54,419	0	0	47,988	50,387	52,906	55,072	55,072	57,800	2,728					
521	School Board Legal	7,260	7,830	7,259	7,830	0	0	7,259	7,259	7,622	8,184	8,184	8,600	416					
520	Umbrella Liability Insurance	11,556	12,026	11,153	12,026	0	0	10,673	10,673	11,207	11,164	11,164	11,700	536					
517	Unemployment Insurance	41,040	25,591	31,436	25,591	0	0	35,000	35,000	35,000	35,000	35,000	35,000	25,000	-10,000				
516	Worker's Compensation	135,089	117,249	104,734	117,249	0	0	88,489	104,700	109,935	81,236	81,236	83,500	2,264					
855	Pension	222,307	209,206	193,405	209,206	0	0	250,000	250,000	250,000	225,000	225,000	255,000	30,000					
1228	SW - HDHP/HAS	57,428	14,696	43,676	14,696	0	0	57,600	42,200	42,200	29,700	29,700	1,548,300	1,518,600					
1185	SW - Health Maintenance Org.	626,022	619,219	671,634	619,219	0	0	676,400	654,100	625,000	631,700	631,700	94,400	-537,300					
1186	SW - Preferred Provided Org.	1,702,830	1,569,957	1,696,492	1,569,957	0	0	1,705,400	1,759,374	1,626,326	1,798,000	1,798,000	779,700	-1,018,300					
1187	SW - Insurance Waivers	90,700	69,243	86,341	69,243	0	0	91,200	88,400	69,000	45,000	45,000	46,100	1,100					
508	Tax Sheltered Annuities/Other Benefits	29,752	29,418	29,146	29,418	0	0	22,500	29,100	29,100	29,700	29,700	29,700	0					
511	SW - Pension Waiver	6,875	6,500	6,500	6,500	0	0	8,000	8,000	8,000	8,000	8,000	8,000	8,000	0				
509	SW - Flexible Spending Acct	1,874	2,682	1,741	2,682	0	0	1,700	1,700	1,700	1,700	1,700	1,700	1,700	0				
514	SHS Jan 2004 Ins Claim	0	0	0	0	0	0	0	0	0	0	0	0	0	0				
	Anthem Demutualization	0	0	0	0	0	0	0	0	0	0	0	0	0	0				
	Insurance	3,600,646	3,338,820	3,511,314	3,338,820			3,598,609	3,622,773	3,453,816	3,572,631	3,572,631	3,564,800	-7,831				-0.22%	
1011	SES - Copier Maintenance	6,276	6,262	6,943	6,262	0	0	5,900	5,900	5,900	6,700	6,700	6,700	6,700	0				
523	SES - Copier Rental	7,163	4,838	5,324	4,838	0	0	7,200	7,200	7,200	6,500	6,500	6,500	6,500	0				
524	SES - Copier Supplies	1,809	5,431	1,991	5,431	0	0	2,000	2,000	2,000	1,000	1,000	1,000	1,000	0				
527	IMA - Copier Rental	7,163	4,838	5,323	4,838	0	0	7,200	7,200	7,200	6,500	6,500	6,500	6,500	0				

SOMERS BOARD OF EDUCATION
2014-2015 Budget Planning

Ref #	Description	10-11		11-12		12-13		10-11		11-12		12-13		2013-14		2014-15		Chg 13-14 to 14-15	
		Actual	Budget	Actual	Budget	Actual	Budget	Budget	Budget	Budget	Budget	Budget	Budget	Budget	Proposed	\$	%		
1012	MA - Copier Supplies	1,200	1,500	3,901	1,500	3,901	1,500	1,500	1,500	1,500	1,500	1,500	1,500	1,000	0				
1013	MA - Copier Maintenance	4,104	5,060	3,915	4,400	3,915	4,400	4,400	4,400	4,400	4,400	4,400	4,400	4,700	0				
1188	SpEd - Copier Supplies	0	0	0	0	0	0	0	0	0	0	0	0	0	0				
1014	HS - Copier Supplies	1,807	1,991	5,888	2,000	5,888	2,000	2,000	2,000	2,000	2,000	2,000	2,000	1,000	0				
763	HS - Copier Rental	7,163	5,323	4,838	7,200	4,838	7,200	7,200	7,200	7,200	7,200	7,200	7,200	6,500	0				
1015	HS - Copier Maintenance	7,212	6,501	6,312	7,000	6,312	7,000	7,000	7,000	7,000	7,000	7,000	7,000	7,000	0				
905	SW - Copier Supplies/Maintenance	1,014	1,262	1,334	1,040	1,334	1,040	1,040	1,040	1,040	1,040	1,040	1,040	1,040	0				
861	SW - Desktop Maintenance	0	0	0	0	0	0	0	0	0	0	0	0	0	0				
525	CO - Copier Rental	5,282	5,220	4,838	4,970	4,838	4,970	4,970	4,970	4,970	4,970	4,970	4,970	6,500	0				
526	CO - Postage Meter	420	693	895	1,200	895	1,200	1,200	1,200	1,200	1,200	1,200	1,200	1,200	0				
454	CO - Copier Maintenance	1,115	1,044	791	2,500	791	2,500	2,500	2,500	2,500	2,500	2,500	2,500	2,500	0				
1016	CO - Copier Supplies	492	295	300	300	300	300	300	300	300	300	300	300	300	0				
	Equipment Rental	52,220	48,470	54,381	54,410	54,381	54,410	54,410	54,410	54,410	54,410	54,410	54,410	52,440	0	0.00%			
1078	MA - Intramural Coaches	7,248	7,129	7,115	7,248	7,115	7,248	7,248	7,248	7,248	7,248	7,357	7,468	7,471	3				
805	HS - Golf	3,827	3,827	3,884	3,827	3,884	3,827	3,827	3,827	3,827	3,827	3,884	3,942	3,944	2				
559	HS - Var. Cheerleaders - Winter	1,323	1,323	1,343	1,440	1,343	1,440	1,440	1,440	1,440	1,440	1,462	1,484	1,500	16				
655	HS - JV Lacrosse - Boys	2,497	2,813	2,855	2,813	2,855	2,813	2,813	2,813	2,813	2,855	2,855	2,898	2,899	1				
656	HS - Varsity Lacrosse - Girls	4,012	4,012	4,072	4,012	4,072	4,012	4,012	4,012	4,012	4,072	4,072	4,133	4,135	2				
1178	HS - Varsity Lacrosse - Boys	4,012	4,012	4,072	4,012	4,072	4,012	4,012	4,012	4,012	4,072	4,072	4,133	4,135	2				
545	HS - JV Soccer - Girls	2,497	2,497	2,534	2,813	2,534	2,813	2,813	2,813	2,813	2,855	2,855	2,898	2,899	1				
540	HS - JV Soccer - Boys	2,497	2,497	2,534	2,813	2,534	2,813	2,813	2,813	2,813	2,855	2,855	2,898	2,899	1				
556	HS - Varsity Soccer - Girls	3,567	3,567	3,621	4,012	3,621	4,012	4,012	4,012	4,012	4,072	4,072	4,133	4,135	2				
552	HS - Varsity Soccer - Boys	4,012	4,012	4,072	4,012	4,072	4,012	4,012	4,012	4,012	4,072	4,072	4,133	4,135	2				
541	HS - JV Softball	2,497	2,497	2,855	2,813	2,855	2,813	2,813	2,813	2,813	2,855	2,855	2,898	2,899	1				
553	HS - Varsity Softball	4,012	4,012	4,072	4,012	4,072	4,012	4,012	4,012	4,012	4,072	4,072	4,133	4,135	2				
537	HS - JV Baseball	2,813	2,813	2,855	2,813	2,855	2,813	2,813	2,813	2,813	2,855	2,855	2,898	2,899	1				
547	HS - Varsity Baseball	4,012	4,012	4,072	4,012	4,072	4,012	4,012	4,012	4,012	4,072	4,072	4,133	4,135	2				
542	HS - JV Field Hockey	2,497	2,497	2,534	2,813	2,534	2,813	2,813	2,813	2,813	2,855	2,855	2,898	2,899	1				
550	HS - Varsity Field Hockey	4,012	4,012	4,072	4,012	4,072	4,012	4,012	4,012	4,012	4,072	4,072	4,133	4,135	2				
546	HS - Freshmen Basketball - Boys	4,216	4,292	3,785	4,216	3,785	4,216	4,216	4,216	4,216	4,279	4,279	4,343	4,345	2				
538	HS - JV Basketball - Boys	4,216	4,216	4,279	4,216	4,279	4,216	4,216	4,216	4,216	4,279	4,279	4,343	4,345	2				
539	HS - JV Basketball - Girls	3,729	3,729	3,785	4,216	3,785	4,216	4,216	4,216	4,216	4,279	4,279	4,343	4,345	2				
549	HS - Varsity Basketball - Girls	6,001	6,001	6,091	6,001	6,091	6,001	6,001	6,001	6,001	6,091	6,091	6,182	6,184	2				
548	HS - Varsity Basketball - Boys	6,001	6,001	6,091	6,001	6,091	6,001	6,001	6,001	6,001	6,091	6,091	6,182	6,184	2				
561	HS - Cross Country-Boys/Girls	4,012	4,012	4,072	4,012	4,072	4,012	4,012	4,012	4,012	4,072	4,072	4,133	4,135	2				
554	HS - Varsity Track Head	4,012	3,567	3,621	4,012	3,621	4,012	4,012	4,012	4,012	4,072	4,072	4,133	4,135	2				
560	SW - Athletic Manager	17,523	20,000	20,250	15,523	20,250	20,000	20,000	20,000	20,000	20,300	20,300	20,700	21,250	550				
737	HS - Varsity Track Asst.Girls	2,813	2,497	2,534	2,813	2,534	2,813	2,813	2,813	2,813	2,855	2,855	2,898	2,899	1				
844	HS - JV Lacrosse - Girls	2,497	2,497	2,534	2,813	2,534	2,813	2,813	2,813	2,813	2,855	2,855	2,898	2,899	1				
555	HS - Varsity Wrestling	5,472	5,472	5,554	5,472	5,554	5,472	5,472	5,472	5,472	5,554	5,554	5,637	5,639	2				
1006	Athletic Trainer	20,000	22,500	22,500	20,000	22,500	22,500	22,500	22,500	22,500	22,500	22,500	23,000	23,000	0				
551	HS - Asst Cross Country	2,497	2,497	2,534	2,813	2,534	2,813	2,813	2,813	2,813	2,855	2,855	2,898	2,899	1				
	Coaches	138,324	142,813	143,741	139,585	143,741	146,562	146,562	146,562	146,562	148,419	148,419	150,903	151,511	608	0.40%			
1105	SES - Band Advisor	2,207	2,207	2,240	2,207	2,240	2,207	2,207	2,207	2,207	2,240	2,240	2,274	2,293	19				
1104	SES - Choral Advisor	1,682	1,682	1,707	1,682	1,707	1,682	1,682	1,682	1,682	1,707	1,707	1,733	1,748	15				
	SES - Student Council	0	0	0	0	0	0	0	0	0	0	0	0	0	0				

SOMERS BOARD OF EDUCATION
2014-2015 Budget Planning

Ref #	Description	10-11		11-12		12-13		10-11		11-12		12-13		2013-14		2014-15		Chg 13-14 to 14-15	
		Actual	Budget	Actual	Budget	Actual	Budget	Budget	Budget	Budget	Budget	Budget	Budget	Budget	Budget	Budget	Budget	Budget	\$
1190	MA - Drama Club	2,405	2,405	2,441	2,405	2,441	2,405	2,405	2,405	2,441	2,441	2,478	2,478	3,675	3,675	1,197	1,197		
1191	MA - Newspaper Advisor	730	730	741	730	741	730	810	810	822	822	834	834	841	841	7	7		
1189	MA - Beta Club	730	730	741	730	741	730	730	730	741	741	752	752	758	758	6	6		
1003	MA - Student Government	1,216	1,216	1,234	1,216	1,234	1,216	1,216	1,216	1,234	1,234	1,253	1,253	1,264	1,264	11	11		
586	MA - Band Advisor	0	0	0	0	0	0	873	873	885	885	897	897	905	905	8	8		
1100	MA - Parade Advisor	582	582	590	582	590	582	860	860	873	873	886	886	893	893	7	7		
564	MA - Yearbook	860	860	873	860	873	860	730	730	741	741	752	752	758	758	6	6		
1578	MA - Gateways	730	730	741	730	741	730	730	730	741	741	752	752	758	758	6	6		
562	MA - Chess	730	730	741	730	741	730	730	730	741	741	752	752	758	758	6	6		
563	MA - Tech	730	730	741	730	741	730	730	730	741	741	752	752	758	758	6	6		
565	MBA - Cross Country	0	0	0	0	0	0	730	730	741	741	752	752	758	758	6	6		
584	HS - FBLA	730	730	741	730	741	730	1,117	1,117	1,421	1,421	1,442	1,442	1,454	1,454	12	12		
568	HS - Freshmen	1,117	1,117	1,421	1,117	1,421	1,117	1,117	1,117	1,421	1,421	1,442	1,442	1,454	1,454	12	12		
569	HS - Sophomores	0	0	1,421	0	1,421	0	1,283	1,283	1,646	1,646	1,671	1,671	1,685	1,685	14	14		
570	HS - Juniors	0	0	1,726	0	1,726	0	2,405	2,405	2,441	2,441	2,478	2,478	3,325	3,325	28	28		
571	HS - Seniors	0	2,100	0	2,100	0	0	1,898	1,898	2,132	2,132	2,164	2,164	2,572	2,572	820	820		
572	HS - Drama/Music	0	0	0	0	0	0	2,405	2,405	2,441	2,441	2,478	2,478	3,675	3,675	1,511	1,511		
574	HS - Honor Society	1,053	1,053	0	1,053	0	1,053	730	730	741	741	752	752	1,094	1,094	9	9		
575	HS - SADD Advisor	730	730	741	730	741	730	1,622	1,622	1,646	1,646	1,671	1,671	1,685	1,685	14	14		
576	HS - Student Council	0	1,622	0	1,622	0	0	2,652	2,652	3,248	3,248	3,297	3,297	3,325	3,325	28	28		
577	HS - Yearbook	0	0	0	0	0	0	730	730	741	741	752	752	758	758	6	6		
1173	HS - Math Team	730	730	741	730	741	730	730	730	741	741	752	752	758	758	6	6		
1174	HS - SSS	730	1,100	1,117	730	1,117	730	730	730	741	741	752	752	1,144	1,144	10	10		
1175	HS - Big Brothers /Big Sisters	730	730	741	730	741	730	569	569	578	578	587	587	592	592	5	5		
1172	HS - Jets	569	569	0	569	0	0	1,455	1,455	1,475	1,475	1,495	1,495	1,508	1,508	13	13		
1101	HS - Parade Advisor	0	1,164	885	1,164	885	1,164	1,269	1,269	1,287	1,287	1,305	1,305	1,316	1,316	11	11		
582	HS - Literary Magazine Advisor	1,692	1,692	1,716	1,692	1,716	1,692	1,785	1,785	1,812	1,812	1,839	1,839	1,854	1,854	15	15		
944	HS - Student Caf� Advisor	0	0	0	0	0	0	730	730	741	741	752	752	758	758	6	6		
588	HS - Beta	730	730	741	730	741	730	730	730	741	741	752	752	758	758	6	6		
589	HS - FCCLA	730	730	741	730	741	730	730	730	741	741	752	752	758	758	6	6		
590	HS - Tech	0	730	741	0	741	0	730	730	741	741	752	752	758	758	6	6		
1103	HS - Jazz Ensemble	0	0	0	0	0	0	730	730	741	741	752	752	758	758	6	6		
580	HS - Diversity Coalition	0	0	741	0	741	0	730	730	741	741	752	752	758	758	6	6		
578	HS - GSA Alliance	730	730	741	730	741	730	1,947	1,947	1,976	1,976	2,006	2,006	2,023	2,023	17	17		
975	HS - Newspaper	0	0	1,976	0	1,976	0	-14,000	-14,000	-14,000	-14,000	-14,000	-14,000	-14,000	-14,000	0	0		
567	Pay to Park	0	0	0	0	0	0	-14,000	-14,000	-14,000	-14,000	-14,000	-14,000	-14,000	-14,000	0	0		
	Activity Advisors	22,873	27,012	29,721	26,445	29,721	26,445	26,445	26,445	29,184	29,184	29,828	29,828	34,847	34,847	5,019	16.83%		
596	MA - Officials	159	80	162	159	162	159	1,500	1,500	1,500	1,500	1,500	1,500	1,500	1,500	0	0		
594	MA - Athletic Supplies	1,072	1,499	1,529	1,072	1,529	1,072	100	100	100	100	100	100	100	100	0	0		
600	MA - Athletic Awards	68	62	100	68	100	68	250	250	250	250	250	250	250	250	0	0		
849	MA - Academic Awards	191	272	243	191	243	191	12,000	12,000	12,000	12,000	12,000	12,000	12,000	12,000	0	0		
595	HS - Athletic Supplies	12,467	12,793	11,966	12,467	11,966	12,467	25,400	25,400	26,400	26,400	27,500	27,500	27,500	27,500	0	0		
597	HS - Officials	26,467	25,919	29,687	26,467	29,687	26,467	2,500	2,500	2,500	2,500	2,500	2,500	2,500	2,500	0	0		
602	HS - Academic Awards	2,790	2,214	2,041	2,790	2,041	2,790	1,900	1,900	1,900	1,900	1,900	1,900	1,900	1,900	0	0		
601	HS - Athletic Awards	2,116	1,971	1,845	2,116	1,845	2,116	5,000	5,000	5,000	5,000	5,000	5,000	5,000	5,000	0	0		
1220	HS - Athletic Uniforms	7,572	9,698	4,927	7,572	4,927	7,572	17,200	17,200	17,200	17,200	16,600	16,600	18,600	18,600	2,000	2,000		
1583	HS - Co-op/Unified Sports	0	0	0	0	0	0	5,100	5,100	5,100	5,100	5,100	5,100	5,100	5,100	0	0		
274	HS - Graduation	4,873	4,586	5,128	4,873	5,128	4,873	266	266	266	266	266	266	266	266	0	0		

**SOMERS BOARD OF EDUCATION
2014-2015 Budget Planning**

Ref #	Description	10-11		11-12		12-13		10-11		11-12		12-13		2013-14		2014-15		Chg 13-14 to 14-15	
		Actual	Budget	Actual	Budget	Actual	Budget	Budget	Budget	Budget	Budget	Budget	Budget	Budget	Budget	Budget	Budget	Budget	\$
	Athletic/Academic Activities	57,775	59,094	74,828	54,016	55,016	71,616	72,716	74,716									2,000	2.75%
603	SES - Capital Outlay	1,233	1,700	1,700	1,700	1,700	1,700	1,700	1,700									0	
818	MA - Capital Outlay	363	500	27,170	500	500	500	500	500									0	
1335	MA - Tech Ed Capital Outlay		0	25,376			25,000	25,000	24,000									-1,000	
607	HS - Capital Outlay	2,182	15,263	29,821	2,600	2,600	2,600	2,600	2,600									0	
965	HS - Tech Ed Capital Outlay		0	51,861			52,100	52,100	50,100									-2,000	
614	CO - Capital Outlay	2,224	3,656	0	4,300	4,300	4,300	4,300	4,300									0	
748	SpEd - Capital Outlay Office	0	741	1,843	370	370	370	370	370									0	
843	SW - Capital Outlay Technology	0	13,289	124,844	0	0	110,000	110,000	110,000									0	
618	SW - Build & Grounds Cap Out	0	0	0	0	0	0	0	0									0	
	Capital Outlay	6,002	35,149	262,615	9,470	9,470	196,570	196,570	193,570									-3,000	-1.53%
1231	Tuition - Non Special Education	15,362	39,324	54,191	14,500	14,500	55,000	55,000	119,000									0	
	Tuition Non Special Ed	15,362	39,324	54,191	14,500	14,500	55,000	55,000	119,000									0	0.00%
621	Tuition - Vo Ag	23,976	23,976	7,992	22,500	22,500	8,000	8,000	8,000									0	
	Tuition Vo Ag	23,976	23,976	7,992	22,500	22,500	8,000	8,000	8,000									0	0.00%
622	SpEd - CREC	87,993	134,921	95,785	130,000	130,000	130,000	140,000	140,000									0	
634	SpEd - CREC Polaris	0	0	0	0	0	0	63,000	63,000									0	
1079	OT/PT	63,974	72,146	76,320	72,752	72,752	72,752	74,200	75,700									1,500	
1117	SpEd - Independent Evaluations	42,109	15,730	15,811	13,000	13,000	13,000	13,000	13,000									0	
1144	SpEd - Out of State Placements	50,429	59,942	74,681	53,000	53,000	53,000	0	0									0	
674	SpEd - Rockville Vo-Ag	0	0	0	0	0	0	0	0									0	
673	SpEd - Tuition	300,516	278,476	318,074	269,000	293,000	338,000	343,000	343,000									0	
670	SpEd - Gengras	0	0	0	0	0	0	0	0									0	
813	SpEd - CREC Hearing Program	29,758	26,000	15,059	8,200	15,000	15,000	15,000	15,000									0	
1180	SpEd Woodstock	0	0	0	0	0	0	0	0									0	
1142	SW - Consultant Fees	20,683	5,008	11,621	10,000	10,000	10,000	10,000	10,000									0	
1674	SpEd - Contracted Services		17,010	21,443		26,000	20,000	35,000	35,000									0	
	Tuition Special Education	595,462	609,233	628,794	555,952	612,752	651,752	693,200	694,700									1,500	0.22%
638	Enfield Adult Education	10,932	10,864	11,311	10,900	10,900	10,900	12,900	12,900									0	
	Adult Education	10,932	10,864	11,311	10,900	10,900	10,900	12,900	12,900									0	0.00%
1577	SW - Signing Interpreter	0	0	0	0	0	0	0	0									0	
1336	One Time Investment	0	0	0														0	
	Other	0	0	0	0	0	0	0	0									0	#DIV/0!
	TOTAL	19,352,663	19,327,140	19,802,802	19,354,979	19,334,317	19,827,174	20,357,880	20,719,664									361,784	1.78%

