

Regular Board of Education Meeting
Wednesday, October 20, 2021 7:00 PM
Town Hall Meeting Room* (*All attendees must wear face masks and maintain social distance.)

I. Administrative Reports

A. Chairman's Corner (5 min.)

Goals: Community Engagement: Enhance communication and build trusting relationships with all stakeholders.

Rationale: Ms. Sarah Thrall, Board Chair, will share opening remarks.

B. Superintendent's Announcements (5 min.)

Goals: Community Engagement: Enhance communication and build trusting relationships with all stakeholders.

Rationale: Dr. Jordan Grossman, Superintendent, will provide district updates.

C. Assistant Superintendent's Report (5 min.)

Goals: Community Engagement: Enhance communication and build trusting relationships with all stakeholders.

Rationale: Ms. Jennifer Parsons, Assistant Superintendent, will provide updates from the Assistant Superintendent's office.

D. Student Representative Reports (5 min.)

Rationale: Mr. Jacob Scotto and Ms. Tess Bajek, Student Representatives, will report on activities taking place at the high school.

E. Business Manager's Report (5 min.)

Attachments:

Sept 2021 Statement of Accounts

3

Rationale: Ms. Anna Robbins, Business Manager, will present the September statement of accounts.

F. Schools in the Spotlight (15 min.)

Attachments:

OnShape presentation for BOE

9

Rationale: Mr. David Pickhardt, Technology Teacher, along with 7th grade students, Emma Wiltshire and Ryan Coxon, will present Onshape which is the new 3D modeling and drafting software at Granby Memorial Middle School.

II. Public Comment (20 min.)

Rationale: Granby community engagement and attendance at BOE public meetings is welcomed. The Public Comment segment of the meeting agenda is set aside so the BOE may receive public comments. Procedurally, public remarks will be limited to about 5 minutes and citizens will be asked to identify themselves. Because the BOE is limited by the Freedom of Information Act to discussing only matters on the agenda, the BOE is not permitted to engage in a discussion of the comments presented.

III. Consent Agenda (5 min.)

A. Minutes

Rationale: The Board will approve/amend the minutes of the October 6, 2021 Board of Education meeting.

IV. Old Business

A. Approval of 2021-2025 Strategic Plan for Granby Public Schools

Attachments:

Strategic Plan Draft 10-20-21 38

Rationale: The Board will discuss and consider the approval of the 2021-2025 Strategic Plan for Granby Public Schools.

V. New Business

A. Granby Association of School Administrators (GASA) Agreement Ratification

Attachments:

GASAContractChanges2022-2025 (BOE) 50

Rationale: The Board will discuss and consider the ratification of the Granby Association of School Administrators' Agreement effective July 1, 2022 through June 30, 2025.

VI. Miscellaneous (20 min.)

A. Board Standing Committee Reports

1. Curriculum/Policy/Technology/Communication

Attachments:

Curriculum SC Minutes 10-6-21 51

2. Finance/Personnel/Facilities

Goals: Budget Development and Fiscal Management: Practice responsible budget development and management through transparency and maximize available financial resources through a balance of fiscal discipline and innovative educational investments., Student Achievement: Improve student achievement, academic performance and opportunity at all grade levels and for all ability levels and decrease achievement gaps on the path to college and career readiness., Community Engagement: Enhance communication and build trusting relationships with all stakeholders.

B. Other Board-Related Reports

1. CREC/CABE

Goals: Safety and Social Emotional Well-Being: Foster a safe and positive social emotional environment for everyone.

2. Granby Education Foundation

Goals: Embracing Diversity: Adopt and promote strong instructional, curricular and leadership practices that embrace and advance knowledge and acceptance of human diversity and that eliminate bias.

C. Calendar of Events

D. Board Member Announcements

E. Action Items

VII. Executive Session/Non-Meeting

Jordan E. Grossman, Ed.D.
Superintendent of Schools



Jennifer M. Parsons
Assistant Superintendent

Angela E. Ehrenwerth
Director of Pupil Personnel Services

Anna M. Robbins, SFO
Business Manager

To: Granby Board of Education
From: Anna Robbins, Business Manager
Date: October 20, 2021
Re: September 2021 Statement of Accounts FY22 Year-to-date

As of September 30, 2021, the BOE shows a positive forecast of \$119K. Special education expenditures are projected to be unfavorable \$32K and regular education expenditures are projected to be favorable \$150K. The driving factor for positive forecast in regular education is turnover in personnel. Although special education expenses are forecasted to be over-budget for the year, the change since the previous month is favorable. The favorable variance in personnel cost as well as out-of-district transportation has significantly reduced the overall over-budget condition.

At this time, the Quality & Diversity Fund balance is projected to be favorable \$148K. The balance from FY21 was positive and carried over to FY22. In addition, there were no expenses or revenue for summer school in FY22.

Revenues to the town are projected to be under-budget by \$6K. We will have more accurate information once the tuitions to other towns is calculated and billed. Excess cost funding from the state is projected to be slightly higher than budgeted which reflects the addition of expenses that exceed the per student stop loss. Projections for rental fees and pay-for-participation fees are uncertain at this time and reflects no rental fee income for the foreseeable future. At this time, the athletic program is expected to proceed as normal.

Granby Board of Education
FY 2021-2022
Statement of Accounts
for the period ended
September 30, 2021

| Description | Budget | Expended | Encumbered | Expended & Encumbered | Budget Balance | % Enc/Exp | September Forecast | Results Compared to Prior Month Forecast |
|---|-------------------|------------------|-------------------|--------------------------|------------------|---------------|-----------------------|--|
| Certified Salaries: | | | | | | | | |
| Administration | 1,751,243 | 470,719 | 1,277,667 | 1,748,386 | 2,856 | 99.84% | 2,856 | 0 |
| Regular Education | 10,955,845 | 1,257,901 | 9,371,661 | 10,629,562 | 326,283 | 97.02% | 182,373 | 18,012 |
| Special Education | 1,939,332 | 270,321 | 1,523,292 | 1,793,613 | 145,719 | 92.49% | 64,100 | 45,880 |
| Total | 14,646,419 | 1,998,941 | 12,172,620 | 14,171,561 | 474,859 | 96.76% | 249,329 | 63,892 |
| Substitute/Tutor/Support Salaries | | | | | | | | |
| Substitutes | 8,000 | 1,514 | 0 | 1,514 | 6,486 | 18.93% | 0 | 0 |
| Sped Support (Speech, O.T. & P.T.) | 460,454 | 64,282 | 393,124 | 457,406 | 3,048 | 99.34% | 812 | (383) |
| Tech Support | 250,682 | 64,022 | 186,762 | 250,784 | (102) | 100.04% | (102) | 0 |
| Tutors - Regular Education | 38,147 | 1,605 | 19,862 | 21,467 | 16,680 | 56.27% | 0 | 0 |
| Tutors - Special Education | 29,480 | 12,046 | 0 | 12,046 | 17,434 | 40.86% | 6,536 | 0 |
| Total | 786,763 | 143,470 | 599,748 | 743,218 | 43,545 | 94.47% | 7,246 | (383) |
| Teaching Assistant Salaries: | | | | | | | | |
| Regular Education TA | 310,340 | 32,559 | 323,723 | 356,283 | (45,943) | 114.80% | (45,500) | (45,500) |
| Special Education TA | 1,185,080 | 41,969 | 1,093,662 | 1,135,631 | 49,449 | 95.83% | 41,125 | 41,125 |
| Total | 1,495,420 | 74,528 | 1,417,385 | 1,491,913 | 3,506 | 99.77% | (4,374) | (4,374) |
| School Secretaries' Salaries | 666,332 | 121,431 | 538,624 | 660,055 | 6,277 | 99.06% | (963) | (2,491) |
| Central Office Salaries | 575,725 | 124,793 | 444,178 | 568,972 | 6,753 | 98.83% | 4,466 | 4,466 |
| Custodial & Maintenance Salaries | 1,341,989 | 294,062 | 956,420 | 1,250,482 | 91,507 | 93.18% | 8,241 | (292) |
| Total Salaries | 19,512,648 | 2,757,226 | 16,128,975 | 18,886,201 | 626,447 | 96.79% | 263,944 | 60,817 |
| Employee Benefits | 5,646,727 | 1,084,090 | 3,865,460 | 4,949,550 | 697,177 | 87.65% | 0 | 0 |
| Total Salaries & Employee Benefits | 25,159,375 | 3,841,316 | 19,994,435 | 23,835,751 | 1,323,623 | 94.74% | 263,944 | 60,817 |

Granby Board of Education
FY 2021-2022
Statement of Accounts
for the period ended
September 30, 2021

| Description | Budget | Expended | Encumbered | Expended & Encumbered | Budget Balance | % Enc/Exp | September Forecast | Results Compared to Prior Month Forecast |
|--------------------------------------|------------------|----------------|------------------|--------------------------|----------------|---------------|-----------------------|--|
| Purchased Services: | | | | | | | | |
| Instructional Purchased Service | 563,326 | 34,165 | 362,765 | 396,929 | 166,397 | 70.46% | 0 | 0 |
| Administration Purchased Service | 462,937 | 51,790 | 371,737 | 423,526 | 39,411 | 91.49% | 0 | 0 |
| Maintenance Purchased Service | 101,483 | 18,936 | 22,604 | 41,540 | 59,943 | 40.93% | 0 | 0 |
| Total | 1,127,746 | 104,890 | 757,106 | 861,996 | 265,750 | 76.44% | 0 | 0 |
| Legal Services | 55,000 | 1,403 | 53,597 | 55,000 | 0 | 100.00% | 0 | 0 |
| Repairs & Maintenance: | | | | | | | | |
| Instructional Repairs & Maintenance | 74,599 | 29,332 | 11,532 | 40,864 | 33,735 | 54.78% | 0 | 0 |
| Administration Repairs & Maintenance | 8,500 | 0 | 0 | 0 | 8,500 | 0.00% | 0 | 0 |
| Maintenance Repairs & Maintenance | 434,698 | 107,782 | 162,714 | 270,496 | 164,202 | 62.23% | 0 | 0 |
| Total | 517,797 | 137,115 | 174,246 | 311,360 | 206,437 | 60.13% | 0 | 0 |
| Transportation: | | | | | | | | |
| Transportation Regular Education | 954,914 | 10,272 | 767,793 | 778,065 | 176,849 | 81.48% | 0 | 0 |
| Transportation Special Education | 708,654 | 2,545 | 512,329 | 514,874 | 193,780 | 72.66% | 166,595 | 5,122 |
| Transportation Vocational Tech | 92,862 | 0 | 88,960 | 88,960 | 3,902 | 95.80% | 3,902 | 3,902 |
| Total | 1,756,430 | 12,817 | 1,369,081 | 1,381,898 | 374,532 | 78.68% | 170,497 | 9,024 |
| Insurance Property & Liability | 102,700 | 65,434 | 42,124 | 107,558 | (4,858) | 104.73% | (5,000) | (5,000) |
| Communications | 91,881 | 17,589 | 54,921 | 72,510 | 19,371 | 78.92% | 0 | 0 |
| Tuition: | | | | | | | | |
| Tuition Special Education | 1,747,882 | 223,439 | 1,390,971 | 1,614,410 | 133,471 | 92.36% | (310,800) | 37,803 |
| Tuition Adult Education | 11,967 | 0 | 0 | 0 | 11,967 | 0.00% | 0 | 0 |
| Total | 1,759,849 | 223,439 | 1,390,971 | 1,614,410 | 145,438 | 91.74% | (310,800) | 37,803 |
| Conference & Travel Expense | 77,694 | 5,167 | 4,574 | 9,741 | 67,953 | 12.54% | 0 | 0 |

Granby Board of Education
FY 2021-2022
Statement of Accounts
for the period ended
September 30, 2021

| Description | Budget | Expended | Encumbered | Expended & Encumbered | Budget Balance | % Enc/Exp | September Forecast | Results Compared to Prior Month Forecast |
|------------------------------------|-------------------|--------------------------|-------------------------------------|--------------------------|------------------|---------------|-----------------------|--|
| General Supplies: | | | | | | | | |
| General Supplies Regular Education | 317,970 | 93,526 | 72,387 | 165,912 | 152,058 | 52.18% | 0 | 0 |
| General Supplies Special Education | 27,316 | 7,525 | 8,068 | 15,593 | 11,723 | 57.09% | 0 | 0 |
| General Supplies Administration | 79,976 | 18,070 | 19,315 | 37,385 | 42,591 | 46.75% | 0 | 0 |
| General Supplies Maintenance | 141,372 | 20,704 | 69,503 | 90,207 | 51,165 | 63.81% | 0 | 0 |
| Total | 566,634 | 139,825 | 169,273 | 309,098 | 257,536 | 54.55% | 0 | 0 |
| Electricity | 420,812 | 61,115 | 0 | 61,115 | 359,697 | 14.52% | 0 | 0 |
| Fuel/Natural Gas | 169,352 | 63,214 | 76,056 | 139,270 | 30,082 | 82.24% | 0 | 0 |
| Textbooks/Workbooks | 124,528 | 36,139 | 17,502 | 53,641 | 70,887 | 43.08% | 0 | 0 |
| Library/Media Center | 62,237 | 11,422 | 17,625 | 29,047 | 33,190 | 46.67% | 0 | 0 |
| Software | 322,868 | 217,466 | 32,963 | 250,429 | 72,439 | 77.56% | 0 | 0 |
| Dues & Fees | 50,346 | 35,959 | 1,127 | 37,086 | 13,260 | 73.66% | 0 | 0 |
| Replacement Equipment: | | | | | | | | |
| Replacement Equipment | 0 | 0 | 0 | 0 | 0 | 0.00% | 0 | 0 |
| Replacement Equip Admin | 6,000 | 0 | 0 | 0 | 6,000 | 0.00% | 0 | 0 |
| Replacement Equip Maintenance | 2,500 | 0 | 632 | 632 | 1,869 | 25.26% | 0 | 0 |
| Total | 8,500 | 0 | 632 | 632 | 7,869 | 7.43% | 0 | 0 |
| New Equip Instr MS | 0 | 0 | 555 | 555 | (555) | 0.00% | 0 | 0 |
| Student Activities | 809,760 | 47,119 | 367,778 | 414,897 | 394,863 | 51.24% | 0 | 0 |
| Total General Fund | 33,183,507 | 5,021,429 | 24,524,565 | 29,545,994 | 3,637,513 | 89.04% | 118,641 | 102,644 |
| | SPED | 6,186,807 | | | | | (31,632) | |
| | GEN ED | 26,996,700 | | | | | 150,273 | |
| Quality & Diversity | Budget | Sept Forecast | Better/Worse Than Budget | | | | | |
| Opening Balance | 210,550 | 352,101 | 141,551 | | | | | |
| Expenses | 1,056,942 | 1,009,028 | 47,914 | | | | | |
| Revenue | 875,253 | 833,450 | (41,803) | | | | | |
| Ending Balance | 28,861 | 176,523 | 147,662 | | | | | |

**Granby Board of Education
 FY 2021-2022
 Statement of Accounts
 for the period ending
 September 27, 2021
 For Selected Special Education Accounts**

| II. Expenditures | FY21-22 Budget | Expended | Encumbered | Expended & Encumbered | Balance | Full Year Forecast September 2021 | Compared to prior month Forecast |
|--|------------------|----------------|------------------|--------------------------|----------------|--------------------------------------|--|
| Legal Expense | 27,500 | 0 | 27,500 | 27,500 | 0 | 0 | 0 |
| Special Education Certified Staff | 1,939,332 | 270,321 | 1,523,292 | 1,793,613 | 145,719 | 64,100 | 81,619 |
| Teacher Assistants | 1,185,080 | 41,969 | 1,093,662 | 1,135,631 | 49,449 | 41,125 | 8,324 |
| Special Education Tutors | 29,480 | 12,046 | 0 | 12,046 | 17,434 | 6,536 | 10,899 |
| Evaluation, Therapy & Contracted Services | 88,425 | 5,320 | 46,858 | 52,178 | 36,247 | 0 | 36,247 |
| Sped Support (Speech, O.T., & P.T.) | 460,454 | 64,282 | 393,124 | 457,406 | 3,048 | 812 | 2,236 |
| Special Ed Transportation | 708,654 | 2,545 | 512,329 | 514,874 | 193,780 | 166,595 | 27,185 |
| Out of District Tuition | 1,747,882 | 223,439 | 1,390,971 | 1,614,410 | 133,471 | (310,800) | 444,271 |
| Total Selected Special Education Accounts | 6,186,807 | 619,923 | 4,987,735 | 5,607,658 | 579,149 | (31,632) | 610,781 |

Granby Board of Education
FY 2021-2022
Statement of Accounts
for the period ending September 30, 2021

| I. Revenue | FY 2021-2022 Budget | Currently Anticipated | Received To Date | Full Year Forecast August 2021 |
|--------------------------------------|--------------------------------|----------------------------------|-----------------------------|---|
| Reg. Tuition from other Towns | 614,448 | 614,448 | 0 | 0 |
| SPED Tuition from other Towns | 456,273 | 456,273 | 0 | 0 |
| SDE Excess Cost Reimbursement | 491,779 | 500,720 | 0 | 8,941 |
| Rental Fees | 14,745 | 0 | 0 | (14,745) |
| Pay for Participation | 53,966 | 53,966 | 7,006 | 0 |
| Sub Total | <u>1,631,211</u> | <u>1,625,407</u> | <u>7,006</u> | <u>(5,804)</u> |

onshape

A path of evolution in design and modeling in
Granby Public Schools.



Sign in to Granby Public Schools

granbyct.onshape.com

**Everything that is built
starts as a design.**

**A little history of technical
design in
Granby Public Schools.**

Just like industry it all started
on the drawing boards.

T-Square

Triangles

Pencil

Paper

Tape

Lots of erasers!

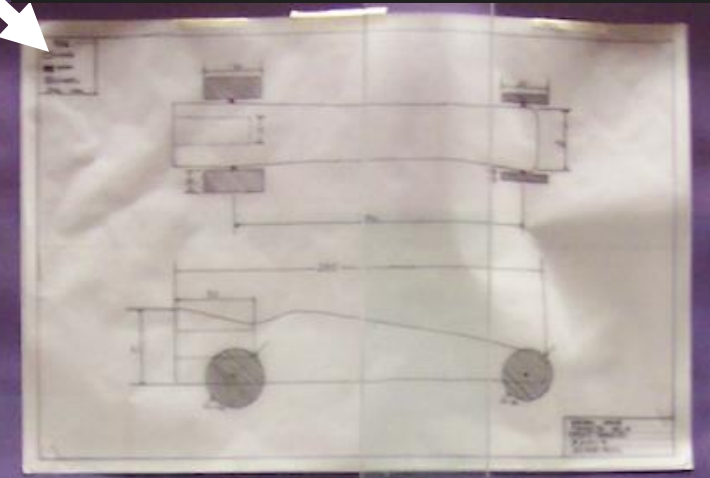

**Finally as time
went on and
drafting
software got
more
affordable and
powerful
computers
got cheaper, it
moved from
paper to
computer.**



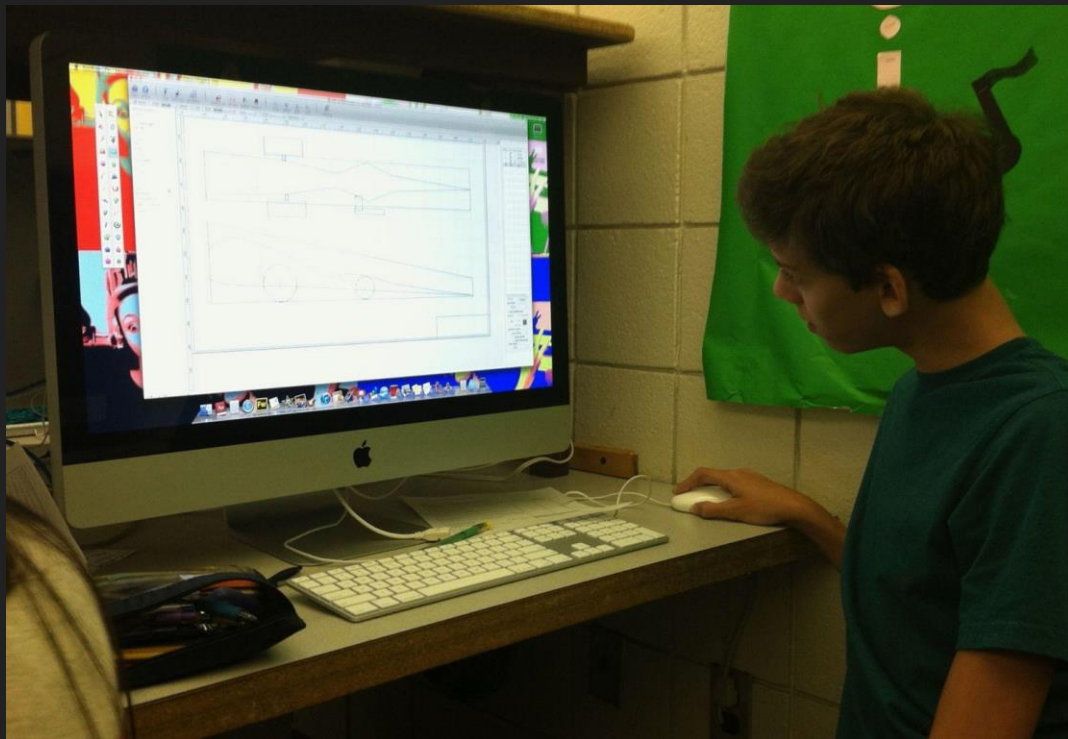

There were lots of stops in software over 26 years.

AutoCAD Lite

AutoCAD

MiniCAD

EzCAD

Claris Draw

Apple Draw

EazyDraw

**As the times
change,
Granby
schools
have always
changed
with the
times.**

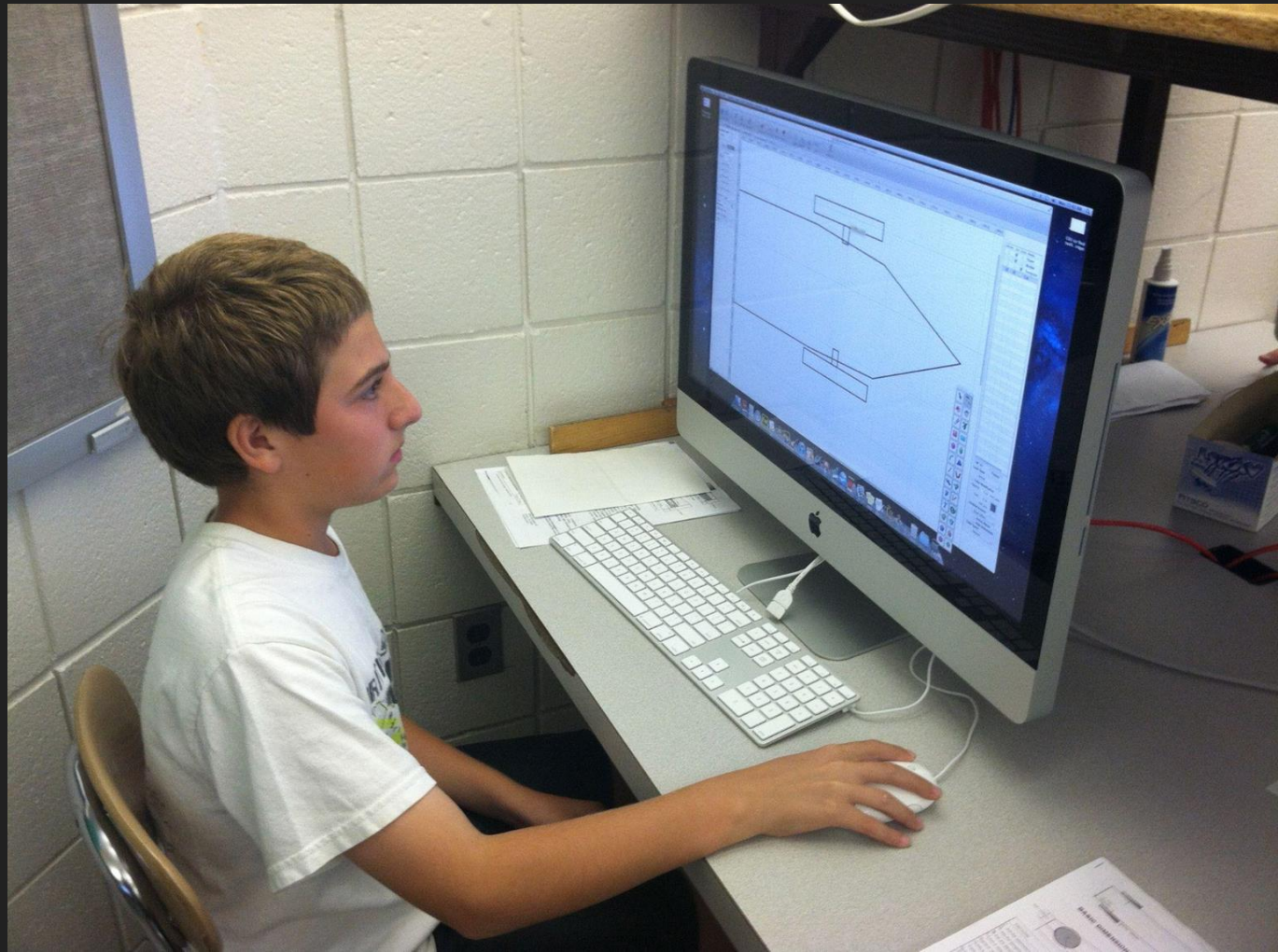

**But every once
in a while...**

**There is a change that
changes everything!**

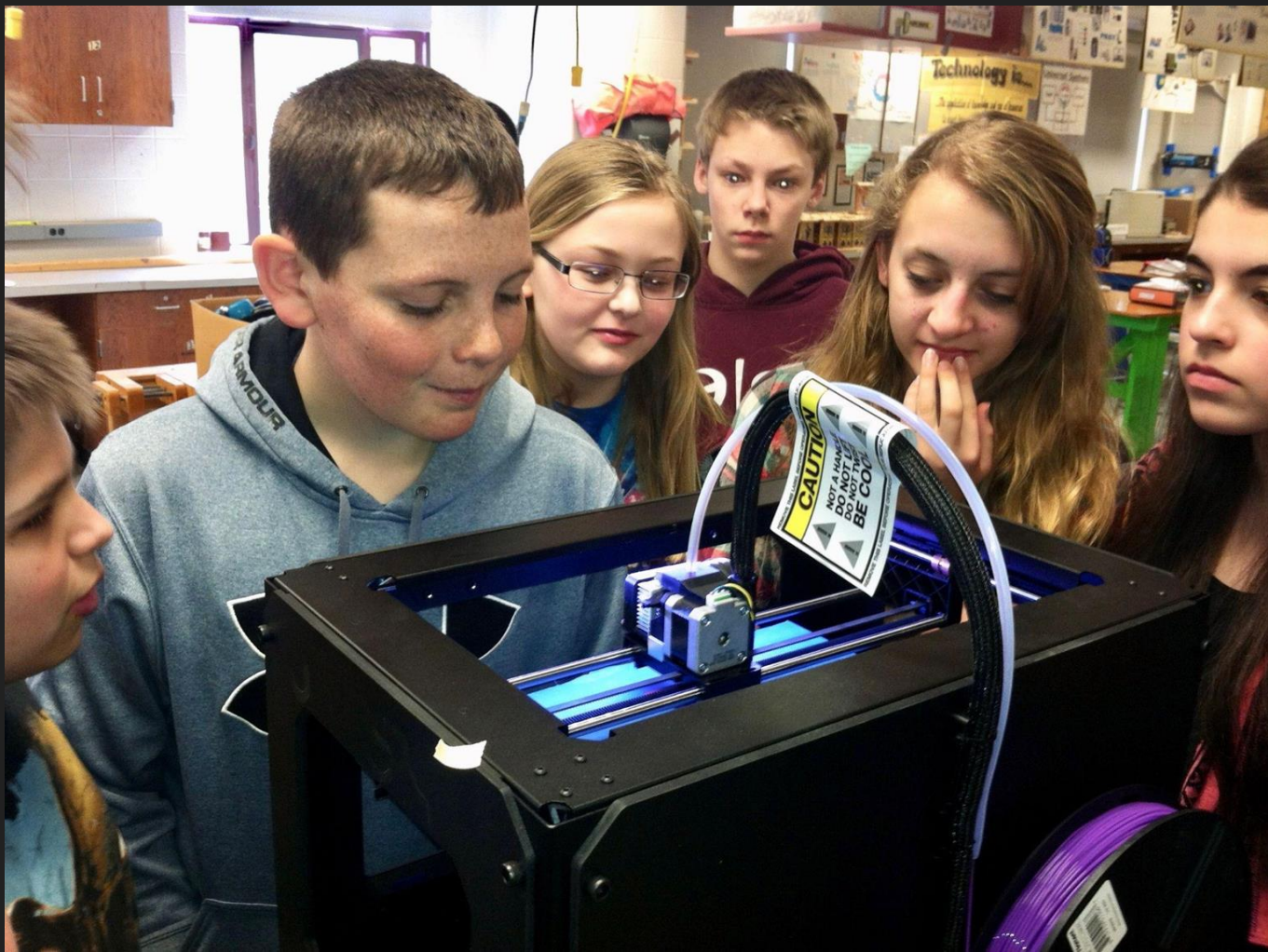

3D Printing and 3d Modeling

*Forever
changes our
thinking in
Granby
Technology
Education!*

**March 14
2014**

3d Modeling becomes a part of what we teach in Granby.



TinkerCAD



SolidWorks



onshape

6th



TinkerCAD



7th, 8th

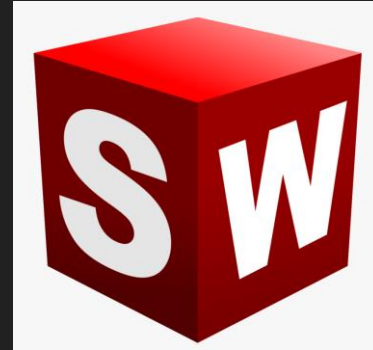

SolidWorks

Why another change?

***The world changed on
us and education
went online.***



A little history of onshape.

- **Created by the same engineers that created SolidWorks.**
- **Design interface and concepts are same.**
- **But completely cloud based, so it can be accessed from anywhere.**
- **Finally able to be used in schools.**

No longer is the student design learning limited to our labs.



2D Design

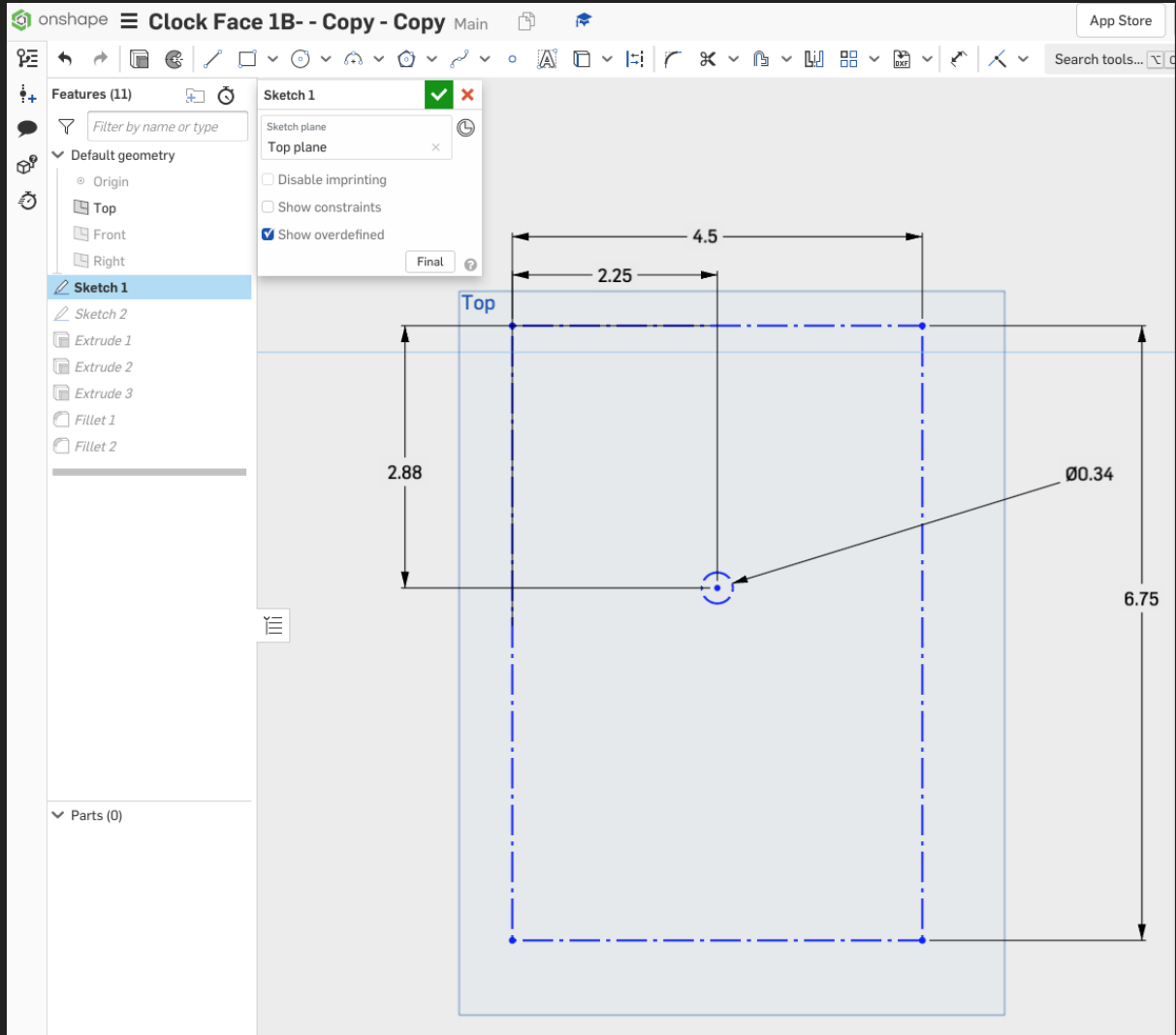

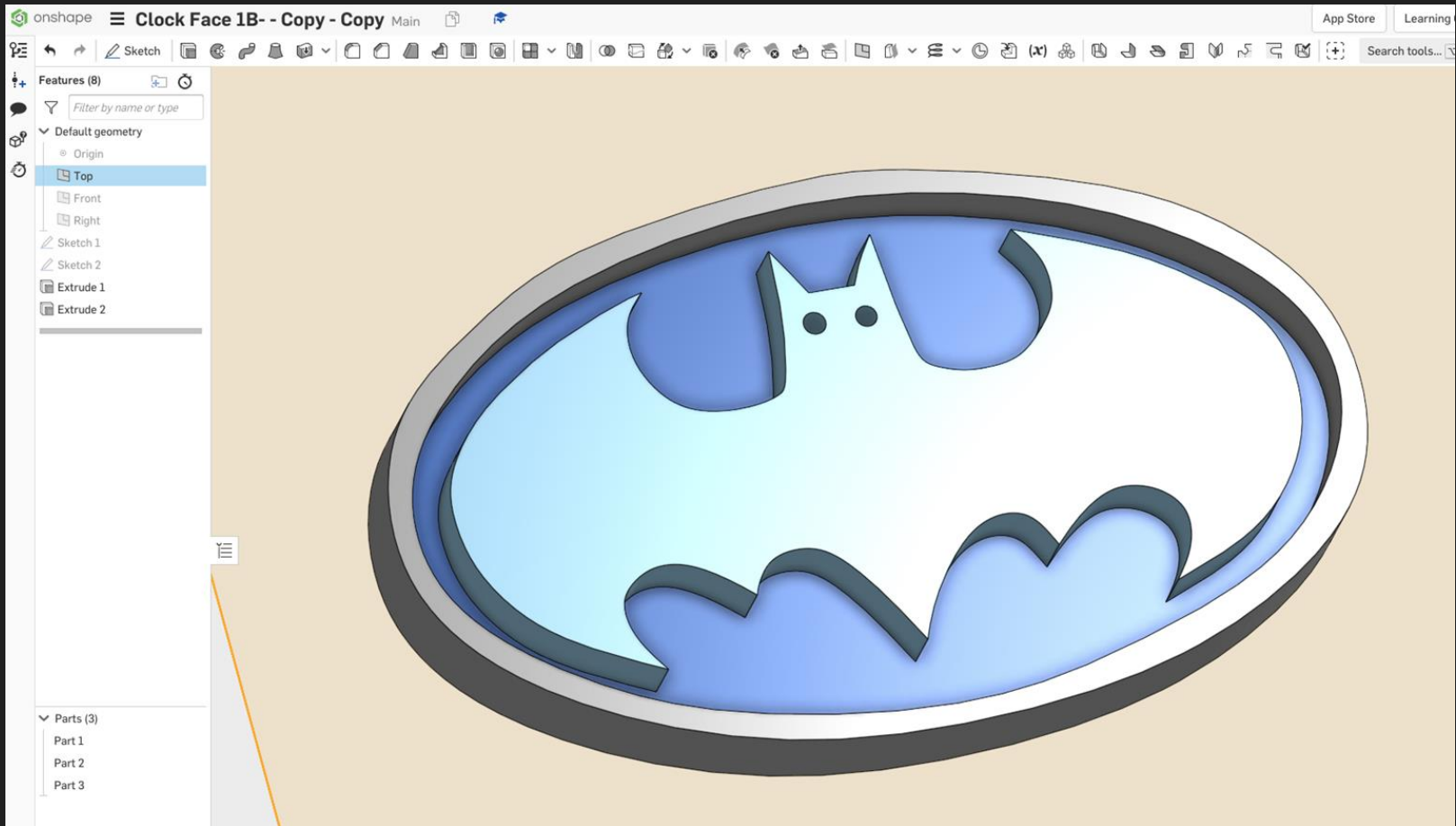

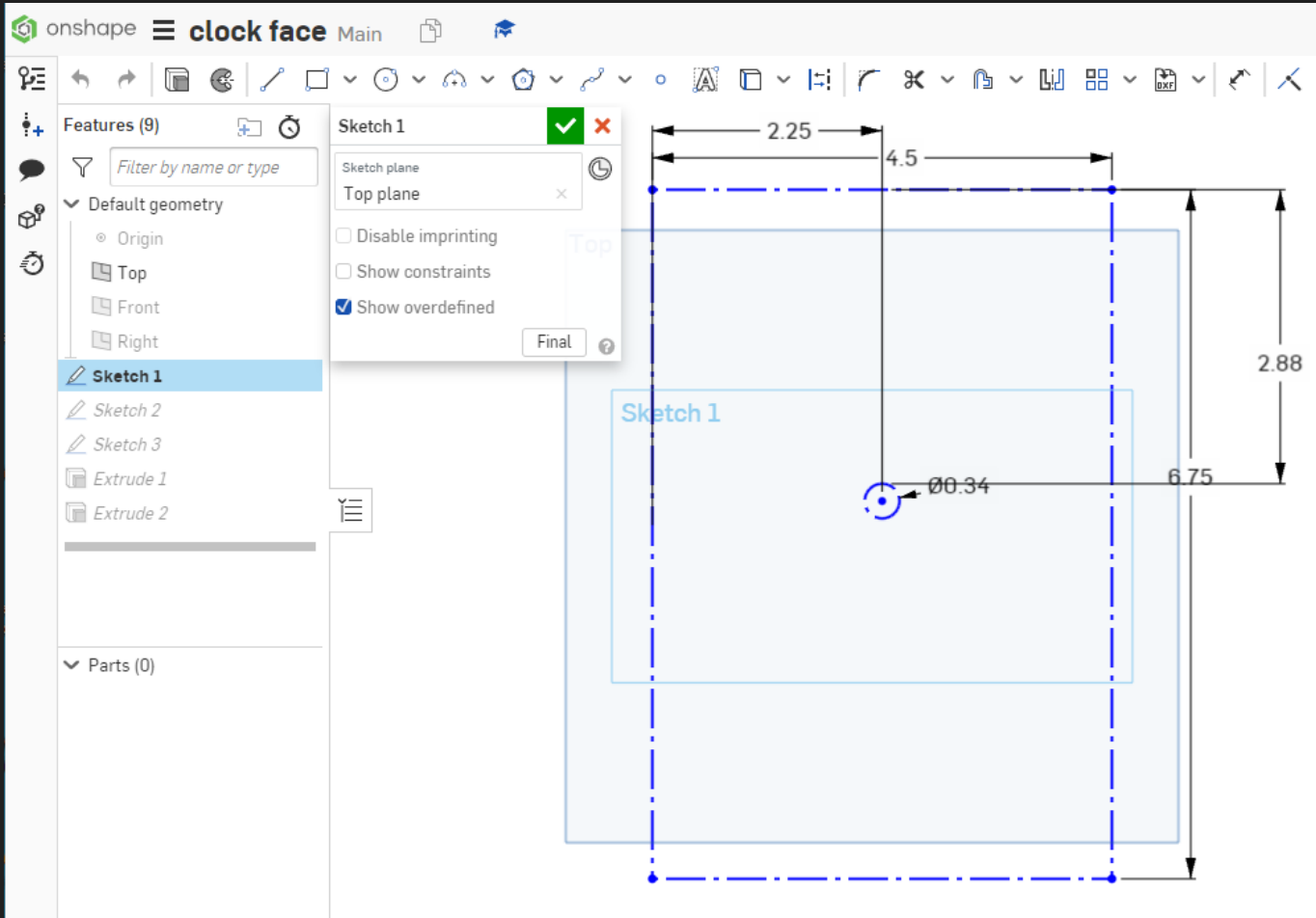

Emma Wiltshire

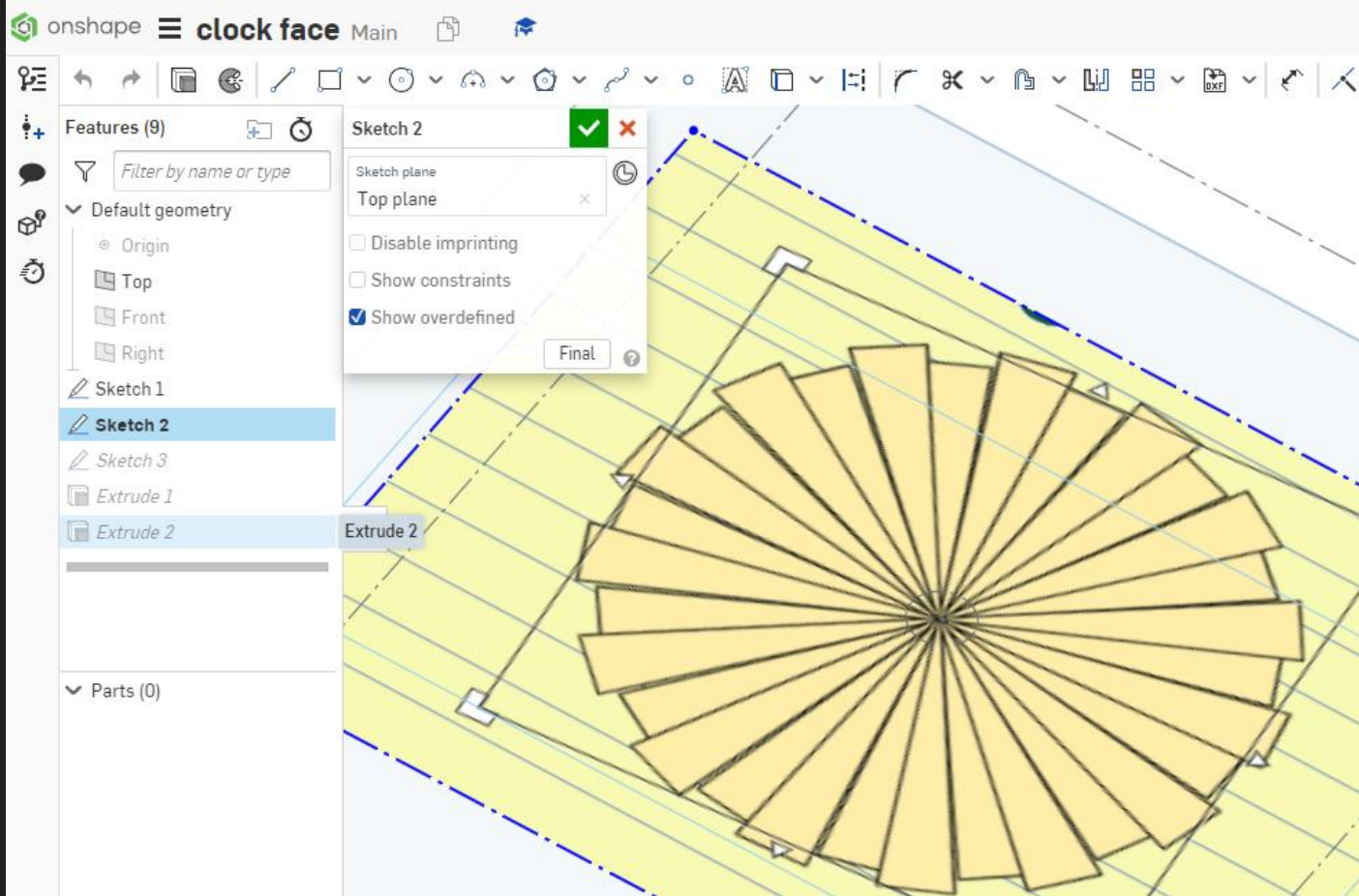

Emma Wiltshire

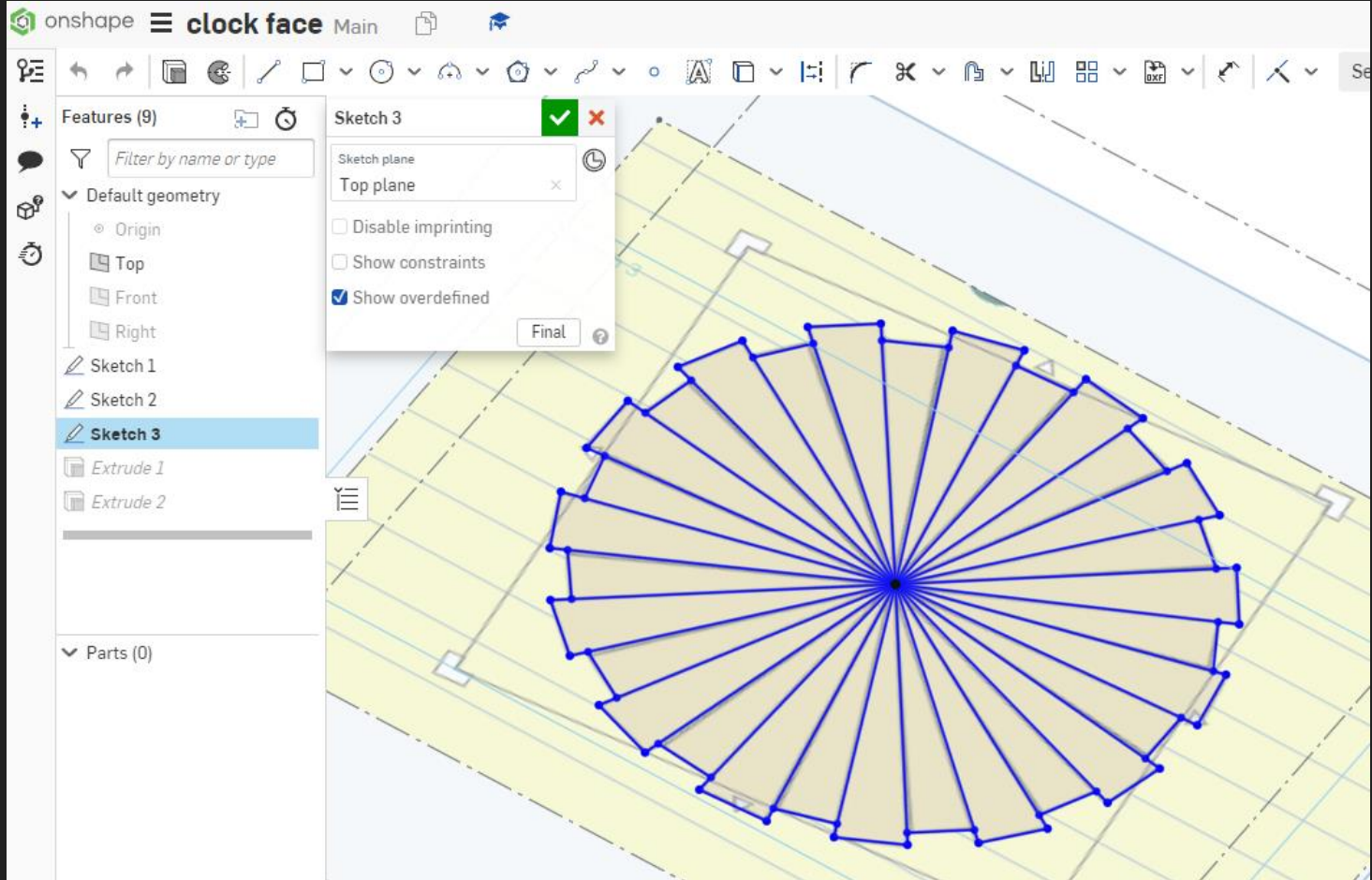

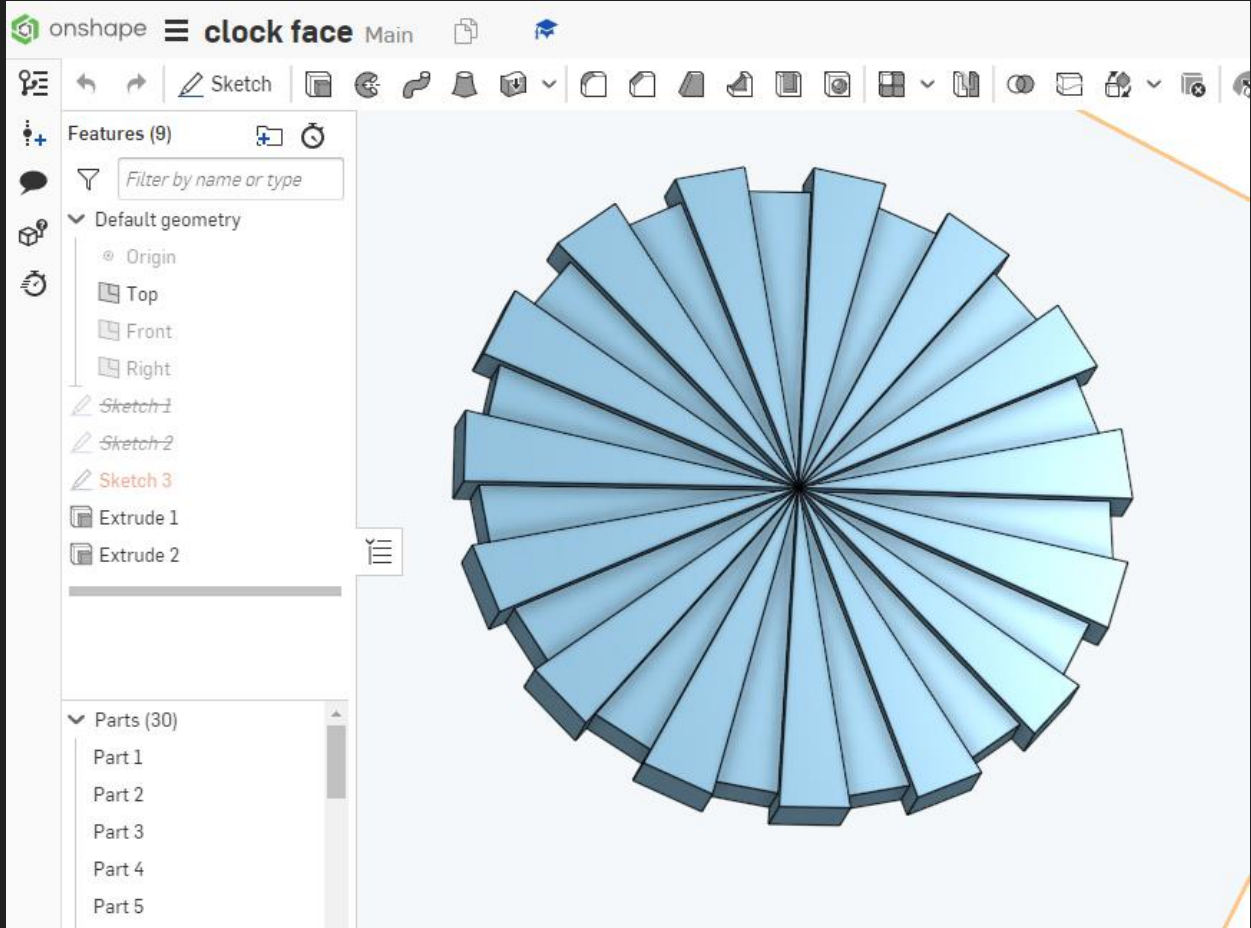

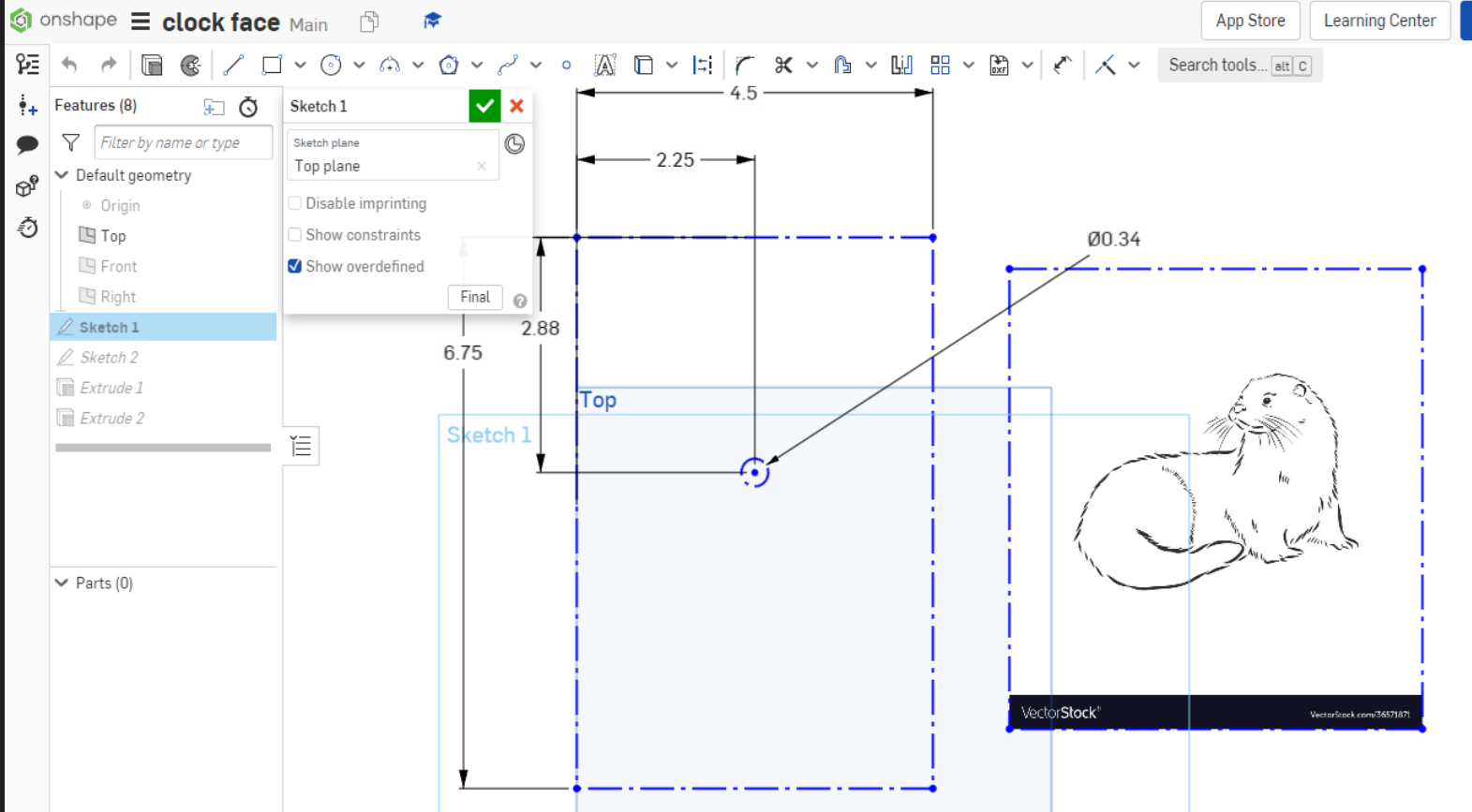



onshape **clock face** Main

Features (8)

- Default geometry
 - Origin
 - Top
 - Front
 - Right
- Sketch 1
- Sketch 2**
- Extrude 1
- Extrude 2

Parts (0)

Sketch 2

- Sketch plane: Top plane
- Disable imprinting
- Show constraints
- Show overdefined

Final

Ryan Coxon

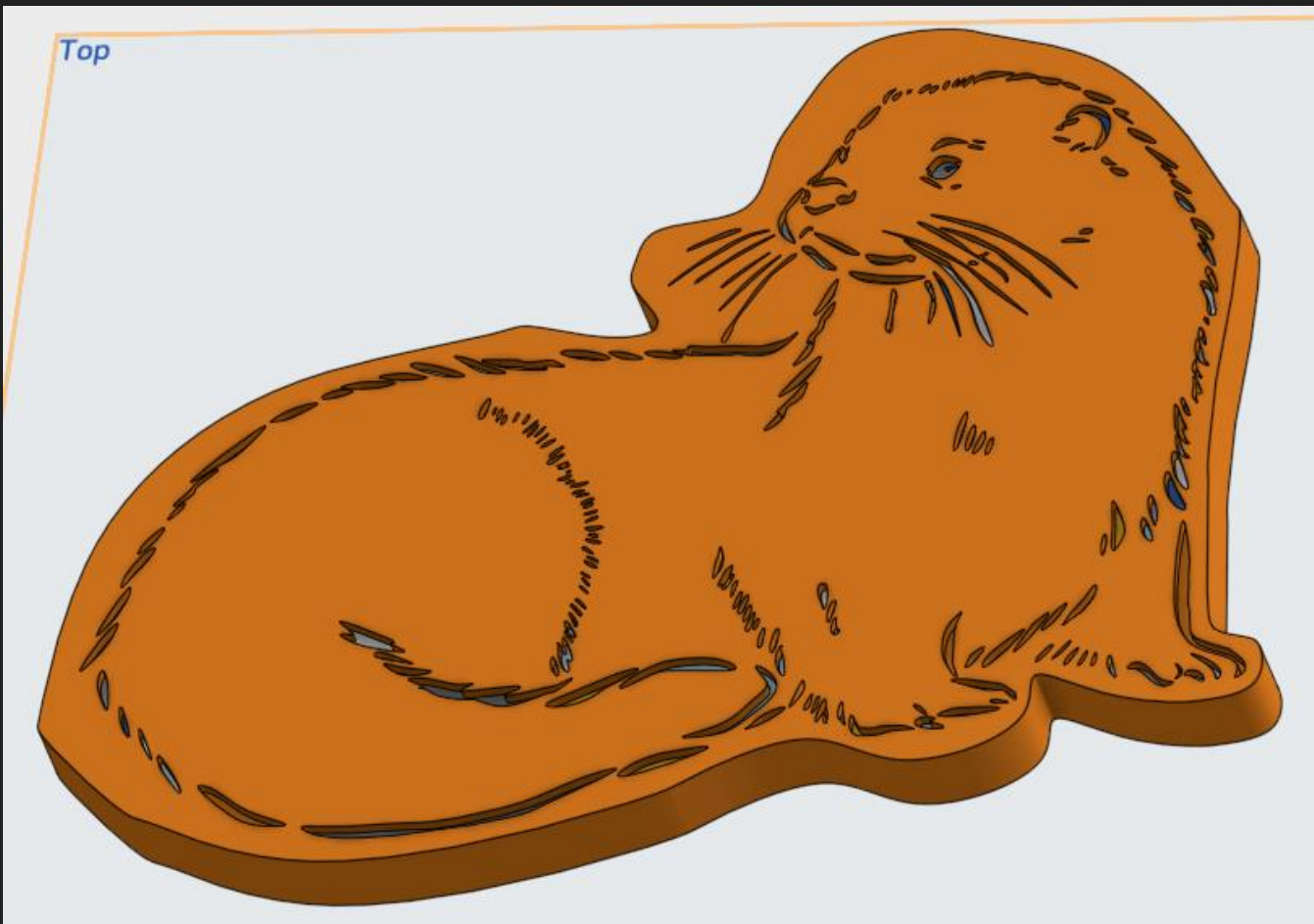

Ryan Coxon

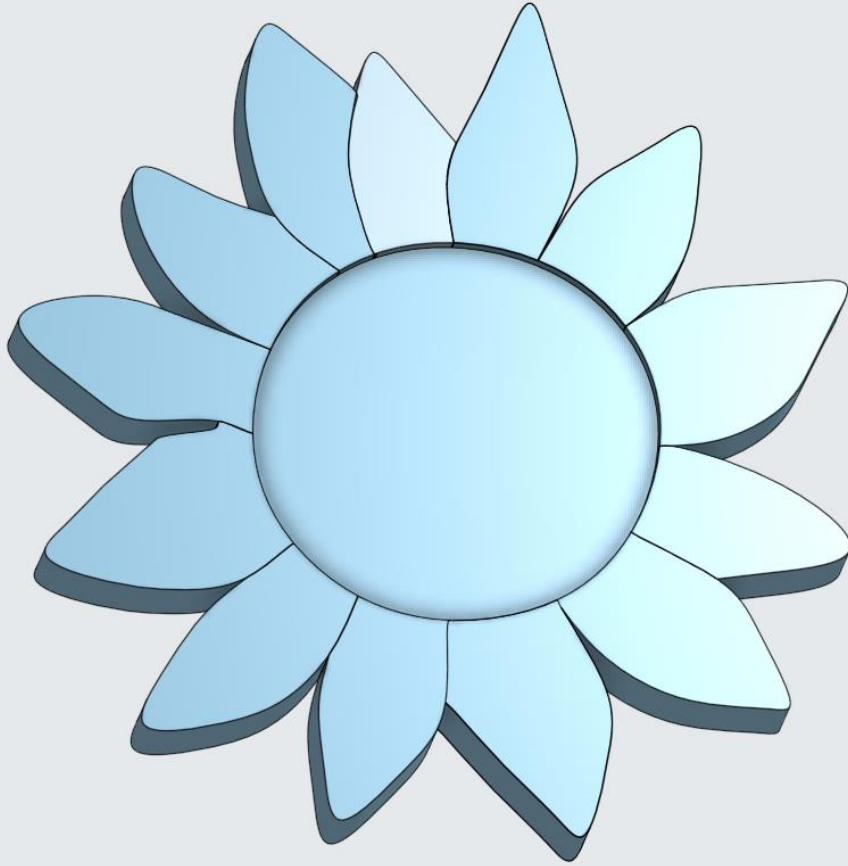

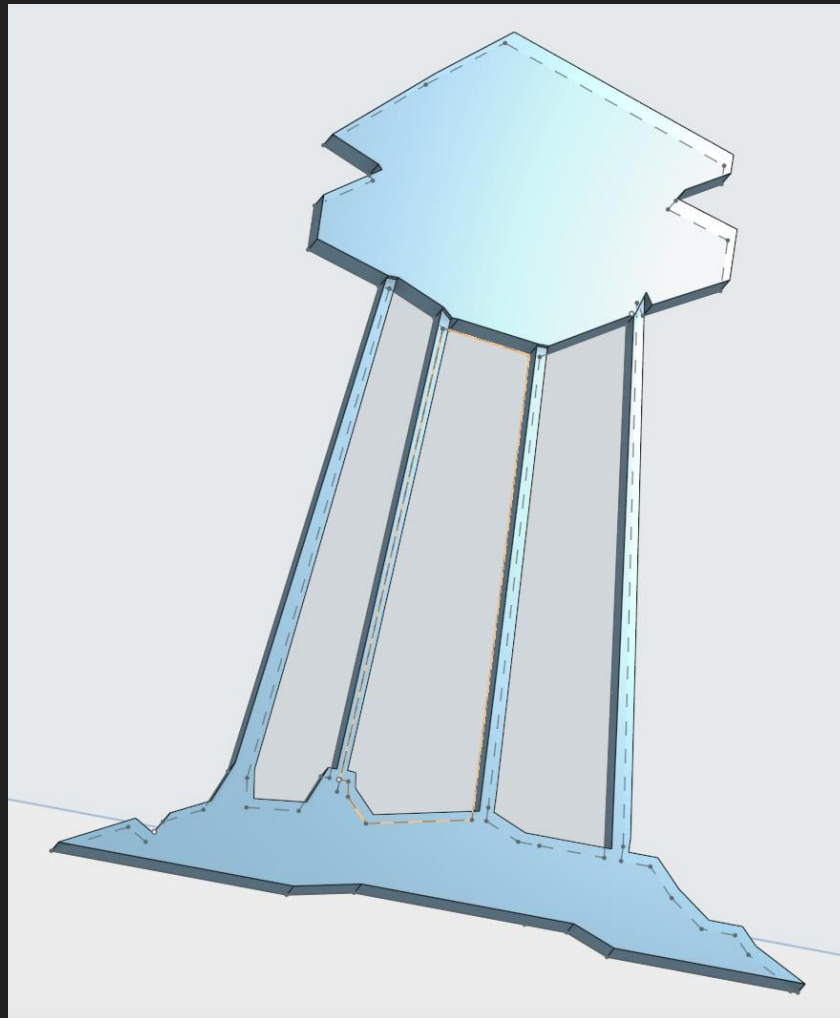

Colin Samalus

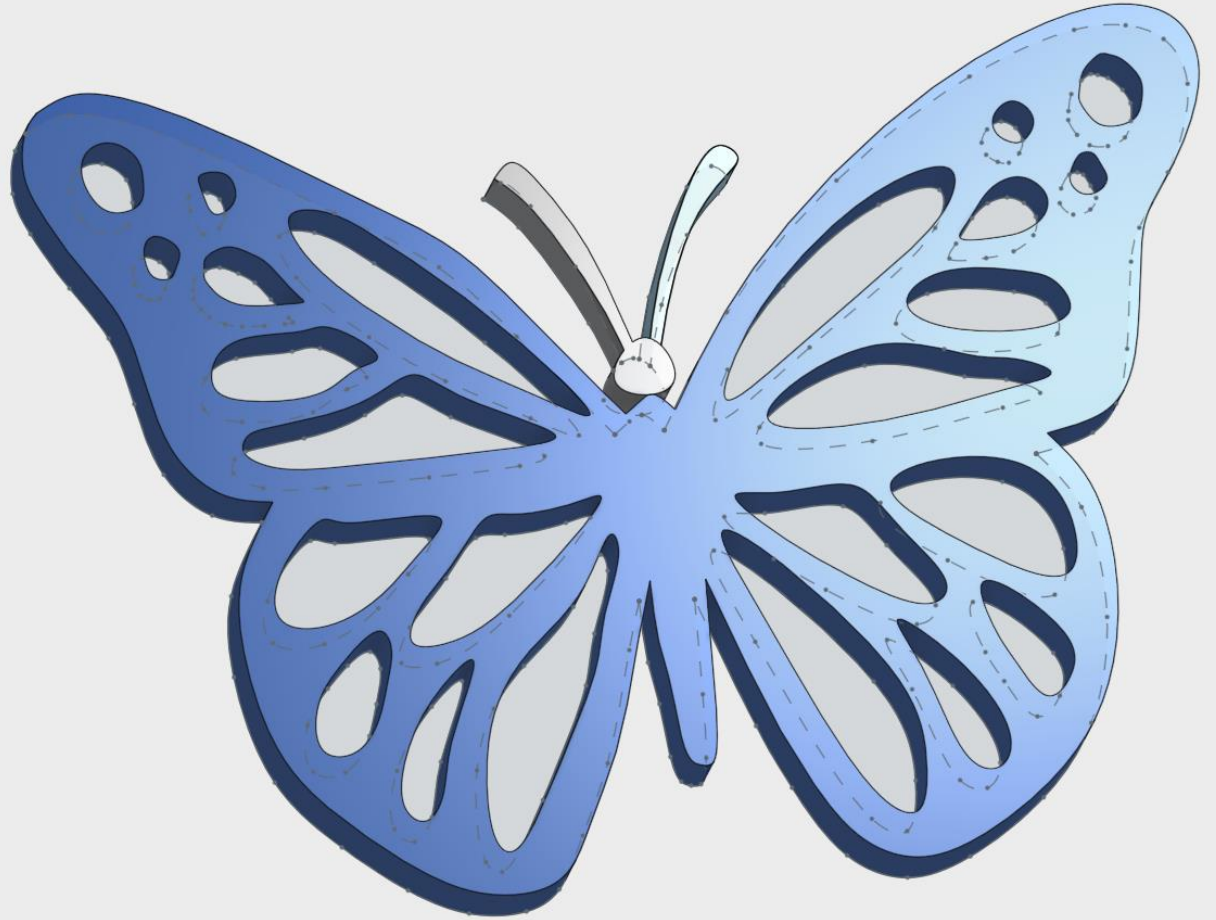

Questions I would have as a BOE member...

- **It is in the cloud - is it safe for kids to use?**
 - *Yes - OnShape operates in our own Granby OnShape domain. It is CT state department of Ed approved.*
- **Are these skills relevant and can they lead to a career?**
 - *Yes - Onshape has free online training and minimal fee certification programs. Students can actually move on in their own learning beyond class.*
 - *OnShape was developed by same engineers that developed SolidWorks, so skills are easily transferable.*
- **Are you preparing students for college life?**
 - *UCONN, RIT, and MIT have made or are making the switch.*

Questions I would have...

- **Will this continue into high school?**
 - *Yes, students will keep their onshape accounts as they move through Granby. If all goes as planned, this will be used as the core design package for Tech Ed courses at the high school.*
- **Can students use this at home?**
 - *It will run on their chromebooks, although screen size is limiting. But with a mouse and connected monitor students are already starting to use it at home.*
- **Can students collaborate with each other?**
 - *Engineers and designers are using onshape around the world to engineer just about anything you can think of.*

Further questions???

*As always, thank you for
your continued support
and a wonderful 26 years
so far!*

*Also special thank you to
GPS Tech Department!*



Granby Public Schools

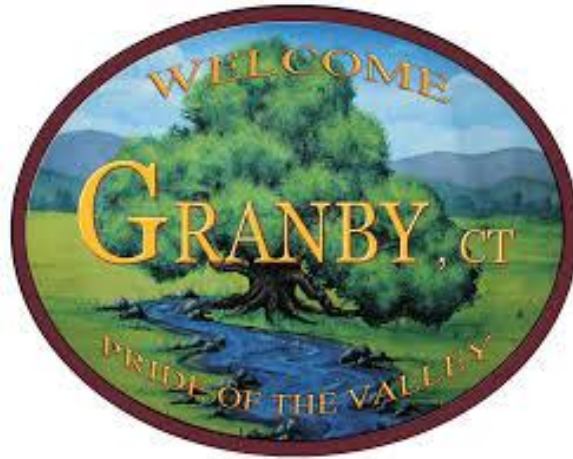

MOVING FORWARD TOGETHER STRATEGIC PLAN

2021-2025

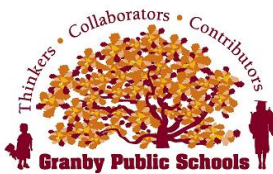



TABLE OF CONTENTS

| | |
|---|----|
| Message from the Board of Education | 1 |
| Core Values | 2 |
| Vision of a Graduate | 3 |
| Our Schools..... | 4 |
| Goal #1: Student Learning and Achievement..... | 5 |
| Goal #2: Community Development..... | 6 |
| Goal #3: Safety and Social Emotional Well-Being..... | 7 |
| Goal #4: Budget Development and Fiscal Management | 8 |
| Goal #5: Embracing Diversity..... | 9 |
| Goal #6: Professional Learning..... | 10 |



MESSAGE FROM THE BOARD OF EDUCATION

Dear Granby Community,

Following is 2021-2025 Strategic Plan for the Granby Public Schools. The Granby Board of Education would like to thank the Granby Public Schools Administration, community leadership, and other stakeholders for contributing to the development of this plan. Based on the adopted core values of the Board of Education, six goal areas are identified that will move our Granby Public Schools forward together. We look forward to working with the community as we implement this plan that embraces success for all of Granby's students.

Board of Education/Superintendent of Schools:



Sarah Thrall
Board Chairman



Mark Fiorentino
Vice Chairman



Rosemarie Weber
Secretary



Jenny Emery
Board Member



Melissa Migliaccio
Board Member



David Peling
Board Member

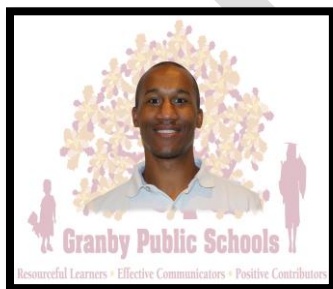

Brandon Webster
Board Member



Jordan E. Grossman, Ed.D.
Superintendent of Schools



CORE VALUES

The Board of Education's core values are the non-negotiable principles, shared beliefs and collective commitments that must be demonstrated by the Board of Education and district staff in order to advance the district vision and mission.

SUCCESS FOR ALL STUDENTS

WE BELIEVE the success of every student matters; outcomes should not be predictable by race, ethnicity, or socioeconomic status; and, equity demands the elimination of all achievement gaps and meeting the needs of students of all abilities and backgrounds.

SAFE ENVIRONMENT

WE BELIEVE providing a safe, secure and personalized learning environment is essential for students' physical, emotional and intellectual development.

CONTINUOUS IMPROVEMENT

WE BELIEVE in a commitment to continuous improvement through holding our practice to the highest standards of performance, effectiveness and efficiency.

ACCOUNTABILITY

WE BELIEVE accountability to the community for performance and results matters and that it is a reciprocal process requiring the provision of resources and support for staff to meet the expectations. Being accountable and reliable in our actions and commitments demonstrates responsibility, helps evaluate our effectiveness and informs practice.

DIVERSITY

WE BELIEVE in inclusiveness, that each individual's differences and contributions are valued and the diversity of cultures, abilities and backgrounds is an asset to the district.

ETHICAL BEHAVIOR

WE BELIEVE each individual's contributions add value to our learning community; fair treatment, honesty, openness, and integrity are essential.

ECONOMIC VALUE

WE BELIEVE in the wise stewardship and investment of funds and resources and in the realization of a high return on investment from the use of taxpayer funds.

VISION OF A GRADUATE

GRANBY PUBLIC SCHOOLS

Vision of a Graduate

All Granby Public Schools students will become resourceful learners and effective communicators who positively contribute at the local, national and global levels.

| | |
|--------------------------------|---|
| Resourceful Learners | <ul style="list-style-type: none">❖ Ask questions and identify problems or challenges❖ Identify strategies and methods for personal success❖ Explore and connect areas of interest❖ Set goals and persist in achieving these goals❖ Gather and evaluate a variety of sources and perspectives❖ Synthesize information and create solutions❖ Solve complex problems by applying approaches from multiple disciplines |
| Effective Communicators | <ul style="list-style-type: none">❖ Listen closely and respectfully participate in discourse❖ Value diverse voices and viewpoints❖ Prepare a message for an identified purpose and audience❖ Express ideas clearly in a variety of ways❖ Support arguments with evidence❖ Adapt and adjust thinking based on feedback and new learning❖ Use tools and technology flexibly and strategically |
| Positive Contributors | <ul style="list-style-type: none">❖ Develop meaningful connections with others❖ Collaborate for a common goal❖ Exhibit compassion and empathy❖ Make healthy and responsible decisions❖ Use personal talents and knowledge to contribute to society❖ Demonstrate civic responsibility❖ Understand that actions have impact on the local community, the country and our global society |

Adopted by the Granby Board of Education September 1, 2021

OUR SCHOOLS



Kelly Lane Primary School
Grades PK-2
Enrollment: 403



Wells Road Intermediate School
Grades 3-5
Enrollment: 353



Granby Memorial Middle School
Grades 6-8
Enrollment: 422



Granby Memorial High School
Grades 9-12
Enrollment: 577

GOAL AREAS

Goal 1: Student Learning and Achievement

Improve student achievement, academic performance and opportunity at all grade levels and for all ability levels and decrease achievement gaps on the path to college and career readiness.

Strategic Initiatives:

- 1.A. Establish a clear and concise instructional and curricular framework which is vertically and horizontally aligned across the district.
- 1.B. Align standards, instruction, assessment and professional development for PK-12 curricular areas.
- 1.C. Continue to integrate digital learning tools and support technology infrastructure.
- 1.D. Ensure all students are supported in achieving at proficiency levels or higher on the state assessments by monitoring their growth and performance over time and providing high-quality effective instruction.
- 1.E. Ensure all students have the same access to instruction and supports and eliminate any barriers to success.
- 1.F. Continue to explore international programs and certificate-based programs that expand students' global competency.
- 1.G. Continue to develop the college and career process for Grades 6-12 as well as enhance developmental guidance and advisory structures to support college and career opportunities and the creation of Student Success Plans.
- 1.H. Ensure successful transition for children to preschool and into kindergarten and the early grades.
- 1.I. Develop a culture of data in which teachers gather and analyze a variety of data sources to inform instruction for their class as a whole as well as individual students.
- 1.J. Implement and use a data system that can store and collect formal and informal assessment information in an easy to view format and analyze multiple data points across time and subjects.
- 1.K. Analyze course offerings and utilization of courses offered including enrollments and staffing implications.
- 1.L. Embed the Vision of a Graduate in capstone projects and curriculum/learning expectations. Revise capstone projects to allow students an opportunity to exhibit learning in relation to the Vision of a Graduate at key grades.
- 1.M. Build SRBI systems to support all learners and match students with appropriate intervention programs and structures to accelerate progress for all learners.
- 1.N. Develop coaching philosophy and structures that lead to the expectation that each teacher will participate in a minimum of one (1) job-embedded formal coaching cycle each year.

Goal 2: Community Engagement

Enhance communication and build trusting relationships with all stakeholders.

Strategic Initiatives:

- 2.A. Develop a communication plan which infuses the use of technology to engage families and stakeholders for the purpose of gathering input, providing information, and increasing transparency to support student learning.
- 2.B. Continue to improve transition process for all new students entering the Granby Public Schools.
- 2.C. Continue to partner with college/university and other post-secondary programs and institutions to develop transition opportunities for students.
- 2.D. Develop a plan to engage alumni in the happenings of the Granby Public Schools.
- 2.E. Collaborate with the PTO, PAC, SEPTO, and Athletic Booster Clubs and create partnerships in supporting students and working with families to keep them apprised of school events and their child's learning.
- 2.F. Develop a district-wide plan for branding the district and each school individually in regard to logos, colors, mottos.
- 2.G. Grow the School-to-Career Program to develop relationships with community businesses that could providing mentoring, internships and shadowing experiences to students.



Goal 3: Safety and Social Emotional Well-Being

Foster a safe and positive social emotional environment for everyone.

Strategic Initiatives:

- 3.A. Fully implement a social and emotional well-being curriculum and behavioral expectations that provide a common experience for all learners and plans for intervention supports and crisis management for our students in need.
- 3.B. Expand student access to more social and emotional health services.
- 3.C. Require all school leaders to have a well-developed, effective strategies to promote positive and productive school climates and integrate restorative practices where appropriate.
- 3.D. Provide all staff with ongoing professional learning opportunities which focus on student social and emotional well-being.
- 3.E. Continue to seek ways to enhance the quality of athletics, visual and performing arts.
- 3.F. Strengthen ways to use advisory programs and initiate a new system to evaluate student experiences.
- 3.G. Continually review and enhance all safety and security protocols.



Goal 4: Budget Development and Fiscal Management

Practice responsible budget development and management through transparency and maximize available financial resources through a balance of fiscal discipline and innovative educational investments.

Strategic Initiatives:

- 4.A. Examine all new state mandates to determine funding sources and identify significant unfunded mandates as part of the district's legislative efforts.
- 4.B. Benchmark total compensation for staff and collaborate with the Board of Finance in long-range planning to assure the district can attract and retain talent that is commensurate with the high-quality educational environment reflected by our core values.
- 4.C. Ensure the use of cross-training processes across the district for ongoing, efficient operations across the district.
- 4.D. Implement facility condition assessment and educational suitability assessment including a technology analyses to provide a foundation for the district five-year capital outlay plan to provide safe, healthy and efficiently operated schools.
- 4.E. Continue to create a long-term financial plan which aligns with the vision of the Board of Finance and taxpayers.
- 4.F. Continue to seek town and regional partnerships as a way of being more efficient.
- 4.G. Utilize grant opportunities to maximize tax payer dollars and supplement services and programming in innovative ways.
- 4.H. Maintain replacement cycles for items such as textbooks, uniforms, musical instruments, furniture, and technology to allow for predictable expenses.
- 4.I. Continue to work with the Board of Selectmen and Board of Finance on large capital projects.



Goal 5: Embracing Diversity

Adopt and promote strong instructional, curricular and leadership practices that embrace and advance knowledge and acceptance of human diversity and that eliminate bias.

Strategic Initiatives:

- 5.A. Ensure system-wide practices and structures are in place to support implementation of the Granby Public Schools Anti-Bias/Anti-Racism Plan.
- 5.B. Ensure that individualized plans for students are written and implemented in a way that provides the appropriate levels of support while allowing the greatest access to the curriculum and classroom instruction that includes gifted and talented students.
- 5.C. Develop systems and structures that allow students to explore their interests and enrich their learning.
- 5.D. Work to engage the families of all Granby Public School students with both the school system and other families across communities including Granby, Hartford, and Hartland.
- 5.E. Provide professional learning opportunities for staff to build awareness and understanding of the needs of diverse learners.
- 5.F. Build staff capacity to utilize differentiated instructional and assessment practices to support diverse learning needs and increase engagement in the learning process.
- 5.G. Build student capacity for understanding themselves and others as learners and support student voice and advocacy in the school setting.
- 5.H. Examine our continuum of services at each level of learning and across our many disciplines to enhance programming and specialized instruction.
- 5.I. Create a positive and supportive environment in which all students have opportunities to safely express their viewpoints.
- 5.J. Continue to develop curriculum that incorporates multiple view points and perspectives and invest in materials that reflect the diversity of the community.



Goal 6: Professional Learning

Develop the instructional skills and strategies of our teaching staff through ongoing, meaningful and systemic professional learning opportunities.

Strategic Initiatives:

- 6.A. Design and implement a professional growth system that encompasses onboarding, mentoring, and continuous growth based on individual, school, and district needs.
- 6.B. Build employee capacity to collaborate and share accountability for outcomes.
- 6.C. Develop an educator evaluation process for targeted areas of growth, deliberate practice in order to increase teacher effectiveness.
- 6.D. Implement a common instructional framework that aims to increase student engagement utilizing clear shared outcomes, practices and feedback to promote complex thinking and transfer.
- 6.E. Ensure alignment with adopted programs by providing ongoing professional development, job-embedded coaching, and feedback from assessment data.
- 6.F. Create opportunities for PK-12 vertical/horizontal teams in all of the content areas to allow conversations and alignment with the discipline standards and ensure through lines in curriculum and instructional approaches.
- 6.G. Research and develop a leadership structure that most effectively and efficiently creates point people for each content area across multiple grades so that leadership can be provided in PLC meetings, curriculum development, resource selection, as well as in supporting teacher development.
- 6.H. Explore ways to utilize the expertise of our staff to provide opportunities for peer-to-peer learning and develop leadership in staff.
- 6.I. Utilize Professional Learning Communities as structures to enable collaboration around best teaching and learning practices based on data conversations.



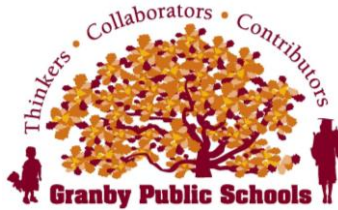

To: Board of Education

From: Jordan Grossman, Ed.D., Superintendent of Schools

Date: October 20, 2021

Re: Granby Association of School Administrators (GASA) Contract

The following is a summary of the major changes in the negotiated contract between the Granby Board of Education and the Granby Association of School Administrators (GASA) for the period July 1, 2022 through June 30, 2025:

Salaries:

- A budget impact of 2.36% in the first year of the agreement, 2.69% in the second year of the agreement and 2.95% in the third year of the agreement.
- The total increase over the three years of the contract is 8%, which equates to \$100,710.
- Levels were reduced within the salary schedule by adding the Elementary Principals to the level which contains the Middle School Principal and Director of Pupil Personnel Services.

Health Benefits

Employee premium sharing contributions to health insurance options for each year will be 20% in 2022-2023, 20.5% in 2023-2024 and 21% in 2024-2025. The dental premium sharing contribution will be 23% in 2022-2023, 23.5% in 2023-2024 and 24% in 2024-2025. Changes to the health care plan include a prescription co-pay and additional managed care parameters.

| | 2022-2023 | 2023-2024 | 2024-2025 |
|---------------|-----------|-----------|-----------|
| HSA | 20% | 20.5% | 21% |
| Dental | 23% | 23.5% | 24% |

Language Changes:

- There was a change in the seniority language pertaining to the reduction in force. In the event an administrator's position is eliminated, the Superintendent may assign administrators to available positions in any level, if in the judgment of the Superintendent such administrator is qualified to carry out the responsibilities of that position.
- Addition of the Juneteenth holiday beginning June 2022.
- Annual increase in the Board's contribution to a tax sheltered annuity plan 403(b) by \$500 per participant.

**Curriculum Subcommittee Meeting
October 6, 2021, 5:30 p.m.
Central Services**

Present:

Rosemarie Weber
Brandon Webster (via phone)
Sarah Thrall

Jennifer Parsons
Jordan Grossman

Absent:

David Peling

Member of the Public: N/A

Meeting commenced at: 5:40 p.m.

Meeting adjourned at: 6:45 p.m.

I. Public Comment: N/A

II. Assistant Superintendent's Monthly Report: Discussed updates including Equity Team Meeting and work groups; college and career planning bringing schools back to campus; first meeting of Social/Emotional Learning Committee and Wellness Committee which is a focus this year; and, preparing for professional development day next week.

III. Assessment Update: Discussion of types of assessments used at grade levels and plan to use more effectively for diagnostic and predictive purposes. Lengthy discussion on how STARS assessments correlate to SBAC testing and how to use PSAT – linking to College Board and Khan Academy to assist with instruction.

IV. Revised Policies:

- Policy 4118.237/4218.237/5141.8 – Face Masks/Coverings: Moved to full Board
- Policy 0200 – Vision-Mission-Goals: Stays in Subcommittee
- Policy 1110.1 – Communications with the Public: Stays in Subcommittee
- Policy 3542.43 – Food Service: Tabled
- Policy 4118.11/4218.11 – Personnel Nondiscrimination: Tabled
- Policy 4152.6 – Family and Medical Leave Act: Tabled
- Policy 4212.42 – Drug and Alcohol Testing for School Bus Drivers: Tabled

V. Teachers College Reading and Writing Project: K-5 model moving into 6th grade as well.

VI. Other: N/A

A motion was made by Brandon Webster and seconded by Rosemarie Weber to adjourn the meeting. This motion passed unanimously at 6:45 p.m.