

Large Capital Budget Meeting
Monday, January 17, 2011 7:00 PM
Central Services

I. Large Capital Budget Workshop

Attachments:

| | |
|-----------------------------------|----|
| Ed Spec Questions for BOE | 2 |
| Ed Specs for Athletic Fields | 4 |
| Ed Specs for Maint & Fac Bldg | 8 |
| FY-12-FY16 Large Capital Projects | 20 |

Rationale: The Board will have a workshop regarding large capital projects for FY12 and beyond.

To: Board of Education
From: Alan Addley, Superintendent of Schools
Date: January 13, 2011
Re: Large Capital Projects

Please find attached our large capital projects for discussion at Monday night's workshop. I have attached specifications and more fully developed details pertaining to the priority one projects (Maintenance and Facilities Building & Athletic Field Project). These documents and specifications represent the most up-to-date information, plans and preliminary cost projections. Should you need them for reference, I will have on hand copies of the GAFLAC report and proposed (not approved) site drawings.

I am hopeful that we can review these documents in detail and make some decisions that will allow us to move the projects forward. There are some details in these specifications, principles and plans that we need to reach consensus on before master plans can be finalized. Thereafter, we have enough information to forward to CPPAC. Since a lot of time has passed since the original design proposal and CR3 cost of the project, I would suggest utilizing the services of a consulting architectural firm (such as CR3) to update/complete the master plans and educational specifications.

I am providing the following principles, questions and next steps pertaining to the two main projects as some possible discussion points for Monday night's workshop.

Guiding Principles

- We have run out of space on HS/MS campus
- All athletic fields are constructed to meet standards of the Connecticut Interscholastic Athletic Conference.
- Ideally, varsity programs will be kept on campus.
- As some of the athletic program is already being accommodated off campus, we expect this to continue for a few sports.
- Any new facility must have associated support facilities (i.e., bathrooms, lighting, parking, signage, etc.)
- Incorporate two synthetic fields, one with lights, as part of any new athletic facility/upgrade.
- A new facility should maintain the character of the high school/middle school complex.
- Any land acquisition should be as centrally located as possible to the HS/MS campus.

Questions

- How do we resolve the question of whether or not the new athletic facility is on campus?
- There is no satisfactory provision in any plans to have athletic field house on site. Where should it be?

- What are the implications of having athletic facility and/or maintenance building on or off site?
- What do we do about parking? Does all parking have to be located on the HS/MS campus?
- Does the maintenance building have to be on the same plot of land as the new athletic fields?
- Should the project be phased in and, if so, how?
- Do we treat all sports/intramurals equally (all varsity teams on campus; some sports stay on campus, others are not)?

Next Steps

- Consideration of principles.
- Fine tune specifications for on-campus or off-campus facility for submission to CPPAC.
- Secure a consulting firm to fine tune the proposal and educational specifications.

ATHLETIC FACILITY SPECIFICATIONS

PROJECT HISTORY AND RATIONALE

Background:

The Granby Board of Education has identified the need for renovated and new athletic fields for many years. The NEAS&C High School Accreditation in 2007 also recommended the creation of an action plan that permanently addresses athletic facilities and field space. It has been the intention of the Granby Board of Education to respond to the continuing athletic challenge of a growing community.

In 2005, CR3 LLP developed an Athletic Fields Master Plan and conceptual plan for the Board of Education. The 2006 CPPAC submission included a project for a combined athletic field renovation and maintenance facility.

In 2007, the Granby Athletic Field Long-Range Advisory Committee (GAFLAC) was commissioned to work with Weston & Sampson by the Board of Selectmen to investigate a future plan for the athletic program. GAFLAC conducted its study and forwarded its recommendations and site plans to CPPAC. While not addressing all BOE concerns, the GAFLAC study is comprehensive and helpful in making future decisions regarding the athletic fields and facilities needs of the district and town.

In 2008-2009, the Board of Education developed a set of principles related to the further development of the Middle School/High School campus and to validate a set of educational specifications for expanded athletic facilities designed to optimally accommodate all known and anticipated athletic programs. This would include: playing surfaces both for practice and games, storage, parking, staff offices, and team and public locker/toilet facilities.

Existing Conditions and Facilities

The Granby Middle School/High School athletic fields occupy approximately 18 acres of land directly north and west of the school campus and are characterized by steep topography, proximity to wetlands and poorly drained soils.

- The existing campus has approximately half the land required to accommodate our existing MS/HS athletic requirements, per CIAC guidelines.
- Fields suffer from over use, lack of a proper maintenance program and/or lack of irrigation.
- In its current configuration, the site lacks space to accommodate parking requirements. Building a track/multi-sport turf field on the MS/HS site would require the addition of significant additional parking facilities. Initial plans called for the removal of the lawns in front of the middle school and in the oval in front of the main entrance. It is questionable whether or not this additional parking will provide adequate parking for large capacity events.

- Teams that play off campus lack facilities (changing rooms, bathrooms, parking).
- There is a lack of athletic storage. The high school is presently using two 40' trailers that were intended to be used as a short-term solution.
- Additional land (including possible land purchase and/or extensive use of Town parks) is required to satisfy basic additions to existing facilities.
- Although possible, any additional construction on HS/MS complex will be an extremely tight fit to accommodate a large athletic facility with parking and to do so will seriously impact campus aesthetics.

Principles:

- All athletic fields are constructed to meet standards of the Connecticut Interscholastic Athletic Conference.
- Ideally, varsity programs will be kept on campus.
- As some of the athletic program is already being accommodated off campus, we expect this to continue for a few sports.
- Any new facility must have associated support facilities (i.e., bathrooms, lighting, parking, signage, etc.)
- Incorporate two synthetic fields, one with lights as part of any new athletic facility/upgrade.
- A new facility should maintain the character and undesignated open spaces of the high school/middle school complex.
- Any land acquisition should be as centrally located to HS/MS campus.

PROJECT BUILDING NEEDS AND SPECIFICATIONS

Field Upgrades

Any new facility (on or off site) would require upgrades and renovations to existing on-site athletic facilities (fields/tennis courts/irrigation).

Athletic "Field" Facility

To meet the athletic programmatic needs of a 21st Century high school, there is a need to build a contemporary athletic facility that provides for:

- Six-lane track with eight lane straight-aways to meet CIAC design criteria;
- A lighted synthetic field for varsity soccer, lacrosse, football, and field hockey games and practices;
- A second synthetic practice field;
- Athletic field storage, sport team dressing rooms, restrooms, and a concession facility;
- Seating capacity for 900-1000 spectators; and, possibly,
- An off-site location where 10+ acres of land is available for either parking and/or offsite site fields.

Parking

The MS/HS campus has little room for athletic field expansion and parking to accommodate spectators attending major events. Existing parking availability limits spectator-seating capacity to 621 for any one event (presently 307 parking spaces). Any new facility should include parking provisions for up to 400 cars (900-1000 spectators). It is possible to add the additional 100 parking spaces by removing the lawns in front of the middle school and in the oval in front of the main entrance.

Athletic Buildings

Approximately 5,000 square feet is needed for athletic buildings at an approximate cost of \$100/square foot. The following building components are needed:

Offices: Two offices are required for use by coaches. Each office should be equipped with a desk and telephone. Each should have an inside restroom adjacent to the office with a handicapped access toilet and shower. (Approximately 500 square feet)

Concession Stand: A 500-square-foot concession stand will be needed for ticket sales and food/beverages sales.

Locker Rooms: Two locker rooms are required for student use. Each should include lockers, benches, showers, and a team area. (Approximately 1,600 square feet)

Outside Restrooms: Outside restrooms will be open to athletes and fans. The female restroom should include three stalls and 2 sinks. The male restroom should include two stalls, two urinals and two sinks. Both must be handicapped-accessible. (Approximately 600 square feet)

Storage:

An approximately 1,800-square-foot building is needed for athletic equipment.

Estimated Cost

| | |
|--|-------------|
| APPROXIMATE GROSS PROJECT COST: | \$5M - \$8M |
| LAND ACQUISITION COST (FIELDS AND/OR PARKING): | ~\$500 K |

Priority Category

This CPPAC submission is a Priority Category 1 project. The athletic facilities are needed to provide for athletic programs that cannot be offered with the existing facilities. Civil rights (handicapped accessibility) code violations will also be addressed. A preliminary cost estimate of the project is \$5M-\$8M.

Cost Estimates

| | <u>2005 Cost Estimates</u> | <u>Estimated Annual Escalator</u> | <u>2012 Cost Estimates</u> |
|--|------------------------------------|---|------------------------------------|
| Site Work, Utilities, Walkways, and Fields Area A | \$149,500 | 0% | \$171,776 |
| Site Work, Utilities, Walkways, and Fields Area B | 247,000 | 0% | 283,803 |
| Site Work, Utilities, Walkways, and Fields Area C | 319,250 | 0% | 366,818 |
| Track | 425,000 | 2% | 488,325 |
| Synthetic Field surface | 672,000 | 2% | 772,128 |
| Bleachers | 402,000 | 2% | 461,898 |
| Buildings | 150,000 | 0% | 172,350 |
| Lighting | <u>800,000</u> | 2% | <u>919,200</u> |
| | \$3,164,750 | | \$3,636,298 |
| Sod vs. seed | <u>63,875</u> | 2% | 73,392 |
| Subtotal | \$3,228,625 | | \$3,709,690 |
| 15% contingency | 484,294 | | 556,454 |
| Contractor O&P @20% | 742,584 | | 853,229 |
| Permits | <u>73,594</u> | | <u>73,594</u> |
| | \$4,529,097 | | \$5,192,966 |
| Tennis Courts (repaved and fenced) | 240,000 | 0% | 240,000 |
| Realign Entrance Road | 75,000 | 0% | 75,000 |
| Total Project per CR3 | \$4,844,097 | | \$5,507,966 |
| Add Second Synthetic Field | 672,000 | 2% | 772,128 |
| | \$5,516,097 | | \$6,280,094 |
| Add off-site parking 100 cars: land acquisition | | | 350,000 |
| Add offsite parking 100 cars: grade and pave | | | <u>400,000</u> |
| | | | \$7,030,094 |

MAINTENANCE AND FACILITIES BUILDING SPECIFICATIONS

PROJECT HISTORY AND RATIONALE

Background

The Board of Education first identified the need for a maintenance building with district storage in 2000. Since that time, the Granby district has demonstrated considerable growth. Current enrollment exceeds 2,300 students. The district owns 9 vehicles plus grounds equipment and employs 19.5 custodians and 4 maintenance workers. At the high school, storage and maintenance spaces used by the Facilities Department have been converted into classrooms, teacher spaces and offices. The 2007 NEAS&C High School Accreditation recommendations call for the provision of storage space that secures equipment and materials and that permanently addresses safety issues.

In 2007, the architectural firm of Weston & Sampson Engineers, Inc. was hired to put together a layout for a facilities building. The firm conducted a site survey of existing facility space and needs in order to design specifications for the facilities building.

Since that time, the district has explored several different options including shared use of the Town Garage. At this time, it appears that additional land will need to be purchased for an 11,500 square-foot maintenance building.

Existing Conditions and Facilities

Currently, the maintenance and custodial staff occupy a total of 6,078 square feet of space. The area consists of 3,600 square feet at the H.P.J. Construction Company at a cost of \$28,800 per year, 960 square feet of outdoor storage containers (3 trailers measuring 8'x40'), and 768 square feet of storage in the high school, and 750 square feet of office and secretarial file area in the high school.

The high school requires space currently used by the Facilities Department for educational programs and staff. Inadequate storage space has resulted in the use of hallways for storing equipment; an unsafe and inappropriate practice.

Outside storage containers were intended to be used as a short-term solution. They are unattractive, use valuable space on school grounds and are difficult to access.

Technology supplies and equipment are currently housed in outside storage containers and in the Central Services file room. A minimum of 600 square feet is needed for storing technology equipment and supplies.

There are inadequate storage facilities in the district for school drama programs. There is one small room at the high school (not the original design purpose of the room). Parents store stage props, costumes and materials at their homes.

Principles

- There is a need to garage all of our vehicles.
- The inclusion of adequate storage space for district facilities, technology and drama.
- A centralized storage facility is needed to support cost-effective purchasing and accurate inventory control.
- Adequate working space and environment for employees.

PROJECT BUILDING NEEDS AND SPECIFICATIONS

We envision a pre-fabricated metal building approximately 11,000 square feet. It may be possible to reduce the size slightly if mezzanine space can be utilized for storage within the garage bays.

Offices: The Lead Maintenance, Lead Evening Custodian and 3 maintenance workers will be housed in the new facility. The Lead Maintenance and Lead Evening Custodian can share an office. Lockers are needed for maintenance workers. A central file room is needed for blueprints and files. The Facilities Director and Administrative Assistant currently maintain office space at the Central Services building. If they were to be moved to the new facility an additional 2 offices would be needed.

Lunch Room: A lunch room with basic kitchen facilities at 360 square feet.

Shop: A carpentry shop area of approximately 900 square feet.

Restroom/Locker Room: Restrooms (male & female) and shower/locker rooms at 778 square feet.

Parking: A minimum of 12 spaces is needed for employees and visitors to the facility.

Garage Bays: Garage bay space of 4,080 square feet is required for six maintenance vehicles (vans and trucks), one landscape trailer, and one school van. Space is also required for plows, lawn mowers, lawn equipment (leaf blowers, rototiller, and trimmers) and custodial equipment (strippers, buffers, etc.). Garage doors must be a minimum of 12' high.

Storage: A loading dock (20 feet wide) is needed to provide access to storage areas. In addition to storage for technology and maintenance equipment, this facility will house cleaning products, paper products, floor finishing products, HVAC filters, and electrical, plumbing and maintenance supplies. Storage area will be 2,100 square feet with a mezzanine area of 720 square feet. An area of 240 square feet is being requested by the drama department for storage of props.

HVAC: The office area and selected storage areas require heat and air conditioning. The shop area and additional storage areas require heat only.

Estimated Cost

| | |
|---------------------------------|----------|
| Cost per square foot | \$130 |
| APPROXIMATE GROSS PROJECT COST: | \$1.5M |
| LAND ACQUISITION COST | ~\$300 K |

Priority Category

This CPPAC submission is a Priority Category 1 project.

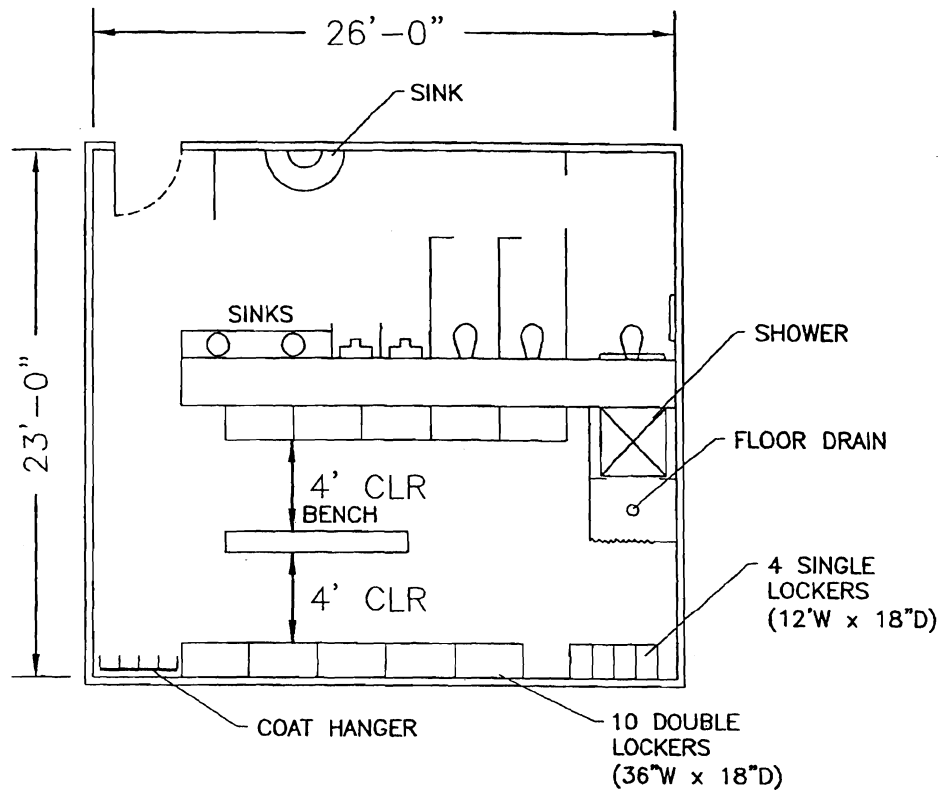

MALE LOCKER/SHOWER/TOILET
 $23' \times 26' = 598 \text{ SF}$

GRANBY, CONNECTICUT
 AUGUST 08
 BOE SPACE NEEDS ASSESSMENT

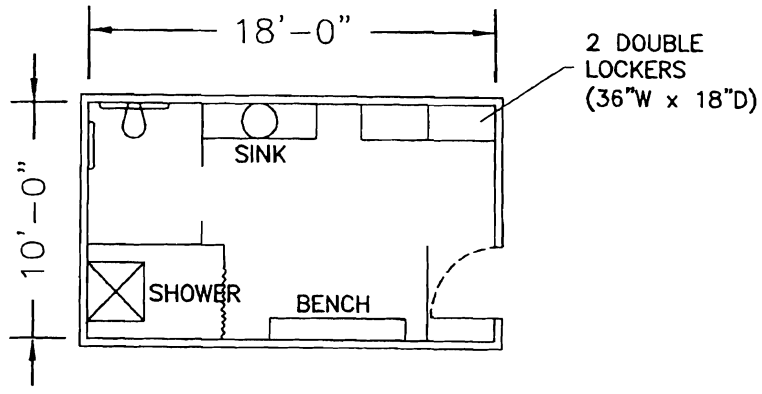

FEMALE LOCKER/SHOWER/TOILET
 10' x 18' = 180 SF

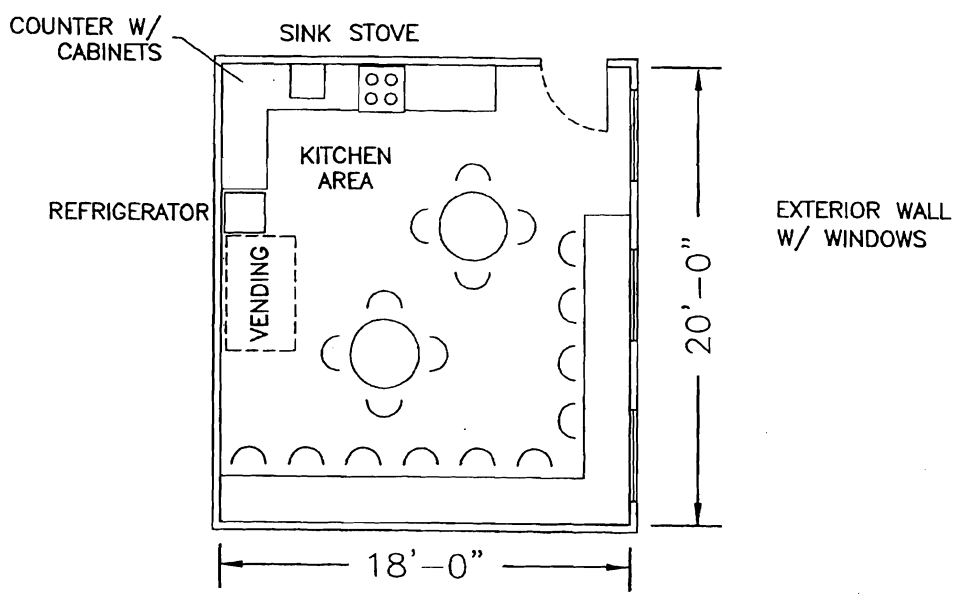

WORK FORCE LUNCH ROOM
 18' x 20' = 360 SF

GRANBY, CONNECTICUT
 AUGUST 08
 BOE SPACE NEEDS ASSESSMENT

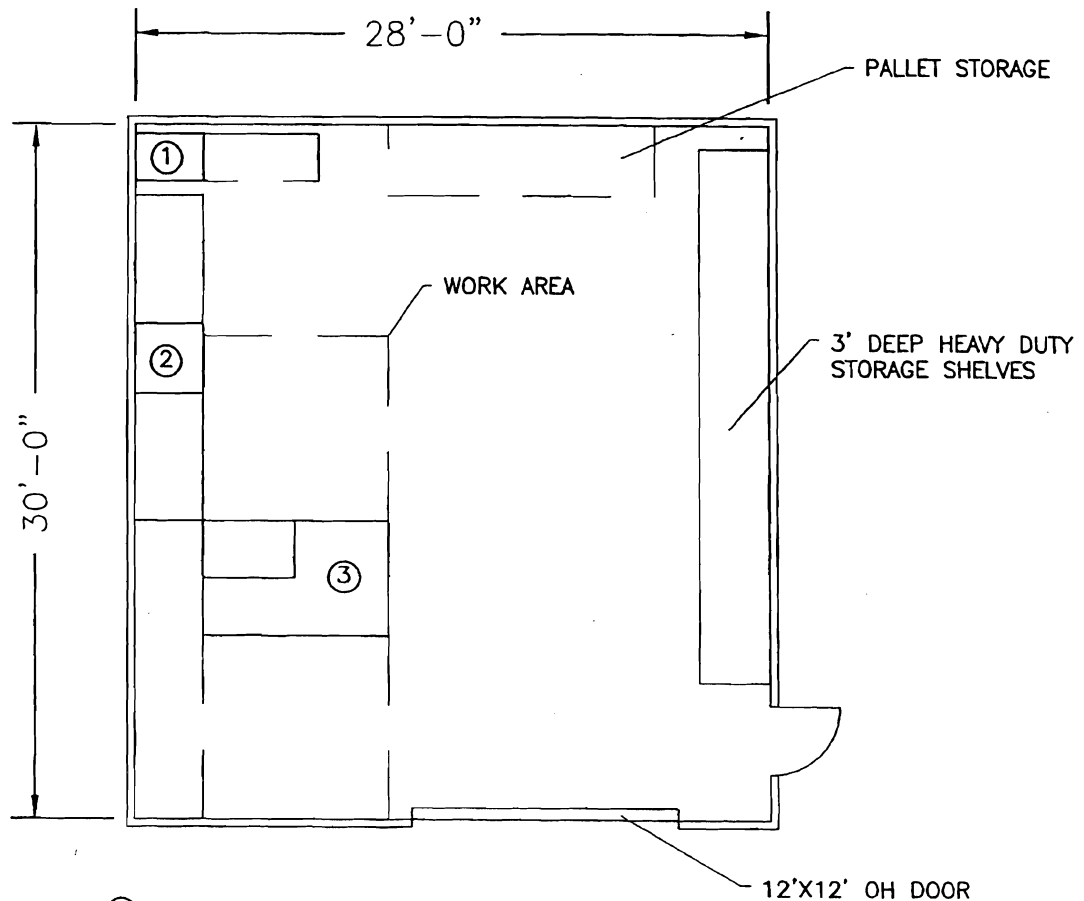

- ① BAND SAW
- ② BENCH MOUNTED CHOP SAW
- ③ TABLE SAW

CARPENTRY SHOP

28' x 30' = 840 SF

GRANBY, CONNECTICUT
 AUGUST 08
 BOE SPACE NEEDS ASSESSMENT

Scale: 1/8"=1'-0"

Sheet 6

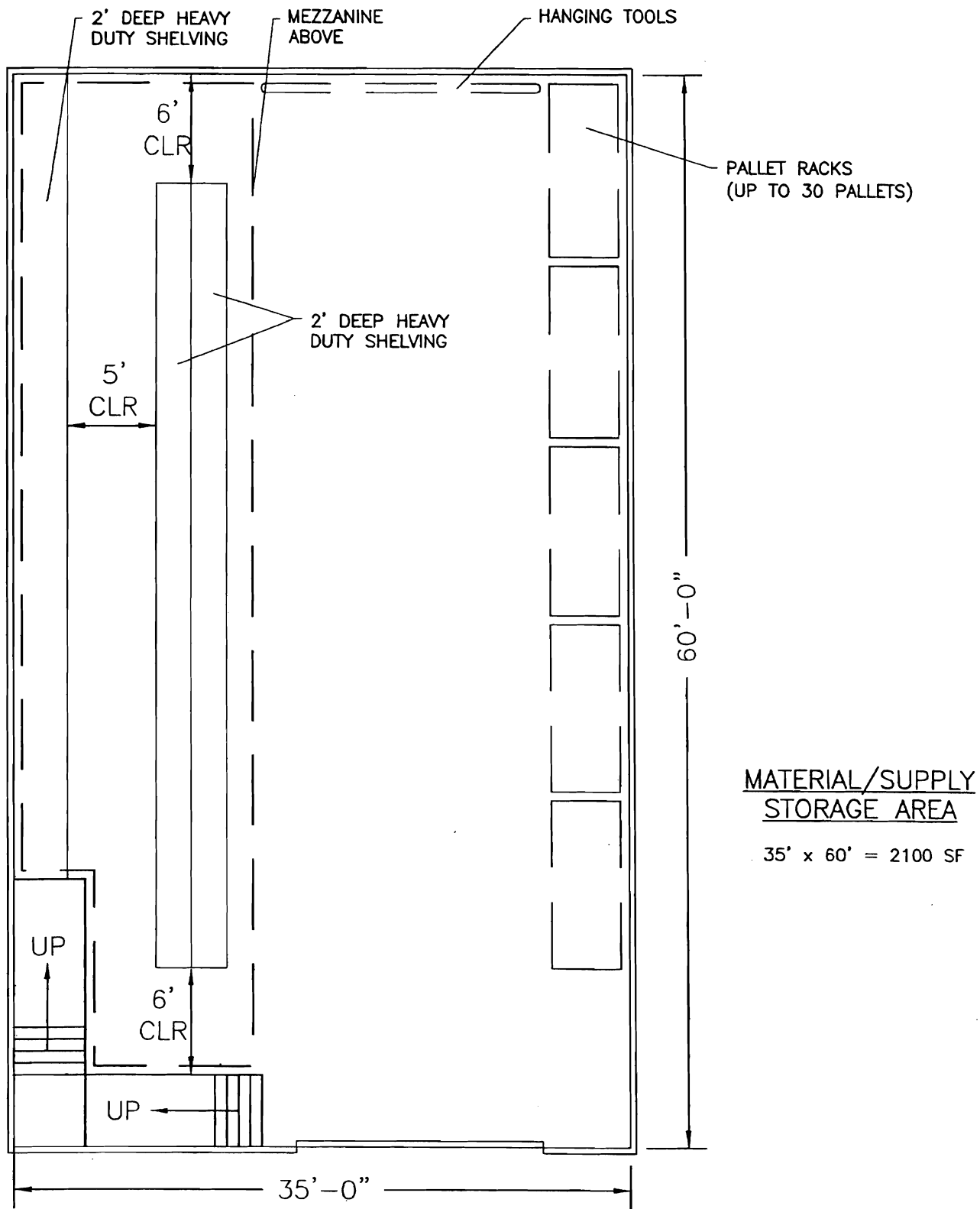

GRANBY, CONNECTICUT

AUGUST 08

BOE SPACE NEEDS ASSESSMENT

Scale: 1/8"=1'-0"

Sheet 7

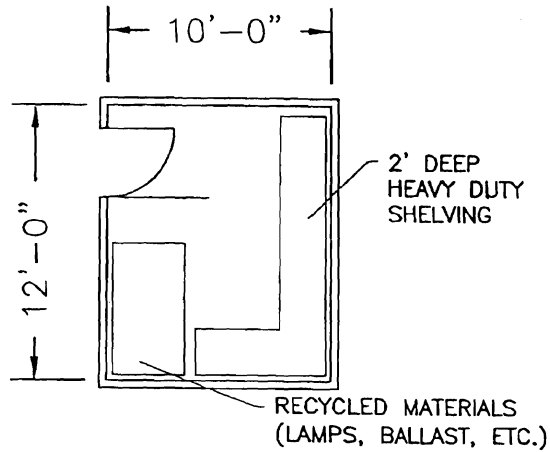

HAZARDOUS MATERIAL ROOM

10' x 12' = 120 SF

GRANBY, CONNECTICUT

AUGUST 08

BOE SPACE NEEDS ASSESSMENT

Scale: 1/8"=1'-0"

Sheet 8

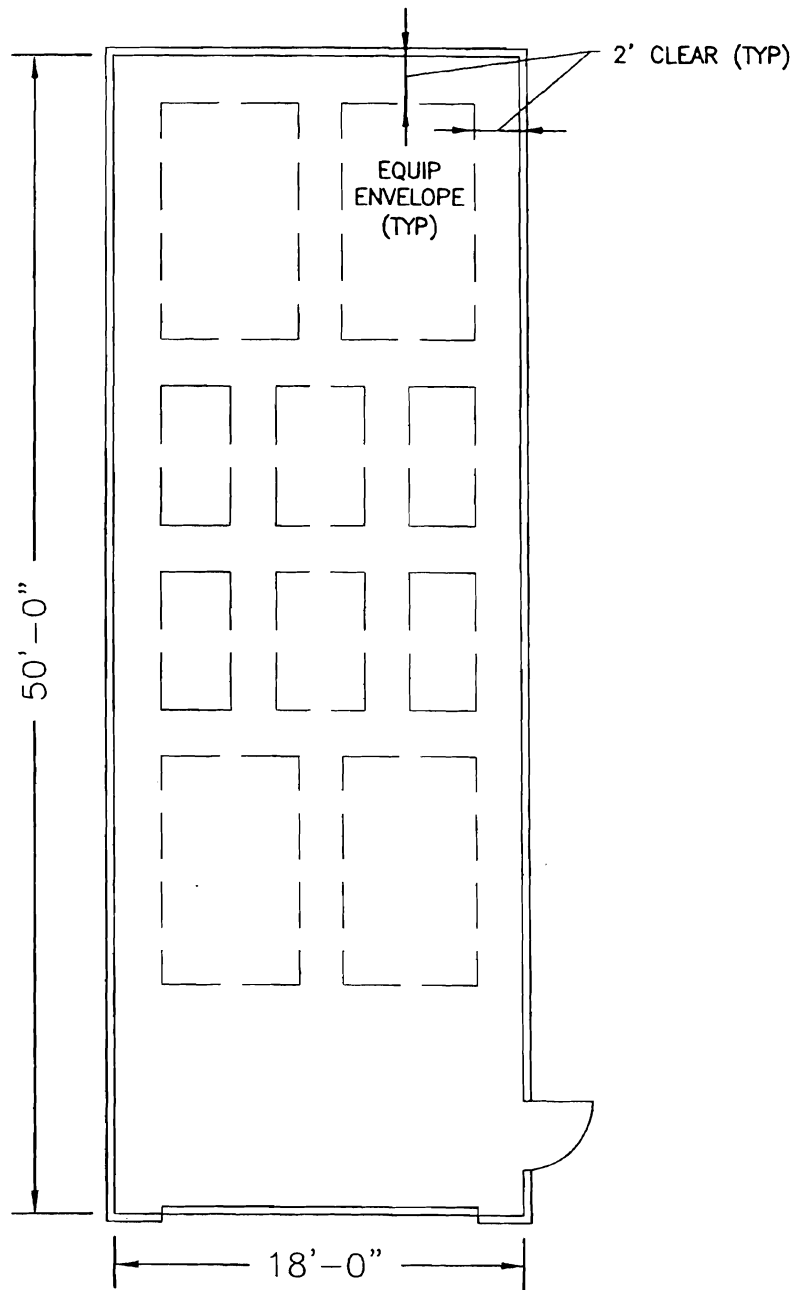

SMALL EQUIPMENT STORAGE

18' x 50' = 900 SF

GRANBY, CONNECTICUT

AUGUST 08

BOE SPACE NEEDS ASSESSMENT

Scale: 1/8"=1'-0"

Sheet 9

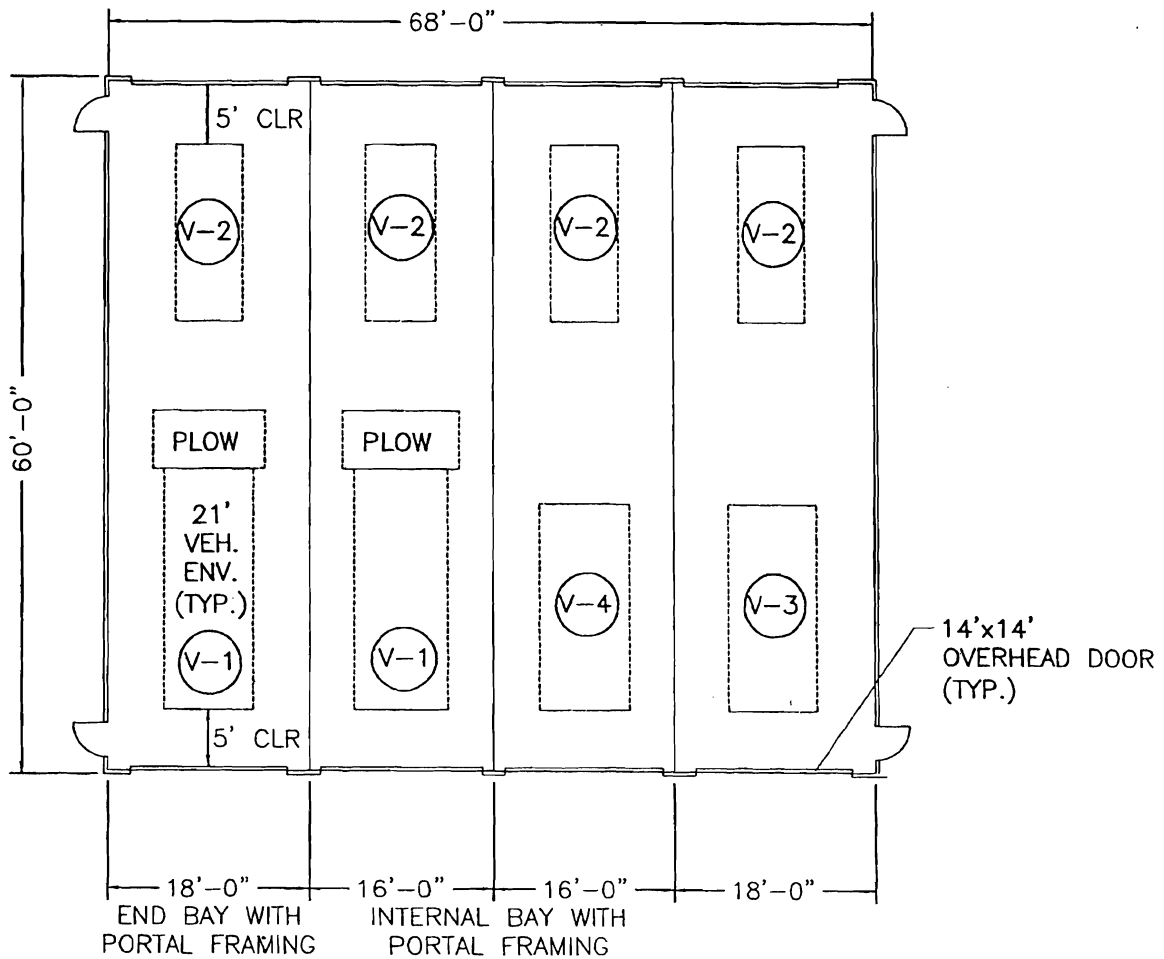

VEHICLE LIST

- V-1 : PICKUP TRUCK WITH PLOW
- V-2 : VAN
- V-3 : STUDENT TRANSPORT VAN
- V-4 : TRAILER

VEHICLE STORAGE AREA

60' x 68' = 4080 SF

NOTE: KITCHEN VAN
AND TECHNOLOGY VAN STORED
OUTSIDE

GRANBY, CONNECTICUT
AUGUST 08
BOE SPACE NEEDS ASSESSMENT

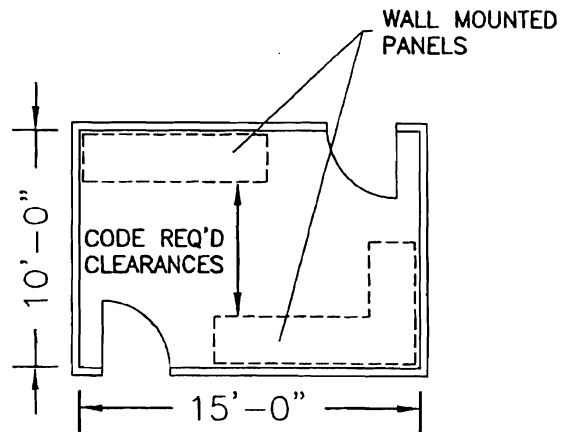

ELECTRIC ROOM
 10' x 15' = 150 SF

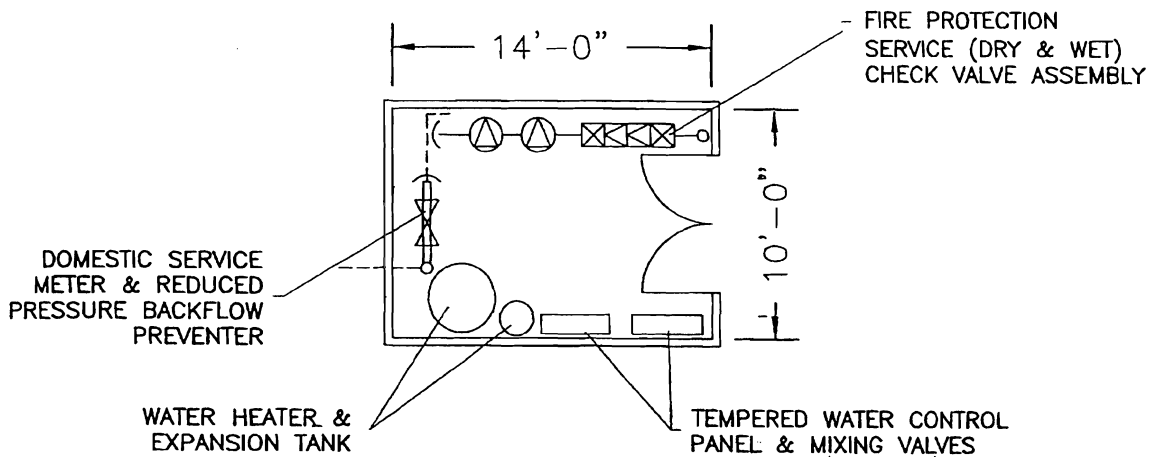

PLUMBING/FIRE PROTECTION ROOM
 10' x 14' = 140 SF

GRANBY, CONNECTICUT

AUGUST 08

BOE SPACE NEEDS ASSESSMENT

Scale: 1/16" = 1'-0"

Sheet 11

Town of Granby CT
 Department of Public Works / Board of Education
 Space Needs Summary
 August 2008

Building Requirements

| Area | Description | Size (SF) | Sheet No. | Ref No. | Room / Area Dimensions | | |
|-----------------|---------------------------------|-----------|-----------|-----------|------------------------|--|-------|
| | | | | | length | width | size |
| DPW Space Needs | Vehicle Storage Area | 1,540 | 1 | D 0.00 | 22 | 70 | 1,540 |
| | Wash Bay | 1,750 | 2 | D 4.03 ** | 25 | 70 | 1,750 |
| | Wash Equipment Room | 360 | 2 | D 4.03 ** | 18 | 20 | 360 |
| | Small / Towed Equipment Storage | 5,600 | 3 | D 0.00 | 70 | 80 | 5,600 |
| | Subtotal: | 9,250 | | | | | |
| | Area Grossing Factor (5%): | 463 | | | | | |
| | Circulation: (included) | | | | | | |
| | TOTAL: | 9,713 | | | | | |
| | Requested: | 8,480 | | | | | |
| | | | | | | | |
| BOE Space Needs | Male Locker/Shower/Toilet | 598 | 4 | B 1.09 | 23 | 26 | 598 |
| | Female Locker/Shower/Toilet | 180 | 5 | B 1.11 | 10 | 18 | 180 |
| | Workforce Lunch Room | 360 | 5 | B 2.07 | 18 | 20 | 360 |
| | Carpentry Shop | 840 | 6 | C 1.06 | 28 | 30 | 840 |
| | Material/Supply Storage Area | 2,100 | 7 | D 0.00 | 35 | 60 | 2,100 |
| | Hazardous Material Storage Area | 120 | 8 | C 9.16** | 10 | 12 | 120 |
| | Small Equipment Storage Area | 900 | 9 | C 9.02** | 18 | 50 | 900 |
| | Vehicle Storage Area | 4,080 | 10 | D 2.08 | 60 | 68 | 4,080 |
| | Electric Room | 150 | 11 | B 5.01 | 10 | 15 | 150 |
| | Plumbing/Fire Protection Room | 140 | 11 | B 5.02 | 10 | 14 | 140 |
| | Subtotal: | 9,468 | | | | | |
| | Area Grossing Factor (10%): | 947 | | | | | |
| | Circulation (10%): | 1,041 | | | | | |
| | TOTAL: | 11,456 | | | | | |
| Requested: | 8,060 | | | | | (plus lunchroom/restrooms/lockerspace) | |
| | | | | | | | |

**Summary of Large Capital Projections
FY12 – FY16**

1. Maintenance and Facilities Building
2. Athletic Field Project (includes purchase of land)
3. Technology Upgrades
4. High School Electronics Lab
5. Wells Road Playing Field
6. Energy-Saving Initiatives (Solar panels, energy efficiency program)
7. Roof Replacement Schedule
8. High School Facilities Upgrades:
 - (a) Kitchen
 - (b) Air Conditioning (commons, foods lab, computer lab, locker rooms facilities office and athletic director's office)
 - (c) High School Tennis Courts
 - (d) Emergency Generator
9. F.M. Kearns School Facility Renovation (Core facilities, kitchen, integrated pre-school, and full-day kindergarten)

| Project | Rec Priority | Gross Cost* | Net Cost | Start Up | Ongoing | Projected Completion | Status |
|--|--------------|---------------|---------------|-------------|----------|--------------------------|-------------|
| Maintenance and Facility Building | 1 | \$1,500,000 | TBD | | | Fall 2013 | Concept |
| Athletic Field Project | 1 | \$5M - \$8.5M | \$5M - \$8.5M | Summer 2012 | | 2012 - 2013 | Concept |
| Technology Upgrade | 1 | \$459,000 | | | | Fall 2012 Spring 2012 | Concept |
| High School Electronics Lab | 1 | \$164,400 | TBD | Summer 2011 | | | Concept |
| Wells Road Playing Field | 2 | \$75,000 | \$75,000 | | \$2,500 | Summer 2013 & beyond | Concept |
| Energy-Saving Initiatives | 3 | TBD | TBD | | | Fall 2013 & beyond | Concept |
| Roof Replacement | 3 | TBD | TBD | | | 2013 & beyond | Placeholder |
| High School | 3 | \$1,350,000 | TBD | \$25,000 | \$12,000 | 2014 & beyond | Concepts |
| F.M. Kearns School Facility | 3 | \$5,000,000 | \$3,150,000 | \$81,000 | \$32,000 | 2014 & beyond | Concept |

GRANBY BOARD OF EDUCATION
Capital Project Summary

PROJECT NAME: Maintenance and Facilities Building

PROJECT SUMMARY: The Board of Education first identified the need for a maintenance building with district storage in 2000. Since that time, the district has explored several different options including shared use of the Town Garage. At this time, it appears that additional land will need to be purchased for an 11,500 square foot maintenance building.

The 11,500 square feet is needed for district storage and maintenance department needs. Currently the maintenance and custodial staff occupy a total of 9,678 square feet of space. The area consists of 7,200 square feet at the H.P.J. Construction Company, 960 square feet of outdoor storage containers (3 trailers measuring 8'x40'), and 768 square feet of storage in the high school, and 750 square feet of office and secretarial file area. In addition to this space, the project includes additional space for a lunchroom, restrooms and locker rooms. The athletic field project includes 1,800 square feet of sports storage space that is not included in the 11,500 square feet requested here.

An architect firm has designed a preliminary layout of the building. Further professional services are needed to confirm space requirements, and develop schematic drawings and professional cost estimates.

PROJECT CATEGORY: ___Placeholder Concept ___Fully Defined ___Priority

REFERENDUM: Fall 2012
PROJECT START: Spring 2013
PROJECT ON LINE: Fall 2013

PROJECT BENEFITS:

- The high school requires space currently used by the facilities department for educational programs and staff. Inadequate storage space has resulted in the use of hallways for storing equipment. This project will help address that safety concern.
- The new building will allow for centralizing equipment and supplies in one location. A centralized storage facility will support more cost-effective purchasing and better inventory control. The technology department is also in need of storage area and space will be allocated for their equipment and supplies on a mezzanine in the material supply storage area. Storage space will also be provided for the drama department to storage props.
- A centralized storage facility will support more cost effective purchasing and better inventory control for maintenance supplies, technology equipment and supplies.

LEGAL REQUIREMENTS:

- Connecticut State Department of Education School Construction Grant Program is unlikely
- State and local code compliance

IMPACT OF NOT PROCEEDING/DELAYING: Facilities will continue to be rented for storage and maintenance, efficiencies will not be realized.

APPROXIMATE GROSS PROJECT COST (Professional estimate is needed) \$1,500,000

- Purchase land for building
- Purchase/construction of pre-engineered metal building \$160/sq. ft.
- Complete site work
- Build out offices, and bathroom facilities
- Equipment/shelving/miscellaneous start-up costs

PROJECTED NET PROJECT COST:

TBD

GRANBY BOARD OF EDUCATION
Capital Project Summary

PROJECT NAME: Athletic Field Project

PROJECT SUMMARY:

The 2006 CPPAC submission included a project for a combined athletic field renovation and maintenance facility. Granby Athletic Field Long-Range Advisory Committee (GAFLAC) was commissioned to investigate a future plan for the athletic program. GAFLAC has conducted a study and has forwarded its recommendations to CPPAC.

Presently, the GAFLAC recommendations, while helpful, do not fully meet the athletic needs of the district. To meet the athletic programmatic needs of a 21st Century high school, there is a need to build a contemporary athletic facility that provides for:

- Six-lane track with eight lane straight-aways to meet CIAC design criteria;
- A lighted synthetic field for varsity soccer, lacrosse, football, and field hockey games and practices;
- A second synthetic practice field;
- Athletic field storage, sport team dressing rooms, restrooms, and a concession facility;
- Seating capacity for 900-1000 spectators;
- An off-site location where 10+ acres of land is available;
- Adequate parking to accommodate spectators;
- Two offices for coaching staff;
- Concession stand, locker rooms and outside restrooms; and,
- Approximately an 1,800 square-foot building for storage of athletic equipment.

PROJECT CATEGORY: Placeholder Concept Fully Defined Priority

REFERENDUM: Fall 2011
PROJECT START: Spring 2012
PROJECT ON LINE: 2012 2013

PROJECT BENEFITS:

- The sports program, town recreational program and community will be improved through the addition of adequate playing fields.

LEGAL REQUIREMENTS:

- Connecticut State Department of Education School Construction Grant Program (limited funding)
- State and local code compliance

IMPACT OF NOT PROCEEDING/DELAYING: Facilities will continue to be rented for storage and maintenance needs. The sports program will be negatively impacted by inadequate playing field.

APPROXIMATE GROSS PROJECT COST: **\$5M - \$8M**
LAND ACQUISITION COST (FIELDS AND/OR PARKING): **≈ \$500,000**

PROJECTED NET PROJECT COST: **\$5M - \$8.5M**
We estimate no reimbursement pending review by SDE

GRANBY BOARD OF EDUCATION
Capital Project Summary

PROJECT NAME: Technology Upgrade

PROJECT SUMMARY: The district has identified the need for technology upgrades in several different areas. These have been combined into a single project.

Wireless Network Expansion: (District)

21st century school buildings require network/internet connectivity that support daily operations and interactive educational efforts which help to optimize learning and collaboration among the students, faculty, and administrative staff. Following on the success of wireless Lans (wLans) in higher education, an increasing number of k-12 schools are integrating wireless and mobile technologies to meet daily instructional demands by providing more users access to resources. Increasing wireless capabilities allow for rapid network expansion in particular at the high school, middle school, and Kearns school where future expansion requires rewiring in classrooms, wired connections are prohibitively difficult to run, and computer lab space is limited. Wireless connectivity allows more user access than with wired technology. Wireless expansion provides optimized performance, an economical cost savings associated with the expansion itself, and the needed mobility for present and future classroom network/internet access. Expansion eliminates many of the logistical issues that IT and teachers contend with due to the lack of placement and/or positioning of internet drops and power outlets in classrooms also helping to eliminate trip and safety hazards associated with data cabling strung across floors or under/around desks. A centralized system is necessary to provide high-density/high-quality public and private wireless access in a safe and secure manner through the use of bandwidth management, access control, maintenance tools and technologies. (\$200,000)

Digital Video Distribution: (District)

Video distribution systems in several buildings are failing and/or require costly upgrades. Currently classrooms at the High, School, Middle, School, and Kearns School have limited or no access to live television, recorded media, and/or an inability to broadcast their news programs. Systems at Kelly Lane and Wells Road have become obsolete and will require costly upgrades. A district solution to digital video distribution and content management is needed to support the learning environment. (\$125,000)

Additional Computer Labs: (High School, Middle School)

With the increasing use of technology each school has also identified the need for additional computer labs accessible to classroom teachers for academic courses. These needs could be addressed through the use of either desktop or mobile computers. Included are 3 new mobile labs at a projected cost of \$18,000 per lab. Desktops and wiring would cost \$25,000 per lab. (\$54,000)

Security Camera System Upgrades: (District)

The COPS grant awarded in FY2007 paid for the basic infrastructure and wiring of all schools with a minimum level of internal security cameras. This project includes an upgrade that will provide additional video storage and coverage of school public areas and school exteriors. Coverage in more areas will provide additional school security. Additional storage will allow saving identified incidents for police review beyond the current capacity of about 5 days. (\$65,000)

Middle School Clock System:

Television sets used to display the time in classrooms are old and failing. Replacing the TV's with a battery-operated wireless satellite clock system will allow us to obsolete the TV's rather than replace them. (\$15,000)

PROJECT BENEFITS:

- Replacement of outdated infrastructure
- Addition of computer labs to provide better access to electronic resources and aid instruction
- Improved school security and reduced vandalism.

PROJECT CATEGORY: Technology

Placeholder Concept Fully Defined Priority Ranking

REFERENDUM: Fall 2011

PROJECT START: Summer 2012

PROJECT ON LINE: Fall 2012

RELATED PROJECTS: COPS Grant Phase 1

HEALTH AND SAFETY IMPACT: A large part of the project addresses safety and security needs.

IMPACT OF NOT PROCEEDING/DELAYING: Failing infrastructure will have to be addressed in other ways and instructional upgrades will be delayed.

PROJECTED PROJECT COST: \$459,000

**GRANBY BOARD OF EDUCATION
Capital Project Summary**

PROJECT NAME: High School Electronics Lab

PROJECT SUMMARY: The district has identified the need for an Electronics Lab at the High School. Current facilities are inadequate. Increasing enrollment in technology courses necessitates larger, safer and updated facilities. The current electronics lab does not provide for the programmatic needs of the curriculum. The project would involve new construction and several modifications to existing spaces within the High School.

Electric \$20,000
Provide new electrical circuits for computers and related equipment in the classrooms. Add indirect lighting for the new classrooms and expansion of existing audio/visual fire alarm system.

Plumbing \$10,000
Additional sinks will be required for the Applied Electronics Lab. Modifications to the existing sprinkler systems so additional sprinkler heads can be added to the new classroom.

HVAC \$45,000
Air conditioning for three classrooms to accommodate the proper room conditions for the related equipment. A new ventilating system will be added to the Applied Electronics Lab

Construction \$25,000
Construct a new classroom in the woodshop area and additional modifications to existing classrooms

Technology \$64,400
Purchase software, hardware, and computers to support modifications to classrooms and new lab

PROJECT BENEFITS:

- Support the District's vision to engage students in critical thinking and real-world problem solving through the simulation of authentic learning tasks found in actual work settings.
- Support students' interest in STEM (Science, Technology, Engineering and Mathematics) careers.
- Provides space for collaborative work stations, lab experience and adequate space for additional technology and tools.
- Safer facilities.

PROJECT CATEGORY:

Placeholder Concept Fully Defined Priority Ranking

REFERENDUM: Fall 2011

PROJECT START: Summer 2011

PROJECT ON LINE: Spring 2012

RELATED PROJECTS:

HEALTH AND SAFETY IMPACT:

IMPACT OF NOT PROCEEDING/DELAYING:

- Limiting potential of students to be competitive in the high end fields of math and science

PROJECTED PROJECT COST: \$164,400

**GRANBY BOARD OF EDUCATION
Capital Project Summary**

PROJECT NAME: Wells Road Playing Field

PROJECT SUMMARY: Land behind Wells Road School was donated to the town in 2009. In order to develop 5.6 acres of this area for use as field space, the area must be cleared of trees, a temporary road installed and the field leveled and seeded.

PROJECT CATEGORY:

Placeholder Concept Fully Defined Priority Ranking

REFERENDUM: Fall 2012

PROJECT START: Spring 2013

PROJECT ON LINE: Summer 2013

PROJECT BENEFITS:

- Expanded playground activities and possibly baseball and/or soccer field use.
- Additional resource for the town.

LEGAL REQUIREMENTS:

- State and local code compliance.

IMPACT OF NOT PROCEEDING/DELAYING: Donated land will sit idle.

PROJECTED GROSS COST: **\$ 75,000**

PROJECTED NET CAPITAL COST: **\$ 75,000**

**GRANBY BOARD OF EDUCATION
Capital Project Summary**

PROJECT NAME: Energy-Saving Initiatives

PROJECT SUMMARY: The district has identified the need for a number of different energy initiatives. They are included for future consideration. Components of the project may need to be divided into individual projects in order to pursue grant funding.

- 1. Connecticut Clean Energy Fund: TBD**
It is recommended that the Town of Granby and Granby Public Schools work together to earn the designation as a CT Clean Energy Community by meeting three requirements:
1) committing to purchasing 20% clean energy by the year 2010, 2) having a threshold number of residents and small businesses sign up for the CT Clean Energy Options program and 3) making a municipal clean energy purchase. The result would be a solar energy array to be installed on the municipal building of our choice.

- 2. Energy Efficiency Program: TBD**
Maximize our options for energy strategy and long-term planning. Investigate resources that will allow new energy efficient equipment, savings, plus future cost avoidance through existing energy programs with utility companies.

- 3. Emergency Generator: \$200,000**
The installation of an emergency generator at the high school will help address both school and community emergency needs and will also yield approximately \$10,000 in savings each year through a load management program. If grant funding is available, the net cost would be lowered to \$140,000.

- 4. Solar Panels: \$855,000**
Look at the feasibility of using photovoltaic panels and solar panels for hot water.

PROJECT BENEFITS:

- Better climate for learning
- Reduction in ongoing energy costs and reduction in energy usage

PROJECT CATEGORY: Energy Initiatives
 Placeholder Concept Fully Defined Priority Ranking

REFERENDUM: Fall 2013
PROJECT START: Summer 2014
PROJECT ON LINE: Summer 2014

HEALTH AND SAFETY IMPACT: Improved emergency preparedness and better ventilation/climate

IMPACT OF NOT PROCEEDING/DELAYING:

PROJECTED PROJECT COST: TBD

**GRANBY BOARD OF EDUCATION
Capital Project Summary**

PROJECT NAME: High School Kitchen and Facilities Upgrade

PROJECT SUMMARY: With high school enrollment projected to stabilize at approximately 750 students, a kitchen is needed for a quality hot lunch program. Currently, lunch is transported from the Middle School kitchen and served in the high school Commons. This cost projection includes the construction of a 2,000 square foot addition on the end of the Commons and necessary equipment and appliances.

Also, there are number of other needs, including air conditioning, sidewalk, and refurbishment of the tennis courts. Areas that need to be air conditioned: Commons, food labs, computer labs, locker rooms, facilities office, and athletic director's office. Six (6) tennis courts are in need of repaving.

PROJECT CATEGORY: ___Placeholder Concept ___Fully Defined ___Priority

REFERENDUM: TBD

PROJECT START: TBD

PROJECT ON LINE: TBD

PROJECT BENEFITS:

- A higher quality hot lunch program will be offered.
- An adequate number of classrooms will be provided for students.

LEGAL REQUIREMENTS:

- Connecticut State Department of Education School Construction Grant Program
- State and local code compliance

HEALTH AND SAFETY IMPACT: More inviting, nutritional meals will be served.

IMPACT OF NOT PROCEEDING/DELAYING: Food continues to be transported from the Middle School, limiting meal choices.

| | | |
|---|------------|--------------------|
| APPROXIMATE GROSS PROJECT COST: | | \$1,350,000 |
| • Kitchen Construction (2,000 sq.' @ \$220) | \$ 475,000 | |
| • Kitchen equipment/fixtures | \$ 300,000 | |
| • Air conditioning | \$ 375,000 | |
| • Repave 6 tennis courts | \$ 200,000 | |

NEW ONGOING COSTS: **\$12,000**

START-UP COSTS: **\$25,000**

APPROXIMATE NET PROJECT COST: **\$TBD**

- Projected at 35% SDE reimbursement; 90% eligible costs

**GRANBY BOARD OF EDUCATION
Capital Project Summary**

PROJECT NAME: F.M. Kearns School Facility Addition

PROJECT SUMMARY: Even with updated enrollment projections showing a decline in primary enrollment projections, core facilities will be needed. The Board of Education is currently conducting an early childhood feasibility study. The potential addition of an integrated pre-school and full-day kindergarten may also necessitate additional classrooms. The project includes code compliance issues. Details are outlined in Educational Specifications adopted by the BOE and forwarded to the CT SDE by the Town of Granby in June 2002. Professionally developed cost estimates that were based on 2002 construction costs have escalated. If delayed, project costs should be escalated by 4% per year.

PROJECT CATEGORY: Addition

Placeholder Concept Fully Defined Priority Ranking

REFERENDUM: TBD

PROJECT START: TBD

PROJECT ON LINE: TBD

PROJECT BENEFITS:

- Core facilities designed to meet educational needs
- Classrooms added for student enrollment (10 sections per grade level)

LEGAL REQUIREMENTS:

- Connecticut State Department of Education School Construction Grant Program
- State and local code compliance

RELATED PROJECTS:

HEALTH AND SAFETY IMPACT: Facilities will meet all new code requirements.

IMPACT OF NOT PROCEEDING/DELAYING: Temporary classrooms will be leased at a cost considerably higher than the cost of permanent construction. The educational environment will not be appropriate for elementary age children.

PROJECTED PROJECT COST: **\$ 5,000,000**

NEW ONGOING COSTS: \$ 32,000

START-UP COSTS: \$ 81,000

PROJECTED NET CAPITAL COST: **\$3,150,000***

90% of project at 45.71% reimbursement. Costs adjusted to FY11.