

**Finance/Personnel/Facilities Subcommittee Meeting
Wednesday, June 2, 2010 5:30 PM
Finance/Personnel/Facilities Subcommittee Meeting**

I. April and May Statement of Accounts

II. Update on Middle School Grading Policy

III. Lunch Bid Award

IV. Possible Energy Efficiency Project

V. Maintenance and Facility Ed Specs

Attachments:

Facilities Ed Specs

2

VI. Wells Road Track

VII. Other

To: BOE

From: S. Camarotti

Date: June 2, 2010

RE: Proposed BOE Facilities Building

The architectural firm of Weston & Sampson Engineers, Inc. was hired to put together a layout for a facilities building. The firm compiled information from meetings held at the Town Hall and doing a site survey of existing facilities space.

Currently the maintenance and custodial staff occupy a total of 9,678 square feet of space. The area consists of 7,200 square feet at the H.P.J. Construction Company, 960 square feet of outdoor storage containers (3 trailers measuring 8' X 40'), and 768 square feet of storage in the High School, and 750 square feet of office and secretarial file area. In addition to this space we asked for additional space for a lunchroom, restrooms, and locker rooms.

The new building will allow for centralizing equipment and supplies in one location. A centralized storage facility will support more cost effective purchasing and better inventory control. The technology department is also in need of storage area and space will be allocated for their equipment and supplies on a mezzanine in the material supply storage area. Storage space will also be provided for the drama department to store props.

Building components will include the following:

- Male Locker/Shower/Toilet, 23'X26', 598 sq. ft.
- Female Locker/Shower/Toilet, 10'X18', 180 sq. ft.
- Workforce Lunch Room w. sink, refrigerator, and stove, 18'X20', 360 sq. ft.
- Carpentry Shop, 28'X30', 840 sq. ft.
- Material Storage Area, 35'X60', 2,100 sq. ft. (mezzanine w/shelving, 12'X60', 720 sq. ft.)
- Hazardous Material Storage Area, 10'X12', 120 sq. ft.
- Small Equipment Storage Area, 18'X50', 900 sq. ft.
- Vehicle Storage Area, 60'X68', 4,080 sq. ft.
- Electrical Room, 10'X15', 150 sq. ft.
- Plumbing/Fire Protection Room, 10'X14', 140 sq. ft.
- Drama, 12'X20', 240 sq. ft. (allotted from Material Storage Area)

Subtotal 9,468 sq. ft.

Area Grossing Factor (10%) 947 sq. ft.

Circulation (10%) 1,041 sq. ft.

Grand Total 11,456 sq. ft.

The layout from Weston & Sampson Engineers excludes any office space. An additional 500 sq. ft. would be needed for office space, office equipment, and file room if the Director of Facilities along with his/her secretary were moved from Central Services.

I have attached copies of what the building might look like and interior layouts of the space.

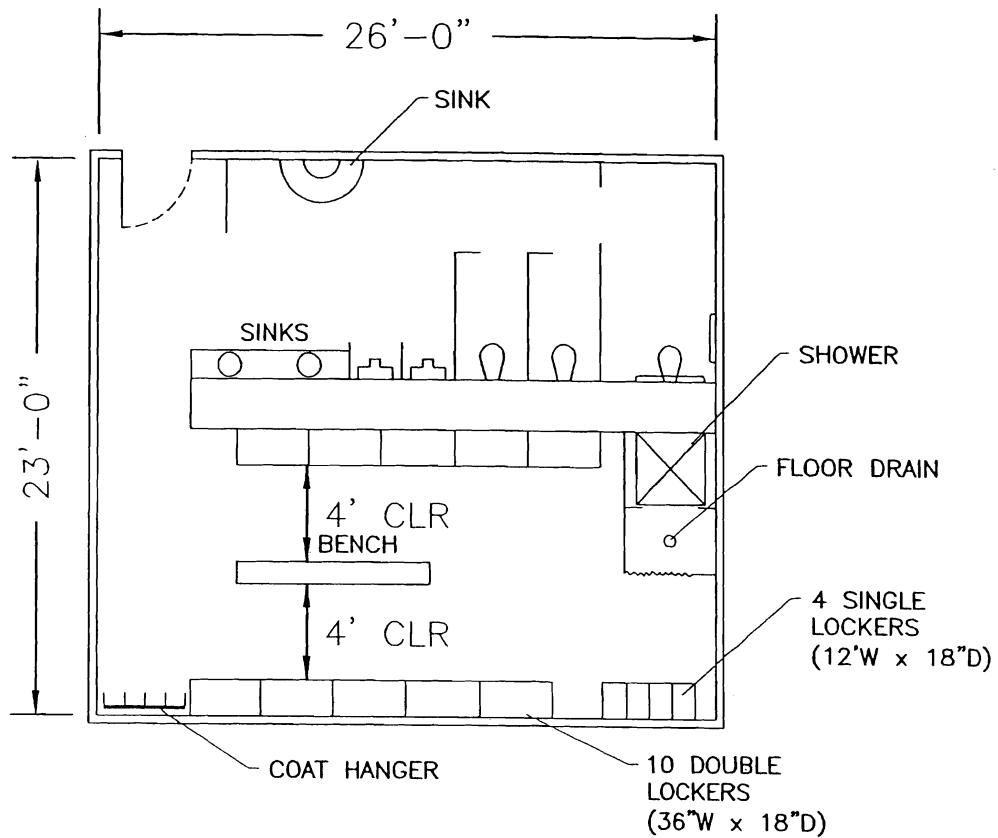

MALE LOCKER/SHOWER/TOILET
 23' x 26' = 598 SF

GRANBY, CONNECTICUT
 AUGUST 08
 BOE SPACE NEEDS ASSESSMENT

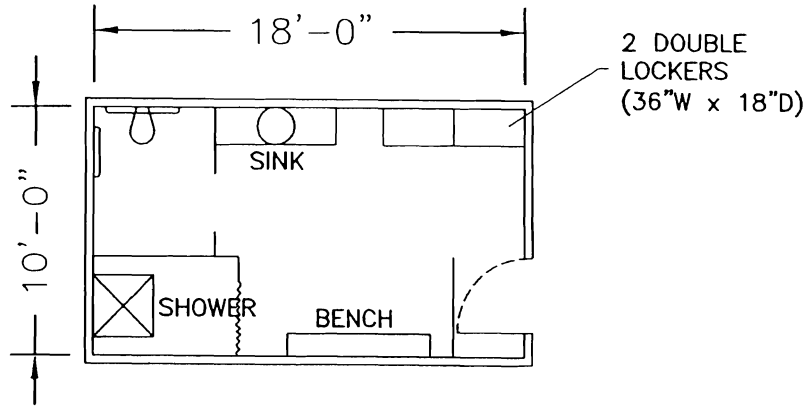

FEMALE LOCKER/SHOWER/TOILET
 10' x 18' = 180 SF

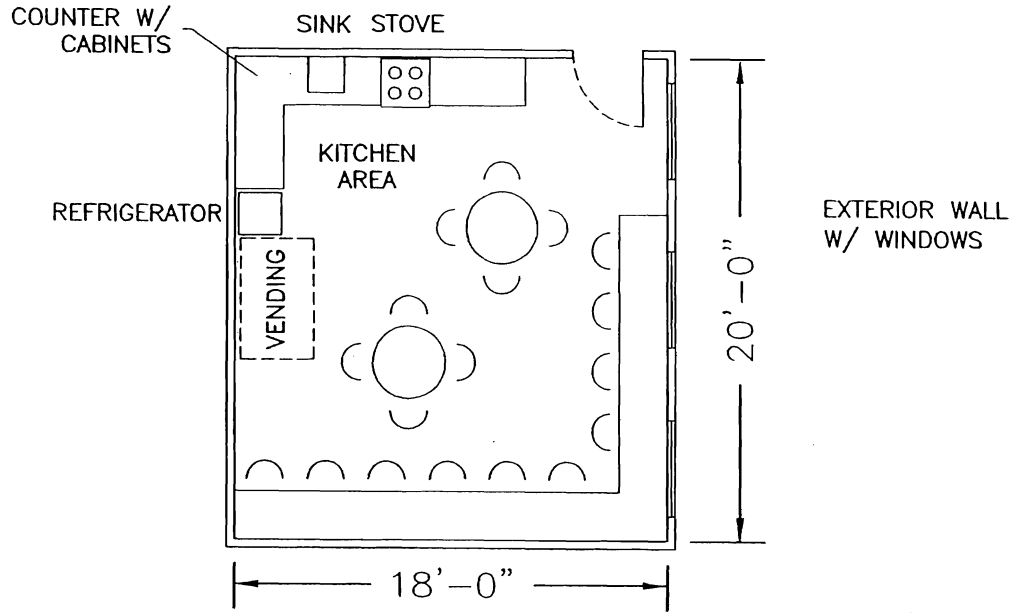

WORK FORCE LUNCH ROOM
 18' x 20' = 360 SF

GRANBY, CONNECTICUT

AUGUST 08

BOE SPACE NEEDS ASSESSMENT

Scale: 1/8" = 1'-0"

Sheet 5

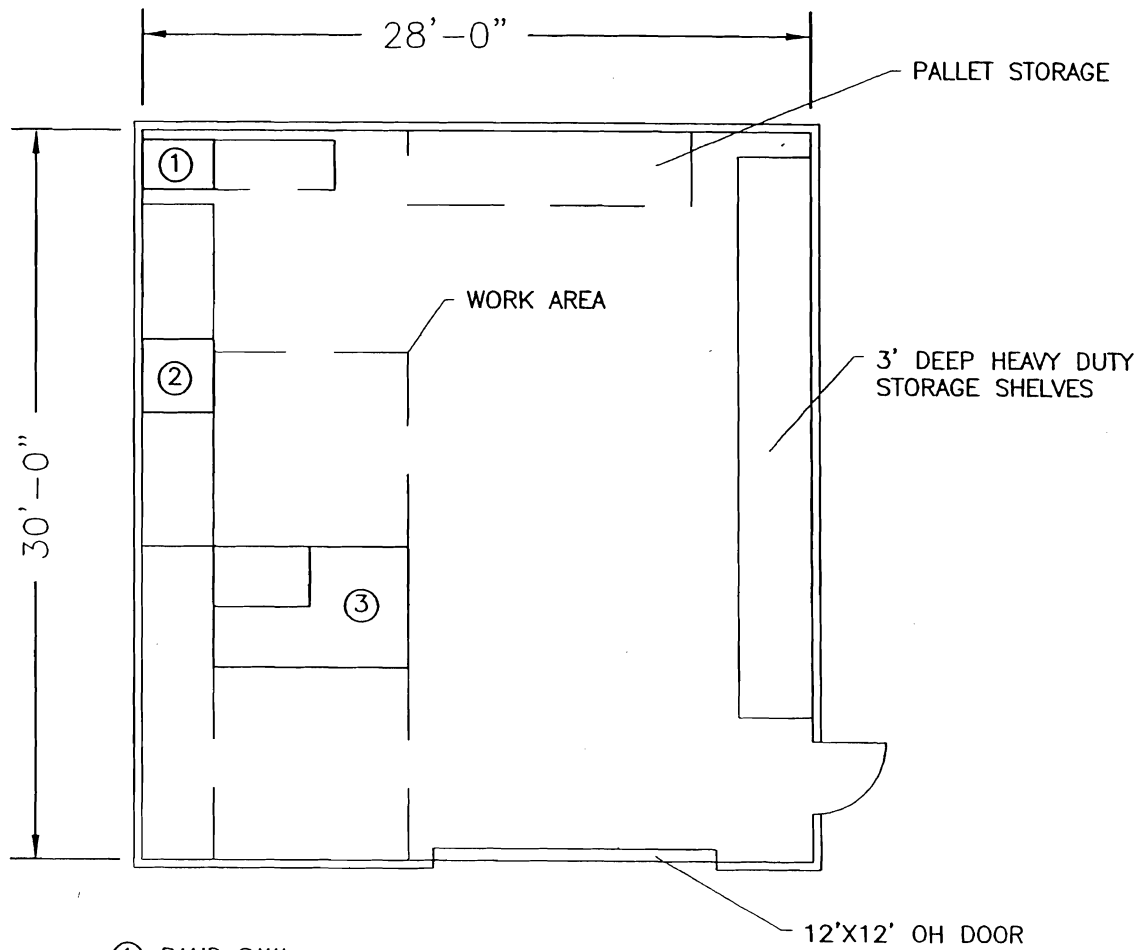

- ① BAND SAW
- ② BENCH MOUNTED CHOP SAW
- ③ TABLE SAW

CARPENTRY SHOP

28' x 30' = 840 SF

GRANBY, CONNECTICUT

AUGUST 08

BOE SPACE NEEDS ASSESSMENT

Scale: 1/8"=1'-0"

Sheet 6

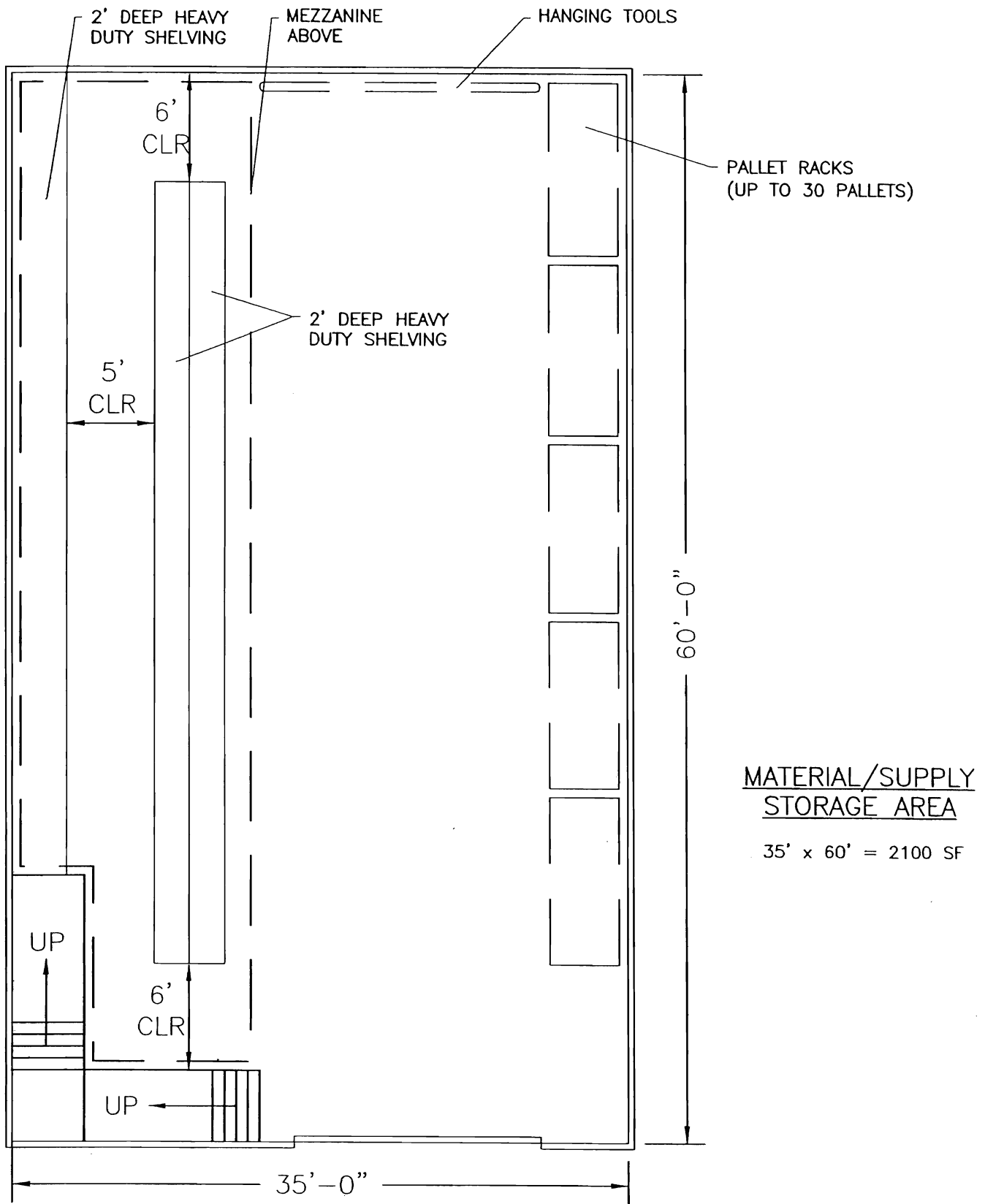

GRANBY, CONNECTICUT

AUGUST 08

BOE SPACE NEEDS ASSESSMENT

Scale: 1/8"=1'-0"

Sheet 7

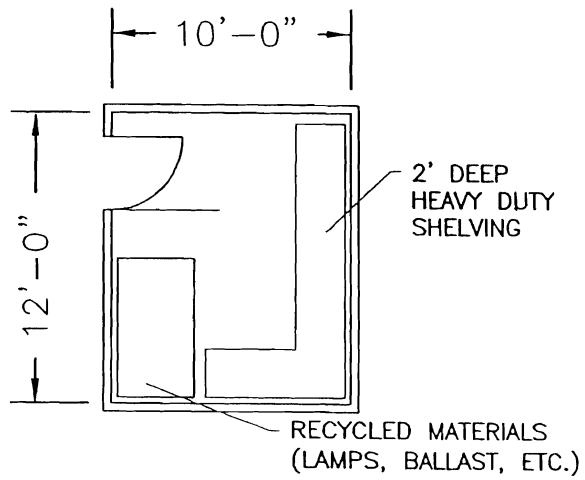

HAZARDOUS MATERIAL ROOM

10' x 12' = 120 SF

GRANBY, CONNECTICUT

AUGUST 08

BOE SPACE NEEDS ASSESSMENT

Scale: 1/8"=1'-0"

Sheet 8

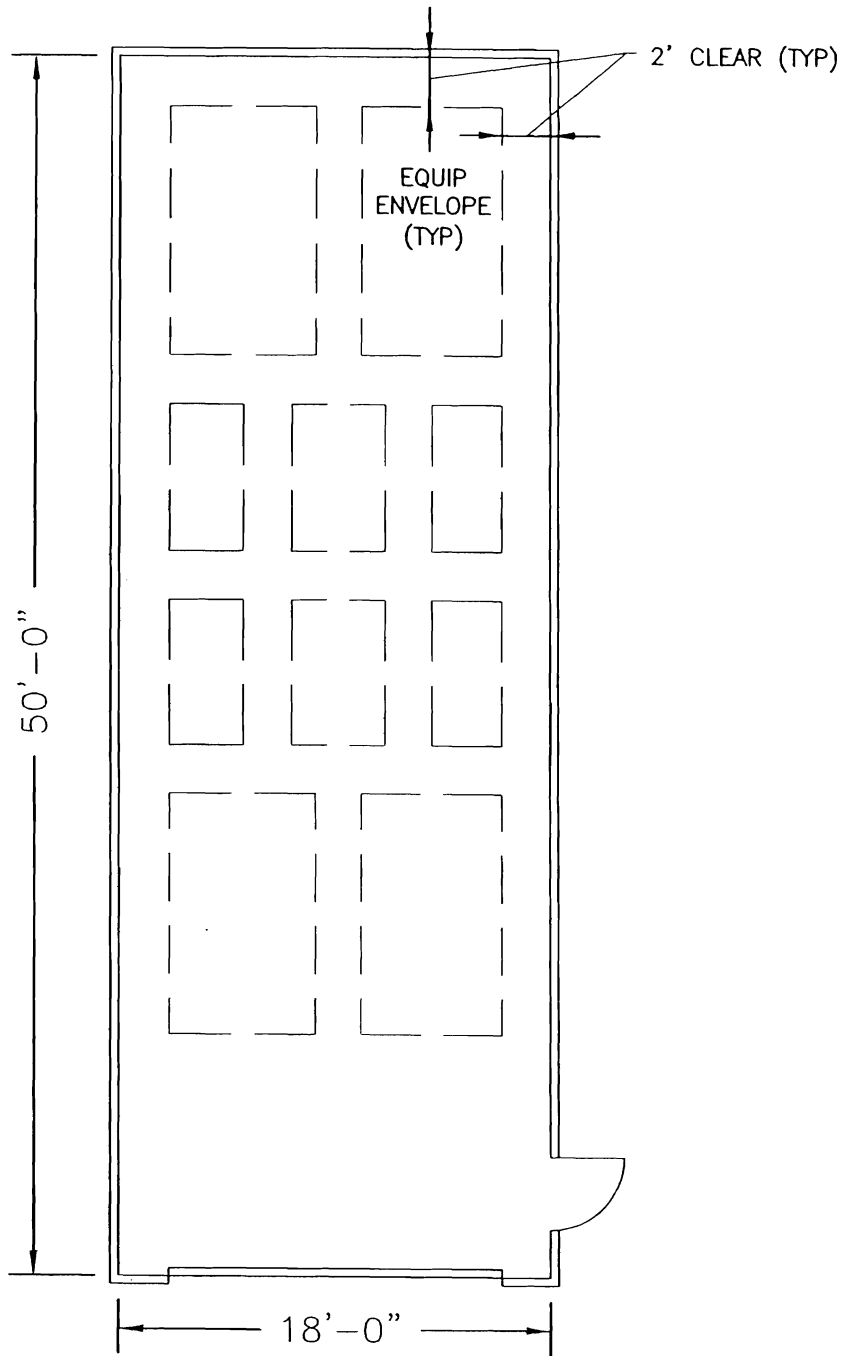

SMALL EQUIPMENT STORAGE

18' x 50' = 900 SF

GRANBY, CONNECTICUT

AUGUST 08

BOE SPACE NEEDS ASSESSMENT

Scale: 1/8"=1'-0"

Sheet 9

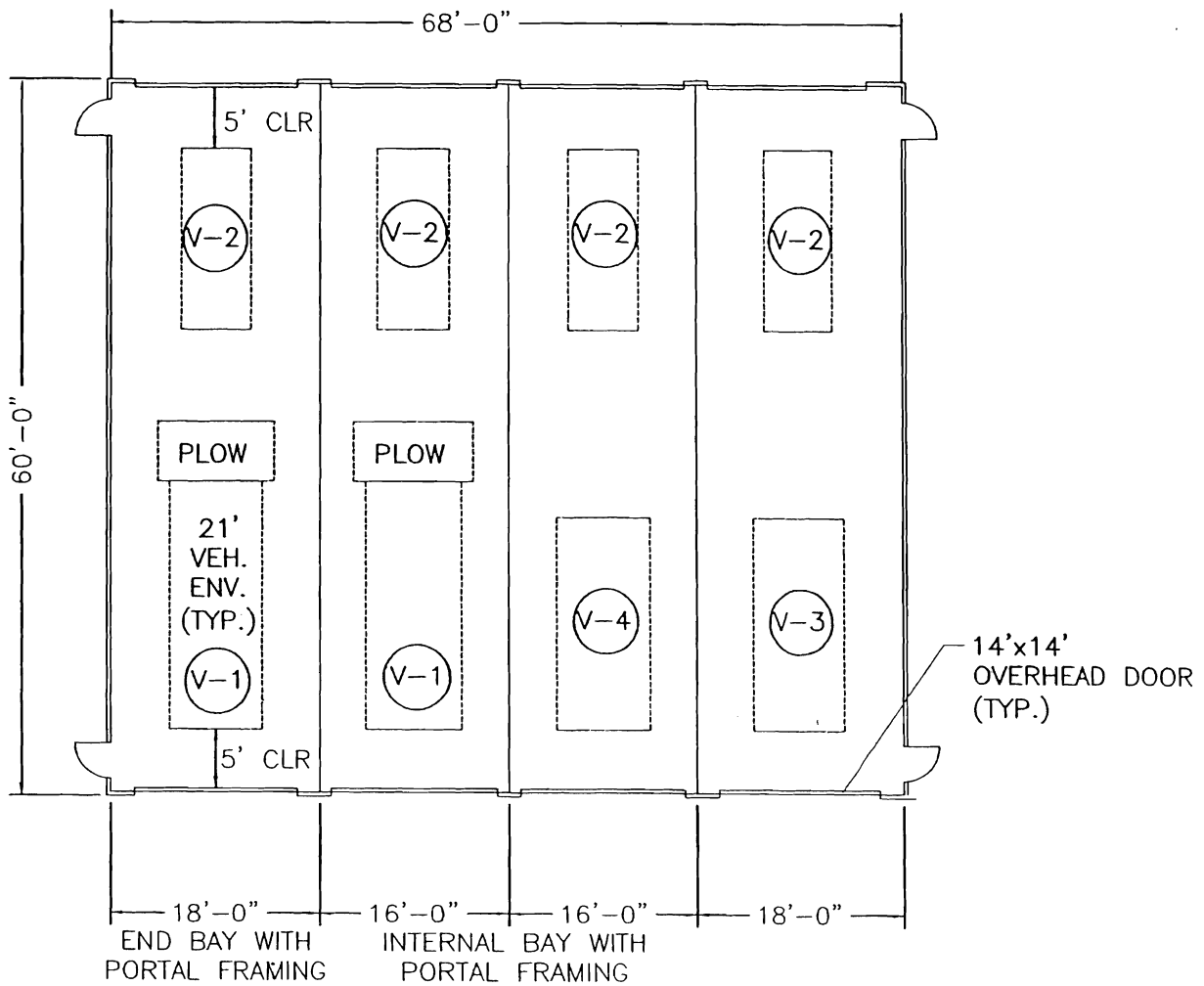

- VEHICLE LIST
- V-1 : PICKUP TRUCK WITH PLOW
 - V-2 : VAN
 - V-3 : STUDENT TRANSPORT VAN
 - V-4 : TRAILER

VEHICLE STORAGE AREA
 60' x 68' = 4080 SF

NOTE: KITCHEN VAN
 AND TECHNOLOGY VAN STORED
 OUTSIDE

GRANBY, CONNECTICUT
 AUGUST 08
 BOE SPACE NEEDS ASSESSMENT

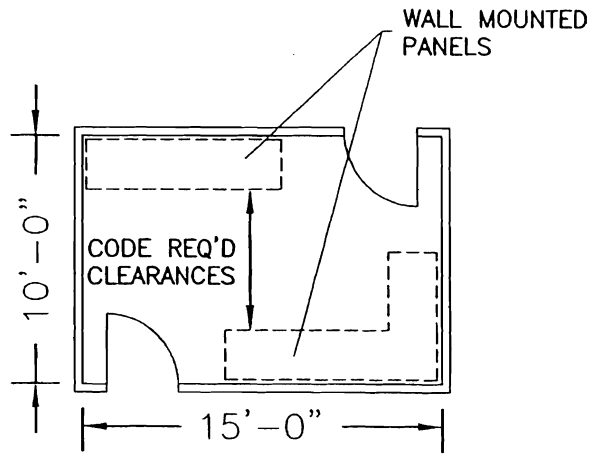

ELECTRIC ROOM
 10' x 15' = 150 SF

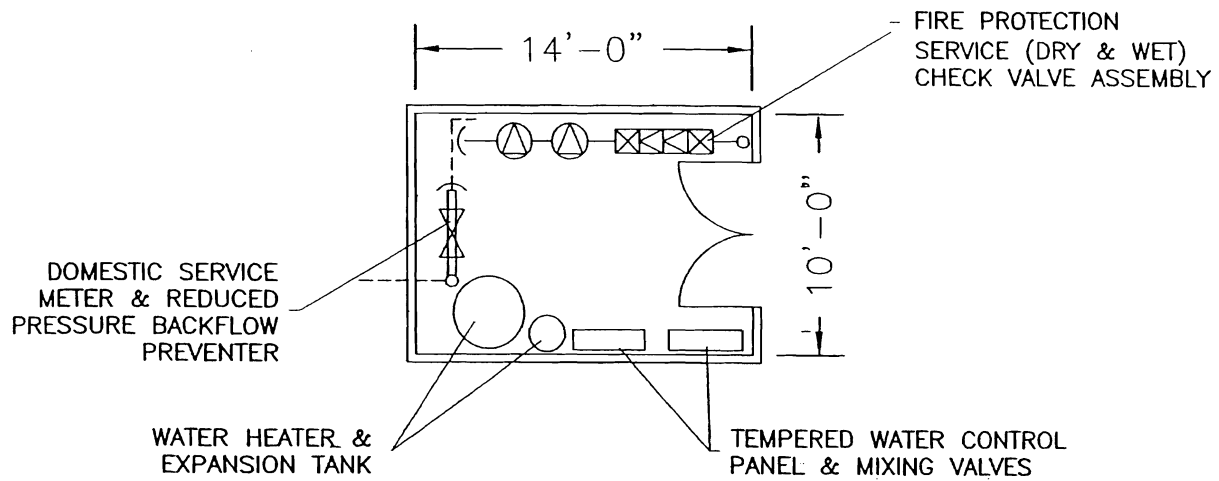

PLUMBING/FIRE PROTECTION ROOM
 10' x 14' = 140 SF

GRANBY, CONNECTICUT

AUGUST 08

BOE SPACE NEEDS ASSESSMENT

Scale: 1/16"=1'-0"

Sheet 11

Town of Granby CT
 Department of Public Works / Board of Education
Space Needs Summary
 August 2008

Building Requirements

Area	Description	Size (SF)	Sheet No.	Ref No.	Room / Area Dimensions		
					length	width	size
DPW Space Needs	Vehicle Storage Area	1,540	1	D 0.00	22	70	1,540
	Wash Bay	1,750	2	D 4.03 **	25	70	1,750
	Wash Equipment Room	360	2	D 4.03 **	18	20	360
	Small / Towed Equipment Storage	5,600	3	D 0.00	70	80	5,600
	Subtotal:	9,250					
	Area Grossing Factor (5%):	463					
	Circulation:	(included)					
	TOTAL:	9,713					
	Requested:	8,480					
BOE Space Needs	Male Locker/Shower/Toilet	598	4	B 1.09	23	26	598
	Female Locker/Shower/Toilet	180	5	B 1.11	10	18	180
	Workforce Lunch Room	360	5	B 2.07	18	20	360
	Carpentry Shop	840	6	C 1.06	28	30	840
	Material/Supply Storage Area	2,100	7	D 0.00	35	60	2,100
	Hazardous Material Storage Area	120	8	C 9.16**	10	12	120
	Small Equipment Storage Area	900	9	C 9.02**	18	50	900
	Vehicle Storage Area	4,080	10	D 2.08	60	68	4,080
	Electric Room	150	11	B 5.01	10	15	150
	Plumbing/Fire Protection Room	140	11	B 5.02	10	14	140
	Subtotal:	9,468					
	Area Grossing Factor (10%):	947					
	Circulation (10%):	1,041					
	TOTAL:	11,456					
Requested:	8,060	(plus lunchroom/restrooms/lockerspace)					

