

LAKE DALLAS INDEPENDENT SCHOOL DISTRICT
Board of Trustees



Regular Meeting
Monday, April 15, 2024 5:30 PM

Meetings of the Board are held at 104 Swisher Rd., Lake Dallas, TX 75065

The subjects to be discussed or considered or upon which any formal action may be taken are as listed below. Items do not have to be taken in the order shown on this meeting notice. Unless removed from the consent agenda, items identified within the consent agenda will be acted on at one time.

Agenda

1. **Call to Order, Roll Call, and Establishment of Quorum**
2. **Moment of Silence and Pledges of Allegiance**
3. **Student/Staff Report/Recognitions**
 - 3.A. **Student Success:** Lake Dallas ISD UIL One Act Play
 - 3.B. **Student Success:** LDHS TAFE Teach Tomorrow Summit Award
Certificates
 - 3.C. **Student Success:** LDHS Falcon Soccer Success
 - 3.D. **Student Success:** LDHS Athletic Trainer Success
 - 3.E. **Parent & Family/Community Support:** Falcon Insider Member Recognition
 - 3.F. **Faculty & Staff Engagement:** April Teachers and Employees of the Month
4. **Executive Session**

The open session of the meeting will adjourn. The Board of Trustees will reconvene in executive session pursuant to one or more of the sections of the Texas Open Meetings Act (Chapter 551 of the Texas Government Code). The Board of Trustees will reconvene in open session to take any final action, decision, or vote on a matter deliberated in executive session.

- A. Private consultation with the Board's attorney (TGC 551.071)
- B. Discussing or deliberating purchase, exchange, lease or value of real property (TGC 551.072)
- C. Discussing or deliberating negotiated contract for prospective gift or donation to the school district (TGC 551.073)

- D. Discussing or deliberating appointment, employment, evaluation, reassignments, duties, discipline, or dismissal of a public officer (TGC 551.074)
- E. Discussing or deliberating the deployment, or specific occasions for implementation of security personnel or devices; or a security audit (TGC 551.076)
- F. Discussing Security Matters regarding Emergency Operations Plans, Safety, and Security Audits (TEC 37.109)
- G. Discussing or deliberating discipline of a public school child or employee complaint against another employee (TGC 551.082)
- H. Discussing or deliberating a public school child which reveals personally identifiable information (TGC 551.0821)
- I. Investigation; exclusion of witness from a hearing during examination of another witness (TGC 551.084)
- J. Discussing economic development negotiations or offer of financial or other incentive to business prospects (TGC 551.086)

5. Public Comment

At regular Board meetings, the Board shall permit public comment, regardless of whether the topic is an item on the agenda posted with notice of the meeting. Individuals who wish to participate during the Open Comment portion of the meeting shall sign up with the presiding officer or designee before the meeting begins as specified in the Board's procedures on public comment and shall indicate the agenda item or topic on which they wish to address the Board. An individual's comments to the Board shall not exceed three minutes per meeting.

6. INFORMATION ITEMS

- 6.A. *Efficient Operations*: Board Member Continuing Education Announcement

7. CONSENT AGENDA ITEMS

Consent Agenda Items are items identified as routine, procedural, informational or self-explanatory presented as a single motion to be acted on at one time.

- 7.A. **Consideration/Approval of the Minutes of the March 18, 2024, Regular Meeting**
- 7.B. **Consideration/Approval of the Minutes of the April 1, 2024, Board Workshop Meeting**
- 7.C. **Consideration/Approval of the Monthly Financial Statements and Quarterly Investment Report**
- 7.D. **Consideration/Approval of Budget Amendment #1**
- 7.E. **Consideration/Approval of Purchases-Solution Tree Agreement**
- 7.F. **Consideration/Approval of the Curriculum Adoption of Science Materials**
- 7.G. **Consideration/Approval of Ratification of Certification of Provisions of Instructional Materials**

- 7.H. **Consideration/Approval of the 2024-2025 Professional Development Plan**
- 7.I. **Consideration/Approval of the Annual SHAC Memberships appointed by the LDISD Board of Trustees**
- 7.J. **Consideration/Approval of EIC(Local) Policy Update**
- 7.K. **Consideration/Approval of Joint Election Agreement between Lake Dallas ISD and Denton County**
- 7.L. **Consideration/Approval of Legal/Local Policy updates reflecting the Lake Dallas ISD's District of Innovation Plan**
- 7.M. **Consideration/Approval of Addendum to Communications Contract with Active Internet Technologies, dba Finalsite**
- 7.N. **Consideration/Approval of Giantex Picnic Table Bench for PreK Playground at LDE**
- 7.O. **Consideration/Approval of Putting Money Raised from PTA toward a Playground Shade at LDE.**
- 7.P. **Consideration/Approval of the Purchase of a Cafeteria Serving Line at Lake Dallas Elementary**
8. **ACTION ITEMS**
 - 8.A. ***Efficient Operations:*** Consideration/Approval of Guaranteed Maximum Price for Phase 2, part 2A of the 2019 Bond Projects at Lake Dallas High School
 - 8.B. ***Efficient Operation:*** Consideration/Approval of Chief Administrator for Safety and Security
9. **Calendar, Announcements & Information**
 - 9.A. **Upcoming Meetings & Events**
10. **Executive Session (if needed)**
11. **Adjournment**

Lake Dallas ISD UIL One Act Play Success

Presenter: Nicole Probst & Melissa Shamp

Event: LDISD Board of Trustees Meeting

Date: April 15, 2024



STUDENT SUCCESS



PARENT & FAMILY/
COMMUNITY SUPPORT



FACULTY & STAFF
ENGAGEMENT



EFFICIENT OPERATIONS



UIL One Act Play Competition

- UIL is the largest educational theatre competition
- 40 minute time limit
with 7 minutes to set-up & 7 minutes to break down
- Limited to basic UIL set and specific rules that apply to all other scenic elements
- Advancement is comparative, HS level only
- HS: 6 technicians & 11 performers rehearsed 8-14 hours a week beyond school hours for 7 weeks
- MS: 6 technicians & 7 performers rehearsed in class as well as students not traveling with us to contest



STUDENT SUCCESS



PARENT & FAMILY/
COMMUNITY SUPPORT



FACULTY & STAFF
ENGAGEMENT



EFFICIENT OPERATIONS



Middle School Clinic Day

- Prior to LDMS's contest, **all** students from the class traveled to LDHS. Theatre students from our classes helped them find costumes and props, learn technical equipment, and rehearse.



STUDENT SUCCESS



PARENT & FAMILY/
COMMUNITY SUPPORT



FACULTY & STAFF
ENGAGEMENT



EFFICIENT OPERATIONS



STUDENT SUCCESS



PARENT & FAMILY/
COMMUNITY SUPPORT



FACULTY & STAFF
ENGAGEMENT



EFFICIENT OPERATIONS



Cast of Crew

s/f The Little Prince

by Rick Cummins & John Scoullar

Aviator - Morgan Brockette

The Little Prince - Alexa DeSantis

Rose - Celeste Dittmeier

Fox - Grayson Wetherell-Bates

Businessman - Noah Kim

Lamplighter - Elizabeth Rodriguez

Stage Manager - Zoe Coleman

Technical Director - Hailey Vahl

Lighting - Kaleb Morales

Foley/Shadow Puppets -
Matthew Harrelson

Props - Emerald Gilbertson

Scenic/Projection - Aleks Ramirez

In Class Participation: Rachel Alvarez,
Lincoln Bareis, Presley Clark, Lazarus
Fisher, Sophia Gorgio, Miles Irwin, Julia
Johnson, Angel Marines



UIL Awards

All- Star Cast

Little Prince - Alexa DeSantis

Honorable Mention All- Star Cast

Rose - Celeste Dittmeier

Outstanding Technician

Stage Manager - Zoe Coleman



STUDENT SUCCESS



PARENT & FAMILY/
COMMUNITY SUPPORT



FACULTY & STAFF
ENGAGEMENT



EFFICIENT OPERATIONS





Lake Dallas High School Theatre
2024 UIL One Act Play

The Book of Dog

by Jiggs Burgess



Cast

Marvin Emma P. McConathy

Olivia Lily Dennis

Jackie Bianca Gonzalez Lougheed

Elison Emerson Melgares

Mamma Wytha K. Sarvis

Ms Edna Dylan J. R. Robbins

Ensemble

Avery Pruitt & Caleigh Quinn
Evan M. Armijo & Ryan Richey
Jordyn Camp & Savanna Kaupp

Technicians

Angelica Caron, Emmalee Clark, Hannah Davis,
Harmony Herron, Dylan J. R. Robbins, Wesley White

LAKE DALLAS
Independent School District

INSPIRE • EDUCATE • EMPOWER



STUDENT SUCCESS



PARENT & FAMILY/
COMMUNITY SUPPORT



FACULTY & STAFF
ENGAGEMENT



EFFICIENT OPERATIONS





LAKE DALLAS

Independent School District

INSPIRE • EDUCATE • EMPOWER



STUDENT SUCCESS



PARENT & FAMILY/
COMMUNITY SUPPORT



FACULTY & STAFF
ENGAGEMENT



EFFICIENT OPERATIONS





STUDENT SUCCESS



PARENT & FAMILY/
COMMUNITY SUPPORT



FACULTY & STAFF
ENGAGEMENT



EFFICIENT OPERATIONS



UIL Awards

All-Star Cast

Marvin - Emma Pauletta McConathy

All- Star Cast

Olivia - Lily Dennis

Honorable Mention All-Star Cast

Elison - Emerson Melgares

Outstanding Technician

Props - Angelica Caron



STUDENT SUCCESS



PARENT & FAMILY/
COMMUNITY SUPPORT



FACULTY & STAFF
ENGAGEMENT



EFFICIENT OPERATIONS





STUDENT SUCCESS



PARENT & FAMILY/
COMMUNITY SUPPORT



FACULTY & STAFF
ENGAGEMENT



EFFICIENT OPERATIONS



Any Questions?



LDHS TAFE Teach Tomorrow Summit Award Certificates

Presenter: Gina Minassian

Event: LDISD Board of Trustees Meeting

Date: April 15, 2024



STUDENT SUCCESS



PARENT & FAMILY/
COMMUNITY SUPPORT



FACULTY & STAFF
ENGAGEMENT



EFFICIENT OPERATIONS



TAFE Teach Tomorrow Summit

CHAPTER YEARBOOK

- Deborah Hernandez and Hannah Rogers



DIGITAL PORTFOLIO

- Quinton Tran and Lena Nguyen



STUDENT SUCCESS



PARENT & FAMILY/
COMMUNITY SUPPORT



FACULTY & STAFF
ENGAGEMENT



EFFICIENT OPERATIONS



Texas Association of Future Educators (TAFE)

PROGRAM FOCUS:

- Become college ready
- Explore teaching
- Learn new skills



STUDENT SUCCESS



PARENT & FAMILY/
COMMUNITY SUPPORT



FACULTY & STAFF
ENGAGEMENT



EFFICIENT OPERATIONS



Texas Association of Future Educators (TAFE)

PROGRAM FOCUS:

- Planning
- Managing
- Gaining hands on experience



STUDENT SUCCESS



PARENT & FAMILY/
COMMUNITY SUPPORT



FACULTY & STAFF
ENGAGEMENT



EFFICIENT OPERATIONS



Texas Association of Future Educators (TAFE)

PROGRAM FOCUS:

- Organizational skills
- Leadership skills
- Presentation skills



STUDENT SUCCESS



PARENT & FAMILY/
COMMUNITY SUPPORT



FACULTY & STAFF
ENGAGEMENT



EFFICIENT OPERATIONS



Any Questions?



STUDENT SUCCESS



PARENT & FAMILY/
COMMUNITY SUPPORT



FACULTY & STAFF
ENGAGEMENT



EFFICIENT OPERATIONS



LAKE DALLAS

Independent School District



STUDENT SUCCESS



PARENT & FAMILY/
COMMUNITY SUPPORT



FACULTY & STAFF
ENGAGEMENT



EFFICIENT OPERATIONS



FALCONS
first



LDHS Falcon Soccer Success

Presenter: Brandon Martin

Event: LDISD Board of Trustees Meeting

Date: April 15, 2024



STUDENT SUCCESS



PARENT & FAMILY/
COMMUNITY SUPPORT



FACULTY & STAFF
ENGAGEMENT



EFFICIENT OPERATIONS



Back to Back Champions

- 22/23 Season - District 7/5A Champions
 - Record - 11 wins, 2 losses, 1 tie
 - Captains - Avery Brazzell (DBU), Gabe DeSpain (Texas A&M)
 - Bi-District Champions, Area Champions, Regional ¼ Finalist
- 23/24 Season - District 7/5A Champions
 - Record - 10 wins, 2 losses, 2 ties
 - Captains - Angel Carrillo (Universal Technical Institute), Luis Romero (Howard Payne University)
 - Bi-District Champions, Area Finalist



STUDENT SUCCESS



PARENT & FAMILY/
COMMUNITY SUPPORT



FACULTY & STAFF
ENGAGEMENT



EFFICIENT OPERATIONS





Parent Volunteers

- 22/23 Season
 - Sarah Parker
 - Jimmy Hoefert
 - Christine Smarro
 - Martha Ann Parma
- 23/24 Season
 - Sarah Parker
 - Glen Denehie
 - Christine Smarro
 - Martha Ann Parma



STUDENT SUCCESS



PARENT & FAMILY/
COMMUNITY SUPPORT



FACULTY & STAFF
ENGAGEMENT



EFFICIENT OPERATIONS



Lake Dallas Coaches - We are a Team

- Assistant Coaches - Brian Cooper 22/23, Cassius Starks 23/24
- Girls Soccer - Nathan Davis and Bailey Dolezalek
- Admin - Scott Head, Scott Sander, Margaret Wilkinson, Principal Mollie Avelino and the LDHS Administrators
- Head Coaches - Jason Young, Ky Edwards, Joe Kysiak, Robert Gwinn, Ryan Howard, Sonia Foutch
- Inside Sports - Jordan Davis, Brian Miller, Kemeshia Livingston
- Training Staff – Marissa Parker and Samantha Kubicek



STUDENT SUCCESS



PARENT & FAMILY/
COMMUNITY SUPPORT



FACULTY & STAFF
ENGAGEMENT



EFFICIENT OPERATIONS



Lake Dallas High School Student Athletic Trainers

Presenter: Marissa Parker, MSEd, LAT, ATC

Event: LDISD Board of Trustees Meeting

Date: April 15, 2024



STUDENT SUCCESS



PARENT & FAMILY/
COMMUNITY SUPPORT



FACULTY & STAFF
ENGAGEMENT



EFFICIENT OPERATIONS



NTATS Student Symposium

- 31 Teams from across the metroplex
- Student competitions & conference with topics including:
 - Quiz Bowl competition
 - Ankle Taping competition
 - Injury Poster competition
 - Sports Medicine Relay
 - Cadaver lab
 - Knee assessment lab



STUDENT SUCCESS



PARENT & FAMILY/
COMMUNITY SUPPORT



FACULTY & STAFF
ENGAGEMENT



EFFICIENT OPERATIONS





NTATS RESULTS

- 1st Place Quiz Bowl



- 3rd Place Injury Poster



STUDENT SUCCESS



PARENT & FAMILY/
COMMUNITY SUPPORT



FACULTY & STAFF
ENGAGEMENT



EFFICIENT OPERATIONS





NTATS RESULTS

- Taping Competition
 - 4 Heats, 60 total participants
 - Top 2 in each heat advance to finals
 - Judged on accuracy, speed and cleanliness

- Mia Wayne, Taping Finalist



STUDENT SUCCESS



PARENT & FAMILY/
COMMUNITY SUPPORT



FACULTY & STAFF
ENGAGEMENT



EFFICIENT OPERATIONS



Texas State Athletic Trainers' Association Academic All State

Qualifications:

- Senior
- Athletic Training Student
- 92 Average or Higher in all classes
- In good standing with the school and program

Recipients:

- Rian Bartley
- Kylah Bowser
- Tommy Gladen
- Kat Hendrix
- Deborah Hernandez Reyes
- Merctus Korklison
- Braylie Thiessen



STUDENT SUCCESS



PARENT & FAMILY/
COMMUNITY SUPPORT



FACULTY & STAFF
ENGAGEMENT



EFFICIENT OPERATIONS





STUDENT SUCCESS



PARENT & FAMILY/
COMMUNITY SUPPORT



FACULTY & STAFF
ENGAGEMENT



EFFICIENT OPERATIONS

Any Questions?



LAKE DALLAS

Independent School District



STUDENT SUCCESS



PARENT & FAMILY/
COMMUNITY SUPPORT



FACULTY & STAFF
ENGAGEMENT



EFFICIENT OPERATIONS





STUDENT SUCCESS



PARENT & FAMILY/
COMMUNITY SUPPORT



FACULTY & STAFF
ENGAGEMENT



EFFICIENT OPERATIONS



Falcon Insider Member Recognition

Presenter: John Modica, Executive Director of Administrative Services

Event: LDISD Board of Trustees Meeting

Date: April 15, 2024



Falcon Insider

- Lake Dallas ISD's Falcon Insider program is a unique opportunity for parents and community members, representing all areas of our district, to experience an interactive and in-depth behind-the-scenes view of LDISD.
- Participants interacted and learned from the people who are responsible for district programs and services, and toured facilities where learning and operations take place.



STUDENT SUCCESS



PARENT & FAMILY/
COMMUNITY SUPPORT



FACULTY & STAFF
ENGAGEMENT



EFFICIENT OPERATIONS



Falcon Insider Goals

- Provide an opportunity for participants to gain knowledge about Lake Dallas ISD.
- Build relationships with parents and community members to promote and support Lake Dallas ISD's mission, priorities and goals.
- Engage parents and community members as district partners.
- Empower participants with the knowledge they gain from this experience.



STUDENT SUCCESS



PARENT & FAMILY/
COMMUNITY SUPPORT



FACULTY & STAFF
ENGAGEMENT



EFFICIENT OPERATIONS



Falcon Insider Schedule

- November 7 at Shady Shores Elementary | 9-12
 - SSE, Daycare & Administrative Services
- December 5 at Lake Dallas Middle School | 9-12
 - LDMS, Transportation, Technology & Maintenance
- January 16 at Lake Dallas High School | 9-12
 - LDHS, Career and Technical Education (CTE) & Athletics
- February 6 at Corinth Elementary | 9-12
 - CE, Curriculum & Instruction, Special Programs
- March 5 at Lake Dallas Elementary | 9-12
 - LDE, Bilingual, Business Office & Food Services



STUDENT SUCCESS



PARENT & FAMILY/
COMMUNITY SUPPORT



FACULTY & STAFF
ENGAGEMENT



EFFICIENT OPERATIONS



Falcon Insider Members

- Cindy Aughinbaugh (*Local Dignitary*)
- Trey Austin (*Parent*)
- Gregory Bartley (*Parent*)
- Dirk Bohse (*Parent*)
- Jennifer Christy (*Parent*)
- Lynn Clark (*Local Dignitary*)
- Amanda Eldred (*Parent*)
- Mary Freeman (*Resident*)
- Jeremy Haden (*Parent*)
- Nicole Haden (*Parent*)
- Robin Hedrick (*Grandparent*)
- Monica Mooring (*Parent*)
- Lisa Morales (*Parent/Substitute*)
- Callie Rivera (*Parent*)
- Randy Rives (*Local Dignitary*)
- LaTashia Sherrod (*Parent/Business Owner*)
- Julie Smith (*Parent*)
- Priscilla White (*Resident*)



STUDENT SUCCESS



PARENT & FAMILY/
COMMUNITY SUPPORT



FACULTY & STAFF
ENGAGEMENT



EFFICIENT OPERATIONS





STUDENT SUCCESS



PARENT & FAMILY/
COMMUNITY SUPPORT



FACULTY & STAFF
ENGAGEMENT



EFFICIENT OPERATIONS

Any Questions?





STUDENT SUCCESS



PARENT & FAMILY/
COMMUNITY SUPPORT



FACULTY & STAFF
ENGAGEMENT



EFFICIENT OPERATIONS

LAKE DALLAS

Independent School District



April Teachers & Employees of the Month

Presenter: Dr. Kristin N. Brown, Superintendent

Event: LDISD Board of Trustees Meeting

Date: April 15, 2024



STUDENT SUCCESS



PARENT & FAMILY/
COMMUNITY SUPPORT



FACULTY & STAFF
ENGAGEMENT



EFFICIENT OPERATIONS



Teachers and Employees of the Month

RECOGNIZED TEACHERS

- Michelle Anderson, CE
- Frances Bassham, LDE
- Bethany Townsend, SSE
- Krisanne Key, LDMS
- Ben Scott, LDHS

RECOGNIZED EMPLOYEES

- Shelly Callen, CE
- Chelsea Hankins, LDE
- Nikki Anderson, SSE
- Kelly Phariss, LDMS
- Ashleigh Nay, LDHS
- Patricia Flores, Transportation
- Brandy Ruark, Child Nutrition
- Rachel Blake-Garcia, Child Care
- Marcus Sanders, Facilities and Operations
- Heather Vonnahme, Central Office



STUDENT SUCCESS



PARENT & FAMILY/
COMMUNITY SUPPORT



FACULTY & STAFF
ENGAGEMENT



EFFICIENT OPERATIONS



LAKE DALLAS

Independent School District



STUDENT SUCCESS



PARENT & FAMILY/
COMMUNITY SUPPORT



FACULTY & STAFF
ENGAGEMENT



EFFICIENT OPERATIONS



FALCONS
first



Annual Announcement on Continuing Education of Board Members

Lake Dallas ISD

May 2023 through April 2024 - Report run on 4/10/2024

| NEW / EXPERIENCED TRUSTEES | Local District Orientation <i>(3 hours for new Trustees, within 1st 120 days)</i> | Introduction to Texas Education Code <i>(3 hours for new Trustees, within 1st 120 days)</i> | School Safety <i>(2 hour every 2 years for all trustees) (Within 1st 120 days for new trustees)</i> | Evaluating & Improving Student Outcomes <i>(3 hours every 2 years for all trustees) (Within 1st 120 days for new trustees)</i> | Post Legislative Update to TEC <i>(2 hours for experienced Trustees after each Legislative Session) (New Trustees - N/A)</i> | Child Abuse Prevention <i>((1 hour every 2 years) (Within 1st 120 days for new trustees)</i> | Team Building Session <i>(3 hours for all Trustees)</i> | Continuing Education <i>(10 hours for new trustees; 5 hours for experienced Trustees)</i> | Completed Exceeded Incomplete |
|-----------------------------------|---|---|---|--|--|--|---|---|--------------------------------------|
| Aaron Appleby (N) | Complete | Complete | Complete | Complete | N/A | Complete | Complete | 14 hrs | Exceeds |
| Alicia McKinley | N/A | N/A | Complete | Complete | Complete | Complete | Complete | 17.5 hrs | Exceeds |
| Bruce Smith | N/A | N/A | Complete | Complete | Complete | Complete | Complete | 10 hrs | Exceeds |
| Ginger Collier | N/A | N/A | Complete | Complete | Complete | Complete | Complete | 13 hrs | Exceeds |
| Lance Stacy | N/A | N/A | Complete | Complete | Complete | Complete | Complete | 9 hrs | Exceeds |
| Mark Tucker | N/A | N/A | Complete | Complete | Complete | Complete | Complete | 10.5 hrs | Exceeds |
| Scott Baird | N/A | N/A | Complete | Complete | Complete | Complete | Complete | 12.5 hrs | Exceeds |

(N) = New Trustee

School board members must complete training that is required by the State Board of Education (SBOE), and the board president must publicly announce whether each board member has met the SBOE training requirements. Board members must receive continuing education training in the areas reflected in this table, according to Tex. Educ. Code §11.159; 19 Tex. Admin. Code § 61.1, 61.3.

The annual announcement does not cover open government and cybersecurity training required for trustees under other law. Tex. Gov't Code §§ 551.005, 552.012, and 2054.5191. OMA and PIA training is required of all elected officials within 90 days of election or appointment. PIA training may be delegated by district policy. Cybersecurity training is required of all school board members annually.



This report is provided as a TASB member service. Official recordkeeping of Board Member continuing education credit is the responsibility of the district.

Framework for School Board Development

Preamble

The mission of the public education system of this state is to ensure that all Texas children have access to a quality education that enables them to achieve their potential and fully participate now and in the future in the social, economic, and educational opportunities of our state and nation (Texas Education Code, §4.001).

The board of trustees is the governing body for Texas public schools. To effectively meet the challenges of public education, school boards and superintendents must function together as a governance leadership team. Each leadership team will annually assess its development needs both as a corporate body and as individuals. As a team, they will focus on the improvement of locally developed student outcomes and provide support for opportunities and experiences through vision and goals, systems and processes, progress and accountability, advocacy and engagement, and synergy and teamwork. Teams ensure that their districts provide equitable and effective educational programs and services for all students. The Framework for School Board Development has been approved by the State Board of Education to provide the critical areas of development for all public school boards.

Framework

- I. **Vision and Goals**—The board ensures creation of a shared vision and locally developed, measurable goals that improve student outcomes and provide support for opportunities and experiences. The board:
 - Keeps the district focus on the well-being of all children
 - Adopts a shared vision that incorporates input from the community to reflect local aspirations as well as present and future needs for all children
 - Ensures that the vision aligns with the state’s mission, objectives, and goals for education established by law or rule
 - Adopts a reasonable number of specific, quantifiable, research-based, and time-bound goals that align with state law, are developed with community input, and support the vision to improve student outcomes
 - Embraces, supports, and fulfills the vision that all students receive what they need to learn, thrive, and grow, including resources, opportunities, and experiences
 - Uses the vision and goals to drive all deliberations, decisions, and actions

Framework for School Board Development

- II. **Systems and Processes**—The board ensures systems and processes are in place to accomplish the vision and goals. The board:
- Regularly develops, reviews, and adopts board policies for effective support of the district's vision and goals
 - Approves a budget that aligns with and maximizes resources to fulfill the district's vision and goals
 - Monitors multiple, measurable elements of student progress and achievement throughout the year
 - Incorporates equity when making decisions and evaluating systems and processes
 - Focuses its actions on following board operating procedures while providing oversight of the superintendent, policymaking, planning and goal setting, progress monitoring, and evaluation, while avoiding involvement in daily operations and management
 - Approves goals, policies, and programs that ensure a safe and secure learning environment
 - Ensures the equitable distribution of resources, opportunities, and experiences based on the diverse needs of students and schools
 - Adopts a planning calendar and engages in a decision-making process consistent with state law and rule to help achieve the district's vision
 - Ensures that the district's planning and decision-making process enables all segments of the community, families, and staff to meaningfully contribute to achieving the district's vision
 - Welcomes and values all people and cultures as important stakeholders in the process for student success
 - Ensures the district has a system that monitors for sound business and fiscal practices
 - Adopts policies regarding hiring, assigning, appraising, terminating, and compensating school district personnel in compliance with state laws and rules
 - Ensures the district adopts a protocol regarding the recruitment, determination of professional development needs, building of leadership capacity, and retention rates for the district's teachers
 - Fulfills the statutory duties of the local board of trustees and upholds all laws, rules, ethical procedures, and court orders pertaining to schools and school employees

Framework for School Board Development

- III. **Progress and Accountability**—The board sets clear goals, provides resources and support, evaluates goal attainment, and engages in ongoing objective feedback on progress and commitments. The board:
- Holds itself accountable to its adopted vision, goals, commitments, and operating procedures
 - Ensures progress toward achievement of district goals through systematic, timely, and comprehensive reviews of relevant reports and student data that illustrate progress toward locally developed student outcome goals
 - Ensures equity throughout the system by regularly identifying inequities, updating policies, and appropriately distributing resources
 - Differentiates among resources, intermediate measures, and outcomes, especially when focusing on student outcomes
 - Monitors and evaluates the allocation of resources in support of the district’s vision and goals and sustainability
 - Reviews the efficiency and effectiveness of district operations and use of resources in supporting the district’s vision and goals
 - Employs and annually evaluates the superintendent on the achievement of district goals, including locally developed academic goals, demonstration of educational leadership, and management of daily operations
- IV. **Advocacy and Engagement**—The board promotes the vision and engages the community in developing and fulfilling the vision. The board advocates on behalf of Texas public schoolchildren. The board:
- Demonstrates its commitment to, and advocates on behalf of, the shared vision and goals by clearly communicating them to the superintendent, staff, and community
 - Regularly reports district progress to families and the community, which could include an online dashboard for the community
 - Ensures multiple forms of two-way communication will be used to engage, empower, and connect students, families, staff, media, and community with the district
 - Builds collaborative relationships and partnerships with families and community, business, nonprofit, higher-education, education support organizations, and governmental leaders to influence and expand educational opportunities and experiences to meet the needs of students
 - Recognizes the respective roles of and provides input and feedback to the legislature, State Board of Education, and the Texas Education Agency to ensure maximum effectiveness and benefit to Texas schoolchildren
 - Promotes school board service by educating the community about the role of a school board and encouraging leadership opportunities within the community

Framework for School Board Development

- V. **Synergy and Teamwork**—The board’s duties are distinct, and the board works effectively as a collaborative unit and as a team with the superintendent to lead the district in fulfilling the vision and goals. The board:
- Recognizes its distinct role in establishing the vision and the goals, adopting policies that guide the district, setting priorities, establishing governance protocols to oversee management of the district, adopting and overseeing the annual budget, and hiring and evaluating the superintendent
 - Recognizes each individual trustee’s duty as a trustee and fiduciary for the entire district
 - Remains focused on its goals and priorities, as opposed to individual agendas separate and apart from the shared vision
 - Annually evaluates its performance as a team, with attention given to the district’s vision and goals; fulfilling the board’s duties, responsibilities, and commitments; and the board’s working relationship with the superintendent
 - Makes decisions as a whole only at properly called meetings and recognizes that individual members have no authority to take individual action in policy or district and campus administrative matters
 - Respects the right of individual members to express their viewpoints and vote their convictions and honors the decisions of the majority
 - Develops teamwork, problem-solving, and decision-making skills as a team with its superintendent
 - Understands and adheres to laws and local policies and respects the superintendent’s responsibility to manage the school district and to direct employees in district and campus matters
 - Adopts and adheres to established policies and procedures for welcoming and addressing ideas and concerns from students, families, staff, and the community
 - Establishes and follows local policies, procedures, and ethical standards governing the conduct and operations of the board
 - Understands the leadership role of the board president and adheres to local policies and procedures about the duties and responsibilities of the board officers

Minutes of Regular Board Meeting

The Board of Trustees

Lake Dallas Independent School District

A Regular Meeting of the Board of Trustees of Lake Dallas Independent School District was held Monday, March 18, 2024, beginning at 5:30 PM at 104 Swisher Rd., Lake Dallas, TX 75065.

PRESENT: President Lance Stacy, Vice President Ginger Collier, Secretary Mark Tucker, Trustees Scott Baird, Bruce Smith, Aaron Appleby and Superintendent Dr. Kristin N. Brown

Trustee, Alicia McKinley joined the meeting at 5:31:19.

1. Call to Order, Roll Call, and Establishment of Quorum – 5:30 PM

2. Moment of Silence and Pledges of Allegiance

President Lance Stacy led the moment of silence, and the pledges of allegiance were led by LDHS Student Council members.

3. Student/Staff Report/Recognitions

A. Student Success: CE Announcements Team Recognition

Jessica Bovan, CE Principal, recognized Corinth Elementary announcements team for successfully directing and producing their morning announcements.

B. Student Success: LDHS Student Council

Katelyn Kutch, LDHS Student Council Advisor, recognized LDHS Student Council members for their success and achievements at Spring Conference.

- Sweepstakes for 9th year in a row
- Scrapbook created by Historian, Amia Dhadda won in the traditional category.
- Submitted "Table Talk" that will be presented at the State Conference in April.

C. Student Success: Region 2 UIL Solo & Ensemble Success

Denise Kennedy, LDHS Director of Bands, recognized several band members for their success at the Region 2 Solo & Ensemble Contest.

- Participation in 63 solo events and 7 ensemble events throughout the 8-hour event.
- Earned 33 Superior ratings, 25 Excellent Ratings
- 18 of the Superior rated solos were certified to participate at the UIL Texas State Solo & Ensemble Contest scheduled for late May 2024
- 6 Ensembles comprised of 31 students. received Superior ratings and were certified for the Texas State Solo & Ensemble Contest.

D. Student Success: LDHS Visual Arts Scholastic Event (VASE)

Jeanette Murray, LDHS Art Teacher, recognized several students' success at the Texas Art Education Association's Region 11N Visual Art Scholastic Event. 29 students with 36 works of art competed. Every student received a Superior Rating with 3 students advancing to state.

- Adina Clemens
- Amelia Banyaga - double medal winner
- Amanda Barraza

- Sophie Cone
- Sydney Cox
- Traeh Davis
- Amia Dhadda - double medal winner
- Anna Do
- Tristan Dorrall
- Kaylee Fengler
- Cassidy Forehand
- **Rylee Garrison - State Qualifier**
- Emma Gonzales - double medal winner
- Adyson Jolley
- Tessa Knop
- Mackenzie Krailo - double medal winner
- Alexis Mabbun
- Katelyn McCurdy
- **Mya Murphy - double medal winner and State Qualifier**
- Andrea Montes
- Helene Palacio
- Ellie Parks - double medal winner
- Arianna Roberts
- Sara Tilley
- Oscar Torres
- Quinton Tran
- **Jazz True-Wilkerson - State Qualifier**
- Abryelle Valceus - double medal winner
- Katie Wilcox

E. **Student Success:** 2024 UIL Animation Success

Kylie Buter, LDHS Animation Teacher, recognized Bianka Gonzalez-Lougheed for earning Second Runner-Up in the Digital Animation 5A Category at the UIL Animation Filmmakers Contest. This is the highest placement in LDHS school history. Bianka's animation video was shown during the presentation.

F. **Student Success:** Texas Theater Scholars Award

Nicole Probst, LDHS Director of Theater & Melissa Shamp, LDHS Technical Theater Director, recognized two students from Lake Dallas High School who received the 2024 Thespian Scholar Distinction Award.

- Hannah Shamp
- Hannah Davis

G. **Faculty & Staff Engagement:** Transportation Staff Recognition

Wes Eversole, Deputy Superintendent/CFO, recognized the quick response from the Transportation staff during the January natural gas incident.

H. **Faculty & Staff Engagement:** March Teachers & Employees of the Month

Dr. Kristin N. Brown, Superintendent, recognized the 15 staff members selected as Teachers and Employees of the Month for March. A video highlighting the March Teachers and Employees of the Month was shown during Executive session.

Teachers of the Month

- Tiffany Willis, CE
- Taylore Rimling, LDE
- Michelle Keshler, SSE
- Stephanie Sloan, LDMS
- Melissa Shamp, LDHS

Employees of the Month

- Diane Martin, CE
- Suzanne Murray, LDE
- Cheryl Phillips, SSE
- Sylvia Puga, LDMS
- Stephanie Canales, LDHS
- Daysi Ormeno, Transportation
- Sherry Morris, Child Nutrition
- Kelly Cade, Childcare
- Ninibeth Hernandez, Facilities & Operations
- Jimmy Schaefer, Central Office

4. Executive Session

The open session of the meeting adjourned at 6:04 pm. The Board of Trustees moved to executive session pursuant to one or more of the sections of the Texas Open Meetings Act (Chapter 551 of the Texas Government Code).

The Board reconvened to open session at 6:34 pm.

5. Public Comment

Persons desiring to address the Board of Trustees were given the opportunity to sign up to speak.

2 individuals and 2 husband/wife pairs signed up to speak. The husband for one of the husband/wife pairs addressed the Board. However, one of the husband/wife pairs decided not to speak when called on. This was noted on the Public Comment Sign-in Sheet and initialed by Lance Stacy, Board President.

6. CONSENT AGENDA ITEMS

Consent Agenda Items are items identified as routine, procedural, informational or self-explanatory presented as a single motion to be acted on at one time.

It was MOVED by Ginger Collier and SECONDED by Aaron Appleby to approve the Consent Agenda as presented.

- A. Consideration/Approval of the Minutes of the February 26, 2024, Regular Meeting Minutes**
- B. Consideration/Approval of the Minutes of the March 4, 2024, Board Workshop Meeting Minutes**
- C. Consideration/Approval of the January 2024 Monthly Financial Statements**
- D. Consideration/Approval of DED(LOCAL)**

A review of the current practice for paid holidays for 260-day employees and some non-260-day employees revealed that the practice is not aligned with current board policy. Current DED(LOCAL) allows for the paid holidays for only 260-day employees. A revision of DED(LOCAL) was presented for review, which would align board policy with district practice of providing paid holidays for 260-day employees as well as some non-260 days employees.

- E. Consideration/Approval of Professional Contracts for 2024-2025**

Professional term and probationary contracts are presented for your consideration.

MOTION PASSED 7-0.

7. ACTION ITEMS

- A. *Efficient Operations*: Consideration/Approval of the Construction Documents for Phase 2, Part 2A at Lake Dallas High School.**

Wes Eversole, Deputy Superintendent/CFO, presented information on the Construction Documents for Phase 2, Part 2A at Lake Dallas High School.

It was MOVED by Bruce Smith and SECONDED by Scott Baird to approve the construction documents for Phase 2, part 2A at Lake Dallas High School.

MOTION PASSED 7-0.

- B. *Efficient Operations:*** Consideration/Approval of the Design and Development phase for Phase 2, Part 2B of the 2019 Bond Projects at Lake Dallas High School
Wes, Eversole, Deputy Superintendent/CFO presented information on the Design and Development phase for Phase 2, Part 2B of the 2019 Bond Projects at Lake Dallas High School.

It was MOVED by Aaron Appleby and SECONDED by Ginger Collier to approve the design and development phase for Phase 2, part 2B of the 2019 Bond Projects at Lake Dallas High School.

MOTION PASSED 7-0.

8. CALENDAR, ANNOUNCEMENT & INFORMATION

A. Upcoming Meetings & Events

A list of upcoming events occurring between board meetings was presented.

9. Executive Session (if needed)

The open session of the meeting will adjourn. The Board of Trustees will reconvene in executive session pursuant to one or more of the sections of the Texas Open Meetings Act (Chapter 551 of the Texas Government Code). The Board of Trustees will reconvene in open session to take any final action, decision, or vote on a matter deliberated in executive session.

The Board did not move to Executive Session.

10. Adjournment

The meeting was adjourned at 7:20 pm.

Lance Stacy, Board President

Mark Tucker, Board Secretary

Minutes of Board Workshop

The Board of Trustees

Lake Dallas Independent School District

A Workshop Meeting of the Board of Trustees of Lake Dallas Independent School District was held Monday, April 1, 2024, beginning at 5:30 PM at 104 Swisher Rd., Lake Dallas, TX 75065.

PRESENT: President Lance Stacy, Vice President Ginger Collier, Secretary Mark Tucker, Trustees Scott Baird, Alicia McKinley, Bruce Smith, Aaron Appleby and Superintendent Dr. Kristin N. Brown

1. Call to Order, Roll Call, and Establishment of Quorum – 5:30 PM

2. Open Forum

At special Board meetings, the Board shall permit public comment, regardless of whether the topic is an item on the agenda posted with notice of the meeting. Individuals who wish to participate during the Open Forum portion of the meeting shall sign up with the presiding officer or designee before the meeting begins as specified in the Board's procedures on public comment and shall indicate the agenda item or topic on which they wish to address the Board. An individual's comments to the Board shall not exceed five minutes per meeting.

Persons desiring to address the Board of Trustees were given the opportunity to sign up to speak. **No one signed up to speak to the Board.**

3. Information Items

A. Student Success: Curriculum & Instruction

Kelly O'Sullivan, Associate Superintendent of C&I, discussed information regarding GPA policy, the Instructional Materials Allotment (IMA) along with the adoption process, and information and process of the 24-25 Professional Development Plan.

B. Efficient Operations: Compensation Plan

Karla Landrum, Executive Director of HR, discussed the development process of the 2024-2025 Compensation Plan which will be presented for approval at the Regular Board meeting in June.

C. Efficient Operations: Daycare

Wes Eversole, Deputy Superintendent/CFO, discussed the relocation of the Daycare, pre-k tuition, staffing, and daycare cost.

D. Efficient Operations: 2024-2025 Budget Revenue

Wes Eversole, Deputy Superintendent/CFO, discussed the 2024-2025 General Fund Revenue for Lake Dallas ISD.

4. Executive Session

The Board did not go into Executive session.

5. Adjournment

The meeting was adjourned at 8:21 pm.

Lance Stacy, Board President

Mark Tucker, Board Secretary

LAKE DALLAS ISD
 COMPARISON OF REVENUE AND EXPENDITURES
 GENERAL FUND
 FEBRUARY 2024

| | Prior Month YTD | Current Month YTD | Current Budget | Balance | % |
|-------------------------------------|--------------------|----------------------|-------------------|-------------------|--------------|
| REVENUE | | | | | |
| Local Revenue | 18,231,259 | 21,529,010 | 24,312,747 | 2,783,737 | 88.6% |
| State Revenue | 8,457,530 | 8,689,013 | 16,149,965 | 7,460,952 | 53.8% |
| Federal Revenue | 8,791 | 363,621 | 974,318 | 610,697 | 37.3% |
| Total Revenue | 26,697,581 | 30,581,644 | 41,437,030 | 10,855,386 | 73.8% |
| EXPENDITURES | | | | | |
| Instruction | 9,607,271 | 11,539,880 | 23,661,150 | 12,121,270 | 48.8% |
| Inst. Res./Media Services | 216,946 | 273,953 | 635,360 | 361,407 | 43.1% |
| Curriculum Dev. & Inst. Staff Devel | 349,827 | 418,652 | 872,295 | 453,643 | 48.0% |
| Inst. Leadership | 335,574 | 407,010 | 873,189 | 466,179 | 46.6% |
| School Leadership | 901,489 | 1,080,379 | 2,232,169 | 1,151,790 | 48.4% |
| Guidance/Counseling/Evaluation | 693,104 | 825,795 | 1,475,868 | 650,073 | 56.0% |
| Social Work Services | 0 | 0 | 13,990 | 13,990 | 0.0% |
| Health Services | 150,098 | 179,130 | 364,647 | 185,517 | 49.1% |
| Pupil Transportation | 672,969 | 778,645 | 1,613,502 | 834,857 | 48.3% |
| Cocurr./Extracurr. Activities | 597,734 | 711,826 | 1,232,350 | 520,524 | 57.8% |
| Gen Administration | 703,496 | 902,548 | 1,535,500 | 632,952 | 58.8% |
| Plant Maintenance & Operations | 2,591,193 | 3,045,868 | 5,011,404 | 1,965,536 | 60.8% |
| School Monitoring Services | 112,567 | 202,809 | 600,136 | 397,327 | 33.8% |
| Data Processing Services | 621,758 | 687,926 | 1,241,509 | 553,583 | 55.4% |
| Facilities Acq. & Construction | 12,000 | 12,000 | 14,000 | 2,000 | 85.7% |
| Payment to Fiscal Agents | 0 | 0 | 4,500 | 4,500 | 0.0% |
| Payments to JJAEP Program | 0 | 0 | 4,000 | 4,000 | 0.0% |
| Other Intergovernmental Charges | 177,833 | 123,625 | 262,815 | 139,190 | 47.0% |
| Total Expenditures | 17,743,859 | 21,190,047 | 41,648,384 | 20,458,337 | 50.9% |
| Grand Revenue Totals | 26,697,581 | 30,581,644 | 41,437,030 | | |
| Grand Expenditure Totals | 17,743,859 | 21,190,047 | 41,648,384 | | |
| Grand Totals | 8,953,722 | 9,391,597 | (211,354) | | |

LAKE DALLAS ISD
 COMPARISON OF REVENUE AND EXPENDITURES
 FOOD SERVICE FUND
 FEBRUARY 2024

| | Prior Month YTD | Current Month YTD | Current Budget | Balance | % |
|---------------------------------|--------------------|----------------------|-------------------|----------------|--------------|
| REVENUE | | | | | |
| Local Revenue | 357,071 | 530,298 | 724,247 | 193,949 | 73.2% |
| State Revenue | 13,912 | 16,563 | 36,000 | 19,437 | 46.0% |
| Federal Revenue | 579,497 | 717,524 | 1,258,243 | 540,719 | 57.0% |
| Total Revenue | 950,479 | 1,264,385 | 2,018,490 | 754,105 | 62.6% |
| EXPENDITURES | | | | | |
| Food Service | 928,157 | 1,407,793 | 2,013,158 | 605,365 | 69.9% |
| Total Expenditures | 928,157 | 1,407,793 | 2,013,158 | 605,365 | 69.9% |
| Grand Revenue Totals | 950,479 | 1,264,385 | 2,018,490 | | |
| Grand Expenditure Totals | 928,157 | 1,407,793 | 2,013,158 | | |
| Grand Totals | 22,323 | (143,408) | 5,332 | | |

LAKE DALLAS ISD
 COMPARISON OF REVENUE AND EXPENDITURES
 DEBT SERVICE FUND
 FEBRUARY 2024

| | Prior Month YTD | Current Month YTD | Current Budget | Balance | % |
|---------------------------------|--------------------|----------------------|-------------------|-------------------|--------------|
| REVENUE | | | | | |
| Local Revenue | 11,863,660 | 13,991,664 | 15,900,712 | 1,909,048 | 88.0% |
| State Revenue | 1,237,404 | 1,237,404 | 291,589 | (945,815) | 424.4% |
| Total Revenue | 13,101,064 | 15,229,068 | 16,192,301 | 963,233 | 94.1% |
| EXPENDITURES | | | | | |
| Debt Services | 2,250 | 3,326,872 | 16,193,438 | 12,866,566 | 20.5% |
| Total Expenditures | 2,250 | 3,326,872 | 16,193,438 | 12,866,566 | 20.5% |
| Grand Revenue Totals | 13,101,064 | 15,229,068 | 16,192,301 | | |
| Grand Expenditure Totals | 2,250 | 3,326,872 | 16,193,438 | | |
| Grand Totals | 13,098,814 | 11,902,196 | (1,137) | | |

LAKE DALLAS ISD
BALANCE SHEET
GENERAL FUND, FOOD SERVICE AND DEBT SERVICE
AS OF FEBRUARY 29, 2024

General Fund

| | |
|--------------------------|---------------------|
| Cash & Investments | 41,348,341 |
| Receivables | 2,635,494 |
| Deferred Expenses | 22,472 |
| Total Assets | 44,006,306 |
| Current Payables | (20,537,437) |
| Accrued Expenses | (90,677) |
| Deferred Revenue | (381,176) |
| Total Liabilities | (21,009,290) |
| Reserve for Encumbrances | 704,950 |
| Undesig. Fund Balance | (22,997,016) |
| Reserve for Encumbrances | (704,950) |
| Total Equity | (22,997,016) |

Food Service

| | |
|-------------------------------|--------------------|
| Cash & Investments | 1,747,991 |
| Receivables | 138,027 |
| Total Assets | 1,886,018 |
| Current Payables | (579,938) |
| Accrued Expenses | (28,253) |
| Deferred Revenue | (99,311) |
| Total Liabilities | (707,502) |
| Reserve for Food Encumbrances | (1,329,299) |
| Undesig. Fund Balance | 145,495 |
| Reserve for Encumbrances | 5,288 |
| Total Equity | (1,178,516) |

Debt Services

| | |
|----------------------------|---------------------|
| Cash & Investments | 13,590,939 |
| Receivables | 1,262,570 |
| Total Assets | 14,853,509 |
| Current Payables | (139,943) |
| Deferred Revenue | (173,254) |
| Total Liabilities | (313,197) |
| Reserve for Long Term Debt | (2,103,774) |
| Undesig. Fund Balance | (12,436,539) |
| Total Equity | (14,540,312) |

**Lake Dallas ISD
Summary Of Tax Collections Comparison
February 2024**

| <u>Current Tax Collections</u> | <u>2023</u> | <u>2023</u> | <u>2022</u> |
|---|-------------------|-------------------|-------------------|
| Current Tax Roll Status: | \$39,130,672 | \$40,209,073 | \$37,169,279 |
| +/- Supplemental Adjustments | -555,859 | 1,831,150 | 743,325 |
| Balance Taxes Due After Adjustments | <u>38,574,813</u> | <u>42,040,223</u> | <u>37,912,604</u> |
| Current Collection Activity: | | | |
| General Operating Fund | 21,044,440 | 25,374,158 | 23,497,167 |
| Debt Service Fund | 13,890,717 | 13,455,380 | 11,745,060 |
| Total Current Collections | <u>34,935,157</u> | <u>38,829,539</u> | <u>35,242,227</u> |
| Unpaid Current Taxes Due @ End of Month | 3,639,656 | 3,210,684 | 2,670,377 |
| Collection % to Current Tax Role | 90.56% | 92.36% | 92.96% |

Delinquent Tax Collections

| | | | |
|--|-----------------|------------------|----------------|
| Prior Years Delinquent Tax Roll: | 716,402 | 696,078 | 741,793 |
| +/- Supplemental Adjustments | (27,113) | 351,865 | (112,763) |
| Balance Taxes Due After Adjustments | <u>689,290</u> | <u>1,047,943</u> | <u>629,030</u> |
| Delinquent Collection Activity: | | | |
| Less General Operating Funds Collected | -90,670 | 12,869 | 62,878 |
| Less Debt Service Collected | -48,403 | 6,600 | 29,852 |
| Total Delinquent Collections | <u>-139,073</u> | <u>19,469</u> | <u>92,730</u> |
| Unpaid Delinquent Taxes Due @ End of Month | 828,363 | 1,028,474 | 536,300 |
| Collection % to Delinquent Tax Role | -20.18% | 1.86% | 14.74% |

Penalties, Interest, Attorney Fees

| | | | |
|--|----------------|---------------|----------------|
| Penalties and Interest: | | | |
| Penalty and Interest Paid On Taxes | 108,527 | 72,663 | 106,951 |
| Amount Paid to Tax Attorney | 6,874 | 12,750 | 47,379 |
| Total Penalties, Interest, Attorney Fees | <u>115,401</u> | <u>85,412</u> | <u>154,330</u> |

Collection Summary

| | | | |
|--|-------------------|-------------------|-------------------|
| Current Taxes Collected | 34,935,157 | 38,829,539 | 35,242,227 |
| Delinquent Taxes Collected | -139,073 | 19,469 | 92,730 |
| Penalties, Interest, Attorney Fees | 115,401 | 85,412 | 154,330 |
| Total Tax Collections | <u>34,911,485</u> | <u>38,934,420</u> | <u>35,489,287</u> |
| Total Unpaid Current Taxes Due @ End of Month | 3,639,656 | 3,210,684 | 2,670,377 |
| Total Unpaid Delinquent Taxes Due @ End of Month | 828,363 | 1,028,474 | 536,300 |
| Total Taxes Outstanding | <u>4,468,019</u> | <u>4,239,159</u> | <u>3,206,677</u> |

LAKE DALLAS ISD

QUARTERLY INVESTMENT REPORT QUARTER ENDED FEBRUARY 29, 2024

| INVESTMENTS INVESTMENT | GENERAL FUND | | INTEREST AND SINKING | | ACTIVITY | | CONSTRUCTION 2008 | | CONSTRUCTION 2019 | | CONSTRUCTION 2019A | | CONSTRUCTION 2023 | |
|------------------------|--------------|-----------|----------------------|-----------|-----------|-----------|-------------------|-----------|-------------------|---------|--------------------|-----------|-------------------|------------|
| | NOV30 | FEB29 | NOV30 | FEB29 | NOV30 | FEB29 | NOV30 | FEB29 | NOV30 | FEB29 | NOV30 | FEB29 | NOV30 | FEB29 |
| TEXPOOL | 305 | 309 | 10,341 | 10,479 | 364,796 | 369,681 | 9,047 | 9,173 | 0 | 0 | 0 | 0 | 0 | 0 |
| Book Value | 305 | 309 | 10,340 | 10,479 | 364,787 | 369,672 | 9,047 | 9,173 | 0 | 0 | 0 | 0 | 0 | 0 |
| Market Value | 0 | 0 | 0 | 0 | -9 | -9 | 0 | 0 | 0 | 0 | 0 | 0 | 0 | 0 |
| Change | 0 | 0 | 0 | 0 | -9 | -9 | 0 | 0 | 0 | 0 | 0 | 0 | 0 | 0 |
| LONESTAR-GOVERNMENT | 842,237 | 318,525 | 32 | 33 | 4,479 | 4,539 | 0 | 0 | 0 | 0 | 0 | 0 | 0 | 0 |
| Book Value | 842,245 | 318,528 | 32 | 33 | 4,479 | 4,539 | 0 | 0 | 0 | 0 | 0 | 0 | 0 | 0 |
| Market Value | 9 | 3 | 0 | 0 | 0 | 0 | 0 | 0 | 0 | 0 | 0 | 0 | 0 | 0 |
| Change | 9 | 3 | 0 | 0 | 0 | 0 | 0 | 0 | 0 | 0 | 0 | 0 | 0 | 0 |
| LOGIC | 133,759 | 135,605 | 2,846 | 2,885 | 1,086 | 1,101 | 0 | 0 | 0 | 0 | 0 | 0 | 0 | 0 |
| Book Value | 133,781 | 135,628 | 2,846 | 2,886 | 1,086 | 1,101 | 0 | 0 | 0 | 0 | 0 | 0 | 0 | 0 |
| Market Value | 22 | 23 | 0 | 0 | 0 | 0 | 0 | 0 | 0 | 0 | 0 | 0 | 0 | 0 |
| Change | 22 | 23 | 0 | 0 | 0 | 0 | 0 | 0 | 0 | 0 | 0 | 0 | 0 | 0 |
| LONESTAR-CORPORATE | 117,225 | 5,372,355 | 0 | 2,286,754 | 677,997 | 687,474 | 0 | 0 | 0 | 0 | 0 | 0 | 0 | 0 |
| Book Value | 117,223 | 5,372,285 | 0 | 2,286,777 | 678,004 | 687,481 | 0 | 0 | 0 | 0 | 0 | 0 | 0 | 0 |
| Market Value | -2 | -69 | 0 | 23 | 7 | 7 | 0 | 0 | 0 | 0 | 0 | 0 | 0 | 0 |
| Change | -2 | -69 | 0 | 23 | 7 | 7 | 0 | 0 | 0 | 0 | 0 | 0 | 0 | 0 |
| WELLS FARGO-TMR | 0 | 0 | 0 | 0 | 0 | 0 | 0 | 0 | 0 | 0 | 0 | 0 | 0 | 0 |
| Book Value | 0 | 0 | 0 | 0 | 0 | 0 | 0 | 0 | 0 | 0 | 0 | 0 | 0 | 0 |
| Market Value | 0 | 0 | 0 | 0 | 0 | 0 | 0 | 0 | 0 | 0 | 0 | 0 | 0 | 0 |
| Change | 0 | 0 | 0 | 0 | 0 | 0 | 0 | 0 | 0 | 0 | 0 | 0 | 0 | 0 |
| TEXAS RANGE | 6,907,227 | 669,006 | 485,288 | 890,122 | 0 | 0 | 1,457,048 | 1,477,170 | 958,124 | 971,356 | 5,195,517 | 5,195,517 | 12,647,179 | 11,556,234 |
| Book Value | 6,907,227 | 669,006 | 485,288 | 890,122 | 0 | 0 | 1,457,048 | 1,477,170 | 958,124 | 971,356 | 5,195,517 | 5,195,517 | 12,647,179 | 11,556,234 |
| Market Value | 0 | 0 | 0 | 0 | 0 | 0 | 0 | 0 | 0 | 0 | 0 | 0 | 0 | 0 |
| Change | 0 | 0 | 0 | 0 | 0 | 0 | 0 | 0 | 0 | 0 | 0 | 0 | 0 | 0 |
| TOTAL | 8,000,763 | 6,495,799 | 498,507 | 3,190,273 | 1,048,358 | 1,062,795 | 1,466,095 | 1,486,343 | 958,124 | 971,356 | 5,898,056 | 5,898,056 | 12,647,179 | 11,556,234 |
| Book Value | 8,000,782 | 6,495,756 | 498,507 | 3,190,296 | 1,048,358 | 1,062,793 | 1,466,095 | 1,486,343 | 958,124 | 971,356 | 5,898,056 | 5,898,056 | 12,647,179 | 11,556,234 |
| Market Value | 29 | -44 | 0 | 23 | -2 | -2 | 0 | 0 | 0 | 0 | 0 | 0 | 0 | 0 |
| Change | 29 | -44 | 0 | 23 | -2 | -2 | 0 | 0 | 0 | 0 | 0 | 0 | 0 | 0 |

| POOLED INVESTMENTS | TOTAL BOOK VALUE FEB29 | % OF TOTAL INVESTMENT | MONTHLY AVERAGE YIELD | | WEIGHTED AVERAGE MATURITY | | TOTAL POOLED INVESTMENTS | | TOTAL FEB29 |
|--------------------|------------------------|-----------------------|-----------------------|-------|---------------------------|-------|--------------------------|------------|-------------|
| | | | NOV30 | FEB29 | NOV30 | FEB29 | NOV30 | FEB29 | |
| TEXPOOL | 389,642 | 2.12% | 5.33 | 5.33 | 40 | 36 | 30,517,071 | 29,956,317 | |
| LONESTAR-GOVT | 323,086 | 1.76% | 5.33 | 5.33 | 33 | 31 | 30,517,099 | 29,956,295 | |
| LOGIC | 139,591 | 0.76% | 5.46 | 5.46 | 53 | 42 | 28 | -22 | |
| LONESTAR-CORP | 8,346,583 | 45.36% | 5.52 | 5.52 | 64 | 58 | | | |
| WELLS FARGO TMR | 0 | 0.00% | - | - | - | - | | | |
| TEXAS RANGE | 9,203,170 | 50.01% | 5.59 | 5.59 | 51 | 51 | | | |
| TOTAL | 18,402,082 | 100.00% | | | | | | | |

LAKE DALLAS ISD
QUARTERLY INVESTMENT REPORT
QUARTER ENDED FEBRUARY 29, 2024
SUMMARY OF FIXED TERM INVESTMENTS

| FUND | INVESTMENT INSTRUMENT | PURCHASE DATE | INVESTED AMOUNT | STATED YIELD | MATURITY DATE | MARKET VALUE | MATURITY VALUE | MATURITY INTEREST |
|-------------------|-----------------------|---------------|-----------------|--------------|---------------|--------------|----------------|-------------------|
| | TEXAS RANGE | 12/14/2023 | 3,000,000 | 5.41% | 3/15/2024 | 3,034,145 | 3,040,353 | 40,353 |
| CLEARING FUND | TEXAS RANGE | 12/14/2023 | 3,500,000 | 5.34% | 04/11/2024 | 3,539,320 | 3,560,257 | 60,257 |
| CLEARING FUND | TEXAS RANGE | 2/7/2024 | 3,500,000 | 5.39% | 5/14/2024 | 3,511,340 | 3,549,482 | 49,482 |
| CLEARING FUND | TEXAS RANGE | 2/7/2024 | 3,500,000 | 5.31% | 6/18/2024 | 3,511,171 | 3,566,520 | 66,520 |
| CLEARING FUND | TEXAS RANGE | 2/13/2024 | 3,500,000 | 5.31% | 7/17/2024 | 3,508,125 | 3,578,199 | 78,199 |
| DEBT SERVICE | TEXAS RANGE | 2/16/2024 | 9,000,000 | 5.33% | 8/7/2024 | 9,018,349 | 9,226,743 | 226,743 |
| DEBT SERVICE | TEXAS RANGE | 8/17/2023 | 1,500,000 | 5.85% | 8/9/2024 | 1,547,232 | 1,585,832 | 85,832 |
| DEBT SERVICE | TEXAS RANGE | 12/15/2023 | 800,000 | 5.14% | 8/9/2024 | 808,651 | 826,739 | 26,739 |
| CONSTRUCTION 2023 | TEXAS RANGE | 7/24/2023 | 12,000,000 | 5.94% | 7/19/2024 | 12,430,407 | 12,703,062 | 703,062 |
| CONSTRUCTION 2023 | TEXAS RANGE | 12/15/2023 | 12,647,179 | 4.99% | 11/25/2024 | 12,779,950 | 13,243,787 | 596,608 |
| TOTAL | | | 52,947,179 | | | 53,688,689 | 54,880,976 | 1,933,797 |

| TOTAL INVESTMENTS BY FUND | GENERAL FUND | INTEREST AND SINKING ACTIVITY | CONSTRUCTION | TOTAL INVESTMENTS |
|---------------------------|--------------|-------------------------------|--------------|-------------------|
| | 6,495,799 | 3,190,273 | 1,062,785 | 18,402,082 |
| | | 7,653,216 | | |
| | | | | |

The Lake Dallas Independent School district complies with the objectives and policies adopted by the Lake Dallas School Board. The objectives and priorities of the investment policy of Lake Dallas Independent School District are as listed: To comply with the laws of the State of Texas as defined in Government Code 10 (Chapter 2256), known as the "Public Funds Investment Act". To provide for the safety of principal of all Lake Dallas ISD funds. To provide sufficient funds to meet the cash needs of the continuing operations of Lake Dallas ISD. To earn the highest possible rates of return on investments consistent with foregoing objectives and guidelines. To allow for diversification in the types, issues and maturities of investments so as to avoid incurring unreasonable and avoidable risks. To maintain the highest professional and ethical standards as custodians of the public trust.

Wes Eversole, Deputy Superintendent/CFO, District Investment Officer

4-11-24
Date

FUND FUNC OBJECT SUB OBJ ORG YEAR PROG LOC CODE CODE DESCRIPTION CURRENT BUDGET INCREASE/ (DECREASE) PROPOSED BUDGET

EXPENDITURES

| (USE WHOLE DOLLAR AMOUNTS ONLY.) | | | | | | | | | | | | |
|----------------------------------|----|------|----|-----|---|----|-----|------------------------|------|----------|----------|--|
| 199 | 61 | 6266 | 00 | 999 | 0 | 99 | 000 | Rental | 0.00 | 2,757.00 | 2,757.00 | |
| 199 | 61 | 6299 | 00 | 999 | 0 | 99 | 000 | Misc Contract Services | 0.00 | 300.00 | 300.00 | |
| 199 | 61 | 6395 | 00 | 999 | 0 | 99 | 000 | Supplies | 0.00 | 52.00 | 52.00 | |
| 199 | 61 | 6499 | 00 | 999 | 0 | 99 | 000 | Misc Fees | 0.00 | 2,519.00 | 2,519.00 | |
| | | | | | | | | | | | | |
| | | | | | | | | | | | | |
| | | | | | | | | | | | | |

TOTAL EXPENDITURES 0.00 5,628.00 5,628.00

REVENUES

| | | | | | | | | | | | |
|-----|---|------|---|---|---|---|---|----------------|------|----------|----------|
| 199 | 0 | 5744 | 0 | 0 | 0 | 0 | 0 | Gifts/Bequests | 0.00 | 2,750.00 | 2,750.00 |
| | | | | | | | | | | | |
| | | | | | | | | | | | |
| | | | | | | | | | | | |

TOTAL REVENUES 0.00 2,750.00 2,750.00

NET CHANGE TO FUND BALANCE (2,878.00)
+INCREASE/(DECREASE)

EXPLANATION:

Budget for the community breakfast

Processed by _____
 Date: _____

(ADMINISTRATIVE OFFICE USE ONLY)

 ORIGINATOR DATE

 SUPERVISOR/PRINCIPAL DATE
Anne Haehn 4-11-24
 DIRECTOR OF ACCOUNTING DATE

 SUPERINTENDENT DATE

 BOARD SECRETARY DATE

 BOARD PRESIDENT DATE

White copy to be filed in Board Book
 Yellow copy to be filed in Administration Office
 Pink copy to be retained by Supervisor

LAKE DALLAS ISD BUDGET AMENDMENT REQUEST

Number:

FUND FUNC OBJECT SUB ORG YEAR PROG LOC DESCRIPTION CURRENT INCREASE/ PROPOSED
OBJ OBJ CODE CODE BUDGET (DECREASE) BUDGET

EXPENDITURES

(USE WHOLE DOLLAR AMOUNTS ONLY.)

| | | | | | | | | | | | |
|-----|----|------|----|-----|---|----|-----|-----------------------------------|---|-----------|-----------|
| 199 | 11 | 6329 | 35 | 041 | 0 | 11 | 302 | Ed. Foundation Grant- MS | 0 | 737.00 | 737.00 |
| 199 | 11 | 6329 | 35 | 999 | 0 | 11 | 300 | Ed. Foundation Grant- CE, SSE,LDE | 0 | 13,676.00 | 13,676.00 |
| 199 | 11 | 6395 | 35 | 101 | 0 | 11 | 304 | Ed. Foundation Grant- LDE | 0 | 4,052.00 | 4,052.00 |
| 199 | 11 | 6395 | 35 | 105 | 0 | 11 | 302 | Ed. Foundation Grant- SSE | 0 | 500.00 | 500.00 |
| 199 | 11 | 6395 | 35 | 105 | 0 | 23 | 304 | Ed. Foundation Grant- SSE | 0 | 5,000.00 | 5,000.00 |
| 199 | 11 | 6395 | 35 | 105 | 0 | 11 | 305 | Ed. Foundation Grant- SSE | 0 | 5,000.00 | 5,000.00 |
| 199 | 11 | 6299 | 35 | 105 | 0 | 23 | 303 | Ed. Foundation Grant- SSE | 0 | 600.00 | 600.00 |
| 199 | 11 | 6395 | 35 | 001 | 0 | 11 | 303 | Ed. Foundation Grant- HS | 0 | 289.00 | 289.00 |
| 199 | 11 | 6329 | 35 | 041 | 0 | 11 | 306 | Ed. Foundation Grant- MS | 0 | 1,000.00 | 1,000.00 |
| 199 | 11 | 6395 | 35 | 041 | 0 | 11 | 300 | Ed. Foundation Grant- MS | 0 | 575.00 | 575.00 |
| 199 | 11 | 6395 | 35 | 105 | 0 | 11 | 301 | Ed. Foundation Grant-SSE | 0 | 1,673.00 | 1,673.00 |
| 199 | 11 | 6329 | 35 | 001 | 0 | 11 | 304 | Ed. Foundation Grant- HS | 0 | 1,898.00 | 1,898.00 |

TOTAL EXPENDITURES

| | | |
|------|-----------|-----------|
| 0.00 | 35,000.00 | 35,000.00 |
|------|-----------|-----------|

REVENUES

| | | | | | | | | | | | |
|-----|---|------|----|---|---|---|---|-------------------|---|-----------|-----------|
| 199 | 0 | 5744 | 35 | 0 | 0 | 0 | 0 | Gifts and bequest | 0 | 35,000.00 | 35,000.00 |
|-----|---|------|----|---|---|---|---|-------------------|---|-----------|-----------|

TOTAL REVENUES

| | | |
|------|-----------|-----------|
| 0.00 | 35,000.00 | 35,000.00 |
|------|-----------|-----------|

NET CHANGE TO FUND BALANCE

+INCREASE/(DECREASE)

| |
|------|
| 0.00 |
|------|

EXPLANATION:

Lake Cities Education Foundation Grant 2023-2024

| |
|--------------------|
| Processed by _____ |
| Date: _____ |

(ADMINISTRATIVE OFFICE USE ONLY)

| | |
|--|---------------------------------|
| _____ ORIGINATOR | _____ DATE |
| _____ SUPERVISOR/PRINCIPAL <i>Anne Haebler</i> | _____ DATE <i>4-11-24</i> |
| _____ DIRECTOR OF ACCOUNTING | _____ DATE |
| _____ SUPERINTENDENT | _____ DATE |
| _____ BOARD SECRETARY | _____ DATE |
| _____ BOARD PRESIDENT | _____ DATE |

White copy to be filed in Board Book
Yellow copy to be filed in Administration Office
Pink copy to be retained by Supervisor

LAKE DALLAS ISD BUDGET AMENDMENT REQUEST

Number:

| | | | | | | | | | | | |
|------|------|--------|------------|-----|------|--------------|-------------|-------------|-------------------|----------------------------------|--------------------|
| FUND | FUNC | OBJECT | SUB OBJ | ORG | YEAR | PROG CODE | LOC CODE | DESCRIPTION | CURRENT BUDGET | Org.: INCREASE/ (DECREASE) | PROPOSED BUDGET |
|------|------|--------|------------|-----|------|--------------|-------------|-------------|-------------------|----------------------------------|--------------------|

(USE WHOLE DOLLAR AMOUNTS ONLY.)

REVENUES

| | | | | | | | | | | | |
|-----|---|------|---|---|---|---|---|---------------------------|---------------|----------------|---------------|
| 199 | 0 | 5711 | 0 | 0 | 0 | 0 | 0 | Taxes Current Year | 22,916,413.00 | (1,652,636.00) | 21,263,777.00 |
| 199 | 0 | 5812 | 0 | 0 | 0 | 0 | 0 | Foundation School Program | 12,235,555.00 | 1,541,337.00 | 13,776,892.00 |
| | | | | | | | | | | | |
| | | | | | | | | | | | |

TOTAL REVENUES

| | | |
|---------------|--------------|---------------|
| 35,151,968.00 | (111,299.00) | 35,040,669.00 |
|---------------|--------------|---------------|

NET CHANGE TO FUND BALANCE

-111299.00

+INCREASE/(DECREASE)

EXPLANATION:

Changes to frozen property values made by DCAD based on the homestead exemption changes that were approved by the voters in Nov 2023.
This includes the results of the annual state tax value audit.

| |
|---------------------------------------|
| Processed by _____ Date: _____ |
|---------------------------------------|

(ADMINISTRATIVE OFFICE USE ONLY)

White copy to be filed in Board Book
Yellow copy to be filed in Administration Office
Pink copy to be retained by Supervisor

| | | | |
|---------------------|------------------------|----------------|------|
| _____ | ORIGINATOR | _____ | DATE |
| _____ | SUPERVISOR/PRINCIPAL | _____ | DATE |
| <i>Anne Haecher</i> | DIRECTOR OF ACCOUNTING | <i>4-11-24</i> | DATE |
| _____ | SUPERINTENDENT | _____ | DATE |
| _____ | BOARD SECRETARY | _____ | DATE |
| _____ | BOARD PRESIDENT | _____ | DATE |

LAKE DALLAS ISD BUDGET AMENDMENT REQUEST

Number: 1

FUND FUNC OBJECT SUB ORG YEAR PROG LOC DESCRIPTION CURRENT Org.: INCREASE/ PROPOSED
OBJ OBJ CODE CODE CODE BUDGET (DECREASE) BUDGET

EXPENDITURES

(USE WHOLE DOLLAR AMOUNTS ONLY.)

| FUND | FUNC | OBJECT | SUB OBJ | ORG | YEAR | PROG | LOC | DESCRIPTION | CURRENT BUDGET | INCREASE/ (DECREASE) | PROPOSED BUDGET |
|------|------|--------|---------|-----|------|------|-----|--------------------|----------------|----------------------|-----------------|
| 199 | 33 | 6395 | 0 | 999 | 0 | 99 | 555 | Supplies/Materials | 0.00 | 8,142.00 | 8,142.00 |
| | | | | | | | | | | | |
| | | | | | | | | | | | |
| | | | | | | | | | | | |
| | | | | | | | | | | | |
| | | | | | | | | | | | |
| | | | | | | | | | | | |
| | | | | | | | | | | | |

| | | | |
|---------------------------|------|----------|----------|
| TOTAL EXPENDITURES | 0.00 | 8,142.00 | 8,142.00 |
|---------------------------|------|----------|----------|

REVENUES

| FUND | FUNC | OBJECT | SUB OBJ | ORG | YEAR | PROG | LOC | DESCRIPTION | CURRENT BUDGET | INCREASE/ (DECREASE) | PROPOSED BUDGET |
|------|------|--------|---------|-----|------|------|-----|-------------|----------------|----------------------|-----------------|
| | | | | | | | | | | | |
| | | | | | | | | | | | |
| | | | | | | | | | | | |
| | | | | | | | | | | | |

| | | | |
|-----------------------|------|------|------|
| TOTAL REVENUES | 0.00 | 0.00 | 0.00 |
|-----------------------|------|------|------|

NET CHANGE TO FUND BALANCE
+INCREASE/(DECREASE) **(8,142.00)**

EXPLANATION:
To amend the budget to purchase 5 AEDs

Processed by _____
Date: _____
(ADMINISTRATIVE OFFICE USE ONLY)

| | |
|---|------------------------|
| _____ ORIGINATOR | _____ DATE |
| <i>Anne Haebler</i> SUPERVISOR/PRINCIPAL | _____ DATE |
| _____ DIRECTOR OF ACCOUNTING | <i>4-11-24</i> DATE |
| _____ SUPERINTENDENT | _____ DATE |
| _____ BOARD SECRETARY | _____ DATE |
| _____ BOARD PRESIDENT | _____ DATE |

White copy to be filed in Board Book
Yellow copy to be filed in Administration Office
Pink copy to be retrained by Supervisor

Solution Tree, Inc. Purchase Agreement

Effective April 3, 2024, Solution Tree, Inc. ("Solution Tree") located at 555 N. Morton St., Bloomington, IN 47404 and Lake Dallas Independent School District ("Customer") located at PO box 548, Lake Dallas, TX agree as follows:

- 1. Summary of Products and Services:** Customer will purchase the following Solution Tree products and services ("Products"). Additional Products may be added in a mutually agreed upon written Addendum.

| Products and Services | Total |
|---------------------------------|--------------------|
| Onsite Professional Development | \$13,000.00 |
| Total | \$13,000.00 |

- 2. Payment Terms:** Customer will provide Solution Tree with a purchase order made out to Solution Tree, 555 N. Morton St., Bloomington, IN 47404, for the full amount due under this Agreement upon execution of this Agreement (the "Purchase Order Due Date"). The total includes any travel, lodging, and incidental expenses incurred by Solution Tree. All payments are due net 30 days from the actual date of invoice. All past due invoices are subject to a finance charge of 1.5% monthly. Solution Tree will invoice Customer off of the purchase order based on the following schedule:

| Description | Payment | Expected Invoice Date |
|---------------------------------|-------------|-------------------------------|
| 20% Deposit (non-refundable) | \$ 0.00 | Waived |
| Onsite Professional Development | \$13,000.00 | Incrementally after each date |

- 3. Onsite Professional Development**

- 3.1. Description of Services:** Solution Tree agrees to provide a speaker, Haley James ("Associate"), to disseminate information for Customer on the topic of *Professional Learning Communities at Work®* on May 1, 2024 and May 8, 2024.
- 3.2. Presentation Materials:** Customer will reproduce any handouts and other print materials related to the services and will notify the Associate directly of any deadlines for reproduction.
- 3.3. Venue and Audio/Visual Equipment:** Customer will provide a venue, audio/video equipment, and technical support for all sessions.

4. General Terms

- 4.1. Intellectual Property:** Customer acknowledges that Solution Tree or Associate owns the copyrights to all tangible or electronic presentation materials, handouts, and/or program books used in conjunction with services performed under this Agreement and that no materials will be developed specifically for Customer. Solution Tree will retain all copyrights owned prior to entering this Agreement, and Customer may not reproduce any materials not designated reproducible without the express written permission of Solution Tree. All audio, video, and digital recording of the services by Customer is prohibited.
- 4.2. Force Majeure:** If an event beyond the parties' control makes performance impossible, illegal, or commercially impracticable (a "Force Majeure Event"), the parties will proceed as follows:
- a. If a Force Majeure Event prevents services from occurring onsite, the parties will arrange for the affected services to be delivered virtually on the scheduled dates.
 - b. If a Force Majeure Event prevents services from occurring as scheduled, the parties will use best efforts to reschedule or make substitutions for affected services or products.
 - c. If a Force Majeure Event prevents performance entirely, neither party will have any further liability to the other party for the prevented performance.
 - d. All obligations unaffected by a Force Majeure Event will remain in place.
- 4.3. Termination:** Solution Tree may terminate this Agreement if Solution Tree has not received a purchase order by the Purchase Order Due Date.
- a. **Onsite Professional Development:** If Customer cancels any Onsite Professional Development Services within 90 days of the scheduled date for any reason but Force Majeure, Customer will reimburse Solution Tree for any reasonable business expenses incurred in anticipation of performance of this Agreement that exceed the amount of the deposit. If events beyond the parties' control make performance on the scheduled dates impossible, the parties will use best efforts to reschedule the Onsite Professional Development Services.
- 4.4. Entire Agreement:** This Agreement and any exhibits attached hereto constitute the entire agreement of the parties and supersede any prior or contemporaneous written or oral understanding or agreement. No waiver or modification of any of the terms of the Agreement will be effective unless made in writing and signed by both parties, and the unenforceability, invalidity, or illegality of any provision of this Agreement will not render the other provisions unenforceable, invalid, or illegal. Any waiver by either party of any default or breach hereunder will not constitute a waiver of any provision of this Agreement or of any subsequent default or breach of the same or a different kind.

This Agreement is acknowledged and accepted by Customer and Solution Tree:

Kerri Blevins
Principal
Lake Dallas Independent School District

Date

Date

Solution Tree, Inc.



**Solution Tree, Inc.
Purchase Agreement**

Effective July 21, 2023, Solution Tree, Inc. ("Solution Tree") located at 555 N. Morton St., Bloomington, IN 47404 and Lake Dallas Independent School District - Corinth Elementary School ("Customer") located at PO Box 548 Lake Dallas, Texas 75065 agree as follows:

- 1. Summary of Products and Services:** Customer will purchase the following Solution Tree products and services ("Products"). Additional Products may be added in a mutually agreed upon written Addendum.

| Products and Services | Total |
|---------------------------------|--------------------|
| Onsite Professional Development | \$19,500.00 |
| Total | \$19,500.00 |

- 2. Payment Terms:** Customer will provide Solution Tree with a purchase order made out to Solution Tree, 555 N. Morton St., Bloomington, IN 47404, for the full amount due under this Agreement upon execution of this Agreement (the "Purchase Order Due Date"). The total includes any travel, lodging, and incidental expenses incurred by Solution Tree. All payments are due net 30 days from the actual date of invoice. All past due invoices are subject to a finance charge of 1.5% monthly. Solution Tree will invoice Customer off of the purchase order based on the following schedule:

| Description | Payment | Expected Invoice Date |
|---------------------------------|------------|-----------------------|
| 20% Deposit (non-refundable) | \$ 0.00 | Waived |
| Onsite Professional Development | \$6,500.00 | August 30, 2023 |
| Onsite Professional Development | \$6,500.00 | November 1, 2023 |
| Onsite Professional Development | \$6,500.00 | March 6, 2023 |

3. Onsite Professional Development

- 3.1. Description of Services:** Solution Tree agrees to provide a speaker, Claire Springer ("Associate"), to disseminate information for Customer on the topic of *PLC at Work*® on August 30, 2023, November 1, 2023 and March 6, 2024.
- 3.2. Presentation Materials:** Customer will reproduce any handouts and other print materials related to the services and will notify the Associate directly of any deadlines for reproduction.
- 3.3. Venue and Audio/Visual Equipment:** Customer will provide a venue, audio/video equipment, and technical support for all sessions.



Solution Tree, Inc. Purchase Agreement

Effective October 6, 2023, Solution Tree, Inc. ("Solution Tree") located at 555 N. Morton St., Bloomington, IN 47404 and Lake Dallas Independent School District ("Customer") located at 104 Swisher Rd Lake Dallas, TX 75065 agree as follows:

- 1. Summary of Products and Services:** Customer will purchase the following Solution Tree products and services ("Products"). Additional Products may be added in a mutually agreed upon written Addendum.

| Products and Services | Total |
|--------------------------|--------------------|
| Professional Development | \$52,000.00 |
| Total | \$52,000.00 |

- 2. Payment Terms:** Customer will provide Solution Tree with a purchase order made out to Solution Tree, 555 N. Morton St., Bloomington, IN 47404, for the full amount due under this Agreement upon execution of this Agreement (the "Purchase Order Due Date"). The total includes any travel, lodging, and incidental expenses incurred by Solution Tree. All payments are due net 30 days from the actual date of invoice. All past due invoices are subject to a finance charge of 1.5% monthly. Solution Tree will invoice Customer off of the purchase order based on the following schedule:

| Description | Payment | Expected Invoice Date |
|------------------------------|-------------|-------------------------------|
| 20% Deposit (non-refundable) | \$ 0.00 | Waived |
| Professional Development | \$52,000.00 | Incrementally after each date |

3. Professional Development

3.1. Description of Services: Solution Tree will provide a speaker ("Associate") to perform the professional development services described in Exhibit A.

3.2. Venue and Audio/Visual Equipment: Customer will provide a venue, audio/video equipment, and technical support for all sessions in accordance with the technology requirements described in Exhibit B. Solution Tree may terminate this Agreement if Customer's equipment is not up to the required standard by 30 days prior to the start of the services. If Customer's equipment fails during the services, Customer will still be liable for the full amount.

4. General Terms

4.1. Intellectual Property: Customer acknowledges that Solution Tree or Associate owns the copyrights to all tangible or electronic presentation materials, handouts, and/or program books used in conjunction with services performed under this Agreement and that no materials will be developed specifically for Customer. Solution Tree will retain all copyrights owned prior to entering this Agreement, and Customer may not reproduce any materials not designated reproducible without the express written permission of Solution Tree. All audio, video, and digital recording of the services by Customer is prohibited.

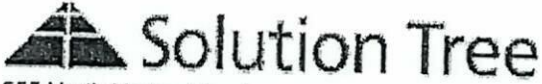

555 North Morton Street
 Bloomington IN 47404
 United States

Phone: 800-733-6786
 Fax: 812-336-7790

www.SolutionTree.com

Invoice

#S285521

9/8/2023

Bill To

Lake Dallas ISD
 PO Box 548
 Attn: Accounts Payable
 Lake Dallas TX 75065-2322
 United States

Ship To

Shady Shores Elementary
 300 Dobbs Rd
 Attn: Alice Dubroca
 Denton TX 76208
 United States

AMOUNT DUE

\$4,900.00

Due Date: 10/8/2023

| PO # | Due Date | Terms | Customer ID | Shipping Method |
|------------|-----------|--------|-------------|-----------------|
| 1050210011 | 10/8/2023 | Net 30 | 128067 | Not Applicable |

| Item | Unit Price | Quantity | Extension |
|---|------------|----------|------------|
| GPD100 Global PD for Teams - Building License | \$4,900.00 | 1 | \$4,900.00 |

Invoice reflects US funds.

Subscription date: 9/6/2023 to 9/6/2024

Upon receipt of payment, Solution Tree grants Customer a limited, non-exclusive, non-transferable license for users to access Global PD Teams via the website currently at <https://www.globalpd.com> for one year beginning on the date of the first Global PD Teams invoice. Solution Tree will invoice upon completion of Global PD Teams account setup. Customer will use Global PD Teams in compliance with the Terms of Use located at <http://globalpd.com/terms-of-use> (the "Terms of Use"), which Solution Tree reserves the right to revise from time to time.

Return Policy:

We are unable to accept returns or cancel previously placed orders for Online PD products.

To pay for this invoice via credit card, please visit payments.solutiontree.com.

Tracking Number(s):

| Subtotal | Sales Tax Total | Shipping Cost | Total | Amount Paid | Amount Due |
|------------|-----------------|---------------|------------|-------------|------------|
| \$4,900.00 | \$0.00 | \$0.00 | \$4,900.00 | \$0.00 | \$4,900.00 |



555 North Morton Street
 Bloomington IN 47404
 United States

Phone: 800-733-6786
 Fax: 812-336-7790

www.SolutionTree.com

Invoice

#S287175

10/4/2023

Bill To

Lake Dallas ISD
 PO Box 548
 Attn: Accounts Payable
 Lake Dallas TX 75065-2322
 United States

Ship To

Lake Dallas Elementary School
 401 Main St
 Lake Dallas TX 75065-2725
 United States

AMOUNT DUE

\$913.10

Due Date: 11/3/2023

| PO # | Due Date | Terms | Customer ID | Shipping Method |
|------------|-----------|--------|-------------|-----------------|
| 1010210019 | 11/3/2023 | Net 30 | 128067 | Cat Grd Comm PS |

| Item | Unit Price | Quantity | Extension |
|--|------------|----------|-----------|
| BKF746 Learning by Doing [3rd Ed] | \$47.95 | 20 | \$959.00 |
| Books Discount | (10.00%) | | \$(95.90) |

Return Policy: If for any reason you are not completely satisfied with any Solution Tree product, you may return it (in undamaged and resalable condition) within 30 days of the invoice date for a full refund or credit, less shipping and handling. Solution Tree does not pay return shipping costs. Resources that are damaged or defective upon receipt from Solution Tree must be reported and returned within 30 days for full credit. We are unable to accept returns or cancel previously placed orders for Online PD products (Global PD, Mini-Courses, and PD Playlists).

*** Please call for a return authorization number and our warehouse address prior to any return; returns without an authorization number or shipped to the wrong location will be denied and returned at the sender's expense.

Invoice reflects US funds.

To pay for this invoice via credit card, please visit payments.solutiontree.com.

Tracking Number(s): 640386458011

| Subtotal | Sales Tax Total | Shipping Cost | Total | Amount Paid | Amount Due |
|----------|-----------------|---------------|----------|-------------|------------|
| \$863.10 | \$0.00 | \$50.00 | \$913.10 | \$0.00 | \$913.10 |



Certification of Provision of Instructional Materials Survey 2024–25

Table of Contents

- Table of Contents - 2 -
- Survey Pre-Work - 4 -
 - 2024–25 Certification of Provision of Instructional Materials - 4 -
 - Instructions to Complete the Certification Process for 2024–25 - 5 -
 - Additional Supports - 5 -
 - Review Terminology - 5 -
 - About the Qualtrics Survey - 5 -
- Certification 2024–25 Survey - 6 -
 - Background Information - 6 -
 - LEA Information - 6 -
- Reading Language Arts Certification - 7 -
 - Scope and Sequence - All Grade Levels RLA - 7 -
 - English Reading Language Arts K–5 TEKS Coverage Certification - 7 -
 - English Reading Language Arts K–5 Instructional Materials - 7 -
 - Spanish Reading Language Arts K–5 TEKS Coverage Certification - 8 -
 - Spanish Reading Language Arts K–5 Instructional Materials - 8 -
 - English Reading Language Arts 6–8 TEKS Coverage Certification - 9 -
 - English Reading Language Arts 6–8 Instructional Materials - 9 -
 - English Reading Language Arts 9–12 TEKS Coverage Certification - 10 -
 - English Reading Language Arts 9–12 Instructional Materials - 10 -
- Mathematics Certification - 11 -
 - Scope and Sequence - All Grade Levels Mathematics - 11 -
 - Mathematics K–5 TEKS Coverage Certification - 11 -
 - Mathematics K–5 Instructional Materials - 12 -
 - Mathematics 6–8 TEKS Coverage Certification - 12 -
 - Mathematics 6–8 Instructional Materials - 12 -
 - Mathematics 9–12 TEKS Coverage Certification - 13 -
 - Mathematics 9–12 Instructional Materials - 13 -
- Social Studies Certification - 14 -
 - Scope and Sequence - All Grade Levels Social Studies - 14 -
 - Social Studies K–5 TEKS Coverage Certification - 14 -

| | |
|--|--------|
| Social Studies K–5 Instructional Materials | - 14 - |
| Social Studies 6–8 TEKS Coverage Certification..... | - 15 - |
| Social Studies 6–8 Instructional Materials | - 15 - |
| Social Studies 9–12 TEKS Coverage Certification | - 16 - |
| Social Studies 9–12 Instructional Materials | - 16 - |
| Science Certification | - 17 - |
| Scope and Sequence - All Grade Levels Science | - 17 - |
| Science K–5 TEKS Coverage Certification | - 17 - |
| Science K–5 Instructional Materials..... | - 18 - |
| Science 6–8 TEKS Coverage Certification | - 18 - |
| Science 6–8 Instructional Materials..... | - 18 - |
| Science 9–12 TEKS Coverage Certification | - 19 - |
| Science 9–12 Instructional Materials..... | - 19 - |
| Children’s Internet Protection Act..... | - 20 - |
| The Children's Internet Protection Act..... | - 20 - |
| Additional Informational Questions (Optional)*..... | - 21 - |
| Certification 2024-25 Survey Ratification [Printed and uploaded PDF] | - 23 - |
| Other Certified Subject Areas | - 24 - |

Survey Pre-Work

2024–25 Certification of Provision of Instructional Materials

In accordance with [Texas Education Code 31.1011](#), local educational agencies (LEAs) are required to certify annually to the State Board of Education (SBOE) and the commissioner that students have access to instructional materials covering all Texas Essential Knowledge and Skills (TEKS) for all required subjects, except physical education.

Additionally, LEAs are required to certify that they protect against access to obscene or harmful content in compliance with the requirements for certification under (i) the Children's Internet Protection Act (Pub. L. No. 106-554); (ii) Section [28.0022](#); (iii) Section [43.22](#), Penal Code; and (iv) any other law or regulation that protects students from obscene or harmful content. The TEKS Certification 2024–25 Survey includes a section to allow LEAs to certify they meet this requirement.

Like last year's process, the agency will utilize the following tools:

Certification 2024–25 Form:

Printable, hard copy of the survey to be completed offline and presented to the board of trustees or governing body for ratification and signatures.

Certification 2024–25 Survey:

Web-based application where LEAs will submit their responses collected on the TEKS Certification 2024–25 Form, and where LEAs will upload the signature page of the Form.

This year's Certification Process requires:

- The completion of the Certification 2024–25 Form;
- Ratification by the LEA's board of trustees or governing body in an open, public-noticed meeting; and
- Submission of the Certification 2024–25 Survey and upload of the ratified Certification 2024–25 Form.

TEA recommends that LEAs complete these steps by **May 1, 2024**. The Certification 2024–25 Form can be accessed at the following link on the [Instructional Materials webpage](#).

The state online instructional materials ordering system, EMAT, will close for annual maintenance on March 29, 2024, and is scheduled to reopen on May 15, 2024. **Completion of the Certification Process is required to regain access to allotment funds when EMAT reopens in May of 2024.**

Certification 2024–25 Survey submissions received after May 15, 2024, will typically be processed within five business days, then access to EMAT provided.

Instructions to Complete the Certification Process for 2024–25

1. **Review the Certification 2024–25 Form:** Print the fillable TEKS Certification 2024–25 Form found on the [Instructional Materials website](#).
2. **Gather information:** The form may require consultation with content area leads or other LEA staff.
3. **Complete Certification 2024–25 Form:** Complete the TEKS Certification 2024–25 Form by hand or digitally.
4. **Obtain needed signatures:** Ratify the **Certification 2024–25 Form** by the LEA’s board of trustees or governing body in an upcoming, open board meeting.
5. **Submit Certification 2024–25 Survey:** Complete the online Certification 2024–25 Survey by answering the questions. Inside the survey you will upload the signed Allotment and Certification 2024–25 Form from Step 4. The survey will be open for submissions beginning Monday, March 18, 2024, and will be located on the [Instructional Materials website](#).

Additional Supports

- TEA will be hosting a webinar to review the Certification 2024–25 Process on *Monday, March 18th, at 2:00 p.m. CDT*. [Registration](#) is required.
- TEA will host office hours on *Monday, March 25, at 11:00 a.m. CDT and Thursday, March 28, at 11:00 a.m. CDT*. [Registration](#) is required.
- To facilitate completion of this year’s submission, LEAs may request a copy of their previous year’s submission by submitting a [Help Desk Ticket](#).
- For questions about the Certification 2024–25 Form, Survey, or Process, please submit a [Help Desk Ticket](#).

Review Terminology

Additional Supports

- **Scope and Sequence:** A document that provides a brief outline of the standards and a recommended teaching order for a particular course/grade-level over the course of a school year.
- **Full-subject materials** (often referred to as Tier 1 or core materials): instructional material designed to, if implemented as designed, provide a student with mastery of the essential knowledge and skills for a certain subject and grade level without the need for supplementation.
- **Supplemental materials** (may be used in Tier 1, Tier 2, or Tier 3 settings): instructional material designed to assist in the instruction of one or more of the essential knowledge and skills

About the Qualtrics Survey

Within the Qualtrics survey you will be given a list of commonly known publishers and products. Should your LEA use a LEA-developed product, or the product is not listed, you will be asked to write in the name of the publisher and product.

Certification 2024–25 Survey

Background Information

QUESTION 1.0: Name of person completing this form

Barbara Pitt

QUESTION 1.1: Your email address

bpitt@ldisd.net

QUESTION 1.2:

Select the role that best describes your position at your district or charter: [Single Select]

- Instructional Materials Coordinator
- Curriculum Director
- Principal
- Administrative Assistant
- Superintendent
- Other

LEA Information

QUESTION 2.0: Region #

11

QUESTION 2.1: LEA Name and Number

Lake Dallas ISD 061912

QUESTION 2.2: Superintendent's Name

Dr. Kristin N. Brown

QUESTION 2.3: Superintendent's email address

knbrown@ldisd.net

QUESTION 2.4: School board president's or governing body's name

Lance Stacy

QUESTION 2.5: School board president's or governing body's email address

lstacy@ldisd.net

QUESTION 2.6: Date of the school board meeting at which the Certification Form was be presented and approved?

April 15,2024

Reading Language Arts Certification

Scope and Sequence - All Grade Levels RLA

QUESTION 3.0:

How is reading language arts content implemented in your LEA

Please indicate your LEA's approach to managing the implementation of reading language arts content in each of the following grade bands. [Single select for each grade band]

| | | The full-subject resources and scope and sequence are generally consistent across all classrooms | The full-subject resources being utilized are generally consistent across all classrooms, but there is variation in the scope and sequence between classrooms/campuses | The scope and sequence is generally consistent across all classrooms, but there is variation in which full-subject resources are being utilized between classrooms/campuses | Do not manage full-subject resources and scope and sequence at the LEA level | N/A |
|---------------|--------------------|--|--|---|--|--------------------------|
| QUESTION 3.1: | Grades K-2 | <input checked="" type="checkbox"/> | <input type="checkbox"/> | <input type="checkbox"/> | <input type="checkbox"/> | <input type="checkbox"/> |
| QUESTION 3.2: | Grades 3-5 | <input checked="" type="checkbox"/> | <input type="checkbox"/> | <input type="checkbox"/> | <input type="checkbox"/> | <input type="checkbox"/> |
| QUESTION 3.3: | Grades 6-8 | <input checked="" type="checkbox"/> | <input type="checkbox"/> | <input type="checkbox"/> | <input type="checkbox"/> | <input type="checkbox"/> |
| QUESTION 3.4: | Grades 9-12 | <input checked="" type="checkbox"/> | <input type="checkbox"/> | <input type="checkbox"/> | <input type="checkbox"/> | <input type="checkbox"/> |

English Reading Language Arts K-5 TEKS Coverage Certification

QUESTION 4.0:

For school year 2024-25, will your LEA provide materials to cover 100% of the **English RLA TEKS grades K-5?** (This includes teacher- or LEA-developed materials. You may select "yes" even if not all classrooms use the same materials). [Single Select]

Yes

No

English Reading Language Arts K-5 Instructional Materials

QUESTION 5.0:

Share the **full-subject and/or supplemental** publisher(s)/ product(s) that teachers in your district will use regularly (once a week or more, on average) for **English RLA grades K-5** instruction to ensure coverage of 100% of the TEKS.

Full-subject instructional materials (often referred to as Tier 1 or core materials): Instructional materials designed to, if implemented as designed, provide a student with mastery of the essential knowledge and skills for a certain subject and grade level without the need for supplementation.

Supplemental Materials (may be used in Tier 1, Tier 2, or Tier 3 settings): instructional materials designed to assist in the instruction of one or more essential knowledge and skill.

English RLA grades K–2 full-subject and/or supplemental publisher(s)/ product(s) used:

Fountas and Pinnell, UFLI Phonics, Newsela, and Handwriting Without Tears

English RLA grades 3–5 full-subject and/or supplemental publisher(s)/ product(s) used:

Fountas and Pinnell, UFLI Phonics, Newsela, and Handwriting Without Tears

Spanish Reading Language Arts K–5 TEKS Coverage Certification

QUESTION 6.0:

For school year 2024–25, will your LEA provide materials to cover 100% of the **Spanish RLA TEKS grades K–5**? (This includes teacher- or LEA-developed materials. You may select "yes" even if not all classrooms use the same materials) [Single select]

Yes

No

Spanish Reading Language Arts K–5 Instructional Materials

QUESTION 7.0:

Share the **full subject and/or supplemental** publisher(s)/ product(s) that teachers in your district will use regularly (once a week or more, on average) for **Spanish RLA grades K–5** instruction to ensure coverage of 100% of the TEKS. [Single select for each grade band]

Full-subject instructional materials (often referred to as Tier 1 or core materials): Instructional materials designed to, if implemented as designed, provide a student with mastery of the essential knowledge and skills for a certain subject and grade level without the need for supplementation.

Supplemental Materials (may be used in Tier 1, Tier 2, or Tier 3 settings): Instructional materials designed to assist in the instruction of one or more essential knowledge and skill.

Spanish RLA grades K-2 full-subject and/or supplemental publisher(s)/ product(s) used:

Fountas and Pinnell, UFLI Phonics, Newsela, and Handwriting Without Tears

Spanish RLA grades 3-5 full-subject and/or supplemental publisher(s)/ product(s) used:

Fountas and Pinnell, UFLI Phonics, Newsela, and Handwriting Without Tears

English Reading Language Arts 6-8 TEKS Coverage Certification

QUESTION 8.0:

For school year 2024-25, will your LEA provide materials to cover 100% of the **English RLA TEKS grades 6-8**? (This includes teacher- or LEA-developed materials. You may select "yes" even if not all classrooms use the same materials) [Single select]

Yes

No

English Reading Language Arts 6-8 Instructional Materials

QUESTION 9.0:

Share the **full subject and/or supplemental** publisher(s)/ product(s) that teachers in your LEA will use regularly (once a week or more, on average) for **English RLA grades 6-8** instruction to ensure coverage of 100% of the TEKS.

Full-subject instructional materials (often referred to as Tier 1 or core materials): Instructional materials designed to, if implemented as designed, provide a student with mastery of the essential knowledge and skills for a certain subject and grade level without the need for supplementation.

Supplemental Materials (may be used in Tier 1, Tier 2, or Tier 3 settings): instructional materials designed to assist in the instruction of one or more essential knowledge and skill.

English RLA grades 6–8 full-subject and/or supplemental publisher(s)/ product(s) used:

Prentice Hall Literature: Language and Literacy and Newsela

English Reading Language Arts 9–12 TEKS Coverage Certification

QUESTION 10.0:

For school year 2024–25, will your LEA provide materials to cover 100% of the **English RLA TEKS grades 9–12**? (This includes teacher- or LEA-developed materials. You may select "yes" even if not all classrooms use the same materials.)

Yes

No

English Reading Language Arts 9–12 Instructional Materials

QUESTION 11.0:

Are the **full-subject and/or supplemental** publisher(s)/ product(s) that teachers in your LEA will use regularly (once a week or more, on average) for **English RLA grades 9–12** instruction to ensure coverage of 100% of the TEKS.

Full-subject instructional materials (often referred to as Tier 1 or core materials): Instructional materials designed to, if implemented as designed, provide a student with mastery of the essential knowledge and skills for a certain subject and grade level without the need for supplementation.

Supplemental Materials (may be used in Tier 1, Tier 2, or Tier 3 settings): instructional materials designed to assist in the instruction of one or more essential knowledge and skill.

English RLA grades 9–12 full-subject and/or supplemental publisher(s)/ product(s) used:

Savvas Easy Bridge and my Perspectives and Newsela

Mathematics Certification

Scope and Sequence - All Grade Levels Mathematics

QUESTION 12.0:

How is mathematics content implemented in your LEA?

Please indicate your LEA's approach to managing the implementation of mathematics content in each of the following grade band. [Single select for each grade band]

| | | The full-subject resources and scope and sequence are generally consistent across all classrooms | The full-subject resources being utilized are generally consistent across all classrooms, but there is variation in the scope and sequence between classrooms/campuses | The scope and sequence is generally consistent across all classrooms, but there is variation in which full-subject resources are being utilized between classrooms/campuses | Do not manage full-subject resources and scope and sequence at the LEA level | N/A |
|---------------|--------------------|--|--|---|--|--------------------------|
| QUESTION 3.1: | Grades K-2 | <input checked="" type="checkbox"/> | <input type="checkbox"/> | <input type="checkbox"/> | <input type="checkbox"/> | <input type="checkbox"/> |
| QUESTION 3.2: | Grades 3-5 | <input checked="" type="checkbox"/> | <input type="checkbox"/> | <input type="checkbox"/> | <input type="checkbox"/> | <input type="checkbox"/> |
| QUESTION 3.3: | Grades 6-8 | <input checked="" type="checkbox"/> | <input type="checkbox"/> | <input type="checkbox"/> | <input type="checkbox"/> | <input type="checkbox"/> |
| QUESTION 3.4: | Grades 9-12 | <input checked="" type="checkbox"/> | <input type="checkbox"/> | <input type="checkbox"/> | <input type="checkbox"/> | <input type="checkbox"/> |

Mathematics K-5 TEKS Coverage Certification

QUESTION 13.0:

For school year 2024-25, will your LEA provide materials to cover 100% of the **mathematics TEKS grades K-5**? (This includes teacher- or LEA-developed materials. You may select "yes" even if not all classrooms use the same materials). [Single Select]

Yes

No

Mathematics K–5 Instructional Materials

QUESTION 14.0:

Share the **full-subject and/or supplemental** publisher(s)/ product(s) that teachers in your LEA will use regularly (once a week or more, on average) for **mathematics grades K–5** instruction to ensure coverage of 100% of the TEKS.

Full-subject instructional materials (often referred to as Tier 1 or core materials): Instructional materials designed to, if implemented as designed, provide a student with mastery of the essential knowledge and skills for a certain subject and grade level without the need for supplementation.

Supplemental Materials (may be used in Tier 1, Tier 2, or Tier 3 settings): instructional materials designed to assist in the instruction of one or more essential knowledge and skill.

Mathematics grades K–5 full-subject and/or supplemental publisher(s)/ product(s) used:

STEMscopes Math and Go Math!

Mathematics 6–8 TEKS Coverage Certification

QUESTION 15.0

For school year 2024–25, will your LEA provide materials to cover 100% of the **mathematics TEKS grades 6–8**? (This includes teacher- or LEA-developed materials. You may select “yes” even if not all classrooms use the same materials). [Single Select]

Yes

No

Mathematics 6–8 Instructional Materials

QUESTION 16.0:

Share the **full-subject and/or supplemental** publisher(s)/ product(s) that teachers in your LEA or charter will regularly use (once a week or more, on average) for **mathematics grades 6–8** instruction to ensure coverage of 100% of the TEKS.

Full-subject instructional materials (often referred to as Tier 1 or core materials): Instructional materials designed to, if implemented as designed, provide a student with mastery of the essential knowledge and skills for a certain subject and grade level without the need for supplementation.

Supplemental Materials (may be used in Tier 1, Tier 2, or Tier 3 settings): instructional materials designed to assist in the instruction of one or more essential knowledge and skill.

Mathematics grades 6–8 full-subject and/or supplemental publisher(s)/ product(s) used:

STEMscopes, Delta Math, Go Math!, and Maneuvering the Middle

Mathematics 9–12 TEKS Coverage Certification

QUESTION 17.0:

For School Year 2024–25, will your LEA provide materials to cover 100% of the **mathematics TEKS grades 9–12?** (This includes teacher- or LEA-developed materials. You may select "yes" even if not all classrooms use the same materials). [Single Select]

Yes

No

Mathematics 9–12 Instructional Materials

QUESTION 18.0:

Share the **full-subject and/or supplemental** publisher(s)/ product(s) that teachers in your LEA or charter will regularly use (once a week or more, on average) for **mathematics grades 9–12** instruction to ensure coverage of 100% of the TEKS.

Full-subject instructional materials (often referred to as Tier 1 or core materials): Instructional materials designed to, if implemented as designed, provide a student with mastery of the essential knowledge and skills for a certain subject and grade level without the need for supplementation.

Supplemental Materials (may be used in Tier 1, Tier 2, or Tier 3 settings): instructional materials designed to assist in the instruction of one or more essential knowledge and skill.

Mathematics grades 9–12 full-subject and/or supplemental publisher(s)/ product(s) used:

Delta Math, HMH Math, Carnegie Learning: Texas Math Solution, and Big Ideas Math

Social Studies Certification

Scope and Sequence - All Grade Levels Social Studies

QUESTION 19.0:

How is social studies content implemented in your LEA?

Please indicate your LEA's approach to managing the implementation of social studies content in each of the following grade band. [Single select for each grade band]

| | | The full-subject resources and scope and sequence are generally consistent across all classrooms | The full-subject resources being utilized are generally consistent across all classrooms, but there is variation in the scope and sequence between classrooms/campuses | The scope and sequence is generally consistent across all classrooms, but there is variation in which full-subject resources are being utilized between classrooms/campuses | Do not manage full-subject resources and scope and sequence at the LEA level | N/A |
|---------------|--------------------|--|--|---|--|--------------------------|
| QUESTION 3.1: | Grades K-2 | <input checked="" type="checkbox"/> | <input type="checkbox"/> | <input type="checkbox"/> | <input type="checkbox"/> | <input type="checkbox"/> |
| QUESTION 3.2: | Grades 3-5 | <input checked="" type="checkbox"/> | <input type="checkbox"/> | <input type="checkbox"/> | <input type="checkbox"/> | <input type="checkbox"/> |
| QUESTION 3.3: | Grades 6-8 | <input checked="" type="checkbox"/> | <input type="checkbox"/> | <input type="checkbox"/> | <input type="checkbox"/> | <input type="checkbox"/> |
| QUESTION 3.4: | Grades 9-12 | <input checked="" type="checkbox"/> | <input type="checkbox"/> | <input type="checkbox"/> | <input type="checkbox"/> | <input type="checkbox"/> |

Social Studies K-5 TEKS Coverage Certification

QUESTION 20.0:

For school year 2024-25, will your LEA provide materials to cover 100% of the **social studies TEKS grades K-5**? (This includes teacher- or LEA-developed materials. You may select "yes" even if not all classrooms use the same materials)

Yes

No

Social Studies K-5 Instructional Materials

QUESTION 21.0:

Share the **full-subject and/or supplemental** publisher(s)/ product(s) that teachers in your LEA or charter will regularly use (once a week or more, on average) for **social studies grades K-5** instruction to ensure coverage of 100% of the TEKS.

Full-subject instructional materials (often referred to as Tier 1 or core materials): Instructional materials designed to, if implemented as designed, provide a student with mastery of the essential knowledge and skills for a certain subject and grade level without the need for supplementation.

Supplemental Materials (may be used in Tier 1, Tier 2, or Tier 3 settings): instructional materials designed to assist in the instruction of one or more essential knowledge and skill.

Social Studies grades K-5 full-subject and/or supplemental publisher(s)/ product(s) used:

| |
|-----------------------|
| <i>Studies Weekly</i> |
|-----------------------|

Social Studies 6–8 TEKS Coverage Certification

QUESTION 22.0:

For school year 2024–25, will your LEA provide materials to cover 100% of the **social studies TEKS grades 6–8**? (This includes teacher- or LEA-developed materials. You may select "yes" even if not all classrooms use the same materials)

Yes

No

Social Studies 6–8 Instructional Materials

QUESTION 23.0:

Select **full-subject and/or supplemental** publisher(s)/ product(s) that teachers in your LEA or charter will regularly use (once a week or more, on average) for **social studies grades 6–8** instruction to ensure coverage of 100% of the TEKS.

Full-subject instructional materials (often referred to as Tier 1 or core materials): Instructional materials designed to, if implemented as designed, provide a student with mastery of the essential knowledge and skills for a certain subject and grade level without the need for supplementation.

Supplemental Materials (may be used in Tier 1, Tier 2, or Tier 3 settings): instructional materials designed to assist in the instruction of one or more essential knowledge and skill.

Social Studies grades 6–8 full-subject and/or supplemental publisher(s)/ product(s) used:

My HMH Social Studies

Social Studies 9–12 TEKS Coverage Certification

QUESTION 24.0:

For school year 2024–25, will your LEA provide materials to cover 100% of the **social studies TEKS grades 9–12**? (This includes teacher- or LEA-developed materials. You may select “yes” even if not all classrooms use the same materials)

Yes

No

Social Studies 9–12 Instructional Materials

QUESTION 25.0:

Share the **full-subject and/or supplemental** publisher(s)/ product(s) that teachers in your LEA or charter will regularly use (once a week or more, on average) for **social studies grades 9–12** instruction to ensure coverage of 100% of the TEKS.

Full-subject instructional materials (often referred to as Tier 1 or core materials): Instructional materials designed to, if implemented as designed, provide a student with mastery of the essential knowledge and skills for a certain subject and grade level without the need for supplementation.

Supplemental Materials (may be used in Tier 1, Tier 2, or Tier 3 settings): instructional materials designed to assist in the instruction of one or more essential knowledge and skill.

Social Studies grades 9–12 full-subject and/or supplemental publisher(s)/ product(s) used:

My HMH Social Studies

Science Certification

Scope and Sequence - All Grade Levels Science

QUESTION 26.0:

How is science content implemented in your LEA?

Please indicate your LEA's approach to managing the implementation of science content in each of the following grade bands. [Single select for each grade band]

| | | The full-subject resources and scope and sequence are generally consistent across all classrooms | The full-subject resources being utilized are generally consistent across all classrooms, but there is variation in the scope and sequence between classrooms/campuses | The scope and sequence is generally consistent across all classrooms, but there is variation in which full-subject resources are being utilized between classrooms/campuses | Do not manage full-subject resources and scope and sequence at the LEA level | N/A |
|---------------|--------------------|--|--|---|--|--------------------------|
| QUESTION 3.1: | Grades K-2 | <input checked="" type="checkbox"/> | <input type="checkbox"/> | <input type="checkbox"/> | <input type="checkbox"/> | <input type="checkbox"/> |
| QUESTION 3.2: | Grades 3-5 | <input checked="" type="checkbox"/> | <input type="checkbox"/> | <input type="checkbox"/> | <input type="checkbox"/> | <input type="checkbox"/> |
| QUESTION 3.3: | Grades 6-8 | <input checked="" type="checkbox"/> | <input type="checkbox"/> | <input type="checkbox"/> | <input type="checkbox"/> | <input type="checkbox"/> |
| QUESTION 3.4: | Grades 9-12 | <input checked="" type="checkbox"/> | <input type="checkbox"/> | <input type="checkbox"/> | <input type="checkbox"/> | <input type="checkbox"/> |

Science K-5 TEKS Coverage Certification

QUESTION 27.0:

For school year 2024-25, will your LEA provide materials to cover 100% of the **science TEKS grades K-5**? (This includes teacher- or LEA-developed materials. You may select "yes" even if not all classrooms use the same materials)

Yes

No

Science K–5 Instructional Materials

QUESTION 28.0:

Share the **full-subject and/or supplemental** publisher(s)/ product(s) that teachers in your LEA or charter will regularly use (once a week or more, on average) for **science grades K–5** instruction to ensure coverage of 100% of the TEKS.

Full-subject instructional materials (often referred to as Tier 1 or core materials): Instructional materials designed to, if implemented as designed, provide a student with mastery of the essential knowledge and skills for a certain subject and grade level without the need for supplementation.

Supplemental Materials (may be used in Tier 1, Tier 2, or Tier 3 settings): instructional materials designed to assist in the instruction of one or more essential knowledge and skill.

Science grades K–5 full-subject and/or supplemental publisher(s)/ product(s) used:

HMH Science

Science 6–8 TEKS Coverage Certification

QUESTION 29.0:

For school year 2024–25, will your LEA provide materials to cover 100% of the **science TEKS grades 6–8**? (This includes teacher- or LEA-developed materials. You may select "yes" even if not all classrooms use the same materials)

Yes

No

Science 6–8 Instructional Materials

QUESTION 30.0:

Share the **full-subject and/or supplemental** publisher(s)/ product(s) that teachers in your LEA or charter will regularly use (once a week or more, on average) for **science grades 6–8** instruction to ensure coverage of 100% of the TEKS.

Full-subject instructional materials (often referred to as Tier 1 or core materials): Instructional materials designed to, if implemented as designed, provide a student with mastery of the essential knowledge and skills for a certain subject and grade level without the need for supplementation.

Supplemental Materials (may be used in Tier 1, Tier 2, or Tier 3 settings): instructional materials designed to assist in the instruction of one or more essential knowledge and skill.

Science grades 6–8 full-subject and/or supplemental publisher(s)/ product(s) used:

HMH Science

Science 9–12 TEKS Coverage Certification

QUESTION 31.0:

For school year 2024–25, will your LEA provide materials to cover 100% of the **science TEKS grades 9–12**? (This includes teacher- or LEA-developed materials. You may select "yes" even if not all classrooms use the same materials)

Yes

No

Science 9–12 Instructional Materials

QUESTION 32.0:

Share the **full-subject and/or supplemental** publisher(s)/ product(s) that teachers in your district or charter will regularly use (once a week or more, on average) for **science grades 9–12** instruction to ensure coverage of 100% of the TEKS.

Full-subject instructional materials (often referred to as Tier 1 or core materials): Instructional materials designed to, if implemented as designed, provide a student with mastery of the essential knowledge and skills for a certain subject and grade level without the need for supplementation.

Supplemental Materials (may be used in Tier 1, Tier 2, or Tier 3 settings): instructional materials designed to assist in the instruction of one or more essential knowledge and skill.

Science grades 9–12 full-subject and/or supplemental publisher(s)/ product(s) used:

McGraw Hill and Cengage

Children's Internet Protection Act

The Children's Internet Protection Act

The Children's internet protection Act (CIPA) was enacted by Congress in 2000 to address concerns about children's access to obscene or harmful content over the Internet. (You may find more information on the FCC website.)

In accordance with Texas Administrative Code 19 TAC §66.105, school districts or charter schools are required to certify that they protect against access to obscene or harmful content in compliance with the requirements for certification under the Children's Internet Protection Act, 47 USC §254(h)(5)(B) and (C, Section [28.0022](#), [Section 43.22](#), Penal Code, and any other law or regulation that protects students from obscene or harmful content.

QUESTION 34.0: Does your district or charter school protect against access to obscene or harmful content in compliance with the requirements for certification under the Children's Internet Protection Act, 47 USC §254(h)(5)(B) and (C), Section 28.0022, Penal Code, and any other law or regulation that protects students from obscene or harmful content?

Yes

No

Additional Informational Questions (Optional)*

QUESTION 35.0:

Has your LEA used, or do you plan to use, the Texas Resource Review (TRR) to inform local decisions related to instructional materials adoption?

- Yes
- No

QUESTION 35.1:

If "Yes" is selected: In which subject area(s) have you used the TRR to obtain information about the quality of products? *

- English Reading Language Arts
- Spanish Reading Language Arts
- Prekindergarten
- English Phonics
- Spanish Phonics
- Science

QUESTION 36.0:

How likely is it you would recommend TRR to other educators? 0 (Not at all likely) to 10 (Extremely Likely)*

- 1.
- 2.
- 3.
- 4.
- 5.
- 6.
- 7.
- 8.
- 9.
- 10.

QUESTION 37.0:

Assessment Platform: Select the assessment platform (if any) your LEA leverages for unit/module, diagnostic, or interim, and for which type of assessments.

| Product | Interim | Diagnostic | Unit/Module Formatives |
|--|-------------------------------------|-------------------------------------|-------------------------------------|
| Eduphoria | <input checked="" type="checkbox"/> | <input checked="" type="checkbox"/> | <input checked="" type="checkbox"/> |
| DMCA | <input type="checkbox"/> | <input type="checkbox"/> | <input type="checkbox"/> |
| Texas Formative Assessment Resource | <input type="checkbox"/> | <input type="checkbox"/> | <input type="checkbox"/> |
| STAAR Interim | <input checked="" type="checkbox"/> | <input type="checkbox"/> | <input type="checkbox"/> |
| Other: | <input checked="" type="checkbox"/> | <input checked="" type="checkbox"/> | <input type="checkbox"/> |
| <input type="text" value="MAP"/> | | | |
| Other: | <input type="checkbox"/> | <input type="checkbox"/> | <input type="checkbox"/> |
| <input type="text" value="Insert here"/> | | | |
| Other: | <input type="checkbox"/> | <input type="checkbox"/> | <input type="checkbox"/> |
| <input type="text" value="Insert here"/> | | | |

QUESTION 38.0:

Is your LEA planning on using the SBOE-Approved Instructional Materials Allotment?

SBOE-Approved Instructional Materials Allotment - An annual entitlement of \$40 per enrolled student credited to a district's Instructional Materials and Technology Account to procure instructional materials placed on the approved list maintained by the SBOE under TEC §31.022. See TEC, §48.307

- Yes, we are.
- No, we do not have a need for it.
- Unsure, we need more information.

QUESTION 39.0:

Is your LEA planning on using the Open Education Resource Funding Allotment?

Open Education Resource Printing Allotment - An annual entitlement of up to \$20 per enrolled student credited to a district's Instructional Materials and Technology Account for expenses incurred in the printing and shipping of SBOE-approved open education resources. See TEC, §48.308

- Yes, we are.
- No, we do not have a need for it.
- Unsure, we need more information.

Certification 2024-25 Survey Ratification [Printed and uploaded PDF]

In accordance with [Texas Education Code §31.1011](#), school districts and open-enrollment charter schools are required to certify annually to the State Board of Education and the commissioner that, for each subject in the required curriculum other than physical education, students have access to instructional materials that cover all the Texas Essential Knowledge and Skills (TEKS) for the coming school year. Additionally, in accordance with Texas Administrative Code [19 TAC §66.105](#), school districts or charter schools are required to certify that they protect against access to obscene or harmful content in compliance with the requirements for certification under the Children's Internet Protection Act, 47 USC §254(h)(5)(B) and (C).

These certifications must be ratified by local school boards of trustees or governing bodies in public, noticed meetings. Districts and open-enrollment charter schools will be unable to order instructional materials through EMAT until the certifications have been received by the Texas Education Agency (TEA).

Other Certified Subject Areas

QUESTION 40.0:

Please select each subject in the required curriculum below for which your district provides each student with instructional materials that cover all elements of the essential knowledge and skills: [multiple select]

- Career & Technical Education
- Fine Arts
- Health
- Technology Applications
- English Language Proficiency Standards
- Languages other than English

District County Number (6-digit ID):

061912

District Name:

Lake Dallas ISD

Date of Ratification by Local School Board of Trustees or Governing Body:

Signature of the Board President and Secretary or Governing Board Officer

Board President

Date

Board Secretary

After ratification, please scan ALL PAGES of this form and submit to TEA through the electronic Certification of Provision of Instructional Materials Survey

LAKE DALLAS ISD
2024-2025 PROFESSIONAL DEVELOPMENT CALENDAR

| DATE | EVENT |
|--|--|
| BACK TO SCHOOL | |
| July 22 | District Leadership Retreat |
| July 23-24 | Principals & APs |
| July 29-31 | New Hire Training |
| August 5-13 | Campus Professional Development Convocation District Professional Development Content Training Special Populations Falcon Fest Teacher Planning Day Teacher Workday |
| DATE | EVENT |
| FALL SEMESTER | |
| October 11th | Campus Professional Learning Community/ Professional Development Day <ul style="list-style-type: none"> • Analyze BOY Student Data - MAP & 2024 STAAR • Create Small Groups |
| October 14th | Teacher Work Day |
| November 11th | Campus Professional Learning Community/ Professional Development Day <ul style="list-style-type: none"> • Adjusting Small Groups • Creating Tier 2 & Tier 3 Interventions • Enrichment • Implementing Action Steps from Coaching Cycles |
| Twice in the Fall Semester: ½ Day Subs Rotating Between Grade Levels | |
| Pre-K/Kinder/1st/2nd Planning | 3rd/4th/5th Planning |
| 6-8 Math & RLA Planning | 8 Science & SS/English 1/English 2 Planning |
| Algebra 1/US History/Biology Planning | |

**LAKE DALLAS ISD
2024-2025 PROFESSIONAL DEVELOPMENT CALENDAR**

| DATE | EVENT |
|---|--|
| SPRING SEMESTER | |
| January 6th | Campus Professional Learning Community/ Professional Development Day <ul style="list-style-type: none"> ● Analyze 1st Semester Data (MAP) ● Adjust Small Group Instruction ● Review Expectations and Instructional Practices |
| January 7th | Teacher Work Day |
| March 14th | Campus Professional Learning Community/ Professional Development Day <ul style="list-style-type: none"> ● Analyze STAAR Interim ● Progress monitoring of Tier 2 & Tier 3 interventions ● Planning reteach and Small Groups |
| April 21st | Campus Professional Learning Community/ Professional Development Day <ul style="list-style-type: none"> ● Team Planning ● Review Campus Goals |
| Once in the Spring Semester: ½ Day Subs Rotating Between Grade Levels | |
| Pre-K/Kinder/1st/2nd Planning | 3rd/4th/5th Planning |
| 6-8 Math & RLA Planning | 8 Science & SS/English 1/English 2 Planning |
| Algebra 1/US History/Biology Planning | |

Lake Dallas ISD Student Health Advisory Council (SHAC)

- SHAC is a District-level advisory council authorized by Board policy EHAA (Legal)
- The SHAC must hold regular meetings and periodically meet with the Board to provide advice and recommendations on school health programs.
- According to EHAA (Legal) the Board of Trustees shall annually appoint a minimum of five members to the SHAC.
- Members may serve three-year terms and multiple terms are permitted.
- Parents serving on SHAC must live within the district and have currently enrolled students.
- The Board may appoint one or more person from the following:
 - teachers, administrators, district students, health care professionals, business community, law enforcement, senior citizens, clergy, and nonprofit organizations

Recommendation for the 2024-2025 the Board appointed SHAC Members

- Andrew Clemens – Parent
- Courtney Martin – Texas Health Resources
- Josh Medlin – Parent and Current SHAC Chair
- Julie Smith - Parent
- Lisa Walraven – District Health Coordinator/HS Nurse

PROPOSED REVISIONS: 4.1.2024

**Consistent
Application for
Graduating Class**

The District shall apply the same class rank calculation method and rules for local graduation honors for all students in a graduating class, regardless of the school year in which a student first earned high school credit.

Calculation

The District shall include in the calculation of class rank semester grades earned in high school credit courses taken at any grade level, unless excluded below.

The class rank calculation shall not include semester grades from a course that is retaken after a passing grade has been earned, and the new grade shall not be recorded on the transcript.

The calculation shall include failing grades.

Exclusions

The calculation of class rank shall exclude grades earned in physical education; athletics; cheerleading; drill team dance; band; a distance learning course, unless the course is either assigned to the student by the District or offered as a course option along with traditional District courses; any local credit course; or through credit by examination, with or without prior instruction.

Beginning the 2024-2025 school year, a career and technology course taken prior to ninth grade shall be excluded from class rank.

**Weighted Grade
System**

The District shall categorize and weight eligible courses as Advanced, Honors, and Regular in accordance with provisions of this policy and as designated in appropriate District publications.

Categories

Advanced

Eligible Advanced Placement (AP) and dual credit courses shall be categorized and weighted as Advanced courses.

Honors

Eligible courses locally designated as honors shall be categorized and weighted as Honors courses.

Regular

All other eligible courses shall be categorized and weighted as Regular courses.

**Weighted Grade
Point Average**

The District shall convert semester grades earned in eligible courses to grade points in accordance with the following chart and shall calculate a weighted grade point average (GPA):

| Grade | Advanced | Honors | Regular |
|--------------|-----------------|---------------|----------------|
| 100 | 5.0 | 4.5 | 4.0 |
| 99 | 4.9 | 4.4 | 3.9 |
| 98 | 4.8 | 4.3 | 3.8 |

ACADEMIC ACHIEVEMENT
CLASS RANKING

EIC
(LOCAL)

| Grade | Advanced | Honors | Regular |
|-----------------|-----------|----------|----------|
| 97 | 4.7 | 4.2 | 3.7 |
| 96 | 4.6 | 4.1 | 3.6 |
| 95 | 4.5 | 4.0 | 3.5 |
| 94 | 4.4 | 3.9 | 3.4 |
| 93 | 4.3 | 3.8 | 3.3 |
| 92 | 4.2 | 3.7 | 3.2 |
| 91 | 4.1 | 3.6 | 3.1 |
| 90 | 4.0 | 3.5 | 3.0 |
| 89 | 3.9 | 3.4 | 2.9 |
| 88 | 3.8 | 3.3 | 2.8 |
| 87 | 3.7 | 3.2 | 2.7 |
| 86 | 3.6 | 3.1 | 2.6 |
| 85 | 3.5 | 3.0 | 2.5 |
| 84 | 3.4 | 2.9 | 2.4 |
| 83 | 3.3 | 2.8 | 2.3 |
| 82 | 3.2 | 2.7 | 2.2 |
| 81 | 3.1 | 2.6 | 2.1 |
| 80 | 3.0 | 2.5 | 2.0 |
| 79 | 2.9 | 2.4 | 1.9 |
| 78 | 2.8 | 2.3 | 1.8 |
| 77 | 2.7 | 2.2 | 1.7 |
| 76 | 2.6 | 2.1 | 1.6 |
| 75 | 2.5 | 2.0 | 1.5 |
| 74 | 2.4 | 1.9 | 1.4 |
| 73 | 2.3 | 1.8 | 1.3 |
| 72 | 2.2 | 1.7 | 1.2 |
| 71 | 2.1 | 1.6 | 1.1 |
| 70 | 2.0 | 1.5 | 1.0 |
| Below 70 | 0* | 0 | 0 |

* A grade of 60-69 or D in a dual credit course shall not receive high school credit, and grade points shall be assigned as noted above.

ACADEMIC ACHIEVEMENT
CLASS RANKING

EIC
(LOCAL)

| | |
|---------------------------------|---|
| Transferred Grades | <p>When a student transfers semester grades for courses that would be eligible under the Regular category and the District has accepted the credit, the District shall include the grades in the calculation of class rank.</p> <p>When a student transfers semester grades for courses that would be eligible to receive additional weight under the District's weighted grade system, the District shall assign additional weight to the grades based on the categories and grade weight system used by the District.</p> |
| Local Graduation Honors | <p>For the purpose of determining honors to be conferred during graduation activities, the District shall calculate class rank in accordance with this policy and administrative regulations by using grades available at the time of calculation at the end of the third nine-week grading period of the senior year.</p> <p>Dual credit courses for the spring semester shall not be included in the calculation.</p> <p>For the purpose of applications to institutions of higher education, the District shall also calculate class rank as required by state law. The District's eligibility criteria for local graduation honors shall apply only for local recognitions and shall not restrict class rank for the purpose of automatic admission under state law. [See EIC(LEGAL)]</p> |
| Valedictorian and Salutatorian | <p>The valedictorian and salutatorian shall be the eligible students with the highest and second-highest rank, respectively. To be eligible for this local graduation honor, a student must:</p> <ol style="list-style-type: none"><li data-bbox="561 1276 1425 1346">1. Have been continuously enrolled in the District high school for the four semesters immediately preceding graduation;<li data-bbox="561 1367 1425 1436">2. Be graduating after exactly eight semesters of enrollment in high school; and<li data-bbox="561 1457 1425 1524">3. Have completed the foundation program with the distinguished level of achievement. |
| <i>No Ties</i> | <p>In order to recognize only one student as valedictorian and one student as salutatorian, the District shall calculate weighted GPAs to a sufficient number of decimal places so that no ties exist among eligible students.</p> |
| Highest-Ranking Graduate | <p>The student meeting the local eligibility criteria for recognition as the valedictorian shall also be considered the highest-ranking graduate for purposes of receiving the honor graduate certificate from the state of Texas.</p> |

Consistent Application for Graduating Class

The District shall apply the same class rank calculation method and rules for local graduation honors for all students in a graduating class, regardless of the school year in which a student first earned high school credit.

Calculation

The District shall include in the calculation of class rank semester grades earned in high school credit courses taken at any grade level, unless excluded below.

The class rank calculation shall not include semester grades from a course that is retaken after a passing grade has been earned, and the new grade shall not be recorded on the transcript.

The calculation shall include failing grades.

Exclusions

The calculation of class rank shall exclude grades earned in physical education; athletics; cheerleading; drill team dance; band; a distance learning course, unless the course is either assigned to the student by the District or offered as a course option along with traditional District courses; any local credit course; or through credit by examination, with or without prior instruction.

Beginning the 2024-2025 school year, a career and technology course taken prior to ninth grade shall be excluded from class rank.

Weighted Grade System

The District shall categorize and weight eligible courses as Advanced, Honors, and Regular in accordance with provisions of this policy and as designated in appropriate District publications.

Categories
Advanced

Eligible Advanced Placement (AP) and dual credit courses shall be categorized and weighted as Advanced courses.

Honors

Eligible courses locally designated as honors shall be categorized and weighted as Honors courses.

Regular

All other eligible courses shall be categorized and weighted as Regular courses.

Weighted Grade Point Average

The District shall convert semester grades earned in eligible courses to grade points in accordance with the following chart and shall calculate a weighted grade point average (GPA):

| Grade | Advanced | Honors | Regular |
|--------------|-----------------|---------------|----------------|
| 100 | 5.0 | 4.5 | 4.0 |
| 99 | 4.9 | 4.4 | 3.9 |
| 98 | 4.8 | 4.3 | 3.8 |

ACADEMIC ACHIEVEMENT
CLASS RANKING

EIC
(LOCAL)

| Grade | Advanced | Honors | Regular |
|--------------|-----------------|---------------|----------------|
| 97 | 4.7 | 4.2 | 3.7 |
| 96 | 4.6 | 4.1 | 3.6 |
| 95 | 4.5 | 4.0 | 3.5 |
| 94 | 4.4 | 3.9 | 3.4 |
| 93 | 4.3 | 3.8 | 3.3 |
| 92 | 4.2 | 3.7 | 3.2 |
| 91 | 4.1 | 3.6 | 3.1 |
| 90 | 4.0 | 3.5 | 3.0 |
| 89 | 3.9 | 3.4 | 2.9 |
| 88 | 3.8 | 3.3 | 2.8 |
| 87 | 3.7 | 3.2 | 2.7 |
| 86 | 3.6 | 3.1 | 2.6 |
| 85 | 3.5 | 3.0 | 2.5 |
| 84 | 3.4 | 2.9 | 2.4 |
| 83 | 3.3 | 2.8 | 2.3 |
| 82 | 3.2 | 2.7 | 2.2 |
| 81 | 3.1 | 2.6 | 2.1 |
| 80 | 3.0 | 2.5 | 2.0 |
| 79 | 2.9 | 2.4 | 1.9 |
| 78 | 2.8 | 2.3 | 1.8 |
| 77 | 2.7 | 2.2 | 1.7 |
| 76 | 2.6 | 2.1 | 1.6 |
| 75 | 2.5 | 2.0 | 1.5 |
| 74 | 2.4 | 1.9 | 1.4 |
| 73 | 2.3 | 1.8 | 1.3 |
| 72 | 2.2 | 1.7 | 1.2 |
| 71 | 2.1 | 1.6 | 1.1 |
| 70 | 2.0 | 1.5 | 1.0 |
| Below 70 | 0* | 0 | 0 |

* A grade of 60-69 or D in a dual credit course shall not receive high school credit, and grade points shall be assigned as noted above.

ACADEMIC ACHIEVEMENT
CLASS RANKING

EIC
(LOCAL)

| | |
|---------------------------------|---|
| Transferred Grades | <p>When a student transfers semester grades for courses that would be eligible under the Regular category and the District has accepted the credit, the District shall include the grades in the calculation of class rank.</p> <p>When a student transfers semester grades for courses that would be eligible to receive additional weight under the District's weighted grade system, the District shall assign additional weight to the grades based on the categories and grade weight system used by the District.</p> |
| Local Graduation Honors | <p>For the purpose of determining honors to be conferred during graduation activities, the District shall calculate class rank in accordance with this policy and administrative regulations by using grades available at the time of calculation at the end of the third nine-week grading period of the senior year.</p> <p>Dual credit courses for the spring semester shall not be included in the calculation.</p> <p>For the purpose of applications to institutions of higher education, the District shall also calculate class rank as required by state law. The District's eligibility criteria for local graduation honors shall apply only for local recognitions and shall not restrict class rank for the purpose of automatic admission under state law. [See EIC(LEGAL)]</p> |
| Valedictorian and Salutatorian | <p>The valedictorian and salutatorian shall be the eligible students with the highest and second-highest rank, respectively. To be eligible for this local graduation honor, a student must:</p> <ol style="list-style-type: none"><li data-bbox="561 1276 1425 1346">1. Have been continuously enrolled in the District high school for the four semesters immediately preceding graduation;<li data-bbox="561 1367 1425 1436">2. Be graduating after exactly eight semesters of enrollment in high school; and<li data-bbox="561 1457 1425 1524">3. Have completed the foundation program with the distinguished level of achievement. |
| <i>No Ties</i> | <p>In order to recognize only one student as valedictorian and one student as salutatorian, the District shall calculate weighted GPAs to a sufficient number of decimal places so that no ties exist among eligible students.</p> |
| Highest-Ranking Graduate | <p>The student meeting the local eligibility criteria for recognition as the valedictorian shall also be considered the highest-ranking graduate for purposes of receiving the honor graduate certificate from the state of Texas.</p> |

XVII. JOINT CONTRACT ACCEPTANCE AND APPROVAL

IN TESTIMONY HEREOF, this agreement has been executed on behalf of the parties hereto as follows, to-wit:

- (1) It has on the 25th day of January, 2024 been executed by the Denton County Elections Administrator pursuant to the Texas Election Code so authorizing;
- (2) It has on the 15th day of April, 2024 been executed on behalf of the LAKE DALLAS ISD pursuant to an action of the LAKE DALLAS ISD BOARD OF TRUSTEES so authorizing;

ACCEPTED AND AGREED TO BY DENTON COUNTY ELECTIONS ADMINISTRATOR:

APPROVED:



Frank Phillips, CERA

ACCEPTED AND AGREED TO BY THE LAKE DALLAS ISD BOARD OF TRUSTEES:

APPROVED:

ATTESTED:

LANCE STACY, PRESIDENT

MARK TUCKER, SECRETARY

THE STATE OF TEXAS COUNTY OF DENTON

JOINT ELECTION AGREEMENT AND CONTRACT FOR ELECTION SERVICES

This CONTRACT for election services is made by and between the Denton County Elections Administrator and the following political subdivisions, herein referred to as “participating authority or participating authorities” located entirely or partially inside the boundaries of Denton County:

Participating Authorities:

[entities]

This contract is made pursuant to Texas Election Code Sections 31.092 and 271.002 and Texas Education Code Section 11.0581 for a joint May 4, 2024 election to be administered by Frank Phillips, Denton County Elections Administrator, hereinafter referred to as “Elections Administrator.”

RECITALS

Each participating authority listed above plans to hold a General or Special Election on May 4, 2024. Denton County plans to hold county-wide voting for this General Election.

The County owns the Hart InterCivic Verity Voting System, which has been duly approved by the Secretary of State pursuant to Texas Election Code Chapter 122 as amended, and is compliant with the accessibility requirements for persons with disabilities set forth by Texas Election Code Section 61.012. The contracting political subdivisions (participating authorities) desire to use the County’s voting system and to compensate the County for such use and to share in certain other expenses connected with joint elections, in accordance with the applicable provisions of Chapters 31 and 271 of the Texas Election Code, as amended.

NOW THEREFORE, in consideration of the mutual covenants, agreements, and benefits to all parties, IT IS AGREED as follows:

I. ADMINISTRATION

The participating authorities agree to hold a “Joint Election” with Denton County and each other in accordance with Chapter 271 of the Texas Election Code and this agreement. The Elections Administrator shall coordinate, supervise, and handle all aspects of administering the Joint Election as provided in this agreement. Each participating authority agrees to pay the Elections Administrator for equipment, supplies, services, and administrative costs as provided in this agreement. The Elections Administrator shall serve as the administrator for the Joint Election; however, each participating authority shall remain responsible for the decisions and actions of its officers necessary for the lawful conduct of its election. The Elections Administrator shall provide advisory services in connection with decisions to be made and actions to be taken by the officers of each participating authority as necessary.

It is understood that other political subdivisions may wish to participate in the use of the County's Verity voting system and polling places, and it is agreed that the Elections Administrator may enter into other contracts for election services for those purposes, on terms and conditions generally similar to those set forth in this contract. In such cases, costs shall be pro-rated among the participants according to Section XI of this contract.

II. LEGAL DOCUMENTS

Each participating authority shall be responsible for the preparation, adoption, and publication of all required election orders, resolutions, notices, and any other pertinent documents required by the Texas Election Code and/or the participating authority's governing body, charter, or ordinances, except that the Elections Administrator shall be responsible for the preparation and publication of all voting equipment testing notices that are required by the Texas Election Code. Election orders should include language that would not necessitate amending the order if any of the Early Voting and/or Election Day polling places change.

Preparation of the necessary materials for notices and the official ballot shall be the responsibility of each participating authority, including translation to languages other than English. Each participating authority shall provide a copy of their respective election orders and notices to the Elections Administrator.

III. VOTING LOCATIONS

The Elections Administrator shall select and arrange for the use of and payment for all Early Voting and Election Day voting locations. Voting locations will be, whenever possible, the usual voting location for each election precinct in elections conducted by each participating authority and shall be compliant with the accessibility requirements established by Election Code Section 43.034 and the Americans with Disabilities Act (ADA). The proposed voting locations are listed in Exhibit A of this agreement. In the event a voting location is not available or appropriate, the Elections Administrator will arrange for use of an alternate location. The Elections Administrator shall notify the participating authorities of any changes from the locations listed in Exhibit A.

IV. ELECTION JUDGES, CLERKS, AND OTHER ELECTION PERSONNEL

Denton County shall be responsible for the appointment of the presiding judge and alternate judge for each polling location. The Elections Administrator shall make emergency appointments of election officials if necessary.

Upon request by the Elections Administrator, each participating authority agrees to assist in recruiting bilingual polling place officials (fluent in both English and Spanish). In compliance with the Federal Voting Rights Act of 1965, as amended, each polling place containing more than 5% Hispanic population as determined by the 2020 Census shall have one or more election officials who are fluent in both the English and Spanish languages. If a presiding judge is not bilingual, and is unable to appoint a bilingual clerk, the Elections Administrator may recommend a bilingual worker for the polling place. If the Elections Administrator is unable to recommend or recruit a bilingual worker, the participating authority or authorities served by that polling

place shall be responsible for recruiting a bilingual worker for translation services at that polling place.

The Elections Administrator shall notify all election judges of the eligibility requirements of Subchapter C of Chapter 32 of the Texas Election Code, and will take the necessary steps to insure that all election judges appointed for the Joint Election are eligible to serve.

The Elections Administrator shall arrange for the training and compensation of all election judges and clerks. The Election judges and clerks who attend in-person voting equipment training and/or procedures training, shall be compensated at a flat rate of \$78. Election judges and clerks that elect to complete online training shall be compensated at a rate of a flat \$50. In the event that an Election judge or clerk completes both in-person and online training, they shall be compensated for the training resulting in the highest pay and will not be compensated for both trainings.

The Elections Administrator shall arrange for the date, time, and place for presiding election judges to pick up their election supplies. Each presiding election judge will be sent a letter from the Elections Administrator notifying them of their appointment, the dates/times and locations of training and distribution of election supplies, and the number of election clerks that the presiding judge may appoint.

Each election judge and clerk will receive compensation at the hourly rate established by Denton County pursuant to Texas Election Code Section 32.091 and overtime after 40 hours worked per week, if applicable. The election judge, or their designee, will receive an additional sum of \$25.00 for picking up the election supplies and equipment prior to Election Day and for returning the supplies and equipment to the central counting station after the polls close. Likewise, the Presiding Judge in Early Voting, or their designee, will receive an additional sum of \$25.00 for picking up the election supplies prior to the first day of Early Voting and for returning the supplies and equipment to the Elections Department after Early Voting has ended.

The compensation rates established by Denton County are:

Early Voting – Presiding Judge (\$15/hour), Alternate Judge (\$14/ hour), Clerk (\$13/ hour)

Election Day – Presiding Judge (\$15/hour), Alternate Judge (\$14/ hour), Clerk (\$13/ hour)

The Elections Administrator may employ other personnel necessary for the proper administration of the election, as well as, pre and post-election administration. In such cases, costs shall be pro-rated among participants of this contract. Personnel working in support of full-time staff will be expensed on a pro-rated basis and include a time period of one week prior to the election, during the election, and one week post-election. Personnel working in support of the Early Voting Ballot Board and/or central counting station on election night will be compensated at the hourly rate set by Denton County in accordance with Election Code Sections 87.005, 127.004, and 127.006.

If elections staff is required outside of the hours of the office's normal scope of business, the entity(ies) responsible for the hours will be billed for those hours. The Elections Administrator will determine when those hours are necessary, the number of staff and whom are necessary, along with to whom the hours are to be billed. Cost for these hours will be billed at a rate of 1.5 times the staff's hourly rate (See Sections XV #9). The Election Administrator has the right to waive these costs as they see fit.

V. PREPARATION OF SUPPLIES AND VOTING EQUIPMENT

The Elections Administrator shall arrange for delivery of all election supplies and voting equipment including, but not limited to, the County's Verity voting system and equipment, official ballot paper, sample ballots, voter registration lists, and all forms, signs, maps and other materials used by the election judges at the voting locations. The Elections Administrator shall ensure availability of tables and chairs at each polling place and shall procure rented tables and chairs for those polling places that do not have tables and/or chairs. Any additional required materials (required by the Texas Election Code) must be provided by the participating authority, and delivered to the Elections Office thirty-three (33) calendar days (April 1, 2024) prior to Election Day. If this deadline is not met, the material must be delivered by the participating authority, to all Early Voting and Election Day locations affected, prior to voting commencing. The Elections Administrator shall be responsible for conducting all required testing of the voting equipment, as required by Chapters 127 and 129 of the Texas Election Code.

At each polling location, joint participants shall share voting equipment and supplies to the extent possible. The participating authorities shall share a mutual ballot in those precincts where jurisdictions overlap. Multiple ballot styles shall be available in those shared polling places where jurisdictions do not overlap. The Elections Administrator shall provide the necessary voter registration information, maps, instructions, and other information needed to enable the election judges in the voting locations that have more than one ballot style to conduct a proper election.

Each participating authority shall furnish the Elections Administrator a list of candidates and/or propositions showing the order and the exact manner in which the candidate names and/or proposition(s) are to appear on the official ballot (including titles and text in each language in which the authority's ballot is to be printed). **Said list must be provided to the Elections Office within three (3) business days following the last day to file for a place on the ballot** or after the election is ordered, whichever is later. The list of candidates and/or propositions must be completed on the ballot language form provided by the Elections Administrator, the information will preferably be in sentence case format, and must contain candidate contact information for the purposes of verifying the pronunciation of each candidate's name. Each participating authority shall be responsible for proofreading and approving the ballot insofar as it pertains to that authority's candidates and/or propositions. Each participating authority shall be responsible for proofing and approving the audio recording of the ballot insofar as it pertains to that authority's candidates and/or propositions. **The approval must be finalized with the Elections Office within five (5) calendar days of the receipt of the proofs, or the provided proofs shall be considered approved.**

The joint election ballots shall list the County's election first. The joint election ballots that contain ballot content for more than one joint participant because of overlapping territory shall be arranged with the Central Appraisal District, then the appropriate school district ballot content appearing on the ballot, followed by the appropriate city ballot content, and followed by the appropriate water district or special district ballot content.

Early Voting by personal appearance and on Election Day shall be conducted exclusively on Denton County's Verity voting system including provisional ballots.

The Elections Administrator shall be responsible for the preparation, testing, and delivery of the voting equipment for the election as required by the Election Code.

The Elections Administrator shall conduct criminal background checks on the relevant employees upon hiring as required by Election Code 129.051(g).

VI. EARLY VOTING

The participating authorities agree to conduct joint early voting and to appoint the Election Administrator as the Early Voting Clerk in accordance with Sections 31.097 and 271.006 of the Texas Election Code. Each participating authority agrees to appoint the Elections Administrator's permanent county employees as deputy early voting clerks. The participating authorities further agree that the Elections Administrator may appoint other deputy early voting clerks to assist in the conduct of early voting as necessary, and that these additional deputy early voting clerks shall be compensated at an hourly rate set by Denton County pursuant to Section 83.052 of the Texas Election Code. Deputy early voting clerks who are permanent employees of the Denton County Elections Administrator or any participating authorities shall serve in that capacity without additional compensation.

Exhibit A of this document includes locations, dates, and times that voting will be held for Early Voting by personal appearance. Any qualified voter of the Joint Election may vote early by personal appearance at any one of the joint early voting locations. All requests for temporary branch polling places will be considered and determined based on the availability of facility and if it is within the Election Code parameters. All costs for temporary locations including coverage by Election Administration staff will be borne by the requesting authority. The Elections Administrator will determine when those hours are necessary, the number of staff and who are necessary, along with to whom the hours are to be billed. Cost for these hours will be billed at a rate of 1.5 times the staff's hourly rate (See Sections XV #10). The Election Administrator has the right to waive these costs as they see fit.

The standard dates and hours for the May 4, 2024 election will be as follows:

Monday, April 22, 2024 through Saturday, April 27, 2024; 8am – 5pm

Sunday, April 28, 2024; 11am-5pm

Monday, April 29, 2024 through Tuesday, April 30, 2024; 7am-7pm

As Early Voting Clerk, the Elections Administrator shall receive applications for early voting ballots to be voted by mail in accordance with Chapters 31 and 86 of the Texas Election Code. Any requests for early voting ballots to be voted by mail received by the participating authorities shall be forwarded immediately by fax or courier to the Elections Administrator for processing. The address of the Early Voting Clerk is as follows:

Frank Phillips, Early Voting Clerk
Denton County Elections
PO Box 1720
Denton, TX 76202
Email: elections@dentoncounty.gov

Any requests for early voting ballots to be voted by mail, and the subsequent actual voted ballots that are sent by a contract carrier (ie. UPS, FedEx, etc.) shall be delivered to the Early Voting Clerk at the Denton County Elections Department physical address as follows:

Frank Phillips, Early Voting Clerk
Denton County Elections
701 Kimberly Drive, Suite A100
Denton, TX 76208
Email: elections@dentoncounty.gov

The Elections Administrator shall post on the county website, the participating authority's Early Voting Roster on a daily basis. In accordance with Section 87.121 of the Election Code, the daily roster showing the previous day's early voting activity will be posted no later than 11:00 am each business day.

VII. EARLY VOTING BALLOT BOARD

Denton County shall appoint the Presiding Judge of an Early Voting Ballot Board (EVBB) to process early voting results from the Joint Election. The Presiding Judge, with the assistance of the Elections Administrator, shall appoint an Alternate Judge and one or more additional members to constitute the EVBB. The Elections Administrator shall determine the number of EVBB members required to efficiently process the early voting ballots.

VIII. CENTRAL COUNTING STATION AND ELECTION RETURNS

The Elections Administrator shall be responsible for establishing and operating the central counting station to receive and tabulate the voted ballots in accordance with the provisions of the Texas Election Code and of this agreement.

The participating authorities hereby, in accordance with Section 127.002, 127.003, and 127.005 of the Texas Election Code, appoint the following central counting station officials:

Counting Station Manager: Brandy Grimes, Deputy Elections Administrator
Tabulation Supervisor: Jason Slonaker, Technology Resources Coordinator

Presiding Judge: Early Voting Ballot Board Judge
Alternate Judge: Early Voting Ballot Board Alternate Judge

The counting station manager or their representative shall deliver timely cumulative reports of the election results as precincts report to the central counting station and are tabulated by posting on the Election Administrator's Election Night Results website. The manager shall be responsible for releasing unofficial cumulative totals and precinct returns from the election to the joint participants, candidates, press, and general public by distribution of hard copies at the central counting station (if requested) and by posting to the Election Administrator's Election Night Results website. To ensure the accuracy of reported election returns, results printed on the reports produced by Denton County's voting equipment will not be released to the participating authorities at the remote collection locations or from individual polling locations.

The Elections Administrator will prepare the unofficial canvass reports after all precincts have been counted and will deliver a copy of the unofficial canvass to each participating authority as soon as possible after all returns have been tabulated. The Elections Administrator will include the tabulation and precinct-by-precinct results that are required by Texas Election Code Section 67.004 for the participating authorities to conduct their respective canvasses. Each participating authority shall be responsible for the official canvass of its respective election(s), and shall notify the Elections Administrator, or their designee, of the date of the canvass, no later than three days after Election Day.

The Elections Administrator shall be responsible for conducting the post-election manual recount required by Section 127.201 of the Texas Election Code unless a waiver is granted by the Secretary of State. Notification and copies of the recount, if waiver is denied, will be provided to each participating authority and the Secretary of State's Office.

IX. PARTICIPATING AUTHORITIES WITH TERRITORY OUTSIDE DENTON COUNTY

Each participating authority with territory containing population outside of Denton County agrees that they Elections Administrator shall administer only the Denton County portion of those elections. On a case-by-case basis, the Elections Administrator may consider administering an entities election for portions outside of Denton County.

X. RUNOFF ELECTIONS

Each participating authority shall have the option of extending the terms of this agreement through its runoff election, if applicable. In the event of such runoff election, the terms of this agreement shall automatically extend unless the participating authority notifies the Elections Administrator in writing within three (3) business days of the original election.

Each participating authority shall reserve the right to reduce the number of early voting locations and/or Election Day voting locations in a runoff election.

Each participating authority eligible to hold runoff elections agrees that the date of the runoff election, if necessary, shall be determined by the Secretary of State, with early voting being held in accordance with the Election Code.

XI. ELECTION EXPENSES AND ALLOCATION OF COSTS

The participating authorities agree to share the costs of administering the Joint Election.

Allocation of general expenses, which are not directly attributable to an individual polling location, will be expensed by each participating authority's percentage of registered voters of the total registered voters of all participating authorities.

Expenses for Early Voting by personal appearance shall be allocated based upon the actual costs associated with each early voting location. Each participating authority shall be responsible for an equal portion of the actual costs associated with the early voting locations within their jurisdiction. Participating authorities that do not have a polling location within their jurisdiction shall pay an equal portion of the nearest polling location. If an entity requests an Early Voting location outside of their jurisdiction and the request is granted, the participating authority shall be responsible for an equal portion of the actual cost associated with the early voting location requested.

Election Day location expenses will be allocated based on each participating authority's percentage of registered voters assigned to each polling place.

In the event that participating authorities with overlapping boundaries cannot make an agreement on Early Voting and/or Election Day locations, the requesting participating authority agrees to bear the entire expense of the location.

Each participating authority requesting additional hours, outside of the standard hours, for a location or locations, agree to split the cost of the additional open hours equally amongst the requesting participating authorities.

Costs for Early Voting by mail, in-person ballots, provisional ballots, and Poll Pad paper shall be allocated according to the actual number of ballots issued to each participating authority's voters and the cost shared equally amongst participating authorities of each ballot style.

Each participating authority agrees to pay the Elections Administrator an administrative fee equal to ten percent (10%) of its total billable costs in accordance with Section 31.100(d) of the Texas Election Code.

The Denton County Elections Administrator shall deposit all funds payable under this contract into the appropriate fund(s) within the county treasury in accordance with Election Code Section 31.100.

The Denton County Elections Administrator reserves the right to adjust the above formulas in agreement with an individual jurisdiction if the above formula results in a cost allocation that is inequitable.

If any participating authority makes a special request for extra Temporary Branch Early Voting by Personal Appearance locations as provided by the Texas Election Code, that entity agrees to pay the entire cost for that request.

Participating authorities having the majority of their voters in another county, and fewer than 500 registered voters in Denton County, and that do not have an Election Day polling place or early voting location within their Denton County territory shall pay a flat fee of \$750 for election expenses.

Election expenses, including but not limited to, overtime charges for Election Office staff, and any unforeseen expenses needed to conduct the election, will be borne by the participating authority or authorities, affected.

The fee for programming each participating authority's election will be based on the number of races within their election. The fee schedule is as follows:

| Programming Fees | |
|-------------------------|-----------------|
| # of Races | DCEA fee |
| 1-5 | \$750.00 |
| 6-10 | \$1,265.00 |
| 11-20 | \$1,650.00 |
| 21-40 | \$2,090.00 |
| 41-75 | \$2,640.00 |
| 76-100 | \$3,135.00 |

XII. WITHDRAWAL FROM CONTRACT DUE TO CANCELLATION OF ELECTION

Any participating authority may withdraw from this agreement and the Joint Election should it cancel its election in accordance with Sections 2.051 - 2.053 of the Texas Election Code. The withdrawing authority is fully liable for any expenses incurred by the Denton County Elections Administrator on behalf of the authority plus an administrative fee of ten percent (10%) of such expenses. Any monies deposited with the Elections Administrator by the withdrawing authority shall be refunded, minus the aforementioned expenses and administrative fees, if applicable.

It is agreed that any of the joint election early voting locations that are not within the boundaries of one or more of the remaining participating authorities, with the exception of the early voting location at the Denton County Elections Building, may be dropped from the joint election unless one or more of the remaining participating authorities agreed to fully fund such location(s). In the event that any early voting location is eliminated under this section, as addendum to the contract shall be provided to the remaining participants within five days after notification of all intents to withdraw have been received by the Elections Administrator.

XIII. RECORDS OF THE ELECTION

The Elections Administrator is hereby appointed general custodian of the voted ballots and all records of the Joint Election as authorized by Section 271.010 of the Texas Election Code.

Access to the election records shall be available to each participating authority as well as to the public in accordance with applicable provisions of the Texas Election Code and the Texas Public Information Act. The election records shall be stored at the offices of the Elections Administrator or at an alternate facility used for storage of county records. The Elections Administrator shall ensure that the records are maintained in an orderly manner so that the records are clearly identifiable and retrievable.

Records of the election shall be retained and disposed of in accordance with the provisions of Section 66.058 of the Texas Election Code. If records of the election are involved in any pending election contest, investigation, litigation, or open records request, the Elections Administrator shall maintain the records until final resolution or until final judgment, whichever is applicable. It is the responsibility of each participating authority to bring to the attention of the Elections Administrator any notice of pending election contest, investigation, litigation or open records request which may be filed with the appropriate participating authority.

XIV. RECOUNTS

A recount may be obtained as provided by Title 13 of the Texas Election Code. By signing this document, the presiding officer of the contracting participating authorities agree that any recount shall take place at the office of the Elections Administrator, and that the Elections Administrator shall serve as Recount Supervisor, and the participating authority's official or employee who performs the duties of a secretary under the Texas Election Code shall serve as Recount Coordinator.

The Elections Administrator agrees to provide advisory services to each participating authority as necessary to conduct a proper recount.

XV. MISCELLANEOUS PROVISIONS

1. It is understood that to the extent space is available, other districts and political subdivisions may wish to participate in the use of the County's election equipment and voting places, and it is agreed that the Elections Administrator may contract with such other districts or political subdivisions for such purposes and that in such event there may be an adjustment of the pro-rata share to be paid to the County by the participating authorities.
2. The Elections Administrator shall file copies of this document with the Denton County Treasurer and the Denton County Auditor in accordance with Section 31.099 of the Texas Election Code.

3. Nothing in this contract prevents any party from taking appropriate legal action against any other party and/or other election personnel for a breach of this contract or a violation of the Texas Election Code.
4. This agreement shall be construed under and in accord with the laws of the State of Texas, and all obligations of the parties created hereunder are performable in Denton County, Texas.
5. In the event that one of more of the provisions contained in this Agreement shall for any reason be held to be invalid, illegal, or unenforceable in any respect, such invalidity, illegality, or unenforceability shall not affect any other provision hereof and this agreement shall be construed as if such invalid, illegal, or unenforceable provision had never been contained herein.
6. All parties shall comply with all applicable laws, ordinances, and codes of the State of Texas, all local governments, and any other entities with local jurisdiction.
7. The waiver by any party of a breach of any provision of this agreement shall not operate as or be construed as a waiver of any subsequent breach.
8. Any amendments of this agreement shall be of no effect unless in writing and signed by all parties hereto.
9. Failure for a participating authority to meet the deadlines as outline in this contract may result in additional charges, including but not limited to, overtime charges, etc.

Elections Staffing Hourly Rate (includes all benefit pay):

| | |
|----------------------------------|---------------------|
| Absentee Voting Coordinator | \$46.798 |
| Voter Registration Clerk | \$34.157 - \$37.309 |
| Technology Resources Coordinator | \$48.225 |
| Elections Technician | \$31.655 - \$38.186 |
| Voter Registration Coordinator | \$41.415 |
| Training Coordinator | \$47.168 |
| Election Coordinator | \$38.718 |

XVI. COST ESTIMATES AND DEPOSIT OF FUNDS

The total estimated obligation for each participating authority under the terms of this agreement is listed below. The exact amount of each participating authority's obligation under the terms of this agreement shall be calculated after the May 4, 2024 election (or runoff election, if applicable). The participating authority's obligation shall be paid to Denton County within 30 days after the receipt of the final invoice from the Denton County Elections Administrator.

The total estimated obligation for each participating authority under the terms of this agreement shall be provided within 45 days after the last deadline for ordering an election:

[costs]

v.0524

[pagebreak]

THIS PAGE INTENTIONALLY BLANK.

Lake Dallas ISD Local Policy Updates

The following Legal and Local policy updates are in reference to the revised District of Innovation Plan approved by the District Education Improvement Committee on February 22nd, 2024 and then approved by the Board of Trustees on February 26th, 2024.

| Code | Update |
|-------------|--|
| DBA | DOI link will only be in LEGAL |
| DCA | DOI link will only be in LEGAL; Local policy deleted |
| DK | DOI link will only be in LEGAL |
| DNA | DOI link will only be in LEGAL |
| EB | DOI link will only be in LEGAL |
| EEB | DOI link will only be in LEGAL |
| FDA | DOI link will be in both the LOCAL and LEGAL policies since this exemption is not a law but a commissioner decision |
| FEC | DOI link will only be in LEGAL |
| FO | DOI link will only be in LEGAL |

The following Legal policies will have the DOI link:

- EB
- EEB
- FEC
- DCA
- FO
- DBA
- DK
- FDA
- DNA
- DNB
- EIE

PROPOSED REVISIONS: 3.6.2024

~~**Note:** This local policy has been revised in accordance with the District's innovation plan.⁴~~

Student Code of Conduct

The District's rules of discipline are maintained in the Board-adopted Student Code of Conduct and are established to support an environment conducive to teaching and learning.

Rules of conduct and discipline shall not have the effect of discriminating on the basis of gender, race, color, disability, religion, ethnicity, or national origin.

At the beginning of the school year and throughout the school year as necessary, the Student Code of Conduct shall be:

1. Posted and prominently displayed at each campus or made available for review in the principal's office, as required by law; and
2. Made available on the District's website and/or as a hard copy to students, parents, teachers, administrators, and others on request.

Revisions

Revisions to the Student Code of Conduct approved by the Board during the year shall be made available promptly to students and parents, teachers, administrators, and others.

~~**Campus Behavior Coordinator**~~

~~In accordance with the District's innovation plan, the District shall be exempt from the state law requiring that a single person at each campus be designated to serve as the campus behavior coordinator (CBC). Each CBC shall comply with the duties and responsibilities of a CBC defined in state law and District policy.~~

Extracurricular Standards of Behavior

With the approval of the principal and Superintendent, sponsors and coaches of extracurricular activities may develop and enforce standards of behavior that are higher than the District-developed Student Code of Conduct and may condition membership or participation in the activity on adherence to those standards. Extracurricular standards of behavior may take into consideration conduct that occurs at any time, on or off school property.

A student shall be informed of any extracurricular behavior standards at the beginning of each school year or when the student first begins participation in the activity. A student and his or her parent shall sign and return to the sponsor or coach a statement that they have read the extracurricular behavior standards and consent to them as a condition of participation in the activity.

Standards of behavior for an extracurricular activity are independent of the Student Code of Conduct. Violations of these standards of behavior that are also violations of the Student Code of Conduct may result in independent disciplinary actions.

A student may be removed from participation in extracurricular activities or may be excluded from school honors for violation of extracurricular standards of behavior for an activity or for violation of the Student Code of Conduct.

“Parent” Defined

Throughout the Student Code of Conduct and discipline policies, the term “parent” includes a parent, legal guardian, or other person having lawful control of the child.

General Discipline Guidelines

A District employee shall adhere to the following general guidelines when imposing discipline:

1. A student shall be disciplined when necessary to improve the student’s behavior, to maintain order, or to protect other students, school employees, or property.
2. A student shall be treated fairly and equitably. Discipline shall be based on an assessment of the circumstances of each case. Factors to consider shall include:
 - a. The seriousness of the offense;
 - b. The student’s age;
 - c. The frequency of misconduct;
 - d. The student’s attitude;
 - e. The potential effect of the misconduct on the school environment;
 - f. Requirements of Chapter 37 of the Education Code; and
 - g. The Student Code of Conduct adopted by the Board.
3. Before a student under 18 is assigned to detention outside regular school hours, notice shall be given to the student’s parent to inform him or her of the reason for the detention and permit arrangements for necessary transportation.

Corporal Punishment

The Board prohibits the use of corporal punishment in the District. Students shall not be spanked, paddled, or subjected to other physical force as a means of discipline for violations of the Student Code of Conduct.

Physical Restraint

Note: A District employee may restrain a student with a disability who receives special education services only in accordance with law. [See FOF(LEGAL)]

Within the scope of an employee's duties, a District employee may physically restrain a student if the employee reasonably believes restraint is necessary in order to:

1. Protect a person, including the person using physical restraint, from physical injury.
2. Obtain possession of a weapon or other dangerous object.
3. Protect property from serious damage.
4. Remove a student refusing a lawful command of a school employee from a specific location, including a classroom or other school property, in order to restore order or to impose disciplinary measures.

⁴ ~~Innovation Plan: <https://www.ldisd.net/>~~

PROPOSED REVISIONS: 3.6.2024

~~**Note:** This local policy has been revised in accordance with the District's innovation plan.⁴~~

**Absences
Considered**

This policy shall apply to a student who has not been in attendance for 90 percent of the days the class is offered.

Except as otherwise provided by law, all absences incurred while enrolled in the District shall be considered in determining whether a student has attended the required percentage of days under this policy.

~~Exception~~

~~In accordance with the District's innovation plan, the District shall be exempt from portions of the state law regarding student minimum attendance to earn credit or a final grade. Absences related to participation in extracurricular activities, cocurricular activities, academic activities, and other local level extenuating circumstances shall not be considered in determining whether a student has attended the required percentage of days under this policy.~~

**Attendance
Committees**

The Board shall establish an attendance committee or as many committees as necessary for efficient implementation of Education Code 25.092.

The Superintendent shall make the specific appointments in accordance with legal requirements.

**Parental Notice of
Excessive Absences**

A student and the student's parent or guardian shall be given written notice prior to and at such time when a student's attendance in any class drops below 90 percent of the days the class is offered.

**Methods for
Regaining Credit or
Awarding a Final
Grade**

When a student's attendance drops below 90 percent but remains at least at 75 percent of the days the class is offered, the student may earn credit for the class or a final grade by completing a plan approved by the principal. This plan must provide for the student to meet the instructional requirements of the class as determined by the principal.

If the student fails to successfully complete the plan, or when a student's attendance drops below 75 percent of the days the class is offered, the student, parent, or representative may request award of credit or a final grade by submitting a written petition to the appropriate attendance committee.

Petitions for credit or a final grade may be filed at any time the student receives notice but, in any event, no later than the last day of classes.

The attendance committee shall review the student's entire attendance record and the reasons for absences and shall determine whether to award credit or a final grade. The attendance committee may also, whether a petition is filed or not, review the records of all students whose attendance drops below 90 percent of the days the class is offered.

A student who has lost credit or has not received a final grade because of excessive absences may regain credit or be awarded a final grade by fulfilling the requirements established by the attendance committee.

Personal Illness

The principal or attendance committee may require verification from a health-care provider in accordance with administrative regulations as a condition of classifying an absence for personal illness as one for which there are extenuating circumstances.

Best Interest Standard

In reaching consensus regarding a student's absences and how the student can be awarded credit or a final grade, the attendance committee shall attempt to ensure that its decision is in the best interest of the student. The Superintendent shall develop administrative regulations to document the attendance committee's decision.

Guidelines on Extenuating Circumstances

The attendance committee shall consider whether a student has mastered the essential knowledge and skills and maintained passing grades in the course or subject.

When makeup work is completed satisfactorily, the attendance committee shall consider extracurricular absences and other excused absences as days of attendance for award of credit or a final grade. [See FEA]

The attendance committee shall consider whether the reasons for the absences were out of the parent's or student's control and whether documentation for the absence is acceptable.

The student or parent shall be given an opportunity to present any information to the committee about the absences and to discuss ways to earn or regain credit or be awarded a final grade.

Imposing Conditions for Awarding Credit or a Final Grade

The attendance committee shall consider the student's unique circumstances and, if necessary, shall impose conditions for awarding credit or a final grade that permit the student to meet the instructional requirements of the class rather than assigning a student to attend a specified program for an amount of time equivalent to the student's absences. Conditions may include:

1. Maintaining attendance standards for the rest of the semester.

2. Completing additional assignments, as specified by the committee or teacher.
3. Attending tutorial sessions as scheduled.
4. Completing other instructional programs, as specified by the committee.
5. Taking an examination to earn credit. [See EHDB]

In all cases, the student must earn a passing grade in order to receive credit.

Appeal Process

A parent or student may appeal the decision of the attendance committee in accordance with FNG(LOCAL).

⁴~~Innovation Plan: <https://www.ldisd.net/>~~

PROPOSED REVISIONS: 3.6.2024

Note: This local policy has been revised in accordance with the District's [innovation plan](#).¹

Authority

The Superintendent is authorized to accept or reject any transfer requests, provided that such action is without regard to race, religion, color, sex, disability, national origin, or ancestral language.

Resident Who Becomes a Nonresident

A resident student who becomes a nonresident during the course of a grading period shall be permitted to continue for the remainder of the grading period, provided there are no discipline, attendance, or transportation problems.

When the student becomes a nonresident, the parent may submit an open-enrollment transfer form. If the student meets the criteria established in administrative guidelines, the student may remain at the current campus until the end of the school year.

Open Enrollment

Annually, the Superintendent may designate an open-enrollment period that may be extended or reopened.

Transfer Request

During this period each school year, a nonresident student, including the child of a nonresident District employee, may file an application for transfer with the Superintendent ~~or designee~~. **Transfers shall be granted for one regular school year at a time.**

An open-enrollment transfer shall be approved by the campus principal and the Superintendent ~~or designee~~. A transfer shall not be approved that would limit the educational opportunities of resident students.

Factors

In approving transfers, the Superintendent ~~or designee~~ shall consider availability of space and instructional staff and the student's disciplinary history, attendance records, and academic records.

Transfer Conference

The accepting campus may require a conference with the parents and may request written acknowledgment of the criteria for admission as a transfer.

Children of District Employees

Children of nonresident District employees who are otherwise eligible for transfer under this policy shall have their applications considered first.

Transfer Agreements

A transfer student shall be notified in the written transfer agreement that he or she must follow all rules and regulations of the District.

~~In accordance with the District's innovation plan, the District shall be exempt from state law requiring transfers to be for a one year~~

~~period. Therefore, violation of the terms of the agreement may result in revocation of the agreement during the school year or may result in a transfer request not being approved the following year.~~

In accordance with the District's innovation plan, the District is exempt from the requirement for transfers to be for a one-year period. Therefore, violation of the terms of the agreement may result in revocation of the agreement during the school year or a transfer request not being approved the following year.

Tuition

If the District charges tuition, the amount shall be set by the Board, within statutory limits.

Waivers

The Board may waive tuition for a student based on financial hardship upon written application by the student, parent, or guardian. [See FP]

Nonpayment

The District may initiate withdrawal of students whose tuition payments are delinquent.

Appeals

Any appeals shall be made in accordance with FNG(LOCAL) and GF(LOCAL), as appropriate.

¹ Innovation Plan: <https://www.ldisd.net/>

DELETE POLICY: 3.6.2024

Note: This local policy has been revised in accordance with the District's [innovation plan](#).¹

Class Size Ratio

In accordance with the District's innovation plan, the District shall be exempt from the state law that requires a district not to enroll more than 22 students in a prekindergarten–grade 4 class.

When enrollment reaches 24 students in a prekindergarten–grade 4 class, the Board shall be notified.

¹ Innovation Plan: <https://www.ldisd.net/>

PROPOSED REVISIONS: 3.6.2024

Note: ~~This local policy has been revised in accordance with the District's innovation plan.~~⁴

School Start Date

~~In accordance with the District's innovation plan, the District shall be exempt from the state law that generally prohibits instruction for students from beginning before the fourth Monday in August.~~

School Calendar

The Superintendent shall be authorized to approve variations from the Board-adopted school calendar, as necessary.

School Closure

The Board delegates to the Superintendent the authority to close schools for reasons of public health and safety.

⁴Innovation Plan: <https://www.ldisd.net/>

PROPOSED REVISIONS: 3.6.2024

~~**Note:** — This local policy has been revised in accordance with the District's innovation plan.⁴~~

T-TESS

The District shall appraise teachers using the Texas Teacher Evaluation and Support System (T-TESS) in accordance with law and administrative regulations.

The Board shall approve a list of certified appraisers who can appraise a teacher in place of the teacher's supervisor.

~~In accordance with the District's innovation plan, the District shall be exempt from the provisions in state law requiring the use of state-mandated assessment scores as one of the evaluation measures for teachers.~~

Annual Appraisal

District teachers shall be appraised annually.

Exception

Teachers who are eligible for less frequent evaluations in accordance with law [see DNA(LEGAL)] and the local criteria established in this policy shall be appraised in accordance with the provisions below.

Less-Than-Annual

Eligibility

In addition to meeting the eligibility requirements in state rules, to be eligible for less-than-annual evaluations under the T-TESS, a teacher shall:

1. Be employed on an educator term contract;
2. Hold SBEC certification;
3. Be assigned in his or her certification area;
4. Have been employed by the District for at least three years;
5. Have served in the current teaching assignment for at least two years;
6. Have served at the current campus for at least two years; and
7. Have been supervised by the current principal for at least two years.

Frequency

Eligible teachers shall be appraised every two years.

During any school year when a complete appraisal is not scheduled for an eligible teacher, either the teacher or the principal may require that an appraisal be conducted by providing written notice to the other party.

PERFORMANCE APPRAISAL
EVALUATION OF TEACHERS

DNA
(LOCAL)

A teacher's supervisor shall have the authority to return a teacher to the traditional appraisal cycle as a result of performance deficiencies documented in accordance with state rule.

*Annual Review
Process*

In the years in which a T-TESS appraisal is not scheduled for an eligible teacher, the teacher shall participate in an annual review process that includes the elements listed in state rule.

The annual review process shall produce a written document to be presented to the teacher, signed by the teacher and supervisor, and maintained in the personnel file.

⁴ ~~Innovation Plan: <https://www.ldisd.net/>~~

PROPOSED REVISIONS: 3.6.2024

~~**Note:** — This local policy has been revised in accordance with the District's innovation plan.⁴~~

Superintendent's Authority

All personnel are employed subject to assignment and reassignment by the Superintendent or designee when the Superintendent determines that the assignment or reassignment is in the best interest of the District. Reassignment shall be defined as a transfer to another position, department, or facility that does not necessitate a change in the employment contract of a contract employee. Any change in an employee's contract shall be in accordance with policy DC.

Any employee may request reassignment within the District to another position for which he or she is qualified.

Campus Assignments

The principal's criteria for approval of campus assignments and reassignments shall be consistent with District policy regarding equal opportunity employment, and with staffing patterns approved in the District and campus plans. [See BQ series] In exercising their authority to approve assignments and reassignments, principals shall work cooperatively with the central office staff to ensure the efficient operation of the District as a whole.

~~In accordance with the District's local innovation plan exemption regarding SBEC certification, the Superintendent shall have the authority to approve a request by the principal for a qualified individual with experience in a career and technical education (CTE) field to teach a CTE course. A qualified individual may also teach languages other than English (LOTE); dual credit; science, technology, engineering, arts, and mathematics (STEAM); and hard-to-fill courses. All other teaching assignments shall require certification in accordance with state law. [See DBA]~~

Supplemental Duties

Noncontractual supplemental duties for which supplemental pay is received may be discontinued by either party at any time. An employee who wishes to relinquish a paid supplemental duty may do so by notifying the Superintendent or designee in writing. Paid supplemental duties are not part of the District's contractual obligation to the employee, and an employee shall hold no expectation of continuing assignment to any paid supplemental duty.

Work Calendars and Schedules

Subject to the Board-adopted budget and compensation plan and in harmony with employment contracts, the Superintendent shall determine required work calendars for all employees. [See DC, EB]

ASSIGNMENT AND SCHEDULES

DK
(LOCAL)

Daily time schedules for all employees shall be determined by the Superintendent or designee and principals.

~~⁴Innovation Plan: <https://www.ldisd.net/>~~

DELETE POLICY: 3.6.2024

Note: This local policy has been revised in accordance with the District's [innovation plan](#).¹

**Maximum
Probationary
Contract Period**

In accordance with the District's innovation plan, the District shall be exempt from the state law regarding the maximum length of time an experienced teacher may be employed on a probationary contract. At the recommendation of the Superintendent, a probationary contract may be renewed for an additional one-year period for a person who has been employed as a teacher in public education for at least five of the eight years preceding employment by the District.

¹ Innovation Plan: <https://www.ldisd.net/>

PROPOSED REVISIONS: 3.6.2024

~~**Note:** — This local policy has been revised in accordance with the District's innovation plan.⁴~~

Updating Credentials

All employees who have earned certificates, endorsements, or degrees of higher rank since the previous school year shall file with the District:

1. An official college transcript showing the highest degree earned and date conferred.
2. Proof of the certificate or endorsement.

Contract Personnel

The Superintendent or designee shall ensure that contract personnel possess valid credentials before issuing contracts.

~~**State Teacher Certification**~~

~~In accordance with the District's innovation plan, the District shall be exempt from the state law that generally requires school districts to hire teachers who are certified by the State Board for Educator Certification. State certification shall not be required for teachers of career and technical education (CTE) courses; courses in languages other than English (LOTE); dual credit courses; science, technology, engineering, arts, and mathematics (STEAM) courses; and hard-to-fill courses. All other teaching assignments shall require certification in accordance with state law. [See DK]~~

Social Security Number

The District shall not use an employee's social security number as an employee identifier, except for tax purposes [see DC]. In accordance with law, the District shall keep an employee's social security number confidential.

⁴ Innovation Plan: <https://www.ldisd.net/>

FINALSITE ORDER

This Finalsite Order (the “**Order**”) is entered into by and between Active Internet Technologies, dba Finalsite (“**Finalsite**”) and Lake Dallas Independent School District (“**Customer**”) and sets forth the terms of Customer’s use of the products and services set forth below (“**Pricing Summary**”). This Order, together with the Master Terms and Conditions for Services (the “**Master Terms**”) located at <http://www.finalsite.com/masterterms/useducationagencies> and incorporated herein by this reference, form the entire agreement between the parties in respect of the products and services set forth below. Each of the individuals executing this Order represent and warrant that he or she is authorized to execute this Order on behalf of Customer or Finalsite, as applicable. Unless otherwise specified herein, any capitalized terms used in this Order shall have the meaning defined in the Master Terms. The “**Effective Date**” of this Order is the date on which both parties have signed this Order as reflected in the signature lines below.

In consideration of the promises set forth herein, and other good and valuable consideration, the receipt of which are hereby acknowledged, the parties hereby agree as follows:

A. Pricing Summary

Creative and Deployment Services Package

Blackboard WCM Composer Upgrade

The Statement of Work ('SOW') for this Creative Services Package can be reviewed here <https://www.finalsite.com/sow-wcm-conv>

Composer CMS Platform

Core Communications Platform - Blackboard WCM Conversion

View a detailed description of what's included in your software package here <https://www.finalsite.com/wcm-conv-pkg>

Products Included in Communications Core Platform - Blackboard WCM Conversion

| | |
|--|---|
| Finalsite Composer Content Management System | Granular Permissions |
| Admin Users, Editors (18) | HTTPS Implementation |
| Admins with ticketing rights (6) | Knowledge Base and Product Training Resources |
| Basic Integrated Site Search | Mobile Friendly, Responsive Designs |
| Calendar Manager | News / Blogs via Posts (24 boards pooled) |
| Website cloud storage / 120 GB | Page Based Notifications (Unlimited) |
| Comprehensive Training Program | Published Pages (Unlimited) |
| Content Migration for Tiers 1, 2, 3 | Resources (Media, Galleries, Document Library) |
| District Site and 5 Additional Sites | Secure Hosting & CDN |
| Drag - and - Drop Page Elements | Single Sign-On |
| Faculty / Staff Directory (public facing) | Social Media Feeds for Districts - Standard (6) |
| Faculty / Staff Portal | Standard Support Plan |
| Forms Manager (24 forms pooled) | |

Additional Products or Services:

Modules

| | |
|--------------------------------------|--|
| Weglot Pro (5 languages, 200K words) | |
|--------------------------------------|--|

| | |
|-------------------------------|--|
| Training & Support | |
| Support Plan - Priority | |

Community Engagement Products:
*[x] indicates product removed * Indicates products added*

| | |
|-----------------------------|--|
| Community Engagement | |
| TEACHER COMMUNICATION | |

| | |
|---------------------------|--|
| Mass Notifications | |
| MASS NOTIFICATIONS | |

| | |
|------------------------------|--|
| Web Community Manager | |
| WCM ESSENTIAL | |

Services: Initial Term and Fees:

The initial term of this Order is for the (5) year period beginning from the Effective Date, unless otherwise outlined in the schedule below (the "Initial Term").

Fees for the Initial Term for the Services specified in the table above are set forth below:

| |
|-------------------------------|
| Total Setup Cost (USD) |
| \$ 0 |

| Schedule | Amount |
|------------------------|-----------|
| Period 1 - Sep 01 2023 | \$ 20,580 |
| Period 2 - Sep 01 2024 | \$ 20,580 |
| Period 3 - Sep 01 2025 | \$ 20,580 |
| Period 4 - Sep 01 2026 | \$ 20,580 |
| Period 5 - Sep 01 2027 | \$ 20,580 |

B. Payment Terms

1. All fees for the initial year of this Order shall be due as follows: (i) Set Up fees shall be invoiced on the Effective Date of this Order and shall be due and payable upon receipt of invoice; (ii) fees for Year 1 (described in the fee table above) shall be invoiced on the Effective Date of this Order or the first day of Year 1, whichever is later, and shall be due and payable upon receipt of invoice; (iii) fees for each subsequent Year of the Initial Term, and for each Renewal Term, shall be invoiced on the commencement of such Year or Renewal Term (as applicable) and shall be due and payable upon receipt of invoice. Fees for any other Services, and for reimbursable expenses, shall be invoiced in accordance with the Master Terms or this Order and shall be due and payable upon receipt of invoice.
2. Unless otherwise specified in the Special Provisions above, this Order Form shall be renewed automatically for successive periods of (5) years (each a "Renewal Term") after the expiration of the Initial Term and any subsequent Renewal Term, unless Client provides AIT, or AIT provides Client, with a written notice to the contrary ninety (90) days prior to the end of the Initial Term or Renewal Term, as applicable.
3. Unless otherwise specified, all dollars (\$) are United States currency.
4. Sales/VAT Tax: If applicable, a copy of Customer's Sales/VAT Tax Direct Pay Certificate or its Sales/VAT Tax Exemption Certificate must be returned with this Order Form. Otherwise, Finalsite will invoice Customer for applicable sales, use and other transactional taxes due in connection with the Services or the fees due therefor.
5. Except as otherwise specified in this Order, fees are subject to increase in accordance with the applicable provisions of the Master Terms.

By signing below, Finalsite and Customer each agree to the terms and conditions of this Order and the Master Terms.

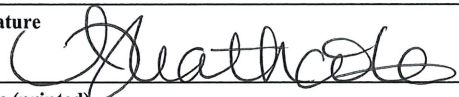
| |
|--|
| Client: Lake Dallas Independent School District |
| Signature  |
| Name (printed) Dr. Shorr Heathcote |
| Title (printed) Chief Administrative Officer |
| Date April 11, 2023 |

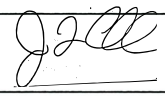
| |
|--|
| Active Internet Technologies ("AIT") |
| Signature  |
| Name (printed) Jim Calabrese |
| Title (printed) CFO |
| Date 4/12/2023 |

As the Customer Contact, by initialing in this box, I agree on behalf of Customer that I have read the Statement of Work ('SOW') and understand the expected deliverables for Finalsite as well as for Customer's project team. I understand that the project timeline is a good faith estimate which is dependent on, among other factors, Customer's ability to meet respective Customer tasks and deadlines.

C. Client Contact Information

Please fill out the following information, which will be used by our deployment & accounting teams.

| | |
|--|------------------------|
| Billing Contact | Anne Haehn |
| Title | Director of Accounting |
| Address Po Box 548 | |
| City, State Zip Lake Dallas, TX 75065-0548 | |
| Phone | 940-497-4039 |
| Email | ahaehn@ldisd.net |

| | |
|------------------------|-----------------------------|
| Project Contact | Melaynee Broadstreet |
| Title | Assistant to Superintendent |
| Phone | 940-497-8401 |
| Email | mbroadstreet@ldisd.net |

| | |
|---|------------------------------|
| *Executive Sponsor (Superintendent, Head of School, CFO, etc.) | |
| | Dr. Shorr Heathcote |
| Title | Chief Administrative Officer |
| Email | sheathcote@ldisd.net |

*The Executive Sponsor should be separate from the Project Contact and is typically the Superintendent, Head of School, Business Manager, CFO, etc.

This **Finalsite Order (the 'Order')** is entered into by and between Active Internet Technologies, dba Finalsite ('Finalsite') and Lake Dallas Independent School District ("Customer") and sets forth the terms of Customer's use of the products and services set forth below ("**Pricing Summary**"). This Order, together with the Master Terms and Conditions for Services (the "**Master Terms**") located at <https://www.finalsite.com/masterterms/useducationagencies> and incorporated herein by this reference, form the entire agreement between the parties in respect of the products and services set forth below. Each of the individuals executing this Order represent and warrant that he or she is authorized to execute this Order on behalf of Customer or Finalsite, as applicable. Unless otherwise specified herein, any capitalized terms used in this Order shall have the meaning defined in the Master Terms.

In consideration of the promises set forth herein, and other good and valuable consideration, the receipt of which are hereby acknowledged, the parties hereby agree as follows:

A. Products and Services Pricing Summary

** Indicates products added*

[X] Indicates products removed

CMS Platform

| Setup and Creative and Professional Services | |
|---|--|
| <p>* Software Setup View a detailed description of what is included in your software package here https://www.finalsite.com/ssu</p> | |
| Add-Ons | |
| <p>* Integration: GG4L</p> | |

Communications

| Platform | |
|--|---|
| <p><input checked="" type="checkbox"/> TEACHER COMMUNICATION</p> | <p><input checked="" type="checkbox"/> MASS NOTIFICATIONS</p> |
| <p>* Communications Core (Messages) View a detailed description of what is included in your software package here https://www.finalsite.com/ssu Usage Plan: https://www.finalsite.com/mxr-usage-plan</p> | |
| Add-Ons | |
| <p>* Workflows</p> | |

| Products Included in Communications Core | |
|--|-------------------------|
| Unlimited Email Messages | Staff / Faculty Profile |
| Google Translate | Base Integrations |

| | |
|-------------------|----------------------|
| Finalsite Central | Roles & Permissions |
| Directories | Standard SSO |
| Constituents | MFA / Authentication |
| Parent Profile | 24/7 Support |
| Student Profile | Resource Manager |

The above products, to include but not limited to (modules, integration, design and consulting) will be billed upon contract signature.

Application Services Subscriptions Costs:

Total Cost/Year during the Initial Term of this Order, subject to adjustment for any renewal term as provided below.

| |
|-------------------------------|
| Total Setup Cost (USD) |
| \$ 0 |

| Schedule | Addendum Amount |
|------------------------|------------------------|
| Period 1 - Sep 01 2024 | \$ 0 |
| Period 2 - Sep 01 2025 | \$ 0 |
| Period 3 - Sep 01 2026 | \$ 0 |
| Period 4 - Sep 01 2027 | \$ 0 |

B. Additional Terms

1. **Initial Term:** This addendum will take effect on the date this document is signed by both parties and remain in effect for the term stated in the agreement.
2. Unless otherwise specified in the Special Provisions above, this Order Form shall be renewed automatically for successive periods of (5) years (each a "Renewal Term") after the expiration of the Initial Term and any subsequent Renewal Term, unless Client provides Finalsite, or Finalsite provides Client, with a written notice to the contrary ninety (90) days prior to the end of the Initial Term or Renewal Term, as applicable.
3. **Effective Date:** Upon execution of this Order.
4. Finalsite standard maintenance and support is included in the subscription fees for Application Services set forth in this Order.
5. All Upgrades and Updates to the Application Services are included in the subscription fees for Application Services set forth in this Order.
6. In addition to Customer's obligations to pay the fees described in the fee table above, Customer agrees to reimburse Finalsite for all travel and other out-of-pocket expenses reasonably incurred by Finalsite in rendering any services described in this Order.

C. Payment Terms

1. All fees for the initial year of this Order shall be due upon execution of this Order. Unless otherwise specified, all dollars (\$) are United States currency. All fees for subsequent years shall be due upon the annual anniversary of the effective date of this Order.
2. Client shall be invoiced for amounts due in respect of the first year of the Initial Term upon execution of this Order Form.
3. **Sales Tax:** If applicable, a copy of your Sales Tax Direct Pay Certificate or your Sales Tax Exemption Certificate must be returned with this Order Form.

Any SOWs to which links are provided above in Section A, "Pricing Summary," are incorporated into this Order by reference, and any professional services described therein are included as part of your software package. By signing below, Finalsite and Customer each agree to the terms and conditions of this Order, the Master Terms, and any SOWs incorporated by reference. By signing below, Finalsite and Customer each agree to the terms and conditions of this Order and the Master Terms.

| |
|--|
| On Behalf Of: Lake Dallas Independent School District |
| Signature |
| Name (printed) |
| Title (printed) |
| Date |

| |
|---|
| Active Internet Technologies ('Finalsite') |
| Signature |
| Name (printed) |
| Title (printed) |
| Date |

D. Client Contact Information

Please fill out the following information, which will be used by our deployment & accounting teams.

| |
|--|
| Billing Contact |
| Title |
| Address PO Box 548 |
| City, State Zip Lake Dallas, TX 75065-0548 |
| Phone |
| Email |

| |
|------------------------|
| Project Contact |
| Title |
| Phone |
| Email |

| |
|---|
| *Executive Sponsor (Superintendent, Head of School, CFO, etc.) |
| Title |
| Email |

*The Executive Sponsor should be separate from the Project Contact and is typically the Superintendent, Head of School, Business Manager, CFO, etc.

**ADDENDUM TO AGREEMENT
BETWEEN LAKE DALLAS INDEPENDENT SCHOOL DISTRICT
AND
ACTIVE INTERNET TECHNOLOGIES, LLC, d/b/a FINALSITE**

This Addendum to Agreement ["Addendum"] is made by and between the Lake Dallas Independent School District ["LDISD or District"] and Active Internet Technologies, d/b/a Finals site ["Finals site or Provider"] who agree as follows:

1. Addendum to Agreement

LDISD and Finals site are parties to the following described Agreement ["Agreement"]:

**AGREEMENT BETWEEN LAKE DALLAS INDEPENDENT
SCHOOL DISTRICT AND FINALSITE**

The above-referenced Agreement was approved by the LDISD on April 11, 2023 and consists of the following contract documents:

- Exh. 1** Finals site Order dated 4/7/2023
- Exh. 2** Finals site Master Terms and Conditions
- Exh. 3** Statement of Work: WCM Conversion
- Exh. 4** Finals site Student Data Privacy Agreement

LDISD and Finals site agree that to the extent that the Agreement is inconsistent with the terms of this Addendum, the terms of this Addendum shall control.

I. ADDITIONAL TERMS

Additional terms applicable to this Addendum are contained in the Finals site Order dated 3/22/24, which contain software setup, addition of GG4L, Messages Unlimited, Messages: Automated Workflows and the removal of the mass notification module and consists of the following additional contract documents:

- Exh. 5** Lake Dallas Independent School District - Add GG4L Messages Workflows Remove MN and TC
- Exh. 6** Statement of Work - Software Set-up (3)

II. TERM OF CONTRACT

The initial term of this Contract shall be from 5/1/24 through 6/30/28; provided, however, this Contract may be terminated prior to the expiration of the term as provided in the Termination Section of the contract.

II. TERMINATION

1. This addendum will take effect on the date this document is signed by both parties and remain in effect from 5/1/24 through 6/30/28.
2. At the expiration of the initial term, this contract shall not automatically renew and shall end effective June 30, 2028. Finalsight is hereby given 90 day notice of termination in accordance with paragraph 12.1 of the Finalsight Master Terms and Conditions.

III. GOVERNING LAW

This Contract is made in Texas and shall be construed, interpreted, and governed by the laws of such state. The parties irrevocably consent to the sole and exclusive jurisdiction and venue of the courts of Denton County, Texas, for any action under this Contract.

Provider shall comply with Executive Order No. 11246, entitled "Equal Employment Opportunity", as amended by Executive Order No. 11375, and as supplemented in Department of Labor Regulations (41 CFR Part 60).

Certification Regarding Prohibition Against Boycotting of Israel

Provider hereby certifies that it is not a company identified on the Texas comptroller's list of companies known to have contracts with, or provide supplies or services to, a foreign organization designated as a Foreign Terrorist Organization by the U.S. Secretary of State. Provider further certifies and verifies that neither Provider, nor any affiliate, subsidiary, or parent company of Provider, if any (the "Provider Companies"), boycotts Israel, and Provider agrees that Provider and Provider Companies will not boycott Israel during the term of this Contract. For purposes of this Contract, the term "boycott" shall mean and include terminating business activities or otherwise taking any action that is intended to penalize, inflict economic harm on, or limit commercial relations with Israel, or with a person or entity doing business in Israel or in an Israeli-controlled territory.

Certification Regarding Prohibition Against Discrimination Against Firearm & Ammunition Industries

If (a) vendor is not a sole proprietorship; (b) vendor has at least ten (10) full-time employees; (c) this contract has a value of at least \$100,000 that is paid wholly or partly from public funds; (d) the contract is not excepted under TEX. GOV'T CODE § 2274.003 of SB 19 (87th leg.); and (e) governmental entity has determined that vendor is not a sole-source provider or governmental entity has not received any bids from a vendor that is able to provide this written verification, the following certification shall apply; otherwise, this certification is not required. Pursuant to TEX. GOV'T CODE Ch. 2274 of SB 19 (87th session),

the vendor hereby certifies and verifies that the company, or association, corporation, partnership, joint venture, limited partnership, limited liability partnership, or limited liability company, including a wholly owned subsidiary, majority-owned subsidiary parent company, or affiliate of these entities or associations, that exists to make a profit, does not have a practice, policy, guidance, or directive that discriminates against a firearm entity or firearm trade association and will not discriminate during the term of this contract against a firearm entity or firearm trade association. For purposes of this contract, “discriminate against a firearm entity or firearm trade association” shall mean, with respect to the entity or association, to: “(1) refuse to engage in the trade of any goods or services with the entity or association based solely on its status as a firearm entity or firearm trade association; (2) refrain from continuing an existing business relationship with the entity or association based solely on its status as a firearm entity or firearm trade association; or (3) terminate an existing business relationship with the entity or association based solely on its status as a firearm entity or firearm trade association. See TEX. GOV’T CODE § 2274.001(3) of SB 19. “Discrimination against a firearm entity or firearm trade association” does not include: “(1) the established policies of a merchant, retail seller, or platform that restrict or prohibit the listing or selling of ammunition, firearms, or firearm accessories; and (2) a company’s refusal to engage in the trade of any goods or services, decision to refrain from continuing an existing business relationship, or decision to terminate an existing business relationship to comply with federal, state, or local law, policy, or regulations or a directive by a regulatory agency, or for any traditional business reason that is specific to the customer or potential customer and not based solely on an entity’s or association’s status as a firearm entity or firearm trade association.” See TEX. GOV’T CODE § 2274.001(3) of SB 19.

Certification Regarding Prohibition Against Boycotting Certain Energy Companies

If (a) vendor is not a sole proprietorship; (b) vendor has ten (10) or more full-time employees; and (c) this contract has a value of \$100,000 or more that is to be paid wholly or partly from public funds, the following certification shall apply; otherwise, this certification is not required. Pursuant to TEX. GOV’T CODE Ch. 2274 of SB 13 (87th session), the vendor hereby certifies and verifies that the company, or any wholly owned subsidiary, majority-owned subsidiary, parent company, or affiliate of these entities or business associations, if any, does not boycott energy companies and will not boycott energy companies during the term of the contract. For purposes of this contract, the term “company” shall mean an organization, association, corporation, partnership, joint venture, limited partnership, limited liability partnership, or limited liability company, that exists to make a profit. The term “boycott energy company” shall mean “without an ordinary business purpose, refusing to deal with, terminating business activities with, or otherwise taking any action intended to penalize, inflict economic harm on, or limit commercial relations with a vendor because the vendor(a) engages in the exploration, production, utilization, transportation, sale, or manufacturing of fossil fuel-based energy and does not commit or pledge to meet environmental

standards beyond applicable federal and state law, or (b) does business with a vendor described by paragraph (a). See TEX. GOV'T CODE § 809.001(1).

2. Compensation

a. Total Setup Cost (USD) \$0

Schedule Addendum Amount

| | |
|--------------------------|------|
| Period 1 - Jul 01, 2024, | \$ 0 |
| Period 2 - Jul 01, 2025, | \$ 0 |
| Period 3 - Jul 01, 2026, | \$ 0 |
| Period 4 - Jul 01, 2027, | \$ 0 |

3. Execution of Addendum

The parties have executed this Addendum hereby amending the Agreement effective as of the date of the Agreement.

**LAKE DALLAS INDEPENDENT
SCHOOL DISTRICT**

**ACTIVE INTERNET
TECHNOLOGIES (Finalsite)**

[Name] _____ Date
[Title]

[Name] _____ Date
[Title]



LAKE DALLAS INDEPENDENT SCHOOL DISTRICT

Request for Acceptance of Donated Items

Dept/Campus Receiving Donation/Gift: Lake Dallas Elementary

Name of Donor (If organization, please include name of president)

Lake Dallas Elementary PTA | Melissa Haughton

Mailing Address

401 Main St.

City

Lake Dallas

Zip Code

75065

Description of Donation/Gift:

Eiantex Picnic Table Bench Set
for PreK Playground

Value \$ 149⁰⁰

Permission is requested to accept this donation/gift for our school/department. The donor understands that this donation/gift will become the property of the Lake Dallas Independent School District and will be under the jurisdiction of the school/department in accordance with School Board Policy and administrative rules and regulations. Approved donations/ gifts should be added to fixed asset inventory, if applicable.

Remarks:

Superintendent _____

CFO _____

Approval

Disapproval

Approval

Disapproval

Date of Approval/Disapproval _____



LAKE DALLAS INDEPENDENT SCHOOL DISTRICT

Request for Acceptance of Donated Items

Dept/Campus Receiving Donation/Gift: Lake Dallas Elementary

Name of Donor (If organization, please include name of president)

Lake Dallas Elementary PTA | Melissa Haughton

Mailing Address

401 Main St.

City

Lake Dallas

Zip Code

75065

Description of Donation/Gift:

\$20,000 to put toward fund for
LDE playground shade.

Value \$ 20,000⁰⁰

Permission is requested to accept this donation/gift for our school/department. The donor understands that this donation/gift will become the property of the Lake Dallas Independent School District and will be under the jurisdiction of the school/department in accordance with School Board Policy and administrative rules and regulations. Approved donations/ gifts should be added to fixed asset inventory, if applicable.

Remarks:

Superintendent _____

CFO _____

Approval

Disapproval

Approval

Disapproval

Date of Approval/Disapproval _____



Quote

03/28/2024

Project:

Lake Dallas ISD - Lake Dallas ES
Serving Line Replacement (RFP
022018-0023-3)
Bid



From:

Supreme Fixture Co., Inc.
Dan Pickett
2000 North Central Expressway
Plano, TX 75074
501-455-2552
214-343-0700 (Contact)

Job Reference Number: 9489

******* PLEASE NOTE: MOD-U-SERVE'S QUOTE IS NOT AN INDICATION OF COMMITTING TO THE REQUIRED COMPLETION DATE LISTED IN THE RFP. MOD-U-SERVE'S COMPLETION DATE IS DICTATED BY RECEIPT OF COMPLETE INFORMATION (PO, COLOR SELECTIONS, APPROVED DRAWINGS, ETC.) ALL PROJECTS WILL BE SUBJECT TO CURRENT LEAD TIMES AT TIME OF RECEIPT OF ABOVE MENTIONED COMPLETE INFORMATION *******

| Item | Qty | Description | Sell | Sell Total |
|------|------|--|--------------------|---------------------|
| 1 | 2 ea | MILK COOLER Mod-U-Serve Model No. MCT-DM1 Double Drop Front Milk Cooler, 34"W, dual access, (8) case capacity, mobile modular, enclosed base, hasp locking device, corner bumpers, digital temperature display, valve drain, stainless steel exterior, interior liner & doors, 5" casters (2 locking), 1/3hp, UL, NSF | \$4,498.00 | \$8,996.00 |
| | 2 ea | 1 yr. parts and labor warranty std. | | |
| | 2 ea | MC-MKMS-1 Milk Cooler Air Curtain, for 8 case capacity coolers | \$432.00 | \$864.00 |
| | | | ITEM TOTAL: | \$9,860.00 |
| | 1 ea | SERVING COUNTER Mod-U-Serve Counters Model No. MCT-SC MOD-U-SERVE CUSTOM SERVING COUNTER TO CONSIST OF: | \$197,041.00 | \$197,041.00 |
| | | | ITEM TOTAL: | \$197,041.00 |
| 2A | 2 ea | SERVING COUNTER, UTILITY | | |

| Item | Qty | Description | Sell | Sell Total |
|--|------|--|------|------------|
|  | | Mod-U-Serve Counters Model No. MCT-FT6-MOD Mobile Serving Utility Station, flat top, MODIFIED LENGTH/DEPTH/CONFIGURATION, mobile modular, open cabinet base, stainless steel sides, top & undershelf | | |
| | 2 ea | 1 yr. parts and labor warranty std. | | |
| | 2 ea | MCT-S-TRAY ENGINEERED STONE TRAYSLIDE | | |
| | 2 ea | MCT-TRAY LIGHT Bottom mount trayslide lights | | |
| | 4 ea | MCT-SILVER Silverware dispenser | | |
| | 2 ea | MCT-TILE Tile front application by Mod-U-Serve; RAISED/EXTENDED | | |
| | 2 ea | MCT-SK Skirting, stainless steel | | |
| | 2 ea | MCT-SPC Single Point Connection; TO INTERCONNECT BOX | | |
| | 2 ea | MCT-CO Cut Out, for drop-ins | | |
| | 4 ea | 1220-BM-4 DROP IN/BOTTOM MOUNT HEATED FOUR (4) WELL HOT FOOD UNIT | | |
| | 2 ea | MCT-DRN Common Drain & Manifold, for (4) wells | | |
| | 2 ea | MCT-ELITE-ADJ Stainless steel custom adjustable sneezeguard with glass breath protector and top shelf; WITH HEAT LAMP AND LIGHT | | |
| 2B | 1 ea | SERVING COUNTER, UTILITY Mod-U-Serve Counters Model No. MCT-FT2-MOD Mobile Serving Utility Station, flat top, MODIFIED LENGTH/DEPTH/CONFIGURATION, mobile modular, open cabinet base, stainless steel sides, top & undershelf | | |
|  | | | | |
| | 1 ea | 1 yr. parts and labor warranty std. | | |
| | 1 ea | MCT-SPC Single Point Connection | | |
| 2C | 1 ea | SERVING COUNTER, UTILITY Mod-U-Serve Counters Model No. MCT-FT6 Mobile Serving Utility Station, flat top, MODIFIED LENGTH/DEPTH/CONFIGURATION, mobile modular, open cabinet base, stainless steel sides, top & undershelf | | |
| | 1 ea | 1 yr. parts and labor warranty std. | | |
| | 2 ea | MCT-S-TRAY ENGINEERED STONE TRAYSLIDE | | |
| | 2 ea | MCT-TRAY LIGHT Bottom mount trayslide lights | | |
| | 2 ea | MCT-TILE Tile front application by Mod-U-Serve; RAISED/EXTENDED | | |
| | 2 ea | MCT-SK Skirting, stainless steel | | |
| | 1 ea | MCT-SPC Single Point Connection; TO INTERCONNECT BOX | | |
| | 1 ea | MCT-CO Cut Out, for drop-ins | | |
| | 1 ea | DI-CFSP-3 Drop-in recessed frost top to accommodate three (3) 18" x 26" sheet pans | | |
| | 1 ea | MCT-ELITE-ADJ *** SINGLE TIER/DUAL SERVICE *** Stainless steel custom adjustable sneezeguard with glass breath protector and top shelf; WITH LIGHT | | |

| Item | Qty | Description | Sell | Sell Total |
|------|------|---|-------------------------------------|-------------------|
| 2D | 1 ea | SERVING COUNTER, UTILITY Mod-U-Serve Counters Model No. MCT-FT6 Mobile Serving Utility Station, flat top, MODIFIED LENGTH/DEPTH/CONFIGURATION, mobile modular, open cabinet base, stainless steel sides, top & undershelf 1 ea 1 yr. parts and labor warranty std. 2 ea MCT-S-TRAY ENGINEERED STONE TRAYSLIDE 2 ea MCT-TRAY LIGHT Bottom mount trayslide lights 2 ea MCT-TILE Tile front application by Mod-U-Serve; RAISED/EXTENDED 2 ea MCT-SK Skirting, stainless steel 1 ea MCT-SPC Single Point Connection; TO INTERCONNECT BOX 2 ea MCT-SR Slanted Snack Rack, stainless steel; WITH LIGHT 2 ea MCT-CASH CASHIER SET UP TO INCLUDE LOCKING CASH DRAWER, GROMMETED OPENING AND UNDERCOUNTER OUTLET | | |
| 2E | 1 ea | UTILITY RISER Mod-U-Serve Counters Model No. MCT-EC-W Electrical/Water Chase | | |
| 3A | 1 ea | DELIVERY Mod-U-Serve Counters Model No. MCT-DELIVERY DELIVERY AND SET IN PLACE BY MOD-U-SERVE; ALL FINAL CONNECTIONS TO BE COMPLETED BY OTHERS *** PRICING IS SUBJECT TO CHANGE BASED ON JOBSITE REQUIREMENTS *** | | |
| 3B | 1 ea | INSTALLATION SERVICES Mod-U-Serve Counters Model No. MCT-TURNKEY Turnkey Installation to include: Insurance and Final Clean of work space Remove existing serving line from school and move to storage facility Cap and cover any necessary existing water lines Disconnect electrical from existing serving line and improve electrical wiring as needed for new serving line Make final connections and start up the unit Data connections and wiring to be completed by district Ceiling tiles to be provided by district as needed | | |
| 3 | | PAYMENT & PERFORMANCE BOND IF NEEDED | | |
| 3 | 1 ea | BOND Supreme Fixture Model No. PPB Payment & Performance Bond If Needed | \$1,448.00 | <Optional> |
| | | | ITEM TOTAL: <Optional> | \$1,448.00 |

Subtotal

\$206,901.00

Total

\$206,901.00

Mod-U-Serve Pricing is valid for shipment through June 2024. Shipments required after this date will be subject to repricing.

Acceptance: _____ Date: _____

Printed Name: _____

Project Grand Total: \$206,901.00

Mobile Double Drop Front Milk Cooler

Standard Features

INTERIOR LINER: 18 gauge stainless steel fully welded liner with breaker strip attachment to exterior panels.

EXTERIOR: 20 gauge stainless steel.

DOORS: 20 gauge double pan insulated doors with magnetic gasket.

INSULATION: High pressure foamed in place 2" thick polyurethane.

CASTERS: Heavy duty 5" diameter plate casters with gray rubber tires. Brake models to be supplied on all casters.

DRAIN: 1/2" stainless steel nipple fully welded to interior liner with full port valve at exterior.

CONDENSING UNIT: R-404A high temperature hermetically sealed with expansion valve and pressure switch operation.

CONDENSING UNIT HOUSING: Front and rear removable louver panels for flow through air design.

LOCKING MECHANISM: Hasp locking mechanism provided for complete cabinet security.

CORNER BUMPERS: Rubber bumpers provided on each corner.

THERMOMETER: 2 1/2" dial thermometer.

STAINLESS STEEL SPECIFICATION: All stainless steel to be type 304 with number 4 finish except door contact cap which will be magnetic type 430 stainless steel.

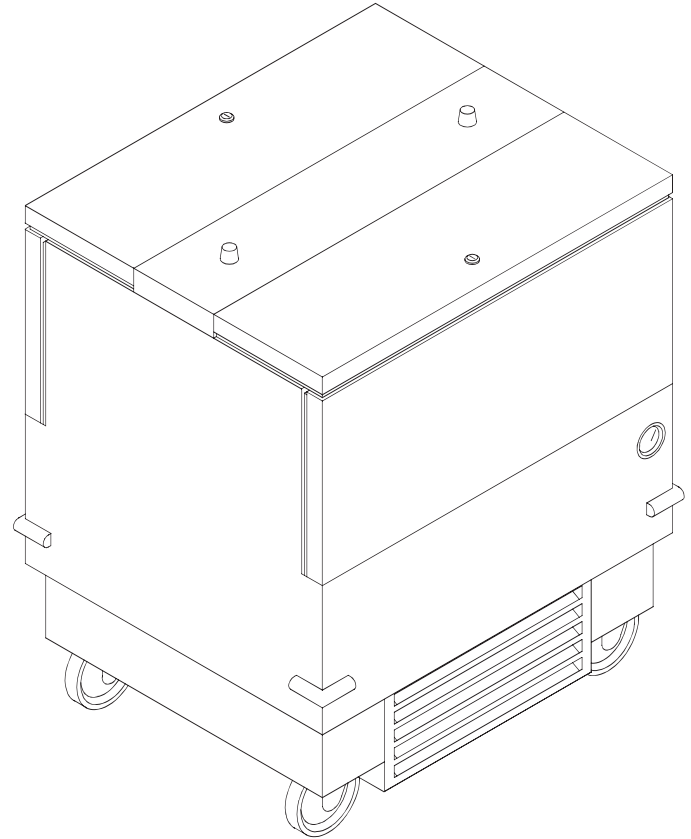

| MODEL | *CASE LENGTH | CAPACITY | HP | VOLTS | PHASE | NEMA AMPS | APPROX. CORD/CAP | SHIP WEIGHT |
|---------|--------------|----------|-----|-------|-------|-----------|------------------|-------------|
| MCT-DM1 | 34" | 8 | 1/4 | 120 | 1 | 8.0 | NEMA 5-15P | 390 lbs |
| MCT-DM2 | 49" | 12 | 1/4 | 120 | 1 | 8.0 | NEMA 5-15P | 460 lbs |
| MCT-DM3 | 64" | 16 | 1/3 | 120 | 1 | 6.0 | NEMA 5-15P | 530 lbs |

* Capacity shown is for standard 13" x 13" x 11" cases.



2320 Peyton Houston, Texas 77032
 Phone 281-442-8001 Toll Free: 888-955-5463 Fax: 281-442-3351 www.mod-u-serve.com

MUS.2 11/05

Mobile Double Drop Front Milk Cooler

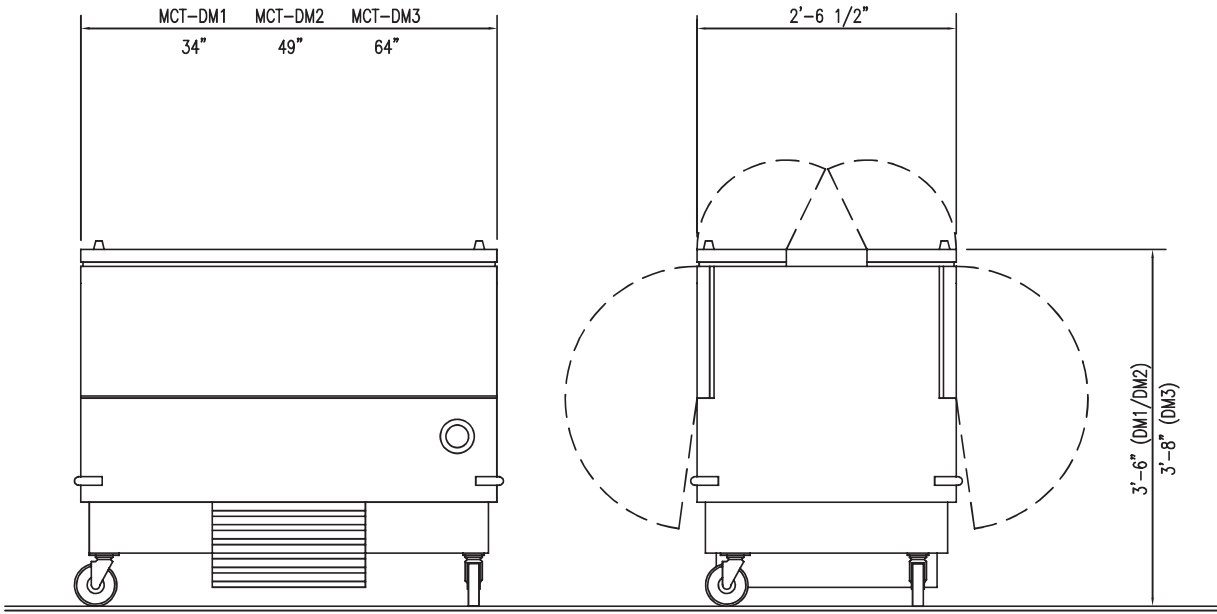

Optional Features

LEGS: 6" adjustable stainless steel legs in lieu of casters.

CASTERS: 5" stainless steel casters.

ADDITIONAL WARRANTY: Additional 12 month limited warranty on parts and labor.

CURTAINS: Milk cooler door curtains.

For options / accessories / modifications not shown, please contact factory.



Mod-U-Serve reserves the right to modify specifications or discontinue models without notice or incurring obligation.



2320 Peyton Houston, Texas 77032

Phone 281-442-8001 Toll Free: 888-955-5463 Fax: 281-442-3351 www.mod-u-serve.com

MUS.2 11/05

Mobile Flat Top Counter

Standard Features

FRAME: Featuring frameless construction utilizing 16 gauge stainless steel end panels with top and bottom horizontal members of 16 gauge stainless steel.

CASTERS: Heavy duty 5" diameter plate casters with gray rubber tires. Brake models to be supplied on all casters.

TOP: 14 gauge stainless steel with 2" turndown on all sides and sound deadening applied between top and frame.

FRONT BODY PANEL: Removable stainless steel or plastic laminate front panel.

UNDERSHELF: 18 gauge stainless steel with 18" high ends and 4" high back. Undershelf is held back 6" from front panel forming a utility chase for plumbing and electrical services.

FRONT BODY PANEL: Removable stainless steel or plastic laminate front panel.

STAINLESS STEEL SPECIFICATION: All stainless steel to be type 304 with number 4 finish.

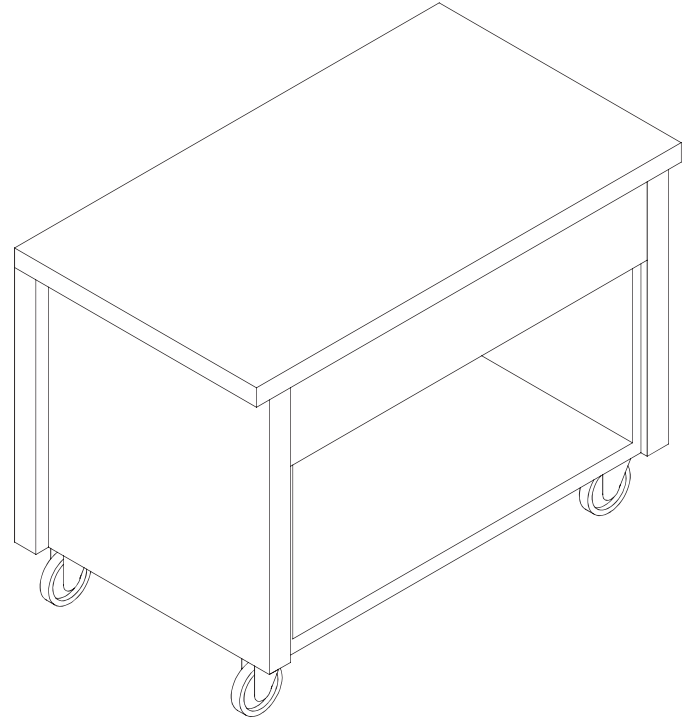

| MODEL | LENGTH | APPROX. SHIP WEIGHT |
|---------|--------|---------------------|
| MCT-FT2 | 36" | 275 lbs |
| MCT-FT3 | 50" | 330 lbs |
| MCT-FT4 | 64" | 390 lbs |
| MCT-FT5 | 78" | 460 lbs |
| MCT-FT6 | 92" | 520 lbs |



2320 Peyton Houston, Texas 77032

Phone 281-442-8001 Toll Free: 888-955-5463 Fax: 281-442-3351 www.mod-u-serve.com

MUS.14 11/05

Mobile Flat Top Counter

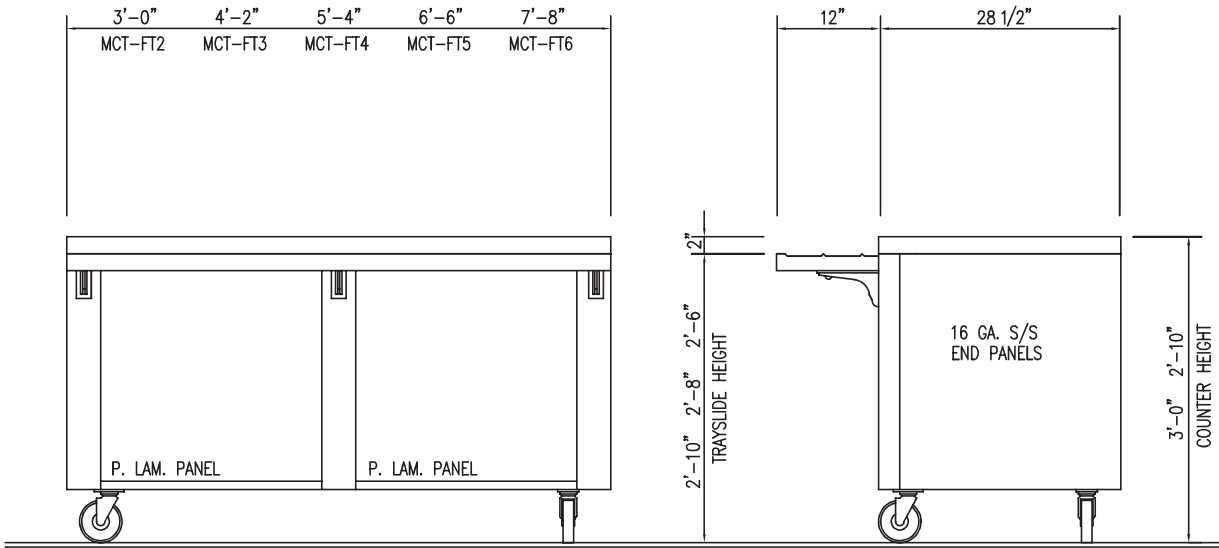

Optional Features

FRONT BODY PANEL: Ceramic tile front panel.

TRAYSLIDE: Stainless steel or Corian® trayslide mounted on fold down brackets. Stainless steel tubular trayslide also available, on fold down brackets.

WORKSHELF: 16 gauge stainless steel 8" wide shelf mounted at rear on fold down brackets.

PLATESHELF: 16 gauge stainless steel 8" wide shelf mounted at rear on fold down brackets

FLUORESCENT LIGHT: Pre-wired fluorescent light fixture with safety shields and toggle switch.

ADDITIONAL WARRANTY: Additional 12 month limited warranty on parts and labor.

SERVING SHELF: 16 gauge stainless steel or Corian® single serve with 1 1/2" turndown on all sides. Support post of 1 1/4" 18 gauge stainless. Includes sneezeguard of 3/8" thick high grade Lexan® with polished edges.

DISPLAY SHELF: 16 gauge stainless steel or Corian® two-tier shelf with 1 1/2" turndown on all sides. Support post of 1 1/4" 18 gauge stainless. Includes sneezeguard of 3/8" thick high grade Lexan® with polished edges.

BUFFET SERVICE: Dual service shelf with dual service sneezeguard of 3/8" thick high grade Lexan® with polished edges.

OPTIONAL COUNTER/TRAYSLIDE HEIGHT:
 Elementary schools – 34" counter / 30" trayslide
 Middle School – 34" counter / 32" trayslide
 High School – 36" counter / 34" trayslide

For options / accessories / modifications not shown, please contact factory.

Mod-U-Serve reserves the right to modify specifications or discontinue models without notice or incurring obligation.



2320 Peyton Houston, Texas 77032

Phone 281-442-8001 Toll Free: 888-955-5463 Fax: 281-442-3351 www.mod-u-serve.com

MUS.14 11/05

Mobile Flat Top Counter

Standard Features

FRAME: Featuring frameless construction utilizing 16 gauge stainless steel formed end panels with top and bottom horizontal members of 16 gauge stainless steel.

CASTERS: Heavy duty 5" diameter plate casters with gray rubber tires. Brake models to be supplied on all casters.

TOP: 14 gauge stainless steel with 2" turndown on all sides and sound deadening applied between top and frame.

FRONT BODY PANEL: Removable stainless steel or plastic laminate front panel.

UNDERSHELF: 18 gauge stainless steel with 18" high ends and 4" high back. Undershelf is held back 6" from front panel forming a utility chase for plumbing and electrical services.

FRONT BODY PANEL: Removable stainless steel or plastic laminate front panel.

STAINLESS STEEL SPECIFICATION: All stainless steel to be type 304 with number 4 finish.

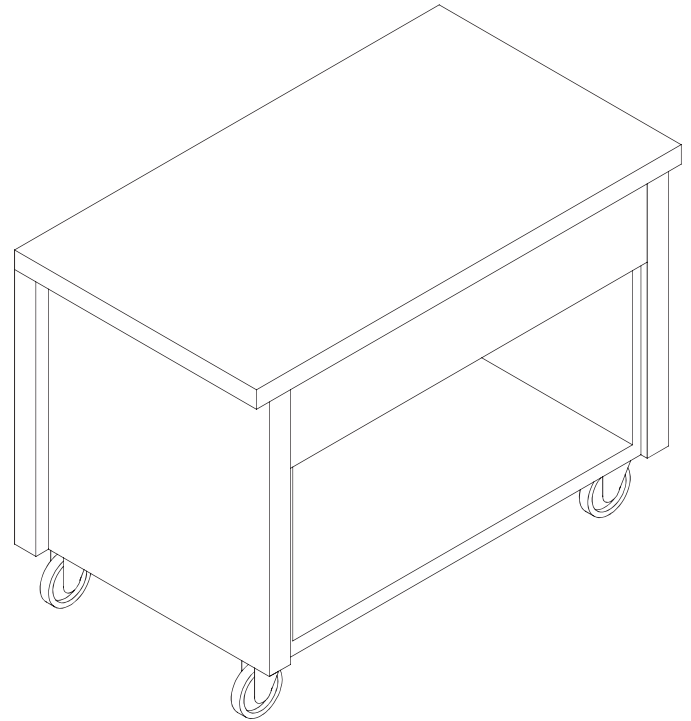

| MODEL | LENGTH | APPROX. SHIP WEIGHT |
|---------|--------|---------------------|
| MCT-FT2 | 36" | 275 lbs |
| MCT-FT3 | 50" | 330 lbs |
| MCT-FT4 | 64" | 390 lbs |
| MCT-FT5 | 78" | 460 lbs |
| MCT-FT6 | 92" | 520 lbs |



2320 Peyton Houston, Texas 77032
 Phone 281-442-8001 Toll Free: 888-955-5463 Fax: 281-442-3351 www.mod-u-serve.com

MUS.14 11/05

Mobile Flat Top Counter

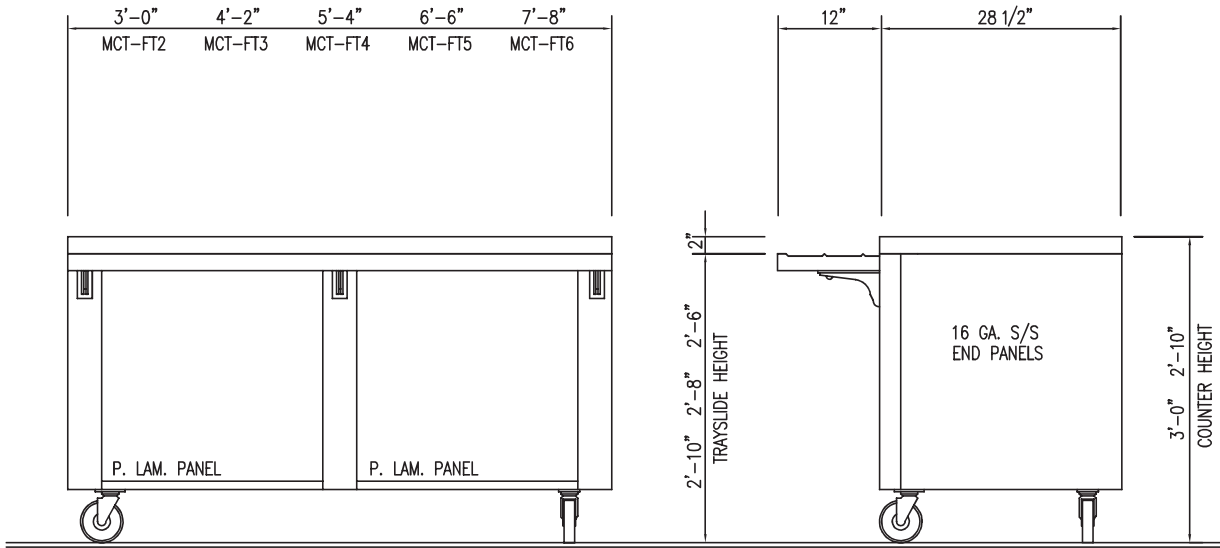

Optional Features

FRONT BODY PANEL: Ceramic tile front panel.

TRAYSLIDE: Stainless steel or Corian® trayslide mounted on fold down brackets. Stainless steel tubular trayslide also available, on fold down brackets.

WORKSHELF: 16 gauge stainless steel 8" wide shelf mounted at rear on fold down brackets.

PLATESHELF: 16 gauge stainless steel 8" wide shelf mounted at rear on fold down brackets

FLUORESCENT LIGHT: Pre-wired fluorescent light fixture with safety shields and toggle switch.

ADDITIONAL WARRANTY: Additional 12 month limited warranty on parts and labor.

SERVING SHELF: 16 gauge stainless steel or Corian® single serve with 1 1/2" turndown on all sides. Support post of 1 1/4" 18 gauge stainless. Includes sneezeguard of 3/8" thick high grade Lexan® with polished edges.

DISPLAY SHELF: 16 gauge stainless steel or Corian® two-tier shelf with 1 1/2" turndown on all sides. Support post of 1 1/4" 18 gauge stainless. Includes sneezeguard of 3/8" thick high grade Lexan® with polished edges.

BUFFET SERVICE: Dual service shelf with dual service sneezeguard of 3/8" thick high grade Lexan® with polished edges.

OPTIONAL COUNTER/TRAYSLIDE HEIGHT:
 Elementary schools – 34" counter / 30" trayslide
 Middle School – 34" counter / 32" trayslide
 High School – 36" counter / 34" trayslide

For options / accessories / modifications not shown, please contact factory.

Mod-U-Serve reserves the right to modify specifications or discontinue models without notice or incurring obligation.



2320 Peyton Houston, Texas 77032

Phone 281-442-8001 Toll Free: 888-955-5463 Fax: 281-442-3351 www.mod-u-serve.com

MUS.14 11/05

| Supreme Fixture Co. | | |
|---|-------------------|---------------------|
| Evaluation Criteria | Max Points | Vendor Score |
| Vendor Cost 206,901.00 | 60 | 58 |
| Reasonable and Responsive Bidder (all documents submitted as required and with accuracy and financial health of company is confirmed) | 10 | 10 |
| The quality of the vendor's good(s); if unknown, samples will be requested and compared; | 10 | 10 |
| The extent to which the goods or services meet Lak | 10 | 10 |
| Reputation of Vendor and Vendor goods/services per reference feedback and/or personal experience | 4 | 4 |
| Qualifies as HUB, Minority, Woman-Owned, Small or Veteran-Owned Business | 1 | 1 |
| Any other relevant factor that Lake Dallas ISd would consider in selecting a vendor (i.e. Quality of services offered, easy to contact, prompt responses if known. If unknown, company references will be considered.. Availability of products if known. If unknown, company references will be considered.) | 5 | 5 |
| TOTAL SCORE | 100 | 98 |

RFP 022018-0023 LDE SERVING LINE

| ACE MART | | |
|---|-------------------|---------------------|
| Evaluation Criteria | Max Points | Vendor Score |
| Vendor Cost 206,901.31 | 60 | 56 |
| Reasonable and Responsive Bidder (all documents submitted as required and with accuracy and financial health of company is confirmed) | 10 | 10 |
| The quality of the vendor's good(s); if unknown, samples will be requested and compared; | 10 | 10 |
| The extent to which the goods or services meet Lak | 10 | 10 |
| Reputation of Vendor and Vendor goods/services per reference feedback and/or personal experience | 4 | 4 |
| Qualifies as HUB, Minority, Woman-Owned, Small or Veteran-Owned Business | 1 | 0 |
| Any other relevant factor that Lake Dallas ISd would consider in selecting a vendor (i.e. Quality of services offered, easy to contact, prompt responses if known. If unknown, company references will be considered.. Availability of products if known. If unknown, company references will be considered.) | 5 | 5 |
| TOTAL SCORE | 100 | 95 |

| Misson | | |
|---|-------------------|---------------------|
| Evaluation Criteria | Max Points | Vendor Score |
| Vendor Cost 210,019.00 | 60 | 54 |
| Reasonable and Responsive Bidder (all documents submitted as required and with accuracy and financial health of company is confirmed) | 10 | 10 |
| The quality of the vendor's good(s); if unknown, samples will be requested and compared; | 10 | 10 |
| The extent to which the goods or services meet Lak | 10 | 10 |
| Reputation of Vendor and Vendor goods/services per reference feedback and/or personal experience | 4 | 4 |
| Qualifies as HUB, Minority, Woman-Owned, Small or Veteran-Owned Business | 1 | 0 |
| Any other relevant factor that Lake Dallas ISd would consider in selecting a vendor (i.e. Quality of services offered, easy to contact, prompt responses if known. If unknown, company references will be considered.. Availability of products if known. If unknown, company references will be considered.) | 5 | 5 |
| TOTAL SCORE | 100 | 93 |

| Strategic Equipment LLC-Submitted late bid | | |
|---|------------|--------------|
| Evaluation Criteria | Max Points | Vendor Score |
| Vendor Cost 185,876.88 | 60 | 0 |
| Reasonable and Responsive Bidder (all documents submitted as required and with accuracy and financial health of company is confirmed) | 10 | 0 |
| The quality of the vendor's good(s); if unknown, samples will be requested and compared; | 10 | 0 |
| The extent to which the goods or services meet Lak | 10 | 0 |
| Reputation of Vendor and Vendor goods/services per reference feedback and/or personal experience | 4 | 0 |
| Qualifies as HUB, Minority, Woman-Owned, Small or Veteran-Owned Business | 1 | 0 |
| Any other relevant factor that Lake Dallas ISd would consider in selecting a vendor (i.e. Quality of services offered, easy to contact, prompt responses if known. If unknown, company references will be considered.. Availability of products if known. If unknown, company references will be considered.) | 5 | 0 |
| TOTAL SCORE | 100 | 0 |
| Pasco | | |
| Evaluation Criteria | Max Points | Vendor Score |
| Vendor Cost 218,345.00 | 60 | 52 |
| Reasonable and Responsive Bidder (all documents submitted as required and with accuracy and financial health of company is confirmed) | 10 | 10 |
| The quality of the vendor's good(s); if unknown, samples will be requested and compared; | 10 | 10 |
| The extent to which the goods or services meet Lak | 10 | 10 |
| Reputation of Vendor and Vendor goods/services per reference feedback and/or personal experience | 4 | 4 |
| Qualifies as HUB, Minority, Woman-Owned, Small or Veteran-Owned Business | 1 | 1 |
| Any other relevant factor that Lake Dallas ISd would consider in selecting a vendor (i.e. Quality of services offered, easy to contact, prompt responses if known. If unknown, company references will be considered.. Availability of products if known. If unknown, company references will be considered.) | 5 | 5 |
| TOTAL SCORE | 100 | 92 |



STUDENT SUCCESS



PARENT & FAMILY/
COMMUNITY SUPPORT



FACULTY & STAFF
ENGAGEMENT



EFFICIENT OPERATIONS



GMP APPROVAL FOR PHASE NO. 2 PART 2A OF THE 2019 BOND PROJECTS

Presenter: Wes Eversole
Event: Board of Trustees
Date: April 15, 2024





STUDENT SUCCESS



PARENT & FAMILY/
COMMUNITY SUPPORT



FACULTY & STAFF
ENGAGEMENT



EFFICIENT OPERATIONS



Tennis Court & Field Renovations



STUDENT SUCCESS



PARENT & FAMILY/
COMMUNITY SUPPORT



FACULTY & STAFF
ENGAGEMENT



EFFICIENT OPERATIONS



Construction Schedule

- April 15, 2024 Board Meeting
 - **Phase 2 – Part 2A:** GMP Recommendation to the Board (tennis courts, new curb cut, band practice lot striping, and new parking lots)
- June 17, 2024 Board Meeting
 - **Phase 2 – Part 2B:** GMP Recommendation to the Board (band hall addition, theater back of house and classroom renovations, CTE classroom renovations, agriculture building renovations, new CTE building, and new CTE parking)



STUDENT SUCCESS



PARENT & FAMILY/
COMMUNITY SUPPORT



FACULTY & STAFF
ENGAGEMENT



EFFICIENT OPERATIONS



Construction Schedule

August 2024

- Completion of Phase 1
- Completion of Phase 2A

October 2024

- Completion of Tennis Courts

June 2025

- Completion of the CATE Building

August 2025

- Completion of Phase 2



STUDENT SUCCESS



PARENT & FAMILY/
COMMUNITY SUPPORT



FACULTY & STAFF
ENGAGEMENT



EFFICIENT OPERATIONS



CTE Building

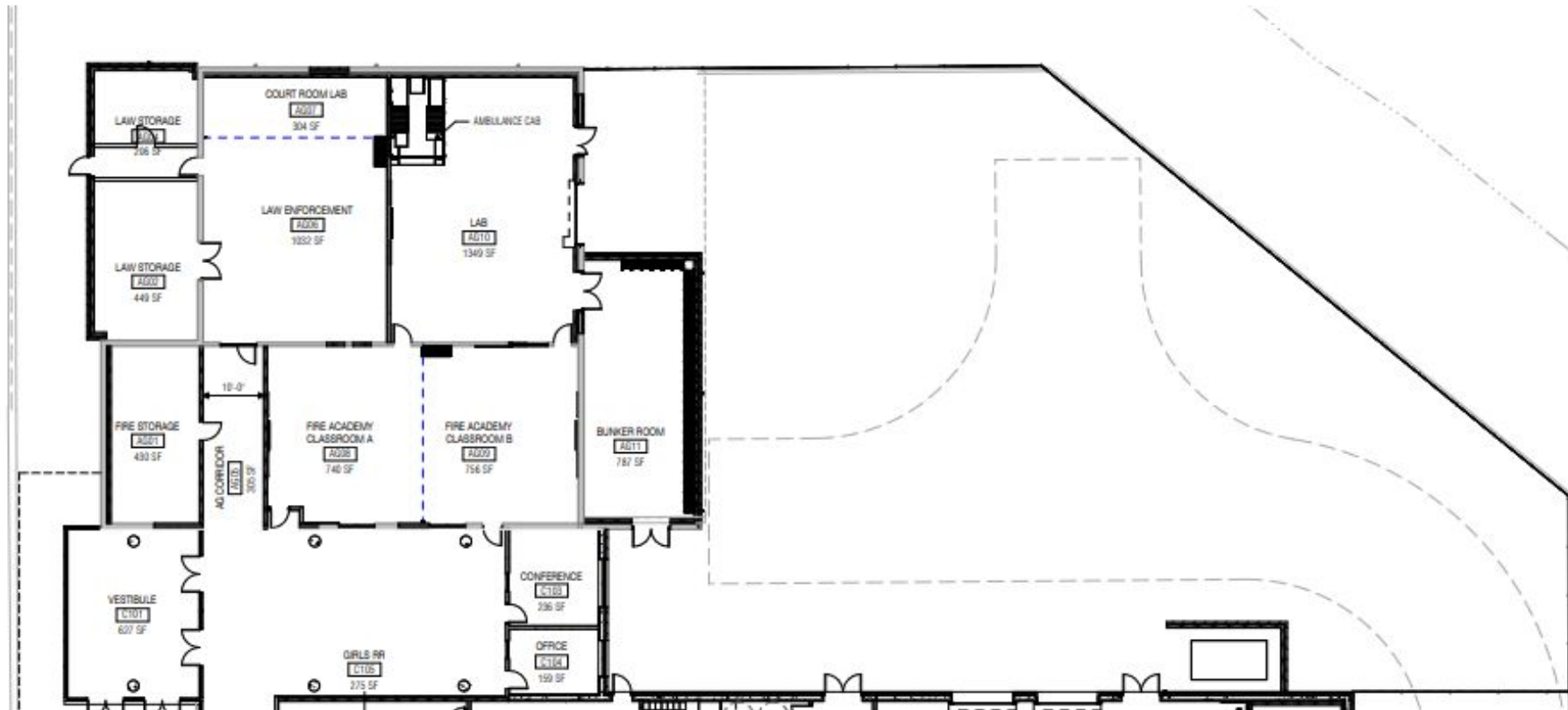

STUDENT SUCCESS



PARENT & FAMILY/
COMMUNITY SUPPORT



FACULTY & STAFF
ENGAGEMENT



EFFICIENT OPERATIONS



CTE Building



STUDENT SUCCESS



PARENT & FAMILY/
COMMUNITY SUPPORT



FACULTY & STAFF
ENGAGEMENT



EFFICIENT OPERATIONS



CONSTRUCTION GUARANTEED MAXIMUM PRICE - PHASE 2: PART 2A

LDHS

Project: Phase 2- Part2A (Tennis, Band & Civil)
Date: April 9, 2024



| Bid Package | Description | Phase 2- Part 2A (Tennis, Band, Site) | TOTAL |
|------------------------------|---|---------------------------------------|--------------|
| 01A | General Requirements - Job Expenditures | | \$ - |
| 01B | General Conditions - CM Staff | | \$ - |
| 01C | Materials Testing - BY OWNER | | \$ - |
| 31A | Earthwork | \$ 630,883 | \$ 630,883 |
| 31B | Erosion Control | \$ 22,545 | \$ 22,545 |
| 32A | Landscaping & Irrigation | \$ 117,744 | \$ 117,744 |
| 32E | Pavement Markings | \$ 24,337 | \$ 24,337 |
| 32F | Fencing & Gates | \$ 37,933 | \$ 37,933 |
| 32G | Tennis Courts | \$ 1,081,294 | \$ 1,081,294 |
| 33A | Site Utilities- Not Required | | \$ - |
| 03A | Cast-in-Place Concrete | \$ 511,885 | \$ 511,885 |
| 04B | Dumpster Enclosure ALLOWANCE | \$ 63,500 | \$ 63,500 |
| 04C | Tennis Storage Shed | \$ 50,000 | \$ 50,000 |
| 07B | Waterproofing | \$ 10,700 | \$ 10,700 |
| 13A | Bleacher (Relocate) By Owner | | \$ - |
| 13B | Band Tower | \$ 92,000 | \$ 92,000 |
| 22A | Plumbing | \$ 31,000 | \$ 31,000 |
| 26A | Electrical | \$ 359,040 | \$ 359,040 |
| SUBTOTAL DIRECT COST OF WORK | | \$ 3,032,861 | \$ 3,032,861 |

| | | | |
|--|--------------|--------------|--|
| Market Risk/ Inflation Contingency | | | |
| Design/ Estimating Contingency | | | |
| CM Contingency | \$ 107,131 | \$ 107,131 | |
| Scheduled Allowances | | | |
| Allowance No. 1: Allow for the lump sum of \$20,000.00 for changes requested by the Owner related to TAS accessibility requirements. | \$ 20,000 | \$ 20,000 | |
| Allowance No. 2: Allow for the lump sum of 5% of the Construction Cost for Owner's Contingency for changes requested by the Owner | \$ 178,551 | \$ 178,551 | |
| Allowance No. 3: Allow for the lump sum of \$25,000.00 for the purchase, delivery, and installation of room identification signs.* | \$ 25,000 | \$ 25,000 | |
| Building Permit & Plan Review Fees | | | |
| Buildier's Risk Insurance | \$ 9,776 | \$ 9,776 | |
| GL Insurance & Safety | \$ 25,637 | \$ 25,637 | |
| Payment & Performance Bond - Crossland | \$ 29,911 | \$ 29,911 | |
| Payment & Performance Bond - Subcontractor | \$ - | \$ - | |
| Preconstruction Phase Fee | \$ 8,333 | \$ 8,333 | |
| Construction Phase Fee | \$ 133,803 | \$ 133,803 | |
| | \$ 3,571,003 | \$ 3,571,003 | |



STUDENT SUCCESS



PARENT & FAMILY/
COMMUNITY SUPPORT



FACULTY & STAFF
ENGAGEMENT



EFFICIENT OPERATIONS

Recommended Phase 2: Part 2A GMP \$3,571,003





STUDENT SUCCESS



PARENT & FAMILY/
COMMUNITY SUPPORT



FACULTY & STAFF
ENGAGEMENT



EFFICIENT OPERATIONS

Any Questions?





STUDENT SUCCESS



PARENT & FAMILY/
COMMUNITY SUPPORT



FACULTY & STAFF
ENGAGEMENT



EFFICIENT OPERATIONS

LAKE DALLAS

Independent School District



April 15-May 13, 2024



UPCOMING EVENTS

Lake Dallas Independent School District

| EVENT | DATE | TIME | LOCATION |
|--|-------|----------|---|
| April | | | |
| LDHS Boys Golf @ Region 1 Tournament | 15 | | Hillcrest Country Club |
| LDISD February Board of Trustees Meeting | 15 | 5:30 PM | LDISD Central Services |
| NHS Induction Ceremony | 17 | 5:30 PM | LDHS Lecture Hall |
| NJHS Induction Ceremony | 16 | 6:00 PM | LDMS Cafeteria |
| LDHS Girls Golf @ Region 1 Tournament | 17-18 | | Lake Ridge Country Club |
| Falcon Friends Track Meet | 18 | 9:00 AM | Falcon Stadium |
| HS Softball vs Denton (Senior Night) | 18 | 6:00 PM | LDHS Fields |
| LDHS Track @ 5A Region Meet | 19 | | Lowery Fields at Plains Capital Park, Lubbock |
| LDISD Realtors' Lunch | 19 | 11:30 AM | Central Services |
| HS Baseball vs Denton | 19 | 7:00 PM | LDHS Fields |
| HS Baseball vs The Colony | 20 | 12:00 PM | LDHS Fields |
| Region 2 UIL Concert and Sightreading | 23 | | Hebron High School |
| HS Baseball vs Birdville HS | 25 | 7:00 PM | LDHS Fields |
| LDE 1st Grade Open House and Music Program | 25 | 6:30 PM | Lake Dallas Elementary |
| Thespian Induction | 25 | 7:00 PM | LDHS Performance Hall |
| LDE Purple Up! for Military Kids | 26 | | Lake Dallas Elementary |
| LD Police Kids N' Cops Safety Event and Cook Out | 27 | 11:00 AM | Lake Dallas City Hall |
| LDE Folklorico Performance | 30 | 6:00 PM | LDE Gym |
| SSE Kindergarten Open House & Program | 30 | 6:00 PM | Shady Shores Elementary |

| May | | | |
|---|----|------------|--------------------------|
| Teacher and Employee of the Month Breakfast | 2 | 8:30 AM | Central Services |
| Communities in Schools Senior Celebration | 2 | 12:30 PM | LDHS Lecture Hall |
| PK & Kinder Registration | 2 | 4:00 PM | LDE Cafeteria |
| LDMS Art Show | 2 | 5:30 PM | LDMS Main Hall & Library |
| LDMS Theatre Presents <i>Fast Food</i> | 2 | 6:30 PM | LDMS Cafeteria |
| Falcon Band Banquet | 4 | 5:00 PM | Circle R Ranch |
| Board Workshop | 6 | 5:30 PM | Central Services |
| LDE Kindergarten Open House & Program | 7 | 6:30 PM | Lake Dallas Elementary |
| LDHS Spring Choir Concert | 7 | 7:00 PM | LDHS Performance Hall |
| Military Signing Day | 8 | 9:30 AM | LDHS Foyer |
| LDHS Academic Banquet | 8 | 6:00 PM | LDHS Cafeteria |
| SSE 5th Grade Wax Musuem | 9 | 8:30 AM | Shady Shores Elementary |
| Starlight Scenes | 9 | 6:00 PM | LDHS Performance Hall |
| CE Kindergarten Open House & Program | 9 | 6:00 PM | Corinth Elementary |
| LDE Talent Show | 9 | 6:30 PM | LDE Cafeteria |
| Spring Student Showcase | 11 | 9 AM-12 PM | Lake Dallas High School |
| 5th Grade Soaring Falcons Science Symposium | 13 | 10:00 AM | Corinth Elementary |
| LDE Elementary Choir and LDMS Choir Performance | 13 | 6:30 PM | LDHS Performance Hall |
| LDISD Board of Trustees Meeting | 15 | 5:30 PM | LDISD Central Services |