

**Medina Valley Independent School District
Board of Trustees
Regular Meeting on Monday, February 26, 2024 at 6:00 PM.
Medina Valley ISD Central Office Board Room**

A Regular Board Meeting of the MVISD Board of Trustees was held on Monday, February 26, 2024, beginning at 6:00 PM at/on Medina Valley ISD Central Office Board Room.

I. First Order of Business	
A Call Meeting to Order	
B Establish a Quorum	
C Pledge of Allegiance to the Flag followed by a moment of silence	
II. Public Hearing on the Texas Academic Performance Report (TAPR)	3
A Receive Public Comments on the Texas Academic Performance Report (TAPR)	
III. Student/Staff Recognition	
A Star Students	26
B Above & Beyond Service Staff Recognition	27
C Career and Technical Education Recognition	
IV. Public Comment	28
<i>At Regular Board Meetings the Board shall permit public comment on any topic. At all other Board Meetings public comments will be limited to items on the agenda posted with the notice of the meeting. All Public Comments are limited to 5 minutes.</i>	
V. Announcements/Communications/Presentations	
A Elementary Attendance Zone Presentation	29
B Board Committee Reports	
• Finance & Operations Committee	
• Construction Committee	
• Curriculum Committee	
C Construction Briefing	35
• Silos Elementary Project	
• High School #2 Project	
• Medina Valley High School Stadium Turf Project	
D Financial Briefing	50
• General Fund Financial Statement	
• Child Nutrition Financial Statement	
• Debt Service Fund Financial Statement	
• Bond 2023 Capital Projects Report	
• Quarterly Investment Report	
E Medina Valley ISD's Scorecard, Priority #1 Update	55
F First Reading for District Initiated Revisions to Local Policies FFA, FMH, and EI	77
G Superintendent Briefing	83
• Student Achievements	
• Staff Achievements	
• District Enrollment Numbers	
VI. Discussion and Possible Action Items	
A Consider Approval of Minutes for Regular Board Meeting on January 22, 2024, and Special Board Meetings on January 22, 2024, and February 7, 2024	96
B Consider Approval of Bus Purchases	103
C Consider Approval of Purchase of Uniforms for The Middle School 's Athletic Program	196
D Consider Approval of Band Instrument Purchases	205
E Consider Approval of Medina Valley Middle School Cafeteria Seating Purchase	212
F Consider Approving the Selection of Zayo Inc. for Wide Area Network Fiber Construction and Service	216
G Consider Approval of Budget Amendment	229
H Consider Approving Selection of an Engineering Firm for the Medina Valley High School Portable Infrastructure Design Services	231
I Consider Approval of Modifications to the Employment Contract Forms beginning in the 2024-2025 School Year	240
J Consider Adoption of Resolution related to SB 763	259
K Consider Adoption of the Medina Valley ISD Good Governance Handbook	261
L Consider Acceptance of Certification of Unopposed Candidate for Single Member District #2	270
M Consider Adoption of Order to Cancel the May 4, 2024 Trustee Election for Single Member District #1, which did not Receive any Candidates, and Single Member District #2 which Received one Candidate	272
VII. Closed Session	1

A Considering the deployment, specific occasions for, or implementation of, security personnel or devices (TX Govt. Code Section 551.076)

B Personnel Matters: Resignations, Retirements, Leaves of Absence, Reassignments, New Employment, New Personnel Position, Duties/Responsibilities of Employees (TX Govt. Code Section 551.074)

VIII. Continued Discussion and Possible Action Items

A Consideration of future meeting dates

IX. Adjournment

(Items do not have to be taken in the same order as shown on the meeting agenda.)



Medina Valley

INDEPENDENT SCHOOL DISTRICT

2022-2023 DISTRICT ANNUAL REPORT
Mrs. Brandi Hendrix
Assistant Superintendent of Curriculum
and Instruction

brandi.hendrix@mvisd.org

830-931-2243

Citizenship



Responsible, respectful, trustworthy, and self-disciplined citizens who are actively engaged in their community

Communications



Can listen and read critically, speak and write articulately, communicate using advanced technologies, and adapt their communication style appropriately

Academics



Possess the necessary skills to produce quality work and be prepared for the future

Problem-Solver



Collaborative, creative, and innovative critical thinkers

Well-Rounded



Confident, goal driven, college and career ready individuals, who challenge themselves to continue to learn and grow

Table of Contents

- ❑ 2022-2023 TAPR
- ❑ Peims Financial Report 2021-2022
- ❑ Campus Performance Objectives
- ❑ Violent/Criminal Incident Report
- ❑ Postsecondary Performance of Students
- ❑ HB3 Progress
- ❑ TAPR Glossary

The logo consists of the letters 'M' and 'V' in a bold, orange, sans-serif font, positioned inside a black downward-pointing triangle.

Texas Academic Performance Report (TAPR)

2022-2023 Texas Academic Performance Report

- ❖ Compiled by the Texas Education Agency for every campus and district.
- ❖ Derived from Student Assessment Data and PEIMS Data.
- ❖ Gives viewers performance disaggregated by student demographics to include ethnicity and socioeconomic status.



Texas Academic Performance Report (TAPR)

STAAR Performance - Reported for 2023 and 2022

- Data provided for student performance in 3 performance categories
 - Approaches Grade Level
 - Meets Grade Level or Above
 - Masters Grade Level

TAPR reports for data for

- Each STAAR Assessment
- All Grades All Tested Subjects

STAAR Academic Growth*

- For 2022-2023 academic growth is calculated for
 - Reading- Grades 4-8
 - English II
 - Math - Grades 4-8
 - Algebra I

The logo consists of the letters 'MV' in a bold, orange, sans-serif font, centered within a black downward-pointing triangle.

Texas Academic Performance Report (TAPR)

2023 Accountability Rating

MVISD

The 2023 accountability reports are not yet publicly available. The release of these reports is pending judicial ruling and decisions from the 88th Legislature during a special called session.

2023 Special Education

Determination Status: No determination issued.

Distinction Designations

No designations have been issued for schools or school districts.



2022-2023 District Accreditation Status

Each year TEA places each district in one of four categories based on performance.

- Accredited
- Accredited - Warned
- Accredited- Probation
- Not accredited- Revoked

**MVISD achieved Accredited status in
2022-2023.**

Texas Academic Performance Report (TAPR)

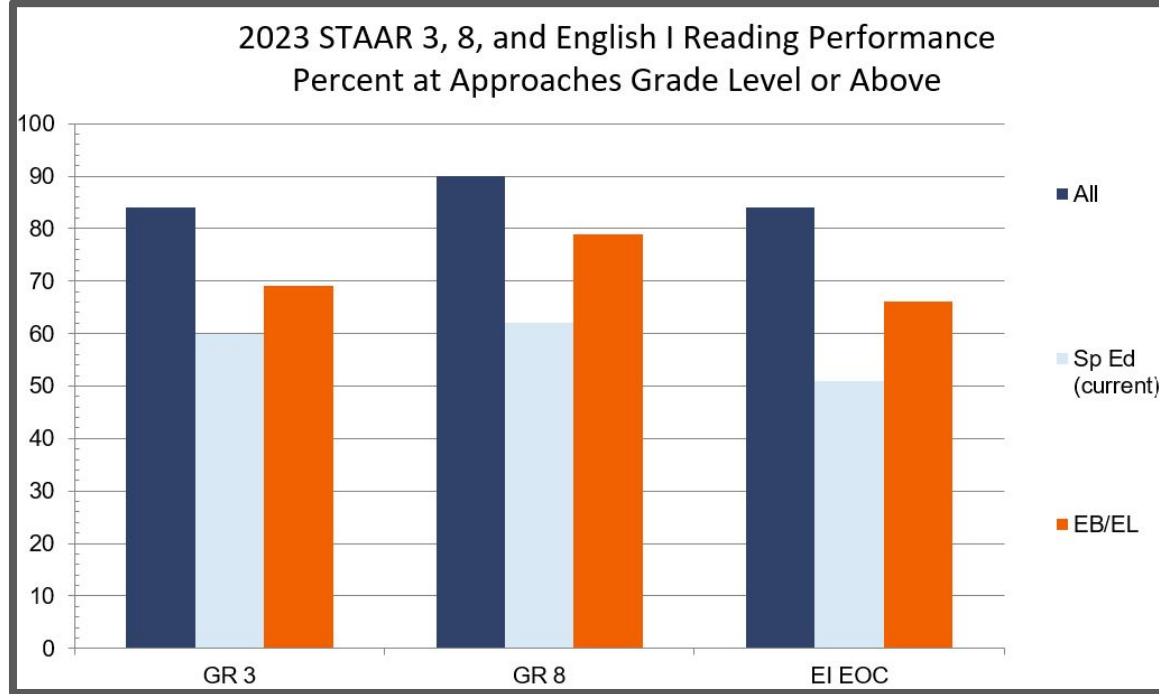



Texas Academic Performance Report (TAPR)

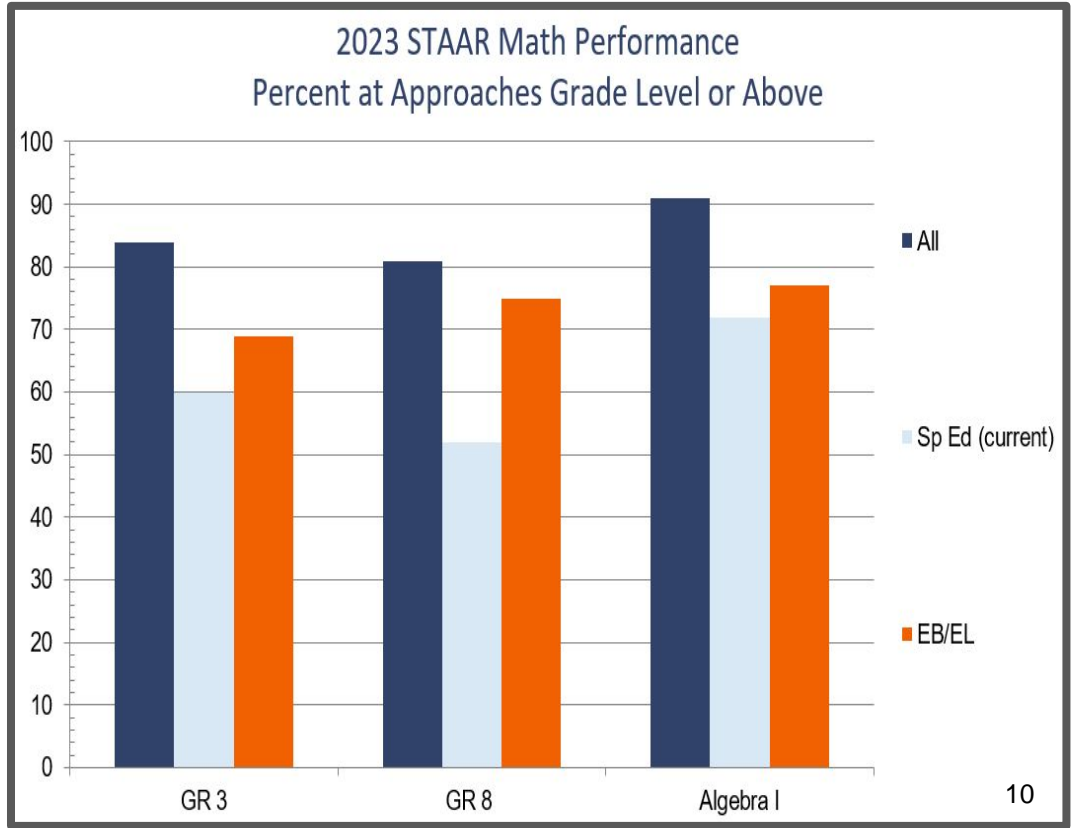



Texas Academic Performance Report (TAPR)

2022–2023 Student Demographics

	2021-22	2022-23
Economically Disadvantaged	47.8%	55.8%
Emergent Bilingual/EL	6.3%	7.2%
Section 504	9%	7.7%
At-Risk	53.2%	44.4%
Students with Dyslexia	3.5%	4.1%
Foster Care	.8%	.5%
Homeless	.6%	.6%
Military Connected	19.2%	22.2%



2022–2023 Enrollment by Program

Texas Academic Performance Report (TAPR)

	District	State
Bilingual/ESL	6.6%	23.2%
Gifted & Talented Education	6.1%	8.2%
Career and Technical Ed. (9-12)	86.4 %	72.3%
Special Education	15.2%	12.6%



2021-2022 Attendance, Graduation, and Dropout Rates

Texas Academic Performance Report (TAPR)

	District	State
Attendance Rate	93%	92.2%
Graduation Rate	98.1%	89.7%
Dropout Rate	1.9%	2.2%



Texas Academic Performance Report (TAPR)

2021-2022 CCMR

	District	State
College, Career, or Military Ready	89.4%	70%
College Ready	80.8%	52.9%
Career or Military Ready	47.2%	33.5%

Texas Academic Performance Report (TAPR)

Staff Information

- Twenty-seven percent of teaching staff hold Masters or Doctorate degrees.
- Turnover rate is 20.7%; State rate is 21.4%.

2022 – 2023 Teachers Years of Experience

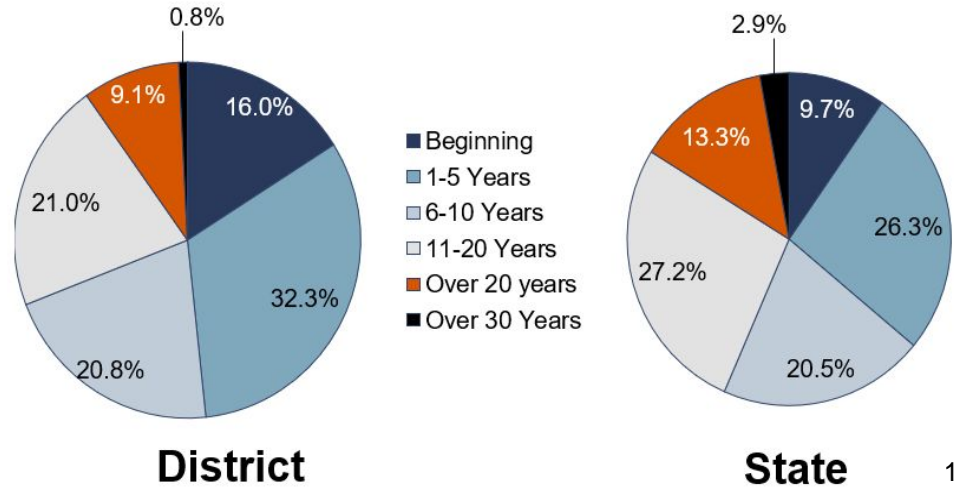



PEIMS Financial Standard Reports

[PEIMS Financial Standard Reports | Texas
Education Agency](#)

**Click the link to gain actual financial for
MVISD for:**

- Revenues
- Expenditures
- Disbursements
- Tax rates
- Fund Balance
- Campus expenditures by object,
function, and program

Campus Performance Objectives

Campus Improvement Plan (CIP)

- ❖ As Required by TEC 11.253, each campus in MVISD has developed and implemented a CIP.
- ❖ Campuses perform data analysis and needs assessment to derive performance objectives that are approved by the MVISD School Board.
- ❖ Campuses periodically measure progress towards achievement of the objectives.
- ❖ CIPs for the current school year are available on here: [Academic Accountability Reports](#).



MV

Report on Violent or Criminal Incidents

TEC Section 39.306 requires MVISD to disclose a report on violent or criminal incidents that occur at each campus in the district as part of the MVISD Annual Report.

The report must include:

- Number, rate and type of violent or criminal incidents that occurred on each campus within the district to the extent permitted via FERPA.
- Policies and procedures adopted by MVISD to ensure the prevention of school violence.



Report on Violent or Criminal Incidents

ESSA Unsafe School Choice Option (USCO) for 2021-2023 for (163908001) - MEDINA VALLEY H S

School Year (Enrollment)	Disciplinary Action Reason Codes																				Total
	11	12	13	14	16	17	18	19	29	30	31	32	36	37	46	47	48	49	57		
2022-2023 (2,318)	0 (0.00%)	0 (0.00%)	0 (0.00%)	0 (0.00%)	0 (0.00%)	0 (0.00%)	0 (0.00%)	0 (0.00%)	0 (0.00%)	0 (0.00%)	0 (0.00%)	0 (0.00%)	0 (0.00%)	0 (0.00%)	0 (0.00%)	0 (0.00%)	0 (0.00%)	0 (0.00%)	0 (0.00%)	0 (0.00%)	
2021-2022 (2,112)	0 (0.00%)	0 (0.00%)	0 (0.00%)	0 (0.00%)	0 (0.00%)	0 (0.00%)	0 (0.00%)	0 (0.00%)	0 (0.00%)	0 (0.00%)	0 (0.00%)	0 (0.00%)	0 (0.00%)	0 (0.00%)	0 (0.00%)	0 (0.00%)	0 (0.00%)	0 (0.00%)	0 (0.00%)	0 (0.00%)	
2020-2021 (1,877)	0 (0.00%)	0 (0.00%)	0 (0.00%)	0 (0.00%)	0 (0.00%)	0 (0.00%)	0 (0.00%)	0 (0.00%)	0 (0.00%)	0 (0.00%)	0 (0.00%)	0 (0.00%)	0 (0.00%)	0 (0.00%)	0 (0.00%)	0 (0.00%)	0 (0.00%)	0 (0.00%)	0 (0.00%)	0 (0.00%)	
Grand Total	0	0	0	0	0	0	0	0	0	0	0	0	0	0	0	0	0	0	0	0	

Discipline Action Reason Codes:

- 11 - Used, exhibited, or possessed a firearm
- 12 - Used, exhibited, or possessed an illegal knife
- 13 - Used, exhibited, or possessed a club
- 14 - Used, exhibited, or possessed a prohibited weapon
- 16 - Arson
- 17 - Murder, attempted murder
- 18 - Indecency with a child
- 19 - Aggravated kidnapping
- 29 - Aggravated assault on school employee
- 30 - Aggravated assault on student
- 31 - Sexual assault or aggravated sexual assault on school employee
- 32 - Sexual assault or aggravated sexual assault on student
- 36 - Felony controlled substance violation
- 37 - Felony alcohol violation
- 46 - Aggravated robbery
- 47 - Manslaughter
- 48 - Criminally negligent homicide
- 49 - Engages In Deadly Conduct
- 57 - Continuous Sexual Abuse Of Young Child(ren)



Report on Violent or Criminal Incidents

MVISD has taken the following actions, as required by TEA, prior to the start of the 2023-2024 school year:

- ❖ Conducted a summer safety audit.
- ❖ Conducted an exterior door safety audit.
- ❖ Held Safety and Security Committee meeting to review the active threat and EOP plans.
- ❖ Scheduled all safety drills for each campus for the school year 2023-2024.
- ❖ Provided training for the Threat Assessment Team.
- ❖ New Positions: Executive Director of Safety and Operations & a Director of²⁰ Health and Safety

Student Performance in Postsecondary Institutions

- ❖ TEC requires each district to publish, in the Annual Report, student performance in postsecondary institutions in the first year enrolled after graduation from high school. Data is reported by the Texas Higher Education Coordinating Board.
- ❖ The most current data available for MVISD is for 2020-2021 High School Graduates. For each student, grade points and credit hours earned during Fall 2021- Summer 2022 are added and averaged to determine GPA.



Student Performance in Postsecondary Institutions

MVISD Enrolled in Postsecondary

ALAMO CCD NW VISTA COLLEGE (000307)	44
U. OF TEXAS AT SAN ANTONIO (010115)	22
TEXAS A&M UNIVERSITY (003632)	16
TEXAS STATE UNIVERSITY (003615)	15
TARLETON STATE UNIVERSITY (003631)	8
TEXAS TECH UNIVERSITY (003644)	8
ST. MARY'S UNIVERSITY (003623)	7
ALAMO CCD ST. PHILIPS COLLEGE (003608)	5
TEXAS A&M UNIV-CORPUS CHRISTI (011161)	5
UNIV OF THE INCARNATE WORD (003578)	5
Other Pub/Ind 4-yr Institution (16)	29
Other Pub/Ind 2-yr Institution (8)	15
Not trackable	9
Not found	229
<i>Total high school graduates</i>	<i>417</i>



**MVISD District and
Campus Progress
Towards Meeting
MVISD Board
Approved HB 3
Goals**

TEC Section 39.906 requires each district to report on the progress of the district and each campus in meeting the goals approved by the board in both

- Early Childhood Literacy and Mathematics Proficiency
- CCMR Plans

**These can be accessed via the
MVISD website.**

TAPR Glossary

- ❖ Each year TEA publishes a TAPR Glossary that includes definitions, methodologies, and lists sources for each tab in the TPRS System
 - [TPRS Glossary](#)
 - [TPRS Glosario](#)



Resources and Contacts

The MVIDS TAPR is posted on the district website. In addition, paper copies are available at campuses and MVIDS Central Office. For additional information, clarification, or answers to questions, please contact:

Brandi Hendrix

Assistant Superintendent of Curriculum and
Instruction

brandi.hendrix@mvisd.org

Natalie Benke

Director of Curriculum &
Instruction & Assessment
natalie.benke@mvisd.org

Reed Trospen

Instructional Materials, Accountability
and Assessment Coordinator
reed.trospen@mvisd.org



A gray scroll graphic with a white text message. The scroll is unrolled, showing the text in the center. The top and bottom edges of the scroll are rounded, and there are small circular details on the left side suggesting the scroll's binding.

**Thank you for your
Above & Beyond
Service!**

Public Comments



Medina Valley
INDEPENDENT SCHOOL DISTRICT

**2024-2025 ELEMENTARY
ATTENDANCE ZONES**

WHY ARE NEW ATTENDANCE ZONES NEEDED?

Enrollment Projections

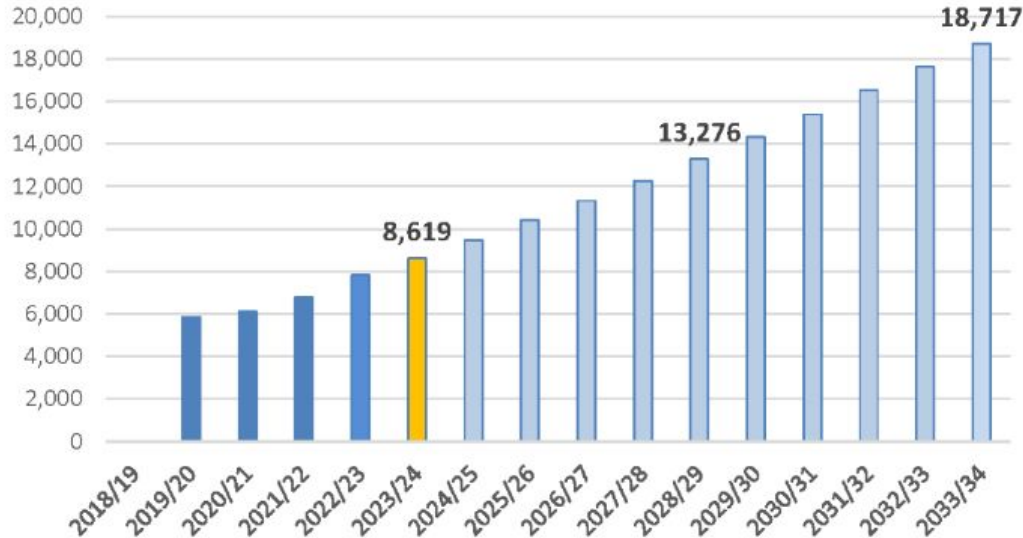

- Fast-growth school district
 - 10-15% growth each school year
 - About 800 new students in the last nine months
 - 18,000+ students projected in the next 10 years

- Silos Elementary
 - Opening Fall 2024

HOW DID WE COME TO THIS DECISION?

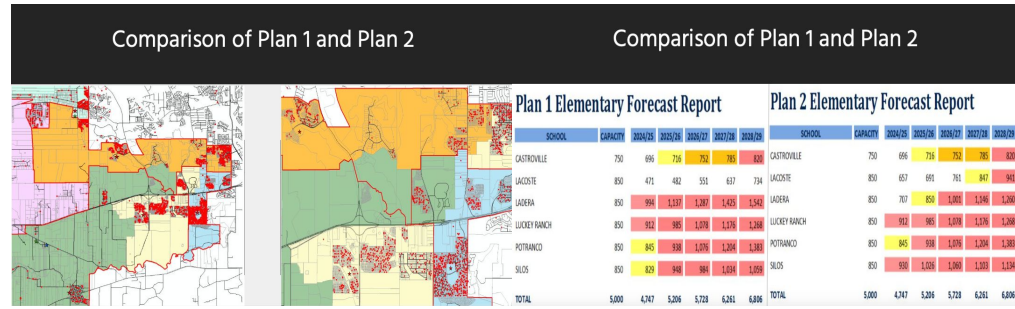
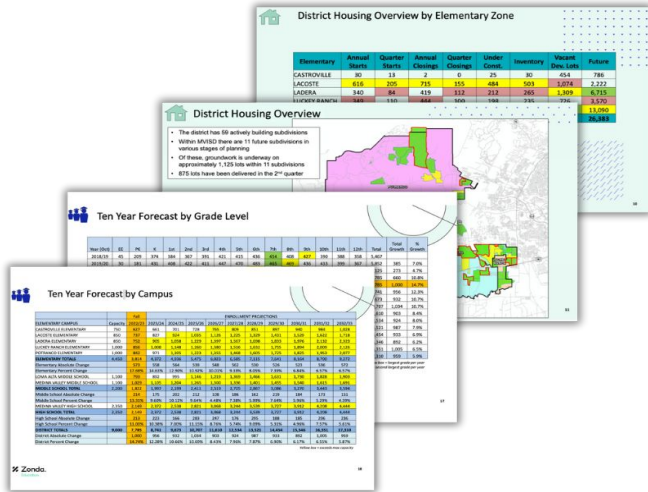

- **Demographer Reports**

Meet regularly to stay up to date with:

- Projected growth at campuses district-wide
- Current & future home construction

- **Various Scenarios**

Balance the enrollment on our campuses

Planning for the next few years, not just the 2024-25 school year



- **All students have access to safe & engaging learning environments**

2024-25 ATTENDANCE ZONES COMMUNICATION



- Families impacted were notified on ParentSquare (email & text message) on February 9, 2024

- Letters to all MVISD Parents & Staff



- Board Meetings
Email reminders, social media posts & live streamed on Youtube

TRANSFER APPLICATIONS

In-District Grandfather Transfer Form

Sent to families on ParentSquare 2/21/23

- For the 2024-25 school year, younger sibling(s) can also apply to remain on their 2023-2024 campus with their 5th-grade sibling **for one year only.**
- Transportation will not be provided for students who elect to attend a campus outside their zoned attendance boundaries.
- Following the 2024-2025 school year, the student(s) must attend their zoned campus.
- Parents must complete and submit an In-District Grandfather Transfer Form to the Office of Student Services for approval by Friday, March 1, 2024, and students must meet transfer criteria.
- Student transfers may be revoked for poor attendance, late arrivals, or misconduct. FDA (LOCAL)
- Notification of In-District Grandfather Transfer approvals will be shared with parents by March 20, 2024.

In-District Transfer Form

Available on our MVIDS website on April 8

- Please note that applying for a transfer does not guarantee approval, as the District must closely monitor enrollment numbers at each campus due to our rapid growth in student population.

WHAT CAN FAMILIES EXPECT WHEN IT COMES TO FUTURE ATTENDANCE ZONE CHANGES?

- Anytime we open a new campus, attendance zones will need to be updated to help balance enrollment
 - High School #2 - Fall 2026





**Board of Trustees Meeting:
Silos Elementary School
Construction Briefing**

GENERAL PROJECT SUMMARY:

General Contractor (CMR): _____ Nunnelly General Contractor

Original Substantial Completion Date: _____ April 2024

Requested Days to Date: _____ Zero (0)

Original Contract Sum (GMP): _____ \$42,139,608.00

Change Order Sum to Date: _____ \$0.00

Current Contract Sum: _____ \$42,139,608.00

Percentage of Work Complete: _____ 80% - Pay Application No. 17

\$33,737,082 Total Stored/Completed

RECENT CONSTRUCTION ACTIVITY

1. Site work ongoing
 - CPS made final connections and building is fully energized
 - Working on visitor drop-off deceleration lane
 - Site flatwork has started.
2. Building Exterior
 - Exterior brick is all complete minus the entrance columns
 - All of the exterior glazing is near completed throughout
 - All exterior light poles are now installed
3. Building Interior
 - Installation of high area diffuser is almost complete
 - Installation of high area lights are almost complete
 - Circuits on all outlets are being tested
 - Sinks in classrooms are being installed
 - Interior doors and hardware installation is ongoing
 - VCT flooring being installed in all areas
 - Casework is being installed in all areas

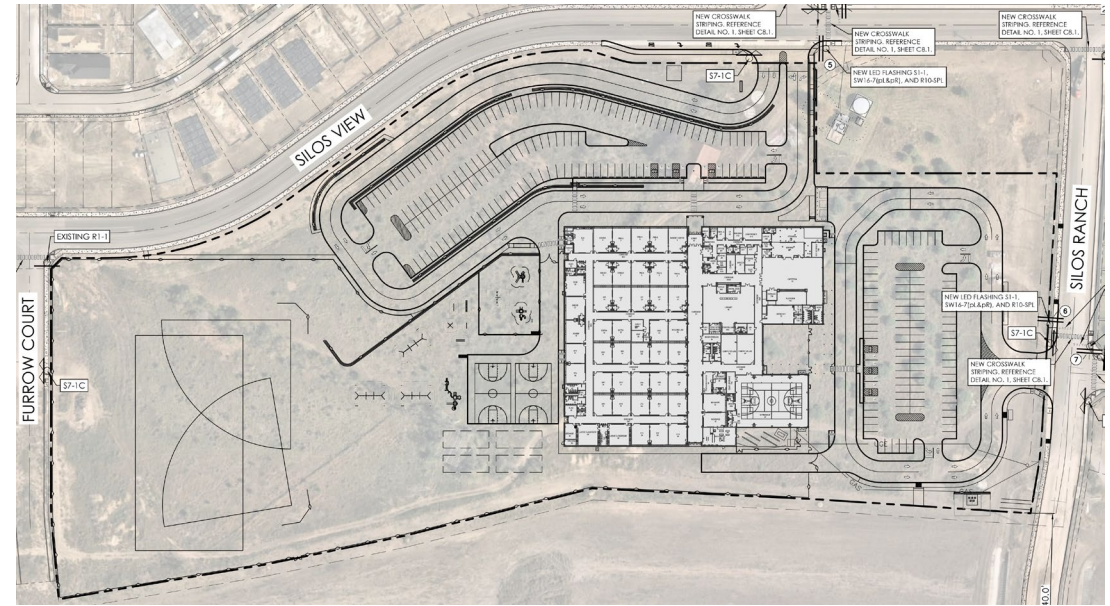

2 WEEK LOOK-AHEAD SUMMARY:

1. Continue pouring concrete on site flatwork
2. Final grade for top-soil and landscaping to begin
3. Start-up on HVAC System
4. Continue finishes throughout
5. Complete installation of millwork
6. Complete installation of hardware
7. Prep site for asphalt

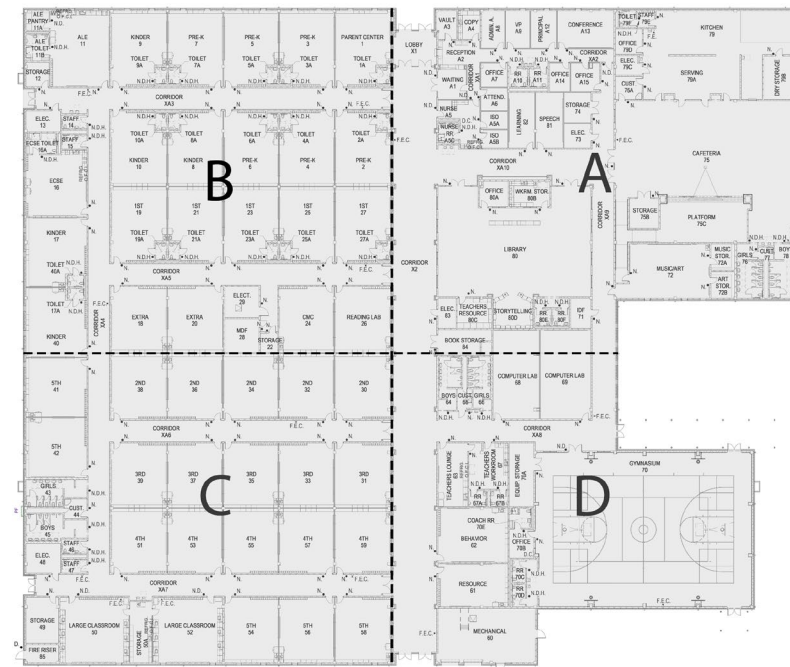





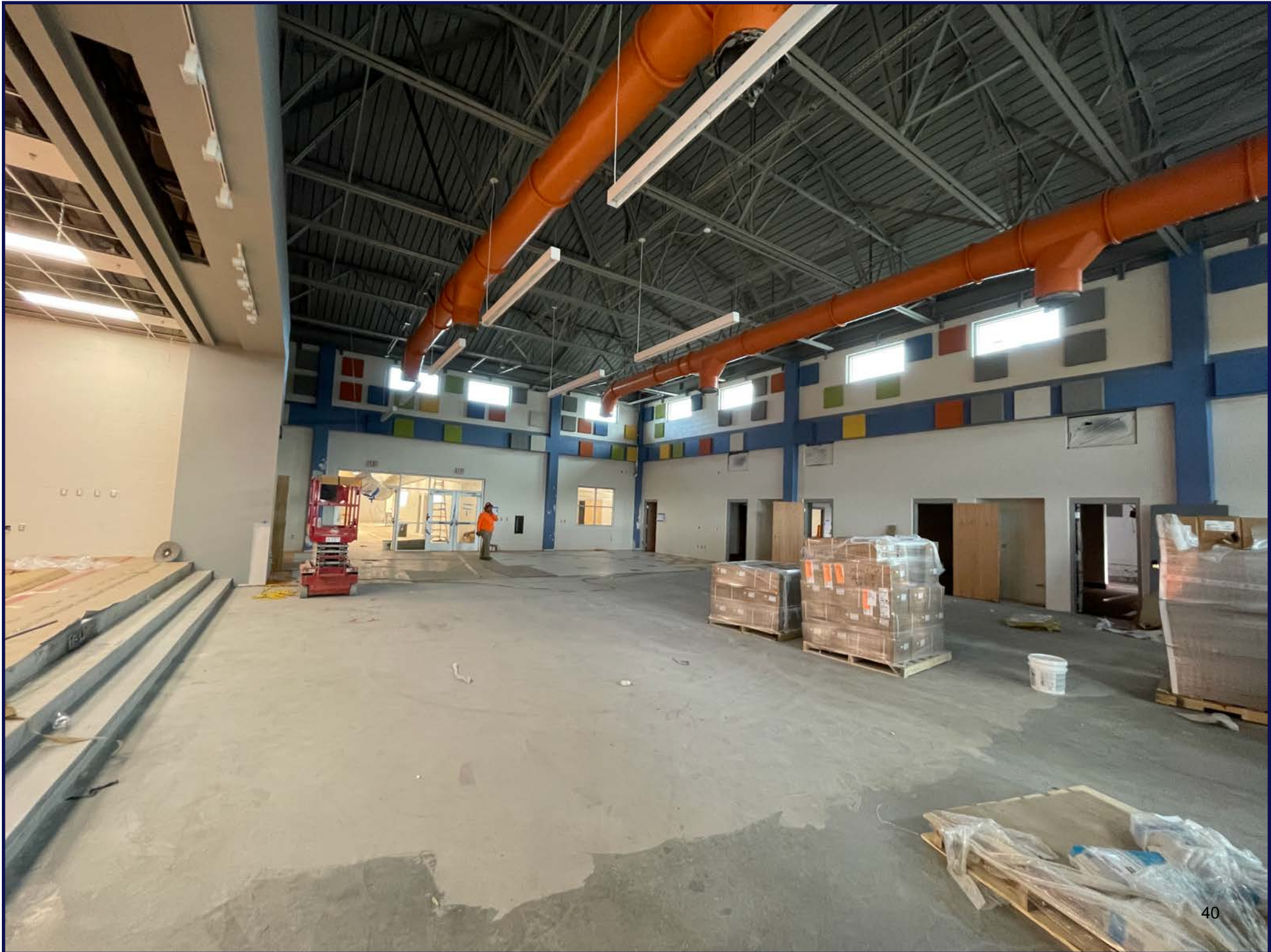

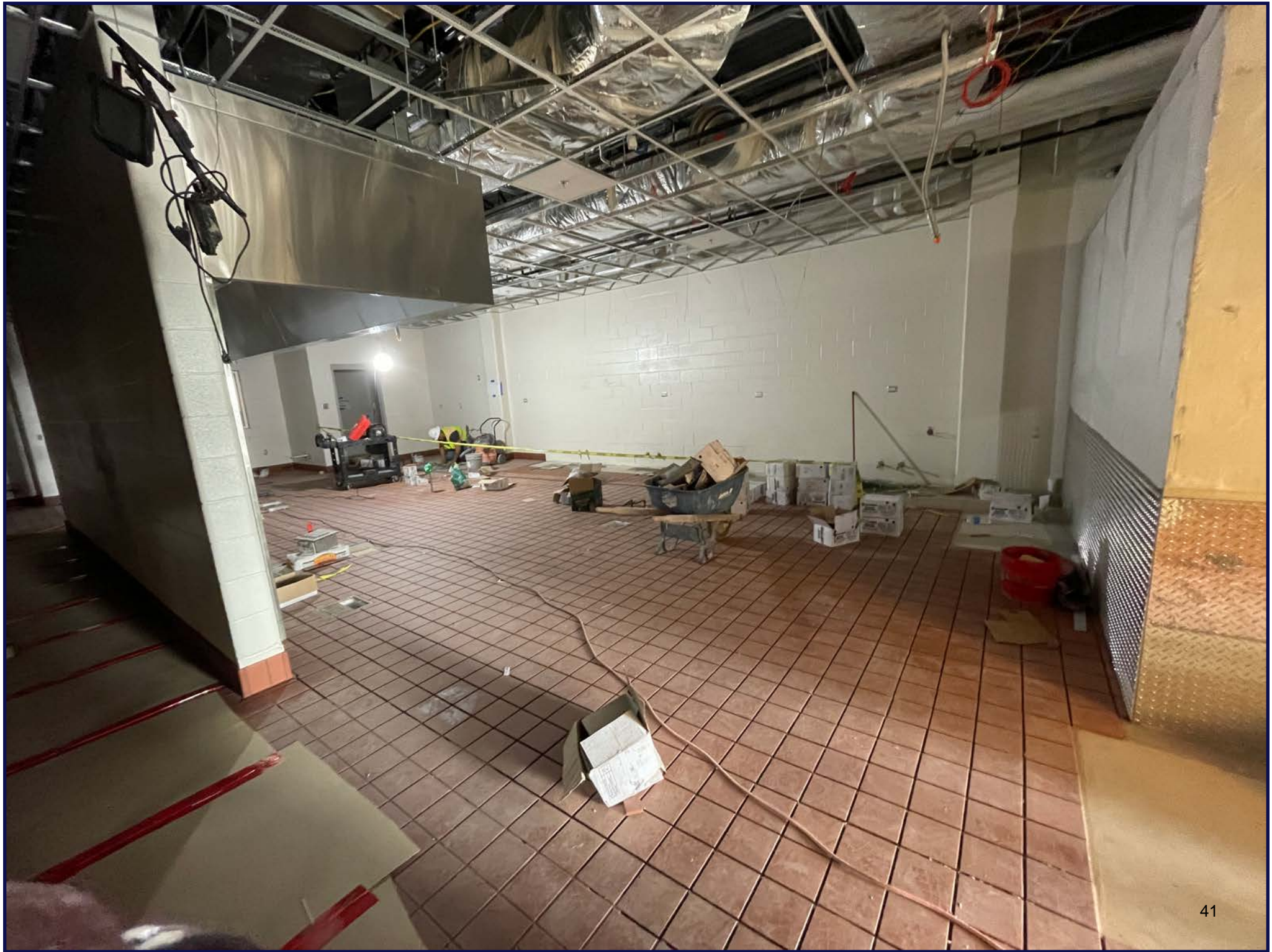







**Board of Trustees Meeting:
Medina Valley High School 2
Construction Briefing**

GENERAL PROJECT SUMMARY:

General Contractor (CMR): Bartlett Cocke General Contractors

Original Substantial Completion Date: June 2026

Requested Days to Date: Zero (0)

Contract Sum (GMP): \$254,950,157.00

Change Order Sum to Date: \$0.00

Current Contract Sum: \$254,950,157.00

Percentage of Work Complete: 5% - Pay Application No. 3 (Jan. 2024)
\$12,593,335 Total Stored/Completed





Medina Valley
INDEPENDENT SCHOOL DISTRICT

**Board of Trustees Meeting:
MVHS Stadium Turf Project
Construction Briefing**

GENERAL PROJECT SUMMARY:

General Contractor (CMR): _____ WR Griggs Construction
Company, Inc

Original Substantial Completion Date: _____ July 2024

Requested Days to Date: _____ Zero (0)

Original Contract Sum (GMP): _____ \$4,947,000.00

Change Order Sum to Date: _____ \$0.00

Current Contract Sum: _____ \$ 4,947,000.00

Percentage of Work Complete: _____ No Pay Applications To-Date



Medina Valley Independent School District

Monthly Financial Report

January 2024

Executive Summary

Financial Highlights: Currently, the district has collected 53% of budgeted revenue and spent 40% of budgeted expenses. The Food Service Fund has collected 50% of budgeted revenues and spent 41% of budgeted expenses. The Debt Service Fund has collected 66% of budgeted revenue and spent 53% of budgeted expenses.

Fund Balance

	General Fund	Food Service	Debt Service
Audited Fund Balance as of August 31, 2023	\$ 29,969,909	\$ 2,953,438	\$ 7,195,244
Year-to-Date Revenue	\$ 45,868,702	\$ 3,007,847	\$ 18,359,310
Year-to-Date Expenditures	\$ (35,376,919)	\$ (2,668,443)	\$ (14,700,105)
Fund Balance as of January 31, 2023	\$ 40,461,692	\$ 3,292,842	\$ 10,854,449

Budget Amendments

	General Fund	Food Service	Debt Service
Revenue	\$ -	\$ -	\$ -
Expenditures	\$ 2,383,395	\$ -	\$ -

**JANUARY 2023-2024
MEDINA VALLEY INDEPENDENT SCHOOL DISTRICT**

ESTIMATED REVENUES	CURRENT BUDGET	YTD ACTUAL	BALANCE
5700 - LOCAL REVENUES	\$35,055,513	\$24,073,292	\$10,982,221
5800 - STATE PROGRAM REVENUES	\$49,155,004	\$21,662,131	\$27,492,873
5900 - FEDERAL REVENUES	\$1,540,000	\$133,279	\$1,406,721
TOTAL REVENUES	\$85,750,517	\$45,868,702	\$39,881,815
PROPOSED APPROPRIATIONS			
11 - INSTRUCTION	\$49,500,770	\$20,193,606	\$29,307,163
12 - INST. RESOURCES & MEDIA SVCS	\$551,395	\$210,365	\$341,030
13 - CURRICULUM DEV.& INST.STF DEV	\$875,433	\$497,839	\$377,594
21 - INSTRUCTIONAL LEADERSHIP	\$1,296,439	\$419,301	\$877,138
23 - SCHOOL LEADERSHIP	\$4,573,079	\$1,827,877	\$2,745,202
31 - GUIDANCE & COUNSELING	\$3,421,399	\$1,312,685	\$2,108,714
32 - SOCIAL WORK SERVICES	\$813,033	\$331,736	\$481,297
33 - HEALTH SERVICES	\$955,682	\$345,092	\$610,590
34 - PUPIL TRANSPORTATION	\$5,430,115	\$2,681,467	\$2,748,647
35 - FOOD SERVICES	\$215,064	\$58,572	\$156,492
36 - COCURR./EXTRACURR.ACTIVITIES	\$2,381,472	\$999,371	\$1,382,101
41 - GENERAL ADMINISTRATION	\$2,722,585	\$1,170,252	\$1,552,333
51 - PLANT MAINTENANCE & OPERATIONS	\$8,816,150	\$3,436,652	\$5,379,498
52 - SECURITY & MONITORING SERVICES	\$1,186,108	\$482,181	\$703,927
53 - DATA PROCESSING SERVICES	\$2,268,611	\$1,163,037	\$1,105,574
61 - COMMUNITY SERVICES	\$9,373	\$4,833	\$4,540
71 - DEBT SERVICES	\$86,065	\$0	\$86,065
81 - FACILITIES ACQ. & CONSTRUCTION	\$1,822,505	\$5,114	\$1,817,392
95 - PYMTS.TO JJAEP PROGRAMS	\$5,000	\$0	\$5,000
99 - OTHER INTERGOVERNMENTAL CHARGE	\$650,000	\$236,940	\$413,060
TOTAL APPROPRIATIONS	\$87,580,277	\$35,376,919	\$52,203,358

2023-2024 FUND BALANCE = \$ 29,969,908

3 MONTH OPERATING CASH FLOW = \$ 21,895,069

**JANUARY 2023-2024
MEDINA VALLEY INDEPENDENT SCHOOL DISTRICT**

ESTIMATED REVENUES	CURRENT BUDGET	YTD ACTUAL	BALANCE
5700 - LOCAL REVENUES	\$1,875,327	\$872,705	\$1,002,622
5800 - STATE PROGRAM REVENUES	\$35,438	\$0	\$35,438
5900 - FEDERAL REVENUES	\$4,029,726	\$2,135,142	\$1,894,584
TOTAL REVENUES	\$5,940,491	\$3,007,847	\$2,932,644
PROPOSED APPROPRIATIONS			
35 - FOOD SERVICES	\$6,512,006	\$2,668,443	\$3,843,563
TOTAL APPROPRIATIONS	\$6,512,006	\$2,668,443	\$3,843,563

2023-2024 FUND BALANCE = \$ 2,953,438

3 MONTH OPERATING CASH FLOW = \$ 1,628,002

**JANUARY 2023-2024
MEDINA VALLEY INDEPENDENT SCHOOL DISTRICT**

ESTIMATED REVENUES	CURRENT BUDGET	YTD ACTUAL	BALANCE
5700 - LOCAL REVENUES	\$24,540,481	\$17,391,809	\$7,148,672
5800 - STATE PROGRAM REVENUES	\$3,343,378	\$967,501	\$2,375,877
TOTAL REVENUES	\$27,883,859	\$18,359,310	\$9,524,549
PROPOSED APPROPRIATIONS			
71 - DEBT SERVICES	\$27,883,859	\$14,700,105	\$13,183,755
TOTAL APPROPRIATIONS	\$27,883,859	\$14,700,105	\$13,183,755

2023-2024 FUND BALANCE = \$ 7,195,244

3 MONTH OPERATING CASH FLOW = \$ 6,970,965

Medina Valley ISD

Bond 2023 Summary

As of January 31, 2024

<i>2023 Bond Projects</i>	<i>Original Budget</i>	<i>Adjusted Budget</i>	<i>Cumulative Encumbrances</i>	<i>Cumulative Expenses</i>	<i>Balance</i>
High School #2	\$ 323,000,000	\$ 323,000,000	\$ 255,138,559	\$ 14,066,346	\$ 53,795,095
Traffic Improvements	\$ 4,000,000	\$ 4,000,000	\$ 268,479	\$ 1,069,728	\$ 2,661,793
Agricultural & Jr. ROTC Facility	\$ 14,000,000	\$ 14,000,000	\$ -	\$ -	\$ 14,000,000
Safety & Security Projects	\$ 5,000,000	\$ 5,000,000	\$ -	\$ 46,431	\$ 4,953,569
Land	\$ 30,000,000	\$ 30,000,000	\$ 219,921	\$ 3,791,296	\$ 25,988,783
Project Savings	\$ -	\$ -	\$ -	\$ -	\$ -
Total Projects	\$ 376,000,000	\$ 376,000,000	\$ 255,626,960	\$ 18,973,801	\$ 101,399,240
Fees Associated with Sale of Bond		\$ 830,037	\$ -	\$ 830,037	\$ -
Total Bond Package	\$ 376,000,000	\$ 376,830,037	\$ 255,626,960	\$ 19,803,838	\$ 101,399,240
Bond Interest		\$ 9,921,894	\$ -	\$ -	\$ 9,921,894
Salaries	\$ -	\$ 102,355	\$ -	\$ 102,355	\$ -
Total Interest Earnings	\$ -	\$ 10,024,249	\$ -	\$ 102,355	\$ 9,921,894

**Unaudited*

SCORECARD PRIORITY #1
EVERY STUDENT GROWS EVERY YEAR

LET'S

GROW

TOGETHER



DISTRICT SCORECARD

PRIORITIES

1. Every student grows every year
2. Recruit and retain staff
3. Foster an environment of parental and community involvement
4. Finance & Operations

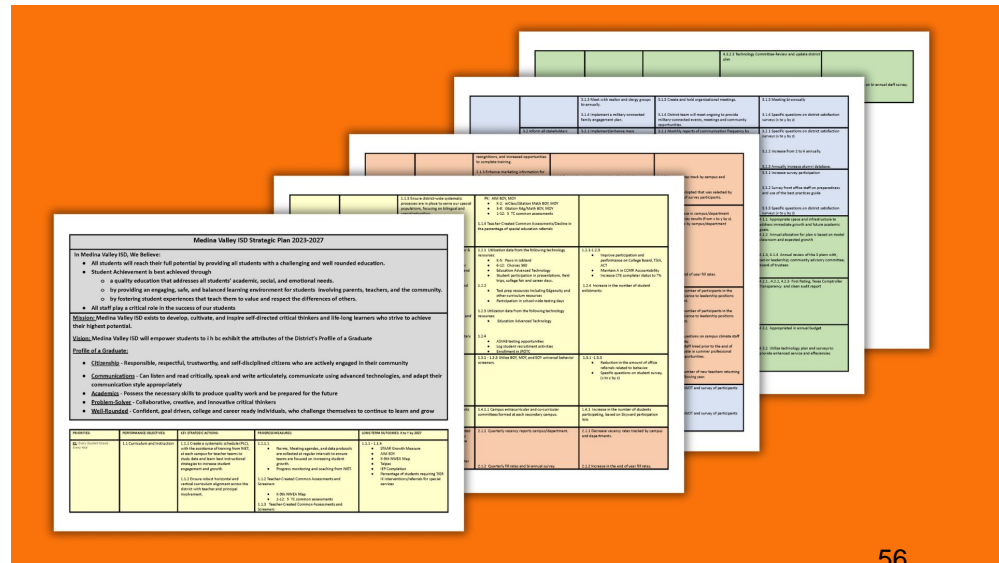

DISTRICT SCORECARD

Curriculum and Instruction

1.1.1 Create a systematic schedule (PLC), with the assistance of training from NIET, at each campus for teacher teams to study data and learn best instructional strategies to increase student engagement and growth

1.1.2 Ensure Robust horizontal and vertical curriculum alignment across the district with teacher and principal involvement

1.1.3 Ensure district-wide systematic processes are in place to serve our special populations, focusing on bilingual and special education.

1.1.4 Strengthen MTSS process with district-wide procedures and interventions.

DISTRICT SCORECARD 1.1.1

Mathematics

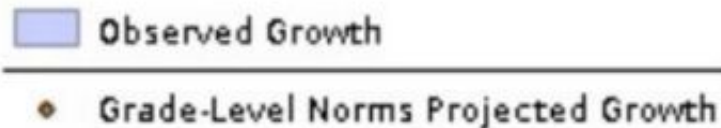
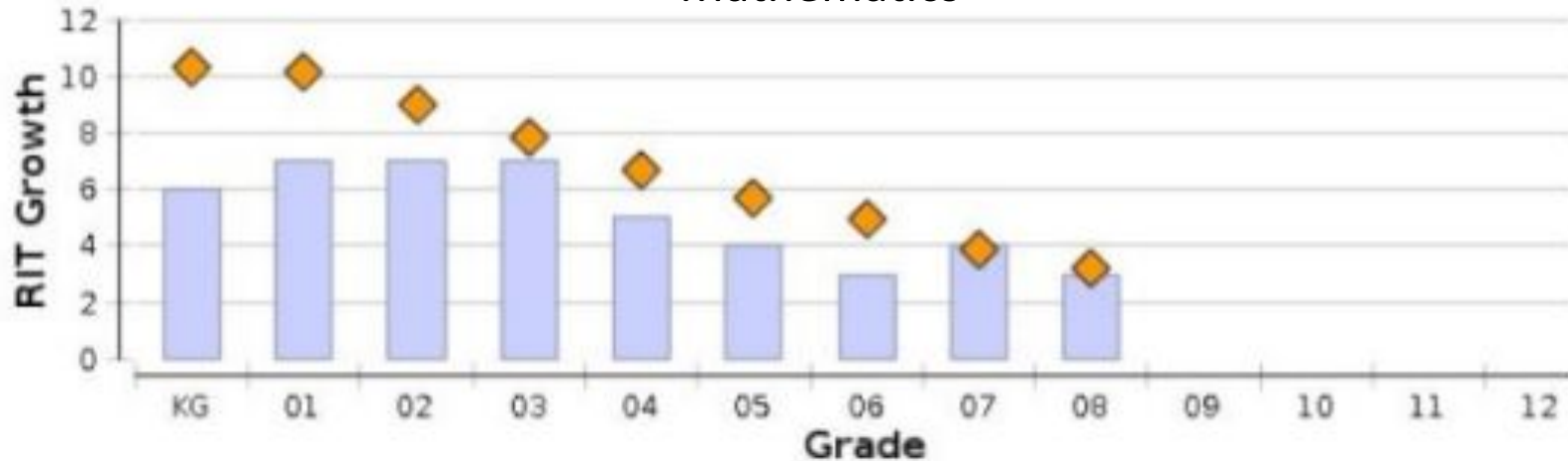

DISTRICT SCORECARD 1.1.1

MVISD Math K-12 Student Map Growth: Fall to Winter

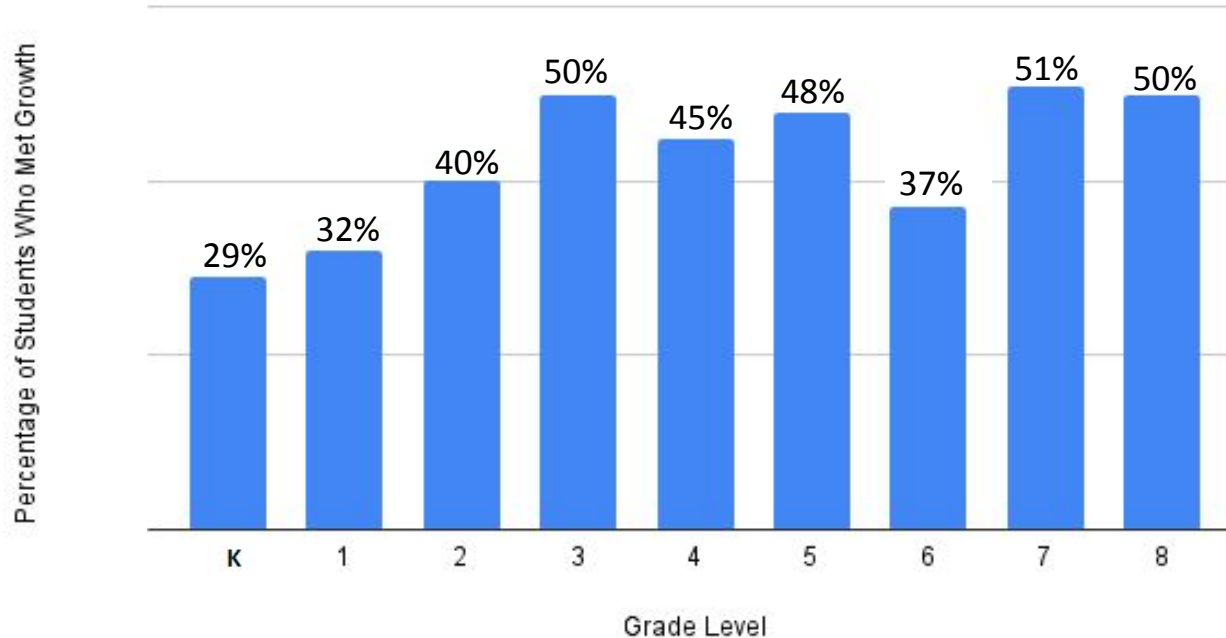

DISTRICT SCORECARD 1.1.1

MVISD Algebra 1 Student Map Growth: Fall to Winter

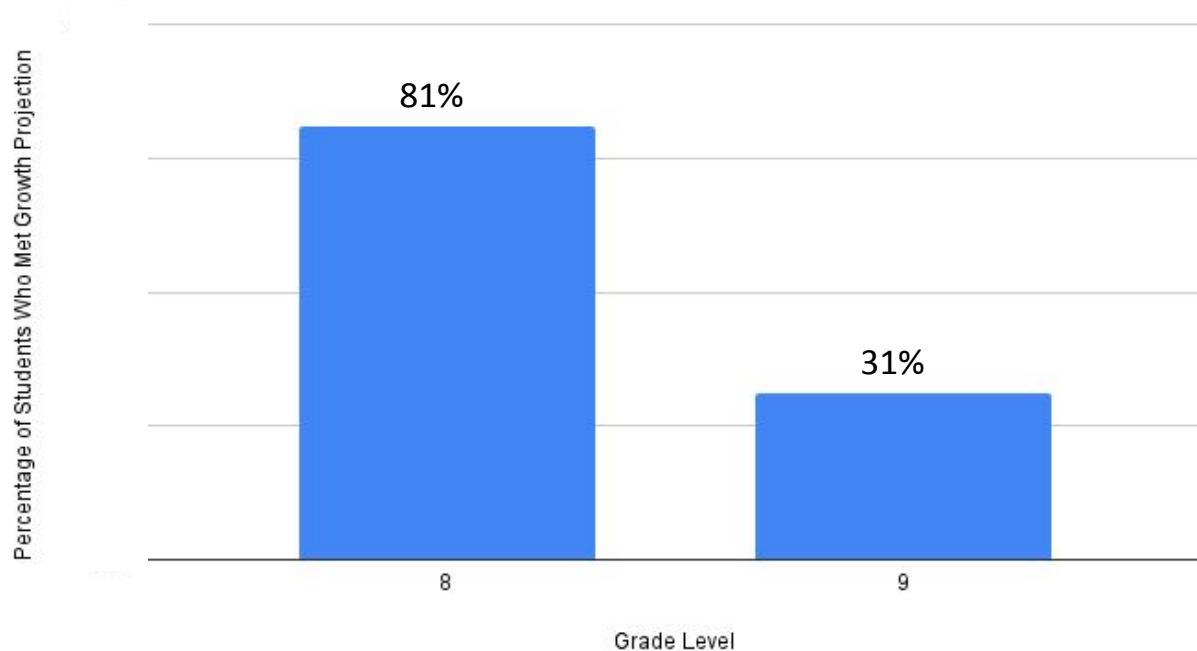

DISTRICT SCORECARD 1.1.1



Grades 2 - 8
State of Texas Assessments
of Academic Readiness
Math taken in the Spring of
2024.

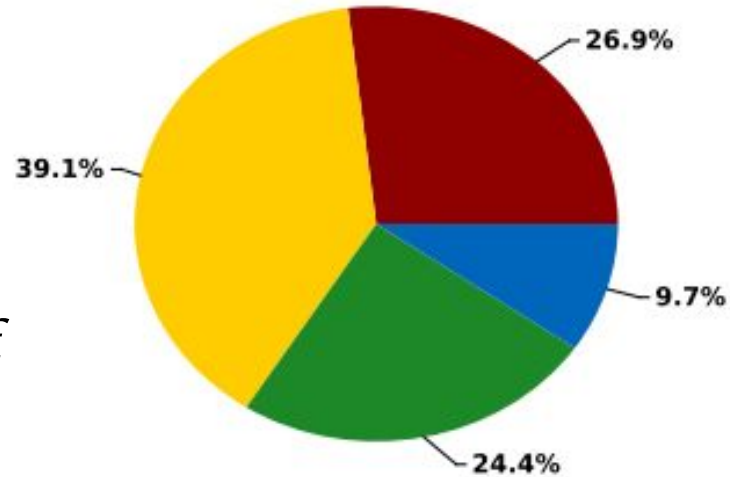

DISTRICT SCORECARD 1.1.1



State of Texas Assessments of Academic Readiness
End-of-Course **Algebra 1** taken
in the Spring of 2024.

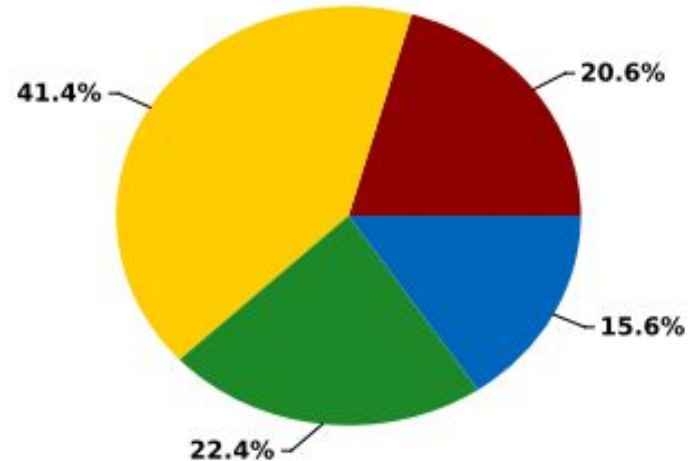

DISTRICT SCORECARD 1.1.1

English/ Language Arts

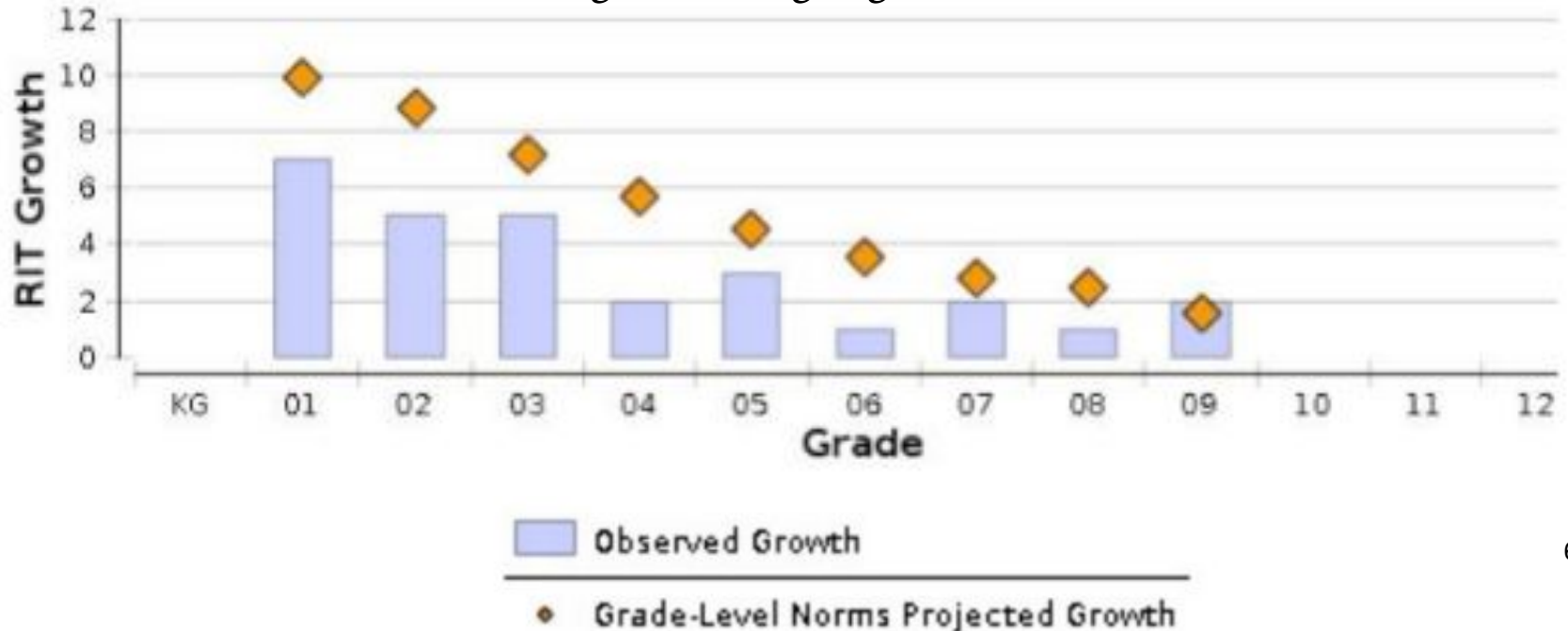

DISTRICT SCORECARD 1.1.1

MVISD ELAR 1 - 9 Student Map Growth: Fall to Winter

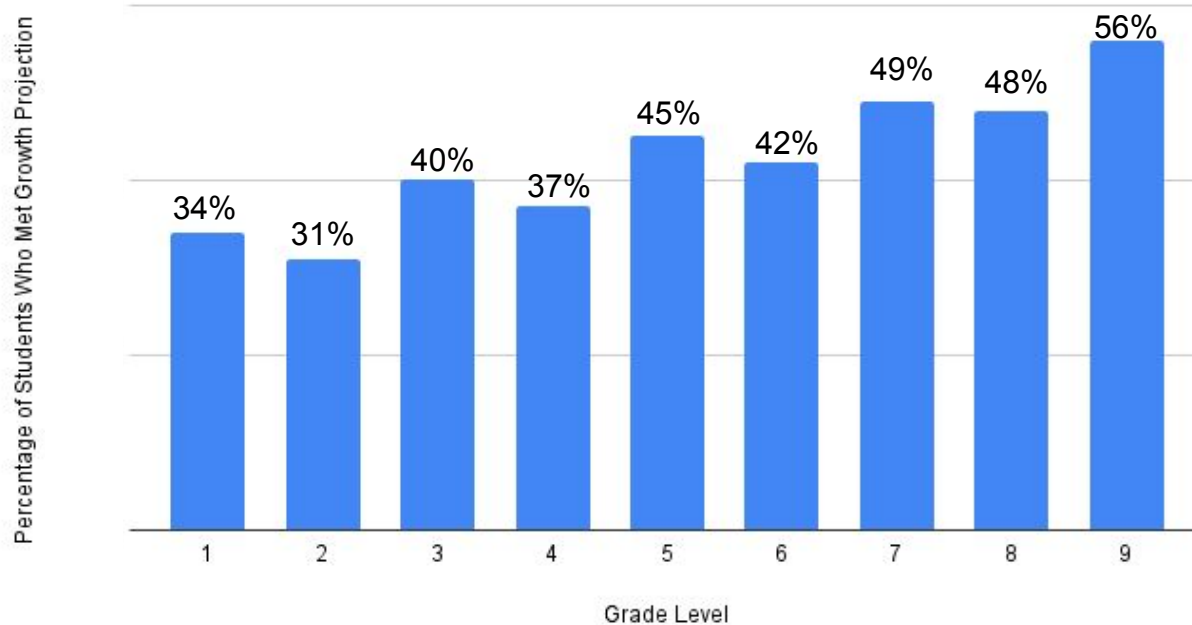

DISTRICT SCORECARD 1.1.1

MVISD ELAR Spanish K-12 Student Map Growth: Fall to Winter

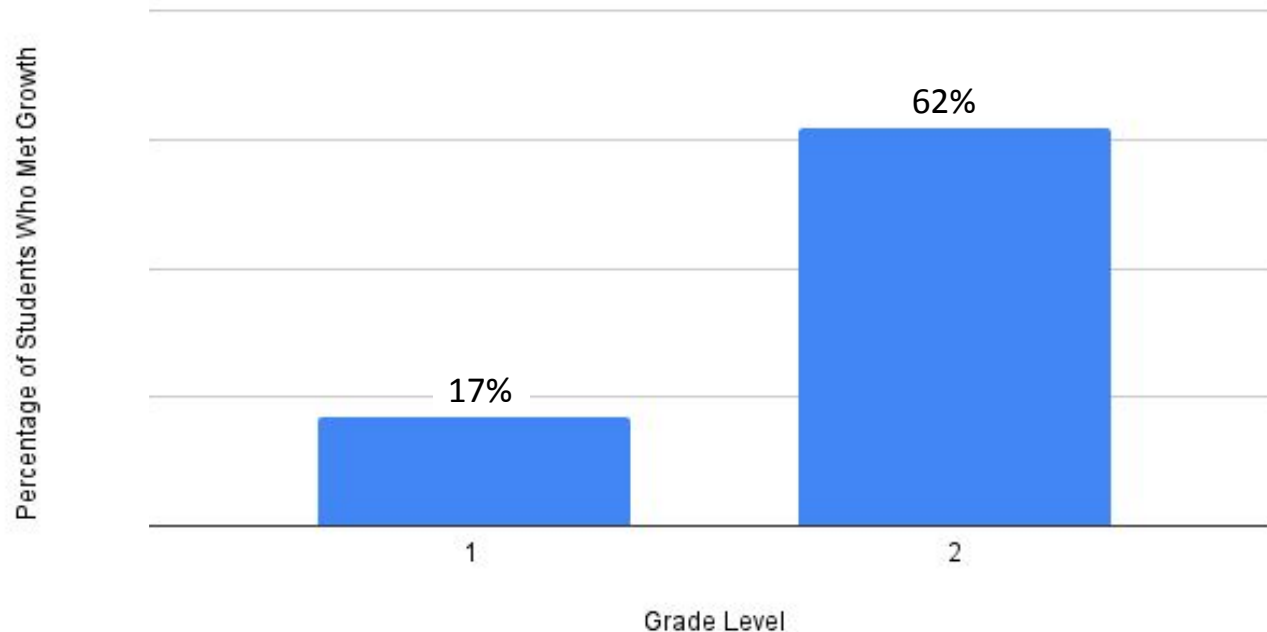

DISTRICT SCORECARD 1.1.1



Grades 2 - 8
State of Texas Assessments
of Academic Readiness
Reading taken in the Spring
of 2024.

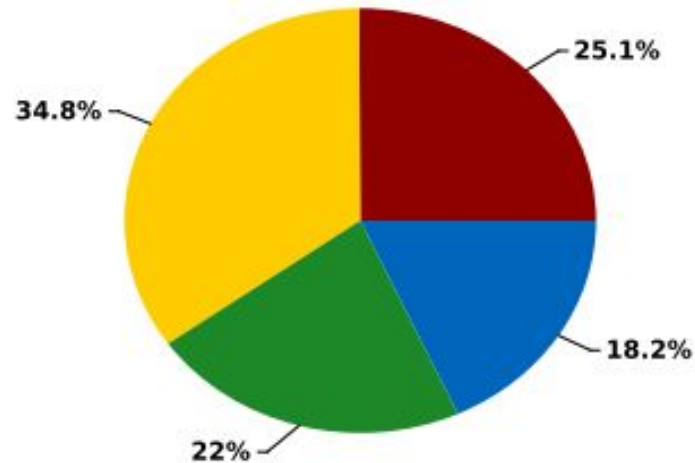

DISTRICT SCORECARD 1.1.1



State of Texas Assessments of
Academic Readiness
End-of-Course **English 1**
taken in the Spring of 2024.

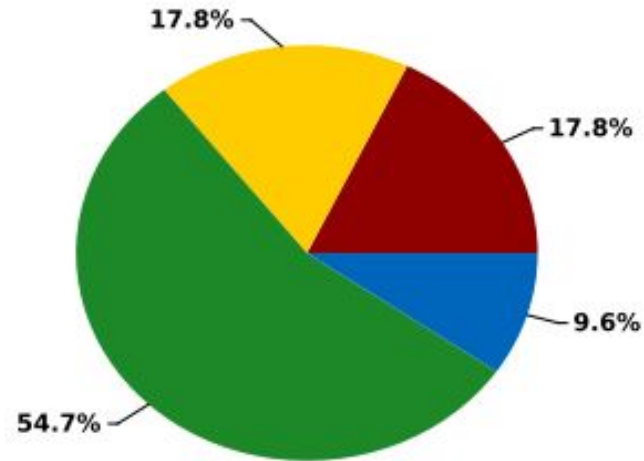

DISTRICT SCORECARD

College, Career & Military Readiness

1.2.1 Implement a K-12 College, Career & Military Readiness Program including age appropriate counseling lessons, technology resources, college & career presentations/field trips, college fair, and advanced academics.

1.2.2 Increase testing opportunities and offer curriculum support, including technology, in AP, TSIA, PSAT/SAT/ACT.

1.2.3 Increase alignment for CTE Completer Status, District Practicums, and IBC attainment

1.2.4 Support Students to explore military enlistment opportunities
Professional Development and Leadership Opportunities

DISTRICT SCORECARD 1.2.1 - 1.2.4

1.2.1 The CTE Department held presentations for 8th grade students at both Middle Schools on MVHS Programs of Study so they could make informed decisions when choosing their endorsement paths for high school. In addition, 8th grade students attended a Core4 Stem field trip to Boeing Center at Tech Port.

1.2.2 Free, Schoolwide Testing days (October 17, March 26, and April 2) are available to students to take TSIA, PSAT, SAT, and ACT.

Baseline data from TAPR (graduating class of 2022):

- 16.1% of students met the criterion for TSIA in Reading
- 21.8% of students met the criterion for TSIA in Math
- 43.4% of students took the ACT or SAT.

DISTRICT SCORECARD 1.2.1 - 1.2.4

1.2.3 Baseline data from TAPR (graduating class of 2022): 29.3% of graduates were CTE Completers.

- Course Selection Committee meetings on 11/28 and 12/4 to align and approve additional courses for level 3 and level 4 classes/practicums in Programs of Study.
- CTE Advisory Group met to discuss community partnerships for student internship options.
- This summer, CTE teachers will align Programs of Study with new Industry Based Certifications.

1.2.4 Students have the opportunity to take the ASVAB Test at the high school and recruiters from all branches of the military are available to meet with students during lunches.

DISTRICT SCORECARD

Safety and Well-being

- 1.3.1 Implement Emergent Tree to provide clear, consistent positive behavior support system
- 1.3.2 Implement Character Strong to provide a clear, consistent character education program
- 1.3.3 Provide consistent systematic social-emotional learning.

DISTRICT SCORECARD 1.3.1 1.3.2 1.3.3

- All campuses created an Emergent Tree Grounds Work team that received two days of training on August 4, 2023, and November 6, 2023. The teams then delivered the training to their individual campuses.
- All campuses received coaching on Tier I implementation on 9/25/23-9/27/23 and 1/22/24-1/24/24 and received verbal and written feedback on next steps of implementation.
- All campuses administered BOY Universal Screener Oct.16-23, 2023 to use the data in their Multi Tiered System Support (MTSS) teams to address individual students needs.
- All Elementary School Counselors have implemented Character Strong into their guidance lessons. Middle School campuses have integrated Character Strong lessons into their collaborative grade level rotations with teachers.

DISTRICT SCORECARD 1.3.1 1.3.2 1.3.3

Discipline Data

District Alternative Educational Placements (DAEP) August 21, 2023-Present	
Secondary	110
Elementary	3

In-School and Out-of-School Discipline Removals August 21, 2023-Present	
Secondary	1,329
Elementary	135

DISTRICT SCORECARD 1.3.1 1.3.2 1.3.3

Fall Student Survey Data

Secondary

I feel safe at school.

Strongly Disagree	Disagree	No Opinion	Agree	Strongly Agree	Answers Received
8.40%	12.95%	34.94%	32.71%	11.00%	2,773

Elementary

Do you feel safe at school?

No	Sometimes	Yes	Answers Received
8.23%	30.24%	61.53%	1,227

DISTRICT SCORECARD 1.3.1 1.3.2 1.3.3

Daily Average Attendance Data

Average Daily Attendance 2023-2024 Medina Valley ISD		
1st 6 weeks	2nd 6weeks	3rd 6 weeks
95%	93.4%	93.3%

DISTRICT SCORECARD

Extracurricular and Co-Curricular Participation (Grades 6-12)

1.4.1 Increase opportunities for students in extracurricular and co-curricular participation.

Baseline Data:

- MVHS - 53% Participation rate
- MVMS - 78% Participation rate
- Loma - 82% Participation rate

Medina Valley Independent School District

Agenda Item Memorandum

To: MVISD Board of Trustees

Date: February 12, 2024

RE: First Reading for District Initiated Revisions to Local Policies FFA, FMH, and EI

FFA (LOCAL)

There is currently one district position responsible to oversee the implementation of the policy and the development and implementation of the wellness plan and appropriate administrative procedures. This revision recommends the addition of two additional district positions.

FMH (LOCAL)

This revision recommends that a student who has satisfactorily completed all coursework requirements for graduation but has failed to meet applicable state testing requirements shall be allowed to participate in commencement activities and ceremonies.

EI (LOCAL)

This revision recommends that the District issue certificates of coursework completion to students who have successfully completed state and local credit requirements for graduation but has failed to meet all state and local requirements for graduation.

PROPOSED REVISIONS

The District shall support the general wellness of all students by implementing measurable goals to promote sound nutrition and student health and to reduce childhood obesity.

[See EHAA for information regarding the District's coordinated school health program.]

Development, Implementation, and Review of Guidelines and Goals

The local school health advisory council (SHAC), on behalf of the District, shall review and consider evidence-based strategies and techniques and shall develop nutrition guidelines and wellness goals as required by law. In the development, implementation, and review of these guidelines and goals, the SHAC shall permit participation by parents, students, representatives of the District's food service provider, physical education teachers, school health professionals, members of the Board, school administrators, and members of the public.

[See BDF for required membership of the SHAC.]

Wellness Plan

The SHAC shall develop a wellness plan to implement the District's nutrition guidelines and wellness goals. The wellness plan shall, at a minimum, address:

1. Strategies for soliciting involvement by and input from persons interested in the wellness plan and policy;
2. Objectives, benchmarks, and activities for implementing the wellness goals;
3. Methods for measuring implementation of the wellness goals;
4. The District's standards for foods and beverages provided, but not sold, to students during the school day on a school campus; and
5. The manner of communicating to the public applicable information about the District's wellness policy and plan.

The SHAC shall review and revise the plan on a regular basis and recommend revisions to the wellness policy when necessary.

Nutrition Guidelines

Foods and Beverages Sold

The District's nutrition guidelines for reimbursable school meals and all other foods and beverages sold or marketed to students during the school day shall be designed to promote student health and reduce childhood obesity and shall be at least as restrictive as federal regulations and guidance, except when the District allows an exemption for fundraising activities as authorized by state and federal rules. [See CO and FJ]

Foods and
Beverages Provided

The District shall establish standards for all foods and beverages provided, but not sold, to students during the school day. These standards shall be addressed in the District's wellness plan.

Wellness Goals

Nutrition Promotion
and Education

The District shall implement, in accordance with law, a coordinated school health program with a nutrition education component. [See EHAA] The District's nutrition promotion activities shall encourage participation in the National School Lunch Program, the School Breakfast Program, and any other supplemental food and nutrition programs offered by the District.

The District establishes the following goals for nutrition promotion:

1. The District's food service staff, teachers, and other District personnel shall consistently promote healthy nutrition messages in cafeterias, classrooms, and other appropriate settings.
2. The District shall share educational nutrition information with families and the general public to promote healthy nutrition choices and positively influence the health of students.

The District establishes the following goal for nutrition education: The District shall deliver nutrition education that fosters the adoption and maintenance of healthy eating behaviors.

Physical Activity

The District shall implement, in accordance with law, a coordinated health program with physical education and physical activity components and shall offer at least the required amount of physical activity for all grades. [See BDF, EHAA, EHAB, and EHAC]

The District establishes the following goals for physical activity:

1. The District shall provide an environment that fosters safe, enjoyable, and developmentally appropriate fitness activities for all students, including those who are not participating in physical education classes or competitive sports.
2. The District shall make appropriate training and other activities available to District employees in order to promote enjoyable, lifelong physical activity for District employees and students.
3. The District shall encourage parents to support their children's participation, to be active role models, and to include physical activity in family events.
4. The District shall encourage students, parents, staff, and community members to use the District's recreational facilities, such as tracks, playgrounds, and the like, that are available outside of the school day. [See GKD]

STUDENT WELFARE
WELLNESS AND HEALTH SERVICES

FFA
(LOCAL)

Other School-Based
Activities

The District establishes the following goals to create an environment conducive to healthful eating and physical activity and to promote and express a consistent wellness message through other school-based activities:

1. The District shall allow sufficient time for students to eat meals in cafeteria facilities that are clean, safe, and comfortable.
2. The District shall promote wellness for students and their families at suitable District and campus activities.
3. The District shall promote employee wellness activities and involvement at suitable District and campus activities.

Implementation

The director of curriculum, instruction, and assessment, [the director of child nutrition, and the director of health and safety](#) shall oversee the implementation of this policy and the development and implementation of the wellness plan and appropriate administrative procedures.

Evaluation

The District shall comply with federal requirements for evaluating this policy and the wellness plan.

Public Notification

The District shall annually inform and update the public about the content and implementation of the wellness policy, including posting on its website copies of the wellness policy, the wellness plan, and the required implementation assessment.

Records Retention

The District shall retain all the required records associated with the wellness policy, in accordance with law and the District's records management program. [See CPC and FFA(LEGAL)]

PROPOSED REVISIONS

**Commencement
Exercises**

A student who has satisfactorily completed all coursework requirements for graduation but has failed to meet applicable state testing requirements shall be allowed to participate in commencement activities and ceremonies. ~~To be eligible to participate in commencement activities and ceremonies, a student shall meet all state and local graduation requirements, including all applicable state testing.~~ [See EI, EIF]

PROPOSED REVISIONS

**Certificate of
Coursework
Completion**

The District shall ~~not~~ issue a certificate of coursework completion to a student who has successfully completed state and local credit requirements for graduation but has failed fails to meet all state and local requirements for graduation. [See EIF, FMH]

Partial Credit

When a student earns a passing grade in only half of a course and the combined grade for both halves is lower than 70, the District shall award the student credit for the half with the passing grade.



Medina Valley
INDEPENDENT SCHOOL DISTRICT

Superintendent Briefing

February 26, 2024



The students from Castroville Elementary won the District UIL Elementary title.



The finalists from all the elementary schools showcased their skills in categories such as art, chess puzzle, dictionary, listening, maps, music memory, number sense, and spelling.



MVHS senior volleyball player Lexi Tedford received the Texas Student-Athlete of the Year award along with a \$1,000 Letterman 2 Leadership Scholarship.



MVHS senior Matthew Tschirhart was selected out of 15,000 students nationwide as a 2025 National Merit Scholarship Competition finalist. Good luck Matthew!



MVHS Athletes signed their letters of intent to attend:

Kaylee Upton - Western Texas College

Tanith Chappie - Texas Woman's University

Ty Millis - McPherson College

Paetyn Ellis - Howard Payne University





MVHS senior Garrett Echtle won Reserve Champion Dark OPB and secured a sale spot at the Fort Worth Livestock Show.



Medina Valley HS SkillsUSA construction and automotive students are state-bound after an impressive performance at the District 11 SkillsUSA competition.



Over 500 MVHS students volunteered for more than 15 community service projects on the fourth annual Make a Difference Day.



The Medina Valley MS students, staff and community joined forces to collect teddy bear donations for the the Bereavement Center of San Antonio.



Castroville Chamber of Commerce Banquet



MVHS Seniors Natalie Brooks and Brady Prukop received Jr. Citizens of the Year award.



Mrs. Nadine Kempf from LaCoste Elementary was recognized as Educator of the Year.

Employees of the Month



LaCoste Elementary,
Pre-K Instructional Assistant
Lorie Pimentel

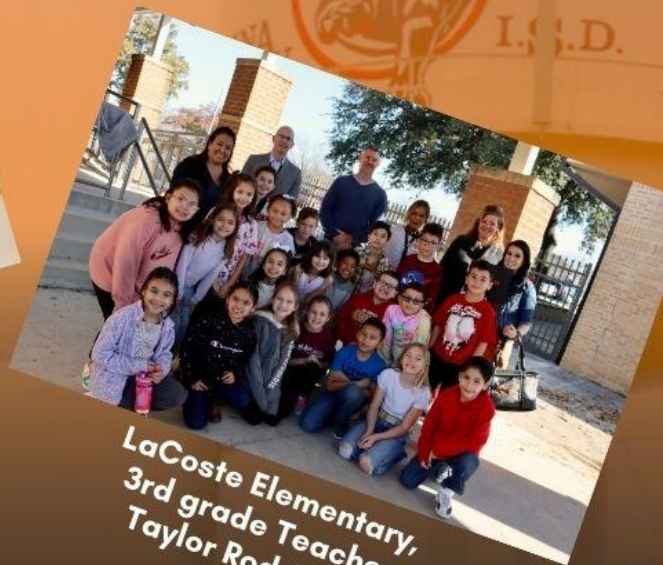

LaCoste Elementary,
3rd grade Teacher
Taylor Rodriguez

✦ February 2024 ✦



MVISD Athletic Director Douglas Bull is being inducted to the NHSSCA Hall of Fame. This award honors coaches who have made a substantial impact in the field of high school strength and conditioning over the course of their professional career.

Congratulations, Coach Bull!

The MVISD Transportation Department cooked up a delicious pancake breakfast to show appreciation for our amazing bus drivers and transportation staff during National School Bus Driver Appreciation Day.





SCHOOL COUNSELING

NATIONAL
SCHOOL
COUNSELING
WEEK

FEBRUARY 5-9, 2024

STUDENT-FOCUSED

STANDARDS-BASED,

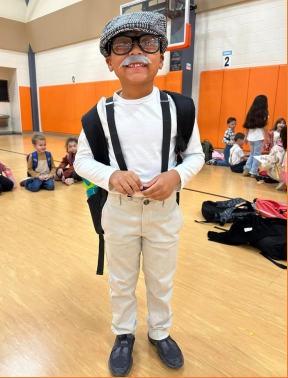

100 Days of School

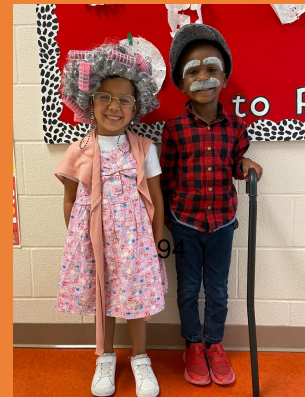
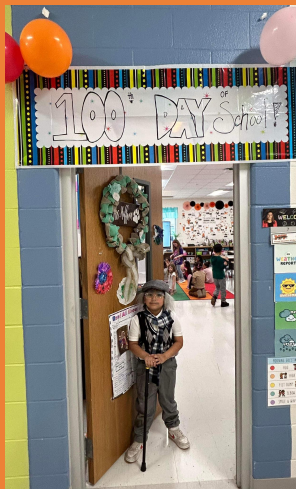
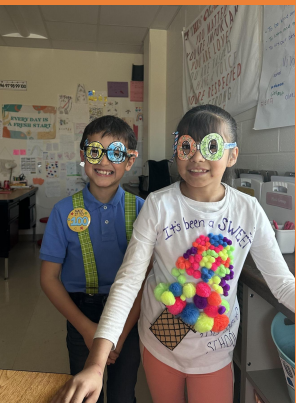

DISTRICT ENROLLMENT

	5/25/23	2/21/24
Castroville Elementary	646	627
LaCoste Elementary	771	921
Ladera Elementary	778	916
Luckey Ranch Elementary	892	984
Potranco Elementary	899	917
Medina Valley Middle School	1,051	1,081
Loma Alta Middle School	801	926
Medina Valley High School	2,113	2,355
DISTRICT-WIDE	7,951	8,727

Medina Valley Independent School District
Regular School Board Meeting

Board Minutes

January 22, 2024, 6:00 PM

MVISD Board Room, 8449 FM 471 S., Castroville, TX 78009

A **Regular Board Meeting** of the Board of Trustees was held Monday, January 22, 2024, beginning at 6:00 pm at the Medina Valley ISD Central Office Board Room.

I. First Order of Business

A Call Meeting to Order

Beth Zinsmeyer, Board President, called the Medina Valley ISD Regular Board Meeting to order at 6:00 pm.

B Establish a Quorum

A quorum of the Board Members were present, Matt Castiglione, Jennilea Campbell, Veronica Cavazos, Jason Bonney, Nathan Fillingier, Blane Nash and Beth Zinsmeyer.

C Pledge of Allegiance to the Flag followed by a moment of silence

Everyone joined in the Pledge of Allegiance to the American Flag and the Texas Flag, followed by a moment of silence.

II. School Board Appreciation - presentation included a video and presentation by MVHS.

III. Medina Valley Education Foundation Logo Winner – The Medina Valley Education Foundation presented a plaque to their Logo Contest winner.

IV. Public Comment - none

V. Announcements/Communications/Presentations

A A Bond Committee Presentation was shared with the Board.

B Board Committee Reports

- Finance & Operations Committee, presented by Matt Castiglione, Committee Chair
- Construction Committee, presented by Blane Nash, Committee Chair
- Curriculum Committee, presented by Veronica Cavazos, Committee Chair

C Construction Briefing, presented by Rafael Barajas

- Silos Elementary
- High School #2

D Financial Briefing, presented by Crystal Hermes

- General Fund Financial Statement
- Child Nutrition Financial Statement
- Debt Service Fund Financial Statement

Medina Valley Independent School District
Regular School Board Meeting

Board Minutes

January 22, 2024, 6:00 PM

MVISD Board Room, 8449 FM 471 S., Castroville, TX 78009

- Bond 2023 Capital Projects Report

- E Superintendent Briefing, presented by Dr. Caloss
- Student Achievements
 - Staff Achievements
 - District Enrollment Numbers

VI. Discussion and Possible Action Items

- A Consider Approval of Minutes for Regular Board Meeting on December 18, 2023 and Special Board Meeting on December 18, 2023

Jason Bonney made a Motion, seconded by Matt Castiglione, to approve the Board Minutes for the December 18, 2023 Regular Meeting and December 18, 2023 Special Meeting as presented. All of the Board Members voted for and the Motion passed.

- B Consider Approval of Amendment to the Guaranteed Maximum Price (GMP) for Medina Valley ISD's High School #2

Blane Nash made a Motion, seconded by Nathan Fillinger, to approve the Amendment to the Guaranteed Maximum Price (GMP) for Medina Valley ISD's High School #2 as presented. All of the Board Members voted for and the Motion passed.

- C Consider Approval of Final Completion for the Medina Valley Middle School Traffic Improvement Project

Matt Castiglione made a Motion, seconded by Jason Bonney, to approve the Final Completion for the Medina Valley Middle School Traffic Improvement Project as presented. All of the Board Members voted for and the Motion passed.

- D Consider Approval of CPS Right-Of-Way Agreement for Silos Elementary School

Matt Castiglione made a Motion, seconded by Veronica Cavazos, to approve the CPS Right-Of-Way Agreement for Silos Elementary School as presented. All of the Board Members voted for and the Motion passed.

- E Consider Approval of the 2024-2025 Academic Calendar and 2024-2025 Flex Calendar

Nathan Fillinger made a Motion, seconded by Jason Bonney, to approve the 2024-2025 Academic Calendar and the 2024-2025 Flex Calendar as presented. All of the Board Members voted for and the Motion passed.

- F Consider Approval of Medina Valley ISD's Branding Guide for High Schools

Medina Valley Independent School District
Regular School Board Meeting

Board Minutes

January 22, 2024, 6:00 PM

MVISD Board Room, 8449 FM 471 S., Castroville, TX 78009

Jennilea Campbell made a Motion, seconded by Veronica Cavazos, to approve the Medina Valley ISD’s Branding Guide for High Schools as presented. All of the Board Members voted for and the Motion passed.

- G Consider Approval of the TASB initiated Local Policy Update 122, affecting Local Policies CQB, CSA, DC, EHB, EHBC, EHBCA, FEA, FFAC, FFB, and FL

Matt Castiglione made a Motion, seconded by Jason Bonney, to approve the TASB initiated Local Policy Update 122, affecting Local Policies CQB, CSA, DC, EHB, EHBC, EHBCA, FEA, FFAC, FFB, and FL as presented. All of the Board Members voted for and the Motion passed.

VII. Closed Session

Board President, Beth Zinsmeyer announced at 7:15pm that the Board of Trustees would convene in closed session as authorized by Section 551.074, and 551.076 of the Texas Open Meetings Act to consider agenda item VI A and B. No Action would be taken in closed session.

- A Personnel Matters: Resignations, Retirements, Leaves of Absence, Reassignments, New Employment, New Personnel Position, Duties/Responsibilities of Employees (TX Govt. Code Section 551.074)
- B Considering the deployment, specific occasions for, or implementation of, security personnel or devices (TX Govt. Code Section 551.076)

Board President Beth Zinsmeyer announced that the Board would reconvene into Open Session on January 22, 2024 at 7:52 pm.

VIII. Continued Discussion and Possible Action Items

- A Consideration of future meeting dates

The next Regular Board Meeting is scheduled for February 26, 2024.

IX. Adjournment

Jason Bonney made a Motion, seconded by Nathan Fillinger, to adjourn the Regular Board Meeting at 7:52 pm on January 22, 2024. All of the Board Members voted for and the Motion passed.

Beth Zinsmeyer, Board President

Jennilea Campbell, Board Secretary

Board Approved _____

Medina Valley Independent School District

Special Board Meeting Expressly for the Purpose of Considering the Use of Unspent 2019 Bond Proceeds
Board Minutes
Monday, January 22, 2024, 5:30 PM
Medina Valley ISD Central Office Board Room

A Special Board Meeting Expressly for the Purpose of Considering the Use of Unspent 2019 Bond Proceeds of the Board of Trustees was held Monday, January 22, 2024, beginning at 5:30 pm at the Medina Valley ISD Central Office Board Room.

I. First Order of Business

A Call Meeting to Order

Beth Zinsmeyer, Board President, called the Medina Valley ISD Special Board Meeting to order at 5:30 pm.

B Establish a Quorum

A quorum of the Board Members were present, Matt Castiglione, Veronica Cavazos, Jennilea Campbell, Nathan Fillinger, Blane Nash and Beth Zinsmeyer. Jason Bonney was absent.

C Pledge of Allegiance to the American Flag and Texas Flag followed by a moment of silence

Everyone joined in the Pledge of Allegiance to the American Flag and the Texas Flag, followed by a moment of silence.

II. Public Comment - None

III. Discussion and Possible Action Items

A Consider Approval of Award of General Contractor for the Medina Valley High School Stadium Turf Project and Delegate Authority to the Superintendent to Negotiate and Execute the Final Contract

Matt Castiglione made a Motion, seconded by Blane Nash to Award WR Griggs the General Contractor for the Medina Valley High School Stadium Turf Project, and delegate authority to the Superintendent to Negotiate and Execute the Final Contract. All of the Board Members voted for and the Motion passed.

B Consider Approval to pay the selected contractor for the Medina Valley High School Stadium Turf Project with unspent 2019 Bond funds

Nathan Fillinger made a Motion, seconded by Veronica Cavazos, to pay the selected contractor for the Medina Valley High School Stadium Turf Project with unspent 2019 Bond Funds. All of the Board Members voted for and the Motion passed.

Medina Valley Independent School District

Special Board Meeting Expressly for the Purpose of Considering the Use of Unspent 2019 Bond Proceeds

Board Minutes

Monday, January 22, 2024, 5:30 PM

Medina Valley ISD Central Office Board Room

- C Consider Approval of the Construction Materials Observation and Testing Services for the Medina Valley High School Stadium Turf Project, with unspent 2019 Bond Funds

Matt Castiglione made a Motion, seconded by Nathan Fillinger, to approve TTL, Inc. for Construction Materials Observation and Testing Services for the Medina Valley High School Stadium Turf Project, paying with unspent 2019 Bond Funds. All of the Board Members voted for and the Motion passed.

IV. Adjournment

Veronica Cavazos made a Motion, seconded by Jennilea Campbell, to adjourn the Special Board Meeting at 5:38 pm on January 22, 2024. All of the Board Members voted for and the Motion passed.

Beth Zinsmeyer, Board President

Jennilea Campbell, Board Secretary

Board Approved _____

Medina Valley Independent School District

Special Board Meeting

Wednesday, February 7, 2024, 7:00 PM
Medina Valley ISD Central Office Board Room

A **Special Board Meeting** of the Board of Trustees was held Wednesday, February 7, 2024, beginning at 7:04 pm at the Medina Valley ISD Central Office Board Room.

I. **First Order of Business**

A Call Meeting to Order

Beth Zinsmeyer, Board President, called the Medina Valley ISD Special Board Meeting to order at 7:04 pm.

B Establish a Quorum

A quorum of the Board Members were present, Matt Castiglione, Jason Bonney, Nathan Fillinger, Blane Nash and Beth Zinsmeyer. Jennilea Campbell and Veronica Cavazos were absent.

C Pledge of Allegiance to the Flag followed by a moment of silence

Everyone joined in the Pledge of Allegiance to the American Flag and the Texas Flag, followed by a moment of silence.

II. **Public Comment - none**

III. **Discussion and Possible Action Items**

A Consider Approval of Medina Valley Independent School District Order Calling a Trustee Election for SMD # 1 and SMD #2 to be held in the May 4, 2024 General Election

Matt Castiglione made a Motion, seconded by Jason Bonney, to approve the Medina Valley Independent School District Order Calling a Trustee Election for SMD #1 and SMD #2 to be held in the May 4, 2024 General Election. All of the Board Members voted for and the Motion passed.

B Consider Approval of Medina Valley Independent School District Order Calling a Bond Election to be held in the May 4, 2024 General Election

Nathan Fillinger made a Motion, seconded by Blane Nash, to adopt an order calling a bond election to be held by the Medina Valley Independent School District with Proposition A in the amount of \$249.15 million and Proposition B in the amount of \$40.85 million, to be held in the May 4, 2024 General Election. All of the Board Members voted for and the Motion passed.

C Consider Approval of a Joint Election Agreement with Bexar County Elections

Jason Fillinger made a Motion, seconded by Matt Castiglione, to approve the Joint Election Agreement with Bexar County Elections as presented. All of the Board Members voted for and the Motion passed.

Medina Valley Independent School District

Special Board Meeting

Wednesday, February 7, 2024, 7:00 PM

Medina Valley ISD Central Office Board Room

D Consider Approval of Election Services Contract with Medina County Elections
Blane Nash made a Motion, seconded by Nathan Fillinger, to approve the Election Services Contract with Medina County Elections as presented. All of the Board Members voted for and the Motion passed.

E Consider Adoption of Resolution to join the Central Texas Purchasing Alliance
Jason Bonney made a Motion, seconded by Matt Castiglione, to adopt the resolution to join the Central Texas Purchasing Alliance as presented. All of the Board Members voted for and the Motion passed.

IV. Adjournment

Nathan Fillinger made a Motion, seconded by Jason Bonney, to adjourn the Special Board Meeting at 7:13 pm on February 7, 2024. All of the Board Members voted for and the Motion passed.

Beth Zinsmeyer, Board President

Jennilea Campbell, Board Secretary

Board Approved _____

Medina Valley Independent School District

Agenda Item Memorandum

To: MVISD Board of Trustees

Date: February 26, 2024

RE: Consider approving the purchase of 12 buses.

The Transportation Department is requesting that the Board of Trustees consider the purchase of twelve school buses from Longhorn Bus Sales. Ten Integrated CE S 72 passenger school buses at the price of \$1,434,790.00. Two Integrated CE PB110 (SPED) school buses at the price of \$286,940.00. Utilizing the Purchasing Co-Op Buy Board, this is a combined cost of \$1,721,730.00 plus a \$800 Buy Board fee. Delivery date for the buses will be in 2024-2025 fiscal year, this cost will be budgeted in the 2024-2025 budget with no impact on the current budget.

Administration recommends approval of the bus purchase with Longhorn Bus Sales.

MVISD Board Policy CH (LOCAL) Purchasing and Acquisition

10 YEAR BUS PURCHASE PLAN

OBSOLESCENCE

- 48 buses will be obsolete within the next ten years
 - 31 - 72 passenger buses
 - 12 SPED buses
 - 5 - 14 passenger buses
- 4.8 buses per year for replacement, 48 in the next ten years

GROWTH

- MVISD is expected to grow by over 10,000 students in the ten years
- Over 50 % of the student population is currently registered for Transportation
- Special education population has grown 96% in the last five years
- 2.7 buses per year for growth, 27 new buses in the next ten years

ADDITIONAL CAMPUSES

- With multiple new secondary campuses expected within the next ten years there will be an additional 5 to 10 buses in use for extracurricular activities
- 5 new buses needed for additional extra-curricular activities

SPECIALIZED ROUTES

- We currently are utilizing 4 to 5 - 14 passenger buses daily for specialized routes
- These buses do not require a CDL to drive
- With the predicted growth of our district this style bus will have a greater need
- 5 more 14 passenger buses for flexibility with specialized routes

RECOMMENDATION

- MVISD will need to purchase 85 buses in the next ten years to meet the obsolescence and growth demand
- A year by plan has been created to meet this goal

Bus Replacement Plan

School Year	72 Passenger Buses		SPED Buses		14 Passenger Buses		Total Ageing Out	Total New Needed	Total Estimated Cost
	Retire	Purchase	Retire	Purchase	Retire	Purchase	Retire	Purchase	
2024-2025	6	10	1	2	0	0	7	12	\$1.8 m
2025-2026	5	10	2	2	0	1	7	13	\$1.9 m
2026-2027	0	6	0	1	0	0	0	7	\$1.05 m
2027-2028	0	6	1	1	0	1	1	8	\$1.15 m
2028-2029	3	6	0	1	0	0	3	7	\$1.05 m
2029-2030	3	6	1	1	0	1	4	8	\$1.15 m
2030-2031	5	6	2	1	0	0	7	7	\$1.05 m
2031-2032	4	6	2	1	0	1	6	8	\$1.15 m
2032-2033	2	6	1	1	0	0	3	7	\$1.05 m
2033-2034	4	6	1	1	5	1	10	8	\$1.15 m
Total	32	68	11	12	5	5	48	85	\$12.5

Bus Replacement Plan

School Year	72 Passenger Buses	SPED Buses	14 Passenger Buses	Total Ageing Out	Total New Needed	Total Estimated Cost
-------------	--------------------	------------	--------------------	------------------	------------------	----------------------

Retire Purchase
 Retire Purchase
 Retire Purchase
 Retire Purchase



CE SCHOOL BUS

Sales Proposal For:
Medina Valley ISD

Presented By:
LONGHORN BUS SALES

Prepared For:
Medina Valley ISD
TOBIE KENNEDY
8449 F M 471 South
Castroville, TX 78009-
(830)931 - 2867

Presented By:
LONGHORN BUS SALES
FRED HOKE
9100 N LOOP E
HOUSTON TX 77029 -
(713)631-9306

Reference ID: 2 53P DSL 3P3WC

Model Profile
2025 CE SCHOOL BUS (PB110)

AXLE CONFIG: 4X2

APPLICATION: School Transportation, Special Needs

MISSION: Requested GVWR: 29800. Calc. GVWR: 30280
Calc. Start / Grade Ability: 25.86% / 2.05% @ 55 MPH
Calc. Geared Speed: 77.5 MPH

DIMENSION: Wheelbase: 217.00, CA: N/A, Axle to Frame: 126.00

ENGINE, DIESEL: {Cummins B6.7 220} EPA 2024, 220HP @ 2400 RPM, 600 lb-ft Torque @ 1600 RPM, 2600 RPM Governed Speed, 220 Peak HP (Max), School Bus Only

TRANSMISSION, AUTOMATIC: {Allison 2500 PTS} 6th Generation Controls, Wide Ratio, 6-Speed with Double Overdrive, Less PTO Provision, Less Retarder, with 33,000-lb GVW and GCW Max, School Bus

CLUTCH: Omit Item (Clutch & Control)

AXLE, FRONT NON-DRIVING: {Meritor MFS-10-122A} I-Beam Type, 10,000-lb Capacity

AXLE, REAR, SINGLE: {Dana Spicer S140} Single Reduction, 21,000-lb Capacity, 190 Wheel Ends Gear Ratio: 5.57

TIRE, FRONT: (2) 255/70R22.5 Load Range H HSR2 SA (CONTINENTAL), 565 rev/mile, 75 MPH, All-Position

TIRE, REAR: (4) 255/70R22.5 Load Range H HSR2 SA (CONTINENTAL), 565 rev/mile, 75 MPH, All-Position

SUSPENSION, REAR, AIR, SINGLE: {International IROS} 21,000-lb Capacity, 9.25" Ride Height, with Shock Absorbers Mounted Outside the Rails

PAINT: Cab schematic 100NB
Location 1: 4421, School Bus Yellow (Std)
Chassis schematic N/A

Vehicle Specifications
2025 CE SCHOOL BUS (PB110)

February 01, 2024

Code	Description
PB11000	Base Chassis, Model CE SCHOOL BUS with 217.00 Wheelbase, N/A CA, and 126.00 Axle to Frame.

BODY PLANS

47AEU	BODY, BUS Conventional; 78" Headroom, 26'8" Body Length, +9 Section Front and Rear, 59 Passenger, 217/218 WB
OBD001	BODY PLAN, SPECIAL NEEDS PLEASE USE DEALER DRAWING LHORN-2087
49000	BODY PLAN, APPROVED VARIATION None

AXLE CONFIGURATION

1ANA	AXLE CONFIGURATION {Navistar} 4x2
------	-----------------------------------

ENGINE

12EYE	ENGINE, DIESEL {Cummins B6.7 220} EPA 2024, 220HP @ 2400 RPM, 600 lb-ft Torque @ 1600 RPM, 2600 RPM Governed Speed, 220 Peak HP (Max), School Bus Only
12VJR	EMISSION, CALENDAR YEAR {Cummins B6.7} EPA, OBD and GHG Certified for Calendar Year 2024
12XCS	CARB EMISSION WARR COMPLIANCE Does Not Comply with CARB Emission Warranty
12WZE	CARB IDLE COMPLIANCE Does Not Comply with California Clean Air Idle Regulations
12WVG	EPA IDLE COMPLIANCE Low NOx Idle Engine, Complies with EPA Clean Air Regulations; Includes "Certified Clean Idle" Decal on Hood
12XCC	RADIATOR Aluminum, 2-Row, Down Flow, Front to Back System, 640 SqIn Louvered, with 383 SqIn Charge Air Cooler, Includes In-Tank Oil Cooler <u>Includes</u> : RADIATOR HOSES Premium, Rubber
12TSY	FAN DRIVE {Borg-Warner SA85} Viscous Type, Screw On <u>Includes</u> : FAN Nylon
12VCE	AIR CLEANER Single Element, Fire Retardant Media
12703	ANTI-FREEZE Red, Extended Life Coolant; To -40 Degrees F/ -40 Degrees C, Freeze Protection
12VVN	CRUISE CONTROL Electronic
12VYV	IDLE MANAGEMENT SYSTEM Ramp Engine Speed with Air Condition On, in Neutral and Parking Brake Set, Accommodation Package
12WPV	OIL PAN 15 Quart Capacity, For Cummins ISB/B6.7 Engines
12UGN	THROTTLE, HAND CONTROL Electronic

TRANSMISSION

13BBP	TRANSMISSION, AUTOMATIC {Allison 2500 PTS} 6th Generation Controls, Wide Ratio, 6-Speed with Double Overdrive, Less PTO Provision, Less Retarder, with 33,000-lb GVW and GCW Max, School Bus
13WVW	NEUTRAL AT STOP OMIT
13WYY	SHIFT CONTROL PARAMETERS {Allison} 1000 or 2000 Series Transmissions, Performance Programming
13WLN	TRANSMISSION OIL Synthetic; 20 thru 28 Pints

Vehicle Specifications
2025 CE SCHOOL BUS (PB110)

February 01, 2024

Code	Description
13WEX	TRANSMISSION SHIFT CONTROL Column Mounted Stalk Shifter, for Allison 1000 & 2000 Series Transmission

CLUTCH

11001	CLUTCH Omit Item (Clutch & Control)
-------	-------------------------------------

REAR AXLES, SUSPENSIONS

14AKC	AXLE, REAR, SINGLE {Dana Spicer S140} Single Reduction, 21,000-lb Capacity, 190 Wheel Ends . Gear Ratio: 5.57
14TDV	SUSPENSION, REAR, AIR, SINGLE {International IROS} 21,000-lb Capacity, 9.25" Ride Height, with Shock Absorbers Mounted Outside the Rails
14WAW	FLAT FLOOR EFFECTS for Air Suspension; with Conventional Bus Models

FRONT AXLES

2ASH	AXLE, FRONT NON-DRIVING {Meritor MFS-10-122A} I-Beam Type, 10,000-lb Capacity
------	---

FRONT SUSPENSIONS

3ADB	SUSPENSION, FRONT, SPRING Parabolic Taper Leaf, Shackle Type, 10,000-lb Capacity, with Shock Absorbers
	<u>Includes</u> : SPRING PINS Rubber Bushings, Maintenance-Free

CABS, COWLS, BODIES

16010	COWL Flat Back
16BAM	AIR CONDITIONER with Integral Heater and Defroster
16VKB	CAB INTERIOR TRIM Classic, for Day Cab
16GEG	GAUGE CLUSTER Premium Level; English with English Electronic Speedometer
	<u>Includes</u> : GAUGE CLUSTER DISPLAY: Base Level (3" Monochromatic Display), Premium Level (5" LCD Color Display); Odometer, Voltmeter, Diagnostic Messages, Gear Indicator, Trip Odometer, Total Engine Hours, Trip Hours, MPG, Distance to Empty/Refill for : GAUGE CLUSTER Speedometer, Tachometer, Engine Coolant Temp, Fuel Gauge, DEF Gauge, Oil Pressure Gauge, Primary and Secondary Air Pressure or Auxiliary Air Pressure (if Air Equipped) : WARNING SYSTEM Low Fuel, Low DEF, Low Oil Pressure, High Engine Coolant Temp, Low Battery Voltage (Visual and Audible), Low Air Pressure, Primary and Secondary (if Air Equipped)
16HLJ	GAUGE, DEF FLUID LEVEL
16HGH	GAUGE, OIL TEMP, AUTO TRANS for Allison Transmission
16563	HEATER SHUT-OFF VALVES (2) Ball Valve Type
16XJP	INSTRUMENT PANEL Wing Panel
16HKT	IP CLUSTER DISPLAY On Board Diagnostics Display of Fault Codes in Gauge Cluster
16VVJ	WINDSHIELD Three Piece, Bonded, with Shaded Band

FRAMES

Vehicle Specifications
2025 CE SCHOOL BUS (PB110)

February 01, 2024

Code	Description
1CAC	FRAME RAILS High Strength Low Alloy Steel (50,000 PSI Yield); 10.125" x 3.062" x 0.312" (257.2mm x 77.8mm x 8.0mm); 489.2" (12425mm) Maximum OAL
1LSG	BUMPER, FRONT Contoured, Steel, Painted Gloss Black, Severe Duty
	<u>Notes</u> : Bumper Thickness is .25"
1LNW	CROSSING GATE, FRONT Air, Yellow Blade, Bumper Mounted
	<u>Includes</u> : CONTROL ASSEMBLY Located Rear of Front Bumper, Heater not Required : CROSSING GATE, FRONT Matches Contour of Bumper
1SAL	CROSSMEMBER, REAR, AF (1)
1WHT	WHEELBASE RANGE 193" (490cm) Through and Including 217" (550cm)

BRAKES

4091	BRAKE SYSTEM, AIR Dual System for Straight Truck Applications
	<u>Includes</u> : BRAKE LINES Color and Size Coded Nylon : DRAIN VALVE Twist-Type : GAUGE, AIR PRESSURE (2) Air 1 and Air 2 Gauges; Located in Instrument Cluster : QUICK RELEASE VALVE On Rear Axle for Spring Brake Release: 1 for 4x2, 2 for 6x4 : SPRING BRAKE MODULATOR VALVE R-7 for 4x2, SR-7 with relay valve for 6x4/8x6
4AZS	AIR BRAKE ABS {Bendix AntiLock Brake System} 4-Channel (4 Sensor/4 Modulator) Electronic Stability Program, with Automatic Traction Control
4GBL	BRAKE, PARKING {Bendix Intellipark} Electronic Park Brake, for Truck or Bus Applications
4XDD	BRAKES, FRONT {Meritor 15X5 Q-PLUS CAST} Air S-Cam Type, Cast Spider, Fabricated Shoe, Double Anchor Pin, Size 15" X 5", 13,200-lb Capacity
4EXP	BRAKE CHAMBERS, FRONT AXLE {Bendix} 20 Sqli
4LAG	SLACK ADJUSTERS, FRONT {Gunite} Automatic
4XDR	BRAKES, REAR {Meritor 16.5X7 Q-PLUS CAST} Air S-Cam Type, Cast Spider, Fabricated Shoe, Double Anchor Pin, Size 16.5" X 7", 23,000-lb Capacity per Axle
4EXU	BRAKE CHAMBERS, REAR AXLE {Bendix EverSure} 30/30 Sqli Spring Brake
4LGG	SLACK ADJUSTERS, REAR {Gunite} Automatic
4SPA	AIR COMPRESSOR {Cummins} 18.7 CFM
4EDN	AIR DRYER {Bendix AD-9SI} with Heater, Includes Safety Valve
4VLE	AIR DRYER LOCATION Mounted Inside Engine Compartment, Right Side
4VLY	AIR TANK LOCATION (1) Mounted Inside & Below Left Rail, Back of Cab
4722	DRAIN VALVE {Bendix DV-2} Automatic, with Heater, for Air Tank
4WZT	GVWR LIMITATION FOR BUS with Air Brakes, Limited to 33,000-lbs Maximum to meet FMVSS 121 Requirements, for Conventional Bus
4WJP	PARKING BRAKE INTERLOCK with Electronic Park Brake, Parking Brake Cannot be Released Until Ignition Switch is in "On" Position and Service Brake Pedal is Applied, Use with Air Brake Chassis Only

STEERING

Vehicle Specifications
2025 CE SCHOOL BUS (PB110)

February 01, 2024

<u>Code</u>	<u>Description</u>
5PSA	STEERING GEAR {Sheppard M100} Power
5708	STEERING COLUMN Tilting
5CAW	STEERING WHEEL 4-Spoke; 18" Dia., Black

DRIVELINES

6DGA	DRIVELINE SYSTEM {Dana Spicer} SPL100, for 4x2/6x2
6901	PROPSHAFT GUARD

EXHAUST SYSTEMS

7BMK	EXHAUST SYSTEM Horizontal Aftertreatment System, Frame Mounted Under Right Rail, for Single Long Horizontal Tail Pipe
7SCP	ENGINE EXHAUST BRAKE for Cummins ISB/B6.7/ISL/L9 Engine with Variable Vane Turbo Charger
7WCX	HEAT SHIELD Between Exhaust & Fuel Tank, Mounted to AF Crossmember
7WBL	TAIL PIPE (1) Horizontal, Long, Exits Left Side Through Bumper

ELECTRICAL SYSTEMS

8000	ELECTRICAL SYSTEM 12-Volt, Standard Equipment <u>Includes</u> : HAZARD SWITCH Push On/Push Off, Located on Instrument Panel to Right of Steering Wheel : HEADLIGHT DIMMER SWITCH Integral with Turn Signal Lever : MISCELLANEOUS FEATURES Modular, Loom Protected, Grommets in all Applicable Body Openings, Assembled in Computer Assisted Fixture which Verifies Continuity and Correct Assembly Prior to Installation : PARKING LIGHT Integral with Front Turn Signal and Rear Tail Light : STARTER SWITCH Electric, Key Operated : TURN SIGNAL SWITCH Self-Cancelling with Lane Change Feature : TURN SIGNALS, FRONT Includes Reflectors and Auxiliary Side Turn Signals, Solid State Flashers; Flush Mounted : WINDSHIELD WIPER SWITCH 2-Speed with Wash and Intermittent Feature (5 Pre-Set Delays), Integral with Turn Signal Lever : WIRING, CHASSIS Color Coded and Continuously Numbered
8GXN	ALTERNATOR {Leece-Neville BLP4024N} Brushless, 12 Volt, 325 Amp Capacity, Pad Mount, with Remote Sense
8RPP	ANTENNA Shark Fin, Roof Mounted
8TTK	BATTERY BOX Steel, with Sliding Tray, 25.25" Wide, for Standard Batteries, 1-3 Battery Capacity, Mounted Left Side Behind Front Axle Perpendicular to Frame Rail
8MJU	BATTERY SYSTEM {Fleetrite} Maintenance-Free, (3) 12-Volt 2850CCA Total, Top Threaded Stud
8XDX	BK WARN IND,PARK BK NOT SET Visual and Audible Alarm, Active Upon Ignition Off and Parking Brake Not Set, Reminder to Set Parking Brake
8XAH	CIRCUIT BREAKERS Manual-Reset (Main Panel) SAE Type III with Trip Indicators, Replaces All Fuses
8TPL	COLLISION MITIGATION SYSTEM {Bendix Wingman Advanced} Adaptive Cruise Control with Collision Mitigation and Stationary Object Alert; Includes Front Radar, Driver Display
8WXB	HEADLIGHT WARNING BUZZER Sounds When Head Light Switch is on and Ignition Switch is in "Off" Position
8XKC	HEADLIGHTS Halogen, with Daytime Running Lights, Automatic Twilight Controlled
8WRB	HEADLIGHTS ON W/WIPERS Headlights Will Automatically Turn On if Windshield Wipers are Turned On

**Vehicle Specifications
2025 CE SCHOOL BUS (PB110)**

February 01, 2024

<u>Code</u>	<u>Description</u>
8540	HORN, ELECTRIC (2) Trumpet Style
8WWJ	INDICATOR, LOW COOLANT LEVEL with Audible Alarm
8RRC	RADIO AM/FM/USB Input/Auxiliary Input, Includes Wiring and Antenna, with Public Address System
8XKL	STARTING MOTOR {Mitsubishi Electric Automotive America 90P47} 12-Volt, with Soft-Start
8XPN	USB PORT One USB-A Port and One USB-C Port, Located in Instrument Panel

FRONT END

9WBW	FRONT END Tilting, Fiberglass, with Three Piece Construction, Dual Air Intakes
9HCY	GRILLE Molded in Black, with Chrome Surround
9WAB	HOOD TILT ASSIST {EASY TILT} Mechanical
9HBN	INSULATION, SPLASH PANELS for Sound Abatement
9HAN	INSULATION, UNDER HOOD for Sound Abatement
9AAB	LOGOS EXTERIOR Model Badges
9AAE	LOGOS EXTERIOR, ENGINE Badges

SPEEDOMETER, TOOLS, MISC

10020	CHASSIS PAINT Full Chassis
10AGB	COMMUNICATIONS MODULE Telematics Device with Over the Air Programming; Includes Five Year Data Plan and International 360
10WUE	MUD FLAPS, FRONT WHEELS (2) Rubber, Mounted on Fender Extension
10060	PAINT SCHEMATIC, PT-1 Single Color, Design 100 <u>Includes</u> : PAINT SCHEMATIC ID LETTERS "NB"
10788	PAINT TYPE Urethane, One or Two Colors, Other than Imron or International.
10XAK	PROMOTIONAL PACKAGE 7 Year Unlimited Miles/km Warranty, Limited Time Program for Allison 2500 Series Transmission on School and Commercial Buses (Supplied directly through Allison)

FUEL TANKS

15SLK	FUEL TANK Top Draw, Steel, Rectangular, 65 US Gal (246L), Includes Protective Cage, Mounted Between Frame Rails and Behind Rear Axle
15WEP	DEF TANK 16.5 US Gal (62.5L) Capacity, Frame Mounted Outside Right Rail, Behind 0 Bow
15LMR	FUEL/WATER SEPARATOR {Racor 400 Series,} with Primer Pump, Includes Water-in-Fuel Sensor
15LRE	LOCATION FUEL/WATER SEPARATOR Mounted Under Hood, Left Side, Above Front Axle

WHEELS, TIRES - FRONT

27DUW	WHEELS, FRONT {Accuride 51408} DISC; 22.5x8.25 Rims, Powder Coat Steel, 2-Hand Hole, 10-Stud, 285.75mm BC, Hub-Piloted, Flanged Nut, with Steel Hubs
7752525421	(2) TIRE, FRONT 255/70R22.5 Load Range H HSR2 SA (CONTINENTAL), 565 rev/mile, 75 MPH, All-Position

WHEELS, TIRES - REAR

**Vehicle Specifications
2025 CE SCHOOL BUS (PB110)**

February 01, 2024

Code	Description
28DUW	WHEELS, REAR {Accuride 51408} DUAL DISC; 22.5x8.25 Rims, Powder Coat Steel, 2-Hand Hole, 10-Stud, 285.75mm BC, Hub-Piloted, Flanged Nut, with Steel Hubs
7752525421	(4) TIRE, REAR 255/70R22.5 Load Range H HSR2 SA (CONTINENTAL), 565 rev/mile, 75 MPH, All-Position

WHEELS, SPARE

26DUW	WHEEL, SPARE, DISC {Accuride 51408} 22.5x8.25 Rims, Powder Coat Steel, 10-Stud, 285.75mm BC, Hub-Piloted
-------	--

BODY FEATURES

47BAK	BUMPER, REAR Painted, 12" High, 3/16" Thick
47BAR	SUPPORTS, REAR BUMPER Bolted to Frame
47AYB	BODY, REAR Includes Emergency Door
47ARH	BOWS, ROOF 14 ga., One Piece Construction
	<u>Includes</u> : BOWS, ROOF Positioned Floor Line to Floor Line, Threaded Through Roof Strainers and Drip Rail
47BLU	FASTENERS, EXTERIOR MOUNTED Stainless Steel Screws; for All Exterior Body Lights, Body Exterior Rear View Mirrors, Bumper Mounted Crossing Gate and Body Mounted Stop Arms
47APX	FASTENERS, HEADLINER Screws
47AZK	FLOOR, BODY Flat
47PBZ	HANDLE, ASSIST Windshield Side Mounted, Left and Right, Body Color
47APR	HEADLINER, BODY Conventional; 25'11"-35'08" Body Length, Perforated Full Length with Sound Insulation Full Length
47ARP	LIGHT BARS Plastic
47BBH	LINING, SIDE INTERIOR, LOWER Embossed Steel, Clear Coated
47AXR	RUB RAILS, BODY (4) Conventional; Steel, 25'2", 25'11", 26'8", 27'5" Body Length, Includes Snow Rail
	<u>Includes</u> : RUB RAILS Full Length, Primer Coated (Both Sides), Attached to Body without Cuts or Splices
47BBZ	SEALER Extra; Sidewall to Floor, In Wheel Pocket Area, and Rear Wall to Floor
47AZC	SIDE SHEET, BODY, EXTERIOR Conventional, 16ga., Smooth, 25'2", 25'11", 26'8", 27'5", Body Length
47ASG	SKIRT, BODY for Conventional, 14 1/2", 16ga
	<u>Includes</u> : SKIRT, BODY Extra Smooth Steel Supported by Floor Gussets
47BLE	STEP, FRONT ENTRANCE DOOR 25 3/4" Depth; 14ga Steel, Formed Treads, Naviflex Finish
47AUR	TIE DOWNS, BODY Grade 8 Bolts, Every Body Section
	<u>Includes</u> : TIE DOWNS, BODY with Formed Tab that Fits into Floor Structure to Prevent Turning
47DAJ	COVER, REAR DOOR INSIDE HANDLE Partial Coverage
47DYL	DOOR, ENTRANCE, FRONT Air, Outward Opening, with Single Pane Glass
47DWP	DOOR, LIFT Single, 43" x 69.79", Mounted Aft of Rear Wheel Pocket, with 78" Headroom
47DAK	FASTENERS, REAR DOOR Bolts and Nutserts, Rear Door To Body

Vehicle Specifications
2025 CE SCHOOL BUS (PB110)

February 01, 2024

Code	Description
47DDE	HANDLE, ASSIST, ENTRANCE DOOR Outside Entrance
47DCW	HANDLE, EXTERIOR, LIFT DOOR Single Door, Yellow
47DEY	HANDLE, EXTERIOR, REAR Emergency Door; Yellow
47DDH	HOLD BACK, REAR DOOR Stationary, No Cables, with Plastic Cover
47DDR	LATCH, LIFT DOOR Single, Three Point Slide Bar
47DDU	LATCH, REAR DOOR One Point Slide Bar, Cam Operated, with One Inch Stroke
47EYL	LOCK, ENTRANCE DOOR in External Release, with Key
47DEK	LOCK, REAR DOOR with Ignition Starter Interlock
47DEV	LOCK, SINGLE LIFT DOOR with Ignition Starter Interlock
47EHA	CARTON, SHIPPING Carton for Spare Wheel Only, Inside Bus
47BDJ	COMPARTMENT, DRIVER STORAGE Bin, Sized to Hold Three Ring Binder, Includes (1) USB-A Port and (1) USB-C Port
47EBM	HOLD DOWN, BATTERY For Up To 3 Batteries
47BMA	WASTE CONTAINER Removable, Located in Driver Area
47LAU	INSULATION, ROOF/SIDES/BULKHEAD 1.5"
47LAR	NOISE REDUCTION, ROOF BOW Conventional; Insulation, 25'2", 25'11", 26'8", 27'5" Body Lengths
47MBA	UNDERCOAT, BODY Fire Resistant, Water Based, TT-C-730 Spec
	<u>Includes</u> : UNDERCOATING Performed Before and After Mounting on Chassis
47SPC	ALPHA/NUMERIC DECAL GUIDE Quantity 031-40
47AJA	BODY CERTIFICATION TAG Metal
47APJ	BODY RATING TAG Metal; for State of Texas, Includes Design Capacity and Seat Capacity
47AJC	BODY TAG, METAL Capacity to Include the Total Number of Passengers
47AKZ	DECAL, HANDICAP (4) 6" x 6", 1 Mounted on Electrical Access Door, 1 Mounted on Lift Door Below Window Line, 1 on Left Bumper, 1 on Rear Door Between Top and Bottom Glass
47PLX	LETTERS, DEF, I.D. Decal; "DEF ONLY", 1" Black, on DEF Filler Door
47MJR	LETTERS, DOOR, REAR Decals; "EMERGENCY DOOR", 2" Black Letters Inside and Outside
47NGP	LETTERS, FUEL I.D. Paint; "DIESEL FUEL", 2" Black, Adjacent to Fuel Filler Door
47MVA	LETTERS, HEADER Decal; "WATCH YOUR STEP", 1" Black, Above Windshield
47MRU	LETTERS, E/E WINDOW, LEFT (2) Decal Sets, "EMERGENCY EXIT", Black Inside and Outside
47NHL	LETTERS, E/E WINDOW, RIGHT (2) Decal Sets, "EMERGENCY EXIT", Black, Inside and Outside
47MAV	LETTERS, SCHOOL BUS SIDE Decal; "SCHOOL BUS"; in 8" Reflective Black Letters, Each Side
47BKK	LETTERS, SCHOOL BUS FRONT/REAR Decal; "SCHOOL BUS"; with 8" Black Reflective Letters, 3M Fluorescent Diamond Grade, Yellow On Front and Rear Cap
47MVC	LETTERS, STEPWELL Decal, "WATCH YOUR STEP", 2.5" Black, Behind Door on Step Riser
47NTE	LOGO, ROOF LINE Decal; Wing and Shield, First Body Section, Above Driver Window and Entrance Door Over Driver Window and Entrance Door

Vehicle Specifications
2025 CE SCHOOL BUS (PB110)

February 01, 2024

Code	Description
47NMG	OPERATING INSTRUCTIONS, REAR Decal, Inside Rear Emergency Door
47NKM	PAINT COLOR, BODY INTERIOR 9384 Spring White
47NJA	PAINT COLOR, BODY EXTERIOR 4421 School Bus Yellow
47NJS	PAINT COLOR, BUMPER Rear, 0001 Canyon Black
47NJM	PAINT FLASHER BACKGRD 0001 Canyon Black
47NTY	PAINT HOOD AND FENDER To Match Body Exterior
47NKD	PAINT COLOR, ROOF 9219 Winter White, Beginning 5" Above Drip
47NKL	PAINT, RUB RAIL Flange to Flange
47NAB	PAINT COLOR, RUB RAILS 0001 Canyon Black
47NGW	SEAL, RUB RAILS Top Edge, All Rails
47MRN	STRIPING, E/E WINDOW, LEFT (02) Perimeter, 1" Yellow
47MUP	STRIPING, E/E WINDOW, RIGHT (02) Perimeter, 1" Yellow
47MSA	STRIPING, PERIMETER, REAR Emergency Door, 1" Yellow Reflective
47MVM	STRIPING, REAR END 1" Yellow
47MSJ	STRIPING, ROOF HATCH, FRONT Decal, Perimeter, 1" Yellow
47MSK	STRIPING, ROOF HATCH, REAR Decal, Perimeter, 1" Yellow
47MSS	STRIPING, SEATLINE 2" Yellow
47MTY	WIRING DIAGRAM Schematic, Electrical
	<u>Includes</u> : ACCESS PANEL for Wiring Diagram Schematic Located on Inside of Electrical Panel Door, Below Driver Window
47SAZ	SUB FLOOR, PLYWOOD Conventional; B-B Marine Grade, Less Sealed Edges, 5/8", 5 Ply, for 25'2",25'11", 26'8" or 27'5" Body Lengths
47KEJ	DISARM, POST TRIP INSPECTION Button Located on Light Bar at Rear of Bus
47KEB	MONITOR, POST TRIP INSPECTION {Leave No Student Behind} Accessory Controlled, with Push Button Alarm Disable at Rear of Bus Prompts Driver to Walk to Back of Bus to Disable Alarm
47DNK	SWITCH, LOCATION Steering Wheel; Includes Master Flasher, Flasher On/Off, Red Override, and Door Control
	<u>Includes</u> : SWITCH, STEERING WHEEL, LIGHT Includes Illuminated Switches

BODY FEATURES

48ANT	WINDOW, DRIVER Laminated, Clear
48BJA	COLOR, WINDOW FRAME, PASS Passenger Window, Natural Aluminum Finish
48BAH	WINDOW, E/E, LEFT (2) Vertical Hinge
48BKP	WINDOW, E/E, RIGHT (2) Vertical Hinge
48AUL	WINDOW, PASSENGER, TINT Conventional; 28% Light, Laminated Glass, 78" Headroom, with 25'2", 25'11", 26'8", 27'5" Body Lengths
48ARD	WINDOW, SASH (9) 27" Sections, 9"x 23" Opening

Vehicle Specifications
2025 CE SCHOOL BUS (PB110)

February 01, 2024

<u>Code</u>	<u>Description</u>
48ASR	WINDOW, SASH +9 SECTIONS (3) 9" x 32 1/4" Opening
48APL	WINDOW, STOPS 12" Opening, Only with 78" Headroom
48PAY	AISLE POSITION Center, for balanced seating
48PBB	FLOOR COVERING, COLOR Black
48PJR	FLOOR COVERING, TRIM Aluminum
48PJZ	FLOOR COVERING, TYPE {Koroseal} All Body Lengths
48VVR	STEP TREADS {Koroseal} Pebble White Nosing Only, with Non-Metal Backing, used with Formed Treaded Steps
48PKC	HOSE CLAMPS, HEATER HOSE Constant Torque for Heater System
48UZK	FAN, DEFOG LEFT OF DRIVER 6.50" Diameter, Black, Mounted on Driver Overhead Compartment, 2 Speed Switch in Panel
48GNW	FAN, DEFOG RIGHT CENTER 6.50" Diameter, Black, Mounted Over Windshield, 6" Right of Centerline, 2 Speed Switch in Panel
48PPP	HEATER CUT OFF, VALVE INSIDE Brass Ball, Inside Driver Area
48UYC	HEATER, REAR WALL, RT SIDE 80,000 BTU
48PNW	HEATER, WATER PUMP {2 MPU 12} Self Priming, with Plastic Housing
48UZN	ROOF HATCH, FRONT {Specialty Hybrid Adv H1975-025-191-0F} Emergency Exit with Outside Release, Alarm, English Decals
48UZT	ROOF HATCH, REAR {Specialty Hybrid Adv H1975-025-191-0F} Emergency Exit with Outside Release, Alarm, English Decals
48PPS	ROOF VENT, FRONT Static
48TMY	SEAT, DRIVER {National 2000} Air Suspension Dual Shock, High Back with Integral Headrest, Isolated, with 2 Position Front Cushion Adjustment, 6 to 17 Degree Seat Back Adjustment, Mechanical Lumbar Support, Includes Additional Back Padding
	<u>Includes</u> : SEAT BELT, DRIVER Adjustable D-Loop Seat Belt, Single Locking Retractor
48XPX	UPHOLSTERY, BARRIER, TYPE (1-2) Prevaill, 42 oz.
48PVN	UPHOLSTERY, DRIVER SEAT, COLOR Drivers Seat, Gray
48PVA	UPHOLSTERY, DRIVER SEAT, STYLE Plain, with Cloth Insert
48PWR	UPHOLSTERY, DRIVER SEAT, TYPE Prevaill, 42 oz.
48BDS	BARRIER, CRASH, AFT ENTRY DOOR 39", 2 Leg
48RAL	BARRIER, CRASH, AFT DRIVER 39", 1 Leg
48UZX	HAND RAIL, ENTRANCE DOOR, AFT Dual Height Stainless Steel, Upper Rail 1.25" OD 28" Above Floor, Lower Rail 1" OD
48UZY	HAND RAIL, ENTRANCE DOOR, FWD Dual Height Stainless Steel, Upper Rail 1.25" OD 28" Above Floor, Lower Rail 1" OD
48RET	PANEL, MODESTY, AFT ENTR DOOR Mounted Under Barrier
48REP	PANEL, MODESTY, AFT OF DRIVER Mounted Under Barrier
48ACN	SEAT BELT, DRIVER, COLOR with Blaze Orange Seat Belt Webbing

Vehicle Specifications
2025 CE SCHOOL BUS (PB110)

February 01, 2024

Code	Description
48USV	SEAT BACK, PASSENGER High Back
48YYE	SEAT,39",TRK,3PT,LT {IMMI Seats SBR-U} (04) with 3 Point Seat Belts
48YZR	SEAT,39",TRK,3PT,RT {IMMI Seats SBR-U} (02) with 3 Point Seat Belts
48XZZ	SEAT,39",WALL,3PT,LT {BTI Seating System} (5) High Back, with 3 Point Seat Belts
48YAN	SEAT,39",WALL,3PT,RT {BTI Seating System} (5) High Back, with 3 Point Seat Belts
48PWD	UPHOLSTERY, PASS SEATS, COLOR Gray, for Seats, Barriers and Head Bumpers
48PHK	UPHOLSTERY, PASS SEATS, TYPE Prevaill, 42 oz.; for (15-16) Seats
48RLX	CUSHION, SEAT 15" Depth
48RRA	UPHOLSTERY, SEAT, STITCHING Single

BODY FEATURES

48HAC	WINDOW, ENTRANCE DOOR Laminated, Clear, with Single Piece Glass
49HGA	TRACK, FLOOR LENGTHS 151"-200", with Full Shoulder Track
49JBG	TRACK, TYPE (BRAND) {OMNI L Track}
49AMJ	ALARM, BACKING {Ecco #575} 107 dB
49AMT	CIRCUIT, PROTECTION Breakers, Manual Reset in Lieu of Fuses
49BCN	FLASHER SYSTEM (8) Warning Lights, 8-Lamp System, Electronic Relay Flasher, Non-Sequential Operation, Red Lights Activate with Door Open
49DBR	HOOD, WARNING LAMP (4) Black, 8-Lamp System, One Hood Above Two Lights
49JBU	LIGHT, ENTRY DOOR {Sound Off/OptiLuxx} LED; 4" Oval; Light Mounted in Skirt Behind Entrance Door, Wired To Step Light
49BCR	LIGHT, EXTERIOR, CHECK Automatically Activates Lights for Pre Trip Inspection
49ATJ	LIGHT, INDIC, LIFT DOOR Amber; Flashing, Located in Driver Area
49ATV	LIGHT, INDIC, WARNING LIGHTS Red and Amber
	<u>Includes</u> : LIGHTS, WARNING Indicator Located in Instrument Cluster
49JBV	LIGHT, LICENSE PLATE {Sound Off/OptiLuxx} LED, with Mounting Gasket
49BZC	LIGHT, LIFT DOOR, INTERIOR Above Lift Door, Rectangular LED, with Door Operated Switch (Functionality May Be Included in Existing Dome Light)
49JBW	LIGHT, STEP {Sound Off/OptiLuxx} 4" Round LED, White, Wired to Clearance Lights, Operated by Entrance Door
49EYH	LIGHT, STROBE LED, Specialty Man. Co. 845-4020-100, Low Profile, Double Flash, 4.50" High
49ZNC	LIGHTS, BACK UP (2) {Sound Off/OptiLuxx} 4" Round, White, LED, with Flange
49JBS	LIGHTS, CLUSTER {Sound Off/OptiLuxx} Oval, 4 Internal LEDs per Light; Amber Front and Red Rear
49BYZ	LIGHTS, DIRECTIONAL, REAR (2) {Sound Off/OptiLuxx} LED, 7" Round Amber
49EAX	LIGHTS, DIRECTIONAL, SIDE (4) {Sound Off/OptiLuxx} Rectangular LED Armored, 2 Each Side First Section Aft Entrance Door & Forward Rear Wheel Pocket
49JEN	LIGHTS, DOME LED, Rectangular Recessed Type, Stagger Mounted, for 25'02", 25'11", 26'08", 27'05", 28'02", 28'11" Body Lengths

Vehicle Specifications
2025 CE SCHOOL BUS (PB110)

February 01, 2024

Code	Description
49ESC	LIGHTS, DOME, DRIVER (1) LED, Rectangular, Mounted in Light Bar in Ceiling, with Separate Switch
49JED	LIGHTS, MARKER, FRONT & REAR LED, Flush Mount, Amber Front and Red Rear
49ZNN	LIGHTS, MARKER, SIDE, INTERMED LED, Amber, Flush Mount, Intermediate, Centered, Required for Units 30 Foot or Longer
49BYT	LIGHTS, STOP (2) {Sound Off/OptiLuxx} and Tail; 7" Round LED, Red
49ZNG	LIGHTS, STOP & TAIL ADDITIONAL (2) {Sound Off/OptiLuxx} 4" Round LED, Red, with Flange
49NGJ	LIGHTS, WARNING (8) {Sound Off/OptiLuxx} (4) 7" Round Red Strobing LED and (4) 7" Round Amber Strobing LED, 2 Front, 2 Rear Each Color
49AWT	SPEAKERS AND WIRING (4) Flush Mounted in Light Bar
49ELC	STOP ARM, FRONT Electric, Composite Blade, 18" Octagon, Double Sided, 1/2" White Border, Hi Intensity Grade, Strobing LED Lights
49ELG	STOP ARM, LEFT REAR Electric, Composite Blade, 18" Octagon, Single Sided, 1/2" White Border, Hi Intensity Grade, Strobing LED Lights
49BSL	SWITCH, DOME LIGHTS, DIMMER for All Passenger Dome Lights
49SAA	SWITCH, INSTRUMENT PANEL LIGHTS; Rheostat
49EVL	SWITCH, NOISE SUPPRESSION Actuator Legend States, "NOISE SUPP ", for Separate Solenoid, with Red Switch in Panel
49AMY	SWITCH, REAR DOOR BUZZER for Emergency Door
49BXN	SWITCH, RED, OVERRIDE WARNING Wired Hot, with ESC, Mounted Left of Driver
49BUS	WIRING, WARNING LIGHTS (8) for 7" Red Warning Lights, Alternately Flashing, 2 Front, 2 Rear, Red Warning Lights to Operate When Lift Door is Open and Master Flasher Switch is "ON"
49EGL	MIRROR, CROSS VIEW, EXTERIOR (2) {Rosco Mini Hawk-Eye} Black <u>Includes</u> : MIRROR MOUNT Attached to Body with Metal Backing Plates
49EGB	MIRROR, INSIDE 10" x 30", Clear
49DNB	MIRROR, REAR VIEW, EXTERIOR {Rosco AccuStyle} Black, Motorized Head, Heated, Breakaway Bracket
49ENK	VISOR, INTERIOR, LEFT FRONT 6" x 30", Transparent, For Left Windshield
49GDS	COMPARTMENT ABOVE DRIVER Left of the Driver <u>Includes</u> : COMPARTMENT ABOVE DRIVER Compartment Size: 39" x 10" x 10" : HINGES Piano Type
49GGW	FIRE BLANKET Deist, in Storage Container, 1st Bow Section From Rear
49JGJ	FIRE EXTINGUISHER 5 lb 3A-40BC Minimum, with Flexible Hose and Metal Nozzle
49JGN	FIRE EXTINGUISHER, FRONT LOC Located Behind Driver Seat
49GAY	KIT, BODY FLUID Texas
49EBA	KIT, FIRST AID Plastic; 24 Unit, Spec State
49MZV	LATCH, COMPARTMENT Locking, for Overhead Storage Compartment
49JEY	LOCATION, BODY FLUID KIT on Bulkhead
49GCH	LOCATION, FIRST AID KIT Right Side Front Bulkhead with Screws

Vehicle Specifications
2025 CE SCHOOL BUS (PB110)

February 01, 2024

Code	Description
49GDG	PADDING COMPART ABOVE DRIVER Window; Safety Equipment Compartment, with Cutout for Dome Light
49GLP	REFLECTORS, REAR (2) 3", Red, Mounted with Screws
49GLM	REFLECTORS, SIDE, FRONT (2) 3", Amber; 1 Aft Drivers Window Left, 1 Aft Entrance Door Right, Mounted with Screws
49GLA	REFLECTORS, SIDE, INTERMEDIATE (2) 3" Amber, 1 Each Side, Mounted with Screws, Below The Third Rub Rail From the Top
49GLG	REFLECTORS, SIDE, REAR (2) 3", Red, Mounted with Screws
49GED	SAFETY TRIANGLES Warning Reflectors, Mounted on Floor Between Driver Seat and Drivers Crash Barrier/ Stanchion/Partition
49GPH	STORAGE COMPARTMENT, BELTS (3) for Sure Lok Wheelchair Belts, Mounted to Wall
49GMM	INTERLOCK, LIFT for FMVSS Wheel Chair Interlock Requirements; Key Off, Lift Door Must be Open before Lift can be Activated, w/ Key in "On or Accessory" Position, Park Brake Must be Applied, Transmission in Neutral, Lift Door Must be Open Before Lift Can be Activated, w/ Automatic or Procision Transmissions
49NAB	LIFT, WHEELCHAIR {Braun Model NCL1000FIB3451 Gen 2} Power Pack Mounted Forward of Lift
49JCC	TIE DOWN, WHEELCHAIR {Sure-Lok AL812S-4C-7} Titan System, (03) Forward Facing, 50" Floor Space Front To Rear Required, Tie Down Only
49EPY	CUTTER, SEAT BELT (2) {TIE TECH Safecut} for Cutting Seat Belts
49JGE	CUTTER, SEAT BELT, LOCATION Mounted on Panel Left of Driver
49JAC	DEF FILLER DOOR with Non-Locking Latch
49MZS	FUEL FILLER DOOR Non-Locking, Lever Latch, Spring Loaded to Hold in Open Position
49CKT	FUEL FILLER PIPE Low Profile Neck Cap and Vent Hosing, for Use with Right Side Fill for Between the Rail Fuel Tanks, for Above the Floor Fuel Fill, for 25 GPM Fill Rate Only
49GUM	INSPECTION PLATE Fuel Sending Unit 8" x 8" Steel
49GVC	MUD FLAPS, REAR WHEELS (2) Rubber
49UBZ	STATE OF OPERATION Texas

Services Section:

WARRANTY

40126	WARRANTY Standard for CE, RE, BE School Bus Models, Effective with Vehicles Built March 1, 2017 or Later, CTS-3304H
40YET	SERVICES, TOWING {Navistar} Service Call to 24-Month/Unlimited Mileage to the Nearest IC Bus Dealer for Navistar Warrantable Failure as Contract Defined; Includes Engine Failure if Supplier Declines Tow Coverage & ESC Supplied thru Navistar; \$1100 (USA) Maximum Benefit per Incident
40YGC	SRV CONTRACT, EXT VEH COVERAGE {Navistar} To 24-Month/50,000 Miles (80,000 km), Covers 100% Parts and Labor; Includes Body; Excludes Extending Warranty for Engine, Transmission, Perforation or Corrosion of Cab/Cowl Structure and Paint

BODY FEATURES

49GVN	WARRANTY 5-Year, Limited
	SET GOVERNOR SPEED 55 MPH

Vehicle Specifications
2025 CE SCHOOL BUS (PB110)

February 01, 2024

Code

Description

WEIGHT SLIP

PRE DELIVERY INSPECTION CE MODEL

STATE INSPECTION

AC - 126KBTU BERGSTROM - FRONT & REAR INWALL EVAPS (FACTORY INSTALLED DASH AC) LHB
INSTALL

SEON 5 CAM SYS, GPS, WIFI, INSTALLED - LHB

BUYBOARD FEE DIVIDED ACROSS (2) TWO BUSES

**Financial Summary
2025 CE SCHOOL BUS (PB110)**

February 01, 2024

<u>Description</u>	<u>(US DOLLAR)</u>	<u>Price</u>
Net Sales Price:		\$286,940.00

Prices are good for 30 days from the date of this proposal.

PRICE PER BUS: \$143,470.00

PRICE FOR (2) TWO BUSES: \$286,940.00

This quote would be produced as a 2025MY product if awarded. Feature codes are subject to update upon IC Bus completion of code references. Estimated delivery: 300-365 Days from receipt of a purchase order. Longhorn Bus Sales will not be held responsible for material shortages or delays due to the global COVID-19 pandemic or any other reasons outside of our control, that of the represented OEM (IC Corp) or third-party vendors used to complete a customers' bus order. Any buses ordered, will be subject to any and all applicable surcharges at the time of build, due to the volatility of the producers material costs. Any applicable surcharges will be the responsibility of the buyer. A bus order may be delivered without OEM or third-party products (i.e., A/C, GPS, two-way radios, camera surveillance equipment, etc.), and any such items will be installed immediately upon availability. These shortages/delays will not hold up invoicing and or payment. Instructions for payment of invoices will be provided upon invoicing. No one from Longhorn Bus Sales will ever contact or email wiring or ACH instructions for payment. Due to industry constraints, quote pricing may fluctuate.

Buy Board contract 722-23.

40YGC Warranty: Longhorn Bus Sales will cover the warranty for 24-months/unlimited mileage. (Navistar will cover the first 50K miles. Longhorn Bus will cover 50K+ miles, up to the ending of the 24-month period, as per current Texas School Bus Specifications.

CODE "49GVN WARRANTY 5-YEAR, LIMITED" IS A NAVISTAR WARRANTY ONLY, IT DOES NOT APPLY TO ANY AFTERMARKET PARTS

By signing this document in acceptance of an order, the customer acknowledges that all equipment listed within this document is correct. Longhorn Bus Sales will not be responsible for any miss-built units. Any changes to what is listed herein, may result in additional charges to the order. Thank you.

Approved by Seller:

Accepted by Purchaser:

LHB Sales 02/02/2024

Official Title and Date

Frederick A. Hoke, Jr.
Authorized Signature

Firm or Business Name

Authorized Signature and Date

This proposal is not binding upon the seller without Seller's Authorized Signature

Official Title and Date

The TOPS FET calculation is an estimate for reference purposes only. The seller or retailer is responsible for calculating and reporting/paying appropriate FET to the IRS.

The limited warranties applicable to the vehicles described herein are Navistar, Inc.'s standard printed warranties which are incorporated herein by reference and to which you have been provided a copy and hereby agree to their terms and conditions.

BODY PLAN

WHEELBASE 218"

PB11000, 26 FT. 8 IN., CAP 48

FLAT FLOOR

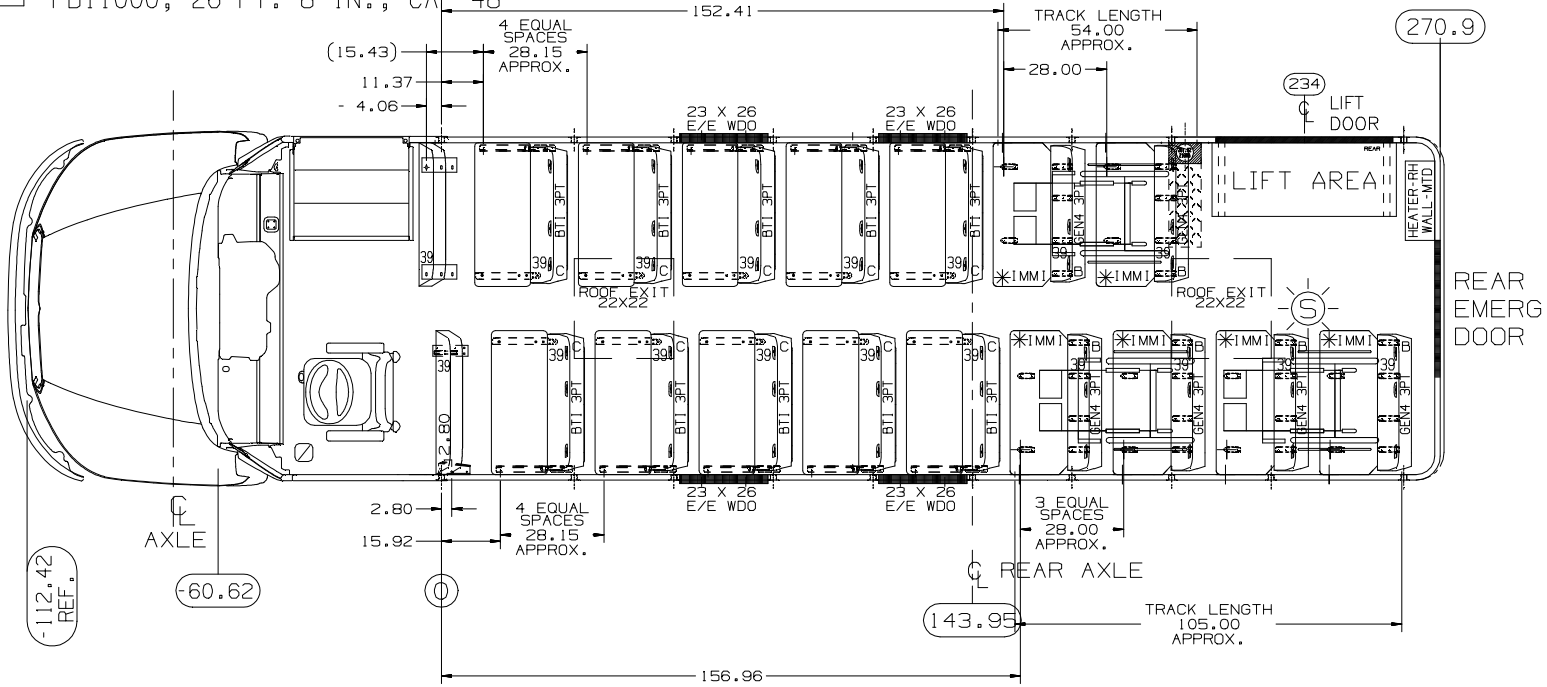

* 159" TOTAL TRACK LENGTH (APPROXIMATELY)

OK	DATE	CHANGE	REV	REFERENCE
----	------	--------	-----	-----------

50000/49000

REVISE ONLY ON UOPRAF SYSTEM

<p>INTERNATIONAL TRUCK AND ENGINE CORPORATION INTERNATIONAL CONFIDENTIAL PROPRIETARY</p>		REFERENCE	000		
		L INEAR MEASURE: <input type="checkbox"/> mm <input checked="" type="checkbox"/> in	APPROX. MASS (WEIGHT) ROUGH PART FINISH PART		
ONE PLACE 1.,X1	+1.5	+0.06		INTERNAL CONTROL	
TWO PLACE 1.,XX1	+0.18	+0.03			
THREE PLACE 1.,XXX1	+0.25	+0.010			
ANGLES	+1°				
NAME		BODY PLAN PB11000		CONTROL	E 50
NAME (TRANSLATION)				VERSION	E
DRWN	U020270	MATERIAL		APPROVE	
DATE	22FEB23			DATE	
DESIGN					
DATE					
APPROVED		PTR NOUN CODE	PART TYPE CODE	SCALE	4
DATE				NONE	
RELEASE NO.		PART NO.	LHORN-2087		SHEET
					01

THIS UNIT CONFORMS TO APPLICABLE FMVSS/CMVSS/D250 THIS DOCUMENT IS IN ACCORDANCE WITH ASME Y14.5M-1994 AS AMENDED BY THE INTERNATIONAL TRUCK DIVISION DIMENSIONING AND TOLERANCING ADDENDUM-2000.

Request for Taxpayer Identification Number and Certification

**Give Form to the
requester. Do not
send to the IRS.**

▶ Go to www.irs.gov/FormW9 for instructions and the latest information.

Print or type.
See Specific Instructions on page 3.

<p>1 Name (as shown on your income tax return). Name is required on this line; do not leave this line blank. LONGHORN BUS SALES, LLC</p> <p>2 Business name/disregarded entity name, if different from above</p> <p>3 Check appropriate box for federal tax classification of the person whose name is entered on line 1. Check only one of the following seven boxes.</p> <p> <input type="checkbox"/> Individual/sole proprietor or single-member LLC <input type="checkbox"/> C Corporation <input type="checkbox"/> S Corporation <input type="checkbox"/> Partnership <input type="checkbox"/> Trust/estate <input checked="" type="checkbox"/> Limited liability company. Enter the tax classification (C=C corporation, S=S corporation, P=Partnership) ▶ C <small>Note: Check the appropriate box in the line above for the tax classification of the single-member owner. Do not check LLC if the LLC is classified as a single-member LLC that is disregarded from the owner unless the owner of the LLC is another LLC that is not disregarded from the owner for U.S. federal tax purposes. Otherwise, a single-member LLC that is disregarded from the owner should check the appropriate box for the tax classification of its owner.</small> <input type="checkbox"/> Other (see instructions) ▶ </p> <p>5 Address (number, street, and apt. or suite no.) See instructions. 9100 NORTH LOOP EAST</p> <p>6 City, state, and ZIP code HOUSTON, TEXAS 77029</p> <p>7 List account number(s) here (optional)</p>	<p>4 Exemptions (codes apply only to certain entities, not individuals; see instructions on page 3):</p> <p>Exempt payee code (if any) _____</p> <p>Exemption from FATCA reporting code (if any) _____</p> <p><small>(Applies to accounts maintained outside the U.S.)</small></p> <p>Requester's name and address (optional)</p>
--	--

Part I Taxpayer Identification Number (TIN)

Enter your TIN in the appropriate box. The TIN provided must match the name given on line 1 to avoid backup withholding. For individuals, this is generally your social security number (SSN). However, for a resident alien, sole proprietor, or disregarded entity, see the instructions for Part I, later. For other entities, it is your employer identification number (EIN). If you do not have a number, see *How to get a TIN*, later.

Note: If the account is in more than one name, see the instructions for line 1. Also see *What Name and Number To Give the Requester* for guidelines on whose number to enter.

Social security number									
or									
Employer identification number									
2	0	-	0	5	3	8	1	3	6

Part II Certification

Under penalties of perjury, I certify that:

- The number shown on this form is my correct taxpayer identification number (or I am waiting for a number to be issued to me); and
- I am not subject to backup withholding because: (a) I am exempt from backup withholding, or (b) I have not been notified by the Internal Revenue Service (IRS) that I am subject to backup withholding as a result of a failure to report all interest or dividends, or (c) the IRS has notified me that I am no longer subject to backup withholding; and
- I am a U.S. citizen or other U.S. person (defined below); and
- The FATCA code(s) entered on this form (if any) indicating that I am exempt from FATCA reporting is correct.

Certification instructions. You must cross out item 2 above if you have been notified by the IRS that you are currently subject to backup withholding because you have failed to report all interest and dividends on your tax return. For real estate transactions, item 2 does not apply. For mortgage interest paid, acquisition or abandonment of secured property, cancellation of debt, contributions to an individual retirement arrangement (IRA), and generally, payments other than interest and dividends, you are not required to sign the certification, but you must provide your correct TIN. See the instructions for Part II, later.

Sign Here	Signature of U.S. person ▶ <i>Ashley Schrader</i>	Date ▶ <i>01/05/2024</i>
------------------	---	--------------------------

General Instructions

Section references are to the Internal Revenue Code unless otherwise noted.

Future developments. For the latest information about developments related to Form W-9 and its instructions, such as legislation enacted after they were published, go to www.irs.gov/FormW9.

Purpose of Form

An individual or entity (Form W-9 requester) who is required to file an information return with the IRS must obtain your correct taxpayer identification number (TIN) which may be your social security number (SSN), individual taxpayer identification number (ITIN), adoption taxpayer identification number (ATIN), or employer identification number (EIN), to report on an information return the amount paid to you, or other amount reportable on an information return. Examples of information returns include, but are not limited to, the following.

- Form 1099-INT (interest earned or paid)

- Form 1099-DIV (dividends, including those from stocks or mutual funds)
 - Form 1099-MISC (various types of income, prizes, awards, or gross proceeds)
 - Form 1099-B (stock or mutual fund sales and certain other transactions by brokers)
 - Form 1099-S (proceeds from real estate transactions)
 - Form 1099-K (merchant card and third party network transactions)
 - Form 1098 (home mortgage interest), 1098-E (student loan interest), 1098-T (tuition)
 - Form 1099-C (canceled debt)
 - Form 1099-A (acquisition or abandonment of secured property)
- Use Form W-9 only if you are a U.S. person (including a resident alien), to provide your correct TIN.
- If you do not return Form W-9 to the requester with a TIN, you might be subject to backup withholding. See What is backup withholding, later.*



OBTAINING SERVICE

Return this vehicle to any IC Bus Dealer authorized to service this model vehicle and engine.

DISCLAIMER

NO WARRANTIES ARE GIVEN BEYOND THOSE DESCRIBED HEREIN. THIS WARRANTY IS IN LIEU OF ALL OTHER WARRANTIES, EXPRESSED OR IMPLIED. THE COMPANY SPECIFICALLY DISCLAIMS WARRANTIES OF MERCHANTABILITY AND FITNESS FOR A PARTICULAR PURPOSE, ALL OTHER REPRESENTATIONS TO THE USER/PURCHASER, AND ALL OTHER OBLIGATIONS OR LIABILITIES. THE COMPANY FURTHER EXCLUDES LIABILITY FOR INCIDENTAL AND CONSEQUENTIAL DAMAGES, ON THE PART OF THE COMPANY OR SELLER. No person is authorized to give any other warranties or to assume any liabilities on the Company's behalf unless made or assumed in writing by the Company; and no other person is authorized to give any warranties or to assume any liabilities on the seller's behalf unless made or assumed in writing by the seller.

Remedies Under State or Provincial Law: Any suit for breach of this Limited Warranty must be initiated within one year after breach. Some States and Provinces do not allow the exclusion or limitation of incidental or consequential damages, so the above limitation or exclusion may not apply to the owner. This warranty gives the owner specific legal rights, and he may also have other legal rights which may vary by state or province.

RECORD OF OWNERSHIP

Upon receipt of new vehicle by original owner, complete the following:
I have read this Warranty Brochure and fully understand the warranty coverage, and the limitations and exclusions. I acknowledge that I have received a copy of the Owner's Limited Warranty and I accept the terms described herein.

_____	_____
Customer Signature	Date
_____	_____
Owner's Address	City State/Prov Postal Code
_____	_____
Bus Model	Vehicle Identification Number
_____	_____
Engine Number	Engine Serial Number
_____	_____
Date Delivered to User (DTU)	Odometer Reading at Delivery

IMPORTANT: The information contained in this Warranty Policy explains the coverage provided on your new IC Bus™ brand vehicle. This policy should be kept in the vehicle for presentation to the Dealer when you request warranty services.
Any provisions of this Limited Warranty that are prohibited or not enforceable in any jurisdiction shall be, as to such jurisdiction, ineffective to the extent of such prohibition or non-enforceability without invalidating the remaining provisions hereof, and any such prohibition or non-enforceability in any jurisdiction shall not invalidate or render non-enforceable any such provisions in any other jurisdiction.
All claims under this Limited Warranty must be submitted in writing to an authorized IC Bus dealer within the warranty period as stated herein. If you have questions regarding this Limited Warranty, contact IC Bus, LLC dealer. To locate nearest dealer, visit the IC Bus website www.ICBus.com.

EFFECTIVE WITH VEHICLES BUILT MARCH 01, 2017 OR LATER

LIMITED WARRANTY FOR SCHOOL BUS MODELS
CE Series (PB105), RE Series (PB305), BE Series (PB405)

IC Bus, LLC warrants to the original purchaser (the "Purchaser") that IC Bus, LLC brand buses and component parts thereof are, at the time of purchase, free from defects in material and workmanship and will remain free from such defects under normal use after delivery to the Purchaser as provided herein. Warranty shall begin at the time of delivery unless otherwise approved by IC Bus, LLC. The delivery limitations as set forth herein shall run from the date of delivery to the Purchaser in the United States of America and Canada. The remedy available under this Limited Warranty is non-cumulative in nature and is limited to repair or replacement at IC Bus, LLC option of the bus or component parts thereof that are returned to locations approved by IC Bus, LLC transportation charges prepaid, and which IC Bus, LLC examination disclosed to its satisfaction to be defective. IC Bus, LLC, at its option, will repair or replace any part of this vehicle which proves defective in material and/or workmanship in normal use and service, with new or ReNEWed parts. Exceptions are listed below under *What Is Not Covered*.

This warranty is automatically transferred to subsequent owners at no charge. Visit your local IC Bus Dealer for name and address change information.

COMPONENT COVERAGE

The components described below are given additional warranty coverage of variable time periods and distance traveled limitations, as shown in the *Warranty Coverage Schedule*.

1. Frame Rails and Crossmembers
2. Body/Cowl Structure
 - Body Structure defined as the steel body frame (which includes the roof, metal floor, sides and front and rear sections only).
 - As to items not considered Body Structure include but are not limited to the following: doors, corner moldings, inner ABS panels, interior wall, plywood, floor covering, windows, and trim moldings.
3. The Body/Cowl is warranted against perforation due to corrosion, except for perforation caused by industrial chemicals and/or corrosion caused by use in a corrosive industrial environment.
4. Navistar Diesel Engine Coverage Includes: Navistar Diesel Engine block, cylinder heads, internally lubricated components fuel pump, high pressure pump, turbocharger, water pump, air compressor, injectors/nozzles; electronic engine modules, engine relays, engine sensors and regulators required for electronic engine operation, and certain aftertreatment components. Excluding: attaching accessories (e.g., fan clutch, alternator, starter, etc.), and externally mounted electrical and filtration systems.
5. Power Solutions International 8.8L Propane and Gas Engine Coverage Includes: Engine block, cylinder heads, internally lubricated components, water pump, air compressor, injectors/nozzles, fuel system components; electronic engine modules, engine relays, engine sensors and regulators required for electronic engine operation, exhaust catalyst. Excluding: attaching accessories (e.g., fan clutch, alternator, starter, etc.)
6. Spicer front & rear axles and propeller shaft, when used with Allison transmission; excluding brakes, wheel ends axle shafts, controls & attachments.

THE PROVISIONS HEREOF CONSTITUTE THE EXCLUSIVE AND COMPLETE WARRANTY BY IC BUS, LLC ON IC BUS™ BRAND BUSES AND COMPONENT PARTS THEREOF MANUFACTURED BY IT, OR APPROVED BUS BODY CONTRACT MANUFACTURERS AND IS IN LIEU OF ALL OTHER OBLIGATIONS OR LIABILITIES OF IC BUS, LLC WHETHER EXPRESS OR IMPLIED.

Note: The customer has 365 days and up to a maximum of 100,000 miles (160,000 km) from DTU (delivery to end user) to purchase an extended warranty on the unit. For extended warranty purchases between 181 and 365 days from DTU and <100,000 miles (160,000 km) an additional fee will be assessed. See your local IC Bus dealer for details.



Items Covered	Months	Miles/Km (000)
BASIC VEHICLE COVERAGE		
Basic Vehicle Warranty	12	Unlimited
Towing (Chassis related issues)	3	Unlimited
Towing (Vehicles with Navistar built engine failures only)	24	Unlimited
Towing (Vehicles with Power Solutions International, Inc. 8.8L Propane engine failures only)	60	Unlimited
Towing (Vehicles with Power Solutions International, Inc. 8.8L Gasoline engine failures only)	60	Unlimited
COMPONENTS		
Frame Rails and Crossmembers	60	Unlimited
Body/Cowl Structure (Roof, Metal Floor, Sides and Front and Rear Sections)	60	Unlimited
Body/Cowl Perforation Corrosion	60	Unlimited
Bumper Corrosion and Paint Delamination	36	Unlimited
Body/Cowl/Hood Paint Delamination	60	Unlimited
Brightwork, Chassis Paint and Corrosion	6	Unlimited
IC Bus, LLC Factory Installed Air-Conditioning (IC Air)	30	Unlimited
SEATS***IC Bus manufactured Seats Only		
Foam	48	50/80
Upholstery	24	24/40
Frame and Barriers	60	Unlimited
ENGINE*		
Power Solutions International, Inc. 8.8L Propane Engine	60	Unlimited
Power Solutions International, Inc. 8.8L Gasoline Engine	60	Unlimited
DRIVETRAIN**		
Eaton Precision Transmission	12	Unlimited
Spicer - 3 Part Dana Drivetrain (Front & Rear Axles, Propeller Shaft, When Used With Allison Transmission Only)	48	50/80
Meritor Axles	48	75/120

WHAT IS NOT COVERED

AFTER THE FIRST 90 DAYS FROM DELIVERY TO USER (DTU):

- Correction of loose fasteners, squeaks, rattles and unusual noises.
- Towing (vehicles with non-engine failures only)
- Adjustments (e.g., headlights, brake/clutch adjustments, steering system adjustments, coolant levels, doors).

COMPONENTS / ITEMS:

- Warranted by their respective manufacturers (e.g., non Navistar brand engines, tires & tubes, Allison Transmissions, Hybrid electric, lubricants, etc.)
- Bodies, equipment and accessories installed by other than authorized IC Bus employees at IC Bus manufacturing plants.
- Front and rear axle alignment.
- Front & Rear axle coverage excludes brakes, wheel ends, axle shafts, controls & attachments.

REPAIRS:

- Maintenance-related items/repairs or those as a result of normal wear and tear, including tune-ups, brake/clutch lining, windshield wiper blades, tire balancing, lubrication and other similar procedures/parts required to keep vehicle in good working condition.
- To any part of the vehicle subjected to misuse, negligence, improper maintenance, improper operation, or which is the result of an accident.
- Fade, runs, mismatch or damage to paint, trim items, upholstery, chrome, polished surfaces, etc., resulting from environmental causes, improper polishes, cleaners or washing solutions, or chemical and industrial fallout.
- In which power train, propeller shaft and suspension sales guidelines (specifications) are not strictly adhered to by all owners and operators of this vehicle.

OTHER:

- Vehicles sold and/or operated outside the United States and Canada.
- Vehicles/components that have had unauthorized alterations or modifications.
- Vehicles on which the odometer reading has been altered.
- Loss of time or use of the vehicle, loss of profits, inconvenience, or other consequential or incidental damages or expenses.
- Replacement of defective parts with parts other than those provided by IC Bus, LLC.

This warranty does not apply, or include coverage for defects attributable to the following:

- (a) Damage resulting from: (i) misuse, abuse, accident, neglect, negligence, vandalism, fire, riot, war, or Acts of God;
- (b) (ii) Structural or other modifications or alteration without prior express written authorization by IC Bus, LLC; (iii) Repair or attempted repair by unauthorized persons; (iv) Replacement of original components with substitutes without prior express written authorization by IC Bus, LLC; (v) Failure to perform routine preventative maintenance as customarily accepted within the industry or failure to provide proof of such preventative maintenance having been performed; (vi) Exposure to corrosives, contaminants, chemicals, salt, irradiation or atmospheric or environmental conditions; (vii) Usage or loading in excess of recommended capacities or in non-standard applications, including off-road.
- (c) Fading or discoloration of paint, lettering or decals.
- (d) Effects of aftermarket installation and aftermarket parts installed by the dealer or customer.

*Emission Coverage: Refer to engine operator's manual for emission coverage.

**Drivetrain:

- Allison Transmissions products or Transynd lubricants and fluids are not covered under this warranty. For warranty information see: www.allisontransmission.com/publications/
- For specific Eaton/Fuller Warranty coverage, see supplier information: www.roadrangerwarranty.com
- For extended component warranty: www.roadranger.com/Roadranger/warranty/Extended_Warranty/index.htm

***For non IC Bus Manufactured seats, contact the seat supplier for their warranty coverage. For Enova charge sustaining and charge depleting standard warranty to: <http://enovasystems.com/customer-support.html>

*1/24/2019 removed MaxxFace Engines from coverage as Buses built post March,1,2017 no longer offered this engine.



Revised 4/1/2019

Telematics Data Disclosure

Your Navistar vehicle may include an activated telematics subscription service. By accepting this Limited Warranty you consent to our collection and use of data from your vehicle as set forth at www.oncommandconnection.com on behalf of yourself and any vehicle operators and passengers. Navistar, Inc. or its affiliates will collect and send diagnostic and system data from your vehicle and use it for various purposes as further set forth in our Privacy Policy, posted at www.oncommandconnection.com, such as improving the uptime for your vehicle, improving our vehicles in the future, and reducing warranty events. If you choose not to allow Navistar to access your data, you may suspend your subscription at www.InternationalTrucks.com/Opt-Out

**RE/CE BUS EXTENDED VEHICLE COVERAGE
INCLUDING BUS BODY**

This **Extended Vehicle Coverage Including Bus Body option(s)** provides coverage for time or distance traveled from new vehicle delivery date, whichever expiration occurs first.

During the period selected, Navistar, Inc. will repair or replace any of the covered components as defined below which proven defective in material and/or workmanship in normal use, with new or ReNEWed parts. Exceptions are listed herein under *What is Not Covered*.

GROUP 01 - FRAME AND BUMPER

- | | | |
|---------------------------|--------------------------------|--------------------------------|
| 067 - Carrier, Tire | 306 - Outtrigger, Bus Platform | 581 - Bumper Frame |
| 071 - Bumper | Mounting | 660 - Rail, Frame Side |
| 211 - Bracket or Mounting | 307 - Crossmember | 739 - Reinforcement or Gussets |
| | 309 - Crossmember, Engine | |

GROUP 02 - FRONT AXLE

- | | | |
|--------------------------|-------------------------|--------------------------|
| 016 - Arm, Steering | 353 - Fitting/Zerk | 667 - King Pin & Bushing |
| 032 - I-Beam, Front Axle | 535 - Knuckle, Steering | 799 - Seal, King Pin |

GROUP 03 - SUSPENSION

- | | | |
|--|--|------------------------------------|
| 062 - Equalizer / Rocker Arm and Bushing | 264 - Control (Air Suspension Only) | 468 - Spring Leaf Assembly |
| 066 - Torque Arm & Bushing Assembly | 341 - Bracket, Shock Absorber Mounting | 584 - Bracket Assembly, Spring |
| 074 - Walking Beam & Bushing Assembly | 406 - Bolt, Center | 646 - Shackles, Pins & Bushing |
| 203 - Air Bag Assembly | 437 - Suspension Air Control Manifold Assembly | 711 - Crossmember, Rear Suspension |
| | 438 - Suspension, ECM | 769 - Sway Bar Assembly |
| | | 804 - Stop, Axle |

GROUP 04 - BRAKES

- | | | |
|--|---|--|
| 003 - Tank, Air, Vacuum | 429 - Cable/Linkage, Parking Brake | 811 - Relay/Magnetic Switch |
| 005 - Knob | 461 - Linkage / Cam / Camshaft, Wheel Brake Actuating | 812 - Valve, Modulator |
| 007 - Pumps | 462 - Linkage/Pedal/Spring Brake Actuating | 816 - Sender, Wheel |
| 009 - Accumulators | 511 - Power Assist Unit | 826 - Caliper |
| 010 - Hydraulic Power Brake (HPB) Unit | 617 - Backing Plate/Anchor/Dust Shield | 840 - Caliper Bracket |
| 012 - Solenoid Valve | 634 - Pump, Back-Up (Less Motor) | 842 - Switch, Flow |
| 013 - Adjuster, Slack | 636 - Motor, Back-Up | 846 - Switch, Back-Up Motor |
| 020 - Cylinder, Self Actuate Hydraulic Release | 643 - End Cover, Unloader Valve Air Dryer | 847 - Switch, Pressure Differential |
| 036 - Adjuster Assembly, Automatic | 662 - Spring, Brake Shoe Return | 848 - Module, Monitor |
| 105 - Bracket, Brake Chamber | 747 - Spring Applied Air Release (Saar) Canister | 851 - Valve, Spring Brake Control |
| 231 - Chamber | 751 - Sensor, Steering Angle | 852 - Brake Assembly, Drive Line |
| 232 - Diaphragm, Chamber | 753 - Sender, Stability Control | 909 - Harness, Cab |
| 255 - Cylinder, Master | 801 - Control Unit, Electronic ECU | 913 - Valve, Foot Control or Pedal |
| 390 - Reservoir | | 920 - Valve, Hand Control |
| 392 - Switch, Fluid Level | | 923 - Harness, Front End (Wires/Connectors/Term) |
| 397 - Governor and Mounting, Air | | 932 - Valve, Front Wheel Limiting & Mounting |

940 - Harness, PDM
Distribution

GROUP 05 - STEERING

018 - Arm, Pitman
069 - Link, Drag
164 - Column Assy. &
Mounting, Steering
167 - Wheel Mechanism, Tilt
Steering
206 - Couplings/U-Joint,
Steering Shaft

GROUP 06 - PROP SHAFT

101 - Bearing
165 - Mounting, Bearing

GROUP 07 - EXHAUST

107 - Assembly, Basic
143 - Bracket/Support,
Mounting
426 - Guard / Heat Shield

GROUP 08 - ELECTRICAL

005 - Knob
018 - Alternator Assembly
038 - Multiplex Signal Module
(MSM)
041 - Telematics Control
Module (TCM)
049 - Switch, SOS
059 - Regulator, Voltage
063 - Solenoid Base, Pneumatic
Accessory
065 - Solenoid Unit, Pneumatic
Accessory
073 - Amplifier, Pyrometer
074 - Gauge, Voltmeter
076 - Gauge, Fuel Level
088 - Gauge, Oil Pressure
(Electrical)
097 - Gauge, Coolant
Temperature (Electrical)
099 - Gauge, Ammeter
109 - Gauge, Engine Oil
Temperature
110 - Gauge, Pyrometer
111 - Gauge, Rear Axle Oil
Temperature
116 - Gauge, Speedometer
(Electrical)
117 - Gauge, Tachometer
(Electrical)
118 - Gauge, Transmission Oil
Temperature
124 - Sender, Fuel Level

944 - Valve, Quick Release
955 - Pully

252 - Wheel, Steering
311 - Gear Assembly, Steering
314 - Gasket, Power Steering
Pump Mounting
316 - Wheel Mechanism,
Telescoping Steering
370 - Bracket/Mounting,
Steering Gear

391 - Joint, Universal
475 - Boot / Clamp, Slip Joint

533 - Tail Pipe, Exhaust Gas
Cooler
551 - Pipe, Crossover
576 - Pipe & Flange, Exhaust

127 - Tachometer/Trip Recorder
(Elec Driven)
155 - Sender, Pyrometer
156 - Sender, Rear Axle Oil
Temperature
159 - Sender, Transmission Oil
Temperature
202 - Motor, Starter
217 - Solenoid, Starter Motor
221 - Bezel/Cover Plate
223 - Circuit Board
224 - Switch, Speedometer /
Tachometer Dip
(Reprogramming Only)
225 - Panel, Circuit
Breaker/Relay/Fuse
226 - Mounting, Circuit
Breaker/Relay/Fuse Panel
251 - Harness, Coiled Ribbon
(Clock Spring)
266 - Switch, Clutch
269 - Module, Coolant Probe
270 - Probe, Coolant Level
284 - Antenna and Lead-In
347 - Mounting
372 - Module, Pyrometer
373 - Module, Ammeter
374 - Circuit Housing,
Speedometer / Tachometer
375 - Sender, Air Pressure
388 - Lamp Assembly

990 - Wiring

555 - Cylinder Assembly &
Valves
653 - Cooler Assembly, Oil
701 - Pump Assembly
757 - Reservoir Assembly
818 - Valve, Control
955 - Pulley

478 - Shaft
703 - Yoke/Spline

615 - Pipe/Stack, Tail
775 - Cap, Stack
824 - Pipe, Flex

401 - Clean Power Cable
(Battery To Cab)
404 - Flasher
405 - Beeper, Hydraulic Brake
Warning
407 - Alarm, High Water
Temp/Low Oil Press.
408 - Beeper, Low Air Pressure
418 - Regulator & Motor
Assembly
424 - Hourmeter
430 - Odometer
487 - Horn Assembly
499 - Contact Ring/Button, Horn
508 - Monitor, Driver Display
Unit
510 - Sensor, Radar Side/Front
511 - Camera, Forward Looking
512 - Display, Side Sensor
514 - Sensor, Turn Assembly
516 - Magnet, Turn Sensor
Assembly
518 - Harness, Side Sensor
585 - Automatic Headlight
Sensor
586 - Antenna, Tire Pressure
Monitor
587 - Brake Stroke Chamber
W/Sensor
588 - Display, Vehicle
Information

589 - Fuel Filter Restriction
Globe W/Sensor
595 - Module/Controller, Tire
Pressure Monitor
596 - Module, Vehicle Sensor
598 - Batteries, Jumper Cable
599 - Sensor, Brake Pad Wear
601 - Wheel Module, Tire
Pressure Monitor
607 - Switch, Air Horn
608 - Clock
609 - Switch, Cruise On/Off
618 - Switch, Cruise Set/Reset
620 - Switch, Engine Brake
On/Off
621 - Switch, Headlight
Interrupt
623 - Switch, Marker Interrupt
624 - Switch, Radio
628 - Switch, Transmission
Mode
629 - Switch, Transmission Shift
637 - Alarm, Back-Up

GROUP 09 - COOLING

012 - Solenoid Valves
022 - Core
026 - Shutter Assembly
047 - Hose/Pipe, Radiator
064 - Tank & Neck, Radiator
083 - Shroud Clamp
085 - Shroud Mounting Bracket
091 - Shroud, Engine Mounted
108 - Cylinder Assembly,
Actuating
123 - Mounting, Radiator
136 - Motor
142 - Rod Assembly, Control

GROUP 10 - INSTRUMENTS

053 - Head Assembly

GROUP 11 - CLUTCH

059 - Bearing and Sleeve
Assembly, Release
101 - Cylinder, Master
133 - Cylinder, Slave

GROUP 12 - ENGINE

222 - Solenoid
740 - Blade Assembly, Fan
744 - Fan Drive, Viscous
746 - Fan Drive, On/Off
748 - Control, Fan Clutch
750 - Pulley, Fan
802 - Sart Module

705 - Solenoid, Air
718 - Solenoid
743 - Clean Power Cable (Batt
to Engine Connect
745 - Daytime Running Light
Switch
758 - Central Processing Unit
(CPU)
783 - Compass, Electronic
784 - Thermometer, Electronic
797 - Clean Power Cable (Batt
to Transmission)
811 - Relay/Magnetic Switch
815 - Switch, Key/Ignition
821 - Switch, Push Button
Starter
828 - Switch, Dimmer
835 - Switch, Back-Up Light
840 - Switch, Neutral Start
848 - Module Monitor
850 - Switch, Low Oil Pressure
854 - Controller, Esc
863 - Switch, Stoplight (Air)

176 - Shroud
197 - Shutterstat
210 - Glass, Sight
211 - Tank & Mounting, Surge
222 - Solenoid
240 - Motor / Pump
427 - Bottle and Hose, Coolant
Recovery
504 - Fan Module
616 - Cooler, In Tank Oil
701 - Pump Assembly
740 - Blade Assembly, Fan
755 - Electronic Fan Controller

292 - Fork and Cross Shaft,
Clutch Release
349 - Lever Assembly, Relay
403 - External Linkage

811 - Relay/Magnetic Switch
814 - Pedal Assembly,
Accelerator
828 - Front Mount/Bolt
836 - Rear Mount/Bolt
865 - Switch, Temperature

864 - Switch, Stoplight
(Hydraulic)
865 - Switch, High Water
Temperature
870 - Switch, Low Air Pressure
871 - Switch, Low Coolant
Level
872 - Switch, Parking Brake
884 - Switch, Headlight
885 - Switch, Marker/Interrupt
886 - Switch, Turn Signal
887 - Programming
907 - Actuator, Switch Pack
908 - Switch Pack (Base)
909 - Harness, Cab Wires
Conn's & Terminals
923 - Harness, Front End
(Wires, Connectors And
940 - Harness, PDM
Distribution
955 - Pulley
996 - Monitor, Battery Run
Down Protection

756 - Hydraulic Fluid Reservoir
767 - Oil Cooler (Oil-To-Air)
811 - Relay/Magnetic Switch
852 - Pipe, Charge Air Cooler
865 - Switch, Temperature
909 - Harness, Cab
(Wires/Connectors/Term)
925 - Charge Air Cooler,
Chassis Mounted
940 - Harness, PDM
Distribution

440 - Self Adjusting Mechanism
462 - Pedal
639 - Intermediate Plat
862 - Plate Assembly, Pressure

905 - Bracket, Air Compressor
Mtg.
909 - Harness, Cab
(Wires/Connectors/Term)
911 - Bracket, Alternator Mtg.
914 - Bracket, Refrigerant
Compressor Mounting

919 - Bracket, Power Steering
Pump Mounting
930 - Coupling, Accessory
Drive

GROUP 13 - TRANSMISSION

114 - Case
125 - Flange, Companion
138 - Block, Resistor
139 - Housing, Bell
191 - Retainer, Bearing
313 - Detent Poppet Ball &
Spring

GROUP 14 - REAR AXLE

013 - Adjuster, Slack
016 - Arm, Steering
068 - Spring, Lift
135 - Flange/Yoke, Comp
147 - Carrier
170 - Housing, Axle
203 - Air Bag Assembly
216 - Stud
231 - Chamber
265 - Control (Air Suspension
Control)
323 - Hanger and Crossmember
Assembly

GROUP 15 - FUEL SYSTEM

011 - Cap/Scoop, Air Inlet
014 - Box/Water Separator, Air
Inlet
026 - Pipe, Air Inlet
029 - Control System, Air Inlet
Temperature
142 - Pre-Heater Element
143 - Valve, Drain
144 - Valve, Check
145 - Cap, Vent

GROUP 16- CAB

006 - Stop, Hood
018 - Bezel, Head or Tail Lamp
027 - Step, Cab
053 - Cable, Hood
071 - Channel, Glass Run
078 - Remote Control/Cable,
Door
086 - Crossmember, Cab
Mounting
102 - Cab Tilt Lock Mechanism
103 - Cab Tilt Hinge
Mechanism
104 - Cowl/Firewall/SC or FC
Platform

938 - Gear, Power Steering
Pump Driver
946 - Tensioner, Belt
955 - Pulley/Idler/Bearing

616 - Cooler, Oil (Oil-To-Air)
677 - Line, Oil Cooler
785 - Linkage/Cable, Remote
Shift Control
825 - Switch, On/Off
839 - Switch, Brake
866 - Mounting

357 - Bearings, Internal (Axle
Carrier)
376 - Gears, Bushings & Cross,
Differential
395 - Differential, Limited Slip
424 - Bolt, Ring Gear
441 - Wheel End Gearboxes
448 - Gears, Helical
472 - Gears, Planetary
496 - Gears, Ring & Pinion
590 - Shaft, Helical Drive Gear
606 - Clutch, Sliding
619 - Control, Air Shift

146 - Pump, Primer
147 - Collar
148 - Body
177 - Filler Neck/Cap & Gasket
196 - Sensor, Water in Fuel
216 - Bracket, Stack Mounting
263 - Air Intake Grill
479 - Finish (Metal)
500 - Bracket & Bolts,
Mounting

121 - Suspension, Sleeper Bunk
122 - Cylinder, Lift
123 - Latch Assembly
129 - Cabinets
130 - Door
131 - Window, Sleeper
135 - Cylinder, Lift
139 - Door Assembly, Radiator
Access
146 - Shade, Sun
248 - Grille Assembly
264 - Handle, Grab
265 - Handle, Hood
282 - Hinge

909 - Harness, Cab (Wires,
Connectors & Term)
940 - Harness, PDM
Distribution

630 - Cylinder, Air Shift
654 - Fork, Shift
679 - Motor, Air Shift
707 - Bearing/Ret, P.D.
713 - Pump, Oil
719 - Case, P.D. Diff.
730 - Gears/Bushing & Cross
Power Divider
747 - Tank, Air Or Vacuum
969 - Knuckle, Steerable
970 - King Pin, Knuckle

637 - Tank Body
787 - Tube, Fuel Outlet
857 - Indicator, Air Restriction
890 - Transfer Pump, Electric
(Tank to Tank)
892 - Valve/Control, Fuel Tank
909 - Harness, Cab Wires
Conn's & Terminals
976 - Vent, Air
988 - Guard, Crash

291 - Hinge, Hood/Engine
Access Door Hatch
295 - Hood Guides
300 - Bunk Occupant Restraint
Strap/Tent
301 - Cowl Tray
309 - Hood
329 - Insulation
330 - Shield, Sound
336 - Insulation, Engine
Compartment
345 - Latch & Exterior Handle
362 - Latch, Hood

368 - Latch, Doghouse
 Panel/Engine
 398 - Map Pocket, Passenger
 Door
 409 - Air Intake Baffle/Water
 Sep. Baffle
 421 - Mirror, Spot
 423 - Mirror, Exterior (Basic)
 433 - Mirror, Interior
 459 - Mounting, Front Cab
 463 - Mounting, Intermediate
 Body
 468 - Mounting
 546 - Panel, Back
 555 - Doghouse Panel/Engine
 Cover
 567 - Panel, Floor
 568 - Panel, Halo
 569 - Panel, Engine Surround
 584 - Panel, Instrument
 611 - Panel, Splash
 619 - Panel / Skin
 625 - Rivet/Fastener
 627 - Weld

637 - Structure
 666 - Regulator & Handle,
 Window
 675 - Arm Rest
 684 - Roof
 721 - Spring/Shock Absorber &
 Mounting, Cab
 739 - Stop Assembly, Door
 748 - Sub-Frame
 799 - Console
 802 - Manifest Box/Door Pouch
 804 - Trim, Interior
 805 - Trim, Bunk
 806 - Mirror, Interior
 807 - Under Bunk Lift Assist
 Shock
 811 - Relay/Magnetic Switch
 (Electric Mirror)
 825 - Switch, Electric Mirror
 833 - Valve, Control
 844 - Ventilator
 855 - Visor, Sun
 877 - Vent Window & Seal
 896 - Trim, Hood

909 - Harness, Cab
 (Wires/Connectors/Term)
 926 - Shor Power Connection
 928 - Door, Hood / Engine
 Access
 929 - Hinge / Bracket, Front
 Hood Mounting
 934 - Reinforcement, Hood
 935 - Torsion Bar, Hood Assist
 936 - Latch, Engine Access
 Door
 958 - Bracket, Sun Shade
 Mounting
 972 - Panel, Rear Trim
 973 - Panel, Door Trim - Driver
 Side
 974 - Panel, Door Trim -
 Passenger Side
 975 - Holder, Cup
 991 - Motor, Mirror
 992 - Heater, Mirror
 994 - Bracket, Mirror

GROUP 17 - WHEELS

031 - Disc Wheel
 087 - Hub (Disc Wheel)
 108 - Rim (Demountable)
 386 - Spoke Wheel

GROUP 18 – SCR AFTERTREATMENT

045 - Hose, Pump to Tank
 Supply / Suction
 046 - Hose, Pump to Tank
 Return
 047 - Hose, Pump to Doser /
 Injector
 124 - Sensor Assembly, Def
 Tank
 177 - Cap, Filler Tank
 180 - Cover, Supply Module
 181 - Heater, Tank
 350 - Hose, Tee to Doser
 351 - Hose, Doser To Tee
 500 - Bracket/Strap, Def Tank
 501 - Bracket, Supply Module
 Pump
 502 - Bracket, ACM
 565 - Wiring, (Sensor)
 637 - Tank, Diesel Exhaust
 Fluid
 787 - Pickup, Tank
 793 - Tank Def, Coolant Flow
 Valve
 801 - Module, PDM
 906 - Wiring, ACM
 907 - Wiring, Supply Module
 908 - Wiring, Heated Line
 909 - Wiring, Head Unit

GROUP 19 - ACCESSORIES

001 - Fan, Defroster
 015 - Clutch, Compressor
 028 - Compressor/Reciprocating
 029 - Compressor/Rotary
 043 - Condenser
 045 - Linkage, Wiper
 070 - Switch, Radiator
 Fan/Shutter Override
 076 - Core (Heater)
 094 - Evaporator
 100 - Meter Assembly, Engine
 105 - Wheel, Blower
 138 - Block, Resistor
 149 - Accumulator/Dryer
 182 - Valve, Expansion
 183 - Valve, Rear Expansion
 187 - Ducting, Air
 Cond/Heater/Defroster
 197 - Horn Assembly
 214 - Valve, Control
 251 - Harness, Coiled Ribbon
 (Clock Spring)
 310 - A/C O Ring
 317 - Schrader Valve, Low Side
 318 - Schrader Valve, High Side
 325 - Solenoid, Pneumatic
 327 - Switch, Air Horns
 331 - Electric Air Compressor,
 Seat
 343 - Shock, Seat
 344 - Adjuster Assembly, Seat
 351 - Frame, Seat
 353 - Fitting
 354 - Control, Air Seat
 355 - Mounting/Housing (Main
 Case)
 363 - Bag, Air
 381 - Retractor, Seat Belt
 386 - Belt, Seat
 411 - Plate, Fifth Wheel
 417 - Control, Fifth Wheel

435 - Heater Assembly, Engine
 436 - Socket, Engine Heater
 443 - Back-Up Camera
 472 - Reservoir
 506 - Lock Cylinder, Fifth Wheel
 632 - HVAC Hose, Under Cab to Rear
 675 - Rest, Arm
 708 - Module, Blower Speed LPM
 709 - Module, HVAC Control
 733 - Actuator, Motor/Door - Blend Air

734 - Actuator, Motor / Door – Fresh Air
 735 - Actuator, Motor/Door - Air Distribution
 763 - Sensor, Refrigerant Pressure
 764 - Thermistor, Inlet
 765 - Thermistor, Outlet
 807 - Module, Vehicle Personality (VPM)
 825 - Switch
 826 - Switch, Bunk-On/Off
 827 – Switch Bunk-Temperature Control

830 - Switch, Intermittent
 837 - Switch, Clutch
 838 - Switch, Set-Resume
 849 - Module, Diagnostic - APADS
 880 - Switch, Pressure-Low
 881 - Switch, Pressure-High
 882 - Switch, Thermostatic
 885 - Freeze Sensor
 909 - Harness, Cab (Wires, Connectors and Terminals)
 923 - Harness, Front End (Wires/Connectors/Term)

GROUP 22 - GENESIS BODY - COMP

001 - Fan, Defroster
 040 - Bows
 042 - Cowl, Front
 044 - Frame, Rear
 046 - Rails, Drip
 048 - Rails, Seat
 050 - Spacers, Bow
 052 - Steps
 055 - Bumper, Front
 056 - Bumper, Rear
 060 - Header, Entrance Door
 061 - Frame, Entrance Door
 062 - Drivers Seat Sub-Frame (K Frame)
 063 - Frame, Side Emergency Door
 064 - Frame, Rear Emergency Door
 065 - Frame, Lift Door
 066 - Frame, Body to Cab Floor
 067 - Frame, Body to Cab Roof
 068 - Frame, Davenport
 080 - Bars, Light
 082 - Bumpers, Header
 084 - Caps, Inside
 086 - Insulation
 088 - Lining, Lower
 090 - Lining, Overhead
 092 - Racks, Luggage
 094 - Rails Grab
 096 - Rails, Shoulder
 098 - Rails, Standee
 100 - Reduction, Noise
 120 – Bracket, License Plate
 122 - Caps, Outside
 124 - Caps, Post
 126 - Door, Fuel
 128 - Handles, Access
 129 - Front Fiberglass Panel

130 - Panels, Rear Inside Window
 131 - Front Sheet Metal
 134 - Rails, Rub
 136 - Rails, Snow
 138 - Sheets, Side
 140 - Skins, Rear Outside
 141 - Hatch, Roof
 142 - Skirts
 146 - Roof Panels(Topping)
 148 - Door, Engine
 151 - Door, W/S Wiper
 152 - Grille
 200 - Electrical Access Compartment
 204 - Battery, Compartment
 208 - Spare Tire Compartment
 212 - Luggage Compartment
 214 - Safety Compartment
 216 - Destination Sign Compartment
 218 - Tool Compartment
 239 - Controls Air
 240 - Boxes, Buzzer
 241 - Controls Electric
 243 - Controls, Manual
 244 - Devices, Hold Bac
 246 - Doors, Entrance
 248 – Doors, Lift – Single / Double
 250 - Doors, Emer. Rear
 252 - Doors, Emer. Side
 254 - Handles, Door
 256 - Hinges
 258 - Locks, Door
 262 - Vandalocks
 275 - Light, Step
 281 - Electric Panel
 283 - Fuse Panel
 284 - Horns

294 - Speakers
 296 - Switches
 297 - Radio
 298 - Antenna
 322 - Panels, Floor
 326 - Sills, Floor
 330 - Tiedown Bolts, Plates, J-Bolts, U-Bolts
 332 – Wheel pocket Assy.
 339 - Transition Panel / Cowl Filler Panel
 340 - Doors, Engine Service
 350 - Cross View Mirror
 360 - Cover, Wheel-Pocket
 364 - Moulding, Cove
 366 - Treads, Step
 369 - Wig-Wag
 389 - Child Check Mate
 402 - Window, Driver's
 410 - Window, Emergency Exit
 416 - Window, Split Sash
 423 - Thermistor, Inlet
 425 - Switch, Radiator Fan / Shutter Override
 426 - Window, Split Storm
 427 - Switch, Pressure - Low
 429 - Clutch, Compressor
 430 - A/C Compressor, Rotary
 431 - Ducting, Air Conditioner
 432 - Wheel, Blower
 433 - Hose, A/C
 434 - O-Ring, A/C
 435 - Schrader Valve, Low Side
 436 - Sensor, Refrigerant Pressure
 437 - Switch
 438 - Accumulator / Dryer
 439 - Switch, Pressure - High
 440 - Heater, Under Seat

441 - Harness, (Wires, Connectors, & Terminals)	471 - Harness, Power Distribution (On Flasher Plate)	544 - Red Light
442 - Heater, Rear	472 - Switch, Thermostatic	546 - Stop Light
444 - Covers/Trim, Hose	474 - Thermistor, Outlet	548 - Stop/Tail Light
445 - Control Cable	475 - Tube, Drain	550 - Strobe Light
446 - Driver's Heater	476 - Tube, Orifice	554 - Warning Light
447 - Core, Heater	478 - Motor	556 - Lift Door Light, Interior
449 - Motors, Heater	479 - A/C Electric Control Panel	558 - Lift Door Light, Exterior
450 - Stepwell Heater	480 - Panels, Modesty	560 - Cowl Mount Mirror
451 - Pump, Booster Heater	484 - Restraints, Lap	562 - Fender Mount Mirror / Rear View
453 - Condenser	488 - Stanchions	564 - Heated Mirror
454 - Fan, Condenser	493 - Harness, Left Hand Body	566 - Inside Rear View Mirror
455 - Evaporator	494 - Harness, Right Hand Body	568 - Spy Mirror
456 - Defroster Duct	495 - Harness, Flasher to Cowl	640 - Alarms, Backing
457 - Valve, Expansion	498 - Harness, Body Options External (Engine)	662 - Sign, Designation
459 - Fitting / Pipe (A/C)	499 - Microphone	682 - Crash Barrier Frame
460 - Harness, Front End	501 - Harness, Dash	684 - Belts, Seat
462 - Relay / Magnetic Switch	520 - Back-Up Light	692 - Passenger Seat Frame
463 - Schrader Valve, High Side	524 - Instrument Cluster Light	694 - Shields, Courtesy
464 - Harness, Flasher Plate	526 - Directional Light	697 - Flip Seat Frame
465 - Harness, LH Switch Panel	528 - Directional, Side Light Assembly	720 - Stop Arm
466 - Harness, Rh Switch Panel	534 - Fog Light	726 - Gates, Crossing
467 - Harness, Over Head Switch Panel	536 - Headlights	740 - Motor, Stop Arm
468 - Valve, Water (Dash Mounted A/C Heater Unit)	540 - License Plate Light, Assembly	742 - Motor, Stop Arm Module
469 - Harness, Front Cap	542 - Marker Light	762 - Static Vent
470 - Harness, Rear Cap		810 - Motor, Drive
		812 - Washer

WHAT IS NOT COVERED

Components / Items:

- Correction of loose fasteners, squeaks, rattles and unusual noises.
- Adjustments (e.g., headlights, brake/clutch adjustments, steering system adjustments, coolant levels).
- Items warranted by their respective manufacturers (e.g., non-Navistar brand engines, tires & tubes, Allison Transmissions, clutch, batteries, radios, lubricants, etc).
- Any part that is not a Navistar part number.
- Unauthorized parts other than Navistar service parts or ReNEWed® parts.
- Bodies, equipment and accessories installed by other than authorized Navistar employees at Navistar manufacturing plants.
- Front and rear axle alignment.
- Engine, Engine Electronics, Injectors, Turbocharger.
- Hybrid Electric Components (except Hybrid/Electric Drive Cooling).

Repairs:

- Maintenance-related items/ repairs or those as a result of normal wear and tear, including tune-ups, brake/clutch lining, clutch brake, windshield wiper blades, windshield wiper nozzles, gaskets, belts, seals, tire balancing, lubrication, batteries and other similar procedures/parts required to keep vehicle in good working condition. Such maintenance items or repairs include, but are not limited to oil changes, oil filters, air filters, desiccant cartridge, fuel filters, tire rotation, cleaning/polishing, engine tune-up, adding oils, tightening of air intake and coolant clamps, ash tray, cigarette lighter element, fire extinguishers, fluorescent ballast and tubes, fuses, gladhand and gladhand rubbers, trailer hoses, hose tenders, trailer electrical cables, light bulbs, mattress, mud flaps, mud flap mounting bracket.



- Repairs to any part of the vehicle subjected to misuse, negligence, improper maintenance, improper operation, or which is the result of an accident.
- Fades, runs, mismatch or damage to paint, trim items, upholstery, chrome, polished surfaces, etc., resulting from environmental causes, improper polishes, cleaners or washing solutions, or chemical and industrial fallout.
- No coverage will be granted if Power Train, Propshaft and Suspension sales guidelines (specifications) are not strictly adhered to by all owners and operators of this vehicle.
- Accidents, acts of nature or other events beyond control of Navistar.
- Any single repair requiring less than \$40.00 parts and labor to complete.

Other:

- Vehicles sold and/or operated outside the United States or Canada.
- Vehicles/components which have had unauthorized alterations or modifications.
- Vehicles on which the odometer reading has been altered.
- Incidental or consequential costs or expenses which the owner may incur as a result of a malfunction or failure covered by this warranty, such as vehicle damage, communication expenses, meals, lodging, overtime, loss of use of engine or vehicle (“downtime”), loss of time, inconvenience, cargo loss or damage, and other similar costs and expenses.
- Replacement of defective parts, which were, not authorized Navistar equipment when first installed.
- Towing, unless additionally purchased.

OBTAINING SERVICE

To obtain service under this Service Contract, return this vehicle to any Navistar truck dealer authorized to service this model vehicle and engine. To locate an authorized dealer near you, please call the Navistar Customer Service Center at 800-44-TRUCK (800-448-7825).

DISCLAIMER

NO WARRANTIES ARE GIVEN BEYOND THOSE DESCRIBED HEREIN. THIS WARRANTY IS IN LIEU OF ALL OTHER WARRANTIES, EXPRESSED OR IMPLIED. THE COMPANY SPECIFICALLY DISCLAIMS WARRANTIES OF MERCHANTABILITY AND FITNESS FOR A PARTICULAR PURPOSE, ALL OTHER REPRESENTATIONS TO THE USER/PURCHASER, AND ALL OTHER OBLIGATIONS OR LIABILITIES. THE COMPANY FURTHER EXCLUDES LIABILITY FOR INCIDENTAL AND CONSEQUENTIAL DAMAGES, ON THE PART OF THE COMPANY OR SELLER. No person is authorized to give any other warranties or to assume any liabilities on the company’s behalf unless made or assumed in writing by the Company; and no other person is authorized to give any warranties or to assume any liabilities on the seller’s behalf unless made or assumed in writing by the seller.

Remedies Under State or Provincial Law: Some States and Provinces do not allow the exclusion or limitation of incidental or consequential damages, so the above limitation or exclusion may not apply to the owner. This warranty gives the owner specific legal rights, and he may also have other legal rights which may vary by state or province.

Navistar, Inc., except in Canada where it is Navistar Canada, Inc.

TOW COVERAGE \$1,100 PER INCIDENT

This service contract for **Towing option(s)** provides coverage for 24 months or unlimited miles/kilometers traveled from new vehicle delivery date, whichever expiration occurs first.

During this period, Navistar, Inc. ("Navistar") will pay for a service call and/or towing to the nearest IC Bus, International[®] or Cummins dealer WITH A NAVISTAR OR CUMMINS WARRANTABLE AND MISSION-DISABLING UNSAFE OPERATING CONDITION FAILURE. Coverage of Cummins failure begins AFTER the expiration of the Cummins second year of standard tow coverage for school bus if an additional Cummins service contract is active in Navistar Service Portal. Maximum liability for Navistar, per incident, is \$1,100. Exceptions are listed herein under section *What is Not Covered*.

WHAT IS NOT COVERED**Repairs:**

- Towing in connection with a failure that is NOT warranted with Cummins or Navistar.
- Any expense over the \$1,100.00 maximum liability, per incident.

Other:

- Buses sold and/or operated outside the United States and Canada.
- Buses /components which have had unauthorized alterations or modifications.
- Buses on which the odometer reading has been altered.
- Loss of time or use of the bus, loss of profits, inconvenience, or other consequential or incidental damages or expenses.
- Incidental or consequential costs or expenses which the owner may incur as a result of a malfunction or failure covered by this warranty, such as vehicle damage, communication expenses, meals, lodging, overtime, loss of use of engine or vehicle ("downtime"), loss of time, inconvenience, cargo loss or damage, and other similar costs and expenses.

OBTAINING SERVICE

To obtain service under this Service Contract, return this vehicle to any IC Bus or International[®] truck dealer authorized to service this model bus and engine. To locate an authorized dealer near you, please call the Navistar Customer Service Center at 800-44-TRUCK (800-448-7825).

DISCLAIMER

FOLLOWING THE EXPIRATION OF THE STANDARD NAVISTAR LIMITED WARRANTY AND DURING THE PERIOD OF THIS SERVICE CONTRACT, NO WARRANTIES OR ADDITIONAL COVERAGE ARE GIVEN BEYOND THOSE DESCRIBED HEREIN. THIS EXTENDED WARRANTY IS IN LIEU OF ALL OTHER WARRANTIES, EXPRESSED OR IMPLIED, EXCEPT FOR THE APPLICABLE STANDARD NAVISTAR LIMITED WARRANTY FOR YOUR VEHICLE. NAVISTAR SPECIFICALLY DISCLAIMS WARRANTIES OF MERCHANTABILITY AND FITNESS FOR A PARTICULAR PURPOSE, ALL OTHER REPRESENTATIONS TO THE USER/PURCHASER, AND ALL OTHER OBLIGATIONS OR LIABILITIES. NAVISTAR FURTHER EXCLUDES LIABILITY FOR INCIDENTAL, SPECIAL, INDIRECT AND CONSEQUENTIAL DAMAGES, ON THE PART OF NAVISTAR OR SELLER. No person is authorized to give any other warranties or to assume any liabilities on Navistar's behalf unless specifically made or assumed in writing by Navistar; and no other person is authorized to give any warranties or to assume any liabilities on the seller's behalf unless specifically made or assumed in writing by the seller.

Remedies Under State or Provincial Law: Some States and Provinces do not allow the exclusion or limitation of incidental or consequential damages, so the above limitation or exclusion may not apply to the owner. This warranty gives the owner specific legal rights, and he may also have other legal rights which may vary by state or province.

Navistar, Inc., except in Canada where it is Navistar Canada, Inc.

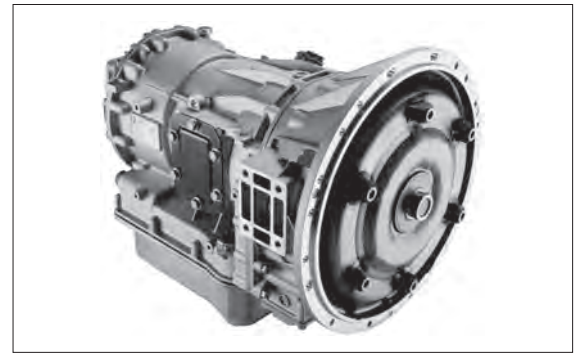

2500/2550 Series

International Series 2500/2550

RATINGS

Model ⁽¹⁾		Gross Input Torque ⁽²⁾ N•m	Gross Input Power ⁽²⁾ kW (hp)	Gross Input Torque ⁽²⁾⁽³⁾ N•m	Gross Input Power ⁽²⁾⁽³⁾ kW (hp)	GVW kg	GCW kg
2500	General	780	224 (300)	895	254 (340)	15,000	15,000
	Refuse, On-Highway	746	224 (300)	766	224 (300)	12,000	12,000
	Non-North America School Bus	705	149 (200)	750	164 (220)	15,000	15,000
2500 MH	Motorhome	746	224 (300)	895	254 (340)	15,000	15,000
2500 SP	Specialty Vehicles	CONTACT YOUR ALLISON REPRESENTATIVE FOR DETAILS					
2550	General	780	224 (300)	895	224 (300)	13,600	13,600
	Non-North America School Bus	705	149 (200)	750	149 (200)	13,600	13,600
2550 SP	Specialty Vehicles	CONTACT YOUR ALLISON REPRESENTATIVE FOR DETAILS					

(1). Models including vocational designations (ie: ORS, OF5, SP, MH) are for global markets. All other models within this document are targeted for outside North American markets only.
 (2). Gross ratings as defined by ISO 1585 or SAE J1995. (3). Shift Energy Management (SEM) engine controls and torque limiting are required to obtain this rating.

DRIVETRAIN INTERFACES

Acceptable full-load engine governed speed	2200 – 3800* rpm
Acceptable engine idle speed range (with transmission in Drive)	500 – 820 rpm
Maximum output shaft speed at 105 km/hr (65 mi/hr)	4500 rpm

* Engines with full load governed speed greater than 3800 rpm require Application Engineering review

MOUNTING

To Engine SAE No.3, SAE No.2

TORQUE CONVERTER

Type One stage, three element, polyphase.
Includes standard integral damper which is operational in lockup.

Model	Stall Torque Ratio
TC-210	2.05
TC-211	1.91
TC-221	1.73
TC-222	1.58

MECHANICAL RATIOS (Gear ratios do not include torque converter multiplication)

Range	
First	3.51 : 1
Second	1.90 : 1
Third	1.44 : 1
Fourth	1.00 : 1
Fifth	0.74 : 1
Sixth	0.64 : 1
Reverse	-5.09 : 1

CONTROL SYSTEM

Description Allison 5th Generation Electronic Controls with closed loop adaptive shifts

Shift Sequences [C = Converter mode (lockup clutch disengaged); L = Lockup mode (lockup clutch engaged)]

Option 1: 1C-[1L]-2C-2L-3L-4L-5L

Option 2: 1C-[1L]-2C-2L-3L-4L-5L-6L

Driver-to-Transmission Interface

Cab-mounted shift selector

Communication Protocol - Engine/Vehicle Systems Interface

SAE J1939, IESCAN, PT-CAN

PHYSICAL DESCRIPTION

	Installation Length*	Dry Weight	Depth below transmission centerline	
			With Shallow Oil Sump	With Deep Oil Sump
SAE No.3	729 mm	150 kg	272 mm	285 mm
SAE No.2	739 mm	150 kg	272 mm	285 mm

*Approximate length from engine housing to output flange (depending on output flange type)

TURBINE-DRIVEN POWER TAKE-OFF PROVISION

PTO drive	Torque converter turbine-driven spur gear
PTO mounting pads	Six-bolt, 3 o'clock and 9 o'clock positions (as viewed from rear)
PTO drive gear rating (continuous operation)	Using one PTO: 339 N•m Total using two PTO's: 271 N•m
PTO drive gear ratio	1.00 x turbine speed
PTO drive gear	64 tooth

OIL SYSTEM

Allison approved fluids: TES 295 and TES 389

Capacity, excluding external circuits

With Deep Oil Pan 14 litres

With Shallow Oil Pan 12 litres

Spin on canister filter Standard

SPEEDOMETER PROVISION

Description	Non-zero-crossing square wave
Location	8, 16 or 40 pulses per revolution of transmission output shaft Electronic output from TCM

TACHOGRAPH PROVISION

Tone wheel	6-tooth
Mounting Location	M18 x 1.5 metric thread Transmission rear cover

2500/2550 Series

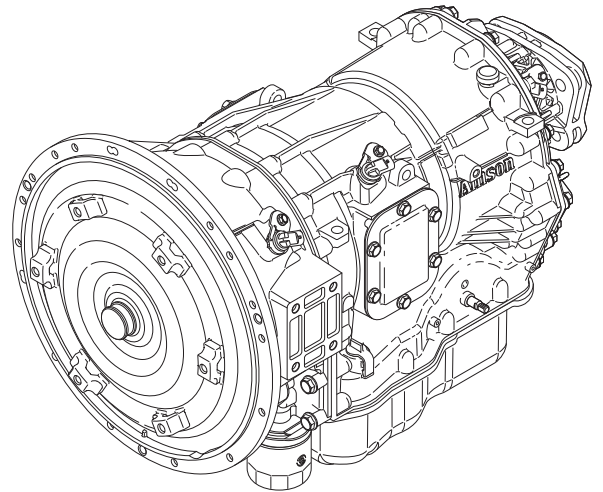
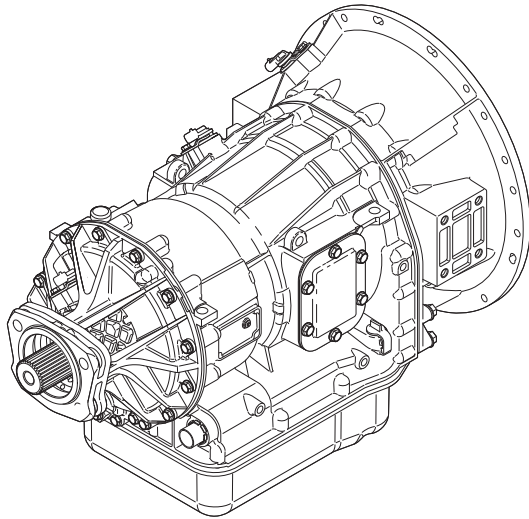



All IC School Buses come with: PROMOTIONAL PACKAGE 84 Month Unlimited Miles/km Warranty, Limited Time Program for Allison 2000 Series Transmission (Supplied directly through Allison)

Allison 3000 Series Transmission 60 Month Unlimited Miles/km Warranty (Supplied directly through Allison)

Cummins Warranty

All Engines United States And Canada School Bus

Coverage

Products Warranted

This Warranty applies to new diesel, LPG, compressed or liquid natural gas fueled Engines sold by Cummins Inc. or Cummins Westport and delivered to the first user on or after September 15, 1996, that are used in school bus* applications in the United States** or Canada.

Base Engine Warranty

The Base Engine Warranty covers any failures of the Engine which result, under normal use and service, from a defect in material or factory workmanship (Warrantable Failure). This Coverage begins with the sale of the Engine by Cummins and continues for five years or 100,000 miles (160,934 kilometers), whichever occurs first, from the date of delivery of the Engine to the first user.

Engine aftertreatment components included in the Cummins Critical Parts List (CPL) and marked with a Cummins part number are covered under Base Engine Warranty.

Extended Major Components Warranty

The Extended Major Components Warranty applies to all except ISV, ISB6.7 G, B and ISB Series Engines and covers Warrantable Failures of the Engine cylinder block, camshaft, crankshaft and connecting rods (Covered Parts).

Bushing and bearing failures are not covered.

This Coverage begins with the expiration of the Base Engine Warranty and ends three years or 300,000 miles (482,804 kilometers), whichever occurs first, from the date of delivery of the Engine to the first user.

Emission Warranty

Additional Coverage is outlined under the Emission Warranty.

THESE WARRANTIES ARE MADE TO ALL OWNERS IN THE CHAIN OF DISTRIBUTION AND COVERAGE CONTINUES TO ALL SUBSEQUENT OWNERS UNTIL THE END OF THE PERIODS OF COVERAGE.

Cummins Responsibilities

During The Base Engine Warranty

Cummins will pay for all parts and labor needed to repair the damage to the Engine resulting from a Warrantable Failure.

Cummins will pay for the lubricating oil, antifreeze, filter elements, belts, hoses and other maintenance items that are not reusable due to the Warrantable Failure.

Cummins will pay for reasonable labor costs for Engine removal and reinstallation when necessary to repair a Warrantable Failure.

Cummins will pay reasonable costs for towing a vehicle disabled by a Warrantable Failure to the nearest

authorized repair location when necessary to make the repair for the first 2 years from the date of delivery of the Engine to the first user. In lieu of towing expenses, Cummins will pay reasonable costs for mechanics to travel to and from the location of the vehicle, including meals, mileage and lodging, when the repair is performed at the site of the failure.

During The Extended Major Components Warranty

Cummins will pay for the repair or, at its option, replacement of the defective Covered Part and any Covered Part damaged by a Warrantable Failure of the defective Covered Part.

Owner Responsibilities

During The Base Engine Warranty

Owner is responsible for the cost of lubricating oil, antifreeze, filter elements and other maintenance items provided during Warranty repairs unless such items are not reusable due to the Warrantable Failure.

During The Extended Major Components Warranty

Owner is responsible for the cost of all labor needed to repair the Engine, including the labor to remove and reinstall the Engine. When Cummins elects to repair a part instead of replacing it, Owner is not responsible for the labor needed to repair the part.

Owner is responsible for the cost of all parts required for the repair except for the defective Covered Part and any Covered Part damaged by a Warrantable Failure of the defective Covered Part.

Owner is responsible for the cost of lubricating oil, antifreeze, filter elements and other maintenance items replaced during the repair.

During The Base Engine And Extended Major Components Warranties

Owner is responsible for the operation and maintenance of the Engine as specified in the applicable Cummins Operation and Maintenance Manual. Owner is also responsible for providing proof that all recommended maintenance has been performed.

Before the expiration of the applicable Warranty, Owner must notify a Cummins distributor, authorized dealer or other repair location approved by Cummins of any Warrantable Failure and make the Engine available for repair by such facility. Except for Engines disabled by a Warrantable Failure during the first two years from the date of delivery of the Engine to the first user, Owner must also deliver the Engine to the repair facility.

Service locations are listed on the Cummins Worldwide Service Locator at cummins.com.

Owner is responsible for communication expenses, meals, lodging and similar costs incurred as a result of a Warrantable Failure.

Owner is responsible for non-Engine repairs and for "downtime" expenses, passenger delays, fines, all applicable taxes, all business costs and other losses resulting from a Warrantable Failure.

Limitations

Engines with an emissions certification listed below must be operated using only diesel fuel having no more than the corresponding maximum sulfur content. Failure to use the specified fuel as listed in the Cummins Fuel Bulletin #3379001 Table 1 (Cummins Inc. Required Diesel Fuel Specifications) can damage the Engine and aftertreatment system within a short period of time. This damage could cause the Engine to become inoperable and failures attributable to the use of incorrect fuels will be denied Warranty Coverage. Fuel specifications also need to comply with local fuel regulations (EN590 for Europe and ASTM D975 for North America) for Warranty eligibility.

Maximum sulfur levels by emissions certification level as listed on the Engine's dataplate are:

EPA 2007/2010/2013/2017/2021	max. 15 parts per million
EPA Tier 4 Interim / Final / Stage V in North America	max. 15 parts per million
EU Stage IIIB 2011	max. 15 parts per million
EU Stage IV 2011	max. 15 parts per million
EU Stage V	max. 10 parts per million
Euro 4/5	max. 50 parts per million
Euro 6	max. 10 parts per million

Cummins is not responsible for failures or damage resulting from what Cummins determines to be abuse or neglect, including, but not limited to: operation without adequate coolants or lubricants; overfueling; overspeeding; lack of maintenance of lubricating, cooling or intake systems; improper storage, starting, warm-up, run-in or shutdown practices; unauthorized modifications of the Engine.

Any unauthorized modifications to the aftertreatment system could negatively affect emissions certification and void the Warranty.

Cummins is also not responsible for failures caused by incorrect oil, fuel or diesel exhaust fluid or by water, dirt or other contaminants in the fuel, oil or diesel exhaust fluid.

Alternators and starters are covered for the first two years from the date of delivery of the Engine to the first user, or the expiration of the Base Engine Warranty, whichever occurs first.

Excessive oil consumption for ISV and B Series Engines is covered for the duration of the Coverage. Before a claim for excessive oil consumption will be considered, Owner must submit adequate documentation to show that consumption exceeds Cummins published standards.

Failures of belts and hoses supplied by Cummins are not covered beyond the first year from the date of delivery of the Engine to the first user or the expiration of the applicable Base Engine Warranty, whichever occurs first.

Parts used to repair a Warrantable Failure may be new Cummins parts, Cummins approved rebuilt parts or repaired parts. Cummins is not responsible for failures resulting from the use of parts not approved by Cummins.

A new Cummins or Cummins approved rebuilt part used to repair a Warrantable Failure assumes the identity of the part it replaced and is entitled to the remaining Coverage hereunder.

Cummins, Inc. reserves the right to interrogate Electronic Control Module (ECM) data for purposes of failure analysis.

CUMMINS DOES NOT COVER WEAR OR WEAROUT OF COVERED PARTS.

CUMMINS IS NOT RESPONSIBLE FOR INCIDENTAL OR CONSEQUENTIAL DAMAGES.

THESE WARRANTIES AND THE EMISSION WARRANTY SET FORTH HEREINAFTER ARE THE SOLE WARRANTIES MADE BY CUMMINS IN REGARD TO THESE ENGINES. CUMMINS MAKES NO OTHER WARRANTIES, EXPRESS OR IMPLIED, OR OF MERCHANTABILITY OR FITNESS FOR A PARTICULAR PURPOSE.

This Warranty gives you specific legal rights, and you may also have other rights which vary from state to state.

Emission Warranty

Products Warranted

This Emission Warranty applies to new Engines marketed by Cummins that are used in the United States** or Canada in vehicles designed for transporting persons or property on a street or highway. This Warranty applies to Engines delivered to the ultimate purchaser on or after January 1, 1996.

Coverage

Cummins warrants to the ultimate purchaser and each subsequent purchaser that the Engine is designed, built and equipped so as to conform at the time of sale by Cummins with all U.S. federal emission regulations applicable at the time of manufacture and that it is free from defects in material or factory workmanship which would cause it not to meet these regulations within the longer of the following periods: (A) Five years or 100,000 miles (160,934 kilometers) of operation, whichever occurs first, as measured from the date of delivery of the Engine to the ultimate purchaser, or (B) The Base Engine Warranty.

If the vehicle in which the Engine is installed is registered in the state of California, a separate California Emission Warranty also applies.

Limitations

Engines with an emissions certification listed below must be operated using only diesel fuel having no more than the corresponding maximum sulfur content. Failure to use the specified fuel as listed in the Cummins Fuel Bulletin #3379001 Table 1 (Cummins Inc. Required Diesel Fuel Specifications) can damage the engine and aftertreatment system within a short period of time. This damage could cause the engine to become inoperable and failures attributable to the use of incorrect fuels will be denied Warranty Coverage. Fuel specifications also need to comply with local fuel regulations (EN590 for Europe and ASTM D975 for North America) for Warranty eligibility.

Maximum sulfur levels by emissions certification level as listed on the Engine's dataplate are:

EPA 2007/2010/2013/2017/2021	max. 15 parts per million
EPA Tier 4 Interim / Final / Stage V in North America	max. 15 parts per million
EU Stage IIIB 2011	max. 15 parts per million
EU Stage IV 2011	max. 15 parts per million
EU Stage V	max. 10 parts per million
Euro 4/5	max. 50 parts per million
Euro 6	max. 10 parts per million

Failures, other than those resulting from defects in material or factory workmanship, are not covered by this Warranty.

Cummins is not responsible for failures or damage resulting from what Cummins determines to be abuse or neglect, including, but not limited to: operation without adequate coolants or lubricants; overfueling; overspeeding; lack of maintenance of lubricating, cooling or intake systems; improper storage, starting, warm-up, run-in or shutdown practices; unauthorized modifications of the Engine.

Any unauthorized modifications to the aftertreatment system could negatively affect emissions certification and void the Warranty.

Cummins is also not responsible for failures caused by incorrect oil, fuel or diesel exhaust fluid or by water, dirt or other contaminants in the fuel, oil or diesel exhaust fluid.

Cummins is not responsible for non-Engine repairs, "downtime" expenses, cargo damage, fines, all applicable taxes, all business costs or other losses resulting from a Warrantable Failure.

CUMMINS IS NOT RESPONSIBLE FOR INCIDENTAL OR CONSEQUENTIAL DAMAGES.

* A vehicle used to transport students to and from school. Vehicle must be painted yellow, should have warning lights and the words 'SCHOOL BUS' written on the front

and rear roof caps. The requirements pertaining to paint color, warning lights and 'SCHOOL BUS' inscription would not apply if the vehicle is exclusively used to transport students for school related activities and it is owned by a school district.

** United States includes American Samoa, the Commonwealth of Northern Mariana Islands, Guam, Puerto Rico and the U.S. Virgin Islands.

B6.7™

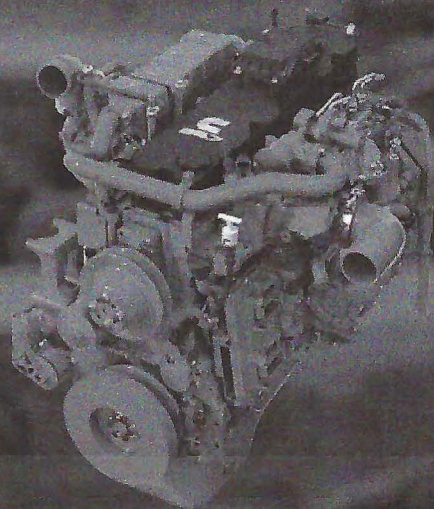

PROVEN TRACK RECORD

The Cummins B6.7™ is one of the most dependable, durable and reliable medium-duty engines available. It's been tested and proven with more than 12 million engines produced over nearly 40 years, with billions of miles driven. These figures aren't just milestones either. They represent years of experience learning and optimizing the product into what we produce today – the most reliable B6.7 Cummins has ever built. We're proud of this history and proud that Cummins medium-duty products power more school buses in operation across North America than any other engines.

REDUCED OPERATING COSTS

We know total cost of operation (TCO) is important to our customers, which is why we focused on making enhancements to reliability and durability while also lowering the TCO. New for EPA 2021, the B6.7 features upgrades that allow for extended engine maintenance intervals, including longer oil drain intervals, more time between fuel filter changes and a completely maintenance-free crankcase ventilation filter. Also new for 2021, the B6.7 offers advancements in connectivity to find, prevent and resolve issues faster.

WE HAVE YOUR BACK

The B6.7 comes with a 5-year / 100,000-mile base warranty. For added peace of mind, we offer multiple extended coverage plan options up to 10 years, designed to provide you with the coverage you need for your operation. All Cummins products are backed by the largest, most capable support network in North America. With over 3,700 certified repair locations across the U.S. and Canada, your school buses are never far from a Cummins-certified technician.

B6.7 MAINTENANCE INTERVALS

Maintenance Item	Miles/ Kilometers	Hours	Months
*Oil and Filter	30,000 mi/48,000 km	1,000	18
Fuel Filter	60,000 mi/96,000 km	2,000	18
Overhead Adjustment	150,000 mi/240,000 km	5,000	48
Coolant Check	15,000 mi 24,000 km	500	6
DEF Filter	200,000 mi 320,000 km	6,500	N/A
Particulate Filter Cleaning	200,000 mi 320,000 km	6,500	N/A
Crankcase Ventilation Filter	N/A	N/A	N/A

* With a 19-quart oil pan. Duty-cycle dependent.

Consult your Operation and Maintenance Manual for more information.

B6.7 SCHOOL BUS RATINGS

Engine Model	Advertised HP (kW)	Peak Torque LB-FT (N•m) @ RPM	Governed Speed
B6.7 260	260 (194)	660 (896) @ 1600	2600
B6.7 250	250 (187)	660 (896) @ 1600	2600
B6.7 240	240 (179)	560 (760) @ 1600	2600
B6.7 220	220 (164)	600 (814) @ 1600	2600
B6.7 220	220 (164)	520 (206) @ 1600	2600
B6.7 200	200 (149)	520 (206) @ 1600	2600

OVER THE AIR PROGRAMMING CAPABILITY.

When connected to a compatible and participating telematics system, Cummins Connected Software Updates facilitate engine control module calibrations remotely in about five minutes, which slashes downtime by eliminating a traditionally scheduled visit to the service bay. Once Cummins Connected Software Updates have been integrated, customers can leverage the same technology to take advantage of Cummins full upcoming suite of over-the-air programming solutions designed to enhance performance, safety and fuel efficiency.

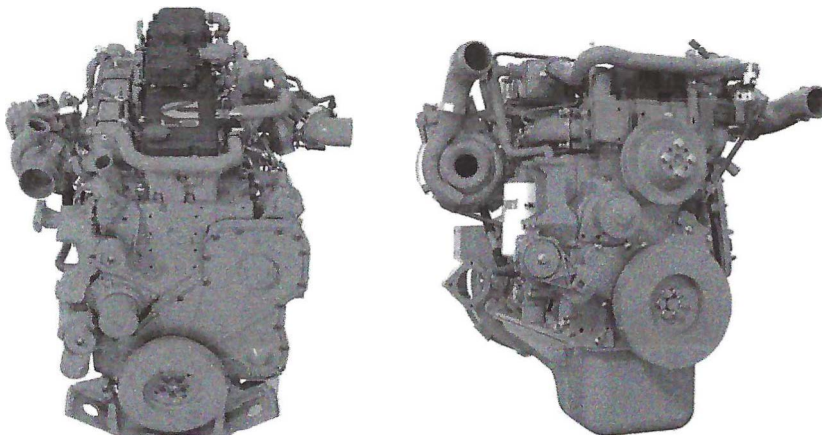

Cummins Inc.
Box 3005
Columbus, IN 47202-3005
U.S.A.

1-800-CUMMINS™ (1-800-286-6467)
cummins.com

Bulletin 5544101 Printed in U.S.A. Rev. 9/20
©2020 Cummins Inc.



Bendix® Wingman® Advanced™

A Collision Mitigation Technology



Bendix



A powerful combination of collision mitigation and full stability technologies

WINGMAN
Advanced

Bendix® Wingman® Advanced™



The Key is Active Braking

The Bendix® Wingman® Advanced™ system is the latest innovation for school buses from the industry leader in active braking technologies – Bendix Commercial Vehicle Systems. Bendix Wingman Advanced brings together adaptive cruise control with braking features along with collision mitigation technology, and our full-stability technology – Bendix® ESP® – providing your fleet with a system that can help. Your fleet benefits from a potent combination of active safety technologies that can help your drivers in collisions, roll-overs, and loss-of-control situations. In addition, the system can provide data, to help keep you in the know about what's happening out on the road.

Helping your drivers on the roadway

When the distance between your driver's bus and the vehicle they're following starts to close, Bendix Wingman Advanced provides the driver following distance alerts and, if necessary, will apply the brakes to help the driver potentially avoid the collision, or help reduce its severity.

Bendix Wingman Advanced features stationary object alerts. These alerts give the driver a warning (up to 3.0 seconds) of a metallic object, such as a stalled car, blocking the lane of travel.

Providing information you can use

Performance on the road is important, but you also need actionable information to know what's happening out there. The Bendix Wingman Advanced system can deliver important data your school bus fleet can use, such as following distance information, alerts given, and stability events. Knowing about close calls and other insights from the road can help you assess and update your driver training needs and support fleet operations.

Making a positive contribution to your bottom line

It's all about getting a quick return on your safety investment. The Bendix Wingman Advanced system helps your fleet in multiple ways. By helping drivers potentially avoid rear-end collisions or, at least, help reduce their severity, your fleet may see fewer accidents and less accident-related costs. Also, a number of alerts will now be available to drivers to help them on their daily routes, such as an impact alert, stationary object alert, and following distance alerts, which should increase safety and reduce accident-related costs.

Bendix® Wingman® Advanced™ Features

Alerts (are always available whether cruise control is engaged or not)

- *Following Distance Alerts* – audible and visual alerts which let drivers know when getting too close to a forward vehicle ✓
- *Impact Alerts* – audible and visual alerts warning the driver that a collision with the forward vehicle is likely and that they should address the situation immediately ✓
- *Stationary Object Alerts* – audible and visual alerts that provide the driver up to a 3.0 second alert when a metallic object(s) may be blocking the lane of travel ✓

Adaptive Cruise Control with Braking (functions when cruise control is on and speed is set)

- Reduces throttle to help the driver maintain a set following distance behind a forward vehicle ✓
- Engages the engine retarder to help the driver maintain a set following distance behind a forward vehicle ✓
- Applies the foundation brakes to help the driver maintain a set following distance behind a forward vehicle ✓

Electronic Stability System

- Bendix® ESP® full stability system to help drivers mitigate rollovers and loss-of-control situations on wet and dry roadways ✓

Collision Mitigation (functions whether or not cruise control is on and speed is set)

- Provides audible and visual alerts to the driver and applies the brakes when the system determines a collision with a forward vehicle is imminent ✓



The Bendix Wingman Advanced system doesn't replace the need for safe drivers

No school bus safety technology replaces the most important safety components of all – a skilled, alert professional driver exercising safe driving habits, as well as continuous, comprehensive driver training. Responsibility for the safe operation of the vehicle remains with the driver at all times.

Warranty Coverage 36 Months, 350,000 Miles

The Key is Active Braking



Help your drivers & your students everywhere, every day...

The Bendix® Wingman® Advanced™ system:

Provides more control on slick surfaces;

Apply the brakes automatically on a slick or icy roadway and the risk of losing control increases. Bendix Wingman Advanced is built on the Bendix® ESP® full stability system. Full stability does more than roll-only systems to help keep school buses under control when brakes are automatically applied on slick surfaces.

Delivers more braking power when your drivers need it;

Bendix Wingman Advanced delivers up to 2/3 (67%) of vehicle braking power. By building on a full-stability platform, all brakes – steer & drive – are available and can be controlled as necessary to provide maximum braking power and a more even braking distribution.

Less wear and tear on your brakes which equals lower maintenance costs, less vehicle downtime;

The adaptive cruise control with braking feature of Bendix Wingman Advanced helps your drivers keep a set following distance by reducing throttle, engaging the engine retarder or, if necessary, applying the brakes. This progressive approach means brakes only get used when they're really needed resulting in less brake wear and more savings.

Delivers "Always Available" driver alerts;

As following distance closes, drivers receive unique visual and audible warnings to aid their response. Fewer false warnings means drivers react when the system alerts.

Alerts drivers to stationary road hazards;

Stationary object alert can provide drivers with an extra warning about metallic objects such as standing vehicles blocking their lane of travel day or night, rain or shine, fog or snow.

Provides useful information; and

Delivers valuable data about following distance, alerts, and stability interventions that you can use to help target driver training needs.

Cost justified, proven safety.

Potentially avoiding a collision or reducing the severity of just one crash can add up to substantial savings from accident and other related costs. With young lives at stake, safety for students is always a number one priority.

For complete details about the Bendix® Wingman® Advanced™ system, contact your Bendix Account Manager, call 1-800-AIR-BRAKE (1-800-247-2725), or visit bendix.com today.

Bendix® ESP® stability for added protection and performance

Bendix ESP, with over 600,000 systems delivered, is an integral part of the Bendix Wingman Advanced system, helping your drivers mitigate roll-over and loss-of-control situations on dry, wet, snow and ice-covered pavement. Plus, Bendix ESP helps Bendix Wingman Advanced use more brakes on the vehicle to deliver more braking power and better balanced brake applications.



IC Bus Servicing Dealers

International Dealer	Address	Phone
Border International Trucks El Paso	12283 Rojas Dr, El Paso, TX 79936	(915) 858-4644
Graham International Inc Sherman	5800 Texoma Pkwy, Sherman, TX 75090	(903) 892-2122
Graham International, Inc. Paris	2945 NE Loop 286, Paris, TX 75460	(903) 784-6683
Kyrish Truck Center of Houston	14201 Hempstead Rd, Houston, TX 77040	(713) 690-1700
Kyrish Truck Center of Houston	8900 N Loop E Fwy, Houston, TX 77029	(713) 674-3444
Kyrish Truck Center of Pharr	711 N Cage Blvd, Pharr, TX 78577	(956) 961-4681
Kyrish Truck Center of Victoria	2605 Port Lavaca Dr, Victoria, TX 77901	(361) 575-1481
Kyrish Truck Centers of Austin North	16336 N. Interstate 35, Austin, TX 78728	(512) 813-6868
Kyrish Truck Centers of Austin South	5010 Burleson Rd, Austin, TX 78744	(512) 389-1111
Kyrish Truck Centers of Beaumont	2465 W Cardinal Dr, Beaumont, TX 77705, USA	(409) 617-0975
Kyrish Truck Centers of Bryan	4050 Hwy 21 East, Bryan, TX 77808	(979) 778-7481
Kyrish Truck Centers of Corpus Christi	7749, I-37, Corpus Christi, TX 78409	(361) 289-5151
Kyrish Truck Centers of Temple	6043 N General Bruce Dr., Temple, TX 76501	(254) 778-3648
Kyrish Trucks Centers of San Antonio, TX	1380 Ackerman Rd, San Antonio, TX 78219	(210) 661-8371
Longhorn Bus Sales	9100 N Loop E Fwy, Houston, TX 77029	(713) 631-9306
Longhorn Bus Sales South	221 W Expy 83, La Feria, TX 78559	(956) 797-3006
Pliier International	3016 S Eastman Rd, Longview, TX 75602	(903) 758-3351
Price International Trucks Tyler	5033 HIGHWAY 271 N, Tyler, TX 75708	(903) 225-4042
Roberts Truck Center Amarillo	4378 Canyon Dr, Amarillo, TX 79109	(806) 355-9771
Roberts Truck Center Lubbock	4510 Avenue A, Lubbock, TX 79404	(806) 763-8213
Roberts Truck Center Midland	10101 I-20 Frontage, Midland, TX 79706	(432) 697-2241
Roberts Truck Center San Angelo	617 N Bell St, San Angelo, TX 76903	(325) 655-7187
Roberts Truck Center Tye	550 S Access Rd, Tye, TX 79563	(325) 677-3393
Rotex Truck Center Lerado	11802 Sara Rd, Laredo, TX 78045	(956) 722-1250
Southwest International Trucks Arlington	2401 E Pioneer Pkwy, Arlington, TX 76010	(817) 664-2900
Southwest International Trucks Fort Worth	617 North Fwy, Fort Worth, TX 76102	(817) 336-4651
Southwest International Trucks McKinney	2105 N Central Expy, McKinney, TX 75070	(972) 629-3600
Southwest International Trucks Waco	3920 N Interstate 35 Frontage Rd South, Waco, TX 76706	(254) 340-6700
Southwest International Trucks, Inc.	3722 Irving Blvd, Dallas, TX 75247	(214) 689-1400
Summit Truck Group Wichita Falls	2401 Central E Fwy, Wichita Falls, TX 76302	(940) 322-7845

IC Bus Servicing Dealers

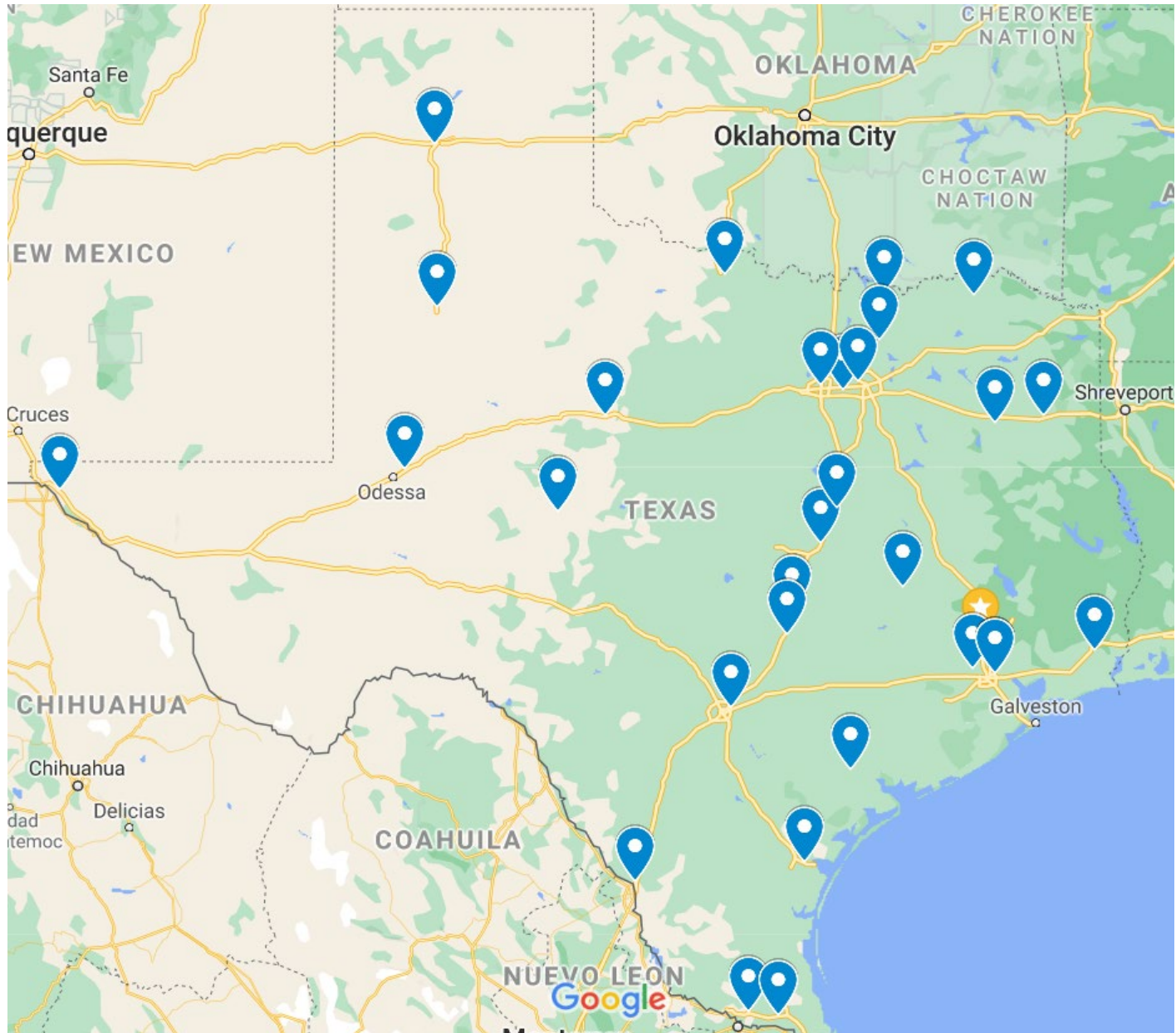



CE SCHOOL BUS

Sales Proposal For:
Medina Valley ISD

Presented By:
LONGHORN BUS SALES

Prepared For:
Medina Valley ISD
TOBIE KENNEDY
8449 F M 471 South
Castroville, TX 78009-
(830)931 - 2867

Presented By:
LONGHORN BUS SALES
FRED HOKE
9100 N LOOP E
HOUSTON TX 77029 -
(713)631-9306

Reference ID: 10 71P DSL 3PT

Model Profile
2025 CE SCHOOL BUS (PB110)

AXLE CONFIG:	4X2
APPLICATION:	School Transportation
MISSION:	Requested GVWR: 31000. Calc. GVWR: 31000 Calc. Start / Grade Ability: 27.43% / 2.27% @ 55 MPH Calc. Geared Speed: 79.2 MPH
DIMENSION:	Wheelbase: 276.00, CA: N/A, Axle to Frame: 166.00
ENGINE, DIESEL:	{Cummins B6.7 260} EPA 2024, 260HP @ 2400 RPM, 660 lb-ft Torque @ 1600 RPM, 2600 RPM Governed Speed, 260 Peak HP (Max), School Bus Only
TRANSMISSION, AUTOMATIC:	{Allison 2500 PTS} 6th Generation Controls, Wide Ratio, 6-Speed with Double Overdrive, Less PTO Provision, Less Retarder, with 33,000-lb GVW and GCW Max, School Bus
CLUTCH:	Omit Item (Clutch & Control)
AXLE, FRONT NON-DRIVING:	{Meritor MFS-10-122A} I-Beam Type, 10,000-lb Capacity
AXLE, REAR, SINGLE:	{Dana Spicer S140} Single Reduction, 21,000-lb Capacity, 190 Wheel Ends Gear Ratio: 6.14
TIRE, FRONT:	(2) 11R22.5 Load Range H R89 ALL POSITION (PIRELLI), 501 rev/mile, 75 MPH, All-Position
TIRE, REAR:	(4) 11R22.5 Load Range H R89 ALL POSITION (PIRELLI), 501 rev/mile, 75 MPH, All-Position
SUSPENSION, REAR, AIR, SINGLE:	{International IROS} 21,000-lb Capacity, 9.25" Ride Height, with Shock Absorbers Mounted Outside the Rails
PAINT:	Cab schematic 100NB Location 1: 4421, School Bus Yellow (Std) Chassis schematic N/A

Vehicle Specifications
2025 CE SCHOOL BUS (PB110)

February 08, 2024

Code	Description
PB11000	Base Chassis, Model CE SCHOOL BUS with 276.00 Wheelbase, N/A CA, and 166.00 Axle to Frame.

BODY PLANS

47AMG	BODY, BUS Conventional; 78" Headroom, 34'11" Body Length, +9 Section Rear, 81 Passenger, 276 WB <u>Includes</u> : NOTE: Body Mandates Overall Vehicle Length of Greater than 40 Feet
OBD001	BODY PLAN, NON-SPECIAL NEEDS USE 50ZDN/49001
49001	BODY PLAN, APPROVED VARIATION Number 001

AXLE CONFIGURATION

1ANA	AXLE CONFIGURATION {Navistar} 4x2
------	-----------------------------------

ENGINE

12EYJ	ENGINE, DIESEL {Cummins B6.7 260} EPA 2024, 260HP @ 2400 RPM, 660 lb-ft Torque @ 1600 RPM, 2600 RPM Governed Speed, 260 Peak HP (Max), School Bus Only
12VJR	EMISSION, CALENDAR YEAR {Cummins B6.7} EPA, OBD and GHG Certified for Calendar Year 2024
12XCS	CARB EMISSION WARR COMPLIANCE Does Not Comply with CARB Emission Warranty
12WZE	CARB IDLE COMPLIANCE Does Not Comply with California Clean Air Idle Regulations
12WVG	EPA IDLE COMPLIANCE Low NOx Idle Engine, Complies with EPA Clean Air Regulations; Includes "Certified Clean Idle" Decal on Hood
12XCC	RADIATOR Aluminum, 2-Row, Down Flow, Front to Back System, 640 SqIn Louvered, with 383 SqIn Charge Air Cooler, Includes In-Tank Oil Cooler <u>Includes</u> : RADIATOR HOSES Premium, Rubber
12TSY	FAN DRIVE {Borg-Warner SA85} Viscous Type, Screw On <u>Includes</u> : FAN Nylon
12VCE	AIR CLEANER Single Element, Fire Retardant Media
12703	ANTI-FREEZE Red, Extended Life Coolant; To -40 Degrees F/ -40 Degrees C, Freeze Protection
12VVN	CRUISE CONTROL Electronic
12VYV	IDLE MANAGEMENT SYSTEM Ramp Engine Speed with Air Condition On, in Neutral and Parking Brake Set, Accommodation Package
12WPV	OIL PAN 15 Quart Capacity, For Cummins ISB/B6.7 Engines
12UGN	THROTTLE, HAND CONTROL Electronic

TRANSMISSION

13BBP	TRANSMISSION, AUTOMATIC {Allison 2500 PTS} 6th Generation Controls, Wide Ratio, 6-Speed with Double Overdrive, Less PTO Provision, Less Retarder, with 33,000-lb GVW and GCW Max, School Bus
13WVW	NEUTRAL AT STOP OMIT
13WYY	SHIFT CONTROL PARAMETERS {Allison} 1000 or 2000 Series Transmissions, Performance Programming
13WLN	TRANSMISSION OIL Synthetic; 20 thru 28 Pints

Vehicle Specifications
2025 CE SCHOOL BUS (PB110)

February 08, 2024

Code	Description
13WEX	TRANSMISSION SHIFT CONTROL Column Mounted Stalk Shifter, for Allison 1000 & 2000 Series Transmission

CLUTCH

11001	CLUTCH Omit Item (Clutch & Control)
-------	-------------------------------------

REAR AXLES, SUSPENSIONS

14AKC	AXLE, REAR, SINGLE {Dana Spicer S140} Single Reduction, 21,000-lb Capacity, 190 Wheel Ends . Gear Ratio: 6.14
14TDV	SUSPENSION, REAR, AIR, SINGLE {International IROS} 21,000-lb Capacity, 9.25" Ride Height, with Shock Absorbers Mounted Outside the Rails

FRONT AXLES

2ASH	AXLE, FRONT NON-DRIVING {Meritor MFS-10-122A} I-Beam Type, 10,000-lb Capacity
------	---

FRONT SUSPENSIONS

3ADB	SUSPENSION, FRONT, SPRING Parabolic Taper Leaf, Shackle Type, 10,000-lb Capacity, with Shock Absorbers <u>Includes</u> : SPRING PINS Rubber Bushings, Maintenance-Free
------	--

CABS, COWLS, BODIES

16010	COWL Flat Back
16BAM	AIR CONDITIONER with Integral Heater and Defroster
16VKB	CAB INTERIOR TRIM Classic, for Day Cab
16GEG	GAUGE CLUSTER Premium Level; English with English Electronic Speedometer <u>Includes</u> : GAUGE CLUSTER DISPLAY: Base Level (3" Monochromatic Display), Premium Level (5" LCD Color Display); Odometer, Voltmeter, Diagnostic Messages, Gear Indicator, Trip Odometer, Total Engine Hours, Trip Hours, MPG, Distance to Empty/Refill for : GAUGE CLUSTER Speedometer, Tachometer, Engine Coolant Temp, Fuel Gauge, DEF Gauge, Oil Pressure Gauge, Primary and Secondary Air Pressure or Auxiliary Air Pressure (if Air Equipped) : WARNING SYSTEM Low Fuel, Low DEF, Low Oil Pressure, High Engine Coolant Temp, Low Battery Voltage (Visual and Audible), Low Air Pressure, Primary and Secondary (if Air Equipped)
16HLJ	GAUGE, DEF FLUID LEVEL
16HGH	GAUGE, OIL TEMP, AUTO TRANS for Allison Transmission
16563	HEATER SHUT-OFF VALVES (2) Ball Valve Type
16XJP	INSTRUMENT PANEL Wing Panel
16HKT	IP CLUSTER DISPLAY On Board Diagnostics Display of Fault Codes in Gauge Cluster
16VVJ	WINDSHIELD Three Piece, Bonded, with Shaded Band

FRAMES

1CAC	FRAME RAILS High Strength Low Alloy Steel (50,000 PSI Yield); 10.125" x 3.062" x 0.312" (257.2mm x 77.8mm x 8.0mm); 489.2" (12425mm) Maximum OAL
------	--

Vehicle Specifications
2025 CE SCHOOL BUS (PB110)

February 08, 2024

Code	Description
1LSG	BUMPER, FRONT Contoured, Steel, Painted Gloss Black, Severe Duty <u>Notes</u> : Bumper Thickness is .25"
1LNW	CROSSING GATE, FRONT Air, Yellow Blade, Bumper Mounted <u>Includes</u> : CONTROL ASSEMBLY Located Rear of Front Bumper, Heater not Required : CROSSING GATE, FRONT Matches Contour of Bumper
1SAL	CROSSMEMBER, REAR, AF (1)
1WJE	WHEELBASE RANGE 276" (700cm) Only

BRAKES

4091	BRAKE SYSTEM, AIR Dual System for Straight Truck Applications <u>Includes</u> : BRAKE LINES Color and Size Coded Nylon : DRAIN VALVE Twist-Type : GAUGE, AIR PRESSURE (2) Air 1 and Air 2 Gauges; Located in Instrument Cluster : QUICK RELEASE VALVE On Rear Axle for Spring Brake Release: 1 for 4x2, 2 for 6x4 : SPRING BRAKE MODULATOR VALVE R-7 for 4x2, SR-7 with relay valve for 6x4/8x6
4AZS	AIR BRAKE ABS {Bendix AntiLock Brake System} 4-Channel (4 Sensor/4 Modulator) Electronic Stability Program, with Automatic Traction Control
4GBL	BRAKE, PARKING {Bendix Intellipark} Electronic Park Brake, for Truck or Bus Applications
4XDD	BRAKES, FRONT {Meritor 15X5 Q-PLUS CAST} Air S-Cam Type, Cast Spider, Fabricated Shoe, Double Anchor Pin, Size 15" X 5", 13,200-lb Capacity
4EXP	BRAKE CHAMBERS, FRONT AXLE {Bendix} 20 Sqn
4LAG	SLACK ADJUSTERS, FRONT {Gunite} Automatic
4XDR	BRAKES, REAR {Meritor 16.5X7 Q-PLUS CAST} Air S-Cam Type, Cast Spider, Fabricated Shoe, Double Anchor Pin, Size 16.5" X 7", 23,000-lb Capacity per Axle
4EXU	BRAKE CHAMBERS, REAR AXLE {Bendix EverSure} 30/30 Sqn Spring Brake
4LGG	SLACK ADJUSTERS, REAR {Gunite} Automatic
4SPA	AIR COMPRESSOR {Cummins} 18.7 CFM
4EDN	AIR DRYER {Bendix AD-9SI} with Heater, Includes Safety Valve
4VLE	AIR DRYER LOCATION Mounted Inside Engine Compartment, Right Side
4VLY	AIR TANK LOCATION (1) Mounted Inside & Below Left Rail, Back of Cab
4722	DRAIN VALVE {Bendix DV-2} Automatic, with Heater, for Air Tank
4WZT	GVWR LIMITATION FOR BUS with Air Brakes, Limited to 33,000-lbs Maximum to meet FMVSS 121 Requirements, for Conventional Bus
4WJP	PARKING BRAKE INTERLOCK with Electronic Park Brake, Parking Brake Cannot be Released Until Ignition Switch is in "On" Position and Service Brake Pedal is Applied, Use with Air Brake Chassis Only

STEERING

5PSA	STEERING GEAR {Sheppard M100} Power
5708	STEERING COLUMN Tilting

Vehicle Specifications
2025 CE SCHOOL BUS (PB110)

February 08, 2024

Code	Description
5CAW	STEERING WHEEL 4-Spoke; 18" Dia., Black

DRIVELINES

6DGA	DRIVELINE SYSTEM {Dana Spicer} SPL100, for 4x2/6x2
6901	PROPSHAFT GUARD

EXHAUST SYSTEMS

7BMK	EXHAUST SYSTEM Horizontal Aftertreatment System, Frame Mounted Under Right Rail, for Single Long Horizontal Tail Pipe
7SCP	ENGINE EXHAUST BRAKE for Cummins ISB/B6.7/ISL/L9 Engine with Variable Vane Turbo Charger
7WCX	HEAT SHIELD Between Exhaust & Fuel Tank, Mounted to AF Crossmember
7WBL	TAIL PIPE (1) Horizontal, Long, Exits Left Side Through Bumper

ELECTRICAL SYSTEMS

8000	ELECTRICAL SYSTEM 12-Volt, Standard Equipment <u>Includes</u> : HAZARD SWITCH Push On/Push Off, Located on Instrument Panel to Right of Steering Wheel : HEADLIGHT DIMMER SWITCH Integral with Turn Signal Lever : MISCELLANEOUS FEATURES Modular, Loom Protected, Grommets in all Applicable Body Openings, Assembled in Computer Assisted Fixture which Verifies Continuity and Correct Assembly Prior to Installation : PARKING LIGHT Integral with Front Turn Signal and Rear Tail Light : STARTER SWITCH Electric, Key Operated : TURN SIGNAL SWITCH Self-Cancelling with Lane Change Feature : TURN SIGNALS, FRONT Includes Reflectors and Auxiliary Side Turn Signals, Solid State Flashers; Flush Mounted : WINDSHIELD WIPER SWITCH 2-Speed with Wash and Intermittent Feature (5 Pre-Set Delays), Integral with Turn Signal Lever : WIRING, CHASSIS Color Coded and Continuously Numbered
8GXN	ALTERNATOR {Leece-Neville BLP4024N} Brushless, 12 Volt, 325 Amp Capacity, Pad Mount, with Remote Sense
8RPP	ANTENNA Shark Fin, Roof Mounted
8TTK	BATTERY BOX Steel, with Sliding Tray, 25.25" Wide, for Standard Batteries, 1-3 Battery Capacity, Mounted Left Side Behind Front Axle Perpendicular to Frame Rail
8MJU	BATTERY SYSTEM {Fleetrite} Maintenance-Free, (3) 12-Volt 2850CCA Total, Top Threaded Stud
8XDX	BK WARN IND,PARK BK NOT SET Visual and Audible Alarm, Active Upon Ignition Off and Parking Brake Not Set, Reminder to Set Parking Brake
8XAH	CIRCUIT BREAKERS Manual-Reset (Main Panel) SAE Type III with Trip Indicators, Replaces All Fuses
8TPL	COLLISION MITIGATION SYSTEM {Bendix Wingman Advanced} Adaptive Cruise Control with Collision Mitigation and Stationary Object Alert; Includes Front Radar, Driver Display
8WXB	HEADLIGHT WARNING BUZZER Sounds When Head Light Switch is on and Ignition Switch is in "Off" Position
8XKC	HEADLIGHTS Halogen, with Daytime Running Lights, Automatic Twilight Controlled
8WRB	HEADLIGHTS ON W/WIPERS Headlights Will Automatically Turn On if Windshield Wipers are Turned On
8540	HORN, ELECTRIC (2) Trumpet Style
8WWJ	INDICATOR, LOW COOLANT LEVEL with Audible Alarm

Vehicle Specifications
2025 CE SCHOOL BUS (PB110)

February 08, 2024

Code	Description
8RRC	RADIO AM/FM/USB Input/Auxiliary Input, Includes Wiring and Antenna, with Public Address System
8XKL	STARTING MOTOR {Mitsubishi Electric Automotive America 90P47} 12-Volt, with Soft-Start
8XPN	USB PORT One USB-A Port and One USB-C Port, Located in Instrument Panel

FRONT END

9WBW	FRONT END Tilting, Fiberglass, with Three Piece Construction, Dual Air Intakes
9HCY	GRILLE Molded in Black, with Chrome Surround
9WAB	HOOD TILT ASSIST {EASY TILT} Mechanical
9HBN	INSULATION, SPLASH PANELS for Sound Abatement
9HAN	INSULATION, UNDER HOOD for Sound Abatement
9AAB	LOGOS EXTERIOR Model Badges
9AAE	LOGOS EXTERIOR, ENGINE Badges

SPEEDOMETER, TOOLS, MISC

10020	CHASSIS PAINT Full Chassis
10AGB	COMMUNICATIONS MODULE Telematics Device with Over the Air Programming; Includes Five Year Data Plan and International 360
10WUE	MUD FLAPS, FRONT WHEELS (2) Rubber, Mounted on Fender Extension
10060	PAINT SCHEMATIC, PT-1 Single Color, Design 100 <u>Includes</u> : PAINT SCHEMATIC ID LETTERS "NB"
10788	PAINT TYPE Urethane, One or Two Colors, Other than Imron or International.
10XAK	PROMOTIONAL PACKAGE 7 Year Unlimited Miles/km Warranty, Limited Time Program for Allison 2500 Series Transmission on School and Commercial Buses (Supplied directly through Allison)

FUEL TANKS

15SLL	FUEL TANK Top Draw, Steel, Rectangular, 100 US Gal (379L), Includes Protective Cage, Mounted Between Frame Rails and Behind Rear Axle
15WEP	DEF TANK 16.5 US Gal (62.5L) Capacity, Frame Mounted Outside Right Rail, Behind 0 Bow
15LMR	FUEL/WATER SEPARATOR {Racor 400 Series,} with Primer Pump, Includes Water-in-Fuel Sensor
15LRE	LOCATION FUEL/WATER SEPARATOR Mounted Under Hood, Left Side, Above Front Axle

WHEELS, TIRES - FRONT

27DUW	WHEELS, FRONT {Accuride 51408} DISC; 22.5x8.25 Rims, Powder Coat Steel, 2-Hand Hole, 10-Stud, 285.75mm BC, Hub-Piloted, Flanged Nut, with Steel Hubs
7382135503	(2) TIRE, FRONT 11R22.5 Load Range H R89 ALL POSITION (PIRELLI), 501 rev/mile, 75 MPH, All-Position

WHEELS, TIRES - REAR

28DUW	WHEELS, REAR {Accuride 51408} DUAL DISC; 22.5x8.25 Rims, Powder Coat Steel, 2-Hand Hole, 10-Stud, 285.75mm BC, Hub-Piloted, Flanged Nut, with Steel Hubs
-------	--

Vehicle Specifications
2025 CE SCHOOL BUS (PB110)

February 08, 2024

<u>Code</u>	<u>Description</u>
7382135503	(4) TIRE, REAR 11R22.5 Load Range H R89 ALL POSITION (PIRELLI), 501 rev/mile, 75 MPH, All-Position

WHEELS, SPARE

26DUW	WHEEL, SPARE, DISC {Accuride 51408} 22.5x8.25 Rims, Powder Coat Steel, 10-Stud, 285.75mm BC, Hub-Piloted
-------	--

BODY FEATURES

47BAK	BUMPER, REAR Painted, 12" High, 3/16" Thick
47BAR	SUPPORTS, REAR BUMPER Bolted to Frame
47AYB	BODY, REAR Includes Emergency Door
47ARH	BOWS, ROOF 14 ga., One Piece Construction <u>Includes</u> : BOWS, ROOF Positioned Floor Line to Floor Line, Threaded Through Roof Strainers and Drip Rail
47BLU	FASTENERS, EXTERIOR MOUNTED Stainless Steel Screws; for All Exterior Body Lights, Body Exterior Rear View Mirrors, Bumper Mounted Crossing Gate and Body Mounted Stop Arms
47APX	FASTENERS, HEADLINER Screws
47AZL	FLOOR, BODY with Wheel Wells
47PBZ	HANDLE, ASSIST Windshield Side Mounted, Left and Right, Body Color
47APR	HEADLINER, BODY Conventional; 25'11"-35'08" Body Length, Perforated Full Length with Sound Insulation Full Length
47ARP	LIGHT BARS Plastic
47BBH	LINING, SIDE INTERIOR, LOWER Embossed Steel, Clear Coated
47AXT	RUB RAILS, BODY (4) Conventional; Steel, 31'2", 31'11", 32'8", 33'5", 34'2", 34'11", 35'8" Body Lengths, Includes Snow Rail <u>Includes</u> : RUB RAILS Full Length, Primer Coated (Both Sides), Attached to Body without Cuts or Splices
47BBZ	SEALER Extra; Sidewall to Floor, In Wheel Pocket Area, and Rear Wall to Floor
47AZE	SIDE SHEET, BODY, EXTERIOR Conventional, 16ga., Smooth, 31'2", 31'11", 32'8", 33'5", 34'2", 34'11", 35'8" Body Lengths
47ASG	SKIRT, BODY for Conventional, 14 1/2", 16ga <u>Includes</u> : SKIRT, BODY Extra Smooth Steel Supported by Floor Gussets
47BLD	STEP, FRONT ENTRANCE DOOR 27 1/4" Depth; 14ga Steel, Formed Treads, Naviflex Finish
47AUR	TIE DOWNS, BODY Grade 8 Bolts, Every Body Section <u>Includes</u> : TIE DOWNS, BODY with Formed Tab that Fits into Floor Structure to Prevent Turning
47DAJ	COVER, REAR DOOR INSIDE HANDLE Partial Coverage
47DYL	DOOR, ENTRANCE, FRONT Air, Outward Opening, with Single Pane Glass
47DAK	FASTENERS, REAR DOOR Bolts and Nutserts, Rear Door To Body
47DDE	HANDLE, ASSIST, ENTRANCE DOOR Outside Entrance

Vehicle Specifications
2025 CE SCHOOL BUS (PB110)

February 08, 2024

<u>Code</u>	<u>Description</u>
47DEY	HANDLE, EXTERIOR, REAR Emergency Door; Yellow
47DDH	HOLD BACK, REAR DOOR Stationary, No Cables, with Plastic Cover
47DDU	LATCH, REAR DOOR One Point Slide Bar, Cam Operated, with One Inch Stroke
47EYL	LOCK, ENTRANCE DOOR in External Release, with Key
47DEK	LOCK, REAR DOOR with Ignition Starter Interlock
47EHA	CARTON, SHIPPING Carton for Spare Wheel Only, Inside Bus
47BDJ	COMPARTMENT, DRIVER STORAGE Bin, Sized to Hold Three Ring Binder, Includes (1) USB-A Port and (1) USB-C Port
47EBM	HOLD DOWN, BATTERY For Up To 3 Batteries
47BMA	WASTE CONTAINER Removable, Located in Driver Area
47LAU	INSULATION, ROOF/SIDES/BULKHEAD 1.5"
47LAT	NOISE REDUCTION, ROOF BOW Conventional; Insulation, 31'2", 31'11", 32'8", 33'5", 34'2", 34'11", 35'8" Body Lengths
47MBA	UNDERCOAT, BODY Fire Resistant, Water Based, TT-C-730 Spec <u>Includes</u> : UNDERCOATING Performed Before and After Mounting on Chassis
47SPC	ALPHA/NUMERIC DECAL GUIDE Quantity 031-40
47AJA	BODY CERTIFICATION TAG Metal
47APJ	BODY RATING TAG Metal; for State of Texas, Includes Design Capacity and Seat Capacity
47AJC	BODY TAG, METAL Capacity to Include the Total Number of Passengers
47PLX	LETTERS, DEF, I.D. Decal; "DEF ONLY", 1" Black, on DEF Filler Door
47MJR	LETTERS, DOOR, REAR Decals; "EMERGENCY DOOR", 2" Black Letters Inside and Outside
47NGP	LETTERS, FUEL I.D. Paint; "DIESEL FUEL", 2" Black, Adjacent to Fuel Filler Door
47MVA	LETTERS, HEADER Decal; "WATCH YOUR STEP", 1" Black, Above Windshield
47MRU	LETTERS, E/E WINDOW, LEFT (2) Decal Sets, "EMERGENCY EXIT", Black Inside and Outside
47NHL	LETTERS, E/E WINDOW, RIGHT (2) Decal Sets, "EMERGENCY EXIT", Black, Inside and Outside
47MAV	LETTERS, SCHOOL BUS SIDE Decal; "SCHOOL BUS"; in 8" Reflective Black Letters, Each Side
47BKK	LETTERS, SCHOOL BUS FRONT/REAR Decal; "SCHOOL BUS"; with 8" Black Reflective Letters, 3M Fluorescent Diamond Grade, Yellow On Front and Rear Cap
47MVC	LETTERS, STEPWELL Decal, "WATCH YOUR STEP", 2.5" Black, Behind Door on Step Riser
47NTE	LOGO, ROOF LINE Decal; Wing and Shield, First Body Section, Above Driver Window and Entrance Door Over Driver Window and Entrance Door
47NMG	OPERATING INSTRUCTIONS, REAR Decal, Inside Rear Emergency Door
47NKM	PAINT COLOR, BODY INTERIOR 9384 Spring White
47NJA	PAINT COLOR, BODY EXTERIOR 4421 School Bus Yellow
47NJS	PAINT COLOR, BUMPER Rear, 0001 Canyon Black
47NJM	PAINT FLASHER BACKGRD 0001 Canyon Black

Vehicle Specifications
2025 CE SCHOOL BUS (PB110)

February 08, 2024

Code	Description
47NTY	PAINT HOOD AND FENDER To Match Body Exterior
47NKD	PAINT COLOR, ROOF 9219 Winter White, Beginning 5" Above Drip
47NKL	PAINT, RUB RAIL Flange to Flange
47NAB	PAINT COLOR, RUB RAILS 0001 Canyon Black
47NGW	SEAL, RUB RAILS Top Edge, All Rails
47MRN	STRIPING, E/E WINDOW, LEFT (02) Perimeter, 1" Yellow
47MUP	STRIPING, E/E WINDOW, RIGHT (02) Perimeter, 1" Yellow
47MSA	STRIPING, PERIMETER, REAR Emergency Door, 1" Yellow Reflective
47MVM	STRIPING, REAR END 1" Yellow
47MSJ	STRIPING, ROOF HATCH, FRONT Decal, Perimeter, 1" Yellow
47MSK	STRIPING, ROOF HATCH, REAR Decal, Perimeter, 1" Yellow
47MSS	STRIPING, SEATLINE 2" Yellow
47MTY	WIRING DIAGRAM Schematic, Electrical
	<u>Includes</u> : ACCESS PANEL for Wiring Diagram Schematic Located on Inside of Electrical Panel Door, Below Driver Window
47SBB	SUB FLOOR, PLYWOOD Conventional; B-B Marine Grade, Less Sealed Edges, 5/8", 5 Ply, for 31'2", 31'11", 32'8", 33'5", 34'2", 34'11", 35'8" Body Lengths
47KEJ	DISARM, POST TRIP INSPECTION Button Located on Light Bar at Rear of Bus
47KEB	MONITOR, POST TRIP INSPECTION {Leave No Student Behind} Accessory Controlled, with Push Button Alarm Disable at Rear of Bus Prompts Driver to Walk to Back of Bus to Disable Alarm
47DNK	SWITCH, LOCATION Steering Wheel; Includes Master Flasher, Flasher On/Off, Red Override, and Door Control
	<u>Includes</u> : SWITCH, STEERING WHEEL, LIGHT Includes Illuminated Switches

BODY FEATURES

48ANT	WINDOW, DRIVER Laminated, Clear
48BJA	COLOR, WINDOW FRAME, PASS Passenger Window, Natural Aluminum Finish
48BAH	WINDOW, E/E, LEFT (2) Vertical Hinge
48BKP	WINDOW, E/E, RIGHT (2) Vertical Hinge
48AUN	WINDOW, PASSENGER, TINT Conventional; 28% Light, Laminated Glass, 78" Headroom, with 31'2", 31'11", 32'8", 33'5", 34'2", 34'11", 35'8" Body Lengths
48ARU	WINDOW, SASH (20) 27" Sections, 9"x 23" Opening
48ASP	WINDOW, SASH +9 SECTIONS (2) 9" x 32 1/4" Opening
48APL	WINDOW, STOPS 12" Opening, Only with 78" Headroom
48PAY	AISLE POSITION Center, for balanced seating
48PBB	FLOOR COVERING, COLOR Black
48PJR	FLOOR COVERING, TRIM Aluminum

Vehicle Specifications
2025 CE SCHOOL BUS (PB110)

February 08, 2024

Code	Description
48PJZ	FLOOR COVERING, TYPE {Koroseal} All Body Lengths
48VVR	STEP TREADS {Koroseal} Pebble White Nosing Only, with Non-Metal Backing, used with Formed Treaded Steps
48PAV	WHEEL POCKET COVER Plastic, ABS
48PKC	HOSE CLAMPS, HEATER HOSE Constant Torque for Heater System
48UZK	FAN, DEFOG LEFT OF DRIVER 6.50" Diameter, Black, Mounted on Driver Overhead Compartment, 2 Speed Switch in Panel
48GNW	FAN, DEFOG RIGHT CENTER 6.50" Diameter, Black, Mounted Over Windshield, 6" Right of Centerline, 2 Speed Switch in Panel
48PPP	HEATER CUT OFF, VALVE INSIDE Brass Ball, Inside Driver Area
48PMJ	HEATER, PASS, LT REAR 84,500 BTU <u>Includes</u> : AIR FILTER
48PNW	HEATER, WATER PUMP {2 MPU 12} Self Priming, with Plastic Housing
48UZN	ROOF HATCH, FRONT {Specialty Hybrid Adv H1975-025-191-0F} Emergency Exit with Outside Release, Alarm, English Decals
48UZT	ROOF HATCH, REAR {Specialty Hybrid Adv H1975-025-191-0F} Emergency Exit with Outside Release, Alarm, English Decals
48PPS	ROOF VENT, FRONT Static
48PPC	SWITCH, HTR FAN, REAR, LT with 84,500 BTU Rear Heater Only
48TMY	SEAT, DRIVER {National 2000} Air Suspension Dual Shock, High Back with Integral Headrest, Isolated, with 2 Position Front Cushion Adjustment, 6 to 17 Degree Seat Back Adjustment, Mechanical Lumbar Support, Includes Additional Back Padding <u>Includes</u> : SEAT BELT, DRIVER Adjustable D-Loop Seat Belt, Single Locking Retractor
48PXP	UPHOLSTERY, BARRIER, TYPE (1-2) Prevaill, 42 oz.
48PVN	UPHOLSTERY, DRIVER SEAT, COLOR Drivers Seat, Gray
48PVA	UPHOLSTERY, DRIVER SEAT, STYLE Plain, with Cloth Insert
48PWR	UPHOLSTERY, DRIVER SEAT, TYPE Prevaill, 42 oz.
48BDS	BARRIER, CRASH, AFT ENTRY DOOR 39", 2 Leg
48RAL	BARRIER, CRASH, AFT DRIVER 39", 1 Leg
48UZX	HAND RAIL, ENTRANCE DOOR, AFT Dual Height Stainless Steel, Upper Rail 1.25" OD 28" Above Floor, Lower Rail 1" OD
48UZY	HAND RAIL, ENTRANCE DOOR, FWD Dual Height Stainless Steel, Upper Rail 1.25" OD 28" Above Floor, Lower Rail 1" OD
48RET	PANEL, MODESTY, AFT ENTR DOOR Mounted Under Barrier
48REP	PANEL, MODESTY, AFT OF DRIVER Mounted Under Barrier
48ACN	SEAT BELT, DRIVER, COLOR with Blaze Orange Seat Belt Webbing
48USV	SEAT BACK, PASSENGER High Back
48XGC	SEAT, 26", WALL, 3PT, LT {BTI Seating System} (01) High Back, with 3 Point Seat Belts

Vehicle Specifications
2025 CE SCHOOL BUS (PB110)

February 08, 2024

Code	Description
48YAG	SEAT,39",WALL,3PT,LT {BTI Seating System} (11) High Back, with 3 Point Seat Belts
48YAW	SEAT,39",WALL,3PT,RT {BTI Seating System} (12) High Back, with 3 Point Seat Belts
48PWD	UPHOLSTERY, PASS SEATS, COLOR Gray, for Seats, Barriers and Head Bumpers
48PHP	UPHOLSTERY, PASS SEATS, TYPE Prevaill, 42 oz.; for (23-24) Seats
48RLX	CUSHION, SEAT 15" Depth
48RRA	UPHOLSTERY, SEAT, STITCHING Single

BODY FEATURES

48HAC	WINDOW, ENTRANCE DOOR Laminated, Clear, with Single Piece Glass
49AMJ	ALARM, BACKING {Ecco #575} 107 dB
49AMT	CIRCUIT, PROTECTION Breakers, Manual Reset in Lieu of Fuses
49BCN	FLASHER SYSTEM (8) Warning Lights, 8-Lamp System, Electronic Relay Flasher, Non-Sequential Operation, Red Lights Activate with Door Open
49DBR	HOOD, WARNING LAMP (4) Black, 8-Lamp System, One Hood Above Two Lights
49JBU	LIGHT, ENTRY DOOR {Sound Off/OptiLuxx} LED; 4" Oval; Light Mounted in Skirt Behind Entrance Door, Wired To Step Light
49BCR	LIGHT, EXTERIOR, CHECK Automatically Activates Lights for Pre Trip Inspection
49ATV	LIGHT, INDIC, WARNING LIGHTS Red and Amber
	<u>Includes</u> : LIGHTS, WARNING Indicator Located in Instrument Cluster
49JBV	LIGHT, LICENSE PLATE {Sound Off/OptiLuxx} LED, with Mounting Gasket
49JBW	LIGHT, STEP {Sound Off/OptiLuxx} 4" Round LED, White, Wired to Clearance Lights, Operated by Entrance Door
49EYH	LIGHT, STROBE LED, Specialty Man. Co. 845-4020-100, Low Profile, Double Flash, 4.50" High
49ZNC	LIGHTS, BACK UP (2) {Sound Off/OptiLuxx} 4" Round, White, LED, with Flange
49JBS	LIGHTS, CLUSTER {Sound Off/OptiLuxx} Oval, 4 Internal LEDs per Light; Amber Front and Red Rear
49BYZ	LIGHTS, DIRECTIONAL, REAR (2) {Sound Off/OptiLuxx} LED, 7" Round Amber
49EAX	LIGHTS, DIRECTIONAL, SIDE (4) {Sound Off/OptiLuxx} Rectangular LED Armored, 2 Each Side First Section Aft Entrance Door & Forward Rear Wheel Pocket
49JER	LIGHTS, DOME LED, Rectangular Recessed Type, Stagger Mounted, for 34'02", 34'11", 35'08" Body Lengths
49ESC	LIGHTS, DOME, DRIVER (1) LED, Rectangular, Mounted in Light Bar in Ceiling, with Separate Switch
49JED	LIGHTS, MARKER, FRONT & REAR LED, Flush Mount, Amber Front and Red Rear
49ZNN	LIGHTS, MARKER, SIDE, INTERMED LED, Amber, Flush Mount, Intermediate, Centered, Required for Units 30 Foot or Longer
49BYT	LIGHTS, STOP (2) {Sound Off/OptiLuxx} and Tail; 7" Round LED, Red
49ZNG	LIGHTS, STOP & TAIL ADDITIONAL (2) {Sound Off/OptiLuxx} 4" Round LED, Red, with Flange
49NGJ	LIGHTS, WARNING (8) {Sound Off/OptiLuxx} (4) 7" Round Red Strobing LED and (4) 7" Round Amber Strobing LED, 2 Front, 2 Rear Each Color
49AWV	SPEAKERS AND WIRING (8) Flush Mounted In Light Bar

Vehicle Specifications
2025 CE SCHOOL BUS (PB110)

February 08, 2024

Code	Description
49ELC	STOP ARM, FRONT Electric, Composite Blade, 18" Octagon, Double Sided, 1/2" White Border, Hi Intensity Grade, Strobing LED Lights
49ELG	STOP ARM, LEFT REAR Electric, Composite Blade, 18" Octagon, Single Sided, 1/2" White Border, Hi Intensity Grade, Strobing LED Lights
49BSL	SWITCH, DOME LIGHTS, DIMMER for All Passenger Dome Lights
49SAA	SWITCH, INSTRUMENT PANEL LIGHTS; Rheostat
49EVL	SWITCH, NOISE SUPPRESSION Actuator Legend States, "NOISE SUPP ", for Separate Solenoid, with Red Switch in Panel
49AMY	SWITCH, REAR DOOR BUZZER for Emergency Door
49BXN	SWITCH, RED, OVERRIDE WARNING Wired Hot, with ESC, Mounted Left of Driver
49EGL	MIRROR, CROSS VIEW, EXTERIOR (2) {Rosco Mini Hawk-Eye} Black <u>Includes</u> : MIRROR MOUNT Attached to Body with Metal Backing Plates
49EGB	MIRROR, INSIDE 10" x 30", Clear
49DNB	MIRROR, REAR VIEW, EXTERIOR {Rosco AccuStyle} Black, Motorized Head, Heated, Breakaway Bracket
49ENK	VISOR, INTERIOR, LEFT FRONT 6" x 30", Transparent, For Left Windshield
49GDS	COMPARTMENT ABOVE DRIVER Left of the Driver <u>Includes</u> : COMPARTMENT ABOVE DRIVER Compartment Size: 39" x 10" x 10" : HINGES Piano Type
49JGJ	FIRE EXTINGUISHER 5 lb 3A-40BC Minimum, with Flexible Hose and Metal Nozzle
49JGN	FIRE EXTINGUISHER, FRONT LOC Located Behind Driver Seat
49GAY	KIT, BODY FLUID Texas
49EBA	KIT, FIRST AID Plastic; 24 Unit, Spec State
49MZV	LATCH, COMPARTMENT Locking, for Overhead Storage Compartment
49JEY	LOCATION, BODY FLUID KIT on Bulkhead
49GCH	LOCATION, FIRST AID KIT Right Side Front Bulkhead with Screws
49GDG	PADDING COMPART ABOVE DRIVER Window; Safety Equipment Compartment, with Cutout for Dome Light
49GLP	REFLECTORS, REAR (2) 3", Red, Mounted with Screws
49GLM	REFLECTORS, SIDE, FRONT (2) 3", Amber; 1 Aft Drivers Window Left, 1 Aft Entrance Door Right, Mounted with Screws
49GLA	REFLECTORS, SIDE, INTERMEDIATE (2) 3" Amber, 1 Each Side, Mounted with Screws, Below The Third Rub Rail From the Top
49GLG	REFLECTORS, SIDE, REAR (2) 3", Red, Mounted with Screws
49GED	SAFETY TRIANGLES Warning Reflectors, Mounted on Floor Between Driver Seat and Drivers Crash Barrier/ Stanchion/Partition
49GUB	CUTTER, SEAT BELT {TIE TECH Safecut} for Cutting Seat Belts
49JGE	CUTTER, SEAT BELT, LOCATION Mounted on Panel Left of Driver
49JAC	DEF FILLER DOOR with Non-Locking Latch

Vehicle Specifications
2025 CE SCHOOL BUS (PB110)

February 08, 2024

Code	Description
49MZS	FUEL FILLER DOOR Non-Locking, Lever Latch, Spring Loaded to Hold in Open Position
49CKT	FUEL FILLER PIPE Low Profile Neck Cap and Vent Hosing, for Use with Right Side Fill for Between the Rail Fuel Tanks, for Above the Floor Fuel Fill, for 25 GPM Fill Rate Only
49GUM	INSPECTION PLATE Fuel Sending Unit 8" x 8" Steel
49GVC	MUD FLAPS, REAR WHEELS (2) Rubber
49UBZ	STATE OF OPERATION Texas

Services Section:

WARRANTY

40126	WARRANTY Standard for CE, RE, BE School Bus Models, Effective with Vehicles Built March 1, 2017 or Later, CTS-3304H
40YET	SERVICES, TOWING {Navistar} Service Call to 24-Month/Unlimited Mileage to the Nearest IC Bus Dealer for Navistar Warrantable Failure as Contract Defined; Includes Engine Failure if Supplier Declines Tow Coverage & ESC Supplied thru Navistar; \$1100 (USA) Maximum Benefit per Incident
40YGC	SRV CONTRACT, EXT VEH COVERAGE {Navistar} To 24-Month/50,000 Miles (80,000 km), Covers 100% Parts and Labor; Includes Body; Excludes Extending Warranty for Engine, Transmission, Perforation or Corrosion of Cab/Cowl Structure and Paint

BODY FEATURES

49GVN	WARRANTY 5-Year, Limited
	SET GOVERNOR SPEED 55 MPH
	WEIGHT SLIP
	PRE DELIVERY INSPECTION CE MODEL
	STATE INSPECTION
	AC - 136KBTU BERGSTROM - FRONT & REAR INWALL W/MID EVAPS (FACTORY INSTALLED DASH AC) LHB INSTALL
	SEON 5 CAM SYS, GPS, WIFI, INSTALLED - LHB

Financial Summary
2025 CE SCHOOL BUS (PB110)

February 08, 2024

<u>Description</u>	<u>(US DOLLAR)</u>	<u>Price</u>
Net Sales Price:		\$1,434,790.00

Prices are good for 30 days from the date of this proposal.

PRICE PER BUS: \$143,479.00

PRICE FOR (10) TEN BUSES: \$1,434,790.00

This quote would be produced as a 2025MY product if awarded. Feature codes are subject to update upon IC Bus completion of code references. **Estimated delivery: 300-365 Days from receipt of a purchase order.** Longhorn Bus Sales will not be held responsible for material shortages or delays due to the global COVID-19 pandemic or any other reasons outside of our control, that of the represented OEM (IC Corp) or third-party vendors used to complete a customers' bus order. Any buses ordered, will be subject to any and all applicable surcharges at the time of build, due to the volatility of the producers material costs. Any applicable surcharges will be the responsibility of the buyer. A bus order may be delivered without OEM or third-party products (i.e., A/C, GPS, two-way radios, camera surveillance equipment, etc.), and any such items will be installed immediately upon availability. These shortages/delays will not hold up invoicing and or payment. Instructions for payment of invoices will be provided upon invoicing. No one from Longhorn Bus Sales will ever contact or email wiring or ACH instructions for payment. Due to industry constraints, quote pricing may fluctuate.

Price does not include Buy Board fee of \$800 per purchase order, please add if applicable. Buy Board contract 722-23.

40YGC Warranty: Longhorn Bus Sales will cover the warranty for 24-months/unlimited mileage. (Navistar will cover the first 50K miles. Longhorn Bus will cover 50K+ miles, up to the ending of the 24-month period, as per current Texas School Bus Specifications.

CODE "49GVN WARRANTY 5-YEAR, LIMITED" IS A NAVISTAR WARRANTY ONLY, IT DOES NOT APPLY TO ANY AFTERMARKET PARTS

By signing this document in acceptance of an order, the customer acknowledges that all equipment listed within this document is correct. Longhorn Bus Sales will not be responsible for any miss-built units. Any changes to what is listed herein, may result in additional charges to the order. Thank you.

Approved by Seller:

Accepted by Purchaser:

LHB Sales 02/08/2024

Official Title and Date

Frederick A. Hoke, Jr.
Authorized Signature

Firm or Business Name

Authorized Signature and Date

This proposal is not binding upon the seller without Seller's Authorized Signature

Official Title and Date

The TOPS FET calculation is an estimate for reference purposes only. The seller or retailer is responsible for calculating and reporting/paying appropriate FET to the IRS.

The limited warranties applicable to the vehicles described herein are Navistar, Inc.'s standard printed warranties which are incorporated herein by reference and to which you have been provided a copy and hereby agree to their terms and conditions.

BODY PLAN

WHEELBASE 276"

PB11000, 34 FT. 11 IN., PLUS 9 RR, CAP 71

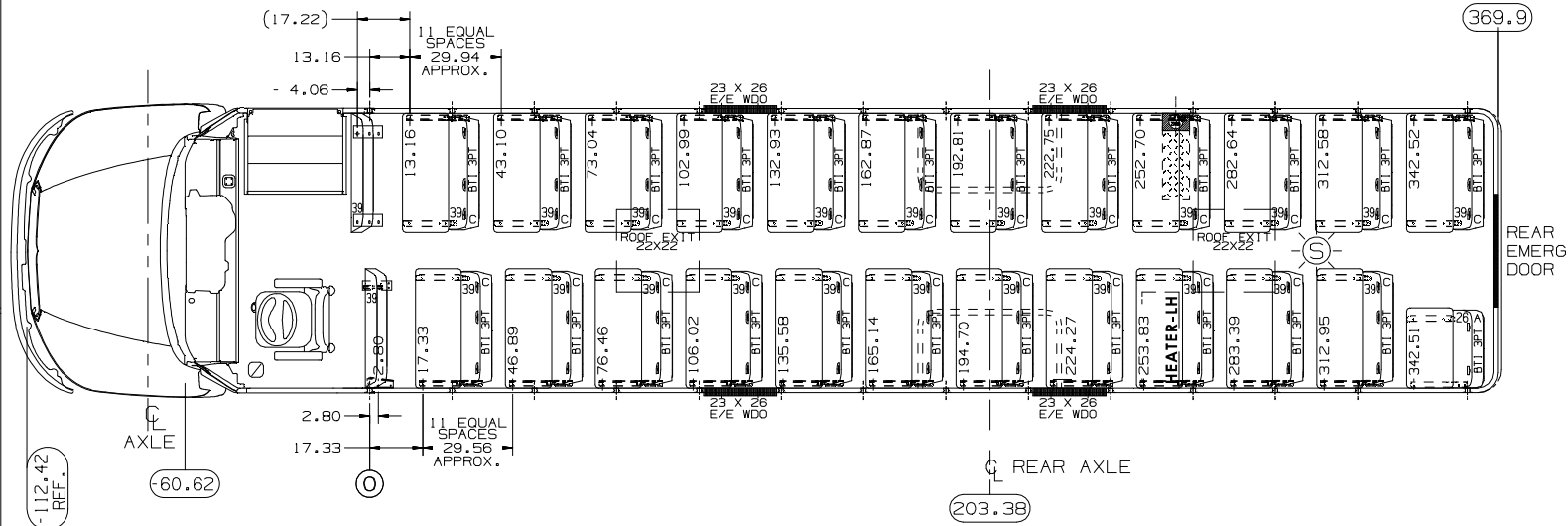

50ZDN/49001			INTERNATIONAL TRUCK AND ENGINE CORPORATION	
	INTERNATIONAL [®] CONFIDENTIAL PROPRIETARY			
	REFERENCE: DX9714A001		APPROX. MASS (WEIGHT)	
	LINEAR MEASURE: <input type="checkbox"/> mm <input checked="" type="checkbox"/> in		ROUGH PART	
	UNLESS SPECIFIED DIM TOLERANCES ARE FINISH PART			
	ONE PLACE 1.,X1	+1.5	-0.06	
	TWO PLACE 1.,XX1	+0.18	+0.03	
	THREE PLACE 1.,XXX1	+0.25	+0.10	
	ANGLES		+1°	INTERNAL CONTROL
	NAME: BODY PLAN PB11000		CONTROL: E 50	
NAME (TRANSLATION):		VERSION: E		
DRWN: U02A559	MATERIAL:	APPROVE:		
DATE: 23AUG22		DATE:		
DATE:		DATE:		
APPROVED:	PTR NDR CODE:	PART TYPE CODE:	SCALE: NONE	
DATE:			SIZE: 4	
RELEASE NO.:	PART NO.:	SHEET: 01		
	DM0092A001	FRAME: 167		

THIS UNIT CONFORMS TO APPLICABLE FMVSS

THIS DOCUMENT IS IN ACCORDANCE WITH ASME Y14.5M-1994 AS AMENDED BY THE INTERNATIONAL TRUCK DIVISION DIMENSIONING AND TOLERANCING ADDENDUM-2000.

Request for Taxpayer Identification Number and Certification

**Give Form to the
requester. Do not
send to the IRS.**

▶ Go to www.irs.gov/FormW9 for instructions and the latest information.

Print or type.
See Specific Instructions on page 3.

<p>1 Name (as shown on your income tax return). Name is required on this line; do not leave this line blank.</p> <p>LONGHORN BUS SALES, LLC</p> <p>2 Business name/disregarded entity name, if different from above</p> <p>3 Check appropriate box for federal tax classification of the person whose name is entered on line 1. Check only one of the following seven boxes.</p> <p> <input type="checkbox"/> Individual/sole proprietor or single-member LLC <input type="checkbox"/> C Corporation <input type="checkbox"/> S Corporation <input type="checkbox"/> Partnership <input type="checkbox"/> Trust/estate </p> <p> <input checked="" type="checkbox"/> Limited liability company. Enter the tax classification (C=C corporation, S=S corporation, P=Partnership) ▶ C </p> <p>Note: Check the appropriate box in the line above for the tax classification of the single-member owner. Do not check LLC if the LLC is classified as a single-member LLC that is disregarded from the owner unless the owner of the LLC is another LLC that is not disregarded from the owner for U.S. federal tax purposes. Otherwise, a single-member LLC that is disregarded from the owner should check the appropriate box for the tax classification of its owner.</p> <p><input type="checkbox"/> Other (see instructions) ▶</p>	<p>4 Exemptions (codes apply only to certain entities, not individuals; see instructions on page 3):</p> <p>Exempt payee code (if any) _____</p> <p>Exemption from FATCA reporting code (if any) _____</p> <p><small>(Applies to accounts maintained outside the U.S.)</small></p>
<p>5 Address (number, street, and apt. or suite no.) See instructions.</p> <p>9100 NORTH LOOP EAST</p> <p>6 City, state, and ZIP code</p> <p>HOUSTON, TEXAS 77029</p> <p>7 List account number(s) here (optional)</p>	<p>Requester's name and address (optional)</p>

Part I Taxpayer Identification Number (TIN)

Enter your TIN in the appropriate box. The TIN provided must match the name given on line 1 to avoid backup withholding. For individuals, this is generally your social security number (SSN). However, for a resident alien, sole proprietor, or disregarded entity, see the instructions for Part I, later. For other entities, it is your employer identification number (EIN). If you do not have a number, see *How to get a TIN*, later.

Note: If the account is in more than one name, see the instructions for line 1. Also see *What Name and Number To Give the Requester* for guidelines on whose number to enter.

Social security number									
or									
Employer identification number									
2	0	-	0	5	3	8	1	3	6

Part II Certification

Under penalties of perjury, I certify that:

- The number shown on this form is my correct taxpayer identification number (or I am waiting for a number to be issued to me); and
- I am not subject to backup withholding because: (a) I am exempt from backup withholding, or (b) I have not been notified by the Internal Revenue Service (IRS) that I am subject to backup withholding as a result of a failure to report all interest or dividends, or (c) the IRS has notified me that I am no longer subject to backup withholding; and
- I am a U.S. citizen or other U.S. person (defined below); and
- The FATCA code(s) entered on this form (if any) indicating that I am exempt from FATCA reporting is correct.

Certification instructions. You must cross out item 2 above if you have been notified by the IRS that you are currently subject to backup withholding because you have failed to report all interest and dividends on your tax return. For real estate transactions, item 2 does not apply. For mortgage interest paid, acquisition or abandonment of secured property, cancellation of debt, contributions to an individual retirement arrangement (IRA), and generally, payments other than interest and dividends, you are not required to sign the certification, but you must provide your correct TIN. See the instructions for Part II, later.

Sign Here	Signature of U.S. person ▶ <i>Ashley Schrader</i>	Date ▶ <i>01/05/2024</i>
------------------	---	--------------------------

General Instructions

Section references are to the Internal Revenue Code unless otherwise noted.

Future developments. For the latest information about developments related to Form W-9 and its instructions, such as legislation enacted after they were published, go to www.irs.gov/FormW9.

Purpose of Form

An individual or entity (Form W-9 requester) who is required to file an information return with the IRS must obtain your correct taxpayer identification number (TIN) which may be your social security number (SSN), individual taxpayer identification number (ITIN), adoption taxpayer identification number (ATIN), or employer identification number (EIN), to report on an information return the amount paid to you, or other amount reportable on an information return. Examples of information returns include, but are not limited to, the following.

- Form 1099-DIV (dividends, including those from stocks or mutual funds)
- Form 1099-MISC (various types of income, prizes, awards, or gross proceeds)
- Form 1099-B (stock or mutual fund sales and certain other transactions by brokers)
- Form 1099-S (proceeds from real estate transactions)
- Form 1099-K (merchant card and third party network transactions)
- Form 1098 (home mortgage interest), 1098-E (student loan interest), 1098-T (tuition)
- Form 1099-C (canceled debt)
- Form 1099-A (acquisition or abandonment of secured property)

Use Form W-9 only if you are a U.S. person (including a resident alien), to provide your correct TIN.

If you do not return Form W-9 to the requester with a TIN, you might be subject to backup withholding. See What is backup withholding, later.



OBTAINING SERVICE

Return this vehicle to any IC Bus Dealer authorized to service this model vehicle and engine.

DISCLAIMER

NO WARRANTIES ARE GIVEN BEYOND THOSE DESCRIBED HEREIN. THIS WARRANTY IS IN LIEU OF ALL OTHER WARRANTIES, EXPRESSED OR IMPLIED. THE COMPANY SPECIFICALLY DISCLAIMS WARRANTIES OF MERCHANTABILITY AND FITNESS FOR A PARTICULAR PURPOSE, ALL OTHER REPRESENTATIONS TO THE USER/PURCHASER, AND ALL OTHER OBLIGATIONS OR LIABILITIES. THE COMPANY FURTHER EXCLUDES LIABILITY FOR INCIDENTAL AND CONSEQUENTIAL DAMAGES, ON THE PART OF THE COMPANY OR SELLER. No person is authorized to give any other warranties or to assume any liabilities on the Company's behalf unless made or assumed in writing by the Company; and no other person is authorized to give any warranties or to assume any liabilities on the seller's behalf unless made or assumed in writing by the seller.

Remedies Under State or Provincial Law: Any suit for breach of this Limited Warranty must be initiated within one year after breach. Some States and Provinces do not allow the exclusion or limitation of incidental or consequential damages, so the above limitation or exclusion may not apply to the owner. This warranty gives the owner specific legal rights, and he may also have other legal rights which may vary by state or province.

RECORD OF OWNERSHIP

Upon receipt of new vehicle by original owner, complete the following:
I have read this Warranty Brochure and fully understand the warranty coverage, and the limitations and exclusions. I acknowledge that I have received a copy of the Owner's Limited Warranty and I accept the terms described herein.

_____	_____
Customer Signature	Date
_____	_____
Owner's Address	City State/Prov Postal Code
_____	_____
Bus Model	Vehicle Identification Number
_____	_____
Engine Number	Engine Serial Number
_____	_____
Date Delivered to User (DTU)	Odometer Reading at Delivery

IMPORTANT: The information contained in this Warranty Policy explains the coverage provided on your new IC Bus™ brand vehicle. This policy should be kept in the vehicle for presentation to the Dealer when you request warranty services.

Any provisions of this Limited Warranty that are prohibited or not enforceable in any jurisdiction shall be, as to such jurisdiction, ineffective to the extent of such prohibition or non-enforceability without invalidating the remaining provisions hereof, and any such prohibition or non-enforceability in any jurisdiction shall not invalidate or render non-enforceable any such provisions in any other jurisdiction.

All claims under this Limited Warranty must be submitted in writing to an authorized IC Bus dealer within the warranty period as stated herein. If you have questions regarding this Limited Warranty, contact IC Bus, LLC dealer. To locate nearest dealer, visit the IC Bus website www.ICBus.com.

EFFECTIVE WITH VEHICLES BUILT MARCH 01, 2017 OR LATER

LIMITED WARRANTY FOR SCHOOL BUS MODELS

CE Series (PB105), RE Series (PB305), BE Series (PB405)

IC Bus, LLC warrants to the original purchaser (the "Purchaser") that IC Bus, LLC brand buses and component parts thereof are, at the time of purchase, free from defects in material and workmanship and will remain free from such defects under normal use after delivery to the Purchaser as provided herein. Warranty shall begin at the time of delivery unless otherwise approved by IC Bus, LLC. The delivery limitations as set forth herein shall run from the date of delivery to the Purchaser in the United States of America and Canada. The remedy available under this Limited Warranty is non-cumulative in nature and is limited to repair or replacement at IC Bus, LLC option of the bus or component parts thereof that are returned to locations approved by IC Bus, LLC transportation charges prepaid, and which IC Bus, LLC examination disclosed to its satisfaction to be defective. IC Bus, LLC, at its option, will repair or replace any part of this vehicle which proves defective in material and/or workmanship in normal use and service, with new or ReNEWed parts. Exceptions are listed below under *What Is Not Covered*.

This warranty is automatically transferred to subsequent owners at no charge. Visit your local IC Bus Dealer for name and address change information.

COMPONENT COVERAGE

The components described below are given additional warranty coverage of variable time periods and distance traveled limitations, as shown in the *Warranty Coverage Schedule*.

1. Frame Rails and Crossmembers
2. Body/Cowl Structure
 - Body Structure defined as the steel body frame (which includes the roof, metal floor, sides and front and rear sections only).
 - As to items not considered Body Structure include but are not limited to the following: doors, corner moldings, inner ABS panels, interior wall, plywood, floor covering, windows, and trim moldings.
3. The Body/Cowl is warranted against perforation due to corrosion, except for perforation caused by industrial chemicals and/or corrosion caused by use in a corrosive industrial environment.
4. Navistar Diesel Engine Coverage Includes: Navistar Diesel Engine block, cylinder heads, internally lubricated components fuel pump, high pressure pump, turbocharger, water pump, air compressor, injectors/nozzles; electronic engine modules, engine relays, engine sensors and regulators required for electronic engine operation, and certain aftertreatment components. Excluding: attaching accessories (e.g., fan clutch, alternator, starter, etc.), and externally mounted electrical and filtration systems.
5. Power Solutions International 8.8L Propane and Gas Engine Coverage Includes: Engine block, cylinder heads, internally lubricated components, water pump, air compressor, injectors/nozzles, fuel system components; electronic engine modules, engine relays, engine sensors and regulators required for electronic engine operation, exhaust catalyst. Excluding: attaching accessories (e.g., fan clutch, alternator, starter, etc.)
6. Spicer front & rear axles and propeller shaft, when used with Allison transmission; excluding brakes, wheel ends axle shafts, controls & attachments.

THE PROVISIONS HEREOF CONSTITUTE THE EXCLUSIVE AND COMPLETE WARRANTY BY IC BUS, LLC ON IC BUS™ BRAND BUSES AND COMPONENT PARTS THEREOF MANUFACTURED BY IT, OR APPROVED BUS BODY CONTRACT MANUFACTURERS AND IS IN LIEU OF ALL OTHER OBLIGATIONS OR LIABILITIES OF IC BUS, LLC WHETHER EXPRESS OR IMPLIED.

Note: The customer has 365 days and up to a maximum of 100,000 miles (160,000 km) from DTU (delivery to end user) to purchase an extended warranty on the unit. For extended warranty purchases between 181 and 365 days from DTU and <100,000 miles (160,000 km) an additional fee will be assessed. See your local IC Bus dealer for details.



Items Covered	Months	Miles/Km (000)
BASIC VEHICLE COVERAGE		
Basic Vehicle Warranty	12	Unlimited
Towing (Chassis related issues)	3	Unlimited
Towing (Vehicles with Navistar built engine failures only)	24	Unlimited
Towing (Vehicles with Power Solutions International, Inc. 8.8L Propane engine failures only)	60	Unlimited
Towing (Vehicles with Power Solutions International, Inc. 8.8L Gasoline engine failures only)	60	Unlimited
COMPONENTS		
Frame Rails and Crossmembers	60	Unlimited
Body/Cowl Structure (Roof, Metal Floor, Sides and Front and Rear Sections)	60	Unlimited
Body/Cowl Perforation Corrosion	60	Unlimited
Bumper Corrosion and Paint Delamination	36	Unlimited
Body/Cowl/Hood Paint Delamination	60	Unlimited
Brightwork, Chassis Paint and Corrosion	6	Unlimited
IC Bus, LLC Factory Installed Air-Conditioning (IC Air)	30	Unlimited
SEATS***IC Bus manufactured Seats Only		
Foam	48	50/80
Upholstery	24	24/40
Frame and Barriers	60	Unlimited
ENGINE*		
Power Solutions International, Inc. 8.8L Propane Engine	60	Unlimited
Power Solutions International, Inc. 8.8L Gasoline Engine	60	Unlimited
DRIVETRAIN**		
Eaton Precision Transmission	12	Unlimited
Spicer - 3 Part Dana Drivetrain (Front & Rear Axles, Propeller Shaft, When Used With Allison Transmission Only)	48	50/80
Meritor Axles	48	75/120

WHAT IS NOT COVERED

AFTER THE FIRST 90 DAYS FROM DELIVERY TO USER (DTU):

- Correction of loose fasteners, squeaks, rattles and unusual noises.
- Towing (vehicles with non-engine failures only)
- Adjustments (e.g., headlights, brake/clutch adjustments, steering system adjustments, coolant levels, doors).

COMPONENTS / ITEMS:

- Warranted by their respective manufacturers (e.g., non Navistar brand engines, tires & tubes, Allison Transmissions, Hybrid electric, lubricants, etc.)
- Bodies, equipment and accessories installed by other than authorized IC Bus employees at IC Bus manufacturing plants.
- Front and rear axle alignment.
- Front & Rear axle coverage excludes brakes, wheel ends, axle shafts, controls & attachments.

REPAIRS:

- Maintenance-related items/repairs or those as a result of normal wear and tear, including tune-ups, brake/clutch lining, windshield wiper blades, tire balancing, lubrication and other similar procedures/parts required to keep vehicle in good working condition.
- To any part of the vehicle subjected to misuse, negligence, improper maintenance, improper operation, or which is the result of an accident.
- Fade, runs, mismatch or damage to paint, trim items, upholstery, chrome, polished surfaces, etc., resulting from environmental causes, improper polishes, cleaners or washing solutions, or chemical and industrial fallout.
- In which power train, propeller shaft and suspension sales guidelines (specifications) are not strictly adhered to by all owners and operators of this vehicle.

OTHER:

- Vehicles sold and/or operated outside the United States and Canada.
- Vehicles/components that have had unauthorized alterations or modifications.
- Vehicles on which the odometer reading has been altered.
- Loss of time or use of the vehicle, loss of profits, inconvenience, or other consequential or incidental damages or expenses.
- Replacement of defective parts with parts other than those provided by IC Bus, LLC.

This warranty does not apply, or include coverage for defects attributable to the following:

- (a) Damage resulting from: (i) misuse, abuse, accident, neglect, negligence, vandalism, fire, riot, war, or Acts of God;
- (b) (ii) Structural or other modifications or alteration without prior express written authorization by IC Bus, LLC; (iii) Repair or attempted repair by unauthorized persons; (iv) Replacement of original components with substitutes without prior express written authorization by IC Bus, LLC; (v) Failure to perform routine preventative maintenance as customarily accepted within the industry or failure to provide proof of such preventative maintenance having been performed; (vi) Exposure to corrosives, contaminants, chemicals, salt, irradiation or atmospheric or environmental conditions; (vii) Usage or loading in excess of recommended capacities or in non-standard applications, including off-road.
- (c) Fading or discoloration of paint, lettering or decals.
- (d) Effects of aftermarket installation and aftermarket parts installed by the dealer or customer.

*Emission Coverage: Refer to engine operator's manual for emission coverage.

**Drivetrain:

- Allison Transmissions products or Transynd lubricants and fluids are not covered under this warranty. For warranty information see: www.allisontransmission.com/publications/
- For specific Eaton/Fuller Warranty coverage, see supplier information: www.roadrangerwarranty.com
- For extended component warranty: www.roadranger.com/Roadranger/warranty/Extended_Warranty/index.htm

***For non IC Bus Manufactured seats, contact the seat supplier for their warranty coverage. For Enova charge sustaining and charge depleting standard warranty to: <http://enovasystems.com/customer-support.html>

*1/24/2019 removed MaxxForce Engines from coverage as Buses built post March,1,2017 no longer offered this engine.



Revised 4/1/2019

Telematics Data Disclosure

Your Navistar vehicle may include an activated telematics subscription service. By accepting this Limited Warranty you consent to our collection and use of data from your vehicle as set forth at www.oncommandconnection.com on behalf of yourself and any vehicle operators and passengers. Navistar, Inc. or its affiliates will collect and send diagnostic and system data from your vehicle and use it for various purposes as further set forth in our Privacy Policy, posted at www.oncommandconnection.com, such as improving the uptime for your vehicle, improving our vehicles in the future, and reducing warranty events. If you choose not to allow Navistar to access your data, you may suspend your subscription at www.InternationalTrucks.com/Opt-Out

**RE/CE BUS EXTENDED VEHICLE COVERAGE
INCLUDING BUS BODY**

This **Extended Vehicle Coverage Including Bus Body option(s)** provides coverage for time or distance traveled from new vehicle delivery date, whichever expiration occurs first.

During the period selected, Navistar, Inc. will repair or replace any of the covered components as defined below which proven defective in material and/or workmanship in normal use, with new or ReNEWed parts. Exceptions are listed herein under *What is Not Covered*.

GROUP 01 - FRAME AND BUMPER

- | | | |
|---------------------------|--------------------------------|--------------------------------|
| 067 - Carrier, Tire | 306 - Outtrigger, Bus Platform | 581 - Bumper Frame |
| 071 - Bumper | Mounting | 660 - Rail, Frame Side |
| 211 - Bracket or Mounting | 307 - Crossmember | 739 - Reinforcement or Gussets |
| | 309 - Crossmember, Engine | |

GROUP 02 - FRONT AXLE

- | | | |
|--------------------------|-------------------------|--------------------------|
| 016 - Arm, Steering | 353 - Fitting/Zerk | 667 - King Pin & Bushing |
| 032 - I-Beam, Front Axle | 535 - Knuckle, Steering | 799 - Seal, King Pin |

GROUP 03 - SUSPENSION

- | | | |
|--|--|------------------------------------|
| 062 - Equalizer / Rocker Arm and Bushing | 264 - Control (Air Suspension Only) | 468 - Spring Leaf Assembly |
| 066 - Torque Arm & Bushing Assembly | 341 - Bracket, Shock Absorber Mounting | 584 - Bracket Assembly, Spring |
| 074 - Walking Beam & Bushing Assembly | 406 - Bolt, Center | 646 - Shackles, Pins & Bushing |
| 203 - Air Bag Assembly | 437 - Suspension Air Control Manifold Assembly | 711 - Crossmember, Rear Suspension |
| | 438 - Suspension, ECM | 769 - Sway Bar Assembly |
| | | 804 - Stop, Axle |

GROUP 04 - BRAKES

- | | | |
|--|---|--|
| 003 - Tank, Air, Vacuum | 429 - Cable/Linkage, Parking Brake | 811 - Relay/Magnetic Switch |
| 005 - Knob | 461 - Linkage / Cam / Camshaft, Wheel Brake Actuating | 812 - Valve, Modulator |
| 007 - Pumps | 462 - Linkage/Pedal/Spring Brake Actuating | 816 - Sender, Wheel |
| 009 - Accumulators | 511 - Power Assist Unit | 826 - Caliper |
| 010 - Hydraulic Power Brake (HPB) Unit | 617 - Backing Plate/Anchor/Dust Shield | 840 - Caliper Bracket |
| 012 - Solenoid Valve | 634 - Pump, Back-Up (Less Motor) | 842 - Switch, Flow |
| 013 - Adjuster, Slack | 636 - Motor, Back-Up | 846 - Switch, Back-Up Motor |
| 020 - Cylinder, Self Actuate Hydraulic Release | 643 - End Cover, Unloader Valve Air Dryer | 847 - Switch, Pressure Differential |
| 036 - Adjuster Assembly, Automatic | 662 - Spring, Brake Shoe Return | 848 - Module, Monitor |
| 105 - Bracket, Brake Chamber | 747 - Spring Applied Air Release (Saar) Canister | 851 - Valve, Spring Brake Control |
| 231 - Chamber | 751 - Sensor, Steering Angle | 852 - Brake Assembly, Drive Line |
| 232 - Diaphragm, Chamber | 753 - Sender, Stability Control | 909 - Harness, Cab |
| 255 - Cylinder, Master | 801 - Control Unit, Electronic ECU | 913 - Valve, Foot Control or Pedal |
| 390 - Reservoir | | 920 - Valve, Hand Control |
| 392 - Switch, Fluid Level | | 923 - Harness, Front End (Wires/Connectors/Term) |
| 397 - Governor and Mounting, Air | | 932 - Valve, Front Wheel Limiting & Mounting |

940 - Harness, PDM
Distribution

GROUP 05 - STEERING

018 - Arm, Pitman
069 - Link, Drag
164 - Column Assy. &
Mounting, Steering
167 - Wheel Mechanism, Tilt
Steering
206 - Couplings/U-Joint,
Steering Shaft

GROUP 06 - PROP SHAFT

101 - Bearing
165 - Mounting, Bearing

GROUP 07 - EXHAUST

107 - Assembly, Basic
143 - Bracket/Support,
Mounting
426 - Guard / Heat Shield

GROUP 08 - ELECTRICAL

005 - Knob
018 - Alternator Assembly
038 - Multiplex Signal Module
(MSM)
041 - Telematics Control
Module (TCM)
049 - Switch, SOS
059 - Regulator, Voltage
063 - Solenoid Base, Pneumatic
Accessory
065 - Solenoid Unit, Pneumatic
Accessory
073 - Amplifier, Pyrometer
074 - Gauge, Voltmeter
076 - Gauge, Fuel Level
088 - Gauge, Oil Pressure
(Electrical)
097 - Gauge, Coolant
Temperature (Electrical)
099 - Gauge, Ammeter
109 - Gauge, Engine Oil
Temperature
110 - Gauge, Pyrometer
111 - Gauge, Rear Axle Oil
Temperature
116 - Gauge, Speedometer
(Electrical)
117 - Gauge, Tachometer
(Electrical)
118 - Gauge, Transmission Oil
Temperature
124 - Sender, Fuel Level

944 - Valve, Quick Release
955 - Pully

252 - Wheel, Steering
311 - Gear Assembly, Steering
314 - Gasket, Power Steering
Pump Mounting
316 - Wheel Mechanism,
Telescoping Steering
370 - Bracket/Mounting,
Steering Gear

391 - Joint, Universal
475 - Boot / Clamp, Slip Joint

533 - Tail Pipe, Exhaust Gas
Cooler
551 - Pipe, Crossover
576 - Pipe & Flange, Exhaust

127 - Tachometer/Trip Recorder
(Elec Driven)
155 - Sender, Pyrometer
156 - Sender, Rear Axle Oil
Temperature
159 - Sender, Transmission Oil
Temperature
202 - Motor, Starter
217 - Solenoid, Starter Motor
221 - Bezel/Cover Plate
223 - Circuit Board
224 - Switch, Speedometer /
Tachometer Dip
(Reprogramming Only)
225 - Panel, Circuit
Breaker/Relay/Fuse
226 - Mounting, Circuit
Breaker/Relay/Fuse Panel
251 - Harness, Coiled Ribbon
(Clock Spring)
266 - Switch, Clutch
269 - Module, Coolant Probe
270 - Probe, Coolant Level
284 - Antenna and Lead-In
347 - Mounting
372 - Module, Pyrometer
373 - Module, Ammeter
374 - Circuit Housing,
Speedometer / Tachometer
375 - Sender, Air Pressure
388 - Lamp Assembly

990 - Wiring

555 - Cylinder Assembly &
Valves
653 - Cooler Assembly, Oil
701 - Pump Assembly
757 - Reservoir Assembly
818 - Valve, Control
955 - Pulley

478 - Shaft
703 - Yoke/Spline

615 - Pipe/Stack, Tail
775 - Cap, Stack
824 - Pipe, Flex

401 - Clean Power Cable
(Battery To Cab)
404 - Flasher
405 - Beeper, Hydraulic Brake
Warning
407 - Alarm, High Water
Temp/Low Oil Press.
408 - Beeper, Low Air Pressure
418 - Regulator & Motor
Assembly
424 - Hourmeter
430 - Odometer
487 - Horn Assembly
499 - Contact Ring/Button, Horn
508 - Monitor, Driver Display
Unit
510 - Sensor, Radar Side/Front
511 - Camera, Forward Looking
512 - Display, Side Sensor
514 - Sensor, Turn Assembly
516 - Magnet, Turn Sensor
Assembly
518 - Harness, Side Sensor
585 - Automatic Headlight
Sensor
586 - Antenna, Tire Pressure
Monitor
587 - Brake Stroke Chamber
W/Sensor
588 - Display, Vehicle
Information

589 - Fuel Filter Restriction
Globe W/Sensor
595 - Module/Controller, Tire
Pressure Monitor
596 - Module, Vehicle Sensor
598 - Batteries, Jumper Cable
599 - Sensor, Brake Pad Wear
601 - Wheel Module, Tire
Pressure Monitor
607 - Switch, Air Horn
608 - Clock
609 - Switch, Cruise On/Off
618 - Switch, Cruise Set/Reset
620 - Switch, Engine Brake
On/Off
621 - Switch, Headlight
Interrupt
623 - Switch, Marker Interrupt
624 - Switch, Radio
628 - Switch, Transmission
Mode
629 - Switch, Transmission Shift
637 - Alarm, Back-Up

GROUP 09 - COOLING

012 - Solenoid Valves
022 - Core
026 - Shutter Assembly
047 - Hose/Pipe, Radiator
064 - Tank & Neck, Radiator
083 - Shroud Clamp
085 - Shroud Mounting Bracket
091 - Shroud, Engine Mounted
108 - Cylinder Assembly,
Actuating
123 - Mounting, Radiator
136 - Motor
142 - Rod Assembly, Control

GROUP 10 - INSTRUMENTS

053 - Head Assembly

GROUP 11 - CLUTCH

059 - Bearing and Sleeve
Assembly, Release
101 - Cylinder, Master
133 - Cylinder, Slave

GROUP 12 - ENGINE

222 - Solenoid
740 - Blade Assembly, Fan
744 - Fan Drive, Viscous
746 - Fan Drive, On/Off
748 - Control, Fan Clutch
750 - Pulley, Fan
802 - Sart Module

705 - Solenoid, Air
718 - Solenoid
743 - Clean Power Cable (Batt
to Engine Connect
745 - Daytime Running Light
Switch
758 - Central Processing Unit
(CPU)
783 - Compass, Electronic
784 - Thermometer, Electronic
797 - Clean Power Cable (Batt
to Transmission)
811 - Relay/Magnetic Switch
815 - Switch, Key/Ignition
821 - Switch, Push Button
Starter
828 - Switch, Dimmer
835 - Switch, Back-Up Light
840 - Switch, Neutral Start
848 - Module Monitor
850 - Switch, Low Oil Pressure
854 - Controller, Esc
863 - Switch, Stoplight (Air)

176 - Shroud
197 - Shutterstat
210 - Glass, Sight
211 - Tank & Mounting, Surge
222 - Solenoid
240 - Motor / Pump
427 - Bottle and Hose, Coolant
Recovery
504 - Fan Module
616 - Cooler, In Tank Oil
701 - Pump Assembly
740 - Blade Assembly, Fan
755 - Electronic Fan Controller

292 - Fork and Cross Shaft,
Clutch Release
349 - Lever Assembly, Relay
403 - External Linkage

811 - Relay/Magnetic Switch
814 - Pedal Assembly,
Accelerator
828 - Front Mount/Bolt
836 - Rear Mount/Bolt
865 - Switch, Temperature

864 - Switch, Stoplight
(Hydraulic)
865 - Switch, High Water
Temperature
870 - Switch, Low Air Pressure
871 - Switch, Low Coolant
Level
872 - Switch, Parking Brake
884 - Switch, Headlight
885 - Switch, Marker/Interrupt
886 - Switch, Turn Signal
887 - Programming
907 - Actuator, Switch Pack
908 - Switch Pack (Base)
909 - Harness, Cab Wires
Conn's & Terminals
923 - Harness, Front End
(Wires, Connectors And
940 - Harness, PDM
Distribution
955 - Pulley
996 - Monitor, Battery Run
Down Protection

756 - Hydraulic Fluid Reservoir
767 - Oil Cooler (Oil-To-Air)
811 - Relay/Magnetic Switch
852 - Pipe, Charge Air Cooler
865 - Switch, Temperature
909 - Harness, Cab
(Wires/Connectors/Term)
925 - Charge Air Cooler,
Chassis Mounted
940 - Harness, PDM
Distribution

440 - Self Adjusting Mechanism
462 - Pedal
639 - Intermediate Plat
862 - Plate Assembly, Pressure

905 - Bracket, Air Compressor
Mtg.
909 - Harness, Cab
(Wires/Connectors/Term)
911 - Bracket, Alternator Mtg.
914 - Bracket, Refrigerant
Compressor Mounting

919 - Bracket, Power Steering
Pump Mounting
930 - Coupling, Accessory
Drive

GROUP 13 - TRANSMISSION

114 - Case
125 - Flange, Companion
138 - Block, Resistor
139 - Housing, Bell
191 - Retainer, Bearing
313 - Detent Poppet Ball &
Spring

GROUP 14 - REAR AXLE

013 - Adjuster, Slack
016 - Arm, Steering
068 - Spring, Lift
135 - Flange/Yoke, Comp
147 - Carrier
170 - Housing, Axle
203 - Air Bag Assembly
216 - Stud
231 - Chamber
265 - Control (Air Suspension
Control)
323 - Hanger and Crossmember
Assembly

GROUP 15 - FUEL SYSTEM

011 - Cap/Scoop, Air Inlet
014 - Box/Water Separator, Air
Inlet
026 - Pipe, Air Inlet
029 - Control System, Air Inlet
Temperature
142 - Pre-Heater Element
143 - Valve, Drain
144 - Valve, Check
145 - Cap, Vent

GROUP 16- CAB

006 - Stop, Hood
018 - Bezel, Head or Tail Lamp
027 - Step, Cab
053 - Cable, Hood
071 - Channel, Glass Run
078 - Remote Control/Cable,
Door
086 - Crossmember, Cab
Mounting
102 - Cab Tilt Lock Mechanism
103 - Cab Tilt Hinge
Mechanism
104 - Cowl/Firewall/SC or FC
Platform

938 - Gear, Power Steering
Pump Driver
946 - Tensioner, Belt
955 - Pulley/Idler/Bearing

616 - Cooler, Oil (Oil-To-Air)
677 - Line, Oil Cooler
785 - Linkage/Cable, Remote
Shift Control
825 - Switch, On/Off
839 - Switch, Brake
866 - Mounting

357 - Bearings, Internal (Axle
Carrier)
376 - Gears, Bushings & Cross,
Differential
395 - Differential, Limited Slip
424 - Bolt, Ring Gear
441 - Wheel End Gearboxes
448 - Gears, Helical
472 - Gears, Planetary
496 - Gears, Ring & Pinion
590 - Shaft, Helical Drive Gear
606 - Clutch, Sliding
619 - Control, Air Shift

146 - Pump, Primer
147 - Collar
148 - Body
177 - Filler Neck/Cap & Gasket
196 - Sensor, Water in Fuel
216 - Bracket, Stack Mounting
263 - Air Intake Grill
479 - Finish (Metal)
500 - Bracket & Bolts,
Mounting

121 - Suspension, Sleeper Bunk
122 - Cylinder, Lift
123 - Latch Assembly
129 - Cabinets
130 - Door
131 - Window, Sleeper
135 - Cylinder, Lift
139 - Door Assembly, Radiator
Access
146 - Shade, Sun
248 - Grille Assembly
264 - Handle, Grab
265 - Handle, Hood
282 - Hinge

909 - Harness, Cab (Wires,
Connectors & Term)
940 - Harness, PDM
Distribution

630 - Cylinder, Air Shift
654 - Fork, Shift
679 - Motor, Air Shift
707 - Bearing/Ret, P.D.
713 - Pump, Oil
719 - Case, P.D. Diff.
730 - Gears/Bushing & Cross
Power Divider
747 - Tank, Air Or Vacuum
969 - Knuckle, Steerable
970 - King Pin, Knuckle

637 - Tank Body
787 - Tube, Fuel Outlet
857 - Indicator, Air Restriction
890 - Transfer Pump, Electric
(Tank to Tank)
892 - Valve/Control, Fuel Tank
909 - Harness, Cab Wires
Conn's & Terminals
976 - Vent, Air
988 - Guard, Crash

291 - Hinge, Hood/Engine
Access Door Hatch
295 - Hood Guides
300 - Bunk Occupant Restraint
Strap/Tent
301 - Cowl Tray
309 - Hood
329 - Insulation
330 - Shield, Sound
336 - Insulation, Engine
Compartment
345 - Latch & Exterior Handle
362 - Latch, Hood

368 - Latch, Doghouse
 Panel/Engine
 398 - Map Pocket, Passenger
 Door
 409 - Air Intake Baffle/Water
 Sep. Baffle
 421 - Mirror, Spot
 423 - Mirror, Exterior (Basic)
 433 - Mirror, Interior
 459 - Mounting, Front Cab
 463 - Mounting, Intermediate
 Body
 468 - Mounting
 546 - Panel, Back
 555 - Doghouse Panel/Engine
 Cover
 567 - Panel, Floor
 568 - Panel, Halo
 569 - Panel, Engine Surround
 584 - Panel, Instrument
 611 - Panel, Splash
 619 - Panel / Skin
 625 - Rivet/Fastener
 627 - Weld

637 - Structure
 666 - Regulator & Handle,
 Window
 675 - Arm Rest
 684 - Roof
 721 - Spring/Shock Absorber &
 Mounting, Cab
 739 - Stop Assembly, Door
 748 - Sub-Frame
 799 - Console
 802 - Manifest Box/Door Pouch
 804 - Trim, Interior
 805 - Trim, Bunk
 806 - Mirror, Interior
 807 - Under Bunk Lift Assist
 Shock
 811 - Relay/Magnetic Switch
 (Electric Mirror)
 825 - Switch, Electric Mirror
 833 - Valve, Control
 844 - Ventilator
 855 - Visor, Sun
 877 - Vent Window & Seal
 896 - Trim, Hood

909 - Harness, Cab
 (Wires/Connectors/Term)
 926 - Shor Power Connection
 928 - Door, Hood / Engine
 Access
 929 - Hinge / Bracket, Front
 Hood Mounting
 934 - Reinforcement, Hood
 935 - Torsion Bar, Hood Assist
 936 - Latch, Engine Access
 Door
 958 - Bracket, Sun Shade
 Mounting
 972 - Panel, Rear Trim
 973 - Panel, Door Trim - Driver
 Side
 974 - Panel, Door Trim -
 Passenger Side
 975 - Holder, Cup
 991 - Motor, Mirror
 992 - Heater, Mirror
 994 - Bracket, Mirror

GROUP 17 - WHEELS

031 - Disc Wheel
 087 - Hub (Disc Wheel)
 108 - Rim (Demountable)
 386 - Spoke Wheel

GROUP 18 – SCR AFTERTREATMENT

045 - Hose, Pump to Tank
 Supply / Suction
 046 - Hose, Pump to Tank
 Return
 047 - Hose, Pump to Doser /
 Injector
 124 - Sensor Assembly, Def
 Tank
 177 - Cap, Filler Tank
 180 - Cover, Supply Module
 181 - Heater, Tank
 350 - Hose, Tee to Doser
 351 - Hose, Doser To Tee
 500 - Bracket/Strap, Def Tank
 501 - Bracket, Supply Module
 Pump
 502 - Bracket, ACM
 565 - Wiring, (Sensor)
 637 - Tank, Diesel Exhaust
 Fluid
 787 - Pickup, Tank
 793 - Tank Def, Coolant Flow
 Valve
 801 - Module, PDM
 906 - Wiring, ACM
 907 - Wiring, Supply Module
 908 - Wiring, Heated Line
 909 - Wiring, Head Unit

GROUP 19 - ACCESSORIES

001 - Fan, Defroster
 015 - Clutch, Compressor
 028 - Compressor/Reciprocating
 029 - Compressor/Rotary
 043 - Condenser
 045 - Linkage, Wiper
 070 - Switch, Radiator
 Fan/Shutter Override
 076 - Core (Heater)
 094 - Evaporator
 100 - Meter Assembly, Engine
 105 - Wheel, Blower
 138 - Block, Resistor
 149 - Accumulator/Dryer
 182 - Valve, Expansion
 183 - Valve, Rear Expansion
 187 - Ducting, Air
 Cond/Heater/Defroster
 197 - Horn Assembly
 214 - Valve, Control
 251 - Harness, Coiled Ribbon
 (Clock Spring)
 310 - A/C O Ring
 317 - Schrader Valve, Low Side
 318 - Schrader Valve, High Side
 325 - Solenoid, Pneumatic
 327 - Switch, Air Horns
 331 - Electric Air Compressor,
 Seat
 343 - Shock, Seat
 344 - Adjuster Assembly, Seat
 351 - Frame, Seat
 353 - Fitting
 354 - Control, Air Seat
 355 - Mounting/Housing (Main
 Case)
 363 - Bag, Air
 381 - Retractor, Seat Belt
 386 - Belt, Seat
 411 - Plate, Fifth Wheel
 417 - Control, Fifth Wheel

435 - Heater Assembly, Engine
 436 - Socket, Engine Heater
 443 - Back-Up Camera
 472 - Reservoir
 506 - Lock Cylinder, Fifth Wheel
 632 - HVAC Hose, Under Cab to Rear
 675 - Rest, Arm
 708 - Module, Blower Speed LPM
 709 - Module, HVAC Control
 733 - Actuator, Motor/Door - Blend Air

734 - Actuator, Motor / Door – Fresh Air
 735 - Actuator, Motor/Door - Air Distribution
 763 - Sensor, Refrigerant Pressure
 764 - Thermistor, Inlet
 765 - Thermistor, Outlet
 807 - Module, Vehicle Personality (VPM)
 825 - Switch
 826 - Switch, Bunk-On/Off
 827 - Switch Bunk-Temperature Control

830 - Switch, Intermittent
 837 - Switch, Clutch
 838 - Switch, Set-Resume
 849 - Module, Diagnostic - APADS
 880 - Switch, Pressure-Low
 881 - Switch, Pressure-High
 882 - Switch, Thermostatic
 885 - Freeze Sensor
 909 - Harness, Cab (Wires, Connectors and Terminals)
 923 - Harness, Front End (Wires/Connectors/Term)

GROUP 22 - GENESIS BODY - COMP

001 - Fan, Defroster
 040 - Bows
 042 - Cowl, Front
 044 - Frame, Rear
 046 - Rails, Drip
 048 - Rails, Seat
 050 - Spacers, Bow
 052 - Steps
 055 - Bumper, Front
 056 - Bumper, Rear
 060 - Header, Entrance Door
 061 - Frame, Entrance Door
 062 - Drivers Seat Sub-Frame (K Frame)
 063 - Frame, Side Emergency Door
 064 - Frame, Rear Emergency Door
 065 - Frame, Lift Door
 066 - Frame, Body to Cab Floor
 067 - Frame, Body to Cab Roof
 068 - Frame, Davenport
 080 - Bars, Light
 082 - Bumpers, Header
 084 - Caps, Inside
 086 - Insulation
 088 - Lining, Lower
 090 - Lining, Overhead
 092 - Racks, Luggage
 094 - Rails Grab
 096 - Rails, Shoulder
 098 - Rails, Standee
 100 - Reduction, Noise
 120 - Bracket, License Plate
 122 - Caps, Outside
 124 - Caps, Post
 126 - Door, Fuel
 128 - Handles, Access
 129 - Front Fiberglass Panel

130 - Panels, Rear Inside Window
 131 - Front Sheet Metal
 134 - Rails, Rub
 136 - Rails, Snow
 138 - Sheets, Side
 140 - Skins, Rear Outside
 141 - Hatch, Roof
 142 - Skirts
 146 - Roof Panels(Topping)
 148 - Door, Engine
 151 - Door, W/S Wiper
 152 - Grille
 200 - Electrical Access Compartment
 204 - Battery, Compartment
 208 - Spare Tire Compartment
 212 - Luggage Compartment
 214 - Safety Compartment
 216 - Destination Sign Compartment
 218 - Tool Compartment
 239 - Controls Air
 240 - Boxes, Buzzer
 241 - Controls Electric
 243 - Controls, Manual
 244 - Devices, Hold Bac
 246 - Doors, Entrance
 248 - Doors, Lift – Single / Double
 250 - Doors, Emer. Rear
 252 - Doors, Emer. Side
 254 - Handles, Door
 256 - Hinges
 258 - Locks, Door
 262 - Vandalocks
 275 - Light, Step
 281 - Electric Panel
 283 - Fuse Panel
 284 - Horns

294 - Speakers
 296 - Switches
 297 - Radio
 298 - Antenna
 322 - Panels, Floor
 326 - Sills, Floor
 330 - Tiedown Bolts, Plates, J-Bolts, U-Bolts
 332 - Wheel pocket Assy.
 339 - Transition Panel / Cowl Filler Panel
 340 - Doors, Engine Service
 350 - Cross View Mirror
 360 - Cover, Wheel-Pocket
 364 - Moulding, Cove
 366 - Treads, Step
 369 - Wig-Wag
 389 - Child Check Mate
 402 - Window, Driver's
 410 - Window, Emergency Exit
 416 - Window, Split Sash
 423 - Thermistor, Inlet
 425 - Switch, Radiator Fan / Shutter Override
 426 - Window, Split Storm
 427 - Switch, Pressure - Low
 429 - Clutch, Compressor
 430 - A/C Compressor, Rotary
 431 - Ducting, Air Conditioner
 432 - Wheel, Blower
 433 - Hose, A/C
 434 - O-Ring, A/C
 435 - Schrader Valve, Low Side
 436 - Sensor, Refrigerant Pressure
 437 - Switch
 438 - Accumulator / Dryer
 439 - Switch, Pressure - High
 440 - Heater, Under Seat

441 - Harness, (Wires, Connectors, & Terminals)	471 - Harness, Power Distribution (On Flasher Plate)	544 - Red Light
442 - Heater, Rear	472 - Switch, Thermostatic	546 - Stop Light
444 - Covers/Trim, Hose	474 - Thermistor, Outlet	548 - Stop/Tail Light
445 - Control Cable	475 - Tube, Drain	550 - Strobe Light
446 - Driver's Heater	476 - Tube, Orifice	554 - Warning Light
447 - Core, Heater	478 - Motor	556 - Lift Door Light, Interior
449 - Motors, Heater	479 - A/C Electric Control Panel	558 - Lift Door Light, Exterior
450 - Stepwell Heater	480 - Panels, Modesty	560 - Cowl Mount Mirror
451 - Pump, Booster Heater	484 - Restraints, Lap	562 - Fender Mount Mirror / Rear View
453 - Condenser	488 - Stanchions	564 - Heated Mirror
454 - Fan, Condenser	493 - Harness, Left Hand Body	566 - Inside Rear View Mirror
455 - Evaporator	494 - Harness, Right Hand Body	568 - Spy Mirror
456 - Defroster Duct	495 - Harness, Flasher to Cowl	640 - Alarms, Backing
457 - Valve, Expansion	498 - Harness, Body Options External (Engine)	662 - Sign, Designation
459 - Fitting / Pipe (A/C)	499 - Microphone	682 - Crash Barrier Frame
460 - Harness, Front End	501 - Harness, Dash	684 - Belts, Seat
462 - Relay / Magnetic Switch	520 - Back-Up Light	692 - Passenger Seat Frame
463 - Schrader Valve, High Side	524 - Instrument Cluster Light	694 - Shields, Courtesy
464 - Harness, Flasher Plate	526 - Directional Light	697 - Flip Seat Frame
465 - Harness, LH Switch Panel	528 - Directional, Side Light Assembly	720 - Stop Arm
466 - Harness, Rh Switch Panel	534 - Fog Light	726 - Gates, Crossing
467 - Harness, Over Head Switch Panel	536 - Headlights	740 - Motor, Stop Arm
468 - Valve, Water (Dash Mounted A/C Heater Unit)	540 - License Plate Light, Assembly	742 - Motor, Stop Arm Module
469 - Harness, Front Cap	542 - Marker Light	762 - Static Vent
470 - Harness, Rear Cap		810 - Motor, Drive
		812 - Washer

WHAT IS NOT COVERED

Components / Items:

- Correction of loose fasteners, squeaks, rattles and unusual noises.
- Adjustments (e.g., headlights, brake/clutch adjustments, steering system adjustments, coolant levels).
- Items warranted by their respective manufacturers (e.g., non-Navistar brand engines, tires & tubes, Allison Transmissions, clutch, batteries, radios, lubricants, etc).
- Any part that is not a Navistar part number.
- Unauthorized parts other than Navistar service parts or ReNEWed® parts.
- Bodies, equipment and accessories installed by other than authorized Navistar employees at Navistar manufacturing plants.
- Front and rear axle alignment.
- Engine, Engine Electronics, Injectors, Turbocharger.
- Hybrid Electric Components (except Hybrid/Electric Drive Cooling).

Repairs:

- Maintenance-related items/ repairs or those as a result of normal wear and tear, including tune-ups, brake/clutch lining, clutch brake, windshield wiper blades, windshield wiper nozzles, gaskets, belts, seals, tire balancing, lubrication, batteries and other similar procedures/parts required to keep vehicle in good working condition. Such maintenance items or repairs include, but are not limited to oil changes, oil filters, air filters, desiccant cartridge, fuel filters, tire rotation, cleaning/polishing, engine tune-up, adding oils, tightening of air intake and coolant clamps, ash tray, cigarette lighter element, fire extinguishers, fluorescent ballast and tubes, fuses, gladhand and gladhand rubbers, trailer hoses, hose tenders, trailer electrical cables, light bulbs, mattress, mud flaps, mud flap mounting bracket.



- Repairs to any part of the vehicle subjected to misuse, negligence, improper maintenance, improper operation, or which is the result of an accident.
- Fades, runs, mismatch or damage to paint, trim items, upholstery, chrome, polished surfaces, etc., resulting from environmental causes, improper polishes, cleaners or washing solutions, or chemical and industrial fallout.
- No coverage will be granted if Power Train, Propshaft and Suspension sales guidelines (specifications) are not strictly adhered to by all owners and operators of this vehicle.
- Accidents, acts of nature or other events beyond control of Navistar.
- Any single repair requiring less than \$40.00 parts and labor to complete.

Other:

- Vehicles sold and/or operated outside the United States or Canada.
- Vehicles/components which have had unauthorized alterations or modifications.
- Vehicles on which the odometer reading has been altered.
- Incidental or consequential costs or expenses which the owner may incur as a result of a malfunction or failure covered by this warranty, such as vehicle damage, communication expenses, meals, lodging, overtime, loss of use of engine or vehicle (“downtime”), loss of time, inconvenience, cargo loss or damage, and other similar costs and expenses.
- Replacement of defective parts, which were, not authorized Navistar equipment when first installed.
- Towing, unless additionally purchased.

OBTAINING SERVICE

To obtain service under this Service Contract, return this vehicle to any Navistar truck dealer authorized to service this model vehicle and engine. To locate an authorized dealer near you, please call the Navistar Customer Service Center at 800-44-TRUCK (800-448-7825).

DISCLAIMER

NO WARRANTIES ARE GIVEN BEYOND THOSE DESCRIBED HEREIN. THIS WARRANTY IS IN LIEU OF ALL OTHER WARRANTIES, EXPRESSED OR IMPLIED. THE COMPANY SPECIFICALLY DISCLAIMS WARRANTIES OF MERCHANTABILITY AND FITNESS FOR A PARTICULAR PURPOSE, ALL OTHER REPRESENTATIONS TO THE USER/PURCHASER, AND ALL OTHER OBLIGATIONS OR LIABILITIES. THE COMPANY FURTHER EXCLUDES LIABILITY FOR INCIDENTAL AND CONSEQUENTIAL DAMAGES, ON THE PART OF THE COMPANY OR SELLER. No person is authorized to give any other warranties or to assume any liabilities on the company’s behalf unless made or assumed in writing by the Company; and no other person is authorized to give any warranties or to assume any liabilities on the seller’s behalf unless made or assumed in writing by the seller.

Remedies Under State or Provincial Law: Some States and Provinces do not allow the exclusion or limitation of incidental or consequential damages, so the above limitation or exclusion may not apply to the owner. This warranty gives the owner specific legal rights, and he may also have other legal rights which may vary by state or province.

Navistar, Inc., except in Canada where it is Navistar Canada, Inc.

TOW COVERAGE \$1,100 PER INCIDENT

This service contract for **Towing option(s)** provides coverage for 24 months or unlimited miles/kilometers traveled from new vehicle delivery date, whichever expiration occurs first.

During this period, Navistar, Inc. ("Navistar") will pay for a service call and/or towing to the nearest IC Bus, International[®] or Cummins dealer WITH A NAVISTAR OR CUMMINS WARRANTABLE AND MISSION-DISABLING UNSAFE OPERATING CONDITION FAILURE. Coverage of Cummins failure begins AFTER the expiration of the Cummins second year of standard tow coverage for school bus if an additional Cummins service contract is active in Navistar Service Portal. Maximum liability for Navistar, per incident, is \$1,100. Exceptions are listed herein under section *What is Not Covered*.

WHAT IS NOT COVERED**Repairs:**

- Towing in connection with a failure that is NOT warranted with Cummins or Navistar.
- Any expense over the \$1,100.00 maximum liability, per incident.

Other:

- Buses sold and/or operated outside the United States and Canada.
- Buses /components which have had unauthorized alterations or modifications.
- Buses on which the odometer reading has been altered.
- Loss of time or use of the bus, loss of profits, inconvenience, or other consequential or incidental damages or expenses.
- Incidental or consequential costs or expenses which the owner may incur as a result of a malfunction or failure covered by this warranty, such as vehicle damage, communication expenses, meals, lodging, overtime, loss of use of engine or vehicle ("downtime"), loss of time, inconvenience, cargo loss or damage, and other similar costs and expenses.

OBTAINING SERVICE

To obtain service under this Service Contract, return this vehicle to any IC Bus or International[®] truck dealer authorized to service this model bus and engine. To locate an authorized dealer near you, please call the Navistar Customer Service Center at 800-44-TRUCK (800-448-7825).

DISCLAIMER

FOLLOWING THE EXPIRATION OF THE STANDARD NAVISTAR LIMITED WARRANTY AND DURING THE PERIOD OF THIS SERVICE CONTRACT, NO WARRANTIES OR ADDITIONAL COVERAGE ARE GIVEN BEYOND THOSE DESCRIBED HEREIN. THIS EXTENDED WARRANTY IS IN LIEU OF ALL OTHER WARRANTIES, EXPRESSED OR IMPLIED, EXCEPT FOR THE APPLICABLE STANDARD NAVISTAR LIMITED WARRANTY FOR YOUR VEHICLE. NAVISTAR SPECIFICALLY DISCLAIMS WARRANTIES OF MERCHANTABILITY AND FITNESS FOR A PARTICULAR PURPOSE, ALL OTHER REPRESENTATIONS TO THE USER/PURCHASER, AND ALL OTHER OBLIGATIONS OR LIABILITIES. NAVISTAR FURTHER EXCLUDES LIABILITY FOR INCIDENTAL, SPECIAL, INDIRECT AND CONSEQUENTIAL DAMAGES, ON THE PART OF NAVISTAR OR SELLER. No person is authorized to give any other warranties or to assume any liabilities on Navistar's behalf unless specifically made or assumed in writing by Navistar; and no other person is authorized to give any warranties or to assume any liabilities on the seller's behalf unless specifically made or assumed in writing by the seller.

Remedies Under State or Provincial Law: Some States and Provinces do not allow the exclusion or limitation of incidental or consequential damages, so the above limitation or exclusion may not apply to the owner. This warranty gives the owner specific legal rights, and he may also have other legal rights which may vary by state or province.

Navistar, Inc., except in Canada where it is Navistar Canada, Inc.

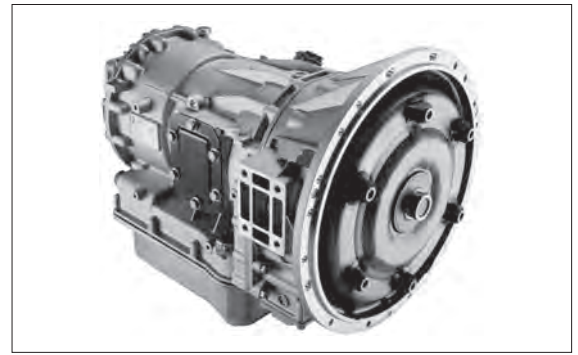

2500/2550 Series

International Series 2500/2550

RATINGS

Model ⁽¹⁾	Gross Input Torque ⁽²⁾ N•m	Gross Input Power ⁽²⁾ kW (hp)	Gross Input Torque ⁽²⁾⁽³⁾ N•m	Gross Input Power ⁽²⁾⁽³⁾ kW (hp)	GVW kg	GCW kg
2500 General	780	224 (300)	895	254 (340)	15,000	15,000
	746	224 (300)	766	224 (300)	12,000	12,000
	705	149 (200)	750	164 (220)	15,000	15,000
2500 MH Motorhome	746	224 (300)	895	254 (340)	15,000	15,000
2500 SP Specialty Vehicles	CONTACT YOUR ALLISON REPRESENTATIVE FOR DETAILS					
2550 General	780	224 (300)	895	224 (300)	13,600	13,600
	705	149 (200)	750	149 (200)	13,600	13,600
2550 SP Specialty Vehicles	CONTACT YOUR ALLISON REPRESENTATIVE FOR DETAILS					

(1). Models including vocational designations (ie: ORS, OF5, SP, MH) are for global markets. All other models within this document are targeted for outside North American markets only.
 (2). Gross ratings as defined by ISO 1585 or SAE J1995. (3). Shift Energy Management (SEM) engine controls and torque limiting are required to obtain this rating.

DRIVETRAIN INTERFACES

Acceptable full-load engine governed speed	2200 – 3800* rpm
Acceptable engine idle speed range (with transmission in Drive)	500 – 820 rpm
Maximum output shaft speed at 105 km/hr (65 mi/hr)	4500 rpm

* Engines with full load governed speed greater than 3800 rpm require Application Engineering review

MOUNTING

To Engine SAE No.3, SAE No.2

TORQUE CONVERTER

Type One stage, three element, polyphase.
Includes standard integral damper which is operational in lockup.

Model	Stall Torque Ratio
TC-210	2.05
TC-211	1.91
TC-221	1.73
TC-222	1.58

MECHANICAL RATIOS (Gear ratios do not include torque converter multiplication)

Range	
First	3.51 : 1
Second	1.90 : 1
Third	1.44 : 1
Fourth	1.00 : 1
Fifth	0.74 : 1
Sixth	0.64 : 1
Reverse	-5.09 : 1

CONTROL SYSTEM

Description Allison 5th Generation Electronic Controls with closed loop adaptive shifts

Shift Sequences [C = Converter mode (lockup clutch disengaged); L = Lockup mode (lockup clutch engaged)]

Option 1: 1C-[1L]-2C-2L-3L-4L-5L

Option 2: 1C-[1L]-2C-2L-3L-4L-5L-6L

Driver-to-Transmission Interface

Cab-mounted shift selector

Communication Protocol - Engine/Vehicle Systems Interface

SAE J1939, IESCAN, PT-CAN

PHYSICAL DESCRIPTION

	Installation Length*	Dry Weight	Depth below transmission centerline	
			With Shallow Oil Sump	With Deep Oil Sump
SAE No.3	729 mm	150 kg	272 mm	285 mm
SAE No.2	739 mm	150 kg	272 mm	285 mm

*Approximate length from engine housing to output flange (depending on output flange type)

TURBINE-DRIVEN POWER TAKE-OFF PROVISION

PTO drive	Torque converter turbine-driven spur gear
PTO mounting pads	Six-bolt, 3 o'clock and 9 o'clock positions (as viewed from rear)
PTO drive gear rating (continuous operation)	Using one PTO: 339 N•m Total using two PTO's: 271 N•m
PTO drive gear ratio	1.00 x turbine speed
PTO drive gear	64 tooth

OIL SYSTEM

Allison approved fluids: TES 295 and TES 389

Capacity, excluding external circuits

With Deep Oil Pan 14 litres

With Shallow Oil Pan 12 litres

Spin on canister filter Standard

SPEEDOMETER PROVISION

Description	Non-zero-crossing square wave
Location	8, 16 or 40 pulses per revolution of transmission output shaft Electronic output from TCM

TACHOGRAPH PROVISION

Tone wheel	6-tooth
Mounting Location	M18 x 1.5 metric thread Transmission rear cover

2500/2550 Series

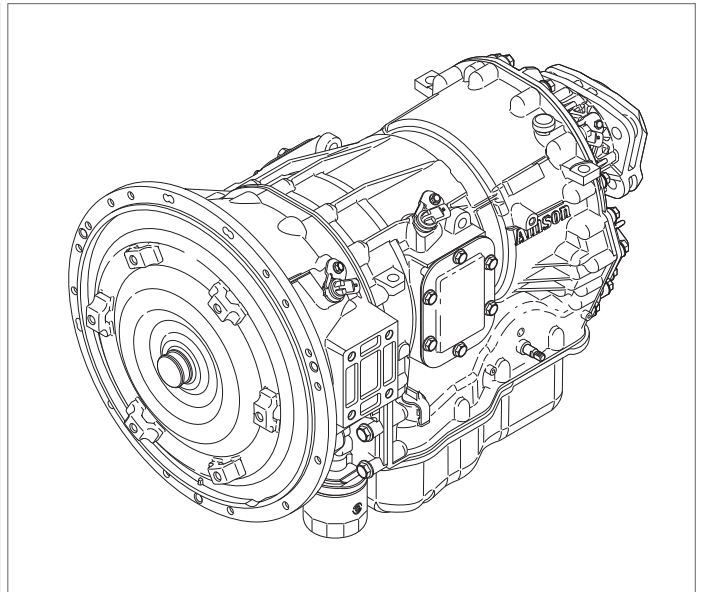
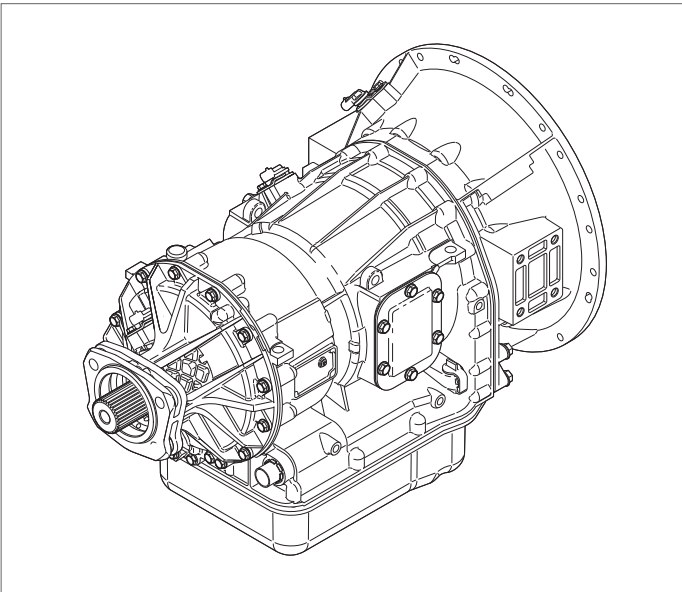



All IC School Buses come with: PROMOTIONAL PACKAGE 84 Month Unlimited Miles/km Warranty, Limited Time Program for Allison 2000 Series Transmission (Supplied directly through Allison)

Allison 3000 Series Transmission 60 Month Unlimited Miles/km Warranty (Supplied directly through Allison)

Cummins Warranty

All Engines United States And Canada School Bus

Coverage

Products Warranted

This Warranty applies to new diesel, LPG, compressed or liquid natural gas fueled Engines sold by Cummins Inc. or Cummins Westport and delivered to the first user on or after September 15, 1996, that are used in school bus* applications in the United States** or Canada.

Base Engine Warranty

The Base Engine Warranty covers any failures of the Engine which result, under normal use and service, from a defect in material or factory workmanship (Warrantable Failure). This Coverage begins with the sale of the Engine by Cummins and continues for five years or 100,000 miles (160,934 kilometers), whichever occurs first, from the date of delivery of the Engine to the first user.

Engine aftertreatment components included in the Cummins Critical Parts List (CPL) and marked with a Cummins part number are covered under Base Engine Warranty.

Extended Major Components Warranty

The Extended Major Components Warranty applies to all except ISV, ISB6.7 G, B and ISB Series Engines and covers Warrantable Failures of the Engine cylinder block, camshaft, crankshaft and connecting rods (Covered Parts).

Bushing and bearing failures are not covered.

This Coverage begins with the expiration of the Base Engine Warranty and ends three years or 300,000 miles (482,804 kilometers), whichever occurs first, from the date of delivery of the Engine to the first user.

Emission Warranty

Additional Coverage is outlined under the Emission Warranty.

THESE WARRANTIES ARE MADE TO ALL OWNERS IN THE CHAIN OF DISTRIBUTION AND COVERAGE CONTINUES TO ALL SUBSEQUENT OWNERS UNTIL THE END OF THE PERIODS OF COVERAGE.

Cummins Responsibilities

During The Base Engine Warranty

Cummins will pay for all parts and labor needed to repair the damage to the Engine resulting from a Warrantable Failure.

Cummins will pay for the lubricating oil, antifreeze, filter elements, belts, hoses and other maintenance items that are not reusable due to the Warrantable Failure.

Cummins will pay for reasonable labor costs for Engine removal and reinstallation when necessary to repair a Warrantable Failure.

Cummins will pay reasonable costs for towing a vehicle disabled by a Warrantable Failure to the nearest

authorized repair location when necessary to make the repair for the first 2 years from the date of delivery of the Engine to the first user. In lieu of towing expenses, Cummins will pay reasonable costs for mechanics to travel to and from the location of the vehicle, including meals, mileage and lodging, when the repair is performed at the site of the failure.

During The Extended Major Components Warranty

Cummins will pay for the repair or, at its option, replacement of the defective Covered Part and any Covered Part damaged by a Warrantable Failure of the defective Covered Part.

Owner Responsibilities

During The Base Engine Warranty

Owner is responsible for the cost of lubricating oil, antifreeze, filter elements and other maintenance items provided during Warranty repairs unless such items are not reusable due to the Warrantable Failure.

During The Extended Major Components Warranty

Owner is responsible for the cost of all labor needed to repair the Engine, including the labor to remove and reinstall the Engine. When Cummins elects to repair a part instead of replacing it, Owner is not responsible for the labor needed to repair the part.

Owner is responsible for the cost of all parts required for the repair except for the defective Covered Part and any Covered Part damaged by a Warrantable Failure of the defective Covered Part.

Owner is responsible for the cost of lubricating oil, antifreeze, filter elements and other maintenance items replaced during the repair.

During The Base Engine And Extended Major Components Warranties

Owner is responsible for the operation and maintenance of the Engine as specified in the applicable Cummins Operation and Maintenance Manual. Owner is also responsible for providing proof that all recommended maintenance has been performed.

Before the expiration of the applicable Warranty, Owner must notify a Cummins distributor, authorized dealer or other repair location approved by Cummins of any Warrantable Failure and make the Engine available for repair by such facility. Except for Engines disabled by a Warrantable Failure during the first two years from the date of delivery of the Engine to the first user, Owner must also deliver the Engine to the repair facility.

Service locations are listed on the Cummins Worldwide Service Locator at cummins.com.

Owner is responsible for communication expenses, meals, lodging and similar costs incurred as a result of a Warrantable Failure.

Owner is responsible for non-Engine repairs and for "downtime" expenses, passenger delays, fines, all applicable taxes, all business costs and other losses resulting from a Warrantable Failure.

Limitations

Engines with an emissions certification listed below must be operated using only diesel fuel having no more than the corresponding maximum sulfur content. Failure to use the specified fuel as listed in the Cummins Fuel Bulletin #3379001 Table 1 (Cummins Inc. Required Diesel Fuel Specifications) can damage the Engine and aftertreatment system within a short period of time. This damage could cause the Engine to become inoperable and failures attributable to the use of incorrect fuels will be denied Warranty Coverage. Fuel specifications also need to comply with local fuel regulations (EN590 for Europe and ASTM D975 for North America) for Warranty eligibility.

Maximum sulfur levels by emissions certification level as listed on the Engine's dataplate are:

EPA 2007/2010/2013/2017/2021	max. 15 parts per million
EPA Tier 4 Interim / Final / Stage V in North America	max. 15 parts per million
EU Stage IIIB 2011	max. 15 parts per million
EU Stage IV 2011	max. 15 parts per million
EU Stage V	max. 10 parts per million
Euro 4/5	max. 50 parts per million
Euro 6	max. 10 parts per million

Cummins is not responsible for failures or damage resulting from what Cummins determines to be abuse or neglect, including, but not limited to: operation without adequate coolants or lubricants; overfueling; overspeeding; lack of maintenance of lubricating, cooling or intake systems; improper storage, starting, warm-up, run-in or shutdown practices; unauthorized modifications of the Engine.

Any unauthorized modifications to the aftertreatment system could negatively affect emissions certification and void the Warranty.

Cummins is also not responsible for failures caused by incorrect oil, fuel or diesel exhaust fluid or by water, dirt or other contaminants in the fuel, oil or diesel exhaust fluid.

Alternators and starters are covered for the first two years from the date of delivery of the Engine to the first user, or the expiration of the Base Engine Warranty, whichever occurs first.

Excessive oil consumption for ISV and B Series Engines is covered for the duration of the Coverage. Before a claim for excessive oil consumption will be considered, Owner must submit adequate documentation to show that consumption exceeds Cummins published standards.

Failures of belts and hoses supplied by Cummins are not covered beyond the first year from the date of delivery of the Engine to the first user or the expiration of the applicable Base Engine Warranty, whichever occurs first.

Parts used to repair a Warrantable Failure may be new Cummins parts, Cummins approved rebuilt parts or repaired parts. Cummins is not responsible for failures resulting from the use of parts not approved by Cummins.

A new Cummins or Cummins approved rebuilt part used to repair a Warrantable Failure assumes the identity of the part it replaced and is entitled to the remaining Coverage hereunder.

Cummins, Inc. reserves the right to interrogate Electronic Control Module (ECM) data for purposes of failure analysis.

CUMMINS DOES NOT COVER WEAR OR WEAROUT OF COVERED PARTS.

CUMMINS IS NOT RESPONSIBLE FOR INCIDENTAL OR CONSEQUENTIAL DAMAGES.

THESE WARRANTIES AND THE EMISSION WARRANTY SET FORTH HEREINAFTER ARE THE SOLE WARRANTIES MADE BY CUMMINS IN REGARD TO THESE ENGINES. CUMMINS MAKES NO OTHER WARRANTIES, EXPRESS OR IMPLIED, OR OF MERCHANTABILITY OR FITNESS FOR A PARTICULAR PURPOSE.

This Warranty gives you specific legal rights, and you may also have other rights which vary from state to state.

Emission Warranty

Products Warranted

This Emission Warranty applies to new Engines marketed by Cummins that are used in the United States** or Canada in vehicles designed for transporting persons or property on a street or highway. This Warranty applies to Engines delivered to the ultimate purchaser on or after January 1, 1996.

Coverage

Cummins warrants to the ultimate purchaser and each subsequent purchaser that the Engine is designed, built and equipped so as to conform at the time of sale by Cummins with all U.S. federal emission regulations applicable at the time of manufacture and that it is free from defects in material or factory workmanship which would cause it not to meet these regulations within the longer of the following periods: (A) Five years or 100,000 miles (160,934 kilometers) of operation, whichever occurs first, as measured from the date of delivery of the Engine to the ultimate purchaser, or (B) The Base Engine Warranty.

If the vehicle in which the Engine is installed is registered in the state of California, a separate California Emission Warranty also applies.

Limitations

Engines with an emissions certification listed below must be operated using only diesel fuel having no more than the corresponding maximum sulfur content. Failure to use the specified fuel as listed in the Cummins Fuel Bulletin #3379001 Table 1 (Cummins Inc. Required Diesel Fuel Specifications) can damage the engine and aftertreatment system within a short period of time. This damage could cause the engine to become inoperable and failures attributable to the use of incorrect fuels will be denied Warranty Coverage. Fuel specifications also need to comply with local fuel regulations (EN590 for Europe and ASTM D975 for North America) for Warranty eligibility.

Maximum sulfur levels by emissions certification level as listed on the Engine's dataplate are:

EPA 2007/2010/2013/2017/2021	max. 15 parts per million
EPA Tier 4 Interim / Final / Stage V in North America	max. 15 parts per million
EU Stage IIIB 2011	max. 15 parts per million
EU Stage IV 2011	max. 15 parts per million
EU Stage V	max. 10 parts per million
Euro 4/5	max. 50 parts per million
Euro 6	max. 10 parts per million

Failures, other than those resulting from defects in material or factory workmanship, are not covered by this Warranty.

Cummins is not responsible for failures or damage resulting from what Cummins determines to be abuse or neglect, including, but not limited to: operation without adequate coolants or lubricants; overfueling; overspeeding; lack of maintenance of lubricating, cooling or intake systems; improper storage, starting, warm-up, run-in or shutdown practices; unauthorized modifications of the Engine.

Any unauthorized modifications to the aftertreatment system could negatively affect emissions certification and void the Warranty.

Cummins is also not responsible for failures caused by incorrect oil, fuel or diesel exhaust fluid or by water, dirt or other contaminants in the fuel, oil or diesel exhaust fluid.

Cummins is not responsible for non-Engine repairs, "downtime" expenses, cargo damage, fines, all applicable taxes, all business costs or other losses resulting from a Warrantable Failure.

CUMMINS IS NOT RESPONSIBLE FOR INCIDENTAL OR CONSEQUENTIAL DAMAGES.

* A vehicle used to transport students to and from school. Vehicle must be painted yellow, should have warning lights and the words 'SCHOOL BUS' written on the front

and rear roof caps. The requirements pertaining to paint color, warning lights and 'SCHOOL BUS' inscription would not apply if the vehicle is exclusively used to transport students for school related activities and it is owned by a school district.

** United States includes American Samoa, the Commonwealth of Northern Mariana Islands, Guam, Puerto Rico and the U.S. Virgin Islands.



Cummins Inc.
Box 3005
Columbus, IN 47202-3005
U.S.A.

Bulletin No. 3381329
Printed in U.S.A. Rev 3/20
©1999 Cummins Inc.

B6.7™

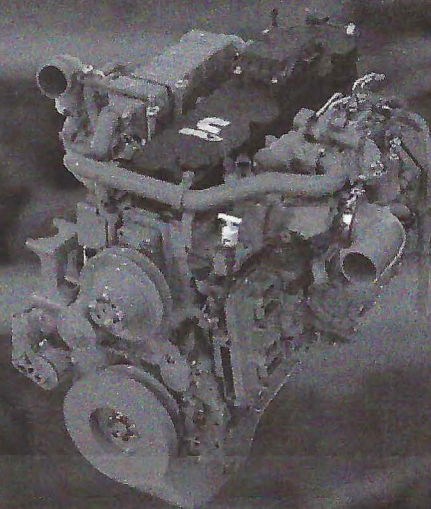

PROVEN TRACK RECORD

The Cummins B6.7™ is one of the most dependable, durable and reliable medium-duty engines available. It's been tested and proven with more than 12 million engines produced over nearly 40 years, with billions of miles driven. These figures aren't just milestones either. They represent years of experience learning and optimizing the product into what we produce today – the most reliable B6.7 Cummins has ever built. We're proud of this history and proud that Cummins medium-duty products power more school buses in operation across North America than any other engines.

REDUCED OPERATING COSTS

We know total cost of operation (TCO) is important to our customers, which is why we focused on making enhancements to reliability and durability while also lowering the TCO. New for EPA 2021, the B6.7 features upgrades that allow for extended engine maintenance intervals, including longer oil drain intervals, more time between fuel filter changes and a completely maintenance-free crankcase ventilation filter. Also new for 2021, the B6.7 offers advancements in connectivity to find, prevent and resolve issues faster.

WE HAVE YOUR BACK

The B6.7 comes with a 5-year / 100,000-mile base warranty. For added peace of mind, we offer multiple extended coverage plan options up to 10 years, designed to provide you with the coverage you need for your operation. All Cummins products are backed by the largest, most capable support network in North America. With over 3,700 certified repair locations across the U.S. and Canada, your school buses are never far from a Cummins-certified technician.

B6.7 MAINTENANCE INTERVALS

Maintenance Item	Miles/ Kilometers	Hours	Months
*Oil and Filter	30,000 mi/48,000 km	1,000	18
Fuel Filter	60,000 mi/96,000 km	2,000	18
Overhead Adjustment	150,000 mi/240,000 km	5,000	48
Coolant Check	15,000 mi 24,000 km	500	6
DEF Filter	200,000 mi 320,000 km	6,500	N/A
Particulate Filter Cleaning	200,000 mi 320,000 km	6,500	N/A
Crankcase Ventilation Filter	N/A	N/A	N/A

* With a 19-quart oil pan. Duty-cycle dependent.

Consult your Operation and Maintenance Manual for more information.

B6.7 SCHOOL BUS RATINGS

Engine Model	Advertised HP (kW)	Peak Torque LB-FT (N•m) @ RPM	Governed Speed
B6.7 260	260 (194)	660 (896) @ 1600	2600
B6.7 250	250 (187)	660 (896) @ 1600	2600
B6.7 240	240 (179)	560 (760) @ 1600	2600
B6.7 220	220 (164)	600 (814) @ 1600	2600
B6.7 220	220 (164)	520 (206) @ 1600	2600
B6.7 200	200 (149)	520 (206) @ 1600	2600

OVER THE AIR PROGRAMMING CAPABILITY.

When connected to a compatible and participating telematics system, Cummins Connected Software Updates facilitate engine control module calibrations remotely in about five minutes, which slashes downtime by eliminating a traditionally scheduled visit to the service bay. Once Cummins Connected Software Updates have been integrated, customers can leverage the same technology to take advantage of Cummins full upcoming suite of over-the-air programming solutions designed to enhance performance, safety and fuel efficiency.

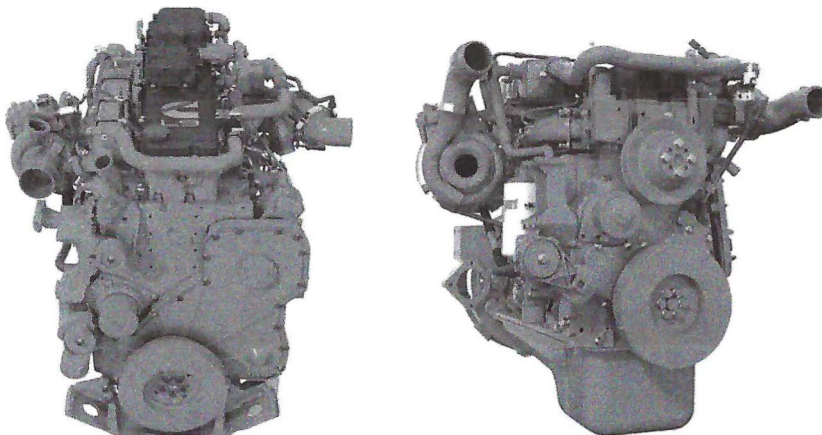

Cummins Inc.
Box 3005
Columbus, IN 47202-3005
U.S.A.

1-800-CUMMINS™ (1-800-286-6467)
cummins.com

Bulletin 5544101 Printed in U.S.A. Rev. 9/20
©2020 Cummins Inc.



Bendix® Wingman® Advanced™

A Collision Mitigation Technology



Bendix



A powerful combination of collision mitigation and full stability technologies

WINGMAN
Advanced

Bendix® Wingman® Advanced™



The Key is Active Braking

The Bendix® Wingman® Advanced™ system is the latest innovation for school buses from the industry leader in active braking technologies – Bendix Commercial Vehicle Systems. Bendix Wingman Advanced brings together adaptive cruise control with braking features along with collision mitigation technology, and our full-stability technology – Bendix® ESP® – providing your fleet with a system that can help. Your fleet benefits from a potent combination of active safety technologies that can help your drivers in collisions, roll-overs, and loss-of-control situations. In addition, the system can provide data, to help keep you in the know about what's happening out on the road.

Helping your drivers on the roadway

When the distance between your driver's bus and the vehicle they're following starts to close, Bendix Wingman Advanced provides the driver following distance alerts and, if necessary, will apply the brakes to help the driver potentially avoid the collision, or help reduce its severity.

Bendix Wingman Advanced features stationary object alerts. These alerts give the driver a warning (up to 3.0 seconds) of a metallic object, such as a stalled car, blocking the lane of travel.

Providing information you can use

Performance on the road is important, but you also need actionable information to know what's happening out there. The Bendix Wingman Advanced system can deliver important data your school bus fleet can use, such as following distance information, alerts given, and stability events. Knowing about close calls and other insights from the road can help you assess and update your driver training needs and support fleet operations.

Making a positive contribution to your bottom line

It's all about getting a quick return on your safety investment. The Bendix Wingman Advanced system helps your fleet in multiple ways. By helping drivers potentially avoid rear-end collisions or, at least, help reduce their severity, your fleet may see fewer accidents and less accident-related costs. Also, a number of alerts will now be available to drivers to help them on their daily routes, such as an impact alert, stationary object alert, and following distance alerts, which should increase safety and reduce accident-related costs.

Bendix® Wingman® Advanced™ Features

Alerts (are always available whether cruise control is engaged or not)

- *Following Distance Alerts* – audible and visual alerts which let drivers know when getting too close to a forward vehicle ✓
- *Impact Alerts* – audible and visual alerts warning the driver that a collision with the forward vehicle is likely and that they should address the situation immediately ✓
- *Stationary Object Alerts* – audible and visual alerts that provide the driver up to a 3.0 second alert when a metallic object(s) may be blocking the lane of travel ✓

Adaptive Cruise Control with Braking (functions when cruise control is on and speed is set)

- Reduces throttle to help the driver maintain a set following distance behind a forward vehicle ✓
- Engages the engine retarder to help the driver maintain a set following distance behind a forward vehicle ✓
- Applies the foundation brakes to help the driver maintain a set following distance behind a forward vehicle ✓

Electronic Stability System

- Bendix® ESP® full stability system to help drivers mitigate rollovers and loss-of-control situations on wet and dry roadways ✓

Collision Mitigation (functions whether or not cruise control is on and speed is set)

- Provides audible and visual alerts to the driver and applies the brakes when the system determines a collision with a forward vehicle is imminent ✓



The Bendix Wingman Advanced system doesn't replace the need for safe drivers

No school bus safety technology replaces the most important safety components of all – a skilled, alert professional driver exercising safe driving habits, as well as continuous, comprehensive driver training. Responsibility for the safe operation of the vehicle remains with the driver at all times.

Warranty Coverage 36 Months, 350,000 Miles

The Key is Active Braking



Help your drivers & your students everywhere, every day...

The Bendix® Wingman® Advanced™ system:

Provides more control on slick surfaces;

Apply the brakes automatically on a slick or icy roadway and the risk of losing control increases. Bendix Wingman Advanced is built on the Bendix® ESP® full stability system. Full stability does more than roll-only systems to help keep school buses under control when brakes are automatically applied on slick surfaces.

Delivers more braking power when your drivers need it;

Bendix Wingman Advanced delivers up to 2/3 (67%) of vehicle braking power. By building on a full-stability platform, all brakes – steer & drive – are available and can be controlled as necessary to provide maximum braking power and a more even braking distribution.

Less wear and tear on your brakes which equals lower maintenance costs, less vehicle downtime;

The adaptive cruise control with braking feature of Bendix Wingman Advanced helps your drivers keep a set following distance by reducing throttle, engaging the engine retarder or, if necessary, applying the brakes. This progressive approach means brakes only get used when they're really needed resulting in less brake wear and more savings.

Delivers "Always Available" driver alerts;

As following distance closes, drivers receive unique visual and audible warnings to aid their response. Fewer false warnings means drivers react when the system alerts.

Alerts drivers to stationary road hazards;

Stationary object alert can provide drivers with an extra warning about metallic objects such as standing vehicles blocking their lane of travel day or night, rain or shine, fog or snow.

Provides useful information; and

Delivers valuable data about following distance, alerts, and stability interventions that you can use to help target driver training needs.

Cost justified, proven safety.

Potentially avoiding a collision or reducing the severity of just one crash can add up to substantial savings from accident and other related costs. With young lives at stake, safety for students is always a number one priority.

For complete details about the Bendix® Wingman® Advanced™ system, contact your Bendix Account Manager, call 1-800-AIR-BRAKE (1-800-247-2725), or visit bendix.com today.

Bendix® ESP® stability for added protection and performance

Bendix ESP, with over 600,000 systems delivered, is an integral part of the Bendix Wingman Advanced system, helping your drivers mitigate roll-over and loss-of-control situations on dry, wet, snow and ice-covered pavement. Plus, Bendix ESP helps Bendix Wingman Advanced use more brakes on the vehicle to deliver more braking power and better balanced brake applications.

**600,000+**
Delivered

IC Bus Servicing Dealers

International Dealer	Address	Phone
Border International Trucks El Paso	12283 Rojas Dr, El Paso, TX 79936	(915) 858-4644
Graham International Inc Sherman	5800 Texoma Pkwy, Sherman, TX 75090	(903) 892-2122
Graham International, Inc. Paris	2945 NE Loop 286, Paris, TX 75460	(903) 784-6683
Kyrish Truck Center of Houston	14201 Hempstead Rd, Houston, TX 77040	(713) 690-1700
Kyrish Truck Center of Houston	8900 N Loop E Fwy, Houston, TX 77029	(713) 674-3444
Kyrish Truck Center of Pharr	711 N Cage Blvd, Pharr, TX 78577	(956) 961-4681
Kyrish Truck Center of Victoria	2605 Port Lavaca Dr, Victoria, TX 77901	(361) 575-1481
Kyrish Truck Centers of Austin North	16336 N. Interstate 35, Austin, TX 78728	(512) 813-6868
Kyrish Truck Centers of Austin South	5010 Burleson Rd, Austin, TX 78744	(512) 389-1111
Kyrish Truck Centers of Beaumont	2465 W Cardinal Dr, Beaumont, TX 77705, USA	(409) 617-0975
Kyrish Truck Centers of Bryan	4050 Hwy 21 East, Bryan, TX 77808	(979) 778-7481
Kyrish Truck Centers of Corpus Christi	7749, I-37, Corpus Christi, TX 78409	(361) 289-5151
Kyrish Truck Centers of Temple	6043 N General Bruce Dr., Temple, TX 76501	(254) 778-3648
Kyrish Trucks Centers of San Antonio, TX	1380 Ackerman Rd, San Antonio, TX 78219	(210) 661-8371
Longhorn Bus Sales	9100 N Loop E Fwy, Houston, TX 77029	(713) 631-9306
Longhorn Bus Sales South	221 W Expy 83, La Feria, TX 78559	(956) 797-3006
Pliier International	3016 S Eastman Rd, Longview, TX 75602	(903) 758-3351
Price International Trucks Tyler	5033 HIGHWAY 271 N, Tyler, TX 75708	(903) 225-4042
Roberts Truck Center Amarillo	4378 Canyon Dr, Amarillo, TX 79109	(806) 355-9771
Roberts Truck Center Lubbock	4510 Avenue A, Lubbock, TX 79404	(806) 763-8213
Roberts Truck Center Midland	10101 I-20 Frontage, Midland, TX 79706	(432) 697-2241
Roberts Truck Center San Angelo	617 N Bell St, San Angelo, TX 76903	(325) 655-7187
Roberts Truck Center Tye	550 S Access Rd, Tye, TX 79563	(325) 677-3393
Rotex Truck Center Lerado	11802 Sara Rd, Laredo, TX 78045	(956) 722-1250
Southwest International Trucks Arlington	2401 E Pioneer Pkwy, Arlington, TX 76010	(817) 664-2900
Southwest International Trucks Fort Worth	617 North Fwy, Fort Worth, TX 76102	(817) 336-4651
Southwest International Trucks McKinney	2105 N Central Expy, McKinney, TX 75070	(972) 629-3600
Southwest International Trucks Waco	3920 N Interstate 35 Frontage Rd South, Waco, TX 76706	(254) 340-6700
Southwest International Trucks, Inc.	3722 Irving Blvd, Dallas, TX 75247	(214) 689-1400
Summit Truck Group Wichita Falls	2401 Central E Fwy, Wichita Falls, TX 76302	(940) 322-7845

IC Bus Servicing Dealers

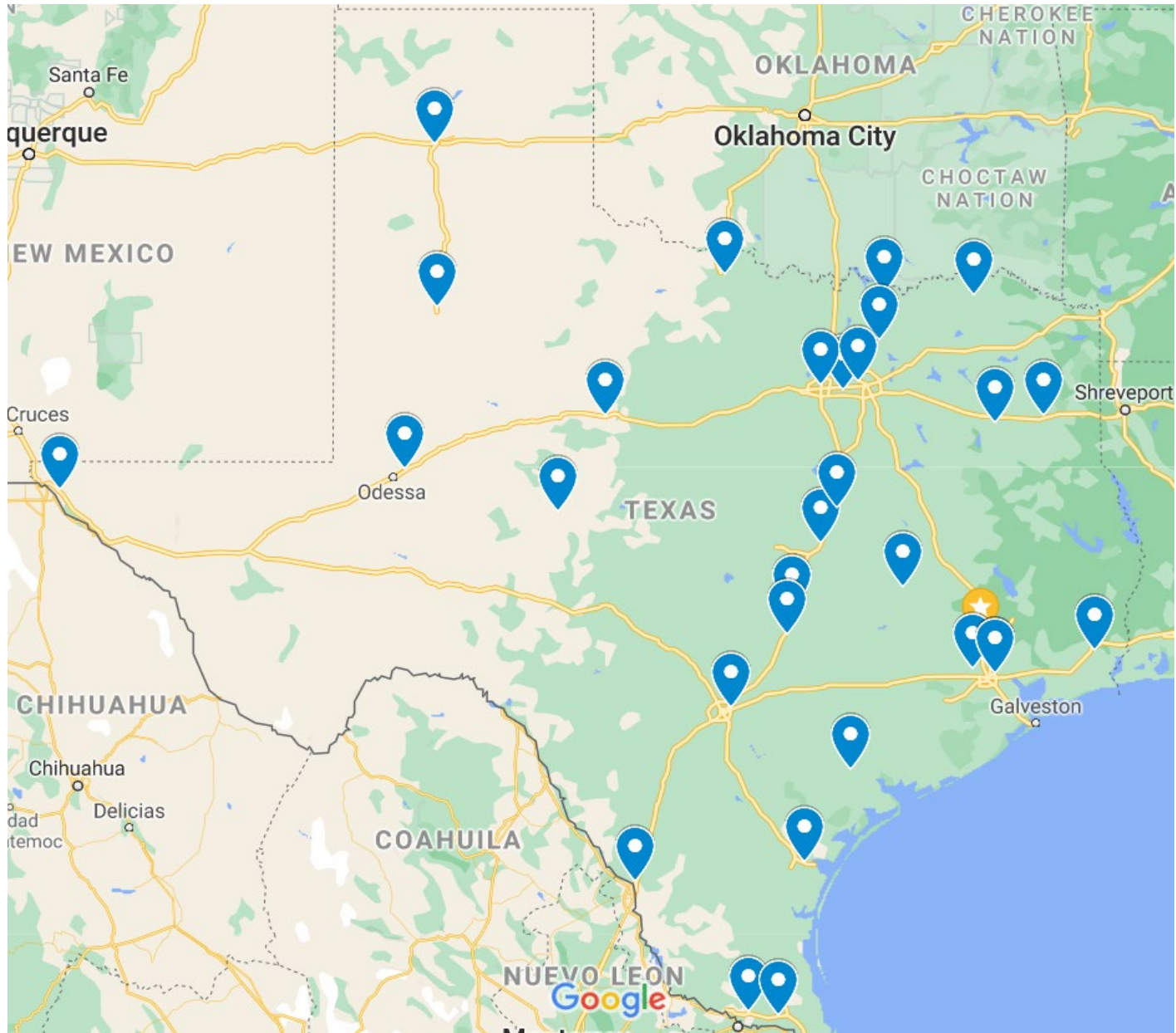

Medina Valley Independent School District

Agenda Item Memorandum

To: MVISD Board of Trustees

Date: 02/07/2024

RE: Consider approving the purchase of new athletic uniforms for both middle schools.

The Board approval the Middle School Branding Guide created a need to purchase new middle school athletic uniforms for multiple sports with the branding guide logos and color schemes. The total cost (\$160,498) of this purchase has not been budgeted, a budget amendment is requested to fund this purchase. The Purchasing Department recommends the purchase with Game One utilizing the awarded contract #COG-2144B with The Equalis Group Cooperative which MVISD retains membership.

Administration recommends approval of the middle school athletic uniform purchase with Game One.

MVISD Board Policy CH (LOCAL) Purchasing and Acquisition



WWW.GAME-ONE.COM

QUOTE # D6083858-00

DATE: 2024-01-12

We are pleased to submit this quotation for your consideration. Should you place an order please reference the quote number below.

ACCOUNT: 138418

BILL TO: MEDINA VALLEY ISD 8449 F M 471 S CASTROVILLE TX 78009-9531 US	ATTN: Douglas Bull SHIP TO: Medina Valley Middle School Admin 8395 FM 471 S CASTROVILLE TX 78009-5314 US
---	---

QUOTE No	WAREHOUSE	DATE	PURCHASE ORDER	TERMS
D6083858 - 00	OD	2024-01-12		NET 30

ADDITIONAL COMMENTS:

- SOCCER WEB REF : D47536
RJJU1W Jersey
RJJU1W Jersey
RJUS1W Short
RJJU1A Jersey
RJJU1A Jersey
RJUS1A Short
RJJU2A Goalie Jersey
XC/TRACK WEB REF : 9E1872
RJTJ1W Jersey
RJTS1W Short
RJTS1A Jersey
RJTJ1A Short
TENNIS
510000 Men's Shirt
414600 Men's Short
560000 Women's Shirt
401200 Women's Short
NAVY SHIRT WITH ORANGE LETTERING
NAVY SHORT WITH ORANGE LETTERING

Style Code	LINE	ITEM	DESCRIPTION	ORDERED	WAREHOUSE	PRICE	UOM	TOTAL PRICE
	1	CBADGE-V01-00	RJJU1W Soccer Jrsv	60	MF	25.00	EA	1,500.00
	2	CBADGE-V02-00	RJJU1W Soccer Jrsv	60	MF	25.00	EA	1,500.00
	3	CBADGE-V03-00	RJUS1W Soccer Short	60	MF	25.00	EA	1,500.00
	4	CBADGE-V04-00	RJJU1A Soccer Jrsv	60	MF	25.00	EA	1,500.00
	5	CBADGE-V05-00	RJJU1A Soccer Jrsv	60	MF	25.00	EA	1,500.00
	6	CBADGE-V06-00	RJUS1A Soccer Shorts	60	MF	25.00	EA	1,500.00
	7	CBADGE-V07-00	RJJU2A Goalie Jrsv	16	MF	33.00	EA	528.00
	8	CBADGE-V08-00	RJTJ1W Track Jrsv	150	MF	28.00	EA	4,200.00
								197

Style Code	LINE	ITEM	DESCRIPTION	ORDERED	WAREHOUSE	PRICE	UOM	TOTAL PRICE
	9	CBADGE-V09-00	RJTS1W Track Short	150	MF	33.00	EA	4,950.00
	10	CBADGE-V10-00	RJTS1A Track Jrsy	150	MF	28.00	EA	4,200.00
	11	CBADGE V11 00	RJTJ1A Track Shorts	150	MF	33.00	EA	4,950.00
	12	CBADGE V12 00	510000 M's Shirt	40	MF	13.00	EA	520.00
	13	CBADGE V13 00	414600 M's Short	40	MF	18.00	EA	720.00
	14	CBADGE V14 00	560000 W's Shirt	40	MF	13.00	EA	520.00
	15	CBADGE V15 00	401200 W's Short	40	MF	18.00	EA	720.00

Prepared By: haleys

Quoted prices reflect our wholesale, discounted prices for payment by cash, check, or net terms only. Quote does not include freight charges unless specified. Prices quoted are subject to change based on vendor pricing.

Merchandise Total	30,308.00
Tax	0.00
Shipping & Handling	1,910.50
Total	32,218.50

THIS IS **NOT** A BILL. **DO NOT** PAY FROM THIS DOCUMENT.



WWW.GAME-ONE.COM

QUOTE # D6083835-00

DATE: 2024-01-12

We are pleased to submit this quotation for your consideration. Should you place an order please reference the quote number below.

ACCOUNT: 138418

BILL TO: MEDINA VALLEY ISD 8449 F M 471 S CASTROVILLE TX 78009-9531 US	ATTN: Douglas Bull SHIP TO: Medina Valley Middle School Admin 8395 FM 471 S CASTROVILLE TX 78009-5314 US
---	---

QUOTE No	WAREHOUSE	DATE	PURCHASE ORDER	TERMS
D6083835 - 00	OD	2024-01-12		NET 30

ADDITIONAL COMMENTS:

- SOCCER WEB REF: 53B3A0
RJJU1W Jersey
RJJU1W Jersey
RJUS1W Short
RJJU1A Jersey
RJJU1A Jersey
RJUS1A Short
RJJU2A Goalie Jersey
XC/TRACK WEB REF: A6667E
RJTJ1W Jersey
RJTS1W Short
RJTS1A Jersey
RJTJ1A Short
TENNIS Shirts
510000 Men's Shirt
414600 Men's Short
560000 Women's Shirt
401200 Women's Short
GRAPHITE SHIRT WITH ORANGE LETTERING
GRAPHITE SHORT WITH ORANGE LETTERING

Style Code	LINE	ITEM	DESCRIPTION	ORDERED	WAREHOUSE	PRICE	UOM	TOTAL PRICE
	1	CBADGE-V01-00	RJJU1W Soccer Jersey	60	MF	25.00	EA	1,500.00
	2	CBADGE-V02-00	RJJU1W Soccer Jrsy	60	MF	25.00	EA	1,500.00
	3	CBADGE-V03-00	RJUS1W Soccer Shorts	60	MF	25.00	EA	1,500.00
	4	CBADGE-V04-00	RJJU1A Soccer Jrsy	60	MF	25.00	EA	1,500.00
	5	CBADGE-V05-00	RJJU1A Soccer Jrsy	60	MF	25.00	EA	1,500.00
	6	CBADGE-V06-00	RJUS1A Soccer Shorts	60	MF	25.00	EA	1,500.00
	7	CBADGE-V07-00	RJJU2A Goalie Jrsy	16	MF	33.00	EA	528.00
	8	CBADGE-V08-00	RJTJ1W Track Jrsy	150	MF	28.00	EA	4,200.00
								199

Style Code	LINE	ITEM	DESCRIPTION	ORDERED	WAREHOUSE	PRICE	UOM	TOTAL PRICE
	9	CBADGE-V09-00	RJTS1W Track Shorts	150	MF	33.00	EA	4,950.00
	10	CBADGE-V10-00	RJTS1A Track Jrsy	150	MF	28.00	EA	4,200.00
	11	CBADGE V11 00	RJTJ1A Track Short	150	MF	33.00	EA	4,950.00
	12	CBADGE V12 00	510000 M's Tennis Shirt	40	MF	13.00	EA	520.00
	13	CBADGE V13 00	414600 M's Tennis Short	40	MF	18.00	EA	720.00
	14	CBADGE V14 00	560000 W's Tennis Shirt	40	MF	13.00	EA	520.00
	15	CBADGE V15 00	401200 W's Tennis Short	40	MF	18.00	EA	720.00

Prepared By: haleys

Quoted prices reflect our wholesale, discounted prices for payment by cash, check, or net terms only. Quote does not include freight charges unless specified. Prices quoted are subject to change based on vendor pricing.

Merchandise Total	30,308.00
Tax	0.00
Shipping & Handling	1,910.50
Total	32,218.50

THIS IS **NOT** A BILL. **DO NOT** PAY FROM THIS DOCUMENT.



WWW.GAME-ONE.COM

QUOTE # D6083806-00

DATE: 2024-01-12

We are pleased to submit this quotation for your consideration.
Should you place an order please reference the quote number below.

ACCOUNT: 138418

Table with 2 columns: BILL TO (MEDINA VALLEY ISD, 8449 F M 471 S, CASTROVILLE TX 78009-9531, US) and ATTN: Douglas Bull, SHIP TO (Medina Valley Middle School Admin, 8395 FM 471 S, CASTROVILLE TX 78009-5314, US)

Summary table with columns: QUOTE No (D6083806 - 00), WAREHOUSE (OD), DATE (2024-01-12), PURCHASE ORDER, TERMS (NET 30)

ADDITIONAL COMMENTS:

- FOOTBALL WEB REF: A0C13F
RJFJ2A Jersey
689S (CHARCOAL) Pants
712 (CHARCOAL) Practice Jersey
VOLLEYBALL WEB REF: A0C13F
RJVVJ2W Jersey's
RJTS1W Shorts
BASKETBALL WEB REF: E01AA4
RJKJ1W Jersey
RJKR5W Short
RJKJ1A Jersey
RJKR7A Short

Main item table with columns: Style Code, LINE, ITEM, DESCRIPTION, ORDERED, WAREHOUSE, PRICE, UOM, TOTAL PRICE. Contains 9 rows of items including jerseys, pants, and shorts.

Prepared By: haleys

Quoted prices reflect our wholesale, discounted prices for payment by cash, check, or net terms only. Quote does not include freight charges unless specified. Prices quoted are subject to change based on vendor pricing.

Merchandise Total	46,120.00
Tax	0.00
Shipping & Handling	1,910.50
Total	48,030.50

THIS IS **NOT** A BILL. **DO NOT** PAY FROM THIS DOCUMENT.



WWW.GAME-ONE.COM

QUOTE # D6083840-00

DATE: 2024-01-12

We are pleased to submit this quotation for your consideration.
Should you place an order please reference the quote number below.

ACCOUNT: 138418

Table with 2 columns: BILL TO (MEDINA VALLEY ISD, 8449 F M 471 S, CASTROVILLE TX 78009-9531, US) and SHIP TO (Medina Valley Middle School Admin, 8395 FM 471 S, CASTROVILLE TX 78009-5314, US)

Summary table with columns: QUOTE No (D6083840 - 00), WAREHOUSE (OD), DATE (2024-01-12), PURCHASE ORDER, TERMS (NET 30)

ADDITIONAL COMMENTS:

- FOOTBALL WEB REF : DE6634
RJFJ2A Jersey's
689S (NAVY) Pants
712 (NAVY) Practice Jersey
VOLLEYBALL WEB REF : DE6634
RJVJ2W Jersey's
RJTS1W Shorts
BASKETBALL WEB REF : 9E7628
RJKJ1W Jersey
RJKR5W Shorts
RJKJ1A Jersey
RJKR7A Shorts

Main item table with columns: Style Code, LINE, ITEM, DESCRIPTION, ORDERED, WAREHOUSE, PRICE, UOM, TOTAL PRICE. Contains 9 rows of items including jerseys, pants, and shorts.

Prepared By: haleys

Quoted prices reflect our wholesale, discounted prices for payment by cash, check, or net terms only. Quote does not include freight charges unless specified. Prices quoted are subject to change based on vendor pricing.

Merchandise Total	46,120.00
Tax	0.00
Shipping & Handling	1,910.50
Total	48,030.50

THIS IS **NOT** A BILL. **DO NOT** PAY FROM THIS DOCUMENT.

Medina Valley Independent School District

Agenda Item Memorandum

To: MVISD Board of Trustees

Date: February, 12,2024

RE: Consider approving the purchase of Capital Outlay – Band Instruments

The fast growth of our district over the last few years has resulted in our program numbers exceeding the capital outlay plan that was in place to purchase and replace our instruments. In order to have enough instruments for all students to participate in our Band Program over the next few years, the Fine Arts Department is requesting approval to purchase Concert Tubas, Marching Sousaphones (marching tubas), and Percussion equipment. Purchasing the instruments now is necessary due to the timeline it takes to receive instruments for a total of \$137,674.89 which is not budgeted for. A budget amendment is requested to fund this project. The Purchasing Department recommends the purchase with Taylor Music utilizing the awarded contract #21027 with the Region 20 Purchasing Cooperative which MVISD retains membership.

The Fine Arts department will develop and implement policies to ensure that future purchases for growth and replacement are part of the regular budgeting process for a fast growth district.

Administration recommends approval of the Band Instruments from Taylor Music.

MVISD Board Policy CH (LOCAL) Purchasing and Acquisition

Type of Instrument	Brand	Model Number	Quantity	High School Music		Washington Music		Taylor Music		Steve Weiss	
				Individual Price	Extention	Individual Price	Extention	Individual Price	Extention	Individual Price	Extention
Sousaphone w/case	Yamaha	YSH-411WC	5	\$6,955.00	\$34,775.00	\$8,348.00	\$41,740.00	\$6,888.00	\$34,440.00	\$0.00	No Bid
Tuba w/Case	Yamaha	YBB-621	5	\$7,229.00	\$36,145.00	\$7,350.10	\$36,750.50	\$7,333.00	\$36,665.00	\$0.00	No Bid
Marimba	Yamaha	YMRD-2900A	4	\$9,137.00	\$36,548.00	\$9,299.15	\$37,196.60	\$9,099.00	\$36,396.00	\$9,330.00	\$37,320.00
Vibraphone	Yamaha	YVRD-2700	3	\$5,172.00	\$15,516.00	\$5,265.60	\$15,796.80	\$5,199.00	\$15,597.00	\$5,285.00	\$15,855.00
Marching Snare Drum	Pearl	FFXCC 1212/A103	2	\$975.00	\$1,950.00	\$977.00	\$1,954.00	\$944.00	\$1,888.00	\$965.00	\$1,930.00
Marching Tenor Drums	Pearl	PMTCCS6802134/A103	2	\$2,529.00	\$5,058.00	\$2,591.30	\$5,182.60	\$2,484.00	\$4,968.00	\$2,585.00	\$5,170.00
Single Tenor Drum (Flub)	Pearl	PMTCC148ST/A103	3	\$699.00	\$2,097.00	\$704.85	\$2,114.55	\$696.00	\$2,088.00	\$1,035.00	\$3,105.00
Marching Snare Drum Carrier	Pearl	CXS2	5	\$339.00	\$1,695.00	\$316.65	\$1,583.25	\$299.00	\$1,495.00	\$304.00	\$1,520.00
Marching Tenor Drum Carrier	Pearl	CXT2	2	\$387.00	\$774.00	\$366.65	\$733.30	\$349.00	\$698.00	\$352.00	\$704.00
Marching Snare Drum Stands	Pearl	MSS3000	5	\$219.00	\$1,095.00	\$198.95	\$994.75	\$188.00	\$940.00	\$191.00	\$955.00
Marching Tenor Drum Stands	Pearl	MTS3000	2	\$241.00	\$482.00	\$221.90	\$443.80	\$211.00	\$422.00	\$213.00	\$426.00
Marching Snare Drum Covers	Pearl	MDCG14	5	\$82.00	\$410.00	\$58.35	\$291.75	\$55.99	\$279.95	\$56.00	\$280.00
Marching Tenor Drum Covers	Pearl	MDCG0234	2	\$99.00	\$198.00	\$77.10	\$154.20	\$73.99	\$147.98	\$74.00	\$148.00
Marching Snare Case	Pearl	PD1412	5	\$139.00	\$695.00	\$113.55	\$567.75	\$111.00	\$555.00	\$109.00	\$545.00
Marching Tenor Case	Pearl	PD8004	2	\$269.00	\$538.00	\$223.95	\$447.90	\$212.00	\$424.00	\$215.00	\$430.00
Marmimba Drop Cover	Yamaha	YM-2900DC	4	\$165.00	\$660.00	\$0.00	No Bid	\$109.99	\$439.96	\$0.00	No Bid
Vibraphone Drop Cover	Yamaha	YV2700DC	3	\$127.00	\$381.00	\$0.00	No Bid	\$77.00	\$231.00	\$0.00	No Bid
					\$139,017.00		\$145,951.75		\$137,674.89		\$68,388.00

Customer Information

Juan Rodriguez	Friday, February 02, 2024
Medina Valley ISD	FOB: Destination (Free shipping/freight)
8365 FM 471 South	Mary McKinney, School Bid Sales
Castroville, TX 78009	Terms: 0% Net 30 (no "P" cards)
juan.rodriguez@mvisd.org	Prices firm for 60 days (longer upon request)
Region 2013 Purchasing Cooperative #21027B Expires 4/30/2024	ETA's subject to change per factory availability

Thank you for the opportunity to submit the following quotation:

Item/Description	Brand	Model	Quantity	Unit	Total	ETA
Sousaphone w/case	Yamaha	YSH-411WC (Lacquer)	5	\$ 6,888.00	\$ 34,440.00	November 2024
Tuba w/Case 3/4 size, 4 piston valve	Yamaha	YBB-621 (includes case)	5	\$ 7,333.00	\$ 36,665.00	June 2024
Alternate Tuba w/case 4/4 size, 4 rotary valves	Yamaha	YBB-641 (includes case)	5	\$ 7,333.00		In stock
Marimba	Yamaha	YMRD-2900A	4	\$ 9,099.00	\$ 36,396.00	August 2024
Optional Marimba Drop Cover	Yamaha	YM-2900DC	4	\$ 109.99	\$ 439.96	Per factory
Vibraphone, silver bars	Yamaha	YVRD-2700MS (no motor)	3	\$ 5,199.00	\$ 15,597.00	May 2024
Optional Vibe Drop Cover	Yamaha	YV2700DC	3	\$ 77.00	\$ 231.00	In stock 15-30 days
Marching Snare Drum 14"x12"	Pearl	FFXCC1412/A103 (Piano Black)	2	\$ 944.00	\$ 1,888.00	In stock 15-30 days
Marching Tenor Drums	Pearl	PMTCCS6802134/A103 (Piano Black)	2	\$ 2,484.00	\$ 4,968.00	May/June 2024
Single Tenor Drum (Flub)	Pearl	PMTCC1408ST/A103 (Piano Black)	3	\$ 696.00	\$ 2,088.00	Special Order Item 180+ days
Marching Snare Drum Carrier	Pearl	CXS2	5	\$ 299.00	\$ 1,495.00	In stock 15-30 days
Marching Tenor Drum Carrier	Pearl	CXT2	2	\$ 349.00	\$ 698.00	In stock 15-30 days
Marching Snare Drum Stands	Pearl	MSS3000	5	\$ 188.00	\$ 940.00	In stock 15-30 days
Marching Tenor Drum Stands	Pearl	MTS3000	2	\$ 211.00	\$ 422.00	In stock 15-30 days
Marching Snare Drum Covers	Pearl	MDCG14	5	\$ 55.99	\$ 279.95	In stock 15-30 days
Marching Tenor Drum Covers	Pearl	MDCG0234	2	\$ 73.99	\$ 147.98	In stock 15-30 days
Marching Snare Case	Pearl	PD1412	5	\$ 111.00	\$ 555.00	In stock 15-30 days
Marching Tenor Case	Pearl	PD8004	2	\$ 212.00	\$ 424.00	In stock 15-30 days

\$ 137,674.89

MVISD Vendor # 20001129

HIGH SCHOOL MUSIC SERVICE

2121 nw military hwy san antonio, tx 78213 (210) 349-2775(800) 275-4767 fax(210)349-3797

MVISD Vendor #10001876

Type text here

LETRHEAD

2-Feb-24

TO: Juan Rodriguez, Fine arts
Medina Valley I S D

Here is the information that you requested.

<u>#</u>	<u>Make / Model</u>	<u>Instrument</u>	<u>Price Each</u>	<u>Total</u>
5	Yamaha YSH411WC	Sousaphone - Lacquer	\$6,955.00	\$34,775.00
5	Yamaha YBB621	3/4 Tuba w/Case 4 Valves	\$7,229.00	\$36,145.00
4	Yamaha YMRD2900A	Marimba 4.5 Octave Multi-Frame II	\$9,137.00	\$36,548.00
4	Yamaha TAC YM2900DC	Drop Cover for YMRD2900A	\$165.00	\$660.00
3	Yamaha YVRD2700MS	Vibraphone 3 Octave Multi-Frame II	\$5,172.00	\$15,516.00
3	Yamaha TAC YV2700DC	Drop Cover for YVRD2700	\$127.00	\$381.00
2	Pearl FFXCC1412/A103	Marching Snare Drum - Piano Black	\$975.00	\$1,950.00
2	Pearl PMTCC680234/A103	Marching Tenor Drums - Piano Black	\$2,529.00	\$5,058.00
3	Pearl PMTCC1413ST/A103	Tenor Drum - Piano Black	\$699.00	\$2,097.00
5	Pearl CXS2	Snare Drum Carrier	\$339.00	\$1,695.00
2	Pearl CXT2	Tenor Drum Carrier	\$387.00	\$774.00
2	Pearl MTS3000	Tenor Drum Stands	\$241.00	\$482.00
5	Pearl MSS3000	Snare Drum Stands	\$219.00	\$1,095.00
5	Pearl MDCG14	Snare Drum Covers	\$82.00	\$410.00
2	Pearl MDCG0234	Tenor Drum Covers	\$99.00	\$198.00
5	Pearl PD1412	Marching Snare Drum Case	\$139.00	\$695.00
2	Pearl PD8004	Marching Tenor Case	\$269.00	\$538.00
				<u>\$139,017.00</u>

Sincerely,

Greg Watkins
H S M S, Inc.



WASHINGTON MUSIC CENTER

Washington Music Sales Center, Inc.

D/B/A Washington Music Center

11151 Veirs Mill Road Wheaton, MD 20902

DUNS No.: 02-429-1544 Employer ID: 53-0259612

Phone: 301-946-8808 Fax: 301-946-0487

SALES QUOTE

Page: 1
Quote No.: SQOP021892
Quote Date: 02/06/24
Valid Until: 04/06/24
Customer No.: P036204

Quote

To: MEDINA VALLEY ISD
8449 F M 471 S
CASTROVILLE, TX 78009
JUAN CARLOS RODRIGUEZ
Phone: (830) 931-2243

Salesperson: Trey Smith
FOB: Destination

Qty.	Product Description	Unit Price	Total Price
5	YAMAHA YSH-411SWC *BRASS SOUSAPHONE; KEY OF BBB; SILVER-PLATED; 3 FRONT ACTION	8,348.00	41,740.00
5	YAMAHA YBB-621 PROFESSIONAL TUBA; KEY OF BBB; 3/4 SIZE; 4 FRONT ACTION MONEL	7,350.10	36,750.50
4	YAMAHA YMRD-2900A 4.5 OCTAVE INTERMEDIATE ACOUSTALON MULTI-FRAME II MARIMBA; F21-C76; 1-1/2"-2-	9,299.15	37,196.60
3	YAMAHA YVRD-2700MS 3 OCTAVE MULTI-FRAME II VIBRAPHONE; MATTE SILVER BARS & SILVER RESONATOR	5,265.60	15,796.80
2	PEARL DRUMS FFCC1412/A103 14X12 CARBON CORE MARCHING SNARE DRUM - PIANO BLACK	977.00	1,954.00
2	PEARL DRUMS PMTCC680234/A103 6+8+10+12+13+14 CHAMPIONSHIP MARCHING TOM SET, SONIC CUT	2,591.30	5,182.60
3	PEARL DRUMS PMTCC1413ST/A103 14X13 CARBONCORE SONIC CUT SINGLE TENOR, ALUMINUM	704.85	2,114.55
2	PEARL DRUMS CXS2 CX AIRFRAME SNARE DRUM CARRIER	316.65	633.30
5	PEARL DRUMS CXT2 TENOR CX AIRFRAME CARRIER	366.65	1,833.25
2	PEARL DRUMS MSS3000 ADVANCED SYSTEM MARCHING SNARE STAND	198.95	397.90
5	PEARL DRUMS MTS3000 ADVANCED SYSTEM MARCHING TENOR STAND	221.90	1,109.50
5	PEARL DRUMS MDCG14 14 SNARE COVER BAG CUT-OUT...	58.35	291.75
2	PEARL DRUMS MDCG0234 QUAD COVER (0234) W/STICK BAG CUT-OUT...	77.10	154.20
5	PEARL DRUMS PD1412 14"X12" SNARE DRUM CASE, NO FOAM	113.55	567.75
2	PEARL DRUMS PD8004 QUAD/QUINT/SEXTET CASE, NO FOAM	223.95	447.90

WMC ** QUOTED PRICES REFLECT PAYMENT

BY CHECK OR EFT TO AVOID ADDITIONAL 3% CREDIT CARD PROCESSING FEE.

*** FREE SHIPPING ON ORDERS 250.00 & UP ***

Conditions: Washington Music Center retains title to all equipment until payment is received in full. Customized systems require deposit. Payments received after due date are subject to late charges. Returns are subject to a 20% restocking fee. All returns must include original packaging, no returns after 30 days. Returns will not be accepted without a return authorization number. Warranties are as per manufacturers written limited warranty.

Acceptance of Quotation: By signing below I and/or the above listed company agree to purchase the listed equipment from Washington Music Center on the terms and conditions set forth in this quotation. Freight charges may be added.

Accepted by: _____ Date: _____

Subtotal: 146,170.60
Total Sales Tax: 12,059.08

Total Amount 158,229.68

Steve Weiss Music Inc.
 2324 Wyandotte Rd
 Willow Grove PA 19090
 United States
 (215) 659-0100
 ph: (888) 659-3477
 fx: (215) 659-1170



BuyBoard 712-23
 MVISD Vendor #10011291

Quote #	QTE42762
Date	2/1/2024
Expires	4/1/2024

Quote

Bill To

Medina Valley ISD
 Accounts Payable
 8449 FM 471 South
 Castroville TX 78009

Ship To

Medina Valley ISD - Receiving
 Music Dept.
 8752 FM 471 South
 La Coste TX 78039

Cust. No.	Requested By	Ref. No.	Terms	Shipping Method	Created by
470629	Juan Carlos Rodriguez		Net 30	STD	Jake Cherwony

Notes

** FREE SHIPPING **

Quantity	Item	Options	Unit Price	Extended
4	YAM-YMRD2900A Yamaha Acoustalon 4.5 Octave Marimba w/ Multi-Frame II (NO COVER)		\$9,330.00	\$37,320.00
3	YAM-YVRD2700MS Yamaha 3 Octave Studio Vibe, Silver, w/ Multi-Frame II (No Cover) (No Motor)		\$5,285.00	\$15,855.00
2	PEA-FFXCC1412/A103 Pearl Championship CarbonCore Marching Snare, 14x12 #103 Piano Black Lacquer		\$965.00	\$1,930.00
2	PEA-PMTCCS680234/A103 Pearl Championship Maple CarbonCore Sextets -6,8,10,12,13,14 Piano Black Laquer		\$2,585.00	\$5,170.00
3	PEA-PMTCC148ST/A103 Pearl Championship Carbon Core Single Tenor, 14"+8" w/ Mounts for CXS1 - 103 Piano Black		\$1,035.00	\$3,105.00
2	PEA-CXS-2 Pearl CX Air Frame Snare Drum Carrier		\$304.00	\$608.00
5	PEA-CXT-2 Pearl CX Air Frame Tenor Carrier		\$352.00	\$1,760.00
2	PEA-MSS3000 Pearl Marching Snare Drum Stand (Advanced)		\$191.00	\$382.00
5	PEA-MTS3000 Pearl Marching Tenor Stand (Advanced)		\$213.00	\$1,065.00
5	PEA-MDCG14 Pearl Marching Snare Drum Cover, Grey - 14		\$56.00	\$280.00
2	PEA-MDCG0234 Pearl Marching Quad/Quint Cover, Grey - 0234		\$74.00	\$148.00
5	PEA-PD1412 Pearl Marching Snare Drum Case, No Foam (Fits 13" or 14" Drums)		\$109.00	\$545.00

Steve Weiss Music Inc.
2324 Wyandotte Rd
Willow Grove PA 19090
United States
(215) 659-0100
ph: (888) 659-3477
fx: (215) 659-1170



Quantity	Item	Options	Unit Price	Extended
2	PEA-PD8004 Pearl Marching Tenor Case - No Foam Fits All Configurations		\$215.00	\$430.00

Subtotal \$68,598.00
Shipping \$0.00
Tax Total \$0.00
Total \$68,598.00

Medina Valley Independent School District

Agenda Item Memorandum

To: MVIDS Board of Trustees

Date: February 12, 2024

RE: Consider approving Purchase for Cafeteria Furniture for Medina Valley Middle School

As part of the Child Nutrition (fund 240) excess net cash resource spend down plan, as approved by Texas Department of Agriculture (TDA) on April 11, 2023, monies were budgeted for cafeteria furniture to provide additional seating in the current space.

The Edu-Source Corp in the amount of \$111,853.67.

240 E 35 6399 00 881 0 99 0 01 - 65% of the spend totaling \$72,704.89 (*budgeted*)

199 E xx xxxx xx xxx x xx x xx - 35% of the spend totaling \$39,148.78, a budget amendment is requested to fund this portion.

These cafeteria tables will be installed at Medina Valley Middle School providing 442 total seats. Of those seats 22 are ADA seats. These tables have stool seating and will provide the students with defined seating and some independence in their space.

We reached out to three companies for quotes, two responded. Of the two, Edu-Source Corp provided all requested items according to specs and they were the least expensive.

Recommendation: Cafeteria table purchase for Medina Valley Middle School to be awarded to The Edu-Source Co-op in the amount of \$111,853.67.

Choice Partners Co-op – Cafeteria Trades 23/019TP

(expires 02.29.2024)

MVIDS Board Policy CH (LOCAL) Purchasing and Acquisition

MEDINA VALLEY ISD MEDINA VALLEY MS
 8395 FM 471 SOUTH
 CASTROVILLE TX 78009

DATE: 2/12/2024

QUOTE

Qty	Item	Spec/Size	School Unit Price	School Extended Price
CHAIRS				
22	CH1 - EIS MTO-CHMNS3	CHAIRS + STOOLS- STANDARD HEIGHT CHAIR 4 LEG BASE NOTCH BACK FREESTANDING CHAIR ASSEMBLY. LAINATE SHELL: SEAT AND BACK: STANDARD LAMINATE VERTICAL GRAIN DIRECTION ON REINFORCED CHROME FRAME STACKABLE AND OVERCAP NYLON GLIDE	\$172.91	\$3,804.02
SICO - MOBILE FOLDING FURNITURE				
11	PRESIDENT TABLE WITH 12 STOOLS LINE ITEM #250	12"L X 30"H WITH 12 STOOLS INCLUDES: 18MM MDF CORE TABLETOP, ARMOR EDGE, COMFORT STYLE STOOL DESIN WITH ACCENT GUARD, EXCLUSIVE STRUT ASSIST, CENTER GRAVITY LOCK BAR COLOR: TBD CHROME LEGS	\$2,440.00	\$26,840.00
5	PRESIDENT TABLE ADA WITH 8 STOOLS LINE ITEM # 209	12"L X 30"H WITH 8 STOOLS INCLUDES: 18MM MDF CORE TABLETOP, ARMOR EDGE, COMFORT STYLE STOOL DESIN WITH ACCENT GUARD, EXCLUSIVE STRUT ASSIST, CENTER GRAVITY LOCK BAR COLOR: TBD - CHROME LEGS	\$2,037.33	\$10,186.65
14	GRADUATE TABLE WITH 8 STOOLS LINE ITEM# 241	54"L X 60 X 30"H WITH 8 STOOLS INCLUDES: 18MM MDF CORE TABLETOP, ARMOR EDGE, COMFORT STYLE STOOL DESIN WITH ACCENT GUARD, EXCLUSIVE STRUT ASSIST, CENTER GRAVITY LOCK BAR COLOR: TBD CHROME LEGS	\$2,060.00	\$28,840.00
6	COMMUNICATOR WITH 12 STOOLS LINE I TEM # 240	42"W X 10 X 30"H WITH 12 STOOLS INCLUDES: 18MM MDF CORE TABLETOP, ARMOR EDGE, COMFORT STYLE STOOL DESIN WITH ACCENT GUARD, EXCLUSIVE STRUT ASSIST, CENTER GRAVITY LOCK BAR COLOR: TBD CHROME LEGS	\$2,895.00	\$17,370.00
8	DIRECTOR TABLE WITH 8 STOOLS	DIRECTOR TABLE WITH 8 STOOLS	\$2,016.00	\$16,128.00

THE EDU-SOURCE CORPORATION
 PO BOX 691948 SAN ANTONIO TX 78269
 PHONE (800) 258-8559 or 210-699-4268

LINE ITEM #238

INCLUDES: 18MM MDF CORE TABLETOP, ARMOR EDGE, COMFORT

STYLE STOOL DESIN WITH ACCENT GUARD, EXCLUSIVE STRUT

ASSIST, CENTER GRAVITY LOCK BAR

COLOR: TBD - CHROME LEGS

PRODUCT TOTAL		\$103,168.67
----------------------	--	---------------------

FIELD SERVICE

DELIVERY		\$5,150.00
----------	--	-------------------

35	INSTALLATION - HOURLY RATE	INCLUDES DELIVERY, ASSEMBLY, PLACEMENT AND REMOVAL OF ALL DEBRIS	\$101.00	\$3,535.00
----	----------------------------	--	----------	-------------------

CONTRACT TOTAL		\$111,853.67
-----------------------	--	---------------------

CHOICE PARTNERS CAFETERIA TRADES 23/019TP ADDENDUM 1

MVISD Quote Summary



The MVISD Quote Summary sheet is to be used for purchases that exceed \$10,000 but are less than \$50,000. In the spaces below, the end user is to provide all the information necessary for the MVISD Finance Department to review.

Quote Information

Description: Cafeteria Furniture

Date: 2.15.24

Campus/Dept: MV Middle School

Contact: Tiffany Eckenrod

Supplier Information

Vendor #1

Company Name The Edu-Source Corporation
 City/State San Antonio, TX
 Contact Person Alex Rios
 Phone 210.699.4268
 Email alex@edusourcecorp.com
 Comments all items quoted ; lowest price with all included

Vendor #2

Company Name Palmer Hamilton
 City/State Elkhorn, WI
 Contact Person Pamela Gannon
 Phone 800.788.1028
 Email PGannon@palmerhamilton.com
 Comments _____

Vendor #3

Company Name Radius Design Works
 City/State _____
 Contact Person _____
 Phone _____
 Email c_berry@radiusdesignworks.com
 Comments No Bid/ No response

Quote Responses

Item/Service Description	Quantity
1 Please see typed quote summary for item list	1
2 Delivery	1
3 Installation	1
4	
5	
6	
7	
8	
9	
10	

The Edu-Source Corporation

	Unit Price	Total Per Item
1	\$ 103,168.67	\$ 103,168.67
2	\$ 5,150.00	\$ 5,150.00
3	\$ 3,535.00	\$ 3,535.00
4	\$ -	\$ -
5	\$ -	\$ -
6	\$ -	\$ -
7	\$ -	\$ -
8	\$ -	\$ -
9	\$ -	\$ -
10	\$ -	\$ -
TOTAL	\$	111,853.67

Palmer Hamilton

	Unit Price	Total Per Item
1	\$ 114,944.80	\$ 114,944.80
2	\$ 6,635.11	\$ 6,635.11
3	\$ 5,797.15	\$ 5,797.15
4	\$ -	\$ -
5	\$ -	\$ -
6	\$ -	\$ -
7	\$ -	\$ -
8	\$ -	\$ -
9	\$ -	\$ -
10	\$ -	\$ -
TOTAL	\$	127,377.06

Radius Design Works

	Unit Price	Total Per Item
1	\$ -	\$ -
2	\$ -	\$ -
3	\$ -	\$ -
4	\$ -	\$ -
5	\$ -	\$ -
6	\$ -	\$ -
7	\$ -	\$ -
8	\$ -	\$ -
9	\$ -	\$ -
10	\$ -	\$ -
TOTAL	\$	-

Award Information

Recommended Vendor(s): The Edu-Source Corporation

Award Amount \$ 111,853.67

Reason for Award:

Choice Partners Co-op Cafeteria Trades 23/019TP Addendum 1. Meets specifications for seating needs. These tables can be easily moved for different layouts and for cleaning. The tables fold up and roll very easily, this is helpful when the floor needs to be open, such as for floor polishing and event holding. These tables are the least expensive per seat and meet specs.

Medina Valley Independent School District

Agenda Item Memorandum

To: MVISD Board of Trustees

Date: February 26, 2024

RE: Consider approving contract with Zayo for Wide Area Network construction

The wide area network is the connection between MVISD's central data center and the outlying campuses. Currently we are using AT&T's commercial network for these connections, but Zayo will provide us with a minimum of 10x the speed on dedicated fiber at half the cost.

The District conducted a category 1 erate bid in November for construction of a wide area network (fiber) to serve all of the MVISD campuses with a minimum of 10gbps, upgradeable to 40gbps. E-rate bids are conducted through the district's e-rate consultants, Kellogg and Sovereign, who ensure compliance with all state and federal rules regarding e-rate bids. Zayo was selected as the winner of the bid.

- The District will not be billed for construction until all circuits are complete, and we have received a funding commitment letter from USAC.
- The District's portion of the construction costs (\$1,994,563) is \$398,912.60 which we will split into four annual payments of \$99,728.15.
- The District's annual cost for these connections, pre-erate, will drop from \$76,129 to \$36,000, with 80% of that being refunded to the district (\$28,800) through the erate program.

MASTER CUSTOMER AGREEMENT

This Master Customer Agreement (“MCA”) is effective as of Month February Day 26 20 YR 24 (“Effective Date”) between Zayo Group, LLC, a Delaware limited liability company, with an address of 1821 30th Street, Unit A, Boulder, CO 80301 (collectively “Zayo” and each entity controlled by, controlling or under common control with Zayo, a “Zayo Affiliate”) and ~~(Insert Customer Name)~~ Medina Valley Independent School District, a ~~(Insert Country/State/Province/etc.)~~ Texas ~~(Insert corporation/limited liability company/partnership/ect.)~~ Public School District with an address of ~~(Insert Address)~~ 8449 FM 471 S., Castroville, TX 78009 (“Customer”). Zayo and Customer each may be referred to herein as a “Party” and collectively as the “Parties”.

ARTICLE 1 - GENERAL

1.1 Agreement Structure. This MCA provides general terms and conditions under which Customer may from time to time purchase access to and utilization of selected portions of the Zayo fiber network and associated infrastructure (“Access”) and certain related telecommunications and infrastructure services (“Services”) from Zayo. Terms and conditions that apply to Access and to each type of Service are set forth in customer schedules (each a “Customer Schedule”). Access and Services may also be referred to as offerings (“Offerings”) in the Customer Schedule and Customer Orders. This MCA, applicable Customer Schedules, and Customer Orders are collectively the “Agreement”. Any part of the Agreement may be entered into and performed by any Zayo Affiliate, including those authorized to provide Access or Services in any country or jurisdiction.

1.2 Orders for Access and/or Services. Customer may request that Zayo provide Access and/or Services by submitting a customer order in a form provided by Zayo (“Customer Order”). Customer is responsible for the accuracy of all information that it provides to Zayo. Customer Orders shall set forth the term, pricing, Access and Service type and location(s), monthly recurring charge (“MRC”), non-recurring charge (“NRC”) and any additional terms applicable to the Access and/or Services. All Customer Orders are subject to availability and acceptance by Zayo, and are governed by this Agreement.

1.3 Term. The term of each Customer Order shall commence on the Activation Date (as defined in the applicable Customer Schedule) for such Access and/or Service and continue for the period of time specified in that Customer Order. Thereafter, the term shall automatically renew for one year periods (collectively, the “Order Term”) until terminated by either Party upon at least 90 days written notice prior to the end of the Order Term. Customer is responsible for payment to Zayo for the Access and Services to be terminated through the date of termination. The term of the Agreement is coterminous with the longest Order Term hereunder.

1.4 Order of Precedence. In the event of an express conflict between terms in the Agreement, precedence will be given, as applicable, in the following order: (a) the Customer Order, but solely with respect to the Services covered by such Customer Order (b) the Customer Schedule, but solely with respect to the Services covered by such Customer Schedule, and (c) the MCA.

ARTICLE 2 - PAYMENT TERMS

2.1 Invoicing and Payment Terms. Zayo commences billing and Customer shall be liable for payment upon the Activation Date. Zayo will provide Customer with a monthly itemized invoice for the Access and Services together with all other charges due. Customer shall pay to Zayo all amounts due in full, without offset or reduction, within 30 days from the date of the invoice (“Due Date”). Invoice amounts not paid on or before the Due Date shall bear interest at the rate of one and one-half percent per month or the highest lawful rate, whichever is lower. Unless otherwise stated in the Agreement, Zayo invoices NRCs upon acceptance of a Customer Order.

2.2 Invoice Disputes. If Customer reasonably disputes any portion of an invoice, Customer shall timely pay all undisputed amounts and shall notify Zayo in writing and provide detailed documentation supporting its dispute by the Due Date or Customer’s right to any billing adjustment shall be waived. If the dispute is resolved against Customer, Customer shall pay such amounts due plus interest, as set forth in Section 2.1 above, from and after the Due Date.

2.3 Taxes and Other Fees and Surcharges. Excluding taxes based on Zayo’s net income, Customer shall be responsible for all Taxes (defined below) and Other Fees and Surcharges (defined below) arising in any jurisdiction imposed on or incident to the provision, sale or use of Access or Services, including but not limited to value added, consumption, sales, use, gross receipts, foreign withholding (which will be grossed up), excise, access and bypass (collectively “Taxes”) and any property, franchise, rights of way, license or permit, regulatory or other taxes, duties, fees, charges or surcharges (collectively “Other Fees and Surcharges”). Charges for Access and Services are exclusive of any Taxes and Other Fees and Surcharges. Taxes and Other Fees and Surcharges may be recovered through

imposition of a percentage surcharge on the charges for Access and Services to Customer. Customer may present Zayo with a valid exemption certificate (in a form reasonably acceptable to Zayo); Zayo will give effect thereto prospectively.

2.4 Portability. Customer may terminate an existing Service (the “**Original Service**”) and make a one-time request that such Service be replaced by a new Service (“**Replacement Service**”), and Customer will not incur any early termination liability with respect to the Original Service, as long as: (a) the Original Service is On-Net, (b) the Original Service has been in-service for at least twelve (12) months of the Order Term, and (c) Customer submits, and Zayo accepts, a Customer Order for the Replacement Service that complies with the requirements of this provision (the “**Replacement Customer Order**”). The Replacement Customer Order shall reflect (i) an Order Term of at least one (1) additional year beyond the expiration date of the Order Term for the Original Service, (ii) an MRC at least equal to the MRC of the Original Service and (iii) an NRC to implement the Replacement Service (which may include costs incurred but not recovered under the Original Service). Customer may not terminate the Original Service until commencement of the Replacement Service, and must provide Zayo at least thirty (30) days' written notice of disconnection prior to disconnection of the Original Service. Customer must pay all charges for the Original Service through the disconnection date. “On-Net” means any Service which connects two locations to which Zayo is already providing the same type of Service at the time of the Order and which is provisioned entirely on Zayo facilities and does not include any third party services or special construction.

ARTICLE 3 - DEFAULT

If Customer fails to make any payment due under the Agreement by the Due Date, and such failure continues for five days after receiving notice of the failure to make payment, or if a Party fails to cure any material breach of any term of the Agreement within 30 days of receiving notice of the breach from the other Party, then the non-breaching Party may: (a) terminate the Agreement in whole or in part and (b) subject to the liability limitations stated herein, pursue any available remedies at law or in equity.

ARTICLE 4 - LIABILITIES

4.1 Damage Limitations. Except for indemnity obligations arising under Section 4.4, confidentiality obligations arising under Section 5.1, or payment obligations arising under this Agreement: (i) each Party's total liability for any and all causes and claims whether based in contract, warranty, tort or otherwise shall be limited to the actual direct damages sustained by the damaged Party under this Agreement, but in no event greater than an amount equivalent to the total MRC payable by Customer over the preceding twelve months for the Access or Service affected or if the claim arises prior to the Activation Date, an amount equivalent to the total MRC payable by Customer for the first twelve months of the Order Term, and (ii) NEITHER PARTY SHALL BE LIABLE TO THE OTHER PARTY FOR ANY DAMAGES FOR LOST PROFITS, LOST REVENUES, LOSS OF GOODWILL, LOSS OF DATA, ANTICIPATED SAVINGS OR COST OF PURCHASING REPLACEMENT SERVICES, OR ANY INDIRECT, INCIDENTAL, SPECIAL, CONSEQUENTIAL, EXEMPLARY OR PUNITIVE DAMAGES ARISING OUT OF THE PERFORMANCE OR FAILURE TO PERFORM UNDER THE AGREEMENT. Notwithstanding anything to the contrary, Customer's sole and exclusive remedy for any non-performance, defect or failure to deliver the Access or Service are the performance credits and/or other remedies expressly stated in the relevant Customer Schedule.

4.2 No Warranty. ZAYO MAKES NO WARRANTIES OR REPRESENTATIONS, EXPRESS OR IMPLIED, EITHER IN FACT OR BY OPERATION OF LAW, STATUTORY OR OTHERWISE, INCLUDING WARRANTIES OF MERCHANTABILITY OR FITNESS FOR ANY PARTICULAR PURPOSE.

4.3 No Liability for Certain Actions. Zayo exercises no control over and is not responsible for the content of any information transmitted or received through the use of the Access or the Services. Other than as expressly stated in the Agreement, Customer shall be solely responsible for all of the security and confidentiality of information it transmits using the Access or Service.

4.4 Indemnification. Each Party (an “**Indemnifying Party**”) shall indemnify, defend and hold harmless the other Party, its directors, officers, employees, agents, contractors, successors and assigns (“**Indemnified Party**”) harmless from and against all losses, damages, costs, expenses and liabilities (including reasonable attorney's fees and expenses) incurred by such Indemnified Party arising from any third party claims relating to: (i) any physical damage to tangible property, or personal injury or death caused by the gross negligence or willful misconduct of the Indemnifying Party, or (ii) infringement or misappropriation of such third party's intellectual property right caused by the Indemnifying Party, provided, however, that Zayo is not obligated to indemnify Customer, and Customer shall defend and indemnify Zayo as an Indemnified Party, for any claims or actions commenced by any third party, including end users, arising from or in connection with goods or services provided by Customer that incorporate any of the Access or Services.

ARTICLE 5 – MISCELLANEOUS PROVISIONS

5.1 Confidentiality. Information or documentation exchanged between the Parties in performing this Agreement, including the terms of this Agreement, are subject to the terms of any non-disclosure agreement in effect between the Parties, and if none, neither Party will disclose Confidential Information to third parties (other than to vendors, if and as needed to perform under this Agreement) without the express consent of the other Party. Each Party will limit disclosure and access to Confidential Information to those of its employees, vendors, or other representatives who reasonably require such access to perform under this Agreement and who are subject to confidentiality obligations at least as restrictive as those required herein. “Confidential Information” means any information disclosed by one Party to the other in connection with the Agreement, including any terms of this Agreement and does not include information that: (i) is independently developed by the receiving Party, (ii) is lawfully received by the receiving Party free of any obligation to keep it confidential, or (iii) becomes generally available to the public other than by breach of this Agreement.

5.2 Force Majeure. Neither Party shall be liable, nor shall any credit allowance or other remedy be extended, for any failure or hindrance of performance hereunder due to causes beyond its reasonable control (a “**Force Majeure Event**”). The Party claiming relief under this Section shall notify the other Party of the occurrence or existence of the event and of the termination of such event.

5.3 Subject to Laws. Each Party is responsible for complying with laws and regulations applicable to it, including but not limited to applicable: (a) federal, state and local laws; (b) regulations, rulings and orders of government agencies; (c) data protection legislation; (d) laws, statutes, regulations and codes relating to anti-bribery and anti-corruption; and (e) import, export and economic sanction laws and regulations. Neither Party shall use the Access or Services for any unlawful purposes.

5.4 Governing Law; Venue; Prevailing Party. The Agreement shall be governed by and construed in accordance with the laws of Delaware, without giving effect to any conflict of law principles. Venue arising under the Agreement shall be Delaware. The United Nations Convention on Contracts for the International Sale of Goods does not apply. If suit is brought or an attorney is retained by either party to enforce the terms of the Agreement or to collect any money as due hereunder or to collect any money damages for breach hereof, the prevailing party shall be entitled to recover its reasonable attorneys’ fees and related expenses incurred in connection therewith.

5.5 Notices. Notices under this MCA shall be in writing and delivered by electronic mail or certified mail, return receipt requested, or by a nationally recognized courier to the persons whose names and business addresses appear below, and such notice shall be effective on the date of receipt, or refusal of delivery, by the receiving Party. **In lieu of the foregoing notice requirement, if Customer is disconnecting Access or discontinuing Service(s) of any type for any reason, Customer must submit the disconnection request through the form located at <https://www.zayo.com/disconnectservice/>**

If to Zayo:

Zayo Group, LLC
Attn: General Counsel, Legal
1821 30th Street, Unit A
Boulder, CO 80301
Email: legal@zayo.com

Billing Disputes:

Zayo Group, LLC:
Attn: Accounts Receivable
1821 30th Street, Unit A
Boulder, CO 80301
Email: customerservice@zayo.com

If to Customer:

**[INSERT CUSTOMER NAME] Medina Valley
Independent School District
Attn: (insert Name) Scott Laleman
(Address) 8449 FM 471 S
City-State-Zip Castroville, TX 78009**

Email: **(insert email) scott.laleman@mvisd.org**

(if this “Customer” section is left blank, notice shall be deemed effective if delivered to Customer’s registered office address or the last Customer address provided to Zayo by Customer)

5.6 Assignment. Neither Party shall transfer or assign, voluntarily or by operation of law or otherwise, its obligations under the Agreement without the prior written consent of the other party, except no such consent shall be required in the event of a merger, reorganization, consolidation or sale of substantially all of the Party’s assets or business in which case the assigning party shall provide notice to the non-assigning Party; provided, however, that Customer may only transfer or assign under this provision if its account balance with Zayo is current. Zayo may assign in whole or in part the Agreement or any of its rights and obligations hereunder to any Zayo Affiliate without prior notice to Customer. The Agreement shall be binding upon and inure to the benefit of the Parties and their respective successors and assigns.

5.7 No Third Party Beneficiaries; Relationship and Counterparts. The Agreement is not intended for, nor shall it be for the benefit of or enforceable by, any third party or person not a Party hereto, including without limitation, end users. The Agreement does not

create a partnership, joint venture or agency relationship between the Parties. Neither Party shall have any authority to bind the other Party to any agreement, understanding or other instrument, in any manner whatsoever. The Agreement may be executed in one or more counterparts, all of which taken together shall constitute one instrument. The Agreement may be executed via a recognized electronic signature service and/or signed, scanned and emailed to Zayo, and any such signatures shall be treated as original signatures.

5.8 Entire Agreement; Amendment. The Agreement constitutes the entire and final agreement and understanding between the Parties, expressed or implied, with respect to the Access and Services ordered after the Effective Date and supersedes all other prior or contemporaneous representations, understandings or agreements. No alteration or variation of the terms of any provision shall be valid unless made in writing and signed by the Parties. If any provision of the Agreement shall be held to be invalid or unenforceable, the remaining provisions of the Agreement shall be unimpaired and shall remain in effect and be binding upon the Parties. No course of dealing and no failure to exercise any right hereunder shall be construed as a waiver of any provision hereof.

ZAYO GROUP, LLC

[\[CUSTOMER NAME Medina Valley Independent School District\]](#)

Signature:

Signature:

Name:

Name:

[Beth Zinsmeyer](#)

Title:

Title:

[MVISD Board President](#)

CUSTOMER SCHEDULE
Ethernet, IP, & WANs

This Ethernet, IP, and WANs Customer Schedule (“**Customer Schedule**”) dated **MONTH-FEBRUARY DAY26**, 20 **YR24**, is subject to, and made a part of, that Master Customer Agreement or Master Service Agreement (“**MCA**” or “**Master Customer Agreement**”) dated **MONTH-FEBRUARY DAY26**, 20 **YR-24** entered into between the undersigned Parties. Zayo owns and operates fiber networks and other related telecommunications facilities and is in the business of providing certain Ethernet, IP, and WANs connectivity offerings (each, an “**Offering**”, collectively, “**Offerings**”). Capitalized terms not defined herein will have the meaning ascribed to such terms in the MCA.

1. DEFINITIONS. The following additional definitions shall apply to Offerings:

- 1.1 95th Percentile Calculation** means the calculation method used to measure Bandwidth usage for Customer Orders which specify Burst Bandwidth. Samples of average Bandwidth utilization rates of both inbound and outbound traffic from Customer port(s) are collected in five (5) minute intervals over a calendar month. The higher of such samples (Inbound or Outbound) are placed on a list and sorted from highest to lowest in amount of Mbps. The highest five percent (5%) of samples are discarded and the next highest sample is chosen to represent the 95th percentile calculation for that month.
- 1.2 Allocated MRC** means, for a multipoint Offering, a portion of MRC allocated by Offering and/or each Customer location as specified on a Customer Order, and if not so specified in a Customer Order then prorated based on the number of locations associated with the Offering.
- 1.3 Bandwidth** means the amount of data (quantified as Mbps (“**M**”) or Gbps (“**G**”)) made available to Customer as specified in a Customer Order, or in the event of usage based billing, the amount of data actually transmitted by Customer’s Equipment.
- 1.4 Bandwidth Commitment** means the Customer’s commitment to pay for a certain level of Bandwidth on a monthly basis. Customer agrees to pay the MRC specified on the Customer Order as a minimum monthly charge regardless of actual usage. Any applicable Bandwidth Commitment will be specified on a Customer Order.
- 1.5 Burst Bandwidth** means the amount of Bandwidth usage, based on the 95th Percentile Calculation, in excess of a Bandwidth Commitment. Any usage in excess of the Bandwidth Commitment will result in a usage charge at the burst rate identified in the Customer Order, based on the 95th Percentile Calculation. Usage charges are billed in arrears representing excess usage for the prior month. Burst Bandwidth must be specified on a Customer Order to be applicable.
- 1.6 Demarcation Point** means the interface port where Zayo hands off service to Customer unless otherwise specified on a Customer Order.
- 1.7 Diverse Offering** means an Offering designed to reduce points of failure by maintaining separation of paths, routes or equipment. Zayo offers a variety of diverse solutions. The Customer Order for such Offering shall specifically state that such Offering is a Diverse Offering and will include the type of diversity applicable to such Offering.
- 1.8 NNI** means “**Network-to-Network Interface**” and is an interface used to interconnect a customer’s network to Zayo’s network.
- 1.9 Off-Net** means any Offering which does not meet the definition of On-Net in Section 1.10.
- 1.10 On-Net** means any Offering which connects two locations to which Zayo is already providing the same type of Offering at the time of the Customer Order and which is provisioned entirely on Zayo facilities and does not include any Third Party Offerings (as defined herein) or special construction.
- 1.11 Protected Offering** means an Offering which includes a protection scheme that allows traffic to be rerouted in the event of a fiber cut or equipment failure. For an Offering to be deemed a Protected Offering hereunder, the Customer Order for such Offering shall specifically state that such Offering is a Protected Offering.
- 1.12 Offering Element** means each Offering element set forth in Section 6 for which a Performance Level Target is prescribed (e.g., Availability and Latency).

1.13 Third Party Cloud Provider (TPCP) means a non-Zayo entity offering a cloud-based platform, infrastructure or application to which Customer desires to interconnect an Offering, and with which Customer has a direct commercial relationship.

1.14 UNI means “**User Network Interface**” and is an interface used to interconnect a customer’s network to Zayo’s network.

1.15 Unprotected Offering means an Offering which does not include a protection scheme that allows traffic to be rerouted in the event of a fiber cut or equipment failure. Any Offering not expressly designated as a Protected Offering on the applicable Customer Order shall be deemed an Unprotected Offering.

2. ACCEPTABLE USE POLICY. All Offerings are subject to and conditioned upon Zayo’s Acceptable Use Policy published at www.zayo.com, which is hereby incorporated into this Customer Schedule.

3. OFFERING DESCRIPTIONS

3.1 IP Transit/DIA Offerings

3.1.1 IP Transit (“IP Transit”) provides multiservice 1G, 10G and/or 100G ports (minimum 1G commit for a 10G port) available only in designated Zayo IP Points of Presence (“**POP**”). Customer provides cross-connect within POP.

3.1.2 Dedicated Internet Access (“DIA”) is connectivity and access to the Internet via Zayo’s peering arrangements with various Internet service providers. DIA is provided from a Zayo POP to a customer location.

3.1.3 Additional Features: Customer may request related services, including additional IP addresses, aggregated billing, Burst Bandwidth, primary and secondary domain name service (“**DNS**”), or border gateway protocol (“**BGP**”) services.

3.1.4 DDoS Protection Offering. Distributed denial of service (“**DDoS**”) attacks may from time to time affect the Offering that Zayo provides to Customer by flooding Customer’s system with incoming traffic. Zayo’s DDoS protection Offering (“**DDoS Protection**”) is an optional service which attempts to mitigate DDoS attacks in accordance with the following procedure:

3.1.4.1 Prior to the Activation Date, Customer and Zayo shall agree on a list of IP addresses to which the DDoS Protection applies;

3.1.4.2 Upon service activation, Zayo will perform an analysis of Customer’s normal Internet traffic and use this traffic profile to identify potential anomalies that could indicate a DDoS attack; and

3.1.4.3 Upon detection of anomaly that is indicative of a DDoS attack, Zayo will notify pre-determined Customer contacts that traffic patterns indicate a DDoS attack.

3.1.4.4 DDoS Protection includes managed re-routing of Customer’s DDoS-impacted traffic to one of Zayo’s global scrubbing facilities which attempts to identify and remove the offending traffic; and

3.1.4.5 DDoS Protection does not include: load balancing of traffic or of the Offerings; permanent archival/storage of log files; forensics or investigations; legal case preparation or PR incident support; security consulting services; disaster recovery planning; or permanent filtering/cleaning of traffic.

3.1.4.6 DDoS Unpredictability - Customer acknowledges and agrees that: (i) due to the unpredictable nature of DDoS attacks, there is no guarantee or warranty hereunder concerning the ability of the DDoS Protection to mitigate or defeat any DDoS attack; and (ii) Zayo shall have no liability whatsoever for damages related to lost data, lost profits or lost revenues, even if Zayo has been advised of the possibility of such damages, or damages which result from any failure or inability of the DDoS Protection to mitigate or defeat any one or more DDoS attacks.

3.1.4.7 Special Terms for Sustained DDoS Attack - Zayo may suspend or blackhole Customer’s traffic without notice if Customer suffers a sustained DDoS attack whereby Customer’s traffic materially impacts Zayo’s network.

3.1.5 Shared Broadband Internet Offering is provided across a Zayo partner network using shared access technology and bandwidth is not assured due to the access network being subject to oversubscription. Bandwidth speeds are “up to” the quoted amount and typically upload and download speeds are asymmetric. The Performance Level Targets shall not apply to Shared Broadband Internet Offering.

3.2 Ethernet LAN (“ELAN”) is a layer 2 service comprised of a connection to a Zayo POP providing multipoint-to-multipoint Ethernet transport between Customer locations. ELAN Offering can support unicast traffic and a limited amount of multicast or broadcast traffic. ELAN can be provided with QoS which allows Customer to differentiate traffic within the ELAN and on the Zayo network.

3.3 Ethernet (“Ethernet”) is a layer 2 service that provides dedicated or shared point-to-point or point-to-multipoint connectivity for transport of voice, data, video or other forms of communications traffic. Ethernet Offerings meet IEEE 802.3 standards and uses 802.1Q VLAN tagging and stacking to support certain configurations. Ethernet Offerings generally follow the Metro Ethernet Forum definitions of Ethernet Private Line (“**EPL**”) and Ethernet Virtual Private Line (which may also be referred to as VPLS on a Customer Order) (“**EVPL**”) network configurations and can be purchased with the following configurations:

3.3.4 EPL: Metro or intercity Offering comprised of a UNI at each Customer site connected via an Ethernet virtual circuit (“**EVC**”) providing point-to-point Ethernet transport.

3.3.5 EVPL – UNI: A UNI handoff which connects to an NNI via an EVC.

3.3.6 EVPL – NNI: A NNI handoff which aggregates multiple EVC Offerings.

3.4 IP for Virtual Private Networks (“IP-VPN”) is a layer 3 service leveraging Zayo’s IP network. IP-VPN provides a virtual private network (“**VPN**”) that supports the interconnection of multiple Customer locations through Zayo’s multiprotocol label switching (“**MPLS**”) network backbone. IP-VPN is delivered to the Customer premises over On-Net or Off-Net facilities, and distributed as a Layer 3 Internet Protocol (“**IP**”) service from the Customer Premises Equipment (“**CPE**”) router. IP-VPN can be provided with QoS which allows Customer to differentiate traffic within the IP-VPN Offering and on the Zayo network.

3.4.4 Management Type: IP-VPN Offering may be available with the following managed service options on a per-location basis.

3.4.4.1 Unmanaged: Access to utilization reporting in the Tranzact portal.

3.4.4.2 Basic Management: Access to utilization and performance reporting in the Tranzact portal and Offering may be offered with Proactive Notification (see Section 3.7) as an optional service.

3.4.4.3 Advanced Management: Includes Basic Management features plus router configuration, change management, and hardware support.

3.4.5 IP-VPN Managed Router: Customer may request Zayo provide a CPE router to enable the following Zayo-managed configurations. Advanced Management is required for this option.

3.4.5.1 Customer edge routing protocol enablement

3.4.5.2 Dynamic Host Configuration Protocol (DHCP) server or DHCP relay

3.4.5.3 Access Control Lists (ACL)

3.4.5.4 Static routes

3.4.5.5 Secondary IP address

3.4.5.6 Read Only Simple Network Management Protocol (ROSNMP) access

3.4.5.7 Netflow to Customer collector

3.5 Software-Defined Wide Area Network (“SD-WAN”) is a virtual overlay network which provides a fully-meshed, private VPN service. SD-WAN is a managed service using controllers, network gateways, and Zayo-provided Meraki hardware and software at the Customer premises. SD-WAN Offering provided pursuant to this Customer Schedule is limited to the provision of Meraki hardware and software; other SD-WAN offerings may be available to Customer under Zayo’s Edge Solutions Customer Schedule. Notwithstanding the foregoing, this Offering may be configurable with and application level traffic steering and includes an online portal. Network access methods for SD-WAN may include “bring-your-own-Internet-access” wired or wireless Internet connectivity. After SD-WAN activation, Customer may submit change requests to Zayo or request access to self-manage configurations via the portal. Zayo will provide up to five (5) configuration changes per network, per month, subject to availability, at no additional charge, however, Zayo may charge Customer for excessive changes or corrections.

3.6 Cloudlink is a Layer 2 or Layer 3 Offering providing direct private connectivity to a TPCSP network interconnect point of presence. While on the Zayo network, traffic destined for the TPCSP, or received from the CSP does not traverse the public Internet and travels across a private customer circuit. CloudLink can be used on a variety of transporting methods including WAN, Ethernet and Wavelengths. CloudLink performance level metrics are based on the transportation method. The performance level metrics for Cloudlink using Wavelengths are addressed in that specific Customer Schedule for Wavelengths Offerings.

3.6.1 WWAN CloudLink is an Offering that enables Customer to extend their IP-VPN, SD-WAN, or ELAN to a TPCP in order to share TPCP services to one (1) or more Customer locations on the IP-VPN, SD-WAN, or ELAN.

3.6.2 BGP Management: Customer must establish a direct relationship with each TPCP and is solely responsible for all charges or costs from the TPCP. Customer is responsible for: (1) all BGP sessions connecting to and within the TPCP network; and (2) all public and private addresses required by the TPCP.

3.6.3 Managed IP-VPN Option: IP-VPN connectivity for CloudLink may include Zayo-provided managed routers at the Customer premises. This option may include Network Address Translation (NAT) for the integration of public TPCP offerings.

3.6.4 Hosted CloudLink is an Offering where Customer shares a multi-tenant Cloud Service Provider (CSP) port. Traffic is separated via individual VLAN IDs. Due to its shared nature, this Offering is not intended to support any one customer’s high sustained traffic, and Zayo reserves the right to throttle Customer’s traffic if Customer’s high-sustained traffic impacts other customers’ use of the shared CSP port.

4. COMPONENTS AND INSTALLATION.

4.1 Zayo Components. Zayo, or its agent, may provide, install, maintain, repair, operate and control Zayo’s components and equipment (“**Zayo Components**”). The Zayo Components shall remain the sole and exclusive property of Zayo, and nothing contained herein shall give or convey to Customer, or any other person, any ownership right, title or interest whatsoever in the Zayo Components (other than the access rights included within an Offering), notwithstanding that such Zayo Components may be, or become, attached to, or embedded in, realty. Customer shall not tamper with, remove or conceal any identifying plates, tags or labels identifying Zayo’s ownership interest in the Zayo Components. Customer shall not adjust, align, attempt to repair, relocate or remove the Zayo Components, except as expressly authorized in writing by Zayo. Customer shall be liable for any loss of or damage to the Zayo Components caused by Customer’s negligence, intentional acts, or unauthorized maintenance and shall reimburse Zayo for the same within thirty (30) days after receipt by Customer of a request for reimbursement. Customer, at its sole cost and expense, shall be required to obtain space and power to support the Zayo Components for the Offering for the duration of the Order Term.

4.2 Access and Customer Premises Obligations. Customer, at its sole cost and expense, shall provide Zayo with all necessary information and access to all applicable Customer locations for purposes of providing the Offerings, including installation, maintenance, and repair of Zayo Components on Customer premises. For purposes of the preceding sentence, “access” shall include without limitation any necessary license(s) to access, occupy and conduct telecommunication operations within each respective building and or property for the duration of the Order Term (including any necessary rights for Zayo to enter and access each building, and for providing all necessary cable pathways, building access and/or occupancy fees, riser fees, cross-connects and cross-connect fees, coordination at any third party owned location, and, where applicable, necessary space for Zayo’s fiber termination panel). However, notwithstanding Customer’s foregoing responsibility, if Zayo is required by a third party to obtain and maintain any such license to access the building or property, Customer agrees to reimburse Zayo for its costs related to obtaining and maintaining such licenses during the Order Term. Zayo shall provide reasonable notice under the circumstances to Customer prior to entering Customer’s point of presence to install, maintain or repair any of the Zayo Components.

Customer will provide a safe place to work and comply with all applicable laws regarding the working conditions on the Customer premises.

4.3 Customer Equipment. Customer is responsible, at its sole cost and expense, for connecting to the Demarcation Point specified in the Customer Order. Components, equipment and operations beyond the Demarcation Point and/or interconnection between Zayo's facilities and terminal components and the wiring at the Demarcation Point shall be the responsibility of Customer ("**Customer Equipment**"). Customer must procure and maintain, at its sole cost and expense, Customer Equipment which is technically compatible with the Offering and the Zayo network. Zayo shall have no obligation to install, maintain or repair any non-Zayo components or equipment, including any Customer Equipment. If, on responding to a Customer-initiated service call, Zayo reasonably determines that the cause of the deficiency was a failure, malfunction or the inadequacy of components or equipment other than the Zayo Components, Customer shall compensate Zayo for actual time and materials expended during the service call.

5. SERVICE REQUESTS AND DELIVERY.

5.1 Acceptance and Projected Activation Date. Within five (5) business days of Zayo's acknowledgment to Customer of receipt of a Customer Order for On-Net Offerings, or within five (5) business days after Zayo's receipt of its Off-Net provider's projected service activation date for Off-Net Offerings, Zayo will notify Customer (in writing or electronically) of its acceptance of such Customer Order ("**Customer Order Acceptance**"), at which time such Customer Order becomes a binding obligation to purchase the Offerings therein, or rejection of such Customer Order, in which case Zayo will communicate to Customer why it is unable to accept such Customer Order. Zayo may accept or reject any submitted Customer Order in its sole discretion.

5.2 Firm Order Commitment Date. Unless the date by which Zayo estimates it will turn over the Offering for Customer's use ("**FOC Date**") is already stated in a Customer Order, Zayo will provide the FOC Date following submission of the Customer Order. For Off-Net Offerings, Zayo shall notify Customer of the FOC Date within two (2) business days after Zayo receives an installation date from its Third Party Provider.

5.3 Offering Activation. After Zayo's required tasks have been completed and Zayo has determined that the Offering conforms to the relevant Customer Order, Zayo will notify Customer that the Offering has been activated in accordance with the Customer Order and is available for use by Customer ("**Offering Activation Notice**"). The "**Activation Date**" shall be the earlier of (i) the date on which Customer begins using the Offering for any purpose other than testing; or (ii) the date that Zayo has sent the Offering Activation Notice to Customer. Customer shall have five (5) days following the Activation Date in which to notify Zayo that it is rejecting the Offering because the Offering does not conform to the Customer Order. If Customer has notified Zayo within such five (5) day period that the Offering does not conform to the Customer Order, then Zayo shall take such steps reasonably necessary to conform the Offering to the Customer Order, at which time Zayo shall issue a new Offering Activation Notice and the Customer acceptance process above shall be repeated. If the Activation Date is delayed as a result of Customer's failure to meet its responsibilities under the MCA or this Customer Schedule, the Activation Date will be deemed to be the later of (a) the FOC Date or (b) the date that Zayo has completed its tasks to deliver the Offering to the best of its ability.

5.4 Incrementally Delivered Offerings. Unless otherwise specified in a Customer Order, for individually delivered Offerings, Zayo may incrementally deliver when ready, which may result in different Activation Dates for such incrementally delivered Offerings. For multipoint Offerings, Zayo may incrementally deliver an Offering to each Customer location when ready, and the Order Term for such incrementally delivered multipoint Offerings shall begin on the Activation Date of the first location and/or circuit delivered and shall end after the period specified as the Order Term from the Activation Date of the last location and/or circuit delivered. Unless otherwise set forth in a Customer Order, the charges associated with a delivered Offering will be based upon the Allocated MRC. Any Bandwidth Commitment for an incrementally delivered service will be proportionally reduced to reflect the number of locations incrementally delivered out of the total number of locations included under such Bandwidth Commitment and Burst Bandwidth will be determined by using the level then in effect as of the last day of each calendar month. For all multipoint Offerings, Outage Credits shall be granted only to affected Customer locations based on Allocated MRC.

6. PERFORMANCE LEVEL TARGETS

6.1 Availability: For IP-VPN, ELAN, CloudLink, SD-WAN, and Ethernet, "**Availability**" means the percentage of time that a Customer location is connected to and can be reached by one or more other Customer locations on the same Customer network. For DIA and IP Transit, Availability means the percentage of time a Customer location can access the Internet. If the Offering is unavailable, measurement of the unavailable period begins when a Zayo trouble ticket is opened and is calculated on a calendar month basis. The Offering Credit to which Customer may be entitled is ten percent (10%) of Allocated MRC for each two hour period that the Offering is unavailable following the Performance Level Target set forth below. Outage Credits are available

for On-Net Offerings as described above. Outage Credits for Off-Net Offerings are passed through based on credits received from the underlying Off-Net provider.

Availability		
Offering	Configuration	Performance Level Target
IP-VPN	Unprotected	99.9%
	Protected	99.95%
	Diverse	99.99%
ELAN	Unprotected	99.9%
	Protected	99.95%
	Diverse	99.99%
DIA	Unprotected	99.9%
	Protected	99.95%
IP Transit	Unprotected	99.9%
	Protected	99.95%
CloudLink	Unprotected	99.9%
	Protected	100%
SD-WAN Meraki	Customer-Provided Internet Access	Not Guaranteed
	Zayo-Provided 1 Wired Internet Connection	99.99%
	Zayo-Provided 1 Wired and 1 Wireless LTE/4G Internet Connections	100%
Ethernet	Unprotected	99.9%
	Protected	99.95%
	Diverse	99.99%

6.2 Latency (Inter-frame Delay): “Latency” means time it takes for a packet of data to get from one Customer premises to a separate Customer premises and back. The Performance Level Target for Latency is applicable to packets that traverse a single network and conform to the performance attributes of the Offering. Latency Performance Level Targets are available for On-Net IP-VPN, ELAN, SD-WAN, and Ethernet Offerings and Outage Credits are calculated as ten percent (10%) of Allocated MRC for each hour beyond two (2) hours that the Offering fails to meet the Performance Level Target.

Geography	Performance Level Target
On-Net National or regional (distances up to 2500 miles)	< 65 ms
On-Net National or regional (distances over 2500 miles)	< 85 ms
On-Net Global	< 300 ms

6.3 Packet Delivery: “Packet Delivery” means the percentage of IP packets that are successfully transmitted across the Customer’s network without loss, measured in each direction between Zayo PEs serving the applicable Customer location. The Performance Level Target for Packet Delivery is applicable to packets that traverse a single network and conform to the performance attributes of the Offering. Packet Delivery Performance Level Targets are applicable to On-Net IP-VPN, ELAN, SD-WAN, and Ethernet Offerings and Outage Credits are calculated as ten percent (10%) of Allocated MRC for each hour beyond two (2) hours that the Offering fails to meet the Performance Level Target.

Geography	Performance Level Target
Distance up to 2500 miles	99.995%
Distance over 2500 miles	99.95%
Global	99.9%

6.4 Jitter (Inter-frame Deviation): “Jitter” means the one-way variance in the arrival time of packets at a Zayo PE serving the applicable Customer location, given that the packets are of equal size and presented at a constant rate, without error, and within contracted delivery rates. Zayo calculates Jitter as an average of each direction’s jitter between two Customer locations. Jitter Performance Level Targets are applicable to On-Net IP-VPN, ELAN, and SD-WAN Offerings and Outage Credits are calculated as ten percent (10%) of Allocated MRC for each hour beyond two (2) hours that the Offering fails to meet the Performance Level Target.

CE to CE Distance	Performance Level Target
Regional (intracontinental)	< 3 ms
Global (intercontinental)	< 10 ms

6.5 Quality of Offering: “QoS” means the option for prioritized traffic from applications that may compete for the same network resources by assigning pre-determined levels of network priority to bandwidth. QoS Performance Level Targets are applicable to On-Net Ethernet Offerings and Outage Credits are calculated as ten percent (10%) of Allocated MRC for each hour beyond two (2) hours that the Offering fails to meet the Performance Level Target. The following levels of QoS may be available (“QoS Classes”):

QoS Classes	Performance Level Target
Critical	99.8%
Preferred	99.7%

6.6 DDoS: If purchased, Zayo will initiate DDoS Protection (“Protection Initiation”) within fifteen (15) minutes after Zayo receives authorization from the Customer to begin protection and a trouble ticket is opened (“Authorization”). If Protection Initiation does not occur within fifteen (15) minutes of Authorization, then the Offering Credit is ten percent (10%) of Allocated MRC for each subsequent fifteen (15) minute period that Protection Initiation has not yet occurred.

7. OUTAGE CREDITS.

7.1 Outage. Zayo will issue Outage Credits to Customer for circuits affected by interruptions in Offering for Offering Element failures set forth in Section 6 (“Outage”); provided, however, that any such interruption or failure of an Offering Element will not be deemed an Outage if caused by: (a) any act or omission of the Customer or its End User Customers, or their representatives, contractors, agents, authorized invitees, successors or assigns; (b) the configuration, failure or malfunction of non-Zayo equipment or systems; (c) scheduled maintenance or planned enhancements or upgrades to Zayo's network; (d) Zayo not being given reasonable access to the premises; (e) Customer exceeding the maximum capacity of a port connection or any other rate limitation as set forth in the applicable Customer Order; or (f) a Force Majeure Event. Each of the events described in Section 8 shall be deemed an “Excused Outage.”

7.2 Outage Credit. Customer may be entitled to one of the service credits set forth in Section 6 (“Outage Credit”). For any multipoint Offering, the Allocated MRC shall be used for purposes of calculating Outage Credit per the table in Section 6. The duration of an Outage begins when Zayo records a trouble ticket number and ends when the Offering is restored or not failing to meet the Performance Level Targets in Section 6 (“Outage Duration”). Outage Duration is applicable to specific affected circuits and shall not be aggregated among circuits. Unless otherwise specified, the Performance Level Objectives applicable to CloudLink Offerings shall be the Performance Level Objectives applicable to the underlying Offering used to deliver such CloudLink Offering. In the event of an Outage during which Customer experiences multiple Offering Element failures and/or Outages, the Outage Credits for each affected Offering Element shall not be aggregated; rather, the Outage Credit shall be the greater of the Outage Credit applicable to any individual Offering Element in Section 6. The maximum Outage Credit in a calendar month for any affected circuit shall not exceed 50% of the Allocated MRC for the affected circuit.

7.3 Chronic Outage: Customer may terminate the affected On-Net Offering without incurring early termination charges if: (i) for an On-Net Protected Offering, Customer experiences three (3) or more related Outages on such Offering, each with an Outage Duration lasting more than one (1) hour in any thirty (30) day period; or (ii) for an On-Net Unprotected Offering, Customer experiences three (3) or more related Outages on such Offering, each with an Outage Duration lasting more than eight (8) hours in any thirty (30) day period. In the event of an Outage during which Customer experiences multiple Offering Element failures and/or Outages, the Outage Duration for each affected Offering Element shall not be aggregated; rather, the Outage Duration used to calculate the applicable Outage Credit under Section 7.2 above shall apply for purposes of determining whether Customer is entitled to terminate the affected Offering under this Section. In order to exercise a right to terminate under this Section, Customer must notify Zayo of its intent to terminate the affected Offering in writing within thirty (30) days after the event giving rise to a right of termination. Customer shall be deemed to have waived its right to terminate under this Section if it fails to provide the requisite notice within such thirty (30) day period. Zayo reserves the right to refuse the foregoing termination right if Customer has any past-due balances. Notwithstanding the foregoing, Customer may not terminate the affected Offering under this section if Zayo is able to cure (to Customer's reasonable satisfaction) the issue(s) giving rise to such Outages under this provision within thirty (30) calendar days of the chronic outage triggering event.

8. ISSUANCE OF CREDITS. In order to receive Outage Credit, Customer must (a) immediately report the Outage to the NCC and open a trouble ticket and (b) make a written request for an Outage Credit within thirty (30) calendar days following the end of the month in which the Outage occurred. Upon receipt of Customer's request, Zayo will investigate the claim under the terms described in this Customer Schedule. Credits will be granted only if Customer has paid all outstanding invoices by the Due Dates thereof. The issuance of credits pursuant to this Section and Customer's right to terminate in

accordance with Section 7.3 above are Customer's sole remedies for any failure or non-performance of Offerings set forth in this Customer Schedule. Outage Credits shall be deducted from the charges payable by Customer hereunder and shall be expressly indicated on the Customer invoice.

- 9. **THIRD PARTY SERVICES.** The Offerings may incorporate services provided by a third party (“**Third Party Provider**”), including, but not limited to, interconnect services (collectively “**Third Party Offerings**”). The costs of Third Party Offerings will be reflected in the applicable Customer Order provided that, following written notice to Customer, Zayo may adjust the rates for Offerings that incorporate Third Party Offerings to reflect, without mark up, any increases in costs imposed on Zayo for Third Party Offerings after the effective date of the applicable Customer Order. The service-specific terms and performance metrics associated with Third Party Offerings, including any available credits for non-performance or service degradation, are limited to Zayo’s terms with, and credits collected from, the applicable Third Party Provider. If Customer cancels an Offering that incorporates Third Party Offerings without cause prior to the expiration of the applicable Order Term, Customer shall reimburse Zayo for any costs incurred by Zayo to terminate such Third Party Offerings. Where a Customer has requested a disconnect for an Offering for which an LOA/CFA was required, the Customer must produce documentation of disconnect confirmation (disconnect FOC or other) from the Third Party Provider.

- 10. **MAINTENANCE. “Routine Maintenance”** is routine and preventative maintenance and repairs that Zayo deems necessary to ensure proper functioning of the Zayo network. The Zayo NOC will generally conduct such planned Schedule Maintenance outside normal working hours anytime between 12:00 AM to 5:00 AM (local time) seven (7) days a week. Zayo will provide Customer with fourteen (14) days prior notice of such Routine Maintenance that Zayo reasonably believes may impact availability. All maintenance other than Routine Maintenance as described above shall be deemed to be Non-Routine Maintenance. For any Non-Routine Maintenance performed to restore functionality of the Offerings, Customer will first use commercially reasonable efforts to determine that any disruption in the functionality of the Offering is not on the Customer’s side of the Demarcation Point. After verifying that the problem is not on Customer’s side of the Demarcation Point, Customer shall open a Trouble Case for Technical Support by contacting Zayo Customer Support at 1-866-236-2824 (US and Canada) / +4420 3846 4222 (Europe) / 00800 4997 0737 (France), or ncc@zayo.com. Escalation procedures following opening of a Trouble Case can be found at <https://tranzact.zayo.com/#!/escalation-lists>.

- 11. **REGULATORY REQUIREMENT.** If the Federal Communications Commission (the “**FCC**”), the Canadian Radio-television and Telecommunications Commission (“**CRTC**”), any other regulatory body, or a court of competent jurisdiction issues a rule, regulation, law or order that has the effect of increasing the cost to provide the Offering or cancels, changes or supersedes any material term or provision of the Agreement (collectively “**Regulatory Requirement**”), then the Agreement shall be deemed modified in such a way as is necessary to comply with such Regulatory Requirement.

- 12. **AGGREGATED DISCONNECT.** For a multi-point Offering with aggregated bandwidth, as set forth in the applicable Customer Order, Customer may, upon ninety (90) days written notice to, and corresponding approval from, Zayo, terminate a portion of such Offering (the “Disconnected Circuit”), provided, however that if such termination is during the initial Order Term or a Renewal Term, Customer will remain liable for 100% of the remaining MRC through the applicable Order Term or Renewal Term for the Disconnected Circuit (“**Circuit Disconnection Right**”). If Customer exercises this Circuit Disconnection Right and complies with the terms provided herein, Customer’s MRC for the remaining Offering may thereafter be reduced by the corresponding MRC of the Disconnected Circuit. This Circuit Disconnection Right is subject to Zayo's review and approval.

ZAYO GROUP, LLC

MEDINA VALLEY INDEPENDENT SCHOOL DISTRICT **ENTER**
CUSTOMER NAME HERE (“CUSTOMER”)

Signature: _____

Signature: _____

Name: _____

Name: Beth Zinsmeyer

Title: _____

Title: MVISD Board President

Medina Valley Independent School District

Agenda Item Memorandum

To: MVISD Board of Trustees

Date: February 26, 2024

RE: Consideration and possible approval of a Budget Amendment

The 2023-2024 budget has been approved by the Board of Trustees according to Texas property Tax Code, section 26.09 (e). Amendments to that budget must also be Board approved. The administration recommends a reclassification of existing funds within the General Fund budget for the purchase of cafeteria tables, middle school athletic uniforms, instruments, and technology circuit upgrades.

Medina Valley Independent School District

BUDGET AMENDMENT REQUEST FORM

Board Meeting Presentation Date: February 26, 2024
Fund Name & Number: General Fund - 199
Dept. Requesting Budget Amendment: Technology, Child Nutrition, Fine Arts, Athletics

PURPOSE OF AMENDMENT:

Reclassification of Existing Funds

Function Increase	35	\$ 39,149
	36	\$ 306,173
	53	\$ 100,000
Function Decrease	33	\$ 118,000
	34	\$ 327,322

EXPLANATION FOR AMENDMENT:

Function 35: General education portion of the MVMS cafeteria table purchase
Function 36: Middle school athletic uniforms and fine arts instruments (tubas/percussion)
Function 53: Replace of AT&T circuits

Function 33: Unallocated salaries in health services
Function 34: Bus purchases that will not arrive until next fiscal year

Medina Valley Independent School District

Agenda Item Memorandum

To: MVIDS Board of Trustees

Date: 02-26-2024

RE: Consider selection of engineering firm for the Medina Valley High School Portable Building Infrastructure Design Services and delegate authority to the Superintendent to proceed with contract approval.

- A school district may not construct a public work involving engineering in which the public health, welfare, or safety is involved unless the engineering plans, specifications, and estimates have been prepared by an engineer, and the engineering construction is performed under the direct supervision of an engineer. Tex. Occ. Code § 1001.407.
- Architects and engineers are providers of professional services and must be selected in accordance with the Professional Services Procurement Act (PSPA) rather than on the basis of competitive bidding or another method of competitive procurement. (Tex. Educ. Code 44.031(f)).
- A school district must first select the most highly qualified provider of those services on the basis of demonstrated competence and qualifications and then attempt to negotiate a contract at a fair and reasonable price. (Tex. Gov't Code 2254.004(a)).
- The district shall first attempt to negotiate a contract with the selected firm. If an agreement cannot be reached then the district may move on to a second firm to negotiate price. Once you have moved on to the second firm you may not reengage the first firm based on price negotiation.
- A request for qualifications solicitation is not required by statute.
- Administration is recommending Moy Tarin Ramirez Engineers, LLC.

January 31, 2024

Medina Valley Independent School District
Facilities Department
Attn: Mr. Rafael Barajas, Director of Construction
8752 FM 471 South
LaCoste, TX 78039



Re: **Professional Services Qualifications**

Mr. Barajas,

Moy Tarin Ramirez Engineers, LLC (MTR) is pleased to provide you with our Qualifications for Professional Services. As a full-service Civil Engineering and Survey firm, we have operated since 2002 in and around the San Antonio area, previously under the name of Moy Civil Engineers and transitioning to MTR in 2010. MTR opened for business as a fully staffed and equipped firm capable of providing all the necessary Land Surveying, Civil Engineering and Planning services required for any type of land development with a primary focus on Educational/Public School (K-12) work.

We base our operations out of our 11,300-sf office space located at 12770 Cimarron Path, Suite 100 in San Antonio, Texas. We have 16 Licensed Professional Engineers (PE's), 10 Engineers in Training (EIT's), 1 Registered Public Land Surveyor (RPLS), 2 Surveyors in Training (SIT's), 4 FAA Certified Small Unmanned Aerial Systems (sUAS) Pilots, 19 Technicians (CADD & Survey Crew), 12 Field Survey Personnel, and 8 Administrative Staff.

Our list of Engineering/Survey Services includes:

Civil Engineering Services:

- Land Use Planning
- Development Master Planning
- Water and Sewer System Design & Modeling
- Entitlement Research and Management
- Feasibility Analysis
- Site Layout and Design
- Roadway Design
- Design of Public and Private Drainage Systems
- Detention Pond Design
- Floodplain Studies and Floodplain Analysis
- Site Grading and Underfloor Grading
- Utility Layout and Coordination
- Stormwater Pollution Prevention Plans & Permitting
- Water Pollution Abatement Plans
- Platting and Permitting
- Construction Administration

Surveying Services:

- Land Records Research
- Boundary Surveys
- Topographic and Improvement Surveys
- As-Built Surveys
- Lot Surveys
- Tree Surveys
- ALTA/ACSM Surveys
- Construction Staking Services
- Legal Instrument Preparation
- Easement Preparation
- GPS Services
- Right-of-Way Mapping
- Geographic Information System (GIS) Mapping and Data Collection
- Light Detection and Ranging (LiDAR)
- Photogrammetry (aerial imagery)

Our extensive experience in the design of K-12 projects includes over 400 school projects ranging from portable buildings and playground renovations to new elementary, middle, and high school campuses for multiple public-school districts in and around the San Antonio area. Some of our work includes the following MVISD projects:

- Potranco Elementary School Addition
- Medina Valley High School Fine Arts Addition
- Castroville Elementary School Library & Classroom Addition
- Medina Valley High School Athletics Addition
- Medina Valley Middle School Addition
- La Coste Elementary School
- Castroville Elementary School Parking Addition #1 & 2
- MVISD Transportation Facility
- MVISD High School/Middle School Sewer Lift Station Analysis
- MVISD Agriscience and Tennis Courts
- MVISD Baseball Concession Building
- MVISD Higher Learning Facility
- MVISD Campus Mapping
- Loma Alta Middle School
- Luckey Ranch Elementary School
- Medina Valley Middle School Gym Addition
- MVISD High School Addition 2017 & 2019
- MVISD High Schools Detention Pond Reconstruction
- Ladera Elementary Schools
- Silos Elementary School
- Medina Valley High School #2
- Potranco Elementary School Drop off Lane Reconstruction
- Medina Valley Middle School Drop off Lane Improvements
- Medina Valley High School Football Field Reconstruction
- Various portable building additions and site feasibility studies

Additionally, MTR is a certified Small Business Enterprise (SBE), Minority Business Enterprise (MBE), Hispanic American Business Enterprise (HABE), and Historically Underutilized Business (HUB).

If you have any questions or require any further information, please feel free to contact me at nvandelist@mtrengineers.com or at 210-698-5051.

Thank you,



Nick Van Delist, PE, CFM, LEED AP
Senior Vice President
Moy Tarin Ramirez Engineers, LLC

February 12, 2024

Medina Valley Independent School District
Attn: Mr. Rafael Barajas, Director of Construction
8752 FM 471 South
LaCoste, TX 78039

Re: **Medina Valley Independent School District
Medina Valley High School Portable Buildings
Professional Services Proposal**

Mr. Barajas,

Moy Tarin Ramirez Engineers, LLC (MTR) is pleased to provide this proposal for professional services for the above projects. The following is our understanding of the scope of services required. Additional items may be included or removed from this scope of services at your request. The proposed services and associated fees are:

Professional Services:

1. Limited Civil Construction Documents:
 - Preparation of a Civil Site, and Utility Plans specifying proposed portable buildings layout (up to portable 11 buildings and associated improvements). Services include a site grading/keynote plan, site utility plan, site details, and a Storm Water Pollution Prevention Plan (less than 1 acre). Site design services assume no offsite grading and drainage plans are required, and minimal onsite grading, no field relocation, and existing ADA pathway is provided to the proposed portable location.
2. Fire Flow Test (subconsulted):
 - Conduct flow test on existing water mains for design of water and fire services for the proposed improvements.
3. Fire Protection Site Plan:
 - Preparation of a Fire Protection Site Plan defining the limits of emergency access lanes, and fire protection coverage for the proposed building as required by the International Fire Code, IFC.
4. TDLR Registration/Submittal/Review/Inspection:
 - Submittal of the project site plans for review by the Texas Department of Licensing and Regulations (TDLR). Fees associated with this scope of work are the review and inspection fees from TDLR. Work includes TDLR review of the project documents prior to construction and then following construction, site observations to confirm general conformance of the project with the requirements for ADA accessibility.

5. MEP Design & Construction Services (subconsulted):

- Scope consists of providing an electrical service for up to 11 portables. MEP will coordinate with CPSE to route new overhead lines to the proposed portable location for a pad mounted transformer and provide a main service disconnect switch and a distribution board to serve the portables. Underground conduits will be extended from the existing high school for fire alarm, public address, and technology to the portable location and terminate into an exterior rated pull box to distribute each system to the portables.
- Subconsulted MEP services to perform load analyses, calculations, equipment selections and system design in accordance with applicable building codes, appropriate national standards, and commonly accepted engineering practice. Services shall be rendered for the following building systems in the project:
 - i. Electric Utility Service
 - ii. Power Distribution
 - iii. Fire Alarm Infrastructure
 - iv. Public Address Infrastructure
 - v. Technology Infrastructure
- MEP services include review of contractor's submittals, RFI's and preparation of ASI's when necessary. Services also include up to 3 site visits to observe construction progress and make a general assessment of performance as compared to the requirements of the construction documents.

Excluded from this proposal are the following items:

1. Survey Services;
2. Construction Phase Surveying;
3. Subsurface Utility Engineering (SUE) & Locates;
4. Fire flow calculations and report;
5. Storm water detention design and construction plans;
6. Downstream storm water analysis;
7. Asphalt and/or concrete pavement section design;
8. Geotechnical Engineering;
9. Construction Materials Observation and Testing;
10. Retaining wall design (greater than 4' high);
11. Offsite sanitary sewer and water design;
12. Traffic Control Plan;
13. Demolition plans are excluded.
14. Offsite drainage analysis and/or FEMA flood study;
15. Offsite roadway improvements;
16. Environmental studies;
17. Wetlands determination and/or US Army Corps of Engineers submissions;
18. Water quality treatment facilities design;
19. Electric and gas service easements;
20. LEED or CHPS Certification design or analysis services;
21. Zoning services;
22. Tree Preservation/Landscape/Irrigation Calculations and Design;
23. Services assume site disturbance is limited to less than 1 acre, and no Storm Water Pollution Plan Maintenance Manual will be required.
24. City, County and/or State Fees;
25. Services assume accessible access (ADA) is already provided on the site from nearby parking facilities to the existing building adjacent to the proposed building location.
26. Scope assumes construction contract administration and bidding of project to be done by others and limited construction administration will be required from design team.
27. Revisions to construction plans, or the site plan after calculations are complete due to a redirection by the client, shall be considered an additional service.
28. Any other item not specifically stated to be included as part of the scope of services is excluded.

FEE SUMMARY:**Professional Services:**

1. Limited Construction Documents	\$ 17,500
1. Fire Flow Test (subconsulted)	\$ 800
2. Fire Protection Site Plan	\$ 2,500
3. TDLR Registration/Submittal/Review/Inspection	\$ 3,550
4. <u>MEP Design & Construction Services</u>	\$ 35,200
Total Lump Sum Fees	\$ 59,550

The attached MTR Terms and Conditions are hereby incorporated. Additional services performed for the client which are not outlined in the above description shall be compensated for on an hourly basis in accordance with the attached schedule of hourly rates or through a lump sum fee negotiated with the client. The costs of permits, fees, and construction required by utility companies, City, County and/or State regulatory agencies or departments shall be paid by client. Travel expenses, delivery charges and other incidental costs will be billed separately as reimbursable expenses. Reimbursable expenses are in addition to the above fee arrangement.

If this proposal meets with your approval, please acknowledge such by signing below and returning (fax, scan, or courier) a copy back to our office. Thank you for the opportunity to submit this proposal. If you have any questions or require additional information, please don't hesitate to contact our office.

Sincerely,

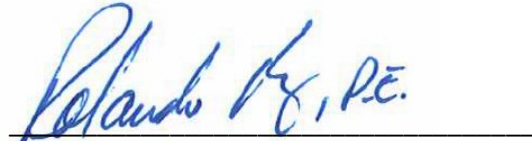

Rolando "Ron" Ramirez, P.E.
Principal

Attachments: MTR Terms and Conditions
MTR Schedule of Hourly Rates

Accepted By:

Signature: _____

Title: _____

Printed Name: _____

Date: _____

TERMS AND CONDITIONS

The Firm shall perform the services outlined in this agreement for the stated fee arrangement.

Access to Site:

Unless otherwise stated, the Firm will have access to the site for activities necessary for the performance of the services. The Firm will take precautions to minimize damage due to these activities, but have not included in the fee the cost of restoration of any resulting damage.

Dispute Resolution:

Any claims or disputes made during design, construction or post-construction between the Client and the Firm shall be submitted in non-binding mediation. Client and Firm agree to include a similar mediation agreement with all contractors, sub contractors, sub consultants, suppliers and fabricators, thereby providing for mediation as the primary method for dispute resolution between all parties.

Billings/Payments:

Invoices for the Firm's services shall be submitted, at the Firm's option, either upon completion of such services or on a monthly basis. Invoices shall be payable within 30 days after the invoice date. If the invoice is not paid within 30 days, the Firm may, without waiving any claim or right against the Client, and without liability whatsoever to the Client, terminate the performance of the service. Retainers shall be credited on the final invoice.

Late Payments:

Accounts unpaid 60 days after the invoice date may be subject to a monthly service charge of 1.5% (or the legal rate) on the then unpaid balance. In the event any portion or all of an account remains unpaid 90 days after billing, the Client shall pay all costs of collection, including reasonable attorney's fees.

Indemnification:

The Client shall, to the fullest extent permitted by law, indemnify and hold harmless the Firm, his or her officers, directors, employees, agents and sub consultants from and against all damage, liability and cost, including reasonable attorney's fees and defense costs, arising out of or in any way connected with the performance by any of the parties above named of the services under this agreement, excepting only those damages, liabilities or costs attributed to the sole negligence or willful misconduct of the Firm.

Certifications, Guarantees and Warranties:

The Firm shall not be required to execute any document that would result in their certifying, guaranteeing or warranting the existence of conditions whose existence the Firm cannot ascertain.

Limitation of Liability:

In recognition of the relative risks, rewards and benefits of the project to both the Client and the Firm, the risks have been allocated such that the Client agrees that, to the fullest extent permitted by law, the Firm's total liability to the Client for any and all injuries, claims, losses, expenses, damages or claim expenses arising out of this agreement from any cause or causes, shall not exceed the total professional services fee paid to the Firm. Such causes include, but are not limited to, the Firm's negligence, errors, omissions, strict liability, breach of contract or breach of warranty.

Termination of Services:

This agreement may be terminated by the Client or the Firm should the other fail to perform its obligations hereunder. In the event of termination, the Client shall pay the Firm for all services rendered to the date of termination, all reimbursable expenses, and reimbursable termination expenses.

Ownership of Documents:

All documents produced by the Firm under this agreement shall remain the property of the Firm and may not be used by the Client for any other endeavor without the written consent of the Firm.

Reimbursable Expenses:

All expenses including mileage, printing, copies, deliveries, fees paid to Jurisdictional Entities, or any other non-direct labor services will be fully reimbursable and are not included in the fee arrangement unless otherwise noted.

Medina Valley Independent School District

Agenda Item Memorandum

To: MVIDS Board of Trustees

Date: February 12, 2024

RE: Consider approving modifications to employment contracts beginning with the 2024-2025 school year.

In accordance with Board Policy DC, DCA, DCB (Legal) and Local), District administration is recommending modifications to the following employment contracts:

- Chapter 21 Term Contracts
- Chapter 21 Probationary Contracts
- Chapter 21 Dual Term Contracts
- Chapter 21 Dual Probationary Contracts
- Non-Chapter 21 Contracts

Administration recommends that the Board approve the recommended employment contract changes to begin in the 2024-2025 school year as presented.

**Dual Assignment
Term Contract**

Employee: _____
Assignments: Certified Classroom Teacher and Coach
Compensation: MVISD Compensation Plan 202 -202
Date given to Employee: _____
Date returned by Employee: _____

The MEDINA VALLEY INDEPENDENT SCHOOL DISTRICT (“District”), acting through its duly elected SCHOOL BOARD (“Board”) hereby employs the above-named professional employee (“Employee”), and Employee accepts employment on the following terms and conditions:

1. **Term.** Employee will be employed on a (#) month basis for the 202 -202 school year, according to the hours and dates set by the District as they exist or may hereafter be amended. The District may extend the end date in a school year to the extent the District adjusts the instructional schedule due to a school or District closing required by disaster, flood, extreme weather conditions, fuel curtailment, epidemic, pandemic, or other calamity. This term contract (“Contract”) assures Employee of a position with the District during the term hereof, but it does not assure Employee of future employment, total salary, and daily rate of pay for future school years. If Employee has not served the required probationary period, this Contract has been given in error, and Employee shall be employed as a probationary contract employee, under the terms and conditions established in the District’s standard probationary contract. The District will provide Employee with start and end dates by the penalty-free resignation date (see Tex. Educ. Code § 21.210).
2. **Credentials.** This Contract is conditioned upon the Employee’s satisfactorily providing, before the first day of instruction, the certification, service records, licenses and other records and information required by state and federal law, the Texas Education Agency (“TEA”), the State Board for Educator Certification (“SBEC”), or the District.
 - 2.1 **Certification:** The Employee agrees to maintain the required certification, permit, or licensure requirements throughout the term of employment with the District and this Contract.
 - 2.2 **Failure to Maintain Certification or Qualifications:** If the Employee fails to fulfill the requirements necessary to extend a temporary or emergency certificate or permit, or the Employee’s certification expires, is canceled, is relinquished, is suspended, or is revoked, the District may provide the Employee with notice that this Contract is void pursuant to Texas Education Code section 21.0031.
3. **Representations.** The Employee makes the following representations and agreements:
 - 3.1 **Criminal History Review:** At the beginning of this Contract, and at any time during this Contract, the Employee specifically agrees to submit to a review of his or her national criminal history record information (“NCHRI”) as required, by law, the District, TEA, and/or SBEC.
 - 3.2 **Beginning of Contract.** The Employee understands that a criminal history record acceptable to the District, at its sole discretion, is a condition of this Contract. The Employee represents that he/she has disclosed to the District, in writing, any indictment, conviction, no contest or guilty plea, deferred adjudication, or other adjudication of the Employee for any felony or any offense listed at 19 Texas Administrative Code § 249.16(c), Policy DH (LOCAL), or an offense involving moral turpitude.
 - 3.3 **During Contract.** The Employee also agrees that, during the term of this Contract, the Employee will notify the Superintendent or designee in writing of any arrest, indictment, conviction, no contest or guilty plea, deferred adjudication, or other adjudication of any criminal offense, including any offense listed at 19 Texas Administrative Code § 249.16(c), or Policy DH (LOCAL). Employee agree to provide such written notification within three (3) calendar days or within any shorter period specified in District policy.
 - 3.4 **False Statements and Misrepresentations.** The Employee represents that any required records or information provided in his or her employment application are true and correct. Any false statements, misrepresentations, omissions of requested information, or fraud by the Employee in or concerning any required records or in the employment application may be grounds for termination or nonrenewal, as applicable.

4. **Duties.** The Employee agrees to perform his or her duties as follows:
- 4.1 **General Standard.** The Employee agrees to perform the duties of the position assigned as prescribed by state and federal law and as may be assigned by the District. The Employee shall perform those duties with reasonable care, skill, and diligence.
- 4.2 **Assignment/Reassignment.** The District shall have the right to assign or reassign the Employee to positions and to make changes in responsibilities, work, transfers, or classification at any time during this Contract term. Employee is, further, subject to the assigned duties and/or directives given to Employee by supervisory personnel. Assigned duties include all those duties necessary to fulfill obligations as a Certified Classroom Teacher and Coach and also includes, but shall not be limited to, attendance at workshops, in-service training and/or staff meetings as may be reasonably required by Employee's supervisor(s), upon reasonable notice to Employee, as well as institutes and meetings called or designated which, in the opinion of the Superintendent, will support sound public school operations. Assigned duties include all those duties necessary to fulfill obligations as a Certified Classroom Teacher and Coach and also includes working from home during a District closure due to a government or Board order. Assigned duties do not include any supplement duty described in Clause 4.3. Employee shall have no property right to any particular position, assignment, campus, duty or title.
- 4.3 **Supplemental Duty.** A supplemental duty is a duty not included in the assignment that is named in this Contract. This Contract does not cover assignments of or payments for supplemental duties. Any such payments for supplemental duties are not included as part of the annual salary under this Contract. This Contract does not create a property right to continued employment in any supplemental duty. Supplemental duties for which the Board has established separate, additional compensation may, from time to time, be requested by Employee and assigned to Employee, subject to the Superintendent's sole discretion. The Superintendent may assign such supplemental duty assignments on an at-will basis as may be agreed upon between Employee and Superintendent, but in no event may such compensation exceed the amount budgeted for the particular extra duty assignment. If Employee is assigned to and agrees to a supplemental duty, the start and end dates for the supplemental duty may be different from the start and end dates under this Contract. Employee has the ability to accept or reject any supplemental duties. If an Employee accepts a supplemental duty, Employee may unilaterally terminate the supplemental duties and said termination shall have no impact on this Contract. The District may also terminate any supplemental duties accepted by Employee and said termination shall have no impact on this Contract. If Employee accepts any supplemental duties, Employee shall execute a separate agreement with the District that shall list the terms and conditions of the supplemental duties.
- 4.4 **Rules:** The Employee shall comply with all Board and District directives, state and federal laws and rules, District policy, and regulations as they exist or may hereafter be amended. Any violation of directives, policies, rules, regulations, or laws are grounds for discipline including termination or nonrenewal as applicable.
- 4.5 **Dual Assignment.** The term "supplemental duty" does not include your dual assignment under this Contract. This Contract constitutes a unified agreement for both your primary assignment and your dual assignment. District action under this Contract concerning either assignment shall constitute the same action for the other assignment. You may not continue employment in one assignment without continuing employment in both assignments and you may not resign one assignment without resigning both.
5. **Compensation.** The District agrees to pay the Employee compensation as follows:
- 5.1 **Salary.** The District shall pay the Employee according to the compensation plan adopted by the Board each school year. The Employee's salary includes consideration for any assigned duties, responsibilities, and tasks as stated in Clauses 4.1 and 4.2; supplemental duties as stated in Clause 4.3 are not covered by this Contract. Compensation of supplemental duties are independent of this Contract. Compensation includes consideration for all assigned duties, responsibilities, and tasks, regardless of the actual number of hours or days, including days not designated on the school calendar, weekends, staff development days and days designated as "holidays" on the District's duty schedule that Employee works during this Contract period, except as provided in the District's supplemental duty schedule for which the Board has established additional compensation. Employee's salary does not include consideration for any supplemental duty. The District shall pay the Employee's salary according to the District's established payroll schedule. Employee shall be

employed according to the hours and workdays of employment set by the District. Hours and workdays may be amended, as needed, or as determined by the District. The Board of Trustees shall authorize payment to Employee, of an annual salary according to the Compensation Plan adopted by the Board as applicable to the Employee based on the Employee's job assignment. In the case of professional employees referred to in Section 21.402, Texas Education Code, compensation shall not be less than the state minimum salary. Employee's salary shall be reduced for absences in excess of authorized paid leave. If Employee is employed after the beginning of the school year, Employee shall be paid a prorated portion of the annual salary in equal installments, tracking the normal District pay cycle, with prorating to be based on the number of workdays remaining in the school year as established by the District. Employee's prorated salary shall be equally divided by the remaining months in this Contract's pay cycle, unless otherwise agreed in writing. In the case of all other employees, compensation shall be solely determined by Employee's placement on the compensation plan adopted by the Board. Placement on the District Compensation Plan is subject to validation of experience and state and/or District certification requirements. Total compensation is subject to modification based on validated experience, degree, certification, and assignment. Errors in calculation shall be corrected and Employee shall reimburse District for wage overpayments because of such errors. Additionally, Employee agrees that the District may deduct any wage overpayments under this Contract from one or more of the Employee's paychecks.

- 5.2 **Furloughs.** If the District implements a furlough under Texas Education Code section 21.4021, Employee's salary will be reduced in proportion to the number of furlough days. The reduction will be equally distributed over the remainder of the applicable school year.
- 5.3 **Annualized Salary.** If the Employee will work on a less than 12-month basis, the Employee's salary will be paid on an annualized basis. The District will make deductions from each paycheck for income tax withholding and benefits.
- 5.4 **Incentive and Performance Pay.** Employee understands that qualifying employees may receive an incentive payment under the District's compensation plan, or any other federal, state or local incentive program. Any incentive payment distributed is considered a payment for performance and not an entitlement as part of the Employee's salary. Employee must meet qualifications, on an annual basis, for incentive pay as set out by State law, Board policy or District procedure. Employee does not have property right to incentive pay and the District may terminate such extra compensation at the end of the school year. If the Employee is suspended with pay and placed on administrative leave by the Superintendent during an investigation of alleged misconduct by the Employee or at any time the Superintendent determines that the District's best interest will be served by the suspension, the Employee will not be eligible for any incentive or performance pay that would have accrued during the suspension period. This provision shall apply regardless of whether the investigation ultimately results in a finding of misconduct or any other adverse action against the Employee. If Employee is terminated or resigns in lieu of termination, Employee shall not be entitled to incentive or performance pay. The Chapter 21 due process rights are not applicable to the termination of incentive pay. If the Employee qualifies, the Employee may receive incentive pay or pay for performance under the District's compensation plan, federal law, or state law, including Education Code Chapter 21, subchapter O.
- 5.5 **Benefits.** The District shall provide benefits to the Employee as provided by state law and Board policy. The District reserves the right to amend its policies at any time during the term of this Contract to reduce or increase these benefits, at the Board's sole discretion.

6. Other Provisions.

- 6.1 **Equipment and Reports.** The Employee shall satisfactorily submit or account for all grades, reports, school equipment, or other required items upon request from the District. The Employee shall comply with all user agreements for District technology. Employee shall be required to use personal equipment, including but not limited to personal cellular phones, personal computers, and personal internet service, when working from home is required during a District closure due to a government or Board order, or when there is an emergency taking place during normal District operations.
- 6.2 **Special Funding.** If your position is funded by grants, federal funding, or other special funding, you understand that your employment is expressly conditioned on the availability of full funding for the position. If full funding becomes unavailable, your employment is subject to termination or nonrenewal, as applicable.

- 6.3 **Addenda.** This Contract does/does not (circle one) include one or more Addenda, as follows:
- (1) Addendum A:
 - (2) Addendum B:
7. **Suspension.** In accordance with Texas Education Code chapter 21, the District may suspend the Employee without pay during the term of this Contract for good cause as determined by the Board.
8. **Termination and Nonrenewal of Contract.**
- 8.1 **Termination.** This Contract will terminate upon:
- 8.1.1. **Good Cause.** A determination by the Board of good cause in accordance with applicable law, including Texas Education Code section 21.211 and Board policy;
 - 8.1.2. **Financial Exigency.** A determination by the Board that a financial exigency requires a reduction in personnel. Unless otherwise defined in local policy, “financial exigency” means any event or occurrence that creates a need for the District to reduce financial expenditures for personnel, including a decline in the District’s financial resources, a decline in enrollment, a cut in funding, a decline in tax revenues, or an unanticipated expense or capital need;
 - 8.1.3. **Program Change.** A determination by the Board that a program change requires termination of the Employee’s Contract. Unless otherwise defined in local policy, “program change” means any elimination, curtailment, or reorganization of a curriculum offering, program, or school operation. “Program change” includes a change in curriculum objectives, a modification or reorganization of staffing patterns on a particular campus or district-wide, a redirection of financial resources to meet the educational needs of the students, a lack of student response to a particular course offering, legislative revisions to programs, or a reorganization or consolidation of two or more individual schools or school districts; or
 - 8.1.4. **Resignation.** The Employee’s resignation at the end of the school year without penalty, pursuant to Texas Education Code Section 21.210.
- 8.2 **Nonrenewal.** The District may nonrenew this Contract in accordance with Texas Education Code Chapter 21, as applicable, and Board policy.
9. **General Provisions.**
- 9.1 **Amendment.** This Contract may not be amended except by written agreement of the parties.
 - 9.2 **Severability.** If any provision in this Contract is, for any reason, held to be invalid, illegal, or unenforceable, such invalidity, illegality, or unenforceability shall not affect any other provision of the Contract. This Contract shall be construed as if such invalid, illegal, or unenforceable provision had never been a part of the Contract, and the other provisions of the Contract will remain in full force and effect.
 - 9.3 **Entire Agreement.** All existing agreements and contracts, both verbal and written, between the parties regarding the employment of the Employee are superseded by this Contract. This Contract, and any addenda, constitutes the entire agreement between the parties. This Contract does not constitute a “unified contract” with any supplemental duties agreement between the parties.
 - 9.4 **Applicable Law.** Texas law shall govern construction of this Contract.
 - 9.5 **Paragraph Headings.** The headings used at the beginning of each numbered paragraph in this Contract are not intended to have any legal effect; the headings do not limit or expand the meaning of the paragraph that follows them.
10. **Notice to Employee.** The Employee agrees to keep a current permanent address and e-mail on file with the District’s human resources office. Unless Texas Education Code chapter 21 requires a different notice delivery method, the Employee agrees that the District may meet any legal obligation it has to give the Employee written notice regarding this Contract or the Employee’s employment by hand-delivering the notice to the Employee or by sending the notice by e-mail, fax, certified mail, regular mail, and/or express delivery service to the Employee’s permanent address of record.
11. **Expiration of Offer.** This offer of employment contract shall expire unless the Employee signs and returns this Contract to the Department of Human Resources on or before (INSERT DATE). Failure to return the signed Contract by this date shall be deemed the Employee’s rejection of this offer of employment contract and the Employee’s resignation from current employment, if any, at the end of the existing contract term.

I have read this Contract and agree to abide by its terms and conditions:

Employee: _____

Date signed: _____

Medina Valley Independent School District

By _____
Superintendent

Date Signed: _____

**Probationary Contract
Chapter 21**

Employee: _____
Assignment: Certified Classroom Teacher
Compensation: MVISD Compensation Plan 202_-202_
Date given to Employee: _____
Date returned by Employee: _____

The MEDINA VALLEY INDEPENDENT SCHOOL DISTRICT (“District”), acting through its duly elected SCHOOL BOARD (“Board”) hereby employs the above-named professional employee (“Employee”), and Employee accepts employment on the following terms and conditions:

1. **Term.** Employee will be employed on a (#) month basis for the 202_-202_ school year, according to the hours and dates set by the District as they exist or may hereafter be amended. The District may extend the end date in a school year to the extent the District adjusts the instructional schedule due to a school or District closing required by disaster, flood, extreme weather conditions, fuel curtailment, epidemic, pandemic, or other calamity. This probationary contract (“Contract”) assures Employee of a position with the District during the term hereof, but it does not assure Employee of future employment, total salary, and daily rate of pay for future school years. The District will provide Employee with start and end dates by the penalty-free resignation date (see Tex. Educ. Code § 21.205). If the effective date of this Contract is after the first day of the school year, no part of service under this Contract shall fulfill any portion of the probationary period defined by Chapter 21.
2. **Credentials.** This Contract is conditioned upon the Employee’s satisfactorily providing, before the first day of instruction, the certification, service records, licenses and other records and information required by state and federal law, the Texas Education Agency (“TEA”), the State Board for Educator Certification (“SBEC”), or the District.
 - 2.1 **Certification:** The Employee agrees to maintain the required certification, permit, or licensure requirements throughout the term of employment with the District and this Contract.
 - 2.2 **Failure to Maintain Certification or Qualifications:** If the Employee fails to fulfill the requirements necessary to extend a temporary or emergency certificate or permit, or the Employee’s certification expires, is canceled, is relinquished, is suspended, or is revoked, the District may provide the Employee with notice that this Contract is void pursuant to Texas Education Code section 21.0031.
3. **Representations.** The Employee makes the following representations and agreements:
 - 3.1 **Criminal History Review:** At the beginning of this Contract, and at any time during this Contract, the Employee specifically agrees to submit to a review of his or her national criminal history record information (“NCHRI”) as required, by law, the District, TEA, and/or SBEC.
 - 3.2 **Beginning of Contract:** The Employee understands that a criminal history record acceptable to the District, at its sole discretion, is a condition of this Contract. The Employee represents that he/she has disclosed to the District, in writing, any indictment, conviction, no contest or guilty plea, deferred adjudication, or other adjudication of the Employee for any felony or any offense listed at 19 Texas Administrative Code § 249.16 (c), policy DH (Local), or an offense involving moral turpitude.
 - 3.3 **During Contract:** The Employee also agrees that, during the term of this Contract, the Employee will notify the Superintendent or designee, in writing, of any arrest, indictment, conviction, no contest or guilty plea, deferred adjudication, or other adjudication of the Employee of any criminal offense, including any offense listed at 19 Texas Administrative Code § 249.16 (c), or policy DH (Local). Employee agrees to provide such written notification within three (3) calendar days, or within any shorter period specified in District policy.
 - 3.4 **False statements and Misrepresentations:** The Employee represents that any required records or information provided in his or her employment application are true and correct. Any false statements, misrepresentations, omissions of requested information, or fraud by the Employee in or concerning any required records or in the employment application may be grounds for termination or nonrenewal, as applicable.
4. **Duties.** The Employee agrees to perform his or her duties as follows:
 - 4.1 **General Standard:** The Employee shall perform the duties of the position assigned as prescribed by state and federal law and as may be assigned by the District. The Employee shall perform those duties with reasonable care, skill, and diligence.
 - 4.2 **Assignment/Reassignment:** The District shall have the right to assign or reassign the Employee to positions and to make changes in responsibilities, work, transfers, or classification at any time during

this Contract term. Employee is, further, subject to the assigned duties and/or directives given to Employee by supervisory personnel. Assigned duties include all those duties necessary to fulfill obligations as a Certified/Professional and also include, but shall not be limited to, attendance at workshops, in-service training and/or staff meetings as may be reasonably required by Employee's supervisor(s), upon reasonable notice to Employee, as well as institutes and meetings called or designated which, in the opinion of the Superintendent, will support sound public school operations. Assigned duties include all those duties necessary to fulfill obligations as a Certified/Professional and also include working from home during a District closure due to a government or Board order. Assigned duties do not include any supplement duty described in Clause 4.3. Employee shall have no property right to any particular position, assignment, campus, duty or title.

4.3 **Supplemental Duty:** A supplemental duty is a duty not included in the assignment that is named in this Contract. This Contract does not cover assignments of or payments for supplemental duties. Any such payments for supplemental duties are not included as part of the annual salary under this Contract. This Contract does not create a property right to continued employment in any supplemental duty. Supplemental duties for which the Board has established separate, additional compensation may, from time to time, be requested by Employee and assigned to Employee, subject to the Superintendent's sole discretion. The Superintendent may assign such supplemental duty assignments on an at-will basis as may be agreed upon between Employee and Superintendent, but in no event may such compensation exceed the amount budgeted for the particular extra duty assignment. If Employee is assigned to and agrees to a supplemental duty, the start and end dates for the supplemental duty may be different from the start and end dates under this Contract. Employee has the ability to accept or reject any supplemental duties. If an Employee accepts a supplemental duty, Employee may unilaterally terminate the supplemental duties and said termination shall have no impact on this Contract. The District may also terminate any supplemental duties accepted by Employee and said termination shall have no impact on this Contract. If Employee accepts any supplemental duties, Employee shall execute a separate agreement with the District that shall list the terms and conditions of the supplemental duties.

4.4 **Rules:** The Employee shall comply with all Board and District directives, state and federal laws and rules, District policy, and regulations as they exist or may hereafter be amended. Any violation of directives, policies, rules, regulations, or laws are grounds for discipline including termination or nonrenewal as applicable.

5. **Compensation.** The District agrees to pay the Employee compensation as follows:

5.1 **Salary:** The District shall pay the Employee according to the compensation plan adopted by the Board each school year. The Employee's salary includes consideration for any assigned duties, responsibilities, and tasks as stated in Clauses 4.1 and 4.2; supplemental duties as stated in Clause 4.3 are not covered by this Contract. Compensation of supplemental duties are independent of this Contract. Compensation includes consideration for all assigned duties, responsibilities, and tasks, regardless of the actual number of hours or days, including days not designated on the school calendar, weekends, staff development days and days designated as "holidays" on the District's duty schedule that Employee works during this Contract period, except as provided in the District's supplemental duty schedule for which the Board has established additional compensation. Employee's salary does not include consideration for any supplemental duty. The District shall pay the Employee's salary according to the District's established payroll schedule. Employee shall be employed according to the hours and workdays of employment set by the District. Hours and workdays may be amended, as needed, or as determined by the District. The Board of Trustees shall authorize payment to Employee, of an annual salary according to the Compensation Plan adopted by the Board as applicable to the Employee based on the Employee's job assignment. In the case of professional employees referred to in Section 21.402, Texas Education Code, compensation shall not be less than the state minimum salary. Employee's salary shall be reduced for absences in excess of authorized paid leave. If Employee is employed after the beginning of the school year, Employee shall be paid a prorated portion of the annual salary in equal installments, tracking the normal District pay cycle, with prorating to be based on the number of workdays remaining in the school year as established by the District. Employee's prorated salary shall be equally divided by the remaining months in this Contract's pay cycle, unless otherwise agreed in writing. In the case of all other employees, compensation shall be solely determined by Employee's placement on the compensation plan adopted by the Board. Placement on the District Compensation Plan is subject to validation of experience and state and/or District certification requirements. Total compensation is subject to modification based on validated experience, degree, certification, and assignment. Errors in calculation shall be corrected and Employee shall reimburse District for wage overpayments because of such errors. Additionally, Employee agrees that the District may deduct any wage overpayments under this Contract from one or more of the Employee's paychecks.

5.2 **Incentive and Performance Pay:** Employee understands that qualifying employees may receive an incentive payment under the District's compensation plan, or any other federal, state or local incentive

program. Any incentive payment distributed is considered a payment for performance and not an entitlement as part of the Employee's salary. Employee must meet qualifications, on an annual basis, for incentive pay as set out by State law, Board policy or District procedure. Employee does not have property right to incentive pay and the District may terminate such extra compensation at the end of the school year. If the Employee is suspended with pay and placed on administrative leave by the Superintendent during an investigation of alleged misconduct by the Employee or at any time the Superintendent determines that the District's best interest will be served by the suspension, the Employee will not be eligible for any incentive or performance pay that would have accrued during the suspension period. This provision shall apply regardless of whether the investigation ultimately results in a finding of misconduct or any other adverse action against the Employee. If Employee is terminated or resigns in lieu of termination, Employee shall not be entitled to incentive or performance pay. The Chapter 21 due process rights are not applicable to the termination of incentive pay. If the Employee qualifies, the Employee may receive incentive pay or pay for performance under the District's compensation plan, federal law, or state law, including Education Code Chapter 21, subchapter O.

- 5.3 **Furloughs:** If the District implements a furlough under Texas Education Code section 21.4021, Employee's salary will be reduced in proportion to the number of furlough days. The reduction will be equally distributed over the remainder of the applicable school year.
- 5.4 **Annualized Salary:** If the Employee will work on a less than 12-month basis, the Employee's salary will be paid on an annualized basis. The District will make deductions from each paycheck for income tax withholding and benefits.
- 5.5 **Benefits:** The District shall provide benefits to the Employee as provided by state law and Board policies. The District reserves the right to amend its policies at any time during the term of this Contract to reduce or increase these benefits, at the Board's sole discretion.

6. **Other Provisions.**

- 6.1 **Equipment and Reports:** The Employee shall satisfactorily submit or account for all grades, reports, school equipment, or other required items upon request from the District. The Employee shall comply with all user agreements for District technology. Employee shall be required to use personal equipment, including but not limited to personal cellular phones, personal computers, and personal internet service, when working from home is required during a District closure due to a government or Board order, or when there is an emergency taking place during normal District operations.
- 6.2 **Special Funding:** Employment in federally or categorically funded positions is expressly conditioned on the availability of full funding for the position. If full funding becomes unavailable, the Employee is subject to termination or nonrenewal, as applicable.
- 6.3 **Addenda.** This Contract does/does not (circle one) include one or more Addenda, as follows:

- (1) Addendum A:
- (2) Addendum B:

7. **Suspension.** In accordance with Texas Education Code, Chapter 21, the District may suspend the Employee without pay during the term of this Contract for good cause as determined by the Board.

8. **Termination of Contract.**

- 8.1 **Termination:** This Contract will terminate, in accordance with the procedures at Texas Education Code chapter 21, if the Board determines that termination of the Employee's Contract at the end of the Contract period will serve the best interests of the District, or if the Board determines that any of the following exists: good cause, financial exigency, or a program change. This Contract will also terminate if the Employee provides written notice of resignation before the penalty-free resignation date (see Tex. Educ. Code section 21.105).

9. **General Provisions.**

- 9.1 **Amendment:** This Contract may not be amended except by written agreement of the parties.
- 9.2 **Severability:** If any provision in this Contract is, for any reason, held to be invalid, illegal, or unenforceable, such invalidity, illegality, or unenforceability shall not affect any other provision of the Contract. This Contract shall be construed as if such invalid, illegal, or unenforceable provision had never been a part of the Contract, and the other provisions of the Contract will remain in full force and effect.
- 9.3 **Entire Agreement:** All existing agreements and contracts, both verbal and written, between the parties regarding the employment of the Employee are superseded by this Contract. This Contract, and any addenda, constitutes the entire agreement between the parties. This Contract does not constitute a "unified contract" with any supplemental duties agreement between the parties.
- 9.4 **Applicable Law:** Texas law shall govern construction of this Contract.

9.5 **Paragraph Headings:** The headings used at the beginning of each numbered paragraph in this Contract are not intended to have any legal effect; the headings do not limit or expand the meaning of the paragraphs that follow them.

10. **Notice to Employee.** The Employee agrees to keep a current permanent address and e-mail address on file with the District's Personnel office. Unless Texas Education Code chapter 21 requires a different notice delivery method, the Employee agrees that the District may meet any legal obligation it has to give the Employee written notice regarding this Contract or the Employee's employment by hand-delivering the notice to the Employee or by sending the notice by e-mail, fax, certified mail, regular mail, and/or express delivery service to the Employee's permanent address of record.
11. **Expiration of Offer.** This offer of employment contract shall expire unless the Employee signs and returns this Contract to the Department of Human Resources Department on or before (INSERT DATE). Failure to return the signed Contract by this date shall be deemed the Employee's rejection of this offer of employment contract and the Employee's resignation from current employment, if any, at the end of the existing contract term.

I have read this Contract and agree to abide by its terms and conditions:

Employee: _____

Date signed: _____

Medina Valley Independent School District

By: _____
Superintendent

Date Signed: _____

**One Year Term Contract
Chapter 21**

Employee: _____
Assignment: Certified Classroom Teacher
Compensation: MVISD Compensation Plan 2024-2025
Date given to Employee: _____
Date returned by Employee: _____

The MEDINA VALLEY INDEPENDENT SCHOOL DISTRICT (“District”), acting through its duly elected SCHOOL BOARD (“Board”) hereby employs the above-named professional employee (“Employee”), and Employee accepts employment on the following terms and conditions:

1. **Term.** Employee will be employed on a (10) month basis for the 2024-2025 school year, according to the hours and dates set by the District as they exist or may hereafter be amended. The District may extend the end date in a school year to the extent the District adjusts the instructional schedule due to a school or District closing required by disaster, flood, extreme weather conditions, fuel curtailment, epidemic, pandemic, or other calamity. This term contract (“Contract”) assures Employee of a position with the District during the term hereof, but it does not assure Employee of future employment, total salary, and daily rate of pay for future school years. If Employee has not served the required probationary period, this Contract has been given in error, and Employee shall be employed as a probationary contract employee, under the terms and conditions established in the District’s standard probationary contract. The District will provide Employee with start and end dates by the penalty-free resignation date (see Tex. Educ. Code § 21.210).
2. **Credentials.** This Contract is conditioned upon the Employee’s satisfactorily providing, before the first day of instruction, the certification, service records, licenses and other records and information required by state and federal law, the Texas Education Agency (“TEA”), the State Board for Educator Certification (“SBEC”), or the District.
 - 2.1 **Certification:** The Employee agrees to maintain the required certification, permit, or licensure requirements throughout the term of employment with the District and this Contract.
 - 2.2 **Failure to Maintain Certification or Qualifications:** If the Employee fails to fulfill the requirements necessary to extend a temporary or emergency certificate or permit, or the Employee’s certification expires, is canceled, is relinquished, is suspended, or is revoked, the District may provide the Employee with notice that this Contract is void pursuant to Texas Education Code section 21.0031.
3. **Representations.** The Employee makes the following representations and agreements:
 - 3.1 **Criminal History Review:** At the beginning of this Contract, and at any time during this Contract, the Employee specifically agrees to submit to a review of his or her national criminal history record information (“NCHRI”) as required, by law, the District, TEA, and/or SBEC.
 - 3.2 **Beginning of Contract.** The Employee understands that a criminal history record acceptable to the District, at its sole discretion, is a condition of this Contract. The Employee represents that he/she has disclosed to the District, in writing, any indictment, conviction, no contest or guilty plea, deferred adjudication, or other adjudication of the Employee for any felony or any offense listed at 19 Texas Administrative Code § 249.16(c), Policy DH (LOCAL), or an offense involving moral turpitude.
 - 3.3 **During Contract.** The Employee also agrees that, during the term of this Contract, the Employee will notify the Superintendent or designee in writing of any arrest, indictment, conviction, no contest or guilty plea, deferred adjudication, or other adjudication of any criminal offense, including any offense listed at 19 Texas Administrative Code § 249.16(c), or Policy DH (LOCAL). The Employee agrees to provide such written notification within three (3) calendar days or within any shorter period specified in District policy.
 - 3.4 **False Statements and Misrepresentations.** The Employee represents that any required records or information provided in his or her employment application are true and correct. Any false statements, misrepresentations, omissions of requested information, or fraud by the Employee in or

concerning any required records or in the employment application may be grounds for termination or nonrenewal, as applicable.

4. **Duties.** The Employee agrees to perform his or her duties as follows:
 - 4.1 **General Standard.** The Employee agrees to perform the duties of the position assigned as prescribed by state and federal law and as may be assigned by the District. The Employee shall perform those duties with reasonable care, skill, and diligence.
 - 4.2 **Assignment/Reassignment.** The District shall have the right to assign or reassign the Employee to positions and to make changes in responsibilities, work, transfers, or classification at any time during this Contract term. Employee is, further, subject to the assigned duties and/or directives given to Employee by supervisory personnel. Assigned duties include all those duties necessary to fulfill obligations as a Certified/Professional and also include, but shall not be limited to, attendance at workshops, in-service training and/or staff meetings as may be reasonably required by Employee's supervisor(s), upon reasonable notice to Employee, as well as institutes and meetings called or designated which, in the opinion of the Superintendent, will support sound public school operations. Assigned duties include all those duties necessary to fulfill obligations as a Certified/Professional and also include working from home during a District closure due to a government or Board order. Assigned duties do not include any supplement duty described in Clause 4.3. Employee shall have no property right to any particular position, assignment, campus, duty or title.
 - 4.3 **Supplemental Duty.** A supplemental duty is a duty not included in the assignment that is named in this Contract. This Contract does not cover assignments of or payments for supplemental duties. Any such payments for supplemental duties are not included as part of the annual salary under this Contract. This Contract does not create a property right to continued employment in any supplemental duty. Supplemental duties for which the Board has established separate, additional compensation may, from time to time, be requested by Employee and assigned to Employee, subject to the Superintendent's sole discretion. The Superintendent may assign such supplemental duty assignments on an at-will basis as may be agreed upon between Employee and Superintendent, but in no event may such compensation exceed the amount budgeted for the particular extra duty assignment. If Employee is assigned to and agrees to a supplemental duty, the start and end dates for the supplemental duty may be different from the start and end dates under this Contract. Employee has the ability to accept or reject any supplemental duties. If an Employee accepts a supplemental duty, Employee may unilaterally terminate the supplemental duties and said termination shall have no impact on this Contract. The District may also terminate any supplemental duties accepted by Employee and said termination shall have no impact on this Contract. If Employee accepts any supplemental duties, Employee shall execute a separate agreement with the District that shall list the terms and conditions of the supplemental duties.
 - 4.4 **Rules:** The Employee shall comply with all Board and District directives, state and federal laws and rules, District policy, and regulations as they exist or may hereafter be amended. Any violation of directives, policies, rules, regulations, or laws are grounds for discipline including termination or nonrenewal as applicable.
5. **Compensation.** The District agrees to pay the Employee compensation as follows:
 - 5.1 **Salary.** The District shall pay the Employee according to the compensation plan adopted by the Board each school year. The Employee's salary includes consideration for any assigned duties, responsibilities, and tasks as stated in Clauses 4.1 and 4.2; supplemental duties as stated in Clause 4.3 are not covered by this Contract. Compensation of supplemental duties are independent of this Contract. Compensation includes consideration for all assigned duties, responsibilities, and tasks, regardless of the actual number of hours or days, including days not designated on the school calendar, weekends, staff development days and days designated as "holidays" on the District's duty schedule that Employee works during this Contract period, except as provided in the District's supplemental duty schedule for which the Board has established additional compensation. Employee's salary does not include consideration for any supplemental duty. The District shall pay the Employee's salary according to the District's established payroll schedule. Employee shall be employed according to the hours and workdays of employment set by the District. Hours and workdays may be amended, as needed, or as determined by the District. The Board of Trustees shall authorize payment to Employee, of an annual salary according to the Compensation Plan

adopted by the Board as applicable to the Employee based on the Employee's job assignment. In the case of professional employees referred to in Section 21.402, Texas Education Code, compensation shall not be less than the state minimum salary. Employee's salary shall be reduced for absences in excess of authorized paid leave. If Employee is employed after the beginning of the school year, Employee shall be paid a prorated portion of the annual salary in equal installments, tracking the normal District pay cycle, with prorating to be based on the number of workdays remaining in the school year as established by the District. Employee's prorated salary shall be equally divided by the remaining months in this Contract's pay cycle, unless otherwise agreed in writing. In the case of all other employees, compensation shall be solely determined by Employee's placement on the compensation plan adopted by the Board. Placement on the District Compensation Plan is subject to validation of experience and state and/or District certification requirements. Total compensation is subject to modification based on validated experience, degree, certification, and assignment. Errors in calculation shall be corrected and Employee shall reimburse District for wage overpayments because of such errors. Additionally, Employee agrees that the District may deduct any wage overpayments under this Contract from one or more of the Employee's paychecks.

- 5.2 **Furloughs.** If the District implements a furlough under Texas Education Code section 21.4021, Employee's salary will be reduced in proportion to the number of furlough days. The reduction will be equally distributed over the remainder of the applicable school year.
- 5.3 **Annualized Salary.** If the Employee will work on a less than 12-month basis, the Employee's salary will be paid on an annualized basis. The District will make deductions from each paycheck for income tax withholding and benefits.
- 5.4 **Incentive and Performance Pay.** Employee understands that qualifying employees may receive an incentive payment under the District's compensation plan, or any other federal, state or local incentive program. Any incentive payment distributed is considered a payment for performance and not an entitlement as part of the Employee's salary. Employee must meet qualifications, on an annual basis, for incentive pay as set out by State law, Board policy or District procedure. Employee does not have property right to incentive pay and the District may terminate such extra compensation at the end of the school year. If the Employee is suspended with pay and placed on administrative leave by the Superintendent during an investigation of alleged misconduct by the Employee or at any time the Superintendent determines that the District's best interest will be served by the suspension, the Employee will not be eligible for any incentive or performance pay that would have accrued during the suspension period. This provision shall apply regardless of whether the investigation ultimately results in a finding of misconduct or any other adverse action against the Employee. If Employee is terminated or resigns in lieu of termination, Employee shall not be entitled to incentive or performance pay. The Chapter 21 due process rights are not applicable to the termination of incentive pay. If the Employee qualifies, the Employee may receive incentive pay or pay for performance under the District's compensation plan, federal law, or state law, including Education Code Chapter 21, subchapter O.
- 5.5 **Benefits.** The District shall provide benefits to the Employee as provided by state law and Board policy. The District reserves the right to amend its policies at any time during the term of this Contract to reduce or increase these benefits, at the Board's sole discretion.

6. **Other Provisions.**

- 6.1 **Equipment and Reports.** The Employee shall satisfactorily submit or account for all grades, reports, school equipment, or other required items upon request from the District. The Employee shall comply with all user agreements for District technology. Employee shall be required to use personal equipment, including but not limited to personal cellular phones, personal computers, and personal internet service, when working from home is required during a District closure due to a government or Board order, or when there is an emergency taking place during normal District operations.
- 6.2 **Special Funding.** If your position is funded by grants, federal funding, or other special funding, you understand that your employment is expressly conditioned on the availability of full funding for the position. If full funding becomes unavailable, your employment is subject to termination or nonrenewal, as applicable.
- 6.3 **Addenda.** This Contract does/does not (circle one) include one or more Addenda, as follows:

- (1) Addendum A:

(2) Addendum B:

7. **Suspension.** In accordance with Texas Education Code chapter 21, the District may suspend the Employee without pay during the term of this Contract for good cause as determined by the Board.

8. **Termination and Nonrenewal of Contract.**

8.1 **Termination.** This Contract will terminate upon:

8.1.1. **Good Cause.** A determination by the Board of good cause in accordance with applicable law, including Texas Education Code section 21.211 and Board policy;

8.1.2. **Financial Exigency.** A determination by the Board that a financial exigency requires a reduction in personnel. Unless otherwise defined in local policy, “financial exigency” means any event or occurrence that creates a need for the District to reduce financial expenditures for personnel, including a decline in the District’s financial resources, a decline in enrollment, a cut in funding, a decline in tax revenues, or an unanticipated expense or capital need;

8.1.3. **Program Change.** A determination by the Board that a program change requires termination of the Employee’s Contract. Unless otherwise defined in local policy, “program change” means any elimination, curtailment, or reorganization of a curriculum offering, program, or school operation. “Program change” includes a change in curriculum objectives, a modification or reorganization of staffing patterns on a particular campus or district-wide, a redirection of financial resources to meet the educational needs of the students, a lack of student response to a particular course offering, legislative revisions to programs, or a reorganization or consolidation of two or more individual schools or school districts; or

8.1.4. **Resignation.** The Employee’s resignation at the end of the school year without penalty, pursuant to Texas Education Code Section 21.210.

8.2 **Nonrenewal.** The District may nonrenew this Contract in accordance with Texas Education Code Chapter 21, as applicable, and Board policy.

9. **General Provisions.**

9.1 **Amendment.** This Contract may not be amended except by written agreement of the parties.

9.2 **Severability.** If any provision in this Contract is, for any reason, held to be invalid, illegal, or unenforceable, such invalidity, illegality, or unenforceability shall not affect any other provision of the Contract. This Contract shall be construed as if such invalid, illegal, or unenforceable provision had never been a part of the Contract, and the other provisions of the Contract will remain in full force and effect.

9.3 **Entire Agreement.** All existing agreements and contracts, both verbal and written, between the parties regarding the employment of the Employee are superseded by this Contract. This Contract, and any addenda, constitutes the entire agreement between the parties. This Contract does not constitute a “unified contract” with any supplemental duties agreement between the parties.

9.4 **Applicable Law.** Texas law shall govern construction of this Contract.

9.5 **Paragraph Headings.** The headings used at the beginning of each numbered paragraph in this Contract are not intended to have any legal effect; the headings do not limit or expand the meaning of the paragraph that follows them.

10. **Notice to Employee.** The Employee agrees to keep a current permanent address and e-mail on file with the District’s human resources office. Unless Texas Education Code chapter 21 requires a different notice delivery method, the Employee agrees that the District may meet any legal obligation it has to give the Employee written notice regarding this Contract or the Employee’s employment by hand-delivering the notice to the Employee or by sending the notice by e-mail, fax, certified mail, regular mail, and/or express delivery service to the Employee’s permanent address of record.

11. **Expiration of Offer.** This offer of employment contract shall expire unless the Employee signs and returns this Contract to the Department of Human Resources on or before **(INSERT DATE)**. Failure to return the signed Contract by this date shall be deemed the Employee’s rejection of this offer of employment contract and the Employee’s resignation from current employment, if any, at the end of the existing contract term.

I have read this Contract and agree to abide by its terms and conditions:

Employee: _____

Date signed: _____

Medina Valley Independent School District

By: _____
Superintendent of Schools

Date signed: _____

Noncertified Professional/ Non-Chapter 21 Contract	Employee:	NAME/ ID# _____
	Assignment:	<u>NONCERTIFIED PROFESSIONAL</u>
	Compensation:	<u>MVISD Compensation Plan 202 -202</u>
	Date given to Employee:	_____
	Date returned by Employee:	_____

The MEDINA VALLEY INDEPENDENT SCHOOL DISTRICT (“District”), acting through its duly elected SCHOOL BOARD (“Board”) hereby employs the above-named professional employee (“Employee”), and Employee accepts employment on the following terms and conditions:

1. **Term.** Employee will be employed on a (#) month basis for the 202_-202_ school year, according to the hours and dates set by the District as they exist or may hereafter be amended. The District may extend the end date in a school year to the extent the District adjusts the instructional schedule due to a school or District closing required by disaster, flood, extreme weather conditions, fuel curtailment, epidemic, pandemic, or other calamity. This contract (“Contract”) assures Employee of a position with the District during the term hereof, but it does not assure Employee of future employment, total salary, and daily rate of pay for future school years.
2. **Credentials.** The Employee shall maintain the following credentials:
 - 2.1 **Documentation:** If your position requires that you be certified or licensed, you agree to provide, before your start date each school year, the credentials and other records required by law, the Texas Education Agency (“TEA”), the State Board for Educator Certification (“SBEC”), or the District. You agree to maintain any required certification, permit, or licensure requirements throughout the term of this Contract. If you fail to fulfill the requirements necessary to extend a temporary or emergency certificate or permit, or if your certification or permit expires, is relinquished, is cancelled, is suspended, or is revoked, the District may provide you with notice that this Contract is void.
 - 2.2 **Teaching Permit:** If you are to be employed under a local district teaching permit, this Contract is conditioned upon your maintaining the local district teaching permit throughout the term of the Contract.
3. **Representations.** The Employee makes the following representations and agreements:
 - 3.1 **Criminal History Review:** At the beginning of this Contract, and at any time during this Contract, the Employee specifically agrees to submit to a review of his or her national criminal history record information (“NCHRI”) as required, by law, the District, TEA, and/or SBEC.
 - 3.2 **Beginning of Contract.** The Employee agrees that a criminal history record acceptable to the District, at its sole discretion, is a condition of this Contract. The Employee represents that he/she have disclosed to the District, in writing, any indictment, conviction, no contest or guilty plea, deferred adjudication, or other adjudication of the Employee for any felony or any offense listed at 19 Texas Administrative Code § 249.16(c), Policy DH (LOCAL), or an offense involving moral turpitude.
 - 3.3 **During Contract.** The Employee also agrees that, during the term of this Contract, the Employee will notify the Superintendent or designee in writing of any arrest, indictment, conviction, no contest or guilty plea, deferred adjudication, or other adjudication of any criminal offense, including any offense listed at 19 Texas Administrative Code § 249.16(c), or Policy DH (LOCAL). The Employee agrees to provide such written notification within three (3) calendar days or within any shorter period specified in District policy.
 - 3.4 **False Statements and Misrepresentations.** The Employee represents that any required records or information his or her employment application are true and correct. Any false statements, misrepresentations, omissions of requested information, or fraud by the Employee in or concerning any required records or in the employment application may be grounds for termination.

4. **Duties.** The Employee agrees to perform his or her duties as follows:
 - 4.1 **General Standard.** The Employee agrees to perform the duties of the position assigned as prescribed by state and federal law and as may be assigned by the District. The Employee shall perform those duties with reasonable care, skill, and diligence.
 - 4.2 **Assignment/Reassignment.** The District shall have the right to assign or reassign the Employee to positions and to make changes in responsibilities, work, transfers, or classification at any time during this Contract term. Employee is, further, subject to the assigned duties and/or directives given to Employee by supervisory personnel. Assigned duties include all those duties necessary to fulfill obligations of a Noncertified Professional and also include, but shall not be limited to, attendance at workshops, in-service training and/or staff meetings as may be reasonably required by Employee's supervisor(s), upon reasonable notice to Employee, as well as institutes and meetings called or designated which, in the opinion of the Superintendent, will support sound public school operations. Assigned duties include all those duties necessary to fulfill obligations as a Noncertified Professional and also include working from home during a District closure due to a government or Board order. Assigned duties do not include any supplement duty described in Clause 4.3. Employee shall have no property right to any particular position, assignment, campus, duty or title.
 - 4.3 **Supplemental Duty.** A supplemental duty is a duty not included in the assignment that is named in this Contract. This Contract does not cover assignments of or payments for supplemental duties. Any such payments for supplemental duties are not included as part of the annual salary under this Contract. This Contract does not create a property right to continued employment in any supplemental duty. Supplemental duties for which the Board has established separate, additional compensation may, from time to time, be requested by Employee and assigned to Employee, subject to the Superintendent's sole discretion. The Superintendent may assign such supplemental duty assignments on an at-will basis as may be agreed upon between Employee and Superintendent, but in no event may such compensation exceed the amount budgeted for the particular extra duty assignment. If Employee is assigned to and agrees to a supplemental duty, the start and end dates for the supplemental duty may be different from the start and end dates under this Contract. Employee has the ability to accept or reject any supplemental duties. If an Employee accepts a supplemental duty, Employee may unilaterally terminate the supplemental duties and said termination shall have no impact on this Contract. The District may also terminate any supplemental duties accepted by Employee and said termination shall have no impact on this Contract. If Employee accepts any supplemental duties, Employee shall execute a separate agreement with the District that shall list the terms and conditions of the supplemental duties.
 - 4.4 **Rules:** The Employee shall comply with all Board and District directives, state and federal laws and rules, District policy, and regulations as they exist or may hereafter be amended. Any violation of directives, policies, rules, regulations, or laws are grounds for discipline including termination.
5. **Compensation.** The District agrees to pay the Employee compensation as follows:
 - 5.1 **Salary.** The District shall pay the Employee according to the compensation plan adopted by the Board each school year. The Employee's salary includes consideration for any assigned duties, responsibilities, and tasks as stated in Clauses 4.1 and 4.2; supplemental duties as stated in Clause 4.3 are not covered by this Contract. Compensation of supplemental duties are independent of this Contract. Compensation includes consideration for all assigned duties, responsibilities, and tasks, regardless of the actual number of hours or days, including days not designated on the school calendar, weekends, staff development days and days designated as "holidays" on the District's duty schedule that Employee works during this Contract period, except as provided in the District's supplemental duty schedule for which the Board has established additional compensation. Employee's salary does not include consideration for any supplemental duty. The District shall pay the Employee's salary according to the District's established payroll schedule. Employee shall be employed according to the hours and workdays of employment set by the District. Hours and workdays may be amended, as needed, or as determined by the District. The Board of Trustees shall authorize payment to Employee, of an annual salary according to the Compensation Plan adopted by the Board as applicable to the Employee based on the Employee's job assignment. Employee's salary shall be reduced for absences in excess of authorized paid leave. If Employee is employed after the beginning of the school year, Employee shall be paid a prorated portion of the annual salary

in equal installments, tracking the normal District pay cycle, with prorating to be based on the number of workdays remaining in the school year as established by the District. Employee's prorated salary shall be equally divided by the remaining months in this Contract's pay cycle, unless otherwise agreed in writing. In the case of all other employees, the Employee's compensation shall be solely determined by Employee's placement on the compensation plan adopted by the Board. Placement on the District Compensation Plan is subject to validation of experience and state and/or District certification requirements. Total compensation is subject to modification based on validated experience, degree, certification, and assignment. Errors in calculation shall be corrected and Employee shall reimburse District for wage overpayments because of such errors. Additionally, Employee agrees that the District may deduct any wage overpayments under this Contract from one or more of the Employee's paychecks.

- 5.2 **Furloughs.** If the District implements a furlough under Texas Education Code section 21.4021, Employee's salary will be reduced in proportion to the number of furlough days. The reduction will be equally distributed over the remainder of the applicable school year.
- 5.3 **Annualized Salary.** If the Employee will work on a less than 12-month basis, the Employee's salary will be paid on an annualized basis. The District will make deductions from each paycheck for income tax withholding and benefits.
- 5.4 **Incentive and Performance Pay.** Employee understands that qualifying employees may receive an incentive payment under the District's compensation plan, or any other federal, state or local incentive program. Any incentive payment distributed is considered a payment for performance and not an entitlement as part of the Employee's salary. Employee must meet qualifications, on an annual basis, for incentive pay as set out by State law, Board policy or District procedure. Employee does not have property right to incentive pay and the District may terminate such extra compensation at the end of the school year. If the Employee is suspended with pay and placed on administrative leave by the Superintendent during an investigation of alleged misconduct by the Employee or at any time the Superintendent determines that the District's best interest will be served by the suspension, the Employee will not be eligible for any incentive or performance pay that would have accrued during the suspension period. This provision shall apply regardless of whether the investigation ultimately results in a finding of misconduct or any other adverse action against the Employee. If Employee is terminated or resigns in lieu of termination, Employee shall not be entitled to incentive or performance pay. If the Employee qualifies, the Employee may receive incentive pay or pay for performance under the District's compensation plan, federal law, or state law, including Education Code Chapter 21, subchapter O.
- 5.5 **Benefits.** The District shall provide benefits to the Employee as provided by state law and Board policy. The District reserves the right to amend its policies at any time during the term of this Contract to reduce or increase these benefits, at the Board's sole discretion.
- 5.6 **Overpayments.** You agree that you are not entitled to any fund the District overpays you and you further agree that the District may deduct any overpayments under this Contract from one or more of your paychecks.

6. Other Provisions.

- 6.1 **Equipment and Reports.** The Employee shall satisfactorily submit or account for all grades, reports, school equipment, or other required items upon request from the District. The Employee shall comply with all user agreements for District technology. Employee shall be required to use personal equipment, including but not limited to personal cellular phones, personal computers, and personal internet service, when working from home is required during a District closure due to a government or Board order, or when there is an emergency taking place during normal District operations.
- 6.2 **Special Funding.** If your position is funded by grants, federal funding, or other special funding, you understand that your employment is expressly conditioned on the availability of full funding for the position. If full funding becomes unavailable, your employment is subject to termination or nonrenewal, as applicable.
- 6.3 **Addenda.** This Contract does/does not (circle one) include one or more Addenda, as follows:

- (1) Addendum A:
- (2) Addendum B:

7. **Suspension.** This contract is not governed by the suspension provisions of the Texas Education Code Chapter 21.
 - 7.1 The District may suspend you, with pay, at any time during this Contract at the District’s sole discretion. The District may suspend you without pay during the term of this Contract for good cause as determined by the Board.

8. **Termination and Nonrenewal of Contract.**
 - 8.1 **Termination.** This Contract is not governed by the termination and nonrenewal provisions of Texas Education Code Chapter 21. This Contract will terminate at the end of the Contract term, or upon a determination by the Board of any of the following: good cause, financial exigency, or program change. You may resign during the Contract term only with the consent of the Board or designee.
 - 8.2 **Renewal and Nonrenewal:** This Contract is not governed by the renewal and the nonrenewal provisions of Texas Education Code Chapter 21. **This Contract does not give the Employee any rights to the procedures required by Texas Education Code Chapter 21 or to any property rights in employment beyond the Contract term.**

9. **General Provisions.**
 - 9.1 **Amendment.** This Contract may not be amended except by written agreement of the parties.
 - 9.2 **Severability.** If any provision in this Contract is, for any reason, held to be invalid, illegal, or unenforceable, such invalidity, illegality, or unenforceability shall not affect any other provision of the Contract. **This Contract shall be construed as if such invalid, illegal, or unenforceable provision had never been a part of the Contract, and the other provisions of the Contract will remain in full force and effect.**
 - 9.3 **Entire Agreement.** All existing agreements and contracts, both verbal and written, between the parties regarding the employment of the Employee are superseded by this Contract. This Contract, and any addenda, constitutes the entire agreement between the parties. This Contract does not constitute a “unified contract” with any supplemental duties agreement between the parties.
 - 9.4 **Applicable Law.** Texas law shall govern construction of this Contract.
 - 9.5 **Paragraph Headings.** The headings used at the beginning of each numbered paragraph in this Contract are not intended to have any legal effect; the headings do not limit or expand the meaning of the paragraph that follows them.

10. **Notice to Employee.** The Employee agrees to keep a current, permanent address and e-mail on file with the District’s human resources office. Unless law or policy requires a different notice delivery method, the Employee agrees that the District may meet any legal obligation it has to give the Employee written notice regarding this Contract or the Employee’s employment by hand-delivering the notice to the Employee or by sending the notice by e-mail, fax, certified mail, regular mail, and/or express delivery service to the Employee’s permanent address of record.

11. **Expiration of Offer.** This offer of employment contract shall expire unless you sign and return this Contract, without changes, to the Superintendent or designee on or before _____2024. Failure to return the signed Contract by this date shall be deemed the Employee’s rejection of this offer of employment contract and the Employee’s resignation from current employment, if any, at the end of the existing contract term.

I have read this Contract and agree to abide by its terms and conditions:

Employee: _____

Date signed: _____

Medina Valley Independent School District

By: *Beth Zinsmeyer*
 President, Board of Trustees

Date signed: _____

Medina Valley Independent School District

Agenda Item Memorandum

To: MVISD Board of Trustees

Date: February 26, 2024

RE: Consider adopting resolution related to Senate Bill 763.

Beginning in 2023-2024, Senate Bill 763 allows school districts to employ chaplains or accept chaplains as volunteers for providing students support, services, and programs assigned by the board. The bill requires every school board to take a record vote by March 1, 2024, on whether to adopt a policy authorizing chaplains as employees or volunteers.

District Administration is recommending the adoption of a Resolution that does not permit a District campus to employ or accept as a volunteer a chaplain to provide support, services, and programs for students, at this time.

Resolution Of The Medina Valley Independent School District Board Of Trustees Regarding Adoption of A Policy Authorizing A Campus Of The District To Employ Or Accept As A Volunteer A Chaplain Under Chapter 23 Of The Texas Education Code

WHEREAS, Section 23.001 of the Texas Education Code permits the District to employ or accept as a volunteer a chaplain to provide support, services, and programs for students as assigned by the Board;

WHEREAS, Senate Bill 763, passed by the 88th Texas Legislature, requires each school board to take a record vote between September 1, 2023, and March 1, 2024, on whether to adopt a policy authorizing a campus of the District to employ or accept as a volunteer a chaplain under Education Code Chapter 23;

NOW, THEREFORE, BE IT RESOLVED that the Board of Trustees of the Medina Valley Independent School District hereby:

Does not permit a District campus to employ or accept as a volunteer a chaplain to provide support, services, and programs for students, at this time.

Adopted this 26th day of February 2024, by the Medina Valley Independent School District Board of Trustees.

President, Board of Trustees

ATTEST:

Secretary, Board of Trustees

Medina Valley Independent School District

Agenda Item Memorandum

To: MVISD Board of Trustees

Date: February 26, 2024

RE: Consider Adoption of the Medina Valley ISD Good Governance Handbook

The Medina Valley ISD's Good Governance Handbook was developed with guidance from MoakCasey's Board Development workshops. Board Workshops were conducted with Greg Gibson (MoakCasey) presenting on 11/07/2022, 01/17/2023, and 09/13/2023. The focus of the workshops was Good Governance Team Building, Short and Long Term Strategic Planning, the development of the Balanced Scorecard Template, and plans for the Good Governance Handbook.

After multiple revisions and reviews by Board Members, the Board is ready to consider this document for adoption.

Medina Valley Independent School District

Board of Trustees
Good Governance Handbook



MVISD 2023–2024 Board of Trustees and Superintendent

President

Beth Zinsmeyer
Single Member District 2, Term Expires 5/2024

Vice President

Matthew Castiglione
Single Member District 3, Term Expires 5/2025

Secretary

Jennilea Campbell
Single Member District 4, Term Expires 5/2025

Board Member

Veronica Cavazos
Single Member District 1, Term Expires 5/2024

Board Member

Jason Bonney
Single Member District 5, Term expires 5/2026

Board Member

Nathan Fillinger
At-Large, Term Expires 5/2026

Board Member

Blane Nash
At-Large, Term Expires 5/2026

Superintendent of Schools

Scott Caloss, Ed.D.

The Medina Valley ISD Board of Trustees is committed to operating under Good Governance with the continued development of a system that supports and models the *Three Essential Roles*. The Board's role is to oversee District operations from the Strategic Role while striving to support the Tactical and Operational Roles.

The MVISD Board of Trustees in conjunction with the Superintendent will utilize the District's Balanced Scorecard as a model for continuous improvement and oversight in all areas.

In addition to adherence to and support of the Three Essential Roles, the Board will strive for excellence in Good Governance by committing to the norms which were developed as a Team of Eight in the Spring of 2023.

MOAK, CASEY & ASSOCIATES
 Strategic Thought, Design and Continuous Improvement
THREE ESSENTIAL ROLES IN AN ALIGNED SCHOOL SYSTEM
Strategic Role

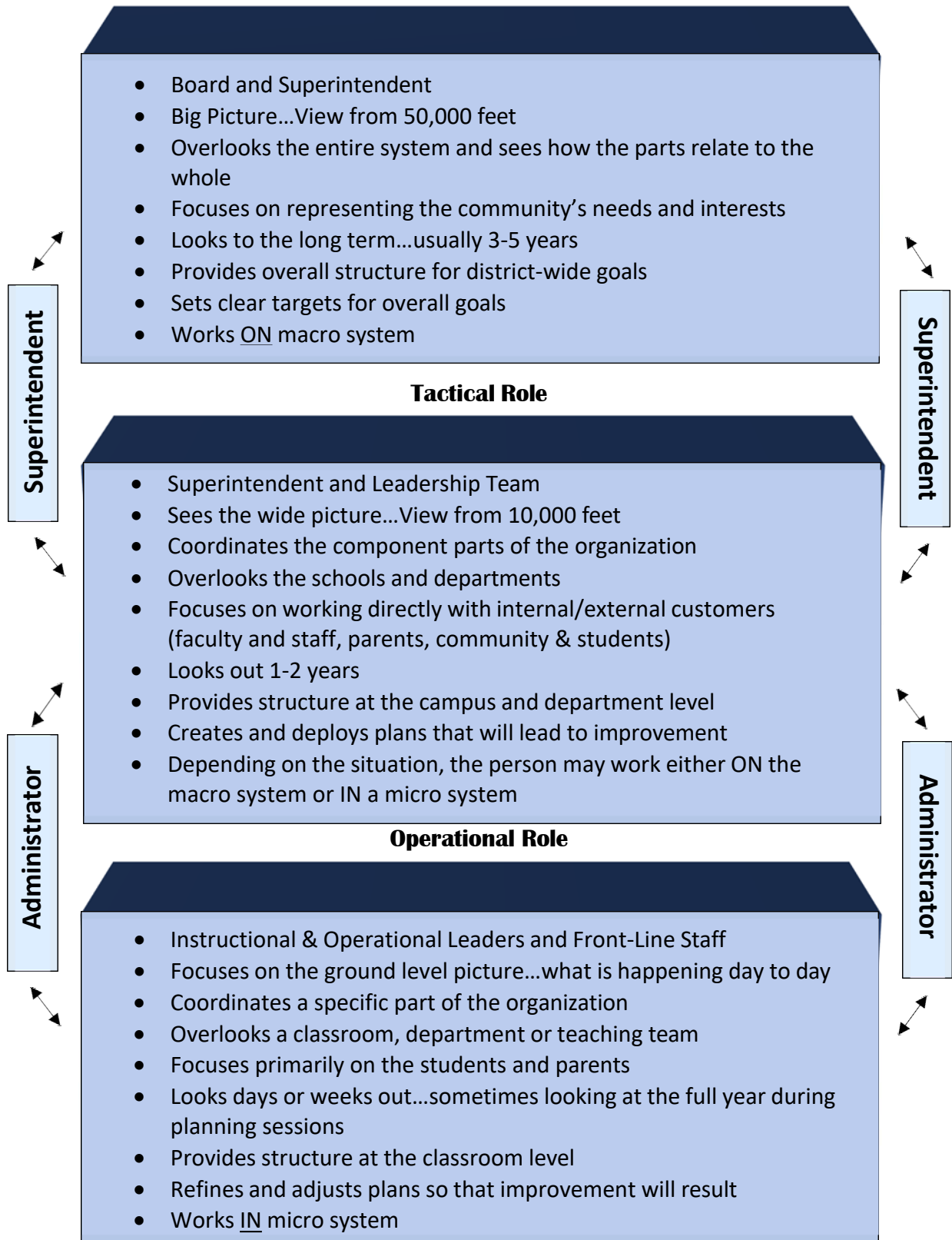

Source: Van Clay, Mark, and Soldwedel, Perry. *The School Board Fieldbook: Leading with Vision*. Solution Tree Press, 2008.
 ©2020 Moak, Casey & Associates - Continuous Improvement Consortium June 17, 2020

At all times, Members will:

1. Request information from or through the Superintendent, and only from staff members with the prior knowledge of the Superintendent.
2. Refer all persons with positive or negative comments regarding school district operations to the proper staff person or administrator directly responsible for the operational activity. Focus on the Board's role and not become involved in the day-to-day operations of the school system. We will not engage in the resolution of problems; rather we will refer these concerns to the Superintendent.
3. The Superintendent encourages Board Member visits to the District, these visits will need to be scheduled with the Superintendent's Office, unless family related.

Before Board Meetings, Members Will:

1. Receive all relevant materials, information, data, etc. related to the agenda items at least 72 hours in advance of regular and special meetings. Board members will direct individual requests for additional materials or information specific to agenda related questions to the Superintendent at least 24 hours prior to the meeting.
2. Request information related to the agenda items from the Superintendent or designee.

During Board Meetings, Members Will:

1. Ensure they are fully prepared, on time and ready to participate.
2. Endeavor to start and end meetings on time.
3. Avoid hidden agendas and springing any surprises on other members.
4. Once recognized by the Board President, ensure that each board member is allowed to speak without interruption.
5. Focus on an agenda item until it is resolved or until a specified time has been reached to resume the resolution process.
6. Say it once, say it well.
7. Model the behaviors the Board expects of students, staff, and community members.
8. Before committing to a position on an agenda item or issue make sure all relevant information has been presented, including the Superintendent's recommendation.

After Board Meetings, Members Will:

1. Support the decisions of the Board and will not work to undermine Board decisions or encourage others to do so.
2. Abide by the confidentiality laws of executive session and ensure all documents, records, reports, etc. are treated in accordance with applicable laws, regulations, policies, etc.
3. Faithfully serve in trust for the entire community.

During Board meetings, Trustees will commit to staying in the Strategic role by focusing on good questioning techniques. The following questions are a sampling of the types of questions that the Medina Valley Trustees are committed to utilizing.

Sample Strategic Questions

1. How does this idea/program fit into our Strategic Plan?
2. What is the vision for this program/idea/concept?
3. How do we quantify progress in this area? How does it trend? How does it compare?
4. How do our stakeholders know this service exists? How would we self-rate our marketing efforts?
5. What percent of the total budget is dedicated to this effort?
6. What is the best way for the Board to help?
7. What else (do we need to know), (do you need in order to be successful), (have we not thought of)?
8. What concerns us most about this?
9. What is worthy of a celebration?
10. Have we aligned the appropriate resources with this initiative?
11. Do our measures appropriately address both progress and cultural impact?
12. Are there budgeted items that are so removed from our strategic direction that they can be strategically abandoned?
13. How does this proposed budgetary expenditure align to our strategic direction and how will it ultimately (positively) impact our community? How much does it cost to sustain? Can we afford it? Does it replace something else or is it an additional expenditure?
14. Is our target set too high? Too low?
15. Is this the best measure for success?
16. Which Perspective does this help? Is there a potential negative unintended impact on another perspective?
17. What does this data seem to tell us? Not tell us?
18. What improvement might arise from this data?
19. Did we miss something in our Strategic Objective when we first defined it?
20. Are we validating with our ears too much (anecdotal) and not with our eyes (data)? And, vice versa...?
21. Are we maintaining our strategic focus or are we off track?
22. What research would we need to undertake in order to “know what we don’t know”?
23. How is this being perceived at the operational level (front-line)? (Besides anecdotal evidence)
24. How do we know this is aligned to our customers’ needs?
25. Are our Strategic Objectives well understood at the operational level? How do we know?
26. Are we innovative enough? What is our tolerance/process for innovation?

Developing the Board Agenda BE (LOCAL)

In consultation with the Board President, the Superintendent shall prepare the agenda for all Board meetings. Any Board member may request that a subject be included on the agenda for a meeting, per MVISD Board Policy BE (LOCAL). The Superintendent shall include on the preliminary agenda of the meeting all topics that have been timely submitted by a Board member.

Before the official agenda is finalized for any meeting, the Superintendent shall consult the Board President to ensure that the agenda and the topics included meet with the Board President's approval. In reviewing the preliminary agenda, the Board President shall ensure that any topics the Board or individual Board members have requested to be addressed are either on that agenda or scheduled for a future agenda. The Board President shall not have authority to remove from the agenda a subject requested by a Board member without that Board member's specific authorization.

If possible the agenda and all supporting materials will be available to Board Members one week prior to the meeting. The latest agenda and supporting materials will be available is 72 hours before the Board Meeting. Any questions or requests for additional information on agenda items should be directed to the Superintendent prior to the Board Meeting. All information requested will be shared with all the members of the Board.

The Board President in collaboration with the Superintendent will maintain a continuous Board Planning Calendar for the year, items may be added or deleted as appropriate.

Board Agenda Format BE (LOCAL)

Regular Board Meetings are scheduled for conducting business on the 4th Monday of each month. Special meetings are scheduled as needed for specific needs that can not wait until the next Regular Board Meeting or agenda items that legally require a separate Special Board Meeting.

The Board meeting agenda may include a period for student/staff recognitions, public comments, announcements/communications/presentations, consent agenda items, discussion and actions items, closed session, and other items as needed per Board President and/or Superintendent.

Public Comments at Board Meetings BED (LOCAL)

The Board of Trustees welcomes and encourages comments from the public. A Public Comment period is held at all Board meetings. Members of the public desiring to participate in the Public Comment period may sign up prior to the start of the board meeting. Each public comment is allowed 5 minutes. When necessary for effective meeting management or to accommodate large numbers of individuals wishing to address the Board, the presiding officer may make adjustments to the public comment procedures; reordering agenda items, deferring public comment on non-agenda items, continuing agenda items to a later meeting, and/or adjusting the time allotted to each speaker, although no individual will be given less than one minute. The individual who is listed to speak must be the individual who actually speaks during the Public Comment period (*i.e.*, another individual may not take the place of someone who has signed up to speak).

At regular board meetings, board members shall hear public comments on all topics. During special board meetings, board members will hear public comments on agenda items only. The Public Comment period is not intended for the presentation of allegations of employee misconduct; requests for employee discipline; lodging personal attacks; shaming; or demeaning specific named MVISD employees; or unnecessarily disclosing private information about MVISD employees or students. If necessary the Board President will refer the individual(s) to the District's formal grievance process which can be found online and includes MVISD Board Policies DGBA, FNG, and GF. The Superintendent or designee may follow up with persons who have commented during Public Comments.

Meeting Procedures and Information BE (LOCAL)

The Texas Open Meetings Act permits the Board to deliberate and act only as a corporate body at a properly called meeting with a quorum of the Board Members.

The Board shall observe *Robert's Rules of Order* parliamentary procedures.

The board may act only by majority vote of the members present at a meeting held in compliance with Government Code Chapter 551 (Open Meetings Act), at which a quorum of the board is present and voting. Unless authorized by the board, a member of the board may not, individually, act on behalf of the board.
Education Code 11.051(a-1).

Communications and Media BBF (LOCAL)

The Superintendent or designee will communicate with all Board members weekly or with increased frequency as needed. Emergency or crisis information will be shared with the Board Members by the Superintendent or designee at the earliest time possible. Information presented to one Board Member will also be shared with all of the remaining Board Members.

Board members will abide by the Board's Code of Ethics in Board Policy BBF(LOCAL) and the expectations for civility and conduct, as stated herein.

Board Members who participate in social media such as, but not limited to, Facebook, Google+, LinkedIn, Instagram, or Twitter should be careful to avoid online conversations that could be construed as speaking for the Board or constituting an online Board meeting. When creating posts or comments the Board Member will be supportive of the district, superintendent and all Board decisions.

The Superintendent shall be the official spokesperson **for the District**. The President or the Board designee shall be the official spokesperson **for the Board**. All Board Members who receive communications from the media shall direct the inquiries as stated above.

Board Member Compliance with Policy and Procedures BBF (LOCAL) & BBC (LEGAL)

Board members shall abide by these Guidelines and MVISD Board Policy. As trustees of the District, Board members are fiduciaries of the District, meaning Board members have an obligation not to act in a manner adverse to the District's interests. In the event that a Board member fails to abide by the Good Governance Handbook and MVISD Board Policy, or fails to properly act as a fiduciary of the District, the following actions may be taken:

- Private conversation between the Board President and the Board member;
- Confidential conversation between the Board member and the Board's attorney;
- Closed session discussion between the Board member and the remainder of the Board;
- Written communication from the Board's attorney to the Board member;
- Appropriate and lawful verbal censure of the Board member; and/or
- Other appropriate and legal actions.

General Information BBE (LOCAL)

Individual Board members may request, through the Superintendent, designee, and/or the Board President, any legally available information or reports concerning the District, students or personnel. Board member requests for information shall be consistent with Policy BBE(LOCAL). The Superintendent or designee shall disseminate the requested information to all Board members. Board members shall take care to avoid any action that may constitute a misuse of official and/or confidential information, as set forth in Texas Penal Code § 39.06 and Texas Government Code § 552.352.

Board members will evaluate the Superintendent during closed session each calendar year. The agenda will reflect the Evaluation of the Superintendent.

Trustee Elections BBA (LOCAL) and BBB (LOCAL)

The Medina Valley ISD Board of Trustees consists of seven members, two elected at-large and five elected from single-member districts, serving terms of three years, with elections held annually. The terms of one-third of the Board members, or as near to one-third as possible, expire each year. [*Education Code 11.051(b), .052, .059*] School Board elections for the District are on the May uniform election date.

- Single Member Districts 1 and 2: The election for single-member district 1 and 2 shall be held in 2024, 2027, 2030 and in three-year intervals thereafter.
- Single Member Districts 3 and 4: The election for single-member district 3 and 4 shall be held in 2025, 2028, 2031 and in three-year intervals thereafter.
- District 5 and the 2 At-Large Positions: The election for single-member district five and the At-Large Positions shall be held in 2026, 2029, 2032 and in three-year intervals thereafter.

Board Officer Nominations and Elections BDAA (LEGAL & LOCAL)

The Board shall elect a President, Vice President, and a Secretary. Board Members become eligible to hold an officer position on the Board after one year of service on the Board. Officers shall be elected by majority vote of the members present and voting.

Board Officers shall serve for a term of one year, or until a successor is elected. Officers may succeed themselves in office. Each officer shall perform any legal duties of the office and other duties, as required by the Board.

The Board will reorganize after each trustee election. The month prior to reorganization Board Members will be sent an email from the Superintendent's Office requesting each Board Member to respond with their interest in holding or not holding a specific or any Board Officer position. The Superintendent's Office will share these responses with all the Board Members. *BDAA Legal, Education Code 11.061(c)*

Removal from consideration: An individual Board Member may, by simple announcement, remove himself or herself from consideration for any or all offices of the Board.

In the event of a vacancy in an Officer's position, the Board may, by majority action of the Board at any duly called meeting, fill the vacancy.

Required Board Member Training BBD (LEGAL & LOCAL)

A trustee must complete any training required by the State Board of Education (SBOE) *Education Code 11.159*. At the last regular board meeting before an election of trustees, the board president shall announce the name of each board member and their continuing education achievements or deficiencies.

Review of Good Governance Guidelines BG (LEGAL)

The Board of Trustees will annually review and update the Board's Good Governance Guidelines. Compliance with these guidelines will be reviewed and discussed by the Board during an annual self-evaluation.

Medina Valley Independent School District

Agenda Item Memorandum

To: MVIDS Board of Trustees

Date: February 26, 2024

RE: Consider Acceptance of Certification of Unopposed Candidate for Single Member District #2

The authority responsible for preparing the ballot must certify the unopposed status to the authority responsible for ordering the election. This document is filed with the presiding officer of the political subdivision. The governing body must meet, accept this certification, and issue an order or ordinance declaring the election cancelled and the unopposed candidates elected. The Unopposed Candidate will be sworn into office at the Election Canvass. Joe Biediger's application for a place on the ballot was the only application received for the Single Member District #2.

Single Member District #1 did not receive any applications. At the Election Canvass Single Member District #1 will be declared vacant. At that time the Board will initiate the process to announce the vacancy, schedule interviews and appoint a Board Member to fill the SMD #1 position until the next Regular Election.

Texas Election Code Section 2.051 – 2.053

**CERTIFICATION OF UNOPPOSED CANDIDATES FOR OTHER
POLITICAL SUBDIVISIONS (NOT COUNTY) CERTIFICACIÓN DE
CANDIDATOS ÚNICOS
PARA OTRAS SUBDIVISIONES POLITICAS (NO EL CONDADO)**

To: Presiding Officer of Governing Body
Al: *Presidente de la entidad gobernante*

As the authority responsible for having the official ballot prepared, I hereby certify that the following candidates are unopposed for election to office for the election scheduled to be held on May 4, 2024.

Como autoridad a cargo de la preparación de la boleta de votación oficial, por la presente certifico que los siguientes candidatos son candidatos únicos para elección para un cargo en la elección que se llevará a cabo el May 4, 2024.

List offices and names of candidates:
Lista de cargos y nombres de los candidatos:

Office(s) *Cargo(s)*

Single Member District #2

Candidate(s) *Candidato(s)*

Joe Biediger

Signature (*Firma*)

Beth Zinsmeyer

Printed name (*Nombre en letra de molde*)

MVSD Board President

Title (*Puesto*)

(Seal) (*sello*)

Date of signing (*Fecha de firma*)

*See reverse side for instructions
(Instrucciones en el reverso)*

Medina Valley Independent School District

Agenda Item Memorandum

To: MVIDS Board of Trustees

Date: February 26, 2024

RE: Consider Adoption of Order to Cancel the May 4, 2024 Trustee Election for Single Member District #1 and Single Member District #2

To Cancel an Election the Board must adopt the Order to Cancel the Election in an Open Meeting. Single Member District #1 did not receive any applications and Single Member District #2 received one application. Both Single Member Districts will not require an election.

Texas Election Code Section 2.051 – 2.053

Medina Valley Independent School District

Order of Cancellation Orden de cancelación

The Medina Valley Independent School District hereby cancels the trustee elections for Single Member District #1, and Single Member District #2 scheduled to be held on May 4, 2024 in accordance with Section 2.052(a) of the Election Code. No candidates filed for Single Member District #1, this position will be declared vacant at the Election Canvass. The following candidate for Single Member District #2 has been certified as unopposed and elected, to be sworn in at the Election Canvass.

El Distrito Escolar Independiente de Medina Valley cancela por la presente las elecciones de fideicomisarios para el Distrito Uninominal #1 y el Distrito Uninominal #2 programadas para el 4 de mayo de 2024 de conformidad con la Sección 2.052(a) del Código Electoral. No se presentaron candidatos para el Distrito Uninominal #1, este puesto será declarado vacante en el Escrutinio Electoral. El siguiente candidato para el Distrito Uninominal #2 ha sido certificado como sin oposición y elegido, para prestar juramento en el escrutinio electoral.

<u>Office Sought (Oficina buscada)</u>	<u>Candidate (Candidato)</u>
Single Member District #2	Joe Biediger

Beth Zinsmeyer
MVISD Board President (Presidenta de la junta)

Jennilea Campbell
MVISD Board Secretary (Secretario de la Junta)

Seal

Date of adoption (Fecha de adopción)

A copy of this order will be posted on Election Day at each polling place that would have been used in the election. (Se publicará una copia de esta orden el día de las elecciones en cada lugar de votación que se hubiera utilizado en las elecciones.)

The Medina Valley Independent School District will proceed with the process to fill the Single Member District #1 vacancy after declaration at the Election Canvass. (El Distrito Escolar Independiente de Medina Valley procederá con el proceso para cubrir la vacante del Distrito Uninominal #1 después de la declaración en el escrutinio electoral.)