

**Medina Valley Independent School District  
Board of Trustees  
Regular Meeting on Monday, September 19, 2022 at 6:30 PM  
Medina Valley ISD Central Office Board Room**

**A Regular Board Meeting of the MVISD Board of Trustees was held on Monday, September 19, 2022, beginning at 6:30 PM at/on Medina Valley ISD Central Office Board Room.**

**I. First Order of Business**

- A Establish a Quorum
- B Pledge of Allegiance to the Flag followed by a moment of silence

**II. Closed Session**

- A Consultation with Attorney (TX Govt. Code Section 551.071) The Board will consult with its legal counsel regarding roles and responsibilities of a public officer and on a matter in which the duty of the attorney to the governmental body under the Texas Disciplinary Rules of Professional Conduct of the State Bar of Texas requires consultation in closed session.
- B Deliberation Regarding Real Property (TX Govt. Code Section 551.072)
- C Personnel Matters (TX Govt. Code Section 551.074) The Board will discuss roles and responsibilities of a public officer and employment
- D Considering the deployment, specific occasions for, or implementation of, security personnel or devices (TX Govt. Code Section 551.076)

**III. Public Comment**

*At Regular Board Meetings the Board shall permit public comment on any topic. At all other Board Meetings public comments will be limited to items on the agenda posted with the notice of the meeting. All Public Comments are limited to 5 minutes.*

**IV. Discussion and Possible Action Items**

- A Consider a limited waiver of the attorney/client privilege to permit counsel to address legal issues requested to be addressed by a trustee, Paula Davidson
- B Discussion regarding legal concerns requested to be addressed by a trustee, Paula Davidson, related to concerns about alleged Open Meeting Act issues and issues related to the consideration of a land purchase

**V. Announcements/Communications/Presentations**

- A HB3 Goals and Support Plans 3  
Natalie Benke
- B Financial Briefing 18  
Juan C. Zamora
- C Superintendent Briefing 22
- D First Reading of TASB Initiated Policy Update 119 34

**VI. Continued Discussion and Possible Action Items**

- A **Consent Agenda Items** **66**
  - 1 Minutes of Regular Board Meeting on August 15th and Special Board Meeting on August 29th, September 2nd, and September 13th 67
  - 2 Donations 76
  - 3 Out of State Travel Request 79
- B Consider Resolutions of Extracurricular Status of 4-H Organizations for Medina County and Bexar County 80  
Dr. Caloss
- C Consider Adjunct Faculty agreements with Medina County and Bexar County 83
- D Annual School Health Advisory Council (SHAC) Report and consideration of Council Membership for 2022-2023 88
- E Consider a Resolution of Self-Certification of Increased Micro-Purchase Threshold 94  
Juan Zamora
- F Consider Purchase and Installation of Compressor for Chiller at LaCoste Elementary 96
- G Consider the Purchase of Three Facility Department Vehicles 98
- H Consider the Purchase of Portables 100
- I Consider the Purchase of New Buses 104
- J Consider Contract for Construction of Tennis Courts at Loma Alta Middle School 150
- K Consider Monthly Budget Amendment 157
- L Consider Professional Contract Recommendations
- M Consideration of Future Meeting Dates

**VII. Adjournment**

(Items do not have to be taken in the same order as shown on the meeting agenda.)

# **MVISD School Board Meeting**

September 19, 2022

**Closed  
Session**

# Medina Valley Independent School District

## *Agenda Item Memorandum*

*To: MVISD Board of Trustees*

*Date: 9-19-2022*

*RE: HB3 Board Goals & Plans*

House Bill 3 requires Texas school boards to develop, adopt and post early childhood literacy and mathematics proficiency goals and support plans. The Board adopted these goals and support plans in 2019. This is the required annual review of these goals and support plans.



HB3 Implementation

Early Childhood

CCMR Board

Adopted Plans and Goals

---

## **House Bill 3: Requires Boards of Trustees to develop and post early childhood literacy and mathematics proficiency plans that set specific annual goals.**

**Under HB 3, school boards are required to adopt plans in early childhood literacy and math, as well as college, career, and military readiness. All plans are required to include:**

- **at least one assigned district-level administrator or employee of the regional education service center for the district's region to coordinate implementation and submit annual report to the board on the district's progress;**
- **an annual review by the board at a public meeting;**
- **an annual report posted on district and campus websites; and**
- **specific, quantifiable, annual goals for five years at each campus.**

---

## **Early childhood plans are required to include:**

- **annual goals for aggregate student growth on 3rd grade math and reading STAAR;**
- **annual targets for students in each group evaluated under closing the gaps domain;**
- **targeted professional development for classroom teachers in kindergarten through 3rd grade for campuses that the board identifies as not meeting the plan's goals and that considers the unique needs of students in bilingual education or special language programs.**
- **annual targets that may be set for students in bilingual or ESL programs.**

---

**College, career, and military readiness plans are required to include:**

- **annual goals for aggregate student growth on CCMR readiness indicators evaluated under the student achievement domain; and**
- **annual targets for students in each group evaluated under closing the gaps domain.**

**How to access: [mvisd.com](http://mvisd.com)**

**[HB3 Board Goals & Plans](#)**

---

# Are we meeting the mark?

**3rd Grade STAAR Reading Performance- Goal of 63% by 2024. For the 2021-2022 school year the district had a goal of 53% meeting Meets or Masters on the 3rd Grade STAAR. As a district we stand at 59.3%, 6.3% above expectations.**

**K students that score on grade level or above in Reading on the (TPRI/mClass) EOY will increase from 44% (BOY- Covid); 87%(EOY) to 96% (EOY) by June 2024. The goal for the 2021-2022 school year was 90%. MVISD students completed the 2021-2022 EOY assessment with 63% meeting or achieving grade level expectations, pacing 19 percent above COVID start point, but 27% behind district goal.**

**The percent of Pre-K students that score on grade level or above in Reading on the AIM will increase from 95% EOY AIM to 100% EOY AIM by June 2024.**

## **EB (Emergent Bilingual)**

**During the 2021-2022 school year, 53% of emergent bilingual 3rd grade students at MVISD achieved Meets or Masters on 3rd grade math. Overall state performance for ALL students was 42%**

---

---

# **MVISD Focusing on Literacy & Learning & Targeted Professional Development**

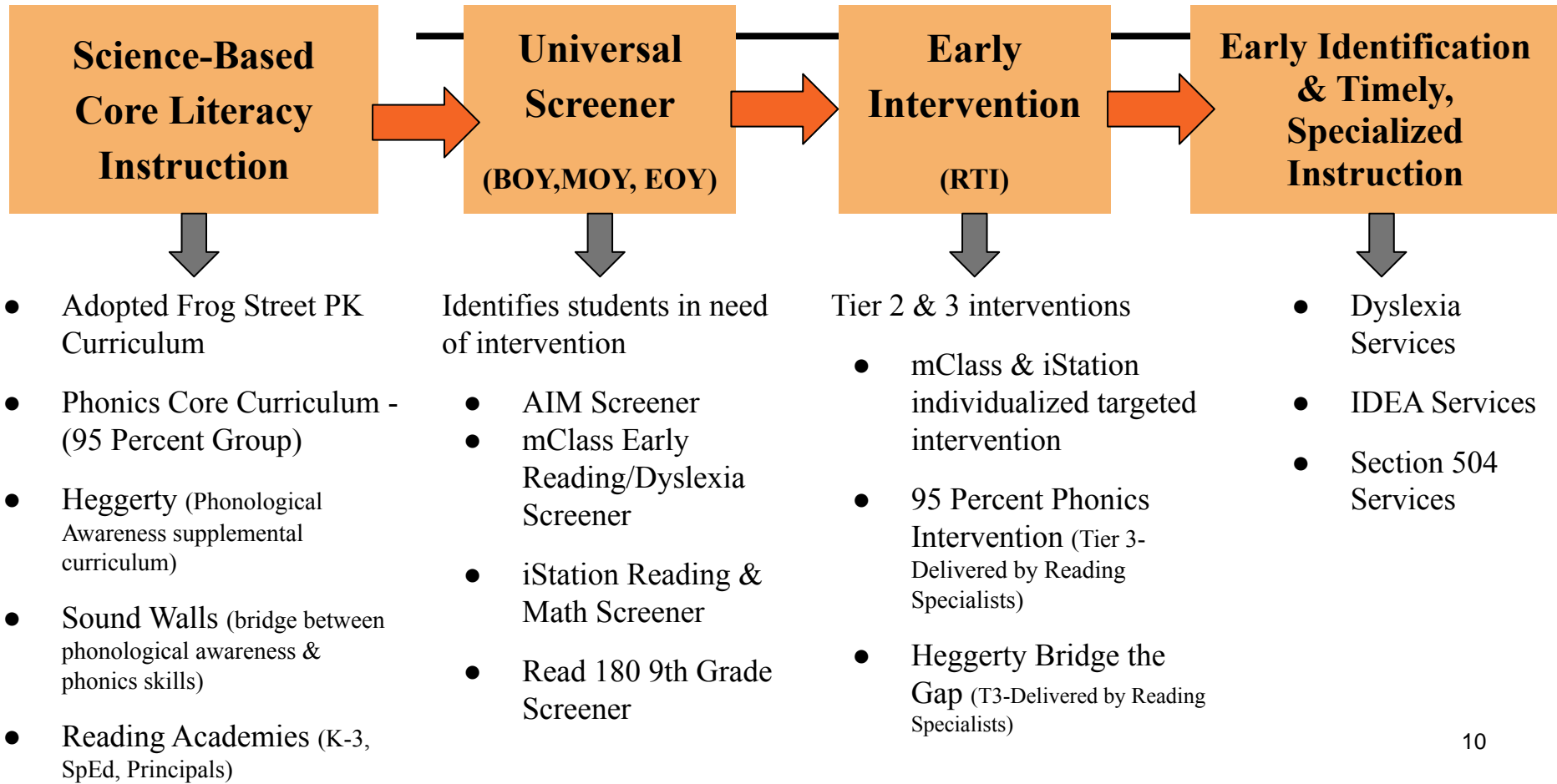

---

# Are we moving the needle?

**The percent of 3rd grade students that score meets grade level or above on STAAR Math will increase from 48% (2019) to 53% by June 2024. The 20-21 Baseline results (post covid) was 38%. The new goal for 2021-2022 was 43%. We are at 46%, reflecting an 8% increase from our baseline.**

**The percent of Kindergarten students that score on grade level or above in math on the ISIP will increase from (86% to 95%) by June 2024. In 2021-2022, 87% of students were at standard. Our goal was 89%.**

**The percent of PreK students that score on grade level or above in math on the (Gold/ AIM) will increase from 73% (MOY) to 85% (EOY) by June 2024. Our target was 79% for 2021-2022, and 70% of MVISD students are meeting standard. Adjustments are being made for the rigor of the new screening tool.**

---

# Are we moving the needle? continued

CCMR - Distinction Earned!! A look at why.....

56% of our students earned Industry Based Certifications. State average was 10%. The board goal was 11% for 2021-2022. This translates to 208 students meeting this target compared to the board goal of 41 students. The MVHS expectation is for this number to grow from 5-7% in 2022-2023.

---

## Relentless Pursuit of Success.....

MVHS will continue to push students to earn Industry Based certifications. With a district set goal of 14%, and student performance currently at 56%, the high school upped their target performance to 63% for the 2022-2023 school year.

To build on success in ELA, the high school will continue to push dual credit, SAT/ACT testing, and a tighter curriculum to drive ELA performance. The same protocol has been implemented in Math, which will correlate to closing the gap in Math.

## MVHS and State College Ready Graduate Comparison

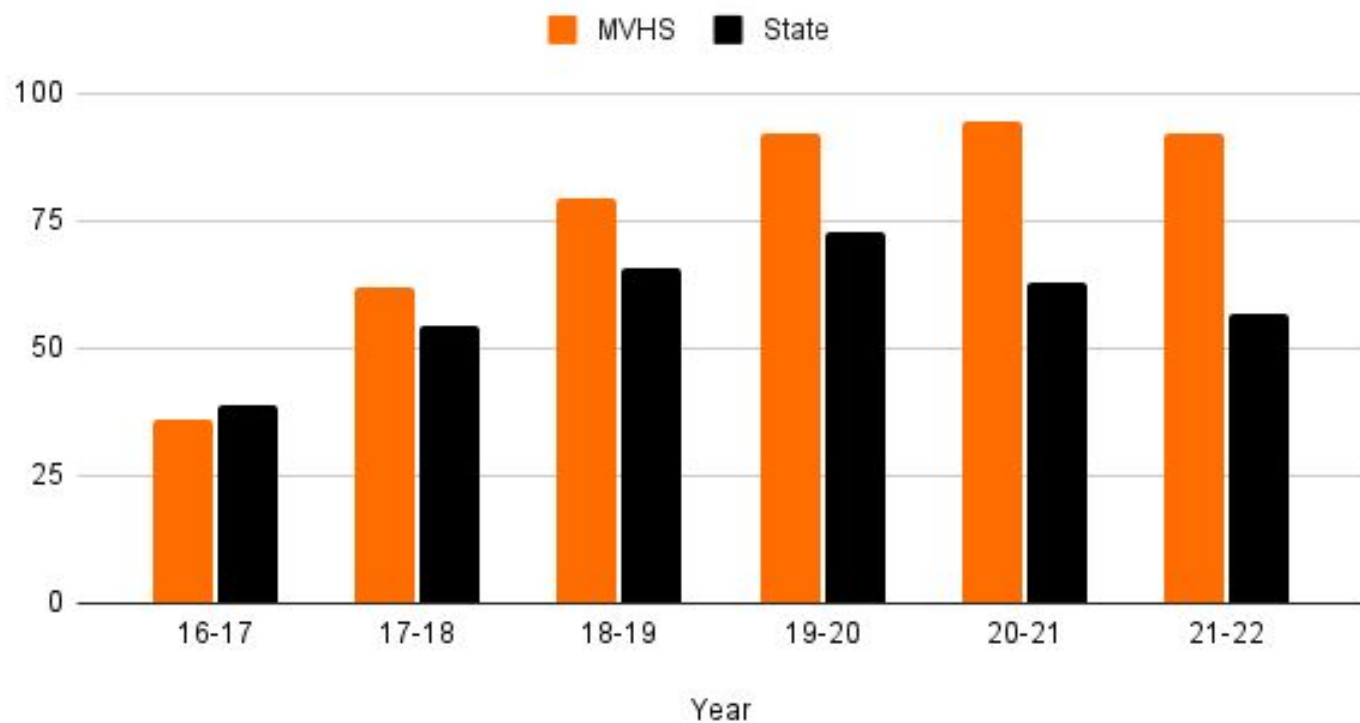

---

---

Questions?

**HB 3 Board Goals and Plans Support**  
**(Tab Guide)**

Tab #1 Early Childhood Literacy Goal

Tab #2 Early Childhood Literacy Progress Measures (PK - 3)

Tab #3 - Tab #5 Early Childhood Literacy Progress Reports

Tab #6 - Tab #10 Early Childhood Literacy Campus Plans

Tab #11 Early Childhood Math Goal

Tab #12 Early Childhood Math Progress Measures

Tab #13 - Tab #15 Early Childhood Math Progress Reports

Tab #16 - Tab #20 Early Childhood Math Campus Plans

Tab #21 CCMR Board Goal

Tab #22 CCMR Progress Measures

Tab #23 Campus Plan

Tab #24 CCMR Progress Report Math

Tab #25 CCMR Progress Report ELA

Tab #26 CCMR Progress Report IBC

## MVISD CCMR Data – Aligning to the MVISD Mission and Vision

MVISD CCMR Data	Students	Percent
<b>2022 College, Career, and Military Readiness</b>		
Total graduates 375	375	
Total credit for CCMR criteria	345	92%
<b>Texas Success Initiative (TSI) Criteria</b>		
Met TSI criteria in both ELA/Reading and Mathematics 190 51%	190	51%
<b>TSI Criteria - ELA/Reading</b>		
Met TSI criteria for at least one indicator in ELA/Reading	215	57%
Met TSI assessment criteria	72	19%
Met ACT criteria	38	10%
Met SAT criteria	18	5%
Earned credit for a college prep course	137	37%
<b>TSI Criteria - Mathematics</b>		
Met TSI criteria for at least one indicator in Mathematics	224	60%
Met TSI assessment criteria	51	14%
Met ACT criteria	39	10%
Met SAT criteria	13	4%
Earned credit for a college prep course	158	42%
<b>AP/IB Examination</b>		
Met criterion score on an AP/IB exam in any subject	29	8%
<b>Dual Course Credits</b>		
Earned credit for at least 3 hours in ELA or Mathematics or 9 hours in any subject	221	59%
<b>Industry-Based Certifications</b>		
Earned an industry-based certification from approved list	208	56%
<b>Level I or Level II Certificate</b>		
Earned a level I or level II certificate in any workforce education area	0	0%
<b>Associate Degree</b>		
Earning an associate degree by August 31 immediately following high school graduation	0	0%
<b>Graduate with Completed IEP and Workforce Readiness</b>		
Received graduation type code of 04, 05, 54, or 55	7	2%
<b>Special Ed with Advanced Diploma Plan</b>		
Received special education services and earned an advanced diploma plan	15	4%
<b>U.S. Armed Forces*</b>		
Enlisted in the U.S. Armed Forces	N/A	N/A

**Medina Valley Independent School District  
Investment Report for the Quarter Ending August 31, 2022**

Depository Type	Type of		%	5/31/22	5/31/22	Changes			8/31/22	8/31/22
	Account Name	Account		Book Value	Market Value	Deposits	Withdrawals	Interest	Book Value	Market Value
Lone Star Investment Pool	General Operating	Overnight Plus	1.79%	\$ 24,378,069	\$ 24,374,850	\$ 20,228,343	\$ (19,880,314)	\$ 110,777	\$ 24,836,875	\$ 24,836,035
Lone Star Investment Pool	Interest & Sinking	Overnight Plus	1.79%	\$ 9,247,109	\$ 9,245,888	\$ 584,615	\$ (4,335,778)	\$ 35,874	\$ 5,531,820	\$ 5,531,633
Lone Star Investment Pool	Capital Projects (Series 2019)	Overnight Plus	1.79%	\$ 4,461,035	\$ 4,460,447	\$ -	\$ (1,409,529)	\$ 16,413	\$ 3,067,919	\$ 3,067,816
Lone Star Investment Pool	Capital Projects (Series 2021)	Overnight Plus	1.79%	\$ 38,123,108	\$ 38,118,076	\$ -	\$ (248,073)	\$ 171,825	\$ 38,046,860	\$ 38,045,575
Lone Star Investment Pool	Capital Projects (Series 2022)	Overnight Plus	1.79%	\$ -	\$ -	\$ 15,000,000	\$ -	\$ 58,626	\$ 15,058,626	\$ 15,058,117
Broadway Bank	General Operating	Public Funds Now	0.00%	\$ 3,149,557	\$ 3,149,557	\$ 21,051,924	\$ (22,691,276)	\$ -	\$ 1,510,205	\$ 1,510,205
Broadway Bank	Payroll	Public Funds Now	0.00%	\$ 629,053	\$ 629,053	\$ 14,816,127	\$ (14,689,920)	\$ -	\$ 755,259	\$ 755,259
Broadway Bank	Workers Compensation	Public Funds Now	0.00%	\$ 903,373	\$ 903,373	\$ 79,242	\$ (56,796)	\$ -	\$ 925,819	\$ 925,819
<b>Total</b>				<b>\$ 80,891,303</b>	<b>\$ 80,881,243</b>	<b>\$ 71,760,251</b>	<b>\$ (63,311,685)</b>	<b>\$ 393,515</b>	<b>\$ 89,733,384</b>	<b>\$ 89,730,459</b>

**AUGUST 2022**  
**MEDINA VALLEY INDEPENDENT SCHOOL DISTRICT**  
**GENERAL FUND FINANCIAL STATEMENT**

<u>Estimated Revenues</u>	<u>Current Budget</u>	<u>Current Period Actual</u>	<u>YTD Actual</u>	<u>Balance</u>	<u>Current Year Percent Recognized</u>
5700 Local Revenues	\$ 27,540,029	\$ 184,420	\$ 27,636,235	\$ (96,206)	100.35%
<b>5800 State Program Revenues</b>	<b>\$ 35,389,347</b>	<b>\$ 9,042,833</b>	<b>\$ 35,599,277</b>	<b>\$ (209,930)</b>	<b>100.59%</b>
5900 Federal Revenues	\$ 1,325,000	\$ 497,704	\$ 1,372,469	\$ (47,469)	103.58%
<b>Total Revenues</b>	<b>\$ 64,254,376</b>	<b>\$ 9,724,957</b>	<b>\$ 64,607,981</b>	<b>\$ (353,605)</b>	<b>100.55%</b>
<b>Proposed Appropriations</b>					
11 Instruction	\$ 36,542,742	\$ 3,210,761	\$ 36,126,579	\$ 416,163	98.86%
<b>12 Media Services</b>	<b>\$ 947,711</b>	<b>\$ 517,839</b>	<b>\$ 936,954</b>	<b>\$ 10,757</b>	<b>98.86%</b>
13 Staff Development	\$ 687,301	\$ 92,530	\$ 673,224	\$ 14,077	97.95%
<b>21 Instruct. Leadership</b>	<b>\$ 829,867</b>	<b>\$ 90,963</b>	<b>\$ 826,390</b>	<b>\$ 3,477</b>	<b>99.58%</b>
23 School Leadership	\$ 3,188,638	\$ 301,820	\$ 3,183,409	\$ 5,229	99.84%
<b>31 Counseling</b>	<b>\$ 2,451,309</b>	<b>\$ 221,816</b>	<b>\$ 2,412,679</b>	<b>\$ 38,630</b>	<b>98.42%</b>
32 Social Work Services	\$ 544,337	\$ 26,536	\$ 519,741	\$ 24,596	95.48%
<b>33 Health Services</b>	<b>\$ 819,758</b>	<b>\$ 76,351</b>	<b>\$ 801,089</b>	<b>\$ 18,669</b>	<b>97.72%</b>
34 Student Transportation	\$ 4,043,221	\$ 193,649	\$ 3,955,265	\$ 87,956	97.82%
<b>35 Food Service</b>	<b>\$ 60,000</b>	<b>\$ 10,460</b>	<b>\$ 50,513</b>	<b>\$ 9,487</b>	<b>84.19%</b>
36 Extracurricular Activities	\$ 1,880,263	\$ 99,985	\$ 1,782,211	\$ 98,052	94.79%
<b>41 General Admin</b>	<b>\$ 2,321,421</b>	<b>\$ 230,056</b>	<b>\$ 2,289,981</b>	<b>\$ 31,440</b>	<b>98.65%</b>
51 Maint. Operations	\$ 7,077,793	\$ 708,858	\$ 6,846,168	\$ 231,625	96.73%
<b>52 Security/Monitoring</b>	<b>\$ 621,689</b>	<b>\$ 33,028</b>	<b>\$ 539,893</b>	<b>\$ 81,796</b>	<b>86.84%</b>
53 Data Processing	\$ 1,742,641	\$ 131,217	\$ 1,735,091	\$ 7,550	99.57%
<b>61 Community Services</b>	<b>\$ 24,686</b>	<b>\$ 1,422</b>	<b>\$ 11,747</b>	<b>\$ 12,939</b>	<b>47.58%</b>
81 Facilities Construction	\$ 5,000	\$ 257	\$ 4,041	\$ 959	0.00%
<b>95 JJAEP</b>	<b>\$ 5,000</b>	<b>\$ -</b>	<b>\$ -</b>	<b>\$ 5,000</b>	<b>0.00%</b>
99 Intergovernmental	\$ 441,000	\$ 25,829	\$ 430,656	\$ 10,344	97.65%
<b>Totals</b>	<b>\$ 64,234,377</b>	<b>\$ 5,973,378</b>	<b>\$ 63,125,630</b>	<b>\$ 1,108,747</b>	<b>98.27%</b>
<b>Current Year Estimated Surplus</b>	<b>\$ 1,482,351</b>				
<b>Beginning Fund Balance</b>	<b>\$ 24,252,521</b>				
<b>Est. Ending Fund Balance</b>	<b>\$ 25,734,872</b>				

**AUGUST 2022**  
**MEDINA VALLEY INDEPENDENT SCHOOL DISTRICT**  
**FOOD SERVICE FUND FINANCIAL STATEMENT**

<u>Estimated Revenues</u>	<u>Current Budget</u>	<u>Current Period Actual</u>	<u>YTD Actual</u>	<u>Balance</u>	<u>Current Year Percent Recognized</u>
5700 Local and Intermediate Revenues	\$ 363,270	\$ 136,769	\$ 502,638	\$ (139,368)	138.36%
<b>5800 State Program Revenues</b>	<b>\$ -</b>	<b>\$ -</b>	<b>\$ 6,698</b>	<b>\$ (6,698)</b>	<b>0.00%</b>
5900 Federal Revenues	\$ 4,647,817	\$ 247,430	\$ 5,015,229	\$ (367,412)	107.91%
<b>Total Revenues</b>	<b>\$ 5,011,087</b>	<b>\$ 384,199</b>	<b>\$ 5,524,565</b>	<b>\$ (513,478)</b>	<b>110.25%</b>
<b><u>Proposed Appropriations</u></b>					
<b>11 Instruction</b>					
12 Instructional Resources and Media Services					
<b>13 Curriculum and Instructional Staff Development</b>					
21 Instructional Leadership					
<b>23 School Leadership</b>					
31 Guidance, Counseling and Evaluation Services					
<b>32 Social Work Services</b>					
33 Health Services					
<b>34 Student Transportation</b>					
35 Food Service	\$ 4,488,351	\$ 366,976	\$ 4,195,152	\$ 293,199	93.47%
<b>36 Extracurricular Activities</b>					
41 General Administration					
<b>51 Facilities Maintenance and Operations</b>					
52 Security and Monitoring Services					
<b>53 Data Processing Services</b>					
61 Community Services					
<b>81 Facilities Acquisition and Construction</b>					
95 Payments to JJAEP					
<b>99 Other Intergovernmental</b>					
Totals	\$ 4,488,351	\$ 366,976	\$ 4,195,152	\$ 293,199	93.47%
<b>Current Year Estimated Surplus</b>	<b>\$ 1,329,413</b>				
<b>Beginning Year Fund Balance</b>	<b>\$ 503,846</b>				
<b>Projected End of Year Fund Balance</b>	<b>\$ 1,833,259</b>				

**AUGUST 2022  
MEDINA VALLEY INDEPENDENT SCHOOL DISTRICT  
INTEREST SINKING FUND FINANCIAL STATEMENT**

<u>Estimated Revenues</u>	<u>Current Budget</u>	<u>Current Period Actual</u>	<u>YTD Actual</u>	<u>Balance</u>	<u>Current Year Percent Recognized</u>
5700 Local and Intermediate Revenues	\$ 14,582,853	\$ 74,771	\$ 14,741,927	\$ (159,074)	101.09%
<b>5800 State Program Revenues</b>	<b>\$ -</b>	<b>\$ -</b>	<b>\$ 264,048</b>	<b>\$ (264,048)</b>	<b>0.00%</b>
5900 Federal Revenues	\$ -	\$ -	\$ -	\$ -	0.00%
<b>Total Revenues</b>	<b>\$ 14,582,853</b>	<b>\$ 74,771</b>	<b>\$ 15,005,975</b>	<b>\$ (423,122)</b>	<b>102.90%</b>
<b><u>Proposed Appropriations</u></b>					
11 Instruction					
<b>12 Instructional Resources and Media Services</b>					
13 Curriculum and Instructional Staff Development					
<b>21 Instructional Leadership</b>					
23 School Leadership					
<b>31 Guidance, Counseling and Evaluation Services</b>					
32 Social Work Services					
<b>33 Health Services</b>					
34 Student Transportation					
<b>35 Food Service</b>					
36 Extracurricular Activities					
<b>41 General Administration</b>					
51 Facilities Maintenance and Operations					
<b>52 Security and Monitoring Services</b>					
53 Data Processing Services					
<b>61 Community Services</b>					
71 Debt Service	\$ 14,382,853	\$ 4,337,838	\$ 13,188,743	\$ 1,194,110	91.70%
<b>81 Facilities Acquisition and Construction</b>					
95 Payments to JJAEP					
<b>99 Other Intergovernmental</b>					
Totals	\$ 14,382,853	\$ 4,337,838	\$ 13,188,743	\$ 1,194,110	91.70%
<b>Current Year Estimated Surplus</b>	<b>\$ 1,817,232</b>				
<b>Beginning Year Fund Balance</b>	<b>\$ 3,730,985</b>				
<b>Projected End of Year Fund Balance</b>	<b>\$ 5,548,217</b>				



**Medina Valley**  
INDEPENDENT SCHOOL DISTRICT

# Superintendent Briefing

September 19, 2022

# Denise Robertson

---

2nd Grade Bilingual Teacher  
LaCoste Elementary



## Employee of the Month - September 2022

# District Highlights

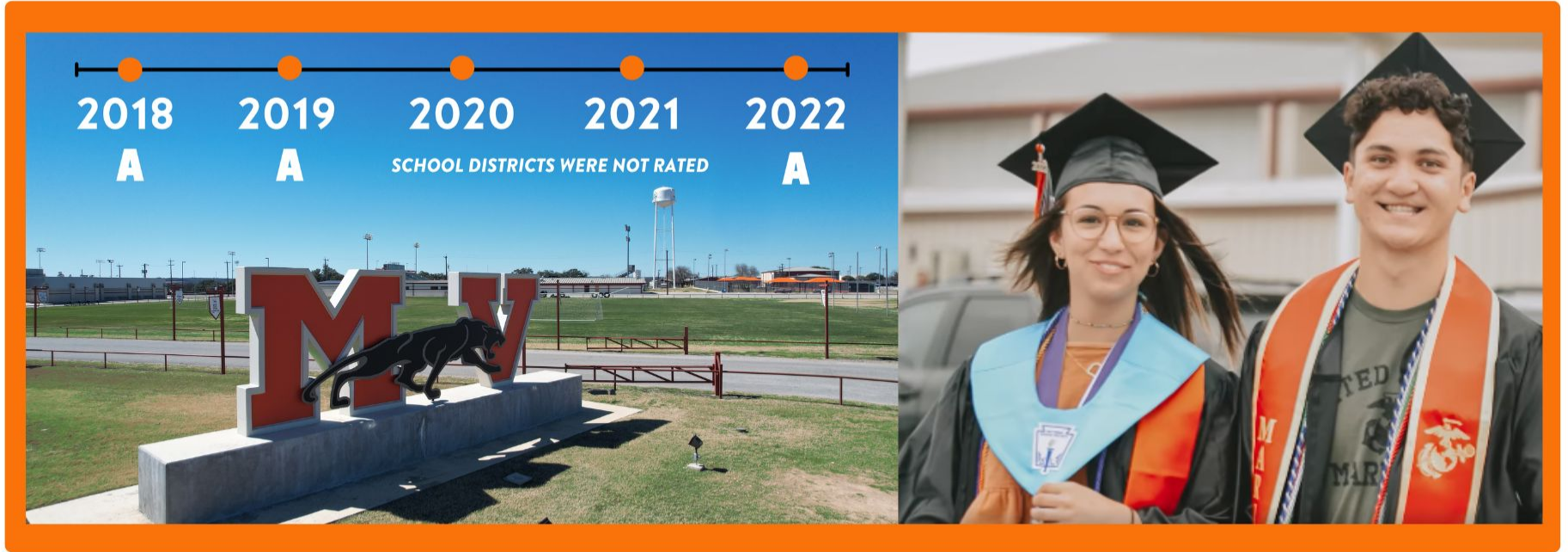

Medina Valley ISD has earned an "A" Rating for 2022 by the Texas Education Agency, with a score of 95 out of 100! We also earned a Postsecondary Readiness Distinction Designation.

- Top Performing District in Region 20 with enrollment of 5,000 or greater (26 Districts)
- Statewide – Of districts with an enrollment of 5,000 students or more, MVISD was the 8th highest performing district statewide out of 199 districts. Only one district with a higher economically disadvantaged population outperformed MVISD.

Region 20 TEA Accountability Scores - 2022

	School District	Rating	Grade	# of Students	
1	Heritage Academy	A	100	572	
2	Basis Texas	A	99	3,421	
3	Falls City ISD	A	97	428	
4	Ingram ISD	A	96	1,172	
5	Medina Valley ISD	A	95	6,727	
6	Randolph Field ISD	A	95	1,458	
7	Knippa ISD	A	95	412	
8	Boerne ISD	A	94	10,268	
9	Poth ISD	A	94	909	25
10	Ft Sam Houston ISD	A	93	1,635	

On Sept. 2 the School Board approved a \$5,000 Bus Driver Incentive Program. Since the Incentive was approved, the District has had 17 new applications.

# Bus Driver Incentive Program

Cross Country, Volleyball,  
Football and Team Tennis  
are all currently in  
season.

**Highlights include:**

- Cross Country
  - Boys Varsity-1st Place  
@ Floresville Meet
  - Girls Varsity- 3rd Place  
@ Floresville Meet
- Team Tennis
  - 4-0 in District





**Twenty-two Medina Valley High School students were recognized for their Academic Achievements on the PSAT and/or AP exam this past school year!**

**Students are able to include this academic honor for national recognition on their college and scholarship applications.**

Elementary Bleacher Creature Nights have begun at our MVHS Football Games. Students from LaCoste and Luckey Ranch Elementary got to run out of the football tunnel and onto the field on Sept. 9

Upcoming Bleacher Creature Nights:

Sept. 23 - Potranco & Ladera  
Oct. 7 - Castroville



**MVISD is adding 3  
new School Resource  
Officers to our team,  
making for a total of 9  
SROs on staff.**



**NAMING FACILITIES**

CW  
(LOCAL)

The responsibility for naming facilities shall rest with the Board.

The Board shall publicly announce its intent to name a new school. The announcement shall provide notice of an opportunity for the community to submit nominations for school names. Nominations shall be submitted on a form provided by the District. Students, staff, and community members may submit nominations.

**Guidelines**

The following guidelines shall be used when naming school facilities:

**Naming Elementary Campuses**

Consideration shall be given to naming elementary schools after the area, road, or subdivision in which they are located. Elementary schools shall not be named for individuals.

**Naming Middle and High School Campuses**

Consideration shall be given to naming middle and high schools to reflect the local heritage, or historical significance, of the school site. All middle and high school names shall begin with "Medina Valley." Middle schools and high schools shall not be named for individuals.

**Naming Specific Buildings or Facilities on a Campus**

Classroom buildings that are part of a campus shall not be assigned separate names.

Requests to name specific facilities on a campus (e.g., libraries, band halls, courtyards, amphitheaters, athletic facilities, and the like) shall be considered on a case-by-case basis. Names previously assigned to such facilities shall remain in use.

**Committee Membership**

The Superintendent may form a committee composed of Board members, administrators, staff, and community members to review proposed names and forward a recommendation to the Superintendent.

**Public Dedication**

A new school building or major addition to a facility shall be dedicated in a public formal ceremony. There shall be a program or open house to which the Board, students, parents, staff, and community members are invited. All plans for the public formal opening of a school shall be made in cooperation with the principal.

**Dedication Plaque**

A dedication plaque shall include the following information:

1. The name of the facility;
2. The year it was completed;
3. The names of the members of the Board at the time the contract for the facility was awarded and at the time of dedication of the facility;

**NAMING FACILITIES**

CW  
(LOCAL)

The responsibility for naming facilities shall rest with the Board.

The Board shall publicly announce its intent to name a new school. The announcement shall provide notice of an opportunity for the community to submit nominations for school names. Nominations shall be submitted on a form provided by the District. Students, staff, and community members may submit nominations.

**Guidelines**

The following guidelines shall be used when naming school facilities:

**Naming Elementary Campuses**

Consideration shall be given to naming elementary schools after the area, road, or subdivision in which they are located. Elementary schools shall not be named for individuals.

**Naming Middle and High School Campuses**

Consideration shall be given to naming middle and high schools to reflect the local heritage, or historical significance, of the school site. All middle and high school names shall begin with "Medina Valley." Middle schools and high schools shall not be named for individuals.

# "Proposed Name for Facility"

Form can be found on our District Website under the News & Announcements Section, as well as on our School Board web page.

## SUBMIT TO:

requests@mvisd.org

## DEADLINE:

October 5, 2022 at 5:00 p.m.

Medina Valley ISD  
163908

NAMING FACILITIES

CW  
(EXHIBIT)

### PROPOSED NAME FOR FACILITY

This form will be used by persons nominating names for new or existing facilities according to CW(LOCAL). Please submit the completed form to the District by established deadlines.

Remember to review CW(LOCAL) for specific guidelines for naming an elementary campus, a middle school campus, and a high school campus.

The responsibility for naming facilities rests with the Board.

**Note:** Classroom buildings that are part of a campus will not be assigned separate names. Requests to name specific facilities on a campus (e.g., libraries, band halls, courtyards, amphitheaters, athletic facilities, and the like) will be considered on a case-by-case basis. Names previously assigned to such facilities will remain in use.

I, \_\_\_\_\_ (print name),

propose that the \_\_\_\_\_ (designation of building and/or location) be named \_\_\_\_\_.

Please state the reason or rationale for your proposed name.

---

---

---

---

---

---

---

---

---

---

Signature: \_\_\_\_\_ Date: \_\_\_\_\_

DATE ISSUED: 5/24/2017  
LDU 2017.04  
CW(EXHIBIT)-X

1 of 1

# District Enrollment

	5/27/22	09/15/22
Castroville Elementary	616	629
LaCoste Elementary	660	718
Ladera Elementary	659	740
Luckey Ranch Elementary	750	853
Potranco Elementary	783	835
Medina Valley Middle School	916	1,018
Loma Alta Middle School	760	801
Medina Valley High School	1,921	2,145
<b>District-Wide</b>	<b>7,065</b>	<b>7,739</b>

## Total Enrollment

May 27, 2022: 7,065  
September 15, 2022: 7,739

# Medina Valley Independent School District

## *Agenda Item Memorandum*

*To: MVISD Board of Trustees*

*Date: 9-19-2022*

*RE: UPDATE 119*

The Texas Association of School Boards (Board Policy Division) periodically recommends revisions to Legal and Local Policy. The Legal policy revisions are changes in Law, which are not subject to Board approval. The TASB recommended Local policy revisions are presented for the Board's consideration. This is the First Reading of Policy Update 119. Update 119 will be presented for consideration at the Regular October Board Meeting.

## (LEGAL) vs. (LOCAL) Policies: Remember the Difference

### **(LEGAL) policies:**

- Reflect the ever-changing legal context for governance and management of the district
- Should inform local decision making
- Should NOT be adopted, but only reviewed

### **(LOCAL) policies:**

- Require close attention by both the administration and the board
- Must reflect the practices of the district and the intentions of the board
- May only be changed by board action (adopt, revise, or repeal)

# Explanatory Notes

## TASB Policy Reference Manual Update 119

### Policy Reference Manual

#### **ATTN(NOTE) GENERAL INFORMATION ABOUT THIS UPDATE**

**Please note:** Unless otherwise noted, references to legislative bills throughout these explanatory notes refer to Senate Bills (SB) or House Bills (HB) from the 87th Legislature Regular and Special Sessions.

#### **AIB(LLEGAL) ACCOUNTABILITY: PERFORMANCE REPORTING**

Quality of learning indicators for remote instruction performance reporting have been added from SB 15 (Second Called Session). (See page 6.)

#### **BBBA(LLEGAL) ELECTIONS: CONDUCTING ELECTIONS**

Upon the board's receipt of certification that a candidate is unopposed in an election, SB 1 (Second Called Session) requires the board to cancel the election and declare each unopposed candidate elected to office.

SB 1 also changed the definition for *eligible county polling place*. Other revisions are to better match legal sources.

#### **BBE(LLEGAL) BOARD MEMBERS: AUTHORITY**

Provisions on board authority that are addressed at other codes have been removed to eliminate duplication.

#### **BBG(LLEGAL) BOARD MEMBERS: COMPENSATION AND EXPENSES**

A revision clarifies that an officer *or employee* may participate in the comptroller's contract for travel services when traveling for official business. The comptroller can no longer charge fees for these services.

#### **BBI(LLEGAL) BOARD MEMBERS: TECHNOLOGY RESOURCES AND ELECTRONIC COMMUNICATIONS**

Revisions are to update citations and better reflect legal sources.

#### **BDAA(LLEGAL) OFFICERS AND OFFICIALS: DUTIES AND REQUIREMENTS OF BOARD OFFICERS**

Revisions are to better reflect legal sources.

#### **BDB(LLEGAL) BOARD INTERNAL ORGANIZATION: INTERNAL COMMITTEES**

Provisions on board committees have been revised based on current legal authority.

#### **BE(LLEGAL) BOARD MEETINGS**

This legally referenced policy on board meetings has been revised to reorder and add some existing legal provisions, delete nonessential provisions, and better reflect legal sources.

#### **BQ(LLEGAL) PLANNING AND DECISION-MAKING PROCESS**

Revised Administrative Code rules resulted in changes to shared services arrangements for DAEP services.

#### **CCGA(LLEGAL) AD VALOREM TAXES: EXEMPTIONS AND PAYMENTS**

As provided by SB 611 (Regular Session) and Senate Joint Resolution 35 and approved by voters in November 2021, the surviving spouse of a member of the U.S. armed forces who is fatally injured in the line

# Explanatory Notes

## TASB Policy Reference Manual Update 119

### Policy Reference Manual

of duty is entitled to the residence homestead property tax exemption as long as the surviving spouse remains unmarried. (See page 5.)

#### **CDB(LLEGAL)                      OTHER REVENUES: SALE, LEASE, OR EXCHANGE OF SCHOOL-OWNED PROPERTY**

Revisions are to better reflect statutory sources.

#### **CDC(LLEGAL)                      OTHER REVENUES: GIFTS AND SOLICITATIONS**

SB 3 (Second Called Session) revised the provisions on prohibited use of private funding for certain curriculum and professional development purposes.

#### **CH(LLEGAL)                      PURCHASING AND ACQUISITION**

We have added a reference on page 12 to amended rules from the Texas Department of Information Resources on purchasing information technology commodity items.

#### **CI(LLEGAL)                      SCHOOL PROPERTIES DISPOSAL**

Revisions are to better reflect statutory sources.

#### **CPC(LLEGAL)                      OFFICE MANAGEMENT: RECORDS MANAGEMENT**

Revisions to this legally referenced policy are based on revised Administrative Code rules from the Texas State Library and Archives Commission (TSLAC) published in [Bulletin B: Electronic Records Standards and Procedures](#). An [overview of Bulletin B](#) is available on the TSLAC website.

#### **CQA(LLEGAL)                      TECHNOLOGY RESOURCES: DISTRICT, CAMPUS, AND CLASSROOM WEBSITES**

Based on HB 1525 (Regular Session) and SB 9 (Second Called Session), we have added the requirement to post curriculum materials on human sexuality instruction and instruction related to the prevention of child abuse, family violence, dating violence, and sex trafficking to the extent the materials are in the public domain. (See item 42.)

#### **CRD(LLEGAL)                      INSURANCE AND ANNUITIES MANAGEMENT: HEALTH AND LIFE INSURANCE**

Revisions to TRS-ActiveCare provisions are based on amended Administrative Code rules. New text addresses prohibitions on offering alternative group health coverage (see page 2) and highlights the information that must be submitted with written elections to participate in TRS-ActiveCare (see page 3).

#### **CS(LLEGAL)                      FACILITY STANDARDS**

Changes throughout this legally referenced policy on facility standards are from new Administrative Code rules that add extensive standards for capital improvement projects on or after November 1, 2021, and revised Administrative Code rules on the standards applicable to these projects before November 1, 2021.

#### **CV(LLEGAL)                      FACILITIES CONSTRUCTION**

Changes to this legally referenced policy on facilities construction are from new Administrative Code rules that add extensive facility standards for construction of capital improvement projects on or after November 1, 2021.

An existing provision has been added on page 3 regarding the board's notice of delegation.

# Explanatory Notes

## TASB Policy Reference Manual Update 119

### Policy Reference Manual

#### **DC(LEGAL) EMPLOYMENT PRACTICES**

We have added on page 4 new Administrative Code rules addressing the monthly certified statement of employment the district must submit to TRS for retirees employed by the district.

#### **DEAA(LEGAL) COMPENSATION PLAN: INCENTIVES AND STIPENDS**

Changes reflect revised Administrative Code rules on the local optional teacher designation system and mentor teacher programs.

#### **DECB(LEGAL) LEAVES AND ABSENCES: MILITARY LEAVE**

This legally referenced policy on military leave has been updated based on revisions to the Uniformed Services Employment and Reemployment Rights Act (USERRA).

#### **DFE(LEGAL) TERMINATION OF EMPLOYMENT: RESIGNATION**

Provisions on contract abandonment are revised based on amended rules from the State Board for Educator Certification. The reasons an educator may abandon a contract for good cause now include the educator's reasonable belief that the educator had written permission from the district to resign. Several new mitigating factors have also been added.

#### **DG(LEGAL) EMPLOYEE RIGHTS AND PRIVILEGES**

SB 3 (Second Called Session) broadened a provision from HB 3979 (Regular Session) so that a teacher may not be compelled to discuss a widely debated and controversial issue of public policy or social affairs for any course or subject. The provision is no longer limited to social studies courses in the required curriculum. (See page 5.)

#### **DHC(LEGAL) EMPLOYEE STANDARDS OF CONDUCT: REPORTS TO TEXAS EDUCATION AGENCY**

Amended Administrative Code rules revise terminology from *solicitation of sexual conduct* to *solicitation of sexual contact* to better align with statute.

#### **DMA(LEGAL) PROFESSIONAL DEVELOPMENT: REQUIRED STAFF DEVELOPMENT**

Revisions are to update citations and better reflect statutory wording.

#### **DP(LEGAL) PERSONNEL POSITIONS**

Provisions on school psychological services have been updated based on revised Administrative Code rules.

#### **E(LEGAL) INSTRUCTION**

The E section table of contents has been updated to add the new code EHDF, which includes provisions on local remote learning programs, and to update the subtitle for EFB, Library Materials.

#### **EF(LEGAL) INSTRUCTIONAL RESOURCES**

SB 3 (Second Called Session) requires a district to provide login credentials to parents to access learning management or online learning portals used for student instructional materials.

# Explanatory Notes

## TASB Policy Reference Manual Update 119

### Policy Reference Manual

#### **EHAA(LEGAL)                      BASIC INSTRUCTIONAL PROGRAM: REQUIRED INSTRUCTION (ALL LEVELS)**

Effective with the 2022–23 school year, SB 9 (Second Called Session) provides that the SHAC must recommend the appropriate grade levels and curriculum for instruction on child abuse, family violence, dating violence, and sex trafficking.

The bill also imposes several requirements regarding curriculum materials on those topics, including:

- Revised parental notification and new parental consent provisions;
- Posting of proposed and adopted curriculum materials and options for a parent to purchase copyrighted materials from the publisher; and
- New board policy on adopting curriculum materials.

The [Regulations Resource Manual](#) includes a sample board resolution for convening the SHAC and a sample parental consent form.

#### **EHBAA(LEGAL)                      SPECIAL EDUCATION: IDENTIFICATION, EVALUATION, AND ELIGIBILITY**

Amended Administrative Code rules now refer to a student with an *auditory impairment* as a student who is *deaf or hard of hearing* to match statute. (See page 5.)

#### **EHBAB(LEGAL)                      SPECIAL EDUCATION: ARD COMMITTEE AND INDIVIDUALIZED EDUCATION PROGRAM**

Amended Administrative Code rules revise the list of individuals who must be included in ARD committee meetings for students with deaf-blindness and revise terminology addressing students who are deaf or hard of hearing. Participating special education teachers or providers must be appropriately certified or licensed as required by federal law. The rules also address, as reflected on page 5, IEP implementation for students who enroll in a new district during the summer.

A new Administrative Code rule prohibits consideration of eligibility for supplemental special education services when developing or revising a student's IEP, determining the appropriate educational setting, or in the provision of a free appropriate public education. (See page 8.)

#### **EHBAC(LEGAL)                      SPECIAL EDUCATION: STUDENTS IN NONDISTRICT PLACEMENT**

We have removed a repealed Administrative Code provision on out-of-state placement.

#### **EHBC(LEGAL)                      SPECIAL PROGRAMS: COMPENSATORY/ACCELERATED SERVICES**

Reporting provisions on expenditure of the state compensatory education allotment have been added from the Administrative Code.

#### **EHDE(LEGAL)                      ALTERNATIVE METHODS FOR EARNING CREDIT: DISTANCE LEARNING**

A new provision from SB 15 (Second Called Session) explains how off-campus electronic courses or programs are counted for purposes of average daily attendance. (See page 12.)

#### **EHDF(LEGAL)                      ALTERNATIVE METHODS FOR EARNING CREDIT: LOCAL REMOTE LEARNING PROGRAM**

Provisions on local remote learning programs from SB 15 (Second Called Session) are reflected in this new legally referenced policy. All provisions in the bill expire on September 1, 2023.

# Explanatory Notes

## TASB Policy Reference Manual Update 119

### Policy Reference Manual

#### **EIF(LLEGAL)                      ACADEMIC ACHIEVEMENT: GRADUATION**

Revised Administrative Code rules provide additional detail on the requirement for a student to complete a financial aid application to meet graduation requirements. The rules, beginning on page 3 of this policy, require the board to adopt the TEA-provided form a student may submit to opt out of the financial aid application requirement and require adoption of a board policy to address the methods by which a student can confirm submission of a financial aid application.

#### **EKB(LLEGAL)                      TESTING PROGRAMS: STATE ASSESSMENT**

HB 3261 (Regular Session) allows a district to administer a state assessment instrument on the first instructional day of the week upon authorization by the commissioner of education.

#### **EMB(LLEGAL)                      MISCELLANEOUS INSTRUCTIONAL POLICIES: TEACHING ABOUT CONTROVERSIAL ISSUES**

SB 3 (Second Called Session) revised provisions on instructional requirements and prohibitions, including prohibited concepts and activities.

#### **FEC(LLEGAL)                      ATTENDANCE: ATTENDANCE FOR CREDIT**

From SB 15 (Second Called Session) we have added a provision permitting a district to exempt students from the 90 percent attendance requirement for courses that are offered under a local remote learning program.

#### **FFG(LLEGAL)                      STUDENT WELFARE: CHILD ABUSE AND NEGLECT**

Revisions are to update citations and better reflect legal sources.

#### **FFH(LLEGAL)                      STUDENT WELFARE: FREEDOM FROM DISCRIMINATION, HARASSMENT, AND RETALIATION**

From SB 9 (Second Called Session) we have added the following on page 2:

- New policy requirements on dating violence, including parental notification upon a report of dating violence; and
- A provision requiring districts to make available to students age-appropriate materials on the dangers of dating violence and resources for students seeking help.

Other revisions are to better reflect legal sources.

#### **FM(LLEGAL)                      STUDENT ACTIVITIES**

Provisions from HB 25 (Third Called Session) address transgender students in athletic activities sponsored or authorized by a district and prohibit a student from participating in an athletic competition that is designated for a biological sex that differs from the biological sex stated on the student's official birth certificate. (See page 8.)

#### **FNA(LLEGAL)                      STUDENT RIGHTS AND RESPONSIBILITIES: STUDENT EXPRESSION**

We have added the recent U.S. Supreme Court case on student speech, *Mahanoy Area School District v B.L.* The case holds that public schools may have a special interest in regulating some off-campus student speech where the district's interest is sufficient to overcome the student's interest in free expression, such as in situations of serious or severe bullying or harassment, threats, or breaches of school security devices.

Explanatory Notes  
TASB Policy Reference Manual Update 119

**Policy Reference Manual**

**FOC(LLEGAL)                      STUDENT DISCIPLINE: PLACEMENT IN A DISCIPLINARY  
ALTERNATIVE EDUCATION SETTING**

Revisions are to better reflect legal sources.

**FOCA(LLEGAL)                      PLACEMENT IN A DISCIPLINARY ALTERNATIVE EDUCATION  
SETTING: DISCIPLINARY ALTERNATIVE EDUCATION PROGRAM  
OPERATIONS**

Amended Administrative Code rules resulted in revisions to shared services arrangements for DAEP services and to provisions regarding transitions for students in DAEP.

**FOF(LLEGAL)                      STUDENT DISCIPLINE: STUDENTS WITH DISABILITIES**

From HB 785 (Regular Session) we have added a provision requiring the commissioner of education to adopt rules regarding the use of restraint and time-out with a student who is receiving special education services. (See page 8.)

**GKA(LLEGAL)                      COMMUNITY RELATIONS: CONDUCT ON SCHOOL PREMISES**

An existing statutory provision has been added to clarify the effect of failing to post signs at each entrance to the premises or other property indicating that firearms and other weapons are prohibited. (See page 8.)

**GKD(LLEGAL)                      COMMUNITY RELATIONS: NONSCHOOL USE OF SCHOOL FACILITIES**

We have added existing statutory provisions regarding the use of district facilities by places of worship.

**GKG(LLEGAL)                      COMMUNITY RELATIONS: SCHOOL VOLUNTEER PROGRAM**

We have updated for clarification the provisions on obtaining criminal history record information.



## (LOCAL) Policy Comparisons

These documents are generated by an automated process that compares the updated policy to the current policy as found in TASB records.

In this packet, you will find:

- Policies being recommended for revision (annotated)
- New policies (not annotated)
- Policies recommended for deletion (annotated in PDF; not shown in Word)

Annotations are shown as follows:

- Deletions are in a red strike-through font: ~~deleted text~~.
- Additions are in a blue, bold font: **new text**.
- Blocks of text that were moved without changes are shown in green, with double underline and double strike-through formatting to distinguish the text's new placement from its original location: ~~moved text~~ becomes moved text.
- Revision bars appear in the right margin to show sections with changes.

---

**Note:** While the annotation software competently identifies simple changes, large or complicated changes—as in an extensive rewrite—may be more difficult to follow. In addition, TASB's recent changes to the policy templates to facilitate accessibility sometimes makes formatting changes appear tracked, even though the text remains the same.

---

For further assistance in understanding policy changes, please refer to the explanatory notes in your Localized Policy Manual update packet or contact your policy consultant.

<b>Contact:</b>	<b>School Districts and Education Service Centers</b>	<b>Community Colleges</b>
	<a href="mailto:policy.service@tasb.org">policy.service@tasb.org</a>	<a href="mailto:colleges@tasb.org">colleges@tasb.org</a>
	800.580.7529 512.467.0222	800.580.1488 512.467.3689

The Superintendent shall oversee the performance of records management functions prescribed by state and federal law:

- Records ~~administrator~~ **Administrator**, as prescribed by Local Government Code 176.001 and 176.~~0065.007~~ [See BBFA and CHE]
- Officer for ~~public information~~ **Public Information**, as prescribed by Government Code 552.201–.205. [See GBAA]
- Public ~~information coordinator~~ **Information Coordinator**, as prescribed by Government Code 552.012. [See BBD]

**Local Government Records Act**

The term “local government record” shall pertain to all items identified as such by the Local Government Records Act.

“Local Government Record”

Records Management Officer

The ~~Superintendent~~ **Superintendent** shall serve as and perform the duties of the District’s records management officer as prescribed by Local Government Code 203.023, and shall administer the District’s records management program pertaining to local government records in compliance with the Local Government Records Act.

*Notification*

The records management officer shall file his or her name with the Texas State Library and Archives Commission (TSLAC) within 30 days of assuming the position.

**Electronic Records**

The records management officer shall develop procedures for the management of electronic records that comply with the District’s records control schedules and meet the minimum components required by law.

The procedures shall:

1. Specify the objectives of the electronic records management program;
2. Identify the responsibilities of employees who create, receive, or maintain electronic records;
3. Ensure the maintenance of electronic records until the expiration of the applicable retention period and final disposition; and
4. Ensure that electronic records that must be protected from unauthorized use or disclosure are appropriately protected as required by law, regulation, or other applicable requirements.

Records Control Schedules

The records management officer shall file with the TSLAC a written declaration that the District has adopted records control schedules

that comply with records retention schedules issued by the TSLAC as provided by law.

**Website Postings**

The District's records management program shall address the length of time records will be posted on the District's website when the law does not specify a posting period.

**Records Destruction Practices**

All local government records shall be considered District property and any unauthorized destruction or removal shall be prohibited. The District shall follow its records control schedules, records management program, and all applicable laws regarding records destruction. However, the District shall preserve records, including electronically stored information, and suspend routine record destruction practices where appropriate and in accordance with procedures developed by the records management officer. Such procedures shall describe the circumstances under which local government records scheduled for destruction must be retained. Notification shall be given to appropriate staff when routine record destruction practices must be suspended and when they may be resumed.

**Training**

The records management officer shall receive appropriate training regarding the Local Government Records Act and shall ensure that custodians of records, as defined by law, and other applicable District staff are trained on the District's records management program, including this policy and corresponding procedures.

PROFESSIONAL DEVELOPMENT  
REQUIRED STAFF DEVELOPMENT

DMA  
(LOCAL)

**The Superintendent shall recommend Staff Development Equivalency**

~~With the District's Superintendent's or principal's prior approval, professional and paraprofessional personnel may attend conventions, conferences, workshops, and seminars on weekends, holidays, summer vacation, or other noninstructional time and be credited with staff development plan for all District employees. The Board shall annually review the professional hours.~~

~~Employees who wish to be excused from a scheduled staff development clearinghouse published by activity shall submit a request to the principal and present evidence of attendance and participation in approved activities not less than two days before the State Board for Educator Certification (SBEC) and annually approve the District's professional scheduled staff development plan. The District's professional development plan must:~~

1. Be guided by the SBEC clearinghouse training recommendations;
2. Note any differences in the District's plan from the clearinghouse recommendations; and

~~Include a schedule of the required professional development for all District employees. activity.~~

**Human Sexuality  
Instruction**

The following process shall apply regarding the adoption of curriculum materials for the ~~District's~~ district's human sexuality instruction:

1. The Board shall adopt a resolution convening the District's school health advisory council (SHAC) to recommend curriculum materials for the instruction.
2. The SHAC shall hold at least two public meetings on the curriculum materials before adopting recommendations to present to the Board.
3. The SHAC recommendations must comply with the instructional content requirements in law, be suitable for the subject and grade level for which the materials are intended, and be reviewed by academic experts in the subject and grade level for which the materials are intended.
4. The SHAC shall present its recommendations to the Board at a public meeting.
5. After the Board ensures the recommendations from the SHAC meet the standards in law, the Board shall take action on the recommendations by a record vote at a public meeting.

**Instruction on  
Prevention of Child  
Abuse, Family  
Violence, Dating  
Violence, and Sex  
Trafficking**

The following process shall apply regarding the adoption of curriculum materials for the District's instruction relating to the prevention of child abuse, family violence, dating violence, and sex trafficking:

1. The Board shall adopt a resolution convening the District's SHAC to recommend curriculum materials for the instruction.
2. The SHAC shall hold at least two public meetings on the curriculum materials before adopting recommendations to present to the Board.
3. The SHAC recommendations must comply with the instructional content requirements in law, be suitable for the subject and grade level for which the materials are intended, and be reviewed by academic experts in the subject and grade level for which the materials are intended.
4. The SHAC shall present its recommendations to the Board at a public meeting.
5. After the Board ensures the recommendations from the SHAC meet the standards in law, the Board shall take action on the recommendations by a record vote at a public meeting.

In accordance with administrative procedures, the District shall provide regular training opportunities for teachers of students with dyslexia that include new research and practices for educating students with dyslexia.

When a student transitions from early childhood intervention (ECI) to early childhood special education (ECSE) services, the District shall develop and implement an individualized education program (IEP) by the child's third birthday.

<b>Referral</b>	Students may be referred for the gifted and talented program at any time by teachers, school counselors, parents, or other interested persons.
Screening and Identification Process	<p>The District shall provide assessment opportunities to complete the screening and identification process for referred students at least once per school year.</p> <p>The District shall schedule a gifted and talented program awareness session for parents that provides an overview of the assessment procedures and services for the program prior to beginning the screening and identification process.</p>
Parental Consent	The District shall obtain written parental consent before any special testing or individual assessment is conducted as part of the screening and identification process. All student information collected during the screening and identification process shall be an educational record, subject to the protections set out in policies at FL.
<b>Identification Criteria</b>	The Board-approved program for the gifted and talented shall establish criteria to identify gifted and talented students. The criteria shall be specific to the state definition of gifted and talented and shall ensure the fair assessment of students with special needs, such as the culturally different, the economically disadvantaged, and students with disabilities.
<b>Assessments</b>	Data collected through both objective and subjective assessments shall be measured against the criteria approved by the Board to determine individual eligibility for the program. Assessment tools may include, but are not limited to, the following: achievement tests, intelligence tests, creativity tests, behavioral checklists completed by teachers and parents, student/parent conferences, and available student work products.
<b>Selection</b>	A selection committee shall evaluate each referred student according to the established criteria and shall identify those students for whom placement in the gifted and talented program is the most appropriate educational setting. The committee shall be composed of at least three professional educators who have received training in the nature and needs of gifted students, as required by law.
<b>Notification</b>	The District shall provide written notification to parents of students who qualify for services through the District's gifted and talented program. Participation in any program or services provided for gifted students shall be voluntary, and the District shall obtain written permission from the parents before placing a student in a gifted and talented program.

<b>Reassessment</b>	If the District reassesses students in the gifted and talented program, the reassessment shall be based on a student's performance in response to services and shall occur no more than once in elementary grades, once in middle school grades, and once in high school grades.
<b>Transfer Students</b>	When a student identified as gifted by a previous school district enrolls in the District, the selection committee shall review the student's records and conduct assessment procedures when necessary to determine if placement in the District's program for gifted and talented students is appropriate.
Interdistrict	[See FDD(LEGAL) for information regarding transfer students and the Interstate Compact on Educational Opportunities for Military Children]
Intradistrict	A student who transfers from one campus in the District to the same grade level at another District campus shall continue to receive services in the District's gifted and talented program.
<b>Furloughs</b>	The District may place on a furlough any student who is unable to maintain satisfactory performance or whose educational needs are not being met within the structure of the gifted and talented program. A furlough may be initiated by the District, the parent, or the student.  In accordance with the Board-approved program, a furlough shall be granted for specified reasons and for a specified period of time. At the end of a furlough, the student may reenter the gifted and talented program, be placed on another furlough, or be exited from the program.
<b>Exit Provisions</b>	The District shall monitor student performance in response to gifted and talented program services. If at any time the selection committee or a parent determines it is in the best interest of the student to exit the program, the committee shall meet with the parent and student before finalizing an exit decision.
<b>Appeals</b>	A parent, student, or educator may appeal any final decision of the selection committee regarding selection for or exit from the gifted and talented program. Appeals shall be made first to the selection committee. Any subsequent appeals shall be made in accordance with FNG(LOCAL) beginning at Level Two.
<b>Program Evaluation</b>	The District shall annually evaluate the effectiveness of the District's gifted and talented program, and the results of the evaluation shall be used to modify and update the District and campus improvement plans. The District shall include parents in the evaluation process and shall share the information with Board members,

administrators, teachers, school counselors, students in the gifted and talented program, and the community.

### Funding

The District's gifted and talented program shall address effective use of funds for programs and services consistent with the standards in the state plan for gifted and talented students.

~~The District shall annually report to the Texas Education Agency (TEA) regarding funding used to implement the District's gifted and talented program. The District shall annually certify to TEA:~~

- ~~1. The establishment of a gifted and talented program by the District; and~~
- ~~2. That the District's program is consistent with the state plan for gifted and talented students.~~

### Community Awareness

The District shall ensure that information about the District's gifted and talented program is available to parents and community members and that they have an opportunity to develop an understanding of and support for the program.

<b>Course Requirements</b>	To graduate, a student must complete the courses required by the District in addition to the courses mandated by the state.
<b>Foundation Program</b>	The courses that satisfy District requirements under the foundation program, including courses for the distinguished level of achievement and courses for endorsements offered by the District, shall be listed in appropriate District publications.
Without an Endorsement	The District requires completion of 2 credits in addition to the number mandated by the state for graduation under the foundation program without an endorsement. Graduation under the foundation program without an endorsement shall be permitted only as authorized under state law and rules.
With an Endorsement	The District requires no additional credits beyond the number mandated by the state to graduate under the foundation program with an endorsement.
Distinguished Level of Achievement	The District requires no additional credits beyond the number mandated by the state to graduate under the foundation program with the distinguished level of achievement.
<b>No Fine Arts Substitutions</b>	The District shall not award state graduation credit in fine arts for participation in a community-based fine arts program.
<b>Physical Education Substitutions</b>	To the extent permitted by state rules, the District shall award state graduation credit in physical education for participation in approved activities and elective courses.
Activities and Courses	
No Private or Commercial Programs	The District shall not award state graduation credit in physical education for private or commercially sponsored physical activity programs conducted either on or off campus. [See also EHAC]
<b>Financial Aid Application Confirmation</b>	<p>As confirmation of a student's completion and submission of a free application for federal student aid (FAFSA) or a Texas application for state financial aid (TASFA), the District shall accept the following:</p> <ol style="list-style-type: none"><li>1. A screenshot that includes the processed date field in ApplyTexas Counselor Suite FAFSA data;</li><li>2. Notification, such as a copy of an email, from the United States Department of Education verifying completion of the FAFSA;</li><li>3. A copy or screenshot of the FAFSA acknowledgment page;</li><li>4. A screenshot of the TASFA submission acknowledgment page (from those institutions that offer an electronic form);</li></ol>

5. An acknowledgment receipt from an institution of higher education (IHE); or
6. A copy of a financial aid award letter from an IHE.

[For students who choose not to complete and submit a FAFSA or a TASFA, see EIF(LEGAL).]

The District shall maintain individual student documentation of the financial aid application requirement as an education record. [See FL]

**Trauma-Informed  
Care Program**

The District's trauma-informed care program, as included in the District improvement plan, shall provide for the integration of trauma-informed care practices in the school environment, including increasing staff and parent awareness of trauma-informed care, implementation of trauma-informed practices and care by District and campus staff, and providing information about available counseling options for students affected by trauma or grief.

Training

The District shall provide training in trauma-informed care to District educators as required by law [and the Board-approved District professional development plan](#). The District improvement plan shall specify required training for any other District employees as applicable.

Annual Report

~~The District shall provide an annual report to the Texas Education Agency on the number of employees who have participated in trauma-informed care training.~~

---

**Note:** This policy addresses discrimination, including harassment, and retaliation against District students. For provisions regarding discrimination, including harassment, and retaliation against District employees, see DIA. For reporting requirements related to child abuse and neglect, see FFG. Note that FFH shall be used in conjunction with FFI (bullying) for certain prohibited conduct.

---

**Statement of  
Nondiscrimination**

~~The District prohibits discrimination, including harassment, against any student on the basis of race, color, religion, sex, gender, national origin, age, disability, or any other basis prohibited by law. The District prohibits dating violence, as defined by this policy. Retaliation against anyone involved in the complaint process is a violation of District policy and is prohibited.~~

**Discrimination**

~~Discrimination against a student is defined as conduct directed at a student on the basis of race, color, religion, sex, gender, national origin, age, disability, or any other basis prohibited by law, that adversely affects the student.~~

**Prohibited Conduct**

In this policy, the term “prohibited conduct” includes discrimination, harassment, dating violence, and retaliation as defined by this policy, even if the behavior does not rise to the level of unlawful conduct.

Prohibited conduct also includes sexual harassment as defined by Title IX. [See FFH(LEGAL)]

**Prohibited  
Harassment  
Prohibited  
harassment**  
**Statement  
of  
Nondiscrimination**

The District prohibits discrimination, including harassment, against any student. Discrimination is defined as treating a student or group of students differently from similarly situated students on the basis of race, color, religion, sex, gender, national origin, age, disability, or any other basis prohibited by law. One type of harassment this policy prohibits is dating violence, as defined below. Retaliation against anyone exercising their rights under this policy is a violation of District policy and is prohibited.

**Harassment**

**Harassment** of a student is defined as physical, verbal, or nonverbal conduct based on the student’s race, color, religion, sex, gender, national origin, age, disability, or any other basis prohibited by law, when the conduct is so severe, persistent, or pervasive that the conduct:

1. Affects a student’s ability to participate in or benefit from an educational program or activity, or creates an intimidating, threatening, hostile, or offensive educational environment;

2. Has the purpose or effect of substantially or unreasonably interfering with the student's academic performance; or
3. Otherwise adversely affects the student's educational opportunities.

**Harassment** ~~Prohibited harassment~~ includes dating violence as defined by law and this policy.

Examples

Examples of prohibited harassment may include offensive or derogatory language directed at another person's religious beliefs or practices, accent, skin color, or need for accommodation; threatening, intimidating, or humiliating conduct; offensive jokes, name calling, slurs, or rumors; cyberharassment; physical aggression or assault; display of graffiti or printed material promoting racial, ethnic, or other negative stereotypes; or other kinds of aggressive conduct such as theft or damage to property.

**Title IX Sexual  
Based Harassment**

As required by law, the District shall follow the procedures below at Response to **Title IX Sexual Harassment**—~~Title IX~~ upon a report of sex-based harassment, including sexual harassment, gender-based harassment, and dating violence, when such allegations, if proved, would meet the definition of sexual harassment **in an education program or activity and against a person in the United States** under Title IX. [See FFH(LEGAL)]

**Other Sexual  
Harassment**

By an Employee

Sexual harassment of a student by a District employee includes both welcome and unwelcome sexual advances; requests for sexual favors; sexually motivated physical, verbal, or nonverbal conduct; or other conduct or communication of a sexual nature when:

1. A District employee causes the student to believe that the student must submit to the conduct in order to participate in a school program or activity, or that the employee will make an educational decision based on whether or not the student submits to the conduct; or
2. The conduct is so severe, persistent, or pervasive that it:
  - a. Affects the student's ability to participate in or benefit from an educational program or activity, or otherwise adversely affects the student's educational opportunities; or
  - b. Creates an intimidating, threatening, hostile, or abusive educational environment.

Romantic or other inappropriate social relationships between students and District employees are prohibited. Any sexual relationship between a student and a District employee is always prohibited, even if consensual. [See DH]

By Others

Sexual harassment of a student, including harassment committed by another student, includes unwelcome sexual advances; requests for sexual favors; or sexually motivated physical, verbal, or nonverbal conduct when the conduct is so severe, persistent, or pervasive that it:

1. Affects a student's ability to participate in or benefit from an educational program or activity, or creates an intimidating, threatening, hostile, or offensive educational environment;
2. Has the purpose or effect of substantially or unreasonably interfering with the student's academic performance; or
3. Otherwise adversely affects the student's educational opportunities.

Examples

Examples of sexual harassment of a student may include sexual advances; touching intimate body parts or coercing physical contact that is sexual in nature; jokes or conversations of a sexual nature; and other sexually motivated conduct, contact, or communications, including electronic communication.

Necessary or permissible physical contact such as assisting a child by taking the child's hand, comforting a child with a hug, or other physical contact not reasonably construed as sexual in nature is not sexual harassment.

**Gender-Based Harassment**

Gender-based harassment includes physical, verbal, or nonverbal conduct based on the student's gender, the student's expression of characteristics perceived as stereotypical for the student's gender, or the student's failure to conform to stereotypical notions of masculinity or femininity. For purposes of this policy, gender-based harassment is considered prohibited harassment if the conduct is so severe, persistent, or pervasive that the conduct:

1. Affects a student's ability to participate in or benefit from an educational program or activity, or creates an intimidating, threatening, hostile, or offensive educational environment;
2. Has the purpose or effect of substantially or unreasonably interfering with the student's academic performance; or
3. Otherwise adversely affects the student's educational opportunities.

Examples	Examples of gender-based harassment directed against a student, regardless of the student's or the harasser's actual or perceived sexual orientation or gender identity, may include offensive jokes, name-calling, slurs, or rumors; cyberharassment; physical aggression or assault; threatening or intimidating conduct; or other kinds of aggressive conduct such as theft or damage to property.
<b>Dating Violence</b>	Dating violence occurs when a person in a current or past dating relationship uses physical, sexual, verbal, or emotional abuse to harm, threaten, intimidate, or control the other person in the relationship. Dating violence also occurs when a person commits these acts against a person in a marriage or dating relationship with the individual who is or was once in a marriage or dating relationship with the person committing the offense.
	For purposes of this policy, dating violence is considered prohibited harassment if the conduct is so severe, persistent, or pervasive that the conduct:
	<ol style="list-style-type: none"><li>1. Affects a student's ability to participate in or benefit from an educational program or activity, or creates an intimidating, threatening, hostile, or offensive educational environment;</li><li>2. Has the purpose or effect of substantially or unreasonably interfering with the student's academic performance; or</li><li>3. Otherwise adversely affects the student's educational opportunities.</li></ol>
Examples	Examples of dating violence against a student may include physical or sexual assaults; name-calling; put-downs; or threats directed at the student, the student's family members, or members of the student's household. Additional examples may include destroying property belonging to the student, threatening to commit suicide or homicide if the student ends the relationship, attempting to isolate the student from friends and family, stalking, threatening a student's spouse or current dating partner, or encouraging others to engage in these behaviors.
<b>Reporting Procedures</b>	Any student who believes that he or she has experienced prohibited conduct <del>and any person who</del> believes that <del>a</del> another student has experienced prohibited conduct should immediately report the alleged acts to a teacher, school counselor, principal, other District employee, or the appropriate District official listed in this policy.
Student Report	
Employee Report	Any District employee who suspects or receives direct or indirect notice that a student or group of students has or may have experienced prohibited conduct shall immediately notify the appropriate District official listed in this policy and take any other steps required by this policy.

STUDENT WELFARE  
FREEDOM FROM DISCRIMINATION, HARASSMENT, AND RETALIATION

FFH  
(LOCAL)

Definition of District Officials	For the purposes of this policy, District officials are the Title IX coordinator, the ADA/Section 504 coordinator, and the Superintendent.
<i>Title IX Coordinator</i>	Reports of discrimination based on sex, including sexual harassment, gender-based harassment, or dating violence, may be directed to the designated Title IX coordinator for students. [See FFH(EXHIBIT)]
<i>ADA / Section 504 Coordinator</i>	Reports of discrimination based on disability may be directed to the designated ADA/Section 504 coordinator for students. [See FFH(EXHIBIT)]
<i>Superintendent</i>	The Superintendent shall serve as coordinator for purposes of District compliance with all other nondiscrimination laws.
<b>Alternative Reporting Procedures</b>	<p>An individual shall not be required to report prohibited conduct to the person alleged to have committed the conduct. Reports concerning prohibited conduct, including reports against the Title IX coordinator or ADA/Section 504 coordinator, may be directed to the Superintendent.</p> <p>A report against the Superintendent may be made directly to the Board. If a report is made directly to the Board, the Board shall appoint an appropriate person to conduct an investigation.</p>
<b>Timely Reporting</b>	To ensure the District's prompt investigation, reports of prohibited conduct shall be made as soon as possible after the alleged act or knowledge of the alleged act.
<b>Notice to Parents</b>	<p>The District official or designee shall promptly notify the parents of any student alleged to have experienced prohibited conduct by a District employee or another adult.</p> <p>[For parental notification requirements regarding an allegation of educator misconduct with a student, see FFF.]</p> <p>When the District receives a report of prohibited conduct that includes dating violence, the appropriate District official shall immediately notify the parent or guardian of the student who has been identified in the report as the alleged victim or perpetrator.</p>
<b>Investigation of Reports Other Than Title IX</b>	The following procedures apply to all allegations of prohibited conduct other than allegations of harassment prohibited by Title IX. [See FFH(LEGAL)] For allegations of sex-based harassment that, if proved, would meet the definition of sexual harassment under Title IX, including sexual harassment, gender-based harassment, and dating violence, see the procedures below at Response to <a href="#">Title IX Sexual Harassment—Title IX</a> .

STUDENT WELFARE  
FREEDOM FROM DISCRIMINATION, HARASSMENT, AND RETALIATION

FFH  
(LOCAL)

	<p>The District may request, but shall not require, a written report. If a report is made orally, the District official shall reduce the report to written form.</p>
Initial Assessment	<p>Upon receipt or notice of a report, the District official shall determine whether the allegations, if proved, would constitute prohibited conduct as defined by this policy. If so, the District shall immediately undertake an investigation, except as provided below at Criminal Investigation.</p> <p>If the District official determines that the allegations, if proved, would not constitute prohibited conduct as defined by this policy, the District official shall refer the complaint for consideration under FFI.</p>
Interim Action	<p>If appropriate and regardless of whether a criminal or regulatory investigation regarding the alleged conduct is pending, the District shall promptly take interim action calculated to address prohibited conduct or bullying prior to the completion of the District's investigation.</p>
District Investigation	<p>The investigation may be conducted by the District official or a designee, such as the principal, or by a third party designated by the District, such as an attorney. When appropriate, the principal shall be involved in or informed of the investigation.</p> <p>The investigation may consist of personal interviews with the person making the report, the person against whom the report is filed, and others with knowledge of the circumstances surrounding the allegations. The investigation may also include analysis of other information or documents related to the allegations.</p>
Criminal Investigation	<p>If a law enforcement or regulatory agency notifies the District that a criminal or regulatory investigation has been initiated, the District shall confer with the agency to determine if the District investigation would impede the criminal or regulatory investigation. The District shall proceed with its investigation only to the extent that it does not impede the ongoing criminal or regulatory investigation. After the law enforcement or regulatory agency has finished gathering its evidence, the District shall promptly resume its investigation.</p>
Concluding the Investigation	<p>Absent extenuating circumstances, such as a request by a law enforcement or regulatory agency for the District to delay its investigation, the investigation should be completed within ten District business days from the date of the report; however, the investigator shall take additional time if necessary to complete a thorough investigation.</p>

	<p>The investigator shall prepare a written report of the investigation. The report shall include a determination of whether prohibited conduct or bullying occurred. The report shall be filed with the District official overseeing the investigation.</p>
<i>Notification of Outcome</i>	<p>Notification of the outcome of the investigation shall be provided to both parties in compliance with FERPA.</p>
District Action <i>Prohibited Conduct</i>	<p>If the results of an investigation indicate that prohibited conduct occurred, the District shall promptly respond by taking appropriate disciplinary action in accordance with the Student Code of Conduct and may take corrective action reasonably calculated to address the conduct.</p>
Corrective Action	<p>Examples of corrective action may include a training program for those involved in the report, a comprehensive education program for the school community, counseling to the victim and the student who engaged in prohibited conduct, follow-up inquiries to determine if any new incidents or any instances of retaliation have occurred, involving parents and students in efforts to identify problems and improve the school climate, increasing staff monitoring of areas where prohibited conduct has occurred, and reaffirming the District's policy against discrimination, <del>and</del> harassment, <del>and</del> retaliation.</p>
<i>Bullying</i>	<p>If the results of an investigation indicate that bullying occurred, as defined by FFI, the District official shall refer to FFI for appropriate notice to parents and District action. The District official shall refer to FDB for transfer provisions.</p>
<i>Improper Conduct</i>	<p>If the investigation reveals improper conduct that did not rise to the level of prohibited conduct or bullying, the District may take disciplinary action in accordance with the Student Code of Conduct or other corrective action reasonably calculated to address the conduct.</p>
Confidentiality	<p>To the greatest extent possible, the District shall respect the privacy of the complainant, persons against whom a report is filed, and witnesses. Limited disclosures may be necessary in order to conduct a thorough investigation and comply with applicable law.</p>
Appeal	<p>A student or parent who is dissatisfied with the outcome of the investigation may appeal through FNG(LOCAL), beginning at the appropriate level. A student or parent <del>has the</del> <del>shall be informed of his or her</del> right to file a complaint with the United States Department of Education Office for Civil Rights.</p>

**Response to Title IX  
Sexual Harassment–  
Title IX**

General Response

For purposes of the District’s response to reports of harassment prohibited by Title IX, definitions can be found in FFH(LEGAL).

When the District receives notice or an allegation of conduct that, if proved, would meet the definition of sexual harassment under Title IX, the Title IX coordinator shall promptly contact the complainant to:

- Discuss the availability of supportive measures and inform the complainant that they are available, with or without the filing of a formal complaint;
- Consider the complainant’s wishes with respect to supportive measures; and
- Explain to the complainant the option and process for filing a formal complaint.

The District’s response to sexual harassment shall treat complainants and respondents equitably by offering supportive measures to both parties, as appropriate, and by following the Title IX formal complaint process before imposing disciplinary sanctions or other actions that are not supportive measures against a respondent.

If a formal complaint is not filed [or dismissed](#), the District reserves the right to investigate and respond to prohibited conduct in accordance with Board policies and the Student Code of Conduct. [The Title IX coordinator also reserves the right to sign a formal complaint, initiating the Title IX grievance process, if it would be deliberately indifferent not to investigate and respond to the prohibited conduct in accordance with Board policies and the Student Code of Conduct.](#)

Title IX Formal  
Complaint Process

To distinguish the process described below from the District’s general grievance policies [see DGBA, FNG, and GF], this policy refers to the grievance process required by Title IX regulations for responding to formal complaints of sexual harassment as the District’s “Title IX formal complaint process.”

The Superintendent shall ensure the development of a Title IX formal complaint process that complies with legal requirements. [See FFH(LEGAL)] The formal complaint process shall be posted on the District’s website. In compliance with Title IX regulations, the District’s Title IX formal complaint process shall address the following basic requirements:

1. Equitable treatment of complainants and respondents;
2. An objective evaluation of all relevant evidence;

3. A requirement that the Title IX coordinator, investigator, decision-maker, or any person designated to facilitate an informal resolution process not have a conflict of interest or bias;
4. A presumption that the respondent is not responsible for the alleged sexual harassment until a determination is made at the conclusion of the Title IX formal complaint process;
5. Time frames that provide for a reasonably prompt conclusion of the Title IX formal complaint process, including time frames for appeals and any informal resolution process, and that allow for temporary delays or the limited extension of time frames with good cause and written notice as required by law;
6. A description of the possible disciplinary sanctions and remedies that may be implemented following a determination of responsibility for the alleged sexual harassment;
7. A statement of the standard of evidence to be used to determine responsibility for all Title IX formal complaints of sexual harassment;
8. Procedures and permissible bases for the complainant and respondent to appeal a determination of responsibility or a dismissal of a Title IX formal complaint or any allegations therein;
9. A description of the supportive measures available to the complainant and respondent;
10. A prohibition on using or seeking information protected under a legally recognized privilege unless the individual holding the privilege has waived the privilege;
11. Additional formal complaint procedures in 34 C.F.R. 106.45(b), including written notice of a formal complaint, consolidation of formal complaints, recordkeeping, and investigation procedures; and
12. Other local procedures as determined by the Superintendent.

Standard of Evidence

The standard of evidence used to determine responsibility in a Title IX formal complaint of sexual harassment shall be the preponderance of the evidence.

**Retaliation**

The District prohibits retaliation by a student or District employee against a student alleged to have experienced discrimination or harassment, including dating violence, or another student who, in good faith, makes a report of harassment or discrimination, files a complaint of harassment or discrimination, serves as a witness, or participates in an investigation. The definition of prohibited retaliation under this policy also includes retaliation against a student

who refuses to participate in any manner in an investigation under Title IX. [In the absence of a formal complaint, allegations of retaliation shall be investigated under Investigation of Reports Other Than Title IX, above.](#)

**Examples**

Examples of retaliation may include threats, intimidation, coercion, rumor spreading, ostracism, assault, destruction of property, unjustified punishments, or unwarranted grade reductions. Unlawful retaliation does not include petty slights or annoyances.

**False Claim**

A student who intentionally makes a false claim or offers false statements in a District investigation regarding discrimination or harassment, including dating violence, shall be subject to appropriate disciplinary action in accordance with law.

**Records Retention**

The District shall retain copies of allegations, investigation reports, and related records regarding any prohibited conduct in accordance with the District's records control schedules, but for no less than the minimum amount of time required by law. [See CPC]

[For Title IX recordkeeping and retention provisions, see FFH(LEGAL) and the District's Title IX formal complaint process.]

**Access to Policy and Procedures**

Information regarding this policy and any accompanying procedures shall be distributed annually in the employee and student handbooks. Copies of the policy and procedures shall be posted on the District's website, to the extent practicable, and readily available at each campus and the District's administrative offices.

## Policy Update 119

1. CPC (Local)
  - i. Adds new provisions to address electronic records management
  - ii. Delegates an employee to develop procedures for managing electronic records
2. DMA (Local)
  - i. Meets requirement for board to have a professional development policy
  - ii. Requires the board to approve an annual professional development plan
3. EHAA (Local)
  - i. Addresses instruction in child abuse, family violence, dating violence, and sex trafficking
  - ii. Clarifies the role of the student health advisory council (SHAC) in this process
4. EBH (Local)
  - i. Addresses dyslexia training for teachers in new policy
5. EHBAA (Local)
  - i. Addresses the IEP for a student transitioning from early childhood intervention in new policy
6. EHBB (Local)
  - i. Removes requirement to annually submit to the commissioner of education a certification of the district's gifted and talented program
7. EIF (Local)
  - i. Addresses acceptable documentation that a student has submitted a financial aid application
8. FFBA (Local)
  - i. Trauma-informed care training will be in accordance with professional development plan
  - ii. Removes the requirement to report the number of employees that received trauma-informed training
9. FFH (Local)
  - i. Requires the district to notify the parent of an alleged victim or perpetrator when it receives a report of dating violence
  - ii. Ensures that the current policy includes reporting procedures and a statement prohibiting dating violence
  - iii. Clarify provisions that define prohibited conduct and the district's response

# Medina Valley Independent School District

## *Agenda Item Memorandum*

*To: MVISD Board of Trustees*

*Date: 9-19-2022*

*RE: Consider approving Consent Agenda Items*

The following Consent Agenda Items need to be considered for approval:

- 5 sets of Board Meeting minutes
- Donation of backpacks valued over \$500 from Walmart
- Donation of 2 vehicles for CTE from Linda Lancaster, each vehicle valued over \$500
- FFA out of state travel request to the National FFA Convention for student serving as a voting delegate

**Medina Valley Independent School District**  
**Regular School Board Meeting**

Board Minutes

August 15, 2022, 6:30 PM

Medina Valley ISD Central Office Board Room

A **Regular Board Meeting** of the Board of Trustees was held Monday, August 15, 2022, beginning at 6:30 PM at the Medina Valley ISD Central Office Board Room.

**I. First Order of Business**

**A Establish a Quorum**

Beth Zinsmeyer, Board President, called the Medina Valley ISD Regular Board Meeting to order at 6:30 pm. A quorum of the Board Members were present, Jennilea Campbell, Shannon Beasley, Veronica Cavazos, Matt Castiglione, Mario De Leon, Paula Davidson, and Beth Zinsmeyer.

**B Pledge of Allegiance to the Flag followed by a moment of silence**

Everyone joined in the Pledge of Allegiance to the Flag followed by a moment of silence.

**II. Announcements/Communications/Presentations**

**A** Tanya Stivors presented the Safety and Security Update.

**B** JC Zamora presented the monthly Financial Briefing.

**C** JC Zamora presented a Bond 2016 and Bond 2019 Review.

**D** JC Zamora presented a Transportation Update.

**E** Dr. Caloss presented the monthly Superintendent Briefing

**III. Public Comment**

Terry Beck, Topic: General

Hank Seay, Topic: General

Oh Rash, Topic: General

**IV. Discussion and Possible Action Items**

**A Consent Agenda Items (Dr. Caloss)**

- 1 Minutes of Regular Board Meeting on July 18, 2022 and Special Board Meetings on June 6, July 26, and August 9, 2022

Jennilea Campbell made a Motion, seconded by Mario De Leon, to approve the consent agenda items as presented. All of the Board Members voted for and the Motion passed.

**Medina Valley Independent School District**  
**Regular School Board Meeting**

Board Minutes

August 15, 2022, 6:30 PM

Medina Valley ISD Central Office Board Room

- B Consider Property Insurance coverage from TASB Risk Management Fund (JC Zamora)

Matt Castiglione made a Motion, seconded by Veronica Cavazos, to approve the Property Insurance agreement from the TASB Risk Management Fund as presented. All of the Board Members voted for and the Motion passed.

- C Consider the Architect recommendation for the high school #2 project (JC Zamora)

Paula Davidson made a Motion, seconded by Jennilea Campbell, to approve O'Connell Roberts as the Architect for the high school #2 project as presented. All of the Board Members voted for and the Motion passed.

- D Board Committees Reorganization (Dr. Caloss)

Beth Zinsmeyer, Board President, appointed the Board Members to the following Board Committees.

- **Curriculum Committee**  
Paula Davidson, Jennilea Campbell & Veronica Cavazos
- **Finance and Operations Committee**  
Matt Castiglione, Beth Zinsmeyer & Jennilea Campbell
- **Construction Committee**  
Mario De Leon, Paula Davidson, & Shannon Beasley

- E Consider 2022-2023 T-TESS Appraisal Calendar and Appraisers (Dr. Caloss)

Mario De Leon made a Motion, seconded by Matt Castiglione, to approve the 2022-2023 T-TESS Calendar and Appraisers as presented. All of the Board Members voted for and the Motion passed.

**V. Closed Session**

The Board President, Beth Zinsmeyer announced that in accordance with the Texas Open Meetings Act, under the exceptions noted in TX Govt. Code Section 551.074 Personnel Matters and TX Govt. Code 551.072 Deliberation Regarding Real Property, and TX Govt. Code Section 551.076 Considering the deployment, specific occasions for, or implementation of, security personnel or devices, that the Board of Trustees would convene into a closed meeting at 7:29 pm.

- A Personnel Matters (TX Govt. Code Section 551.074)
- B Deliberation Regarding Real Property (TX Govt. Code Section 551.072)
- C Considering the deployment, specific occasions for, or implementation of, security personnel or devices (TX Govt. Code Section 551.076)

**Medina Valley Independent School District**  
**Regular School Board Meeting**

Board Minutes

August 15, 2022, 6:30 PM

Medina Valley ISD Central Office Board Room

Board President Beth Zinsmeyer announced that the Board would reconvene into Open Session at 8:45 pm.

**VI. Continued Discussion and Possible Action Items**

**A Consider professional contract recommendations (Dr. Caloss)**

Matt Castiglione made a Motion, seconded by Veronica Cavazos, to approve the contract recommendations by the Superintendent for professional contracts as presented. All of the Board Members voted for and the Motion passed.

Congratulations to the following Medina Valley new hires:

- Vasti Ruiz, Loma Alta Teacher

**B Consider the purchase of district safety items as discussed in closed**

Paula Davidson made a Motion, seconded by Mario De Leon, to approve the purchase of district safety items as discussed in closed. All of the Board Members voted for and the Motion passed.

**C Consider Procurement Method for safety project as discussed in closed  
(JC Zamora)**

Matt Castiglione made a Motion, seconded by Jennilea Campbell, to approve competitive sealed proposal as the procurement method for the safety projects as discussed in closed. All of the Board Members voted for and the Motion passed.

**D Consider adopting a Resolution approving the purchase of an approximate **20.89-acre** tract of real property located in Medina County, Texas and authorizing the Superintendent to act on behalf of the Board to enter into a Contract for the Purchase of Real Estate in substantially the same form as presented to the Board.**

Veronica Cavazos made a Motion, seconded by Jennilea Campbell, to adopt a Resolution approving the purchase of an approximate 20.89-acre tract of real property located in Medina County, Texas and authorizing the Superintendent to act on behalf of the Board to enter into a Contract for the Purchase of Real Estate in substantially the same form as presented to the Board. All of the Board Members voted for and the Motion passed.

**E Consider the GMP (Guaranteed Maximum Price) for Elementary #6**

Paula Davidson made a Motion, seconded by Veronica Cavazos, to approve and accept the Guaranteed Maximum Price proposal submitted by the Construction Manager-at-Risk for the construction of Elementary School #6 located in the Silos Subdivision, in the amount of \$42,139,608.00 and authorize the Superintendent to negotiate and execute the final GMP

**Medina Valley Independent School District  
Regular School Board Meeting**

Board Minutes

August 15, 2022, 6:30 PM

Medina Valley ISD Central Office Board Room

Amendment to the Construction Manager-at-Risks's Contract, in a form approved by counsel for the District. All of the Board Members voted for and the Motion passed.

F Consideration of future meeting dates

- Special Meeting on August 29th (adoption of the 2022-2023 Budget and set the tax rate)
- Regular Meeting on September 19, 2022

**VII. Adjournment**

Matt Castiglione made a Motion, seconded by Mario De Leon, to adjourn the Regular Board Meeting at 8:50 pm on August 15, 2022. All of the Board Members voted for and the Motion passed.

\_\_\_\_\_  
Beth Zinsmeyer, Board President

\_\_\_\_\_  
Jennilea Campbell, Board Secretary

Board Approved \_\_\_\_\_

**Medina Valley Independent School District  
Special School Board Meeting**

Board Minutes

August 29, 2022, 6:30 PM

Medina Valley ISD Central Office Board Room

A **Special Board Meeting** of the Board of Trustees was held Monday, August 29, 2022, beginning at 6:30 PM at the Medina Valley ISD Central Office Board Room.

**I. First Order of Business**

A Establish a Quorum

Beth Zinsmeyer, Board President, called the Medina Valley ISD Special Board Meeting to order at 6:30 pm. A quorum of the Board Members were present, Jennilea Campbell, Shannon Beasley, Veronica Cavazos, Matt Castiglione, Mario De Leon, Paula Davidson, and Beth Zinsmeyer.

B Pledge of Allegiance to the Flag followed by a moment of silence

Everyone joined in the Pledge of Allegiance to the Flag followed by a moment of silence.

**II. Public Hearing for the 2022-2023 Budget and the 2022 Tax Rate (JC Zamora)**

A Budget Presentation and Tax Rate Presentation

B Receive Public Comments on the Proposed 2022-2023 Budget and the 2022 Tax Rate

**III. Public Comment**

Hank Seay, Topic: Agenda Items  
Terry Beck, Topic: Agenda Items  
Emily Davis, Topic: Tax Rate  
Michelle Hayden, Topic: Tax Rate  
Joe Davis, Topic: Tax Rate  
Sarah Baker, Topic: Tax Rate

**IV. Discussion and Possible Action Items**

A Consider a Resolution providing for the defeasance and calling for redemption certain currently outstanding District obligations and other matters in connection therewith (JC Zamora)

Jennilea Campbell made a Motion, seconded by Mario De Leon, to approve the district's defeasance resolution as presented. All of the Board Members voted for and the Motion passed.

**Medina Valley Independent School District  
Special School Board Meeting**

Board Minutes

August 29, 2022, 6:30 PM

Medina Valley ISD Central Office Board Room

**B Consider 2021-2022 Final Amended Budget (JC Zamora)**

Shannon Beasley made a Motion, seconded by Jennilea Campbell, to approve the 2021-2022 final amended budget as presented. All of the Board Members voted for and the Motion passed.

**C Accept the Certified Appraisal Rolls for Medina Valley Independent School District (JC Zamora)**

Mario De Leon made a Motion, seconded by Matt Castiglione, to accept the certified appraisal rolls for the tax year 2022 from Medina County and Bexar County for Medina Valley Independent School District as presented. All Board Members voted for and the Motion passed.

**D Consider Adoption of 2022-2023 Budget (JC Zamora)**

Shannon Beasley made a Motion, seconded by Jennilea Campbell, to adopt the 2022-2023 Budgets as presented. All of the Board Members voted for and the Motion passed.

**E Consider No-New-Revenue Tax Rate and Voter-Approval Tax Rate for Tax Year 2022 for Medina Valley Independent School District (JC Zamora)**

Shannon Beasley made a Motion, seconded by Mario De Leon, to approve the “No-New-Revenue Tax Rate” and the “Voter-Approval Tax Rate” for the Tax Year 2022 as presented. All of the Board Members voted for and the Motion passed.

**F Consideration and Approval of Ordinance to Set the Medina Valley Independent School District Tax Rate for 2022 (JC Zamora)**

Mario De Leon made a Motion, seconded by Jennilea Campbell, to approve that the Medina Valley Independent School District’s property tax rate be increased by the adoption of a tax rate of 1.326790, which is effectively a 21.11 percent increase in the tax rate.

Paula Davidson voted against, Matt Castiglione voted for, Shannon Beasley voted for, Jennilea Campbell voted for, Mario De Leon voted for, Veronica Cavazos voted for, and Beth Zinsmeyer voted for. The Motion passed.

**V. Closed Session**

The Board President, Beth Zinsmeyer announced that in accordance with the Texas Open Meetings Act, under the exceptions noted in TX Govt. Code Section 551.074 Personnel Matters and TX Govt. Code 551.072 Deliberation Regarding Real Property, and TX Govt. Code Section 551.071 Consultation with Attorney, that the Board of Trustees would convene into a closed meeting at 7:31 pm.

**A Consultation with Attorney (TX Govt. Code Section 551.071)**

**Medina Valley Independent School District  
Special School Board Meeting**

Board Minutes

August 29, 2022, 6:30 PM

Medina Valley ISD Central Office Board Room

- The Board will consult with its legal counsel regarding legal issues relating to an employee grievance.
- B Personnel Matters (TX Govt. Code Section 551.074)
  - Consider Professional Contracts
  - The Board will hear the Level III grievance of Debra Keller.
- C Deliberation Regarding Real Property (TX Govt. Code Section 551.072)

Board President Beth Zinsmeyer announced that the Board would reconvene into Open Session at 9:05 pm.

**VI. Continued Discussion and Possible Action Items**

- A Consider professional contract recommendations (Dr. Caloss)

Matt Castiglione made a Motion, seconded by Veronica Cavazos, to approve the contract recommendations by the Superintendent for professional contracts as presented. All of the Board Members voted for and the Motion passed.

Congratulations to the following Medina Valley ISD new hires:

- Kristina Dalton, Luckey Ranch Elementary Teacher
- Brandy White, MVHS Teacher
- Vanessa Bejarano, Potranco Elementary Teacher

- B Consider and take possible action regarding the Level III grievance of Debra Keller

Paula Davidson made a Motion, seconded by Matt Castiglione, to GRANT the Level Three grievance of Debra Keller. Paula Davidson voted for, Matt Castiglione voted for, Shannon Beasley voted against, Jennilea Campbell voted against, Mario De Leon abstained, Veronica Cavazos voted against, and Beth Zinsmeyer voted against. The Motion failed.

**VII. Adjournment**

Paula Davidson made a Motion, seconded by Veronica Cavazos, to adjourn the Special Board Meeting at 9:07 pm on August 29, 2022. All of the Board Members voted for and the Motion passed.

\_\_\_\_\_  
Beth Zinsmeyer, Board President

\_\_\_\_\_  
Jennilea Campbell, Board Secretary

Board Approved \_\_\_\_\_

**Medina Valley Independent School District  
Special School Board Meeting**

Board Minutes

September 2, 2022, 7:30 AM

Medina Valley ISD Central Office Board Room

A **Special Board Meeting** of the Board of Trustees was held Friday, September 2, 2022, beginning at 7:30 AM at the Medina Valley ISD Central Office Board Room.

**I. First Order of Business**

**A Establish a Quorum**

Beth Zinsmeyer, Board President, called the Medina Valley ISD Special Board Meeting to order at 7:30 am. A quorum of the Board Members were present, Shannon Beasley, Veronica Cavazos, Matt Castiglione, Mario De Leon, Paula Davidson, and Beth Zinsmeyer.

Jennilea Campbell was absent.

**B Pledge of Allegiance to the Flag followed by a moment of silence**

Everyone joined in the Pledge of Allegiance to the Flag followed by a moment of silence.

**II. Public Comment**

Eric Cherry, Topic: Transportation

**III. Discussion and Possible Action Items**

**A Consider Bus Driver Incentive Program (JC Zamora)**

Veronica Cavazos made a Motion, seconded by Mario De Leon, to approve the Bus Driver Incentive Program, setting the maximum payout at \$5000.00, and granting the Superintendent the authority to determine the disbursement schedule. All of the Board Members voted for and the Motion passed.

**IV. Adjournment**

Matt Castiglione made a Motion, seconded by Paula Davidson, to adjourn the Special Board Meeting at 8:18 am on September 2, 2022. All of the Board Members voted for and the Motion passed.

\_\_\_\_\_  
Beth Zinsmeyer, Board President

\_\_\_\_\_  
Jennilea Campbell, Board Secretary

Board Approved \_\_\_\_\_

**Medina Valley Independent School District**  
**Workshop Board Meeting**

Board Minutes

September 13, 2022, 6:00 PM

Medina Valley ISD Central Office Board Room

A **Workshop Board Meeting** of the Board of Trustees was held Tuesday, September 13, 2022, beginning at 6:00 PM at the Medina Valley ISD Central Office Board Room.

**I. First Order of Business**

**A Establish a Quorum**

Beth Zinsmeyer, Board President, called the Medina Valley ISD Workshop Board Meeting to order at 7:30 am. A quorum of the Board Members were present, Jennilea Campbell, Shannon Beasley, Veronica Cavazos, Paula Davidson, and Beth Zinsmeyer.

Mario De Leon and Matt Castiglione were absent.

**B Pledge of Allegiance to the Flag followed by a moment of silence**

Everyone joined in the Pledge of Allegiance to the Flag followed by a moment of silence.

**Public Comment**

Hank Seay, Topic: Board Policy

Terry Beck, Topic: Board Policy

**II. MVISD Board Policy Review Workshop (Dr. Caloss)**

Lexi O’Hair our Board Policy Consultant with TASB conducted the Board Workshop about MVISD Board Policy.

**III. Adjournment**

Veronica Cavazos made a Motion, seconded by Shannon Beasley, to adjourn the Board Workshop at 7:18 pm on September 13, 2022. All of the Board Members voted for and the Motion passed.

\_\_\_\_\_  
Beth Zinsmeyer, Board President

\_\_\_\_\_  
Jennilea Campbell, Board Secretary

Board Approved \_\_\_\_\_



# MEDINA VALLEY INDEPENDENT SCHOOL DISTRICT

*"Proud of our past, dedicated to the present, committed to the Future"*

## Request for Board Acceptance of Donation

(\$501 and above including items valued at \$501 and above)

School/Department: CTE Dept - Medina Valley High School

Donor: Linda Lancaster

Address: \_\_\_\_\_  
\_\_\_\_\_

Donor Contact Name: Linda Lancaster

Donor Contact Phone: 210.289.9348

Revenue Account for the deposit: \_\_\_\_\_

Description of item/s donated:  
1999 Toyota Sienna

683.00

\_\_\_\_\_  
\_\_\_\_\_

### Medina Valley ISD Board Action Required

Approved    or    Disapproved    Date: \_\_\_\_\_

# MEDINA VALLEY INDEPENDENT SCHOOL DISTRICT

*"Proud of our past, dedicated to the present, committed to the Future"*

## Request for Board Acceptance of Donation

(\$501 and above including items valued at \$501 and above)

School/Department: CTE Dept - Medina Valley High School

Donor: Linda Lancaster

Address: \_\_\_\_\_  
\_\_\_\_\_

Donor Contact Name: Linda Lancaster

Donor Contact Phone: 210.289.9348

Revenue Account for the deposit: \_\_\_\_\_

Description of item/s donated:

2005 Dodge Durango Hemi

593.00

**Current Directions (September 2021):**

Please send the check/cash donation, \$501 or more, with completed donation request form to the Superintendent's office when you receive it. We will handle the deposit and notify you after the approval is received and deposit is made.

Items valued at \$501 or more, please send the completed donation request form, please do not send the items.

**Medina Valley ISD Board Action Required**

Approved      or      Disapproved      Date: \_\_\_\_\_

August 25, 2022

Subject: FFA Fall Overnight Travel (Out-of-State)

Medina Valley ISD Administration:

Last May, Emma Muller, Medina Valley FFA President, was elected to serve as an Area 7 FFA Vice President by her peers through an election process. Part of her annual duties require her to serve as a voting delegate for Texas at the National FFA Convention. This event will count as a national participation on her Texas FFA Scholarship application and will be very beneficial to her.

The Area 7 FFA Officer Team will be accompanied and escorted by the Area 7 Association Advisors to Indianapolis, Indiana. Emma's flight, hotel, and registration will be funded by the Area 7 FFA Association.

National FFA Convention  
Indianapolis, Indiana  
October 24th-October 29th

Texas delegates will be at the Westin Indianapolis located at 241 W Washington Street, Indianapolis, Indiana. More information can be found at this link.  
<https://convention.ffa.org/schedule/>

Please let us know if you have any questions. We are very proud of Emma and her year of service to the Area 7 FFA Association. Thank you!

Kyla Williamson, Rodger Welch, and Eric Davis  
Agriculture Science Teachers and FFA Advisors  
Medina Valley High School

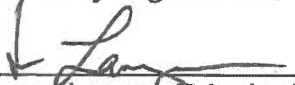
 8/25/22  
\_\_\_\_\_  
Mr. Tanner Lange, Principal

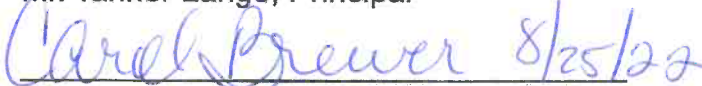
 8/25/22  
\_\_\_\_\_  
Ms. Carol Brewer, CTE Director

\_\_\_\_\_  
Dr. Scott Caloss, Superintendent

# Medina Valley Independent School District

## *Agenda Item Memorandum*

*To: MVISD Board of Trustees*

*Date: September 19, 2022*

*RE: Consider approving Resolutions for Extracurricular Status of 4-H Organizations for Medina County and Bexar County*

Each year, the Board is asked to recognize 4-H as an extracurricular activity within the district, as per 19 Texas Administrative Code, Chapter 76.1, pertaining to extracurricular activities. This allows the students participating in 4-H activities to have excused absences for those activities. We have students that participate in 4-H in Medina and Bexar Counties.

**RESOLUTION**  
**EXTRACURRICULAR STATUS OF 4-H ORGANIZATION**

Be it hereby resolved that upon this date, the duly elected Board of Trustees of the

MEDINA VALLEY ISD

meeting in public with a quorum present and certified,  
did adopt this resolution that recognizes the

MEDINA

County Texas 4-H Organization as approved for recognition and eligible for  
extracurricular status consideration under 19 Texas Administrative Code, Chapter 76.1,  
pertaining to extracurricular activities.

Participation by 4-H members under provisions of this resolution are subject to all rules and regulations set forth under the 19 Texas Administrative Code as interpreted by this Board and designated officials of this school district whose rules shall be final.

Texas A&M AgriLife Extension will request academic eligibility for competitive activities, regardless if a school absence is or is not required, and for non-competitive purposes when an absence is required.

Approved this \_\_\_\_\_ day of \_\_\_\_\_, 2022

\_\_\_\_\_  
Board of Trustee

\_\_\_\_\_  
Superintendent

# EXTRACURRICULAR STATUS REQUEST

## RESOLUTION

### EXTRACURRICULAR STATUS OF 4-H ORGANIZATION

Be it hereby resolved that upon this date, the duly elected Board of Trustees of the

\_\_\_\_\_  
Medina Valley Independent School District

meeting in public with a quorum present and certified,  
did adopt this resolution that recognizes the

\_\_\_\_\_  
Bexar

County Texas 4-H Organization as approved for recognition and eligible  
for extracurricular status consideration under 19 Texas Administrative Code,  
Chapter 76.1, pertaining to extracurricular activities.

Participation by 4-H members under provisions of this resolution are subject  
to all rules and regulations set forth under the 19 Texas Administrative Code  
as interpreted by this Board and designated officials of this school district.

Texas A&M AgriLife Extension  
will request academic eligibility for all 4-H competitive activities,  
regardless if a school absence is or is not required, and  
for non-competitive purposes when an absence is required.

Approved this \_\_\_\_\_ day of \_\_\_\_\_, 20\_\_\_\_\_.

\_\_\_\_\_  
Board of Trustee

\_\_\_\_\_  
Superintendent

# Medina Valley Independent School District

## *Agenda Item Memorandum*

*To: MVIDS Board of Trustees*

*Date: September 19, 2022*

*RE: Consider approving the Adjunct Faculty agreements with Medina County and Bexar County*

Each year, the Board is asked to grant adjunct faculty status to county extension agents in counties that have been approved for extracurricular status for 4-H. The State Board of Education passed an amendment to 19 TAC§129.21(j). Requirements for student attendance accounting for state funding purposes allows public school students to be considered “in attendance” when participating in off-campus activities with an adjunct staff member of the school district. Section 3 of the Student Attendance Handbook states:

- (1) The student is participating in an activity that is approved by the local board of trustees and is under the direction of the professional or paraprofessional staff of the school district or an adjunct staff member who:
  - (A) Has a minimum of a bachelor’s degree; and
  - (B) Is eligible for participation in the Teacher Retirement System of Texas.

**THE STATE OF TEXAS  
COUNTY OF MEDINA**

On this date, at a regularly scheduled and posted meeting, came the Board of Trustees of the Medina Valley Independent School District, hereinafter referred to as “District”. A quorum having been established, the Board proceeded to consider the appointment of the herein named individual as an adjunct member of the Medina Valley Independent School District.

Upon consideration and vote of \_\_\_\_\_ in favor, Taryn Titsworth and/or Elyse Hernandez are hereby named as adjunct faculty member(s) of the Medina Valley Independent School District subject to the following consideration and provisions of such appointment to wit:

1. This appointment shall commence on the \_\_\_\_\_ day of \_\_\_\_\_, 20\_\_\_\_ and remain in effect until the \_\_\_\_\_ day of \_\_\_\_\_, 20\_\_\_\_\_.

2. This appointment will include the Texas A&M AgriLife Extension Service employees listed below:

NAME	TITLE	DEGREE	INSTITUTION	DATE
Taryn Titsworth	County Extension Agent	BS	ASU	2018
Elyse Hernandez	County Extension Agent	BS	UTSA	2020

3. Adjunct faculty member(s) will receive no compensation, salary, or remuneration from Medina Valley Independent School District.
4. Adjunct faculty member(s) is and shall remain an employee, in good standing, of the Texas A&M AgriLife Extension Service.
5. Adjunct faculty member(s) is and shall remain under the direct supervision of the District Extension Administrator of District 10.
6. Adjunct faculty member(s) shall receive all group insurance benefits, workman’s compensation insurance benefits, unemployment insurance, and any and all other plans for the benefit of Texas A&M AgriLife Extension Service employees. District shall have no responsibility for any of such benefits or plans.

Adjunct faculty member(s) shall direct the activities and participation of students of the school district in sponsored and approved activities as designated from time to time by adjunct faculty members for which notice shall be given to School District administrative personnel. Adjunct faculty members’ activities and participation with students of the School District are directed, supervised, and controlled by and through supervisory personnel of Texas A&M AgriLife Extension Service pursuant to the supervisory authority of the District Extension Administrator or County Extension Director. Adjunct faculty member(s) is not the employee of the School District, and School District does not nor shall not supervise, direct or control the activities and/or participation of Medina County Extension Agent(s) who have/has been herein designated as an adjunct faculty member.

This appointment is made by the Independent School District by and through the Board of Trustees of said district for the benefit of allowing voluntary student participation in programs conducted by the Texas A&M AgriLife Extension Service in recognition of the educational benefits arising from such participation and activities and/or directed by the Texas A&M AgriLife Extension Service. This appointment is made in accordance with the provisions of Section 129.21(j)(1) of the Texas Administrative Code authorizing the school to deem such participating students in attendance for foundation school program purposes.

This appointment of the herein named Taryn Titsworth and/or Elyse Hernandez, County Extension Agents is not intended nor shall be construed as a waiver of any claim or defense of sovereign or governmental immunity from liability now possessed by Medina Valley Independent School District or any of its employees, agents, officers, and/or board members in the performance of governmental functions.

Signed this \_\_\_\_\_ day of \_\_\_\_\_, 2022

Medina Valley Independent School District

By: \_\_\_\_\_

# ADJUNCT FACULTY REQUEST

THE STATE OF TEXAS

COUNTY OF Bexar

On this date, at a regularly scheduled and posted meeting, came the Board of Trustees of the Medina Valley Independent School District, hereinafter referred to as "District." A quorum having been established, the Board proceeded to consider the appointment of the herein named individual(s) as an adjunct member of the Medina Valley Independent School District.

Upon consideration and vote of Kevin Knapick, Angie Gutierrez, Sam Womble, and David Rodriguez in favor, Sam Womble, and David Rodriguez is hereby named as adjunct faculty member(s) of the Medina Valley Independent School District subject to the following considerations and provisions of such appointment to wit:

1. This appointment shall commence on the \_\_\_\_\_ day of \_\_\_\_\_, 20\_\_\_\_ and remain in effect until the \_\_\_\_\_ day of \_\_\_\_\_, 20\_\_\_\_\_.
2. This appointment will include the Texas A&M AgriLife Extension Service employees listed below:

NAME	TITLE	DEGREE	INSTITUTION	DATE
Kevin Knapick	County Extension Agent	Renewable Natural Resources and Forestry	Texas A&M University	5-14-2016
Angie Gutierrez	County Extension Agent	Child Studies	University of the Incarnate Word	8-3-2012
Sam Womble	County Extension Agent	Animal Science	Texas A&M University	12-19-1997
David Rodriguez	County Extension Agent	Horticulture	Texas A&M University	1990

3. Adjunct faculty member(s) will receive no compensation, salary, or remuneration from Medina Valley Independent School District.
4. Adjunct faculty member(s) is and shall remain an employee, in good standing, of the Texas A&M AgriLife Extension Service.
5. Adjunct faculty member(s) is and shall remain under the direct supervision of either the District Extension Administrator of District 10 or Bexar County Extension Director.
6. Adjunct faculty member(s) shall receive all group insurance benefits, workman's compensation insurance benefits, unemployment insurance, and any and all other plans for the benefit of Texas A&M AgriLife Extension Service employees. District shall have no responsibility for any of such benefits or plans.

Adjunct faculty member(s) shall direct the activities and participation of students of the school district in sponsored and approved activities as designated from time to time by adjunct faculty members for which notice shall be given to School District administrative personnel. Adjunct faculty members' activities and participation with students of the School District are directed, supervised, and controlled by and through supervisory personnel of Texas A&M AgriLife Extension Service pursuant to the supervisory authority of the District Extension Administrator or County Extension Director. Adjunct faculty member(s) is not the employee of the School District, and School District does not nor shall not supervise, direct or control the activities and/or participation of such Bexar County Extension Agent(s) who have/has been herein designated as an adjunct faculty member.

This appointment is made by the Independent School District by and through the Board of Trustees of said district for the benefit of allowing voluntary student participation in programs conducted by the Texas A&M AgriLife Extension Service in recognition of the educational benefits arising from such participation and activities and/or directed by the Texas A&M AgriLife Extension Service. This appointment is made in accordance with the provisions of Section 129.21 (j)(1) of the Texas Administrative Code authorizing the school to deem such participating students in attendance for foundation school program purposes.

This appointment of the herein named Bexar County Extension Agent(s), Kevin Knapick, Angie Gutierrez Sam Womble, David Rodriguez (Extension employee) is/are not intended nor shall be construed as a waiver of any claim or defense of sovereign or governmental immunity from liability now possessed by Medina Valley Independent School District or any of its employees, agents, officers, and/or board members in the performance of governmental functions.

Signed this \_\_\_\_\_ day of \_\_\_\_\_, 20\_\_.

\_\_\_\_\_ Medina Valley \_\_\_\_\_ Independent School District

By: \_\_\_\_\_

# Medina Valley Independent School District

## *Agenda Item Memorandum*

*To: MVIDS Board of Trustees*

*Date: September 19, 2022*

*RE: Consider approving the recommendation for the School Health Advisory Council (SHAC) membership for 2022-2023*

Per Board Policy BDF the Board will be presented with the annual report from the School Health Advisory Council and asked to consider the recommended members for 2022-2023. This committee meets four times per year to assist the district in ensuring that local community values are reflected in the district's health education. The committee also develops a wellness plan for the district.

# SHAC REPORT

Tina Schmelzer, BSN, RN  
District Health Services Coordinator

# Core Membership - Parents

- Tina Baron - Parent
- Darren Calvert - Parent
- Carrie Calvert - Parent
- Carol Hatcher - Parent and SHAC CoChair
- Christina Carter - Parent
- Lisa Nickel - Parent and SHAC Secretary

Note: Per Board Policy BDF (LEGAL), a majority of members must be parents of students enrolled in the district and who are not employed by the district.

# Additional Core Membership - Employees

- Tina Schmelzer, BSN, R.N. - District Health Services Coordinator and SHAC Chair
- Tanya Stivors - District Safety Coordinator
- Ross Schonhoeft - District Child Nutrition Director

# Previous Years Activities

- Provided Education and Resources on Health Disparities in our County
- Provided Education and Resources on the New Adoption of Health Textbook-Goodheart and Willcox
- Awareness and Education on the McKinney Vento Act
- Awareness and Education on Mental Health Coping Techniques

# SHAC Webpage Contents

- Mission Statement
- Purpose / Goal
- 2020 Triennial Assessment, SHAC Bylaws, and Wellness Plan
  
- Meeting Information
  - Announcements
  - Agendas
  - Meeting Minutes

# Medina Valley Independent School District

## *Agenda Item Memorandum*

*To: MVISD Board of Trustees*

*Date: September 19, 2022*

*RE: Consider approving a resolution of Self-Certification of Increased Micro-Purchase Threshold*

The Code of Federal Regulations (2 CFR) §200.320, which is methods of federal procurement to be followed, officially sets the micro-purchase threshold at \$10,000 in the aggregate across all federal grant programs for the fiscal or grant year. It also allows the Local Educational Agency (LEA) to annually self-certify a higher micro-purchase threshold of up to \$50,000. This allows the grant purchases made with federal funds to be up to \$50,000 in the aggregate, thus mirroring our current purchasing guidelines.

## Medina Valley ISD

### Self-Certification of Increased Micro-Purchase Threshold

WHEREAS, Pursuant to Board Policy CH Local, the Board has authorized the Superintendent to develop purchasing procedures to implement the requirements of state and federal law. Further, the District's Board of Trustees have delegated authority to the Superintendent to make budgeted purchases of goods and services costing less than \$50,000.

WHEREAS, Pursuant to 2 CFR 200.320(a)(1)(iv), a non-Federal entity may self-certify a Micro Purchase Threshold **up to \$50,000** on an annual basis and must maintain documentation to be made available to the Federal awarding agency and auditors in accordance with 2 CFR 200.334.

WHEREAS, Pursuant to 2 CFR 200.320(a)(1)(iii), a non-Federal entity is responsible for determining and documenting an appropriate micro-purchase threshold based on internal controls, an evaluation of low-risk, and its documented procurement procedures.

WHEREAS, Pursuant to Texas Education Code (TEC) 44.031, all school district contracts for the purchase of goods and services, except for contracts for the purchase of produce or vehicle fuel, valued at **\$50,000 or more** in the aggregate for each 12-month period shall be made by the method that provides the best value for the district.

THEREFORE, Medina Valley ISD self-certifies that effective July 1, 2022 for fiscal year 2022-2023, its Micro Purchase Threshold, as defined in 2 CFR 200.320(a)(1)(ii), is hereby increased to **\$49,999**. Unless otherwise required by the District's internal purchasing regulations or controls, purchases up to the Micro Purchase Threshold may be purchased without soliciting competitive price or rate quotations if the District considers the price to be reasonable based on research, experience, purchase history or other information and documents it files accordingly.

This self-certification is based on the following justification, as recognized and authorized by 2 CFR 200.320(a)(1)(iv)(c):

Texas law generally permits public school districts to make non-competitive purchases for goods or services valued less than \$50,000 in the aggregate, as set forth in Texas Education Code 44.031(a).

In any instance where Texas or other federal law imposes a requirement to competitively procure any good or service costing less than \$50,000, or where Texas or other federal law imposes more stringent purchasing standards or procedures set forth in 2 CFR Part 200, the District shall follow the more restrictive legal requirement.

APPROVED BY:

---

Dr. Scott Caloss, Superintendent

Medina Valley ISD

Date: \_\_\_\_\_

# Medina Valley Independent School District

## *Agenda Item Memorandum*

*To: MVISD Board of Trustees*

*Date: 9-19-2022*

*RE: Consider approving purchase and installation of compressor for chiller at LaCoste Elementary*

The compressor for the HVAC Chiller at LaCoste Elementary went out a couple of weeks ago. The total cost for the replacement and installation of the compressor will be \$62,018.88.



# Proposal

JOHNSON CONTROLS SAN ANTONIO TX  
CB - 0N85  
3660 THOUSAND OAKS DR STE 216  
SAN ANTONIO TX 78247-3141  
PH: (866) 297 7794  
FAX:

**TO:** MEDINA VALLEY INDEPENDENT  
SCHOOL DIST  
8449 FM 471  
  
CASTORVILLE, TX 78009

**Date:** 9/1/2022

**Quote Ref:** 1-1JKJ28TO  
**Project Name:** Medina Valley ISD CH#1B New compressor  
**Site:** MEDINA VALLEY INDEPENDENT SCHOOL  
DIST  
8449 FM 471 S  
CASTROVILLE, TX 78009-5313

**ATTN:** KYLE SANDVIG

We propose to furnish the materials and/or perform the work below for the net price of: \$62,018.88

**For the above price this proposal includes:**

JCI to propose LO/TO unit, remove high voltage wiring, piping, transducers and foot mounts, remove defective compressor and replace with new compressor, re-attach all components and pressurize with nitrogen to ensure no other leaks are present, remove nitrogen, conduct a vacuum and charge circuit back with (170)lbs of R-134a freon provided by customer, re-energize unit and monitor overall operations.

THIS QUOTE IS FOR A NEW COMPRESSOR

COMPRESSOR LEAD TIME IS 4-6 WEEKS

**This proposal DOES NOT include:**

1. Labor or material not specifically described above is excluded from this proposal.
2. Unless otherwise stated, any and all overtime labor is excluded from this proposal.
3. Applicable taxes or special freight charges are excluded from this proposal.

**Important:** This proposal incorporates by reference the Terms and Conditions attached

This proposal is hereby accepted and Johnson Controls is authorized to proceed with the work, subject to credit approval by Johnson Controls, Inc. Milwaukee, WI.

This proposal is valid through: 10/1/2022

MEDINA VALLEY INDEPENDENT SCHOOL DIST

Johnson Controls

Signature: \_\_\_\_\_

Signature: \_\_\_\_\_

Name: \_\_\_\_\_

Name: \_\_\_\_\_

Title: \_\_\_\_\_

Title: \_\_\_\_\_

Date: \_\_\_\_\_

Date: \_\_\_\_\_

PO: \_\_\_\_\_

# Medina Valley Independent School District

## *Agenda Item Memorandum*

*To: MVISD Board of Trustees*

*Date: 9-19-2022*

*RE: Consider the purchase of three district vehicles*

The facilities department is requesting the purchase of three new vehicles to replace aging vehicles. These vehicles are 2023 Ford Mavericks, costing \$26,255.00 each.



# Rush Truck Center - Dallas Medium Duty

4000 Irving Boulevard  
Dallas, TX 75247  
214-631-2050

# Customer Proposal Letter

Internet Pricing Account  
4000 Irving Blvd  
Dallas, TX 75247

Thank you for trusting us with your business. Please review the proposal below, and if you approve, sign and return to us at your convenience. We look forward to working with you and will continue to do our best to earn your trust now and in the future.

### VEHICLE INFORMATION

Year 2023 Make Ford Model Maverick Stock # TBD Serial # TBD

Additional Vehicle Details: Pricing based on Buyboard Contract 601-19.

	Total
Quantity	
Truck Price per Unit	\$ 26,005.00
F.E.T. (Factory & Dealer Paid)	\$ 0.00
Net Sales Price	\$ 26,005.00
Optional Extended Warranty(ies)	
State Sales Tax	
Documentary Fee	\$ 250.00
Total Sales Price	\$ 26,255.00
Trade Allowance (see DISCLAIMER Below)	
Deposit / Down Payment	
Unpaid Balance Due on Delivery	\$ 26,255.00

Sales Representative	Signature _____	James Galbreath	Printed Name _____	Date _____
Purchaser	Signature _____		Printed Name / Title _____	Date _____
Accepted by Sales Manager or General Manager	Signature _____		Printed Name _____	Date _____

**Quote good until 10/15/2022** Note: The above Customer Proposal is a quotation only. Sale terms subject to approval of Sales Manager of Dealer.

DISCLAIMER: Any order based on this Proposal is subject to Customer executing Dealer's standard form Retail Sales Order and other required documents incorporating the above terms. Any documentary fees, FET, state tax, title, registration and license fees subject to adjustment and change. This Proposal is based upon Dealer's current and expected inventory, which is subject to change. Dealer is not obligated to retain any specific vehicles in stock, nor maintain specific inventory levels. Dealer shall not be obligated to fulfill Proposal in event quoted vehicle(s) is not in stock or available within requested delivery schedule. Manufacturer has reserved the right to change the price to Dealer of any vehicle not currently in Dealer's stock, without notice to Dealer and Dealer reserves the right to change Quotation Total to reflect any price increases from Manufacturer. Dealer shall not be liable for any delay in providing or inability to provide Quoted Vehicle(s). Above listed Trade Value based upon current appraisal of Trade Vehicle(s). Dealer may adjust Trade Value of Trade Vehicle(s) to reflect changes in condition and/or mileage of Trade Vehicle(s) between date of current appraisal and acceptance of the Trade Vehicle by Customer. 99

<sup>(1)</sup> Includes subscription period for # of specified months. <sup>(2)</sup> Customer's use of RushCare Service is governed by the RushCare User Agreement located at <https://www.rushtruckcenters.com/rushcare-user-agreement>. <sup>(3)</sup> Customer's use of Telematics Services is governed by separate 3<sup>rd</sup> party license terms and Rush is not liable for the Telematics Service. <sup>(4)</sup> Gap Coverage is provided and administered by an independent 3<sup>rd</sup> party provider under a separate contract directly between Customer and the 3<sup>rd</sup> party provider.

# Medina Valley Independent School District

## *Agenda Item Memorandum*

*To: MVISD Board of Trustees*

*Date: 9-19-2022*

*RE: Consider approving the purchase of up to six portables*

To accommodate our growing student populations specifically at Luckey Ranch Elementary and Potranco Elementary, we are seeking approval for the purchase of up to six new portables. The purchase and installation for each 24 x 64 portable building with restrooms and ducted HVAC will be \$120,700.00 (see quote for additional details). Two portables that are currently available will be purchased immediately with the remaining four to be ordered with the expected delivery date of early summer. Determination of location will be made based on student enrollment.



AMERICA'S LEADER IN

**DESIGN-BUILD**

MODULAR

CONSTRUCTION

September 15, 2022

Via e-mail: Brandon.Haby@mvisd.org

Mr. Brandon Haby  
Director of Facilities  
MEDINA VALLEY ISD  
8752 FM 471 S  
LaCoste, TX 78039

Re: Proposal Portable Classroom Building - MVISD Specification

Mr. Haby:

Ramtech appreciates your continued interest and the opportunity to provide you with a pricing proposal for portable classroom buildings. The BuyBoard price (contract #637-21) is based on new state approved commercial grade buildings constructed to Medina Valley ISD specifications.

**Purchase 24x64 double classrooms building with restrooms:**

Building with ducted HVAC: \$120,700.00 per bldg.

**Pricing Includes:**

- Delivery & Installation - Castroville, TX
- C.M.U. block pad on grade foundation
- Metal exterior and roof
- Lay-in acoustical ceiling
- Anchor type tie-downs (additional cost will be incurred for buildings set on concrete or asphalt due to anchoring requirements)
- Skirting to grade on all sides
- Gutters
- Interior walls to be vinyl covered gypsum panels
- Vct flooring
- Exterior wall hung HVAC - ducted
- Exterior emergency egress light above each exterior door shall be remote head wired into exit light
- Main Distribution Panel; 1 phase, indoor flush mount with 200 AMP main breaker
- Service to be 208/120
- 2 each future data outlet boxes n wall with double gang box 18" AFF with 3/4" conduit to above ceiling
- 1 each future thermostat outlet box in wall with single gang box 48" AFF with 1/2" conduit to above ceiling
- 1 each future fire alarm pull outlet box in wall with single gang box 48" AFF with 1/2"

conduit to above ceiling

Page 2 of 3- Proposal Portable Classroom Building - MVISD Specification

**Pricing Includes:**

- 1 each future intercom outlet box n wall with single gang box 8" AFF with 1/2" conduit to above ceiling
- 2x2 ceiling tiles
- Interior communication door
- Door closers all exterior doors
- Insulated windows
- Interior lights will be 2x4 lay-in LED fixtures - dual switched
- Marker - tack board each classroom
- State approved engineered drawings

**Pricing does not include:**

- Site preparation (including grading, compaction or demolition, landscaping or irrigation)
- Building permits (Any fees charged by the city or county agencies for the movement of mobile office or modular buildings over local roads are considered as part of the local building permit cost.) Building will not be constructed until owner has obtained the required building permit.
- Furniture, window coverings
- Canopies
- Entry assemblies
- Fire alarm/sprinkler system
- Performance and payment bond
- Permanent foundation
- Plumbing manifold
- Poured concrete
- Ramtech's Builders Risk Insurance excludes flood coverage in Flood Zones A, V, or D as defined by FEMA
- Taxes (if applicable)
- Utility extension/connections
- Waxing or sealing of vct
- Wind certification (if required)
- The scope of this design does not include accessibility elements required for the site. It is the owner's responsibility to have these designs developed and to make submittal as required by the Texas Architectural Barriers Act, through their design professional. This submittal should be made to: Texas Department of Licensing and Regulations, Architectural Barriers Section, P.O. Box 12157, Austin, TX 78711.



AMERICA'S LEADER IN  
**DESIGN-BUILD**  
MODULAR  
CONSTRUCTION

Page 3 of 3 - Proposal Portable Classroom Building - MVISD Specifications

I will contact you to discuss any questions you might have or please feel free to contact me via email at [squeen@ramtechgroup.com](mailto:squeen@ramtechgroup.com) or by calling 800-568-9376 ext. 145.

Sincerely,  
Sabrina Queen  
Education Representative

*Note: Given the volatility of material prices and supply chain challenges, Ramtech's price is valid for 14 days. Please contact Ramtech prior to issuance of a p.o. or award to verify pricing as well as open production availability*

**Pricing is based on a level, accessible site.**

**To provide our customers value, Ramtech has quoted the pricing reflected in this proposal as competitively as possible. As such, once we begin, we have anticipated an uninterrupted flow of our work through the completion of the project. Should non-weather-related events beyond Ramtech's control, such as delays in electrical or water service to the building, force us to demobilize and subsequently remobilize at a later date, additional costs will be incurred that may be passed on to our customers.**

**Typical payment terms are 25% upon issuance of a p.o. or execution of a contract, 70% prior to delivery and installation of the building(s) and 5% on completion and acceptance.**

# Medina Valley Independent School District

## *Agenda Item Memorandum*

*To: MVIDS Board of Trustees*

*Date: 9-19-2022*

*RE: Consider the purchase of five buses*

The Transportation Department is requesting the purchase of five new buses for expansion and replacement of fleet buses. These buses will have a/c and seatbelts, as previously purchased buses. Previous annual bus purchases have been filled within six months of the order date, currently bus purchases are taking a year to be filled. The expected delivery of these new buses will be during the 2023-2024 school year. The cost of each bus is \$124,657.00.



# **INTEGRATED CE S BUS**

Sales Proposal For:  
**Medina Valley ISD**

Presented By:  
**LONGHORN BUS SALES**

**Prepared For:**  
Medina Valley ISD  
TOBIE KENNEDY  
8449 F M 471 South  
Castroville, TX 78009-  
(830)931 - 2867  
Reference ID: 1 71P DSL 3PT

**Presented By:**  
LONGHORN BUS SALES  
FRED HOKE  
9100 N LOOP E  
HOUSTON TX 77029 -  
(713)631-9306

Thank you for the opportunity to provide you with the following quotation on a new IC Corporation vehicle. I am sure the following detailed specification will meet your operational requirements, and I look forward to serving your business needs.

**Model Profile**  
**2024 INTEGRATED CE S BUS (PB105)**

<b>APPLICATION:</b>	School Transportation
<b>MISSION:</b>	Requested GVWR: 31000. Calc. GVWR: 31000 Calc. Start / Grade Ability: 27.37% / 2.51% @ 55 MPH Calc. Geared Speed: 79.6 MPH
<b>DIMENSION:</b>	Wheelbase: 276.00, CA: N/A, Axle to Frame: 166.00
<b>ENGINE, DIESEL:</b>	{Cummins B6.7 260} EPA 2021, 260HP @ 2400 RPM, 660 lb-ft Torque @ 1600 RPM, 2600 RPM Governed Speed, 260 Peak HP (Max), School Bus Only
<b>TRANSMISSION, AUTOMATIC:</b>	{Allison 2500 PTS} 6th Generation Controls, Wide Ratio, 6-Speed with Double Overdrive, Less PTO Provision, Less Retarder, with 33,000-lb GVW and GCW Max, School Bus
<b>CLUTCH:</b>	Omit Item (Clutch & Control)
<b>AXLE, FRONT NON-DRIVING:</b>	{Meritor MFS-10-122A} I-Beam Type, 10,000-lb Capacity
<b>AXLE, REAR, SINGLE:</b>	{Dana Spicer S140} Single Reduction, 21,000-lb Capacity, 190 Wheel Ends Gear Ratio: 6.14
<b>TIRE, FRONT:</b>	(2) 11R22.5 Load Range H AH37 (HANKOOK), 499 rev/mile, 75 MPH, All-Position
<b>TIRE, REAR:</b>	(4) 11R22.5 Load Range H AH37 (HANKOOK), 499 rev/mile, 75 MPH, All-Position
<b>SUSPENSION, REAR, AIR, SINGLE:</b>	{International IROS} 21,000-lb Capacity, 9.25" Ride Height, with Shock Absorbers
<b>PAINT:</b>	Cab schematic 100NB Location 1: 4421, School Bus Yellow (Std) Chassis schematic N/A

**Vehicle Specifications**  
**2024 INTEGRATED CE S BUS (PB105)**

September 14, 2022

<b>Code</b>	<b>Description</b>
PB10500	Base Chassis, Model INTEGRATED CE S BUS with 276.00 Wheelbase, N/A CA, and 166.00 Axle to Frame.

**BODY PLANS**

---

47AMG	BODY, BUS Conventional; 78" Headroom, 34'11" Body Length, +9 Section Rear, 78 Passenger, 276 WB  <u>Includes</u> : NOTE: Body Mandates Overall Vehicle Length of Greater than 40 Feet
50UXN	BODY PLAN, NON-SPECIAL NEEDS Conventional; 34' 11" Body Length, +9 Section Rear, 71 Passenger, 276" WB, DX9714A000
49001	BODY PLAN, APPROVED VARIATION Number 001

**ENGINE**

---

12ERU	ENGINE, DIESEL {Cummins B6.7 260} EPA 2021, 260HP @ 2400 RPM, 660 lb-ft Torque @ 1600 RPM, 2600 RPM Governed Speed, 260 Peak HP (Max), School Bus Only
12XCS	CARB EMISSION WARR COMPLIANCE Federal, Does Not Comply with CARB Emission Warranty
12WZE	CARB IDLE COMPLIANCE Federal, Does Not Comply with California Clean Air Idle Regulations
12VJB	EMISSION, CALENDAR YEAR {Cummins B6.7} EPA, OBD and GHG Certified for Calendar Year 2022
12UYE	RADIATOR Aluminum, 2-Row, Cross Flow, Over Under System, 717 SqIn Louvered, with 313 SqIn Charge Air Cooler, Includes In-Tank Oil Cooler  <u>Includes</u> : DEAERATION SYSTEM with Surge Tank : HOSE CLAMPS, RADIATOR HOSES Gates Shrink Band Type; Thermoplastic Coolant Hose Clamps : RADIATOR HOSES Premium, Rubber
12TSY	FAN DRIVE {Borg-Warner SA85} Viscous Type, Screw On  <u>Includes</u> : FAN Nylon
12VBR	AIR CLEANER with Service Protection Element  <u>Includes</u> : GAUGE, AIR CLEANER RESTRICTION Air Cleaner Mounted
12703	ANTI-FREEZE Red, Extended Life Coolant; To -40 Degrees F/ -40 Degrees C, Freeze Protection
12VVN	CRUISE CONTROL Electronic  <u>Notes</u> : Cruise Control Switches Mounted on Steering Wheel are Non-Illuminated.
12WAK	ENGINE SOUND ABATEMENT PACKAGE Exterior, for International Engines with Underhood Blanket and Foam Covered Splash Shields
12VWH	GOVERNOR Electronic Road Speed Type; for Electronic Engines and Bus Models; with 55 MPH Default
12VYV	IDLE MANAGEMENT SYSTEM Ramp Engine Speed with Air Condition On, in Neutral and Parking Brake Set, Accommodation Package
12UGN	THROTTLE, HAND CONTROL Electronic  <u>Notes</u> : Cruise Control Switches Mounted on Steering Wheel are Non-Illuminated.

**TRANSMISSION**

---

**Vehicle Specifications**  
**2024 INTEGRATED CE S BUS (PB105)**

September 14, 2022

<b>Code</b>	<b>Description</b>
13BBP	TRANSMISSION, AUTOMATIC {Allison 2500 PTS} 6th Generation Controls, Wide Ratio, 6-Speed with Double Overdrive, Less PTO Provision, Less Retarder, with 33,000-lb GVW and GCW Max, School Bus
13WVW	NEUTRAL AT STOP OMIT
13WYY	SHIFT CONTROL PARAMETERS {Allison} 1000 or 2000 Series Transmissions, Performance Programming
13WLN	TRANSMISSION OIL Synthetic; 20 thru 28 Pints

**CLUTCH**

---

11001	CLUTCH Omit Item (Clutch & Control)
-------	-------------------------------------

**REAR AXLES, SUSPENSIONS**

---

14AKC	AXLE, REAR, SINGLE {Dana Spicer S140} Single Reduction, 21,000-lb Capacity, 190 Wheel Ends . Gear Ratio: 6.14
14TBS	SUSPENSION, REAR, AIR, SINGLE {International IROS} 21,000-lb Capacity, 9.25" Ride Height, with Shock Absorbers

Notes

: The following features should be considered when calculating Rear GAWR: Rear Axles; Rear Suspension; Brake System; Brakes, Rear Air Cam; Brake Shoes, Rear; Special Rating, GAWR; Wheels; Tires.

**FRONT AXLES**

---

2ASH	AXLE, FRONT NON-DRIVING {Meritor MFS-10-122A} I-Beam Type, 10,000-lb Capacity
------	---

Includes  
: AXLE, FRONT SQUARING to Plus or Minus .015 Inch, using a Special Fixture to Assure Parallelism of Springs

Notes  
: The following features should be considered when calculating Front GAWR: Front Axles; Front Suspension; Brake System; Brakes, Front Air Cam; Wheels; Tires.

**FRONT SUSPENSIONS**

---

3ADB	SUSPENSION, FRONT, SPRING Parabolic Taper Leaf, Shackle Type, 10,000-lb Capacity, with Shock Absorbers
------	--

Includes  
: SPRING PINS Bolt and Nut Type  
: SPRING PINS Rubber Bushings, Maintenance-Free

Notes  
: The following features should be considered when calculating Front GAWR: Front Axles; Front Suspension; Brake System; Brakes, Front Air Cam; Wheels; Tires.

**CABS, COWLS, BODIES**

---

16010	COWL Flat Back
16HBA	GAUGE CLUSTER English with English Electronic Speedometer

Includes  
: GAUGE CLUSTER (5) Engine Oil Pressure (Electronic), Water Temperature (Electronic), Fuel (Electronic), Tachometer (Electronic), Voltmeter  
: ODOMETER DISPLAY, Miles, Trip Miles, Engine Hours, Trip Hours, Fault Code Readout  
: WARNING SYSTEM Low Fuel, Low Oil Pressure, High Engine Coolant Temp, and Low Battery Voltage (Visual and Audible)

**Vehicle Specifications**  
**2024 INTEGRATED CE S BUS (PB105)**

September 14, 2022

<b><u>Code</u></b>	<b><u>Description</u></b>
16HLJ	GAUGE, DEF FLUID LEVEL
16HGH	GAUGE, OIL TEMP, AUTO TRANS for Allison Transmission
16HKT	IP CLUSTER DISPLAY On Board Diagnostics Display of Fault Codes in Gauge Cluster

**FRAMES**

---

1CAC	FRAME RAILS High Strength Low Alloy Steel (50,000 PSI Yield); 10.125" x 3.062" x 0.312" (257.2mm x 77.8mm x 8.0mm); 489.2" (12425mm) Maximum OAL  <u>Includes</u> : CHASSIS PAINT Chassis Painted Prior to Body Mounting : FRAME RAILS All holes Laser Aligned and Machine Punched, Powder Coated Prior to Full Assembly, Assembled in Fixture using "Grade 8" Bolts : FRAME REINFORCEMENT, SPECIAL 3.30" x 1.80" x 0.312" x 31.50" Inverted "L" in Front Shock Absorber Mounting Area
1LTV	BUMPER, FRONT Contoured, Steel, Heavy Duty
1LNW	CROSSING GATE, FRONT Air, Yellow Blade, Bumper Mounted  <u>Includes</u> : CONTROL ASSEMBLY Located Rear of Front Bumper, Heater not Required : CROSSING GATE, FRONT Matches Contour of Bumper
1SAM	CROSSMEMBER, REAR, AF (2)
1WJE	WHEELBASE RANGE 276" (700cm) Only

**BRAKES**

---

4091	BRAKE SYSTEM, AIR Dual System for Straight Truck Applications  <u>Includes</u> : BRAKE LINES Color and Size Coded Nylon : DRAIN VALVE Twist-Type : GAUGE, AIR PRESSURE (2) Air 1 and Air 2 Gauges; Located in Instrument Cluster : PARKING BRAKE CONTROL Yellow Knob, Located on Instrument Panel : PARKING BRAKE VALVE For Truck : QUICK RELEASE VALVE On Rear Axle for Spring Brake Release: 1 for 4x2, 2 for 6x4 : SPRING BRAKE MODULATOR VALVE R-7 for 4x2, SR-7 with relay valve for 6x4/8x6  <u>Notes</u> : Rear Axle is Limited to 19,000-LB GAWR with Code 04091 BRAKE SYSTEM, AIR and Code 04NDC BRAKES, REAR, AIR CAM Regardless of Axle/Suspension Ordered : Rear Axle is Limited to 20,000-LB GAWR with Code 04092 BRAKE SYSTEM, AIR and Code 04NCW BRAKES, REAR, AIR CAM Regardless of Axle/Suspension Ordered
4GBM	BRAKE, PARKING Manual Push-Pull Pneumatic Parking Brake
4AZS	AIR BRAKE ABS {Bendix AntiLock Brake System} 4-Channel (4 Sensor/4 Modulator) Electronic Stability Program, with Automatic Traction Control
4XDP	BRAKES, FRONT {Meritor 16.5X5 Q-PLUS CAST} Air S-Cam Type, Cast Spider, Fabricated Shoe, Double Anchor Pin, Size 16.5" X 5", 14,700-lb Capacity
4EXP	BRAKE CHAMBERS, FRONT AXLE {Bendix} 20 Sqli
4LAG	SLACK ADJUSTERS, FRONT {Gunite} Automatic
4XDR	BRAKES, REAR {Meritor 16.5X7 Q-PLUS CAST} Air S-Cam Type, Cast Spider, Fabricated Shoe, Double Anchor Pin, Size 16.5" X 7", 23,000-lb Capacity per Axle

**Vehicle Specifications**  
**2024 INTEGRATED CE S BUS (PB105)**

September 14, 2022

<b>Code</b>	<b>Description</b>
4EXU	BRAKE CHAMBERS, REAR AXLE {Bendix EverSure} 30/30 SqIn Spring Brake
4SPA	AIR COMPRESSOR {Cummins} 18.7 CFM
4EBS	AIR DRYER {Bendix AD-9} with Heater
4VCY	AIR TANK LOCATION (1) Mounted Left Side to Provide Clearance for Larger Body Builder Supplied Battery Box
4722	DRAIN VALVE {Bendix DV-2} Automatic, with Heater, for Air Tank
4WZT	GVWR LIMITATION FOR BUS with Air Brakes, Limited to 33,000-lbs Maximum to meet FMVSS 121 Requirements, for Conventional Bus
4LGG	SLACK ADJUSTERS, REAR {Gunite} Automatic

**STEERING**

---

5PSA	STEERING GEAR {Sheppard M100} Power
5708	STEERING COLUMN Tilting
5CAL	STEERING WHEEL 2-Spoke, 18" Dia., Black

**DRIVELINES**

---

6DGA	DRIVELINE SYSTEM {Dana Spicer} SPL100, for 4x2/6x2
------	--

**EXHAUST SYSTEMS**

---

7BMK	EXHAUST SYSTEM Horizontal Aftertreatment System, Frame Mounted Under Right Rail, for Single Long Horizontal Tail Pipe
7SCP	ENGINE EXHAUST BRAKE for Cummins ISB/B6.7/ISL/L9 Engine with Variable Vane Turbo Charger
7WCX	HEAT SHIELD Between Exhaust & Fuel Tank, Mounted to AF Crossmember
7WBL	TAIL PIPE (1) Horizontal, Long, Exits Left Side Through Bumper

**ELECTRICAL SYSTEMS**

---

8000	ELECTRICAL SYSTEM 12-Volt, Standard Equipment  <u>Includes</u> : HAZARD SWITCH Push On/Push Off, Located on Top of Steering Column Cover : HEADLIGHT DIMMER SWITCH Integral with Turn Signal Lever : MISCELLANEOUS FEATURES Modular, Loom Protected, Grommets in all Applicable Body Openings, Assembled in Computer Assisted Fixture which Verifies Continuity and Correct Assembly Prior to Installation : PARKING LIGHT Integral with Front Turn Signal and Rear Tail Light : STARTER SWITCH Electric, Key Operated : TURN SIGNAL FLASHER : TURN SIGNAL SWITCH Self-Cancelling with Lane Change Feature : TURN SIGNALS, FRONT Includes Reflectors; Flush Mounted : WINDSHIELD WIPER SWITCH 2-Speed with Wash and Intermittent Feature (5 Pre-Set Delays), Integral with Turn Signal Lever : WIRING, CHASSIS Color Coded and Continuously Numbered
8GXK	ALTERNATOR {Leece-Neville BLP4006HN} Brushless, 12 Volt, 325 Amp Capacity, Pad Mount, with Remote Sense
8TTK	BATTERY BOX Steel, with Sliding Tray, 25.25" Wide, for Standard Batteries, 1-3 Battery Capacity, Mounted Left Side Behind Front Axle Perpendicular to Frame Rail

**Vehicle Specifications**  
**2024 INTEGRATED CE S BUS (PB105)**

September 14, 2022

<b>Code</b>	<b>Description</b>
8NBX	BATTERY SYSTEM {JCI} Maintenance-Free, (3) 12-Volt 2850CCA Total, Top Threaded Stud
8XAH	CIRCUIT BREAKERS Manual-Reset (Main Panel) SAE Type III with Trip Indicators, Replaces All Fuses
8TPL	COLLISION MITIGATION SYSTEM {Bendix Wingman Advanced} Adaptive Cruise Control with Collision Mitigation and Stationary Object Alert; Includes Front Radar, Driver Display
8WXB	HEADLIGHT WARNING BUZZER Sounds When Head Light Switch is on and Ignition Switch is in "Off" Position
8WPB	HEADLIGHTS Halogen, Composite Aero Design, with Daytime Running Lights
8VBC	HORN, ELECTRIC (2) Trumpet Style, Mounted Above Left Frame Rail
8WWJ	INDICATOR, LOW COOLANT LEVEL with Audible Alarm
8XKL	STARTING MOTOR {Mitsubishi Electric Automotive America 90P47} 12-Volt, with Soft-Start

**FRONT END**

---

9WAY	FRONT END Tilting, Fiberglass, with Three Piece Construction  <u>Includes</u> : AIR INTAKE SYSTEM Integrated Pre-Cleaning System to Enhance Air Filter Life : GRILLE Removable; Fiberglass Painted Hood Color : SPLASH SHIELD Integral with Front End Assembly
9WAB	HOOD TILT ASSIST {EASY TILT} Mechanical
9AAE	LOGOS EXTERIOR, ENGINE Badges

**SPEEDOMETER, TOOLS, MISC**

---

10020	CHASSIS PAINT Full Chassis
10060	PAINT SCHEMATIC, PT-1 Single Color, Design 100  <u>Includes</u> : PAINT SCHEMATIC ID LETTERS "NB"
10788	PAINT TYPE Urethane, One or Two Colors, Other than Imron or International.
10XAK	PROMOTIONAL PACKAGE 7 Year Unlimited Miles/km Warranty, Limited Time Program for Allison 2500 Series Transmission on School and Commercial Buses (Supplied directly through Allison)
10XAJ	PROMOTIONAL PACKAGE LED EXT {Sound Off/OptiLuxx} LED Lights

**FUEL TANKS**

---

15SJT	FUEL TANK Top Draw, Steel, Rectangular, 100 US Gal (379L), Includes Protective Cage, with Low Profile Fuel Filler Assembly and Vent Hosing, Mounted Between Frame Rails and Behind Rear Axle
15WEP	DEF TANK 16.5 US Gal (62.5L) Capacity, Frame Mounted Outside Right Rail, Behind 0 Bow

**WHEELS, TIRES - FRONT**

---

27DUW	WHEELS, FRONT {Accuride 51408} DISC; 22.5x8.25 Rims, Powder Coat Steel, 2-Hand Hole, 10-Stud, 285.75mm BC, Hub-Piloted, Flanged Nut, with Steel Hubs
7382135809	(2) TIRE, FRONT 11R22.5 Load Range H AH37 (HANKOOK), 499 rev/mile, 75 MPH, All-Position

**WHEELS, TIRES - REAR**

---

28DUW	WHEELS, REAR {Accuride 51408} DUAL DISC; 22.5x8.25 Rims, Powder Coat Steel, 2-Hand Hole, 10-Stud, 285.75mm BC, Hub-Piloted, Flanged Nut, with Steel Hubs
-------	--

**Vehicle Specifications**  
**2024 INTEGRATED CE S BUS (PB105)**

September 14, 2022

<u>Code</u>	<u>Description</u>
7382135809	(4) TIRE, REAR 11R22.5 Load Range H AH37 (HANKOOK), 499 rev/mile, 75 MPH, All-Position

**WHEELS, SPARE**

---

26DUW	WHEEL, SPARE, DISC {Accuride 51408} 22.5x8.25 Rims, Powder Coat Steel, 10-Stud, 285.75mm BC, Hub-Piloted
-------	--

**BODY FEATURES**

---

47BAK	BUMPER, REAR Painted, 12" High, 3/16" Thick
47BAR	SUPPORTS, REAR BUMPER Bolted to Frame
47AYB	BODY, REAR Includes Emergency Door  <u>Includes</u> : DOOR, REAR EMERGENCY with Concealed Hinges : HEADER BUMPER Padded, Mounted Over Rear Door; Upholstered to Match Passenger Seat Color
47ARH	BOWS, ROOF 14 ga., One Piece Construction  <u>Includes</u> : BOWS, ROOF Positioned Floor Line to Floor Line, Threaded Through Roof Strainers and Drip Rail
47AMA	FASTENERS, EXTERIOR MOUNTED Stainless Steel Screws; for Fender and Body Exterior Rear View Mirrors, Bumper Mounted Crossing Gate and Body Mounted Stop Arm
47DXG	FASTENERS, HANDRAIL Plusnuts & Screws
47APX	FASTENERS, HEADLINER Screws
47AZL	FLOOR, BODY with Wheel Wells
47PBZ	HANDLE, ASSIST Windshield Side Mounted, Left and Right, Body Color
47APR	HEADLINER, BODY Conventional; 25'11"-35'08" Body Length, Perforated Full Length with Sound Insulation Full Length
47ARP	LIGHT BARS Plastic
47BBH	LINING, SIDE INTERIOR, LOWER Embossed Steel, Clear Coated
47AXT	RUB RAILS, BODY (4) Conventional; Steel, 31'2", 31'11", 32'8", 33'5", 34'2", 34'11", 35'8" Body Lengths, Includes Snow Rail  <u>Includes</u> : RUB RAILS Full Length, Primer Coated (Both Sides), Attached to Body without Cuts or Splices
47BBZ	SEALER Extra; Sidewall to Floor, In Wheel Pocket Area, and Rear Wall to Floor
47AZE	SIDE SHEET, BODY, EXTERIOR Conventional, 16ga., Smooth, 31'2", 31'11", 32'8", 33'5", 34'2", 34'11", 35'8" Body Lengths
47ASG	SKIRT, BODY for Conventional, 14 1/2", 16ga  <u>Includes</u> : SKIRT, BODY Extra Smooth Steel Supported by Floor Gussets
47AJW	STEP, FRONT ENTRANCE DOOR 27 1/4" Depth; 14ga Steel  <u>Includes</u> : STEP, FRONT ENTRANCE DOOR OPENING, 35 Inch Width; Continuous Bottom to Top
47AUR	TIE DOWNS, BODY Grade 8 Bolts, Every Body Section  <u>Includes</u>

**Vehicle Specifications**  
**2024 INTEGRATED CE S BUS (PB105)**

September 14, 2022

<b><u>Code</u></b>	<b><u>Description</u></b>
	: TIE DOWNS, BODY with Formed Tab that Fits into Floor Structure to Prevent Turning
47DAJ	COVER, REAR DOOR INSIDE HANDLE Partial Coverage
47DBP	DOOR, ENTRANCE, FRONT Air, Outward Opening, with Split Pane Glass
47DAK	FASTENERS, REAR DOOR Bolts and Nutserts, Rear Door To Body
47DDE	HANDLE, ASSIST, ENTRANCE DOOR Outside Entrance
47DEY	HANDLE, EXTERIOR, REAR Emergency Door; Yellow
47DDH	HOLD BACK, REAR DOOR Stationary, No Cables, with Plastic Cover
47DDU	LATCH, REAR DOOR One Point Slide Bar, Cam Operated, with One Inch Stroke
47EXK	LOCK, ENTRANCE DOOR Integrated Manual Control in Door, with Key
47DEK	LOCK, REAR DOOR with Ignition Starter Interlock
47EHA	CARTON, SHIPPING Carton for Spare Wheel Only, Inside Bus
47EBM	HOLD DOWN, BATTERY For (2) Standard Size Batteries
47LAU	INSULATION, ROOF/SIDES/BULKHEAD 1.5"
47MBC	INSULATION, STEPWELL
47LAT	NOISE REDUCTION, ROOF BOW Conventional; Insulation, 31'2", 31'11", 32'8", 33'5", 34'2", 34'11", 35'8" Body Lengths
47MBA	UNDERCOAT, BODY Fire Resistant, Water Based, TT-C-730 Spec
	<u>Includes</u>
	: UNDERCOATING Performed Before and After Mounting on Chassis
47SPC	ALPHA/NUMERIC DECAL GUIDE Quantity 031-40
47MNT	ARROW, RR DOOR, INSIDE Decal; Red, .75" Stroke, Indicating Handle Direction
47MNV	ARROW, RR DOOR, OUTSIDE Decal; Black .75" Stroke, Indicating Handle Direction
47AJA	BODY CERTIFICATION TAG Metal
47APJ	BODY RATING TAG Metal; for State of Texas, Includes Design Capacity and Seat Capacity
47AJC	BODY TAG, METAL Capacity to Include the Total Number of Passengers
47PLY	LETTERS, DEF, I.D. Paint; "DEF ONLY", 1" Black, on DEF Filler Door
47MJR	LETTERS, DOOR, REAR Decals; "EMERGENCY DOOR", 2" Black Letters Inside and Outside
47NGP	LETTERS, FUEL I.D. Paint; "DIESEL FUEL", 2" Black, Adjacent to Fuel Filler Door
47MVA	LETTERS, HEADER Decal; "WATCH YOUR STEP", 1" Black, Above Windshield
47MRU	LETTERS, E/E WINDOW, LEFT (2) Decal Sets, "EMERGENCY EXIT", Black Inside and Outside
47NHL	LETTERS, E/E WINDOW, RIGHT (2) Decal Sets, "EMERGENCY EXIT", Black, Inside and Outside
47MAV	LETTERS, SCHOOL BUS SIDE Decal; "SCHOOL BUS"; in 8" Reflective Black Letters, Each Side
47BKK	LETTERS, SCHOOL BUS FRONT/REAR Decal; "SCHOOL BUS"; with 8" Black Reflective Letters, 3M Fluorescent Diamond Grade, Yellow On Front and Rear Cap
47MVC	LETTERS, STEPWELL Decal, "WATCH YOUR STEP", 2.5" Black, Behind Door on Step Riser
47NTE	LOGO, ROOF LINE Decal; Wing and Shield, First Body Section, Above Driver Window and Entrance Door Over Driver Window and Entrance Door

**Vehicle Specifications**  
**2024 INTEGRATED CE S BUS (PB105)**

September 14, 2022

<b>Code</b>	<b>Description</b>
47NMG	OPERATING INSTR, REAR Decal, Inside Rear Emergency Door
47NJA	PAINT COLOR, BODY EXTERIOR 4421 School Bus Yellow
47NKM	PAINT COLOR, BODY INTERIOR 9384 Spring White
47NJS	PAINT COLOR, BUMPER Rear, 0001 Canyon Black
47NKD	PAINT COLOR, ROOF 9219 Winter White, Beginning 5" Above Drip
47NAB	PAINT COLOR, RUB RAILS 0001 Canyon Black
47NJM	PAINT FLASHER BACKGRD 0001 Canyon Black
47NTY	PAINT HOOD AND FENDER To Match Body Exterior
47NKL	PAINT, RUB RAIL Flange to Flange
47NGW	SEAL, RUB RAILS Top Edge, All Rails
47NXH	STRIPING, E/E WINDOW, LEFT {3M} (02) Perimeter, 1" Yellow Fluorescent Diamond Grade
47NWU	STRIPING, E/E WINDOW, RIGHT {3M} (02) Perimeter, 1" Yellow Fluorescent Diamond Grade
47NXN	STRIPING, PERIMETER, REAR {3M} Emergency Door, 1" Yellow Fluorescent Diamond Grade
47NWR	STRIPING, REAR END {3M} 2" Yellow Fluorescent Diamond Grade
47NWT	STRIPING, ROOF HATCH, FRONT {3M} Decal, Perimeter, 1" Yellow Fluorescent Diamond Grade
47NWH	STRIPING, ROOF HATCH, REAR {3M} Decal, Perimeter, 1" Yellow Fluorescent Diamond Grade
47NWJ	STRIPING, SEATLINE {3M} 2" Yellow Fluorescent Diamond Grade
47MTY	WIRING DIAGRAM Schematic, Electrical
	<u>Includes</u> : ACCESS PANEL for Wiring Diagram Schematic Located on Body Exterior; Below Driver Window
47SBB	SUB FLOOR, PLYWOOD Conventional; B-B Marine Grade, Less Sealed Edges, 5/8", 5 Ply, for 31'2", 31'11", 32'8", 33'5", 34'2", 34'11", 35'8" Body Lengths
47KDC	MONITOR, POST TRIP INSPECTION {Leave No Student Behind} Accessory Controlled, with Push Button Alarm Disable at Rear of Bus in Light Bar Prompts Driver to Walk to Back of Bus to Disable Alarm
47DNK	SWITCH, LOCATION Steering Wheel; Includes Master Flasher, Flasher On/Off, Red Override, and Door Control
	<u>Includes</u> : SWITCH, STEERING WHEEL, LIGHT Includes Illuminated Switches

**BODY FEATURES**

---

48ANT	WINDOW, DRIVER Laminated, Clear
48ANM	WINDOW, ENTRANCE DOOR, BOTTOM Laminated, Clear
48ANE	WINDOW, ENTRANCE DOOR, TOP Laminated, Clear
48BJA	COLOR, WINDOW FRAME, PASS Passenger Window, Natural Aluminum Finish
48BAH	WINDOW, E/E, LEFT (2) Vertical Hinge
48BKP	WINDOW, E/E, RIGHT (2) Vertical Hinge
48AUN	WINDOW, PASSENGER, TINT Conventional; 28% Light, Laminated Glass, 78" Headroom, with 31'2", 31'11", 32'8", 33'5", 34'2", 34'11", 35'8" Body Lengths

**Vehicle Specifications**  
**2024 INTEGRATED CE S BUS (PB105)**

September 14, 2022

<b>Code</b>	<b>Description</b>
48ARU	WINDOW, SASH (20) 27" Sections, 9"x 23" Opening
48ASP	WINDOW, SASH +9 SECTIONS (2) 9" x 32 1/4" Opening
48APL	WINDOW, STOPS 12" Opening, Only with 78" Headroom
48PAM	WINDSHIELD 3 Flat Pieces, 73% Light, with Band
48PAY	AISLE POSITION Center, for balanced seating
48PBB	FLOOR COVERING, COLOR Black
48PJR	FLOOR COVERING, TRIM Aluminum
48PJZ	FLOOR COVERING, TYPE {Koroseal} All Body Lengths
48RZJ	STEP TREADS {Koroseal} Pebble Top with White Nosing, with Non-Metal Backing
48PAV	WHEEL POCKET COVER Plastic, ABS
48PKC	HOSE CLAMPS, HEATER HOSE Constant Torque for Heater System
48RDL	FAN, DEFOG LEFT OF DRIVER 6.50" Diameter, Black, Mounted Left of Driver Above Windshield, 2 Speed Switch in Panel
48PKS	FAN, DEFOG RIGHT CENTER 6.50" Diameter, Black, Mounted Over Windshield, 15" Right of Centerline, 2-Speed Switch in Panel
48PPM	HEATER CUT OFF, VALVE Ball, with Butterfly Handle
48PPP	HEATER CUT OFF, VALVE INSIDE Brass Ball, Inside Driver Area
48GYV	HEATER, DEFLECTOR Kit, for Driver Heater
48GHC	HEATER, DRIVER 90,000 BTU, with Defroster and without Rear Heat Duct
	<u>Includes</u> : AIR FILTER : HEATER HOSES Premium : HOSE CLAMPS, HEATER HOSE Mubea Constant Tension Clamps
48PMJ	HEATER, PASS, LT REAR 84,500 BTU
	<u>Includes</u> : AIR FILTER
48PNW	HEATER, WATER PUMP {2 MPU 12} Self Priming, with Plastic Housing
48UZN	ROOF HATCH, FRONT {Specialty Hybrid Adv H1975-025-191-0F} Emergency Exit with Outside Release, Alarm, English Decals
48UZT	ROOF HATCH, REAR {Specialty Hybrid Adv H1975-025-191-0F} Emergency Exit with Outside Release, Alarm, English Decals
48PPS	ROOF VENT, FRONT Static
48PPC	SWITCH, HTR FAN, REAR, LT with 84,500 BTU Rear Heater Only
48NAT	FITTINGS, AIR SEAT for Driver Seat
48PUT	NUTS, BELT MOUNTING Standard Nuts For Seat Belt Mounting
48RYW	SEAT, DRIVER {National 2000} Air Suspension, High Back with Integral Headrest, Isolated, with 2 Position Front Cushion Adjustment, 6 to 17 Degree Seat Back Adjustment, Mechanical Lumbar Support, Includes Additional Back Padding
	<u>Includes</u> : SEAT BELT, DRIVER Adjustable D-Loop Seat Belt, Single Locking Retractor

**Vehicle Specifications**  
**2024 INTEGRATED CE S BUS (PB105)**

September 14, 2022

<b>Code</b>	<b>Description</b>
48PXP	UPHOLSTERY, BARRIER, TYPE (1-2) Prevaill, 42 oz.
48PVN	UPHOLSTERY, DRIVER SEAT, COLOR Drivers Seat, Gray
48PVA	UPHOLSTERY, DRIVER SEAT, STYLE Plain, with Cloth Insert
48PWR	UPHOLSTERY, DRIVER SEAT, TYPE Prevaill, 42 oz.
48RAE	BARRIER, CRASH, AFT ENTRY DOOR 39", 1 Leg
48RAL	BARRIER, CRASH, AFT DRIVER 39", 1 Leg
48RGR	HAND RAIL, ENTRANCE DOOR, AFT Stainless Steel, 4", Above Step
48RGE	HAND RAIL, ENTRANCE DOOR, FWD Stainless Steel; Curved
48RET	PANEL, MODESTY, AFT ENTR DOOR Mounted Under Barrier
48REP	PANEL, MODESTY, AFT OF DRIVER Mounted Under Barrier
48ACN	SEAT BELT, DRIVER, COLOR with Blaze Orange Seat Belt Webbing
48USV	SEAT BACK, PASSENGER High Back
48XGC	SEAT,PASS,3PT,LT,26",2 LEG {BTI Seating System} (01) High Back, with 3 Point Seat Belts
48YAG	SEAT,PASS,3PT,LT,39",2 LEG {BTI Seating System} (11) High Back, with 3 Point Seat Belts
48YAW	SEAT,PASS,3PT,RT,39",2 LEG {BTI Seating System} (12) High Back, with 3 Point Seat Belts
48PWD	UPHOLSTERY, PASS SEATS, COLOR Gray, for Seats, Barriers and Head Bumpers
48PHP	UPHOLSTERY, PASS SEATS, TYPE Prevaill, 42 oz.; for (23-24) Seats
48RLX	CUSHION, SEAT 15" Depth
	<u>Includes</u> : WARRANTY Four Years
48RRA	UPHOLSTERY, SEAT, STITCHING Single
	<u>Includes</u> : WARRANTY Two Years

**BODY FEATURES**

---

49AMJ	ALARM, BACKING {Ecco #575} 107 dB
49AMT	CIRCUIT, PROTECTION Breakers, Manual Reset in Lieu of Fuses
	<u>Includes</u> : ACCESS PANEL for Body and Chassis Fuses/Circuit Breakers Located on Body Exterior; Below Driver Window
49AJH	CONNECTION, LIGHTS Cluster, Clearance and Side Marker To Tail Lights
49BCN	FLASHER SYSTEM (8) Warning Lights, 8-Lamp System, Electronic Relay Flasher, Non-Sequential Operation, Red Lights Activate with Door Open
49DBR	HOOD, WARNING LAMP (4) Black, 8-Lamp System, One Hood Above Two Lights
49APT	LIGHT, DRIVER Mounted in Wiring Access Panel in Ceiling in Light Bar, Left of Driver, Switch Located in Switch Panel
49JBU	LIGHT, ENTRY DOOR {Sound Off/OptiLuxx} LED; 4" Oval; Light Mounted in Skirt Behind Entrance Door, Wired To Step Light
49BCR	LIGHT, EXTERIOR, CHECK Automatically Activates Lights for Pre Trip Inspection

**Vehicle Specifications**  
**2024 INTEGRATED CE S BUS (PB105)**

**September 14, 2022**

<b>Code</b>	<b>Description</b>
49ATV	LIGHT, INDIC, WARNING LIGHTS Red and Amber  <u>Includes</u> : LIGHTS, WARNING Indicator Located in Instrument Cluster
49JBV	LIGHT, LICENSE PLATE {Sound Off/OptiLuxx} LED, with Mounting Gasket
49JBW	LIGHT, STEP {Sound Off/OptiLuxx} 4" Round LED, White, Wired to Clearance Lights, Operated by Entrance Door
49EYH	LIGHT, STROBE LED, Specialty Man. Co. 845-4020-100, Low Profile, Double Flash, 4.50" High
49AHV	LIGHT, STROBE, STOP SIGN, FRT In Lieu Of Flashing Lights Furnished with Stop Sign, Speciality
49AHY	LIGHT, STROBE, STOP SIGN, REAR In Lieu of the two Flashing Lights Furnished with Stop Sign, Speciality
49ZNC	LIGHTS, BACK UP (2) {Sound Off/OptiLuxx} 4" Round, White, LED, with Flange
49JBS	LIGHTS, CLUSTER {Sound Off/OptiLuxx} Oval, 4 Internal LEDs per Light; Amber Front and Red Rear
49BYZ	LIGHTS, DIRECTIONAL, REAR (2) {Sound Off/OptiLuxx} LED, 7" Round Amber
49EAX	LIGHTS, DIRECTIONAL, SIDE (4) {Sound Off/OptiLuxx} Rectangular LED Armored, 2 Each Side First Section Aft Entrance Door & Forward Rear Wheel Pocket
49APZ	LIGHTS, DOME Conventional, Rectangular Recessed Type, Two Full Rows, for 31'2", 31'11", 32'8", 33'5", 34'2", 34'11", 35'8" Body Lengths  <u>Includes</u> : WIRING HARNESS Main Body Wiring Harness Accessed by Removing Dome Light
49BYV	LIGHTS, MARKER, FRONT & REAR (8) {Sound Off/OptiLuxx} LED, Rectangular, Armored, (4) Amber Front and (4) Red Rear
49EAW	LIGHTS, MARKER, SIDE, INTERMED {Sound Off/OptiLuxx} LED, Amber, Rectangular, Armored, Intermediate, Centered, Required for Units 30 Foot or Longer
49BYT	LIGHTS, STOP (2) {Sound Off/OptiLuxx} and Tail; 7" Round LED, Red
49ZNG	LIGHTS, STOP & TAIL ADDITIONAL (2) {Sound Off/OptiLuxx} 4" Round LED, Red, with Flange
49NGJ	LIGHTS, WARNING (8) {Sound Off/OptiLuxx} (4) 7" Round Red Strobing LED and (4) 7" Round Amber Strobing LED, 2 Front, 2 Rear Each Color
49CLM	RADIO, ENTERTAINMENT AM/FM/USB Input/Auxiliary Input, Includes Antenna and Cable, with Public Address System
49ANU	SOURCE, POWER 12 VDC, Mounted In Dash
49AWU	SPEAKERS AND WIRING (6) Flush Mounted in Light Bar
49ELC	STOP ARM, FRONT Electric, Composite Blade, 18" Octagon, Double Sided, 1/2" White Border, Hi Intensity Grade, Strobing LED Lights
49ELG	STOP ARM, LEFT REAR Electric, Composite Blade, 18" Octagon, Single Sided, 1/2" White Border, Hi Intensity Grade, Strobing LED Lights
49AMD	SWITCH, DRIVER PANEL, TYPE Rocker
49SAA	SWITCH, INSTRUMENT PANEL LIGHTS; Rheostat
49ANH	SWITCH, MAGNETIC, DISCONNECT Master, Ignition Operated, All Body Circuits
49EVL	SWITCH, NOISE SUPPRESSION Actuator Legend States, "NOISE SUPP ", for Separate Solenoid, with Red Switch in Panel
49AMY	SWITCH, REAR DOOR BUZZER for Emergency Door

**Vehicle Specifications**  
**2024 INTEGRATED CE S BUS (PB105)**

**September 14, 2022**

<b>Code</b>	<b>Description</b>
49BXN	SWITCH, RED, OVERRIDE WARNING Wired Hot, with ESC, Mounted Left of Driver
49HES	MIRROR, BRACE, EXTERIOR Telescoping for Breakaway Bracket
49EGL	MIRROR, CROSS VIEW, EXTERIOR (2) {Rosco Mini Hawk-Eye} Black  <u>Includes</u> : MIRROR MOUNT Attached to Body with Metal Backing Plates
49EGB	MIRROR, INSIDE 10" x 30", Clear
49EJR	MIRROR, REAR VIEW, EXTERIOR {Rosco} Black, Motorized Head, Breakaway Bracket, Suspended
49ENK	VISOR, INTERIOR, LEFT FRONT 6" x 30", Transparent, For Left Windshield
49GDS	COMPARTMENT ABOVE DRIVER Left of the Driver  <u>Includes</u> : COMPARTMENT ABOVE DRIVER Compartment Size: 39" x 10" x 10" : HINGES Piano Type
49GGE	FIRE EXTINGUISHER, DRIVER AREA 5 lb 2A-40BC Minimum, with Flexible Hose and Metal Nozzle
49GAY	KIT, BODY FLUID Texas
49EBA	KIT, FIRST AID Plastic; 24 Unit, Spec State
49MZV	LATCH, COMPARTMENT Locking, for Overhead Storage Compartment
49GDG	PADDING COMPART ABOVE DRIVER Window; Safety Equipment Compartment, with Cutout for Dome Light
49GLP	REFLECTORS, REAR (2) 3", Red, Mounted with Screws
49GLM	REFLECTORS, SIDE, FRONT (2) 3", Amber; 1 Aft Drivers Window Left, 1 Aft Entrance Door Right, Mounted with Screws
49GLA	REFLECTORS, SIDE, INTERMEDIATE (2) 3" Amber, 1 Each Side, Mounted with Screws, Below The Third Rub Rail From the Top
49GLG	REFLECTORS, SIDE, REAR (2) 3", Red, Mounted with Screws
49GEH	SAFETY TRIANGLES Warning Reflectors, Mounted on Drivers Barrier 9.5" Above Floor
49GUB	CUTTER, SEAT BELT {TIE TECH Safecut} for Cutting Seat Belts
49GCC	CUTTER, SEAT BELT, LOCATION Centered on Inside of Driver Compartment Lid
49JAC	DEF FILLER DOOR with Non-Locking Latch
49MZS	FUEL FILLER DOOR Non-Locking, Lever Latch, Spring Loaded to Hold in Open Position
49CKT	FUEL FILLER PIPE Low Profile Neck Cap and Vent Hosing, for Use with Right Side Fill for Between the Rail Fuel Tanks, for Above the Floor Fuel Fill, for 25 GPM Fill Rate Only
49GUM	INSPECTION PLATE Fuel Sending Unit 8" x 8" Steel
49GUX	MUD FLAPS, FRONT WHEELS (2) Rubber
49GVC	MUD FLAPS, REAR WHEELS (2) Rubber
49GWW	WINDSHIELD WASHER Kit; 6 Quart Capacity, Bottle  <u>Includes</u> : WINDSHIELD WASHER ELECTRICAL CONNECTIONS Sealed and Locking Type
49GBV	WINDSHIELD WIPERS (2) Cowl Mounted  <u>Includes</u>

**Vehicle Specifications**  
**2024 INTEGRATED CE S BUS (PB105)**

September 14, 2022

<u>Code</u>	<u>Description</u>
49UBZ	: WINDSHIELD WIPERS CONTROL Single Motor, Overlapping Wipe Pattern STATE OF OPERATION Texas

**Services Section:**

**WARRANTY**

---

40126	WARRANTY Standard for CE, RE, BE School Bus Models, Effective with Vehicles Built March 1, 2017 or Later, CTS-3304H
40RAP	SERVICES, TOWING {Navistar} Service Call to 24-Month/Unlimited Mileage to the Nearest IC Bus Dealer for Navistar Warrantable Failure as Contract Defined; Includes Engine Failure if Supplier Declines Tow Coverage & ESC Supplied thru Navistar; \$1100 (USA) Maximum Benefit per Incident
40PKZ	SRV CONTRACT, EXT VEH COVERAGE {Navistar} To 24-Month/50,000 Miles (80,000 km), Covers 100% Parts and Labor; Includes Body; Excludes Extending Warranty for Engine, Transmission, Perforation or Corrosion of Cab/Cowl Structure and Paint

**BODY FEATURES**

---

49GVN WARRANTY 5-Year, Limited

**Body/Allied Equipment**

<u>Code</u>	<u>Description</u>
-------------	--------------------

**Goods Purchased**

<u>Code</u>	<u>Description</u>
-------------	--------------------

SET GOVERN SPEED @ 55 MPH

PRE DELIVERY INSPECTION CE MODEL

136KBTU BERGSTROM AC FRONT/REAR/MID/DASH SKIRT CONDENSERS!

DEFROST KIT - AC

STATE INSPECTION - WW SALES

WEIGHT SLIP WW SALES

**Financial Summary**  
**2024 INTEGRATED CE S BUS (PB105)**

September 14, 2022

<u>Description</u>	<u>(US DOLLAR)</u>	<u>Price</u>
Net Sales Price:		\$123,552.00

Please feel free to contact me regarding these specifications should your interests or needs change. I am confident you will be pleased with the quality and service of an IC Corporation vehicle.

Prices are good for 30 days from the date of this proposal.

PRICE PER BUS: \$123,552.00

\*\*\*OPTIONAL ITEMS TO CONSIDER (Not included in above pricing)\*\*\*  
UPGRADE TO ROSCO HEATED REAR VIEW SIDE MIRRORS W/TIMER: ADD \$105 PER BUS

Estimated delivery: 290-330 Days (Diesel) & 180-240 Days (LPG) from receipt of a purchase order. Longhorn Bus Sales will not be held responsible for material shortages or delays due to the global COVID-19 pandemic or any other reasons outside of our control, that of the represented OEM (IC Corp) or third-party vendors used to complete a customers bus order. A bus order may be delivered without OEM or third-party products (i.e., A/C, GPS, two way radios, camera surveillance equipment, etc.), and any such items will be installed immediately upon availability. These shortages/delays will not hold up invoicing and or payment. Due to industry constraints, quote pricing may fluctuate.

Price does not include Buy Board fee of \$800 per purchase order, please add if applicable. Buy Board contract 630-20.

40PKZ Warranty: Longhorn Bus Sales will cover the warranty for 24 months/unlimited mileage. (Navistar will cover the first 50K miles. Longhorn Bus will cover 50K+ miles, up to the ending of the 24 month period, as per current Texas School Bus Specifications.

Code "49GVN WARRANTY 5-Year, Limited" is a Navistar body warranty only, it does not apply to any aftermarket parts.

By signing this document in acceptance of an order, the customer acknowledges that all equipment listed within this document is correct. Longhorn Bus Sales will not be responsible for any miss-built units. Any changes to what is listed herein, may result in additional charges to the order. Thank you.

**Approved by Seller:**

**Accepted by Purchaser:**

LHB Sales 09.14.2022

Official Title and Date

*Frederick A. Hoke, Jr.*  
Authorized Signature

Firm or Business Name

Authorized Signature and Date

**This proposal is not binding upon the seller without Seller's Authorized Signature**

Official Title and Date

**The TOPS FET calculation is an estimate for reference purposes only. The seller or retailer is responsible for calculating and reporting/paying appropriate FET to the IRS.**

**The limited warranties applicable to the vehicles described herein are Navistar, Inc.'s standard printed warranties which are incorporated herein by reference and to which you have been provided a copy and hereby agree to their terms and conditions.**

LEFT SIDE ABOVE FLOOR OR  
LOW PROFILE ABOVE FLOOR OR  
BELOW FLOOR FUEL FILL  
OPTIONS NOT AVAILABLE

VERTICAL HINGED E/E  
REQUIRED

CHK	DATE	CHANGE	REV	REFERENCE
MLA	13NOV19	REMOVED SEAT LABELS FROM 2ND & 3RD ROW SEATS	A	

BODY PLAN

WHEELBASE 276"

PB10500, 34 FT. 11 IN., PLUS 9 RR, CAP 71, SEAT SIZE VARIES, SEAT SPACING VARIES

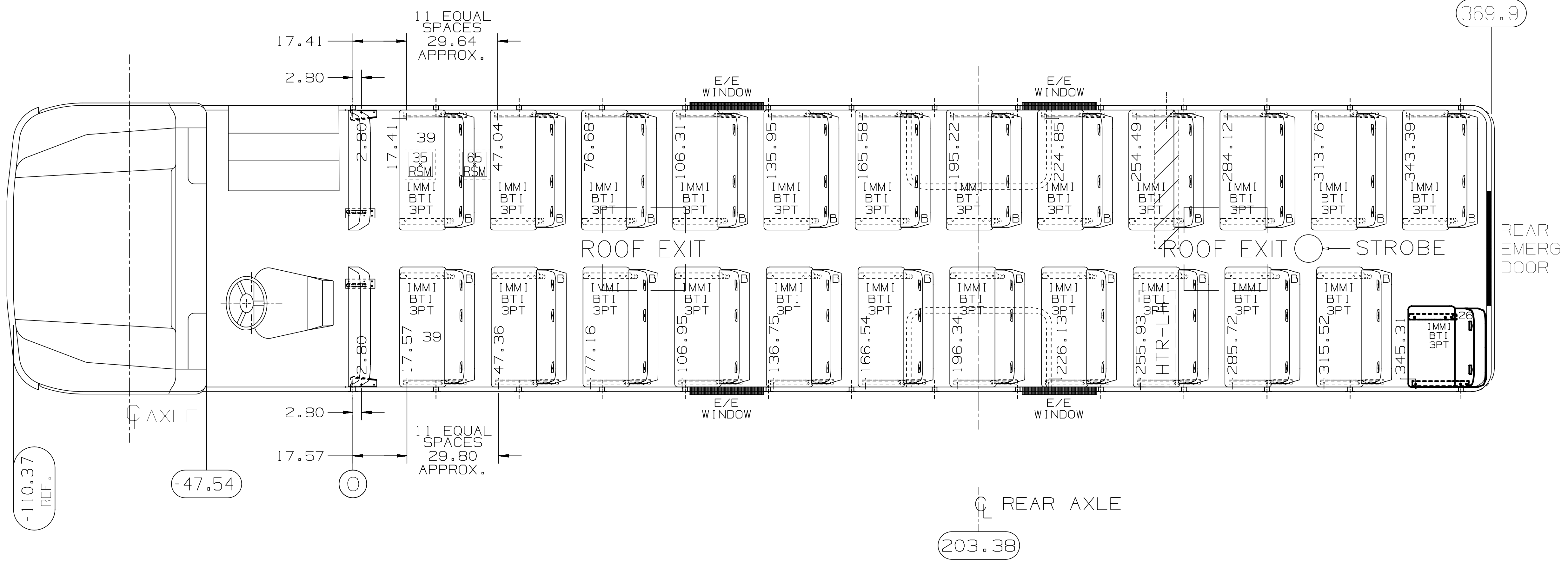

PURCHASED SEATS IN THIS UNIT ARE :  
BTI (3P)

THIS UNIT CONFORMS TO APPLICABLE FMVSS THIS DOCUMENT IS IN ACCORDANCE WITH ASME Y14.5M-1994 AS AMENDED BY THE INTERNATIONAL TRUCK DIVISION DIMENSIONING AND TOLERANCING ADDENDUM-2000.

50UXN/49001

INTERNATIONAL TRUCK AND ENGINE CORPORATION  
INTERNATIONAL\*CONFIDENTIAL PROPRIETARY

REFERENCE: LHORN-1670

LINEAR MEASURE:  mm  in

UNLESS SPECIFIED DIM TOLERANCES ARE:

	mm	in
ONE PLACE (.X)	+1.5	+0.06
TWO PLACE (.XX)	+0.8	+0.03
THREE PLACE (.XXX)	+0.25	+0.010

ANGLES: ±1°

THIRD ANGLE PROJECTION

NAME: BODY PLAN PB10500

CONTROL: E 50

VERSION: E

APPROVED: U00MACH

DATE: 09JAN19

SCALE: NONE

SIZE: 4

PART NO.: DX9714A001

SHEET: 01

FRAME



**OBTAINING SERVICE**

Return this vehicle to any IC Bus Dealer authorized to service this model vehicle and engine.

**DISCLAIMER**

NO WARRANTIES ARE GIVEN BEYOND THOSE DESCRIBED HEREIN. THIS WARRANTY IS IN LIEU OF ALL OTHER WARRANTIES, EXPRESSED OR IMPLIED. THE COMPANY SPECIFICALLY DISCLAIMS WARRANTIES OF MERCHANTABILITY AND FITNESS FOR A PARTICULAR PURPOSE, ALL OTHER REPRESENTATIONS TO THE USER/PURCHASER, AND ALL OTHER OBLIGATIONS OR LIABILITIES. THE COMPANY FURTHER EXCLUDES LIABILITY FOR INCIDENTAL AND CONSEQUENTIAL DAMAGES, ON THE PART OF THE COMPANY OR SELLER. No person is authorized to give any other warranties or to assume any liabilities on the Company's behalf unless made or assumed in writing by the Company; and no other person is authorized to give any warranties or to assume any liabilities on the seller's behalf unless made or assumed in writing by the seller.

**Remedies Under State or Provincial Law:** Any suit for breach of this Limited Warranty must be initiated within one year after breach. Some States and Provinces do not allow the exclusion or limitation of incidental or consequential damages, so the above limitation or exclusion may not apply to the owner. This warranty gives the owner specific legal rights, and he may also have other legal rights which may vary by state or province.

**RECORD OF OWNERSHIP**

Upon receipt of new vehicle by original owner, complete the following:  
I have read this Warranty Brochure and fully understand the warranty coverage, and the limitations and exclusions. I acknowledge that I have received a copy of the Owner's Limited Warranty and I accept the terms described herein.

_____	_____
Customer Signature	Date
_____	_____
Owner's Address	City State/Prov Postal Code
_____	_____
Bus Model	Vehicle Identification Number
_____	_____
Engine Number	Engine Serial Number
_____	_____
Date Delivered to User (DTU)	Odometer Reading at Delivery

**IMPORTANT:** The information contained in this Warranty Policy explains the coverage provided on your new IC Bus™ brand vehicle. This policy should be kept in the vehicle for presentation to the Dealer when you request warranty services.

Any provisions of this Limited Warranty that are prohibited or not enforceable in any jurisdiction shall be, as to such jurisdiction, ineffective to the extent of such prohibition or non-enforceability without invalidating the remaining provisions hereof, and any such prohibition or non-enforceability in any jurisdiction shall not invalidate or render non-enforceable any such provisions in any other jurisdiction.

All claims under this Limited Warranty must be submitted in writing to an authorized IC Bus dealer within the warranty period as stated herein. If you have questions regarding this Limited Warranty, contact IC Bus, LLC dealer. To locate nearest dealer, visit the IC Bus website [www.ICBus.com](http://www.ICBus.com).

**EFFECTIVE WITH VEHICLES BUILT MARCH 01, 2017 OR LATER**

**LIMITED WARRANTY FOR SCHOOL BUS MODELS**

**CE Series (PB105), RE Series (PB305), BE Series (PB405)**

IC Bus, LLC warrants to the original purchaser (the "Purchaser") that IC Bus, LLC brand buses and component parts thereof are, at the time of purchase, free from defects in material and workmanship and will remain free from such defects under normal use after delivery to the Purchaser as provided herein. Warranty shall begin at the time of delivery unless otherwise approved by IC Bus, LLC. The delivery limitations as set forth herein shall run from the date of delivery to the Purchaser in the United States of America and Canada. The remedy available under this Limited Warranty is non-cumulative in nature and is limited to repair or replacement at IC Bus, LLC option of the bus or component parts thereof that are returned to locations approved by IC Bus, LLC transportation charges prepaid, and which IC Bus, LLC examination disclosed to its satisfaction to be defective. IC Bus, LLC, at its option, will repair or replace any part of this vehicle which proves defective in material and/or workmanship in normal use and service, with new or ReNEWed parts. Exceptions are listed below under *What Is Not Covered*.

*This warranty is automatically transferred to subsequent owners at no charge. Visit your local IC Bus Dealer for name and address change information.*

**COMPONENT COVERAGE**

The components described below are given additional warranty coverage of variable time periods and distance traveled limitations, as shown in the *Warranty Coverage Schedule*.

1. Frame Rails and Crossmembers
2. Body/Cowl Structure
  - Body Structure defined as the steel body frame (which includes the roof, metal floor, sides and front and rear sections only).
  - As to items not considered Body Structure include but are not limited to the following: doors, corner moldings, inner ABS panels, interior wall, plywood, floor covering, windows, and trim moldings.
3. The Body/Cowl is warranted against perforation due to corrosion, except for perforation caused by industrial chemicals and/or corrosion caused by use in a corrosive industrial environment.
4. Navistar Diesel Engine Coverage Includes: Navistar Diesel Engine block, cylinder heads, internally lubricated components fuel pump, high pressure pump, turbocharger, water pump, air compressor, injectors/nozzles; electronic engine modules, engine relays, engine sensors and regulators required for electronic engine operation, and certain aftertreatment components. Excluding: attaching accessories (e.g., fan clutch, alternator, starter, etc.), and externally mounted electrical and filtration systems.
5. Power Solutions International 8.8L Propane and Gas Engine Coverage Includes: Engine block, cylinder heads, internally lubricated components, water pump, air compressor, injectors/nozzles, fuel system components; electronic engine modules, engine relays, engine sensors and regulators required for electronic engine operation, exhaust catalyst. Excluding: attaching accessories (e.g., fan clutch, alternator, starter, etc.)
6. Spicer front & rear axles and propeller shaft, when used with Allison transmission; excluding brakes, wheel ends axle shafts, controls & attachments.

THE PROVISIONS HEREOF CONSTITUTE THE EXCLUSIVE AND COMPLETE WARRANTY BY IC BUS, LLC ON IC BUS™ BRAND BUSES AND COMPONENT PARTS THEREOF MANUFACTURED BY IT, OR APPROVED BUS BODY CONTRACT MANUFACTURERS AND IS IN LIEU OF ALL OTHER OBLIGATIONS OR LIABILITIES OF IC BUS, LLC WHETHER EXPRESS OR IMPLIED.

**Note:** The customer has 365 days and up to a maximum of 100,000 miles (160,000 km) from DTU (delivery to end user) to purchase an extended warranty on the unit. For extended warranty purchases between 181 and 365 days from DTU and <100,000 miles (160,000 km) an additional fee will be assessed. See your local IC Bus dealer for details.



Items Covered	Months	Miles/Km (000)
<b>BASIC VEHICLE COVERAGE</b>		
Basic Vehicle Warranty	12	Unlimited
Towing (Chassis related issues)	3	Unlimited
Towing (Vehicles with Navistar built engine failures only)	24	Unlimited
Towing (Vehicles with Power Solutions International, Inc. 8.8L Propane engine failures only)	60	Unlimited
Towing (Vehicles with Power Solutions International, Inc. 8.8L Gasoline engine failures only)	60	Unlimited
<b>COMPONENTS</b>		
Frame Rails and Crossmembers	60	Unlimited
Body/Cowl Structure (Roof, Metal Floor, Sides and Front and Rear Sections)	60	Unlimited
Body/Cowl Perforation Corrosion	60	Unlimited
Bumper Corrosion and Paint Delamination	36	Unlimited
Body/Cowl/Hood Paint Delamination	60	Unlimited
Brightwork, Chassis Paint and Corrosion	6	Unlimited
IC Bus, LLC Factory Installed Air-Conditioning (IC Air)	30	Unlimited
<b>SEATS***IC Bus manufactured Seats Only</b>		
Foam	48	50/80
Upholstery	24	24/40
Frame and Barriers	60	Unlimited
<b>ENGINE*</b>		
Power Solutions International, Inc. 8.8L Propane Engine	60	Unlimited
Power Solutions International, Inc. 8.8L Gasoline Engine	60	Unlimited
<b>DRIVETRAIN**</b>		
Eaton Precision Transmission	12	Unlimited
Spicer - 3 Part Dana Drivetrain (Front & Rear Axles, Propeller Shaft, When Used With Allison Transmission Only)	48	50/80
Meritor Axles	48	75/120

**WHAT IS NOT COVERED**

**AFTER THE FIRST 90 DAYS FROM DELIVERY TO USER (DTU):**

- Correction of loose fasteners, squeaks, rattles and unusual noises.
- Towing (vehicles with non-engine failures only)
- Adjustments (e.g., headlights, brake/clutch adjustments, steering system adjustments, coolant levels, doors).

**COMPONENTS / ITEMS:**

- Warranted by their respective manufacturers (e.g., non Navistar brand engines, tires & tubes, Allison Transmissions, Hybrid electric, lubricants, etc.)
- Bodies, equipment and accessories installed by other than authorized IC Bus employees at IC Bus manufacturing plants.
- Front and rear axle alignment.
- Front & Rear axle coverage excludes brakes, wheel ends, axle shafts, controls & attachments.

**REPAIRS:**

- Maintenance-related items/repairs or those as a result of normal wear and tear, including tune-ups, brake/clutch lining, windshield wiper blades, tire balancing, lubrication and other similar procedures/parts required to keep vehicle in good working condition.
- To any part of the vehicle subjected to misuse, negligence, improper maintenance, improper operation, or which is the result of an accident.
- Fade, runs, mismatch or damage to paint, trim items, upholstery, chrome, polished surfaces, etc., resulting from environmental causes, improper polishes, cleaners or washing solutions, or chemical and industrial fallout.
- In which power train, propeller shaft and suspension sales guidelines (specifications) are not strictly adhered to by all owners and operators of this vehicle.

**OTHER:**

- Vehicles sold and/or operated outside the United States and Canada.
- Vehicles/components that have had unauthorized alterations or modifications.
- Vehicles on which the odometer reading has been altered.
- Loss of time or use of the vehicle, loss of profits, inconvenience, or other consequential or incidental damages or expenses.
- Replacement of defective parts with parts other than those provided by IC Bus, LLC.

***This warranty does not apply, or include coverage for defects attributable to the following:***

- (a) Damage resulting from: (i) misuse, abuse, accident, neglect, negligence, vandalism, fire, riot, war, or Acts of God;
- (b) (ii) Structural or other modifications or alteration without prior express written authorization by IC Bus, LLC; (iii) Repair or attempted repair by unauthorized persons; (iv) Replacement of original components with substitutes without prior express written authorization by IC Bus, LLC; (v) Failure to perform routine preventative maintenance as customarily accepted within the industry or failure to provide proof of such preventative maintenance having been performed; (vi) Exposure to corrosives, contaminants, chemicals, salt, irradiation or atmospheric or environmental conditions; (vii) Usage or loading in excess of recommended capacities or in non-standard applications, including off-road.
- (c) Fading or discoloration of paint, lettering or decals.
- (d) Effects of aftermarket installation and aftermarket parts installed by the dealer or customer.

\*Emission Coverage: Refer to engine operator's manual for emission coverage.

\*\*Drivetrain:

- Allison Transmissions products or Transynd lubricants and fluids are not covered under this warranty. For warranty information see: [www.allisontransmission.com/publications/](http://www.allisontransmission.com/publications/)
- For specific Eaton/Fuller Warranty coverage, see supplier information: [www.roadrangerwarranty.com](http://www.roadrangerwarranty.com)
- For extended component warranty: [www.roadranger.com/Roadranger/warranty/Extended\\_Warranty/index.htm](http://www.roadranger.com/Roadranger/warranty/Extended_Warranty/index.htm)

\*\*\*For non IC Bus Manufactured seats, contact the seat supplier for their warranty coverage. For Enova charge sustaining and charge depleting standard warranty to: <http://enovasystems.com/customer-support.html>

\*1/24/2019 removed MaxxFace Engines from coverage as Buses built post March,1,2017 no longer offered this engine.



**Revised 4/1/2019**

**Telematics Data Disclosure**

***Your Navistar vehicle may include an activated telematics subscription service. By accepting this Limited Warranty you consent to our collection and use of data from your vehicle as set forth at [www.oncommandconnection.com](http://www.oncommandconnection.com) on behalf of yourself and any vehicle operators and passengers. Navistar, Inc. or its affiliates will collect and send diagnostic and system data from your vehicle and use it for various purposes as further set forth in our Privacy Policy, posted at [www.oncommandconnection.com](http://www.oncommandconnection.com), such as improving the uptime for your vehicle, improving our vehicles in the future, and reducing warranty events. If you choose not to allow Navistar to access your data, you may suspend your subscription at [www.InternationalTrucks.com/Opt-Out](http://www.InternationalTrucks.com/Opt-Out)***

**RE/CE BUS EXTENDED VEHICLE COVERAGE  
INCLUDING BUS BODY**

This **Extended Vehicle Coverage Including Bus Body option(s)** provides coverage for time or distance traveled from new vehicle delivery date, whichever expiration occurs first.

During the period selected, Navistar, Inc. will repair or replace any of the covered components as defined below which proven defective in material and/or workmanship in normal use, with new or ReNEWed parts. Exceptions are listed herein under *What is Not Covered*.

**GROUP 01 - FRAME AND BUMPER**

- |                           |                                |                                |
|---------------------------|--------------------------------|--------------------------------|
| 067 - Carrier, Tire       | 306 - Outtrigger, Bus Platform | 581 - Bumper Frame             |
| 071 - Bumper              | Mounting                       | 660 - Rail, Frame Side         |
| 211 - Bracket or Mounting | 307 - Crossmember              | 739 - Reinforcement or Gussets |
|                           | 309 - Crossmember, Engine      |                                |

**GROUP 02 - FRONT AXLE**

- |                          |                         |                          |
|--------------------------|-------------------------|--------------------------|
| 016 - Arm, Steering      | 353 - Fitting/Zerk      | 667 - King Pin & Bushing |
| 032 - I-Beam, Front Axle | 535 - Knuckle, Steering | 799 - Seal, King Pin     |

**GROUP 03 - SUSPENSION**

- |  |  |                                    |
|--|--|------------------------------------|
| 062 - Equalizer / Rocker Arm and Bushing | 264 - Control (Air Suspension Only)            | 468 - Spring Leaf Assembly         |
| 066 - Torque Arm & Bushing Assembly      | 341 - Bracket, Shock Absorber Mounting         | 584 - Bracket Assembly, Spring     |
| 074 - Walking Beam & Bushing Assembly    | 406 - Bolt, Center                             | 646 - Shackles, Pins & Bushing     |
| 203 - Air Bag Assembly                   | 437 - Suspension Air Control Manifold Assembly | 711 - Crossmember, Rear Suspension |
|  | 438 - Suspension, ECM                          | 769 - Sway Bar Assembly            |
|  |  | 804 - Stop, Axle                   |

**GROUP 04 - BRAKES**

- |  |   |  |
|--|---|--|
| 003 - Tank, Air, Vacuum                        | 429 - Cable/Linkage, Parking Brake                    | 811 - Relay/Magnetic Switch                      |
| 005 - Knob                                     | 461 - Linkage / Cam / Camshaft, Wheel Brake Actuating | 812 - Valve, Modulator                           |
| 007 - Pumps                                    | 462 - Linkage/Pedal/Spring Brake Actuating            | 816 - Sender, Wheel                              |
| 009 - Accumulators                             | 511 - Power Assist Unit                               | 826 - Caliper                                    |
| 010 - Hydraulic Power Brake (HPB) Unit         | 617 - Backing Plate/Anchor/Dust Shield                | 840 - Caliper Bracket                            |
| 012 - Solenoid Valve                           | 634 - Pump, Back-Up (Less Motor)                      | 842 - Switch, Flow                               |
| 013 - Adjuster, Slack                          | 636 - Motor, Back-Up                                  | 846 - Switch, Back-Up Motor                      |
| 020 - Cylinder, Self Actuate Hydraulic Release | 643 - End Cover, Unloader Valve Air Dryer             | 847 - Switch, Pressure Differential              |
| 036 - Adjuster Assembly, Automatic             | 662 - Spring, Brake Shoe Return                       | 848 - Module, Monitor                            |
| 105 - Bracket, Brake Chamber                   | 747 - Spring Applied Air Release (Saar) Canister      | 851 - Valve, Spring Brake Control                |
| 231 - Chamber                                  | 751 - Sensor, Steering Angle                          | 852 - Brake Assembly, Drive Line                 |
| 232 - Diaphragm, Chamber                       | 753 - Sender, Stability Control                       | 909 - Harness, Cab                               |
| 255 - Cylinder, Master                         | 801 - Control Unit, Electronic ECU                    | 913 - Valve, Foot Control or Pedal               |
| 390 - Reservoir                                |   | 920 - Valve, Hand Control                        |
| 392 - Switch, Fluid Level                      |   | 923 - Harness, Front End (Wires/Connectors/Term) |
| 397 - Governor and Mounting, Air               |   | 932 - Valve, Front Wheel Limiting & Mounting     |
| 428 - Lever/Pedal, Parking Brake               |   |  |

940 - Harness, PDM  
Distribution

## **GROUP 05 - STEERING**

018 - Arm, Pitman  
069 - Link, Drag  
164 - Column Assy. &  
Mounting, Steering  
167 - Wheel Mechanism, Tilt  
Steering  
206 - Couplings/U-Joint,  
Steering Shaft

## **GROUP 06 - PROP SHAFT**

101 - Bearing  
165 - Mounting, Bearing

## **GROUP 07 - EXHAUST**

107 - Assembly, Basic  
143 - Bracket/Support,  
Mounting  
426 - Guard / Heat Shield

## **GROUP 08 - ELECTRICAL**

005 - Knob  
018 - Alternator Assembly  
038 - Multiplex Signal Module  
(MSM)  
041 - Telematics Control  
Module (TCM)  
049 - Switch, SOS  
059 - Regulator, Voltage  
063 - Solenoid Base, Pneumatic  
Accessory  
065 - Solenoid Unit, Pneumatic  
Accessory  
073 - Amplifier, Pyrometer  
074 - Gauge, Voltmeter  
076 - Gauge, Fuel Level  
088 - Gauge, Oil Pressure  
(Electrical)  
097 - Gauge, Coolant  
Temperature (Electrical)  
099 - Gauge, Ammeter  
109 - Gauge, Engine Oil  
Temperature  
110 - Gauge, Pyrometer  
111 - Gauge, Rear Axle Oil  
Temperature  
116 - Gauge, Speedometer  
(Electrical)  
117 - Gauge, Tachometer  
(Electrical)  
118 - Gauge, Transmission Oil  
Temperature  
124 - Sender, Fuel Level

944 - Valve, Quick Release  
955 - Pully

252 - Wheel, Steering  
311 - Gear Assembly, Steering  
314 - Gasket, Power Steering  
Pump Mounting  
316 - Wheel Mechanism,  
Telescoping Steering  
370 - Bracket/Mounting,  
Steering Gear

391 - Joint, Universal  
475 - Boot / Clamp, Slip Joint

533 - Tail Pipe, Exhaust Gas  
Cooler  
551 - Pipe, Crossover  
576 - Pipe & Flange, Exhaust

127 - Tachometer/Trip Recorder  
(Elec Driven)  
155 - Sender, Pyrometer  
156 - Sender, Rear Axle Oil  
Temperature  
159 - Sender, Transmission Oil  
Temperature  
202 - Motor, Starter  
217 - Solenoid, Starter Motor  
221 - Bezel/Cover Plate  
223 - Circuit Board  
224 - Switch, Speedometer /  
Tachometer Dip  
(Reprogramming Only)  
225 - Panel, Circuit  
Breaker/Relay/Fuse  
226 - Mounting, Circuit  
Breaker/Relay/Fuse Panel  
251 - Harness, Coiled Ribbon  
(Clock Spring)  
266 - Switch, Clutch  
269 - Module, Coolant Probe  
270 - Probe, Coolant Level  
284 - Antenna and Lead-In  
347 - Mounting  
372 - Module, Pyrometer  
373 - Module, Ammeter  
374 - Circuit Housing,  
Speedometer / Tachometer  
375 - Sender, Air Pressure  
388 - Lamp Assembly

990 - Wiring

555 - Cylinder Assembly &  
Valves  
653 - Cooler Assembly, Oil  
701 - Pump Assembly  
757 - Reservoir Assembly  
818 - Valve, Control  
955 - Pulley

478 - Shaft  
703 - Yoke/Spline

615 - Pipe/Stack, Tail  
775 - Cap, Stack  
824 - Pipe, Flex

401 - Clean Power Cable  
(Battery To Cab)  
404 - Flasher  
405 - Beeper, Hydraulic Brake  
Warning  
407 - Alarm, High Water  
Temp/Low Oil Press.  
408 - Beeper, Low Air Pressure  
418 - Regulator & Motor  
Assembly  
424 - Hourmeter  
430 - Odometer  
487 - Horn Assembly  
499 - Contact Ring/Button, Horn  
508 - Monitor, Driver Display  
Unit  
510 - Sensor, Radar Side/Front  
511 - Camera, Forward Looking  
512 - Display, Side Sensor  
514 - Sensor, Turn Assembly  
516 - Magnet, Turn Sensor  
Assembly  
518 - Harness, Side Sensor  
585 - Automatic Headlight  
Sensor  
586 - Antenna, Tire Pressure  
Monitor  
587 - Brake Stroke Chamber  
W/Sensor  
588 - Display, Vehicle  
Information

589 - Fuel Filter Restriction  
Globe W/Sensor  
595 - Module/Controller, Tire  
Pressure Monitor  
596 - Module, Vehicle Sensor  
598 - Batteries, Jumper Cable  
599 - Sensor, Brake Pad Wear  
601 - Wheel Module, Tire  
Pressure Monitor  
607 - Switch, Air Horn  
608 - Clock  
609 - Switch, Cruise On/Off  
618 - Switch, Cruise Set/Reset  
620 - Switch, Engine Brake  
On/Off  
621 - Switch, Headlight  
Interrupt  
623 - Switch, Marker Interrupt  
624 - Switch, Radio  
628 - Switch, Transmission  
Mode  
629 - Switch, Transmission Shift  
637 - Alarm, Back-Up

## **GROUP 09 - COOLING**

012 - Solenoid Valves  
022 - Core  
026 - Shutter Assembly  
047 - Hose/Pipe, Radiator  
064 - Tank & Neck, Radiator  
083 - Shroud Clamp  
085 - Shroud Mounting Bracket  
091 - Shroud, Engine Mounted  
108 - Cylinder Assembly,  
Actuating  
123 - Mounting, Radiator  
136 - Motor  
142 - Rod Assembly, Control

## **GROUP 10 - INSTRUMENTS**

053 - Head Assembly

## **GROUP 11 - CLUTCH**

059 - Bearing and Sleeve  
Assembly, Release  
101 - Cylinder, Master  
133 - Cylinder, Slave

## **GROUP 12 - ENGINE**

222 - Solenoid  
740 - Blade Assembly, Fan  
744 - Fan Drive, Viscous  
746 - Fan Drive, On/Off  
748 - Control, Fan Clutch  
750 - Pulley, Fan  
802 - Sart Module

705 - Solenoid, Air  
718 - Solenoid  
743 - Clean Power Cable (Batt  
to Engine Connect  
745 - Daytime Running Light  
Switch  
758 - Central Processing Unit  
(CPU)  
783 - Compass, Electronic  
784 - Thermometer, Electronic  
797 - Clean Power Cable (Batt  
to Transmission)  
811 - Relay/Magnetic Switch  
815 - Switch, Key/Ignition  
821 - Switch, Push Button  
Starter  
828 - Switch, Dimmer  
835 - Switch, Back-Up Light  
840 - Switch, Neutral Start  
848 - Module Monitor  
850 - Switch, Low Oil Pressure  
854 - Controller, Esc  
863 - Switch, Stoplight (Air)

176 - Shroud  
197 - Shutterstat  
210 - Glass, Sight  
211 - Tank & Mounting, Surge  
222 - Solenoid  
240 - Motor / Pump  
427 - Bottle and Hose, Coolant  
Recovery  
504 - Fan Module  
616 - Cooler, In Tank Oil  
701 - Pump Assembly  
740 - Blade Assembly, Fan  
755 - Electronic Fan Controller

292 - Fork and Cross Shaft,  
Clutch Release  
349 - Lever Assembly, Relay  
403 - External Linkage

811 - Relay/Magnetic Switch  
814 - Pedal Assembly,  
Accelerator  
828 - Front Mount/Bolt  
836 - Rear Mount/Bolt  
865 - Switch, Temperature

864 - Switch, Stoplight  
(Hydraulic)  
865 - Switch, High Water  
Temperature  
870 - Switch, Low Air Pressure  
871 - Switch, Low Coolant  
Level  
872 - Switch, Parking Brake  
884 - Switch, Headlight  
885 - Switch, Marker/Interrupt  
886 - Switch, Turn Signal  
887 - Programming  
907 - Actuator, Switch Pack  
908 - Switch Pack (Base)  
909 - Harness, Cab Wires  
Conn's & Terminals  
923 - Harness, Front End  
(Wires, Connectors And  
940 - Harness, PDM  
Distribution  
955 - Pulley  
996 - Monitor, Battery Run  
Down Protection

756 - Hydraulic Fluid Reservoir  
767 - Oil Cooler (Oil-To-Air)  
811 - Relay/Magnetic Switch  
852 - Pipe, Charge Air Cooler  
865 - Switch, Temperature  
909 - Harness, Cab  
(Wires/Connectors/Term)  
925 - Charge Air Cooler,  
Chassis Mounted  
940 - Harness, PDM  
Distribution

440 - Self Adjusting Mechanism  
462 - Pedal  
639 - Intermediate Plat  
862 - Plate Assembly, Pressure

905 - Bracket, Air Compressor  
Mtg.  
909 - Harness, Cab  
(Wires/Connectors/Term)  
911 - Bracket, Alternator Mtg.  
914 - Bracket, Refrigerant  
Compressor Mounting

919 - Bracket, Power Steering  
Pump Mounting  
930 - Coupling, Accessory  
Drive

## **GROUP 13 - TRANSMISSION**

114 - Case  
125 - Flange, Companion  
138 - Block, Resistor  
139 - Housing, Bell  
191 - Retainer, Bearing  
313 - Detent Poppet Ball &  
Spring

## **GROUP 14 - REAR AXLE**

013 - Adjuster, Slack  
016 - Arm, Steering  
068 - Spring, Lift  
135 - Flange/Yoke, Comp  
147 - Carrier  
170 - Housing, Axle  
203 - Air Bag Assembly  
216 - Stud  
231 - Chamber  
265 - Control (Air Suspension  
Control)  
323 - Hanger and Crossmember  
Assembly

## **GROUP 15 - FUEL SYSTEM**

011 - Cap/Scoop, Air Inlet  
014 - Box/Water Separator, Air  
Inlet  
026 - Pipe, Air Inlet  
029 - Control System, Air Inlet  
Temperature  
142 - Pre-Heater Element  
143 - Valve, Drain  
144 - Valve, Check  
145 - Cap, Vent

## **GROUP 16- CAB**

006 - Stop, Hood  
018 - Bezel, Head or Tail Lamp  
027 - Step, Cab  
053 - Cable, Hood  
071 - Channel, Glass Run  
078 - Remote Control/Cable,  
Door  
086 - Crossmember, Cab  
Mounting  
102 - Cab Tilt Lock Mechanism  
103 - Cab Tilt Hinge  
Mechanism  
104 - Cowl/Firewall/SC or FC  
Platform

938 - Gear, Power Steering  
Pump Driver  
946 - Tensioner, Belt  
955 - Pulley/Idler/Bearing

616 - Cooler, Oil (Oil-To-Air)  
677 - Line, Oil Cooler  
785 - Linkage/Cable, Remote  
Shift Control  
825 - Switch, On/Off  
839 - Switch, Brake  
866 - Mounting

357 - Bearings, Internal (Axle  
Carrier)  
376 - Gears, Bushings & Cross,  
Differential  
395 - Differential, Limited Slip  
424 - Bolt, Ring Gear  
441 - Wheel End Gearboxes  
448 - Gears, Helical  
472 - Gears, Planetary  
496 - Gears, Ring & Pinion  
590 - Shaft, Helical Drive Gear  
606 - Clutch, Sliding  
619 - Control, Air Shift

146 - Pump, Primer  
147 - Collar  
148 - Body  
177 - Filler Neck/Cap & Gasket  
196 - Sensor, Water in Fuel  
216 - Bracket, Stack Mounting  
263 - Air Intake Grill  
479 - Finish (Metal)  
500 - Bracket & Bolts,  
Mounting

121 - Suspension, Sleeper Bunk  
122 - Cylinder, Lift  
123 - Latch Assembly  
129 - Cabinets  
130 - Door  
131 - Window, Sleeper  
135 - Cylinder, Lift  
139 - Door Assembly, Radiator  
Access  
146 - Shade, Sun  
248 - Grille Assembly  
264 - Handle, Grab  
265 - Handle, Hood  
282 - Hinge

909 - Harness, Cab (Wires,  
Connectors & Term)  
940 - Harness, PDM  
Distribution

630 - Cylinder, Air Shift  
654 - Fork, Shift  
679 - Motor, Air Shift  
707 - Bearing/Ret, P.D.  
713 - Pump, Oil  
719 - Case, P.D. Diff.  
730 - Gears/Bushing & Cross  
Power Divider  
747 - Tank, Air Or Vacuum  
969 - Knuckle, Steerable  
970 - King Pin, Knuckle

637 - Tank Body  
787 - Tube, Fuel Outlet  
857 - Indicator, Air Restriction  
890 - Transfer Pump, Electric  
(Tank to Tank)  
892 - Valve/Control, Fuel Tank  
909 - Harness, Cab Wires  
Conn's & Terminals  
976 - Vent, Air  
988 - Guard, Crash

291 - Hinge, Hood/Engine  
Access Door Hatch  
295 - Hood Guides  
300 - Bunk Occupant Restraint  
Strap/Tent  
301 - Cowl Tray  
309 - Hood  
329 - Insulation  
330 - Shield, Sound  
336 - Insulation, Engine  
Compartment  
345 - Latch & Exterior Handle  
362 - Latch, Hood

368 - Latch, Doghouse  
 Panel/Engine  
 398 - Map Pocket, Passenger  
 Door  
 409 - Air Intake Baffle/Water  
 Sep. Baffle  
 421 - Mirror, Spot  
 423 - Mirror, Exterior (Basic)  
 433 - Mirror, Interior  
 459 - Mounting, Front Cab  
 463 - Mounting, Intermediate  
 Body  
 468 - Mounting  
 546 - Panel, Back  
 555 - Doghouse Panel/Engine  
 Cover  
 567 - Panel, Floor  
 568 - Panel, Halo  
 569 - Panel, Engine Surround  
 584 - Panel, Instrument  
 611 - Panel, Splash  
 619 - Panel / Skin  
 625 - Rivet/Fastener  
 627 - Weld

637 - Structure  
 666 - Regulator & Handle,  
 Window  
 675 - Arm Rest  
 684 - Roof  
 721 - Spring/Shock Absorber &  
 Mounting, Cab  
 739 - Stop Assembly, Door  
 748 - Sub-Frame  
 799 - Console  
 802 - Manifest Box/Door Pouch  
 804 - Trim, Interior  
 805 - Trim, Bunk  
 806 - Mirror, Interior  
 807 - Under Bunk Lift Assist  
 Shock  
 811 - Relay/Magnetic Switch  
 (Electric Mirror)  
 825 - Switch, Electric Mirror  
 833 - Valve, Control  
 844 - Ventilator  
 855 - Visor, Sun  
 877 - Vent Window & Seal  
 896 - Trim, Hood

909 - Harness, Cab  
 (Wires/Connectors/Term)  
 926 - Shor Power Connection  
 928 - Door, Hood / Engine  
 Access  
 929 - Hinge / Bracket, Front  
 Hood Mounting  
 934 - Reinforcement, Hood  
 935 - Torsion Bar, Hood Assist  
 936 - Latch, Engine Access  
 Door  
 958 - Bracket, Sun Shade  
 Mounting  
 972 - Panel, Rear Trim  
 973 - Panel, Door Trim - Driver  
 Side  
 974 - Panel, Door Trim -  
 Passenger Side  
 975 - Holder, Cup  
 991 - Motor, Mirror  
 992 - Heater, Mirror  
 994 - Bracket, Mirror

## **GROUP 17 - WHEELS**

031 - Disc Wheel  
 087 - Hub (Disc Wheel)  
 108 - Rim (Demountable)  
 386 - Spoke Wheel

## **GROUP 18 – SCR AFTERTREATMENT**

045 - Hose, Pump to Tank  
 Supply / Suction  
 046 - Hose, Pump to Tank  
 Return  
 047 - Hose, Pump to Doser /  
 Injector  
 124 - Sensor Assembly, Def  
 Tank  
 177 - Cap, Filler Tank  
 180 - Cover, Supply Module  
 181 - Heater, Tank  
 350 - Hose, Tee to Doser  
 351 - Hose, Doser To Tee  
 500 - Bracket/Strap, Def Tank  
 501 - Bracket, Supply Module  
 Pump  
 502 - Bracket, ACM  
 565 - Wiring, (Sensor)  
 637 - Tank, Diesel Exhaust  
 Fluid  
 787 - Pickup, Tank  
 793 - Tank Def, Coolant Flow  
 Valve  
 801 - Module, PDM  
 906 - Wiring, ACM  
 907 - Wiring, Supply Module  
 908 - Wiring, Heated Line  
 909 - Wiring, Head Unit

## **GROUP 19 - ACCESSORIES**

001 - Fan, Defroster  
 015 - Clutch, Compressor  
 028 - Compressor/Reciprocating  
 029 - Compressor/Rotary  
 043 - Condenser  
 045 - Linkage, Wiper  
 070 - Switch, Radiator  
 Fan/Shutter Override  
 076 - Core (Heater)  
 094 - Evaporator  
 100 - Meter Assembly, Engine  
 105 - Wheel, Blower  
 138 - Block, Resistor  
 149 - Accumulator/Dryer  
 182 - Valve, Expansion  
 183 - Valve, Rear Expansion  
 187 - Ducting, Air  
 Cond/Heater/Defroster  
 197 - Horn Assembly  
 214 - Valve, Control  
 251 - Harness, Coiled Ribbon  
 (Clock Spring)  
 310 - A/C O Ring  
 317 - Schrader Valve, Low Side  
 318 - Schrader Valve, High Side  
 325 - Solenoid, Pneumatic  
 327 - Switch, Air Horns  
 331 - Electric Air Compressor,  
 Seat  
 343 - Shock, Seat  
 344 - Adjuster Assembly, Seat  
 351 - Frame, Seat  
 353 - Fitting  
 354 - Control, Air Seat  
 355 - Mounting/Housing (Main  
 Case)  
 363 - Bag, Air  
 381 - Retractor, Seat Belt  
 386 - Belt, Seat  
 411 - Plate, Fifth Wheel  
 417 - Control, Fifth Wheel

435 - Heater Assembly, Engine  
 436 - Socket, Engine Heater  
 443 - Back-Up Camera  
 472 - Reservoir  
 506 - Lock Cylinder, Fifth Wheel  
 632 - HVAC Hose, Under Cab to Rear  
 675 - Rest, Arm  
 708 - Module, Blower Speed LPM  
 709 - Module, HVAC Control  
 733 - Actuator, Motor/Door - Blend Air

734 - Actuator, Motor / Door – Fresh Air  
 735 - Actuator, Motor/Door - Air Distribution  
 763 - Sensor, Refrigerant Pressure  
 764 - Thermistor, Inlet  
 765 - Thermistor, Outlet  
 807 - Module, Vehicle Personality (VPM)  
 825 - Switch  
 826 - Switch, Bunk-On/Off  
 827 - Switch Bunk-Temperature Control

830 - Switch, Intermittent  
 837 - Switch, Clutch  
 838 - Switch, Set-Resume  
 849 - Module, Diagnostic - APADS  
 880 - Switch, Pressure-Low  
 881 - Switch, Pressure-High  
 882 - Switch, Thermostatic  
 885 - Freeze Sensor  
 909 - Harness, Cab (Wires, Connectors and Terminals)  
 923 - Harness, Front End (Wires/Connectors/Term)

## **GROUP 22 - GENESIS BODY - COMP**

001 - Fan, Defroster  
 040 - Bows  
 042 - Cowl, Front  
 044 - Frame, Rear  
 046 - Rails, Drip  
 048 - Rails, Seat  
 050 - Spacers, Bow  
 052 - Steps  
 055 - Bumper, Front  
 056 - Bumper, Rear  
 060 - Header, Entrance Door  
 061 - Frame, Entrance Door  
 062 - Drivers Seat Sub-Frame (K Frame)  
 063 - Frame, Side Emergency Door  
 064 - Frame, Rear Emergency Door  
 065 - Frame, Lift Door  
 066 - Frame, Body to Cab Floor  
 067 - Frame, Body to Cab Roof  
 068 - Frame, Davenport  
 080 - Bars, Light  
 082 - Bumpers, Header  
 084 - Caps, Inside  
 086 - Insulation  
 088 - Lining, Lower  
 090 - Lining, Overhead  
 092 - Racks, Luggage  
 094 - Rails Grab  
 096 - Rails, Shoulder  
 098 - Rails, Standee  
 100 - Reduction, Noise  
 120 - Bracket, License Plate  
 122 - Caps, Outside  
 124 - Caps, Post  
 126 - Door, Fuel  
 128 - Handles, Access  
 129 - Front Fiberglass Panel

130 - Panels, Rear Inside Window  
 131 - Front Sheet Metal  
 134 - Rails, Rub  
 136 - Rails, Snow  
 138 - Sheets, Side  
 140 - Skins, Rear Outside  
 141 - Hatch, Roof  
 142 - Skirts  
 146 - Roof Panels(Topping)  
 148 - Door, Engine  
 151 - Door, W/S Wiper  
 152 - Grille  
 200 - Electrical Access Compartment  
 204 - Battery, Compartment  
 208 - Spare Tire Compartment  
 212 - Luggage Compartment  
 214 - Safety Compartment  
 216 - Destination Sign Compartment  
 218 - Tool Compartment  
 239 - Controls Air  
 240 - Boxes, Buzzer  
 241 - Controls Electric  
 243 - Controls, Manual  
 244 - Devices, Hold Bac  
 246 - Doors, Entrance  
 248 - Doors, Lift – Single / Double  
 250 - Doors, Emer. Rear  
 252 - Doors, Emer. Side  
 254 - Handles, Door  
 256 - Hinges  
 258 - Locks, Door  
 262 - Vandallocks  
 275 - Light, Step  
 281 - Electric Panel  
 283 - Fuse Panel  
 284 - Horns

294 - Speakers  
 296 - Switches  
 297 - Radio  
 298 - Antenna  
 322 - Panels, Floor  
 326 - Sills, Floor  
 330 - Tiedown Bolts, Plates, J-Bolts, U-Bolts  
 332 - Wheel pocket Assy.  
 339 - Transition Panel / Cowl Filler Panel  
 340 - Doors, Engine Service  
 350 - Cross View Mirror  
 360 - Cover, Wheel-Pocket  
 364 - Moulding, Cove  
 366 - Treads, Step  
 369 - Wig-Wag  
 389 - Child Check Mate  
 402 - Window, Driver's  
 410 - Window, Emergency Exit  
 416 - Window, Split Sash  
 423 - Thermistor, Inlet  
 425 - Switch, Radiator Fan / Shutter Override  
 426 - Window, Split Storm  
 427 - Switch, Pressure - Low  
 429 - Clutch, Compressor  
 430 - A/C Compressor, Rotary  
 431 - Ducting, Air Conditioner  
 432 - Wheel, Blower  
 433 - Hose, A/C  
 434 - O-Ring, A/C  
 435 - Schrader Valve, Low Side  
 436 - Sensor, Refrigerant Pressure  
 437 - Switch  
 438 - Accumulator / Dryer  
 439 - Switch, Pressure - High  
 440 - Heater, Under Seat

441 - Harness, (Wires, Connectors, & Terminals)	471 - Harness, Power Distribution (On Flasher Plate)	544 - Red Light
442 - Heater, Rear	472 - Switch, Thermostatic	546 - Stop Light
444 - Covers/Trim, Hose	474 - Thermistor, Outlet	548 - Stop/Tail Light
445 - Control Cable	475 - Tube, Drain	550 - Strobe Light
446 - Driver's Heater	476 - Tube, Orifice	554 - Warning Light
447 - Core, Heater	478 - Motor	556 - Lift Door Light, Interior
449 - Motors, Heater	479 - A/C Electric Control Panel	558 - Lift Door Light, Exterior
450 - Stepwell Heater	480 - Panels, Modesty	560 - Cowl Mount Mirror
451 - Pump, Booster Heater	484 - Restraints, Lap	562 - Fender Mount Mirror / Rear View
453 - Condenser	488 - Stanchions	564 - Heated Mirror
454 - Fan, Condenser	493 - Harness, Left Hand Body	566 - Inside Rear View Mirror
455 - Evaporator	494 - Harness, Right Hand Body	568 - Spy Mirror
456 - Defroster Duct	495 - Harness, Flasher to Cowl	640 - Alarms, Backing
457 - Valve, Expansion	498 - Harness, Body Options External (Engine)	662 - Sign, Designation
459 - Fitting / Pipe (A/C)	499 - Microphone	682 - Crash Barrier Frame
460 - Harness, Front End	501 - Harness, Dash	684 - Belts, Seat
462 - Relay / Magnetic Switch	520 - Back-Up Light	692 - Passenger Seat Frame
463 - Schrader Valve, High Side	524 - Instrument Cluster Light	694 - Shields, Courtesy
464 - Harness, Flasher Plate	526 - Directional Light	697 - Flip Seat Frame
465 - Harness, LH Switch Panel	528 - Directional, Side Light Assembly	720 - Stop Arm
466 - Harness, Rh Switch Panel	534 - Fog Light	726 - Gates, Crossing
467 - Harness, Over Head Switch Panel	536 - Headlights	740 - Motor, Stop Arm
468 - Valve, Water (Dash Mounted A/C Heater Unit)	540 - License Plate Light, Assembly	742 - Motor, Stop Arm Module
469 - Harness, Front Cap	542 - Marker Light	762 - Static Vent
470 - Harness, Rear Cap		810 - Motor, Drive
		812 - Washer

## **WHAT IS NOT COVERED**

### **Components / Items:**

- Correction of loose fasteners, squeaks, rattles and unusual noises.
- Adjustments (e.g., headlights, brake/clutch adjustments, steering system adjustments, coolant levels).
- Items warranted by their respective manufacturers (e.g., non-Navistar brand engines, tires & tubes, Allison Transmissions, clutch, batteries, radios, lubricants, etc).
- Any part that is not a Navistar part number.
- Unauthorized parts other than Navistar service parts or ReNEWed® parts.
- Bodies, equipment and accessories installed by other than authorized Navistar employees at Navistar manufacturing plants.
- Front and rear axle alignment.
- Engine, Engine Electronics, Injectors, Turbocharger.
- Hybrid Electric Components (except Hybrid/Electric Drive Cooling).

### **Repairs:**

- Maintenance-related items/ repairs or those as a result of normal wear and tear, including tune-ups, brake/clutch lining, clutch brake, windshield wiper blades, windshield wiper nozzles, gaskets, belts, seals, tire balancing, lubrication, batteries and other similar procedures/parts required to keep vehicle in good working condition. Such maintenance items or repairs include, but are not limited to oil changes, oil filters, air filters, desiccant cartridge, fuel filters, tire rotation, cleaning/polishing, engine tune-up, adding oils, tightening of air intake and coolant clamps, ash tray, cigarette lighter element, fire extinguishers, fluorescent ballast and tubes, fuses, gladhand and gladhand rubbers, trailer hoses, hose tenders, trailer electrical cables, light bulbs, mattress, mud flaps, mud flap mounting bracket.



- Repairs to any part of the vehicle subjected to misuse, negligence, improper maintenance, improper operation, or which is the result of an accident.
- Fades, runs, mismatch or damage to paint, trim items, upholstery, chrome, polished surfaces, etc., resulting from environmental causes, improper polishes, cleaners or washing solutions, or chemical and industrial fallout.
- No coverage will be granted if Power Train, Propshaft and Suspension sales guidelines (specifications) are not strictly adhered to by all owners and operators of this vehicle.
- Accidents, acts of nature or other events beyond control of Navistar.
- Any single repair requiring less than \$40.00 parts and labor to complete.

**Other:**

- Vehicles sold and/or operated outside the United States or Canada.
- Vehicles/components which have had unauthorized alterations or modifications.
- Vehicles on which the odometer reading has been altered.
- Incidental or consequential costs or expenses which the owner may incur as a result of a malfunction or failure covered by this warranty, such as vehicle damage, communication expenses, meals, lodging, overtime, loss of use of engine or vehicle (“downtime”), loss of time, inconvenience, cargo loss or damage, and other similar costs and expenses.
- Replacement of defective parts, which were, not authorized Navistar equipment when first installed.
- Towing, unless additionally purchased.

**OBTAINING SERVICE**

To obtain service under this Service Contract, return this vehicle to any Navistar truck dealer authorized to service this model vehicle and engine. To locate an authorized dealer near you, please call the Navistar Customer Service Center at 800-44-TRUCK (800-448-7825).

**DISCLAIMER**

NO WARRANTIES ARE GIVEN BEYOND THOSE DESCRIBED HEREIN. THIS WARRANTY IS IN LIEU OF ALL OTHER WARRANTIES, EXPRESSED OR IMPLIED. THE COMPANY SPECIFICALLY DISCLAIMS WARRANTIES OF MERCHANTABILITY AND FITNESS FOR A PARTICULAR PURPOSE, ALL OTHER REPRESENTATIONS TO THE USER/PURCHASER, AND ALL OTHER OBLIGATIONS OR LIABILITIES. THE COMPANY FURTHER EXCLUDES LIABILITY FOR INCIDENTAL AND CONSEQUENTIAL DAMAGES, ON THE PART OF THE COMPANY OR SELLER. No person is authorized to give any other warranties or to assume any liabilities on the company’s behalf unless made or assumed in writing by the Company; and no other person is authorized to give any warranties or to assume any liabilities on the seller’s behalf unless made or assumed in writing by the seller.

**Remedies Under State or Provincial Law:** Some States and Provinces do not allow the exclusion or limitation of incidental or consequential damages, so the above limitation or exclusion may not apply to the owner. This warranty gives the owner specific legal rights, and he may also have other legal rights which may vary by state or province.

**Navistar, Inc., except in Canada where it is Navistar Canada, Inc.**

**TOW COVERAGE \$1,100 PER INCIDENT**

This service contract for **Towing option(s)** provides coverage for 24 months or unlimited miles/kilometers traveled from new vehicle delivery date, whichever expiration occurs first.

During this period, Navistar, Inc. ("Navistar") will pay for a service call and/or towing to the nearest IC Bus, International<sup>®</sup> or Cummins dealer WITH A NAVISTAR OR CUMMINS WARRANTABLE AND MISSION-DISABLING UNSAFE OPERATING CONDITION FAILURE. Coverage of Cummins failure begins AFTER the expiration of the Cummins second year of standard tow coverage for school bus if an additional Cummins service contract is active in Navistar Service Portal. Maximum liability for Navistar, per incident, is \$1,100. Exceptions are listed herein under section *What is Not Covered*.

**WHAT IS NOT COVERED****Repairs:**

- Towing in connection with a failure that is NOT warranted with Cummins or Navistar.
- Any expense over the \$1,100.00 maximum liability, per incident.

**Other:**

- Buses sold and/or operated outside the United States and Canada.
- Buses /components which have had unauthorized alterations or modifications.
- Buses on which the odometer reading has been altered.
- Loss of time or use of the bus, loss of profits, inconvenience, or other consequential or incidental damages or expenses.
- Incidental or consequential costs or expenses which the owner may incur as a result of a malfunction or failure covered by this warranty, such as vehicle damage, communication expenses, meals, lodging, overtime, loss of use of engine or vehicle ("downtime"), loss of time, inconvenience, cargo loss or damage, and other similar costs and expenses.

**OBTAINING SERVICE**

To obtain service under this Service Contract, return this vehicle to any IC Bus or International<sup>®</sup> truck dealer authorized to service this model bus and engine. To locate an authorized dealer near you, please call the Navistar Customer Service Center at 800-44-TRUCK (800-448-7825).

**DISCLAIMER**

FOLLOWING THE EXPIRATION OF THE STANDARD NAVISTAR LIMITED WARRANTY AND DURING THE PERIOD OF THIS SERVICE CONTRACT, NO WARRANTIES OR ADDITIONAL COVERAGE ARE GIVEN BEYOND THOSE DESCRIBED HEREIN. THIS EXTENDED WARRANTY IS IN LIEU OF ALL OTHER WARRANTIES, EXPRESSED OR IMPLIED, EXCEPT FOR THE APPLICABLE STANDARD NAVISTAR LIMITED WARRANTY FOR YOUR VEHICLE. NAVISTAR SPECIFICALLY DISCLAIMS WARRANTIES OF MERCHANTABILITY AND FITNESS FOR A PARTICULAR PURPOSE, ALL OTHER REPRESENTATIONS TO THE USER/PURCHASER, AND ALL OTHER OBLIGATIONS OR LIABILITIES. NAVISTAR FURTHER EXCLUDES LIABILITY FOR INCIDENTAL, SPECIAL, INDIRECT AND CONSEQUENTIAL DAMAGES, ON THE PART OF NAVISTAR OR SELLER. No person is authorized to give any other warranties or to assume any liabilities on Navistar's behalf unless specifically made or assumed in writing by Navistar; and no other person is authorized to give any warranties or to assume any liabilities on the seller's behalf unless specifically made or assumed in writing by the seller.

**Remedies Under State or Provincial Law:** Some States and Provinces do not allow the exclusion or limitation of incidental or consequential damages, so the above limitation or exclusion may not apply to the owner. This warranty gives the owner specific legal rights, and he may also have other legal rights which may vary by state or province.

**Navistar, Inc., except in Canada where it is Navistar Canada, Inc.**

# Request for Taxpayer Identification Number and Certification

**Give Form to the  
requester. Do not  
send to the IRS.**

▶ Go to [www.irs.gov/FormW9](http://www.irs.gov/FormW9) for instructions and the latest information.

Print or type.  
See Specific Instructions on page 3.

1 Name (as shown on your income tax return). Name is required on this line; do not leave this line blank. <b>LONGHORN BUS SALES, LLC</b>	
2 Business name/disregarded entity name, if different from above	
3 Check appropriate box for federal tax classification of the person whose name is entered on line 1. Check only <b>one</b> of the following seven boxes.  <input type="checkbox"/> Individual/sole proprietor or single-member LLC <input type="checkbox"/> C Corporation <input type="checkbox"/> S Corporation <input type="checkbox"/> Partnership <input type="checkbox"/> Trust/estate  <input checked="" type="checkbox"/> Limited liability company. Enter the tax classification (C=C corporation, S=S corporation, P=Partnership) ▶ <b>C</b> <b>Note:</b> Check the appropriate box in the line above for the tax classification of the single-member owner. Do not check LLC if the LLC is classified as a single-member LLC that is disregarded from the owner unless the owner of the LLC is another LLC that is <b>not</b> disregarded from the owner for U.S. federal tax purposes. Otherwise, a single-member LLC that is disregarded from the owner should check the appropriate box for the tax classification of its owner.  <input type="checkbox"/> Other (see instructions) ▶	4 Exemptions (codes apply only to certain entities, not individuals; see instructions on page 3):  Exempt payee code (if any) _____  Exemption from FATCA reporting code (if any) _____  <i>(Applies to accounts maintained outside the U.S.)</i>
5 Address (number, street, and apt. or suite no.) See instructions. <b>9100 NORTH LOOP EAST</b>	Requester's name and address (optional)
6 City, state, and ZIP code <b>HOUSTON, TEXAS 77029</b>	
7 List account number(s) here (optional)	

## Part I Taxpayer Identification Number (TIN)

Enter your TIN in the appropriate box. The TIN provided must match the name given on line 1 to avoid backup withholding. For individuals, this is generally your social security number (SSN). However, for a resident alien, sole proprietor, or disregarded entity, see the instructions for Part I, later. For other entities, it is your employer identification number (EIN). If you do not have a number, see *How to get a TIN*, later.

**Note:** If the account is in more than one name, see the instructions for line 1. Also see *What Name and Number To Give the Requester* for guidelines on whose number to enter.

<b>Social security number</b>									
<b>or</b>									
<b>Employer identification number</b>									
2	0	-	0	5	3	8	1	3	6

## Part II Certification

Under penalties of perjury, I certify that:

1. The number shown on this form is my correct taxpayer identification number (or I am waiting for a number to be issued to me); and
2. I am not subject to backup withholding because: (a) I am exempt from backup withholding, or (b) I have not been notified by the Internal Revenue Service (IRS) that I am subject to backup withholding as a result of a failure to report all interest or dividends, or (c) the IRS has notified me that I am no longer subject to backup withholding; and
3. I am a U.S. citizen or other U.S. person (defined below); and
4. The FATCA code(s) entered on this form (if any) indicating that I am exempt from FATCA reporting is correct.

**Certification instructions.** You must cross out item 2 above if you have been notified by the IRS that you are currently subject to backup withholding because you have failed to report all interest and dividends on your tax return. For real estate transactions, item 2 does not apply. For mortgage interest paid, acquisition or abandonment of secured property, cancellation of debt, contributions to an individual retirement arrangement (IRA), and generally, payments other than interest and dividends, you are not required to sign the certification, but you must provide your correct TIN. See the instructions for Part II, later.

<b>Sign Here</b>	Signature of U.S. person ▶	<i>Ashley Schrader</i>	Date ▶	<i>01/01/2022</i>
------------------	----------------------------	------------------------	--------	-------------------

## General Instructions

Section references are to the Internal Revenue Code unless otherwise noted.

**Future developments.** For the latest information about developments related to Form W-9 and its instructions, such as legislation enacted after they were published, go to [www.irs.gov/FormW9](http://www.irs.gov/FormW9).

### Purpose of Form

An individual or entity (Form W-9 requester) who is required to file an information return with the IRS must obtain your correct taxpayer identification number (TIN) which may be your social security number (SSN), individual taxpayer identification number (ITIN), adoption taxpayer identification number (ATIN), or employer identification number (EIN), to report on an information return the amount paid to you, or other amount reportable on an information return. Examples of information returns include, but are not limited to, the following.

- Form 1099-INT (interest earned or paid)

- Form 1099-DIV (dividends, including those from stocks or mutual funds)
- Form 1099-MISC (various types of income, prizes, awards, or gross proceeds)
- Form 1099-B (stock or mutual fund sales and certain other transactions by brokers)
- Form 1099-S (proceeds from real estate transactions)
- Form 1099-K (merchant card and third party network transactions)
- Form 1098 (home mortgage interest), 1098-E (student loan interest), 1098-T (tuition)
- Form 1099-C (canceled debt)
- Form 1099-A (acquisition or abandonment of secured property)

Use Form W-9 only if you are a U.S. person (including a resident alien), to provide your correct TIN.

*If you do not return Form W-9 to the requester with a TIN, you might be subject to backup withholding. See What is backup withholding, later.*



## 2500/2550 Series

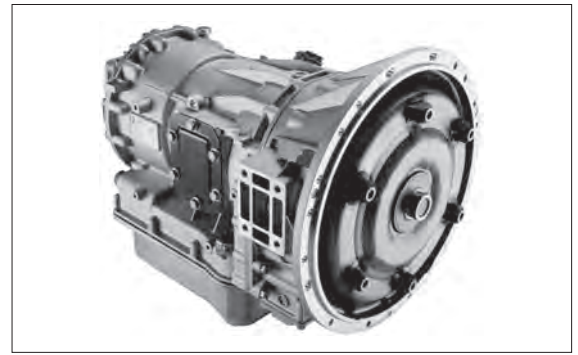

### RATINGS

Model <sup>(1)</sup>	Gross Input Torque <sup>(2)</sup> N•m	Gross Input Power <sup>(2)</sup> kW (hp)	Gross Input Torque <sup>(2)(3)</sup> N•m	Gross Input Power <sup>(2)(3)</sup> kW (hp)	GVW kg	GCW kg
2500 General	780	224 (300)	895	254 (340)	15,000	15,000
	746	224 (300)	766	224 (300)	12,000	12,000
	705	149 (200)	750	164 (220)	15,000	15,000
2500 MH Motorhome	746	224 (300)	895	254 (340)	15,000	15,000
2500 SP Specialty Vehicles	CONTACT YOUR ALLISON REPRESENTATIVE FOR DETAILS					
2550 General	780	224 (300)	895	224 (300)	13,600	13,600
	705	149 (200)	750	149 (200)	13,600	13,600
2550 SP Specialty Vehicles	CONTACT YOUR ALLISON REPRESENTATIVE FOR DETAILS					

(1). Models including vocational designations (ie: ORS, OF5, SP, MH) are for global markets. All other models within this document are targeted for outside North American markets only.  
 (2). Gross ratings as defined by ISO 1585 or SAE J1995. (3). Shift Energy Management (SEM) engine controls and torque limiting are required to obtain this rating.

### DRIVETRAIN INTERFACES

Acceptable full-load engine governed speed	2200 – 3800* rpm
Acceptable engine idle speed range (with transmission in Drive)	500 – 820 rpm
Maximum output shaft speed at 105 km/hr (65 mi/hr)	4500 rpm

\* Engines with full load governed speed greater than 3800 rpm require Application Engineering review

### MOUNTING

To Engine SAE No.3, SAE No.2

### TORQUE CONVERTER

Type One stage, three element, polyphase.  
Includes standard integral damper which is operational in lockup.

Model	Stall Torque Ratio
TC-210	2.05
TC-211	1.91
TC-221	1.73
TC-222	1.58

### MECHANICAL RATIOS (Gear ratios do not include torque converter multiplication)

Range	
First	3.51 : 1
Second	1.90 : 1
Third	1.44 : 1
Fourth	1.00 : 1
Fifth	0.74 : 1
Sixth	0.64 : 1
Reverse	-5.09 : 1

### CONTROL SYSTEM

Description Allison 5th Generation Electronic Controls with closed loop adaptive shifts

Shift Sequences [C = Converter mode (lockup clutch disengaged); L = Lockup mode (lockup clutch engaged)]

Option 1: 1C-[1L]-2C-2L-3L-4L-5L

Option 2: 1C-[1L]-2C-2L-3L-4L-5L-6L

Driver-to-Transmission Interface

Cab-mounted shift selector

Communication Protocol - Engine/Vehicle Systems Interface

SAE J1939, IESCAN, PT-CAN

**PHYSICAL DESCRIPTION**

	Installation Length*	Dry Weight	Depth below transmission centerline	
			With Shallow Oil Sump	With Deep Oil Sump
SAE No.3	729 mm	150 kg	272 mm	285 mm
SAE No.2	739 mm	150 kg	272 mm	285 mm

\*Approximate length from engine housing to output flange (depending on output flange type)

**TURBINE-DRIVEN POWER TAKE-OFF PROVISION**

PTO drive	Torque converter turbine-driven spur gear
PTO mounting pads	Six-bolt, 3 o'clock and 9 o'clock positions (as viewed from rear)
PTO drive gear rating (continuous operation)	Using one PTO: 339 N•m Total using two PTO's: 271 N•m
PTO drive gear ratio	1.00 x turbine speed
PTO drive gear	64 tooth

**OIL SYSTEM**

Allison approved fluids: TES 295 and TES 389

Capacity, excluding external circuits

With Deep Oil Pan 14 litres

With Shallow Oil Pan 12 litres

Spin on canister filter Standard

**SPEEDOMETER PROVISION**

Description	Non-zero-crossing square wave
Location	8, 16 or 40 pulses per revolution of transmission output shaft Electronic output from TCM

**TACHOGRAPH PROVISION**

Tone wheel	6-tooth
Mounting Location	M18 x 1.5 metric thread Transmission rear cover

**2500/2550 Series**

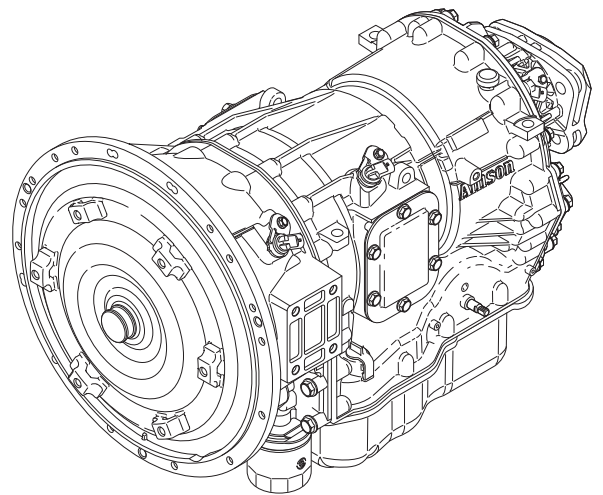
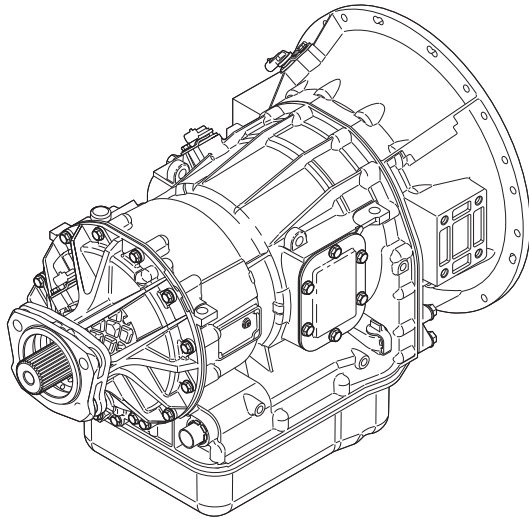



All IC School Buses come with: PROMOTIONAL PACKAGE 84 Month Unlimited Miles/km Warranty, Limited Time Program for Allison 2000 Series Transmission (Supplied directly through Allison)

Allison 3000 Series Transmission 60 Month Unlimited Miles/km Warranty (Supplied directly through Allison)

# Cummins Warranty

**All Engines United States And Canada School Bus**

## Coverage

### Products Warranted

This Warranty applies to new diesel, LPG, compressed or liquid natural gas fueled Engines sold by Cummins Inc. or Cummins Westport and delivered to the first user on or after September 15, 1996, that are used in school bus\* applications in the United States\*\* or Canada.

### Base Engine Warranty

The Base Engine Warranty covers any failures of the Engine which result, under normal use and service, from a defect in material or factory workmanship (Warrantable Failure). This Coverage begins with the sale of the Engine by Cummins and continues for five years or 100,000 miles (160,934 kilometers), whichever occurs first, from the date of delivery of the Engine to the first user.

Engine aftertreatment components included in the Cummins Critical Parts List (CPL) and marked with a Cummins part number are covered under Base Engine Warranty.

### Extended Major Components Warranty

The Extended Major Components Warranty applies to all except ISV, ISB6.7 G, B and ISB Series Engines and covers Warrantable Failures of the Engine cylinder block, camshaft, crankshaft and connecting rods (Covered Parts).

Bushing and bearing failures are not covered.

This Coverage begins with the expiration of the Base Engine Warranty and ends three years or 300,000 miles (482,804 kilometers), whichever occurs first, from the date of delivery of the Engine to the first user.

### Emission Warranty

Additional Coverage is outlined under the Emission Warranty.

**THESE WARRANTIES ARE MADE TO ALL OWNERS IN THE CHAIN OF DISTRIBUTION AND COVERAGE CONTINUES TO ALL SUBSEQUENT OWNERS UNTIL THE END OF THE PERIODS OF COVERAGE.**

## Cummins Responsibilities

### During The Base Engine Warranty

Cummins will pay for all parts and labor needed to repair the damage to the Engine resulting from a Warrantable Failure.

Cummins will pay for the lubricating oil, antifreeze, filter elements, belts, hoses and other maintenance items that are not reusable due to the Warrantable Failure.

Cummins will pay for reasonable labor costs for Engine removal and reinstallation when necessary to repair a Warrantable Failure.

Cummins will pay reasonable costs for towing a vehicle disabled by a Warrantable Failure to the nearest

authorized repair location when necessary to make the repair for the first 2 years from the date of delivery of the Engine to the first user. In lieu of towing expenses, Cummins will pay reasonable costs for mechanics to travel to and from the location of the vehicle, including meals, mileage and lodging, when the repair is performed at the site of the failure.

### During The Extended Major Components Warranty

Cummins will pay for the repair or, at its option, replacement of the defective Covered Part and any Covered Part damaged by a Warrantable Failure of the defective Covered Part.

## Owner Responsibilities

### During The Base Engine Warranty

Owner is responsible for the cost of lubricating oil, antifreeze, filter elements and other maintenance items provided during Warranty repairs unless such items are not reusable due to the Warrantable Failure.

### During The Extended Major Components Warranty

Owner is responsible for the cost of all labor needed to repair the Engine, including the labor to remove and reinstall the Engine. When Cummins elects to repair a part instead of replacing it, Owner is not responsible for the labor needed to repair the part.

Owner is responsible for the cost of all parts required for the repair except for the defective Covered Part and any Covered Part damaged by a Warrantable Failure of the defective Covered Part.

Owner is responsible for the cost of lubricating oil, antifreeze, filter elements and other maintenance items replaced during the repair.

### During The Base Engine And Extended Major Components Warranties

Owner is responsible for the operation and maintenance of the Engine as specified in the applicable Cummins Operation and Maintenance Manual. Owner is also responsible for providing proof that all recommended maintenance has been performed.

Before the expiration of the applicable Warranty, Owner must notify a Cummins distributor, authorized dealer or other repair location approved by Cummins of any Warrantable Failure and make the Engine available for repair by such facility. Except for Engines disabled by a Warrantable Failure during the first two years from the date of delivery of the Engine to the first user, Owner must also deliver the Engine to the repair facility.

Service locations are listed on the Cummins Worldwide Service Locator at [cummins.com](http://cummins.com).

Owner is responsible for communication expenses, meals, lodging and similar costs incurred as a result of a Warrantable Failure.

Owner is responsible for non-Engine repairs and for "downtime" expenses, passenger delays, fines, all applicable taxes, all business costs and other losses resulting from a Warrantable Failure.

## Limitations

Engines with an emissions certification listed below must be operated using only diesel fuel having no more than the corresponding maximum sulfur content. Failure to use the specified fuel as listed in the Cummins Fuel Bulletin #3379001 Table 1 (Cummins Inc. Required Diesel Fuel Specifications) can damage the Engine and aftertreatment system within a short period of time. This damage could cause the Engine to become inoperable and failures attributable to the use of incorrect fuels will be denied Warranty Coverage. Fuel specifications also need to comply with local fuel regulations (EN590 for Europe and ASTM D975 for North America) for Warranty eligibility.

### Maximum sulfur levels by emissions certification level as listed on the Engine's dataplate are:

EPA 2007/2010/2013/2017/2021	max. 15 parts per million
EPA Tier 4 Interim / Final / Stage V in North America	max. 15 parts per million
EU Stage IIIB 2011	max. 15 parts per million
EU Stage IV 2011	max. 15 parts per million
EU Stage V	max. 10 parts per million
Euro 4/5	max. 50 parts per million
Euro 6	max. 10 parts per million

Cummins is not responsible for failures or damage resulting from what Cummins determines to be abuse or neglect, including, but not limited to: operation without adequate coolants or lubricants; overfueling; overspeeding; lack of maintenance of lubricating, cooling or intake systems; improper storage, starting, warm-up, run-in or shutdown practices; unauthorized modifications of the Engine.

Any unauthorized modifications to the aftertreatment system could negatively affect emissions certification and void the Warranty.

Cummins is also not responsible for failures caused by incorrect oil, fuel or diesel exhaust fluid or by water, dirt or other contaminants in the fuel, oil or diesel exhaust fluid.

Alternators and starters are covered for the first two years from the date of delivery of the Engine to the first user, or the expiration of the Base Engine Warranty, whichever occurs first.

Excessive oil consumption for ISV and B Series Engines is covered for the duration of the Coverage. Before a claim for excessive oil consumption will be considered, Owner must submit adequate documentation to show that consumption exceeds Cummins published standards.

Failures of belts and hoses supplied by Cummins are not covered beyond the first year from the date of delivery of the Engine to the first user or the expiration of the applicable Base Engine Warranty, whichever occurs first.

Parts used to repair a Warrantable Failure may be new Cummins parts, Cummins approved rebuilt parts or repaired parts. Cummins is not responsible for failures resulting from the use of parts not approved by Cummins.

A new Cummins or Cummins approved rebuilt part used to repair a Warrantable Failure assumes the identity of the part it replaced and is entitled to the remaining Coverage hereunder.

Cummins, Inc. reserves the right to interrogate Electronic Control Module (ECM) data for purposes of failure analysis.

### **CUMMINS DOES NOT COVER WEAR OR WEAROUT OF COVERED PARTS.**

### **CUMMINS IS NOT RESPONSIBLE FOR INCIDENTAL OR CONSEQUENTIAL DAMAGES.**

**THESE WARRANTIES AND THE EMISSION WARRANTY SET FORTH HEREINAFTER ARE THE SOLE WARRANTIES MADE BY CUMMINS IN REGARD TO THESE ENGINES. CUMMINS MAKES NO OTHER WARRANTIES, EXPRESS OR IMPLIED, OR OF MERCHANTABILITY OR FITNESS FOR A PARTICULAR PURPOSE.**

This Warranty gives you specific legal rights, and you may also have other rights which vary from state to state.

## Emission Warranty

### Products Warranted

This Emission Warranty applies to new Engines marketed by Cummins that are used in the United States\*\* or Canada in vehicles designed for transporting persons or property on a street or highway. This Warranty applies to Engines delivered to the ultimate purchaser on or after January 1, 1996.

### Coverage

Cummins warrants to the ultimate purchaser and each subsequent purchaser that the Engine is designed, built and equipped so as to conform at the time of sale by Cummins with all U.S. federal emission regulations applicable at the time of manufacture and that it is free from defects in material or factory workmanship which would cause it not to meet these regulations within the longer of the following periods: (A) Five years or 100,000 miles (160,934 kilometers) of operation, whichever occurs first, as measured from the date of delivery of the Engine to the ultimate purchaser, or (B) The Base Engine Warranty.

If the vehicle in which the Engine is installed is registered in the state of California, a separate California Emission Warranty also applies.

## Limitations

Engines with an emissions certification listed below must be operated using only diesel fuel having no more than the corresponding maximum sulfur content. Failure to use the specified fuel as listed in the Cummins Fuel Bulletin #3379001 Table 1 (Cummins Inc. Required Diesel Fuel Specifications) can damage the engine and aftertreatment system within a short period of time. This damage could cause the engine to become inoperable and failures attributable to the use of incorrect fuels will be denied Warranty Coverage. Fuel specifications also need to comply with local fuel regulations (EN590 for Europe and ASTM D975 for North America) for Warranty eligibility.

### Maximum sulfur levels by emissions certification level as listed on the Engine's dataplate are:

EPA 2007/2010/2013/2017/2021	max. 15 parts per million
EPA Tier 4 Interim / Final / Stage V in North America	max. 15 parts per million
EU Stage IIIB 2011	max. 15 parts per million
EU Stage IV 2011	max. 15 parts per million
EU Stage V	max. 10 parts per million
Euro 4/5	max. 50 parts per million
Euro 6	max. 10 parts per million

Failures, other than those resulting from defects in material or factory workmanship, are not covered by this Warranty.

Cummins is not responsible for failures or damage resulting from what Cummins determines to be abuse or neglect, including, but not limited to: operation without adequate coolants or lubricants; overfueling; overspeeding; lack of maintenance of lubricating, cooling or intake systems; improper storage, starting, warm-up, run-in or shutdown practices; unauthorized modifications of the Engine.

Any unauthorized modifications to the aftertreatment system could negatively affect emissions certification and void the Warranty.

Cummins is also not responsible for failures caused by incorrect oil, fuel or diesel exhaust fluid or by water, dirt or other contaminants in the fuel, oil or diesel exhaust fluid.

Cummins is not responsible for non-Engine repairs, "downtime" expenses, cargo damage, fines, all applicable taxes, all business costs or other losses resulting from a Warrantable Failure.

### CUMMINS IS NOT RESPONSIBLE FOR INCIDENTAL OR CONSEQUENTIAL DAMAGES.

\* A vehicle used to transport students to and from school. Vehicle must be painted yellow, should have warning lights and the words 'SCHOOL BUS' written on the front

and rear roof caps. The requirements pertaining to paint color, warning lights and 'SCHOOL BUS' inscription would not apply if the vehicle is exclusively used to transport students for school related activities and it is owned by a school district.

\*\* United States includes American Samoa, the Commonwealth of Northern Mariana Islands, Guam, Puerto Rico and the U.S. Virgin Islands.



Cummins Inc.  
Box 3005  
Columbus, IN 47202-3005  
U.S.A.

Bulletin No. 3381329  
Printed in U.S.A. Rev 3/20  
©1999 Cummins Inc.

# B6.7™

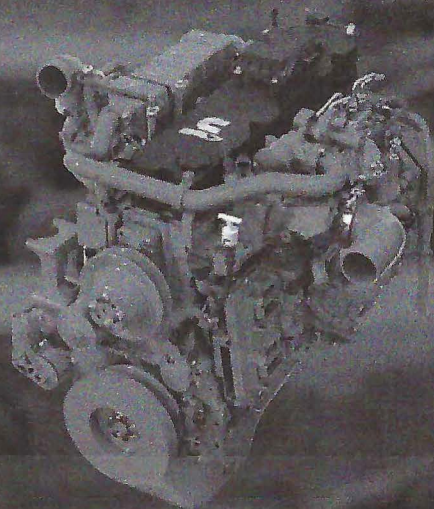

## PROVEN TRACK RECORD

The Cummins B6.7™ is one of the most dependable, durable and reliable medium-duty engines available. It's been tested and proven with more than 12 million engines produced over nearly 40 years, with billions of miles driven. These figures aren't just milestones either. They represent years of experience learning and optimizing the product into what we produce today – the most reliable B6.7 Cummins has ever built. We're proud of this history and proud that Cummins medium-duty products power more school buses in operation across North America than any other engines.

## REDUCED OPERATING COSTS

We know total cost of operation (TCO) is important to our customers, which is why we focused on making enhancements to reliability and durability while also lowering the TCO. New for EPA 2021, the B6.7 features upgrades that allow for extended engine maintenance intervals, including longer oil drain intervals, more time between fuel filter changes and a completely maintenance-free crankcase ventilation filter. Also new for 2021, the B6.7 offers advancements in connectivity to find, prevent and resolve issues faster.

## WE HAVE YOUR BACK

The B6.7 comes with a 5-year / 100,000-mile base warranty. For added peace of mind, we offer multiple extended coverage plan options up to 10 years, designed to provide you with the coverage you need for your operation. All Cummins products are backed by the largest, most capable support network in North America. With over 3,700 certified repair locations across the U.S. and Canada, your school buses are never far from a Cummins-certified technician.

## B6.7 MAINTENANCE INTERVALS

Maintenance Item	Miles/ Kilometers	Hours	Months
*Oil and Filter	30,000 mi/48,000 km	1,000	18
Fuel Filter	60,000 mi/96,000 km	2,000	18
Overhead Adjustment	150,000 mi/240,000 km	5,000	48
Coolant Check	15,000 mi 24,000 km	500	6
DEF Filter	200,000 mi 320,000 km	6,500	N/A
Particulate Filter Cleaning	200,000 mi 320,000 km	6,500	N/A
Crankcase Ventilation Filter	N/A	N/A	N/A

\* With a 19-quart oil pan. Duty-cycle dependent.

Consult your Operation and Maintenance Manual for more information.

## B6.7 SCHOOL BUS RATINGS

Engine Model	Advertised HP (kW)	Peak Torque LB-FT (N•m) @ RPM	Governed Speed
B6.7 260	260 (194)	660 (896) @ 1600	2600
B6.7 250	250 (187)	660 (896) @ 1600	2600
B6.7 240	240 (179)	560 (760) @ 1600	2600
B6.7 220	220 (164)	600 (814) @ 1600	2600
B6.7 220	220 (164)	520 (206) @ 1600	2600
B6.7 200	200 (149)	520 (206) @ 1600	2600

# OVER THE AIR PROGRAMMING CAPABILITY.

When connected to a compatible and participating telematics system, Cummins Connected Software Updates facilitate engine control module calibrations remotely in about five minutes, which slashes downtime by eliminating a traditionally scheduled visit to the service bay. Once Cummins Connected Software Updates have been integrated, customers can leverage the same technology to take advantage of Cummins full upcoming suite of over-the-air programming solutions designed to enhance performance, safety and fuel efficiency.

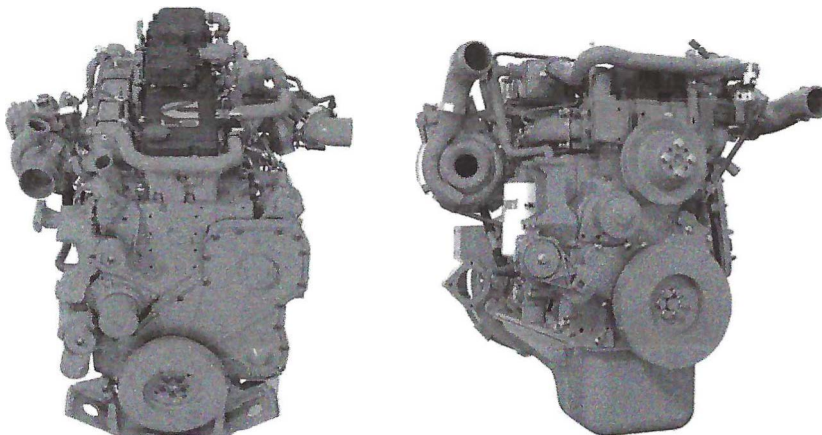

Cummins Inc.  
Box 3005  
Columbus, IN 47202-3005  
U.S.A.

1-800-CUMMINS™ (1-800-286-6467)  
cummins.com

Bulletin 5544101 Printed in U.S.A. Rev. 9/20  
©2020 Cummins Inc.



# Bendix® Wingman® Advanced™

A Collision Mitigation Technology



Bendix



A powerful combination of collision mitigation and full stability technologies

**WINGMAN**  
Advanced



## The Key is Active Braking

The Bendix® Wingman® Advanced™ system is the latest innovation for school buses from the industry leader in active braking technologies – Bendix Commercial Vehicle Systems. Bendix Wingman Advanced brings together adaptive cruise control with braking features along with collision mitigation technology, and our full-stability technology – Bendix® ESP® – providing your fleet with a system that can help. Your fleet benefits from a potent combination of active safety technologies that can help your drivers in collisions, roll-overs, and loss-of-control situations. In addition, the system can provide data, to help keep you in the know about what's happening out on the road.

### Helping your drivers on the roadway

When the distance between your driver's bus and the vehicle they're following starts to close, Bendix Wingman Advanced provides the driver following distance alerts and, if necessary, will apply the brakes to help the driver potentially avoid the collision, or help reduce its severity.

Bendix Wingman Advanced features stationary object alerts. These alerts give the driver a warning (up to 3.0 seconds) of a metallic object, such as a stalled car, blocking the lane of travel.

### Providing information you can use

Performance on the road is important, but you also need actionable information to know what's happening out there. The Bendix Wingman Advanced system can deliver important data your school bus fleet can use, such as following distance information, alerts given, and stability events. Knowing about close calls and other insights from the road can help you assess and update your driver training needs and support fleet operations.

### Making a positive contribution to your bottom line

It's all about getting a quick return on your safety investment. The Bendix Wingman Advanced system helps your fleet in multiple ways. By helping drivers potentially avoid rear-end collisions or, at least, help reduce their severity, your fleet may see fewer accidents and less accident-related costs. Also, a number of alerts will now be available to drivers to help them on their daily routes, such as an impact alert, stationary object alert, and following distance alerts, which should increase safety and reduce accident-related costs.

## Bendix® Wingman® Advanced™ Features

### Alerts (are always available whether cruise control is engaged or not)

- *Following Distance Alerts* – audible and visual alerts which let drivers know when getting too close to a forward vehicle ✓
- *Impact Alerts* – audible and visual alerts warning the driver that a collision with the forward vehicle is likely and that they should address the situation immediately ✓
- *Stationary Object Alerts* – audible and visual alerts that provide the driver up to a 3.0 second alert when a metallic object(s) may be blocking the lane of travel ✓

### Adaptive Cruise Control with Braking (functions when cruise control is on and speed is set)

- Reduces throttle to help the driver maintain a set following distance behind a forward vehicle ✓
- Engages the engine retarder to help the driver maintain a set following distance behind a forward vehicle ✓
- Applies the foundation brakes to help the driver maintain a set following distance behind a forward vehicle ✓

### Electronic Stability System

- Bendix® ESP® full stability system to help drivers mitigate rollovers and loss-of-control situations on wet and dry roadways ✓

### Collision Mitigation (functions whether or not cruise control is on and speed is set)

- Provides audible and visual alerts to the driver and applies the brakes when the system determines a collision with a forward vehicle is imminent ✓



## The Bendix Wingman Advanced system doesn't replace the need for safe drivers

*No school bus safety technology replaces the most important safety components of all – a skilled, alert professional driver exercising safe driving habits, as well as continuous, comprehensive driver training. Responsibility for the safe operation of the vehicle remains with the driver at all times.*

Warranty Coverage 36 Months, 350,000 Miles

# The Key is Active Braking



## Help your drivers & your students everywhere, every day...

*The Bendix® Wingman® Advanced™ system:*

### **Provides more control on slick surfaces;**

Apply the brakes automatically on a slick or icy roadway and the risk of losing control increases. Bendix Wingman Advanced is built on the Bendix® ESP® full stability system. Full stability does more than roll-only systems to help keep school buses under control when brakes are automatically applied on slick surfaces.

### **Delivers more braking power when your drivers need it;**

Bendix Wingman Advanced delivers up to 2/3 (67%) of vehicle braking power. By building on a full-stability platform, all brakes – steer & drive – are available and can be controlled as necessary to provide maximum braking power and a more even braking distribution.

### **Less wear and tear on your brakes which equals lower maintenance costs, less vehicle downtime;**

The adaptive cruise control with braking feature of Bendix Wingman Advanced helps your drivers keep a set following distance by reducing throttle, engaging the engine retarder or, if necessary, applying the brakes. This progressive approach means brakes only get used when they're really needed resulting in less brake wear and more savings.

### **Delivers "Always Available" driver alerts;**

As following distance closes, drivers receive unique visual and audible warnings to aid their response. Fewer false warnings means drivers react when the system alerts.

### **Alerts drivers to stationary road hazards;**

Stationary object alert can provide drivers with an extra warning about metallic objects such as standing vehicles blocking their lane of travel day or night, rain or shine, fog or snow.

### **Provides useful information; and**

Delivers valuable data about following distance, alerts, and stability interventions that you can use to help target driver training needs.

### **Cost justified, proven safety.**

Potentially avoiding a collision or reducing the severity of just one crash can add up to substantial savings from accident and other related costs. With young lives at stake, safety for students is always a number one priority.

**For complete details about the Bendix® Wingman® Advanced™ system, contact your Bendix Account Manager, call 1-800-AIR-BRAKE (1-800-247-2725), or visit [bendix.com](http://bendix.com) today.**

### **Bendix® ESP® stability for added protection and performance**

Bendix ESP, with over 600,000 systems delivered, is an integral part of the Bendix Wingman Advanced system, helping your drivers mitigate roll-over and loss-of-control situations on dry, wet, snow and ice-covered pavement. Plus, Bendix ESP helps Bendix Wingman Advanced use more brakes on the vehicle to deliver more braking power and better balanced brake applications.



**IC Bus Servicing Dealers**

International Dealer	Address	Phone
Border International Trucks El Paso	12283 Rojas Dr, El Paso, TX 79936	(915) 858-4644
Graham International Inc Sherman	5800 Texoma Pkwy, Sherman, TX 75090	(903) 892-2122
Graham International, Inc. Paris	2945 NE Loop 286, Paris, TX 75460	(903) 784-6683
Kyrish Truck Center of Houston	14201 Hempstead Rd, Houston, TX 77040	(713) 690-1700
Kyrish Truck Center of Houston	8900 N Loop E Fwy, Houston, TX 77029	(713) 674-3444
Kyrish Truck Center of Pharr	711 N Cage Blvd, Pharr, TX 78577	(956) 961-4681
Kyrish Truck Center of Victoria	2605 Port Lavaca Dr, Victoria, TX 77901	(361) 575-1481
Kyrish Truck Centers of Austin North	16336 N. Interstate 35, Austin, TX 78728	(512) 813-6868
Kyrish Truck Centers of Austin South	5010 Burleson Rd, Austin, TX 78744	(512) 389-1111
Kyrish Truck Centers of Beaumont	2465 W Cardinal Dr, Beaumont, TX 77705, USA	(409) 617-0975
Kyrish Truck Centers of Bryan	4050 Hwy 21 East, Bryan, TX 77808	(979) 778-7481
Kyrish Truck Centers of Corpus Christi	7749, I-37, Corpus Christi, TX 78409	(361) 289-5151
Kyrish Truck Centers of Temple	6043 N General Bruce Dr., Temple, TX 76501	(254) 778-3648
Kyrish Trucks Centers of San Antonio, TX	1380 Ackerman Rd, San Antonio, TX 78219	(210) 661-8371
Longhorn Bus Sales	9100 N Loop E Fwy, Houston, TX 77029	(713) 631-9306
Longhorn Bus Sales South	221 W Expy 83, La Feria, TX 78559	(956) 797-3006
Pliier International	3016 S Eastman Rd, Longview, TX 75602	(903) 758-3351
Price International Trucks Tyler	5033 HIGHWAY 271 N, Tyler, TX 75708	(903) 225-4042
Roberts Truck Center Amarillo	4378 Canyon Dr, Amarillo, TX 79109	(806) 355-9771
Roberts Truck Center Lubbock	4510 Avenue A, Lubbock, TX 79404	(806) 763-8213
Roberts Truck Center Midland	10101 I-20 Frontage, Midland, TX 79706	(432) 697-2241
Roberts Truck Center San Angelo	617 N Bell St, San Angelo, TX 76903	(325) 655-7187
Roberts Truck Center Tye	550 S Access Rd, Tye, TX 79563	(325) 677-3393
Rotex Truck Center Lerado	11802 Sara Rd, Laredo, TX 78045	(956) 722-1250
Southwest International Trucks Arlington	2401 E Pioneer Pkwy, Arlington, TX 76010	(817) 664-2900
Southwest International Trucks Fort Worth	617 North Fwy, Fort Worth, TX 76102	(817) 336-4651
Southwest International Trucks McKinney	2105 N Central Expy, McKinney, TX 75070	(972) 629-3600
Southwest International Trucks Waco	3920 N Interstate 35 Frontage Rd South, Waco, TX 76706	(254) 340-6700
Southwest International Trucks, Inc.	3722 Irving Blvd, Dallas, TX 75247	(214) 689-1400
Summit Truck Group Wichita Falls	2401 Central E Fwy, Wichita Falls, TX 76302	(940) 322-7845

### IC Bus Servicing Dealers

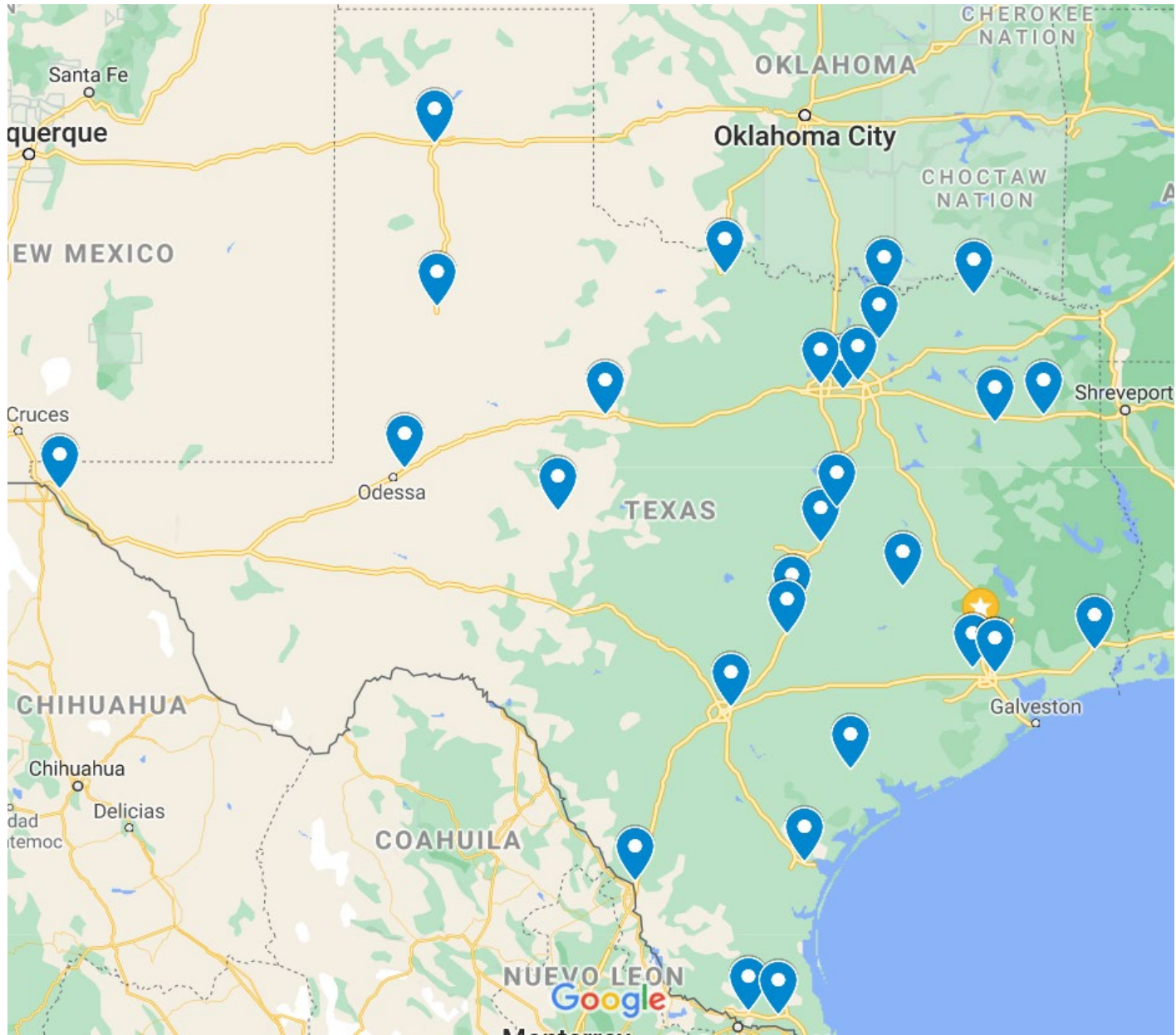

# Medina Valley Independent School District

## *Agenda Item Memorandum*

*To: MVISD Board of Trustees*

*Date: 9-19-2022*

*RE: Consider approving contract for construction of tennis courts at Loma Alta Middle School*

Consider approving the contract with Hellas Construction, Inc. for construction of tennis courts at Loma Alta Middle School (details in the Hellas contract).



September 16, 2022

Dr. Scott Caloss – Superintendent of schools  
Medina Valley ISD  
FM 471 South, Castroville, TX 78009  
[Scott.caloss@mvisd.org](mailto:Scott.caloss@mvisd.org)

RE: Medina Valley ISD – Loma Alta Middle School  
Tennis Surfacing Proposal

**Hellas Construction, Inc.** is pleased to provide you with this proposal. The proposal is based on Hellas' available cooperative contracts. Through these contracts, Hellas' products and services have been competitively and lawfully bid providing member schools and agencies with quality and preferential pre-priced products and services.

### **General Conditions**

**Hellas** will:

1. Provide project Insurance, Supervision and Mobilization.
2. Provide performance and payment bonds.
3. Provide, prior to construction, all required submittals.
4. Provide final punch-out and clean-up of the completed project.

### **PROPOSAL 1 - TENNIS COURTS SURFACING**

#### **Existing Conditions**

**Hellas** scope of work:

1. Removal of four (4) basketball hoops. Dispose two (2) of them.
2. Removal and disposal of existing fence as required.

#### **Fence**

**Hellas** scope of work:

1. Furnish and install approximately 456 linear feet of 10' tall black vinyl coated chain link fence including two (2) 3' wide x 10' tall black vinyl pedestrian gates including 9' high windscreen (no logos, no letterings).

#### **Athletic Equipment**

**Hellas** will:

1. Furnish and install two (2) sets of 3" Edwards Classic Net Posts and Nets.
2. Relocate two (2) of the existing basketball hoops at the west side of the courts.





### **Tennis Court Surfacing (13,382 SF)**

**Hellas** will:

1. Clean off existing basketball courts with a pressure washer and blower to remove all dirt from existing courts. All bird baths will be patched with TPS 5000® Rhinofill crack filler.
  2. Apply one (1) coat of TPS 5000® Acrylic Surface at a rate of 0.7 gal/SY. Silica sand shall be mixed to achieve a medium to slow ball speed.
  3. Apply two (2) coats of TPS 5000® Fortified Acrylic Color Coating.
  4. Layout and paint 2" wide lines using Line Tape Sealer as a primer coat to ensure razor sharp edges. Paint shall be TPS 5000® White Line Paint and painted in accordance to USTA specifications.
  5. Layout and paint 2" wide lines for the new two (2) basketball free throw areas at west side of the courts.
- 

### **BASE PROPOSAL 2 – NEW TENNIS COURTS CONSTRUCTION**

#### ***Existing Conditions and Sitework***

**Hellas** scope of work:

1. Construct one (1) construction entrance.
2. Excavation to subgrade. Excavated materials will be disposed off site.
3. Remove concrete pads next to the new tennis courts ± 220 square feet.

#### ***Subgrade***

**Hellas** scope of work:

1. Follow recommendations per Geotechnical evaluation report by ECS Southwest, LLP (Project 20:1424) to achieve 1" PVR.

#### ***Fence***

**Hellas** scope of work:

1. Furnish and install approximately 456 linear feet of 10' tall black vinyl coated chain link fence including two (2) 3' wide x 10' tall black vinyl pedestrian gates including 9' high windscreen (no logos, no letterings).

#### ***Post Tensioned Slab***

**Hellas** will:

1. Provide and place 2" of fines for a leveling course.
2. Provide and place 10mil vapor barrier.
3. Construct approximately 13,382 square feet of post tensioned slab, with tendon spacing per engineering.



**Athletic Equipment**

Hellas will:

1. Furnish and install two (2) sets of 3” Edwards Classic Net Posts and Nets.

**Tennis Court Surfacing (13,382 SF)**

Hellas will:

1. Clean off each court with a pressure washer and blower to remove all dirt and debris and acid wash the new concrete surface. All bird baths will be patched with TPS 5000® Rhinofill crack filler.
2. Apply one (1) coat of TPS 5000® Acrylic Surface at a rate of 0.7 gal/SY. Silica sand shall be mixed to achieve a medium to slow ball speed.
3. Apply two (2) coats of TPS 5000® Fortified Acrylic Color Coating.
4. Layout and paint 2” wide lines using Line Tape Sealer as a primer coat to ensure razor sharp edges. Paint shall be TPS 5000® White Line Paint and painted in accordance to USTA specifications.

---

**PROPOSAL PRICES**

1.	Tennis Courts Surfacing	\$ 120,400.00
2.	New Tennis Courts Construction	\$ 484,900.00
<b>3.</b>	<b>BASE BID TOTAL</b>	<b>\$ 605,300.00</b>

---

**PROPOSAL 2 ALTERNATE**

1. Add alternate to provide and install New Cooper LED lighting 50 footcandles. Add to base proposal.  
Add alternate 1 Amount \$170,000.00
- 

**EXCLUSIONS**

1. Any item of work not specifically listed above.
2. Rock excavation or haul off.
3. Any concrete work out of the scope of this proposal.
4. Any asphalt paving or repair.
5. Construction materials inspection and testing.
6. Supply or installation of perimeter safety or construction fencing.
7. Site security.
8. Any Allowances or Contingencies.
9. Taxes.



10. Prevailing or union wages.
11. Owner shall provide ingress/egress for ALL personnel, equipment and materials; typical construction traffic shall be expected for the duration of this contract. Contractor NOT responsible for damage due to typical construction traffic ingress/egress to the construction site.
12. Owner to supply secure laydown area for Hellas materials.

Notwithstanding anything to the contrary in any of the Contract documents, under no circumstances shall the Performance bonds, maintenance bonds or the obligations of the Surety be liable for any warranty obligations that exceed 1 year from the date of substantial completion as defined in the Contract documents.

**Hellas Construction, Inc.** looks forward to the award of this project, and is eager to work with you.

***\*Pricing valid for 14 days from date of this proposal.***

A handwritten signature in black ink, appearing to read "Carlos Silva", with a stylized flourish extending to the right.

Carlos Silva  
Estimator  
Hellas Construction, Inc.  
[csilva@hellasconstruction.com](mailto:csilva@hellasconstruction.com)

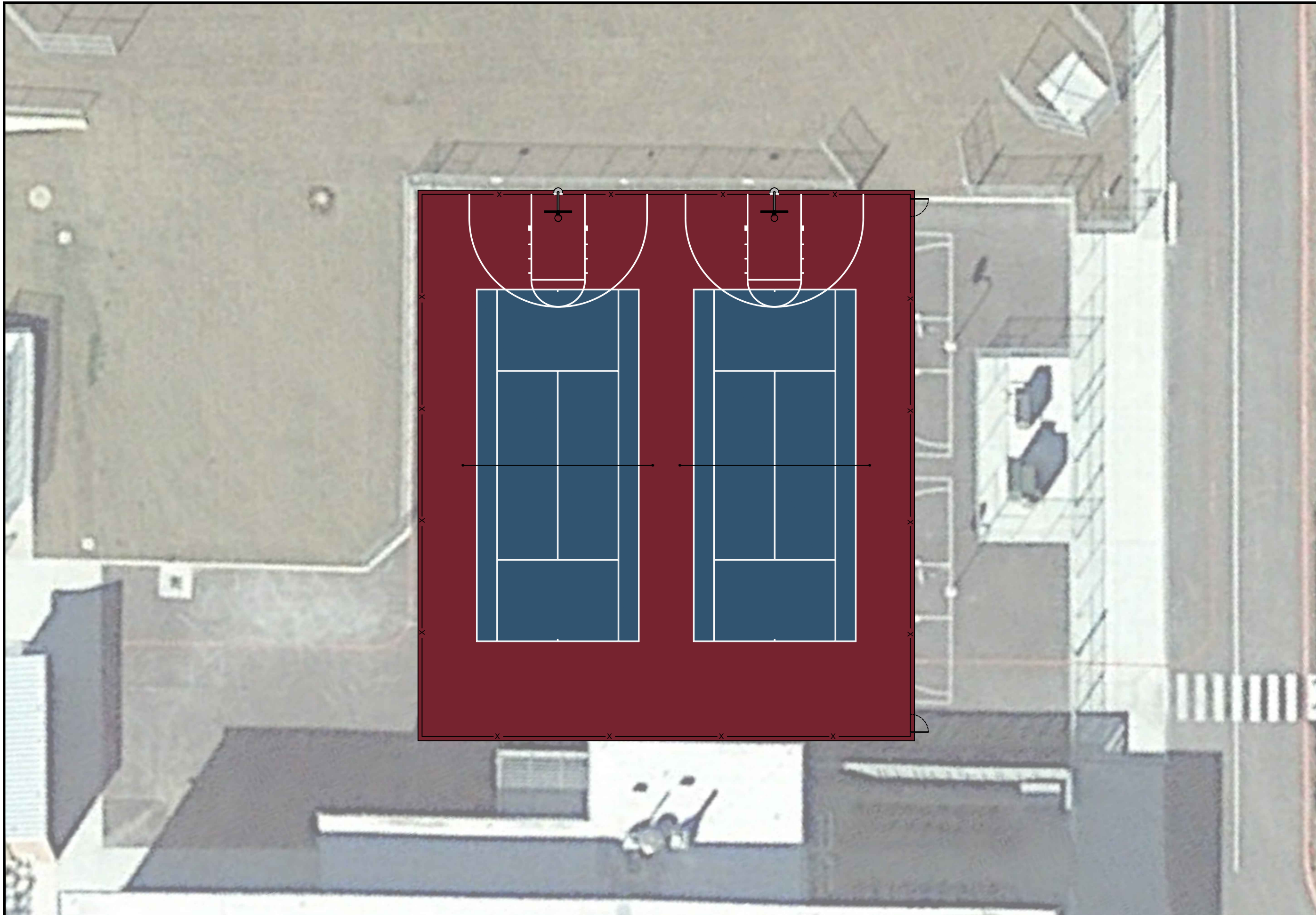

Hellas Construction, Inc. (P) (512) 250-2910  
12000 West Parmer Lane (F) (512) 250-1960  
Austin, TX 78613 hellasconstruction.com

**OWNER:**  
Medina Valley ISD  
Loma Alta Middle School  
266 Co Rd 381, San Antonio, TX 78253  
(830) 931-2243

**PROJECT:**  
TENNIS COURT CONSTRUCTION

**PROJECT LOCATION:**  
SAN ANTONIO, TEXAS

**TPS COURT SURFACES**



**COMMENTS:**  
Drawing scale accurate ONLY when printed on 11x17 paper. For visual purposes only, actual colors may vary.

**CREATED BY:** SDL

All drawings and written material appearing herein constitute original unpublished work, and may not be duplicated, used or disclosed without the written consent of Hellas Construction, Inc.

**DATE:**  
SEPTEMBER 14, 2022

**REVISION:**  
REV 4 OPT B

**SHEET TITLE:**  
COLOR RENDERING

**SHEET NUMBER:**  
1

© 2020

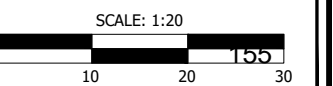



Hellas Construction, Inc. (P) (512) 250-2910  
12000 West Parmer Lane (F) (512) 250-1960  
Austin, TX 78613 hellasconstruction.com

**OWNER:**  
Medina Valley ISD  
Loma Alta Middle School  
266 Co Rd 381, San Antonio, TX 78253  
(830) 931-2243

**PROJECT:**  
TENNIS COURT CONSTRUCTION

**PROJECT LOCATION:**  
SAN ANTONIO, TEXAS

**TPS COURT SURFACES**



**COMMENTS:**  
Drawing scale accurate ONLY when printed on 11x17 paper. For visual purposes only, actual colors may vary.

**CREATED BY:** SDL

All drawings and written material appearing herein constitute original unpublished work, and may not be duplicated, used or disclosed without the written consent of Hellas Construction, Inc.

**DATE:**  
SEPTEMBER 14, 2022

**REVISION:**  
REV 4 OPT A

**SHEET TITLE:**  
COLOR RENDERING

**SHEET NUMBER:**  
1

© 2020

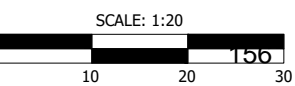

# Medina Valley Independent School District

## *Agenda Item Memorandum*

*To: MVISD Board of Trustees*

*Date: 9-19-2022*

*RE: Consider approving the budget amendment for September*

Finance is requesting the approval of the September Budget Amendment. This budget amendment is needed to pay for 2021-2022 approved purchase order items/services that were not received or completed in the 2021-2022 fiscal year. Funds will need to be added into the 2022-2023 budget in order to pay those remaining 2021-2022 purchase orders. The budget amendment will also pay for the construction of tennis courts at Loma Alta Middle School, purchase/installation of the HVAC Compressor at LaCoste Elementary and the purchase/installation of the new portable buildings, as these items were not included in the 2022-2023 budget.

**PROPOSED SEPTEMBER BUDGET AMENDMENT  
2022-2023 GENERAL FUND**

	2022-2023 ADOPTED BUDGET (AS OF 9/01/22)	2022-2023 AMENDED BUDGET	2022-2023 CURRENT AMENDMENTS (AS OF 8/29/22)	2022-2023 AMENDED BUDGET (AS OF 8/29/22)
<b>Estimated Revenues</b>				
5700 LOCAL AND INTERMEDIATE REVENUES	\$ 36,410,641	\$ -	\$ -	\$ 36,410,641
5800 STATE PROGRAM REVENUES	\$ 30,880,783	\$ -	\$ 2,025,713	\$ 32,906,496
5900 FEDERAL REVENUES	\$ 1,270,000	\$ -	\$ -	\$ 1,270,000
7900 OTHER SOURCES	\$ -	\$ -	\$ -	\$ -
<b>Total Estimated Revenue</b>	<b>\$ 68,561,424</b>	<b>\$ -</b>	<b>\$ 2,025,713</b>	<b>\$ 70,587,137</b>
<b>Appropriations</b>				
11 INSTRUCTION	\$ 39,809,875	\$ -	\$ 57,051	\$ 39,866,926
12 INSTRUCTIONAL RESOURCES/MEDIA SERVICES	\$ 671,445	\$ -	\$ -	\$ 671,445
13 CURRICULUM & INSTRUCTIONAL STAFF DEVELOPMENT	\$ 701,616	\$ -	\$ -	\$ 701,616
21 INSTRUCTIONAL LEADERSHIP	\$ 868,278	\$ -	\$ -	\$ 868,278
23 SCHOOL LEADERSHIP	\$ 3,447,370	\$ -	\$ -	\$ 3,447,370
31 GUIDANCE, COUNSELING & EVALUATION SERVICES	\$ 2,893,641	\$ -	\$ -	\$ 2,893,641
32 SOCIAL WORK SERVICES	\$ 490,242	\$ -	\$ -	\$ 490,242
33 HEALTH SERVICES	\$ 762,463	\$ -	\$ -	\$ 762,463
34 STUDENT (PUPIL) TRANSPORTATION	\$ 4,402,577	\$ -	\$ -	\$ 4,402,577
35 FOOD SERVICE	\$ 126,727	\$ -	\$ -	\$ 126,727
36 EXTRA-CURRICULAR ACTIVITIES	\$ 2,126,543	\$ -	\$ -	\$ 2,126,543
41 GENERAL ADMINISTRATION	\$ 2,309,578	\$ -	\$ -	\$ 2,309,578
51 PLANT MAINTENANCE & OPERATIONS	\$ 6,660,154	\$ -	\$ 128,292	\$ 6,788,446
52 SECURITY AND MONITORING	\$ 1,005,492	\$ -	\$ 374,395	\$ 1,379,887
53 DATA PROCESSING SERVICES	\$ 1,782,489	\$ -	\$ -	\$ 1,782,489
61 COMMUNITY SERVICES	\$ 9,987	\$ -	\$ -	\$ 9,987
71 DEBT SERVICE	\$ -	\$ -	\$ -	\$ -
81 FACILITIES AND CONSTRUCTION	\$ 2,947	\$ -	\$ 1,465,975	\$ 1,468,922
95 JUVENILE JUSTICE ALTERNATIVE	\$ 5,000	\$ -	\$ -	\$ 5,000
99 OTHER INTERGOVERNMENTAL CHARGES	\$ 485,000	\$ -	\$ -	\$ 485,000
8911 OTHER USES	\$ -	\$ -	\$ -	\$ -
<b>Total Appropriations</b>	<b>\$ 68,561,424</b>	<b>\$ -</b>	<b>\$ 2,025,713</b>	<b>\$ 70,587,137</b>
<b>Net (Revenues Less Appropriations)</b>	<b>\$ -</b>	<b>\$ -</b>	<b>\$ -</b>	<b>\$ -</b>