



REGULAR BOARD MEETING OF THE BOARD OF TRUSTEES

**TUESDAY, MAY 21, 2024
6:00 PM**

**Alamo Colleges District
Dr. Bruce H. Leslie Boardroom
2222 N. Alamo St.
San Antonio, TX 78215**

NOTICE IS HEREBY GIVEN THAT THE REGULAR BOARD MEETING OF THE BOARD OF TRUSTEES OF THE ALAMO COMMUNITY COLLEGE DISTRICT WILL BE HELD AT THE PHYSICAL LOCATION REFERENCED ABOVE ON TUESDAY, MAY 21, 2024. ONE OR MORE TRUSTEES MAY ATTEND REMOTELY BY VIDEOCONFERENCE PROVIDED THAT A QUORUM OF TRUSTEES ATTEND BY PHYSICAL PRESENCE AS AUTHORIZED BY TEXAS GOVERNMENT CODE SECTION 551.127. THE REGULAR BOARD MEETING OF THE BOARD WILL CONVENE IN OPEN SESSION AT 6:00 PM.

This Regular Board Meeting of the Board of Trustees, being held for the reasons listed below, is authorized in accordance with the Texas Government Code, §§ 551.001 - 551.146. Verification of Notice of Meeting and Agenda are on file in the Office of the Chancellor. Executive Session, if required, is authorized by Chapter 551 and will be conducted prior to the conclusion of the meeting. If it is decided during the course of the meeting that discussion of any item listed on the agenda should be held in Executive Session, the Board will convene in Executive Session in accordance with Tex. Govt. Code §§ 551.071 - 551.094. In order to vote on items discussed in Executive Session, the Board of Trustees must take action in the open portion of the meeting on items discussed in the Executive Session. The Board will consider, discuss, and take appropriate action regarding the following items:

AGENDA

- 1. **CALL TO ORDER**
- 2. **CERTIFICATION AND POSTING**
- 3. **ROLL CALL**
- 4. **PLEDGE OF ALLEGIANCE**
- 5. **INVOCATION** - *Miles Rodriguez*, Student Peace Center, Northwest Vista College
- 6. **MEMORIALS**
- 7. **RECOGNITIONS**
 - 7.A. Roberto Zarate - Outgoing Chair and Service Recognition
Presenter: Clint Kingsbery and Dr. Mike Flores
 - 7.B. AlamoPROMISE Student of the Month - Jennifer Toledo, Northwest Vista College
Presenter: Dr. Amy Bosley
 - 7.C. Northwest Vista College - Semifinalist for the Prestigious 2025 Aspen Prize for Community College Excellence

Presenter: Dr. Amy Bosley

7.D. Alamo Colleges District Employee of the Month - *Allen Anguiano*, Northeast Lakeview College

Presenter: Dr. Veronica Garcia

7.E. International Education: Paul Simon Award and Student Competition Recognition

Presenter: Alejandra Bueno

7.F. 2024 Marketing & Communications Awards and Recognitions - NCMPR & PRSA

Presenter: Kristi Wyatt

8. **NEW BUSINESS**

8.A. Discussion and Possible Action on Granting of Emeritus Status - *Dr. Hayford Awuku*, St. Philip's College

Presenter: Dr. Adena Loston

8.B. Discussion and Possible Action on Granting of Emeritus Status - *Dr. Roger Biduaka*, St. Philip's College

Presenter: Dr. Adena Loston

8.C. Discussion and Possible Action on Granting of Emeritus Status - *Dr. Walker Hunt*, San Antonio College

Presenter: Dr. Francisco Solis

9. **CITIZENS TO BE HEARD**

9.A. Registration: 5:00 PM - 5:55 PM

10. **EXECUTIVE SESSION**

10.A. The Board may go into Executive Session to deliberate on any item referenced in this agenda for open session or executive session based on the following potential exceptions under the Act.

10.B. Pursuant to §551.071, Texas Government Code, the Board may consult with its attorney(s) to seek their advice on any matter(s) in which the duty of the attorney(s) to the governmental body under the Texas Disciplinary Rules of Professional Conduct of the State Bar of Texas clearly conflicts with this chapter.

10.C. Pursuant to §551.071, Texas Government Code, the Board may consult with its attorneys about pending and threatened litigations.

10.D. Pursuant to §551.074, Texas Government Code, the Board may consult with its attorneys about pending EEOC charges.

10.E. Pursuant to §551.072, Texas Government Code, the Board may deliberate the purchase, exchange, lease or value of real property.

10.F. Pursuant to §551.073, Texas Government Code, the Board may deliberate regarding a negotiated contract for prospective gift or donation.

10.G. Pursuant to §551.074, Texas Government Code, the Board may deliberate the appointment, employment, evaluation, reassignment, duties, performance of duties, discipline, or dismissal of a public officer or employee(s), including, without limitation, the Chancellor.

10.H. Any action on these matters will be taken in Open Session.

11. **RECONVENE OPEN MEETING**

11.A. Discussion and Possible Action on Items Discussed in Executive Session.

12. **CHAIR'S REPORT**

12.A. Community Outreach; SA Chamber Honoring Dr. Adena Loston, and San Antonio Missions Game

13. **CHANCELLOR'S REPORT**

13.A. Financial Aid - FAFSA Update

14. **AUDIT, BUDGET AND FINANCE COMMITTEE, Dr. Yvonne Katz, Chair**

14.A. FY23 Single Audit Results

Presenter: Patrick Vrba

14.B. Discussion and Possible Action on the Annual Debt Management Plan for FY25

Presenter: Sean Mullen

14.C. Discussion and Possible Action for the Purchase of a Feasibility Study and Implementation of a Comprehensive Fundraising Campaign

Presenter: Barton Simpson

14.D. Discussion and Possible Action on Purchasing Equipment for St. Philip's College Cybersecurity Curriculum

Presenter: Dr. Ray Chacon

15. **WORKFORCE DEVELOPMENT COMMITTEE**, *Dr. Gene Sprague, Chair*

15.A. Discussion and Possible Action on the Northeast Lakeview College AAS in Nursing

Presenter: Dr. Crystal Saulsberry

16. **BUILDING, GROUNDS & SITES SELECTION COMMITTEE**, *Gloria Ray, Chair*

16.A. Discussion and Possible Action on the Purchase of Facilities Custodial and Ground Services

Presenter: Greg McClure

16.B. Discussion and Possible Action to Approve Four Guaranteed Maximum Prices and Associated Construction Manager at Risk Contracts for Alamo Colleges District - Maintenance Tax Note 2022 Funded Projects for San Antonio College and St Philip's College

Presenter: Greg McClure

16.C. Discussion and Possible Action on the Purchase of Construction Services for Palo Alto College Building 6, Student Commons Underfloor and Site Drainage Improvements

Presenter: Greg McClure

16.D. Discussion and Possible Action on Guaranteed Maximum Price for Alamo Colleges District - Northwest Education and Training Center Capital Improvement Project (CIP), Construction Manager-at-Risk Contract with Thomas S. Byrne D/B/A Byrne Construction Services. (CSP 18C-005)

Presenter: Lacy Hampton

16.E. Discussion and Possible Action on the Adoption of a Revised 2017 Capital Improvement Program Project Budget for Northwest Education and Training Center (NWETC) with Impacts of Real Estate Savings

Presenter: Lacy Hampton

17. **LEGISLATIVE COMMITTEE**, *Joe Alderete, Jr., Chair*

17.A. Legislative Report

Presenter: Priscilla Camacho

18. **POLICY AND LONG-RANGE PLANNING COMMITTEE**, *Dr. Lorraine Pulido, Chair*

18.A. Discussion and Possible Action on State Law Prohibitions H.3.1

Presenter: Dr. Daphene Carson & Ross Laughead

18.B. Discussion and Possible Action on Debt Management C.3.1

Presenter: Dr. Daphene Carson & Lisa Mazure

19. **PERSONNEL**

19.A. Discussion and Possible Action on Appointment of Full-Time Faculty

Presenter: Linda Boyer-Owens

19.B. Discussion and Possible Action on Appointment of Administrators

Presenter: Linda Boyer-Owens

19.C. Discussion and Possible Action on Renewal of Certain Administrative Contracts Including but not Limited to Presidents and Vice Chancellors.

Presenter: Linda Boyer-Owens

20. **CONSENT AGENDA**

20.A. Discussion and Possible Action on Consent Agenda Items

20.A.1) Approval of Board Meeting Minutes

20.A.1)a. Discussion and Possible Action on Approval of Minutes of the Meeting of the Board of Trustees - Meeting as a Committee of the Whole on April 9, 2024

- 20.A.1)b. Discussion and Possible Action on Minutes of the Regular Board Meeting on April 16, 2024
- 20.A.1)c. Discussion and Possible Action on Minutes of the Special Board Meeting on April 23, 2024
- 20.A.2) Internal Audit Department Monthly Activity Report
- 20.A.3) Discussion and Possible Action on Acceptance of Private Gifts to the Alamo Colleges Foundation and Alamo Colleges District
- 20.A.4) Department of Public Safety Monthly Clery Act Activity Report
- 20.A.5) Discussion and Possible Action on Approval of Report of Policies Reviewed with No Substantive Changes
- 20.A.6) Fiscal Services Reports
 - 20.A.6)a. Discussion and Possible Action on Monthly Contracts Report
 - 20.A.6)b. Discussion and Possible Action on Monthly Grants and Contracts Report
 - 20.A.6)c. Discussion and Possible Action on Approval of Construction Reports
 - 20.A.6)d. Capital Improvement Program (CIP) Executive Summary
 - 20.A.6)e. Discussion and Possible Action on Approval of Financial Reports
 - 20.A.6)f. Discussion and Possible Action on Approval of Monthly Report on Cooperative Purchases in Excess of \$200,000
 - 20.A.6)g. Discussion and Possible Action on Acceptance of the FY 2023- 2024 Budget: Amendment No. 3
 - 20.A.6)h. Discussion and Possible Action for the Purchase of Banking Services
 - 20.A.6)i. Discussion and Possible Action on Amending the Guaranteed Maximum Price (GMP) for Alamo Colleges District San Antonio College Empowerment Center (CSP 18C-005)

21. SETTING OF NEXT MEETING DATE

21.A. Regular Meeting of the Alamo Colleges Board of Trustees is scheduled for July 23, 2024

22. ADJOURNMENT

POSTED AT THE
 ALAMO COMMUNITY COLLEGE DISTRICT
 2222 N. Alamo St.; San Antonio, TX 78215 at
 POSTED AT 5:15 PM ON THIS 17TH DAY OF MAY 2024

This meeting site is wheelchair accessible. The accessible entrance is located at the side entrance of Dr. Bruce H. Leslie Boardroom. Accessible parking spaces are located in front of the Alamo Colleges Center for Excellence and Student Success, located in the parking lot that faces N. Alamo Street. Auxiliary aids and services are available upon request (interpreters for the hearing impaired must be requested twenty-four hours prior to the meeting) by contacting the Board of Trustees Office at dst-board@alamo.edu.

“The following notices apply to this meeting.

“Pursuant to Section 30.06, Penal Code, a person may not enter this property with a concealed handgun, whether or not that person is licensed under Subchapter H, Chapter 411, Government Code (handgun licensing law).”

Pursuant to Section 30.07, Penal Code, a person may not enter this property with a handgun that is carried openly, whether or not that person is licensed under Subchapter H, Chapter 411, Government Code (handgun licensing law).”

Dr. Mike Flores
Chancellor

Employee and Student Memorials

Regular Meeting of the Board of Trustees
May 21, 2024

Linda Boyer-Owens, SPHR, SHRM-SCP

Associate Vice Chancellor for Talent, Organization, and Strategic Innovation

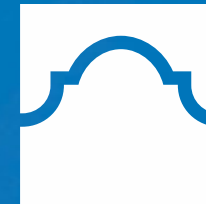

ALAMO
COLLEGES
DISTRICT



Employee Memorials

Gilberto Becerra, Jr.

Associate Vice Chancellor for Student Advocacy, Retention & Completion

ACCESS

Employed: 09/14/2015 to 05/02/2024

Departed: May 2, 2024

Betty Jean Maroscher

Associate Professor,

St. Philip's College

Employed: 12/01/1975 to 08/31/1999

Departed: May 11, 2024



Employee Memorials

Elva De Los Santos

Sr. Specialist Student Success
St. Philip's College

Employed: 09/01/1983 to 01/31/2010
& 07/18/2012 to 02/28/2024
Departed: February 28, 2024

Helga Hintner

Professor,
San Antonio College
Employed: 09/01/1969 to 08/31/1998
Departed: January 25, 2024



Student Memorials

There are no student memorials this month

Thank you.

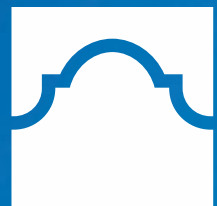

ALAMO
COLLEGES
DISTRICT



AlamoPROMISE Student of the Month: Jennifer Toledo



- 2022 graduate of John Paul Stevens
- Pursuing Associate of Arts in Teaching
- Member of Phi Theta Kappa Honor Society
- NVC President's Student Advisory Council
- Student employee in NVC's Student Success
- Planning to transfer to UTSA
- Aiming for a Bachelor of Arts in Bilingual Education as well as a Master of Arts and a Doctor of Philosophy in Culture, Literacy & Language

“AlamoPROMISE changed my life... it makes a college degree a reality.”





**AlamoPROMISE STUDENT OF THE MONTH
May 2024**

**Jennifer Toledo
Northwest Vista College**

Jennifer Toledo is the May 2024 AlamoPROMISE Student of the Month.

Jennifer is a 2022 graduate of John Paul Stevens High School. She is currently pursuing her Associate of Arts in Teaching at NVC. Upon completion, Jennifer plans to transfer to UTSA to obtain a Bachelor's in Bilingual Education. She envisions herself pursuing further studies by obtaining a Master's and Ph.D. in Culture, Literacy, and Language. Jennifer is hoping to one day serve at Alamo Colleges as a staff/faculty member and encourage students to persevere.

Jennifer is not only a dedicated student but also an active participant in various organizations. Jennifer is a member of the Phi Theta Kappa (PTK) honor society, where she continues to excel academically while contributing positively to the college community. She also serves as a member of the President's Student Advisory Council, providing input from the student perspective.

The AlamoPROMISE program has had a profound impact on Jennifer's pathway to success. As a first-generation college student, Jennifer's family takes pride in her accomplishments. The support provided by AlamoPROMISE has been instrumental in making her dreams of higher education a reality. The program's commitment to removing financial barriers has empowered Jennifer to pursue her education without the burden of worrying about tuition costs. Jennifer would like to thank the AlamoPROMISE program and donors for making a college degree a reality.



Dear Alamo Colleges Board of Trustees,

I am writing to express my gratitude for being selected as the AlamoPROMISE student of the month award. Receiving this prestigious award is an immense honor and I am incredibly grateful for the recognition of my academic achievements and potential.

AlamoPROMISE has had a powerful impact on my life and my education. As the first generation in my family to go to college, my family is proud of me. AlamoPROMISE changed my life because I never thought I would be able to attend college due to the cost of tuition, but thanks to AlamoPROMISE I can attend college without having to stress about the cost. AlamoPROMISE made a college degree a reality.

I am honored by the generosity of the donors who have supported the AlamoPROMISE program. Their support not only eases the financial burden of pursuing higher education, but also serves as a testament to their belief in my abilities and potential for success. This award reaffirms my commitment to academic excellence and inspires me to continue striving for achieving greatness in all aspects of my educational journey.

Also, I am grateful for the financial assistance that AlamoPROMISE has provided me. This has alleviated a significant burden and has made it possible for me to pursue my educational goals without undue financial stress. This support has not only lightened my load but has also reaffirmed my belief in the power of community and collective investment in education.

Once again, thank you from the bottom of my heart for this incredible honor. Your support means the world to me

With sincerest appreciation,
Jennifer Toledo
Northwest Vista College

Northwest Vista College Semifinalist for the Aspen Prize

ASPEN PRIZE
FOR COMMUNITY COLLEGE EXCELLENCE
aspen institute

SEMIFINALIST

2025



ALAMO
COLLEGES
DISTRICT





ALAMO COLLEGES EMPLOYEE OF THE MONTH

May 2024

Allen Anguiano

Director of Student Success
Northeast Lakeview College

Allen has been involved in higher education for 5 years at Northeast Lakeview College. At NLC, he has served as Intramural Specialist, Coordinator of Student Success, and recently became Director of Student Success in the Office of Student Life. He oversees Student Engagement, Clubs and Organizations, Intramural and Extramural Sports, and Campus Activities.

His favorite NLC value is Students First, one of our most important Alamo Colleges District values. Allen is most passionate about making a positive difference in students' lives and helping them be successful in and out of the classroom. He's an avid golfer, and enjoys camping, hiking, fishing, and going to the lake. Allen has a bachelor's degree from The University of Texas at San Antonio and a master's degree from Howard Payne University.

Please help me in congratulating Allen for being selected as the May 2024 Alamo Colleges Employee of the Month by the Alamo Colleges Executive Staff Senate.



ALAMO
COLLEGES
DISTRICT



OFFICE OF INTERNATIONAL PROGRAMS

2024 NAFSA Paul Simon Award to Comprehensive Internationalization

&

Alamo Global Challenge

Alejandra Bueno, J.D.

Executive Director,
Office of International Programs

May 21, 2024



ALAMO
COLLEGES
DISTRICT



About NAFSA

Largest Non-Profit Organization in
International Education
with over 10,000 members

Texas History of Awardees

The University of Texas at Austin in 2021
Texas Tech University in 2018
Lone Star College System in 2013



Other Awardees in 2024 Comprehensive Award

Alamo Colleges District

Auburn University

Prairie View A&M University

University of California, Santa Cruz

Comprehensive or Spotlight?

Alamo Colleges has received the
Comprehensive Award for:

**Engagement, Programmatic Efforts,
Curriculum/Faculty Development, and
Partnerships/Outreach**

Each area requires a demonstration of
intentionality, planning, progress
measurement, and achieved outcomes.

Who was Paul Simon?

Named after the late Senator Paul Simon of Illinois, the awards celebrate outstanding commitment and accomplishment in campus internationalization. The Senator Paul Simon Award for Comprehensive Internationalization recognizes excellence in integrating international education throughout all facets of university and college campuses.

ALAMO GLOBAL CHALLENGE

- Experiential Learning Opportunity
 - Encourages exploration, cultural enrichment, personal growth, and global competence
- Learning journey is linked to Alamo Global Competencies
 - Students will engage in reflective journaling and assessments during their trip abroad
 - All global competencies will be addressed, and corresponding badges awarded

Summer 2023

Victor Cadena - **NVC**

Jeffrey Davila - **NLC**

Mariela Eslora - **PAC**

Yarely Rocha - **SAC**

Viviane Altuzar Guadarrama - **SPC**

Summer 2024

Sophia Prieto - **SAC**

Mariela Eslora - **SPC**

Mark Sanchez - **NVC**

Mya Leon - **NLC**

Alesandra Jimenez - **PAC**

GLOBAL CHALLENGE WINNERS 2023



GLOBAL CHALLENGE WINNERS 2024



ALAMO
COLLEGES
DISTRICT



Thank you!



Alamo Colleges District

2024 Marketing & Communications Awards and Recognitions

Kristi Wyatt

Associate Vice Chancellor of Communications & Engagement

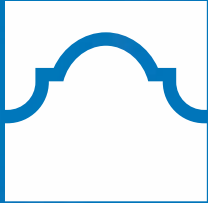

ALAMO
COLLEGES
DISTRICT





National Council for Marketing & Public Relations



ALAMO COLLEGES DISTRICT
St. Philip's College

- o Logo Wear



- o Mosaico Invitation



ALAMO COLLEGES DISTRICT



- o A Seat at the Table Podcast



ALAMO COLLEGES DISTRICT





PRSA Del Oro Individual Awards

- Public Relations Champion Award – Dr. Lorena “Lorraine” Pulido
- Social Responsibility Champion Award – AlamoPROMISE

PRSA Del Oro Team Awards

- A Seat at the Table Podcast – District Marcomm
- Alamo Colleges District Mobile App – District Marcomm
- AlamoPROMISE Integrated Communications – District Marcomm

Alamo Colleges District Emeritus – Dr. Hayford Awuku

- 28 Years of Service
- Promoted student success, retention, and recruitment
- Provided outstanding advising in promoting student transition to higher education endeavors - St. Philip's Natural Sciences Department
- Kept abreast of modern technological trends in higher education teaching by attending several workshops and seminars and participating in grants
- Held weekly “boot camp” physics tutoring sessions open to all physics students to reinforce a better understanding of the physics material covered during class sessions and in preparing students for the MCAT exams for entrance into medical schools and PCAT exams for entrance into pharmacy colleges
- Served on several college and district committees to include SPC Instructional Technology Committee, International Programs Committee, Student Fee-Advisory Committee, Jessica's Project Committee and various hiring committees
- Engaged in community outreach and service, participating in Texas High School Science and Engineering fairs to promote physics
- Mentored adjunct faculty members, making sure that high standards of physics instruction were maintained

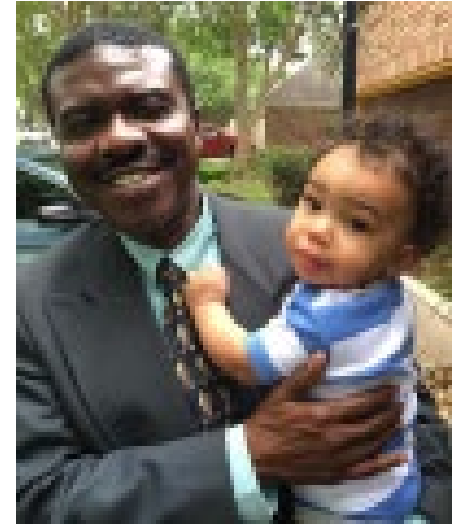

Dr. Awuku with his grandson



Thank you.



ALAMO
COLLEGES
DISTRICT



Discussion and Possible Action on Granting of Emeritus Status of the Natural Sciences Department at St. Philip’s College in the Alamo Colleges District

Presented for recommended approval to the ALAMO COLLEGES BOARD OF TRUSTEES on May 21 2024.

MINUTE ORDER

"The Board of Trustees hereby approves, with the recognition and appreciation for 28 years of dedicated service to Alamo Colleges District – St. Philip’s College and with the recommendation of the faculty and administration of Alamo Colleges District- St. Philip’s College and the Chancellor of the College District, Dr. Hayford Awuku, Professor Emeritus of the Natural Sciences Department at Alamo Colleges District – St. Philip’s College."

PURPOSE

To approve Emeritus status to a retired professor at Alamo Colleges District – St. Philip’s College.

BACKGROUND

The Board may approve emeritus status for retiring full-time faculty members or administrators as recommended by the Chancellor according to administrative guidelines. With respect to the designation of Professor Emeritus, the qualifications and appointment shall be at the sole discretion of the Board (Policy D.10.4).

IMPLICATIONS

- Financial:** None
- Strategic Objective:** All
- Human Resources:** Recognition of Faculty and Administrators

ATTACHMENTS: Dr. Hayford Awuku Emeritus – Resolution
Dr. Hayford Awuku Emeritus PowerPoint

Adena Williams Loston 3/7/2024
Dr. Adena Williams Loston Date
President, St. Philip’s College

Linda Boyer-Owens Date
Associate Vice Chancellor for Talent,
Organization and Strategic Innovation

Dr. Mike Flores Date
Chancellor

RESOLUTION

WHEREAS, Dr. Hayford Awuku joined Alamo Colleges - St. Philip's College Natural Sciences department as a tenure track faculty in August 1993 and was granted tenure in 1996 and was promoted to Professor in 2002, and

WHEREAS, he earned a Bachelor of Science degree in Electrical and Electronic Engineering from Kwame Nkrumah University of Science and Technology, Kumasi, Ghana and a PhD degree in Physics from Baylor university, Waco, Texas, and

WHEREAS, he has promoted student success, retention, and recruitment through his untiring commitment to the quality of teaching in the Alamo Colleges. Furthermore, he has provided outstanding advising in promoting student transition to higher education endeavors - St. Philip's Natural Sciences Department, and

WHEREAS, he has kept himself abreast of modern technological trends in higher education teaching by attending several workshops and seminars including Vernier Lab Quest Workshops sponsored by our collaborative Title V grant with UIW, Master Teacher Certification offered at St. Philips College and Collaborative and Cooperative learning style seminars offered at UIW, and

WHEREAS, he held weekly "boot camp" physics tutoring sessions open to all physics students to reinforce a better understanding of the physics material covered during class sessions and in preparing students for the MCAT exams for entrance into medical schools and PCAT exams for entrance into Pharmacy colleges, and

WHEREAS, he served on several college and district committees to include SPC Instructional Technology Committee, International Programs Committee, Student Fee-Advisory Committee, Jessica's Project Committee and various hiring committees, and

WHEREAS, he has engaged in community outreach and service, participating in Texas High School Science and Engineering fairs to promote physics, and

WHEREAS, he mentored adjunct faculty members, making sure that high standards of physics instruction were maintained, and

WHEREAS, he regularly attended the annual TCCTA (Texas Community College Teachers Association) conference and participated in new technology trends, as well as faculty enhancement programs for two-year colleges, and

WHEREAS, he has always maintained high standards and academic rigor in his teaching, attending many professional development workshops such as AAPT (American Association of Physics Teachers), and

WHEREAS, Dr. Hayford Awuku requested retirement effective July 31, 2021, and

WHEREAS, the Board of Trustees of the Alamo Colleges accepted his request for retirement with recognition and appreciation for twenty-eight years of dedicated service to the Alamo Colleges – St. Philip’s College, and

NOW, THEREFORE BE IT RESOLVED that the Board of Trustees hereby approves, with the recognition and appreciation for 28 years of dedicated service to Alamo Colleges District – St. Philip’s College and with the recommendation of the faculty and administration of Alamo Colleges District- St. Philip’s College and the Chancellor of the College District, Dr. Hayford Awuku, Professor Emeritus of the Natural Sciences Department at Alamo Colleges District – St. Philip’s College.”

Alamo Colleges District Emeritus – Dr. Roger Biduaka

- 28 Years of Service
- Promoted students' success, retention, and recruitment through his commitment to the quality of teaching at Alamo Colleges
- Provided outstanding leadership in advising and promoting students' transition to higher educational endeavors
- Kept himself abreast of modern technology used in higher education, attending workshops
- Held weekly biology tutoring sessions at the Byrd Sanctuary (the Natural Sciences Tutoring Lab) to develop student learning and prepare students for medical, pharmacy, dental and nursing schools
- Served on numerous college and district committees
- Engaged in community outreach and service, participating in Texas High School Science fairs to promote biology
- Mentored adjunct faculty members, making sure that high standards of biology instruction were maintained
- Regularly attended the annual TCCTA (Texas Community College Teachers Association)
- Established the "Peanut Club" to recognize the top students in anatomy & physiology



Dr. Biduaka (left) presenting "peanut" award to top performing student



Thank you.



ALAMO
COLLEGES
DISTRICT



Discussion and Possible Action on Granting of Emeritus Status of the Biology Department at St. Philip’s College in the Alamo Colleges District

Presented for recommended approval to the ALAMO COLLEGES BOARD OF TRUSTEES on May 21, 2024.

MINUTE ORDER

"The Board of Trustees hereby approves, with the recognition and appreciation for 28 years of dedicated service to Alamo Colleges District – St. Philip’s College and with the recommendation of the faculty and administration of Alamo Colleges District- St. Philip’s College and the Chancellor of the College District, Dr. Roger Biduaka, Professor Emeritus of Biology at Alamo Colleges District – St. Philip’s College."

PURPOSE

To approve Emeritus status to a retired professor at Alamo Colleges District – St. Philip’s College.

BACKGROUND

The Board may approve emeritus status for retiring full-time faculty members or administrators as recommended by the Chancellor according to administrative guidelines. With respect to the designation of Professor Emeritus, the qualifications and appointment shall be at the sole discretion of the Board (Policy D.10.4).

IMPLICATIONS

- Financial:** None
- Strategic Objective:** All
- Human Resources:** Recognition of Faculty and Administrators

ATTACHMENTS: Dr. Roger Biduaka Emeritus – Resolution
Dr. Roger Biduaka Emeritus PowerPoint

Adena Williams Loston 3/7/2024
Dr. Adena Williams Loston Date
President, St. Philip’s College

Linda Boyer-Owens Date
Associate Vice Chancellor for Talent,
Organization and Strategic Innovation

Dr. Mike Flores Date
Chancellor

RESOLUTION

WHEREAS, Dr. Roger M. Biduaka joined Alamo Colleges - St. Philip's College Natural Sciences department as a tenure track faculty in August 1993 and was granted tenure in 1998 and was promoted to Associate Professor in 2002, and

WHEREAS, he earned a Doctorate in Veterinary Medicine from the University of Lubumbashi, Zaire and a Master's degree in Sciences from the University of Illinois at Urbana-Champaign, Illinois, and

WHEREAS, he promoted students' success, retention, and recruitment through his untiring commitment to the quality of teaching at Alamo Colleges. Furthermore, he provided outstanding leadership in advising and promoting students' transition to higher educational endeavors, and

WHEREAS, he has kept himself abreast of modern technology used in higher education teaching by attending several workshops and seminars including Vernier Lab Quest Workshops sponsored by our collaborative Title V grant with UIW, Master Teacher Certification offered at St. Philip's College and Collaborative and Cooperative learning style seminars offered at UIW, and

WHEREAS, he held weekly biology tutoring sessions at the Byrd Sanctuary (the Natural Sciences Tutoring Lab). His tutoring sessions were sought out by biology students to strengthen/ clarify their understanding of the material covered in class. Other students used it as a way to prepare for the entrance exams used in medical, pharmacy, dental and nursing schools, and

WHEREAS, he served on numerous college and district committees to include SPC Instructional Technology Committee, International Programs Committee, Student Fee-Advisory Committee, Instructional Unit Review Committee, Jessica's Project committee and various hiring committees, and

WHEREAS, he has engaged in community outreach and service, participating in Texas High School Science fairs to promote biology, and

WHEREAS, he mentored adjunct faculty members, making sure that high standards of biology instruction were maintained, and

WHEREAS, he regularly attended the annual TCCTA (Texas Community College Teachers Association) conference and participated in new technology trends, as well as faculty enhancement programs for two-year colleges, and

WHEREAS, he has attended many professional development workshops such as SSR (Society for the Study of Reproduction). He insisted on high standards and academic

rigor in his teaching and promoted academic excellence in his students. He established the “Peanut Club” to recognize the top student in anatomy & physiology and

WHEREAS, Dr. Roger M. Biduaka requested retirement effective December 31, 2021, and

WHEREAS, the Board of Trustees of the Alamo Colleges accepted his request for retirement with recognition and appreciation for twenty-eight years of dedicated service to the Alamo Colleges – St. Philip’s College, and

NOW, THEREFORE BE IT RESOLVED that the Board of Trustees hereby approves, with the recognition and appreciation for 28 years of dedicated service to Alamo Colleges District – St. Philip’s College and with the recommendation of the faculty and administration of Alamo Colleges District- St. Philip’s College and the Chancellor of the College District, Dr. Roger Biduaka, Professor Emeritus of Biology at Alamo Colleges District – St. Philip’s College.

Professor Emeritus: Walker Eugene Hunt, Ph.D.



- Longest serving San Antonio College employee at 57 years.
- Engaged over 20,000 students during his tenure.
- Served on the hiring committee for most of the current Math Department faculty.
- Served as faculty advisor for the Black Student Union.
- Served on the Faculty Senate.
- Respected and admired member of the Mathematics Department for upholding the highest standards and maintaining the respect of his students throughout his tenure.



Discussion and Possible Action on Granting of Emeritus Status of the Mathematics Department at San Antonio College in the Alamo Colleges District

Presented for recommended approval to the ALAMO COLLEGES BOARD OF TRUSTEES on May 21, 2024.

MINUTE ORDER

"WHEREAS, he was honored by The Senate of The State of Texas with Senate Resolution No. 76 in his memory. The Board of Trustees hereby approves, with the recognition and appreciation for 57 years of dedicated service to Alamo Colleges District – San Antonio College and with the recommendation of the faculty and administration of Alamo Colleges District- San Antonio College and the Chancellor of the College District, Dr. Walker Hunt, Professor Emeritus of the Mathematics Department at Alamo Colleges District – San Antonio College."

PURPOSE

To approve Emeritus status to a retired professor at Alamo Colleges District- San Antonio College.

BACKGROUND

The Board may approve emeritus status for retiring full-time faculty members or administrators as recommended by the Chancellor according to administrative guidelines. With respect to the designation of Professor Emeritus, the qualifications and appointment shall be at the sole discretion of the Board (Policy D.10.4).

IMPLICATIONS

Financial: None
Strategic Objective: All
Human Resources: Recognition of Faculty and Administrators

ATTACHMENTS: Resolution

Linda Boyer-Owens Digitally signed by Linda Boyer-Owens
Date: 2024.05.08 15:52:26 -05'00'

Linda Boyer-Owens Date
Associate Vice Chancellor for Talent,
Organization and Strategic Innovation

Dr. Francisco Solis Date
Interim President
San Antonio College

Dr. Mike Flores Date
Chancellor



RESOLUTION

WHEREAS, Walker Eugene Hunt began teaching mathematics at San Antonio College in 1966;

WHEREAS, in 1956 he was part of the first cohort of African American students at the University of Texas, known as the Precursors, who trailblazed a path for generations of African American scholars to come;

WHEREAS, he earned a BA and MA in Mathematics from the University of Texas;

WHEREAS, he earned a Ph.D. in Mathematics from the University of Texas;

WHEREAS, he was promoted to Professor in 1979;

WHEREAS, he displayed outstanding teaching abilities and qualities;

WHEREAS, he frequently taught the department's highest-level courses;

WHEREAS, he upheld the highest of standards and maintained the respect of his students throughout his tenure;

WHEREAS, he maintained membership in several professional organizations;

WHEREAS, he attended numerous mathematical conventions to help improve his teaching skills;

WHEREAS, he served on the hiring committee for most of the current math faculty;

WHEREAS, he served on various other departmental, college, and district committees;

WHEREAS, he served as advisor to many of his students;

WHEREAS, he served as faculty advisor for the Black Student Union;

WHEREAS, he served on the Faculty Senate;

WHEREAS, he often volunteered, when not on salary, to perform duties to help the College and the department;

WHEREAS, he engaged over 20,000 students during his tenure;

WHEREAS, he was a respected and admired member of the Mathematics Department and

WHEREAS, Walker Eugene Hunt entered eternal rest September 1, 2023.

WHEREAS, he was honored by The Senate of The State of Texas with Senate Resolution No. 76 in his memory.

THEREFORE BE IT RESOLVED that Walker Eugene Hunt be awarded the title of Professor Emeritus.

TO BE READ BY BOARD CHAIR BEFORE CTBH ITEM

Citizens To Be Heard Standard Statement

All individuals wishing to address the Board should have signed up to do so.

Comments relating to general matters shall be presented during the Citizens To Be Heard portion of the meeting. Comments relating to a specific item or items on the Board's agenda may be presented (a) during the Citizens To Be Heard portion of the meeting or (b) during consideration of the specific agenda item or items.

- No presentations shall exceed three (3) minutes.
- If ten (10) or more person sign up to comment on a specific item, each speaker may be limited to two (2) minutes by majority vote of the Board.
- Individuals needing a translator will have a six-minute time period.
- No individual is allowed to transfer his or her time to another individual.
- When the timer beeps, please finish your sentence so that we can allow others to have their voice heard.
- Please introduce yourself by name and state whether you represent yourself, an organization or an employer.

Please know that your right to speak may be withdrawn by the Board Chairman if you are discourteous, disrespectful, or are otherwise likely to impede, interfere with or otherwise obstruct this meeting.

State law limits Trustee response to public comments.

Financial Aid Update

- **The Department of Education redesign of the FAFSA process (“FAFSA Simplification”) has created significant delays for all colleges & universities.**
 - Delaying availability of the FAFSA from Oct 1, 2023, to Jan 1, 2024.
 - Affecting student’s decisions about school attendance without financial aid information.
 - Affecting school’s ability to award students.
- **Current Impact:** 6,152 less FAFSA data records loaded into Banner.

	17-May-24	17-May-23
Academic Year	2024-2025	2023-2024
FAFSA's Data Loaded	33,561	39,713

- **Future Outlook:**

- DOE “processing” issues should be resolved by end of May.
- We should be able to start awarding the first two weeks of June.
- Alamo staff augmentation in place to handle compressed workload.
- Student aid packages will be finalized well before fall term begins.



FY23 Single Audit Results

Patrick Vrba
District Controller

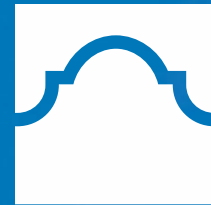

ALAMO
COLLEGES
DISTRICT



Purpose

- To communicate the results of the FY23 Single Audit to the Board of Trustees.
- A Single Audit is a compliance audit over the District's portfolio of Federal and State grants, required under the *Uniform Guidance* published by the Office of Management and Budget (OMB) and the *Texas Grant Management Standards* published by the Texas Comptroller, respectively.
- The FY23 Financial Statement audit was approved by the Board in December.



Single Audit Results Overview

Single Audit: Compliance Audit of Federal and State Programs (Grants)

	Grants Subcategory	FY23 Expenses	# of Grants	# of Findings	Questioned Costs
*	Student Financial Aid Cluster - Federal	\$ 114,787,852	4	1	\$0.00
*	HEERF Grants - Federal	84,799,565	16	1	\$0.00
	Other Grants - Federal	19,685,920	27	-	\$0.00
	Total Grants - Federal	\$ 219,273,337	47	2	\$0.00
*	Texas Educational Opportunity Grant - State	\$ 4,859,982	1	-	\$0.00
	Other Grants - State	1,578,871	17	-	\$0.00
	Total Grants - State	\$ 6,438,853	18	-	\$0.00
	Total Federal and State Grants	\$ 225,712,190	65	2	\$0.00

* Audited in FY23



Student Financial Aid Cluster

Single Audit Finding #1

- **Unmodified (clean) opinion on compliance issued for Student Financial Aid grants**
- **Finding (1):**
 - There was no review of the Enterprise Data Governance Standard to verify the implementation of one of 8 required safeguards under the Gramm-Leach-Bliley-Act.
 - **No improper awards were distributed**, finding was related to missing language in the District's written information security policies and procedures specifying the responsibility and performance of an annual data inventory of financial records.
 - Considered to be a *significant deficiency* in internal control over compliance
 - There were **no questioned costs**, not related to any financial aid awards issued
- **Corrective action plan:**
 - IT policy documents will be updated to include the required language (in progress)
 - Annual data inventory required under the GLBA will be performed prior to 8/31/24



Higher Education Emergency Relief Funds (HEERF)

Single Audit Finding #2

- **Unmodified (clean) opinion on compliance issued for HEERF grants**
- **Finding (1):**
 - For (2) HEERF awards made during the fiscal year, the applications did not go through the advocacy centers in accordance with established *internal* policies
 - There were no violations of HEERF grant requirements or any federal regulations
 - Considered to be a *significant deficiency* in internal control over compliance
- **Corrective action plan:**
 - Changes to the financial aid Board policy were made and implemented, including training staff on those changes



Thank you.

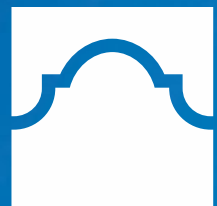

ALAMO
COLLEGES
DISTRICT



**INDEPENDENT AUDITORS' REPORT ON INTERNAL CONTROL OVER
FINANCIAL REPORTING AND ON COMPLIANCE AND OTHER MATTERS
BASED ON AN AUDIT OF FINANCIAL STATEMENTS PERFORMED
IN ACCORDANCE WITH *GOVERNMENT AUDITING STANDARDS***

Board of Directors
Alamo Community College District
San Antonio, Texas

We have audited, in accordance with the auditing standards generally accepted in the United States of America and the standards applicable to financial audits contained in *Government Auditing Standards* issued by the Comptroller General of the United States, the financial statements of the business-type activities and the discretely presented component units of Alamo Community College District (The District) as of and for the year ended August 31, 2023, and the related notes to the financial statements, which collectively comprise The District's basic financial statements, and have issued our report thereon dated REPORT DATE.

Report on Internal Control Over Financial Reporting

In planning and performing our audit of the financial statements, we considered The District's internal control over financial reporting (internal control) as a basis for designing audit procedures that are appropriate in the circumstances for the purpose of expressing our opinions on the financial statements, but not for the purpose of expressing an opinion on the effectiveness of The District's internal control. Accordingly, we do not express an opinion on the effectiveness of The District's internal control.

A deficiency in internal control exists when the design or operation of a control does not allow management or employees, in the normal course of performing their assigned functions, to prevent, or detect and correct, misstatements on a timely basis. A material weakness is a deficiency, or a combination of deficiencies, in internal control, such that there is a reasonable possibility that a material misstatement of the entity's financial statements will not be prevented, or detected and corrected, on a timely basis. A significant deficiency is a deficiency, or a combination of deficiencies, in internal control that is less severe than a material weakness, yet important enough to merit attention by those charged with governance.

Our consideration of internal control was for the limited purpose described in the first paragraph of this section and was not designed to identify all deficiencies in internal control that might be material weaknesses or significant deficiencies. Given these limitations, during our audit we did not identify any deficiencies in internal control that we consider to be material weaknesses. However, material weaknesses or significant deficiencies may exist that were not identified.

Report on Compliance and Other Matters

As part of obtaining reasonable assurance about whether The District’s financial statements are free from material misstatement, we performed tests of its compliance with certain provisions of laws, regulations, contracts, and grant agreements, noncompliance with which could have a direct and material effect on the financial statements. However, providing an opinion on compliance with those provisions was not an objective of our audit, and accordingly, we do not express such an opinion. The results of our tests disclosed no instances of noncompliance or other matters that are required to be reported under *Government Auditing Standards*.

Purpose of This Report

The purpose of this report is solely to describe the scope of our testing of internal control and compliance and the results of that testing, and not to provide an opinion on the effectiveness of the entity’s internal control or on compliance. This report is an integral part of an audit performed in accordance with *Government Auditing Standards* in considering the entity’s internal control and compliance. Accordingly, this communication is not suitable for any other purpose.

CliftonLarsonAllen LLP

San Antonio, Texas
REPORT DATE

DRAFT

INDEPENDENT AUDITORS' REPORT ON COMPLIANCE FOR EACH MAJOR FEDERAL PROGRAM AND REPORT OVER INTERNAL CONTROL OVER COMPLIANCE, AND REPORT ON THE SCHEDULE OF EXPENDITURES OF FEDERAL AWARDS REQUIRED BY THE UNIFORM GUIDANCE

Board of Directors
Alamo Community College District
San Antonio, Texas

Report on Compliance for Each Major Federal Program

Opinion on Each Major Federal Program

We have audited Alamo Community College District's (The District) compliance with the types of compliance requirements identified as subject to audit in the OMB *Compliance Supplement* that could have a direct and material effect on each of the District's major federal programs for the year ended August 31, 2023. The District's federal programs are identified in the summary of auditors' results section of the accompanying schedule of findings and questioned costs.

In our opinion, The District complied, in all material respects, with the compliance requirements referred to above that could have a direct and material effect on each of its major federal programs for the year ended August 31, 2023.

Basis for Opinion on Each Major Federal Program

We conducted our audit of compliance in accordance with auditing standards generally accepted in the United States of America (GAAS); the standards applicable to financial audits contained in *Government Auditing Standards* issued by the Comptroller General of the United States; and the audit requirements of Title 2 U.S. *Code of Federal Regulations* Part 200, *Uniform Administrative Requirements, Cost Principles, and Audit Requirements for Federal Awards* (Uniform Guidance). Our responsibilities under those standards and the Uniform Guidance are further described in the Auditors' Responsibilities for the Audit of Compliance section of our report.

We are required to be independent of The District and to meet our other ethical responsibilities, in accordance with relevant ethical requirements relating to our audit. We believe that the audit evidence we have obtained is sufficient and appropriate to provide a basis for our opinion on compliance for each major federal program. Our audit does not provide a legal determination of The District's compliance with the compliance requirements referred to above.

Responsibilities of Management for Compliance

Management is responsible for compliance with the requirements referred to above and for the design, implementation, and maintenance of effective internal control over compliance with the requirements of laws, statutes, regulations, rules and provisions of contracts or grant agreements applicable to The District's federal programs.

Auditors' Responsibilities for the Audit of Compliance

Our objectives are to obtain reasonable assurance about whether material noncompliance with the compliance requirements referred to above occurred, whether due to fraud or error, and express an opinion on The District's compliance based on our audit. Reasonable assurance is a high level of assurance but is not absolute assurance and therefore is not a guarantee that an audit conducted in accordance with GAAS, *Government Auditing Standards*, and the Uniform Guidance will always detect material noncompliance when it exists. The risk of not detecting material noncompliance resulting from fraud is higher than for that resulting from error, as fraud may involve collusion, forgery, intentional omissions, misrepresentations, or the override of internal control. Noncompliance with the compliance requirements referred to above is considered material if there is a substantial likelihood that, individually or in the aggregate, it would influence the judgment made by a reasonable user of the report on compliance about The District's compliance with the requirements of each major federal program as a whole.

In performing an audit in accordance with GAAS, *Government Auditing Standards*, and the Uniform Guidance, we:

- Exercise professional judgment and maintain professional skepticism throughout the audit.
- Identify and assess the risks of material noncompliance, whether due to fraud or error, and design and perform audit procedures responsive to those risks. Such procedures include examining, on a test basis, evidence regarding The District's compliance with the compliance requirements referred to above and performing such other procedures as we considered necessary in the circumstances.
- Obtain an understanding of The District's internal control over compliance relevant to the audit in order to design audit procedures that are appropriate in the circumstances and to test and report on internal control over compliance in accordance with the Uniform Guidance, but not for the purpose of expressing an opinion on the effectiveness of The District's internal control over compliance. Accordingly, no such opinion is expressed.

We are required to communicate with those charged with governance regarding, among other matters, the planned scope and timing of the audit and any significant deficiencies and material weaknesses in internal control over compliance that we identified during the audit.

Other Matters

The results of our auditing procedures disclosed instances of noncompliance, which are required to be reported in accordance with the Uniform Guidance and which are described in the accompanying schedule of findings and questioned costs as items 2023-001 and 2023-002. Our opinion on each major federal program is not modified with respect to these matters.

Government Auditing Standards requires the auditor to perform limited procedures on The District's response to the noncompliance findings identified in our compliance audit described in the accompanying schedule of findings and questioned costs. The District's response was not subjected to the other auditing procedures applied in the audit of compliance and, accordingly, we express no opinion on the response.

Report on Internal Control Over Compliance

Our consideration of internal control over compliance was for the limited purpose described in the Auditors' Responsibilities for the Audit of Compliance section above and was not designed to identify all deficiencies in internal control over compliance that might be material weaknesses or significant deficiencies in internal control over compliance and therefore, material weaknesses or significant deficiencies may exist that were not identified. We did not identify any deficiencies in internal control over compliance that we consider to be material weaknesses. However, as discussed below, we did identify certain deficiencies in internal control over compliance that we consider to be significant deficiencies.

A deficiency in internal control over compliance exists when the design or operation of a control over compliance does not allow management or employees, in the normal course of performing their assigned functions, to prevent, or detect and correct, noncompliance with a type of compliance requirement of a federal program on a timely basis. *A material weakness in internal control over compliance* is a deficiency, or a combination of deficiencies, in internal control over compliance, such that there is a reasonable possibility that material noncompliance with a type of compliance requirement of a federal program will not be prevented, or detected and corrected, on a timely basis. *A significant deficiency in internal control over compliance* is a deficiency, or a combination of deficiencies, in internal control over compliance with a type of compliance requirement of a federal program that is less severe than a material weakness in internal control over compliance, yet important enough to merit attention by those charged with governance. We consider the deficiencies in internal control over compliance described in the accompanying schedule of findings and questioned costs as items 2023-001 and 2023-002, to be significant deficiencies.

Our audit was not designed for the purpose of expressing an opinion on the effectiveness of internal control over compliance. Accordingly, no such opinion is expressed.

Government Auditing Standards requires the auditor to perform limited procedures on The District's response to the internal control over compliance findings identified in our audit described in the accompanying schedule of findings and questioned costs. The District's response was not subjected to the other auditing procedures applied in the audit of compliance and, accordingly, we express no opinion on the response.

The purpose of this report on internal control over compliance is solely to describe the scope of our testing of internal control over compliance and the results of that testing based on the requirements of the Uniform Guidance. Accordingly, this report is not suitable for any other purpose.

Report on Schedule of Expenditures of Federal Awards Required by the Uniform Guidance

We have audited the financial statements of the governmental activities, the business-type activities and the aggregate discretely presented component units of The District's as of and for the year ended August 31, 2023, and the related notes to the financial statements, which collectively comprise Alamo Community College District's basic financial statements. We have issued our report thereon, dated REPORT DATE, which contained unmodified opinions on those financial statements. Our audit was conducted for the purpose of forming opinions on the financial statements that collectively comprise the basic financial statements. The accompanying schedule of expenditures of federal awards is presented for purposes of additional analysis as required by the Uniform Guidance and is not a required part of the basic financial statements. Such information is the responsibility of management and was derived from and relates directly to the underlying accounting and other records used to prepare the basic financial statements. The information has been subjected to the auditing procedures applied in the audit of the basic financial statements and certain additional procedures, including comparing and reconciling such information directly to the underlying accounting and other records used to prepare the basic financial statements or to the basic financial statements themselves, and other additional procedures in accordance with auditing standards generally accepted in the United States of America. In our opinion, the schedule of expenditures of federal awards is fairly stated in all material respects in relation to the basic financial statements as a whole.

CliftonLarsonAllen LLP

San Antonio, Texas
REPORT DATE

DRAFT

**ALAMO COMMUNITY COLLEGE DISTRICT
SCHEDULE OF FINDINGS AND QUESTIONED COSTS
YEAR ENDED AUGUST 31, 2023**

Section I – Summary of Auditors’ Results

Financial Statements

1. Type of auditors’ report issued: Unmodified
2. Internal control over financial reporting:
- Material weakness(es) identified? _____ yes _____ x no
 - Significant deficiency(ies) identified that are not considered to be material weakness(es)? _____ yes _____ x none reported
3. Noncompliance material to financial statements noted? _____ yes _____ x no

Federal Awards

1. Internal control over audited federal programs:
- Material weakness(es) identified? _____ yes _____ x no
 - Significant deficiency(ies) identified that are not considered to be material weakness(es)? _____ x yes _____ none reported
2. Type of auditors’ report issued on compliance for audited federal programs: Unmodified
3. Any audit findings disclosed that are required to be reported in accordance with 2 CFR 200.516(a)? _____ x yes _____ no

Identification of Audited Programs

Assistance Listing Number(s)

Various
84.425

Name of Federal Program or Cluster

Student Financial Assistance Cluster
Education Stabilization Fund

Dollar threshold used to distinguish between Type A and Type B programs:

Type A - \$3,000,000

Auditee qualified as low-risk auditee?

_____ yes _____ x no

**ALAMO COMMUNITY COLLEGE DISTRICT
SCHEDULE OF FINDINGS AND QUESTIONED COSTS (CONTINUED)
YEAR ENDED AUGUST 31, 2023**

Section II – Financial Statement Findings

Our audit did not disclose any matters required to be reported in accordance with *Government Auditing Standards*.

Section III – Findings and Questioned Costs

2023-001 Gramm-Leach-Bliley Act (GLBA)

Federal Agency: Department of Education
Federal Program: Student Financial Assistance Cluster
Assistance Listing Numbers: 84.007 – Federal Supplemental Education Opportunity Grants
84.033 – Federal Work Study Program
84.038 – Federal Perkins Loans
84.063 – Federal Pell Grant Program
84.268 – Federal Direct Student Loans

Federal Award Identification Number and Year: N/A

Award Period: September 1, 2022 to August 31, 2023

Type of Finding:

- Significant Deficiency in Internal Control Over Compliance
- Other Matters

Criteria or Specific Requirement: The Gramm-Leach-Bliley Act (Public Law 106-102) requires financial institutions to explain their information-sharing practices to their customers and to safeguard sensitive data. (16 CFR 314) The Federal Trade Commission considers Title IV-eligible institutions that participate in Title IV Educational Assistance Programs as “financial institutions” and subject to the Gramm-Leach-Bliley Act (16 CFR 313.3(k)(2)(vi).

In addition, per Uniform Guidance 2 CFR 200.303, federal entities receiving federal awards are required to establish and maintain internal controls designed to reasonably ensure compliance with federal laws, regulations and program compliance requirements.

Condition: Under an institution’s Program Participation Agreement with the Department of Education and the Gramm-Leach-Bliley Act, schools must protect student financial aid information, with particular attention to information provided to institutions by the Department or otherwise obtained in support of the administration of the federal student financial aid programs.

Questioned Costs: None

Context: During our review of the GLBA reports for Alamo Community College District, we noted there was no review of the written information security plan (District’s Enterprise Data Governance Standard) to verify the implementation of one of the eight required GLBA safeguards.

Cause: The Enterprise Data Governance Standard did not include one of the required GLBA safeguards.

**ALAMO COMMUNITY COLLEGE DISTRICT
SCHEDULE OF FINDINGS AND QUESTIONED COSTS (CONTINUED)
YEAR ENDED AUGUST 31, 2023**

Section III – Findings and Questioned Costs (Continued)

2023-001 Gramm-Leach-Bliley Act (GLBA) (Continued)

Effect: The District is not in full compliance with GLBA.

Repeat Finding: No

Recommendation: We recommend that the District review the updated GLBA requirements and ensure their Enterprise Data Governance Standard includes all required elements.

Views of Responsible Officials: There is no disagreement with the audit finding. See corrective action plan.

2023-002 Higher Education Emergency Relief Funds (HEERF)

Federal Agency: Department of Education
Federal Program: Education Stabilization Fund
Assistance Listing Number: 84.425E

Federal Award Identification Number and Year: N/A

Award Period: September 1, 2022 to August 31, 2023

Type of Finding:

- Significant Deficiency in Internal Control Over Compliance
- Other Matters

Criteria or Specific Requirement: In accordance with 2 CFR Section 200.407, institutions distributing HEERF funding are required to ensure that students meet the eligibility requirements of the program.

In addition, per Uniform Guidance 2 CFR 200.303, federal entities receiving federal awards are required to establish and maintain internal controls designed to reasonably ensure compliance with federal laws, regulations and program compliance requirements.

Condition: During our testing of student expenditures of HEERF funding, we identified certain internal control policies of the District were not followed.

Questioned Costs: None

**ALAMO COMMUNITY COLLEGE DISTRICT
SCHEDULE OF FINDINGS AND QUESTIONED COSTS (CONTINUED)
YEAR ENDED AUGUST 31, 2023**

Section III – Findings and Questioned Costs (Continued)

2023-002 Higher Education Emergency Relief Funds (HEERF) (Continued)

Context: During our testing of the HEERF student expenditures, we identified certain instances where internal control policies of the District were not followed at Northwest Vista College.

Cause: The District in certain instances did not follow the internal control policies implemented around the awarding of HEERF student funds.

Effect: There were certain instances where HEERF funds were disbursed that did not follow the District's internal control policies.

Repeat Finding: No

Recommendation: We recommend that the District review their internal processes and ensure all internal control policies are followed.

Views of Responsible Officials: There is no disagreement with the audit finding. See corrective action plan.

DRAFT

**INDEPENDENT AUDITORS' REPORT ON COMPLIANCE FOR
EACH MAJOR STATE PROGRAM AND REPORT ON INTERNAL CONTROL OVER
COMPLIANCE, AND REPORT ON THE SCHEDULE OF EXPENDITURES OF STATE AWARDS
REQUIRED BY THE TEXAS GRANT MANAGEMENT STANDARDS**

Board of Directors
Alamo Community College District

Report on Compliance for Each Major State Program

Opinion on Each Major State Program

We have audited Alamo Community College District's (the District) compliance with the types of compliance requirements identified as subject to audit in the Texas Grant Management Standards that could have a direct and material effect on each of the District's major state programs for the year ended August 31, 2023. The District's major state programs are identified in the summary of auditors' results section of the accompanying state schedule of findings and questioned costs.

In our opinion, the District complied, in all material respects, with the compliance requirements referred to above that could have a direct and material effect on each of its major state programs for the year ended August 31, 2023.

Basis for Opinion on Each Major State Program

We conducted our audit of compliance in accordance with auditing standards generally accepted in the United States of America (GAAS); the standards applicable to financial audits contained in *Government Auditing Standards* issued by the Comptroller General of the United States (*Government Auditing Standards*); and the audit requirements of the Texas Grant Management Standards (TxGMS). Our responsibilities under those standards and the TxGMS are further described in the Auditors' Responsibilities for the Audit of Compliance section of our report.

We are required to be independent of the District and to meet our other ethical responsibilities, in accordance with relevant ethical requirements relating to our audit. We believe that the audit evidence we have obtained is sufficient and appropriate to provide a basis for our opinion on compliance for each major state program. Our audit does not provide a legal determination of the District's compliance with the compliance requirements referred to above.

Responsibilities of Management for Compliance

Management is responsible for compliance with the requirements referred to above and for the design, implementation, and maintenance of effective internal control over compliance with the requirements of laws, statutes, regulations, rules and provisions of contracts or grant agreements applicable to the District's state programs.

Auditors' Responsibilities for the Audit of Compliance

Our objectives are to obtain reasonable assurance about whether material noncompliance with the compliance requirements referred to above occurred, whether due to fraud or error, and express an opinion on the District's compliance based on our audit. Reasonable assurance is a high level of assurance but is not absolute assurance and therefore is not a guarantee that an audit conducted in accordance with GAAS, *Government Auditing Standards*, and the TxGMS will always detect material noncompliance when it exists. The risk of not detecting material noncompliance resulting from fraud is higher than for that resulting from error, as fraud may involve collusion, forgery, intentional omissions, misrepresentations, or the override of internal control. Noncompliance with the compliance requirements referred to above is considered material, if there is a substantial likelihood that, individually or in the aggregate, it would influence the judgment made by a reasonable user of the report on compliance about the District's compliance with the requirements of each major state program as a whole.

In performing an audit in accordance with GAAS, *Government Auditing Standards*, and the TxGMS, we:

- Exercise professional judgment and maintain professional skepticism throughout the audit.
- Identify and assess the risks of material noncompliance, whether due to fraud or error, and design and perform audit procedures responsive to those risks. Such procedures include examining, on a test basis, evidence regarding the District's compliance with the compliance requirements referred to above and performing such other procedures as we considered necessary in the circumstances.
- Obtain an understanding of the District's internal control over compliance relevant to the audit in order to design audit procedures that are appropriate in the circumstances and to test and report on internal control over compliance in accordance with the TxGMS, but not for the purpose of expressing an opinion on the effectiveness the District's internal control over compliance. Accordingly, no such opinion is expressed.

We are required to communicate with those charged with governance regarding, among other matters, the planned scope and timing of the audit and any significant deficiencies and material weaknesses in internal control over compliance that we identified during the audit.

Report on Internal Control Over Compliance

A deficiency in internal control over compliance exists when the design or operation of a control over compliance does not allow management or employees, in the normal course of performing their assigned functions, to prevent, or detect and correct, noncompliance with a type of compliance requirement of a state program on a timely basis. A material weakness in internal control over compliance is a deficiency, or a combination of deficiencies, in internal control over compliance, such that there is a reasonable possibility that material noncompliance with a type of compliance requirement of a state program will not be prevented, or detected and corrected, on a timely basis. A significant deficiency in internal control over compliance is a deficiency, or a combination of deficiencies, in internal control over compliance with a type of compliance requirement of a state program that is less severe than a material weakness in internal control over compliance, yet important enough to merit attention by those charged with governance.

Our consideration of internal control over compliance was for the limited purpose described in the Auditors' Responsibilities for the Audit of Compliance section above and was not designed to identify all deficiencies in internal control over compliance that might be material weaknesses or significant deficiencies in internal control over compliance. Given these limitations, during our audit we did not identify any deficiencies in internal control over compliance that we consider to be material weaknesses, as defined above. However, material weaknesses or significant deficiencies in internal control over compliance may exist that were not identified.

Our audit was not designed for the purpose of expressing an opinion on the effectiveness of internal control over compliance. Accordingly, no such opinion is expressed.

The purpose of this report on internal control over compliance is solely to describe the scope of our testing of internal control over compliance and the results of that testing based on the requirements of the TxGMS. Accordingly, this report is not suitable for any other purpose.

Report on Schedule of Expenditures of State Awards Required by the Texas Grant Management Standards

We have audited the financial statements of the governmental activities, the business-type activities and the aggregate discretely presented component units of The District's as of and for the year ended August 31, 2023, and the related notes to the financial statements, which collectively comprise Alamo Community College District's basic financial statements. We have issued our report thereon, dated REPORT DATE, which contained unmodified opinions on those financial statements. Our audit was conducted for the purpose of forming opinions on the financial statements that collectively comprise the basic financial statements. The accompanying schedule of expenditures of federal awards is presented for purposes of additional analysis as required by the Texas Grant Management Standards and is not a required part of the basic financial statements. Such information is the responsibility of management and was derived from and relates directly to the underlying accounting and other records used to prepare the basic financial statements. The information has been subjected to the auditing procedures applied in the audit of the basic financial statements and certain additional procedures, including comparing and reconciling such information directly to the underlying accounting and other records used to prepare the basic financial statements or to the basic financial statements themselves, and other additional procedures in accordance with auditing standards generally accepted in the United States of America. In our opinion, the schedule of expenditures of federal awards is fairly stated in all material respects in relation to the basic financial statements as a whole.

Board of Directors
Alamo Community College District

CliftonLarsonAllen LLP

San Antonio, Texas
REPORT DATE

DRAFT

**ALAMO COMMUNITY COLLEGE DISTRICT
STATE SCHEDULE OF FINDINGS AND QUESTIONED COSTS
YEAR ENDED AUGUST 31, 2023**

Section I – Summary of Auditors’ Results

Financial Statements

1. Type of auditors’ report issued: Unmodified
2. Internal control over financial reporting:
- Material weakness(es) identified? _____ yes x no
 - Significant deficiency(ies) identified that are not considered to be material weakness(es)? _____ yes x none reported
3. Noncompliance material to financial statements noted? _____ yes x no

State Awards

1. Internal control over audited state programs:
- Material weakness(es) identified? _____ yes x no
 - Significant deficiency(ies) identified that are not considered to be material weakness(es)? _____ yes x none reported
2. Type of auditors’ report issued on compliance for audited federal programs: Unmodified
3. Any audit findings disclosed that are required to be reported in accordance with *Texas Grant Management Standards*? _____ yes x no

Identification of Audited Programs

Contract Number

N/A

Name of State Program or Cluster

Texas Educational Opportunity Grant

Dollar threshold to distinguish
Between type A and type B programs:

\$750,000

Auditee qualified as low-risk auditee?

 x yes _____ no

ALAMO COMMUNITY COLLEGE DISTRICT
STATE SCHEDULE OF FINDINGS AND QUESTIONED COSTS (CONTINUED)
YEAR ENDED AUGUST 31, 2023

Section II – Financial Statement Findings

No financial statement findings.

Section III – State Award Findings and Questioned Costs

No state award findings and questioned costs.

Section IV – Prior Year Audit Findings

See summary of prior audit findings.

DRAFT

Discussion and Possible Action on the Annual Debt Management Plan for FY25

Sean Mullen, CTP, CFP
Treasurer
Finance & Fiscal Services

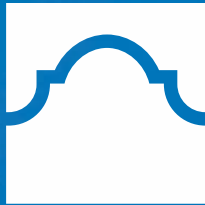

ALAMO
COLLEGES
DISTRICT



Action Requested

Approve the recommendation as presented in the FY2025 Debt Management Plan. The Chancellor or his designee is directed to authorize the District's outside consultants to prepare any documents that may be necessary for Board approval.



Thank you.

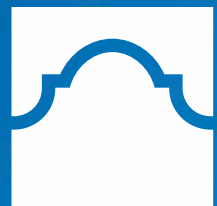

ALAMO
COLLEGES
DISTRICT



FY 2025 Debt Management Plan

Sean Mullen, CTP, CFP®
Treasurer
Finance & Fiscal Services

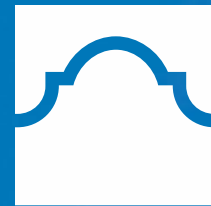

ALAMO
COLLEGES
DISTRICT



Malcolm Baldrige
National Quality Award
2018 Award Recipient



Board Policies in Support of Charges

C.3.1 Debt Management

- *To ensure prudent debt management practices*

Charges to the Chancellor

Monitored Goals

- *General Obligation Bonds and Maintenance Tax Notes*



Alamo Colleges District is one of only 3 Community College Districts in Texas and 10 Nationally with AAA/Aaa ratings from both Standard & Poor's (S&P) and Moody's



Agenda

- Overview of Alamo's Debt/Tax Rate
- Debt Management Goals & Long Range Planning
- Recommended FY 2025 Plan
- Next Steps



Debt Portfolio and Tax Rate

Total Debt: \$790.3 Million

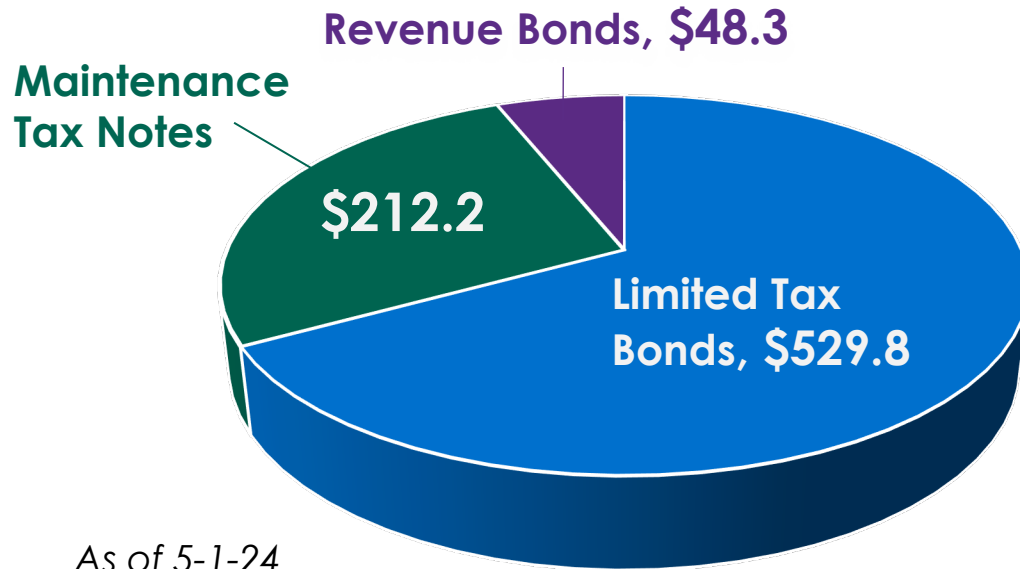

Alamo Colleges District Tax Rate

Current Property
Tax Rate =
\$0.14915

\$0.10776 goes
to Operations
(M&O)

\$0.04139 goes
to pay Debt
(I&S)

As of 5-1-24

Detailed information presented in:
Annual Budget Book
Annual Comprehensive Financial Report



Debt Management Goals & Long Range Planning



Goals

1. Manage Tax Rate through:
 - Strategic Issuances
 - Paying off debt early (Defeasance)
 - Refinancing our debt for better rates (Refunding)
2. Maintaining our AAA/Aaa bond ratings through management of amount of leveraged debt
3. Manage capacity to allow for future needed debt issuance

Property Value Growth: **NO CHANGE IN TAX RATE**

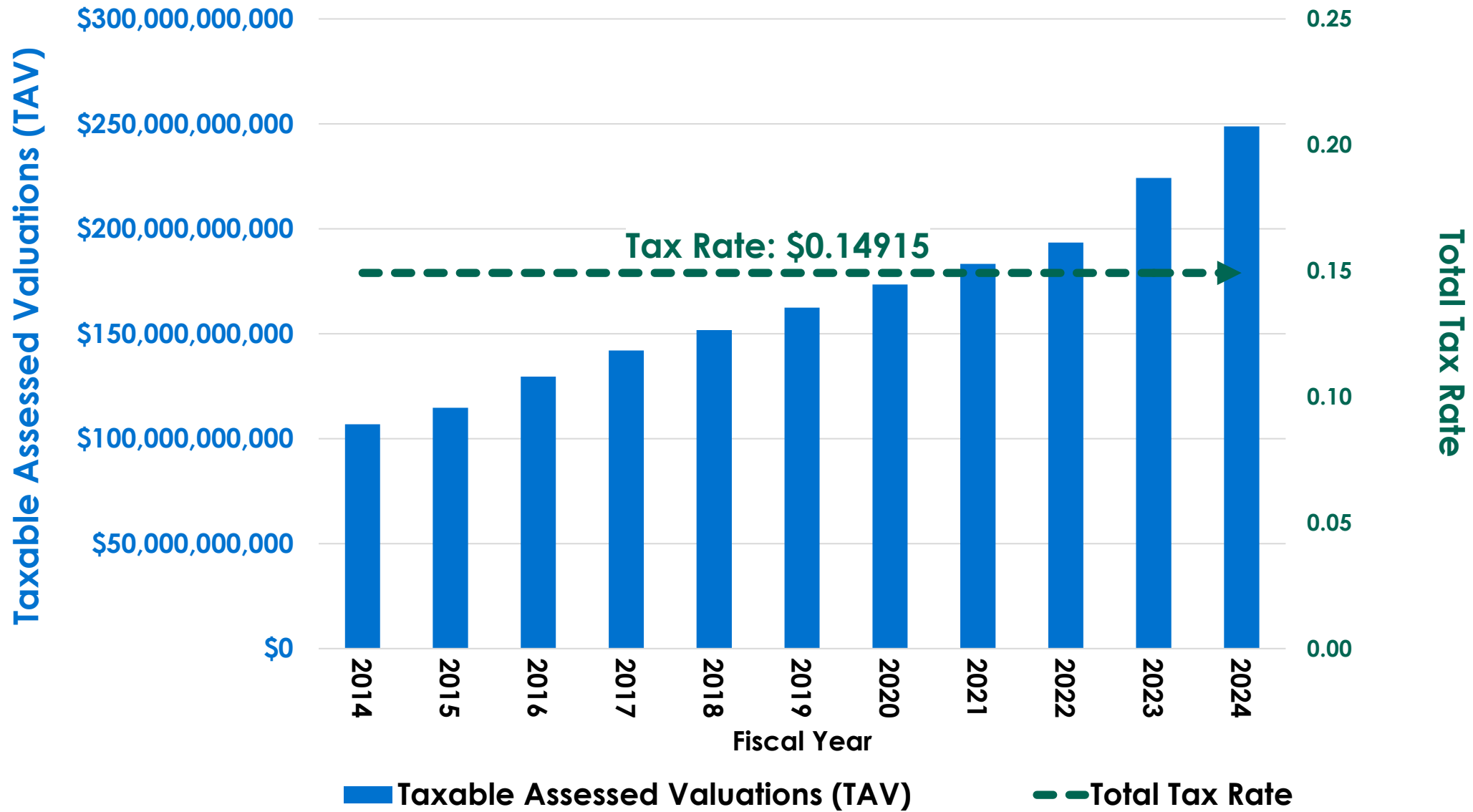

Managing Debt Capacity & Stable Tax Rate

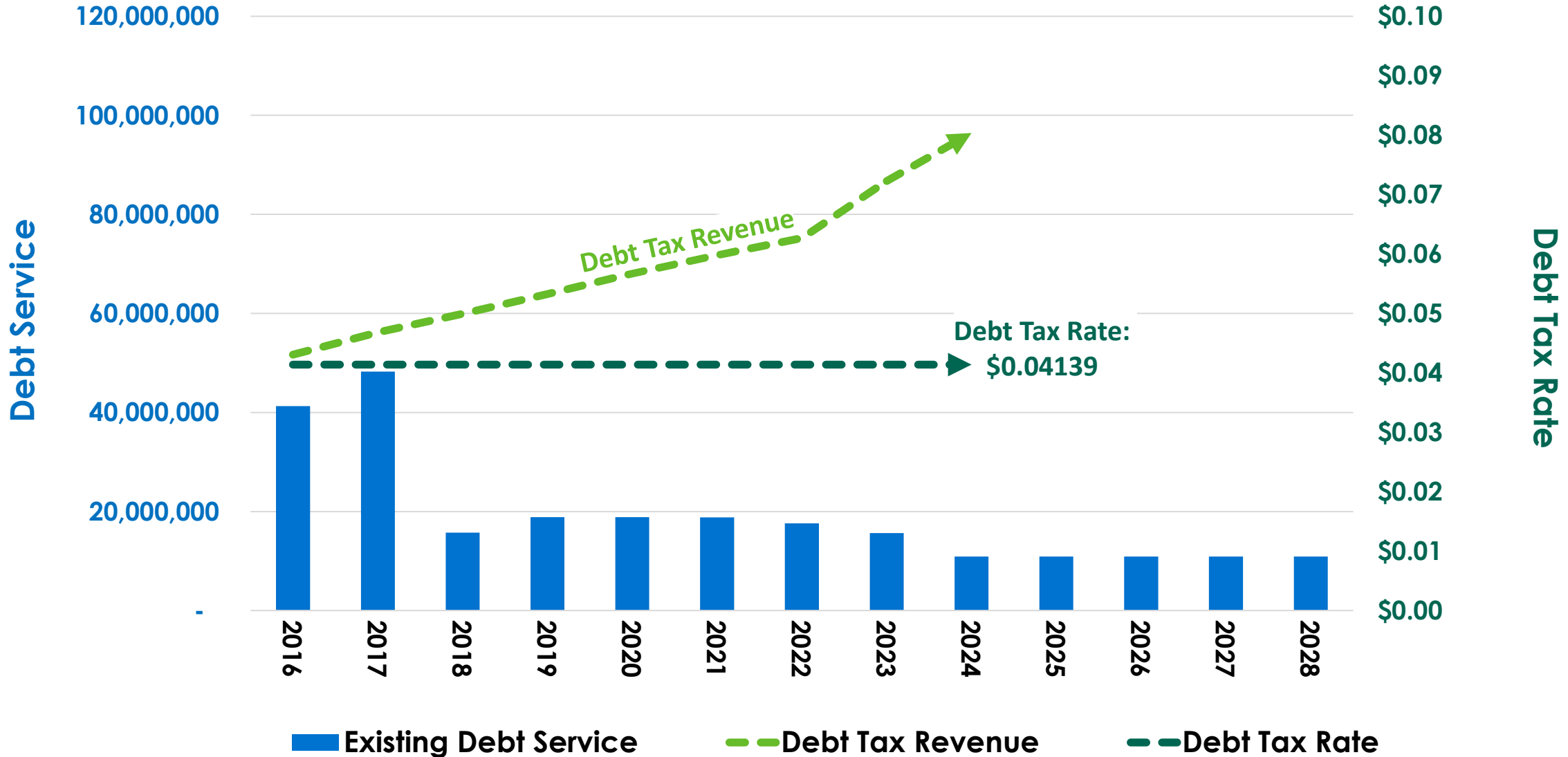

Managing Debt Capacity & Stable Tax Rate

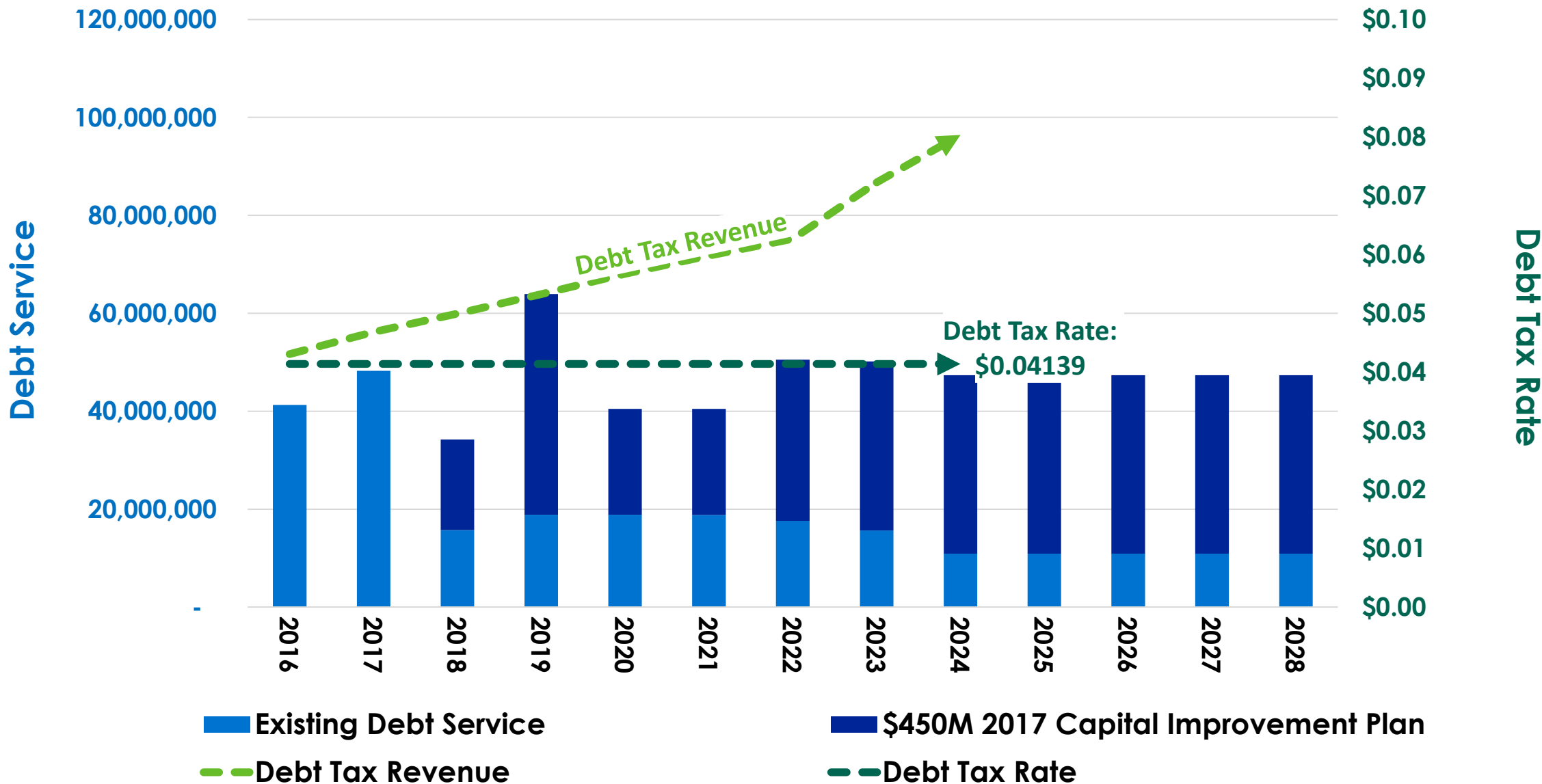

Managing Debt Capacity & Stable Tax Rate

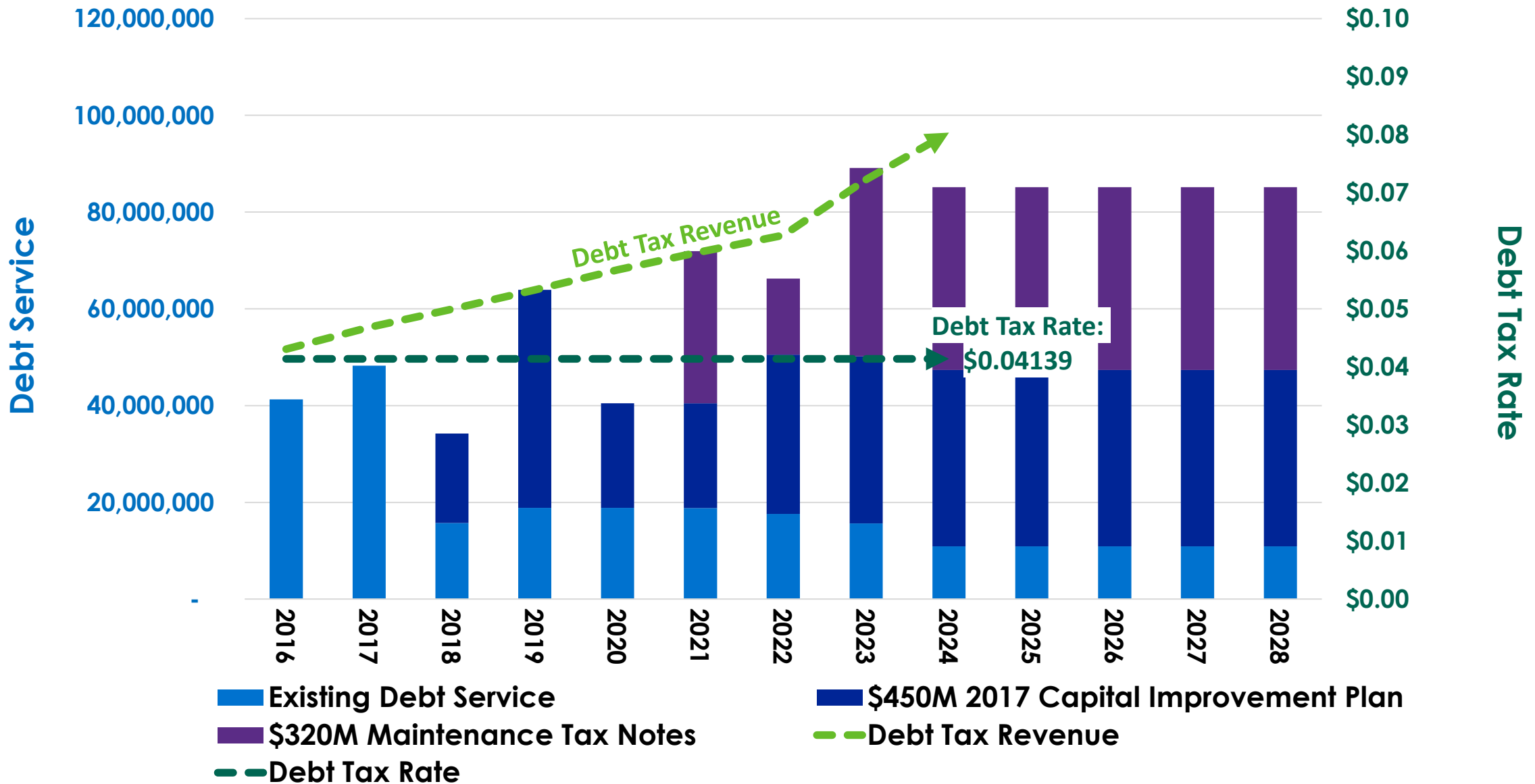

Managing Debt Capacity & Stable Tax Rate

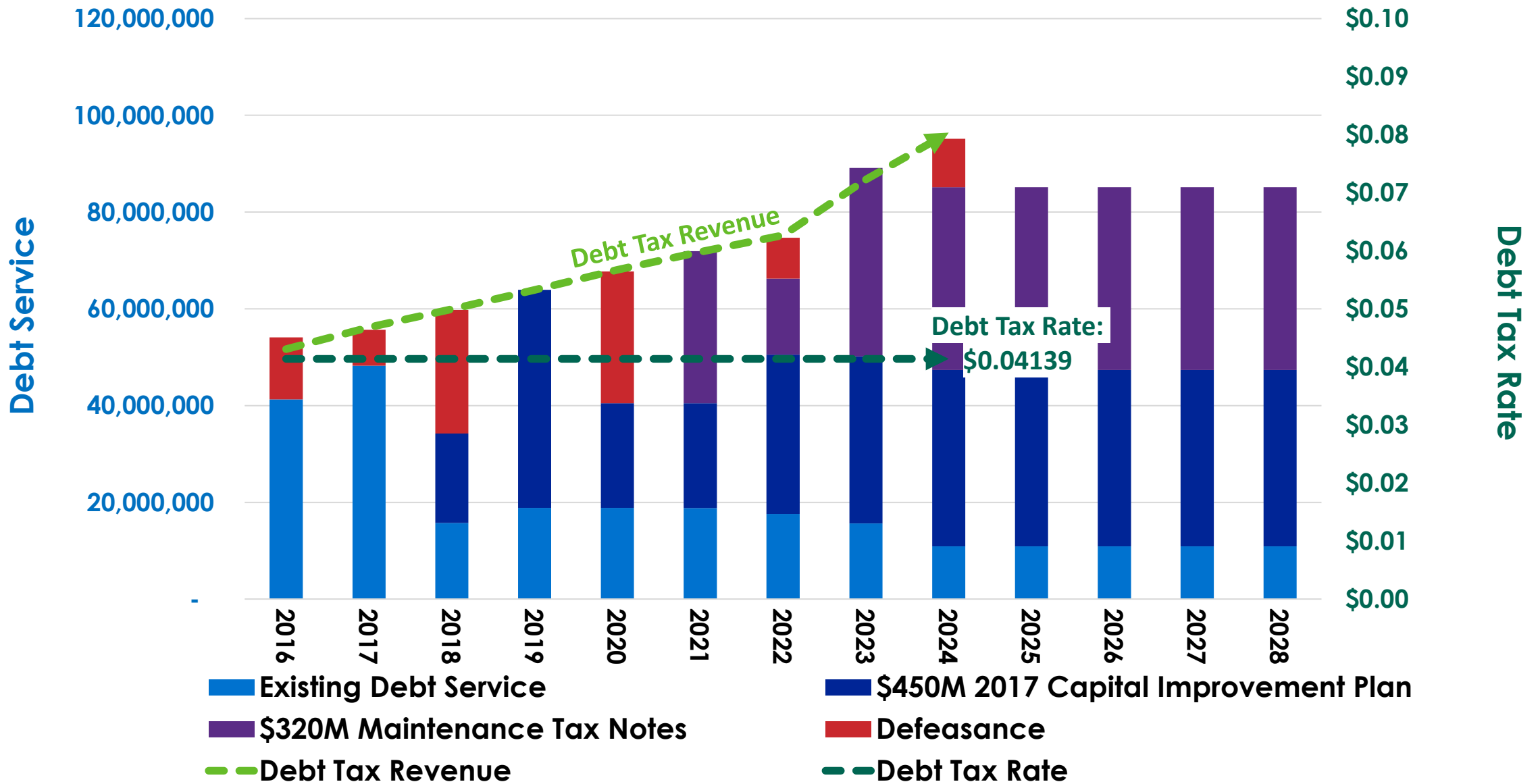

Managing Debt Capacity & Stable Tax Rate

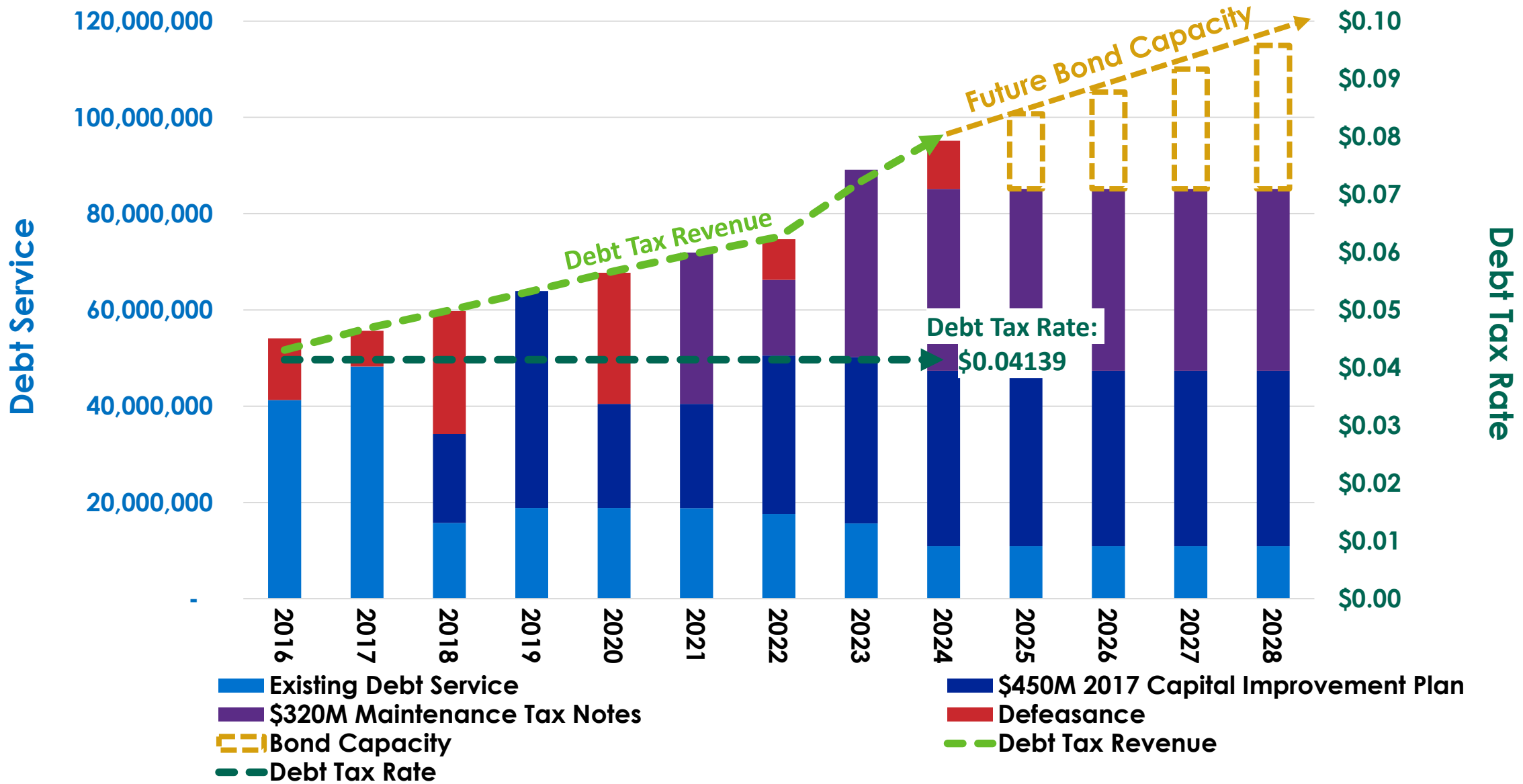

FY 2025 Debt Management Plan



Recommendations FY 2025 Debt Mgmt. Plan

1. Defease up to \$20 million of the District's callable bonds

- Current estimated Net Present Value savings \$9 million on \$19.7 million defeasance
- Continue to level off future Limited Tax debt service requirements
- Mechanism to manage our tax rate and create capacity for future issuances

2. Monitor refunding opportunities for existing bonds

- \$46 million currently available for refunding + \$40 million becoming available in November 2024
- Current estimate of \$5.6 million in Net Present Value savings (~6% of par amount)

Savings estimates as of 4-08-24



Future Voter Bond Authorization

Assumptions:

- Continue current plan of defeasing bonds over next 2 years
- We expect moderate growth in Property Values
- Capacity for Bond Election in 2025
- **No increase to debt tax rate**



Next Steps – Board Action Needed

May 2024 Board Action Requested for:

- Approval of FY 2025 Debt Management Plan
- Approval of Annual Review of Debt Mgt. Policy (no changes)

Future Board Action Needed (August 2024):

- Parameter Order for Ltd. Tax Defeasance (FY 2025) to allow for prepayment of outstanding debt

Thank you.

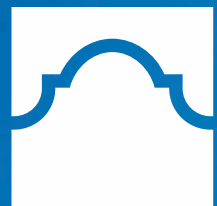

ALAMO
COLLEGES
DISTRICT



Debt Management Team

- Alamo Colleges District Staff
 - Lisa L Mazure, MSA, CPA
 - Ross Laughead, JD
 - Sean Mullen, CTP, CFP
- Hilltop Securities- Municipal Advisor
 - Raul Villasenor, Managing Director
 - Michelle Aragon, Director
- Norton Rose Fulbright US LLP- Bond Counsel
 - Stephanie Leibe, Partner
 - Matt Lee, Sr. Associate



Status of FY 2024 Plan (May 2023)

- Plan: **Add “Method of Sale” section to Debt Mgt. Policy**
 - ✓ Done; May 2023
- Plan: **Establish new Underwriting Pool**
 - ✓ Done; July 2023; 14 firms selected
- Plan: **Maintain stable tax rate**
 - ✓ Done; No rate change for FY 2024 (Tax Year 2023)
- Plan: **Defeasance % of Series 2012 Ltd. Tax Bonds**
 - ✓ Done; Parameter Order approved August 2023
 - ❑ Pending; Up to \$15.35M defeasance to occur by August 2024
- Plan: **Monitor current refunding opportunities**
 - On-going; No refundings were completed in FY23 as the estimated savings did not meet the District Policy’s minimum threshold.



Manage Debt to Maintain a Stable Tax Rate

\$121.4 Million Net Present Value savings from refinancing and prepayment of bonds over past 10 years

No tax rate increase for \$450M 2017 CIP and \$320M Maintenance Tax Notes

No tax rate increase in over a decade

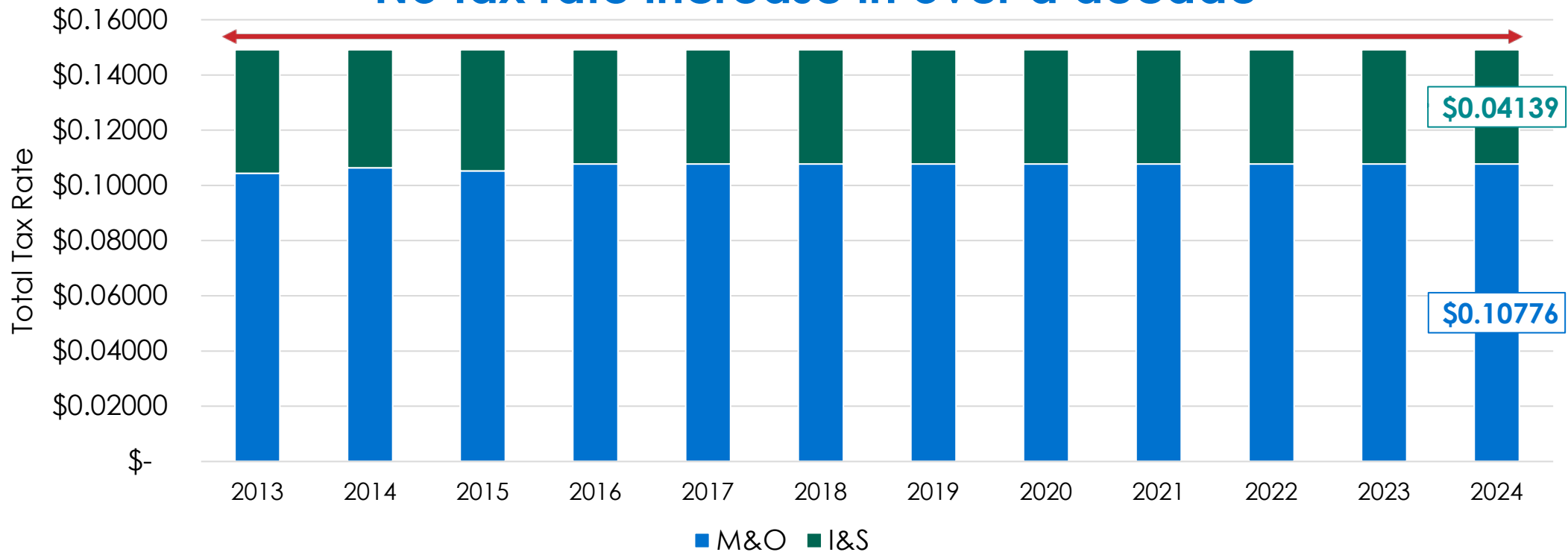

Managing Debt Capacity & Stable Tax Rate

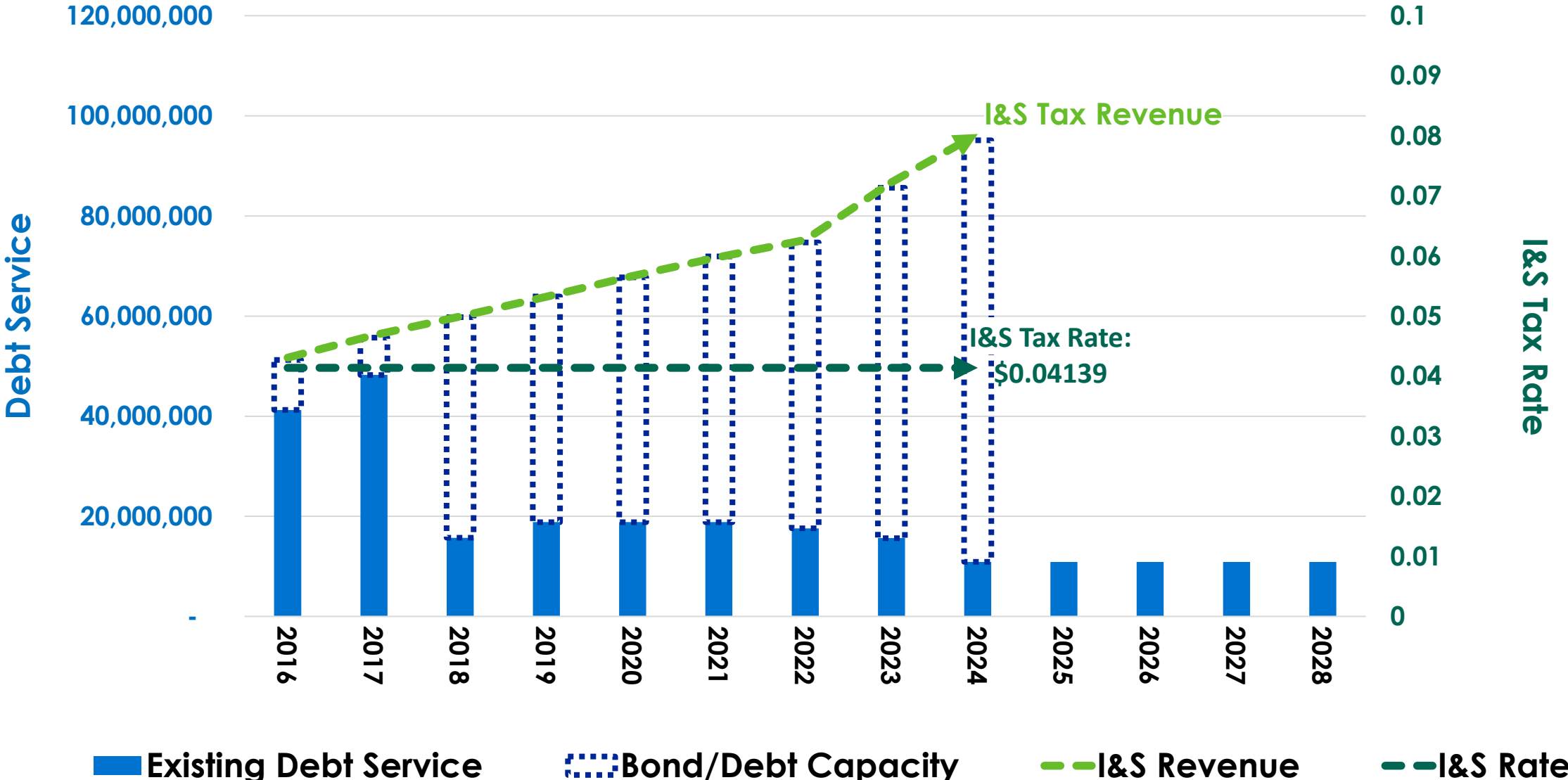

Manage Debt to Maintain a Stable Tax Rate

No tax rate increase expected for new CIP

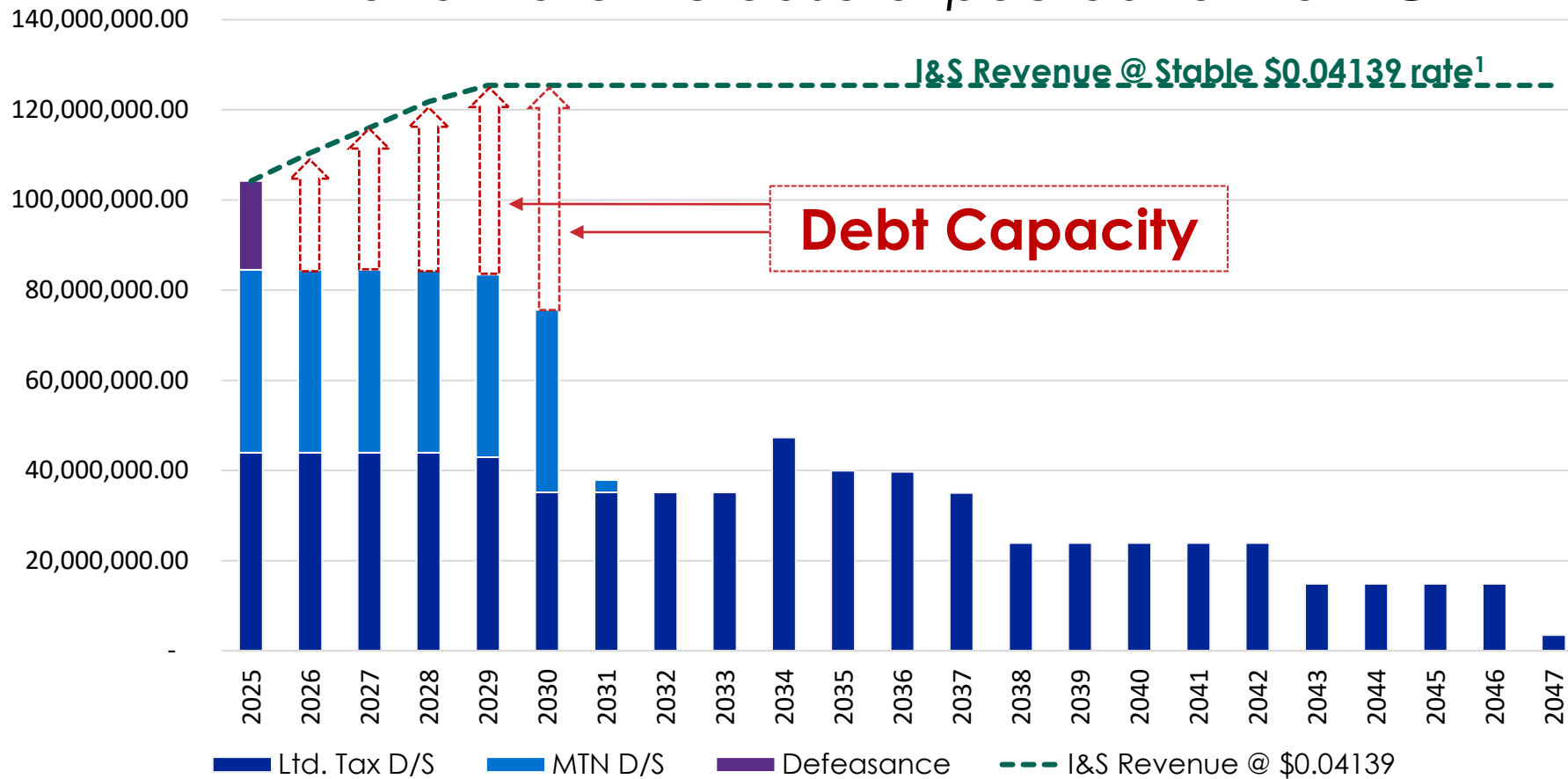

¹ Assumes TAV growth will be 7.5% for FY25, 6% for FY26, 5% for FY27-28, 3% for FY29, and 0% thereafter.

Maintaining Our AAA/Aaa Bond Ratings Through Management of Leveraged Debt

Numerous indicators are used by Moody's and S&P – 2 key ratios related to level of leverage and repayment ability:

- ❖ *Is the District's total debt service + pension contribution + OPEB expense lower than 20% of budget?*
 - ✓ **Yes –The District has averaged 12% over the past 4 Fiscal Years and based on future projections will average around 15%.**

- ❖ *Is the District's cash reserves at least 30% of total operating revenues?*
 - ✓ **Yes –The District's cash reserves are over 30% and future projection indicate we will remain above 30%**



Debt Management Policy C.3.1

The Board of Trustees adopted a Debt Management Policy in 2011.

- This is not a required policy, but is considered a “best practice”, and it is viewed favorably by Rating Agencies.
- The Policy is to be reviewed and approved in conjunction with the annual Debt Mgmt. Plan.
- In coordination with the Legal department and the Municipal Advisor, the Finance department makes updates as needed for clarity and/or changes to applicable federal and state laws.

This Policy (the “Policy”) establishes conditions for the use of debt and creates procedures and policies designed to manage the Alamo Community College District’s (the “College District”) obligations within available resources, minimize the debt service and issuance costs, achieve the highest credit ratings, maintain full, complete, and accurate financial disclosure and reporting, and to comply with appropriate and applicable laws of the State of Texas (the “State”) and federal law.

Recommended Policy Changes:

- The changes to the policy contain fixes to formatting errors. There are no substantive changes.

What are the types of bonds we issue?

Ltd Tax Bonds- Construct, furnish/equip, renovate, purchase land

Who authorizes? Voters

Current ratings: AAA/Aaa

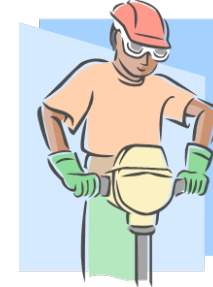

Maintenance Tax Notes- renovate and furnish only

Who authorizes? Board of Trustees

Current ratings: AAA/Aaa



Revenue Bonds- Construct, acquire, renovate, furnish/equip, purchase land

Who authorizes? Board of Trustees

Current ratings: AAA/Aaa



Tax Supported Debt: S&P and Moody's AAA/Aaa

- **Highest AAA/Aaa rating from both S&P Global Ratings and Moody's Investors Services**

Rationale:

- *Deep and diverse economic base*
- *Strong financial position with diverse revenue stream*
- *Substantial operating flexibility in ability to raise tax rate*

ACD is one of only 3 Community College Districts in Texas and 10 Nationally with AAA/Aaa ratings from both S&P and Moody's ⁽¹⁾



How is the debt paid?

Revenue Bonds: Tuition, Investment and Auxiliary Income
Ltd Tax and Maintenance Tax: The “debt” portion of property taxes

Current Property Tax Rate = \$0.14915



\$0.10776 goes to Operations

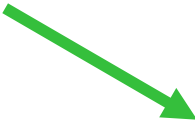

\$0.04139 goes to pay Debt



Status of 2017 Voter Authorization

Voter authorization of \$450 million May 2017

- Final tranche issued December 2022
- Additional \$320 million Maintenance Tax Notes issued for CIP projects

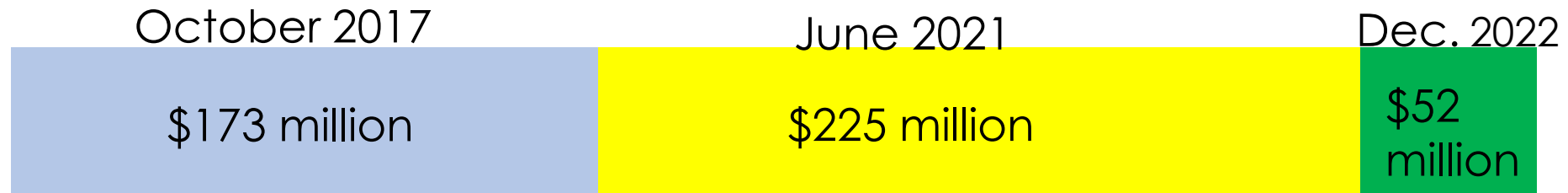

Discussion and Possible Action for the Purchase of a Feasibility Study and Implementation of a Comprehensive Fundraising Campaign

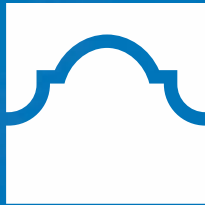

ALAMO
COLLEGES
DISTRICT

Barton T. Simpson
Executive Director
Alamo Colleges Foundation



Action Requested

Approve the awarded contract to Convergent Nonprofit Solutions, LLC providing for the purchase of a Feasibility Study and Implementation of a Comprehensive Fundraising Campaign for an estimated annual revenue amount of \$474,500 as requested by the Chancellor of the Alamo Colleges District.



Thank you.

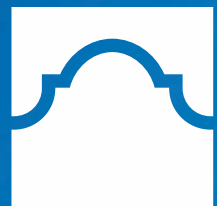

ALAMO
COLLEGES
DISTRICT



Discussion and Possible Action for the Purchase of a Feasibility Study and Implementation of a Comprehensive Fundraising Campaign

Presented to the Board Acting as Committee of the Whole on May 14, 2024 and now presented to the Board for approval on May 21, 2024.

MINUTE ORDER

"The Board of Trustees hereby awards a contract to Convergent Nonprofit Solutions, LLC providing for the purchase of a Feasibility Study and Implementation of a Comprehensive Fundraising Campaign for an estimated annual revenue amount of \$474,500 as requested by the Chancellor of the Alamo Colleges District.

PURPOSE

This contract action provides for the purchase of Feasibility Study and Implementation of a Comprehensive Fundraising Campaign for the Alamo Colleges Foundation. The contract scope of work includes conducting a feasibility study aimed at assessing the viability and potential success of a comprehensive fundraising campaign. The purpose of this study is to provide insights, recommendations, and strategic guidance to inform the Foundation's decision makers regarding the launch of a comprehensive campaign.

BACKGROUND

In March 2024, the formal competitive procurement process was implemented with a solicitation notice, advertising a Request for Proposals (RFP) in the San Antonio Express News, La Prensa, and San Antonio Observer twice over a twenty-eight (28) day period. Additionally, Purchasing and Contract Administration sent notices to eighty-two (82) potential Offerors. The six (6) proposals received by the RFP submission deadline were evaluated by representatives from the Alamo Colleges Foundation in accordance with the terms and conditions, outlined in the RFP. As a result of this effort, the proposal submitted by Convergent Nonprofit Solutions, LLC is recommended for award on a best value basis.

IMPLICATIONS

Financial: \$474,500; 119001–891021–71151

Strategic Plan: Goal I Student Success; and Goal III Performance Excellence

Employee Services: None

Attachments: Price Tabulation

Lisa L. Mazure, MSA, CPA, CGFM
Associate Vice Chancellor, Finance & Fiscal Svc

Barton T. Simpson
Executive Director

Dr. Thomas Cleary
Interim Vice Chancellor for Finance & Administration

Dr. Mike Flores
Chancellor



ALAMO
COLLEGES
DISTRICT



PRICE TABULATION

PURCHASE OF A FEASIBILITY STUDY AND IMPLEMENTATION OF A COMPREHENSIVE FUNDRAISING CAMPAIGN

ITEM NO.	ITEM DESCRIPTION	Brian Lacy & Associates, LLC	Catapult Fundraising, Inc.	CCS Fundraising	Convergent Non-Profit Solutions, LLC	FORVIS, LLP	Ruotolo Associates, Inc.
1	Feasibility Study Development	\$ 45,000	\$ 48,000	\$ 90,000	\$ 39,500	\$ 100,000	No Response
2	Evaluation of Philanthropy Landscape	\$18,500	Included in Item #3	Included in Item #1	Included in Item #1	\$ 40,000	No Response
3	Needs Assessment for key programs and organizational readiness	\$ 19,200	\$ 8,750	Included in Item #1	\$ 15,000	\$ 86,000	No Response
4	Campaign Development with Strategies & Objectives	\$19,200	\$ 44,000	Included in Item #1	\$ 210,000	\$ 36,000	No Response
5	Other		\$ 288,000	\$ 546,000	\$ 210,000	\$ 13,000	No Response
	Total:	\$ 101,900	\$ 448,750	\$ 636,000	\$ 474,500	\$ 275,000	No Response
	Price Ranking	5	1	4	2	3	No Response
	Technical Ranking	5	2	4	1	3	No Response
	Overall Ranking	5	2	4	1	3	No Response

Notes:

1. Normally, reasonableness of price is established through adequate competition, but may also be separately assessed through price analysis techniques. For this RFP, a total price was calculated for each proposal, and then all total prices were averaged. The proposal prices were then individually compared to the average price and ranked in accordance with the CSP Purchase Price Evaluation Criteria.
2. The proposal submitted by Ruotolo was not evaluated because they did not submit pricing in the format requested in the RFP solicitation.



PRICE TABULATION

PURCHASE OF A FEASIBILITY STUDY AND IMPLEMENTATION OF A COMPREHENSIVE FUNDRAISING CAMPAIGN

Criteria	Weighting
Purchase Price	30
Reputation of the Vendor and of the Vendor's Goods or Services: <ul style="list-style-type: none"> - Any litigation against the firm - Organizational chart - References - Lost Accounts 	20
Quality of Vendor's Goods and Services: <ul style="list-style-type: none"> - Awards or Recognition Received. - Profile outlining the history, philosophy, and target market of the firm. - List of policies and procedures followed to maintain service excellence. - Efforts the firm makes to keep staff informed of changes in the industry. 	10
Extent to Which the Goods or Services Meet the District's Needs: <ul style="list-style-type: none"> - Background and experience in providing services. - Meet requirements in the Statement of Work 	35
Total Long-Term Cost to the District to Acquire the Vendor's Goods or Services: <ul style="list-style-type: none"> - Thorough examination of the total long-term cost associated with acquiring the vendor's services 	5
Total:	100

Contract for the Purchase of a Feasibility Study and Implementation of a Comprehensive Fundraising Campaign

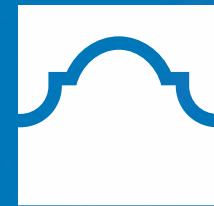

ALAMO
COLLEGES
DISTRICT

BARTON T. SIMPSON
Executive Director
Alamo Colleges Foundation



Board Policies in Support of Charges

- C.1.3 (Policy) Appropriations and Revenue Sources
- Grants and Donations: The authority to accept and receive donations and grants from public or private sources on behalf of any college of the College District, or the College District as a whole shall be vested solely with the Board, and all bequests of property for the benefit of the College District shall vest in the Board, except to the extent that the Alamo Colleges Foundation serves as the official fund-raising and endowment arm of the College District for all donations from private sources.

Charges to the Chancellor

- College Access and Completion
- Institutional Excellence and Continuous Improvement
- Strategic Communication and Marketing



ABOUT US AND THE ROLE OF ADVANCEMENT

The Alamo Colleges Foundation, established in 1984, serves as the philanthropic arm of the Alamo Colleges District. Its mission is to provide financial support and resources to enhance the educational opportunities and success of students attending the Alamo Colleges, thereby empowering individuals to achieve their academic and career goals. Through scholarships, grants, and partnerships with donors and community organizations, the Foundation strives to remove financial barriers and foster student success within the Alamo Colleges District.



Some of our Initiatives:

- AlamoPROMISE
- Student Scholarships
- Event Sponsorships
- Program Support
- Alumni Giving
- Employee Giving
- Capital Campaign Support
- Endowment Growth

FOUNDATION SCHOLARSHIP IMPACT

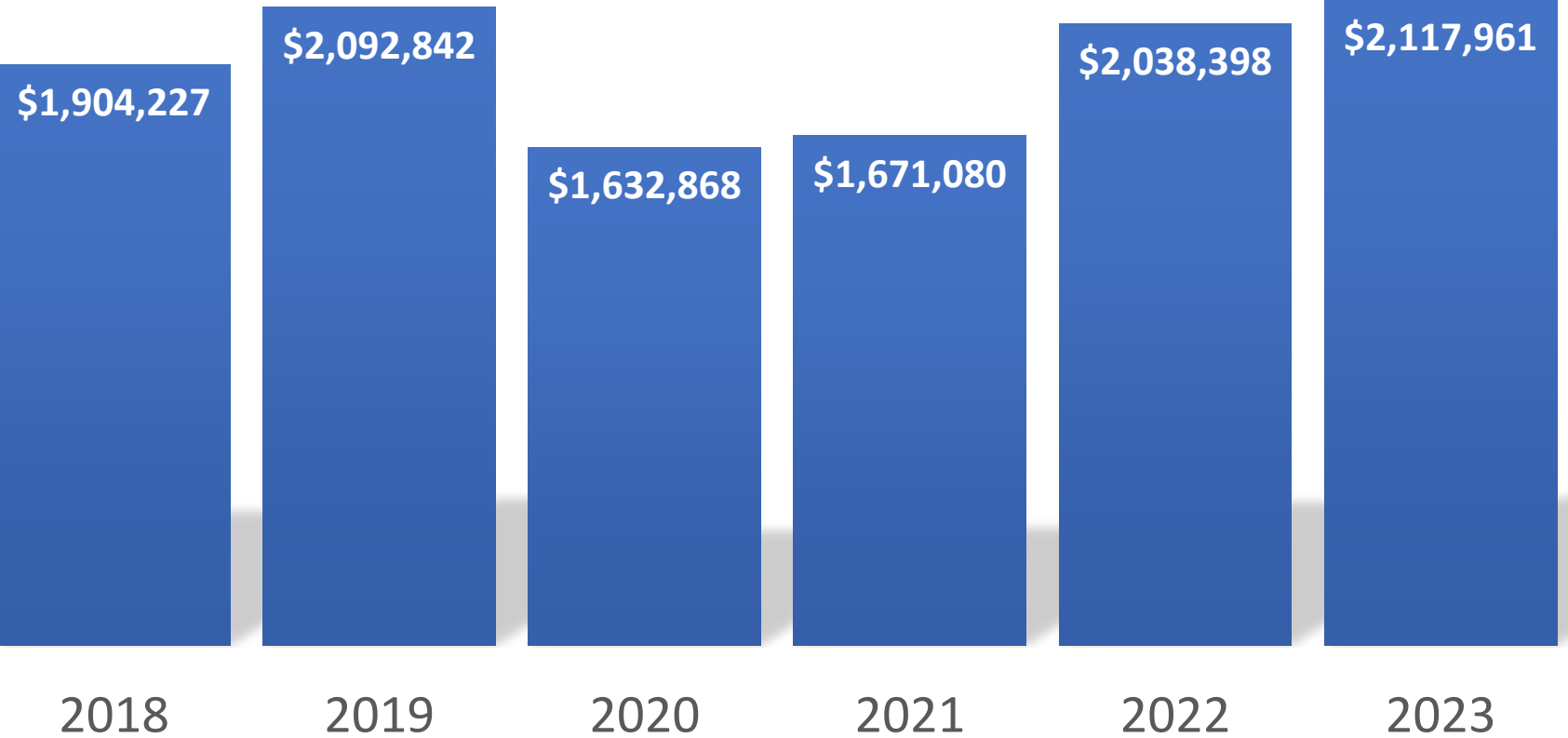

Since the Inception of the Foundation, almost **\$37,000,000** in Foundation funds have been awarded in **Scholarships.**



Net Assets Trend Data 2013 – 2024*

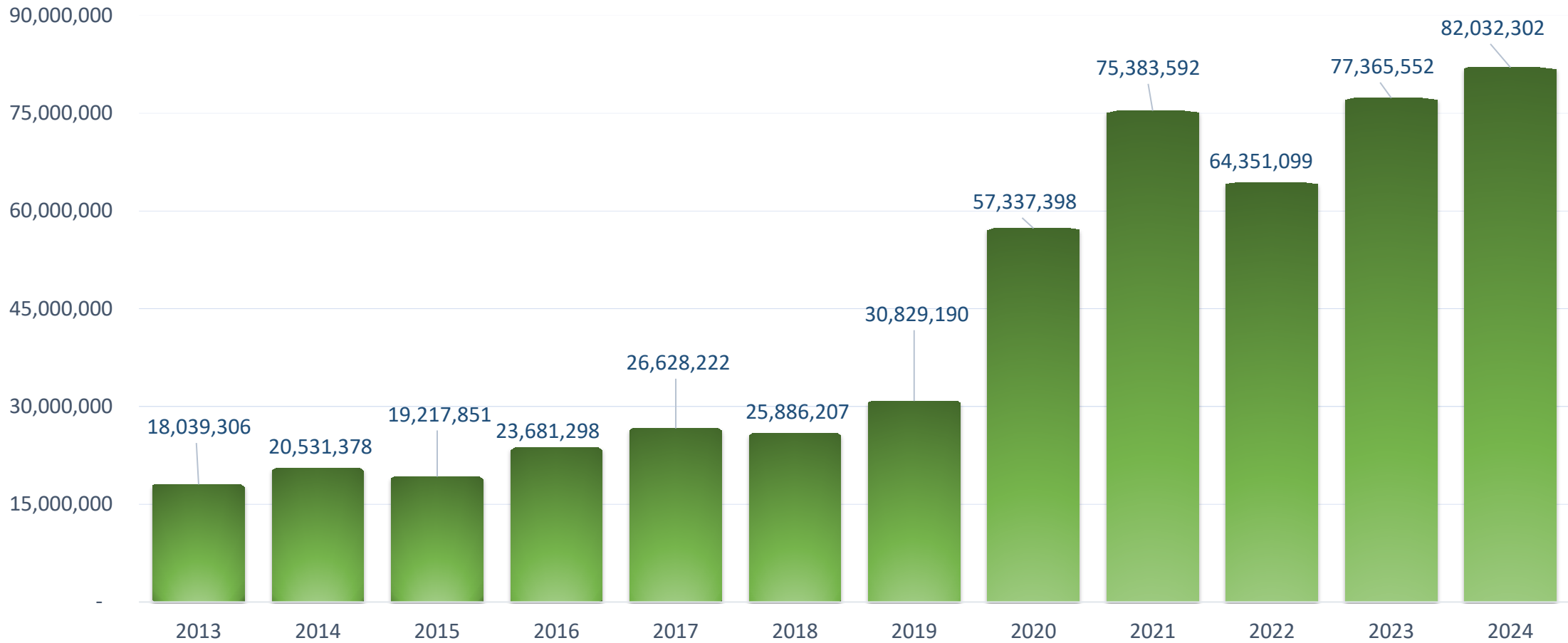

* As of 3/31/2024

↓
\$20M
 PAC gift

↓
\$15M
 SAC gift



ALAMO
 COLLEGES
 DISTRICT



Purpose

- District Institutional Advancement Office is seeking approval to award a contract for a feasibility study aimed at assessing the viability and potential success of a comprehensive fundraising campaign. The purpose of this study is to provide insights, recommendations, and strategic guidance to inform the District's decision-makers regarding the launch of a comprehensive campaign.
- Proposals were requested from multiple firms via Request for Proposal.
- Five firms submitted a complete proposal. The responding firms were evaluated with a best-value source selection approach and Convergent Nonprofit Solutions, LLC was selected.

Total Project Budget: \$474,500

Recommended Contract Action: Award a contract for Feasibility Study and Implementation of a Comprehensive Fundraising Campaign

Type of Contract Action: This minute order awards a contract to Convergent Nonprofit Solutions, LLC.

Contract Term: This contract will begin upon award and terminate upon completion of services.

SMWVBE: N

Local: N

Funding: Institutional Funds - \$474,500



Thank you.

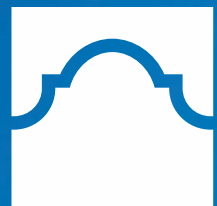

ALAMO
COLLEGES
DISTRICT



Appendix - Background

- A notice soliciting Request for Proposals (RFP) was advertised in the San Antonio Express News, La Prensa, and San Antonio Observer twice over a 28-day period. Additionally, Purchasing and Contract Administration sent notices to 82 potential Offerors.
- The six (6) proposals received by the RFP deadline were evaluated by representatives from the District Institutional Advancement Office considering the specifications and requirements of the CSP.
- As a result of this effort, the proposal submitted by Convergent Nonprofit, LLC is recommended for award on a best value basis.

PRICE TABULATION

PURCHASE OF A FEASIBILITY STUDY AND IMPLEMENTATION OF A COMPREHENSIVE FUNDRAISING CAMPAIGN

ITEM NO.	ITEM DESCRIPTION	Brian Lacy & Associates, LLC	Catapult Fundraising, Inc.	CCS Fundraising	Convergent Non-Profit Solutions, LLC	FORVIS, LLP	Ruotolo Associates, Inc.
1	Feasibility Study Development	\$ 45,000	\$ 48,000	\$ 90,000	\$ 39,500	\$ 100,000	No Response
2	Evaluation of Philanthropy Landscape	\$18,500	Included in Item #3	Included in Item #1	Included in Item #1	\$ 40,000	No Response
3	Needs Assessment for key programs and organizational readiness	\$ 19,200	\$ 8,750	Included in Item #1	\$ 15,000	\$ 86,000	No Response
4	Campaign Development with Strategies & Objectives	\$19,200	\$ 44,000	Included in Item #1	\$ 210,000	\$ 36,000	No Response
5	Other		\$ 288,000	\$ 546,000	\$ 210,000	\$ 13,000	No Response
	Total:	\$ 101,900	\$ 448,750	\$ 636,000	\$ 474,500	\$ 275,000	No Response
	Price Ranking	5	1	4	2	3	No Response
	Technical Ranking	5	2	4	1	3	No Response
	Overall Ranking	5	2	4	1	3	No Response

Notes:

- Normally, reasonableness of price is established through adequate competition, but may also be separately assessed through price analysis techniques. For this RFP, a total price was calculated for each proposal, and then all total prices were averaged. The proposal prices were then individually compared to the average price and ranked in accordance with the CSP Purchase Price Evaluation Criteria.
- The proposal submitted by Ruotolo was not evaluated because they did not submit pricing in the format requested in the RFP solicitation.



Discussion and Possible Action on Purchasing Equipment for St. Philip's College Cybersecurity Curriculum

Dr. Raymond Chacon

Department Chair, St. Philip's College

Dr. Adena Loston

President, St. Philip's College

Lisa L. Mazure MSA, CPA

Associate Vice Chancellor for Finance & Fiscal Services

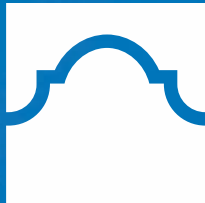

ALAMO
COLLEGES
DISTRICT



Action Requested

Approve the awarded contract to Redknight LLC. Providing for the purchase of additional Cyber Security Range training Equipment in the amount of \$540,697.05 as requested by the Office of the President at St. Philip's College.



Thank you.

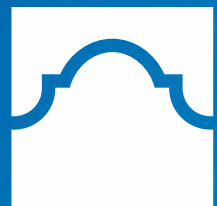

ALAMO
COLLEGES
DISTRICT



Discussion and Possible Action of Purchase Equipment to Expand the Bachelor of Applied Technology (BAT) Cybersecurity Curriculum for the Alamo Colleges District – St. Philip’s College (SPC)

Presented to the Board Acting as Committee of the Whole on May 14, 2024 and now presented to the Board for approval on May 21, 2024.

MINUTE ORDER

"The Board of Trustees hereby awards a contract to RedKnight LLC. providing for the purchase of additional Cyber Security Range Training Equipment in the amount of \$540,697.05 as requested by the Office of the President at St. Philip’s College."

PURPOSE

This contract action provides for the further expansion of the cyber security range training equipment from RedKnight LLC. that increases the training capacity of the current Cyber Range. The Cyber Security Range allows students to build actual corporate networks of various sizes and complexity that will then be actively exploited. Students in this environment will be able to test, train, and exercise cybersecurity skills across the entire gambit of the profession and not just the monitoring skills commonly employed by a help desk or a network watch center. All students and faculty from the Information Technology Network Administration and Cybersecurity Specialist programs will benefit and will use these products in remote learning and lab functionality.

BACKGROUND

On April 20, 2021, the Board of Trustees approved the addition of the Cyber Range scope of work to be funded with Coronavirus Response and Relief Supplemental Appropriations Act, CRRSAA funds.

In August 2021, the Board approved amending the Guaranteed Maximum Price by \$1,615,722 to \$12,422,223 under the contract with Construction Manager-at-Risk Skanska USA Building, Inc. for the construction cost to add a Cyber Range to the Alamo Colleges District – St. Philip’s College (SPC) Bowden Replacement Building Capital Improvement Project (CIP). At that time, the total project budget was presented of \$16,638,120 which included estimated costs of related furniture, fixtures and equipment to be purchased directly from suppliers but installation managed by Skanska.

In October 2021 the Board authorized the purchase of equipment and materials from RedKnight, LLC to outfit the Cyber Range training facility.

In December 2023 the Board authorized the purchase of training curriculum and equipment in the amount of \$4,500,000 from RedKnight, LLC to expand the Cyber Range.

This recommendation seeks to award a contract to RedKnight, LLC providing for the purchase of additional Cyber Security Range Training Curriculum and Equipment in the amount of \$540,697.05 on a sole source basis.

IMPLICATIONS

Financial: \$540,697.05

Funding Source: St. Philip's College Capital Funds

Strategic Plan: Goal I – Student Success; Goal III Performance Excellence Employee

Services: None

ATTACHMENT: DrCv2-Cyber Security Range Presentation – SPC – PP

Adena Williams Loston 5/9/2024

Dr. Adena Williams Loston
President, St. Philip's College

Dr. Thomas Cleary
Interim Vice Chancellor for Finance
and Administration

Dr. Mike Flores
Chancellor

Overview of Purchase Contract Award – Purchase Equipment to Expand The Bachelor of Applied Technology (BAT) Cybersecurity Curriculum for the Alamo Colleges District – St. Philip’s College (SPC)

Dr. Raymond Chacon
Department Chair, St. Philip’s College

Dr. Adena Loston
President, St. Philip’s College

Lisa L. Mazure MSA, CPA
Associate Vice Chancellor for Finance & Fiscal Services

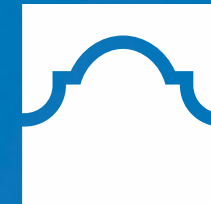

ALAMO
COLLEGES
DISTRICT



Board Policies in Support of Charges

- *C.1.5 (Policy) Purchasing and Acquisitions*
- *F.6.1 (Policy) Student Success*

Charges to the Chancellor

- *Student Equity and Success*
- *Credentials of Value*



Award a Contract - Purchase Equipment to Expand the Bachelor of Applied Technology (BAT) Cybersecurity Curriculum for the Alamo Colleges District – St. Philip's College (SPC)

- Augment equipment in the Cybersecurity Innovation Center (CIC) to expand the Cyber Range capabilities
- Broaden the scope and depth of the curriculum
- Capability for hosting IT competitions and competing nationally with other universities in cyber warfare
- Create various academic cloud-based environments to test, train, and apply a more robust cybersecurity skill set across various large-scale networks
- Capability for all students and faculty to access remotely via *SPC Cloud on the Ground* architecture

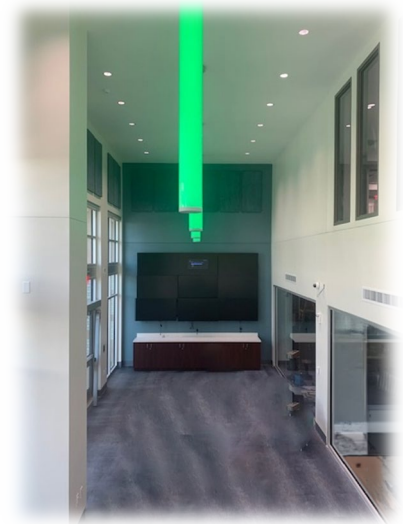

Recommended Contract Action: Award a contract for the purchase of Equipment to Expand the Bachelor of Applied Technology (BAT) Cybersecurity Curriculum.

- The Cyber Range will continue to allow for students innovation, sharpen their skill set and apply more advanced mitigation strategies in one-of-a-kind environments.
- The unique characteristics of the Cyber Range will continue to make St. Philip's College stand out as the leader in cyber security training in San Antonio and the State of Texas.



Recommended Contract Action: Award a contract to purchase equipment to expand the Bachelor of Applied Technology (BAT) Cybersecurity Curriculum for the Alamo Colleges District – St. Philip’s

Type of Contract Action: This minute order awards a contract to RedKnight, LLC.

Contract Term: This is a one-time purchase.

SMWVBE: Y (Veteran Owned)

Local: Y (RedKnight, LLC)

Funding: \$540,697.05; HBCU HEERF grant



Thank you.



ALAMO
COLLEGES
DISTRICT



Appendix - Background

- On April 20, 2021, the Board of Trustees approved the addition of the Cyber Range scope of work to be funded with Coronavirus Response and Relief Supplemental Appropriations Act, CRRSAA funds.
- In August 2021, the Board approved amending the Guaranteed Maximum Price by \$1,615,722 to \$12,422,223 under the contract with Construction Manager-at-Risk Skanska USA Building, Inc. for the construction cost to add a Cyber Range to the Alamo Colleges District – St. Philip’s College (SPC) Bowden Replacement Building Capital Improvement Project (CIP). At that time, the total project budget was \$16,638,120 which included estimated costs of related furniture, fixtures and equipment to be purchased directly from suppliers but installation managed by Skanska.
- In October 2021 the Board authorized the purchase of equipment and materials to outfit the Cyber Range training facility.
- In December 2023 the Board authorized the purchase of training curriculum and equipment in the amount of \$4,500,000 from RedKnight, LLC to expand the Cyber Range.
- This recommendation seeks to award a contract to RedKnight, LLC providing for the purchase of additional Cyber Security Range Training Curriculum and Equipment in the amount of \$540,697.05 on a sole source basis.



Discussion and Possible Action on the Northeast Lakeview College AAS in Nursing

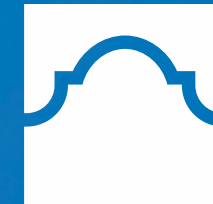

ALAMO
COLLEGES
DISTRICT

Crystal Saulsberry DNP, MSN, RN
Executive Director of Nursing, NLC



Action Requested

Approve the submission to the Texas Higher Education Coordinating Board of a new workforce education program of study for an Associate of Applied Science Degree in Nursing for Northeast Lakeview College.



Thank you.

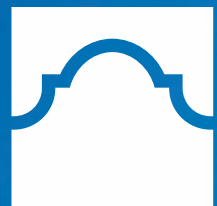

ALAMO
COLLEGES
DISTRICT



Discussion and Possible Action on the Approval of Northeast Lakeview College Associate of Applied Science Degree in Nursing

Presented to the Board Acting as a Committee of the Whole on ___ and now presented to the Board for approval on __.

MINUTE ORDER

"The Alamo Colleges Board of Trustees hereby approves the submission to the Texas Higher Education Coordinating Board of a new workforce education program of study for an Associate of Applied Science Degree in Nursing for Northeast Lakeview College."

PURPOSE

The purpose of this Minute Order is to authorize the President of Northeast Lakeview College or her designee to submit to the Texas Higher Education Coordinating Boards a program of studies of 60 semester credit hours for the college to deliver the Associate of Applied Science Degree in Nursing.

BACKGROUND

A nurse is a person required to be licensed under Texas Occupations Code chapter 301 to engage in professional or vocational nursing. Nursing is the diagnosis and treatment of human responses and advocacy in the care of individuals, families, groups, communities, and populations in recognition of the connection of all humanity. Nursing integrates the art and science of caring and focuses on the protection, promotion, and optimization of health and human functioning; prevention of illness and injury; facilitation of healing; and alleviation of suffering through compassionate presence.

Registered Nurse positions have a projected growth of 18.3 % during 2020-30 within the Alamo region. The entry level wage is \$38.89 an hour. Enrollment projections are 30 students for the first three years progressing to 100 students annually beginning year four.

IMPLICATIONS

Financial: **Five Year Projection:** 5- year positive net income of \$136,817.50
Strategic Plan: Strategic Objective I: Student Success
Human Resources: Faculty, and Adjunct Faculty
Attachments: Exhibit 1, Business Plan Summary
Exhibit 2, Program Curriculum - Degree Plan
Exhibit 3, Pre-application

Dr. Veronica Garcia
President, Northeast Lakeview College

Dr. George Railey, Jr.
Vice Chancellor for Academic Success

Dr. Michael Flores
Chancellor



Registered Nurse Associate of Applied Science

Crystal Saulsberry DNP, MSN, RN
Executive Director of Nursing, NLC

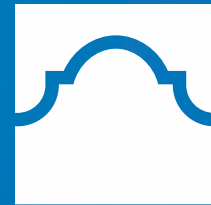

ALAMO
COLLEGES
DISTRICT



Board Policies in Support of Charges

- E.1.4: Core Curriculum and Degrees
- E.1.6: Program and Course Offerings

Charges to the Chancellor

- Address Workforce Needs of the City/County and Service Area

Registered Nurse careers project 18.3 % growth for the Alamo Region by 2030

Entry level high-demand careers include:

- Registered Nurses
- Licensed Practical and Vocational Nurses
- Nurse Practitioners

Projected Employment in 2030: Alamo Region – 26,337 jobs and Texas – 258,715 jobs

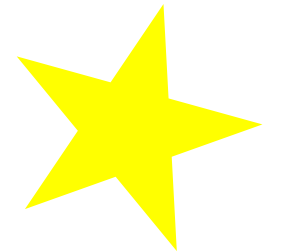

Entry-level positions for Registered Nurses are on the Workforce Solutions Alamo Demand Occupations list: job demand is projected to **increase by 18.3 %** in the Alamo Region between 2020 and 2030

*Texas Labor Market <https://texaslmi.com/Home/PopularDownloads>

Alamo Colleges District Nursing Programs

Registered Nurse to Bachelor of Science in Nursing (RN-BSN)

- SAC

Associate of Applied Science in Nursing (AAS)

- SAC
- SPC
- PAC

Licensed Vocational Nurse (LVN)

- SPC

LVN to RN AAS/Military to RN AAS

- SAC
- SPC



Registered Nurse, A.A.S.

- The program will be offered in a 16-week format and the full AAS will be designed for completion within 2 years
- Expect to add 30 completers to the workforce the first three academic years. Expanding to 100 completers each academic year starting year 4.
- The Associate Degree in Nursing program will be scheduled into available classrooms and lab spaces in the Paluxy building

*Texas Board of Nursing [Rule 214.4.]The number of students to be enrolled while the program is on initial approval is determined by the Board.

Registered Nurse, A.A.S. Tuition

Alamo Colleges affordable tuition rates

- Texas In-District Per Semester Credit \$109
- Special Program Tuition \$165.00 Per Semester Credit (*Nursing courses)

* Tuition and fees are subject to change by the Texas State Legislature and the Alamo Colleges District Board of Trustees.



Registered Nurse [1 – 5 semesters]

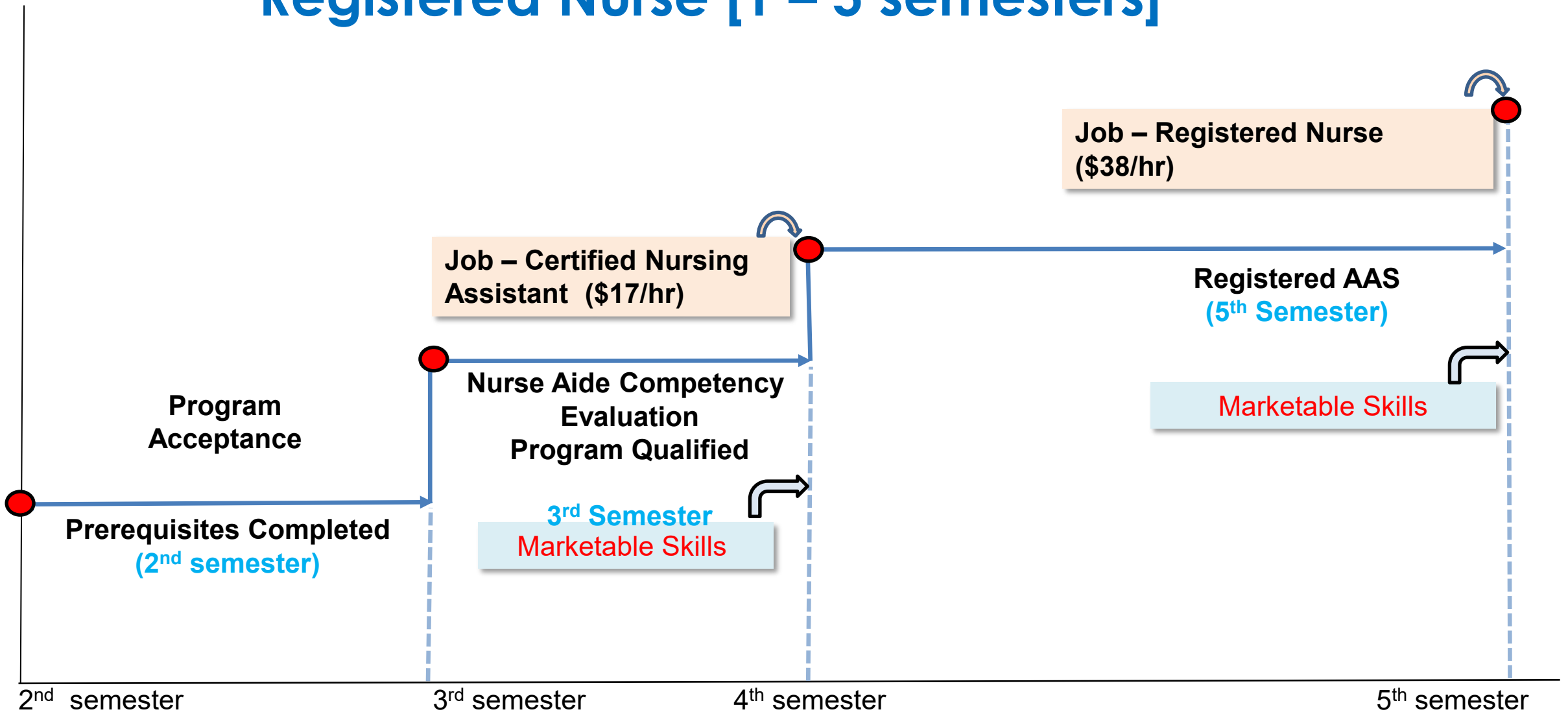

The Nursing Program Industry Advisory Committee

- Crissy Kidd Clinical Educator, Christus Santa Rosa New Braunfels
- Glenn Dennis Chief Nursing Officer, Methodist Northeast
- Dr. Crissy Womble Assistant VP Academic Partnerships, Methodist San Antonio
- April Thompson, Director of Academic Partnerships, Methodist San Antonio
- Dr. Sonya Hardin, Dean of Nursing UTHSC San Antonio
- Lorna Thomas, Market Staff Development Educator, Baptist San Antonio
- Dr. Charles Reed VP Associate Chief Nursing Officer, University Health San Antonio

Program Development - Expenses and Revenue

- **5-Year Costs/Expenses:**
 - **Equipment ***
 - **Faculty/Adjuncts/Staff: \$2,336,836.51**
 - **Other Costs: \$99,000**
 - **Indirect Cost : \$7,560**

5 -Year Net Income/Loss

- **Total Cost/Expenses: \$2,443,396.50**
- **Total Revenue: \$2,580,214**

*The program will use existing equipment.



Program Development - Expenses and Revenue Cont.

5-Year Revenue Generated

- Regular Tuition: \$1,246,524
- Student Outcome Funding: \$ 427,840
- Special Program Tuition: \$905,850

5 -Year Net Income/Loss

- Total Cost/Expenses: \$2,443,396.50
- Total Revenue: \$2,580,214

Net 5-Year Income: **\$136,817.50**



Action Requested

Approve submission to the Texas Higher Education Coordinating Board of a new workforce education program of study for an Associate of Applied Science Degree in Nursing.



Thank you.

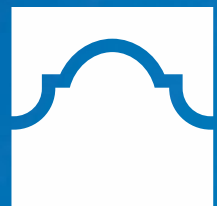

ALAMO
COLLEGES
DISTRICT



FROM: Crystal Saulsberry Executive Director of Nursing

Subject: Business Plan – New Health Sciences Program: Associate Degree in Nursing

TO: SLT

1. **Program Name:** Associate Degree in Nursing, A.A.S.

2. **Program Purpose:** The Associate of Applied Science will prepare students with the knowledge and skills to provide entry level nursing care as defined by the Texas Nursing Practice Act and enforced by the Texas Board of Nursing. The program will address workforce needs and the existing and emerging health care demands of the community. Upon completion of the program students will be eligible to sit for the National Council Licensure Examination (NCLEX).

3. **Program Outcomes:**

1. Use clinical reasoning and knowledge based on the nursing program of study, evidenced-based practice outcomes, and research-based policies and procedures as the basis for decision-making and comprehensive, safe patient care.
2. Demonstrates skills in using patient care technologies and information systems that support safe nursing practice.
3. Promotes safety and quality improvement as an advocate and manager of nursing care.
4. Coordinate, collaborate and communicate with diverse patients, families, and the interdisciplinary health care team to plan, deliver, and evaluate care.
5. Adheres to standards of practice within legal, ethical, and regulatory frameworks of the professional nurse.
6. Demonstrates knowledge of delegation, management, and leadership skills.
7. Demonstrate behavior that reflects the values and ethics of the nursing profession.

4. **Five-Year Costs/Investment:**

- Equipment: Existing
 - Faculty: \$2,336,836.51
 - Facility Impacts: Existing
 - Other Costs: \$99,000
- Total Five-Year Expenses: \$2,435,836.50**

5. **Five-Year Revenue Generated:**

- Projected Enrollment:
 - 290 students over five years
 - Students completing the program over a five-year period: 232 students (80%)
- Projected Accumulated Credit Hours: 9,306.0
- Regular Tuition: \$1,246,524
- Student Outcome funding: \$427,840
- Special Program Tuition: \$905,850
- Total Five-Year Revenue: \$2,580,214**

6. **Job/Employer Demand:** Alamo registered nurses have a projected employment of over 26,337 by 2030, an increase of over 18.3 percent.

Occupation Title	Annual Average Employment 2020	Annual Average Employment 2030	Number Change 2020-2030	Percent Growth 2020-2030
Registered Nurses (Alamo)	22,258	26,337	4,079	18.3%
Registered Nurses (Texas)	220,984	258,715	37,731	17.1%

*Texas Labor Market <https://texaslmi.com/Home/PopularDownloads>

7. **Five-Year Projected Job Placement:** 30 per year

8. **Projected Program Milestones: (Completers of cohort of 30 enrolled)**

- Year 1 cohort: 30 new Declared Majors
- Year 2 cohort: 30 new Declared Majors
- Year 3 cohort: 30 new Declared Majors; Year 1 cohort completers – 24 (80%); 100% job placement
- Year 4 cohort: 100 new Declared Majors; Year 2 cohort completers – 24 (80%); 100% job placement
- Year 5 cohort: 100 new Declared Majors; Year 3 cohort completers – 24 (80%); 100% job placement

9. **Other Pertinent Information:**

- Proposing AAS (60 hrs.)

ALAMO COMMUNITY COLLEGES
NEW PROGRAM DEVELOPMENT
PRE-APPLICATION CHECKLIST
for Northeast Lakeview College (NLC)

Program Title: Associate Degree in Nursing, A.A.S.

CIP: 51.3801

A. Program Objectives:

The Associate of Applied Science will prepare students with the knowledge and skills to provide entry level nursing care as defined by the Texas Nursing Practice Act and enforced by the Texas Board of Nursing. The program will address workforce needs and the existing and emerging health care demands of the community. Upon completion of the program students will be eligible to sit for the National Council Licensure Examination (NCLEX).

Program Student Learning Outcomes:

1. Use clinical reasoning and knowledge based on the nursing program of study, evidenced-based practice outcomes, and research-based policies and procedures as the basis for decision-making and comprehensive, safe patient care.
2. Demonstrates skills in using patient care technologies and information systems that support safe nursing practice.
3. Promotes safety and quality improvement as an advocate and manager of nursing care.
4. Coordinate, collaborate and communicate with diverse patients, families, and the interdisciplinary health care team to plan, deliver, and evaluate care.
5. Adheres to standards of practice within legal, ethical, and regulatory frameworks of the professional nurse.
6. Demonstrates knowledge of delegation, management, and leadership skills.
7. Demonstrate behavior that reflects the values and ethics of the nursing profession.

B. Existing program information for initiating college:

San Antonio, Palo Alto, and St. Phillips College have existing Nursing Generic AAS programs.

C. Occupational Need:

1. Is the number of employment opportunities in this job growing? Yes X No

Supporting Evidence: Employment of registered nurses is projected to grow 6 percent from 2022 to 2032, faster than the average for all occupations. (Bureau of Labor Statistics, U.S. Department of Labor, *Occupational Outlook Handbook*, Registered Nurses, at <https://www.bls.gov/ooh/healthcare/registered-nurses.htm>)

2. Will the need for trained personnel be sustained over the next five years? Yes X No

Supporting Evidence: About 193,100 openings for registered nurses are projected each year, on average, over the decade.

(Bureau of Labor Statistics, U.S. Department of Labor, *Occupational Outlook Handbook*, Registered Nurses, at <https://www.bls.gov/ooh/healthcare/registered-nurses.htm>)

3. What information is available from local and/or state labor market sources concerning this occupational title?

Between 2022 and 2036, statewide supply of RNs is projected to not meet demand. Based on these projections, 15.6% of the projected demand for RNs in 2036 will not be met.

Nursing supply and demand projections. | Texas DSHS.
<https://www.dshs.texas.gov/texas-center-nursing-workforce-studies/nursing-supply-demand-projections>

Registered nurses have a projected employment of over 219,000 by 2030, an increase of over 17 percent.

Report on Texas growth occupations - 2023. Texas Workforce Commission.
<https://www.twc.texas.gov/sites/default/files/ogc/mtg23/commission-meeting-material-121923-item12-texas-growth-occupations-2023-twc.pdf>

- a. Is this occupational title on the Demand Occupations List? Yes X No
- b. Indicate the entry-level salary for this occupational title \$43.37
(Mean/Texas, \$38.89 (Mean/Alamo)
Wages - Texas LMI. (n.d.). <https://texaslmi.com/LMIbyCategory/Wages>



D. Assessment of Employer Support – ADVISORY BOARD COMMITTEE INPUT

1. How many companies will show preference to hiring completers of this program? 4
2. How many companies will provide employees incentive to complete this training by providing:
 - a. Higher pay? Yes, with experience
 - b. Opportunity for promotion? Yes
 - c. Tuition or other financial support? Yes

E. Assessment of Training Capacity

1. Geographic implications for program location
 - a. On a map, indicate the companies that would support and/or be served by the development of a new program for this occupational title.

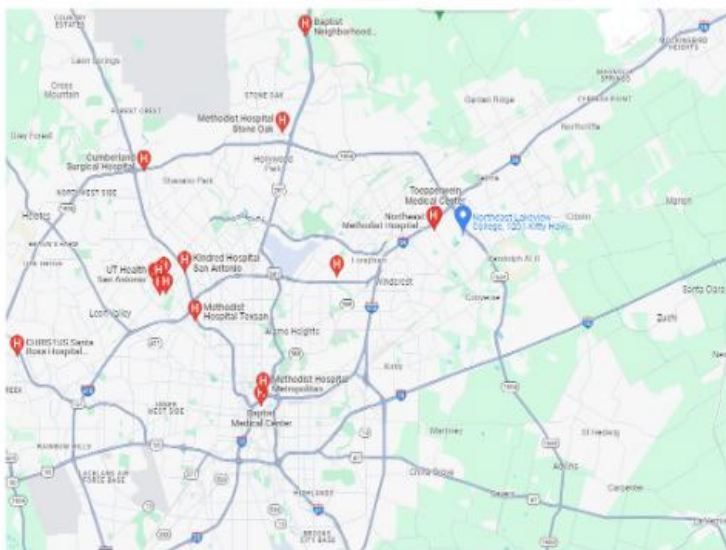

2. Suitability of campus resources to support this program

a. Does the college currently have the following resources to begin this program?

- | | | |
|---------------------------|--------------|-------------|
| • Equipment | Yes <u>X</u> | No |
| • Facilities | Yes <u>X</u> | No |
| • Faculty | Yes <u>X</u> | No <u>X</u> |
| • Instructional resources | Yes | No <u>X</u> |
| • First-year budget | Yes <u>X</u> | No |

If “No” to any of the above areas, describe the resource commitment needed.

- MSN prepared nursing faculty are needed to support the program.

b. Should this program be provided by more than one college? Yes X No

F. College Commitment to Develop a New Program

Based on the above information and the attachments, the administration of this college is committed to the full development, implementation, and sustained operation of the program until the demand has been fully satisfied.

Signature _____

Date _____

Title _____



New AAS or Certificate Degree Plan Form

Degree Plan Title: Associate of Applied Science in Nursing				College: NLC
Major Code: <i>(assigned by CSI)</i>				Effective Term: Fall 2025
				ApplyTexas: <i>(assigned by CSI)</i>

Degree Plan Description:
The Associate Degree in Nursing (ADN) is a 2-year degree that provides students with the foundational knowledge, hands-on experience, and clinical skills to secure an entry level position as a registered nurse. Upon completion of the program students will be eligible to sit for the National Council Licensure Examination (NCLEX-RN) which must be passed to be licensed by the state.

Degree CIP: 51.3801	Is this an addition of an award to an existing CIP?	No
Dept to assign program to: Academic Affairs		

	Lecture Hours	Lab Hours	External Hours (Practicum, Internsh)	Contact Hours	Credit Hours
Semester I (Fall)					
BIOL 2401 - Anatomy & Physiology I	3	3	0	96	4
PSYC 2301 General Psychology	3	0	0	48	3
BIOL 2402 - Anatomy & Physiology II	3	3	0	96	4
BIOL 2420 Microbiology for Nursing and Allied Health or BIOL Microbiology for Science Majors	3	4	0	96	4
Semester II (Spring)					
RNSG 1125 - Professional Nursing Concepts I	1	0	0	16	1
RNSG 1128 - Introduction to Health Care Concepts	1	0	0	16	1
RNSG 1161 Clinical: RN Health Care Concepts I	0	0	4	64	1
RNSG 1216 Professional Nursing Competencies	0	8	0	128	2
RNSG 1430 Health Care Concepts I	3	4	0	112	4
ENGL 1301 Composition I	3	0	0	48	3
Semester III (Fall)					
RNSG 1533 - Health Care Concepts II	4	4	0	128	5
RNSG 1126 - Professional Nursing Concepts II	1	0	0	16	1
RNSG 2362 Clinical: RN Health Care Concepts II	0	0	12	192	3
PSYC 2314 Lifespan Growth and Development	3	0	0	48	3
Semester IV (Spring)					
RNSG 1137 - Professional Nursing Concepts III	1	0	0	16	1
RNSG 1538 - Health Care Concepts III	4	4	0	128	5
RNSG 2363 Clinical: RN Health Care Concepts III	0	0	12	192	3
PHIL 2306 Introduction to Ethics	3	0	0	48	3
Semester V (Fall)					
RNSG 2138 - Professional Nursing Concepts IV	1	0	0	32	1
RNSG 2539 - Health Care Concepts IV	4	4	0	128	5
RNSG 2360 Clinical: RN Health Care Concepts IV	0	0	12	192	3
Total Degree Plan	41	34	40	1840	60

Total Degree Plan hours *(above)*

Note: Consider pre-requisites when sequencing courses

Do other colleges offer this program?	NLC	NVC	PAC	SAC	SPC
	N	Yes	Yes	Yes	Yes

Discussion and Possible Action on the Purchase of Facilities Custodial and Ground Services

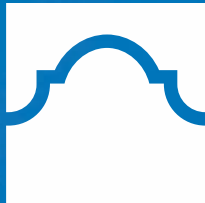

ALAMO
COLLEGES
DISTRICT

Greg McClure

Associate Vice Chancellor, Facilities & Construction Management



Action Requested

Approve the awarded contracts to; 1) Custodial Services to Prichard Industries LLC for \$5,511,873 and 2) Grounds Services to ABM Business and Industry for \$3,951,053 to purchase of Facilities Custodial and Grounds Services in the estimated annual amount of \$9,522,926 (includes forecast event setup fees) as requested by the Associate Vice Chancellor of Facilities Operations and Construction Management.



Thank you.

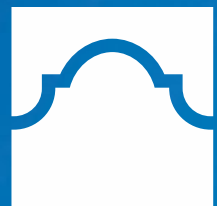

ALAMO
COLLEGES
DISTRICT



Discussion and Possible Action on the Purchase of Facilities Custodial and Ground Services

Presented to the Board Acting as Committee of the Whole on May 14, 2024 and now presented to the Board for approval on May 21, 2024.

MINUTE ORDER

“The Board of Trustees hereby awards the contracts to; 1) Custodial Services to Prichard Industries LLC for \$5,511,873 and 2) Grounds Services to ABM Business and Industry for \$3,951,053 to purchase of Facilities Custodial and Grounds Services in the estimated annual amount of \$9,522,926 (includes forecast event setup fees) as requested by the Associate Vice Chancellor of Facilities Operations and Construction Management.”

PURPOSE

This contract action provides for the purchase of Facilities Custodial and Ground Services. The quantities and orders will be purchased on an as needed basis and substantially based on the scope of work and the contract prices. The services are to be performed at all Alamo Colleges District locations/campuses (which include the five colleges, district offices, Central Texas Technology Center, First Responders Academy, and all off-campus satellite locations). The contractor(s) will provide the labor and tools required for completing Facilities Custodial and Ground Services.

BACKGROUND

A notice soliciting Competitive Sealed Proposals (CSP) was advertised in the San Antonio Express News, La Prensa, and San Antonio Observer twice over a thirty-day period. Additionally, Purchasing and Contract Administration sent notices to 126 potential Offerors. The twenty (20) proposals received by the CSP deadline were evaluated by representatives from Facilities Operation and Construction Management Department considering the Alamo Colleges' District specifications and requirements. As a result of this effort, the proposal submitted by is recommended for award on a best value basis.

An evaluation process to formally award multiple contracts to various Offerors was conducted to reduce the delays in repetitive bidding, expand the range of services, and to ensure services are available when needed. The amounts shown represent the Alamo Colleges District's best estimates for a one-year period, the amount paid will depend on the number of services purchased. Each contract will begin upon award and terminate June 30, 2027, and has three, one-year options to renew upon mutual consent of the Contractor and Alamo Colleges District.

IMPLICATIONS

Financial: \$9,522,926 institutional O&M funds, estimated annually

Strategic Objective: Goal I – Student Success; Goal III – Performance Excellence

Employee Services: None

ATTACHMENTS: Price Tabulation, Evaluation Criteria

Lisa L. Mazure, MSA, CPA, CGFM
Associate Vice Chancellor, Finance & Fiscal Svc



Dr. Tom Cleary
Interim Vice Chancellor for Finance & Administration

Gregory McClure
Associate Vice Chancellor, Facilities Operations and
Construction Management

Dr. Mike Flores
Chancellor



CUSTODIAL PROPOSAL TABULATION
Purchase of Facilities Custodial and Ground Services

Vendor	Tech Pnt Rank (best to worst)	Tech points	Cost Rank (low = "1")	Custodial Cost	Cost score **	Total score	Overall Rank
Pritchard Industries LLC	2	63.16	2	\$ 5,511,873	30.00	93.16	1
Caring Commerical Cleaning	6	59.78	3	\$ 5,699,672	29.01	88.80	2
ABM Business & Industry	1	58.59	11	\$ 8,607,802	19.21	77.80	3
Allied Universal Janitorial Services	11	54.55	5	\$ 7,157,355	23.10	77.65	4
Thompson Facility Services	4	56.72	9	\$ 8,146,996	20.30	77.02	5
McLemore Building Maintenance	15	49.65	4	\$ 6,513,531	25.39	75.04	6
IQS, Inc.	3	58.92	14	\$ 11,149,891	14.83	73.75	7
HHS INC.	10	56.35	1	\$ 3,877,724	17.36	73.71	8
AHI Facility Services, Inc	7	52.95	8	\$ 8,057,706	20.52	73.47	9
Amentum Commerical Operations, Inc.	9	57.24	12	\$ 10,415,669	15.88	73.12	10
HES Facilities, LLC	16	49.03	7	\$ 7,972,837	20.74	69.77	11
UBM Enterprise Inc	14	47.69	6	\$ 7,678,633	21.53	69.23	12
Ambassador Services LLC	12	47.75	10	\$ 8,492,439	19.47	67.22	13
Medina's Janitorial	8	56.95	18	\$ 16,366,748	10.10	67.05	14
Jani King	5	50.55	17	\$ 14,190,622	11.65	62.20	15
4M Building Solutions	17	43.92	16	\$ 12,209,596	13.54	57.47	16
DLP Services	13	43.24	15	\$ 12,107,652	13.66	56.90	17
Service Master Clean	18	37.62	13	\$ 10,930,227	15.13	52.75	18

CUSTODIAL PROPOSAL TABULATION
Purchase of Facilities Custodial and Ground Services

Vendor	Tech Pnt Rank (best to worst)	Tech points	Cost Rank (low = "1")	Grounds APPA 2 Cost	Cost score **	Total score	Overall Rank
ABM Buisness & Industry Grounds	1	61.85	6	\$ 3,951,053	20.53	82.38	1
McLemore Building Maintenance Grounds	6	44.39	5	\$ 2,813,559	28.83	73.22	2
4M Building Solutions Grounds	4	45.45	7	\$ 4,329,207	18.74	64.18	3
Allied Universal Grounds	8	33.89	4	\$ 2,703,855	30.00	63.89	4
Cutrite Landscaping	5	41.05	8	\$ 4,353,752	18.63	59.69	5
Amentum Commerical Operations, Inc. Grounds	7	39.55	3	\$ 1,623,303	10.03	49.58	6
Maldonado Nursery & Landscaping, Inc. Grounds	3	45.45	2	\$ 1,316,536	-1.61	43.83	7
Pritchard Industries LLC Yellowstone Landscaping Grounds	2	52.64	1	\$ 10,358	-	-	8



EVALUATION CRITERIA
Purchase of Facilities Custodial and Ground Services

Criteria	Maximum Points
1. Purchase Price	30
2. Experience, Qualifications and Ability to Perform	25
3. Reputation, References and Personnel structure.	25
4. Training, Safety, and Technical capabilities	10
5. SMWVBE	10
Total:	100

Contract for the Purchase of Facilities Custodial and Ground Services

Gregory McClure

Associate Vice Chancellor, Facilities Operations and
Construction Management

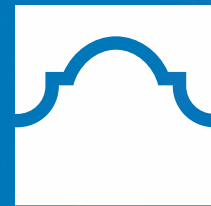

ALAMO
COLLEGES
DISTRICT



Malcolm Baldrige
National Quality Award

2018 Award Recipient



Great
Place
To
Work[®]

Certified
MAR 2024-MAR 2025
USA

Board Policies in Support of Charges

C.2.3 Facilities and Grounds Management

- Maintenance and Operations:
The College District shall ensure that its facilities are safe, comfortable, and hygienic for students, faculty, employees, and the general public. Consistent maintenance standards shall be employed throughout the College District.

Charges to the Chancellor

Institutional Excellence and Continuous Improvement



Purpose

- Provides for the purchase of Facilities Custodial and Ground Services.
- The services are to be performed at all Alamo Colleges District locations/campus (the five colleges, ACCESS, Central Texas Technology Center, First Responders Academy, and all off-campus satellite locations).
- The contractors will provide the labor and tools required for completing Facilities Custodial and Ground Services.



Recommended Contract Action

Type of Contract Action: Awarding contracts for the purchase of Facilities Custodial and Ground Services

Vendors

1. Custodial Services to Prichard Industries LLC for \$5,511,873
2. Grounds Services to ABM Business and Industry for \$3,951,053

Total Award Amount: \$9,522,926 (institutional funds)

Contract Term: Through June 30, 2027 (plus three-one-year options)

Local Vendors: Both have San Antonio offices

SMWVBEs: 35% subcontract participation for Pritchard
ABM Business and Industry did not quantify in proposal

Thank you.

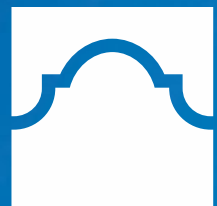

ALAMO
COLLEGES
DISTRICT



Background

- A notice soliciting Request for Proposals (RFQ) was advertised in the San Antonio Express News and La Prensa de San Antonio twice over a thirty-day period. Additionally Purchasing & Contract Administration sent notices to 126 potential Offerors.
- The 20 proposals received by the RFP deadline were evaluated by representatives from Facilities Operations and Construction Management Department.
- The proposals are recommended for award on a best value basis.

Discussion and Possible Action to Approve Four Guaranteed Maximum Prices and Associated Construction Manager at Risk Contract for Alamo Colleges District – Maintenance Tax Note 2022 Funded Projects for San Antonio College and St. Philip’s College

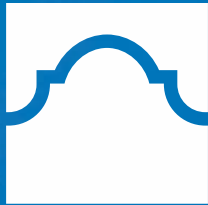

ALAMO
COLLEGES
DISTRICT

Greg McClure

Associate Vice Chancellor, Facilities & Construction Management



Action Requested

Approve the Guaranteed Maximum Prices (GMPs) and associate Construction Manager at Risk (CMAR) contract awards, subject to subsequent execution of agreements in form acceptable to District Counsel, as requested by the Associate Vice Chancellor for Facilities Operations and Construction Management.



Thank you.

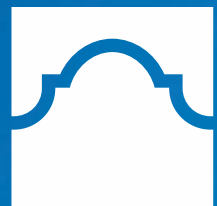

ALAMO
COLLEGES
DISTRICT



Discussion and Possible Action to Approve Guaranteed Maximum Prices for Construction Manager at Risk Contracts

- San Antonio College
- St Philip's College

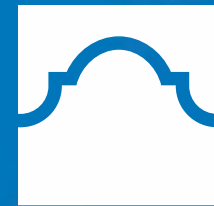

ALAMO
COLLEGES
DISTRICT

Greg McClure

Associate Vice Chancellor, Facilities & Construction Management



Board Policies in Support of Charges

C.2.3 Facilities and Grounds Management

- Maintenance and Operations: *The College District shall ensure that its facilities are safe, comfortable, and hygienic for students, faculty, employees, and general public. Consistent maintenance standards shall be employed throughout the College District. Periodic assessments of the condition of College District facilities shall be conducted.*
- Preventive Maintenance: *The College District administration shall prepare, budget, and execute an annual preventive maintenance program.*

Charges to the Chancellor

- *Institutional Excellence and Continuous Improvement (charge 8)*





GROUNDBREAKING FUTURES



\$450M Capital Investment; General Obligation bond in 2017



\$50M Capital Investment; Maintenance Tax Notes in 2019



\$270M Investment to extend life of aging facilities; Maintenance Tax Notes in 2022



\$58.5M over 3-years to sustain existing facilities, Preventive Maintenance Budget 2022-25





GROUNDBREAKING FUTURES



Strategically
Invest in
Learning
Environment



Increase
Access to
Technology



Enhance
Student
Safety



Reduce Energy
Consumption and
Improve
Sustainability



Increase Stewardship
– Restore & Preserve
High-Value Facility
Portfolio





ALAMO COLLEGES DISTRICT
San Antonio College

GROUNDBREAKING

FUTURES

\$246.8M

**San Antonio College
Total Investment**



\$83M Capital Investment

General Obligation bond in 2017



\$11.1M Capital Investment

Maintenance Tax Notes in 2019



\$148.6M Investment to extend life of aging facilities

Maintenance Tax Notes in CY2022



\$4.1M over 3-years to sustain existing facilities

Preventive Maintenance Budget FY2023-25



ALAMO
COLLEGES
DISTRICT



Project Scope

MTN SAC Contract Package 3 – Full Facility Renovation

- McAllister Fine Arts Center
- \$11,713,122 GMP/Contract amount

CMAR: Guido Construction

- Local Office: Yes, headquarters in San Antonio
- SMWVBE: 20% (anticipated participation)



Project Scope

MTN SAC Contract Package 8 – Major Systems (HVAC) Renovation

- Loftin Student Center
- Moody Learning Center
- \$7,207,064 GMP/Contract amount

CMAR: Byrne Construction Services

- Local Office: Yes, headquarters in Forth Worth, TX
- SMWVBE: 21% (anticipated participation)





ALAMO COLLEGES DISTRICT
St. Philip's College

GROUNDBREAKING

FUTURES

\$247M

**St. Philip's College
Total Investment**



\$81.9M Capital Investment

General Obligation bond in 017



\$10.9M Capital Investment

Maintenance Tax Notes in 2019



\$46.2M Investment to extend life of aging facilities

Maintenance Tax Notes in 2022



\$8.19M over 3-years to sustain existing facilities

Preventive Maintenance Budget 2022-25



\$100 M Capital investment

Title III and HEERF Facilities Investment since 2017



ALAMO
COLLEGES
DISTRICT



Project Scope

MTN SPC Contract Package 1 – EETC

- Eastside Education & Training Center
- \$17,122,832 GMP/contract amount

CMAR: Gilbane Building Company

- Local Office: Yes, headquarters in Providence, RI
- SWMVBE: 30% (anticipated participation)



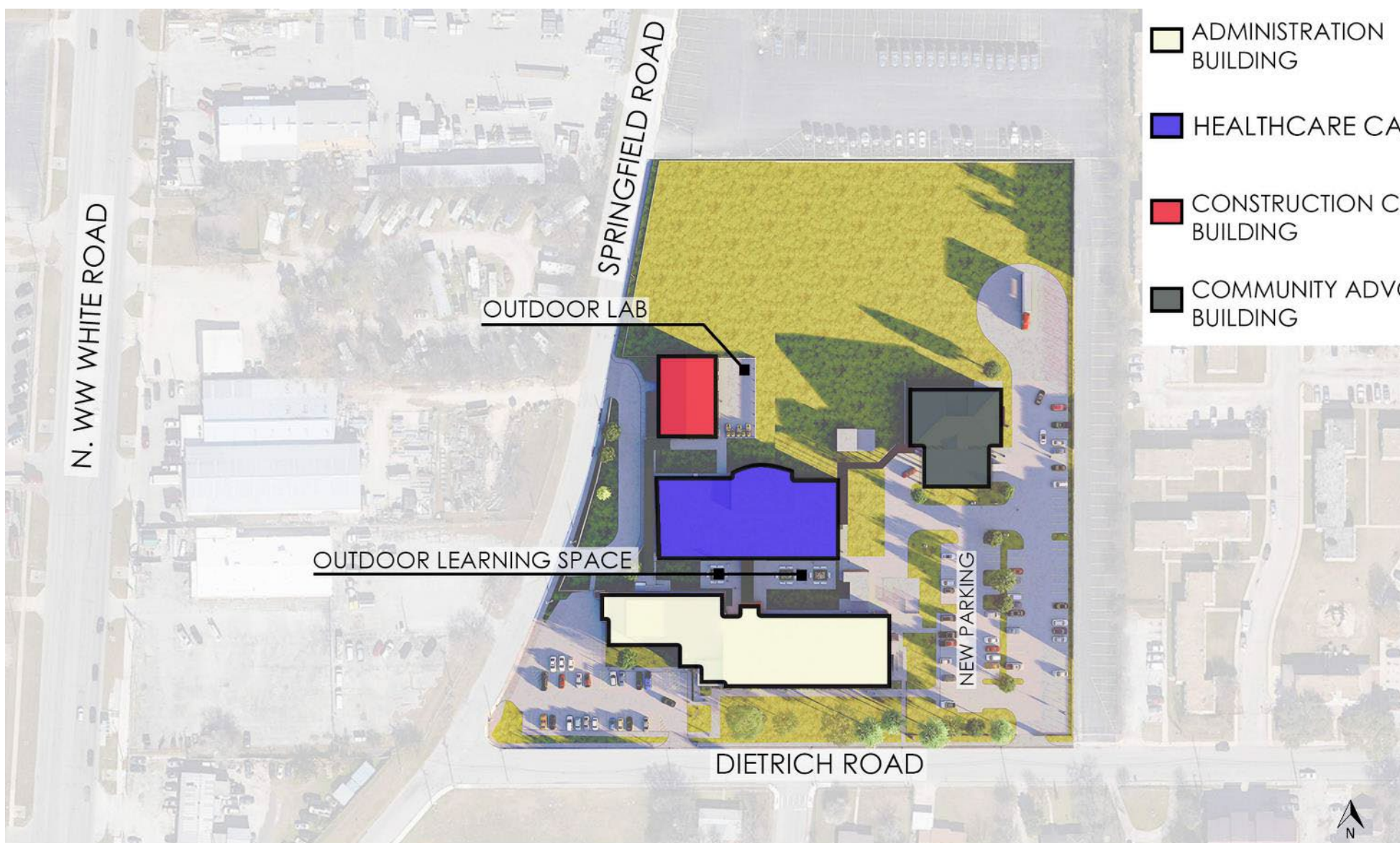

- ADMINISTRATION BUILDING
- HEALTHCARE CAREERS
- CONSTRUCTION CAREERS BUILDING
- COMMUNITY ADVOCACY BUILDING

OVERALL SITE PLAN

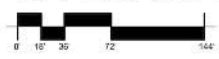

ADMINISTRATION BUILDING



PROPOSED SIDEWALK CONNECTING
NEW PARKING TO MAIN ENTRANCE



VIEW FROM DIETRICH ROAD



OUTDOOR LEARNING SPACE



VIEW TOWARDS WEST



VIEW TOWARDS EAST



ALAMO
COLLEGES
DISTRICT



HEALTHCARE CAREERS



VIEW FROM ENTRY



VIEW FROM PRACTICE BEDS



ALAMO
COLLEGES
DISTRICT



CONSTRUCTION CAREERS



VIEW FROM HEALTHCARE CAREERS



VIEW FROM THE BUS LOOP



ALAMO
COLLEGES
DISTRICT



CONSTRUCTION CAREERS



VIEW FROM FRONT OF CONSTRUCTION LAB



VIEW FROM BACK OF CONSTRUCTION LAB



ALAMO
COLLEGES
DISTRICT



Project Scope

MTN SPC Contract Package 2 – Comprehensive Renovations

- Cntr for Health Professions, Welcome Ctr and Cntr for Learning Resources (library), Campus Security Bldg, Chiller Bldg., Cont. Ed, Maint. Shop
- \$12,534,940 GMP/Contract amount

CMAR: Turner Construction

- Local Office: Yes, headquarters in New York, NY
- SWMVB: 30% (anticipated participation)



May 2024 Board Action:

Discussion and Possible Action to Approve four Guaranteed Maximum Prices and Associated Construction Manager at Risk Contracts for Alamo Colleges District – Primarily Maintenance Tax Note 2022-Funded Projects for San Antonio College

1. GMP with **Guido Construction** in the amount of **\$11,713,122** for San Antonio College's Maintenance Tax Note funded Contract Package 3; full facility renovation for McAllister Fine Arts Center
2. GMP with **Byrne Construction Services** in the amount of **\$7,207,064** for San Antonio College's Maintenance Tax Note funded Contract Package 8; Major System (HVAC) renovation for Loftin Student Center and Moody Learning Center.
3. GMP with **Gilbane Building Company** in the amount of **\$17,122,832** for St. Philip's College's Maintenance Tax Note funded Contract Package ; full facility renovation for Eastside Education & Training Center. Also approves use of institutional (preventive maintenance) funds for new construction.
4. GMP with **Turner Construction** in the amount of **\$12,534,940** St. Philip's College's Maintenance Tax Note funded Contract Package 2; Comprehensive Renovation for CHP, Welcome Ctr and CLR, Campus Security Bldg, Chiller Bldg., Cont. Ed, Maint. Shop Comp



Thank you.

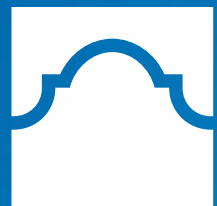

ALAMO
COLLEGES
DISTRICT



Alamo Colleges MTN Schedule Overview

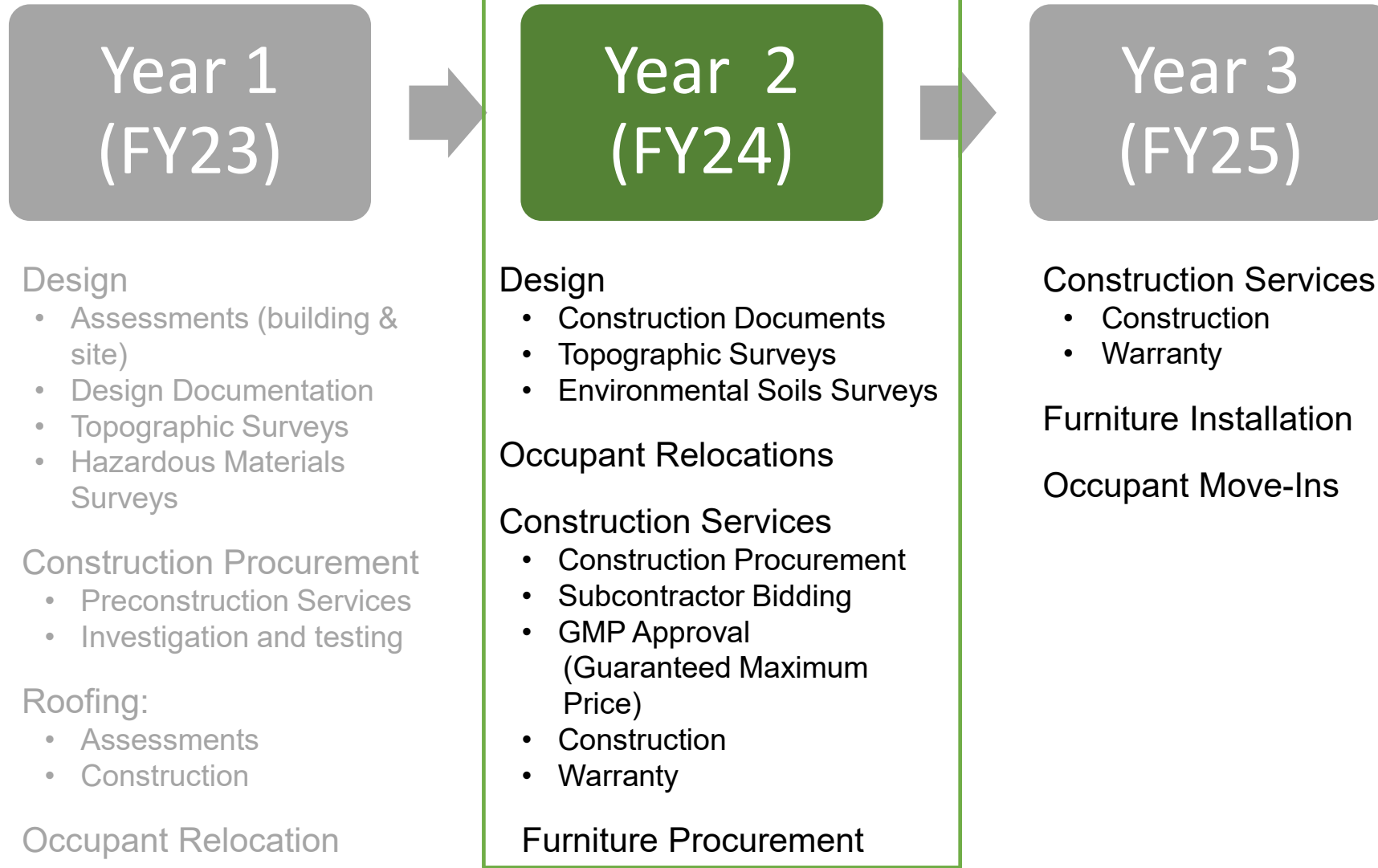

Energy and Sustainability Impacts of MTN and PM Investment

- **Project Types**
 - Facility Renovation, Major System Rehabilitation (Roof and HVAC), and Preventive Maintenance Projects
- **MTN and PM Opportunities for Sustainability and Energy Reduction**
 - HVAC System, Exterior Enclosure, Roofing
 - Conform to current Energy Code, Updated HVAC Controls, Insulation, Reduce Moisture Intrusion & Outside Air
 - Investing \$117 M of MTN and PM Funds in these System Types
- **Energy Standards**
 - ASHRAE 90.1, adopted by Texas
 - 2018 International Energy Conservation Code (IECC), adopted by the city of San Antonio
- **Alamo Colleges Standards**
 - Water-wise fixtures and irrigation systems
 - Energy-Star rated HVAC/R systems and appliances
 - LED lighting; building automation and lighting controls
 - Energy-efficient windows, doors, skylights & frames (low-E glass/UV tint/thermal control)
 - Energy-efficient roofing (increased R-value & reflective surfaces), etc.

Background, Board Actions

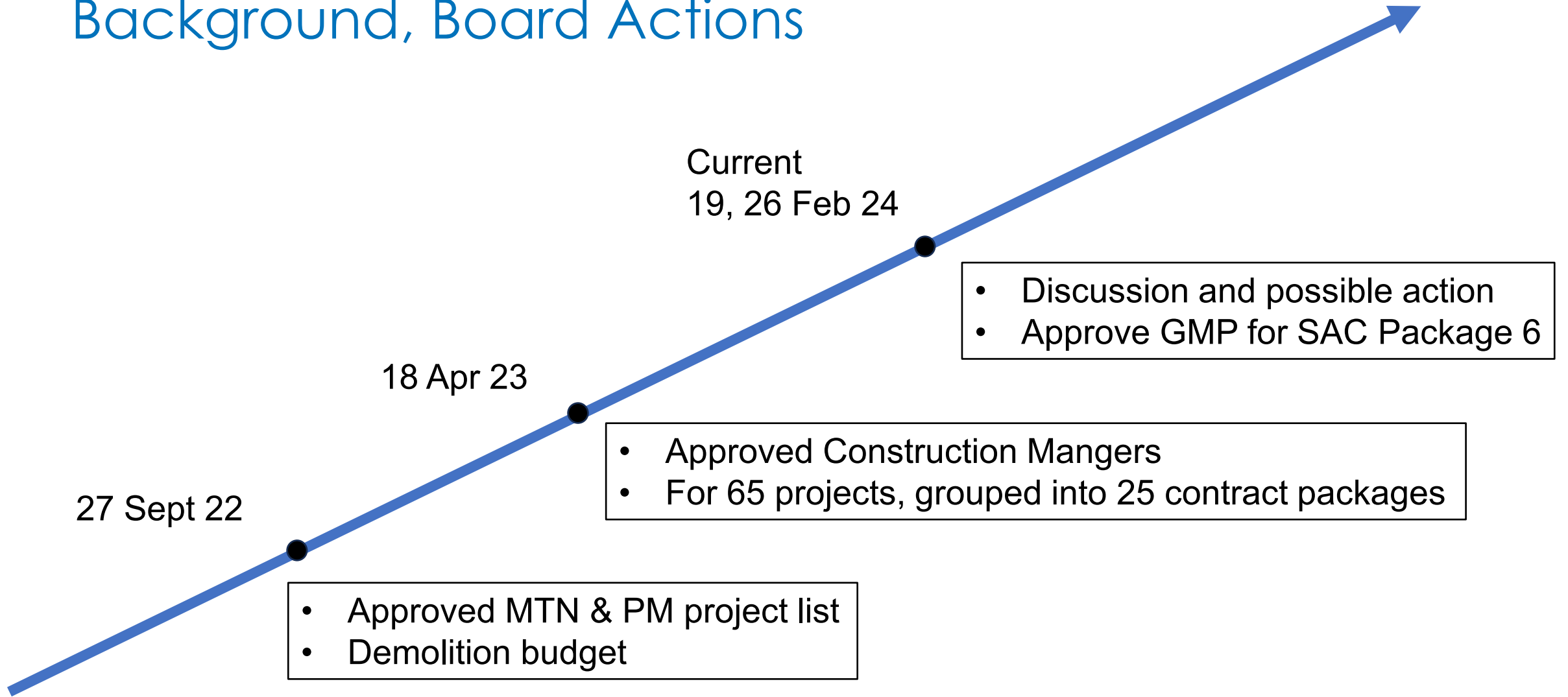

Background

- September 27, 2022 Board Actions
 - Approved project list for Maintenance Tax Note Funding
 - Approved project list for Preventive Maintenance Funding
 - Approved Demolition budget for select buildings replaced by recent /ongoing new construction
- April 18, 2023 Board Actions
 - Approved the pool of qualified construction managers
 - 65 separately named projects, District-wide – grouped into 25 contract packages
- Current
 - Designs for contract packages are nearing completion
 - Guaranteed Max Price Approvals projected for coming months, this package is the 4th before the Board

Outcomes of this Program (MTN funded renovations)

- Strategic Investment to **Prolong the Existence of Current Facilities** --- through MTN Funds
- Proactively **Augment Facilities** to Increase energy saving, Upgrade technology systems and Upgrade building security

Discussion and Possible Action to Approve four Guaranteed Maximum Prices and Associated Construction Manager at Risk Contracts for Alamo Colleges District - Maintenance Tax Note 2022-Funded Projects for San Antonio College, St. Philip's College.

Presented to the Board Acting as Committee of the Whole on May 14, 2024, and now presented to the Board for approval on May 21, 2024.

MINUTE ORDER

"The Board of Trustees hereby approves the following Guaranteed Maximum Prices (GMPs) and associated Construction Manager at Risk (CMAR) contract awards, subject to subsequent execution of agreements in form acceptable to District Counsel, as requested by the Associate Vice Chancellor for Facilities Operations and Construction Management.

- **GMP with Guido Construction in the amount of \$11,713,122 for San Antonio College's Maintenance Tax Note funded Contract Package 3; full facility renovation for McAllister Fine Arts Center.**
- **GMP with Byrne Construction Services in the amount of \$7,207,064 for San Antonio College's Maintenance Tax Note funded Contract Package 8; major systems (HVAC) renovation for Loftin Student Center and Moody Learning Center.**
- **GMP with Gilbane Building Company in the amount of \$17,122,832 for St. Philip's College's Maintenance Tax Note funded Contract Package 1; full facility renovation for Eastside Education & Training Center.**
- **GMP with Turner Construction in the amount of \$12,534,940 for St. Philip's College's Maintenance Tax Note funded Contract Package 2; Comprehensive Renovation for CHP, Welcome Ctr and CLR, Campus Security Bldg, Chiller Bldg., Cont. Ed, Maint. Shop Comp.**

The board also approves use of Preventive Maintenance funds allocated to the Eastside Education and Training Center for new construction items such as covered areas, the outdoor construction technology learning space, and new pavement for improved access."

PURPOSE

To approve the GMPs and associated CMAR contract awards for the four above indicated contract packages which include critically needed mechanical systems repair and renovation work located at San Antonio College and St. Philip's College. Fund sources are primarily Maintenance Tax Notes, but include Preventive Maintenance funds and Title III funds for St Philip's College Black Box Theater addition.





BACKGROUND

September 27, 2022 Board Actions

- Approved project list for Maintenance Tax Note Funding
- Approved project list for Preventive Maintenance Funding
- Approved demolition budget for select buildings replaced by recent /ongoing new construction

April 18, 2023 Board Actions

- Approved the pool of qualified construction managers

The MTN22 Program includes 65 separately named projects, District-wide – grouped into 25 contract packages to simplify contracting activities.

The scope of the work primarily includes repair and replacement of various facility systems which are past or at the end of useful life; water distribution, natural gas service, mechanical/HVAC systems, building automation controls, electrical distribution, lighting, and fire and life safety systems. Work also includes some associated interior finish work.

IMPLICATIONS

Financial: Maintenance Tax Note CY2022 Bond funds; Institutional Funds (budgeted Preventive Maintenance), and Title III Grant

Objective: I. Student Success and III. Performance Excellence

Employee Services: None

ATTACHMENTS: Presentation

Lisa L. Mazure, MSA, CPA
Associate Vice Chancellor Finance &
Fiscal Services

Gregory L. McClure
Vice Chancellor for Facilities
Operations & Construction Management



Dr. Tom Cleary
Interim Vice Chancellor for
Finance & Administration

Dr. Mike Flores
Chancellor

Discussion and Possible Action on the Purchase of Construction Services for Palo Alto College Building 6, Student Commons Underfloor and Site Drainage Improvements

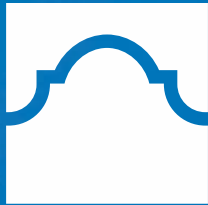

ALAMO
COLLEGES
DISTRICT

Mr. Lacy Hampton

Interim Associate Vice Chancellor
G.O. Bonds Capital Program (CIP)



Action Requested

Approve the award of a Job Order Contract through Region 20 cooperative purchase agreement to SpawGlass Contractors Inc. providing for the purchase of construction services for Alamo Colleges to make improvements to the underfloor and site drainage at Palo Alto College Building 6, Student Center for a cost of \$1,498,657 as requested by the Associate Vice Chancellor for Facilities Operations and Construction Management.



Thank you.

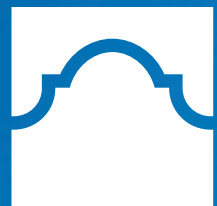

ALAMO
COLLEGES
DISTRICT



Discussion and Possible Action on the Purchase of Construction Services for Palo Alto College Building 6, Student Commons Underfloor and Site Drainage Improvements

Presented to the Board Acting as Committee of the Whole on May 14, 2024 and now presented to the Board for approval on May 21, 2024.

MINUTE ORDER

"The Board of Trustees hereby approves award of a Job Order Contract through Region 20 cooperative purchase agreement to SpawGlass Contractors Inc. providing for the purchase of construction services for Alamo Colleges to make improvements to the underfloor and site drainage at Palo Alto College Building 6, Student Center for a cost of \$1,498,657 as requested by the Associate Vice Chancellor for Facilities Operations and Construction Management."

PURPOSE

To award a job order contract for construction services to make improvements to the underfloor and site drainage at Palo Alto College Building 6, Student Center.

BACKGROUND

The contract will be awarded via the Region 20 COOP Job Order Contract Purchasing. Contract Administration utilizes the Cooperative Purchase Programs (COOP) to gain greater access to goods and services, cost savings through leveraged buying, and reduced administration costs by issuing fewer competitive bids and proposals. The combined buying power of public institutions throughout the State of Texas and nationally translates into savings and provides an efficient, cost effective and legal means for providing goods and services to departments throughout the Alamo Colleges District in an expedited fashion. Vendor contracts awarded through approved federal, state or cooperative purchasing agreements are a statutorily approved alternative to competitively procured vendor contracts.

The Job Order Contracts Method can be used to procure maintenance, repair, alteration, renovation, remediation, or minor construction of a facility if the governing body of a governmental entity shall approve each job, task, or purchase order that exceeds \$500,000. As such, this purchase is recommended in accordance with the Texas Government Code 2269 Contracting and Delivery Procedures for Construction Projects, Subchapter I Job Order Contracts Method.

FINANCIALS \$1,498,657 contract with \$1,603,590 Total Project cost; PM23 Institutional Funds
Strategic Plan: Goal II – Principle-Centered Leadership; Goal III Performance Excellence

Lisa L. Mazure, MSA, CPA.
Assoc Vice Chancellor for Finance and
Fiscal Services

Gregory L. McClure
Assoc. Vice Chancellor for Facilities Operations
and Construction Management



Dr. Thomas S. Cleary
Interim Vice Chancellor for Finance & Admin.

Dr. Mike Flores
Chancellor



Discussion and possible action to approve contract award for - Building #6 Student Commons Underfloor and Drainage Improvement Project

- Palo Alto College

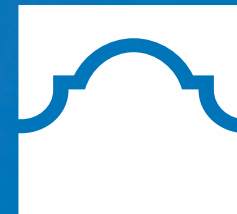

ALAMO
COLLEGES
DISTRICT

Mr. Greg McClure

AVC, Facilities Operations & Construction Management

May 2024



Board Policies in Support of Charges

- *C.2.3 Facilities and Grounds Management*
- *Construction Management:* The College District shall establish standards for all College District facilities, in accordance with federal, state, and local law and regulations. No construction, with the exception of routine maintenance, shall be initiated without Board approval. All construction delivery methods shall be selected and conducted pursuant to relevant law.
- *Facilities Planning:* The College District shall operate a continuing Capital Improvement Program based on College District needs, taking into account enrollment, operations, and acquisition of property. Facilities planning shall be inclusive of program needs and facilities standards in a manner consistent with the master plan.

Charges to the Chancellor

- *Student equity and Success*
- *College Access and Completion*
- *Institutional Excellence and Continuous Improvement*



PAC SITE - Building Location



Purpose

The Palo Alto College Student Center improvement project will take place under the floor and at the perimeter of the building. The work for this project includes the installation of a concrete mud slab, underground storm drains, the excavation and installation of a French drain, two sump pumps, concrete swales, general flatwork, electrical, irrigation, grading, and landscaping.

Project information:

- **Civil Engineer:** Bain Median Bain
- **COOP:** Region 20
- **Project Budget:** \$1,498,657.00
- **Estimated Construction Start:** June 2024
- **Estimated Completion:** January 2025



BUILDING #6 College Student Center



Minute Order Action

Discussion and possible action to approve contract award for Alamo Colleges District Palo Alto College - Building #6 Student Center Underfloor and Drainage Improvement Project

- Approves \$1,498,657.00 contract award with SpawGlass Contractors Inc. plus additional 5% owner's contingency held outside the contract
- Award is through Region 20 Cooperative Purchase Agreement



Thank you.

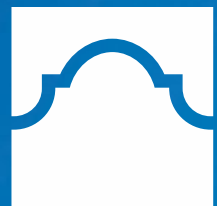

ALAMO
COLLEGES
DISTRICT



Recommended Contract Award

- **Type of Contract Action:** COOP Region 20
- **Vendor:** SpawGlass Contractors Inc.
- **Award Amount:** : \$1,498,657.00
- **Contract Term:** 7 months performance period
- **Local Vendor:** San Antonio Contractor
- **Funding:** PM23



STUDENT COMMON CENTER MAIN ENTRANCE



Project Information:

Building Information: 21,146 SF, One Story
Kitchen (2) Dining Rooms, College Store,
(20) Offices, Workout Room, and Outdoor Patios

Construction Type:

- Construction Type IIB
- Primary Structure: Steel / Suspended Slab
- Envelope: Masonry / Storefront Window systems
- Mechanical System: Chilled Water
- Landscape: Planting & Irrigation
- AHJ: City of San Antonio, Texas



STUDENT COMMON CENTER MAIN ENTRANCE



ALAMO
COLLEGES
DISTRICT



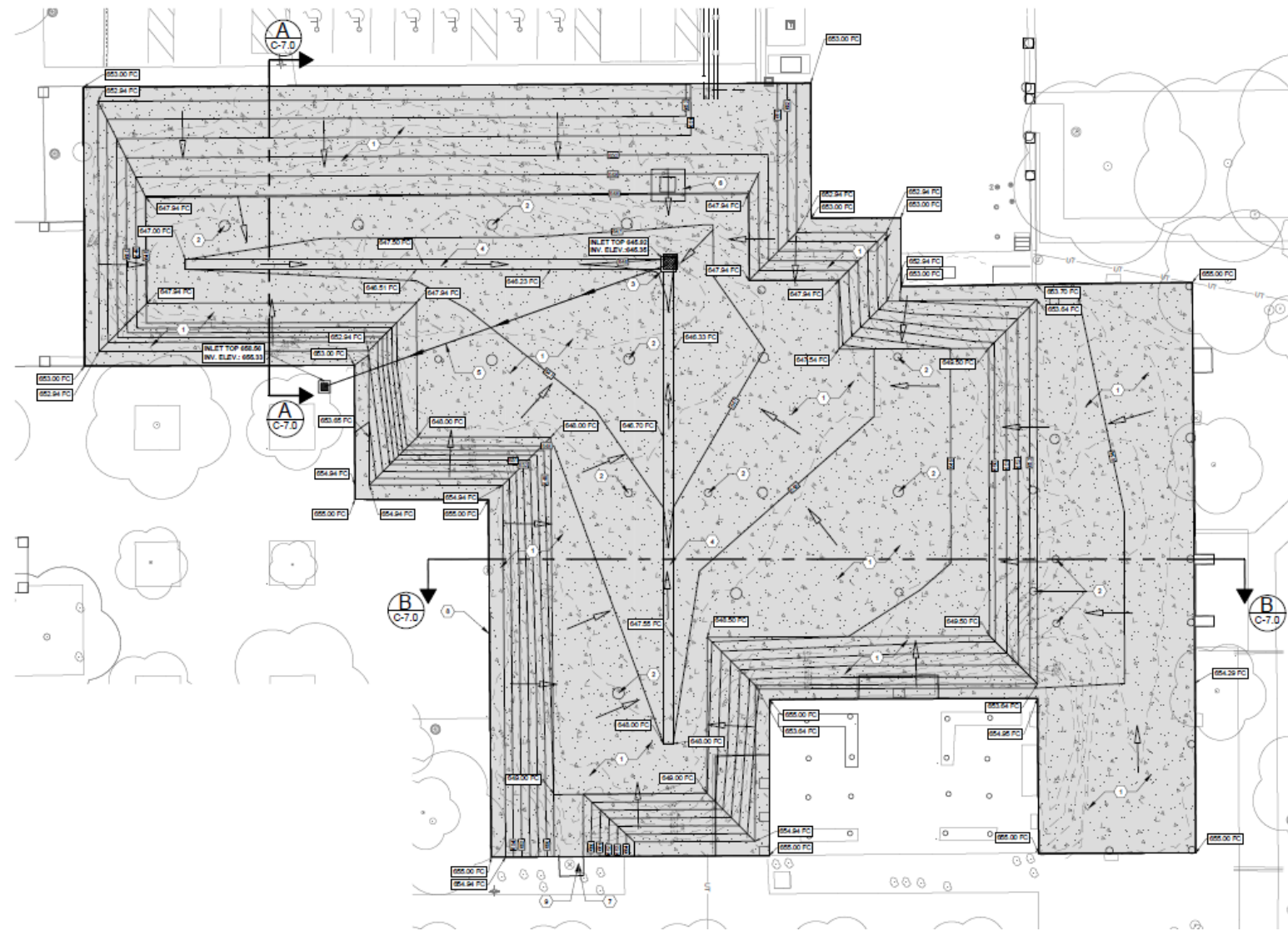

UNDERFLOOR GRADING PLAN

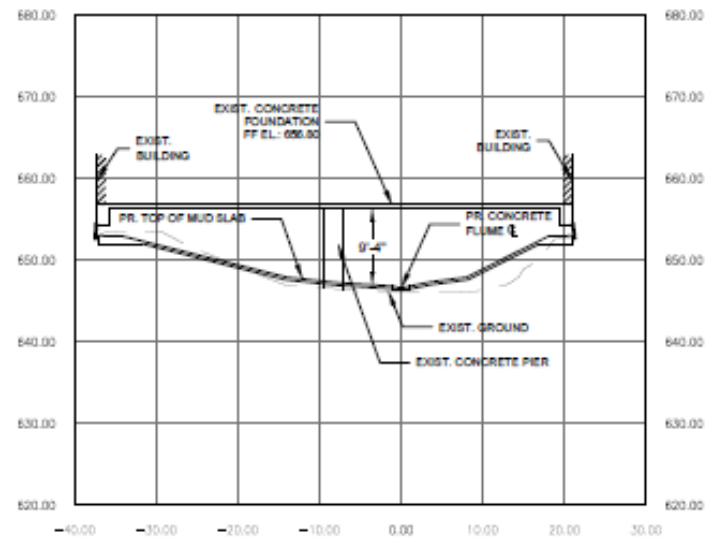

UNDERFLOOR SECTION - AA

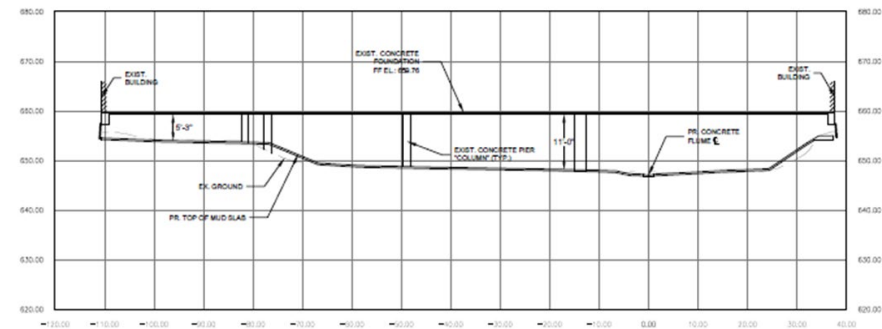

UNDERFLOOR SECTION - BB



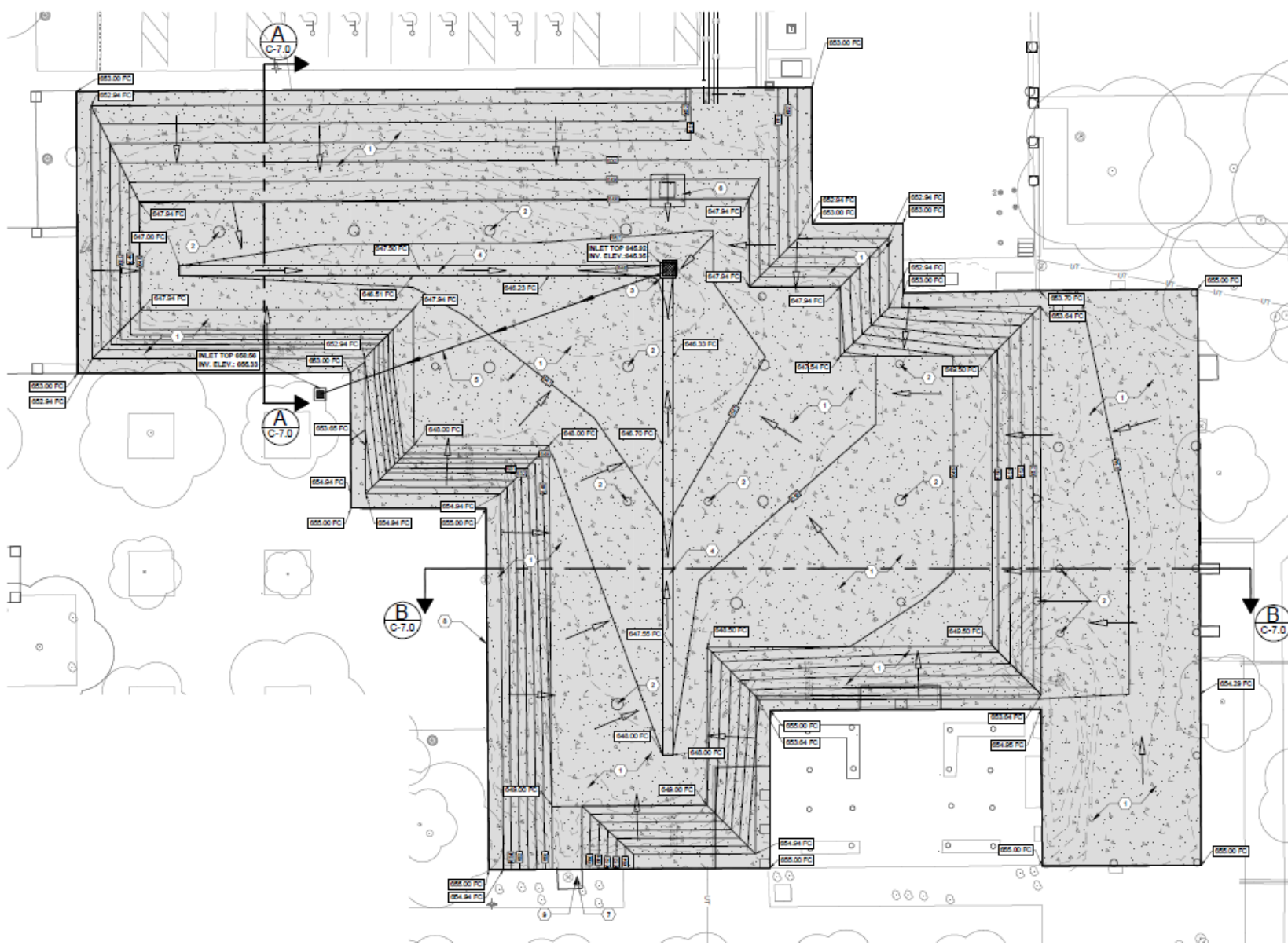

UNDERFLOOR GRADING PLAN



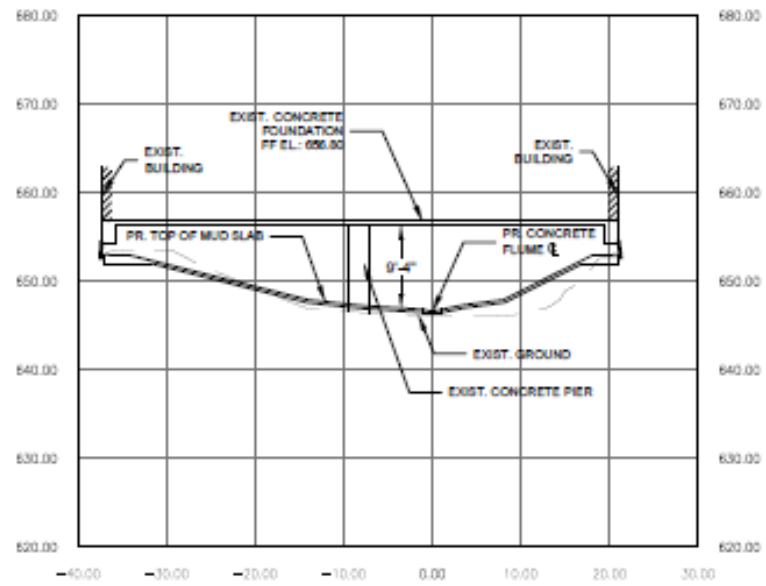

UNDERFLOOR SECTION - AA

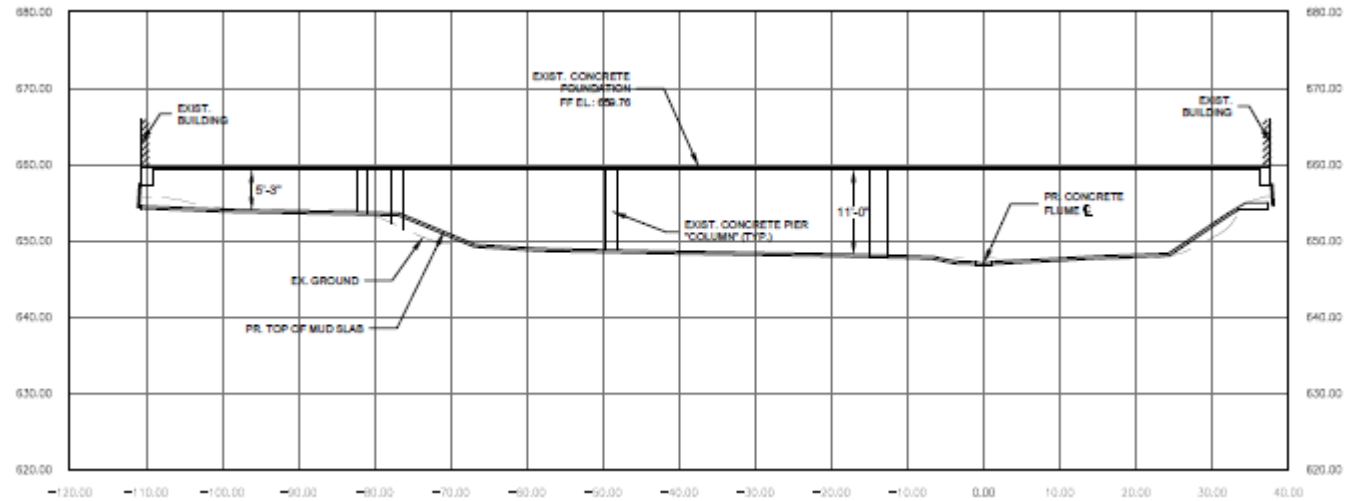

UNDERFLOOR SECTION - BB





UNDERFLOOR ELECTRICAL BUS



UNDERFLOOR SUMP PUMP LOCATION



BACKGROUND

- Proposals were requested from multiple COOP Contractors.
- Seven construction contractors were solicited and two submitted proposal (Spawglass Construction Inc. And Sullivan Construction). The responding contractors submitted COOP proposals and were evaluated with a best value source selection approach and Spawglass Construction Inc. was selected.
- Original PM23 Budget: \$1,426,807.00

Description	Cost	Fund Source
Project Design	\$25,000.00	PM Funds
Other Soft Costs	\$5,000.00	PM Funds
Construction Award Cost	1,498,657.00	PM Funds
Contingency (5%)	74,933.00	PM Funds
Total Project Costs	\$1,603,590.00	PM Funds



Discussion and Possible Action on Guaranteed Maximum Price or Alamo Colleges District – Northwest Education and Training Center Capital Improvement Project (CIP), Construction Manager-at-Risk Contract with Thomas S. Bryne D/B/A Bryne Construction Services

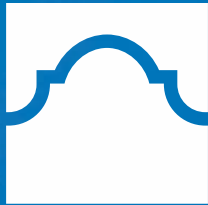

ALAMO
COLLEGES
DISTRICT

Mr. Lacy Hampton

Interim Associate Vice Chancellor
G.O. Bonds Capital Program (CIP)



Action Requested

Approve the Guaranteed Maximum Price Construction Manager-at-Risk fee negotiated with Thomas S. Byrne D/B/A Bryne Construction Services in the amount of \$24,895,138 (including contingency) for the construction of the Alamo Colleges District – Northwest Education and Training Center Capital Improvement Project (CIP), subject to subsequent execution of GMP amendment acceptable to District counsel by Chancellor or delegate.



Thank you.

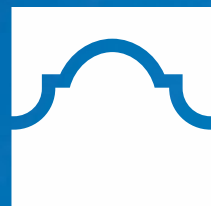

ALAMO
COLLEGES
DISTRICT



Discussion and Possible Action on Guaranteed Maximum Price for Alamo Colleges District – Northwest Education and Training Center Capital Improvement Project (CIP), Construction Manager-at-Risk Contract with Thomas S. Byrne D/B/A Byrne Construction Services. (CSP 18C-005)

Presented to the Board Acting as Committee of the Whole on May 14, 2024 and now presented to the Board for approval on May 21, 2024.

MINUTE ORDER

“The Board of Trustees hereby approves the Guaranteed Maximum Price Construction Manager-at-Risk fee negotiated with Thomas S. Byrne D/B/A Byrne Construction Services. in the amount of \$24,895,138 (including contingency) for the construction of the Alamo Colleges District – Northwest Education and Training Center Capital Improvement Project (CIP), subject to subsequent execution of GMP amendment acceptable to District counsel by Chancellor or delegate.

PURPOSE

To approve the Guaranteed Maximum Price Construction Manager-at-Risk fee negotiated with Thomas S. Byrne D/B/A Byrne Construction Service in an amount not to exceed \$24,895,138 for the construction of the Alamo Colleges District – Northwest Education and Training Center Capital Improvement Project (CIP) subject to staff confirmation of scope and subsequent execution of GMP amendment.

BACKGROUND

In February 27, 2018, the Board approved the purchase of Construction Manager-at-Risk Services for the District for the General Obligation Bond Projects. Alamo Colleges District staff, the Construction Program Manager and the Architect have negotiated with the contractor for a Guaranteed Maximum Price (GMP) of \$24,895,138 (including contingency) for this work. The GMP as presently drafted includes \$27,090 Pre-Construction Services, \$1,401,215 General Conditions Cost, and \$712,586 Construction Phase Fee. The Construction Program Manager, Architect, and Construction Manager-at-Risk have analyzed a variety of value engineering alternatives for this project. This draft GMP represents the best value for Alamo Colleges District.

MAJOR FEATURES

The Northwest Education and Training Center is a multi-use two (2) story new 40,530 square foot facility for Alamo Colleges District. The newly designed campus facility will house general and computer classrooms, tutoring and testing rooms, instructional spaces, faculty suites, a student welcome center & counseling, and student collaboration and lounge area. The location is north of IH-10 seated in the Boerne Independent School District.

IMPLICATIONS

Financial: GMP: **\$24,895,138** of Total Project Costs of **\$30,386,289**. (\$23M of G.O. Bonds + \$6.5M Institutional and \$882K Real Estate Savings) will fund **\$24,895,183** of construction costs and **\$5,491,151** of project soft and hard costs and FFE.

Strategic Objective: Goal I – Student Success; Goal III – Performance Excellence

SWMBE/HUB Participation: 24%

Employee Services:

ATTACHMENTS: Building and Site Plan, Project Summary Sheet

Xavier Urrutia
Interim Vice Chancellor of Economic &
Workforce Development



Dr. Thomas S. Cleary
Interim Vice Chancellor for Finance & Administration

Lacy Hampton
Interim Associate Vice Chancellor
G.O. Bond Construction Improvement Program (CIP)



Dr. Mike Flores
Chancellor

Capital Improvement Program - Project Summary



General Information

Location/Campus:	Higher Education Regional Centers	Bond Tranche #:	2
Project Title:	I-10 Northwest Education and Training Center	Orig. Target Completion:	11/12/2021
Project Type:	New Building	Rev. Target Completion:	12/4/2025
Project Manager:	Joe Martinez	Target Square Footage:	30,000 40,530
Architect/Engineer:	Overland Partners	Construction Manager:	Thomas S. Byrne D/B/A Byrne Const. Svcs.
Project Description:	The 2017 CIP project is part of the Alamo Colleges District Higher Education Regional Center / Campus network, designed to increase access to higher education services for high residents of growth sectors in Bexar County. The plan is to build the facility to meet higher education facility standards and to attain approval to offer accredited academic and workforce degree programs and courses.		
		Furniture:	SKG Texas

Revenue Source		Projected Costs	
Gen. Oblig. Bonds	\$ 23,000,000	Current Estimated GMP Costs	\$ 24,895,138
Real Estate Savings	\$ 882,000	Current Estimated Hard Costs	\$ 269,632
Institutional Funds	\$ 6,504,289	Current Estimated Soft Costs:	\$ 3,693,819
		Current Estimated FF&E Costs:	\$ 1,527,700
	\$ -		
	\$ -		
Total Revenue:	\$ 30,386,289	Total Projected Costs:	\$ 30,386,289

GO17 Bond Funded Expenditure Budget

	Original Budget	Revisions	Revised Budget	Encumbrances	Expenditures	Remaining Budget
Land Costs: Southwest Appraisal Group	\$ 4,000	\$ 4,000	\$ 4,000	\$ -	\$ 4,000	\$ -
Pre-Construction: Sundt Construction	\$ 65,632	\$ 65,632	\$ 65,632	\$ -	\$ 65,632	\$ -
Pre-Construction: Byrne Construction	\$ 27,090	\$ 27,090	\$ 27,090	\$ 11,120	\$ 15,970	\$ -
Construction GMP: Byrne Construction	\$ 15,333,333	\$ 4,306,985	\$ 19,640,318	\$ -	\$ -	\$ 19,640,318
Arch.: Overland	\$ 1,533,333	\$ 1,148,619	\$ 2,681,952	\$ 395,027	\$ 2,286,925	\$ -
Const. Mtrls. Testing: Terracon	\$ 306,667	\$ (257,859)	\$ 48,808	\$ -	\$ 48,808	\$ -
Spclzd. Engineering Svcs: Bain Medina Bain	\$ 153,333	\$ 258,450	\$ 411,783	\$ 47,600	\$ 364,183	\$ (0)
Bldg Permit & Printing Fees: 74108	\$ 153,334	\$ (151,467)	\$ 1,867	\$ -	\$ 1,867	\$ (0)
Development Fees: 74102 Protection Dvlp.	\$ 500	\$ 500	\$ 500	\$ -	\$ 500	\$ -
Public Art:	\$ 153,333	\$ (153,333)	\$ 0	\$ -	\$ -	\$ 0
F,F&E:	\$ 5,366,667	\$ (5,248,617)	\$ 118,050	\$ 95,031	\$ -	\$ 23,019
	\$ -	\$ -	\$ -	\$ -	\$ -	\$ -
Total Bond Funded Budget:	\$ 23,000,000	\$ -	\$ 23,000,000	\$ 548,778	\$ 2,787,886	\$ 19,663,336
Variance from Bond Revenue:	\$ -					

Budget Comments: This project includes \$23M of GO17 Bonds plus \$7.386M of INSTL funds. The project scope changes include Redesign efforts to eliminate Building A and construct Buildings B & C. The required additional A&E Redesign services fee are being absorbed into the project cost.

Currently Unfunded Project Costs

	Original Budget	Revisions	Revised Budget	Encumbrance	Expenditures	Remaining Budget
Estimated GMP Overage:	\$ -	\$ 5,227,730	\$ 5,227,730	\$ -	\$ -	\$ 5,227,730
Estimated DESIGN Overage: Overland	\$ -	\$ 262,771	\$ 262,771	\$ -	\$ -	\$ 262,771

Capital Improvement Program - Project Summary



Estimated Hard Costs: Utilities	\$ -	\$ 200,000	\$ 200,000	\$ -	\$ -	\$ 200,000
Estimated Soft Costs: Bldg. Permit	\$ -	\$ 100,850	\$ 100,850	\$ -	\$ -	\$ 100,850
Estimated CMT - Terracon		\$ 143,488	\$ 143,488			\$ 143,488
Estimated Cx & Inspections - Terracon		\$ 41,800	\$ 41,800			\$ 41,800
Estimated FF&E Overage		\$ 1,409,650	\$ 1,409,650			\$ 1,409,650
	\$ -	\$ -	\$ -	\$ -	\$ -	\$ -
Total One-Time Budget:	\$ -	\$ 7,386,289	\$ 7,386,289	\$ -	\$ -	\$ 7,386,289
Variance from Other Revenues:	\$ -					

Budget Comments:

Approval of the Guaranteed Maximum Price (GMP) for Construction Manager-at-Risk Contract

Thomas S. Byrne D/B/A Byrne Construction Services,
Northwest Education and Training Center

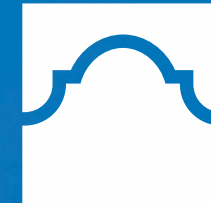

ALAMO
COLLEGES
DISTRICT

Mr. Lacy Hampton

Interim Associate Vice Chancellor
G.O. Bonds Capital Program (CIP)



Board Policies in Support of Charges

C.2.3 Facilities and Grounds Management

- Maintenance and Operations: The College District shall ensure that its facilities are safe, comfortable, and hygienic for students, faculty, employees, and the general public. Consistent maintenance standards shall be employed throughout the College District. Periodic assessments of the condition of College District facilities shall be conducted.
- Preventive Maintenance: The College District administration shall prepare, budget, and execute an annual preventive maintenance program.

Charges to the Chancellor

- General Obligation Bond
- Project Management for Capital Projects





ALAMO
COLLEGES
DISTRICT

GROUNDBREAKING FUTURES

\$87.2M

Education and Training Centers
Total Investment



\$69M Capital Investment

General Obligation bond in 2017



\$18.2M Investment to extend life of aging facilities

Maintenance Tax Notes in 2022



ALAMO
COLLEGES
DISTRICT



Northwest Education and Training Center (NWETC)

Project Statistics:

- **Architect:** Overland Partners
- **CMAR:** Thomas S. Byrne (D/B/A Byrne Construction Services)
- **Building Square Footage:** 40,530 sf
- **Classrooms:** General Classrooms, Computer Labs, Welcome Center, Student Service Center and Outside Seating/Learning



Northwest Education and Training Center (NWETC)



ALAMO
COLLEGES
DISTRICT



Northwest Education and Training Center (NWETC)

Construction GMP (Thomas S. Byrne D/B/A Byrne Construction Services)	\$	24,895,138
FF&E	\$	1,527,700
Project Soft Cost	\$	3,963,451
A/E; Eng. Services; Bldg. Permit Fees; Public Art; & Material Testing		

G.O. Bonds, Institutional Funding, and Real Estate Savings

TOTAL PROJECT COST **\$** **30,386,289**

**Refer to appendix rebalance sheet*



May 14, 2024 Minute Order Actions

- Discussion and Possible Action on Guaranteed Maximum Price for Alamo Colleges District – Northwest Education and Training Center Capital Improvement Project (CIP), Construction Manager-at-Risk Contract with Thomas S. Byrne D/B/A Byrne Construction Services. (CSP 18C-005)



Thank you.

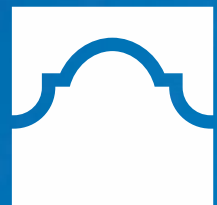

ALAMO
COLLEGES
DISTRICT



**NORTHWEST EDUCATION AND TRAINING CENTER (NWETC)
ALAMO COLLEGES DISTRICT**



**ALAMO
COLLEGES
DISTRICT**

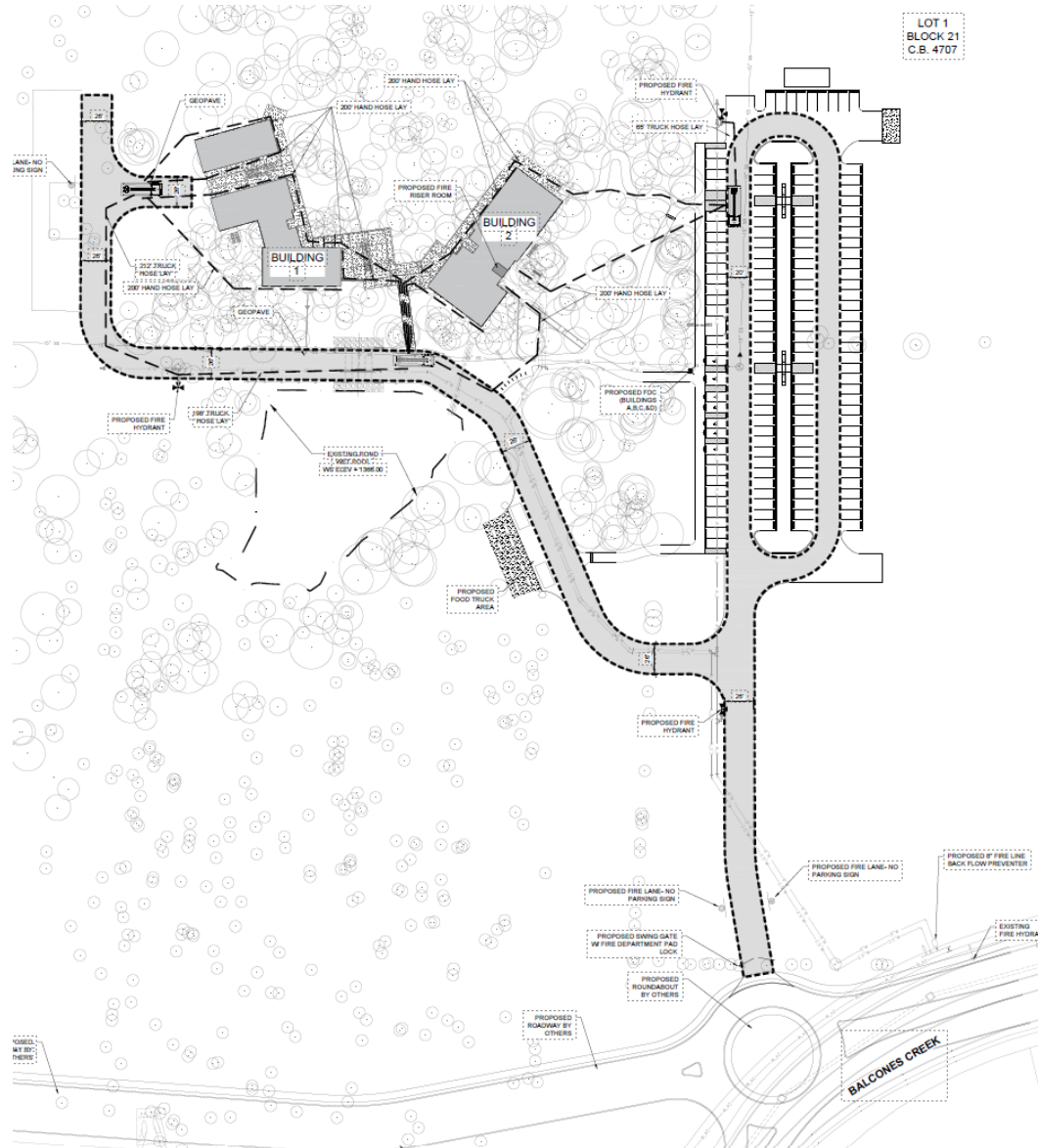

**NORTHWEST EDUCATION AND TRAINING CENTER (NWETC) SITE PLAN
TOTAL SF 40,530
29587 IH-10W (BALCONES CREEK), BOERNE, TEXAS 78006**

Capital Improvement Program - Project Summary



General Information

Location/Campus:	Higher Education Regional Centers	Bond Tranche #:	2
Project Title:	I-10 Northwest Education and Training Center	Target Completion:	Orig. 11/12/2021 Rev. 12/4/2025
Project Type:	New Building	Target Square Footage:	30,000 / 40,530
Project Manager:	Joe Martinez	Construction Manager:	Thomas S. Byrne D/B/A Byrne Const. Svcs.
Architect/Engineer:	Overland Partners	Furniture:	SKG Texas
Project Description:	The 2017 CIP project is part of the Alamo Colleges District Higher Education Regional Center / Campus network, designed to increase access to higher education services for high residents of growth sectors in Bexar County. The plan is to build the facility to meet higher education facility standards and to attain approval to offer accredited academic and workforce degree programs and courses.		

Revenue Source	Projected Costs
Gen. Oblig. Bonds	Current Estimated GMP Costs
Real Estate Savings	Current Estimated Hard Costs
Institutional Funds	Current Estimated Soft Costs:
	Current Estimated FF&E Costs:
Total Revenue:	Total Projected Costs:

GO17 Bond Funded Expenditure Budget	Original Budget	Revisions	Revised Budget	Encumbrances	Expenditures	Remaining Budget
Land Costs: Southwest Appraisal Group		\$ 4,000	\$ 4,000		\$ 4,000	\$ -
Pre-Construction: Sundt Construction		\$ 65,632	\$ 65,632		\$ 65,632	\$ -
Pre-Construction: Byrne Construction		\$ 27,090	\$ 27,090	\$ 11,120	\$ 15,970	\$ -
Construction GMP: Byrne Construction	\$ 15,333,333	\$ 4,306,985	\$ 19,640,318	\$ -	\$ -	\$ 19,640,318
Arch.: Overland	\$ 1,533,333	\$ 1,148,619	\$ 2,681,952	\$ 395,027	\$ 2,286,925	\$ -
Const. Mtrls.Testing: Terracon	\$ 306,667	\$ (257,859)	\$ 48,808		\$ 48,808	\$ -
Spclzd. Engineering Svcs: Bain Medina Bain	\$ 153,333	\$ 258,450	\$ 411,783	\$ 47,600	\$ 364,183	\$ (0)
Bldg Permit & Printing Fees: 74108	\$ 153,334	\$ (151,467)	\$ 1,867		\$ 1,867	\$ (0)
Development Fees: 74102 Protection Dvlp.		\$ 500	\$ 500		\$ 500	\$ -
Public Art:	\$ 153,333	\$ (153,333)	\$ 0	\$ -	\$ -	\$ 0
F,F&E:	\$ 5,366,667	\$ (5,248,617)	\$ 118,050	\$ 95,031		\$ 23,019
		\$ -	\$ -	\$ -	\$ -	\$ -
Total Bond Funded Budget:	\$ 23,000,000	\$ -	\$ 23,000,000	\$ 548,778	\$ 2,787,886	\$ 19,663,336
Variance from Bond Revenue:	\$ -					

Budget Comments: This project includes \$23M of GO17 Bonds plus \$7.386M of INSTL funds. The project scope changes include Redesign efforts to eliminate Building A and construct Buildings B & C. The required additional A&E Redesign services fee are being absorbed into the project cost.

Currently Unfunded Project Costs

	Original Budget	Revisions	Revised Budget	Encumbrance	Expenditures	Remaining Budget
						215
Estimated GMP Overage:	\$ -	\$ 5,227,730	\$ 5,227,730	\$ -	\$ -	\$ 5,227,730
Estimated DESIGN Overage: Overland	\$ -	\$ 262,771	\$ 262,771	\$ -	\$ -	\$ 262,771

Capital Improvement Program - Project Summary



Estimated Hard Costs: Utilities	\$ -	\$ 200,000	\$ 200,000	\$ -	\$ -	\$ 200,000
Estimated Soft Costs: Bldg. Permit	\$ -	\$ 100,850	\$ 100,850	\$ -	\$ -	\$ 100,850
Estimated CMT - Terracon		\$ 143,488	\$ 143,488			\$ 143,488
Estimated Cx & Inspections - Terracon		\$ 41,800	\$ 41,800			\$ 41,800
Estimated FF&E Overage		\$ 1,409,650	\$ 1,409,650			\$ 1,409,650
	\$ -	\$ -	\$ -	\$ -	\$ -	\$ -
Total One-Time Budget:	\$ -	\$ 7,386,289	\$ 7,386,289	\$ -	\$ -	\$ 7,386,289
Variance from Other Revenues:	\$ -					

Budget Comments:

Discussion and Possible Action on the Adoption of a Revised 217 Capital Improvement Program Project Budget for the Northwest Education and Training Center (NWETC) with Impacts of Real Estate Savings

Mr. Lacy Hampton

Interim Associate Vice Chancellor
G.O. Bonds Capital Program (CIP)

Lisa Mazure

Associate Vice Chancellor for Finance & Administration

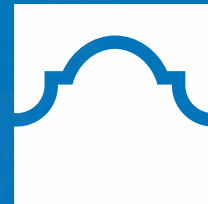

ALAMO
COLLEGES
DISTRICT



Action Requested

Approve the attached revised 2017 Capital Improvement Program project budget for Northwest Education and Training Center (NWETC) with impacts of 2017 Capital Improvement Program Real Estate savings.

Thank you.

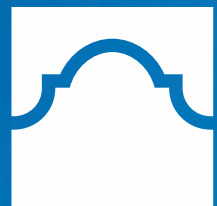

ALAMO
COLLEGES
DISTRICT



Discussion and Possible Action on the Adoption of a Revised 2017 Capital Improvement Program Project Budget for Northwest Education and Training Center (NWETC) with Impacts of Real Estate Savings

Presented to the Board Acting as Committee of the Whole on May 14, 2024 and presented to the Board for approval on May 21, 2024.

MINUTE ORDER

"The Board of Trustees hereby approves the attached revised 2017 Capital Improvement Program project budget for Northwest Education and Training Center (NWETC) with impacts of 2017 Capital Improvement Program Real Estate savings."

PURPOSE

To adjust the 2017 CIP project budget for Northwest Education and Training Center (NWETC) with impacts of savings from real estate purchases previously approved under the 2017 CIP Capital Improvement Program.

BACKGROUND

The Board directed administration to prepare a Capital Improvement Program ("CIP") project list consistent with its 2017 Debt Management Plan adopted May 17, 2016. That project list was approved on January 17, 2017 after receiving the input of Citizen's Bond Advisory Committee and was the basis for the successful Bond Election on May 6, 2017.

Revision to the CIP Project budget for Northwest Education and Training Center (NWETC) is recommended based on projected costs for projects that have not started construction and to reflect the additional funding.

IMPLICATIONS

Financial: Funding Source: General Obligation Bonds
Strategic Objective: I, II & III; Student Success, Principle-Centered Leadership and Performance Excellence
ATTACHMENTS: Revised NWETC 2017 CIP Project Budget



Dr. Thomas S. Cleary Date
Interim Vice Chancellor
for Finance & Administration

Lisa Mazure, CPA Date
Assoc. Vice Chancellor for Finance & Fiscal Svc.

Dr. Mike Flores Date
Chancellor

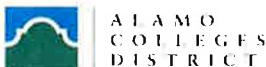

Adoption of Revised 2017 Capital Improvement Program Project Budget – Real Estate Savings

Northwest Education and Training Center (NWETC)

Mr. Lacy Hampton

Interim Associate Vice Chancellor
G.O. Bonds Capital Program (CIP)

Lisa Mazure

Associate Vice Chancellor for
Finance & Administration

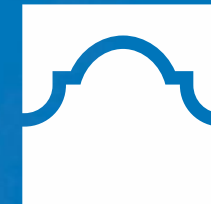

ALAMO
COLLEGES
DISTRICT



Action Requested

Approval to adjust the 2017 CIP project budget for the Northwest Education and Training Center (NWETC)

- Savings from previously approved 2017 CIP real estate purchases



May 14, 2024 Minute Order Actions

- Discussion and Possible Action on the Adoption of a Revised 2017 Capital Improvement Program Project Budget for Northwest Education and Training Center (NWETC) with Impacts of Real Estate Savings



Thank you.

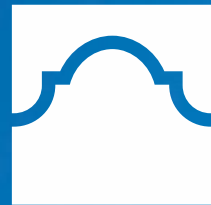

ALAMO
COLLEGES
DISTRICT



Legislative Report – Regular Board Meeting

Priscilla Camacho, Chief Legislative, Industry and External Relations Officer

May 21, 2024

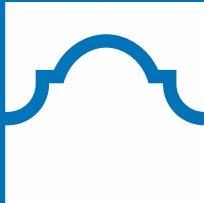

ALAMO
COLLEGES
DISTRICT





Legislative Updates

- **Federal Updates**
 - Community Project Funding
- **State Updates**
 - Interim Charges and Hearings
- **Local Updates**
 - Charter Review Commission
- **EY Partnership Highlight**



Federal Update

- **Community Project Funding (CPF):** formerly known as earmarks allow Congressional Representatives to make requests to the Appropriations Committee for funding for specific projects for state, local, or tribal governments or certain nonprofits.
- **FY24:** Within the FY24 Federal Budget **San Antonio College will receive \$1M in CPF monies for the Empowerment Center.** Request was made by Congressman Greg Casar.



You're invited to join

CONGRESSMAN GREG CASAR

to celebrate the \$1 MILLION federal investment in San Antonio College's Empowerment Center for Community and Veteran Outreach!

Thursday, May 30th at 2pm
San Antonio College's Victory Center
1819 N. Main Ave.



RSVP at bit.ly/sacempowerment

All are welcome! We'll share a few words and take a group photo with community leaders.



ALAMO
COLLEGES
DISTRICT



State Update

Interim Charges: Policy issues that both the House and Senate study during the interim before the following legislative session.

SENATE INTERIM CHARGES:

- HB8 Implementation
- Nursing Related Post-Secondary Education (SB25)
- Ban on DEI Policies (SB17)
- Tenure Legislation (SB18)
- Faculty Senates
- Antisemitism on Campus
- Campus Free Speech
- Artificial Intelligence

First Senate Interim Hearing held on May 14, 2024

HOUSE INTERIM CHARGES:

- HB8 Implementation
- Nursing Related Post-Secondary Education (SB25)
- Ban on DEI Policies (SB17)
- Tenure Legislation (SB18)
- Professional License portability for military members and spouses
- School to Workforce Pipeline /Tri-Agency Updates on incentive and performance alignment
- Property Taxes



Local Update

- **Charter Review Commission**

- Recommendations

- Removal of language with cap on tenure of city manager
 - Removal of language with cap on pay of the city manager
 - Change city council and mayoral terms from 4 two-year terms to 2 four-year terms
 - Salary for Council and Mayor to be re-baselined to \$80,000 and \$95,000 respectively
 - No expansion of City Council Districts
 - 105 sections of recommended language modernization

- Timeline

- June – Presentation to Mayor and City Council with final recommendations



EY Partnership Highlight



- Partnership in collaboration with the Business Roundtable Workforce Partnership Initiative (WPI).
- EY reassessed the credentials required for their Level Assurance positions in San Antonio as a part of its expanded Service Delivery Center
- EY worked with ACD Career Services to connect with students and faculty
- **To date EY has hired @ 100 Alamo Colleges graduates**



Thank you.

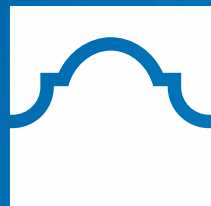

ALAMO
COLLEGES
DISTRICT



Policy H.03.01 – Executive Order GA-44

Ross Laughead, General Counsel
Dr. Daphene Carson, Director of Ethics/Compliance/Policy

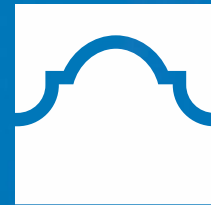

ALAMO
COLLEGES
DISTRICT



Malcolm Baldrige
National Quality Award

2018 Award Recipient



Great
Place
To
Work[®]

Certified
MAR 2024-MAR 2025
USA

Board Policy

B.5.3 – Board Policies

Purpose

The Texas Governor has issued Executive order GA-44 requiring Texas public institutions of higher education to adopt policies against antisemitic speech & acts.



Context

- Texas Education Code § 51.9315 requires the College District to allow expressive activities in the common outdoor areas of its facilities without regard for most content or viewpoint, implemented as Procedure F.9.1.1.
- The College District as a governmental unit is restricted from taking adverse action against persons exercising rights of freedom of expression guaranteed by the First Amendment of the United States Constitution.
- Executive order GA-44 requires Texas public institutions of higher education to adopt policies against antisemitic speech & acts.
- The proposed revision to Policy H.3.1 and implementing procedure revisions are designed to implement EO GA-44 as these directives may be reconciled by the legal system.

Action Requested

- To approve revised Policy H.3.1 – State Law Prohibitions.



Thank you

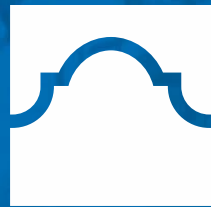

ALAMO
COLLEGES
DISTRICT



H.3.1 (Policy) State ~~Law~~Legislative Prohibitions on Diversity, Equity and Inclusion and Against Antisemitism

Responsible Departments: Alamo Colleges District Title IX/VII/IV/ADA/504 Coordinator and General Counsel

Board Adoption: 12-19-23

Purpose

This policy is designed to implement state law~~legislative~~ requirements limiting and prohibiting certain practices, including those generally referred to as Diversity, Equity and Inclusion initiatives, codified Texas Education Code §51.3525, and tolerating antisemitic speech and acts, as antisemitism is defined at Texas Government Code §Section 448.001, as required by Executive Order GA-44. In any unintended cases of failure of this policy to conform to then-applicable statutory, ~~and~~ regulatory or executive order requirements regarding such matters, those requirements are hereby incorporated by reference and shall prevail to the extent of any conflict. The Chancellor may adopt procedures which, without limitation, reflect regulations to be drafted by state agencies to implement statutory requirements.

Diversity, Equity and Inclusion Practices

Definition

Diversity, Equity and Inclusion practices are defined as:

- (1) influencing hiring or employment practices at the institution with respect to race, sex, color, or ethnicity, other than through the use of color-blind and sex-neutral hiring processes in accordance with any applicable state and federal antidiscrimination laws;
- (2) promoting differential treatment of or providing special benefits to individuals on the basis of race, color, or ethnicity;
- (3) promoting policies or procedures designed or implemented in reference to race, color, or ethnicity; or
- (4) conducting training, programs, or activities designed or implemented in reference to race, color, ethnicity, gender identity, or sexual orientation

Prohibition

The College District shall not establish or maintain a Diversity, Equity and Inclusion office, division, unit, or function, or hire or assign an employee, or contract with a third party for the purposes of conducting Diversity, Equity and Inclusion practices as outlined in the definition section of this policy.

The College District shall not compel, require, induce, or solicit any person to provide a diversity, equity and inclusion statement, or give preferential consideration (e.g., in employment) to any person based on the provision of a diversity, equity and inclusion statement.

The College District shall not give preference on the basis of race, sex, color, ethnicity or national origin to an applicant for employment, an employee, or a participant in any function of the College District.

H.3.1 (Policy) State ~~Law~~ Legislative Prohibitions on Diversity, Equity and Inclusion and Against Antisemitism

Responsible Departments: Alamo Colleges District Title IX/VII/IV/ADA/504 Coordinator and General Counsel

Board Adoption: 12-19-23

The College District shall not require any person as a condition of enrollment or of performing any institutional function to participate in training which is designed or implemented in reference to race, color, ethnicity, gender identity, or sexual orientation.

Exceptions

Policies, procedures and required training, programs and activities otherwise prohibited are allowed only when approved in writing by the institution's general counsel and the Texas Higher Education Coordinating Board for the sole purpose of ensuring compliance with any applicable court order or state or federal law.

Required training, programs and activities also must be developed by an attorney and maintained in (i) the AlamoTALENT learning management system if for employees, and (ii) the office of the Vice Chancellor for Student Success if for students.

This policy does not restrict the issuance of statements that highlight the College District's work in supporting first-generation college students, low-income students, or underserved student populations for purposes, without limitation, of grant application or accreditation maintenance.

This policy does not restrict a policy, practice, procedure, program, or activity to enhance student academic achievement or postgraduate outcomes that is designed and implemented without regard to race, sex, color, or ethnicity.

Additional exceptions are, and this policy does not restrict:

- academic course instruction;
- scholarly research or a creative work by students, faculty or other research personnel or the dissemination of that research or work;
- an activity of a registered or recognized student organization;
- guest speakers or performers on short-term engagements;
- data collection; or
- student recruitment or admissions.

Required Periodic State Reporting

The Board must submit to the Legislature and the Texas Higher Education Coordinating Board a report certifying its compliance with Texas Education Code §51.3525 during the preceding state fiscal year before spending money appropriated to the institution for a current fiscal year.

In the interim between each regular session of the Legislature, the Board's designee must testify before the standing legislative committees with primary jurisdiction over higher education at a public hearing regarding its compliance with Section 51.3525.

H.3.1 (Policy) State ~~Law~~**Legislative Prohibitions on Diversity, Equity and Inclusion and Against Antisemitism**

Responsible Departments: Alamo Colleges District Title IX/VII/IV/ADA/504 Coordinator and General Counsel

Board Adoption: 12-19-23

Institutional Consequences of Violation

The State Auditor must audit College District compliance with Texas Education Code §51.3525 at least once every four years. If the State Auditor determines that the College District has spent state money in violation of that section, the College District must cure the violation within 180 days after that determination is made to avoid ineligibility to receive formula funding increases, institutional enhancements, or exceptional items during the immediately following the state fiscal biennium.

A student or employee of the College District who is required to participate in training in violation of Texas Education Code §51.3525(b)(1)(E) may bring an action for injunctive or declaratory relief against the College District.

Antisemitism

Definition (from Texas Government Code § 448.001)

Antisemitism is defined as a certain perception of Jews that may be expressed as hatred toward Jews. The term includes rhetorical and physical acts of antisemitism directed toward Jewish or non-Jewish individuals or their property or toward Jewish community institutions and religious facilities.

Admonition

The College District shall foster appropriate discourse.

Prohibition

The College District shall not tolerate antisemitic speech or acts by employees, students, other persons or groups on its premises, including its protected free speech areas.

Discipline

Employees

- Inadvertent failure to comply with this policy shall be no more than a Step One disciplinary offense under the Progressive Discipline Procedure D.9.1.2.
- A second inadvertent failure to comply and ANY reckless failure to comply shall be a Step Two disciplinary offense.
- A third inadvertent failure to comply, a second reckless failure to comply and ANY knowing or deliberate failure to comply shall be a Step Three disciplinary offense.
- ANY violation of this policy whatsoever occurring after a Step Three violation of this policy shall be a Step Four disciplinary offense resulting in termination of employment

H.3.1 (Policy) State Law Legislative Prohibitions on Diversity, Equity and Inclusion and Against Antisemitism

Responsible Departments: Alamo Colleges District Title IX/VII/IV/ADA/504 Coordinator and General Counsel

Board Adoption: 12-19-23

for cause.

Contractors

The engagement of an independent contractor to the College District whose activities on behalf of the College District violate Texas Education Code §51.3525 is terminable at the discretion of the College District, subject to any countervailing statutory or regulatory restrictions.

Students

Students who engage in prohibited antisemitic speech or acts are subject to discipline under the student Non-Academic Misconduct Disciplinary and Appeals Process, Procedure F.4.2.1, up to and including expulsion.

Internal Reporting of Possible Violations

Suspected violations of this policy may be reported to the Director of Ethics, Compliance & Policy or through the NAVEX online reporting system.

Legal Reference -Texas Education Code §51.3525

Texas Government Code § 448.001

Executive Order GA-44

Legal Reference - TACC Policy Reference Manual

H.3.1 (Policy) State Law Prohibitions

Responsible Departments: Alamo Colleges District Title IX/VII/IV/ADA/504 Coordinator and General Counsel

Board Adoption: 12-19-23

Last Amended: 5-21-2024

Purpose

This policy is designed to implement state law requirements limiting and prohibiting certain practices, including those generally referred to as Diversity, Equity and Inclusion initiatives, codified Texas Education Code §51.3525, and tolerating antisemitic speech and acts, as antisemitism is defined at Texas Government Code § 448.001, as required by Executive Order GA-44. In any unintended cases of failure of this policy to conform to then-applicable statutory, regulatory or executive order requirements regarding such matters, those requirements are hereby incorporated by reference and shall prevail to the extent of any conflict. The Chancellor may adopt procedures which, without limitation, reflect regulations to be drafted by state agencies to implement statutory requirements.

Diversity, Equity and Inclusion Practices

Definition

Diversity, Equity and Inclusion practices are defined as:

- (1) influencing hiring or employment practices at the institution with respect to race, sex, color, or ethnicity, other than through the use of color-blind and sex-neutral hiring processes in accordance with any applicable state and federal antidiscrimination laws;
- (2) promoting differential treatment of or providing special benefits to individuals on the basis of race, color, or ethnicity;
- (3) promoting policies or procedures designed or implemented in reference to race, color, or ethnicity; or
- (4) conducting training, programs, or activities designed or implemented in reference to race, color, ethnicity, gender identity, or sexual orientation

Prohibition

The College District shall not establish or maintain a Diversity, Equity and Inclusion office, division, unit, or function, or hire or assign an employee, or contract with a third party for the purposes of conducting Diversity, Equity and Inclusion practices as outlined in the definition section of this policy.

The College District shall not compel, require, induce, or solicit any person to provide a diversity, equity and inclusion statement, or give preferential consideration (e.g., in employment) to any person based on the provision of a diversity, equity and inclusion statement.

The College District shall not give preference on the basis of race, sex, color, ethnicity or national origin to an applicant for employment, an employee, or a participant in any function of the College District.

The College District shall not require any person as a condition of enrollment or of

H.3.1 (Policy) State Law Prohibitions

Responsible Departments: Alamo Colleges District Title IX/VII/IV/ADA/504 Coordinator and General Counsel

Board Adoption: 12-19-23

Last Amended: 5-21-2024

performing any institutional function to participate in training which is designed or implemented in reference to race, color, ethnicity, gender identity, or sexual orientation.

Exceptions

Policies, procedures and required training, programs and activities otherwise prohibited are allowed only when approved in writing by the institution's general counsel and the Texas Higher Education Coordinating Board for the sole purpose of ensuring compliance with any applicable court order or state or federal law.

Required training, programs and activities also must be developed by an attorney and maintained in (i) the AlamoTALENT learning management system if for employees, and (ii) the office of the Vice Chancellor for Student Success if for students.

This policy does not restrict the issuance of statements that highlight the College District's work in supporting first-generation college students, low-income students, or underserved student populations for purposes, without limitation, of grant application or accreditation maintenance.

This policy does not restrict a policy, practice, procedure, program, or activity to enhance student academic achievement or postgraduate outcomes that is designed and implemented without regard to race, sex, color, or ethnicity.

Additional exceptions are, and this policy does not restrict:

- academic course instruction;
- scholarly research or a creative work by students, faculty or other research personnel or the dissemination of that research or work;
- an activity of a registered or recognized student organization;
- guest speakers or performers on short-term engagements;
- data collection; or
- student recruitment or admissions.

Required Periodic State Reporting

The Board must submit to the Legislature and the Texas Higher Education Coordinating Board a report certifying its compliance with Texas Education Code §51.3525 during the preceding state fiscal year before spending money appropriated to the institution for a current fiscal year.

In the interim between each regular session of the Legislature, the Board's designee must testify before the standing legislative committees with primary jurisdiction over higher education at a public hearing regarding its compliance with Section 51.3525.

H.3.1 (Policy) State Law Prohibitions

Responsible Departments: Alamo Colleges District Title IX/VII/IV/ADA/504 Coordinator and General Counsel

Board Adoption: 12-19-23

Last Amended: 5-21-2024

Institutional Consequences of Violation

The State Auditor must audit College District compliance with Texas Education Code §51.3525 at least once every four years. If the State Auditor determines that the College District has spent state money in violation of that section, the College District must cure the violation within 180 days after that determination is made to avoid ineligibility to receive formula funding increases, institutional enhancements, or exceptional items during the immediately following the state fiscal biennium.

A student or employee of the College District who is required to participate in training in violation of Texas Education Code §51.3525(b)(1)(E) may bring an action for injunctive or declaratory relief against the College District.

Antisemitism

Definition (from Texas Government Code § 448.001)

Antisemitism is defined as a certain perception of Jews that may be expressed as hatred toward Jews. The term includes rhetorical and physical acts of antisemitism directed toward Jewish or non-Jewish individuals or their property or toward Jewish community institutions and religious facilities.

Admonition

The College District shall foster appropriate discourse.

Prohibition

The College District shall not tolerate antisemitic speech or acts by employees, students, other persons or groups on its premises, including its protected free speech areas.

Discipline

Employees

- Inadvertent failure to comply with this policy shall be no more than a Step One disciplinary offense under the Progressive Discipline Procedure D.9.1.2.
- A second inadvertent failure to comply and ANY reckless failure to comply shall be a Step Two disciplinary offense.
- A third inadvertent failure to comply, a second reckless failure to comply and ANY knowing or deliberate failure to comply shall be a Step Three disciplinary offense.
- ANY violation of this policy whatsoever occurring after a Step Three violation of this policy shall be a Step Four disciplinary offense resulting in termination of employment for cause.

H.3.1 (Policy) State Law Prohibitions

Responsible Departments: Alamo Colleges District Title IX/VII/IV/ADA/504 Coordinator and General Counsel

Board Adoption: 12-19-23

Last Amended: 5-21-2024

Contractors

The engagement of an independent contractor to the College District whose activities on behalf of the College District violate Texas Education Code §51.3525 is terminable at the discretion of the College District, subject to any countervailing statutory or regulatory restrictions.

Students

Students who engage in prohibited antisemitic speech or acts are subject to discipline under the student Non-Academic Misconduct Disciplinary and Appeals Process, Procedure F.4.2.1, up to and including expulsion.

Internal Reporting of Possible Violations

Suspected violations of this policy may be reported to the Director of Ethics, Compliance & Policy or through the NAVEX online reporting system.

Legal Reference -Texas Education Code §51.3525

Texas Government Code § 448.001

Executive Order GA-44

Legal Reference - TACC Policy Reference Manual

Discussion and Possible Action on Debt Management C.3.1

Lisa Mazure, AVC for Finance and Fiscal Services
Dr. Daphene Carson. Director of Ethics/Compliance/Policy

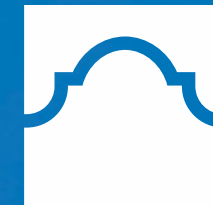

ALAMO
COLLEGES
DISTRICT



Action Requested

Approve the reviewed Alamo Colleges District Debt Management Policy C.3.1.



Thank you.

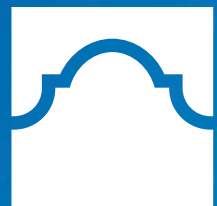

ALAMO
COLLEGES
DISTRICT



Discussion and Possible Action on Approval and Revision of Policy C.3.1

Presented to the Board Acting as Committee of the Whole on May 14, 2024 and now presented to Board for approval on May 21, 2024.

MINUTE ORDER

"The Board has reviewed the Alamo Colleges District Debt Management Policy C.3.1, and it is revised as presented in Attachment 1."

PURPOSE

Review for changes and approval.

BACKGROUND

The Board of Trustees of Alamo Colleges District adopted a Debt Management Policy in 2011. This is not a required policy, but is considered a "best practice", and it is viewed favorably by Rating Agencies. The Policy is to be reviewed and approved in conjunction with the annual Debt Management Plan.

The changes to the policy contain fixes to minor formatting errors. There are no substantive changes.

IMPLICATIONS

Financial: None

Strategic Objective: Goal III – Performance Excellence

Human Resources: None

ATTACHMENTS

Attachment 1: Current Policy C.3.1- redlined

Daphene Carson _____ May 10, 2024

Dr. Daphene Carson Date
Director Ethics/Compliance/Policy

Thomas Cleary _____ May 10, 2024

Dr. Thomas Cleary Date
Interim Vice Chancellor for Finance and
Administration

Dr. Mike Flores Date
Chancellor









Updated MO- C.3.1 Debt Management Policy

Final Audit Report

2024-05-10

Created:	2024-05-09
By:	Daphene Carson (dcarson10@alamo.edu)
Status:	Signed
Transaction ID:	CBJCHBCAABAAukDq0aD11Nhn02V5DXuXUefMd2nmFqgY

"Updated MO- C.3.1 Debt Management Policy" History

-  Document created by Daphene Carson (dcarson10@alamo.edu)
2024-05-09 - 7:17:20 PM GMT- IP address: 209.184.117.212
-  Document emailed to Dr. Thomas Cleary (tcleary1@alamo.edu) for signature
2024-05-09 - 7:17:38 PM GMT
-  Email viewed by Dr. Thomas Cleary (tcleary1@alamo.edu)
2024-05-09 - 7:28:35 PM GMT- IP address: 209.184.117.130
-  Document e-signed by Dr. Thomas Cleary (tcleary1@alamo.edu)
Signature Date: 2024-05-10 - 11:07:24 AM GMT - Time Source: server- IP address: 209.184.117.130
-  Document emailed to Daphene Carson (dcarson10@alamo.edu) for signature
2024-05-10 - 11:07:25 AM GMT
-  Email viewed by Daphene Carson (dcarson10@alamo.edu)
2024-05-10 - 11:20:48 AM GMT- IP address: 136.50.2.2
-  Document e-signed by Daphene Carson (dcarson10@alamo.edu)
Signature Date: 2024-05-10 - 11:21:10 AM GMT - Time Source: server- IP address: 136.50.2.2
-  Agreement completed.
2024-05-10 - 11:21:10 AM GMT

Policy C.3.1 – Debt Management

Lisa Mazure, AVC for Finance and Fiscal Services
Dr. Daphene Carson, Director of Ethics/Compliance/Policy

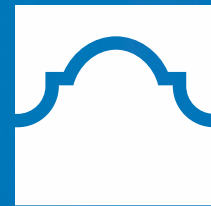

ALAMO
COLLEGES
DISTRICT



Malcolm Baldrige
National Quality Award
2018 Award Recipient



Board Policy

B.5.3 – Board Policies (Policy)

Purpose

- The Board of Trustees of Alamo Colleges District adopted a Debt Management Policy in 2011.
- Policy C.3.1 required the policy to be reviewed annually by the Board as part of the Debt Management Plan.
- The changes to the policy contain fixes to minor formatting errors. There are no substantive changes.



Action Requested

- To approve revised Policy C.3.1 Debt Management Policy



Thank you

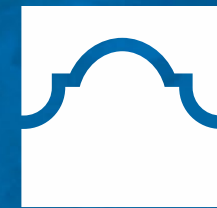

ALAMO
COLLEGES
DISTRICT



C.3.1 (Policy) Debt Management

Responsible Department: Vice Chancellor for Finance and Administration

Board Adoption: 5-17-11

Last Board Action: 5-16-23

General

This Policy (the “Policy”) establishes conditions for the use of debt and creates procedures and policies designed to manage the Alamo Community College District’s (the “College District”) obligations within available resources, minimize the debt service and issuance costs, achieve the highest credit ratings, maintain full, complete, and accurate financial disclosure and reporting, and to comply with appropriate and applicable laws of the State of Texas (the “State”) and federal law.

Scope

Within the applicable laws of the State, the College District may enter into debt obligations to finance the construction or acquisition of buildings and infrastructure and other assets, to finance maintenance of existing facilities, to purchase land and personal property, to refinance or restructure existing debt. Unless recommended otherwise by the Vice Chancellor for Finance and Administration, whose recommendation must be approved by the Board of Trustees, all debt will be incurred at the College District level or through a Public Facility Corporation created by the College District. This Policy applies to all debt issued regardless of the purpose for which issued or the funding source for repayment. The Vice Chancellor for Finance and Administration is responsible for the debt management for the College District. Responsibility for the operational activity related to management of debt may be delegated to the Associate Vice Chancellor of Finance and Fiscal Services (AVC), or Treasurer.

Objectives

The objective of the Policy is to ensure prudent debt management practices that include:

- Minimize or avoid year-to-year fluctuations in the tax rate
- Minimize borrowing costs
- Structure the earliest possible maturity of the debt
- Preserve or enhance the College District’s credit ratings
- Assure complete, and accurate financial disclosure and reporting compliance
- Comply with State and federal laws

Available Borrowing Methods

General Obligation Bonds - These bonds are issued for the acquisition of land, building construction costs, and the furnishing and equipping of buildings. The College District secures these bonds through levying, assessing and collecting ad valorem taxes sufficient to pay the principal and interest when due provided that the annual bond tax rate will never exceed the State

C.3.1 (Policy) Debt Management

Responsible Department: Vice Chancellor for Finance and Administration

Board Adoption: 5-17-11

Last Board Action: 5-16-23

statutory limit or the limits established by the College District's qualified voters. The College District's statutory maximum tax rate is established pursuant to Section 130.122, as amended, Texas Education Code at \$1.00 per \$100 of taxable assessed value (of which a maximum of \$0.50 may be utilized for debt service purposes). However, the College District's qualified voters limited the total tax rates - maintenance and operations ("M&O") and debt service- to a combined amount not to exceed \$0.25 per \$100 of taxable assessed value at an election held on September 30, 1952. General Obligation bonds require voter authorization.

Maintenance Tax Notes - The College District may issue notes that are secured by and payable from the College District's maintenance and operations tax, but may be paid from any lawfully available funds of the College District. Repayment may be made through either ad-valorem tax revenues or non-tax revenues. These Notes will be used for furnishing and equipping existing buildings, and for making renovations and repairs to existing facilities. Maintenance Tax Notes do not require voter authorization.

Revenue Bonds - The College District may issue revenue bonds for the acquisition of land, buildings, building construction costs, and the furnishing and equipping of buildings. These bonds are payable from and are secured by pledged revenues, such as tuition and other fees, a reserve fund, or other resources. Voter approval is not required. Debt service coverage ratios or other bond provisions contained in existing revenue bond covenants must be considered when issuing new revenue debt.

Lease Revenue Bonds - Under Chapter 303 of the Texas Local Government Code, the College District is authorized to establish a Public Facility Corporation ("PFC"). This corporation has the authority to issue bonds to construct facilities for the College District without an election. The College District would lease these facilities from the PFC and the PFC would use those lease revenues to pay the debt service on the bonds issued by the PFC. These bonds are payable based upon an annual appropriation from lawfully available funds, including from M&O tax revenues. The funds may be used for construction, furnishing, and equipping the new facilities. Public notice must be given prior to entering into a contract for the use or purchase or other acquisition of the improvements, which permits a petition process to require an election.

Refunding Bonds- All or any part of the College District's outstanding bond issues may be refunded or refinanced.

Other- From time to time, other financing options may be considered, including:

Contract Revenue Bonds- Capital improvements may be financed through Contract Revenue Bonds, which requires the College District to enter into a contract with a third-party entity. These bonds are payable from either taxes, revenues, or both. Voter approval is not required.

C.3.1 (Policy) Debt Management

Responsible Department: Vice Chancellor for Finance and Administration

Board Adoption: 5-17-11

Last Board Action: 5-16-23

Taxable Debt- Taxable debt may be used for all or part of a debt issue and to comply with limitations imposed by the Internal Revenue Code of 1986, as amended (the “Code”). Taxable debt may also be issued for refunding if the net present value as a percentage of the par amount of the refunded bonds is at least 5% and the refunded tax-exempt issue cannot be advance refunded on a tax-exempt basis per the Code.

Private Placements- Private placements are sold directly to investors. They can be short or medium term, fixed or floating rate, and the term will not exceed the useful life of the financed assets. Private placements may be used for financing specific assets or programs when it provides more advantageous terms than the capital markets, has a favorable structure, and financing is needed more quickly than what may be obtained through a public offering.

Alternative Structures

The College District will not use alternative financial management products such as interest rate swaps, derivative products, etc. in connection with any outstanding and newly issued bonds without the express authorization from the Board of Trustees.

Debt Management Plan

Annually, a Debt Management Plan (the “Plan”) will be presented to the Board of Trustees by the Vice Chancellor of Finance and Administration or the Associate Vice Chancellor of Finance and Fiscal Services. Developed in conjunction with the College District’s Municipal Advisor, this Plan will include information on the current debt outstanding; any previously approved but not settled financing activities, and borrowing capacity. It will include anticipated financings needs related to the Capital Improvement Program (“CIP”) or other funding needs.

When the CIP requires a debt issuance for which a market opportunity is realized, a Parameter Order with reference to a specific debt issuance will be submitted for approval, allowing the President- Board of Trustees, the Secretary- Board of Trustees, Chancellor, Vice Chancellor for Finance and Administration, or Associate Vice Chancellor of Finance and Fiscal Services to commit to certain financing decisions. The Parameter Order allows the execution of a pricing certificate evidencing final sale terms of a debt financing. The Parameter Order provides flexibility for the College District’s Administration to react when market conditions warrant. Parameter Orders will be limited as to size and scope to comply with State law and per direction by the Board of Trustees.

C.3.1 (Policy) Debt Management

Responsible Department: Vice Chancellor for Finance and Administration

Board Adoption: 5-17-11

Last Board Action: 5-16-23

Conditions for New Money Debt Issuance

The timing of borrowing will be structured to meet the needs of the College District and to minimize the effect of negative arbitrage. When the investment earnings on borrowed proceeds are below the cost of borrowing, borrowed capital may have to be increased to provide sufficient funds to pay project expenses. Since this practice increases the cost and limits the productivity of borrowed capital, the College District will seek to minimize negative arbitrage where practical.

Any external borrowing will be coordinated to the extent possible so that multiple project needs can be accommodated in a single borrowing. Under a Parameter Order for a specific new money debt, the President- Board of Trustees, Secretary- Board of Trustees, Chancellor, Vice Chancellor for Finance and Administration, or Associate Vice Chancellor of Finance and Fiscal Services may proceed with a new money debt issuance if the appropriate conditions are met as set for in the Parameter Order.

Conditions for Debt Refunding

Periodic reviews of outstanding debt will be undertaken to determine refunding opportunities. Refunding will be considered based on economic benefit, or as needed to alter covenants, restructure debt, or stabilize the tax rate. Current refundings require at least a 3% net present value savings as a percentage of the par amount of the refunded bonds to be considered. Other factors should be considered, such as reinvestment rates and impact on the structure of the escrow. The 3% threshold rate may be disregarded under a refunding done solely for business reasons, such as for restructuring purposes. The term of the refunding bonds should not exceed the term of the bonds being refunded unless the debt is being restructured. Under a Parameter Order for a refunding bond, the President- Board of Trustees, Secretary- Board of Trustees, Chancellor, Vice Chancellor for Finance and Administration, or Associate Vice Chancellor of Finance and Fiscal Services may proceed with a debt refunding if the appropriate conditions are met as set forth in the Parameter Order.

Conditions for Debt Defeasance

Debt defeasance with funds on hand or excess tax collections will be undertaken only after careful consideration of the College District's cash flow. This may be considered as part of an overall plan to manage the College District's tax rate.

C.3.1 (Policy) Debt Management

Responsible Department: Vice Chancellor for Finance and Administration

Board Adoption: 5-17-11

Last Board Action: 5-16-23

Parameters for Debt Issuance

The term of debt will typically be for 20 years or less and will not generally exceed 30 years. Debt will be issued either on a fixed or variable rate basis. The College District will normally seek to avoid the use of capitalized interest.

In general, debt should be issued with the earliest optional redemption date that is determined to be cost-effective. Typically, debt with a final maturity beyond ten years will be structured with an optional redemption in nine or ten years at par. Debt may be structured with serial or term bonds or any combination thereof.

Method of Sale

The District may sell bond/notes through either a negotiated or a competitive sale. If a negotiated sale is done, the firms in the selling syndicate will be selected from an approved underwriting pool.

Selection of Consultants

The College District will select its municipal advisor, investment banking firms, disclosure and arbitrage rebate compliance specialists through the issuance of Request For Qualifications (RFQ). It is preferable that the services for disclosure and arbitrage rebate compliance be within the scope of the municipal advisor. Bond counsel will be selected pursuant to a Request for Qualifications process as set forth in Section 1201. 027, Texas Government Code. Investment banking firms will be retained in an “underwriting pool” for a period of five years (one year plus four annual renewals) prior to a new RFQ being issued. The underwriting syndicate for each open market negotiated bond issuance will be chosen from this pool. The selection of the Senior Manager and each syndicate member will be based upon:

- Initiation and implementation of innovative financing ideas and structures in compliance with state laws
- The expertise of bankers and underwriters required for the transaction
- The underwriting capabilities as determined by excess net capital and distribution networks relative to the size of the transaction
- Performance of each syndicate member in past transactions

Each syndicate will be balanced by capitalization. The number of firms in the syndicate will be based on the size of the issue.

Compliance Reporting/Procedures

Continuing Disclosure - The College District will comply with SEC Rule 15c2-12 by filing directly or through a third-party dissemination agent with the Municipal Securities Rulemaking Board using its Electronic Municipal Market Access system annual financial statements and certain

C.3.1 (Policy) Debt Management

Responsible Department: Vice Chancellor for Finance and Administration

Board Adoption: 5-17-11

Last Board Action: 5-16-23

required financial and operating data, and material event notices.

Arbitrage Rebate Compliance - Adequate recordkeeping will be maintained to meet arbitrage rebate compliance requirements. This includes careful tracking of investment earnings on debt proceeds and remitting any excess earnings to the federal government in a timely manner. An outside compliance specialist will be retained to calculate rebate payments and ensure that the College District maintains compliance with arbitrage rules. Post Issuance Procedures are outlined in [C.3.1.1](#) and [C.3.1.2](#).

Rating Agencies

The Associate Vice Chancellor of Finance and Fiscal Services is responsible for maintaining the primary relationship and communicating with the national rating agencies. This communications effort includes providing periodic updates on the College District's general financial condition along with coordinating meetings and presentations in conjunction with debt issuances.

The College District will request a rating from at least two major rating agencies prior to the issuance of open market transactions.

Investment of Bond Proceeds

Investment of debt proceeds will comply with the Board of Trustees approved Investment Policy, State laws, and, as appropriate, the Code.

Policy Review

This Policy will be reviewed annually by the Board of Trustees as part of the Debt Management Plan and updated as needed.

References:

Texas Education Code Section 130 (130.121130.130), Section 45.108

Chapters 1201, 1207, and 1371, Texas Government Code

Local Government Code, Chapter 303

SEC Rule 15c2-12 (as amended)

SEC Rule 15Ba1-1(d) (3) (vi).

Internal Revenue Code of 1986

C.3.1 (Policy) Debt Management

Responsible Department: Vice Chancellor for Finance and Administration

Board Adoption: 5-17-11

Last Board Action: 5-16-23

Treasury Regulation section 1.141-12

Appointment of Faculty

Regular Meeting of the Board of Trustees
May 21, 2024

Linda Boyer-Owens, SPHR, SHRM-SCP

Associate Vice Chancellor for Talent, Organization,
And Strategic Innovation

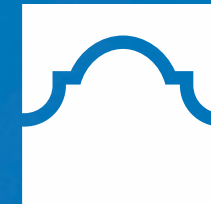

ALAMO
COLLEGES
DISTRICT



Discussion and possible Action on Appointment of Full-time Faculty

The following full-time faculty, submitted by the College Presidents for 2024-2025 academic year, are recommended to the Alamo Colleges District Board of Trustees for appointment.

Jennifer Skrhak

Mathematics & COSC
Northeast Lakeview College
Effective August 2024

Rebecca Guevara

Mathematics & COSC
Northeast Lakeview College
Effective August 2024

Miya Hunter-Willis

Social Sciences
Northeast Lakeview College
Effective August 2024

Jonathan Preiss

Natural Sciences
St. Philip's College
Effective August 2024



Discussion and possible Action on Appointment of Full-time Faculty

The following full-time faculty, submitted by the College Presidents for 2024-2025 academic year, are recommended to the Alamo Colleges District Board of Trustees for appointment.

Nicole Williams

Healthcare Sciences & Early Childhood
St. Philip's College
Effective August 2024

April Ortiz

Mathematics & Engineering
Northwest Vista College
Effective August 2024

Sarah Contreras-Orozco

Nursing Associate Degree
St. Philip's College
Effective August 2024



Thank you.

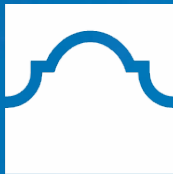

ALAMO
COLLEGES
DISTRICT



Discussion and Possible Action on Appointment of Full Time Faculty

Presented for recommended approval to the ALAMO COLLEGES BOARD OF TRUSTEES on May 21, 2024.

MINUTE ORDER

"The Board of Trustees hereby approves the appointment of Full Time Faculty submitted by the College Presidents for the 2024-2025 academic year. Further Board action will not be required for these persons to teach in the indicated disciplines."

PURPOSE

To approve the appointment of Full Time Faculty submitted by the College Presidents for the 2024-2025 Academic Year unless an earlier date is specified in Attachment A.

BACKGROUND

In serving student needs, each College maintains and selects the best and brightest faculty to provide for student success. All appointments are contingent on satisfactory completion of the employment process.

IMPLICATIONS

Financial:	Budgeted Funds
Strategic Objective:	Goal III Performance Excellence
Human Resources:	Build talent and engage employees with a focus on collaboration, application of knowledge and skills, and high performance teams

ATTACHMENTS: Attachment A.: Appointment of Faculty

Linda Boyer-Owens, SPHR, SHRM-SCP Date
Associate Vice Chancellor for Talent, Organization,
and Strategic Innovation

Dr. Mike Flores Date
Chancellor



ALAMO
COLLEGES
DISTRICT

ATTACHMENT A.



Appointment of Faculty

May 21, 2024

	<u>Recommended</u>	<u>Department</u>	<u>College</u>	<u>Effective Date</u>
1.	Skrhak, Jennifer	Mathematics & COSC	Northeast Lakeview College	August 2024
2.	Guevara, Rebecca	Mathematics & COSC	Northeast Lakeview College	August 2024
3.	Hunter-Willis, Miya	Social Sciences	Northeast Lakeview College	August 2024
4.	Preiss, Jonathan	Natural Sciences	St. Philip's College	August 2024
5.	Williams, Nicole	Healthcare Science & Early Childhood	St. Philip's College	August 2024
6.	Contreras-Orozco, Sarah	Nursing Associate Degree	St. Philip's College	August 2024
7.	Ortiz, April	Mathematics & Engineering	Northwest Vista College	August 2024

Appointment of Administrators

Regular Meeting of the Board of Trustees
May 21, 2024.

Linda Boyer-Owens, SPHR, SHRM-SCP

Associate Vice Chancellor for Talent, Organization,
and Strategic Innovation

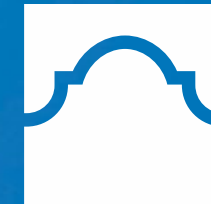

ALAMO
COLLEGES
DISTRICT



Discussion and Possible Action on Appointment of Administrators

The following individual is recommended to the Alamo Colleges District Board of Trustees for employment as Administrator.

Lisa Juarez

Interim Vice President for College
Services
Palo Alto College/Alamo Colleges
District

Dr. Shane Kendall

Interim Dean for Academic
Success/Chair/Associate Professor
St. Philip's College/Alamo Colleges
District

Jennifer Scheidt

Dean for Academic Success
Palo Alto College/Alamo Colleges
District



Thank you.

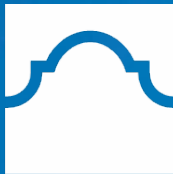

ALAMO
COLLEGES
DISTRICT



Discussion and Possible Action on Appointment of Administrators

Presented for recommended approval to the ALAMO COLLEGES BOARD OF TRUSTEES on May 21, 2024.

MINUTE ORDER

"The Board of Trustees hereby approves the recommendation of employment for the following administrator positions:

Interim Vice President for College Services
as recommended the President of Palo Alto College
and the Chancellor of the Alamo Colleges District

Dean for Academic Success
as recommended by the President of Palo Alto College
and the Chancellor of the Alamo Colleges District

Interim Dean of Academic Success/Chair/Associate Professor
as recommended by the President of St. Philip's College
and the Chancellor of the Alamo Colleges District

PURPOSE

To support the achievement of strategic Alamo Colleges District objectives.

BACKGROUND

This is approval of appointments to senior administrative positions. All appointments are contingent on satisfactory completion of the employment process.

IMPLICATIONS

Financial:	Budgeted Funds
Strategic Objective:	Goal III Performance Excellence
Human Resources:	Build talent and engage employees with a focus on collaboration, application of knowledge and skills, and high-performance teams.

ATTACHMENTS: Attachment A. Appointment of Administrators

Linda Boyer-Owens, SPHR, SHRM-SCP Date
Associate Vice Chancellor for Talent, Organization,
and Strategic Innovation

Dr. Mike Flores Date
Chancellor



ALAMO
COLLEGES
DISTRICT

Appointment of Administrators

May 2024

Lisa Juarez

Interim Vice President for College Services
as recommended by the President of Palo Alto College
and the Chancellor for the Alamo Colleges District

Jennifer Scheidt

Dean for Academic Success
as recommended by the President of Palo Alto College
and the Chancellor for the Alamo Colleges District

Dr. Shane Kendall

Interim Dean for Academic Success/Chair/Associate Professor
as recommended by the President of St. Philip's College
and the Chancellor for the Alamo Colleges District

Discussion and Possible Action on Renewal of Certain Administrative Contracts Including but not Limited to Presidents and Vice Chancellors

May 21, 2024

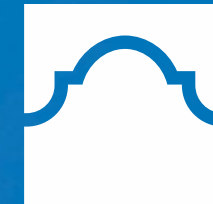

ALAMO
COLLEGES
DISTRICT

Linda Boyer-Owens, SPHR, SHRM-SCP
Associate Vice Chancellor for Talent,
Organization & Strategic Innovation



Renewal of Certain Administrative Contracts Including but not Limited to Presidents and Vice Chancellors

- In accordance with the Alamo Colleges District procedures, administrators shall be hired using contracts of one-year or two-year terms.
- Contracts of president, vice chancellors and other administrators are renewed annually.
- Contract renewals are not presented for current administrators who have already submitted notice of resignation or retirement that will occur on or before August 31, 2024.
- Contract salary amounts will be developed separately to reflect any salary adjustments approved by the Board of Trustees in the FY25 budget process.



Thank you.

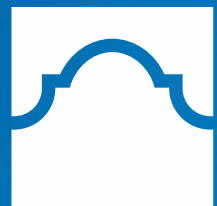

ALAMO
COLLEGES
DISTRICT



Discussion and Possible Action on Renewal of Certain Administrative Contracts Including but not Limited to Presidents and Vice Chancellors

Presented for approval to the ALAMO COLLEGES BOARD OF TRUSTEES on May 21, 2024.

MINUTE ORDER

"The Board of Trustees of the Alamo Colleges, in accordance with Policy D.2.5 adopted by the Board of Trustees, hereby authorizes the Chancellor or his designee to issue employment agreements for the administrative positions listed on Attachment A. to meet the operational needs of the College District and instructional needs of students."

All salaries are subject to the availability of funds. Approval of administrators on the attached lists does not preclude reassignment if the need for such assignment provides benefit for operations or the instructional needs of the students of the College District."

PURPOSE

To approve senior administrative positions for achievement of strategic Alamo Colleges objectives.

BACKGROUND

This is the annual renewal of administrator contracts. FY25 salary amounts will be developed separately. In accordance with the Alamo Colleges procedures, administrators shall be hired using contracts of one-year or two-year terms. Contract renewals are not presented for current administrators who have already elected to resign or retire by August 31, 2024.

IMPLICATIONS

- Financial:** Budgeted funds
- Strategic Plan:** Goal III – Performance Excellence
- Human Resources:** Build talent and engage employees with a focus on collaboration, application of knowledge and skills, and high-performance teams

ATTACHMENTS: Attachment A – Administrative Contracts for FY2025

Linda Boyer-Owens, SPHR, SHRM-SCP Date
Associate Vice Chancellor for Talent, Organization, and Strategic Innovation

Dr. Mike Flores Date
Chancellor



ALAMO
COLLEGES
DISTRICT

ATTACHMENT A.



ADMINISTRATIVE CONTRACTS

For Academic Year 2024-2025

Northeast Lakeview College

Dr. Veronica Garcia	President of the College*
Dr. Laura Boyer	Vice President for Academic Success
Dr. Tangila Dove	Vice President for Student Success
Dr. Tammy Perez	Dean for Academic Success
William Fanning	Dean for Academic Success
Dr. Jennifer Rigsby	Dean for Academic Success
Julie Kirkland-Poirier	Dean for Student Success
Georgia Flores	Dean for Student Success
Dr. Crystal Saulsberry	Executive Director AAS Nursing Program

Northwest Vista College

Dr. Amy Bosley	President of the College*
Dr. Sanjuanita Scott	Interim Vice President Student Success
Erin Sherman	Vice President for College Services
Dr. Russell Frohardt	Dean for Academic Success
Dr. Steven Montemayor	Dean for Academic Success
Jennifer Comedy-Holmes	Dean of Student Success
Robin Lund	Dean for Student Success

Palo Alto College

Dr. Robert Garza	President of the College*
Delilah Marquez	Interim Vice President for Student Success/Dean of Student Success
Patrick Lee	Vice President for Academic Success/Dean of Academic Success
Esteban Sosa	Dean for Academic Support Services
Tyler Archer	Dean for Student Success
Jennifer Flores	Interim Dean for Student Success/Dir Student Success
Caroline Haring	Dean of Performance Excellence
Rosalinda Ortiz	Chair



ADMINISTRATIVE CONTRACTS – Continued
For Academic Year 2024-2025

San Antonio College

Francisco Solis	Interim President of the College
Dr. Stella Lovato	Vice President for College Services
Dr. Cassandra Rincones	Vice President for Academic Success
Dr. Barbara Hong	Vice President for Student Success
Clare Iannelli	Dean for Academic Success
Dr. Jonathan Lee	Dean for Academic Success
Sitakanta Mohanty	Dean for Academic Success
Amy Chaye Peña	Dean of Student Success
Christina Horton	Dean for Student Success
Rosalind Ong	Interim Dean of Performance Excellence
Eve Rodriguez	Executive Director of Nursing, RN-BSN Program
Tonya Maunsell	Executive Director of Nursing, AAS Program
Kevin Conlon	Chair
Erik Hillskemper	Chair
Leonard Lira	Chair
David Wood	Chair

St. Philip's College

Dr. Adena Loston	President of the College*
Randall Dawson	Vice President for Academic Success
George Johnson	Interim Vice President College Services/Dean of Academic Success
Wesley B. Wells	Vice President for Student Success
Christopher Beardsall	Dean for Academic Success
Edith Orozco	Dean for Academic Success
Dr. Kimberly Irving-Conaway	Dean for Academic Success
Christopher Metsgar	Dean for Academic Success
Dr. Shane Kendall	Interim Dean of Academic Success/Chair/Associate Professor
Andres Arredondo	Interim Dean for Student Success
Enida Rehome	Interim Dean for Student Success
Dr. Liliana Gutierrez	Dean of Performance Excellence
Joseph Kulhanek	Chair



ADMINISTRATIVE CONTRACTS - Continued
For Academic Year 2024-2025

Vice Chancellor for Academic Success

Dr. George Railey	Vice Chancellor for Academic Success*
Dr. Lucas Dowden	Chief Online Learning Officer
Ruth Dalrymple	Associate Vice Chancellor Academic Partnerships and Initiatives
Sarah Mann	Chief High School Programs Officer

Vice Chancellor for Economic and Workforce Development

Xavier Urrutia	Interim Vice Chancellor Economic & Workforce Dev/Chief of Staff to Chancellor
Dr. Sammi Morrill	Associate Vice Chancellor Economic & Workforce Development Operations
Alejandra Bueno	Executive Director of International Programs
Stephanie Vasquez	Chief Program Officer AlamoPROMISE

Vice Chancellor for Planning, Performance, Accreditation, and Information Systems

Dr. Thomas Cleary	Vice Chancellor for Planning, Performance, Accreditation and Information Systems, and Interim Vice Chancellor Finance and Administration*
Phong Banh	District Director Information Technology Services
Kara Larkan-Skinner	District Director of Institutional Research and Effectiveness Services

Vice Chancellor for Finance and Administration

Lisa Mazure	Associate Vice Chancellor Finance & Fiscal Services
Shayne West	Associate Vice Chancellor Financial Planning & Auxiliary Services
Gregory McClure	Associate Vice Chancellor of Facilities & Construction Management
Derek Fuller	Chief of Public Safety
Patrick Vrba	Controller

Vice Chancellor for Student Success

Debi Gaitan	Interim Vice Chancellor for Student Success/Vice President Student Success NVC
Dr. Anne Monroe	Chief of Strategic Enrollment

Chancellor

George Laughead	General Counsel*
Linda Boyer-Owens	Associate Vice Chancellor for Talent, Organization, & Strategic Innovation
Kristi Wyatt	Associate Vice Chancellor Communications & Engagement
Dr. Eric Castillo	Associate Vice Chancellor Arts, Culture & Community Impact
Priscilla Camacho	Chief Legislative, Industry & External Relations Officer
Barton Simpson	Executive Director Institutional Advancement
Lacy Hampton	Interim Associate Vice Chancellor G.O. Bond CIP/Vice President College Svcs SPC

* Two-year contract

Discussion and Possible Action on Approval of the Consent Agenda Items of the Regular Board Meeting held on May 21, 2024

Recommended for Approval to the ALAMO COLLEGES DISTRICT BOARD OF TRUSTEES on May 21, 2024

MINUTE ORDER:

“The Consent Agenda for the Regular Board Meeting of the Alamo Community College District Board of Trustees held on May 21, 2024 is hereby approved.”

PURPOSE: To approve the Consent Agenda of the Regular Board Meeting on May 21, 2024

Agenda Items #20

- A.1) Approval of Minutes (a-c)
- A.2) Internal Audit Department Monthly Activity Report
- A.3) Private Gifts to the Alamo Colleges Foundation and Alamo Colleges District
- A.4) Public Safety Monthly Clery Act Activity Report
- A.5) Discussion and Possible Action on Approval of Report of Policies Reviewed with No Substantive Changes
- A.6) Fiscal Affairs Reports (a-i)

BACKGROUND: N/A

IMPLICATIONS:

Financial:	N/A
Strategic Objective:	N/A
Employee Services:	N/A

ATTACHMENT: N/A

Dr. Mike Flores, Chancellor

Discussion and Possible Action on Minutes of the Meeting of the Board of Trustees - Meeting as a Committee of the Whole on April 9, 2024

Presented and recommended for approval to the ALAMO COLLEGES BOARD OF TRUSTEES on **May 21, 2024**.

MINUTE ORDER

“The minutes of the Meeting of the Board of Trustees - Meeting as a Committee of the Whole held on April 9, 2024, are hereby approved.”

PURPOSE

To officially approve the minutes of the Meeting of the Board of Trustees - Meeting as a Committee of the Whole held on **April 9, 2024**

BACKGROUND

IMPLICATIONS

Financial: None

Strategic Objective III: Performance Excellence

Human Resources: None

ATTACHMENTS: Minutes of April 9, 2024

Dr. Mike Flores, Chancellor



**MINUTES
MEETING OF THE BOARD OF TRUSTEES
MEETING AS A COMMITTEE OF THE WHOLE
ALAMO COLLEGES DISTRICT
2222 N. ALAMO ST., SAN ANTONIO TX 78215
TUESDAY, APRIL 9, 2024**

1. CALL TO ORDER

Chair Roberto Zarate called the meeting to order at 6:00pm.

2. CERTIFICATION AND POSTING OF NOTICE

Chair Roberto Zarate announced that the notice of the Committee of the Whole Board Meeting was posted in accordance with the Texas Open Meeting Act, Texas Government Code, Chapter 551.

3. ROLL CALL

District 1: Joe Alderete, Jr.

District 2: Gloria Ray, *Assistant Secretary, Arrived at 6:19 p.m.*

District 3: Anna U. Bustamante

District 4: Dr. Lorraine Pulido, *Secretary*

District 5: Roberto Zarate, *Chair*

District 6: Dr. Gene Sprague

District 7: Dr. Yvonne Katz, *Departed at 6:55 p.m.*

District 8: Clint Kingsberry, *Vice Chair*

District 9: Leslie Sachanowicz, *Arrived at 6:19 p.m.*

Student Trustee: Brandon Aviado

Presiding Administrator: Dr. Mike Flores

Chair Roberto Zarate announced that a quorum of board members was present.

4. PLEDGE OF ALLEGIANCE

The pledge was recited.

5. CITIZENS TO BE HEARD

There were no citizens to be heard.

6. CHAIR'S REPORT - Roberto Zarate

6.A. Student Trustee Update

Brandon Aviado, Student Trustee, presented on A Year in Review, which included Vision, ACD Accomplishments & Major Collaborations, A Legacy Continued, and My Personal Journey.

Arali Garcia, Student Trustee Alternate, presented on Student Trustee Alternate Journey which included Vision, Personal Journey, Connecting with Community, and Recommendations for Success.

6.B. Community Outreach

Trustees reported their attendance at SACMEN Platica; St. Philip's College HEB Black Box Theater Groundbreaking; CIP Wrap Up; Northwest Vista College Eclipse Event; After-School All Stars; State of the City Address

7. CHANCELLOR'S REPORT - Dr. Mike Flores**7.A. Executive Faculty Council**

Dr. Steven Rodriguez, Faculty Fellow, presented an Executive Faculty Council Report which included Update of EFC Actions, Faculty Evaluation Platform (Current Status), Faculty Evaluation Platform (Future Improvement), and EFC Faculty Fellow Succession (Planned Actions).

8. ELECTIONS**8.A. Discussion and Possible Action to Approve an Order Approving Election Services Contract With Bexar County, Joint Election Agreement With Local Political Subdivisions, Early Voting And Election Day Voting Sites, And Other Matters In Connection With The May 4, 2024 Election**

Roxella Cavazos, Associate General Counsel, presented on Trustee Election-May 4, 2024 which included the Approval Requested of Ordering Approving (i) Election Services Contract with Bexar County, (ii) Joint Election Agreement with Local Political Subdivisions, (iii) Early Voting and Election Day Voting Sites, and (iv) Other Matters in Connection with the May 4, 2024 Election.

The following minute order was forwarded to the Board of Trustees for approval on April 16, 2024.

"The Board hereby approves the attached Order Approving (i) Election Services Contract with Bexar County, (ii) Joint Election Agreement With Local Political Subdivisions, (iii) Early Voting and Election Day Voting Sites, And (iv) Other Matters In Connection With The May 4, 2024 Election."

9. STUDENT SUCCESS COMMITTEE, Anna U. Bustamante, Chair**9.A. San Antonio College Four Disciplines of Execution (4DX) Report & Wildly Important Goal Presentation**

Chief Rolando Barrientez and Chief Frank L. Poyner presented on SAC First Responders Academy Fall 2023 4DX WIG which included 4DX Overview: Talent Build & Sustaining Results, Fall 2023 WIG and Lead, HOW Did We Achieve This WIG, Strategies/Outreach Efforts, SAC Resources Made Known to Students and What We Learned On Our Path To Success.

9.B. High School Programs - Alamo Academies Update

Sara Mann, Chief High School Programs Officer presented on Alamo Academies, which included ACD High School Programs, ACD Academies 2023 Summer Internships, Alamo Academies Partnerships, New Program Initiatives, and Program Development.

10. WORKFORCE DEVELOPMENT COMMITTEE, Dr. Gene Sprague, Chair**10.A. Workforce Development Committee Report**

Xavier Urrutia Interim Vice Chancellor of Economic and Workforce Development, presented on Alamo Colleges District Workforce Committee Report which included Partner Updates.

10.B. Regional Centers Update

Dr. Sammi Morrill, Associate Vice Chancellor of Operations Economic and Workforce Development presented on Expanding ACCESS & Opportunity, and Economic and Workforce Development.

11. **AUDIT, BUDGET AND FINANCE COMMITTEE**, *Dr. Yvonne Katz, Chair*

11.A. Small, Minority, Women & Veteran Owned Business Enterprise (SMWVBE) Program Update

Torence Henderson, SMWVBE Contracting Coordinator, presented on Small, Minority, Women & Veteran Owned Business Enterprise Program Update which included SMWVBE Program Objectives, Fiscal Year 2023 SMWVBE Breakdown, and SMWVBE Program – Increase Awareness, Access & Involvement.

11.B. Discussion and Possible Action on Amending the Contract for On-Site Mailroom Services

Shayne West, Associate Vice Chancellor of Financial Planning & Auxiliary Services, presented on Contract Amendment for On-Site Mailroom Services which included Amend a Contract – On-Site Mailroom Services and Recommended Contract Action.

The following minute order was forwarded to the Board of Trustees for approval on April 16, 2024.

“The Board of Trustees hereby approves amending the contract for On-Site Mailroom Services with FEJICO, LLC providing for a renewal under the same terms and conditions for approximately \$343,595 for fiscal year 2026 and decrease each year by \$7,000, including a revenue share to Alamo Colleges at 6% of the adjusted gross on retail sales; and providing for the fees necessary to relocate the DSO store as requested by the Associate Vice Chancellor for Financial Planning and Auxiliary Services.”

11.C. Discussion and Possible Action on Engagement of Independent Audit Firm for FY24

Patrick Vrba, Controller, presented on Engagement of Independent Audit Firm for FY24 Audits and FY24 Reviews which included the Purpose and Actions Requested by Board.

The following minute order was forwarded to the Board of Trustees for approval on April 16, 2024.

“The Board of Trustees authorizes execution of a one-year engagement letter, which is the second year engagement under a five-year contract with Clifton Larson Allen, LLP., providing for the purchase of independent financial audit services for the Alamo Colleges District and Northeast Lakeview College for Fiscal Year 2024 in an amount not to exceed \$329,996 (\$145,199 or 44.0% covers required Federal and State Single Audits); and the Board authorizes execution of a one-year engagement letter with Clifton Larson Allen, LLP. to provide independent financial review services for San Antonio College, St. Philip’s College, Palo Alto College, and Northwest Vista College for Fiscal Year 2024 in an amount not to exceed \$44,152 as requested by the office of the Associate Vice Chancellor for Finance and Fiscal Services.”

11.D. Discussion and Possible Action on Amending the Contract for Comprehensive Electronic Payment Services

Lisa Mazure, Associate Vice Chancellor of Finance and Fiscal Services presented on Contract Amendment for Comprehensive Electronic Payment Services which included to Amend a Contract and Recommended Contract Action.

The following minute order was forwarded to the Board of Trustees for approval on April 16, 2024.

"The Board of Trustees hereby approves amending the contract for Comprehensive Electronic Payment Services with TouchNet Information Systems, Inc. providing for a renewal under the same terms and conditions in the estimated annual amount of \$357,799, as requested by the Associate Vice Chancellor for Finance & Fiscal Services".

11.E. Discussion and Possible Action on Ratification of Award to Financial Aid Services, LLC for the Purchase of Financial Aid Counselors.

Harold Whitis, District Director of Student Financial Aid, presented on Discussion and Possible Action on Ratification of Award to Financial Aid Services. This included Need for Interim Staffing, Meeting the Staffing Needs, Action Requested, and Impact.

The following minute order was forwarded to the Board of Trustees for approval on April 16, 2024.

"The Board of Trustees hereby approves increasing the authorized spend amount under the contract with Financial Aid Services, LLC for the purchase of Financial Aid Services and ratifying a contract amendment in the amount of \$185,000 for a new amount of \$384,000, as requested by the Interim Vice Chancellor for Finance and Administration."

12. **BUILDING, GROUNDS AND SITES SELECTION COMMITTEE**, Gloria Ray, Chair

12.A. Discussion and Possible Action on the Purchase of Construction Services for Alamo Colleges District, ACCESS Building Welcome Center Conversion

Greg McClure, AVC of Facilities Operations & Construction Management, presented on the Approval of Cooperative Award for Alamo Colleges District Welcome Center which included the Purpose, Current Floor Plan, Proposed Floor Plan, and Recommended Contract Action.

The following minute order was forwarded to the Board of Trustees for approval on April 16, 2024.

"The Board of Trustees hereby approves award of a Job Order Contract to Sullivan Contracting Services providing for the purchase of construction services for Alamo Colleges to renovate space to create a new Welcome Center for a cost of \$880,632.56 plus 10% contingency, as requested by the Office of the Vice Chancellor for Finance and Administration."

- 12.B. Discussion and Possible Action for the Purchase of Construction Services for a Veteran Center for Alamo Colleges District - Northeast Lakeview College
Greg McClure, AVC of Facilities Operations & Construction Management, presented on Discussion and possible action to approve contract award for Alamo Colleges District – Northeast Lakeview College to construct a new Veterans Centers. This included Building Site Location, Purpose, Internal Financing – ACCD Revolving Capital Fund, Recommended Contract Award and Minute Order Action.

The following minute order was forwarded to the Board of Trustees for approval on April 16, 2024.

"The Board of Trustees hereby awards a contract providing for the purchase of construction services for a Veteran's Center at Alamo Colleges District – Northeast Lakeview College to Structure Tone Southwest for the amount of \$10,277,000 as requested by the Associate Vice Chancellor for Facilities Operations and Construction Management. The Board also authorizes an internal loan of up to \$2,500,000 from the revolving capital project fund as one of the funding sources for the Northeast Lakeview College Veterans Center."

- 12.C. Discussion and Possible Action to Approve Three Guaranteed Maximum Prices and Associated Construction Manager at Risk Contracts for Alamo Colleges District - Maintenance Tax Note 2022-Funded Projects for San Antonio College

Greg McClure, Associate Vice Chancellor of Facilities & Construction Management, presented on Groundbreaking Futures, Project Scope, and April 2024 Board Action.

The following minute order was forwarded to the Board of Trustees for approval on April 16, 2024.

"The Board of Trustees hereby approves the following Guaranteed Maximum Prices (GMPs) and associated Construction Manager at Risk (CMAR) contract awards, subject to subsequent execution of agreements in form acceptable to District Counsel, as requested by the Associate Vice Chancellor for Facilities Operations and Construction Management.

- *GMP with Turner Construction in the amount of \$35,005,248 for San Antonio College's Maintenance Tax Note and institutional (Preventive Maintenance) funded Contract Package 1; full facility renovation for Chance Academic Center.*

- *GMP with Turner Construction in the amount of \$13,204,656 for San Antonio College's Maintenance Tax Note institutional (Preventive Maintenance) funded Contract Package 4; full facility renovation for Nail Technical Center.*

- *GMP with Byrne Construction Services in the amount of \$3,421,719 for San Antonio College's Maintenance Tax Note institutional (Preventive Maintenance) funded Contract Package 7; major systems (HVAC) renovation for Candler Physical Education Center and Longwith Radio, Television and Film.*

13. CONSENT AGENDA REPORTS**13.A. Discussion and Possible Action on Monthly Contracts Report**

The following minute order was forwarded to the Board of Trustees for approval on April 16, 2024.

“The Alamo Colleges District Board of Trustees hereby approves this report on non-grant contracts (public) made to the Alamo Colleges District for the period of September 1, 2023, through March 31, 2024.”

13.B. Discussion and Possible Action on Monthly Grants and Contracts Report

The following minute order was forwarded to the Board of Trustees for approval on April 16, 2024.

“The Alamo Colleges District Board of Trustees hereby approves this report on grants and contracts (public) and ratifies acceptance of the donations and grants made to the Alamo Colleges District.”

13.C. Discussion and Possible Action on Approval of Construction Reports

The following minute order was forwarded to the Board of Trustees for approval on April 16, 2024.

“The Alamo Colleges District Board of Trustees hereby approves the construction reports as presented.”

13.D. Capital Improvement Program (CIP) Executive Summary

The Capital improvement Program (CIP) Executive Summary was submitted for review.

13.E. Discussion and Possible Action on Approval of Financial Reports

The following minute order was forwarded to the Board of Trustees for approval on April 16, 2024.

“The Alamo Colleges Board of Trustees hereby accepts the financial reports as presented.”

13.F. Discussion and Possible Action on Approval of Monthly Report on Cooperative Purchases in Excess of \$200,000

The following minute order was forwarded to the Board of Trustees for approval on April 16, 2024.

“The Alamo Colleges District Board of Trustees hereby approves the monthly Cooperative Purchase Report as presented.”

13.G. Discussion and Possible Action on Quarterly Investment Report Through February 29, 2024

The following minute order was forwarded to the Board of Trustees for approval on April 16, 2024.

“The Alamo Colleges District Board of Trustees hereby accepts the Investment Report as presented.”

289

14. EXECUTIVE SESSION**No Executive Session**

14.J. **RECONVENE OPEN MEETING**

No Executive Session

15. **ADJOURNMENT**

There being no further business, Chair Roberto Zarate adjourned the meeting at 9:02 p.m.

Andria J Bernal

Andria Bernal
District Projects Coordinator

Discussion and Possible Action on Minutes of the Regular Board Meeting on April 16, 2024

Presented and recommended for approval to the ALAMO COLLEGES DISTRICT BOARD OF TRUSTEES on May 21, 2024.

MINUTE ORDER

“The minutes of the Special Board Meeting of the Board of Trustees of the Alamo Community College District held on April 16, 2024 are hereby approved.”

PURPOSE

To officially approve the minutes of the Regular Board Meeting on April 16, 2024

IMPLICATIONS

Financial: None

Strategic Objective III: Performance Excellence

Human Resources: None

ATTACHMENT: Minutes of Regular Board Meeting on April 16, 2024

Dr. Mike Flores, Chancellor





**MINUTES
MEETING OF THE REGULAR BOARD OF TRUSTEES
MEETING AS A REGULAR BOARD MEETING
ALAMO COLLEGES DISTRICT
2222 N. ALAMO ST., SAN ANTONIO TX 78215
TUESDAY, APRIL 16, 2024**

1. CALL TO ORDER

Chair Roberto Zarate called the meeting to order at 6:00pm.

2. CERTIFICATION AND POSTING

Chair Roberto Zarate announced that the notice of the Regular Board Meeting was posted on accordance with the Texas Open Meeting Act, Texas Government Code, Chapter 551.

3. ROLL CALL

- District 1: Joe Alderete
- District 2: Gloria Ray, Asst. Secretary
- District 3: Anna U. Bustamante, *Arrived at 6:02 p.m.*
- District 5: Roberto Zarate, Chair
- District 6: Dr. Gene Sprague
- District 7: Dr. Yvonne Katz
- District 8: Clint Kingsberry, Vice Chair, *Arrived at 6:22 p.m.*
- Student Trustee: Brandon Aviado

Presiding Administrator: Dr. Mike Flores, Chancellor

The following trustees were not present.

- District 4: Dr. Lorraine Pulido, Secretary
- District 9: Leslie Sachanowicz

4. PLEDGE OF ALLEGIANCE

The pledge was recited.

5. INVOCATION - Dr. Lillian Porter, Director High School Programs, San Antonio College

6. MEMORIALS

Employee Memorials	Student Memorials
<p>Miguel Saucedo HVAC Mechanic Journeyman, SAC Employed: 9/14/2023 to 3/28/2024 Departed: March 28, 2024</p>	<p>Cedric “Cedie” Chavarria Student, Palo Alto College Born: February 14, 2002 Departed: March 25, 2024</p>

7. RECOGNITIONS

7.A. AlamoPROMISE Student of the Month - *Ivan Orellana*, San Antonio College

Dr. Francisco Solis, Interim President of San Antonio College, presented the Alamo Promise student of the Month Award to Ivan Orellana.

7.B. Alamo Colleges District Employee of the Month - *Armando Sanchez*, Northwest Vista College

Dr. Amy Bosley, President of Northwest Vista College, presented the Alamo Colleges District Employee of the Month Award to Armando Sanchez.

8. **CITIZENS TO BE HEARD**

8.A. There were no citizens to be heard.

9. **CHAIR'S REPORT - Roberto Zarate**

9.A. Community Outreach

The Chair reported Trustees attendance at Fiesta celebrations

The Chair reported the Teamability Two-Step Gala Recognizing Dr. Yvonne Katz

The Chair reported the recognition of Dr. Pulido as a 2024 Del Oro Community Service Award Winner

9.B. A brief video recognizing the near completion and values of the 2017 Capital Improvement Program was played

10. **ELECTIONS**

10.A. Discussion and Possible Action to Approve an Order Approving Election Services Contract With Bexar County, Joint Election Agreement With Local Political Subdivisions, Early Voting And Election Day Voting Sites, And Other Matters In Connection With The May 4, 2024 Election

On a motion by Trustee Joe Alderete, seconded by Trustee Dr. Yvonne Katz and by unanimous vote of the Board of Trustees, the following minute order was approved:

“The Board hereby approves the attached Order Approving (i) Election Services Contract with Bexar County, (ii) Joint Election Agreement With Local Political Subdivisions, (iii) Early Voting and Election Day Voting Sites, And (iv) Other Matters In Connection With The May 4, 2024 Election.”

11. **AUDIT, BUDGET AND FINANCE COMMITTEE, Dr. Yvonne Katz, Chair**

11.A. Discussion and Possible Action on Amending the Contract for On-Site Mailroom Services

On a motion by Trustee Dr. Yvonne Katz, seconded by Trustee Joe Alderete and by unanimous vote of the Board of Trustees, the following minute order was approved:

“The Board of Trustees hereby approves amending the contract for On-Site Mailroom Services with FEJICO, LLC providing for a renewal under the same terms and conditions for approximately \$343,595 for fiscal year 2026 and decrease each year by \$7,000, including a revenue share to Alamo Colleges at 6% of the adjusted gross on retail sales; and providing for the fees necessary to relocate the DSO store as requested by the Associate Vice Chancellor for Financial Planning and Auxiliary Services”.

11.B. Discussion and Possible Action on Engagement of Independent Audit Firm for FY24

On a motion by Trustee Dr. Yvonne Katz, seconded by Trustee Dr. Gene Sprague and by unanimous vote of the Board of Trustees, the following minute order was approved:

“The Board of Trustees authorizes execution of a one-year engagement letter, which is the second year engagement under a five-year contract with Clifton Larson Allen, LLP., providing for the purchase of independent financial audit services for the Alamo Colleges District and Northeast Lakeview College for Fiscal Year 2024 in an amount not to exceed \$329,996 (\$145,199 or 44.0% covers required Federal and State Single Audits); and the Board authorizes execution of a one-year engagement letter with Clifton Larson Allen, LLP. to provide independent financial review services for San Antonio College, St. Philip’s College, Palo Alto College, and Northwest Vista College for Fiscal Year 2024 in an amount not to exceed \$44,152 as requested by the office of the Associate Vice Chancellor for Finance and Fiscal Services.”

11.C. Discussion and Possible Action on Amending the Contract for Comprehensive Electronic Payment Services

On a motion by Trustee Dr. Yvonne Katz, seconded by Trustee Dr. Gene Sprague and by unanimous vote of the Board of Trustees, the following minute order was approved:

“The Board of Trustees hereby approves amending the contract for Comprehensive Electronic Payment Services with TouchNet Information Systems, Inc. providing for a renewal under the same terms and conditions in the estimated annual amount of \$357,799, on terms acceptable to District counsel, and delegates authority for renewals thereafter to the Chancellor or his designee, as requested by the Associate Vice Chancellor for Finance & Fiscal Services”.

11.D. Discussion and Possible Action on Ratification of Award to Financial Aid Services, LLC for the Purchase of Financial Aid Counselors.

On a motion by Trustee Dr. Yvonne Katz, seconded by Trustee Joe Alderete and by unanimous vote of the Board of Trustees, the following minute order was approved:

“The Board of Trustees hereby approves increasing the authorized spend amount under the contract with Financial Aid Services, LLC for the purchase of Financial Aid Services and ratifying a contract amendment in the amount of \$185,000 for a new amount of \$384,000, as requested by the Interim Vice Chancellor for Finance and Administration.”

12. BUILDING, GROUNDS & SITES SELECTION COMMITTEE, Gloria Ray, Chair

12.A. Discussion and Possible Action on the Purchase of Construction Services for Alamo Colleges District, ACCESS Building Welcome Center Conversion

On a motion by Trustee Gloria Ray, seconded by Trustee Joe Alderete and by unanimous vote of the Board of Trustees, the following minute order was approved:

"The Board of Trustees hereby approves award of a Job Order Contract to Sullivan Contracting Services providing for the purchase of construction services for Alamo Colleges to renovate space to create a new Welcome Center for a cost of \$880,632.56 plus 10% contingency, as requested by the Office of the Vice Chancellor for Finance and Administration."

12.B. Discussion and Possible Action for the Purchase of Construction Services for a Veteran Center for Alamo Colleges District - Northeast Lakeview College

On a motion by Trustee Gloria Ray, seconded by Trustee Joe Alderete and by unanimous vote of the Board of Trustees, the following minute order was approved:

"The Board of Trustees hereby awards a contract providing for the purchase of construction services for a Veteran's Center at Alamo Colleges District – Northeast Lakeview College to Structure Tone Southwest for the amount of \$10,277,000 as requested by the Associate Vice Chancellor for Facilities Operations and Construction Management. The Board also authorizes an internal loan of up to \$2,500,000 from the revolving capital project fund as one of the funding sources for the Northeast Lakeview College Veterans Center."

12.C. Discussion and Possible Action to Approve Three Guaranteed Maximum Prices and Associated Construction Manager at Risk Contracts for Alamo Colleges District - Maintenance Tax Note 2022-Funded Projects for San Antonio College

On a motion by Trustee Gloria Ray, seconded by Trustee Dr. Gene Sprague and by unanimous vote of the Board of Trustees, the following minute order was approved:

"The Board of Trustees hereby approves the following Guaranteed Maximum Prices (GMPs) and associated Construction Manager at Risk (CMAR) contract awards, subject to subsequent execution of agreements in form acceptable to District Counsel, as requested by the Associate Vice Chancellor for Facilities Operations and Construction Management.

- *GMP with Turner Construction in the amount of \$35,005,248 for San Antonio College's Maintenance Tax Note and institutional (Preventive Maintenance) funded Contract Package 1; full facility renovation for Chance Academic Center.*

- *GMP with Turner Construction in the amount of \$13,204,656 for San Antonio College's Maintenance Tax Note institutional (Preventive Maintenance) funded funded Contract Package 4; full facility renovation for Nail Technical Center.*

- *GMP with Byrne Construction Services in the amount of \$3,421,719 for San Antonio College's Maintenance Tax Note institutional (Preventive Maintenance) funded funded Contract Package 7; major systems (HVAC) renovation for Candler Physical Education Center and Longwith Radio, Television and Film.*

13. PERSONNEL

13.A. Discussion and Possible Action on Award of Annually Renewed 3-Year Faculty Contract Status Effective Fall 2024

Linda Boyer-Owens, AVC for Talent, Organization, and Strategic Innovation, presented on the Discussion and Possible Action on Award of Annually Renewed 3-year Faculty Contract Status. Which included the Overview: faculty Multi-Year Contracts, Recommended Faculty 3-Year Contracts, One-time FY25 Cost, Path to Multi-Year Contracts, 3-Year Contract Distribution, and Faculty Contract Types.

13.B. Discussion and Possible Action on Promotion in Academic Rank

Linda Boyer-Owens, AVC for Talent, Organization, and Strategic Innovation, presented on Faculty Promotions in Academic Rank.

On a motion by Trustee Dr. Gene Sprague, seconded by Trustee Joe Alderete and by unanimous vote of the Board of Trustees, the following minute order was approved:

"The Board of Trustees of the Alamo Colleges District, in accordance with policies for promotion in rank adopted by the Board of Trustees, hereby authorizes the granting of promotion in academic rank to the following faculty members as set forth on the attached lists effective Fall 2024."

13.C. Discussion and Possible Action on Reappointment of Full-time Faculty

Linda Boyer-Owens, AVC of Talent, Organization, and Strategic Innovation, presented on the Discussion and Possible Action on Reappointment of Full-time Faculty.

On a motion by Dr. Yvonne Katz, seconded by Trustee Joe Alderete and by unanimous vote of the Board of Trustees, the following minute order was approved:

“For the 2024-2025 academic year, the Board of Trustees hereby approves the attached recommendations of the College Presidents for reappointment of faculty members, who have met the full-time faculty status criteria. The Board hereby authorizes the Chancellor, or his designee, to issue faculty contracts, for a period of nine (9) months, or twelve (12) months to full-time faculty and faculty chairs, within the fiscal means of the College District and to satisfy the instructional needs of the students. The Chancellor is also authorized to issue summer employment agreements required to meet the instructional needs of the students and within the fiscal means of the College District.

All salaries are subject to the availability of funds. Approval of faculty on the attached lists does not preclude cross-college assignment of faculty, if the need for such assignment provides benefit for the instructional needs of the students of the College District.”

13.D. Discussion and Possible Action on Appointment of Administrators

Linda Boyer-Owens, AVC of Talent, Organization, and Strategic Innovation, presented on the Discussion and Possible Action on Appointment of Administrators

On a motion by Dr. Yvonne Katz, seconded by Trustee Joe Alderete and by unanimous vote of the Board of Trustees, the following minute order was approved:

“The Board of Trustees hereby approves the recommendation of employment for the following administrator positions:

Donna Wallis Executive Director AAS Nursing Program

as recommended the President of Palo Alto College and the Chancellor of the Alamo Colleges District

Diane Wilson Executive Director of Dental Hygiene Program

as recommended by the President of Palo Alto College and the Chancellor of the Alamo Colleges District

14. CONSENT AGENDA

14.A. Discussion and Possible Action on Consent Agenda Items

On a motion by Trustee Dr. Yvonne Katz, seconded by Trustee Joe Alderete and by unanimous vote of the Board of Trustees, the following minute order was approved:

“The Consent Agenda for the Regular Board Meeting of the Alamo Community College District Board of Trustees held on April 19, 2024 is hereby approved.”

14.A.1) Approval of Board Meeting Minutes

- 14.A.1)a. Discussion and Possible Action on Approval of Minutes of the Meeting of the Board of Trustees - Meeting as a Committee of the Whole on March 19, 2024

"The minutes of the Meeting of the Board of Trustees - Meeting as a Committee of the Whole held on March 9, 2024 are hereby approved."

- 14.A.1)b. Discussion and Possible Action on Minutes of the Regular Board Meeting on March 26, 2024

"The minutes of the Special Board Meeting of the Board of Trustees of the Alamo Community College District held on March 26, 2024, are hereby approved."

- 14.A.2) Internal Audit Department Monthly Activity Report

This report provides information on internal audit activities, current projects' statuses, and accomplishments related to the Alamo Colleges' Strategic Objectives of Student Success, Principle-Centered Leadership, and Performance Excellence.

- 14.A.3) Discussion and Possible Action on Acceptance of Private Gifts to the Alamo Colleges Foundation and Alamo Colleges District

"The Board of Trustees hereby accepts this gift receipt report on the Monthly Financial Statement on private gifts made in February 2024 and In-Kind Donations."

- 14.A.4) Department of Public Safety Monthly Clery Act Activity Report

The Department of Public Safety Monthly Clery Act Activity Report was reviewed.

- 14.A.5) Fiscal Services Reports

- 14.A.5)a. Discussion and Possible Action on Monthly Contracts Report

"The Alamo Colleges District Board of Trustees hereby approves this report on non-grant contracts (public) made to the Alamo Colleges District for the period of September 1, 2023, through March 31, 2024."

- 14.A.5)b. Discussion and Possible Action on Monthly Grants and Contracts Report

"The Alamo Colleges District Board of Trustees hereby approves this report on grants and contracts (public) and ratifies acceptance of the donations and grants made to the Alamo Colleges District."

- 14.A.5)c. Discussion and Possible Action on Approval of Construction Reports

"The Alamo Colleges District Board of Trustees hereby approves the construction reports as presented."

- 14.A.5)d. Capital Improvement Program (CIP) Executive Summary

The Capital Improvement Program (CIP) Executive Summary was presented.

14.A.5)e. Discussion and Possible Action on Approval of Financial Reports

“The Alamo Colleges Board of Trustees hereby accepts the financial reports as presented.”

14.A.5)f. Discussion and Possible Action on Approval of Monthly Report on Cooperative Purchases in Excess of \$200,000

“The Alamo Colleges District Board of Trustees hereby approves the monthly Cooperative Purchase Report as presented.”

14.A.5)g. Discussion and Possible Action on Quarterly Investment Report Through February 29, 2024

“The Alamo Colleges District Board of Trustees hereby accepts the Investment Report as presented.”

15. EXECUTIVE SESSION**Entered Executive Session at 6:34 p.m.**

15.A. The Board may go into Executive Session to deliberate on any item referenced in this agenda for open session or executive session based on the following potential exceptions under the Act.

15.B. Pursuant to §551.071, Texas Government Code, the Board may consult with its attorney(s) to seek their advice on any matter(s) in which the duty of the attorney(s) to the governmental body under the Texas Disciplinary Rules of Professional Conduct of the State Bar of Texas clearly conflicts with this chapter.

15.C. Pursuant to §551.071, Texas Government Code, the Board may consult with its attorneys about pending and threatened litigations.

15.D. Pursuant to §551.074, Texas Government Code, the Board may consult with its attorneys about pending EEOC charges.

15.E. Pursuant to §551.072, Texas Government Code, the Board may deliberate the purchase, exchange, lease or value of real property.

15.F. Pursuant to §551.073, Texas Government Code, the Board may deliberate regarding a negotiated contract for prospective gift or donation.

15.G. Pursuant to §551.074, Texas Government Code, the Board may deliberate the appointment, employment, evaluation, reassignment, duties, performance of duties, discipline, or dismissal of a public officer or employee(s), including, without limitation, the Chancellor.

15.H. Any action on these matters will be taken in Open Session.

16. RECONVENE OPEN MEETING**Reconvened open meeting at 6:48 p.m.**

16.A. Discussion and Possible Action on Items Discussed in Executive Session.

17. SETTING OF NEXT MEETING DATE

17.A. Regular Meeting of the Alamo Colleges Board of Trustees is scheduled for May 21, 2024.

18. ADJOURNMENT

There being no further business Chair Roberto Zarate adjourned the meeting at 6:49 p.m.

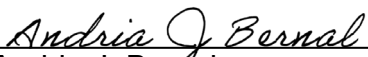
Andria J. Bernal
Districts Project Coordinator

Discussion and Possible Action on Minutes of the Special Board Meeting on April 23, 2024

Presented and recommended for approval to the ALAMO COLLEGES DISTRICT BOARD OF TRUSTEES on May 21, 2024

MINUTE ORDER

“The minutes of the Special Board Meeting of the Board of Trustees of the Alamo Community College District held on April 23, 2024 are hereby approved.”

PURPOSE

To officially approve the minutes of the Special Board Meeting on April 23, 2024

IMPLICATIONS

Financial: None

Strategic Objective III: Performance Excellence

Human Resources: None

ATTACHMENT: Minutes of Special Board Meeting on April 23, 2024

Dr. Mike Flores, Chancellor





**MINUTES
SPECIAL BOARD MEETING OF THE BOARD OF TRUSTEES
ALAMO COLLEGS DISTRICT
2222 N. ALAMO ST., SAN ANTONIO TX 78215
TUESDAY, APRIL 23, 2024**

1. CALL TO ORDER

Chair Roberto Zarate called the meeting to order at 6:00 p.m.

2. CERTIFICATION AND POSTING OF NOTICE

Chair Roberto Zarate announced that the notice of the Special Board Meeting has been posted in accordance with the Texas Open Meetings Act, Texas Government Code, Chapter 551.

3. ROLL CALL

The following Trustees were present:

District 2: Gloria Ray, Asst. Secretary

District 3: Anna U. Bustamante

District 4: Dr. Lorraine Pulido, Secretary

District 5: Roberto Zarate, Chair

District 6: Dr. Gene Sprague, Arrived at 6:36 p.m.

District 7: Dr. Yvonne Katz

District 8: Clint Kingsberry, Vice Chair, Arrived at 6:09 p.m.

Student Trustee: Brandon Aviado

Presiding Administrator: Dr. George Railey, Vice Chancellor of Academic Success

The following Trustees were not present:

District 1: Joe Alderete, Jr

District 9: Leslie Sachanowicz

4. PLEDGE OF ALLEGIANCE

The pledge was recited.

5. CITIZENS TO BE HEARD

5.A. There were no citizens to be heard

6. EXECUTIVE SESSION

NO EXECUTIVE SESSION

7. RECONVENE OPEN MEETING

NO EXECUTIVE SESSION

8. RECOGNITIONS

8.A. Recognition of Outgoing Primary and Alternate Student Trustees

The Board of Trustees recognized outgoing Primary Student Trustee Brandon Aviado and outgoing Alternate Student Trustee Arali Garica.

9. **SPECIAL BOARD MEETING**

9.A. Consideration, Discussion and Possible Action on Appointment of Student Trustee and Alternate

Brandon Aviado, Primary Student Trustee, presented on the Appointment of Student Trustee and Alternate 2024-2025. This included Board Policy B.11.1: Student Trustee, 2024-2025 Student Trustee Candidates, and Interviews.

- 9.A.1) Alex Midkiff, Northeast Lakeview College
- 9.A.2) Wilhelm Watson, Northwest Vista College
- 9.A.3) Eliron Rosin, St. Philip's College
- 9.A.4) Jada Valdez, San Antonio College
- 9.A.5) Logan Martinez, Palo Alto College

Primary Student Trustee Vote

Round 1:

No student received 5 votes or more in round 1.

Trustee	Vote for
District 2: Gloria Ray	Logan Martinez
District 3: Anna U. Bustamante	Alexander Midkiff
District 4: Dr. Lorraine Pulido	Jada Valdez
District 5: Roberto Zarate	Logan Martinez
District 6: Dr. Gene Sprague	Eliron Rosin
District 7: Dr. Yvonne Katz	Eliron Rosin
District 8: Clint Kingsberry	Jada Valdez

Round 2:

No student received 5 or more votes in round 2.

Trustee	Vote for
District 2: Gloria Ray	Eliron Rosin
District 3: Anna U. Bustamante	Logan Martinez
District 4: Dr. Lorraine Pulido	Logan Martinez
District 5: Roberto Zarate	Logan Martinez
District 6: Dr. Gene Sprague	Eliron Rosin
District 7: Dr. Yvonne Katz	Eliron Rosin
District 8: Clint Kingsberry	Logan Martinez

Round 3:

Logan Martinez received 5 or more votes constituting a majority of the membership of the Board and was declared the Primary Student Trustee of the Alamo Colleges District.

Trustee	Vote for
District 2: Gloria Ray	Logan Martinez
District 3: Anna U. Bustamante	Logan Martinez
District 4: Dr. Lorraine Pulido	Logan Martinez
District 5: Roberto Zarate	Logan Martinez
District 6: Dr. Gene Sprague	Logan Martinez
District 7: Dr. Yvonne Katz	Logan Martinez
District 8: Clint Kingsberry	Logan Martinez

Alternate Student Trustee Vote

Round 1:

Eliron Rosin received 5 or more votes constituting a majority of the membership of the Board and was declared the Alternate Student Trustee of the Alamo Colleges District.

Trustee	Vote for
District 2: Gloria Ray	Eliron Rosin
District 3: Anna U. Bustamante	Alexander Midkiff
District 4: Dr. Lorraine Pulido	Eliron Rosin
District 5: Roberto Zarate	Eliron Rosin
District 6: Dr. Gene Sprague	Eliron Rosin
District 7: Dr. Yvonne Katz	Eliron Rosin
District 8: Clint Kingsberry	Jada Valdez

9.B. Swearing in of Student Trustee and Alternate Student Trustee

Brandon Aviado, former Primary Student Trustee, swore in Logan Martinez as Primary Student Trustee, and Arali Garcia, former Alternate Student Trustee, swore in Eliron Rosin as Alternate Student Trustee for the Alamo Colleges District.

10. **ADJOURNMENT**

There being no further business, Chari Robert Zarate adjourned the meeting at 7:54 p.m.



 Andria Bernal
 Districts Projects Coordinator



Date: May 16, 2024

To: Denise Wilson - Board Liaison

From: Frank Cortez – District Director of Internal Audit

Subject: Internal Audit Department Monthly Activity Report for May 2024 Board Meeting

This report provides information on internal audit activities, current projects’ statuses, and accomplishments related to the Alamo Colleges’ Strategic Objectives of Student Success, Principle-Centered Leadership, and Performance Excellence.

Goal III. Performance Excellence

Current Projects:

Project	Description	Percent Complete	Target Comply. Date
Planning Phase			
Third-Party Vendor Audit	On temporary hold	5%	7/26/2024
Fieldwork Phase			
Cloud Usage & Security Audit	Requesting documents for testing	15%	7/5/2024
AlamoPROMISE Audit	Requesting data for testing	30%	6/28/2024
Reporting Phase			
HR Hiring Process Audit	Draft report in progress	90%	6/14/2024
Ethics-Related Audit	Final draft report completed and issued to Management	95%	5/27/2024

Other Activities:

Activity	Description	Date
New Supervisor Orientation Training	The Internal Audit Director delivered a presentation on “Supervisor Responsibilities.”	4/30/2024
Special Request – Finance and Fiscal Services	Assisted with gathering documents requested by the External Auditors for the Single Audit	4/30/2024
Ethics Point Case 904	Memo issued	5/2/2024
Ethics Point Case 901	Memo issued	5/2/2024
Ethics Point Case 801	Memo issued	5/3/2024
District Investigation Request	Internal Audit is working with TOSI on an ongoing multi-phase investigation.	Ongoing
Alamo Colleges Risk Assessment	Risk Assessment interviews with Executive Management and College Presidents to begin in May 2024	Ongoing
Leadership Training	The Director participated in the Alamo Colleges 2024 Leadership Development Program.	5/2/2024

Discussion and Possible Action on Acceptance of Private Gifts to the Alamo Colleges Foundation and Alamo Colleges District

Presented to the **ALAMO COLLEGES DISTRICT BOARD OF TRUSTEES** on May 21, 2024

MINUTE ORDER

"The Board of Trustees hereby accepts this gift receipt report on the Monthly Financial Statement on private gifts made in March 2024."

PURPOSE

Provide information on donations received by the Alamo Colleges District & the Alamo Colleges Foundation, Inc.

BACKGROUND

To provide students with scholarships thereby enabling them to complete their college education and to provide faculty and staff with financial program support to further student enrichment.

IMPLICATIONS

Financial: Total Gifts Received for the Month **\$999,386.57**

Cost: NA

Strategic Plan: Goal II – Supports student success

Employee Services: NA

ATTACHMENTS: Private Gifts and the Monthly Financial Statement on Project Activity to the Alamo Colleges (17 pages)

DocuSigned by:

 7245B85737F1486... 5/1/2024

Barton T. Simpson Date
 Executive Director, Institutional Advancement
 Alamo Colleges District & Alamo Colleges Foundation, Inc.

Dr. Mike Flores, Chancellor



ALAMO
COLLEGES
DISTRICT



**OFFICE OF INSTITUTIONAL ADVANCEMENT
& ALAMO COLLEGES FOUNDATION
GIFTS REPORT
March 2024
May 21, 2024 BOARD REPORT**

Donor Name	Soft Credit Recipient Name	Gift Date	Fund Description	Honor / Memorial Name
AAFP		03/27/2024	PAC Fest	
Fernando Acevedo		03/01/2024	AlamoPROMISE Endowment Scholarship	
Stephanie A. Acuna		03/01/2024	AlamoPROMISE Endowment Scholarship	
Leticia M. Adams		03/01/2024	San Antonio College Endowment Fund	
Kristabel Agüero		03/01/2024	Jessica's Project	
Kristabel Agüero		03/01/2024	President's Unrestricted SPC	
Elizabeth Aguilar-Villarreal		03/01/2024	Samantha Tapia Formative Endowed Scholarship	
Elizabeth Aguilar-Villarreal		03/01/2024	PAC SHARE Program	
Alfred N. Alaniz		03/01/2024	Empowerment Center Program	
Alfred N. Alaniz		03/01/2024	General SAC Scholarship	
Alfred N. Alaniz		03/01/2024	SAC Student Support Fund	
Anonymous		03/01/2024	SAC Mexican American Studies (MAS) Program	
Diane Alertas-Jacobs		03/01/2024	SPC Alumni Association Scholarship	
Diane Alertas-Jacobs		03/01/2024	Artemisia Bowden Memorial Endowed Scholarship	
Diane Alertas-Jacobs		03/01/2024	Dr. Adena Williams Loston Presidential Scholarship	
Diane Alertas-Jacobs		03/01/2024	General SPC Scholarship	
Wayne S. Alexander		03/26/2024	AlamoPROMISE Endowment Scholarship	
Rosalinda Almanza-Martinez		03/01/2024	Dr. Veronica R. Garcia President's Leadership Scholarship	
Rosalinda Almanza-Martinez		03/01/2024	Nighthawk Nest Program	
Rosalinda Almanza-Martinez		03/01/2024	NLC Veteran's Center	
Rosalinda Almanza-Martinez		03/01/2024	Betty Cunningham FORMATIVE Endowed Scholarship 9/7/2025	
Anonymous		03/01/2024	Beverly Evans Memorial NVC Student Live Scholarship	
Anonymous		03/01/2024	Dr. Jacqueline Claunch Legacy Endowed Formative Scholarship	
Anonymous		03/01/2024	NVC Faculty / Staff Scholarship	
Anonymous		03/01/2024	Library Media Center NVC	
Anonymous		03/01/2024	Vista Food Pantry	
Altrusa International Foundation of North San Antonio Texas		03/13/2024	General Foundation Scholarship Fund	
Michael A. Alvarado		03/01/2024	AlamoPROMISE Endowment Scholarship	
Nicholas E. Alvarado		03/01/2024	Student Emergency Fund	
Gina A. Alvarez		03/01/2024	Empowerment Center Program	
Jennifer A. Alvarez		03/01/2024	General SPC Scholarship	
Jennifer A. Alvizo		03/01/2024	Vista Food Pantry	
Anonymous		03/24/2024	Masters Leadership Program (MLP) Scholarship	
Kirsten P. Anderson		03/01/2024	Student Leadership Institute - Employee Giving Scholarship	
Wesley L. Anderson		03/01/2024	Dennis Gittinger Endowed Scholarship for Mathematics	
Wesley L. Anderson		03/01/2024	Vista Food Pantry	
Hayley Aniol		03/01/2024	SPC GED Program Fund	
Hayley Aniol		03/01/2024	THCA Milton Guess Endowed Scholarship	
Hayley Aniol		03/01/2024	Tourism, Hospitality, Culinary Arts (THCA) Scholarship	
Anonymous		03/08/2024	Golf Tournament SPC	
Anonymous		03/12/2024	PAC Fest	
Anonymous		03/06/2024	SPC Alumni Association Scholarship	
Rosantina G. Aranda		03/21/2024	Mosaico AlamoPROMISE Event	
Tyler A. Archer		03/01/2024	Samantha Tapia Formative Endowed Scholarship	
Tyler A. Archer		03/01/2024	PAC SHARE Program	
David Ardin		03/01/2024	General Foundation Scholarship Fund	
Rachel V. Armendariz		03/01/2024	Student Emergency Fund	
Griselda F. Arocha		03/01/2024	General Foundation Scholarship Fund	
Andres C. Arredondo		03/01/2024	Artemisia Bowden Memorial Endowed Scholarship	
Andres C. Arredondo		03/01/2024	Community of Automotive Professionals	
Andres C. Arredondo		03/01/2024	General SPC Scholarship	
Nora E. Arredondo		03/01/2024	Samantha Tapia Formative Endowed Scholarship	
Jean P. Arreguin		03/01/2024	Employee Benevolence Fund	
Salvador Arriaga		03/01/2024	Dr. Adena Williams Loston Presidential Scholarship	
Salvador Arriaga		03/01/2024	General SPC Scholarship	
Rodell G. Asher		03/01/2024	Student Leadership Institute - Employee Giving Scholarship	
Karla P. Avila		03/01/2024	Student Emergency Fund	
Karla P. Avila		03/01/2024	PAC LeadHERS	
Christy Babu		03/01/2024	Vista Food Pantry	
Leah R. Badillo		03/01/2024	PAC LeadHERS	
Leah R. Badillo		03/01/2024	President's Unrestricted PAC	
Vanessa J. Bailey		03/01/2024	Annual Fund	
Cynthia A. Baker		03/01/2024	ECO-Centro Program	
Jeff Balfour		03/21/2024	Mosaico AlamoPROMISE Event	
Sarah B. Ball		03/01/2024	Vista Food Pantry	
Natalie Barajas		03/01/2024	AlamoPROMISE Endowment Scholarship	
Natalie Barajas		03/01/2024	Student Emergency Fund	
Jessica C. Barnes		03/01/2024	AlamoPROMISE Endowment Scholarship	
Jessica C. Barnes		03/01/2024	Student Emergency Fund	
Roxanne Barrera		03/01/2024	Scobee Education Center Programs	
Tracy Barrett		03/22/2024	Mosaico AlamoPROMISE Event	
Tracy Barrett		03/30/2024	Mosaico AlamoPROMISE Event	
Rolando Barrientez		03/01/2024	First Responders Academy-Formative Endowment	
Natasha Bass		03/04/2024	Masters Leadership Program (MLP) Scholarship	
Shirley A. Bass-Wright		03/01/2024	Kevin Schantz Memorial Scholarship	
Shirley A. Bass-Wright		03/01/2024	Dr. Adena Williams Loston Presidential Scholarship	
Shirley A. Bass-Wright		03/01/2024	General SPC Scholarship	
Shirley A. Bass-Wright		03/01/2024	Jessica's Project	
Shirley A. Bass-Wright		03/01/2024	Woodard-Clarke-Durvan Scholarship	
Yvette P. Baxter		03/01/2024	Employee Benevolence Fund	
Anonymous		03/01/2024	OCI Solar Power Program	
Anonymous		03/01/2024	Professional Aviation Maintenance Scholarship	
Gilberto Becerra		03/01/2024	PAC SHARE Program	
Ute Bedemann		03/25/2024	General NVC Scholarship	
Dafney D. Bell		03/01/2024	PAC LeadHERS	
Terry M. Bell		03/01/2024	General NVC Scholarship	
Terry M. Bell		03/01/2024	Vista Food Pantry	
Jodi M. Bellamy		03/01/2024	Safe S.P.A.C.E. (Supporting People through Advocacy, Care and Equity)	
Anonymous		03/21/2024	Mosaico AlamoPROMISE Event	
Benevity Community Impact Fund	William Sammons	03/29/2024	AlamoPROMISE Endowment Scholarship	
Greta Bennett		03/04/2024	Celestine M & Remethia D Winters Scholarship	Celestine Winters, Remethia D Winters
Tia Benning		03/04/2024	Masters Leadership Program (MLP) Scholarship	
Meredith N. Bess		03/01/2024	Dr. Adena Williams Loston Presidential Scholarship	
Molly Biglari		03/27/2024	General Foundation Scholarship Fund	
Mary E. Bingham		03/01/2024	Employee Benevolence Fund	
Eddie A. Bishop		03/01/2024	Debra A. Morgan Endowed Scholarship	
Eddie A. Bishop		03/01/2024	Dennis Gittinger Endowed Scholarship for Mathematics	

Donor Name	Soft Credit Recipient Name	Gift Date	Fund Description	Honor / Memorial Name
Eddie A. Bishop		03/01/2024	Vista Food Pantry	
Lisa V. Black		03/01/2024	Vista Food Pantry	
Michael S. Blackwell		03/01/2024	General NVC Scholarship	
Michael S. Blackwell		03/01/2024	Vista Food Pantry	
Nicholas G. Blakeney		03/01/2024	James B. Riley Formative Endowed Scholarship	
Nicholas G. Blakeney		03/01/2024	President's Unrestricted PAC	
Nicholas G. Blakeney		03/01/2024	Samantha Tapia Formative Endowed Scholarship	
Melaku A. Bogale		03/01/2024	Vista Food Pantry	
Dwayne G. Bohustlav		03/01/2024	SAC Student Support Fund	
Dale Bond		03/28/2024	Masters Leadership Program (MLP) Scholarship	
Veronica Bonebrake		03/01/2024	Annual Fund	
Abreetta Bonner		03/01/2024	NVC Alumni Association Scholarship	
Abreetta Bonner		03/01/2024	NVC Business Council Scholarship	
Abreetta Bonner		03/01/2024	General NVC Scholarship	
Abreetta Bonner		03/01/2024	Vista Food Pantry	
Kristina M. Booth		03/01/2024	AlamoPROMISE Endowment Scholarship	
Tafesse G. Borena		03/01/2024	PAC SHARE Program	
Amy Bosley		03/01/2024	San Antonio peaceCENTER	
Amy Bosley		03/01/2024	Vista Food Pantry	
Vincent Bosquez		03/01/2024	PAC LeadHERS	
Vincent Bosquez		03/01/2024	President's Unrestricted PAC	
Vincent Bosquez		03/01/2024	Samantha Tapia Formative Endowed Scholarship	
Vincent Bosquez		03/01/2024	PAC SHARE Program	
Aracely R. Bowling		03/01/2024	PAC LeadHERS	
Aracely R. Bowling		03/01/2024	Samantha Tapia Formative Endowed Scholarship	
Aracely R. Bowling		03/01/2024	PAC SHARE Program	
Gary Bowling		03/01/2024	NVC Alumni Association Scholarship	
Gary Bowling		03/01/2024	General NVC Scholarship	
Gary Bowling		03/01/2024	Jane Moser Drum Encouragement Endowment Program	
Gary Bowling		03/01/2024	San Antonio peaceCENTER	
Gary Bowling		03/01/2024	Vista Food Pantry	
Laura B. Boyer		03/01/2024	NLC President Cares Unrestricted Fund	
Linda L. Boyer-Owens		03/01/2024	AlamoPROMISE Endowment Scholarship	
Margaret Boykin		03/01/2024	AlamoPROMISE Endowment Scholarship	
Diana Bradford		03/01/2024	San Antonio peaceCENTER	
Diana Bradford		03/01/2024	Vista Food Pantry	
Kelli L. Bradshaw		03/01/2024	General NVC Scholarship	
Kelli L. Bradshaw		03/01/2024	Vista Food Pantry	
Edna I. Breuer		03/01/2024	AlamoPROMISE Endowment Scholarship	
Edna I. Breuer		03/01/2024	Annual Fund	
Edna I. Breuer		03/01/2024	Employee Benevolence Fund	
Edna I. Breuer		03/01/2024	General Foundation Scholarship Fund	
Edna I. Breuer		03/01/2024	Student Emergency Fund	
Phyllis Bright		03/01/2024	Artemisia Bowden Memorial Endowed Scholarship	
Richard G. Brindle		03/01/2024	Student Emergency Fund	
Alyssa R. Briscoe		03/01/2024	Student Emergency Fund	
Cynthia M. Broadnax		03/01/2024	General SAC Scholarship	
Cynthia M. Broadnax		03/01/2024	SAC Student Support Fund	
Broadway Bank		03/13/2024	Interim Program	
Denetria Brooks-James		03/01/2024	SAC Student Support Fund	
Christina M. Brown		03/01/2024	General NVC Scholarship	
Christina M. Brown		03/01/2024	San Antonio peaceCENTER	
Christina M. Brown		03/01/2024	Vista Food Pantry	
Daniel C. Brown		03/29/2024	Golf Tournament SPC	
Holly D. Brown		03/01/2024	PAC LeadHERS	
Veronica I. Buendia		03/01/2024	NVC Personal Fitness Training Scholarship	
Veronica I. Buendia		03/01/2024	NVC Compassion (President's Unrestricted Fund)	
Alejandra Bueno		03/01/2024	International Programs Support Fund	
Mia M. Buentello		03/01/2024	AlamoPROMISE Endowment Scholarship	
Matthew J. Burch		03/01/2024	Vista Food Pantry	
Karen Burkey		03/03/2024	Jack Stone Award for New Music	
Michelle D. Burnett		03/01/2024	Dr. Adena Williams Loston Presidential Scholarship	Beth May
Amy H. Burton		03/01/2024	Vista Food Pantry	
Gerald F. Busald		03/01/2024	General SAC Scholarship	
Joshua A. Bustillo		03/01/2024	PAC LeadHERS	
Joshua A. Bustillo		03/01/2024	PAC SHARE Program	
Valerie P. Butter		03/01/2024	AlamoPROMISE Endowment Scholarship	
Valerie P. Butter		03/01/2024	PAC LeadHERS	
Valerie P. Butter		03/01/2024	PAC SHARE Program	
Camilyah L. Buxton		03/01/2024	SPC Alumni Association Scholarship	
Camilyah L. Buxton		03/01/2024	Artemisia Bowden Memorial Endowed Scholarship	
Camilyah L. Buxton		03/01/2024	Clarence Norris Endowed Scholarship	
Camilyah L. Buxton		03/01/2024	Dr. Adena Williams Loston Presidential Scholarship	
Camilyah L. Buxton		03/01/2024	General SPC Scholarship	
Lauren Byrd		03/19/2024	General Foundation Scholarship Fund	
Keyhla I. Calderon Lugo		03/01/2024	James B. Riley Formative Endowed Scholarship	
Keyhla I. Calderon Lugo		03/01/2024	PAC LeadHERS	
Keyhla I. Calderon Lugo		03/01/2024	President's Unrestricted PAC	
Keyhla I. Calderon Lugo		03/01/2024	Samantha Tapia Formative Endowed Scholarship	
Keyhla I. Calderon Lugo		03/01/2024	PAC SHARE Program	
Judit V. Camargo		03/01/2024	Beverly Evans Memorial NVC Student Live Scholarship	
Judit V. Camargo		03/01/2024	Betty Cunningham FORMATIVE Endowed Scholarship 9/7/2025	
Judit V. Camargo		03/01/2024	San Antonio peaceCENTER	
Judit V. Camargo		03/01/2024	Vista Food Pantry	
Beatrice E. Canales		03/01/2024	Dr. Alice Johnson Children's Library	
Beatrice E. Canales		03/01/2024	Norma's Nook Playground Endowed Program Fund	
Beatrice E. Canales		03/01/2024	President's Unrestricted SAC	
Gloria F. Canestaro		03/01/2024	SAC Mexican American Studies (MAS) Program	
Stephen Canto		03/27/2024	Interim Program	
Gaston Cantu		03/01/2024	AlamoPROMISE Endowment Scholarship	
Gaston Cantu		03/01/2024	Annual Fund	
Gaston Cantu		03/01/2024	Student Emergency Fund	
Gaston Cantu		03/01/2024	PAC - Educate South	
Gaston Cantu		03/01/2024	President's Unrestricted PAC	
Anonymous		03/01/2024	General Foundation Scholarship Fund	
Marjane J. Cardenas		03/01/2024	AlamoPROMISE Endowment Scholarship	
Marjane J. Cardenas		03/01/2024	Employee Benevolence Fund	

Donor Name	Soft Credit Recipient Name	Gift Date	Fund Description	Honor / Memorial Name
Maryjane J. Cardenas		03/01/2024	General Foundation Scholarship Fund	
Maryjane J. Cardenas		03/01/2024	Student Emergency Fund	
Charlotte Carlson		03/21/2024	Mosaico AlamoPROMISE Event	
Paula Carlson		03/21/2024	Mosaico AlamoPROMISE Event	
Paula Carlson		03/21/2024	Mosaico AlamoPROMISE Event	
Margaret S. Carnegie-Diaz		03/01/2024	Nighthawk Nest Program	
Jill Carpenter		03/21/2024	Mosaico AlamoPROMISE Event	
Melissa Carpenter		03/21/2024	Mosaico AlamoPROMISE Event	
Selso M. Casares		03/01/2024	PAC SHARE Program	
Phillip Casarez		03/01/2024	SAC Honors Academy	
Phillip Casarez		03/01/2024	SAC Honors Academy Scholarship	
Ursella A. Castaneda		03/01/2024	Nighthawk Nest Program	
Bertha C. Castellanos		03/01/2024	Empowerment Center Program	
Caroline K. Castellanos		03/01/2024	Vista Food Pantry	
Enrique C. Castillo		03/01/2024	President's Unrestricted SAC	
Eric Castillo		03/01/2024	DREAMers Scholarship	
Eric Castillo		03/01/2024	International Programs Support Fund	
Eric Castillo		03/01/2024	San Antonio peaceCENTER	
Graciela Castillo		03/01/2024	General NVC Scholarship	
Graciela Castillo		03/01/2024	Vista Food Pantry	
Jeanette J. Castillo		03/01/2024	AlamoPROMISE Endowment Scholarship	
Angela M. Cavazos		03/01/2024	Betty Cunningham FORMATIVE Endowed Scholarship 9/7/2025	
Angela M. Cavazos		03/01/2024	Vista Food Pantry	
Isabel S. Cavazos		03/01/2024	PAC SHARE Program	
Catriona Cavender		03/21/2024	Mosaico AlamoPROMISE Event	
Zak D. Cernoch		03/01/2024	Debra A. Morgan Endowed Scholarship	
Zak D. Cernoch		03/01/2024	Betty Cunningham FORMATIVE Endowed Scholarship 9/7/2025	
Brad S. Chandler		03/01/2024	Taylor & Ronda Chandler Math & Sciences Endowed Scholarship	
Anonymous		03/01/2024	Artemisia Bowden Memorial Endowed Scholarship	
Anonymous		03/01/2024	Dr. Adena Williams Loston Presidential Scholarship	
Anonymous		03/01/2024	Ruth Jones McClendon	
David Chavera		03/01/2024	SAC Honors Academy	
David Chavera		03/01/2024	SAC Student Support Fund	
Maria A. Chavez		03/01/2024	Empowerment Center Program	
Omar J. Chavira		03/01/2024	Vista Food Pantry	
Chester F. Hunt Trust		03/14/2024	Hunt Family Journalism Endowed Scholarship	Chester F. Hunt
Deborah K. Christian		03/05/2024	Masters Leadership Program (MLP) Scholarship	
Cindy Taylor Group LLC		03/26/2024	Mosaico AlamoPROMISE Event	
Philip Cirilo		03/01/2024	Artemisia Bowden Memorial Endowed Scholarship	
Alison Sean D. Clark		03/01/2024	Taylor & Ronda Chandler Math & Sciences Endowed Scholarship	
Lenell C. Clay		03/01/2024	President's Unrestricted SAC	
Thomas S. Cleary		03/01/2024	AlamoPROMISE Endowment Scholarship	
Thomas S. Cleary		03/01/2024	Annual Fund	
Kimberly A. Cleveland		03/01/2024	Student Leadership Institute - Employee Giving Scholarship	
Virginia C. Cmontezfstbusy		03/01/2024	NVC Alumni Association Scholarship	
Virginia C. Cmontezfstbusy		03/01/2024	San Antonio peaceCENTER	
Ann M. Coldwater		03/01/2024	SAC Student Support Fund	
David R. Collazo		03/01/2024	AlamoPROMISE Endowment Scholarship	
David R. Collazo		03/01/2024	Annual Fund	
David R. Collazo		03/01/2024	Employee Benevolence Fund	
David R. Collazo		03/01/2024	General Foundation Scholarship Fund	
David R. Collazo		03/01/2024	Student Emergency Fund	
Grace L. Collett		03/01/2024	Annual Fund	
Keith G. Collins		03/01/2024	Dr. Veronica R. Garcia President's Leadership Scholarship	
Keith G. Collins		03/01/2024	General NLC Scholarship	
Jacob P. Colunga		03/01/2024	Dr. Adena Williams Loston Presidential Scholarship	
Jennifer D. Comedy-Holmes		03/01/2024	Betty Cunningham FORMATIVE Endowed Scholarship 9/7/2025	
Jennifer D. Comedy-Holmes		03/01/2024	General NVC Scholarship	
Jennifer D. Comedy-Holmes		03/01/2024	San Antonio peaceCENTER	
CommonWeath Charitable Fund	Shelley A. Friend	03/20/2024	Seeds of Leadership Endowed Scholarship	
Community First Health Plans		03/08/2024	PAC Fest	
Esther M. Conejo		03/01/2024	Beverly Evans Memorial NVC Student Live Scholarship	
Esther M. Conejo		03/01/2024	Betty Cunningham FORMATIVE Endowed Scholarship 9/7/2025	
Kevin J. Conton		03/01/2024	SAC Student Support Fund	
Anonymous		03/01/2024	Empowerment Center Program	
Anonymous		03/01/2024	General SAC Scholarship	
Anonymous		03/01/2024	SAC Student Support Fund	
Leticia R. Contreras		03/01/2024	PAC SHARE Program	
Jessica A. Cooper		03/01/2024	Student Emergency Fund	
Jessica A. Cooper		03/01/2024	Dr. Adena Williams Loston Presidential Scholarship	
Joseph Coppola		03/01/2024	PAC SHARE Program	
Maria H. Coronel		03/01/2024	AlamoPROMISE Endowment Scholarship	
Maria H. Coronel		03/01/2024	Annual Fund	
Maria H. Coronel		03/01/2024	Employee Benevolence Fund	
Maria H. Coronel		03/01/2024	General Foundation Scholarship Fund	
Maria H. Coronel		03/01/2024	Student Emergency Fund	
Christina M. Cortez		03/01/2024	Dr. Mordecai & Mrs. Dahpne Brownlee Scholarship	
Federico A. Cortez		03/01/2024	Samantha Tapia Formative Endowed Scholarship	
Federico A. Cortez		03/01/2024	PAC SHARE Program	
Francisco Cortez		03/01/2024	Annual Fund	
Rebecca Cortez		03/01/2024	Student Emergency Fund	
Jeralynn Cossman		03/27/2024	Masters Leadership Program (MLP) Scholarship	
Trina D. Cowan		03/01/2024	Psychology Department Scholarship	
CPS Energy		03/13/2024	Interim Program	
Lloyd G. Crenwelge		03/01/2024	Beverly Evans Memorial NVC Student Live Scholarship	
Sharon A. Crockett-Ray		03/01/2024	Ralph and Blanche Crockett Memorial Scholarship	
Yolanda R. Crooms		03/01/2024	Employee Benevolence Fund	
Tomeka Cross		03/01/2024	STEM SPC Scholarship	
Tomeka Cross		03/01/2024	Student Engagement Scholarship SPC	
William R. Crow		03/19/2024	Masters Leadership Program (MLP) Scholarship	
Tonya R. Crowley		03/01/2024	General SAC Scholarship	
Larry M. Crutsinger		03/01/2024	Eastside Education and Training Center Program Support	
Clarissa J. Cruz		03/01/2024	Dr. Mordecai & Mrs. Dahpne Brownlee Scholarship	
Jessica S. Cruz		03/01/2024	General SPC Scholarship	
Jessica S. Cruz		03/01/2024	Safe S.P.A.C.E. (Supporting People through Advocacy, Care and Equity)	
Jessica S. Cruz		03/01/2024	SPC GED Program Fund	
Roxanne M. Cruz		03/01/2024	SAC Student Support Fund	

Donor Name	Soft Credit Recipient Name	Gift Date	Fund Description	Honor / Memorial Name
Sarah I. Cuellar		03/01/2024	AlamoPROMISE Endowment Scholarship	
Susan Cunningham		03/01/2024	David E Mrizek Endowed Scholarship Fund	
Susan Cunningham		03/01/2024	Ron Lucke Speech & Drama Scholarship	
Scott D'Amico		03/01/2024	General Foundation Scholarship Fund	
Marika A. Dabney		03/01/2024	AlamoPROMISE Endowment Scholarship	
Ruth A. Dalrymple		03/01/2024	AlamoPROMISE Endowment Scholarship	
Ruth A. Dalrymple		03/01/2024	Annual Fund	
Ruth A. Dalrymple		03/01/2024	General Foundation Scholarship Fund	
Ruth A. Dalrymple		03/01/2024	Student Emergency Fund	
Patrick F. Daniels		03/01/2024	SPC Alumni Association Scholarship	
Patrick F. Daniels		03/01/2024	Dr. Adena Williams Loston Presidential Scholarship	
Cheryl E. Davis		03/31/2024	William C. Davis Endowed Scholarship	
Cheryl E. Davis		03/20/2024	William C. Davis Endowed Scholarship	
Max Davis		03/01/2024	Annual Fund	
Sylvia M. Davis		03/01/2024	Dr. Veronica R. Garcia President's Leadership Scholarship	
Sylvia M. Davis		03/01/2024	General NLC Scholarship	
Sylvia M. Davis		03/01/2024	Nighthawk Nest Program	
Randall N. Dawson		03/01/2024	SPC Alumni Association Scholarship	
Randall N. Dawson		03/01/2024	Artemisia Bowden Memorial Endowed Scholarship	
Randall N. Dawson		03/01/2024	Clarence Norris Endowed Scholarship	
Randall N. Dawson		03/01/2024	Dr. Adena Williams Loston Presidential Scholarship	
Randall N. Dawson		03/01/2024	General SPC Scholarship	
Adrianna A. De Hoyos		03/01/2024	Employee Benevolence Fund	
Adrianna A. De Hoyos		03/01/2024	Student Emergency Fund	
Teresa De La Cruz		03/01/2024	Dr. Veronica R. Garcia President's Leadership Scholarship	
Amber A. De La Garza		03/01/2024	NLC Veteran's Center	
Pamela S. De La Garza		03/01/2024	General Foundation Scholarship Fund	
Pamela S. De La Garza		03/01/2024	General NVC Scholarship	
Pamela S. De La Garza		03/01/2024	San Antonio peaceCENTER	
Pamela S. De La Garza		03/01/2024	Vista Food Pantry	
Richard De La Garza		03/01/2024	Samantha Tapia Formative Endowed Scholarship	
Anonymous		03/01/2024	PAC SHARE Program	
Rosalind K. De Trevino		03/01/2024	President's Unrestricted SAC	
Luanne T. Decker		03/01/2024	Nighthawk Nest Program	
Yolanda I. Del Villar		03/01/2024	General SAC Scholarship	
Nancy G. Delacera		03/01/2024	Beverly Evans Memorial NVC Student Live Scholarship	
Nancy G. Delacera		03/01/2024	CPS Energy/Dr. Homer Guevara Jr. End for Business, Economics, and Government Majors	
Nancy G. Delacera		03/01/2024	General NVC Scholarship	
Nancy G. Delacera		03/01/2024	NVC Arts	
Nancy G. Delacera		03/01/2024	Vista Food Pantry	
Stephen Delgado		03/21/2024	Mosaico AlamoPROMISE Event	
Vanessa A. Demont		03/01/2024	Dr. Veronica R. Garcia President's Leadership Scholarship	
Vanessa A. Demont		03/01/2024	Nighthawk Nest Program	
Jillian L. Denman		03/01/2024	SAC Student Support Fund	
Edward Diaz		03/01/2024	Dr. Alice Johnson Children's Library	
Mariana A. Diaz		03/01/2024	PAC LeadHERS	
Mariana A. Diaz		03/01/2024	Samantha Tapia Formative Endowed Scholarship	
Mariana A. Diaz		03/01/2024	PAC SHARE Program	
Jactyn G. Dinscore		03/01/2024	President's Unrestricted PAC	
LeAnn Dinsdale		03/01/2024	Dr. Adena Williams Loston Presidential Scholarship	
LeAnn Dinsdale		03/01/2024	General SPC Scholarship	
LeAnn Dinsdale		03/01/2024	PNC Small Business & Entrepreneurship Program	
DOCUmation		03/20/2024	Mosaico AlamoPROMISE Event	
Adriana Dominguez		03/01/2024	PAC SHARE Program	
Fannie M. Dominguez		03/01/2024	Dr. Said Fariabi Memorial Endowed Scholarship	
Jessica Dominguez		03/01/2024	President's Unrestricted PAC	
Jessica Dominguez		03/01/2024	PAC SHARE Program	
Katherine B. Doss		03/01/2024	PAC SHARE Program	
Tangila C. Dove		03/01/2024	E. F. "Smiley" & Sandra Williams Endowed Scholarship	
Tangila C. Dove		03/01/2024	Nighthawk Nest Program	
Tangila C. Dove		03/01/2024	NLC President Cares Unrestricted Fund	
Daniel T. Dow		03/01/2024	PAC SHARE Program	
Lucas W. Dowden		03/01/2024	Nighthawk Nest Program	
Lucas W. Dowden		03/01/2024	Vista Food Pantry	
Lucas W. Dowden		03/01/2024	PAC SHARE Program	
Lucas W. Dowden		03/01/2024	SAC Student Support Fund	
Lucas W. Dowden		03/01/2024	Safe S.P.A.C.E. (Supporting People through Advocacy, Care and Equity)	
Shahrazad Dowlatshahi		03/21/2024	Mosaico AlamoPROMISE Event	
Anna Downey		03/27/2024	General Foundation Scholarship Fund	
Cheryl A. Drake		03/01/2024	General Foundation Scholarship Fund	
Annette Duenes		03/01/2024	General SPC Scholarship	
Leticia E. Duncan brosnan		03/01/2024	Student Emergency Fund	
Paul S. Dunn		03/01/2024	Annual Fund	
Meka Durham-Honer		03/08/2024	Annual Fund	Captain Cartize Durhan
Jason V. Easterling		03/01/2024	General Foundation Scholarship Fund	
Jessica L. Edmiston		03/01/2024	General SPC Scholarship	
Educate Texas at Communities Foundation of Texas		03/13/2024	P-TECH Expansion Planning Grant TR-NR	
Educate Texas at Communities Foundation of Texas		03/20/2024	General Foundation Scholarship Fund	
Anna M. Edwards		03/01/2024	Safe S.P.A.C.E. (Supporting People through Advocacy, Care and Equity)	
Austin Elliott		03/24/2024	Mosaico AlamoPROMISE Event	
Dawn L. Elmore		03/01/2024	James C. Elmore II Memorial Art Scholarship	James C. Elmore
James C. Elmore		03/13/2024	James C. Elmore II Memorial Art Scholarship	James C. Elmore
Anonymous		03/01/2024	Strategies for Success - Grant in Aid Scholarship	
Susan L. Escobar		03/01/2024	NVC Digital Media Student Program Support	
Dimona R. Esparza		03/01/2024	Student Emergency Fund	
Francisco Esparza		03/01/2024	Annual Fund	
Raquel M. Espinosa		03/01/2024	NVC Fine & Performing Arts Endowed Scholarship	
Leonila Espinoza		03/01/2024	PAC LeadHERS	
Susan A. Espinoza-Vargas		03/01/2024	Dr. Elizabeth Garza Memorial Endowed Scholarship	
Stephanie R. Estrada		03/01/2024	AlamoPROMISE Endowment Scholarship	
Anonymous		03/01/2024	Faculty Endowment Scholarship	
Anonymous		03/01/2024	Nighthawk Nest Program	
Anna M. Evans		03/01/2024	Psychology Department Scholarship	
Samuel H. Evans		03/01/2024	PAC SHARE Program	
Teresa B. Eyernham		03/01/2024	AlamoPROMISE Endowment Scholarship	
Excelencia in Education		03/01/2024	NLC President Cares Unrestricted Fund	
Shawna J. Fahrenthold		03/01/2024	Economic & Workforce Development Program Fund	

Donor Name	Soft Credit Recipient Name	Gift Date	Fund Description	Honor / Memorial Name
Yves Fanfelle		03/01/2024	President's Unrestricted PAC	
William J. Fanning		03/01/2024	Terracon STEM Scholars Endowed Scholarship	
Richard H. Farias		03/01/2024	Annual Fund	
Marie P. Feldmeier		03/01/2024	General SPC Scholarship	
Anonymous		03/01/2024	Annual Fund	
Anna Lisa Fernandez		03/01/2024	PAC LeadHERS	
Anna Lisa Fernandez		03/01/2024	PAC SHARE Program	
Donald S. Fernandez		03/01/2024	VOTC Veterans Outreach & Transition Center Program	
Robert Fernandez		03/01/2024	AlamoPROMISE Endowment Scholarship	
Robert Fernandez		03/01/2024	Employee Benevolence Fund	
Robert Fernandez		03/01/2024	General Foundation Scholarship Fund	
Thaddeus Fernandez		03/01/2024	AlamoPROMISE Endowment Scholarship	
William Fernandez		03/19/2024	General Foundation Scholarship Fund	
Fidelity Investment	Gregg Winn	03/15/2024	Cecil Winn Endowed Scholarship	Cecil Winn
Fidelity Investment	Robert R. Lende	03/20/2024	Birdien Dobson Lende Nursing Scholarship	
Lanita Fields		03/21/2024	Mosaico AlamoPROMISE Event	
Virginia B. Finster		03/01/2024	SAC Student Support Fund	
Sally A. First	Daniel Mertens	03/25/2024	Vista Food Pantry	
Belinda Flores		03/21/2024	Mosaico AlamoPROMISE Event	
Daniel B. Flores		03/01/2024	SAC Student Support Fund	
Dulce Flores		03/01/2024	Masters Leadership Program (MLP) Scholarship	
Georgia L. Flores		03/01/2024	Nighthawk Nest Program	
Georgia L. Flores		03/01/2024	NLC President Cares Unrestricted Fund	
Jennifer L. Flores		03/01/2024	James B. Riley Formative Endowed Scholarship	
Jennifer L. Flores		03/01/2024	PAC LeadHERS	
Jennifer L. Flores		03/01/2024	President's Unrestricted PAC	
Jennifer L. Flores		03/01/2024	Samantha Tapia Formative Endowed Scholarship	
Jennifer L. Flores		03/01/2024	PAC SHARE Program	
Jorge R. Flores		03/01/2024	General SPC Scholarship	
Melissa A. Flores		03/01/2024	Student Emergency Fund	
Rose M. Flores		03/01/2024	Horticulture Scholarship	
Ruben M. Flores		03/01/2024	Chancellor's Circle of Excellence Fund	
Ruben M. Flores		03/01/2024	GED Empowerment to College Endowed Scholarship	
Rosalinda F. Flores Castillo		03/01/2024	Student Emergency Fund	
Maria S. Flores-Chase		03/01/2024	DREAMers Scholarship	
Maria S. Flores-Chase		03/01/2024	Dr. Veronica R. Garcia President's Leadership Scholarship	
Maria S. Flores-Chase		03/01/2024	Faculty Endowment Scholarship	
Maria S. Flores-Chase		03/01/2024	General NLC Scholarship	
Maria S. Flores-Chase		03/01/2024	Nighthawk Nest Program	
Maria S. Flores-Chase		03/01/2024	NLC President Cares Unrestricted Fund	
Melissa Flores-Valencia		03/01/2024	DREAMers Scholarship	
Melissa Flores-Valencia		03/01/2024	Empowerment Center Program	
Jane E. Focht-Hansen		03/01/2024	Interim Scholarship	
Linda Fogg		03/01/2024	PAC SHARE Program	
Martin B. Fortner		03/01/2024	Dr. Veronica R. Garcia President's Leadership Scholarship	
Martin B. Fortner		03/01/2024	General NLC Scholarship	
Martin B. Fortner		03/01/2024	NLC President Cares Unrestricted Fund	
Eric Foutz		03/21/2024	AlamoPROMISE Endowment Scholarship	
Karl R. Frey		03/01/2024	Faculty Endowment Scholarship	
Karl R. Frey		03/01/2024	General NLC Scholarship	
Karl R. Frey		03/01/2024	NLC President Cares Unrestricted Fund	
Paul A. Frisch		03/01/2024	General Foundation Scholarship Fund	
Russell J. Frohardt		03/01/2024	NVC Alumni Association Scholarship	
Russell J. Frohardt		03/01/2024	General NVC Scholarship	
Russell J. Frohardt		03/01/2024	Jane Moser Drum Encouragement Endowment Program	
Russell J. Frohardt		03/01/2024	San Antonio peaceCENTER	
Russell J. Frohardt		03/01/2024	Vista Food Pantry	
Andrea Fuentes		03/01/2024	PAC Journalism/Mass Communications Program	
Evelene R. Fuentes		03/01/2024	PAC SHARE Program	
Derek Fuller		03/01/2024	Black Student Alliance Scholarship	
Verne Futagawa		03/01/2024	Annual Fund	
Verne Futagawa		03/01/2024	Student Emergency Fund	
Deborah L. Gaitan		03/01/2024	Betty Cunningham FORMATIVE Endowed Scholarship 9/7/2025	
Deborah L. Gaitan		03/01/2024	Jane Moser Drum Encouragement Endowment Program	
Deborah L. Gaitan		03/01/2024	San Antonio peaceCENTER	
Deborah L. Gaitan		03/01/2024	Vista Food Pantry	
Joshua Galat		03/01/2024	PAC LeadHERS	
Joshua Galat		03/01/2024	PAC SHARE Program	
Galen College of Nursing		03/04/2024	PAC Fest	
Chloe Gallegos		03/01/2024	Annual Fund	
Cristela C. Garcia		03/01/2024	Nighthawk Nest Program	
Cristela C. Garcia		03/01/2024	NLC President Cares Unrestricted Fund	
Denise Garcia		03/04/2024	General Foundation Scholarship Fund	
Jason L. Garcia		03/01/2024	Eastside Education and Training Center Program Support	
Jason L. Garcia		03/01/2024	Economic & Workforce Development Program Fund	
Joshua R. Garcia		03/01/2024	PAC SHARE Program	
Mauricio Garcia		03/01/2024	PAC LeadHERS	
Mauricio Garcia		03/01/2024	Samantha Tapia Formative Endowed Scholarship	
Mauricio Garcia		03/01/2024	PAC SHARE Program	
Migdalia Garcia		03/01/2024	San Antonio peaceCENTER	
Migdalia Garcia		03/01/2024	Vista Food Pantry	
Orelia B. Garcia		03/01/2024	International Education Scholarship	
Anonymous		03/01/2024	Dr. Veronica R. Garcia President's Leadership Scholarship	
Anonymous		03/01/2024	Dr. Veronica R. Garcia Presidential Endowed Scholarship	
Bridgette A. Garza		03/01/2024	Janet H. Rangel Memorial Scholarship	
Diann Garza		03/01/2024	SPC Nursing Education Department Faculty Memoriam Scholarship	
Elena S. Garza		03/01/2024	Deason Animal Hospital Scholarship	
Linda T. Garza		03/01/2024	General Foundation Scholarship Fund	
Anonymous		03/01/2024	President's Unrestricted PAC	
Vanessa A. Garza		03/01/2024	Employee Benevolence Fund	
Vanessa A. Garza		03/01/2024	General Foundation Scholarship Fund	
Vanessa A. Garza		03/01/2024	Student Emergency Fund	
Vivian Garza-Steele		03/05/2024	Masters Leadership Program (MLP) Scholarship	
Vivian Garza-Steele		03/15/2024	Masters Leadership Program (MLP) Scholarship	
Amy S. Gates		03/01/2024	AlamoPROMISE Endowment Scholarship	
Amy S. Gates		03/01/2024	Student Emergency Fund	
Amy S. Gates		03/01/2024	General SAC Scholarship	

Donor Name	Soft Credit Recipient Name	Gift Date	Fund Description	Honor / Memorial Name
Amy S. Gates		03/01/2024	SAC Student Support Fund	
Pamela D. Gauna		03/01/2024	NLC College Mentoring Program	
Pamela D. Gauna		03/01/2024	General NLC Scholarship	
Pamela D. Gauna		03/01/2024	Nighthawk Nest Program	
Edward D. Gayden		03/01/2024	Dr. Adena Williams Loston Presidential Scholarship	
Edward D. Gayden		03/01/2024	General SPC Scholarship	
Maja B. Gerdin		03/01/2024	Debra A. Morgan Endowed Scholarship	
Lestie B. Germer		03/01/2024	Nighthawk Nest Program	
Andrew T. Gignac		03/01/2024	Seats of Support Program Support Fund	
Dennis J. Gittinger		03/01/2024	Debra A. Morgan Endowed Scholarship	
Jose Gloria		03/01/2024	Janet H. Rangel Memorial Scholarship	
Deretha R. Goforth		03/01/2024	Dr. Adena Williams Loston Presidential Scholarship	
Deretha R. Goforth		03/20/2024	Golf Tournament SPC	
Cressida Goloby		03/01/2024	Artemisia Bowden Memorial Endowed Scholarship	
Mary K. Gomez		03/01/2024	General Foundation Scholarship Fund	
Yalilet G. Gomez		03/01/2024	PAC LeadHERS	
Yalilet G. Gomez		03/01/2024	PAC SHARE Program	
Brenda Gonzales		03/01/2024	Student Emergency Fund	
Anonymous		03/21/2024	General Foundation Scholarship Fund	
Jonathon R. Gonzales		03/01/2024	Vista Food Pantry	
Pablo F. Gonzales		03/01/2024	James B. Riley Formative Endowed Scholarship	
Pablo F. Gonzales		03/01/2024	PAC LeadHERS	
Pablo F. Gonzales		03/01/2024	President's Unrestricted PAC	
Pablo F. Gonzales		03/01/2024	Samantha Tapia Formative Endowed Scholarship	
Pablo F. Gonzales		03/01/2024	PAC SHARE Program	
Anonymous		03/01/2024	Debra A. Morgan Endowed Scholarship	
Anonymous		03/01/2024	Dennis Gittinger Endowed Scholarship for Mathematics	
Anonymous		03/01/2024	Beverly Evans Memorial NVC Student Live Scholarship	
Anonymous		03/01/2024	Lynne Dean Endowed Scholarship	
Anonymous		03/01/2024	Vista Food Pantry	
Teresa C. Gonzales		03/01/2024	PAC SHARE Program	
Valerie Gonzales		03/01/2024	PAC LeadHERS	
Valerie Gonzales		03/01/2024	Samantha Tapia Formative Endowed Scholarship	
Valerie Gonzales		03/01/2024	PAC SHARE Program	
Erron Y. Gonzalez		03/01/2024	Bits 'n Bytes PAC	
Erron Y. Gonzalez		03/01/2024	PAC Matching Fund	
Erron Y. Gonzalez		03/01/2024	Taylor & Ronda Chandler Math & Sciences Endowed Scholarship	
Evelyn Gonzalez		03/01/2024	PAC LeadHERS	
Evelyn Gonzalez		03/01/2024	PAC SHARE Program	
Jerardo Gonzalez		03/01/2024	Student Emergency Fund	
Sheyla Gonzalez		03/01/2024	Nighthawk Nest Program	
Naydeen T. Gonzalez-De Jesus		03/01/2024	Interim Scholarship	
Barbara Gonzalez-Falla		03/21/2024	Mosaico AlamoPROMISE Event	
Jose Gonzalez-Falla		03/21/2024	Mosaico AlamoPROMISE Event	
Antonio Gonzalez-Martinez		03/04/2024	Masters Leadership Program (MLP) Scholarship	
Amanda M. Gorrell		03/01/2024	General NVC Scholarship	
Amanda M. Gorrell		03/01/2024	Vista Food Pantry	
Karen D. Gottfried		03/01/2024	Student Emergency Fund	
Barbara S. Govan		03/01/2024	SPC Nursing Education Department Faculty Memoriam Scholarship	
Scott Gray		03/04/2024	Masters Leadership Program (MLP) Scholarship	
Scott Gray		03/22/2024	Masters Leadership Program (MLP) Scholarship	
Carla P. Greszler-Gomez		03/01/2024	General NVC Scholarship	
Carla P. Greszler-Gomez		03/01/2024	San Antonio peaceCENTER	
Tywain Griffen		03/01/2024	Dr. Adena Williams Loston Presidential Scholarship	
Michael Grillo		03/01/2024	Clarence Norris Endowed Scholarship	
Michael Grillo		03/01/2024	Dr. Adena Williams Loston Presidential Scholarship	
Leonardo M. Guajardo		03/01/2024	Employee Benevolence Fund	
Barbara R. Guerra		03/01/2024	Psychology Department Scholarship	
Geraldo R. Guerra		03/01/2024	Men Empowerment Network (MEN) Scholarship	
Gloria M. Guerra		03/01/2024	SPC Alumni Association Scholarship	
Gloria M. Guerra		03/01/2024	Artemisia Bowden Memorial Endowed Scholarship	
Gloria M. Guerra		03/01/2024	Dr. Adena Williams Loston Presidential Scholarship	
Javier A. Guerra		03/01/2024	Debra A. Morgan Endowed Scholarship	
Javier A. Guerra		03/01/2024	General NVC Scholarship	
Yalitza P. Guerra		03/01/2024	San Antonio peaceCENTER	
Monica P. Guerrero		03/01/2024	Community of Automotive Professionals	
Russell Guerrero		03/01/2024	Empowerment Center Program	
Brenda M. Guerrero Juarez		03/01/2024	Student Emergency Fund	
Victor Gutierrez		03/01/2024	Golf Tournament SPC	
Ernesto Guzman		03/01/2024	General NVC Scholarship	
Ernesto Guzman		03/01/2024	Jane Moser Drum Encouragement Endowment Program	
Ernesto Guzman		03/01/2024	San Antonio peaceCENTER	
Ernesto Guzman		03/01/2024	Vista Food Pantry	
Monica M. Guzman		03/01/2024	General SPC Scholarship	
Monica M. Guzman		03/01/2024	Jessica's Project	
Matthew Hadden		03/19/2024	NVC Personal Fitness Training Scholarship	
Marsha P. Hall		03/01/2024	Artemisia Bowden Memorial Endowed Scholarship	
Marsha P. Hall		03/01/2024	President's Unrestricted SPC	
Marsha P. Hall		03/01/2024	Safe S.P.A.C.E. (Supporting People through Advocacy, Care and Equity)	
W. W. Hall		03/05/2024	Mosaico AlamoPROMISE Event	
Sabrina I. Hammel		03/01/2024	Dr. Veronica R. Garcia President's Leadership Scholarship	
Sabrina I. Hammel		03/01/2024	Faculty Endowment Scholarship	
Sabrina I. Hammel		03/01/2024	General NLC Scholarship	
Sabrina I. Hammel		03/01/2024	Nighthawk Nest Program	
Sabrina I. Hammel		03/01/2024	NLC President Cares Unrestricted Fund	
Lacy Hampton		03/01/2024	Artemisia Bowden Memorial Endowed Scholarship	
Lacy Hampton		03/01/2024	Clarence Norris Endowed Scholarship	
Lacy Hampton		03/01/2024	Dr. Adena Williams Loston Presidential Scholarship	
Lacy Hampton		03/01/2024	Golf Tournament SPC	
Blair L. Hannon		03/01/2024	Dr. Adena Williams Loston Presidential Scholarship	
Mandy C. Hanz		03/01/2024	Student Emergency Fund	
Caroline V. Haring		03/01/2024	PAC SHARE Program	
Kenneth E. Harris		03/01/2024	PAC SHARE Program	
Anonymous		03/01/2024	James B. Riley Formative Endowed Scholarship	
Anonymous		03/01/2024	PAC LeadHERS	
Anonymous		03/01/2024	Samantha Tapia Formative Endowed Scholarship	
Anonymous		03/01/2024	PAC SHARE Program	

Donor Name	Soft Credit Recipient Name	Gift Date	Fund Description	Honor / Memorial Name
Christopher R. Harrison		03/01/2024	Vista Food Pantry	
Aileen M. Hartfield		03/01/2024	Artemisia Bowden Memorial Endowed Scholarship	
Aileen M. Hartfield		03/01/2024	Dr. Adena Williams Loston Presidential Scholarship	
Aileen M. Hartfield		03/01/2024	General SPC Scholarship	
Shawn W. Harward		03/01/2024	General NVC Scholarship	
Shawn W. Harward		03/01/2024	San Antonio peaceCENTER	
Shawn W. Harward		03/01/2024	Vista Food Pantry	
Teri A. Haye		03/01/2024	Artemisia Bowden Memorial Endowed Scholarship	
Gertrude M. Heard		03/01/2024	Artemisia Bowden Memorial Endowed Scholarship	
Gertrude M. Heard		03/01/2024	Dr. Adena Williams Loston Presidential Scholarship	
Alejandro Hernandez		03/01/2024	Employee Benevolence Fund	
Claudia E. Hernandez		03/01/2024	Employee Benevolence Fund	
Denise Hernandez		03/21/2024	Mosaico AlamoPROMISE Event	
Gloria P. Hernandez		03/01/2024	Allan J. Lavelle & Toni Villarreal Music Scholarship	
Hector M. Hernandez		03/01/2024	AlamoPROMISE Endowment Scholarship	
Hector M. Hernandez		03/01/2024	Annual Fund	
Hector M. Hernandez		03/01/2024	Employee Benevolence Fund	
Hector M. Hernandez		03/01/2024	General Foundation Scholarship Fund	
Hector M. Hernandez		03/01/2024	Student Emergency Fund	
Marilyn Hernandez		03/01/2024	PAC Alumni & Friends	
Marilyn Hernandez		03/01/2024	PAC LeadHERS	
Marilyn Hernandez		03/01/2024	Samantha Tapia Formative Endowed Scholarship	
Olivia Hernandez		03/01/2024	General SPC Scholarship	
Sunny R. Hernandez		03/01/2024	General SPC Scholarship	
Cynthia D. Hernandez-Guerra		03/01/2024	Men Empowerment Network (MEN) Scholarship	
Delicia M. Herrera		03/01/2024	Eastside Education and Training Center Program Support	
Pamela L. Herrington-Moriarty		03/01/2024	Employee Benevolence Fund	
Pamela L. Herrington-Moriarty		03/01/2024	Student Emergency Fund	
Diane C. Hester		03/01/2024	Safe S.P.A.C.E. (Supporting People through Advocacy, Care and Equity)	
Phillip L. Hicks		03/01/2024	General NLC Scholarship	
Phillip L. Hicks		03/01/2024	Nighthawk Nest Program	
Hilary R. Hilario		03/01/2024	PAC LeadHERS	
Carolyn J. Hilton		03/01/2024	Rea & Barbara Hinrichs Endowed Scholarship	
Robert R. Hines		03/01/2024	PAC SHARE Program	
Lawrence Holley		03/01/2024	Student Emergency Fund	
Catherine Hornberger		03/26/2024	Mosaico AlamoPROMISE Event	
Howard Technology Solutions		03/13/2024	Mosaico AlamoPROMISE Event	
Henry K. Howerton		03/04/2024	KSYM Program	
Jennifer R. Huebenthal		03/01/2024	PAC SHARE Program	
Jennifer R. Huebenthal		03/01/2024	Upward Bound Bridge Scholarship	
Jessica Humann		03/01/2024	Samantha Tapia Formative Endowed Scholarship	
Jessica Humann		03/01/2024	PAC SHARE Program	
Jessica Humann		03/01/2024	Taylor & Ronda Chandler Math & Sciences Endowed Scholarship	
Laurilyn Humberson		03/01/2024	General SPC Scholarship	
Matthew C. Hunker		03/01/2024	AlamoPROMISE Endowment Scholarship	
Anonymous		03/01/2024	David E Mrizek Endowed Scholarship Fund	
Anonymous		03/01/2024	Ron Lucke Speech & Drama Scholarship	
Warren Hurd		03/01/2024	Dr. Veronica R. Garcia President's Leadership Scholarship	
Warren Hurd		03/01/2024	General NLC Scholarship	
Melissa Huron Mejia		03/01/2024	PAC LeadHERS	
Melissa Huron Mejia		03/01/2024	PAC SHARE Program	
Rebecca Hutchison		03/21/2024	Mosaico AlamoPROMISE Event	
Leticia C. Inocencio		03/01/2024	PAC LeadHERS	
Leticia C. Inocencio		03/01/2024	PAC SHARE Program	
Anonymous		03/01/2024	Dr. Adena Williams Loston Presidential Scholarship	
Ann R. Islas		03/01/2024	Annual Fund	
Ann R. Islas		03/01/2024	Student Emergency Fund	
Gregory J-Douglas		03/20/2024	Masters Leadership Program (MLP) Scholarship	
Adrian Jackson		03/01/2024	Interim Scholarship	
Robert James		03/01/2024	General Foundation Scholarship Fund	
Rachara A. Jefferson		03/01/2024	PAC LeadHERS	
Rachara A. Jefferson		03/01/2024	President's Unrestricted PAC	
Rachara A. Jefferson		03/01/2024	Samantha Tapia Formative Endowed Scholarship	
Rachara A. Jefferson		03/01/2024	PAC SHARE Program	
Lawson Jesse		03/21/2024	Mosaico AlamoPROMISE Event	
Gloria S. John		03/01/2024	Pay It Forward Scholarship	
David E. Johnson		03/22/2024	Annual Fund	
George H. Johnson		03/01/2024	President's Unrestricted SPC	
Matt Johnson		03/21/2024	Mosaico AlamoPROMISE Event	
Robert B. Jones		03/01/2024	General Foundation Scholarship Fund	
Sarah S. Jones		03/01/2024	SAC Honors Academy	
Sarah S. Jones		03/01/2024	SAC Mexican American Studies (MAS) Program	
Sarah S. Jones		03/01/2024	President's Unrestricted SAC	
Sarah S. Jones		03/01/2024	SAC Student Support Fund	
Timothy A. Jones		03/01/2024	NVC Fine & Performing Arts Endowed Scholarship	
Jeena Joseph		03/01/2024	President's Unrestricted PAC	
Allison Joubert		03/01/2024	President's Unrestricted SPC	
Andrew S. Joyce		03/01/2024	James B. Riley Formative Endowed Scholarship	
Andrew S. Joyce		03/01/2024	PAC LeadHERS	
Andrew S. Joyce		03/01/2024	President's Unrestricted PAC	
Andrew S. Joyce		03/01/2024	Samantha Tapia Formative Endowed Scholarship	
Andrew S. Joyce		03/01/2024	PAC SHARE Program	
Karla P. Juarez		03/01/2024	Child Care Center	
Anonymous		03/12/2024	General Foundation Scholarship Fund	
Christine M. Kalcso-Aten		03/01/2024	OCI Solar Power Program	
Christine M. Kalcso-Aten		03/01/2024	PNC Small Business & Entrepreneurship Program	
Anonymous		03/01/2024	Artemisia Bowden Memorial Endowed Scholarship	
Darcy A. Keene		03/01/2024	Annual Fund	
Lynn Kelly		03/21/2024	Mosaico AlamoPROMISE Event	
Diana C. Kersey		03/01/2024	Vista Food Pantry	
Diana C. Kersey		03/01/2024	NVC Fine and Performing Arts Student Support Program Fund	
Julie Kirkland-Poirier		03/01/2024	NLC President Cares Unrestricted Fund	
Kenneth Kist		03/04/2024	AlamoPROMISE Endowment Scholarship	
KKW Donaldson LLC		03/08/2024	Golf Tournament SPC	
Jeffrey W. Koch		03/01/2024	Ag Capital Campaign Fund Request	
Deborah Koeck		03/01/2024	President's Unrestricted PAC	
Todd A. Kopas		03/01/2024	Student Emergency Fund	

Donor Name	Soft Credit Recipient Name	Gift Date	Fund Description	Honor / Memorial Name
Jamie Kowalski		03/21/2024	Mosaico AlamoPROMISE Event	
Anne Krause		03/22/2024	AlamoPROMISE Endowment Scholarship	Michael Beldon, Louise Beldon
Conrad D. Krueger		03/01/2024	General SAC Scholarship	
Sheryl A. Ksenich		03/01/2024	Artemisia Bowden Memorial Endowed Scholarship	
Sheryl A. Ksenich		03/01/2024	Dr. Adena Williams Loston Presidential Scholarship	
Sheryl A. Ksenich		03/01/2024	General SPC Scholarship	
Anna M. Kuwamura		03/01/2024	Student Emergency Fund	
Caroline Kuyumcuoglu		03/01/2024	General NVC Scholarship	
Caroline Kuyumcuoglu		03/01/2024	San Antonio peaceCENTER	
Caroline Kuyumcuoglu		03/01/2024	Vista Food Pantry	
Kym's Angels		03/04/2024	Mosaico AlamoPROMISE Event	
Patricia A. Lamson		03/01/2024	Dr. Adena Williams Loston Presidential Scholarship	
Langley & Banack, Inc.		03/29/2024	Golf Tournament SPC	
George R. Laughhead		03/01/2024	Annual Fund	
Wesley B. Lay		03/01/2024	Black Student Alliance Scholarship	
Wesley B. Lay		03/01/2024	Dr. Adena Williams Loston Presidential Scholarship	
Marquette Leach		03/01/2024	Vista Food Pantry	
Paul B. Lede		03/01/2024	President's Unrestricted SPC	
Isaiah Ledesma		03/01/2024	General SPC Scholarship	
Julian Ledesma		03/01/2024	AlamoPROMISE Endowment Scholarship	
Linda D. Lee		03/01/2024	Joe & Josie Garcia Scholarship	
Minkyung Lee		03/01/2024	NVC Fans General Support	
Patrick R. Lee		03/01/2024	PAC SHARE Program	
Judah M. Leggett		03/01/2024	Faculty Endowment Scholarship	
Judah M. Leggett		03/01/2024	Nighthawk Nest Program	
Carolina Lewis		03/21/2024	Mosaico AlamoPROMISE Event	
Neil E. Lewis		03/01/2024	San Antonio peaceCENTER	
Christina M. Licea		03/01/2024	Samantha Tapia Formative Endowed Scholarship	
Christina M. Licea		03/01/2024	PAC SHARE Program	
Kirk Linhart-Kistner		03/21/2024	Mosaico AlamoPROMISE Event	
Terrence Littlefield		03/01/2024	SPC Alumni Association Scholarship	
Terrence Littlefield		03/01/2024	Artemisia Bowden Memorial Endowed Scholarship	
Terrence Littlefield		03/01/2024	Dr. Adena Williams Loston Presidential Scholarship	
Gina M. Lopez		03/01/2024	AlamoPROMISE Endowment Scholarship	
Hermelind Lopez		03/01/2024	SAC Student Support Fund	
Jessica A. Lopez		03/01/2024	General SPC Scholarship	
Kristina S. Lopez		03/01/2024	Child Care Center	
Kristina S. Lopez		03/01/2024	General SAC Scholarship	
Kristina S. Lopez		03/01/2024	Pay It Forward Scholarship	
Nidia C. Lopez		03/01/2024	PAC LeadHERS	
Nidia C. Lopez		03/01/2024	PAC SHARE Program	
Priscilla P. Lopez		03/01/2024	Samantha Tapia Formative Endowed Scholarship	
Priscilla P. Lopez		03/01/2024	PAC SHARE Program	
Rudolph R. Lopez		03/01/2024	Student Emergency Fund	
Yvette Lopez		03/01/2024	DREAMers Scholarship	
Yvette Lopez		03/01/2024	Student Emergency Fund	
Yvette Lopez		03/01/2024	Artemisia Bowden Memorial Endowed Scholarship	
Yvette Lopez		03/01/2024	Dr. Adena Williams Loston Presidential Scholarship	
Yvette Lopez		03/01/2024	General SPC Scholarship	
Javier Lopez de Obeso		03/27/2024	General Foundation Scholarship Fund	
Elizabeth Lorenz		03/21/2024	Mosaico AlamoPROMISE Event	
Adena W. Loston		03/01/2024	Dr. Adena Williams Loston Presidential Scholarship	
Stella Lovato		03/01/2024	ECO-Centro Program	
Stella Lovato		03/01/2024	Scobee Education Center Programs	
Stella Lovato		03/01/2024	SAC Student Support Fund	
Felicia T. Love		03/01/2024	Student Emergency Fund	
Felicia T. Love		03/01/2024	Nighthawk Nest Program	
Felicia T. Love		03/01/2024	Vista Food Pantry	
Felicia T. Love		03/01/2024	PAC SHARE Program	
Felicia T. Love		03/01/2024	SAC Student Support Fund	
Felicia T. Love		03/01/2024	Safe S.P.A.C.E. (Supporting People through Advocacy, Care and Equity)	
Ricardo H. Lowe		03/01/2024	AlamoPROMISE Endowment Scholarship	
Ricardo H. Lowe		03/01/2024	Annual Fund	
Ricardo H. Lowe		03/01/2024	Employee Benevolence Fund	
Ricardo H. Lowe		03/01/2024	General Foundation Scholarship Fund	
Ricardo H. Lowe		03/01/2024	Student Emergency Fund	
Ricardo H. Lowe		03/01/2024	Empowerment Center Program	
Ricardo H. Lowe		03/01/2024	General SAC Scholarship	
Ricardo H. Lowe		03/01/2024	President's Unrestricted SAC	
Ricardo H. Lowe		03/01/2024	Seats of Support Program Support Fund	
Ricardo H. Lowe		03/01/2024	SAC Student Support Fund	
James Lowery		03/04/2024	Jack Stone Award for New Music	
Jeremy R. Lozano		03/01/2024	Vista Food Pantry	
Donald R. Lucas		03/01/2024	Tailor Kai Matthews Memorial Scholarship	
Jacqueline Lucero		03/01/2024	Annual Fund	
Jacqueline Lucero		03/01/2024	Employee Benevolence Fund	
Jacqueline Lucero		03/01/2024	Student Emergency Fund	
Alexandro M. Luna		03/01/2024	PAC SHARE Program	
Robin L. Lund		03/01/2024	NVC Alumni Association Scholarship	
Robin L. Lund		03/01/2024	General NVC Scholarship	
Robin L. Lund		03/01/2024	Jane Moser Drum Encouragement Endowment Program	
Robin L. Lund		03/01/2024	San Antonio peaceCENTER	
Robin L. Lund		03/01/2024	Vista Food Pantry	
Caroline Mains		03/01/2024	President's Unrestricted PAC	
Caroline Mains		03/01/2024	PAC SHARE Program	
Merasol M. Malapo		03/01/2024	Annual Fund	
Christopher M. Maldonado		03/01/2024	Employee Benevolence Fund	
Gerald F. Manahan		03/01/2024	Gerald Manahan Student Supplies Program Fund	
David Mancha		03/01/2024	James B. Riley Formative Endowed Scholarship	
David Mancha		03/01/2024	PAC LeadHERS	
David Mancha		03/01/2024	Samantha Tapia Formative Endowed Scholarship	
David Mancha		03/01/2024	PAC SHARE Program	
Sara Mann		03/01/2024	AlamoPROMISE Endowment Scholarship	
Sara Mann		03/01/2024	Annual Fund	
Loretta B. Manning		03/01/2024	Debra A. Morgan Endowed Scholarship	
Loretta B. Manning		03/01/2024	Janet H. Rangel Memorial Scholarship	
Robert G. Marbut		03/01/2024	Robert G. Marbut Jr Endowed Scholarship	

Donor Name	Soft Credit Recipient Name	Gift Date	Fund Description	Honor / Memorial Name
Jonathan R. Marin		03/01/2024	Annual Fund	
Jonathan R. Marin		03/01/2024	Employee Benevolence Fund	
Jonathan R. Marin		03/01/2024	General Foundation Scholarship Fund	
Jonathan R. Marin		03/01/2024	Student Emergency Fund	
Viviane Marioneaux-Maguire		03/01/2024	Debra A. Morgan Endowed Scholarship	
Viviane Marioneaux-Maguire		03/01/2024	NVC Digital Media Student Program Support	
Mary M. Martowe		03/01/2024	Dr. Jacqueline Claunch Legacy Endowed Formative Scholarship	
Mary M. Martowe		03/01/2024	Fine Arts Endowment Programming	
Mary M. Martowe		03/01/2024	Reserve Your Seat	
Mary M. Martowe		03/01/2024	San Antonio peaceCENTER	
Delilah L. Marquez		03/01/2024	PAC LeadHERS	
Delilah L. Marquez		03/01/2024	Samantha Tapia Formative Endowed Scholarship	
Delilah L. Marquez		03/01/2024	PAC SHARE Program	
Deborah M. Martin		03/01/2024	General Foundation Scholarship Fund	
Deborah M. Martin		03/01/2024	Generat NLC Scholarship	
Deborah M. Martin		03/01/2024	Vista Food Pantry	
Deborah M. Martin		03/01/2024	General PAC Scholarship	
Deborah M. Martin		03/01/2024	ECO-Centro Program	
Deborah M. Martin		03/01/2024	General SPC Scholarship	
Louisa P. Martin		03/01/2024	AlamoPROMISE Endowment Scholarship	
Louisa P. Martin		03/01/2024	Annual Fund	
Cesar Martinez		03/01/2024	Artemisia Bowden Memorial Endowed Scholarship	
Connie M. Martinez		03/01/2024	President's Unrestricted PAC	
Debra A. Martinez		03/01/2024	Joe & Josie Garcia Scholarship	
Jocelyn A. Martinez		03/01/2024	PAC LeadHERS	
Jocelyn A. Martinez		03/01/2024	PAC SHARE Program	
Louis E. Martinez		03/01/2024	PAC SHARE Program	
Luis C. Martinez		03/01/2024	Student Emergency Fund	
Paul G. Martinez		03/01/2024	Beverly Evans Memorial NVC Student Live Scholarship	
Rachell L. Martinez		03/01/2024	PAC Journalism/Mass Communications Program	
Rachell L. Martinez		03/01/2024	Palo Alto Alumni Y Amigos Association Scholarship	
Rosita I. Martinez		03/01/2024	AlamoPROMISE Endowment Scholarship	
Rosita I. Martinez		03/01/2024	Annual Fund	
Rosita I. Martinez		03/01/2024	Student Emergency Fund	
Valerie Martinez		03/01/2024	General NVC Scholarship	
Victoria N. Martinez		03/01/2024	Vista Food Pantry	
Robert May		03/08/2024	Jack Stone Award for New Music	
Sarah B. May		03/01/2024	Jack Stone Award for New Music	
Lisa Mazure		03/01/2024	AlamoPROMISE Endowment Scholarship	
Lisa Mazure		03/01/2024	General Foundation Scholarship Fund	
Lisa Mazure		03/01/2024	Student Emergency Fund	
Lisa Mazure		03/21/2024	Mosaico AlamoPROMISE Event	
Lisa Mazure		03/21/2024	Mosaico AlamoPROMISE Event	
Paula L. Mc Kenna		03/01/2024	Dr. Said Fariabi Memorial Endowed Scholarship	
Sam H. McCall		03/01/2024	SPC Alumni Association Scholarship	
Sam H. McCall		03/01/2024	Artemisia Bowden Memorial Endowed Scholarship	
Sam H. McCall		03/01/2024	Clarence Norris Endowed Scholarship	
Sam H. McCall		03/01/2024	Dr. Adena Williams Loston Presidential Scholarship	
Sam H. McCall		03/01/2024	General SPC Scholarship	
Thomas N. McCrary		03/01/2024	James C. Elmore II Memorial Art Scholarship	
Diana McCurtain-Talbert		03/01/2024	AlamoPROMISE Endowment Scholarship	
Diana McCurtain-Talbert		03/01/2024	NVC Personal Fitness Training Scholarship	
Lisa K. McDaniel		03/01/2024	Ashley Lynn Degerstrom Endowed Scholarship	
Lisa K. McDaniel		03/01/2024	NVC Broadcast Media Program	
Jasmine T. McDonald		03/01/2024	SAC Student Support Fund	
Paula McGee	David McGee	03/13/2024	Florence J Penrod Endowed Nursing Scholarship Formative 3/14/27	Florence J. Penrod
Kari McKay		03/01/2024	General NVC Scholarship	
Kari McKay		03/01/2024	San Antonio peaceCENTER	
Milton R. McManigle		03/01/2024	General NVC Scholarship	
Fiona M. McWilliam		03/01/2024	Faculty Senate Endowed Scholarship	
Fiona M. McWilliam		03/01/2024	General NVC Scholarship	
Fiona M. McWilliam		03/01/2024	Vista Food Pantry	
Vanessa M. Meador		03/01/2024	General SPC Scholarship	
Gina L. Mealey		03/01/2024	Faculty Endowment Scholarship	
Melissa J. Medellin		03/01/2024	Student Emergency Fund	
Melissa J. Medellin		03/01/2024	First Responders Academy-Formative Endowment	
Sylvia G. Medina		03/01/2024	Kendra Ann Ward Music Endowed Scholarship	
Jennifer L. Mejia		03/01/2024	PAC LeadHERS	
Jennifer L. Mejia		03/01/2024	PAC SHARE Program	
Shawn S. Melendes		03/01/2024	James B. Riley Formative Endowed Scholarship	
Shawn S. Melendes		03/01/2024	PAC LeadHERS	
Shawn S. Melendes		03/01/2024	President's Unrestricted PAC	
Shawn S. Melendes		03/01/2024	Samantha Tapia Formative Endowed Scholarship	
Shawn S. Melendes		03/01/2024	PAC SHARE Program	
Jade P. Mendoza		03/01/2024	Student Emergency Fund	
Christopher H. Metsgar		03/01/2024	Interim Scholarship	
Erica N. Meza		03/01/2024	AlamoPROMISE Endowment Scholarship	
Erica N. Meza		03/01/2024	Student Emergency Fund	
Stephen D. Minor		03/01/2024	AlamoPROMISE Endowment Scholarship	
Jamie C. Miranda		03/01/2024	General SPC Scholarship	
Maria M. Miranda Flores		03/01/2024	Annual Fund	
Eric Mitchell		03/18/2024	Masters Leadership Program (MLP) Scholarship	
Joy R. Moczygemba		03/01/2024	Nighthawk Nest Program	
Victoria L. Moe		03/01/2024	SAC Student Support Fund	
Roberta V. Moglia		03/01/2024	SAC Student Support Fund	
Sitakata Mohanty		03/01/2024	President's Unrestricted SAC	
Valerie Y. Moke		03/01/2024	SPC Nursing Education Department Faculty Memoriam Scholarship	
Robert B. Molina		03/01/2024	SAC Student Support Fund	
Suzel M. Molina		03/01/2024	PAC LeadHERS	
Timothy C. Molina		03/01/2024	General NVC Scholarship	
Anonymous		03/01/2024	General Foundation Scholarship Fund	
Melissa Monroe-Young		03/01/2024	Bellinger-Coleman Black Media Scholarship	
Steven Montemayor		03/01/2024	Vista Food Pantry	
Elizabeth H. Montgomery		03/01/2024	PAC LeadHERS	
Elizabeth H. Montgomery		03/01/2024	PAC SHARE Program	
Elizabeth H. Montgomery		03/01/2024	Taylor & Ronda Chandler Math & Sciences Endowed Scholarship	
Adam R. Moore		03/01/2024	General SPC Scholarship	

Donor Name	Soft Credit Recipient Name	Gift Date	Fund Description	Honor / Memorial Name
Julie E. Moore-Felux		03/01/2024	San Antonio peaceCENTER	
Anonymous		03/01/2024	AlamoPROMISE Endowment Scholarship	
Anonymous		03/01/2024	Employee Benevolence Fund	
Anonymous		03/01/2024	General Foundation Scholarship Fund	
Anonymous		03/01/2024	Student Emergency Fund	
Joshua H. Moran		03/01/2024	AlamoPROMISE Endowment Scholarship	
Joshua H. Moran		03/01/2024	Annual Fund	
Joshua H. Moran		03/01/2024	Vista Food Pantry	
Joshua H. Moran		03/01/2024	David & Diane Lerma Endowed Scholarship Corpus	
Joshua H. Moran		03/01/2024	Phi Theta Kappa Food Pantry	
Andrina A. Moreno		03/01/2024	AlamoPROMISE Endowment Scholarship	
Kerri M. Morgan		03/01/2024	Friends of Music at San Antonio College Scholarship	
Morgan Stanley	Juan Reyna	03/01/2024	Joseph M. Tarin Scholarship	
Sammi M. Morrill		03/01/2024	Eastside Education and Training Center Program Support	
Kelley D. Morris-Wright		03/01/2024	AlamoPROMISE Endowment Scholarship	
Kelley D. Morris-Wright		03/01/2024	Student Emergency Fund	
William L. Moseley		03/01/2024	President's Unrestricted SPC	
Zaina Mukhtar		03/01/2024	Employee Benevolence Fund	
Sean P. Mullen		03/01/2024	Annual Fund	
Dorothy J. Mundine		03/01/2024	Annual Fund	
Minerva Muniz		03/01/2024	Beverly Evans Memorial NVC Student Live Scholarship	
Minerva Muniz		03/01/2024	MAS Scholarship	
Minerva Muniz		03/01/2024	San Antonio peaceCENTER	
Minerva Muniz		03/01/2024	Vista Food Pantry	
Cynthia Munoz		03/21/2024	Mosaico AlamoPROMISE Event	
John Munoz		03/01/2024	Artemisia Bowden Memorial Endowed Scholarship	
Mandy A. Munoz		03/01/2024	PAC Adult Learning Academy GED Scholarship	
Mandy A. Munoz		03/01/2024	PAC LeadHERS	
Mandy A. Munoz		03/01/2024	PAC SHARE Program	
Anonymous		03/01/2024	Dr. Elizabeth Garza Memorial Endowed Scholarship	
Thomas Y. Murguia		03/01/2024	Raul S. Murguia Presidential Honors Endowed Scholarship	
Paul Myers		03/27/2024	Jack Stone Award for New Music	
Prakash N. Nair		03/01/2024	General NVC Scholarship	
Edgar E. Nandin		03/01/2024	GED Empowerment to College Endowed Scholarship	
Edgar E. Nandin		03/01/2024	Samantha Tapia Formative Endowed Scholarship	
Edgar E. Nandin		03/01/2024	PAC SHARE Program	
Esmeralda G. Nandin		03/01/2024	President's Unrestricted SAC	
Monica A. Neal		03/01/2024	PAC LeadHERS	
Monica A. Neal		03/01/2024	PAC SHARE Program	
Virginia M. Nelms		03/01/2024	Taylor & Ronda Chandler Math & Sciences Endowed Scholarship	
Nelson Interiors, LLC		03/15/2024	PAC Fest	
Solomon K. Nfor		03/01/2024	Jessica's Project	
Lori Nicholas		03/01/2024	NVC Alumni Program Support	
Lori Nicholas		03/01/2024	Vista Food Pantry	
James Nortey		03/21/2024	Mosaico AlamoPROMISE Event	
Paul J. Northway		03/01/2024	Vista Food Pantry	
Rhonda M. O'Cana		03/01/2024	Samantha Tapia Formative Endowed Scholarship	
Rhonda M. O'Cana		03/01/2024	PAC SHARE Program	
O'Connell Robertson		03/01/2024	Golf Tournament SPC	
O'Connell Robertson		03/13/2024	Mosaico AlamoPROMISE Event	
Ryan R. Obaya		03/01/2024	PAC SHARE Program	
Maria Catherine A. Obien		03/01/2024	AlamoPROMISE Endowment Scholarship	
Maria Catherine A. Obien		03/01/2024	Annual Fund	
Maria Catherine A. Obien		03/01/2024	Debra A. Morgan Endowed Scholarship	
David D. Ochoa		03/21/2024	President's Unrestricted PAC	
Sofia M. Ongay		03/01/2024	AlamoPROMISE Endowment Scholarship	
Vanessa A. Onofre-Chavarria		03/01/2024	AlamoPROMISE Endowment Scholarship	
Vanessa A. Onofre-Chavarria		03/01/2024	Employee Benevolence Fund	
Vanessa A. Onofre-Chavarria		03/01/2024	Janet H. Rangel Memorial Scholarship	
Vanessa A. Onofre-Chavarria		03/01/2024	Student Emergency Fund	
Juan M. Oretga		03/01/2024	Kendra Ann Ward Music Endowed Scholarship	
Juan M. Oretga		03/01/2024	President's Unrestricted SAC	
Stephanie D. Ornelas		03/01/2024	PAC SHARE Program	
John Orona		03/01/2024	Dr. Adena Williams Loston Presidential Scholarship	
John Orona		03/01/2024	General SPC Scholarship	
Adam O. Orscozodriguez		03/01/2024	Samantha Tapia Formative Endowed Scholarship	
Anonymous		03/01/2024	General SPC Scholarship	
Jennifer O. Ortega		03/01/2024	Ray Hernandez FORMATIVE Endowed Scholarship	
Petra R. Ortega		03/01/2024	General NVC Scholarship	
Petra R. Ortega		03/01/2024	San Antonio peaceCENTER	
Petra R. Ortega		03/01/2024	Vista Food Pantry	
Lorissa A. Ortiz		03/01/2024	PAC SHARE Program	
Maria M. Ortiz		03/01/2024	PAC LeadHERS	
Maria M. Ortiz		03/01/2024	PAC SHARE Program	
Paulina H. Ortiz		03/01/2024	Janet H. Rangel Memorial Scholarship	
Paulina H. Ortiz		03/01/2024	Ruben P. Flores Endowed Scholarship	
Paulina H. Ortiz		03/01/2024	PAC SHARE Program	
Rita L. Ortiz		03/01/2024	PAC SHARE Program	
Rosalinda Ortiz		03/01/2024	PAC LeadHERS	
Rosalinda Ortiz		03/01/2024	President's Unrestricted PAC	
Rosalinda Ortiz		03/01/2024	Samantha Tapia Formative Endowed Scholarship	
Rosalinda Ortiz		03/01/2024	PAC SHARE Program	
Jocelyn A. Ozuna Gunnels		03/19/2024	OZUNA LRC Children's Library	George G. Ozuna
Blanca E. Padilla		03/01/2024	AlamoPROMISE Endowment Scholarship	
Blanca E. Padilla		03/01/2024	Artemisia Bowden Memorial Endowed Scholarship	
Anonymous		03/01/2024	NVC Endowed Scholarship for Business Students	
Jennifer M. Parrott		03/01/2024	General NLC Scholarship	
Sara Passement		03/01/2024	SAC Student Support Fund	
Pat & Tom Frost Foundation		03/19/2024	AlamoPROMISE Endowment Scholarship	
Amy C. Pena		03/01/2024	SAC Student Support Fund	
Dora Pena		03/01/2024	Empowerment Center Program	
Dora Pena		03/01/2024	General SAC Scholarship	
Dora Pena		03/01/2024	President's Unrestricted SAC	
Dora Pena		03/01/2024	Seats of Support Program Support Fund	
Dora Pena		03/01/2024	SAC Student Support Fund	
Karina G. Pena		03/01/2024	Employee Benevolence Fund	
Manuel J. Pena		03/01/2024	Student Emergency Fund	

Donor Name	Soft Credit Recipient Name	Gift Date	Fund Description	Honor / Memorial Name
Amy S. Peppersack		03/01/2024	Empowerment Center Program	
Amy S. Peppersack		03/01/2024	General SAC Scholarship	
Amy S. Peppersack		03/01/2024	President's Unrestricted SAC	
Amy S. Peppersack		03/01/2024	SAC Student Support Fund	
Jose Perates		03/01/2024	G.A.L.A. (Gay & Lesbian Association) Scholarship	
Jose Perates		03/01/2024	Rea & Barbara Hinrichs Endowed Scholarship	
Antony Perez		03/01/2024	President's Unrestricted SAC	
Raquel Perez		03/01/2024	Student Emergency Fund	
Anonymous		03/01/2024	Dr. Veronica R. Garcia President's Leadership Scholarship	
Anonymous		03/01/2024	Faculty Endowment Scholarship	
Anonymous		03/01/2024	Nighthawk Nest Program	
Anonymous		03/01/2024	NLC President Cares Unrestricted Fund	
David Perry		03/04/2024	Masters Leadership Program (MLP) Scholarship	
Johnathan Peterson		03/01/2024	PAC SHARE Program	
Linda H. Peterson		03/01/2024	Ken Veatch DPMA Scholarship	
Wayne E. Peterson		03/01/2024	Vista Food Pantry	
Catherine Phillips		03/01/2024	DREAMers Scholarship	
Catherine Phillips		03/01/2024	Psychology Department Scholarship	
Michelle M. Pietri		03/01/2024	Vista Food Pantry	
Anonymous		03/21/2024	Mosaico AlamoPROMISE Event	
Kiana A. Pina		03/01/2024	PAC LeadHERS	
Sophia E. Pina		03/01/2024	Vista Food Pantry	
Tashina E. Pina		03/01/2024	Eastside Education and Training Center Program Support	
James J. Pobanz		03/01/2024	General SAC Scholarship	
Nakia Pope		03/01/2024	Ethics Scholarship	
Nakia Pope		03/01/2024	Faculty Senate Endowed Scholarship	
Nakia Pope		03/01/2024	General NVC Scholarship	
Nakia Pope		03/01/2024	NVC Compassion (President's Unrestricted Fund)	
Nakia Pope		03/01/2024	San Antonio peaceCENTER	
Nakia Pope		03/01/2024	Vista Food Pantry	
Lillian R. Porter		03/01/2024	Employee Benevolence Fund	
Anetia L. Ports		03/01/2024	Faculty Endowment Scholarship	
Anetia L. Ports		03/01/2024	General NLC Scholarship	
Anetia L. Ports		03/01/2024	Nighthawk Nest Program	
Anetia L. Ports		03/01/2024	NLC President Cares Unrestricted Fund	
Dawn M. Poses		03/01/2024	PAC SHARE Program	
Daniel T. Powell		03/01/2024	General NVC Scholarship	
Daniel T. Powell		03/01/2024	San Antonio peaceCENTER	
Daniel T. Powell		03/01/2024	Vista Food Pantry	
Thomas G. Pressly		03/01/2024	General NVC Scholarship	
Thomas G. Pressly		03/01/2024	Vista Food Pantry	
Darlene T. Price-Johnson		03/01/2024	Samantha Tapia Formative Endowed Scholarship	
Darlene T. Price-Johnson		03/01/2024	Taylor & Ronda Chandler Math & Sciences Endowed Scholarship	
Darlene T. Price-Johnson		03/01/2024	STEM SPC Scholarship	
Alexis N. Prieto		03/01/2024	Annual Fund	
Ruth G. Prieto		03/01/2024	AlamoPROMISE Endowment Scholarship	
Ruth G. Prieto		03/01/2024	DREAMers Scholarship	
Ruth G. Prieto		03/01/2024	Student Leadership Institute - Employee Giving Scholarship	
Shahneela Qazi		03/01/2024	Student Emergency Fund	
Johnnie J. Quiles		03/01/2024	Artemisia Bowden Memorial Endowed Scholarship	
Johnnie J. Quiles		03/01/2024	Dr. Adena Williams Loston Presidential Scholarship	
Johnnie J. Quiles		03/01/2024	General SPC Scholarship	
Christina Quintanilla		03/01/2024	Annual Fund	
Connie M. Ramirez		03/01/2024	General SPC Scholarship	
Leticia Ramirez		03/01/2024	Annual Fund	
Samantha N. Ramos		03/01/2024	Student Emergency Fund	
Jolinda L. Ramsey		03/01/2024	Ron Lucke Speech & Drama Scholarship	
Randolph Area Rotary Club		03/01/2024	General NLC Scholarship	
Gabriela C. Ranget		03/01/2024	AlamoPROMISE Endowment Scholarship	
Gabriela C. Ranget		03/01/2024	TACHE Scholarship	
Gabriela C. Ranget		03/01/2024	PAC LeadHERS	
Gabriela C. Ranget		03/01/2024	PAC SHARE Program	
Phillip Ray		03/08/2024	Golf Tournament SPC	
John M. Raymond		03/01/2024	Rea & Barbara Hinrichs Endowed Scholarship	
Samantha J. Raymond		03/01/2024	San Antonio peaceCENTER	
Samantha J. Raymond		03/01/2024	Vista Food Pantry	
Scott C. Raymond		03/01/2024	NVC Alumni Association Scholarship	
Scott C. Raymond		03/01/2024	Vista Food Pantry	
Julie A. Razuri		03/01/2024	Rea & Barbara Hinrichs Endowed Scholarship	
Thomas J. Reed		03/01/2024	Samantha Tapia Formative Endowed Scholarship	
Thomas J. Reed		03/01/2024	PAC SHARE Program	
Enida L. Rehome		03/01/2024	Artemisia Bowden Memorial Endowed Scholarship	
Enida L. Rehome		03/01/2024	Dr. Adena Williams Loston Presidential Scholarship	
Enida L. Rehome		03/01/2024	General SPC Scholarship	
Enida L. Rehome		03/01/2024	Golf Tournament SPC	
Steven P. Reyes		03/01/2024	General Foundation Scholarship Fund	
Veronica I. Reyes		03/01/2024	Joe & Josie Garcia Scholarship	
April A. Reyna		03/01/2024	Empowerment Center Program	
April A. Reyna		03/01/2024	SAC Student Support Fund	
Caroline E. Richardson		03/01/2024	Annual Fund	
Caroline E. Richardson		03/01/2024	Interim Scholarship	
Caroline E. Richardson		03/01/2024	Empowerment Center Program	
Caroline E. Richardson		03/01/2024	General SAC Scholarship	
Lucinda M. Rico		03/01/2024	General NVC Scholarship	
Lane Riggs		03/21/2024	Mosaico AlamoPROMISE Event	
Daniel E. Riley		03/01/2024	SPC Alumni Association Scholarship	
Daniel E. Riley		03/01/2024	Artemisia Bowden Memorial Endowed Scholarship	
Daniel E. Riley		03/01/2024	CPS Energy-OCI Solar Power Renewable Energy Scholarship	
Daniel E. Riley		03/01/2024	Tourism, Hospitality, Culinary Arts (THCA) Scholarship	
Cassandra Rincones		03/01/2024	First Responders Academy-Formative Endowment	
Cassandra Rincones		03/01/2024	SAC Mexican American Studies (MAS) Program	
Jose O. Rios		03/01/2024	AlamoPROMISE Endowment Scholarship	
Jose O. Rios		03/04/2024	AlamoPROMISE Endowment Scholarship	
Jose O. Rios		03/19/2024	AlamoPROMISE Endowment Scholarship	
Jennifer A. Riske		03/01/2024	Nighthawk Nest Program	
Michelle Risse		03/01/2024	Scobee Education Center Programs	
Ida H. Rivera		03/01/2024	Student Emergency Fund	

Donor Name	Soft Credit Recipient Name	Gift Date	Fund Description	Honor / Memorial Name
Ida H. Rivera		03/01/2024	Dr. Adena Williams Loston Presidential Scholarship	
Jennifer M. Rivera		03/01/2024	PAC LeadHERS	
Sergio M. Rivera		03/01/2024	Employee Benevolence Fund	
Teresa J. Robledo		03/01/2024	Child Care Center	
Cassandra Rocha		03/01/2024	Safe S.P.A.C.E. (Supporting People through Advocacy, Care and Equity)	
Frances L. Rocha		03/01/2024	AlamoPROMISE Endowment Scholarship	
Barbara A. Rodriguez		03/01/2024	PAC SHARE Program	
Briana Rodriguez		03/01/2024	AlamoPROMISE Endowment Scholarship	
Crystal Rodriguez		03/01/2024	PAC LeadHERS	
Estephani M. Rodriguez		03/01/2024	International Education Scholarship	
Gabriel R. Rodriguez		03/01/2024	AlamoPROMISE Endowment Scholarship	
Gabriel R. Rodriguez		03/01/2024	Student Emergency Fund	
Julian Rodriguez		03/01/2024	Jane Moser Drum Encouragement Endowment Program	
Julian Rodriguez		03/01/2024	San Antonio peaceCENTER	
Julian Rodriguez		03/01/2024	Vista Food Pantry	
Luis A. Rodriguez		03/01/2024	SPC Homebuilding Scholarship	
Luis A. Rodriguez		03/01/2024	Professional Aviation Maintenance Scholarship	
Luis A. Rodriguez		03/01/2024	VOTC Veterans Outreach & Transition Center Program	
Luis A. Rodriguez		03/01/2024	William C. Davis Endowed Scholarship	
Marco A. Rodriguez		03/01/2024	AlamoPROMISE Endowment Scholarship	
Marco A. Rodriguez		03/01/2024	Annual Fund	
Marco A. Rodriguez		03/01/2024	General Foundation Scholarship Fund	
Marco A. Rodriguez		03/01/2024	Student Emergency Fund	
Jacques Rogers		03/01/2024	AlamoPROMISE Endowment Scholarship	
Jecoa Ross		03/01/2024	G.A.L.A. (Gay & Lesbian Association) Scholarship	
Jecoa Ross		03/01/2024	SAC Honors Academy	
Jecoa Ross		03/01/2024	SAC Mexican American Studies (MAS) Program	
Jecoa Ross		03/01/2024	President's Unrestricted SAC	
Jecoa Ross		03/01/2024	SAC Student Support Fund	
Dania V. Rossi		03/01/2024	Nighthawk Nest Program	
Jennifer Rower		03/15/2024	Masters Leadership Program (MLP) Scholarship	
RVK Architects, Inc.		03/08/2024	PAC Fest	
Shannon Sahabi		03/01/2024	General NVC Scholarship	
Mecca M. Salahuddin		03/01/2024	Student Emergency Fund	
Mecca M. Salahuddin		03/01/2024	Artemisia Bowden Memorial Endowed Scholarship	
Fernando Salas		03/01/2024	Chancellor's Circle of Excellence Fund	
Fernando Salas		03/01/2024	PAC LeadHERS	
Guadalupe P. Salas		03/01/2024	President's Unrestricted SAC	
Roxanne Salazar		03/01/2024	PAC LeadHERS	
Felix Salinas		03/01/2024	NVC Alumni Association Scholarship	
Felix Salinas		03/01/2024	NVC Faculty / Staff Scholarship	
Felix Salinas		03/01/2024	NVC Fans General Support	
Felix Salinas		03/01/2024	NVC Fine & Performing Arts Endowed Scholarship	
Felix Salinas		03/01/2024	NVC Compassion (President's Unrestricted Fund)	
Valentin Salinas		03/01/2024	AlamoPROMISE Endowment Scholarship	
Valentin Salinas		03/01/2024	Employee Benevolence Fund	
Roosevelt Salters		03/01/2024	Golf Tournament SPC	
San Antonio Livestock Exposition, Inc.		03/19/2024	San Antonio Livestock Exposition, Inc. (SALE) Scholarship PAC Only	
San Antonio Spurs		03/28/2024	Interim Program	
Cheri L. Sanchez		03/01/2024	Child Care Center	
Cheri L. Sanchez		03/01/2024	President's Unrestricted SAC	
Edward A. Sanchez		03/01/2024	Employee Benevolence Fund	
Joe J. Sanchez		03/21/2024	Mosaico AlamoPROMISE Event	
Patricia A. Sanchez		03/01/2024	President's Unrestricted SAC	
Patricia A. Sanchez Gorentz		03/01/2024	Annual Fund	
Lance E. Sandberg		03/01/2024	Taylor & Ronda Chandler Math & Sciences Endowed Scholarship	
Jason E. Santos		03/01/2024	General Foundation Scholarship Fund	
Savannah R. Santos		03/01/2024	Horticulture Scholarship	
Savannah R. Santos		03/01/2024	ECO-Centro Program	
Savannah R. Santos		03/01/2024	SAC Wilderness Program	
Adam G. Saucedo		03/01/2024	General NLC Scholarship	
Anonymous		03/01/2024	General NLC Scholarship	
Anonymous		03/01/2024	Nighthawk Nest Program	
Anonymous		03/01/2024	NLC President Cares Unrestricted Fund	
SAZA Commission, Inc.		03/08/2024	Golf Tournament SPC	
Jennifer L. Scheidt		03/01/2024	PAC LeadHERS	
Jennifer L. Scheidt		03/01/2024	President's Unrestricted PAC	
Jennifer L. Scheidt		03/01/2024	Samantha Tapia Formative Endowed Scholarship	
Kori L. Schneider		03/01/2024	AlamoPROMISE Endowment Scholarship	
Kori L. Schneider		03/01/2024	Beverly Evans Memorial NVC Student Live Scholarship	
Kori L. Schneider		03/01/2024	NVC Faculty / Staff Scholarship	
Kori L. Schneider		03/01/2024	General NVC Scholarship	
Kori L. Schneider		03/01/2024	San Antonio peaceCENTER	
Kori L. Schneider		03/01/2024	Vista Food Pantry	
Brian B. Schonefeld		03/01/2024	Annual Fund	
Brian B. Schonefeld		03/01/2024	Employee Benevolence Fund	
Brian B. Schonefeld		03/01/2024	General Foundation Scholarship Fund	
Brian B. Schonefeld		03/01/2024	Student Emergency Fund	
Peggy D. Scott		03/01/2024	Employee Benevolence Fund	
Sanjuanita C. Scott		03/01/2024	San Antonio peaceCENTER	
Alma Segovia		03/01/2024	PAC Athletics Program	
Alma Segovia		03/01/2024	James B. Riley Formative Endowed Scholarship	
Alma Segovia		03/01/2024	President's Unrestricted PAC	
Alma Segovia		03/01/2024	Samantha Tapia Formative Endowed Scholarship	
Alma Segovia		03/01/2024	PAC SHARE Program	
Mary M. Segovia		03/01/2024	President's Unrestricted SAC	
Cassandra V. Segura		03/01/2024	AlamoPROMISE Endowment Scholarship	
Cassandra V. Segura		03/01/2024	Annual Fund	
Cassandra V. Segura		03/01/2024	Employee Benevolence Fund	
Cassandra V. Segura		03/01/2024	General Foundation Scholarship Fund	
Cassandra V. Segura		03/01/2024	Student Emergency Fund	
Jason M. Seighman		03/01/2024	Nighthawk Nest Program	
Webb Setters		03/21/2024	Mosaico AlamoPROMISE Event	
Jennifer Senia		03/01/2024	AlamoPROMISE Endowment Scholarship	
Jennifer Senia		03/01/2024	Student Emergency Fund	
Daniela Serna		03/23/2024	Mosaico AlamoPROMISE Event	
Elena Serna-Wallender		03/22/2024	Student Emergency Fund	

Donor Name	Soft Credit Recipient Name	Gift Date	Fund Description	Honor / Memorial Name
Luis D. Sevilla		03/01/2024	DREAMers Scholarship	
Anonymous		03/21/2024	President's Unrestricted SPC	
Erin L. Sherman		03/01/2024	General NVC Scholarship	
Erin L. Sherman		03/01/2024	James B. Riley Formative Endowed Scholarship	
Loretta E. Sibley		03/01/2024	Artemisia Bowden Memorial Endowed Scholarship	
Loretta E. Sibley		03/01/2024	Dr. Adena Williams Loston Presidential Scholarship	
Loretta E. Sibley		03/01/2024	Generat SPC Scholarship	
Nicolas D. Silva		03/01/2024	AlamoPROMISE Endowment Scholarship	
Zhennia R. Silverman		03/14/2024	Marie Rocamontes Henriquez International Endowed Program	Marie Rocamontes Henriquez
Zhennia R. Silverman		03/29/2024	Marie Rocamontes Henriquez International Endowed Program	Marie Rocamontes Henriquez
Zhennia R. Silverman		03/29/2024	Marie Rocamontes Henriquez International Endowed Program	Marie Rocamontes Henriquez
Adia Simpson		03/01/2024	Bits 'n Bytes PAC	
Barton T. Simpson		03/01/2024	Simpson Family FORMATIVE Endowed Nursing Scholarship	
Theresa A. Sinclair		03/01/2024	Norma L. Ziegler Memorial Endowed Scholarship	
Melissa J. Slocumb		03/01/2024	Rea & Barbara Hinrichs Endowed Scholarship	
Elvira Smolik		03/01/2024	Annual Fund	
Veronica Sotis		03/01/2024	PAC LeadHERS	
Tyshee E. Sonnier		03/01/2024	SAC Honors Academy	
Tyshee E. Sonnier		03/01/2024	Ron Lucke Speech & Drama Scholarship	
Chris B. Sosa		03/01/2024	Annual Fund	
Southwest I.S.D.		03/19/2024	PAC Fest	
Southwest I.S.D.		03/19/2024	PAC Fest	
Eugene A. Sprague		03/21/2024	Mosaico AlamoPROMISE Event	
Robert Stalkrecht		03/01/2024	Annual Fund	
Sue E. Stankus		03/01/2024	General NLC Scholarship	
Sue E. Stankus		03/01/2024	Nighthawk Nest Program	
Stantec Architecture		03/29/2024	Golf Tournament SPC	
Stewart Organization		03/21/2024	Mosaico AlamoPROMISE Event	
Amber D. Stillwagon		03/01/2024	General Foundation Scholarship Fund	
Amber D. Stillwagon		03/01/2024	Student Emergency Fund	
Terrance Stokes		03/01/2024	Dr. Adena Williams Loston Presidential Scholarship	
Terrance Stokes		03/01/2024	Generat SPC Scholarship	
Julia A. Stotts		03/01/2024	AlamoPROMISE Endowment Scholarship	
Julia A. Stotts		03/01/2024	Continuing Education Training Gifts Fund	
Julia A. Stotts		03/01/2024	Emergency Grant Fund Program	
Julia A. Stotts		03/01/2024	Employee Benevolence Fund	
Julia A. Stotts		03/01/2024	GED Empowerment to College Endowed Scholarship	
Julia A. Stotts		03/01/2024	General Foundation Scholarship Fund	
Julia A. Stotts		03/01/2024	Student Emergency Fund	
Patricia Stout		03/30/2024	Interim Program	
Anonymous		03/27/2024	General NVC Scholarship	Patrick White
Cindy M. Sullivan		03/01/2024	Vista Food Pantry	
Chris Talley		03/01/2024	Masters Leadership Program (MLP) Scholarship	
Rachel E. Tapia		03/29/2024	President's Unrestricted SPC	
Richard G. Terrell		03/01/2024	Annual Fund	
Texas A&M University-San Antonio		03/13/2024	Mosaico AlamoPROMISE Event	
Texas A&M University-San Antonio		03/13/2024	Mosaico AlamoPROMISE Event	
Michelle M. Theiss		03/01/2024	Rea & Barbara Hinrichs Endowed Scholarship	
Michelle M. Theiss		03/01/2024	SAC Student Support Fund	
Sloan Thomas		03/05/2024	Mosaico AlamoPROMISE Event	
Isaac L. Thornsburg		03/01/2024	NLC President Cares Unrestricted Fund	
Peter E. Thorsett		03/01/2024	Chancellor's Circle of Excellence Fund	
Jacquelyn C. Tocchi-Wallpe		03/01/2024	Vista Food Pantry	
Tammy L. Toney		03/01/2024	International Education Scholarship	
David Torres		03/01/2024	Dr. Adena Williams Loston Presidential Scholarship	
Dianna S. Torres Lee		03/01/2024	Nighthawk Nest Program	
Alexandra Tray		03/01/2024	SAC Student Support Fund	
Hector Trevino		03/01/2024	Vista Food Pantry	
Jamie E. Trevino		03/01/2024	AlamoPROMISE Endowment Scholarship	
Jamie E. Trevino		03/01/2024	Employee Benevolence Fund	
Jesse R. Trevino		03/01/2024	AlamoPROMISE Endowment Scholarship	
Joe Trinidad		03/01/2024	General SPC Scholarship	
John Trinidad		03/01/2024	SAC Student Support Fund	
Ryan A. Tyson		03/01/2024	AlamoPROMISE Endowment Scholarship	
United Way of San Antonio & Bexar County		03/11/2024	United Way Student Helpline	
University Health System		03/08/2024	PAC Fest	
University of Texas - Rio Grande Valley		03/06/2024	PAC Fest	
The University of Texas at San Antonio		03/18/2024	PAC Fest	
UPS Store #6315		03/29/2024	Golf Tournament SPC	
Xavier D. Urrutia		03/01/2024	AlamoPROMISE Endowment Scholarship	
Xavier D. Urrutia		03/01/2024	Economic & Workforce Development Program Fund	
Catherine B. Valdiviez		03/01/2024	PAC LeadHERS	
Catherine B. Valdiviez		03/01/2024	PAC Special Events	
Valero Energy Foundation		03/04/2024	Golf Tournament SPC	
Malorie E. Vallejo		03/01/2024	James B. Riley Formative Endowed Scholarship	
Malorie E. Vallejo		03/01/2024	PAC LeadHERS	
Malorie E. Vallejo		03/01/2024	President's Unrestricted PAC	
Malorie E. Vallejo		03/01/2024	Samantha Tapia Formative Endowed Scholarship	
Malorie E. Vallejo		03/01/2024	PAC SHARE Program	
Doug VanderPloeg		03/21/2024	Mosaico AlamoPROMISE Event	
Vanguard Charitable	Robert Hoek	03/28/2024	NVC Fine and Performing Arts Student Support Program Fund	
Cates Vanham		03/21/2024	Mosaico AlamoPROMISE Event	
Alejandro Vargas		03/15/2024	AlamoPROMISE Endowment Scholarship	
Clarissa Vargas		03/01/2024	SAC Student Support Fund	
Albert Vasquez		03/01/2024	SAC Student Support Fund	
Dominic R. Vasquez		03/01/2024	PAC LeadHERS	
Dominic R. Vasquez		03/01/2024	PAC SHARE Program	
Stephanie V. Vasquez		03/01/2024	AlamoPROMISE Endowment Scholarship	
Cathy R. Vega		03/01/2024	Clarence Norris Endowed Scholarship	
Cathy R. Vega		03/01/2024	Dr. Adena Williams Loston Presidential Scholarship	
Patricia D. Vela		03/01/2024	AlamoPROMISE Endowment Scholarship	
Melissa A. Velasquez		03/01/2024	Angela de Hoyos Scholarship - Mexican American Studies Scholarship	
Carmen M. Velasquez-Avila		03/01/2024	PAC LeadHERS	
Carmen M. Velasquez-Avila		03/01/2024	PAC SHARE Program	
Franchesca Velten		03/01/2024	Annual Fund	
Franchesca Velten		03/01/2024	Employee Benevolence Fund	
James R. Velten		03/01/2024	KSYM Program	

Donor Name	Soft Credit Recipient Name	Gift Date	Fund Description	Honor / Memorial Name
Usha M. Venkat		03/01/2024	David E Mrizek Endowed Scholarship Fund	
Joseph J. Vidaurri		03/01/2024	General Foundation Scholarship Fund	
Lisa M. Villaneuva		03/01/2024	Student Emergency Fund	
Anna Villarreal		03/01/2024	DREAMers Scholarship	
Brandilyn S. Villarreal		03/01/2024	Tourism, Hospitality, Culinary Arts (THCA) Scholarship	
Lori Villarreal		03/01/2024	Student Emergency Fund	
Lori Villarreal		03/01/2024	Vista Food Pantry	
Mary G. Villarreal		03/01/2024	AlamoPROMISE Endowment Scholarship	
Anonymous		03/21/2024	Mosaico AlamoPROMISE Event	
Anonymous		03/21/2024	Mosaico AlamoPROMISE Event	
Anonymous		03/21/2024	Mosaico AlamoPROMISE Event	
Marco A. Visa		03/01/2024	Artemisia Bowden Memorial Endowed Scholarship	
Marco A. Visa		03/01/2024	Dr. Adena Williams Loston Presidential Scholarship	
Patrick F. Vrba		03/01/2024	AlamoPROMISE Endowment Scholarship	
Patrick F. Vrba		03/01/2024	Annual Fund	
Ivana Vukmirovic		03/01/2024	PAC SHARE Program	
Dehliia A. Wallis		03/01/2024	SAC Honors Academy	
Dehliia A. Wallis		03/01/2024	SAC Student Support Fund	
Donna R. Wallis		03/01/2024	President's Unrestricted PAC	
Monica Walseman		03/01/2024	AlamoPROMISE Endowment Scholarship	
Gregory A. Ward		03/01/2024	Dennis Gittinger Endowed Scholarship for Mathematics	
Michael D. Ward		03/01/2024	San Antonio peaceCENTER	
Michael D. Ward		03/01/2024	Vista Food Pantry	
Yolanda Y. Ward		03/01/2024	Student Emergency Fund	
Anthony Warren		03/20/2024	Masters Leadership Program (MLP) Scholarship	
Kimberly Wells		03/01/2024	Empowerment Center Program	
Kimberly Wells		03/01/2024	Generat SAC Scholarship	
Kimberly Wells		03/01/2024	SAC Student Support Fund	
Lorri A. Wells		03/01/2024	Dr. Veronica R. Garcia President's Leadership Scholarship	
Lorri A. Wells		03/01/2024	Betty Cunningham FORMATIVE Endowed Scholarship 9/7/2025	
Lorri A. Wells		03/01/2024	President's Unrestricted PAC	
Lorri A. Wells		03/01/2024	President's Unrestricted SAC	
Lorri A. Wells		03/01/2024	Dr. Adena Williams Loston Presidential Scholarship	
Wesley B. Wells		03/01/2024	Dr. Adena Williams Loston Presidential Scholarship	
Wesley B. Wells		03/01/2024	SPC President's Student Aid Fund	
Wesley B. Wells		03/01/2024	Student Engagement Scholarship SPC	
Teri Wenglein		03/21/2024	Mosaico AlamoPROMISE Event	
Shayne A. West		03/01/2024	AlamoPROMISE Endowment Scholarship	
WestEast Design Group, LLC		03/01/2024	Golf Tournament SPC	
Christopher Whan		03/27/2024	AlamoPROMISE Endowment Scholarship	
Whatabrands LLC		03/13/2024	PAC Fest	
Shawn C. White		03/01/2024	AlamoPROMISE Endowment Scholarship	
Torence B. White		03/01/2024	Tourism, Hospitality, Culinary Arts (THCA) Scholarship	
Valarie D. White		03/01/2024	AlamoPROMISE Endowment Scholarship	
Harold G. Whitis		03/01/2024	Annual Fund	
Karin A. Wilking		03/01/2024	Vista Food Pantry	
Daniel F. Williams		03/01/2024	General SPC Scholarship	
James C. Williams		03/01/2024	Dr. Adena Williams Loston Presidential Scholarship	
Diane I. Wilson		03/01/2024	PAC Dental Hygiene Ed Program and Community Clinic	
Michelle R. Wilson		03/01/2024	AlamoPROMISE Endowment Scholarship	
Michelle R. Wilson		03/01/2024	Annual Fund	
Michelle R. Wilson		03/01/2024	Employee Benevolence Fund	
Kimberley Wolf		03/01/2024	General Foundation Scholarship Fund	
Darren L. Wood		03/01/2024	AlamoPROMISE Endowment Scholarship	
Worcester Polytechnic Institute		03/06/2024	San Antonio peaceCENTER	
Nina B. Wright		03/01/2024	Employee Benevolence Fund	
Nina B. Wright		03/01/2024	Employee Benevolence Fund	
Kristi R. Wyatt		03/01/2024	AlamoPROMISE Endowment Scholarship	
Kristi R. Wyatt		03/21/2024	Mosaico AlamoPROMISE Event	
Michael L. Ximenez		03/01/2024	James B. Riley Formative Endowed Scholarship	
Michael L. Ximenez		03/01/2024	PAC LeadHERS	
Michael L. Ximenez		03/01/2024	President's Unrestricted PAC	
Michael L. Ximenez		03/01/2024	Samantha Tapia Formative Endowed Scholarship	
Michael L. Ximenez		03/01/2024	PAC SHARE Program	
Robert J. Yeater		03/01/2024	NVC Alumni Association Scholarship	
Robert J. Yeater		03/01/2024	General NVC Scholarship	
Irene W. Young		03/01/2024	Artemisia Bowden Memorial Endowed Scholarship	
Irene W. Young		03/01/2024	Safe S.P.A.C.E. (Supporting People through Advocacy, Care and Equity)	
Robert O. Yowell		03/01/2024	Faculty Endowment Scholarship	
Jennifer R. Zamarripa		03/01/2024	AlamoPROMISE Endowment Scholarship	
Blanca R. Zapata		03/25/2024	President's Unrestricted SPC	
Grace A. Zapata		03/01/2024	Mary A. Kunz and Jack G. Kline Endowed Scholarship	
Grace A. Zapata		03/01/2024	Safe S.P.A.C.E. (Supporting People through Advocacy, Care and Equity)	
Dolores Zapata-Caballero		03/01/2024	AlamoPROMISE Endowment Scholarship	
Maricruz Zarate		03/01/2024	Employee Benevolence Fund	
Cuihua Zhang		03/01/2024	Faculty Endowment Scholarship	
Bekalyn Zimmerman		03/25/2024	William C. Davis Endowed Scholarship	

TOTAL \$ 999,386.57



ALAMO
COLLEGES
DISTRICT

**OFFICE OF INSTITUTIONAL ADVANCEMENT
& ALAMO COLLEGES FOUNDATION
March 2024
SUMMARY FINANCIAL REPORT
May 21, 2024 BOARD REPORT**

	Net Assets without Donor Restrictions (Unrestr)		Net Assets With Donor Restrictions				Total			
	Month	YTD	Non-Endowed (Temp Restr) Month	YTD	T Restr Tied to Endowed Month	YTD	Endowed Funds (Perm Restr) Month	YTD	Month	YTD
Revenues:										
Donations	3,713.01	24,935.20	348,504.27	1,153,046.21	-	-	647,169.29	746,159.93	999,386.57	1,924,141.34
Funds from ACCD										
Other Income					66.01	66.01			66.01	66.01
Interest and Dividends*	631.72	1,850.89	76,694.51	141,545.75	115,203.85	217,487.71	-	-	192,530.08	360,884.35
Alamo Colleges PR Contributions										
Net Assets Released from Restricted										
Subtotal Revenues	4,344.73	26,786.09	425,198.78	1,294,591.96	115,269.86	217,553.72	647,169.29	746,159.93	1,191,982.66	2,285,091.70
Gifts - Non Cash										
Total Revenues & Gifts Non Cash	4,344.73	26,786.09	425,198.78	1,294,591.96	115,269.86	217,553.72	647,169.29	746,159.93	1,191,982.66	2,285,091.70
Expenses	2,123.60	7,404.73	220,382.01	815,285.58	35,715.00	279,125.26	-	-	258,220.61	1,101,815.57
Transfers										
Realized/Unrealized gains (losses)	-	-	(3,095.34)	(2,412.14)	(4,693.33)	(4,693.33)	7,788.67	7,105.47	-	-
			750,238.89	1,518,941.83	986,458.74	1,964,532.32			1,736,697.63	3,483,474.15
Net Surplus/(Deficit)	2,221.13	19,381.36	951,960.32	1,995,836.07	1,061,320.27	1,898,267.45	654,957.96	753,265.40	2,670,459.68	4,666,750.28
Net Assets beginning of period	410,858.40	393,698.17	43,222,875.42	42,178,999.67	10,979,118.72	10,142,171.54	24,748,990.53	24,650,683.09	79,361,843.07	77,365,552.47
Net Assets at end of period	413,079.53	413,079.53	44,174,835.74	44,174,835.74	12,040,438.99	12,040,438.99	25,403,948.49	25,403,948.49	82,032,302.75	82,032,302.75

Notes
 Net Assets without Donor Restriction (Unrestricted) = not connected with an endowment. Unrealized Gains=Mkt increases over the initial cost of investment. Realized when security is sold.
 Net Assets with Donor Restrictions, Non-Endowed (Temporarily Restricted) = Available for Spending. Monthly financial statement prepared by Alamo Colleges District Finance Office.
 Net Assets with Donor Restrictions Endowed (Permanently Restricted) = Can never be spent.

FUND BALANCE TREND	12/31/2023	12/31/2022	12/31/2021	12/31/2020	12/31/2019	12/31/2018	12/31/2017	12/31/2016	12/31/2015	12/31/2014
Net Assets without Donor Restr (Unrestricted)	303,188.42	177,749.79	138,419.44	149,977.07	98,103.66	67,941.69	16,718.26	529,890.70	234,029.28	
Net Assets w/Donor Restrictions										
Non-Endowed (Temp Restr)	42,730,461.95	41,368,182.61	27,742,633.67	4,975,295.10	4,093,550.09	3,620,377.85	6,397,320.16	5,586,007.58	6,632,301.44	
Net Assets w/Donor Restrictions										
Non-Endwd Tied to Endowed (Temp Restr)	11,514,639.26	8,356,695.21	6,228,998.38	3,036,018.63	5,030,887.21	3,076,441.20				
Endowed Funds (Permanently Restricted)	22,199,871.74	21,214,716.16	20,281,703.94	18,926,008.86	18,296,735.75	17,352,580.77	16,459,361.30	13,805,433.36	13,431,659.93	
Realized/Unrealized gains (losses)	(12,397,062.63)	4,266,247.96	2,945,642.61	3,741,890.31	(1,633,069.72)	2,510,880.49	807,898.49	(703,480.22)	233,387.53	
Total Funds	\$ -	\$ 64,351,098.74	\$ 75,383,591.73	\$ 57,337,398.04	\$ 30,829,189.97	\$ 25,886,206.99	\$ 26,628,222.00	\$ 23,681,298.21	\$ 19,217,851.42	\$ 20,531,378.18
Net Profit/(Loss)	\$ (11,032,492.99)	\$ 18,046,193.69	\$ 26,508,208.07	\$ 4,942,982.98	\$ (742,015.01)	\$ 2,946,923.79	\$ 4,463,446.79	\$ (1,313,526.76)	\$ 2,492,072.44	

FUND BALANCE TREND	12/31/2013	12/31/2012	12/31/2011	12/31/2010	12/31/2009
Net Assets without Donor Restr (Unrestricted)	119,758.06	91,714.28	91,542.46	103,902.09	104,578.84
Net Assets w/Donor Restrictions					
Non-Endowed (Temp Restr)	3,875,721.09	3,382,609.17	2,744,566.51	2,530,063.08	1,994,094.48
Net Assets w/Donor Restrictions					
Non-Endwd Tied to Endowed (Temp Restr)	12,267,711.48	11,574,473.53	10,405,600.60	9,695,681.21	8,766,099.06
Endowed Funds (Permanently Restricted)	1,776,115.11	366,084.74	(474,263.50)	(47,331.10)	(229,024.18)
Realized/Unrealized gains (losses)					
Total Funds	\$ 18,039,305.74	\$ 15,414,881.72	\$ 12,767,446.07	\$ 12,282,315.28	\$ 10,635,748.20
Net Profit/(Loss)	\$ 5,756,990.46	\$ 2,647,435.65	\$ 2,131,697.87	\$ 1,646,567.08	\$ 3,966,864.20



MEMORANDUM

TO: Dr. Mike Flores, Chancellor
Alamo Colleges District

THRU: Dr. Thomas Cleary, Interim Vice Chancellor for Finance and
Administration
Alamo Colleges District

FROM: Derek Fuller, Chief of Public Safety
Alamo Colleges District Police Department

DATE: May 06, 2024

SUBJECT: **MONTHLY ACTIVITY REPORT**

Please find the attached Alamo Colleges District Police Department's Monthly CLERY Act activity report through April 2024 and yearly totals summary page. Please note that the report reflects new CLERY reporting activity categories enacted in 2008 and required beginning in 2009 when a bias motivation is present, including the Theft / Larceny category which was not part of the previous CLERY reporting requirement however was previously included for informational purposes. None were motivated by bias or hate. The CLERY Act was amended in 2011, effective for reporting year 2011, to include reports received for Simple Assault that are motivated by bias or hate. Simple Assaults are included in this report for information purposes however none were motivated by bias or hate. The CLERY Act was amended in 2014 as per VAWA and Campus SaVE Acts, effective 2015 to include reports of Domestic Violence, Dating Violence and Stalking.

Burglary of motor vehicle is considered a theft from a vehicle under Uniform Crime Reporting definitions and therefore is included in the Theft category for CLERY purposes. For CLERY reporting purposes the Theft / Larceny category includes all thefts and burglary of motor vehicle reports made to the Alamo Colleges District Police Department and is reported as one total when reported to the Department of Education and published by the Department in its annual report. They have, however, been separated for this report.

Theft totals listed on this report include all thefts of district property and personal property belonging to students, faculty and staff reported to the Alamo Colleges District Police Department.



"The vision of the Alamo Colleges Police Department is To Be The Best in The Nation" while fulfilling its mission of providing a safe environment through a high level of proficiency in which all members of the District community may work, teach, study and learn. This department, in the daily performance of its function, stresses: Service, the protection of life, property and investment, the security of the campuses, and the pursuit of excellence in campus law enforcement and safety.

ALAMO COLLEGES POLICE DEPARTMENT

MONTHLY 2024 CLERY ACT ACTIVITY REPORT

CLERY ACT CATEGORY	Jan	Feb	Mar	Apr	May	Jun	Jul	Aug	Sep	Oct	Nov	Dec	Total
<i>Murder / Non - Negligent Manslaughter</i>	0	0	0	0	0	0	0	0	0	0	0	0	0
<i>Negligent Manslaughter</i>	0	0	0	0	0	0	0	0	0	0	0	0	0
<i>Sex Offenses / Forcible</i>	0	0	0	0	0	0	0	0	0	0	0	0	0
<i>Sex Offenses / Non-Forcible</i>	0	0	0	0	0	0	0	0	0	0	0	0	0
<i>Robbery</i>	1	0	0	0	0	0	0	0	0	0	0	0	1
<i>Aggravated Assault</i>	0	0	0	0	0	0	0	0	0	0	0	0	0
<i>Simple Assault</i>	2	4	1	4	0	0	0	0	0	0	0	0	11
<i>Intimidation</i>	1	0	1	4	0	0	0	0	0	0	0	0	6
<i>Vandalism</i>	2	7	8	6	0	0	0	0	0	0	0	0	23
<i>Burglary</i>	0	1	2	0	0	0	0	0	0	0	0	0	3
<i>Theft - Larceny</i>	6	7	3	4	0	0	0	0	0	0	0	0	20
<i>Burglary of Vehicle</i>	1	2	3	1	0	0	0	0	0	0	0	0	7
<i>Motor Vehicle Theft</i>	0	2	2	0	0	0	0	0	0	0	0	0	4
<i>Arson</i>	0	0	0	0	0	0	0	0	0	0	0	0	0
<i>Arrest Illegal Weapons Possession</i>	0	0	0	0	0	0	0	0	0	0	0	0	0
<i>Discipline Illegal Weapons Possession</i>	0	0	0	0	0	0	0	0	0	0	0	0	0
<i>Arrest Drug Law Violations</i>	4	8	1	5	0	0	0	0	0	0	0	0	18
<i>Discipline Drug Law Violations</i>	0	0	0	0	0	0	0	0	0	0	0	0	0
<i>Arrest Liquor Law Violations</i>	0	0	0	0	0	0	0	0	0	0	0	0	0
<i>Discipline Liquor Law Violations</i>	0	0	0	0	0	0	0	0	0	0	0	0	0
<i>Hate Crimes Race / Gender</i>	0	0	0	0	0	0	0	0	0	0	0	0	0
<i>Hate Crimes Religion / Sexual Orientation</i>	0	0	0	0	0	0	0	0	0	0	0	0	0
<i>Hate Crimes Ethnicity / Disability</i>	0	0	0	0	0	0	0	0	0	0	0	0	0
<i>Domestic Violence</i>	0	0	0	0	0	0	0	0	0	0	0	0	0
<i>Dating Violence</i>	0	0	0	0	0	0	0	0	0	0	0	0	0
<i>Stalking</i>	0	0	0	0	0	0	0	0	0	0	0	0	0

The CLERY Act was amended in 2008, effective for reporting year 2009, to include reports received for Burglary, Theft including Burglary of Vehicle that are motivated by bias or hate. The CLERY Act was amended in 2011, effective for reporting year 2011, to include reports received for Simple Assault that are motivated by bias or hate. The CLERY Act was amended in 2014 as per VAWA and Campus SaVE Acts, effective 2015 to include reports of Domestic Violence, Dating Violence and Stalking.

None of the activity reflected on this report were bias motivated but are provided for informational purposes.

Significant Activity in April:

*The below reports include arrests by being booked into 201 N. Comal (The Justice Intake Assessment Annex), by being issued a citation (other than traffic), or by being detained and released with the possible pending charges being filed with the Bexar County District Attorney's Office.

1) SAC (073744 – Possession / Deliver Drug Paraphernalia) On 04/01/2024, while patrolling the campus, officers observed what appeared to be tarps, set up like a makeshift campsite in Lot 32. The officer spoke with a male (non-student) who was inside the tent and the male said he was taking a break and resting. The officer informed the male it was illegal to set up a campsite on the campus. The officer had dispatch check the male for wants/warrants, and he did not have any. While the officer was speaking with the male, he saw a bulge in his right pocket and a lighter sticking out of his pocket. The officer asked the male if they could search for his person, which he agreed. The officer also asked if they could check his backpack, to which he consented. The officer searched the backpack and found multiple broken glass pipes with burnt residue. The officer confiscated the pipes for safekeeping and informed the male due to his cooperation and honesty, they would not be pursuing charges and was released at the scene after having the male remove his camp.

2) PAC (073747 – Emergency Detention) On 04/02/2024, an officer was dispatched to Medina Hall to meet with an individual who contacted 911 and expressed suicidal thoughts. Upon arrival the officer met with an adult male (non-student) who expressed that he had been depressed for several days and this morning he had thoughts of hurting himself. The male told the officer he wanted to kill himself because he was tired of being away from his family and friends. The male asked the officers if they could help him get to a hospital. The male was transported Methodist Hospital Specialty and Transplant Emergency Room where he was admitted for further medical evaluation.

3) NVC (073775 – Terroristic Threat) On 04/05/2024 the campus Sgt. received information from the Director of Marketing & Strategic Communication / Public Relations regarding two screenshots of concerning comments posted on the Northwest Vista College Facebook page. The concerning post made under the Solar Eclipse event post which stated, "BTW YOU SHOULD LOOK AT THE HORZION MORE WHERE WE ARE DROPPING ANTHRAX SPARKLE NUKES OF EVERY TYPE OF ANTHRAX BECAUSE YYYYAYY ANTHRAX." Alamo College investigators began to look into the individual who made the comment and collaborated with the San Antonio Fusion Center, and the FBI. Investigators were able to determine who the male individual was (non-student/former NVC student). ACPD investigators and SAPD mental health unit went to his residence to speak to him regarding the comment he made. Upon further investigation, and speaking with his parents, it was determined the male's mental capacity was severely diminished and the male was taken to The San Antonio Behavioral Health Hospital for further evaluation and care. Charges for terroristic threat will be filed.

4) SAC (073778 – Possession of Marihuana & Possession / Deliver Drug Paraphernalia) On 04/06/2024, the officer noticed a vehicle parked on the first level of the SAC parking garage with the passenger door open. The officer approached the vehicle and saw two female individuals (non-students) sleeping inside with the car engine shut off. The officer woke the females and asked them what they were doing. The female in the driver seat, told the officer they were at the clubs and her passenger was intoxicated. The officer had dispatch check both females for any wants / warrants and both came back clear. The officer asked the driver if there was marijuana in the car due to the officer smelling marijuana emitting from the vehicle and she said, "no." When the officer asked the passenger if there was marihuana in the car, she said, "yes," and she opened the middle

compartment and showed the officer a Ziploc baggie with marijuana residue. The officer also found an open bottle of vodka on the passenger side door, which was confiscated from the vehicle. The passenger was issued a City of San Antonio misdemeanor citation for possession of drug paraphernalia. Both females were released without further incident.

5) PAC (073794 – Emergency Detention) On 04/09/2024, an officer was informed by dispatch of a possible homeless female walking around campus wearing what appeared to be a hospital gown. Officer were able to locate the described female who was not wearing a hospital gown but wearing a light blue dress with a body style towel wrapped around her waist. The female is a known student to campus police who has multiple reports for her mental concerns. When the officer approached the female, she immediately shut down and began to weep and would not engage verbally with the officer. The officer began to observe the student's behavior was erratic, pacing back and forth then suddenly she would stop talking again and begin talking about angels at a church and how she needed to go to that church. The female was transported to University Hospital for further evaluation and care.

6) SAC (073803 – Harassment) On 04/08/2024 officers were dispatched to the Oppenheimer Academic Center for a male student who wanted to report threats being made to him. Upon arrival, the officer spoke with the male student who said he received text messages from a number he did not recognize threatening him to pay money he allegedly owed to this unknown person. The student stated he has not responded and does not know who the person may be. Investigation continues.

7) SAC (073810 – Public Intoxication Alternative to Arrest) On 04/10/2024, while patrolling the area of Howard Loop near the Veterans Victory Center, the officers observed a female wearing black shorts and a black hooded sweater walking on the sidewalk. The female appeared to be hiding something in her jacket and when she saw the marked patrol unit, she turned in the opposite direction. The officer stopped the female (non-student) who stated she was dropped off near Walgreens and caught the bus to where she currently was. The officer noticed she had slurred speech and was speaking very lethargic. The officer asked the female when the last time was, she used narcotics and she stated heroin was her drug of choice, but she hadn't used in two days and was given Fentanyl on 04/09. Dispatch informed the officer the female was a registered sex offender. Upon further investigation, the female was transported to the San Antonio Sobering Unit where she was released to medical staff.

8) ACCESS (073822 – Emergency Detention) On 04/10/2024 while patrolling ACCESS, the officer heard someone yelling loudly, and then observed a male with a skateboard walk toward an emergency call box and hit it with the skateboard twice causing the activation to dispatch. The officer attempted to stop the male however he disregarded her verbal commands. The male then picked up a large rock in a threatening manner as to throw it toward the officer. The officer drew her taser and pointed it at the male (non-student). The male dropped the rock and began to walk away from the officer. The male then turned back around and advanced toward the officer with his fist clinched in a threatening manner and then sat down on the ground / curb on his own. Upon further investigation, it was determined the male was a danger to himself or others and was transported to Methodist Metropolitan Hospital for further evaluation.

9) SAC (073828 – Possession of Controlled Substance) On 04/11/2024 an officer was dispatched to the Oppenheimer second-floor restroom for an individual inside the handicap stall and appeared to have set up camp. When the officer arrived, the officer observed bags were lying on the ground, and the individual was sitting or lying on the floor with their shoes off. The officer had the person come out from the restroom stall and recognized the homeless male individual from multiple encounters of being around campus. The male told the officer he did not know the restroom was a women's restroom. The officer conducted a pat down of male and noticed fresh injection

marks (tracks) on his hands and arms and had blood coming from a fresh injection mark on his right forearm. Upon further investigation the male was found to be in possession of a used syringe and a small clear container with a crystal-like substance inside. The male was transported to the Bexar County Adult Detention Center where he was booked for possession of a controlled substance.

10) ACCESS (073829 – Fraudulent Use or Possession of Credit or Debit Card) On 04/08/2024 an officer was dispatched to the police office for a report of credit card theft. A male individual reported he received a text message regarding a charge on his credit card from the Alamo Colleges for Sabrina for class. Upon further investigation it was discovered the female who used the card is a student who has had a hold on her account since 2017. Investigation continues.

11) Off Campus (073851 – Traffic) On 04/14/2024, while the officer was driving back to PAC, he noticed a white Nissan in the right lane failing to stay inside of their lane. The Nissan also almost caused a collision. The officer initiated a traffic stop on the vehicle and contacted the male driver who also admitted to driving without a valid driver's license. There were two juvenile passengers in the vehicle at the time who were picked up by their parents. The vehicle was towed, and the male driver was issued a citation for driving with no driver license and released at the scene.

12) Off Campus (073856 – Possession of Controlled Substance / Failure to Identify / Felony Warrant) On 04/15/2024 while patrolling the campus officers saw an individual behind a business that was closed. The officers stopped and spoke to the male individual (non-student). The individual was "jittery," his pupils were dilated, he was sweating profusely, and he could not keep still. The male provided the officers with a wrong name and date of birth, however, upon further questioning, the male then provided officers with his correct name and date of birth. The officer had dispatch check him for any wants or warrants and he was then found to have an active warrant out of Goida County for Aggravated Assault with a deadly weapon and repeated violation of community supervision. The male was also found to be in possession of a container with a crystal-like substance, a plastic bag with white powdery substance and another plastic bag containing a green leafy substance. The male was arrested and transported to the Bexar County Adult Detention Center where he was booked for the active warrant, possession of controlled substance and failure to identify Fugitive from justice.

13) NLC (073872 – Disturbance) On 04/16/2024 Officers were dispatched to the Comal Learning Center for a male throwing textbooks in the library. Upon arrival officers recognized the male (non-student) from previous encounters. While speaking with the male, he handed a cellular phone he said found to the officer. The cellular phone was previously reported stolen from a housekeeper back on 03/28/2024 (ACPD case #073740). The male has been in 10 ACPD police reports since March 2024. There was no damage caused to the library or any property and the male was released at the scene without further incident. Campus administration informed about the male and the incidents and may be seeking a criminal trespass to be issued to the male.

14) SAC (073898 – Assault Contact/Offensive/Provocative in Nature) On 04/18/2024 officers responded to parking lot #3 for a Family Violence report. The female (contractor/housekeeper) stated when she arrived at work, her ex-boyfriend was waiting for her outside the building she reports to. She stated, he approached her and grabbed her left arm, pushed her, and forced her down to the ground. She stated he grabbed her purse and took her cellular phone and left the area. The female told the officers she did not feel any pain when her ex-boyfriend grabbed her arm and sat her on the curb. She also stated she did not wish to pursue any charges and only contacted the police to get help to retrieve her belongings back. She was provided with a family assistance information packet and informed how to self-file if she wishes to pursue any charges later.

15) SAC (073903 – Criminal Trespass / Possession of Controlled Substance) On 04/18/2024 while patrolling, Officers stopped and known transient from previous encounters and from a Criminal Trespass notice issued to him in 12/2023. Upon searching the male (non-student) for any contraband, he was found to be in possession of two clear plastic wrapper which contained a white crystal-like substance inside. The male was arrested and transported to the Bexar County Adult Detention Center where he was booked for the criminal trespass. Charges for the possession of controlled substance will be filed at large.

16) SPC (073908 – Disturbance) On 04/19/2024 officers were dispatched to the CHP for a disturbance. Upon arrival officers spoke to a female (student) who stated a male (student) approached her and asked her why she was recording him in a loud and aggressive tone. She stated she told the male she was not recording him, however, he felt like she was due to how she was holding her phone. Officers then spoke to the male who stated confronted the female because he felt she was recording him several times because how she was holding her phone and the camera on her phone was pointing at him. He said they exchanged words and then he left. There was no physical altercation or threats. Campus administration informed about incident.

17) ACCESS (073909 – Emergency Detention) On 04/19/2024 an officer was dispatched to the boardroom for a male sleeping on a bench outside. Upon arrival the officers attempted to waken the male (non-student). While the officer attempted to get the male to leave campus, he became aggressive and threatened to hurt and kill the officers. After several attempts to have the male leave the campus, the male continued to disregard the officers' commands, and the male was then tased. The male was taken to Baptist Hospital where he was released to medical staff for further care and evaluation.

18) SPC (073915 – Criminal Trespass) On 04/21/2024 an Officer was dispatched to the Bowden building for a door propped open by an unknown bag. Officers then located another door to a maintenance room propped open by a can. The room was searched, and the officer noticed a bag with clothes, a phone charging from an outlet on the wall and trash laying around. Upon further investigation, officers found a male squatting by the bottom of the stairwell, holding a bag of bread. The male told officers all the property laying around was his and he slept inside the building the night before and locked himself out. The male was arrested and transported to the Bexar County Adult Detention Center where he was booked for Criminal Trespass.

19) SPC (073928 – Assault Bodily Injury) On 04/22/2024 officers were dispatched for two early college high school students involved in an incident. A female high school student stated a male high school student took her backpack and hid it. The male stated he took her backpack because she threw an object (mascara) at the back of his head because she was upset, he recorded her sleeping in class and posted it on social media (Instagram). Upon further investigation, the father of the male high school student signed a prosecution affidavit refusing to prosecute. Campus administration and high school administration aware of the incident.

20) NLC (073970 – Assault Contact/Offensive/Provocative in Nature) On 04/29/2024 Officers were dispatched to the Brazos Student Union for a student who wanted to report they were assaulted. When the officers arrived, they met with the victim (a female student), who stated she was talking to some students, and they thought her name was "Jessica". She stated she advised them her name was not Jessica and that is when another student came up from behind her and grabbed her by the back of the neck. She stated she did not know who was behind her. The female refused EMS and stated she would be, "Ok." The female also stated she wished to pursue charges and was informed where and how to file charges for assault by contact. Campus administration was informed of the incident and is working with campus police for further student conduct discipline.

21) SAC (073993 – Assault Contact/Offensive/Provocative in Nature) On 04/30/2024, a female student approached an officer reporting another male student tried to kiss her three times and touched her chin with his fingers. She stated the incident occurred at the McAllister music hall near room 204. The officer informed the female how to self-file and where she could go to file assault by contact.

22) PAC (074001 – Criminal Trespass) On 04/30/2024 an officer was dispatched to the Ozuna library for a suspicious person who may be “vaping” in the restroom. When the officers arrived, they recognized the male from previous encounters and from a criminal trespass issued to him. The male arrested and transported to the Bexar County Adult Detention Center where he was booked for the criminal trespass.

SELECTED CLERY CRIMES	2023 TOTAL YEAR TO DATE	2024 TOTAL YEAR TO DATE	PCT Change	
Theft / Larceny	23	20	↓	13%
Burglary Vehicle	5	7	↑	40%
Burglary	2	3	↑	50%
Robbery	0	1	↑	100%
Motor Vehicle Theft	0	4	↑	400%
Drug Law Arrests	12	18	↑	50%

CRIME PREVENTION REMINDERS ISSUED	2023 TOTAL YEAR TO DATE	2024 TOTAL YEAR TO DATE	PCT Change	
	431	73	↓	83%

Calls For Service Data (Reporting Month & YTD)

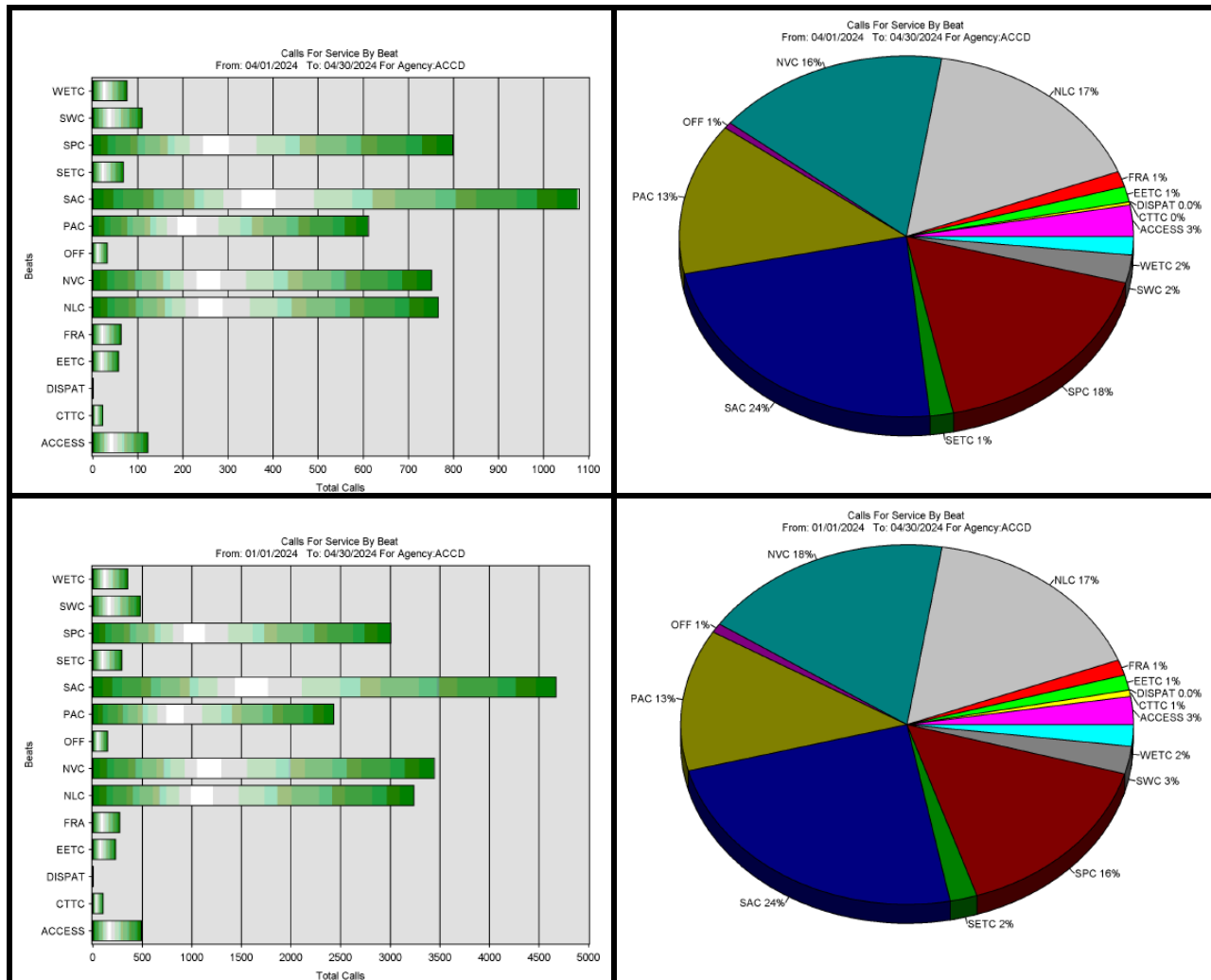

Discussion and Possible Action on Approval of Report of Policies Reviewed with No Substantive Changes

Recommended for approval to the ALAMO COLLEGES DISTRICT BOARD OF TRUSTEES on May 21, 2024

MINUTE ORDER

“The Alamo Colleges District Board of Trustees hereby approves the report of Board Policies with no substantive changes as presented.”

PURPOSE

The following Report of Policies Reviewed with No Substantive Changes is presented to the Board of Trustees for informational and approval purposes.

BACKGROUND

Policy B.5.3 regarding Board Policies requires Policies be reviewed within a five-year period. Policy owner review plan responsibilities are to determine whether the policy is still relevant, accurate and lawful. Considerations should be whether: any pertinent law has changed since the last Board action; any new technology has made the policy or any portion thereof obsolete; or any new risks or priorities now exist that need to be addressed in the policy. The District Ethics, Compliance, and Policy Office may modify the review plan or initiate outside-cycle policy review at any time to address business needs, as applicable. Non-substantive edits or clarifications may also be made.

For policies which are reviewed in compliance with this review requirement but for which no substantive changes are recommended to the Board of Trustees, a notation will be made in its section review date, for example, “Reviewed 3-23-12.” While not required in Board Policy, a consent report has been developed summarizing policies reviewed with no substantive changes.

IMPLICATIONS

- Financial:** N/A
- Strategic Objective:** Goal III Performance Excellence
- Human Resources:** N/A

ATTACHMENT

Report of Policies Reviewed with No Substantive Changes for May 2024

Dr. Daphene Carson Date.
Director of Ethics, Compliance & Policy

Linda Boyer-Owens Date
Associate Vice Chancellor, Talent,
Organization & Strategic Innovation

Dr. Mike Flores Date
Chancellor





ALAMO
COLLEGES
DISTRICT

Board Policies Reviewed with No Substantive Change
May 21, 2024

Policy No.	Policy Title	Responsible Department	Review Date
Policy Section F: Students			
F.2.4	Student Financial Aid	Vice Chancellor for Finance and Administration	xx/xx/24
Policy Section C: Business and Support Services			
C.1.5	Purchasing and Acquisitions	Vice Chancellor for Finance and Administration	xx/xx/24

C.1.5 (Policy) Purchasing and Acquisitions

Responsible Department: Vice Chancellor for Finance and Administration

Board Adoption: 8-18-09

Last Board Action: 7-28-20, 9-15-20, 10-20-20; 8-16-22, x-xx24

Best Value

The Board seeks to accept the bid or proposal that represents the best value for the College District after considering all legally permissible factors in awarding a contract. This policy applies to the purchase of personal property, improvements to realty, goods or services. For additional construction-related procedures, see [C.2.3.4](#).

Purchasing Authority Delegation

The Board delegates to the Chancellor and to Purchasing & Contract Administration the authority to determine the method of purchasing pursuant to state law (excluding only Subchapters C (Construction Manager-Agent Method) and E (Design-Build Method) of Texas Government Code Chapter 2269, and to make budgeted purchases. The Chancellor or Purchasing & Contract Administration shall serve as hearing officer for proposer complaints regarding specifications or other elements of the procurement process. The Board of Trustees delegates authority to Purchasing & Contract Administration to award purchase orders and contracts up to \$200,000 in any 12-month period, subject to full compliance with all applicable Texas state procurement laws, Board policies, Alamo College procedures and any applicable grant or other funding requirements. The threshold for compliance with the competitive procurement requirements shall be as specified by Texas state procurement laws (currently \$50,000 in any rolling 12-month period), and the approval of purchases not expected to exceed \$200,000 for any twelve-month period are delegated to the Chancellor and Purchasing & Contract Administration.

Board-Awarded Purchases

Purchases over \$200,000 in any 12-month period must have the approval of the Board of Trustees. Purchasing & Contract Administration will prepare and submit a Minute Order for consideration and action by the Board of Trustees, through the office of the Vice Chancellor for Finance & Administration, with the concurrence from the Vice Chancellor or College President.

Competitive Purchases

Except for the exceptions stated in TEXAS EDUCATION CODE Section 44.031, all Alamo Colleges contracts for the purchase of goods and services, except contracts for the purchase of produce or vehicle fuel, valued at \$50,000 or more in the aggregate for each 12-month period shall be made by the method, of the following methods, that provides the best value for the District:

- (1) competitive bidding for services other than construction services;
- (2) competitive sealed proposals for services other than construction services;
- (3) a request for proposals, for services other than construction services;
- (4) an interlocal contract;
- (5) a method provided by Chapter 2269, Government Code, for construction services;
- (6) the reverse auction procedure as defined by Section 2155.062(d), Government Code; or
- (7) the formation of a political subdivision corporation under Section 304.001, Local Government Code.

C.1.5 (Policy) Purchasing and Acquisitions

Responsible Department: Vice Chancellor for Finance and Administration

Board Adoption: 8-18-09

Last Board Action: 7-28-20, 9-15-20, 10-20-20; 8-16-22, x-xx24

Competitive Purchase Specifications

Purchasing & Contract Administration shall ensure that the staff prepares detailed specifications for any competitive purchase, regardless of procurement method.

Competitive Procurement Evaluation

For purchases subject to competitive procurement requirements, the documents soliciting bids or proposals must identify weighted evaluation criteria. These criteria are determined at the discretion of the Purchasing & Contract Administration Department, in consultation with the using department and/or the selection committee and shall be relevant and material to properly evaluate a bid or proposal. For the purchase of goods and services other than construction and professional services, the evaluation criteria shall include best value concepts, which allow consideration of the overall combination of quality, price and other elements that in total are optimal relative to the needs of Alamo Colleges.

When best value analysis applies, it is District policy that cost should be given as much consideration as is reasonable, balancing price against the technical difficulty or expertise required to develop a bid or proposal for the purchase of General Goods or Services (automobiles, office supplies, tools). Criteria Weighting Guidelines are provided in Table 1.1. With the prior approval of the Vice Chancellor of Finance and Administration, a lesser percentage than listed in Table 1.1 may be applied toward price. The weight afforded to price should only be reduced when there is substantial uncertainty as to the nature of the statement of work or respondents are required to demonstrate extraordinary expertise in formulating and implementing the statement of work for the purchase of Specialized Goods or Highly Complex Services (software, financial services, banking services).

After considering price, Alamo Colleges may utilize, other than for construction, any of the following evaluation criteria in the tables below.

C.1.5 (Policy) Purchasing and Acquisitions

Responsible Department: Vice Chancellor for Finance and Administration

Board Adoption: 8-18-09

Last Board Action: 7-28-20, 9-15-20, 10-20-20; 8-16-22, x-xx-24

TABLE 1.1: CRITERIA WEIGHTING GUIDELINES (EXCLUDING CONSTRUCTION)	Select from the suggested evaluation point ranges for the purchase of General Goods or Services	Select from the suggested evaluation point ranges for the purchase of Specialized Goods or Highly Complex Services
Purchase price.	30-80	20-50
Reputation of the vendor and of the vendor's goods or services.	0-10	0-10
Quality of vendor's goods and services.	0-20	20-30
The extent to which the goods or services meet the district's needs.	20-30	20-30
The vendor's past relationship with the district.	0-10	0-10
The impact on the ability of the district to comply with laws and rules relating to historically underutilized businesses.	(currently no laws exist)	(currently no laws exist)
Total long-term cost to the district to acquire the vendor's goods or services.	0-10	0-30
Any other relevant factor specifically listed in the request for bids or proposals, including the Small, Minority, Women, Veteran Business Enterprise (SMWVBE) Subcontracting Plan	0-20	0-30
Whether the vendor or the vendor's ultimate parent company or majority owner: (A) has its principal place of business in this state; or (B) employs at least 500 persons in this state.	0-10	0-10

C.1.5 (Policy) Purchasing and Acquisitions

Responsible Department: Vice Chancellor for Finance and Administration

Board Adoption: 8-18-09

Last Board Action: 7-28-20, 9-15-20, 10-20-20; 8-16-22, x-xx-24

The listed criteria are the only criteria that may be considered by the College District in its decision to award a contract. The College District may apply one, some, or all of the criteria, but it may not completely ignore them.

For construction procurement, the College District will follow the procedures required by law, which presently appear at Texas Government Code Chapter 2269. The Board has authorized and delegated to the Chancellor its authority to select from amongst, the following construction methods for any particular construction project: Competitive Bidding; Competitive Sealed Proposal; Construction Manager-at-Risk; and Job Order Contracting. The Chancellor is authorized to sub-delegate the authority of law, presently set forth at Section 2269.55.

Sole Source Purchases

Without complying with requirements for Competitive Purchases in this policy, Alamo Colleges may purchase an item that is available from only one source, including:

- (1) an item for which competition is precluded because of the existence of a patent, copyright, secret process, or monopoly;
- (2) a film, manuscript, or book;
- (3) a utility service, including electricity, gas, or water; and
- (4) a captive replacement part or component for equipment.

The Sole Source purchase exceptions do not apply to mainframe data-processing equipment and peripheral attachments with a single-item purchase price in excess of \$15,000.

Professional Services

The competitive procurement requirements do not apply to a contract for professional services rendered, including services of an architect, attorney, certified public accountant, engineer, or fiscal agent. Alamo Colleges may, at its option, contract for professional services rendered by a financial consultant or a technology consultant in the manner provided by Section 2254.003, Government Code, in lieu of the methods provided. Professional services are not exclusively defined by TEXAS EDUCATION CODE Section 44.031 or TEXAS GOVERNMENT CODE Chapter 2254, and the contracting requirements of that latter section apply only to the professions therein listed, those being:

- (i) accounting;
- (ii) architecture;
- (iii) landscape architecture;
- (iv) land surveying;
- (v) medicine;
- (vi) optometry;
- (vii) professional engineering;
- (viii) real estate appraising; or
- (ix) professional nursing.

C.1.5 (Policy) Purchasing and Acquisitions

Responsible Department: Vice Chancellor for Finance and Administration

Board Adoption: 8-18-09

Last Board Action: 7-28-20, 9-15-20, 10-20-20; 8-16-22, x-xx-24

Receipt of Electronic Bid or Proposal Responses

Purchasing & Contract Administration shall adhere to rules to ensure security and confidentiality for receiving Bids or Proposal through electronic transmission pursuant to Texas Education Code Section 44.0313, which shall ensure that the electronic bids or proposals remain effectively unopened until the time identified within the solicitation. Purchasing and Contract Administration shall determine the circumstances under which paper responses will be accepted consistent with the requirements of applicable law.

Change Orders

If a change in plans or specifications is necessary after the performance of a contract is begun or if it is necessary to decrease or increase the quantity of work to be performed or of materials, equipment, or supplies to be furnished, Purchasing & Contract Administration may approve change orders making the changes. The total contract price may not be increased because of the changes unless additional money for increased costs is in the budget for that purpose from available money or is provided for by the authorization of the issuance of time warrants.

Purchases or contracts approved by the Board with an amount of \$200,000 - \$999,999: Purchasing & Contract Administration is delegated authority to change executed purchase orders or contracts, except that prior Board approval is required for any change order or amendment providing for an increased District financial commitment that causes the total of all increases since the original or most recent Board-approved amount to exceed \$200,000. These principles shall not apply only if authority to exceed the approved amount is expressly delegated by the Board or an exception is expressly adopted by the Board for that contract.

A contract with an original contract price of \$1 million or more may not be increased by more than 25 percent without a redetermination of whether competitive procurement must be performed. If a change order for a contract with an original contract price of less than \$1 million increases the contract amount to \$1 million or more, the total of the subsequent change orders may not increase the revised contract amount by more than 25 percent of the original contract price. Board delegation, exception or approval is not sufficient under these circumstances.

Communication with Contractors, Consultants, and Other Vendors

From the date the project is approved for publication until a contract is executed, no College District Board member or employee other than authorized Purchasing & Contract Administration personnel shall communicate with potential contractors, consultants, or other vendors (referred to collectively as potential proposers/bidders) who are interested in, or in the view of a reasonable person situated similarly to the potential proposer/bidder, might reasonably become interested in, any non-construction competitive procurement opportunity. Rules governing communication for construction-related procurement opportunities are found in

C.1.5 (Policy) Purchasing and Acquisitions

Responsible Department: Vice Chancellor for Finance and Administration

Board Adoption: 8-18-09

Last Board Action: 7-28-20, 9-15-20, 10-20-20; 8-16-22, x-xx-24

C.2.3.4.

Responsibility for Debts

The Board shall assume responsibility for debts incurred in the name of the College District so long as those debts are for purchases made in accordance with adopted Board Policy and current administrative procedures. Persons making unauthorized purchases may be responsible for all such debts.

Authorized Purchases

Unless state law or Board policy requires the Board to make or approve a purchase, authorized College District employees in charge of a department or college budget may requisition Purchasing & Contract Administration to purchase items included in their approved budget, in accordance with administrative procedures.

Exclusive Purchase Commitments & Contract Execution Authority

All purchase commitments shall be memorialized by the Chancellor or Purchasing & Contract Administration on a properly drawn and issued purchase order or agreement approved in accordance with administrative procedures. Purchasing & Contract Administration is delegated exclusive signature authority for all vendor transaction agreements, other than the retention and compensation of outside counsel by the Office of Legal Services as provided for in Policy [B.7.2](#). Centralizing the contract signature authority for vendor purchases and agreements will reasonably assure the reliability of reporting, effectiveness, and compliance with applicable laws and policies.

Emergency Purchases

Emergency purchases as defined by Texas Education Code 44.031(h) must be approved by the Chancellor or Purchasing & Contract Administration prior to award and processed to ensure all requirements are met. All such purchases shall be presented to the Board of Trustees for ratification.

State and Cooperative Purchases

The Board authorizes the Chancellor or Purchasing & Contract Administration to approve state and cooperative contract purchases. Purchasing & Contract Administration shall report each such purchase of \$200,000 or more to the Board on a monthly basis.

Verifying Purchases

The Purchasing & Contract Administration shall establish procedures regarding the manner of verifying the quality, quantity, and physical condition of the materials received so that approval for payment may be established.

C.1.5 (Policy) Purchasing and Acquisitions

Responsible Department: Vice Chancellor for Finance and Administration

Board Adoption: 8-18-09

Last Board Action: 7-28-20, 9-15-20, 10-20-20; 8-16-22, x-xx-24

Detailed Purchasing Procedures

The Purchasing & Contract Administration shall supplement this policy with detailed purchasing procedures and instructions.

Small, Minority, Women, and/or Veteran-Owned Business Enterprises Program (SMWVBE)

It is the policy of Alamo Colleges to encourage the use of Small, Minority, Women, and/or Veteran-Owned Business Enterprises as herein below defined to assist in the implementation of this policy through race, ethnicity, and gender-neutral means. The purpose of this program is to ensure that SMWVBE's are provided the maximum practicable opportunity to participate in all purchasing and contracting opportunities.

“SMWVBE” means a company with a certification designation from an authorized certification agency as a small, minority or a woman group certification, such as a Historically Underutilized Business (HUB), or Minority Business Enterprise (MBE), or Women Business Enterprise (WBE), Small Business Enterprise (SBE), and/or Veteran Business Enterprise (VBE).

The Vice Chancellor for Finance and Administration will establish the Alamo Colleges Aspirational Goal for the SMWVBE Program based on an analysis of projected annual purchases and a survey of available SMWVBEs registered with the Alamo Colleges and/or the South Central Texas Certification Agency. The primary means for achieving the Aspirational Goal will be through race- and gender-neutral principles.

The SMWVBE Aspirational Goal will be reviewed annually by the SMWVBE Program Office. Any recommendations for adjustment will be submitted to the Vice Chancellor for Finance and Administration approval. Progress towards the Aspirational Goal will be reported annually to the Board of Trustees.

In addition, Alamo Colleges considers entering into a contract for the purchase of goods, services, construction services, or professional services with an expected value of \$50,000 or more shall, before soliciting bids, proposals, offers, or other applicable expressions of interest for the contract, determine whether there will be subcontracting opportunities under the contract. If the SMWVBE Program Office determines that there is that probability, the Purchasing & Contract Administration Department will incorporate the SMWVBE Subcontracting Plan requirements and evaluation criteria into the solicitation for bid, proposal, offer, or other applicable expression of interest.

Local Suppliers

There is no statutory authorization for the Alamo Colleges District to give consideration to a vendor in a competitive procurement due to the location of its principal place of business, as there is for cities and certain other local governments. The Alamo Colleges District will utilize the existing authority to advance the objective to the extent permissible.

C.1.5 (Policy) Purchasing and Acquisitions

Responsible Department: Vice Chancellor for Finance and Administration

Board Adoption: 8-18-09

Last Board Action: 7-28-20, 9-15-20, 10-20-20; 8-16-22, x-xx-24

Working together, Requisitioners and Purchasing & Contract Administration will assess purchase requirements for:

Competitive Purchases (\$50,000 or more) - establish minimum qualifications for awarding to local suppliers when service requirements require a local a provider (as with some maintenance or other services) due to response time, accessibility, etc.; and

Informal (under \$50,000) and COOP Purchases - select from local suppliers considering our requirements and vendor availability.

Procedure [C.1.5.1](#) Purchasing Authority

Legal Reference - TACC Policy Reference Manual

CF(LEGAL) - Purchasing and Acquisition

CFE(LEGAL) - Purchasing and Acquisition: Vendor Relations

CFF(LEGAL) - Purchasing and Acquisition: Payment Procedures

CFG(LEGAL) - Purchasing and Acquisition: Real Property and Improvements

CFH(LEGAL) - Purchasing and Acquisition: Financing Personal Property Purchases

F.2.4 (Policy) Student Financial Aid

Responsible Department: Vice Chancellor for Finance and Administration

Board Adoption: 5-19-09

Last Board Action: 12-13-22

Financial Aid Programs

The objective of the Alamo Colleges financial aid programs is to ensure that each of the Alamo institution's student financial aid programs provide assistance to students, who, without such assistance, may not be able to pursue higher education. Financial assistance at each institution may include, but is not limited to, loans, scholarships, grants, and employment. No student or prospective student shall be excluded from participation in or denied the benefits of any financial aid program at the institution on the basis of race, color, national origin, religion, sex (gender), disability, veteran status, or other protected criteria.

20 U.S.C. 1681 (Title IX); 42 U.S.C. 2000d (Title VI); 29 U.S.C. 794 (Section 504); 42 U.S.C. 12132 (Americans with Disabilities Act [ADA])

Code of Conduct

Staff of the Alamo Colleges Student Financial Aid Office shall abide by the Statement of Ethical Principles and Code of Conduct for Financial Aid Professionals as approved by the National Association of Student Financial Aid Administrators, March 2014 (NASFAA).

Statement of Ethical Principles

1. Advocate for students
2. Manifest the highest level of integrity
3. Support student access and success
4. Comply with federal and state laws
5. Strive for transparency and clarity
6. Protect the privacy of financial aid applicants

Code of Conduct

1. No action will be taken by staff that is for their personal benefit or could be perceived as a conflict of interest (see Conflict of Interest below).
2. Information provided by the financial aid office is accurate, unbiased, and does not reflect preference arising from actual or potential personal gain
3. Institutional award notifications and or other institutionally provided materials will include a breakdown of individual components, clear identification of each award, standard terminology and definitions, and renewal requirements for each award.
4. All required consumer information is displayed in a prominent location on their website.
5. Financial aid professionals will disclose to their institution any involvement, interest in, or potential conflict of interest with any entity with which the institution has a business relationship.

F.2.4 (Policy) Student Financial Aid

Responsible Department: Vice Chancellor for Finance and Administration

Board Adoption: 5-19-09

Last Board Action: 12-13-22

Conflict of Interest

No action will be taken by financial aid staff that is for their personal benefit or could be perceived to be a conflict of interest. Student Financial Aid staff will not process the records of or award aid to any current or former family members. Instead; these tasks shall be given to another designated staff member who is at least a Director or above to avoid the appearance of a conflict of interest.

Staff in the Student Financial Aid department are prohibited from personally awarding or approving financial aid for Alamo Colleges employees. Exceptions are made solely for those in the roles of Student Financial Aid Director or District Director.

Title III Matching Waiver

Title IV regulations (Part 606 of 34 CFR, Volume 6, Chapter 1, p 6-17 of 2012-2013 SFA Handbook) allow institutions that have been designated as Title III Hispanic Serving institutions to waive the 25% matching requirement for Federal College Work Study (FCWS) and Federal Supplemental Educational Opportunity Grant (FSEOG). The Texas Higher Education Coordinating Board also allows this waiver (Subchapter M, Section 21.405(b) in their Student Services Policy Manual. If and/or when Alamo Colleges is notified of this designation annually; it shall waive the matching requirement for these program awards and place an amount of funds equal to the 25% match, based on the current allocation, into a restricted multi-year fund. These funds are to be used as a reserve for the payment of student wages when the federal allocation of FCWS funds has been exhausted as payments to students or to provide additional support to needy students.

This section will not apply:

1. In any year when the Alamo Colleges does not receive the Title III Hispanic Serving institution designation.
2. If federal Title IV regulations are changed to prohibit the waiver.

Deposits to Multi-Year Fund:

1. Will be calculated annually.
2. Will vary based on the federal allocation.

Institutional and Financial Assistance Information

The Alamo College District shall follow applicable information dissemination and counseling requirements found at 20 U.S.C. 1092 including those concerning the following areas:

1. Financial assistance programs.
2. Exit counseling for borrowers.

F.2.4 (Policy) Student Financial Aid

Responsible Department: Vice Chancellor for Finance and Administration

Board Adoption: 5-19-09

Last Board Action: 12-13-22

-
3. Financial assistance information personnel.
 4. Athletically related student aid.
 5. Campus security policy and campus crime statistics
 6. Institutional policies and sanctions related to copyright infringement.

F.2.4 (Policy) Student Financial Aid

Responsible Department: Vice Chancellor for Finance and Administration

Board Adoption: 5-19-09

Last Board Action: 12-13-22

7. Man's and women's intercollegiate athletics.
20 U.S.C. 1092

Educational Lending

There shall be no conflict of interest with the responsibilities of an office, employee, or agent of the Alamo Colleges, including the provisions of Texas Association of Community Colleges described in 20 U.S.C 1094(e) regarding:

1. A ban on revenue-sharing arrangements;
2. A ban on gifts from lenders, guarantors, or servicers of educational loans;
3. A prohibition on certain interaction with borrowers;
4. A prohibition on offers of funds for private loans;
5. A ban on lender assistance with call center or financial aid office staffing;
and
6. A prohibition on advisory board compensation.

The District shall publish the code of conduct prominently on the District's Web site. The District shall also administer and enforce the code of conduct by, at a minimum, requiring that all of the District's officers, employees, and agents are informed annually of the provisions of the code of conduct.

20 U.S.C. 1094(a)(25) (e)

Discussion and Possible Action on Monthly Contracts Report

Presented to the Board Acting as Committee of the Whole on May 14, 2024, and now presented to the ALAMO COLLEGES DISTRICT BOARD OF TRUSTEES on May 21, 2024.

MINUTE ORDER

“The Alamo Colleges District Board of Trustees hereby approves this report on non-grant contracts (public) made to the Alamo Colleges District for the period of September 1, 2023, through April 30, 2024.”

PURPOSE

To provide a monthly report on non-grant contracts received by the Alamo Colleges District.

BACKGROUND

Contracts – Non-grant contracts are contracts in which Alamo Colleges District receives funds to provide special or negotiated services or training to private corporations. For the period ending April 30, 2024, there are a total of 19 contracts that total \$468,918.00 in external funding. This will allow services to be provided to 3,460 individuals.

OBJECTIVE/FACT

To supplement activities not funded by Institutional Funds.

IMPLICATIONS

Financial:	Yes
Strategic Plan:	Goal III. Performance Excellence
Human Resources:	Yes

ATTACHMENTS: YTD Contract (Non-Grant) Summary Report.

Dr. Sammi Morrill, Associate Vice Chancellor
of Operations, Economic Workforce Development

Xavier Urrutia, Interim Vice
Chancellor for Economic & Workforce
Development

Dr. Mike Flores, Chancellor

ALAMO COLLEGES DISTRICT
Year-To-Date Contract (Non-Grant) Summary Report
 Status: September 1, 2023 - August 31, 2024

I. Current Month Contracts District Wide:

No.	Contract Recipient (District Wide)	No. of Courses	Monthly No. Students to be Served	YTD No. Students to be Served
1	Workforce Training Network	19	379	3,460
	Total	19	379	3,460

II. Year-to-Date Number of Contracts in Selected Dollar Ranges:

No.	Contract Recipient	\$.01-\$9,999.99	\$10,000-\$100,000	\$100,000 and Higher	Total
1	Workforce Training Network	12	6	1	19
	Total	12	6	1	19

Source: All data provided by Workforce Training Network-Continuing Education Department.

ALAMO COLLEGES DISTRICT
FY2024 MONTHLY (MTD) GRANT AWARD ACTIVITY REPORT
 March 01, 2024-March 31, 2024

Item No.	Grant Code	College	Funding Source/Grant	Description/Function	Date of Award Letter	Match Amount	Indirect Cost	Funding Amount	Students Served	No. of FTEs
1	219180	District	Texas Workforce Commission, Project Title: "Adult Education and Literacy".	The AEL Consortium will lead the Adult Learner Success. Network in planning and designing education services, support services and workforce pathways across the 12 county Workforce Solutions Alamo board area with the goal of supporting adults in achieving their academic, career and life goals. Additional funding in the amount of \$56,012.	7/1/2023	\$0	\$0	\$56,012	69	5.00
	1		Total Dist.- MTD Single Year Grants			\$0	\$0	\$56,012	69	5.00
	1			Total MTD Single Year Grants		\$0	\$0	\$56,012	69	5.00
				Multi Year Grants						
1	213101	Palo Alto College	National Science Foundation thru Arizona State University, Project Title: "ALRISE Accelerate Latinx Representation in STEM Education with Institutional Intentionality and Capacity Building for Experiential Learning". Year 3 of 3.	The ALLRISE alliance is developing a network of faculty, staff, administrators and students at 2-yr and 4-yr Hispanic Serving Institution's and emerging HSIs to accelerate Latinx representation in science, technology, engineering and math STEM education.	8/1/2021	\$0	\$11,750	\$122,026	0	1.00
2	213103	Palo Alto College	U.S. Department of Education, Project Title: "Palo Alto College-CCAMPIS 2021". Year 3 of 4.	To meet the goal of providing 20 low-income student-parents success by providing access to high quality childcare, the project will subsidize the majority of the cost of child care to ensure that PAC students realize their full potential by enrolling, persisting and completing a college degree.	10/1/2023	\$0	\$0	\$155,215	20	0.00
	2		Total PAC-MTD Multi Year Grants			\$0	\$11,750	\$277,241	20	1.00
	2			Total MTD Multi-Year Grants		\$0	\$11,750	\$277,241	20	1.00
	3			GRAND TOTAL-MTD SINGLE AND MULTI-YEAR GRANTS		\$0	\$11,750	\$333,253	89	6.00

ALAMO COLLEGES DISTRICT

FY 2024 YTD Grant Award Summary Report

Includes All Single Year Grants and the Current Year of Multi-Year Grants

September 1, 2023 -March 31, 2024

No.	College	No. of Grants	Match Amounts	Indirect Cost Received	YTD Funding Amount	No. of Students Served	No. of FTEs
1	District Grants	7	\$ 498,385	\$ 42,646	\$ 4,318,384	5,644	22.00
2	San Antonio College	11	\$ 257,048	\$ 164,523	\$ 3,475,166	12,534	27.50
3	St. Philip's College	5	\$ -	\$ 20,516	\$ 11,516,865	28,682	29.00
4	Palo Alto College	9	\$ -	\$ 122,045	\$ 2,412,532	1,797	17.00
5	Northwest Vista College	5	\$ -	\$ 87,524	\$ 1,131,163	965	4.10
6	Northeast Lakeview College	4	\$ -	\$ 17,792	\$ 352,889	830	4
GRAND TOTAL		41	\$ 755,433	\$ 455,046	\$ 23,206,999	50,452	103.60

ALAMO COLLEGES DISTRICT
FY 2024 Monthly & YTD Grant Award Funding Activity Report with Award Description
September 1, 2023 -March 31, 2024

Item No.	Grant Code	College	Funding Source/Grant	Description/Function	Date of Award Letter	Match Amount	Indirect Cost	Funding Amount	Students Served	No. of FTEs
1	219368	District	Public Allies Inc., <u>Project Title:</u> "Public Allies San Antonio".	The purpose of this grant is to develop our ability to meet the needs of the community by increasing our opportunity to work with community based organization. The partnership with the organizations will help develop a cohort of young social service leaders who can facilitate transformational change leading to the improvement of their communities.	6/16/2023	\$498,385	\$24,770	\$495,690	25	3.00
2	219882	District	U.S. Department of Education thru Texas Higher Education Coordinating Board (THECB), <u>Project Title:</u> "Career and Technical Education-Basic Grants".	The Perkins Basic Grant Program supports awarded applicants in educating students who enroll in CTE courses and programs in preparation for high-skill, high-wage, or high-demand occupations. The success of an awarded application in educating these students will be measured by its ability to meet state-determined performance targets for each of three core indicators approved by the US. Department of Education/Office of Career, Technical and Adult education.	8/21/2023	\$0	\$0	\$2,562,390	4,000	6.00
3	219884	District	Texas Workforce Commission, <u>Project Title:</u> "Skills for Small Business Program".	The Skills for Small Business (SSB) program will provide training for small private businesses in the local area. Each participating business partner will select training courses for its new and/or existing employees that will contribute to the enhancement of the business's operation.	12/1/2023	\$0	\$0	\$89,250	50	0.00
3			Total Dist.- YTD Single Year Grants			\$498,385	\$24,770	\$3,147,330	4,075	9.00
1	211185	San Antonio College	Texas Higher Education Coordinating Board, <u>Project Title:</u> "The Texas Reskilling and Upskilling through Education (TRUE)".	Goal is to provide tuition resources for students to earn micro-credentials in LVN, RN and BSN medical program pathways. As the student continues medical training the potential for earning stackable credentials aligns to curriculum courses and leads to micro-credentials badges in 10 healthcare Teamwork, Therapeutic Communication, Healthcare Professionalism, Healthcare Cultural Competence, Critical Thinking.	1/8/2024	\$0	\$0	\$500,000	100	1.00
1			Total SAC-YTD Single-Year Grants			\$0	\$0	\$500,000	100	1.00
1	212101	St. Philip's College	Texas Higher Education Coordinating Board, <u>Project Title:</u> "Nursing & Allied Health Nursing Innovation Grant Program".	Goal of project, Nursing Faculty Resources and Professional Development, Recruitment and Retention on initial licensure students, Preparation and continual support of faculty and students for Next Generation NCLEX, Classroom Renovation.	8/1/2023	\$0	\$0	\$200,000	26	0.00
1			Total SPC YTD Single-Year Grants			\$0	\$0	\$200,000	26.00	0.00
1	215021	Northeast Lakeview College	University of Southern California Race and Equity Center, <u>Project Title:</u> "Men of Color Innovation Project".	Project will fund and provide technical support to 12 community colleges nationwide that are advancing initiatives to support men of color on their campuses. Funding will support curricular innovations, a cohort based learning community and professional development for NLC faculty and staff.	5/30/2023	\$0	\$0	\$75,000	30	0.00
1			Total NLC-YTD Single Year Grants			\$0	\$0	\$75,000	30	0.00
6			Total YTD Single Year Grants			\$498,385	\$24,770	\$3,922,330	4,231	10.00
			Multi-Year Grants							
1	219121	District	University of Texas at San Antonio, <u>Project Title:</u> "Bexar County Fostering Educational Success Pilot Program". Year 4 of 4.	To support students with foster or adoption experience.	9/1/2023	\$0	\$0	\$373,710	550	5.00

ALAMO COLLEGES DISTRICT
FY 2024 Monthly & YTD Grant Award Funding Activity Report with Award Description
September 1, 2023 -March 31, 2024

Item No.	Grant Code	College	Funding Source/Grant	Description/Function	Date of Award Letter	Match Amount	Indirect Cost	Funding Amount	Students Served	No. of FTEs
2	219166	District	<u>U.S. Department of Education, Project Title: "Alamo Colleges District Educational Opportunity Centers Program".</u> Year 3 of 5.	The ACD EOC project will provide counseling and information on college admissions to eligible adults who want to continue a program of postsecondary education. The ACD EOC project will also offer services to improve the financial economic literacy of participants, counsel participants on financial aid options and assist in the application process to increase the number of adults who enroll in postsecondary education institutions.	8/23/2021	\$0	\$17,876	\$241,332	850	3.00
3	219180	District	<u>Texas Workforce Commission, Project Title: " Adult Education and Literacy".</u>	The AEL Consortium will lead the Adult Learner Success. Network in planning and designing education services, support services and workforce pathways across the 12 county Workforce Solutions Alamo board area with the goal of supporting adults in achieving their academic, career and life goals. <i>Additional funding in the amount of \$56,012.</i>	7/1/2023	\$0	\$0	\$56,012	69	5.00
4	219190	District	<u>City of San Antonio, Project Title: "Compassionate Skills Education Development and Implementation".</u> Year 1 of 3. <i>Inadvertently reported 2x in January 2024 Board Report (removed duplicate entry).</i>	Compassionate USA is a people centered campaign promoting compassion, community healing and well being through the county. Provide free, accessible and relevant compassion education for everyone. Create a greater understanding and practice of community well being. Create a cultural shift towards compassion that reduces suffering and increases well-being.	9/29/2023	\$0	\$0	\$500,000	100	0.00
	4		Total Dist.-YTD Multi-Year Grants			\$0	\$17,876	\$1,171,054	1,569	13.00
1	211153	San Antonio College	<u>U.S. Department of Education, Project Title: "San Antonio College (SAC) Project R.I.S.E. (Ready, Inspired, Successful, Engaged) SSS Program".</u> Year 4 of 5.	The program will increase eligible students chances of success by providing year round tutoring and prescribed tutoring plans, academic and college readiness instruction, advice and assistance with postsecondary course selection. Each participant will establish an individual education plan that includes timelines to achieve graduation.	8/11/2020	\$0	\$16,341	\$272,354	120	5.00
2	211154	San Antonio College	<u>U.S. Department of Education, Project Title: "San Antonio College (SAC)'s Project Veterans Achieving Learning through Opportunity and Resilience (VALOR) SSS Program".</u> Year 4 of 5.	This program will increase eligible students' chances of success by providing year round tutoring and prescribed tutoring plans, academic and college readiness instruction, advise and assistance with postsecondary course selection, personal counseling for financial, academic and personal matters. Program proposes to serve at least 120 low income, first generations and/or disabled veterans each year through project VALOR.	8/11/2020	\$0	\$16,335	\$272,257	120	5.00
3	211160	San Antonio College	<u>City of San Antonio, Project Title: "Educational Access Channel".</u> Year 5 of 5.	Goal of the Educational Access Channel is to provide educational programming to the citizens of San Antonio and surrounding areas. Objectives-to provide cable/video at least 8 hours of daily educational programming, 365 days a year, provide transmissions of educational programming to cable/video providers in a manner that can be accepted and transmitted and communicate with designated city staff regularly.	10/1/2023	\$0	\$0	\$200,000	10,000	0.00

ALAMO COLLEGES DISTRICT
FY 2024 Monthly & YTD Grant Award Funding Activity Report with Award Description
September 1, 2023 -March 31, 2024

Item No.	Grant Code	College	Funding Source/Grant	Description/Function	Date of Award Letter	Match Amount	Indirect Cost	Funding Amount	Students Served	No. of FTEs
4	211169	San Antonio College	<u>U.S. Department of Education, Project Title: "San Antonio College's 2021 Child Care Access Means Parents in School (CCAMPIS) Program"</u> . Year 3 of 4.	Goal is to increase low-income student success by providing access to high-quality child care. At least 56 children of low-income SAC students will be provided with high quality child care each fall, spring and summer semesters. Project Director of Student Success will provide academic support counseling for CCAMPIS parents at risk for failure. By the end of each Fall, Spring and Summer semesters at least 90% of CCAMPIS parents will have completed all required workshops/volunteer hours.	10/1/2023	\$257,048	\$48,730	\$404,863	60	4.00
5	211172	San Antonio College	<u>U.S. Department of Education, Project Title: "San Antonio College's Access and Learning for Advancement and Success (ALAS) Upward Bound Project"</u> . Year 2 of 5.	The ALAS UB project will provide academic and supportive services to a cohort of 56 participants enrolled at Burbank High School with significant support from the applicant and community. Need for the project, education attainment levels of adults in the target area is low, target high school drop out rates are high. Will provide activities and supportive services to promote college enrollment and graduation.	6/1/2023	\$0	\$22,300	\$305,386	56	4.50
6	211174	San Antonio College	<u>U.S. Department of Education, Project Title: "San Antonio College's Upward Bound Math and Science Program Project at Highlands High School"</u> . Year 2 of 5.	Upward Bound Math and Science provides student services programs for individuals from disadvantages backgrounds, first generation, low-income individuals etc. UBMS provides up to four years of additional academic support through summer instruction in math, language arts, composition, foreign language and lab science with the curricula that aligns with state exams and state readiness standard.	9/1/2023	\$0	\$24,755	\$309,436	60	1.00
7	211176	San Antonio College	<u>U.S. Department of Education, Project Title: "San Antonio College's Project Apoyo"</u> . Year 2 of 5.	The HSI project Apoyo will serve as a catalyst for long-term improvements that will address disproportionately low rates at which Hispanic and other low-income students achieve, persist and succeed at San Antonio College. The grant will help institutions capacity to provide the guidance, engagement and academic support Hispanic and low-income students need to succeed in higher education.	10/1/2023	\$0	\$0	\$599,355	1,500	3.00
8	211177	San Antonio College	<u>National Science Foundation, Project Title: "HSI Pilot Project: San Antonio College's Campeones de STEM"</u> . Year 2 of 4.	The Project is designed to directly enhance STEM educational experiences and retention of first year of college students in STEM fields through experiential learning opportunities that engage undergraduate students with leaders and professionals in the greater San Antonio STEM Ecosystem.	8/9/2022	\$0	\$11,308	\$102,097	12	2.00
9	211183	San Antonio College	<u>Texas Higher Education Coordinating Board, Project Title: "Nursing & Allied Health Nursing Innovation Grant Program"</u> . Year 1 of 2.	Grant will compensate the cost for hiring a Personal Counselor. Counselor will provide counseling services to nursing students by assisting and supporting students through the nursing program.	8/5/2023	\$0	\$0	\$200,000	450	1.00
10	211184	San Antonio College	<u>U.S. Department of Education, Project Title: "San Antonio College's Upward Bound Math and Science Program Project at Edison High School"</u> . Year 1 of 5.	UBMS provides student services programs for individuals from disadvantage backgrounds, first-generations, low-income individuals. UBMS provides up to four years of additional academic support through summer instruction in math, language arts, composition, foreign language and lab science with the curricula that aligns with state exams and state readiness standards.	9/1/2023	\$0	\$24,753	\$309,418	56	1.00
	10		Total SAC-YTD Multi-Year Grants			\$257,048	\$164,523	\$2,975,166	12,434	26.50

ALAMO COLLEGES DISTRICT
FY 2024 Monthly & YTD Grant Award Funding Activity Report with Award Description
September 1, 2023 -March 31, 2024

Item No.	Grant Code	College	Funding Source/Grant	Description/Function	Date of Award Letter	Match Amount	Indirect Cost	Funding Amount	Students Served	No. of FTEs
1	212093	St. Philip's College	<u>National Science Foundation, Project Title:</u> "Project Sure: Scaffolding Undergraduate Research Experiences". Year 3 of 4.	Project SURE will target three areas: Innovation in Instruction, will incorporate STEM experiential learning and further develop faculty use of emerging experiential learning methods. Internship and Research Experience, will create alliances between the college and local industry to provide paid internship opportunities, and prepare students to apply for national research experiences and federal internship opportunities. Transfers, will center on guiding students to transfer to universities to complete their undergraduate degrees.	8/15/2023	\$0	\$20,516	\$312,498	120	1.00
2	212098	St. Philip's College	<u>U.S. Department of Education, Project Title:</u> "St. Philip's College Means Parents in School Program". Year 2 of 4.	Goal of the project is to provide support for the participation of low-income parents in postsecondary education through the provision of campus-based child care services offered at the on-site national accredited SPC Child Development Center. Aim of the project is to reduce the financial burden of Program participants and afford them the opportunity to enroll in school, persist in their chosen fields of study and ultimately graduate.	7/26/2023	\$0	\$0	\$281,389	40	2.00
3	212628	St. Philip's College	<u>U.S. Department of Education, Project Title:</u> "Historically Black Colleges and Universities Program: Fostering Undergraduate Talent by Unlock Resources for Education (FUTURE Act)". Year 4 of 5.	St. Philips College (SPC) will utilize its FUTURE Act grant award to implement and operate three activities that will support and strengthen the overall institution's delivery of services to students. The funds allocated are being used to support the following three (3) legislative Allowable activities. 1. Project Administration and Research Development, 2. Campus renovation & Technology Improvements, 3. Student Services.	4/19/2023	\$0	\$0	\$1,431,220	14,248	13.00
4	212639	St. Philip's College	<u>U.S. Department of Education, Project Title:</u> "Historically Black Colleges and Universities Program". Year 2 of 5.	St. Philip's College will serve its diverse student body by enhancing and operating seven legislative allowable activities over the five year grant cycle. 1. Project Administration and Research Development, 2. Centers of Excellence in Mathematics and Science, (3) Capital Improvements, (4) Information and Community Technology, (5) Institute for Teaching Excellence and Staff Development, (6) Student Services, (7) Good Samaritan Veterans Outreach and Transition Center.	10/1/2023	\$0	\$0	\$9,291,758	14,248	13.00
4			Total SPC-YTD Multi-Year Grants			\$0	\$20,516	\$11,316,865	28,656	29.00
1	213093	Palo Alto College	<u>U.S. Department of Education, Project Title:</u> "Palo Alto College SSS Project". Year 4 of 5.	Project will provide participants with academic support, tutoring and advising, information on financial aid assistance, financial literacy, career exploration. The need for the project in the target area is apparent due to the high percentage of the low-income, first-generation and disabled participants enrolled who are eligible for student support.	9/1/2023	\$0	\$18,491	\$272,364	140	2.00
2	213094	Palo Alto College	<u>U.S. Department of Education, Project Title:</u> "Palo Alto College DHSI: Project Listo". Year 4 of 5.	The goal of the project will be 1. Academic programs, provide support to facilitate success of students academic goals. 2. Institutional Management to implement improved academic support, advising, teaching and communication strategies that will increase student engagement and success. 3. Fiscal stability to increase revenue by enrolling and retaining more students.	10/1/2023	\$0	\$0	\$430,263	500	5.00

ALAMO COLLEGES DISTRICT
FY 2024 Monthly & YTD Grant Award Funding Activity Report with Award Description
September 1, 2023 -March 31, 2024

Item No.	Grant Code	College	Funding Source/Grant	Description/Function	Date of Award Letter	Match Amount	Indirect Cost	Funding Amount	Students Served	No. of FTEs
3	213099	Palo Alto College	<u>U.S. Department of Education, Project Title: "Palo Alto College Talent Search: Southwest High School"</u> . Year 3 of 5.	The TRIO Talent Search: Southwest ISD project will provide participants with academic support in tutoring and advising; information on financial literacy; financial aid programs; completing financial aid applications and support applying to college.	9/1/2023	\$0	\$20,572	\$288,470	500	3.00
4	213101	Palo Alto College	<u>National Science Foundation thru Arizona State University, Project Title: "ALRISE Accelerate Latinx Representation in STEM Education with Institutional Intentionality and Capacity Building for Experiential Learning"</u> . Year 3 of 3.	The ALLRISE alliance is developing a network of faculty, staff, administrators and students at 2-yr and 4-yr Hispanic Serving Institution's and emerging HSIs to accelerate Latinx representation in science, technology, engineering and math STEM education. <i>Additional Funding in the amount of \$122,026..</i>	8/1/2021	\$0	\$0	\$162,526	0	0.00
5	213102	Palo Alto College	<u>U.S. Department of Education, Project Title: "Palo Alto College Talent Search: South San and Somerset ISD"</u> . Year 3 of 5.	The PAC Talent Search project will provide participants with academic tutoring and advisement information on financial aid programs, assistance in completing financial aid application, financial literacy and support for applying for college enrollment.	10/1/2023	\$0	\$23,078	\$288,470	500	3.00
6	213103	Palo Alto College	<u>U.S. Department of Education, Project Title: "Palo Alto College-CCAMPIS 2021"</u> . Year 3 of 4.	To meet the goal of providing 20 low-income student-parents success by providing access to high quality childcare, the project will subsidize the majority of the cost of child care to ensure that PAC students realize their full potential by enrolling, persisting and completing a college degree.	10/1/2023	\$0	\$0	\$155,215	20	0.00
7	213109	Palo Alto College	<u>U.S. Department of Education, Project Title: "Palo Alto College Upward Bound Math Science Project"</u> . Year 2 of 5.	Palo Alto College (PAC) Upward Bound Math and Science (UBMS) will provide participants from East Central High School with academic instruction, tutoring and advising, information on financial aid programs, assistance in completing financial aid applications; financial literacy and support for applying for college enrollment.	9/1/2023	\$0	\$21,584	\$309,505	60	2.00
8	213110	Palo Alto College	<u>U.S. Department of Education, Project Title: "Palo Alto College Upward Bound"</u> . Year 2 of 5.	Palo Alto College (PAC) Upward Bound will provide participants from Poteet, Pleasanton, Lytle and Jourdanton High Schools with academic instruction, tutoring and advising information on financial aid applications, financial literacy and support for college enrollment.	9/1/2023	\$0	\$38,320	\$380,719	77	2.00
9	213114	Palo Alto College	<u>Texas Higher Education Board, Project Title: "Texas Reskilling and Upskilling through Education (TRUE)"</u> .	The TRUE grant supports the Innovative methods for promoting advanced certification and training (IMPACT) project, a collaborative initiative between Northeast lakeview College and Palo Alto College. IMPACT will create, redesign and expand short-term training programs in Logistics, Advanced Manufacturing and Welding degree programs. <i>Note: The TRUE grant is shared between NLC and PAC.</i>	12/6/2023	\$0	\$0	\$125,000	0	0.00
9			Total PAC-YTD Multi-Year Grants			\$0	\$122,045	\$2,412,532	1,797	17.00
1	214055	Northwest Vista College	<u>U.S. Department of Education, Project Title: "Portal Learning to Undergraduate Success in Science, Technology, Engineering & Math Project (PLUS+STEM Project)"</u> . Year 3 of 5.	The PLUS+STEM Project aims to narrow the STEM achievement gap among NVC's Hispanics, low-income and other disadvantages student groups, through the implementation of enhanced research based activities and services and equitable academic and support services that will empower underrepresented students with the skills and knowledge to succeed in STEM.	9/17/2021	\$0	\$72,087	\$999,896	190	1.30

ALAMO COLLEGES DISTRICT
FY 2024 Monthly & YTD Grant Award Funding Activity Report with Award Description
September 1, 2023 -March 31, 2024

Item No.	Grant Code	College	Funding Source/Grant	Description/Function	Date of Award Letter	Match Amount	Indirect Cost	Funding Amount	Students Served	No. of FTEs
2	214056	Northwest Vista College	National Science Foundation thru St. Mary's University, <u>Project Title: "FUERTE Project: Fostering Undergraduate Education, Retention & Transfer Environments"</u> . Year 3 of 5.	The NSF FUERTE Project, a partnership between Northwest Vista College (NVC) and St. Mary's University aims to build a collaborative culturally responsive transfer pathways in undergraduate education at Hispanic-Servicing Institutions to increase retention and graduation rates of Latinx students pursuing degrees in STEM. Aligning courses and curriculum between the institutions; providing professional development for faculty and staff and providing a holistic supporting system that will adapt best evidence-based support practices to Latinx students.	8/2/2021	\$0	\$12,165	\$41,125	50	0.30
3	214058	Northwest Vista College	National Science Foundation thru University of Texas at San Antonio, <u>Project Title: "GP-UP: Geoscience Engagement: Growing Interest at Hispanic Serving Institutions by Scaffolding Classroom Intervention to Service-Learning Projects"</u> . Year 3 of 5.	Goal of project is to broaden participation and enhance retention in the geosciences by testing the effectiveness of an integrated early intervention strategy within the undergraduate degree pipeline. Objective is to deploy a suite of activities in introductory science courses to establish an integrative understanding of how to attract more diverse non-majors to the discipline and employ a two-stage service learning strategy to articulate the critical elements and benefits of geoscience driven service learning projects for increasing retention.	6/1/2023	\$0	\$3,272	\$23,012	275	1.00
4	214059	Northwest Vista College	Texas Higher Education Coordinating Board (THECB), <u>Project Title: "2023 College Readiness and Success Models"</u> . Year 1 of 4.	Key action items for the NVC CRSM-2023 grant project are: 1. Implement an intrusive Advising Model for FTIC students in corequisite English and Math courses. 2. Implement culturally-responsive curriculum and supports for English language. 3. Increase support for new full-time and part-time faculty teaching corequisite courses through sustained professional development.	8/8/2023	\$0	\$0	\$50,000	300	1.00
5	214060	Northwest Vista College	U.S. Department of Health and Human Services thru Healthy Futures of Texas. <u>Project Title: "Talk About It Texas Project (TAIT Project)"</u> . Year 1 of 5.	The Talk About It Texas project will cultivate and leverage partnerships in San Antonio, Dallas, and the Rio Grande Valley to implement programs and establish and/or support linkages to care networks. The goal of the initiative is to improve sexual and reproductive health outcomes, promote positive youth development and advance health equity for adolescents, their families and communities through the replication of medically accurate and age-appropriate evidence based teen pregnancy prevention programs.	6/15/2023	\$0	\$0	\$17,130	150	0.50
5 Total NVC-YTD Multi-Year Grants						\$0	\$87,524	\$1,131,163	965	4.10
1	215015	Northeast Lakeview College	U.S. Department of Agriculture thru UTSA, <u>Project Title: "ECO-JEDI: Building a City-Wide Collaboration to Facilitate Career Readiness in FAS through Science & Counter-Storytelling"</u> . Year 2 of 4.	Project seeks to increase recruitment, graduation and career readiness by diminishing barriers and prioritizing diversity and inclusion of UP in science, technology, engineering and mathematics (STEM) through a city-wide collaboration of three HSIs. Will increase UP skills, investment and motivation in FAS individuals and communities in order to recruit students for USDA related jobs.	9/1/2023		\$17,792	\$53,133	600	1.00
2	215020	Northeast Lakeview College	Texas Higher Education Coordinating Board (THECB), <u>Project Title: "2023 College Readiness and Success Models"</u> . Year 1 of 4.	The College Readiness and Success Models (CRSM-2023) grant supports the creation of an NLC developmental educational advisory committee to oversee the implementation of a multiple measures assessment placement protocol for high school compete students and associated faculty training. CRSM-2023 also provides direct student support in the expansion of the College's calculator loan program embedded tutorial, and academic boot camp initiatives.	7/28/2023	\$0	\$0	\$99,756	150	0.00

ALAMO COLLEGES DISTRICT
FY 2024 Monthly & YTD Grant Award Funding Activity Report with Award Description
September 1, 2023 -March 31, 2024

Item No.	Grant Code	College	Funding Source/Grant	Description/Function	Date of Award Letter	Match Amount	Indirect Cost	Funding Amount	Students Served	No. of FTEs
3	215022	Northeast Lakeview College	Texas Higher Education Board, <u>Project Title: "Texas Reskilling and Upskilling through Education (TRUE)".</u>	The TRUE grant supports the Innovative methods for promoting advanced certification and training (IMPACT) project, a collaborative initiative between Northeast lakeview College and Palo Alto College. IMPACT will create, redesign and expand short-term training programs in Logistics, Advanced Manufacturing and Welding degree programs. <i>Note: The TRUE grant is shared between NLC and PAC.</i>	12/06.2023	\$0	\$0	\$125,000	50	3.00
	3		Total NLC-MTD Multi Year Grants			\$0	\$17,792	\$277,889	800	4.00
	35			Total YTD Multi-Year Grants		\$257,048	\$430,276	\$19,284,669	46,221	93.60
	41			GRAND TOTAL-YTD SINGLE AND MULTI-YEAR GRANTS		\$755,433	\$455,046	\$23,206,999	50,452	103.60

ALAMO COLLEGES DISTRICT
FY 2024 Monthly (MTD) Restricted Contract Activity Report
 March 01, 2024-March 31, 2024

Item No.	Grant Code	College	Funding Source / Grant	Description/Function	Date of Award Letter	Match Amount	Indirect Cost	Funding Amount	Students Served	No. of FTEs
1	249042	District	Alamo Colleges Foundation, <u>Project Title: "Toyota Finish Line Grant"</u> .	Funds are a way to incentivize participation in the Ready to Work program. This is to incentivize post-training and job placement reporting.	10/2/2023	0	0	\$26,765	133	0.0
	1		Total Dist.-MTD Restricted Grants			\$0	\$0	\$26,765	133	0.00
1	241018	San Antonio College	Hispanic Association of Colleges and Universities (HACU), <u>Project Title: "HACU/Grow with Google HIS Career Readiness Program"</u> . Year 2 of 2.	The Student Enrichment Center will use the requested funding to support a dedicated Grow with Google program cohort of 250 students targeting the College's first time in college student population.	10/19/2023	\$0	\$0	\$12,761	250	0.00
	1		Total SAC MTD Restricted Contracts			\$0	\$0	\$12,761	250	0.00
1	212651	St. Philip's College	P16 Plus Council of Greater Bexar County/UP Partnership. <u>Project Title: "UP Partnership Equitable Enrollment Collaborative Grant"</u> .	Goal of the grant project is to forge meaningful relationships and maintain routine contact with current partners and potential allies to explore ways to increase enrollment of Boys and Young Men of Color and Dreamer students. Through this initiative SPC may offer assistance to men of color who need tuition or instructional material support.	1/1/2022	\$0	\$0	\$6,000	250	0.0
	1		Total SPC MTD Restricted Contracts			\$0	\$0	\$6,000	250	0.00
1	243011	Palo Alto College	Hispanic Association of Colleges and Universities (HACU), <u>Project Title: "HACU/Grow with Google HIS Career Readiness Program"</u> . Year 2 of 2.	The PAC GwG program is a program designed to help students develop digital skills to help with ensuring career success. Special efforts will be made for the following student populations. Pre-enrolled students, Business, IT and Art pathway students, AlamoPromise and students enrolled in continuing education courses and pursuing GED.	10/19/2023	\$0	\$0	\$12,761	1,500	0.00
	1		Total PAC-MTD Restricted Contracts			\$0	\$0	\$12,761	1,500	0.00
1	245013	Northeast Lakeview College	Ellucian Foundation, <u>Project Title: "The Progress, Accomplishment, Thriving, Hope (PATH) Scholarship Program"</u> .	The PATH block grant provides scholarships to NLC students to address basic need insecurity. Scholarships support students experiencing economic hardships with an emphasis on mitigating barriers to enrollment.	8/11/2023	\$0	\$0	\$25,000	25	0.00
	1		Total NLC MTD Restricted Contracts			\$0	\$0	\$25,000	25	0.00
	5		GRAND TOTAL-MTD RESTRICTED CONTRACTS			\$0	\$0	\$83,286	2,158	-

ALAMO COLLEGES DISTRICT
FY 2024 YTD Restricted Contract (Non-Grant) Summary Report
September 1, 2023 -March 31, 2024

No.	Contract Recipient	No. of Contracts Executed for the Year	YTD Total Amount of Contracts	No. Students to be Served
1	District Restricted Contracts	4	\$209,195	185
2	San Antonio College	3	228,577	1,990
3	St. Philip's College	3	133,000	450
4	Palo Alto College	2	362,761	2,530
5	Northwest Vista College	1	142,630	1
6	Northeast Lakeview College	2	167,630	72
	Total	15	\$1,243,793	5,228

Year-to-Date Number of Contracts in Selected Dollar Ranges:

No.	Contract Recipient	\$.01-\$9,999.99	\$10,000- \$99,999	\$100,000 and Higher	Total
1	District Restricted Contracts		3	1	4
2	San Antonio College		2	1	3
3	St. Philip's College	1	1	1	3
4	Palo Alto College		1	1	2
5	Northwest Vista College			1	1
6	Northeast Lakeview College		1	1	2
	Total	1	8	6	15

Discussion and Possible Action on Approval of Construction Reports

Presented to the Board acting as Committee of the Whole on May 14, 2024 and now presented to the ALAMO COLLEGES DISTRICT BOARD OF TRUSTEES on May 21, 2024.

MINUTE ORDER

“The Alamo Colleges District Board of Trustees hereby approves the construction reports as presented.”

PURPOSE

The following construction reports are presented to the Board of Trustees for informational and approval purposes.

BACKGROUND

1. 2017 Capital Improvement Program Overview Chart(s)
2. 2017 CIP General Obligation Bond / Maintenance Tax Note Summary and Detail Report

IMPLICATIONS

Financial: N/A

Strategic Plan: Strategic Objective III Performance Excellence

Human Resources: N/A

ATTACHMENTS: Construction Reports

Lisa Mazure, MSA, CPA
Associate Vice Chancellor for
Finance and Fiscal Services

Dr. Thomas Cleary
Interim Vice Chancellor of Finance and
Administration

Dr. Mike Flores, Chancellor



ALAMO
COLLEGES
DISTRICT

BUDGET VS ACTUAL - OVERVIEW (GO & MTN)
(\$ FIGURES IN MILLIONS)

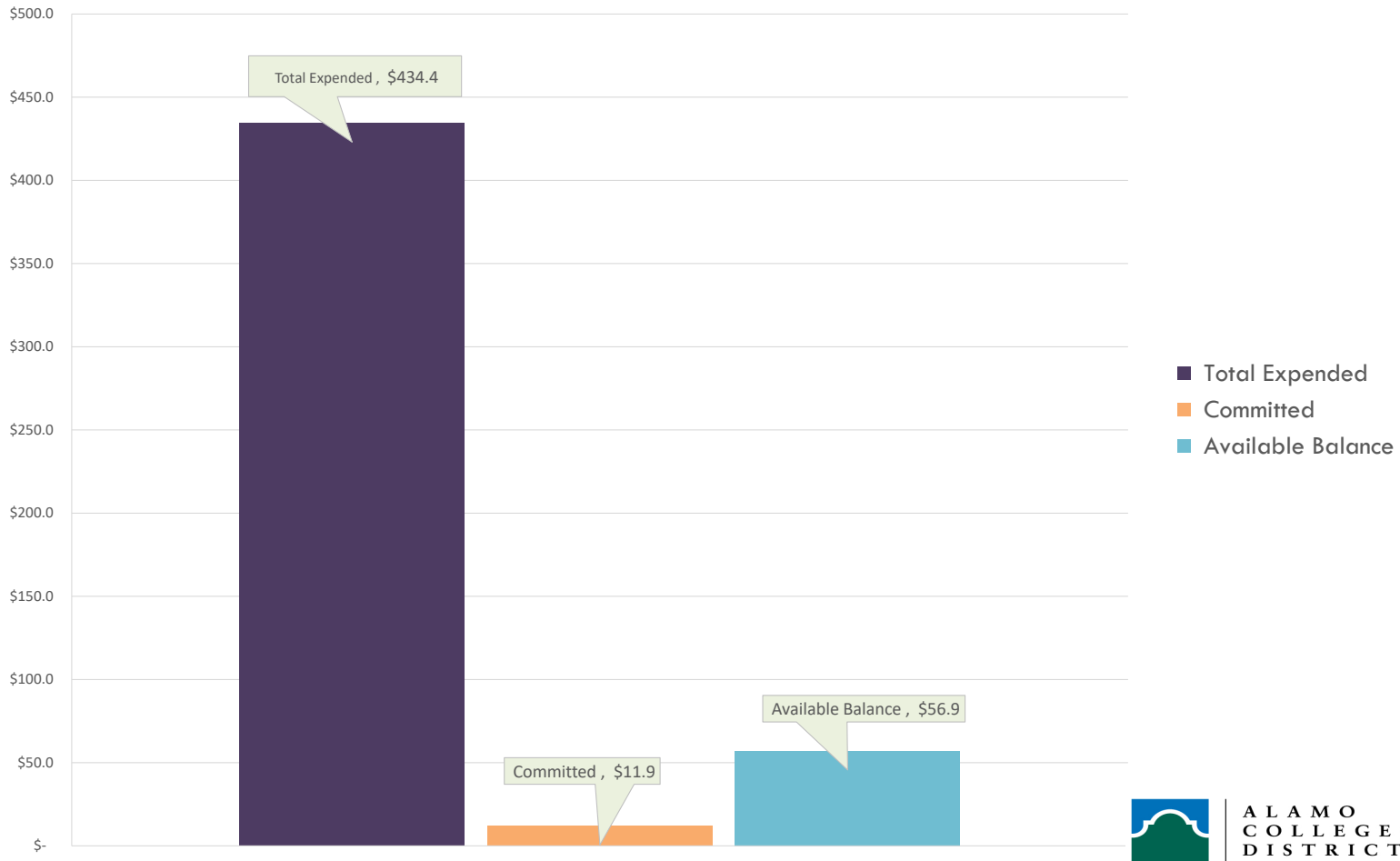

Alamo Colleges District Capital Improvement Program - Chart Summary As of March 31, 2024

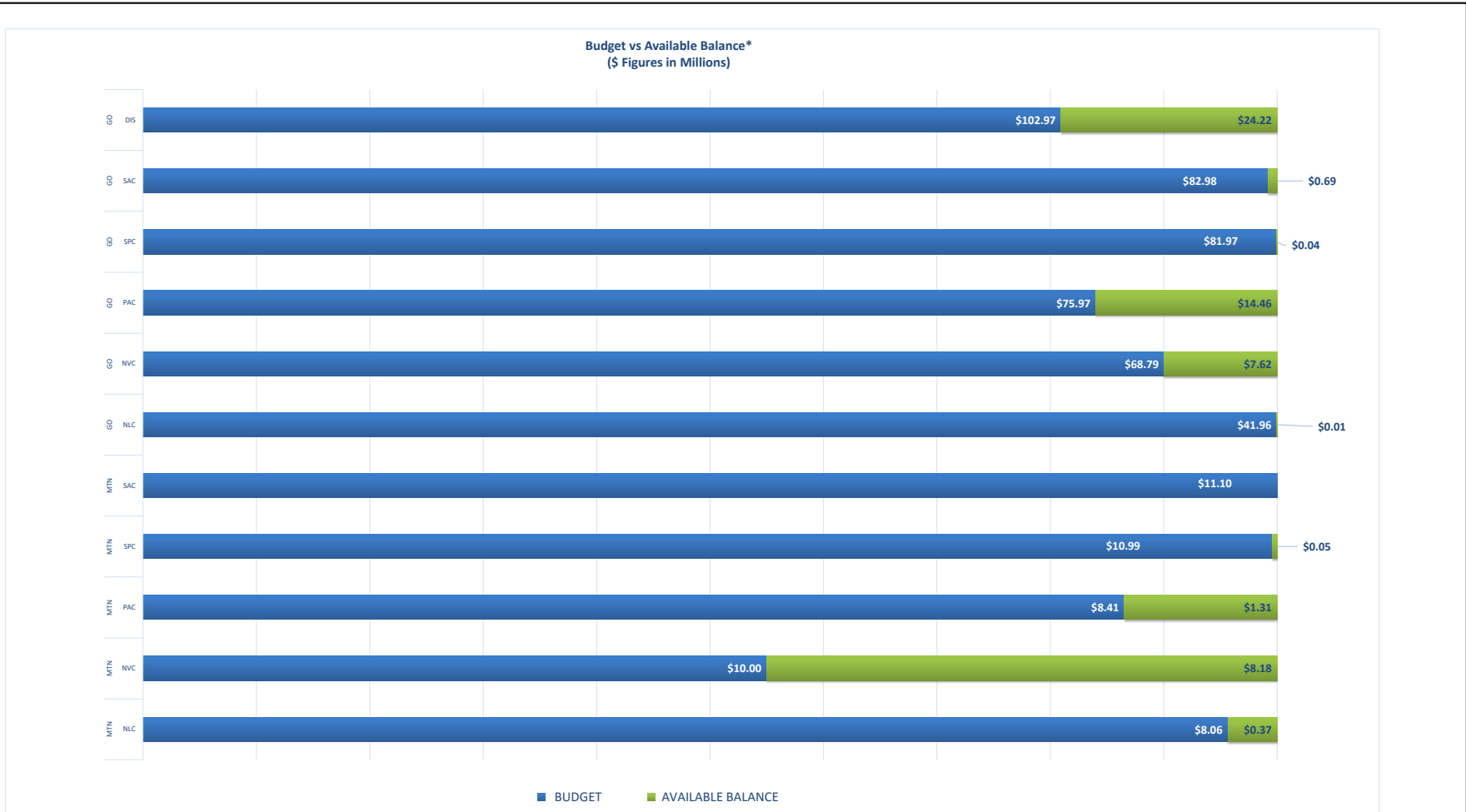

*Available balance reduced by actual amount expended as well as committed to spend.



ALAMO COLLEGES DISTRICT
2017 - CAPITAL IMPROVEMENT PROGRAM SUMMARY
As of March 31, 2024

FUNDING SOURCES	GO 2017 Tax Bonds	Limited Tax Bonds	MTN 2020 Maintenance Tax Bonds	GO 2021 Limited Tax Bonds	GO 2022 Tax Bonds	Limited Tax Bonds	TOTAL
General Obligation Bonds	\$ 173,000,000		\$ -	\$ 225,000,000	\$ 52,000,000		\$ 450,000,000
Maintenance Tax Note Bonds			\$ 50,000,000				\$ 50,000,000
TOTAL FUNDING SOURCES	\$ 173,000,000		\$ 50,000,000	\$ 225,000,000	\$ 52,000,000		\$ 500,000,000

BY LOCATION	BUDGET	CURRENT YEAR TOTAL	PRIOR YEARS' TOTAL	TOTAL TO DATE ALL YEARS	COMMITMENTS	AVAILABLE BALANCE
DISTRICT & DISTRICT WIDE - 2017 G.O. BOND	\$ 102,967,546	\$ 1,384,689	\$ 73,694,438	\$ 75,079,127	\$ 3,668,728	\$ 24,219,691
SAN ANTONIO COLLEGE - 2017 G.O. BOND	\$ 82,982,629	\$ 766,033	\$ 81,223,125	\$ 81,989,158	\$ 305,209	\$ 688,262
ST. PHILIP'S COLLEGE & SWC - 2017 G.O. BOND	\$ 81,970,072	\$ 35,631	\$ 81,846,040	\$ 81,881,671	\$ 45,712	\$ 42,689
PALO ALTO COLLEGE - 2017 G.O. BOND	\$ 75,966,160	\$ 1,203,142	\$ 56,912,658	\$ 58,115,801	\$ 3,395,086	\$ 14,455,273
NORTHWEST VISTA COLLEGE - 2017 G.O. BOND	\$ 68,790,182	\$ 410,969	\$ 57,909,060	\$ 58,320,029	\$ 2,850,499	\$ 7,619,654
NORTHEAST LAKEVIEW COLLEGE - 2017 G.O. BOND	\$ 41,958,546	\$ 101,159	\$ 41,495,850	\$ 41,597,009	\$ 347,882	\$ 13,655
General Obligation Bond Totals	\$ 454,635,135	\$ 3,901,623	\$ 393,081,171	\$ 396,982,794	\$ 10,613,117	\$ 47,039,225
SAN ANTONIO COLLEGE - 2020 MTN BOND	\$ 11,100,000	\$ -	\$ 11,100,000	\$ 11,100,000	\$ -	\$ -
ST. PHILIP'S COLLEGE & SWC - 2020 MTN BOND	\$ 10,991,512	\$ -	\$ 10,928,844	\$ 10,928,844	\$ 14,923	\$ 47,745
PALO ALTO COLLEGE - 2020 MTN BOND	\$ 8,406,930	\$ (2,242)	\$ 5,869,933	\$ 5,867,691	\$ 1,231,160	\$ 1,308,079
NORTHWEST VISTA COLLEGE - 2020 MTN BOND	\$ 10,000,000	\$ -	\$ 1,818,853	\$ 1,818,853	\$ -	\$ 8,181,147
NORTHEAST LAKEVIEW COLLEGE - 2020 MTN BOND	\$ 8,062,595	\$ 53,838	\$ 7,599,373	\$ 7,653,211	\$ 42,565	\$ 366,818
MTN Bond Totals	\$ 48,561,037	\$ 51,596	\$ 37,317,003	\$ 37,368,599	\$ 1,288,648	\$ 9,903,789
TOTAL FOR ALL 2017 CIP BONDS	\$ 503,196,172	\$ 3,953,219	\$ 430,398,174	\$ 434,351,393	\$ 11,901,765	\$ 56,943,014

2017 - CAPITAL IMPROVEMENT PROGRAM EXPENDITURES BY PROJECT

As of March 31, 2024

General Obligation Bonds							
PROJECT TITLE	Adjusted Budget	Current Month Expenses	Current Yr Expenses	Prior Yrs Expenses	Total to Date All Yrs Expenses	Commitments	Available Balance
DIS-WETC GO17 - T1	23,990,154	-	8,907	23,689,715	23,698,621	84,000	207,533
DIS-SETC GO17 - T1	22,977,392	5,000	107,887	19,715,795	19,823,681	637,050	2,516,660
DIS-N. 281 Property purch - GO17 - T1	5,000,000	-	-	5,000,000	5,000,000	-	-
DIS I-10 NW Ed and Train Ctr. - GO17 - T2	23,000,000	26,000	163,249	2,624,636	2,787,886	548,778	19,663,336
SWC- Redund Police Dpatch @ SWC - GO17 - T1	2,955,408	-	-	2,955,408	2,955,408	-	0
DIS MOKA Prog. MGT. - GO17	44,592	-	-	7,254	7,254	37,338	-
TOTAL FOR DISTRICT	\$ 77,967,546	\$ 31,000	\$ 280,043	\$ 53,992,807	\$ 54,272,850	\$ 1,307,166	\$ 22,387,530
DIS Instructional Tech GO17 - T1	1,500,000	-	-	1,077,961	1,077,961	-	422,039
DIS Infrastructural & ACOL GO17 T1	12,448,690	614,961	631,249	9,263,441	9,894,690	2,014,210	539,790
DIS Comm. & Collaboration Tools GO17 T1	4,100,000	-	-	3,997,214	3,997,214	-	102,786
Reporting and Analysis - T3	1,293,220	114,000	473,397	199,500	672,897	171,000	449,323
DIS Mobile Tech & Security GO17 - T3	5,658,090	-	-	5,163,515	5,163,515	176,352	318,223
TOTAL FOR DISTRICT WIDE INFO. TECH.	\$ 25,000,000	\$ 728,961	\$ 1,104,646	\$ 19,701,631	\$ 20,806,277	\$ 2,361,562	\$ 1,832,161
TOTAL FOR DISTRICT / DISTRICT WIDE	\$ 102,967,546	\$ 759,961	\$ 1,384,689	\$ 73,694,438	\$ 75,079,127	\$ 3,668,728	\$ 24,219,691
SAC-Parking Garage GO17 - T1	18,669,465	-	-	18,554,111	18,554,111	84,198	31,155
SAC-Childcare Bldg GO17 - T1	16,235,684	157,554	553,900	15,932,177	16,486,077	8,513	(258,906)
SAC Law Enforce/ 1st Responder - GO17 - T2	19,992,872	95,598	214,755	19,624,273	19,839,028	27,897	125,948
SAC Fletcher St Success Ren w/ Main Entry - GO17 - T2	9,798,431	-	(2,622)	9,691,698	9,689,076	55,275	54,080
SAC Physical Plant - GO17 - T3	2,477,282	-	-	2,471,654	2,471,654	5,627	1
SAC Chance Academic Ren - GO17 - T3	147,399	-	-	3,604	3,604	110,341	33,454
SAC MFA Ren - GO17 - T3	47,808	-	-	47,808	47,808	-	-
SAC NEW SCIENCE BLDG - GO17	15,613,689	-	-	14,897,801	14,897,801	13,358	702,530
TOTAL FOR SAC	\$ 82,982,629	\$ 253,152	\$ 766,033	\$ 81,223,125	\$ 81,989,158	\$ 305,209	\$ 688,262
SPC Culinary Arts Center Exc GO17 -T1	29,999,974	-	-	29,997,330	29,997,330	2,231	413
SPC Norris Tech Renovation GO17 - T2	14,882,376	-	-	14,851,838	14,851,838	11,363	19,174
SPC Bowden Renovation GO17 - T3	13,734,575	-	-	13,690,446	13,690,446	27,494	16,635
TOTAL FOR SPC	\$ 58,616,924	\$ -	\$ -	\$ 58,539,614	\$ 58,539,614	\$ 41,089	\$ 36,223
SPC Welding and Auto Body Fac -GO17 -T2	23,353,148	-	35,631	23,306,427	23,342,058	4,623	6,467
TOTAL FOR SWC	\$ 23,353,148	\$ -	\$ 35,631	\$ 23,306,427	\$ 23,342,058	\$ 4,623	\$ 6,467
TOTAL FOR SPC / SWC	\$ 81,970,072	\$ -	\$ 35,631	\$ 81,846,040	\$ 81,881,671	\$ 45,712	\$ 42,690

ALAMO COLLEGES DISTRICT
2017 - CAPITAL IMPROVEMENT PROGRAM EXPENDITURES BY PROJECT
As of March 31, 2024

General Obligation Bonds							
PROJECT TITLE	Adjusted Budget	Current Month Expenses	Current Yr Expenses	Prior Yrs Expenses	Total to Date All Yrs Expenses	Commitments	Available Balance
PAC Manufacturing Bldg GO17 - T1	48,477,433	21,202	802,293	46,752,183	47,554,476	489,051	433,907
PAC Real Estate Purchase (under district funding) GO17 - T1	6,000,000	-	-	5,118,242	5,118,242	-	881,758
PAC Student Engagement & Welcome Ctr GO17 - T2	117,663	-	-	-	-	72,280	45,384
PAC Natatorium and Gym Ren GO17 - T2	17,784,258	281,258	422,817	1,442,500	1,865,318	2,824,716	13,094,225
PAC Physical Plant GO17 - T3	3,586,806	-	(21,968)	3,599,733	3,577,765	9,040	0
TOTAL FOR PAC	\$ 75,966,160	\$ 302,459	\$ 1,203,142	\$ 56,912,658	\$ 58,115,801	\$ 3,395,086	\$ 14,455,273
NVC Parking Garage GO17 - T1	9,756,145	-	-	9,472,467	9,472,467	229,392	54,286
NVC Welcome Ctr. GO17 - T1	17,873,204	-	12,218	15,698,925	15,711,143	59,277	2,102,784
NVC Cultural Prog Ctr Excellen GO17 - T2	4,671,863	177,070	302,957	1,610,570	1,913,527	2,080,666	677,670
NVC STEM GO17 - T3	33,690,182	54,368	95,794	28,408,668	28,504,462	400,806	4,784,914
NVC Physical Plant GO17 - T3	2,798,788	-	-	2,718,430	2,718,430	80,358	(0)
TOTAL FOR NVC	\$ 68,790,182	\$ 231,438	\$ 410,969	\$ 57,909,060	\$ 58,320,029	\$ 2,850,499	\$ 7,619,654
NLC Tech Ctr Excellence/Science Building GO17 - T2	41,958,546	1,655	101,159	41,495,850	41,597,009	347,882	13,655
TOTAL FOR NLC	\$ 41,958,546	\$ 1,655	\$ 101,159	\$ 41,495,850	\$ 41,597,009	\$ 347,882	\$ 13,655
TOTAL 2017 G.O. BONDS	\$ 454,635,135	\$ 1,548,665	\$ 3,901,623	\$ 393,081,171	\$ 396,982,794	\$ 10,613,117	\$ 47,039,226

ALAMO COLLEGES DISTRICT
2017 - CAPITAL IMPROVEMENT PROGRAM EXPENDITURES BY PROJECT
As of March 31, 2024

Maintenance Tax Notes							
PROJECT TITLE	Adjusted Budget	Current Month Expenses	Current Yr Expenses	Prior Yrs Expenses	Total to Date All Yrs Expenses	Commitments	Available Balance
SAC FLETCH ST SCSS MTN20	11,100,000	-	-	11,100,000	11,100,000	-	-
TOTAL FOR SAC	11,100,000	-	-	11,100,000	11,100,000	-	-
SPC THCA Culinary-MTN20	2,173,235	-	-	2,126,296	2,126,296	9,210	37,729
SPC NORRIS TECH MTN20	8,453,992	-	-	8,448,279	8,448,279	5,713	0
SPC UNALLOCATED MTN20	10,000	-	-	-	-	-	10,000
TOTAL FOR SPC / SWC	10,991,512	-	-	10,928,844	10,928,844	14,923	47,745
PAC NATA & GYM IMP - MTN20	8,406,930	-	(2,242)	5,869,933	5,867,691	1,231,160	1,308,079
TOTAL FOR PAC	8,406,930	-	(2,242)	5,869,933	5,867,691	1,231,160	1,308,079
NVC CUL PRGMS CYP REN - MTN20	8,181,147	-	-	-	-	-	8,181,147
NVC WELCOME CTR - MTN20	1,818,853	-	-	1,818,853	1,818,853	-	0
TOTAL FOR NVC	10,000,000	-	-	1,818,853	1,818,853	-	8,181,147
NLC SCI/TECH CTR of EXEL - MTN20	5,643,897	-	53,838	5,344,507	5,398,345	36,664	208,888
NLC UNALLOCATED - MTN20	458	-	-	-	-	-	458
NLC ACA BLDG I ELEV - MTN20	1,274,314	-	-	1,260,941	1,260,941	5,902	7,472
NLC NLIB Elev & L Ren - MTN20	143,926	-	-	143,926	143,926	-	0
NLC STU COM MOIST BAR - MTN20	1,000,000	-	-	850,000	850,000	-	150,000
TOTAL FOR NLC	8,062,595	-	53,838	7,599,373	7,653,211	42,565	366,818
TOTAL 2020 MTN BONDS	\$ 48,561,037	\$ -	\$ 51,596	\$ 37,317,003	\$ 37,368,599	\$ 1,288,648	\$ 9,903,789
TOTAL 2017 CIP G.O. & MTN BONDS	\$ 503,196,172	\$ 1,548,665	\$ 3,953,219	\$ 430,398,174	\$ 434,351,393	\$ 11,901,765	\$ 56,943,015



ALAMO COLLEGES DISTRICT CAPITAL IMPROVEMENTS PROGRAM (CIP) EXECUTIVE SUMMARY

CIP Bond Construction *Projected* Upcoming CIP Project – for Board Approval

Estimated Upcoming GMP Board Pending Approval	May	Jul	Aug	Sept
NVC Cypress Cultural Center of Excellence Renovation (Vaughn/ Overland)		X		
PAC Multigenerational Center (Natatorium/Gym) (Joeris / RVK)				X
Northwest Education and Training Center (NWETC) (Byrne / Overland)	X			
TOTAL	1	1	-	1

CIP Bond Construction Projects by The Numbers

Project Status	SPC	SAC	NVC	PAC	NLC	ETCs	Total
Projects Completed	5	6	4	2	1	2	20
Projects in Construction							-
Projects with Approved GMP						1	1
Projects with Upcoming GMP Approval			1	1			2
Projects in Various Design Phases		1					1
TOTAL							24

CIP Bond Budget – As of May 2024

CIP - Available v. Expended (encumbered), G.O.

CIP General Obligation Bond - Available Budget

CIP G.O. & MTN Bond - Overall Available Budget

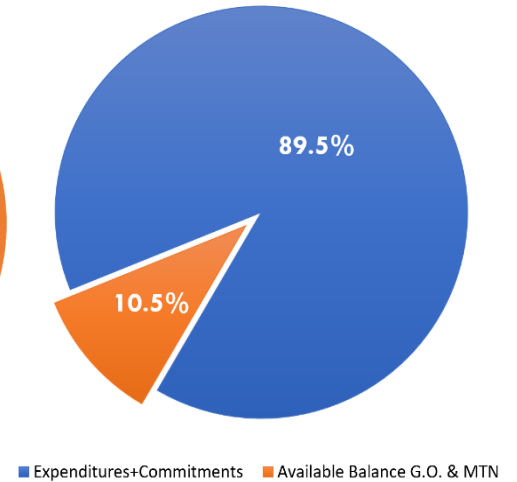
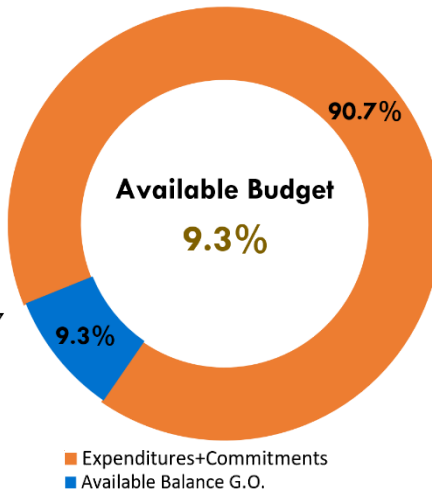
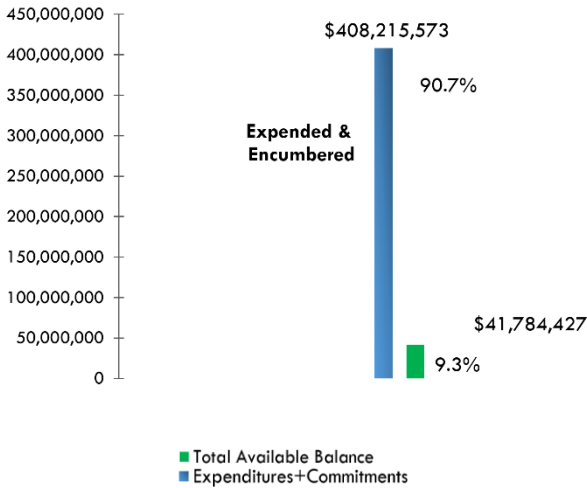

Issued - By Tranche		%	CIP General Obligation Bond - Available Budget	%	Overall CIP GO & MTN - Available Budget	%		
1st Tranche (GO17)	\$ 173,000,000	38.4%						
2nd Tranche (GO21)	\$ 225,000,000	50.0%						
3rd Tranche (GO22)	\$ 52,000,000	11.6%						
Total GO Bonds	\$ 450,000,000	100.0%	CIP GO Budget	\$ 450,000,000	100.0%	CIP GO+MTN Budget	\$ 499,161,314	100.0%
Expenditures+Commitments	\$ 408,215,573	90.7%	Expenditures+Commitments	408,215,573	90.7%	Expenditures+Commitments	446,880,796	89.5%
Total Available Balance	\$ 41,784,427	9.3%	Available Balance G.O.	\$ 41,784,427	9.3%	Available Balance G.O. & MTN	\$ 52,280,518	10.5%

Total General Obligation & MTN funding	Total expenditures on all CIP projects to date	Remaining balance of funding
\$499,161,314	\$435,247,429	\$52,280,518

**Preliminary Bond Budget Numbers as of April 30, 2024, subject to change and unaudited*



CIP Bond SMWVBE Reporting (as reported in April 2024)

San Antonio College

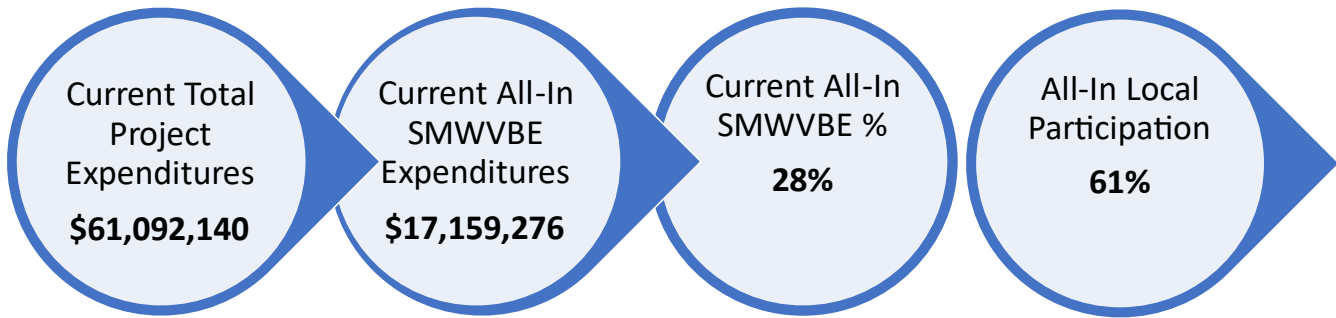

SAC All-In SMWVBE Breakdown

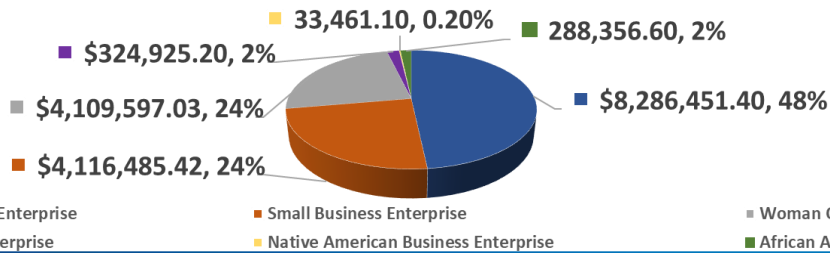



Northwest Vista College

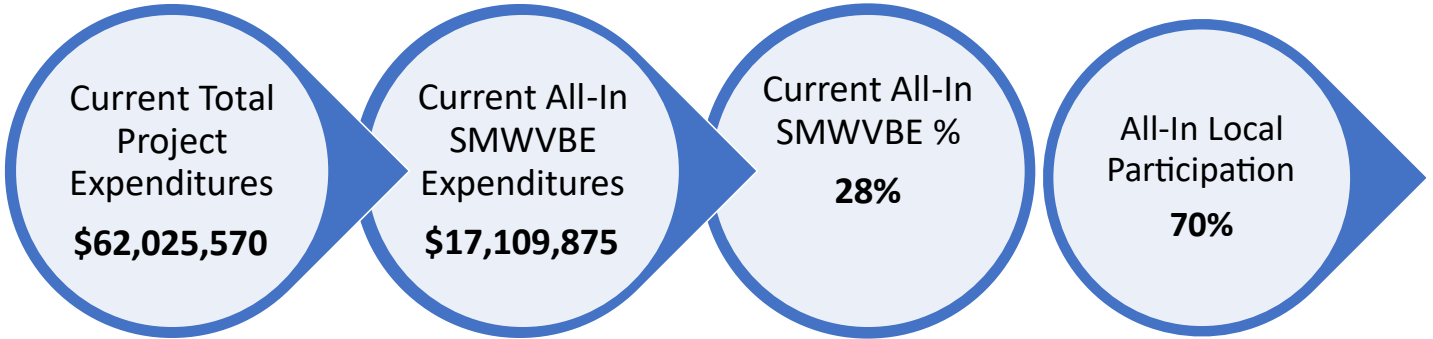

NVC All-In SMWVBE Breakdown

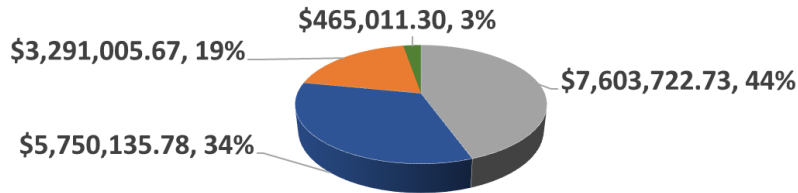

■ Woman Owned Business Enterprise
 ■ Hispanic American Business Enterprise
 ■ Small Business Enterprise
 ■ African American Business Enterprise



St. Philip's College

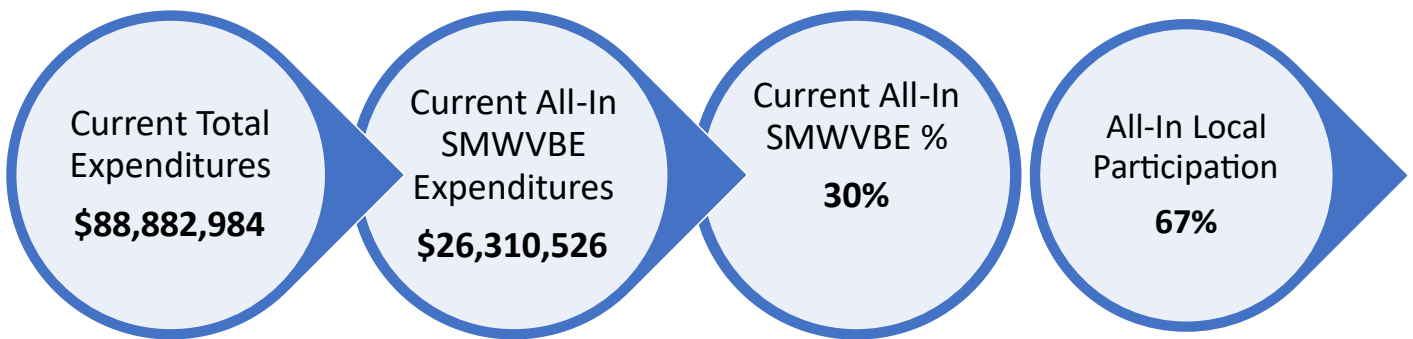

SPC All-In SMWVBE Breakdown

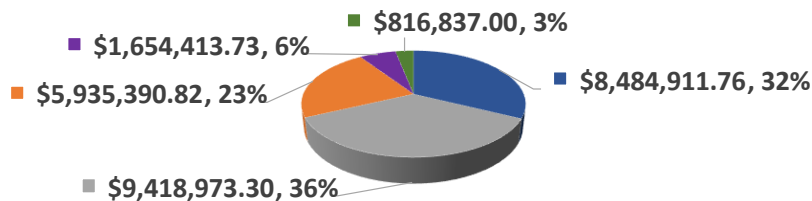

■ Hispanic American Business Enterprise
 ■ Woman Owned Business Enterprise
 ■ Small Business Enterprise
 ■ Asian American Business Enterprise
 ■ African American Business Enterprise





Northeast Lakeview College

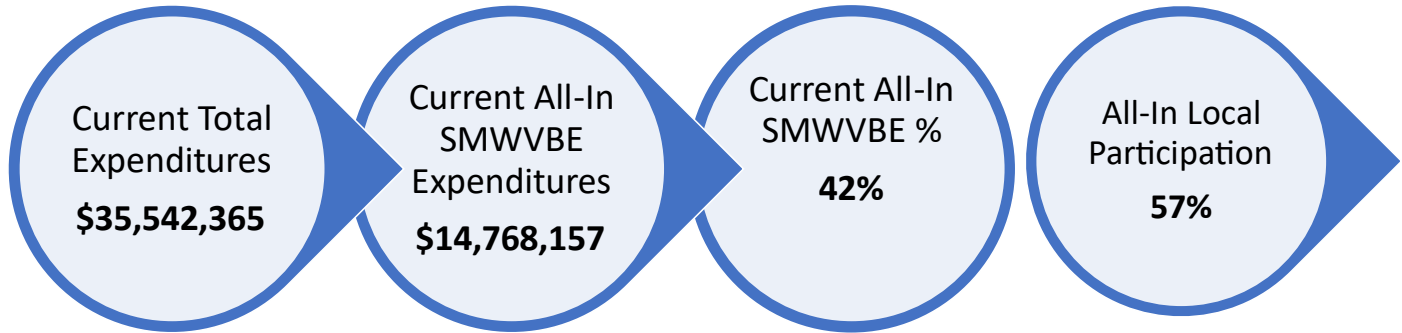

NLC All-In SMWVBE Breakdown

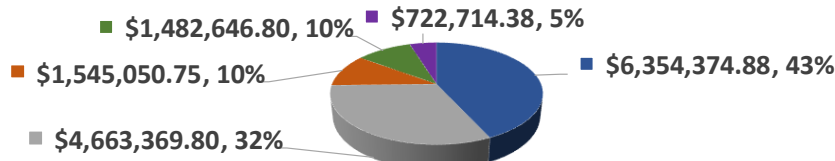

- Hispanic American Business Enterprise
- African American Business Enterprise
- Woman Owned Business Enterprise
- Asian American Business Enterprise
- Small Business Enterprise



Palo Alto College

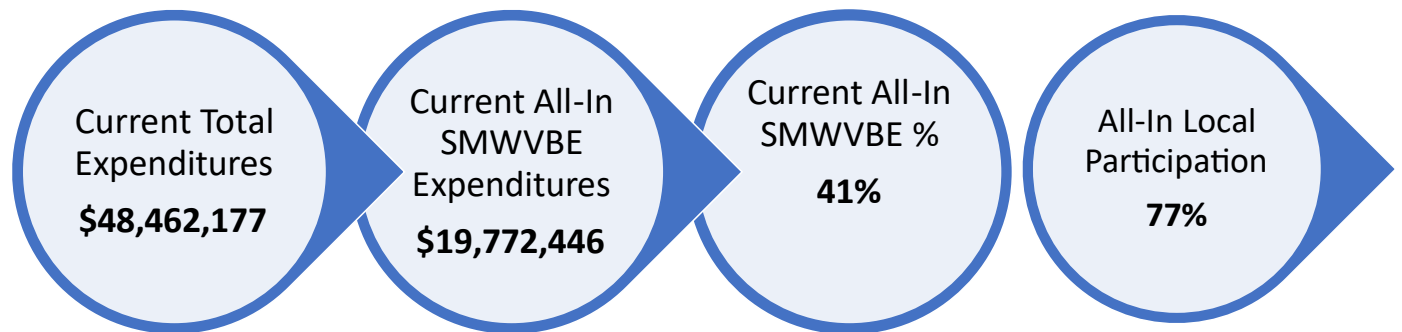

PAC All-In SMWVBE Breakdown

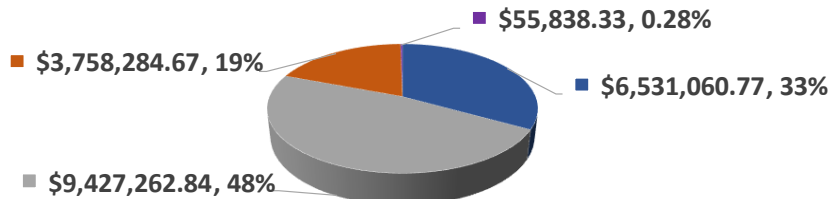

- Hispanic American Business Enterprise
- Woman Owned Business Enterprise
- Small Business Enterprise
- Asian American Business Enterprise





Education and Training Centers

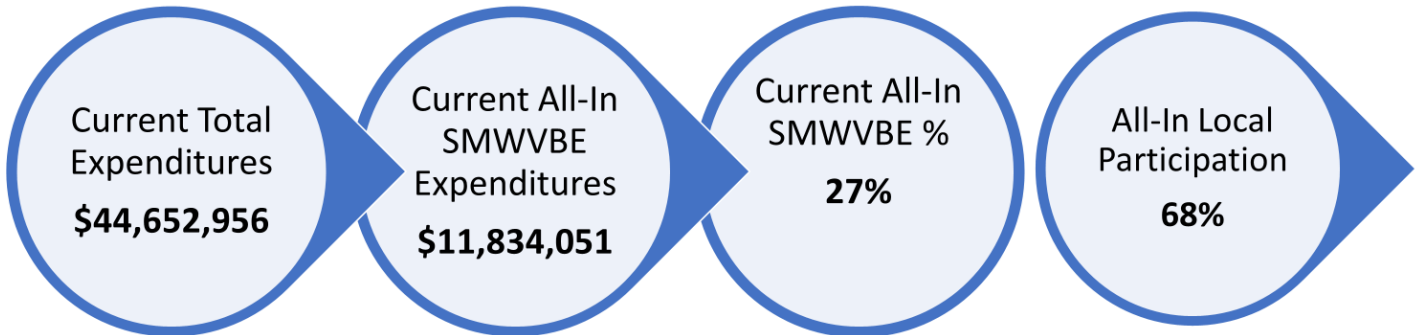

ETC All-In SMWVBE Breakdown

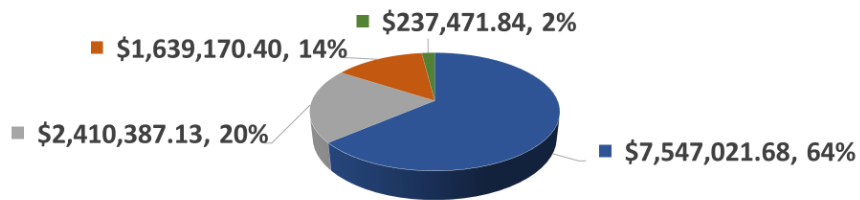

■ Hispanic American Business Enterprise
 ■ Woman Owned Business Enterprise
 ■ Small Business Enterprise
 ■ African American Business Enterprise



Discussion and Possible Action on Approval of Financial Reports

Presented to the Board acting as Committee of the Whole on May 14, 2024 and now presented to the ALAMO COLLEGES DISTRICT BOARD OF TRUSTEES for approval on May 21, 2024.

MINUTE ORDER

“The Alamo Colleges Board of Trustees hereby accepts the financial reports as presented.”

PURPOSE

The following financial reports are presented to the Board of Trustees for informational and approval purposes for March 31, 2024.

BACKGROUND

1. Financial Charts
2. Comparison of Year-to-Date Actual Revenues/Expenditures

IMPLICATIONS

Financial: N/A

Strategic Plan: Strategic Objective III Performance Excellence

Human Resources: N/A

ATTACHMENTS: Financial Reports

Lisa L. Mazure, MSA, CPA
Associate Vice Chancellor for Finance and
Fiscal Services

Dr. Thomas Cleary
Interim Vice Chancellor for Finance and
Administration

Dr. Mike Flores, Chancellor



**Alamo Colleges District
Current Operating Fund Cash Analysis**
(For Fiscal Years Ending August 2024, 2023 and 2022)
Through March 2024

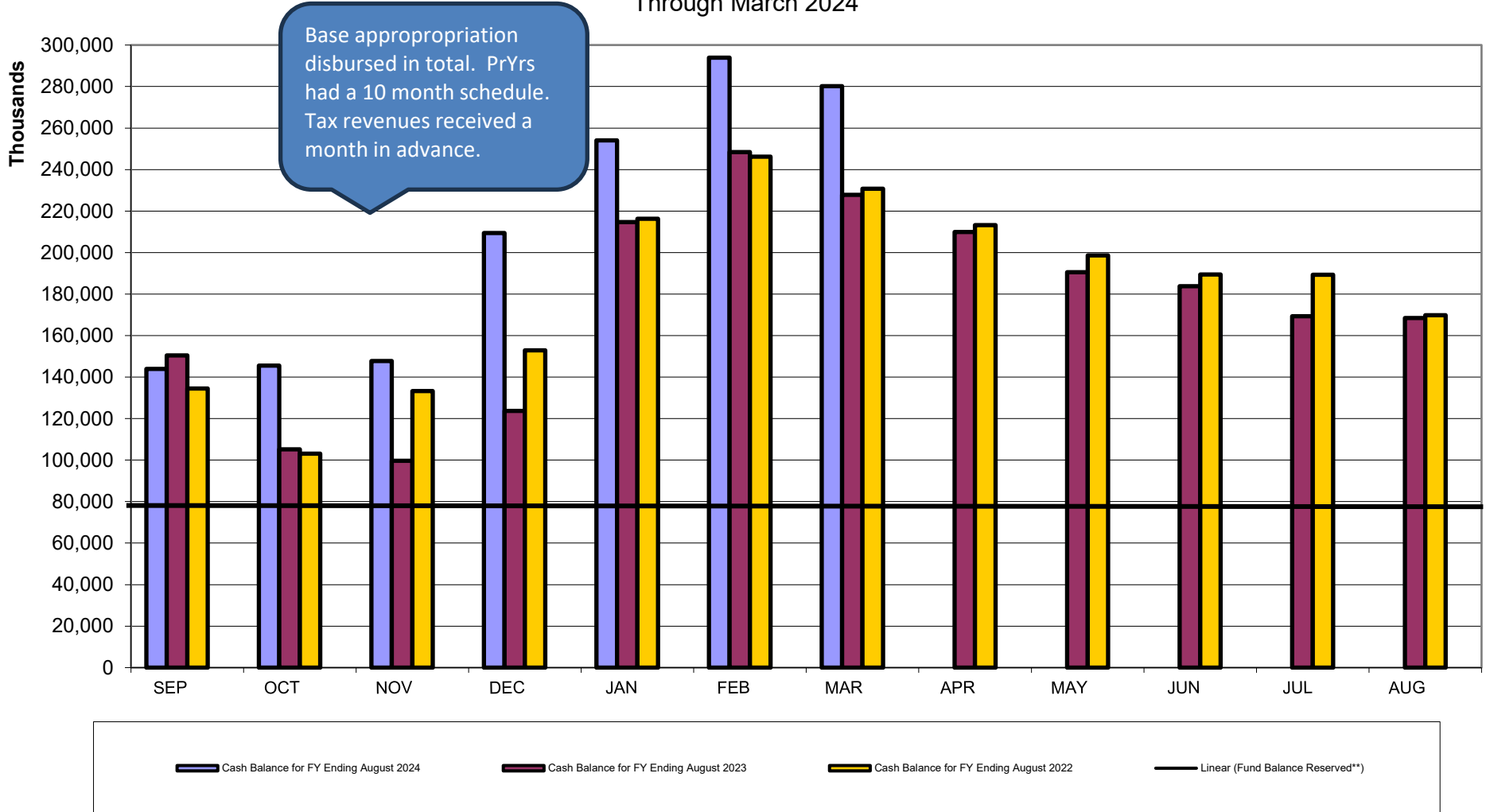

*Includes Cash and Investments.
 Chart excludes cash balances for capital construction and debt service.
 August includes Fall Tuition collections.

**Fund Balance Reserved excludes encumbrances and operating commitments.

Alamo Colleges District Unrestricted Operating Actual Revenues as % of Adjusted Budgeted Revenues Compared to Average of Two Prior Years Actual Revenues

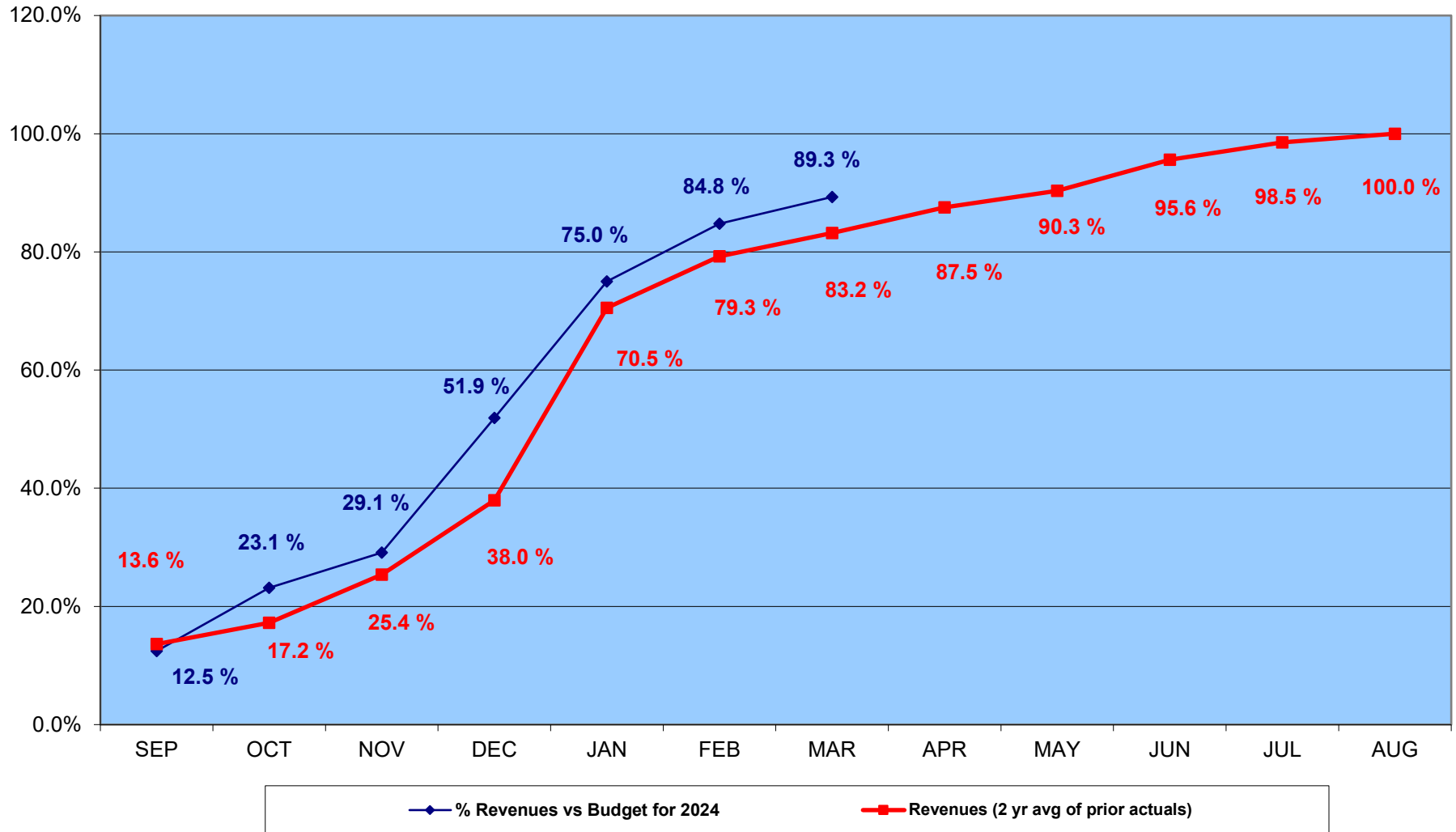

**Alamo Colleges District
 Unrestricted Operating Actual Expenses and Transfers as % of Adjusted Budgeted Expenses and Transfers
 Compared to Average of Two Prior Years Actual Expenses and Transfers**

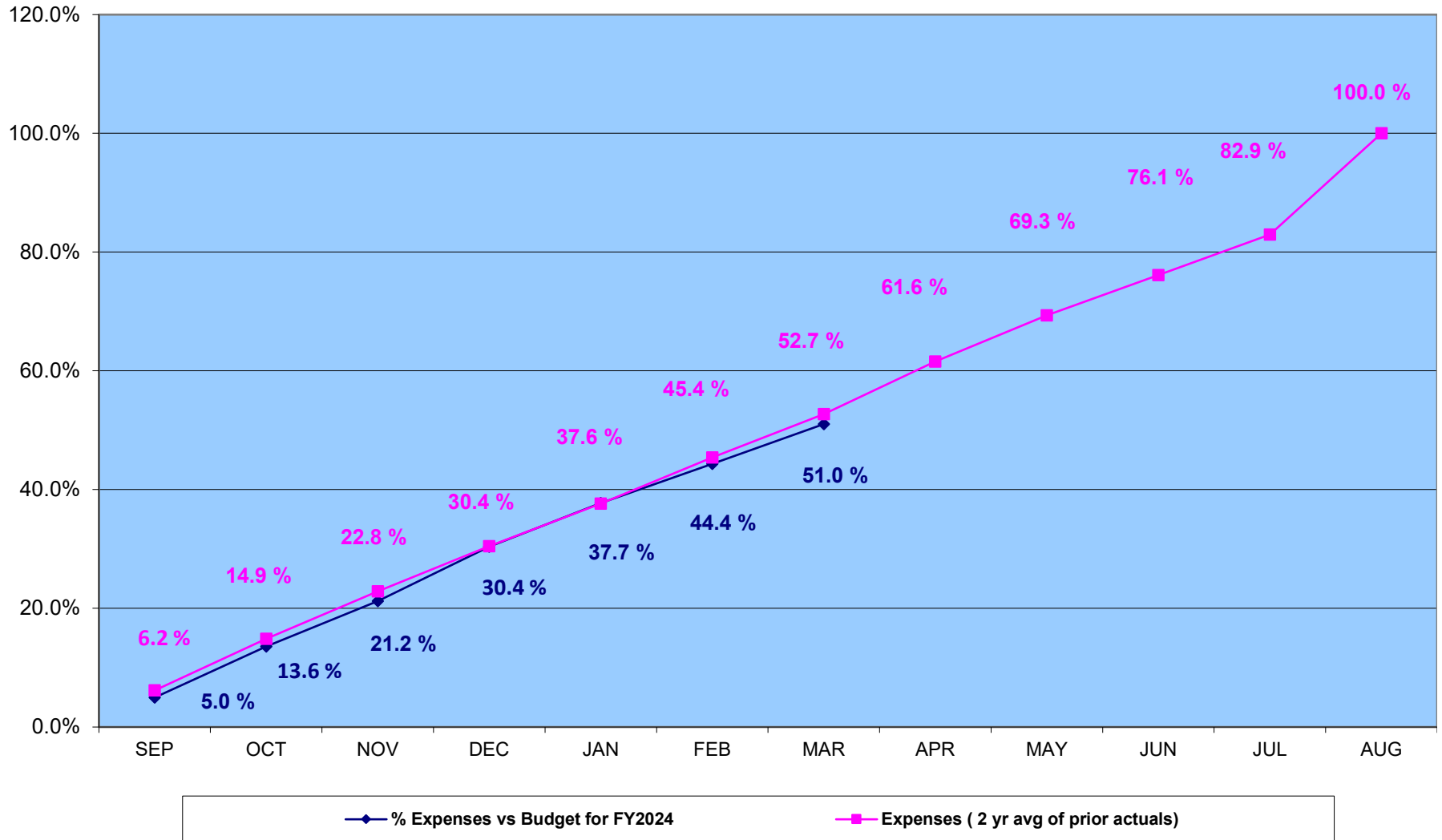

ALAMO COLLEGES DISTRICT
FY 2023 - 2024 ALL FUNDS ACTUALS VS BUDGET REPORT
MARCH 2024 YEAR-TO-DATE

	Adjusted Budget 2023 - 2024 (A) (as of March 2024)		YTD Actual 03/31/2024		% of Budget (7th month / 58.3 % of Year)			
	Unrestricted	Restricted	Unrestricted	Restricted	Unrestricted		Restricted	
					03/31/24	03/31/23	03/31/24	03/31/23
REVENUES								
Instruction and General	499,273,459	40,584,608	446,288,448	19,852,891	89.4%	83.2%	48.9%	37.4%
Public Service	644,939	-	351,520	-	54.5%	28.1%	-	-
Scholarships and Fellowships	-	86,666,367	-	70,710,613	-	-	81.6%	76.7%
Auxiliary Enterprises	3,574,852	-	2,734,003	-	76.5%	50.5%	-	-
Student Activity Fee	2,508,798	-	2,459,541	-	98.0%	94.6%	-	-
Subtotal Current Funds	506,002,048	127,250,975	451,833,512	90,563,504	89.3%	82.7%	71.2%	56.4%
Capital Outlay	-	10,322,153	-	2,194,420	-	-	21.3%	100.1%
Renewals & Replacements	-	-	-	-	-	-	-	-
Building	-	15,894,132	-	10,094,861	-	-	63.5%	92.4%
Furniture & Equipment	-	4,596,071	-	-	-	-	-	-
Debt Services	-	102,152,813	-	86,597,656	-	-	84.8%	90.1%
Subtotal Plant Funds	-	132,965,169	-	98,886,937	-	0.0%	74.4%	92.2%
TOTAL REVENUES	506,002,048	260,216,144	451,833,512	189,450,441	89.3%	82.7%	72.8%	83.3%
BEGINNING FUND BALANCES (B)								
Instruction and General	101,762,558	2,182,661	101,762,558	2,182,661	-	-	-	-
Public Service	-	-	-	-	-	-	-	-
Scholarships and Fellowships	-	8,952,401	-	8,952,401	-	-	-	-
Auxiliary Enterprises	3,200,000	-	3,200,000	-	-	-	-	-
Student Activity Fee	2,498,461	-	2,498,461	-	-	-	-	-
Subtotal Current Funds	107,461,019	11,135,062	107,461,019	11,135,062	-	-	-	-
Capital Outlay	-	75,430,171	-	75,430,171	-	-	-	-
Renewals & Replacements	-	-	-	-	-	-	-	-
Building	-	321,185,558	-	321,185,558	-	-	-	-
Furniture & Equipment	-	22,337,453	-	22,337,453	-	-	-	-
Debt Services	-	14,883,008	-	14,883,008	-	-	-	-
Subtotal Plant Funds	-	433,836,190	-	433,836,190	-	-	-	-
TOTAL BEGINNING FUND BALANCES	107,461,019	444,971,252	107,461,019	444,971,252	-	-	-	-
TOTAL AVAILABLE (Revenues + Beg. Fund Balance)								
Instruction and General	601,036,017	42,767,269	548,051,006	22,035,552	-	-	-	-
Public Service	644,939	-	351,520	-	-	-	-	-
Scholarships and Fellowships	-	95,618,768	-	79,663,014	-	-	-	-
Auxiliary Enterprises	6,774,852	-	5,934,003	-	-	-	-	-
Student Activity Fee	5,007,259	-	4,958,002	-	-	-	-	-
Subtotal Current Funds	613,463,067	138,386,037	559,294,531	101,698,566	-	-	-	-
Capital Outlay	-	85,752,324	-	77,624,591	-	-	-	-
Renewals & Replacements	-	-	-	-	-	-	-	-
Building	-	337,079,690	-	331,280,419	-	-	-	-
Furniture & Equipment	-	26,933,524	-	22,337,453	-	-	-	-
Debt Services	-	117,035,821	-	101,480,664	-	-	-	-
Subtotal Plant Funds	-	566,801,359	-	532,723,127	-	-	-	-
TOTAL AVAILABLE	613,463,067	705,187,396	559,294,531	634,421,693	-	-	-	-

(A) Includes budget amendments #1 and #2.

(B) Beginning fund balance are unaudited ending FY22-23 fund balances. The fund balances include Board mandated 15% operating reserve, grants, construction, scholarships, & gifts funds.

FY 2023 - 2024 ALL FUNDS ACTUALS VS BUDGET REPORT

MARCH 2024 YEAR-TO-DATE

	Adjusted Budget 2023 - 2024 (A) (as of March 2024)		YTD Actual 03/31/2024		% of Budget (7th month / 58.3 % of Year)			
	Unrestricted	Restricted	Unrestricted	Restricted	Unrestricted		Restricted	
					03/31/24	03/31/23	03/31/24	03/31/23
EXPENDITURES								
Instruction and Genera	493,779,413	40,584,608	243,118,346	21,614,980	49.2%	48.9%	53.3%	36.9%
Public Service	2,013,010	-	1,109,491	-	55.1%	221.5%		
Scholarships and Fellowships	-	92,838,865	-	77,006,896			82.9%	60.2%
Auxiliary Enterprises	1,883,503	-	426,317	-	22.6%	22.2%		
Student Activity Fee	2,865,214	-	1,610,937	-	56.2%	24.9%		
Subtotal Current Funds	500,541,140	133,423,473	246,265,091	98,621,876	49.2%	49.0%	73.9%	49.8%
Capital Outlay	-	44,112,278	-	18,480,793			41.9%	11.0%
Renewals & Replacements	-	-	-	-				
Building	-	170,130,764	-	20,598,837			12.1%	33.5%
Furniture & Equipment	-	5,983,812	-	429,314				
Debt Services	-	111,572,813	-	55,308,404			49.6%	71.9%
Subtotal Plant Funds	-	331,799,667	-	94,817,348			28.6%	30.3%
TOTAL EXPENDITURES	500,541,140	465,223,140	246,265,091	193,439,224	49.2%	49.0%	41.6%	36.4%
TRANSFERS (IN) OUT								
Instruction and General			20,478,103					
Public Service								
Scholarships and Fellowships	6,172,498	(6,172,498)		(3,026,273)				
Auxiliary Enterprises	-	-						
Student Activity Fee	-	-						
Subtotal Current Funds	6,172,498	(6,172,498)	20,478,103	(3,026,273)				
Capital Outlay	1,257,452	(1,257,452)		-				
Renewals & Replacements	-	-						
Building	51,000	(51,000)		(9,135,187)				
Furniture & Equipment	5,300,000	(5,300,000)						
Debt Services	9,420,000	(9,420,000)		(8,316,643)				
Subtotal Plant Funds	16,028,452	(16,028,452)	-	(17,451,830)				
NET TRANSFERS	22,200,950	(22,200,950)	20,478,103	(20,478,103)				
TOTAL EXPENSE & TRANSFERS	522,742,090	443,022,190	266,743,194	172,961,121	51.0%	49.3%	39.0%	35.7%
ENDING FUND BALANCES								
Instruction and General	107,256,604	2,182,661	284,454,558	420,572				
Public Service	(1,368,071)	-	(757,971)	-				
Scholarships and Fellowships	(6,172,498)	8,952,401	-	5,682,391				
Auxiliary Enterprises	4,891,349	-	5,507,686	-				
Student Activity Fee	2,142,045	-	3,347,064	-				
Subtotal Current Funds	106,749,429	11,135,062	292,551,337	6,102,963				
Capital Outlay	(1,257,452)	42,897,498	-	59,143,798				
Renewals & Replacements	-	-	-	-				
Building	(51,000)	166,999,926	-	319,816,769				
Furniture & Equipment	(5,300,000)	26,249,712	-	21,908,139				
Debt Services	(9,420,000)	14,883,009	-	54,488,903				
Subtotal Plant Funds	(16,028,452)	251,030,145	-	455,357,609				
TOTAL ENDING FUND BALANCES	90,720,977	262,165,207	292,551,337	461,460,572				
TOTAL EXP, TRF & BALANCES	613,463,067	705,187,396	559,294,531	634,421,693				

(A) Includes budget amendments #1 and #2.

ALAMO COLLEGES DISTRICT
FOR THE SEVEN MONTH PERIOD ENDED MARCH 31, 2024

(1) Revenue Variance:

For the seven month period ended March 31, 2024 operating revenue increased 24.9%, or \$90.1 million to \$451.8 million (first seven months 2023: \$361.7 million). The increase is attributed to tax revenues from expanding property valuations, resulting in an increase of \$29.7 million over last year. Base state appropriations being disbursed upfront in FY23, coupled with increased funding resulting from formula distribution changes, compared to a 10-month schedule in prior years, resulted in a \$37.9 million increase. Tuition and fee revenues also increased, delivering \$16.9 million additional funds over last year. Other income also increased \$5.6 million.

- a) Tax revenues for FY24 stand at \$238.0 million vs \$208.3 million in the prior year, an increase of \$29.7 million from the prior year. This represents 93.2% of the budgeted FY24 amount vs. 90.2% in FY23. The budget for tax revenues for FY24 and FY23 stand at \$255.4 million and \$230.9 million. The District continues to benefit from increasing taxable values in Bexar County. The projected ad valorem taxes increase as the taxable assessed value of properties across Bexar County providing a 10% increase in budgeted tax revenues, with no change to the property tax rate. This increase will continue to fund critical facilities maintenance and operations, expansion of workforce programs like nursing and high demand programs.
- b) Tuition & fees for FY24 increased 17.6%, or \$16.9 million, from FY23 amounts. FY24 revenues stand at \$112.8 million, or 96.6% of the budget, vs. FY23 revenues of \$95.9 million, or 93.2% of the budget. The regular tuition positive variance is attributed to an increase in headcounts and semester credit hours taken, in addition to tuition rate increases approved in FY24. Headcount enrollment for Spring 2024 increased 9.3% or 5,809 students to 68,432. Spring 2024 semester hours showed a similar increase of 7.9%, or 33,309, to 453,155 semester credit hours (As of 02/29/2024). Headcount enrollment for Fall 2023 increased 7.0% or 5,007 students to 71,463. Fall 2023 semester hours showed a much larger increase of 10.4%, or 51,856, to 500,839 semester credit hours (As of 10/30/2023).
- c) State appropriations increased 79.5% in FY24, or \$37.9 million, and stand at 73.3% of the budget for FY24 and 53.5% for FY23. As of this month the revenues are \$85.6 and \$47.7 million, respectively. State appropriations including state-paid benefits (group health & retirement) shows a significant increase over last year as reflected in budgeted amounts. Budgeted appropriations for FY24 are \$116.8 million vs. \$89.2 million for the prior year. And the distribution method is different too. Base state appropriations are being distributed upfront in FY24 vs a 10-month schedule in FY23 reflected in the year-to-date increase.

(2) Expense Variance:

- a) The total All Funds expense budget approved by the Board of Trustees for FY 2023-2024 is \$946.9 million, comprised of \$503.9 million in operating expense and \$443.0 million in restricted funds. The operating expense budget is developed using the Funding Model, explained in detail in the approved budget book. The President of each of the five colleges maintains local control of their operating funds and distributes their respective allocated budget to: (a) funded employee positions, and (b) departmental operational expense accounts, based on the strategic initiatives and priorities at that location. The driving force behind the FY24 operating budget is funding the strategic priorities of the Alamo Colleges District (ACD) for our students. ACD, the largest higher education institution in South Texas and the only community college system to win the Malcolm Baldrige National Quality Award, is working to fulfill Chancellor Dr. Mike Flores' moon shot vision of ending poverty in San Antonio through education. To make this bold vision a reality, the District and its five colleges - St. Philip's College, San Antonio College, Palo Alto College, Northwest Vista College and Northeast Lakeview College - are working to make access to a college education and successful completion of a degree or certificate accessible to all residents in its eight-county service area. ACD has implemented the following investment strategies based on several identified community needs to provide accessible college education and opportunities for achieving student success.
- b) Operating expenses for FY24 and FY23 for the same period stand at 51.0% and 47.5% of budget, respectively. actual expenses for FY24 and FY23 are \$266.7 million and \$223.6 million.

Discussion and Possible Action on Approval of Monthly Report on Cooperative Purchases in Excess of \$200,000

Presented to the Board Acting as Committee of the Whole on May 14, 2024 and now presented to Board for approval on May 21, 2024.

MINUTE ORDER

“The Alamo Colleges District Board of Trustees hereby approves the monthly Cooperative Purchase Report as presented.”

PURPOSE

The purpose of this Minute Order is to provide a monthly report of purchases exceeding \$200,000 and any fees charged by the various local, state, and national providers of Cooperative Purchasing (COOP) programs during the specified reporting period. Not all COOP programs charge fees, and some COOP's offer cash rebates paid directly to Alamo Colleges. The Purchasing and Contract Administration Department utilizes the COOP programs to gain greater access to goods and services, cost savings through leveraged buying, and reduced administration costs by issuing fewer competitive bids and proposals. The combined buying power of public institutions throughout the State of Texas and nationally translates into savings and provides an efficient, cost effective and legal means for providing goods and services to departments throughout the Alamo Colleges in an expedited fashion.

BACKGROUND

Vendor contracts awarded through approved federal, state or cooperative purchasing agreements are a statutorily approved alternative to competitively procured vendor contracts. Only the following such contract purchases require prior Board approval:

- a. Purchases valued at \$200,000 or more in any 12-month period that will result in additional gross square footage (permanent or otherwise) that will require cleaning and maintaining, and have at least two utilities present.
- b. Purchases valued at \$200,000 or more in any 12-month period that in the judgment of the Chancellor or Purchasing & Contract Administration would commit the College District or one of the colleges to an entirely new technology that would be pervasive for subsequent years.

For any cooperative purchasing contract valued at \$25,000 or more, Purchasing & Contract Administration shall document any contract-related fee, including any management fee. At least annually, Purchasing & Contract Administration shall present a written report regarding any contract-related fees, including any management fees, to the Board of Trustees at a properly posted open meeting.

IMPLICATIONS

Financial: None

Strategic Plans: Goal I-Student Success; and Goal III-Performance Excellence

Employee Services: None

Attachments: Cooperative Contract Purchases over \$200,000

Lisa L. Mazure, MSA, CPA, CGFM
Associate Vice Chancellor, Finance & Fiscal Svc

Dr. Thomas Cleary
Interim Vice Chancellor for Finance & Administration

Dr. Mike Flores
Chancellor



**COOPERATIVE CONTRACT PURCHASES OVER
\$200,000**

Location	Type of Funding	Description	Purpose/Why	COOP Admin	Total Cost	Vendor/ Co-Op
St. Philip's College/ Theater and Fine Arts	SPC- ED Cross - Title III Act3	Purchase of 604 Auditorium Seating for the St. Philip's College Watson Fine Arts Building	Provide new seating for students, faculty, staff and community use	\$0.00	\$298,882.49	Series USA LLC Omnia Region ESC- TX 07-117
San Antonio College/ Facilities Office	SAC Operating	Recover and Restoration Services under Loftin in crawlspace – flood	Disaster recovery service	\$0.00	\$243,812.47	Cotton Commercial BuyBoard 675-22
ACCESS / Office of Information Technologies	ACCESS Operating	Purchase of (161) HP notebooks, (177) HP conferencing monitors, (177) keyboard and mouse combo and (16) HP mobile workstations	Provide latest technology to support staff at ACCESS	\$0.00	\$313,861.50	Intech Southwest DIR-TSO-4159
San Antonio College, ACCESS, Northwest Vista College, St. Philip's College and Southwest Campus	SAC Operating, DSO Operating, NVC Operating, and SPC Operating	Purchase of Annual Elevator Maintenance	Provide Annual Preventative Maintenance on Elevators	\$0.00	\$334,311.02	Kone Incorporated Omnia Partners 2516
ACCESS / Facilities	Grant – DWD – Preventative Maintenance – UCF	Purchase of one-time Preventive Maintenance Technology replacement	Provide latest technology to support staff at ACCESS	\$0.00	\$321,591.34	Convergent Technologies LLC Omnia Partners R220702
St. Philip's College / Office of Information & Communication Technologies	Grant – Future ACT funds	Purchase of audio-visual equipment and programming for eight event center rooms at St. Philip's College – Southwest Campus	To provide updated technology and infrastructure to serve the primary academic mission of the campus (i.e. student services and the teaching and learning of students, face-to-face and virtually).	\$0.00	\$202,904.00	Howard Technology Solutions BuyBoard 661-22
ACCESS / Office of Information Technologies	DIS Infrastructure & ACOL G017	Purchase of OmniAccess Stellar networking hardware	To provide updated technology and infrastructure to serve the primary academic mission of the campus (i.e. student services and the teaching and learning of students, fact-to-face and virtually).	\$0.00	\$206,661.00	Intech Southwest Solutions LLC TIPS 230105
ACCESS / Office of Information Technologies	ACCESS Operating	Purchase of the Cornerstone Learning Suite, Performance Suite, and Recruiting Suite	To expand implementation and refinement of continuous improvement activities, including but not limited to the three elements of the AlamoWAY: Student Success, Principle-Centered Leadership, and Performance Excellence	\$0.00	\$252,175.51	Cornerstone OnDemand DIR-CPO-5036
San Antonio College / Office Technology Services	SAC Operating	Purchase of 209 Optiplex All-in-one (plus 7410) Desktop Computers	To provide updated technology and infrastructure to serve the primary academic mission of the campus (i.e. student services and the teaching and learning of students, face-to-face and virtually).	\$0.00	\$344,641.00	Dell Computer Corp DIR-TSO-3763
Northwest Vista College / Office of Information & Communications Technologies	NVC Operating	Purchase of 500 Dell Latitude 3440 Laptops and Charging Cart	To provide updated technology and infrastructure to serve the primary academic mission of the campus (i.e. student services and the teaching and learning of students, face-to-face and virtually).	\$0.00	\$932,310.00	Dell Marketing LP DIR-TSO-3763
DIR-TSO-3763	NVC Operating	Purchase of 500 Dell Latitude 3440 Laptops	To provide updated technology and infrastructure to serve the primary academic mission of the campus (i.e. student services and the teaching and learning of students, face-to-face and virtually).	\$0.00	\$434,500	Dell Marketing LP DIR-TSO-3763

ACCESS / Facilities	DIS MTN23 Projects	Installation of Genetic security network hardware (cameras, intelligent control boards, and reader locks), software, licensing, and training.	For full scale security network transition from Vanderbilt to Genetec execution for the security of students, staff, faculty and visitors.	\$0.00	\$204,055.04	Convergent Technologies LLC Omnia Partners R220702
ACCESS / Facilities	DIS MTN23 Projects	Installation of Genetic security network hardware (cameras, intelligent control boards, and reader locks), software, licensing, and training.	For full scale security network transition from Vanderbilt to Genetec execution for the security of students, staff, faculty and visitors.	\$0.00	\$1,676,865.61	Convergent Technologies LLC Omnia Partners R220702

Discussion and Possible Action for the Purchase of Banking Services

Presented to the Board Acting as Committee of the Whole on May 14, 2024 and now presented for approval on May 21, 2024.

MINUTE ORDER

"The Board of Trustees hereby awards a contract to JPMorgan Chase Bank, N.A., providing for the purchase of Banking Services in the estimated annual amount of \$61,680, as requested by the Interim Vice Chancellor for Finance and Administration."

PURPOSE

This contract action provides for the purchase of Banking Services for the Finance and Fiscal Services Treasury Office. The scope of work includes providing the materials, labor, and systems for services including: online banking, depository, disbursing, Automated Clearing House (ACH) and wire, and collateralization of deposits on an as needed basis. It is anticipated that purchase of these services will provide for optimization of Alamo Colleges District's banking costs and service needs to assist in improving operational efficiency, assisting in meeting its cash management goals, and all transaction activity of its accounts.

BACKGROUND

In March 2020, the Board of Trustees awarded a contract to Bank of America, N.A. providing for the purchase of Banking Services with an initial term ending August 2022, and options for renewal. The contract was renewed for FY23 and FY24, with the latest renewal expiring on August 31, 2024.

On November 30, 2023, a notice soliciting request for proposals was advertised in the San Antonio Express News and La Prensa twice over a 54-day period. Additionally, Purchasing and Contract Administration sent notices to over 58 potential Offerors. Five proposals were received and evaluated by representatives from the Finance and Fiscal Services Treasury and General Accounting departments, considering the RFP specifications and requirements. As a result of this effort, the proposal submitted by JPMorgan Chase Bank, N.A. is recommended for award on a best value basis. The contract will begin upon award and terminate August 31, 2027, and have two biennial options for renewal upon mutual consent of JPMorgan Chase Bank, N.A. and Alamo Colleges District.

IMPLICATIONS

Financial: Estimated \$61,680 annually

Funding Source: Institutional Funding

Strategic Objective: Goal III Performance Excellence

Human Resources: None

ATTACHMENTS

Proposal Tabulation and Evaluation Criteria

Lisa L. Mazure, MSA, CPA Date
Associate Vice Chancellor for Finance
and Fiscal Services

Dr. Thomas Cleary Date
Interim Vice Chancellor for Finance and
Administration

Dr. Mike Flores Date
Chancellor

Discussion and Possible Action on Amending the Guaranteed Maximum Price (GMP) for Alamo Colleges District San Antonio College Empowerment Center (CSP 18C-005)

Consent Agenda Approval item, presented to the Board Acting as Committee of the Whole on May 14, 2024 and now presented to the Board for approval on May 21, 2024.

MINUTE ORDER

"The Board of Trustees hereby approves the Guaranteed Maximum Price increase of \$422,499 for the Construction Manager-at-Risk J.T. Vaughn Construction, LLC for a new total \$9,556,083 for the purchase of construction services for the San Antonio College Empowerment Center subject to subsequent execution of GMP acceptable to District Counsel as requested by the Associate Vice Chancellor for Facilities Operations and Construction Management."

PURPOSE

To amend the GMP for one change order to incorporate design alternates selected by SAC leadership (funds not available at time of award).

BACKGROUND

On December 13, 2023, the Board of Trustees approved the GMP in the amount of \$9,164,384 with construction manager-at-risk J.T. Vaughn Construction, LLC. for the work package for the San Antonio College Empowerment Center funded primarily by State Appropriations from the 86th Legislative Session in FY20 and FY21 Biennium.

IMPLICATIONS

Financial: GMP Work Package increased to \$9,556,083 out of Total Project Budget increased to \$10,646,099. Funded by \$10,233,600 in State Appropriations and \$422,499 in Institutional funds.

Objective: I. Student Success and III. Performance Excellence

Employee Services: None

ATTACHMENTS: Presentation

Lisa L. Mazure, MSA, CPA.
Assoc Vice Chancellor for Finance and
Fiscal Services

Gregory L. McClure
Assoc. Vice Chancellor for Facilities Operations
and Construction Management

Dr. Thomas S. Cleary
Interim Vice Chancellor for Finance & Admin.

Dr. Mike Flores
Chancellor

