



COUPLAND ISD

620 S COMMERCE ST

COUPLAND, TX 78615

512-856-2422

REGULAR MEETING AGENDA

Date: Thursday, May 8, 2025
Time: Immediately following Public Hearing
Location: Coupland School Library
620 S. Commerce Street
Coupland, TX 78615

AGENDA

1. Call the meeting to order and establish a quorum.
2. Pledge of Allegiance
3. Recognitions
4. Principal's Report
5. Superintendent's Report
6. Public Comments
7. Construction Update:
Christine Walker- Claycomb and Associates (Architect)
Randy Boone - Weaver & Jacobs (CMAR)
8. MONTHLY ACTION ITEMS:
 - A. Consider and Approve the Board of Trustees Meeting Minutes for the Budget Workshop #1 held April 10, 2025 and the Regular Meeting also held April 10, 2025.
 - B. Approve Monthly Bills and Monthly Financial Reports
9. APPROVAL OF ADDITIONAL ACTION ITEMS AS NEEDED:
 - A. Consideration and possible action regarding the possible donation of right of way/land of the District's property described as follows: 1.355 acres (59,044 square feet) tract or parcel of land situated in the Joseph Jordan Survey, Abstract No. 357, Williamson County, Texas, and being a portion of a called 61.7162 acre tract of land described in the deed to Coupland Independent School District, recorded in instrument No. 2007071605, said official public records of Williamson County,

Texas. The donation of land is for public purposes for the construction of a road part of the County's 2023 Bond Program CR 460. The Board will further consider a resolution declaring the property is not needed for educational purposes and the District will receive a benefit from the donation.

- B. Consider and Approve a Master Service Agreement for Technology Support for August 2025 to July 2026
- C. Consider and Approve a Letter of Engagement with an Auditor to Conduct an Efficiency Audit
- D. Consider and Approve a Contracted Services Agreement_Special Education Director
- E. Consider and Approve a Contracted Services Agreement_Business Office and Human Resources
- F. Consider, Discuss and Approve District Goals for 2025-2026

10. DISCUSSION ITEMS

- A. Discuss Future Action and Discussion items
- B. Staffing Update
- C. TIA Update
- D. Conferences - SLI or TASA/TASB
- E. Compensation and Benefits Plan
- F. 2530 Committee Presentation

11. Future Board Meeting Dates

12. Executive Session:

As determined by the Board of Trustees, there may be an executive session pursuant to the Texas Open meetings Act (Texas Gov't Code Chapter 551). An Executive Session - may occur at any time during the meeting as permitted under the Open Meetings Act. The list of topics below are some, but not an exhaustive list, of items that would be considered in an executive session:

Personnel (Texas Gov't Code 551.074),
Student Discipline (Texas Gov't Code 551.082),
Attorney consultation (Texas Gov't Code 551.071),
Purchase, exchange, lease or value of real property (Texas Gov't Code 551.072),
Prospective gift (Texas Gov't Code 551.073),
Employee - Employee Complaint (Gov't code 551.082),
Student Discipline Complaint (Gov't Code 551.082),
Security (Gov't Code 551.076)

Any action will be taken in a public session.

- A. Discuss New Hires
- 13. ACTION ITEMS:
(Action Items post executive session are items that must be discussed in executive session. All actions must be taken in an open session.)
 - A. New Hire Recommendations
- 14. Report Items
 - A. Resignations
- 15. ADJOURNMENT:

This agenda was posted on the front door of the school building and on the school district website at: This agenda was posted on the 5th day of May, 2025 at 12:00p.m. on the front door of the school building and the school district website.

Dr. Earl W. Parcell, Superintendent

Dr. Earl W. Parcell, Superintendent



Board of Trustees

Date of Meeting	
Item Type	

Item Name	
District Goal	
Summary (Purpose / Objective)	
Fiscal Impact	
Administrative Recommendation	

Attachments	
-------------	--

Contact Person	<input type="text"/>	E-Mail Address	<input type="text"/>
----------------	----------------------	----------------	----------------------



Board of Trustees

Date of Meeting

Item Type

Item Name	
District Goal	
Summary (Purpose / Objective)	
Fiscal Impact	
Administrative Recommendation	

Attachments	
-------------	--

Contact Person

E-Mail Address



COUPLAND ISD

620 S COMMERCE ST

COUPLAND, TX 78615

512-856-2422

BUDGET WORKSHOP # 1 MINUTES

Date: Thursday, April 10, 2025

Time: 6:00 PM

Location: Coupland School Library
620 S. Commerce Street
Coupland, TX 78615

Board Members:

Crystal Ward – Present

Michael Roepke – Present

Andrew Gonzales – Present

David Young – Present

Tessa Strider – Present

Susan Schmidt – Present

Royce Hatch – Present:

Superintendent:

Dr. Earl Parcell – Present

AGENDA

1. **Call to Order @ 6:05**

2. **Budget Presentation - School Finance Basics**

Dr. Parcell provided a presentation called "School Finance Basics" to the Board.

3. **Public Comment**

4. **Adjourn @ 6:55**

Board President

Date

Board Secretary

Date



COUPLAND ISD

620 S COMMERCE ST

COUPLAND, TX 78615

512-856-2422

REGULAR MEETING MINUTES

Date: Thursday, April 10, 2025

Time: 7:00 PM

Location: Coupland School Library
620 S. Commerce Street
Coupland, TX 78615

Board Members:

Crystal Ward – Present

Michael Roepke – Present

Andrew Gonzales – Present

David Young – Present

Tessa Strider – Present

Susan Schmidt – Present

Royce Hatch – Present:

Superintendent:

Dr. Earl Parcell – Present

AGENDA

1. **Call the meeting to order and establish a quorum. @ 7:04**
2. **Pledge of Allegiance**
Led by: Axel Jaimes Munoz
3. **Recognitions**
4. **Principal's Report**
Mr. Booker reported on teaching and learning as well as campus events and activities.

5. Superintendent's Report

Dr. Parcell reported on enrollment, attendance, growth, achievement, and walk-through data.

6. Public Comments

None

7. Construction Update:

Christine Walker- Claycomb and Associates (Architect)

Randy Boone - Weaver & Jacobs (CMAR)

Mr. Boone provided a PowerPoint presentation detailing the progress at the Coupland Middle School site. The site is prepared and the first piece of the slab will be poured the week of April 14th. Mr. Boone shared steel cross members and beams have been delivered. The anticipated date to begin to stand the steel is around May 5th. Mr. Boone also shared several photos and aerial videos of the project.

Christine Walker provided updates on the overall progress of the project and provided details of the ongoing discussions to secure enough water to satisfy the fire marshal/fire code. Progress is being also being made with the sewer plans.

8. MONTHLY ACTION ITEMS:

A. Consider and Approve the Board of Trustees Meeting Minutes for the Regular Meeting held March 20, 2025.

I move that we Approve the Board of Trustees Meeting Minutes for the Regular Meeting held March 20, 2025.

Motion made by: Susan Schmidt

Seconded by: Royce Hatch

Crystal Ward: Yea, Michael Roepke: Yea, David Young: Yea; Andrew Gonzales: Yea; Tessa Strider: Yea, Susan Schmidt: Yea, Royce Hatch: Yea.

Yea – 7; Nay – 0

B. Approve Monthly Bills and Monthly Financial Reports

I move that we Approve the Monthly Bills and Monthly Financial Reports.

Motion made by: Andrew Gonzales

Seconded by: David Young

Crystal Ward: Yea, Michael Roepke: Yea, David Young: Yea; Andrew Gonzales: Yea; Tessa Strider: Yea, Susan Schmidt: Yea, Royce Hatch: Yea.
Yea – 7; Nay – 0

C. Consider and Approve Budget Amendment

I move that we Approve the Budget Amendment as presented.

Motion made by: Michael Roepke

Seconded by: Susan Schmidt

Crystal Ward: Yea, Michael Roepke: Yea, David Young: Yea; Andrew Gonzales: Yea; Tessa Strider: Yea, Susan Schmidt: Yea, Royce Hatch: Yea.
Yea – 7; Nay – 0

9. APPROVAL OF ADDITIONAL ACTION ITEMS AS NEEDED:

A. Discuss and Consider a Change to the HVAC Units for the New Middle School.

Tabled – No action taken

B. Consider and Approve the 2025-2026 TEKS Certification

I move that we Approve the 2025-2026 TEKS Certification (Certification of Provision of Instructional Materials Survey).

Motion made by: David Young

Seconded by: Michael Roepke

Crystal Ward: Yea, Michael Roepke: Yea, David Young: Yea; Andrew Gonzales: Yea; Tessa Strider: Yea, Susan Schmidt: Yea, Royce Hatch: Yea.
Yea – 7; Nay – 0

C. Consider and Approve a Full-Service Business Solutions Contract with Texas School Finance Center.

I move that we Approve the Full Service Business Solutions Contract with Texas School Finance Center for the 2025-2026.

Motion made by: Susan Schmidt

Seconded by: Royce Hatch

Crystal Ward: Yea, Michael Roepke: Yea, David Young: Yea; Andrew Gonzales: Yea; Tessa Strider: Yea, Susan Schmidt: Yea, Royce Hatch: Yea.
Yea – 7; Nay – 0

D. Consider and Take Action on the Appointment of Investment Officers for CISD

I move that we Approve Dr. Earl Parcell and Lance Terrell as investment officers for CISD for the 2024-2025 fiscal year.

Motion made by: Michael Roepke

Seconded by: Andrew Gonzales

Crystal Ward: Yea, Michael Roepke: Yea, David Young: Yea; Andrew Gonzales: Yea; Tessa Strider: Yea, Susan Schmidt: Yea, Royce Hatch: Yea.
Yea – 7; Nay – 0

E. Consider and Take Action to Revise Policy DEC(LOCAL)

I move that we Approve the Revision to Policy DEC(LOCAL) as presented.

Motion made by: David Young

Seconded by: Crystal Ward

Crystal Ward: Yea, Michael Roepke: Yea, David Young: Yea; Andrew Gonzales: Yea; Tessa Strider: Yea, Susan Schmidt: Yea, Royce Hatch: Yea.
Yea – 7; Nay – 0

F. Consider and Take Action to Authorize the Superintendent to Execute Professional Contracts During the Months of April, May, June, July and August of 2025.

I move that we Authorize the Superintendent to Execute Professional Contracts During the Months of April, May, June, July and August of 2025.

Motion made by: Andrew Gonzales

Seconded by: Michael Roepke

Crystal Ward: Yea, Michael Roepke: Yea, David Young: Yea; Andrew Gonzales: Yea; Tessa Strider: Yea, Susan Schmidt: Yea, Royce Hatch: Yea.
Yea – 7; Nay – 0

10. DISCUSSION ITEMS

A. Discuss Future Action and Discussion items

B. Staffing Update

Dr. Parcell Displayed the organizational chart for 2025-2026 and highlighted the adjustments in staffing due to retirements and programmatic needs.

C. TASB Pay Study Review & Staffing Study

Dr. Parcell shared with the board that the district was engaged with TASB to provide a Staffing Study and a Pay Review which should be completed and presented to the board by early summer.

D. MOU with McDade ISD

Dr. Parcell updated the board on the agreement between McDade ISD and Coupland ISD to mutually terminate the MOU for special education services as of June 30, 2025.

E. Radios

Dr. Parcell mentioned that the newly purchased radios are having a significant impact on campus operations. The staff has embraced the tool and are using them every day (when on the playground and at dismissal).

F. Cowboy Camp 2025

A flier has been sent out through our website to all parents and notifications are also being sent to parents about the 2025 Cowboy Camp with registration scheduled to open on April 18.

G. Board Self-Evaluation

H. Board Goals

11. Future Board Meeting Dates

The next board meeting will be held on May 8th at 6:00 PM.

12. Executive Session:

As determined by the Board of Trustees, there may be an executive session pursuant to the Texas Open meetings Act (Texas Gov't Code Chapter 551). An Executive Session - may occur at any time during the meeting as permitted under the Open Meetings Act. The list of topics below are some, but not an exhaustive list, of items that would be considered in an executive session:

Personnel (Texas Gov't Code 551.074),

**Student Discipline (Texas Gov't Code 551.082),
Attorney consultation (Texas Gov't Code 551.071),
Purchase, exchange, lease or value of real property (Texas Gov't Code 551.072),
Prospective gift (Texas Gov't Code 551.073),
Employee - Employee Complaint (Gov't code 551.082),
Student Discipline Complaint (Gov't Code 551.082),
Security (Gov't Code 551.076)**

Any action will be taken in a public session.

The Board went into executive session at 8:35 PM.

The Board came out of executive session at 10:36 PM.

- A. Discuss Professional Contract Renewals**
- B. Discuss New Hires**
- C. Real Property**

13. ACTION ITEMS:

(Action Items post executive session are items that must be discussed in executive session. All actions must be taken in an open session.)

A. Consider and Take Action to Renew Professional Staff Contracts

No action taken

B. New Hire Recommendations

I move that we Approve the New Hires as presented.

Motion made by: Susan Schmidt

Seconded by: Royce Hatch

Crystal Ward: Yea, Michael Roepke: Yea, David Young: Yea; Andrew Gonzales: Yea; Tessa Strider: Yea, Susan Schmidt: Yea, Royce Hatch: Yea.

Yea – 7; Nay – 0

C. Consideration and possible action regarding the possible donation of right of way/land of the District's property described as follows: 1.355 acres (59,044 square feet) tract or parcel of land situated in the Joseph Jordan Survey, Abstract No. 357, Williamson County, Texas, and being a portion of a called 61.7162 acre tract of land described in the deed to Coupland Independent School District, recorded in instrument No. 2007071605, said official public records of Williamson County, Texas. The donation of land is for public

purposes for the construction of a road part of the County’s 2023 Bond Program CR 460. The Board will further consider a resolution declaring the property is not needed for educational purposes and the District will receive a benefit from the donation.

I move the Board to authorize the Superintendent and Board President to continue negotiating a possible donation of District’s property described as 1.355 acres (59,044 square feet) tract or parcel of land situated in the Joseph Jordan Survey, Abstract No. 357, Williamson County, Texas, and being a portion of a called 61.7162 acre tract of land described in the deed to Coupland Independent School District, recorded in instrument No. 2007071605, said official public records of Williamson County, Texas. The authorization included scheduling and calling for a public hearing pursuant to Texas Education Code. The possible donation is for public purposes for the construction of a road being part of Williamson County’s 2023 Bond Program CR 460.

Motion made by: Crystal Ward

Seconded by: Royce Hatch

Crystal Ward: Yea, Michael Roepke: Yea, David Young: Yea; Andrew Gonzales: Yea; Tessa Strider: Yea, Susan Schmidt: Yea, Royce Hatch: Yea.
Yea – 7; Nay – 0

14. Report Items

A. Resignations

15. ADJOURNMENT: @ 10:39

I Move that we adjourn.

Motion made by: Michael Roepke

Seconded by: Andrew Gonzales

Crystal Ward: Yea, Michael Roepke: Yea, David Young: Yea; Andrew Gonzales: Yea; Tessa Strider: Yea, Susan Schmidt: Yea, Royce Hatch: Yea.
Yea – 7; Nay – 0

Board President Date

Board Secretary Date



Board of Trustees

Date of Meeting

Item Type

Item Name	
District Goal	
Summary (Purpose / Objective)	
Fiscal Impact	
Administrative Recommendation	

Attachments	
-------------	--

Contact Person

E-Mail Address

COUPLAND INDEPENDENT SCHOOL DISTRICT

GENERAL FUND FINANCIAL STATEMENT

Fund 199
APRIL 2025



	2024-2025			2023-2024		
	Current Budget	Actual	Actual to Budget	Current Budget	Actual	Actual to Budget
REVENUES:						
Local and Intermediate Sources	\$ 2,183,205	\$ 2,250,564	103.09%	\$ 2,233,999	\$ 2,143,922	95.97%
State Program Revenues	2,610,521	2,274,360	87.12%	1,832,545	1,938,829	105.80%
Federal Program Revenues	14,500	-	0.00%	12,445	-	0.00%
Other Financing Sources	-	-	0.00%	-	-	0.00%
Total Revenues	\$ 4,808,226	\$ 4,524,924	94.11%	\$ 4,078,989	\$ 4,082,751	100.09%
EXPENDITURE SUMMARY BY FUNCTION:						
11 - Instructional	\$ 2,904,321	\$ 1,814,035	62.46%	\$ 2,228,183	\$ 1,377,172	61.81%
12 - Instructional Resources and Media Services	7,850	6,190	78.86%	21,100	7,185	34.05%
13 - Curriculum and Instructional Staff Development	19,700	30	0.15%	18,950	3,288	17.35%
21 - Instructional Leadership	12,362	-	0.00%	2,150	575	26.74%
23 - School Leadership	320,173	201,634	62.98%	285,307	182,657	64.02%
31 - Guidance, Counseling and Evaluation	174,769	127,455	72.93%	175,522	104,506	59.54%
33 - Health Services	3,550	1,415	39.86%	6,400	367	5.73%
34 - Student Transportation	275,192	190,817	69.34%	179,542	113,061	62.97%
35 - Food Service	2,059	2,059	99.99%	-	-	
36 - Cocurricular/Extra Curricular Activities	27,714	18,351	66.21%	33,022	17,527	53.08%
41 - General Administration	368,356	231,341	62.80%	400,670	271,293	67.71%
51 - Plant Maintenance and Facility Services	363,425	225,661	62.09%	394,505	216,224	54.81%
52 - Security and Monitoring Services	48,750	20,550	42.15%	39,000	22,051	56.54%
53 - Data Processing Services	247,658	168,876	68.19%	186,512	130,836	70.15%
61 - Community Services	500	-	0.00%	-	-	
71 - Debt Service	66,436	66,435	100.00%	69,000	66,370	96.19%
81 - Capital Outlay	-	-	0.00%	-	-	
93 - Payments to Fiscal Agents	-	-		-	-	
99 - Other intergovernmental Charges	25,000	17,415	69.66%	14,000	14,615	104.39%
Operating Transfer to Cafeteria	9,681	-	0.00%	25,126	-	0.00%
Total Expenditures	\$ 4,877,496	\$ 3,092,265	63.40%	\$ 4,078,989	\$ 2,527,727	61.97%
EXPENDITURE SUMMARY BY OBJECT CODE:						
61XX - Payroll Costs	\$ 3,776,173	\$ 2,406,842	63.74%	\$ 3,070,341	\$ 1,902,239	61.96%
62XX - Professional and Contracted Services	547,524	320,419	58.52%	497,564	345,827	69.50%
63XX - Supplies and Materials	197,420	94,903	48.07%	257,334	102,866	39.97%
64XX - Other Operating Expenses	160,262	83,665	52.21%	93,624	55,130	58.88%
65XX - Debt Service - Principal	66,436	66,435	100.00%	69,000	66,370	96.19%
66XX - Capital Outlay Expenses	120,000	120,000	100.00%	66,000	55,295	83.78%
Operating Transfers	9,681	-	0.00%	25,126	-	0.00%
Total Expenditures	\$ 4,877,496	\$ 3,092,265	63.40%	\$ 4,078,989	\$ 2,527,727	61.97%



COUPLAND INDEPENDENT SCHOOL DISTRICT
CHILD NUTRITION FUND FINANCIAL STATEMENT
Fund 240
APRIL 2025

	2024-2025			2023-2024		
	Current Budget	Actual	Actual to Budget	Current Budget	Actual	Actual to Budget
REVENUES:						
Local and Intermediate Sources	\$ 60,000	\$ 53,668	89.45%	\$ 67,300	\$ 51,995	77.26%
State Program Revenues	11,058	1,372	12.40%	26,854	20,317	75.66%
Federal Program Revenues	167,000	121,167	72.56%	139,506	107,207	76.85%
Other Financing Sources	9,681	-	0.00%	25,126	-	0.00%
Total Revenues	\$ 247,739	\$ 176,207	71.13%	\$ 258,786	\$ 179,519	69.37%
EXPENDITURES:						
35 - Food Services	\$ 247,739	\$ 173,123	69.88%	\$ 258,876	\$ 154,182	59.56%
Total Expenditures	\$ 247,739	\$ 173,123	69.88%	\$ 258,876	\$ 154,182	59.56%
EXPENDITURE SUMMARY BY OBJECT CODE:						
61XX - Payroll Costs	\$ 142,039	\$ 90,719	63.87%	\$ 135,912	\$ 81,707	60.12%
62XX - Professional and Contracted Services	6,500	-	0.00%	11,500	434	3.77%
63XX - Supplies and Materials	98,500	82,404	83.66%	110,674	71,799	64.87%
64XX - Other Operating Expenses	700	-	0.00%	700	242	34.57%
64XX - Other Operating Expenses	-	-	0.00%	-	-	-
Total Expenditures	\$ 247,739	\$ 173,123	69.88%	\$ 258,786	\$ 154,182	59.58%



COUPLAND INDEPENDENT SCHOOL DISTRICT
DEBT SERVICE FUND FINANCIAL STATEMENT
Fund 599
APRIL 2025

	2024-2025			2023-2024		
	Current Budget	Actual	Actual to Budget	Current Budget	Actual	Actual to Budget
REVENUES:						
Local and Intermediate Sources	\$ 1,547,519	\$ 1,563,557	101.04%	\$ 1,550,025	\$ 1,413,358	91.18%
State Program Revenue	\$ 92,381	\$ 89,831	97.24%	\$ -	\$ 14,564	
Total Revenues	\$ 1,639,900	\$ 1,653,388	100.82%	\$ 1,550,025	\$ 1,427,922	92.12%
EXPENDITURES:						
71 - Debt Service	\$ 1,639,900	\$ 1,040,400	63.44%	\$ 1,550,025	\$ 959,619	61.91%
Total Expenditures	\$ 1,639,900	\$ 1,040,400	63.44%	\$ 1,550,025	\$ 959,619	61.91%
EXPENDITURE SUMMARY BY OBJECT CODE:						
65XX - Debt Service Expenses	1,639,900	1,040,400	63.44%	1,550,025	959,619	61.91%
Total Expenditures	\$ 1,639,900	\$ 1,040,400	63.44%	\$ 1,550,025	\$ 959,619	61.91%

Check Payments
 COUPLAND ISD
 District Written Checks
 For the Month of April

Check Nbr	Check Date	Payee	PO Nbr	Invoice Nbr	Fnd-Fnc-Obj.So-Org-Prog	Reason	Amount	EFT
000408	04-08-2025	WEAVER & JACOBS CO	350358	Draw 6	699-81-6629.00-999-599000	Const Draw 6	353,623.26	N
000408	04-08-2025	ZIONS BANCORPORATI	350342	220581	199-71-6513.00-101-599000	Loan Payment 4/15	55,000.00	N
			350342	220581	199-71-6523.00-101-599000	Loan Payment 4/15	5,000.00	N
			350342	220581	199-71-6523.00-101-599000	Loan Payment 4/15	717.65	N
Totals for Check 000408							60,717.65	
001281	04-03-2025	BRANDI SMITH	250131	Lowes Walmart	461-36-6399.00-101-599000	Sympathy Cards and plants	68.40	N
001282	04-08-2025	CHASE INK	350325	716209	461-12-6399.00-000-500000	Amazon Library Books	39.96	N
			250138	4354611	461-36-6399.02-101-599000	Lollipops for Student Council	132.90	N
Totals for Check 001282							172.86	
001283	04-16-2025	FOLLETT CONTENT SOL	350317	541287F	461-12-6399.00-000-500000	Library Books	346.68	N
007642	04-11-2025	COMBINED BENEFITS G	DEDCH		863-00-2153.00-012-500000	APR DED HEALTH INSURANCE	201.42	N
			DEDCH		863-00-2153.00-013-500000	APR DED HEALTH INSURANCE	200.23	N
			DEDCH		863-00-2153.00-015-500000	APR DED LIFE INSURANCE	239.50	N
			DEDCH		863-00-2153.00-016-500000	APR DED HEALTH INSURANCE	179.00	N
			DEDCH		863-00-2153.00-022-500000	APR DED HEALTH INSURANCE	239.48	N
			DEDCH		863-00-2153.00-026-500000	APR DED HEALTH INSURANCE	941.12	N
			DEDCH		863-00-2153.00-027-500000	APR DED HEALTH INSURANCE	1,429.94	N
			DEDCH		863-00-2153.00-029-500000	APR DED LIFE INSURANCE	511.83	N
			DEDCH		863-00-2153.00-035-500000	APR DED HEALTH INSURANCE	86.40	N
			DEDCH		863-00-2153.00-105-500000	APR DED HEALTH INSURANCE	103.00	N
			DEDCH		863-00-2153.00-106-500000	APR DED HEALTH INSURANCE	126.36	N
			DEDCH		863-00-2153.00-107-500000	APR DED LIFE INSURANCE	86.70	N
			DEDCH		863-00-2153.00-108-500000	APR DED HEALTH INSURANCE	63.00	N
			DEDCH		863-00-2153.00-111-500000	APR DED LIFE INSURANCE	43.01	N
			DEDCH		863-00-2159.00-037-500000	APR DED MISCELLANEOUS DEDU	804.99	N
			DEDCH		863-00-2159.00-100-500000	APR DED HSA	120.00	N
			DEDCH		863-00-2159.00-101-500000	APR DED MISCELLANEOUS DEDU	48.98	N
			DEDCH		863-00-2159.00-110-500000	APR DED MISCELLANEOUS DEDU	103.17	N
Totals for Check 007642							5,528.13	
007643	04-11-2025	NATIONAL BENEFIT SER	DEDCH		863-00-2159.00-034-500000	APR DED TAX SHEL. ANNUITY	250.00	N
			DEDCH		863-00-2159.00-042-500000	APR DED TAX SHEL. ANNUITY	500.00	N
			DEDCH		863-00-2159.00-102-500000	APR DED TAX SHEL. ANNUITY	100.00	N
			DEDCH		863-00-2159.00-103-500000	APR DED TAX SHEL. ANNUITY	575.00	N
Totals for Check 007643							1,425.00	
007644	04-11-2025	TCTA	DEDCH		863-00-2159.00-006-500000	APR DED TSTA DUES	61.50	N
007645	04-11-2025	TEXAS STATE DISBURS	DEDCH		863-00-2159.00-019-500000	APR DED MISCELLANEOUS DEDU	829.66	N
IRS04A	04-18-2025	UNITED STATES TREAS	DEDCH		863-00-2151.00-000-500000	APR WIRE PAYROLL DEDUCTION	15,744.11	N
			DEDCH		863-00-2152.01-000-500000	APR WIRE PAYROLL DEDUCTION	3,968.87	N
			DEDCH		863-00-2152.02-000-500000	APR WIRE PAYROLL DEDUCTION	3,968.87	N
Totals for Check IRS04A							23,681.85	
TRS03	04-01-2025	TRS	DEDCH		863-00-2155.00-000-500000	APR WIRE PAYROLL DEDUCTION	21,691.78	N
			DEDCH		863-00-2155.01-000-500000	APR WIRE PAYROLL DEDUCTION	767.31	N
			DEDCH		863-00-2155.02-000-500000	APR WIRE PAYROLL DEDUCTION	4,240.17	N

Check Payments
 COUPLAND ISD
 District Written Checks
 For the Month of April

Check Nbr	Check Date	Payee	PO Nbr	Invoice Nbr	Fnd-Fnc-Obj.So-Org-Prog	Reason	Amount	EFT
			DEDCH		863-00-2155.03-000-500000	APR WIRE PAYROLL DEDUCTION	116.25	N
			DEDCH		863-00-2155.04-000-500000	APR WIRE PAYROLL DEDUCTION	1,827.99	N
			DEDCH		863-00-2155.05-000-500000	APR WIRE PAYROLL DEDUCTION	141.57	N
			DEDCH		863-00-2155.06-000-500000	APR WIRE PAYROLL DEDUCTION	3,010.21	N
			DEDCH		863-00-2155.07-000-500000	APR WIRE PAYROLL DEDUCTION	1,070.00	N
			DEDCH		863-00-2155.08-000-500000	APR WIRE PAYROLL DEDUCTION	3,846.64	N
					Totals for Check TRS03C		36,711.92	
TRS4B	04-15-2025	TRS	DEDCH		863-00-2153.00-050-500000	APR WIRE PAYROLL DEDUCTION	7,923.00	N
			DEDCH		863-00-2153.00-051-500000	APR WIRE PAYROLL DEDUCTION	3,266.00	N
			DEDCH		863-00-2153.00-052-500000	APR WIRE PAYROLL DEDUCTION	13,574.00	N
					Totals for Check TRS4B		24,763.00	
					Total For District Written Checks		507,929.91	

Check Payments
 COUPLAND ISD
 Computer Written Checks
 For the Month of April

Check Nbr	Check Date	Payee	PO Nbr	Invoice Nbr	Fnd-Fnc-Obj.So-Org-Prog	Reason	Amount	EFT
020231	04-03-2025	AEROWAVE TECHNOLO	350259	INV9447	429-52-6399.01-000-400000	2 WAY RADIOS	60,882.37	N
020232	04-03-2025	BRIAN BOOKER	350356	Reg 13 Reimb	199-11-6499.00-101-511000	Reg 13 Reimb	299.42	N
020233	04-03-2025	BROTHERS FOOD	250124	1759016	240-35-6341.00-101-599000	Produce	374.55	N
020234	04-03-2025	CLASSLINK INC	350336	e-120072	199-53-6299.05-101-599000	Subscription renewal	2,477.25	N
020235	04-03-2025	EARL PARCELL	250125	368221 HEB	199-41-6399.00-701-599000	Snacks & Drinks for 2530	86.09	N
020236	04-03-2025	FERGUSON FACILITIES	350344	1787829	199-11-6399.05-101-523000	Gloves Life Skills	50.60	N
020237	04-03-2025	GOLD STAR FOODS INC	250126	319586	240-35-6341.00-101-599000	Cn Food Purchase	158.34	N
020238	04-03-2025	AFFORDABLE SIGNS	350351		199-11-6397.00-101-599000	Bumper Stickers	1,075.00	N
020239	04-03-2025	GULF COAST PAPER CO	250127	2633646	240-35-6342.00-101-599000	CN Cups, sporks & supplies	375.39	N
			250127	2633662	240-35-6342.00-101-599000	CN Cups, sporks & supplies	47.28	N
Totals for Check 020239							422.67	
020240	04-03-2025	HILAND DAIRY FOODS C	250128	9028457	240-35-6341.02-101-599000	CN Milk Purchase	319.83	N
			250128	7030858	240-35-6341.02-101-599000	CN Milk Purchase	21.89	N
			250128	9023017	240-35-6341.02-101-599000	CN Milk Purchase	281.77	N
			250128	9033335	240-35-6341.02-101-599000	CN Milk Purchase	297.94	N
			250128	9034361	240-35-6341.02-101-599000	CN Milk Purchase	218.71	N
			250128	9035965	240-35-6341.02-101-599000	CN Milk Purchase	255.83	N
			250128	9037165	240-35-6341.02-101-599000	CN Milk Purchase	218.71	N
Totals for Check 020240							1,614.68	
020241	04-03-2025	UNIFIED CONNEXIONS	350360	1003786	199-53-6299.01-101-599000	VEEAM Immut Backup	3,150.00	N
020242	04-03-2025	LA COSTENITA DISTRIB	250130	16146	240-35-6341.00-101-599000	Ice Cream	209.52	N
020243	04-03-2025	TEXAS THERAPY SPECI	350367	Oct Nov Dec	199-11-6219.00-101-523000	Oct Nov Dec Speech Ther	2,568.75	N
020244	04-03-2025	FERGUSON FACILITIES	350313	1703597-1	199-51-6319.00-101-599000	Custodial Supplies	71.94	N
020245	04-03-2025	MSB CONSULTING GRO	350346	FF228253	199-11-6299.00-101-523000	Cost Report Fee	1,500.00	N
020246	04-03-2025	QUILL	350330	43380497	199-11-6399.00-101-511000	PO Created by Req: 250353	59.58	N
			350331	43387638	199-11-6399.02-101-537000	Paper	250.00	N
			350331	43387638	199-11-6399.05-101-523000	Paper	250.00	N
			350331		199-23-6399.00-101-599000	Paper	468.75	N
Totals for Check 020246							1,028.33	
020247	04-03-2025	RENAISSANCE INSTITUT	350090	1994	199-53-6299.14-101-599000	Renaissance Inst 24-25	4,000.00	N
020248	04-03-2025	SPECTRUM	350091	10480050103212	199-51-6259.01-101-599000	Telephone &	1,402.11	N
			350091	10480050103212	199-53-6299.15-101-599000	Internet	1,827.99	N
Totals for Check 020248							3,230.10	
020249	04-03-2025	TASA	350049	164541	199-41-6411.00-701-599000	Superintendents Academy	245.00	N
			350049	164540	199-41-6411.00-701-599000	Superintendents Academy	245.00	N
Totals for Check 020249							490.00	
020250	04-03-2025	FUELMAN	250129	191174 03	199-34-6311.00-101-599000	Gas for Bus	2,002.62	N
			250129	191174 03 fee	199-34-6311.00-101-599000	Fleet Fuel Card Fee	35.94	N
				191174 03	199-34-6311.00-101-599000	Discount for Fuel Card	-225.30	N
Totals for Check 020250							1,813.26	

Check Payments
 COUPLAND ISD
 Computer Written Checks
 For the Month of April

Check Nbr	Check Date	Payee	PO Nbr	Invoice Nbr	Fnd-Fnc-Obj.So-Org-Prog	Reason	Amount	EFT
020251	04-03-2025	TRIUMPH PROTECTION	350036	INV021513	429-52-6299.00-101-399000	Security Officer 9/1 - 3/30/25	1,316.00	N
			350036	INV21692	429-52-6299.00-101-399000	Security Officer 9/1 - 3/30/25	1,032.00	N
Totals for Check 020251							2,348.00	
020252	04-03-2025	UMB BANK NA	350349	1005168	599-71-6599.00-101-599000	Paying Agent Fee	500.00	N
020253	04-03-2025	VANESSA DECESARI	350363	Feb 2025	199-11-6219.01-101-523000	PT Services Nov and Feb	160.00	N
			350363	Nov 2024	199-11-6219.01-101-523000	PT Services Nov and Feb	350.00	N
Totals for Check 020253							510.00	
020254	04-03-2025	WALSH GALLEGOS TRE	350359	5875	199-41-6211.00-701-599000	Legal Services	787.50	N
020255	04-03-2025	WASTE MANAGEMENT	350107	0208176-2161-6	199-51-6249.00-101-599000	Trash Pickup	695.99	N
020256	04-09-2025	CHASE INK	350312	0942664	199-11-6399.00-101-511000	supplies	14.38	N
			350319	6313815	199-11-6399.00-101-511000	Noise canceling headphones	164.30	N
			250137	2150649	199-11-6399.00-101-511000	Hot and cold packs	258.22	N
			350325	6361850	199-12-6399.00-101-599000	Amazon Library Books	136.43	N
			350325	2058645	199-12-6399.00-101-599000	Amazon Library Books	24.60	N
			350325	7172226	199-12-6399.00-101-599000	Amazon Library Books	119.89	N
			350318	80325304	199-23-6399.00-101-599000	Registration banner	295.23	N
				Hebbe Travel	199-31-6411.00-101-523000	Refund of hotel tax	-19.08	N
			250137	2150649	199-33-6399.00-101-599000	Hot and cold packs	27.20	N
			350348	1585730	199-34-6499.00-101-599000	CTRMA Toll Bill	7.68	N
			250133	WM 3765	199-36-6399.00-101-591000	UIL Award	113.42	N
			250133	WM 4617	199-36-6399.00-101-591000	UIL Award	31.29	N
			350312	3865846	199-36-6399.00-101-591000	supplies	32.00	N
			350341	73	199-36-6412.01-101-591000	Meals for Gause Track Meet	74.00	N
			350341	60	199-36-6412.01-101-591000	Meals for Gause Track Meet	62.50	N
			350347	7537043	199-41-6399.00-701-599000	Front office scanner peims	329.99	N
			350347	3426663	199-41-6399.00-701-599000	Front office scanner peims	31.17	N
350339	TIA	199-41-6399.00-701-599000	TIA Renewal Fee	2,556.51	N			
350328	03242025	199-41-6411.01-701-599000	PFIA Training Parcell	120.00	N			
350311	07295G	199-51-6319.01-101-599000	Sand and Supplies	58.85	N			
250134	407722	199-53-6299.09-101-599000	Screen Cloud Renewal	750.00	N			
250135	03302025	199-53-6299.10-101-599000	Adobe License - creat cloud	1,943.52	N			
250132	WM 4017	240-35-6341.00-101-599000	CN Walmart food purchase	48.66	N			
250136	2211460	240-35-6399.00-101-599000	Lightbulb Cafeteria	61.46	N			
Totals for Check 020256							7,242.22	
020257	04-10-2025	A-LINE AUTO PARTS	350371	11128146	199-34-6319.00-101-599000	Oil/filter for bus	103.03	N
020258	04-10-2025	DIRECT ENERGY BUSIN	350108	25091005665290	199-51-6259.02-101-599000	Electricity	4,702.55	N
020259	04-10-2025	GREATAMERICA	350099	38953934	199-23-6269.00-101-599000	Copier Lease	141.18	N
020260	04-10-2025	LA COSTENITA DISTRIB	250140	16274	240-35-6341.00-101-599000	Ice Cream	185.04	N
020261	04-10-2025	LABATT FOOD SERVICE	250139	3045083	240-35-6341.00-101-599000	CN Food Purchase	2,200.12	N
			250139	3189675	240-35-6341.00-101-599000	CN Food Purchase	1,988.41	N
			250139	3250046	240-35-6341.00-101-599000	CN Food Purchase	2,010.77	N
			250139	3250046	240-35-6342.00-101-599000	CN Food Purchase	84.03	N
Totals for Check 020261							6,283.33	

Check Payments
 COUPLAND ISD
 Computer Written Checks
 For the Month of April

Check Nbr	Check Date	Payee	PO Nbr	Invoice Nbr	Fnd-Fnc-Obj.So-Org-Prog	Reason	Amount	EFT
020262	04-10-2025	LEASOR CRASS, P.C.	350378	26734	199-41-6211.00-701-599000	LC Legal	217.00	N
			350379	26560	199-41-6211.00-701-599000	LC Legal	1,054.00	N
Totals for Check 020262							1,271.00	
020263	04-10-2025	LITTLE PINES PEDIATRI	350385	03 2025	199-11-6219.01-101-523000	Occ Therapy Mar 2025	1,020.00	N
020264	04-10-2025	LOWE'S	350322	996823	199-51-6319.01-101-599000	Building Supplies	462.61	N
020265	04-10-2025	TEXAS THERAPY SPECI	350383	01 2025	199-11-6219.00-101-523000	Speech Svcs Jan	1,200.00	N
			350383	02 2025	199-11-6219.00-101-523000	Speech Svcs Feb	2,118.75	N
Totals for Check 020265							3,318.75	
020266	04-10-2025	TOSHIBA FINANCIAL SE	350100	589866475	199-11-6269.00-101-599000	Copier Lease	593.64	N
020267	04-10-2025	TRAVIS COUNTY ELECTI	350377	91	199-41-6439.00-702-599000	Cost Reimb Vot Equip	17.33	N
020268	04-10-2025	TRINITY EDUCATIONAL	350380	7061	199-11-6219.00-101-523000	Bilingual Evals Mar 25	4,820.00	N
				5772	199-11-6219.00-101-523000	Credit for invoice 5772 error	-850.00	N
				5807	199-11-6219.00-101-523000	Credit for invoice 5807 error	-1,483.75	N
Totals for Check 020268							2,486.25	
020269	04-16-2025	DELL MARKETING L.P.	350369	10809240372	199-53-6399.00-101-599000	6- Dell Latitude computers	5,181.18	N
020270	04-16-2025	FOLLETT CONTENT SOL	350326	1573826	199-12-6399.00-101-599000	Barcode Scanner & labels	184.83	N
020271	04-16-2025	GULF COAST PAPER CO	250141	2638499	240-35-6342.00-101-599000	CN Cups, Sporks and other supp	218.10	N
020272	04-16-2025	LA COSTENITA DISTRIB	250143	16376	240-35-6341.00-101-599000	Ice Cream	181.44	N
020273	04-16-2025	PEST PATROL	350106	350106	199-51-6249.03-101-599000	Pest Treatment	250.00	N
020274	04-16-2025	TRIUMPH PROTECTION	350036	INV021865	429-52-6299.00-101-399000	Security Officer 9/1 - 3/30/25	1,296.00	N
020275	04-24-2025	ACHIEVE FINANCIAL GR	350368	2025-Coupland	199-36-6429.00-101-599000	Student Accident Coverage	1,955.00	N
020276	04-24-2025	APPLE INC	350355	MB65922661	199-53-6399.00-101-599000	2 Ipads - Apple Pencil	69.00	N
020277	04-24-2025	BROTHERS FOOD	250144	01766996	240-35-6341.00-101-599000	Produce	291.05	N
020278	04-24-2025	GULF COAST PAPER CO	250145	2640740	240-35-6342.00-101-599000	CN Cups, sporks & supplies	40.80	N
020279	04-24-2025	HEARTLAND PAYMENT	350353	3092159	199-53-6399.00-101-599000	POS Terminal scanner	2,432.00	N
020280	04-24-2025	MANVILLE WATER SUPP	350109	601151 0425	199-51-6259.00-101-599000	Water Bill	363.19	N
			350109	2138551 0425	199-51-6259.00-101-599000	Water Bill	313.02	N
			350109	2106541 0425	199-51-6259.00-101-599000	Water Bill	161.08	N
Totals for Check 020280							837.29	
020281	04-24-2025	TRIUMPH PROTECTION	350036	INV22059	429-52-6299.00-101-399000	Security Officer 9/1 - 3/30/25	1,272.00	N
			350036	INV022121	429-52-6299.00-101-399000	Security Officer 9/1 - 3/30/25	1,024.00	N
Totals for Check 020281							2,296.00	
020282	04-24-2025	ZANER-BLOSER, INC.	350370	INVZB72594	199-11-6397.01-101-511000	Handwriting 1-5 for 25/26	3,081.32	N
020283	04-30-2025	APPLE INC	350355	MB68199450	199-53-6399.00-101-599000	2 Ipads - Apple Pencil	658.00	N
020284	04-30-2025	FOLLETT CONTENT SOL	350326	1576118	199-12-6399.00-101-599000	Barcode Scanner & labels	125.96	N
020285	04-30-2025	GULF COAST PAPER CO	250146	2647219	240-35-6342.00-101-599000	CN Cups, Sporks and other supp	319.45	N

Check Payments
 COUPLAND ISD
 Computer Written Checks
 For the Month of April

Check Nbr	Check Date	Payee	PO Nbr	Invoice Nbr	Fnd-Fnc-Obj.So-Org-Prog	Reason	Amount	EFT
020286	04-30-2025	FERGUSON FACILITIES	350376	1829060	199-51-6319.00-101-599000	Supplies	1,958.18	N
020287	04-30-2025	SPECTRUM	350091	10480005014021	199-51-6259.01-101-599000	Telephone	1,397.41	N
			350091	10480050104212	199-53-6299.15-101-599000	Internet	1,827.10	N
Totals for Check 020287							3,224.51	
020288	04-30-2025	FUELMAN	250147	NP68310896	199-34-6311.00-101-599000	Gas for Bus	1,619.95	N
			250147	NP68310896	199-34-6311.00-101-599000	Gas for Bus Card Fee	41.93	N
				NP68310896	199-34-6311.00-101-599000	Discount for Fuel Card	-233.76	N
Totals for Check 020288							1,428.12	
020289	04-30-2025	WASTE MANAGEMENT	350107	0209346-2161-4	199-51-6249.00-101-599000	Trash Pickup	693.48	N
Total For Computer Written Checks							144,893.00	
Total Checks							652,822.91	

End of Report



Board of Trustees

Date of Meeting

Item Type

Item Name	
District Goal	
Summary (Purpose / Objective)	
Fiscal Impact	
Administrative Recommendation	

Attachments	
-------------	--

Contact Person

E-Mail Address

AGREEMENT FOR DONATION OF REAL PROPERTY

CR 460 Right of Way

THIS AGREEMENT FOR DONATION OF REAL PROPERTY ("Agreement") is entered into as of the date set forth below by and between **COUPLAND INDEPENDENT SCHOOL DISTRICT**, hereinafter referred to as "Donor," and the **WILLIAMSON COUNTY, TEXAS**, hereinafter referred to as "County". Donor desires to donate to County, and County desires to accept from Donor, the property which is more particularly identified as approximately 1.355 acre in Exhibit "A" attached hereto (collectively the "Parcel").

IN CONSIDERATION of the mutual covenants set forth herein, Donor and County hereby agree as follows:

Section 1. Transfer & Acceptance.

- a. Donor shall convey and grant indefeasible title in and to the Parcel, free and clear of any monetary liens and encumbrances after title inspection by County at its sole expense, to County by deed in the form as shown in Exhibit "B" attached hereto. The deed shall be fully executed, notarized, and delivered to County by Donor within thirty (30) days following final approval and execution of this Agreement by County, completion of metes and bounds property surveys for the Parcel at County's sole expense, and recording of any release of liens or other title curative items.
- b. The County accepts the public dedication of the Parcel from the Donor. The County shall accept from the Donor title to, and interest in, the Parcel.

Section 2. Consideration. As a condition and in consideration of Donor's conveyance of the Parcel to County, the County agrees to the following:

- a. Construction of traffic control improvements. As an obligation which shall survive the completion of the conveyance of the Parcel by Donor herein, County agrees at its sole cost to cause the following additional traffic control and signalization improvements within the Parcel and other property owned or acquired by County to be constructed as part of its proposed 2023 Bond Program CR 460 roadway improvement project (the "School Traffic Control Improvements"):

Sign No	Sign Nomenclature
1	S1-1 / W16-9P
4	S5-2 / R2-1
5	S5-1
10	S5-1
11	S5-2 / R2-1
14	S1-1 / W16-9P

Pavement Marking

- 24" (W) SLD School Zone Limit

The School Traffic Control Improvements shall be constructed by County in substantial compliance with the plans, notes, location and specifications as shown in Exhibit “C” attached hereto and incorporated herein (the “Plans”).

The School Traffic Control Improvements shall be constructed and completed by County at the same time as the construction of that section of the road, pursuant to Exhibit C.

Section 3. Representations and Warranties. The County hereby represents and warrants that:

- a. County accepts the Parcel **AS IS, IN ITS PRESENT CONDITION.**

Section 4. Donor’s Duties, Representations and Warranties.

- a. Donor shall be responsible for the prorated payment of General real estate taxes, if any, for the then current year relating to the Parcel through the date of Deed conveyance described herein. Agricultural roll-back taxes which directly result from this conveyance, if any, shall be paid by County.
- b. Donor may realize any proper tax benefit or future Road District reimbursement to which it is entitled through this gift of real property, and County shall provide any reasonable assistance requested by Donor to complete any required documentation for same.
- c. Donor understands and acknowledges that Donor has been informed of the entitlement to receive fair market value payment for the Parcel, as set out in Title III of the Uniform Relocation Assistance and Real Property Acquisition Policies Act of 1970 (42 U.S.C. 4601-4655), and the legal right to an appraisal, and is waiving those rights.
- d. *Traffic Control Improvements Maintenance.* As an obligation which shall survive the conveyance of the Parcel, Donor shall be responsible for all operation and maintenance of the School Traffic Control Improvements described herein at its sole cost following completion of construction and acceptance by County in accordance with the Plans.

Section 5. Reverter. In the event that the Property described in this Agreement ceases to be used by the County or other political subdivision or municipality for the purposes expressly stated herein—namely, a road section of the County’s 2023 Bond Program CR 460 roadway improvement project, or if the County attempts to sell, lease, transfer, encumber, or otherwise dispose of the Property to an entity which does not have the power of condemnation without the prior written consent of the Donor or the Donor’s successors or assigns,

the title to the Property shall automatically revert to the Donor or the Donor's successors or assigns.

Such reversion shall occur upon written notice from the Donor to the County, specifying the nature of the breach. If the County fails to cure such breach within ninety (90) days of receipt of such notice, title to the Property shall revert without further action required, and the County agrees to execute any documents necessary to effectuate such reversion.

The County shall not take any action that would impair or limit the Donor's reversionary interest in the Property. This clause shall run with the land and shall be binding upon all successors and assigns of the County.

Section 6. Assigns; Beneficiaries. Neither the County nor Donor shall have the right to assign this Agreement to any party. Subject to the foregoing, this Agreement shall inure to the benefit of and be binding upon the parties hereto and their respective successors and assigns. This Agreement is for the sole benefit of Donor and County. Once County has vested title to the Parcel it may only be transferred to another governmental entity with the power of condemnation for the stated uses as described herein.

Section 7. Entire Agreement. This Agreement is the entire agreement between Donor and County concerning the gift of interest in the Parcel, and no modification hereof or subsequent agreement relative to the subject matter hereof shall be binding on either party unless reduced to writing and signed by the party to be bound.

Section 8. Choice of Law; Venue; Dispute Resolution. This Agreement will be construed under the laws of the State of Texas, without regard to choice-of-law rules of any jurisdiction. Venue for any action brought under or with regard to this Agreement or the breach of this Agreement is in Williamson County, Texas, except to the extent otherwise mandated by applicable law. Time permitting, the parties will submit in good faith to an alternative dispute resolution process before filing a suit concerning this Agreement or the breach of same.

[signature page follows]

EXECUTED BY the County and by Donor as follows:

DONOR:

COUPLAND INDEPENDENT SCHOOL DISTRICT

By: _____

Name: _____

Its: _____

Date: _____

COUNTY:

WILLIAMSON COUNTY, TEXAS

By: _____

Name: _____
County Judge/Presiding Officer

Date: _____

EXHIBIT "A"

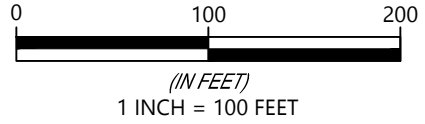

A CALLED 66.183 ACRES
UNNAM 1050 FM 1466 COUPLAND TX LLC
INSTRUMENT NO. 2022113522
O.P.R.W.C.T.

A CALLED 11.43 ACRES
PABLO LOPEZ
INSTRUMENT NO. 2020012353
O.P.R.W.C.T.

STA 23+21.59
67.53' LT

1/2" IRF
STA 23+20.91
14.29' LT

STA 19+20.81
14.67' LT

PROPOSED RIGHT-OF-WAY
1.355 ACRES
(59,044 SQ FT)

JOSEPH JORDAN SURVEY
ABSTRACT NO. 357

A CALLED 10.00 ACRES
ROBERT MILTON TEDFORD
INSTRUMENT NO. 2004039759
O.P.R.W.C.T.

A CALLED 61.7162 ACRES
COUPLAND INDEPENDENT SCHOOL DISTRICT
INSTRUMENT NO. 2007071605
O.P.R.W.C.T.

A CALLED 179.50 ACRES
BACHMAYER, JOANN E.
INSTRUMENT NO. 191200809
O.P.R.W.C.T.

LINE TABLE		
LINE	DIRECTION	LENGTH
L1	S69°02'30"W	48.76'
L2	N69°04'26"E	53.25'

P.O.B.
GRID COORDINATES
N: 10141362.35
E: 3228975.01
STA: 11+58.76
OFF: 17.25' LT

FIRST TRACT
A CALLED 249.19 ACRES
RAYMOND E. RED AND WIFE,
OLIVERT J. RED
VOL. 443 PG. 681
O.P.R.W.C.T.

SURVWEST PROJECT NO. P240070

ADD'L INFO:

DRAWING NAME: 070 - COUPLAND ISD 61 Acre Tract 20250120

REVISION: 11/25/24 | REV DESC: UPDATED R.O.W.



720.259.9316 6501 E Belleview Ave, Suite 300
www.survwest.com Englewood, CO 80111



MAIN: 281-270-6111
TBPLES FIRM NO: 10194926

1.355 ACRES (59,044 SQ. FT)
SITUATED IN THE JOSEPH JORDAN SURVEY
ABSTRACT NO. 357
WILLIAMSON COUNTY, TEXAS

TITLE: **PROPOSED RIGHT-OF-WAY ACQUISITION EXHIBIT**

DWN:	CHK'D	DATE:	SCALE:	SHEET NO:
KDA	RGM	07/24/2024	1:100	1 OF 2

NOTES

1. BASIS OF BEARING IS BASED ON AN OPUS SOLUTION DATED DECEMBER 5, 2023 AND REFERENCED TO THE TEXAS COORDINATE SYSTEM, NAD83, CENTRAL ZONE (4203). COORDINATES SHOWN HEREON ARE GRID.
2. THIS SURVEY WAS PREPARED WITH THE BENEFIT OF A TITLE COMMITMENT PREPARED BY TEXAN TITLE INSURANCE COMPANY UNDER GF NO. GT2403391 WITH AN EFFECTIVE DATE OF DECEMBER 19, 024.

LEGAL DESCRIPTION

BEING ALL OF A 1.355 ACRE (59,044 SQUARE FEET) TRACT OR PARCEL OF LAND SITUATED IN THE JOSEPH JORDAN SURVEY, ABSTRACT NO. 357, WILLIAMSON COUNTY, TEXAS, AND BEING A PORTION OF A CALLED 61.7162 ACRE TRACT OF LAND DESCRIBED IN THE DEED TO COUPLAND INDEPENDENT SCHOOL DISTRICT, RECORDED IN INSTRUMENT NO. 2007071605, SAID OFFICIAL PUBLIC RECORDS, OF THE OFFICIAL PUBLIC RECORDS, WILLIAMSON COUNTY, TEXAS, AND BEING MORE PARTICULARLY DESCRIBED AS FOLLOWS:

BEGINNING AT A CONCRETE MONUMENT FOUND (GRID COORDINATES N:10141362.35 E: 3228975.01) AT THE SOUTHEAST CORNER OF A CALLED 61.7162 ACRE TRACT OF LAND DESCRIBED IN A DEED TO COUPLAND INDEPENDENT SCHOOL DISTRICT, RECORDED IN DOCUMENT NO. 2007071605 OF THE OFFICIAL PUBLIC RECORDS OF WILLIAMSON COUNTY, TEXAS, SAME BEING THE NORTHWEST CORNER OF A CALLED 249.19 ACRE TRACT OF LAND DESCRIBED AS FIRST TRACT IN A DEED TO RAYMOND E. RED AND WIFE, OLIVERT J. RED, RECORDED IN VOLUME 443, PAGE 681 OF THE DEED RECORDS OF WILLIAMSON COUNTY, TEXAS, IN THE WEST RIGHT-OF-WAY LINE OF COUNTY ROADS 460, 17.25 FEET LEFT OF COUNTY ROAD 460 BASELINE STATION 11+58.76;

THENCE S69°02'30"W, WITH THE SOUTH LINE OF THE 61.7162 ACRE TRACT, SAME BEING THE NORTH LINE OF SAID 249.19 ACRE TRACT, A DISTANCE OF 48.76 FEET TO A CAPPED IRON ROD SET, 65.97 FEET LEFT OF COUNTY ROAD 460 BASELINE STATION 11+60.82;

THENCE N21°52'53"W, CROSSING THROUGH THE 61.7162 ACRE TRACT, A DISTANCE OF 1162.66 FEET TO A CAPPED IRON ROD SET IN THE NORTH LINE OF THE 61.7162 ACRE TRACT, SAME BEING THE SOUTH LINE OF A CALLED 66.183 ACRE TRACT OF LAND DESCRIBED IN A DEED TO UNHAM 1050 FM 1466 COUPLAND TX LLC, RECORDED IN DOCUMENT NO. 2022113522 OF THE OFFICIAL PUBLIC RECORDS OF WILLIAMSON COUNTY, TEXAS, 67.53 FEET LEFT OF COUNTY ROAD 460 BASELINE STATION 23+21.59;

THENCE N69°04'26"E, WITH THE NORTH LINE OF THE 61.7162 ACRE TRACT, SAME BEING THE SOUTH LINE OF SAID 66.183 ACRE TRACT A DISTANCE OF 53.25 FEET TO A 1/2" IRON ROD FOUND AT THE NORTHEAST CORNER OF THE 61.7162 ACRE TRACT, SAME BEING THE SOUTHEAST CORNER OF THE 66.183 ACRE TRACT, AND BEING IN THE WEST RIGHT-OF-LINE OF COUNTY ROAD 460, 14.29 FEET LEFT OF COUNTY ROAD 460 BASELINE 23+20.91;

THENCE WITH THE EAST LINE OF THE 61.7162 ACRE TRACT, SAME BEING THE WEST RIGHT-OF-WAY LINE OF COUNTY ROAD 460 THE FOLLOWING TWO (2) COURSES AND DISTANCES:

1. S21°35'57"E A DISTANCE OF 400.06 FEET TO A 1/2" IRON ROD FOUND, 14.67 FEET LEFT OF COUNTY ROAD 460 BASELINE STATION: 19+20.81;
2. S21°41'32"E A DISTANCE OF 762.51 FEET TO THE POINT OF BEGINNING AND CONTAINING 1.355 ACRES (59,044 SQ. FEET) OF LAND, MORE OR LESS.

LEGEND

- FOUND MONUMENT
- FOUND CONC MON
- 5/8" CAPPED IRON ROD SET
- P.O.B. POINT OF BEGINNING
- P.O.C. POINT OF COMMENCING
- R.O.W. RIGHT OF WAY
- IRF IRON ROD FOUND
- CIRS CAPPED IRON ROD SET
- CIRF CAPPED IRON ROD FOUND
- PROPERTY BOUNDARY
- ADJOINER LINE
- BARBED WIRE FENCE
- O.P.R.W.C.T. OFFICIAL PUBLIC RECORDS WILLIAMSON COUNTY, TEXAS
- D.W.C.T. DEED RECORDS WILLIAMSON COUNTY, TEXAS

I CERTIFY THAT THIS SURVEY WAS MADE ON THE GROUND, THAT THIS PLAT CORRECTLY REPRESENTS THE FACTS FOUND AT THE TIME OF SURVEY AND THAT THIS PROFESSIONAL SERVICE SUBSTANTIALLY CONFORMS TO TEXAS BOARD OF PROFESSIONAL ENGINEERS AND LAND SURVEYORS STANDARDS AND SPECIFICATIONS. PROJECT CONTROLS WERE ESTABLISHED UNDER THE DIRECTION OF SURVWEST AND VERIFIED BY WLG SURVEYING SOLUTIONS, LLC. THE MONUMENTS WERE SET AND TIES ARE BASED ON AN ON THE GROUND SURVEY PERFORMED UNDER THE DIRECT SUPERVISION OF A PREVIOUS RPLS AND WERE REVIEWED AND VERIFIED BY TRISHA MYREE LUND, R.P.L.S. # 6088.

Trisha Lund

TRISHA MYREE LUND
REGISTERED PROFESSIONAL LAND SURVEYOR
TEXAS REGISTRATION NO. 6088

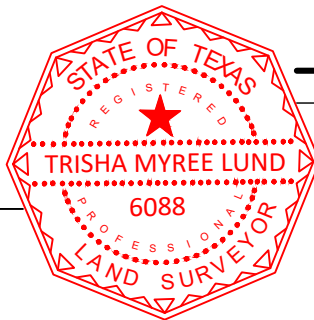

SURVWEST PROJECT NO. P240070

ADD'L INFO:

DRAWING NAME: P240070 - COUPLAND ISD 61 Acre Tract 20250120

REVISION: 1/29/25 REV DESC: COMMENTS & TC

720.259.9316
www.survwest.com

720.259.9316
6501 E Belleview Ave, Suite 300
Englewood, CO 80111

MAIN: 281-270-6111
TBPLES FIRM NO:
10194926

1.355 ACRES (59,044 SQ. FT)
SITUATED IN THE JOSEPH JORDAN SURVEY
ABSTRACT NO. 357
WILLIAMSON COUNTY, TEXAS

TITLE: **PROPOSED RIGHT-OF-WAY ACQUISITION EXHIBIT**

DWN:	CHK'D	DATE:	SCALE:	SHEET NO:
KDA	RGM	07/24/2024	1:100	2 OF 2

TO HAVE AND TO HOLD the property herein described and herein conveyed together with all and singular the rights and appurtenances thereto in any wise belonging unto County and its assigns forever; and Grantor does hereby bind itself, its heirs, executors, administrators, successors, and assigns to Warrant and Forever Defend all and singular the said premises herein conveyed unto County and its assigns against every person whomsoever lawfully claiming or to claim the same or any part thereof, by through or under Grantor, but not otherwise except as to the Reservations from and Exceptions to Conveyance and Warranty.

IN WITNESS WHEREOF, this instrument is executed on this the _____ day of _____, 2025

GRANTOR:

COUPLAND INDEPENDENT SCHOOL DISTRICT

By: _____

Printed Name: _____

Title: _____

ACKNOWLEDGMENT

STATE OF TEXAS

§

COUNTY OF WILLIAMSON

§

§

This instrument was acknowledged before me on _____, 2025 by _____, in the capacity and for the purposes and consideration recited therein.

(seal)

Notary Public, State of Texas

ACCEPTED AND ACKNOWLEDGED:

WILLIAMSON COUNTY, TEXAS

By: _____

Name: _____
County Judge/Presiding Officer

ACKNOWLEDGMENT

STATE OF TEXAS §

§

COUNTY OF WILLIAMSON §

This instrument was acknowledged before me on _____,
2025 by _____, in the capacity and for the purposes and
consideration recited therein.

Notary Public, State of Texas

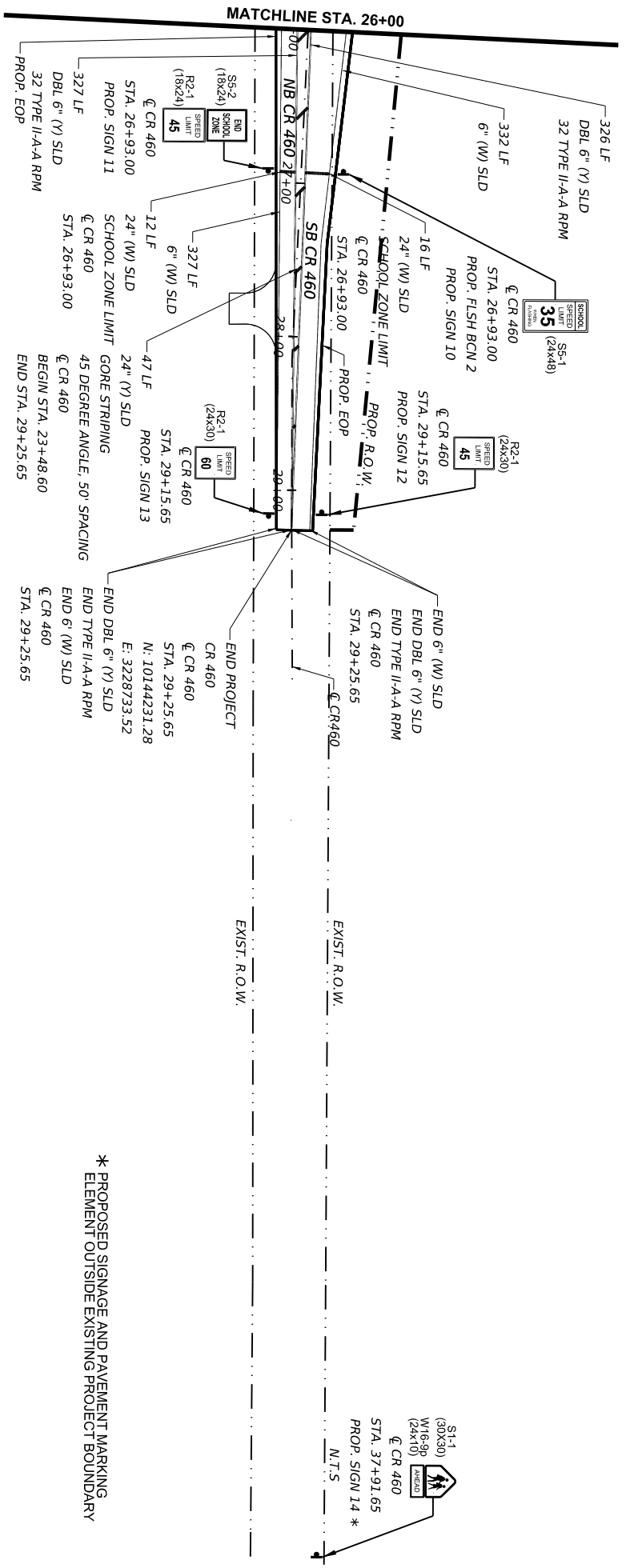

* PROPOSED SIGNAGE AND PAVEMENT MARKING
ELEMENT OUTSIDE EXISTING PROJECT BOUNDARY

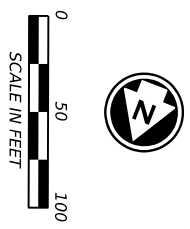

3/21/2025

REV	DATE	DESCRIPTION	APPROVED

DESIGN	GRAPHICS	CHECK	CHECK	SHEET NO.
JC	JC	MP		
PRESENT	COUNTY			
PCT 4	WILLIAMSON			

2025	SHEET 2 OF 2		

CR 460
SIGNING AND
PAVEMENT MARKING
LAYOUT
(STA. 26+00 TO END)















FIRM REGISTRATION No. F-10161

SUMMARY OF SMALL SIGNS

DATE:
FILE:

DISCLAIMER:
The use of this standard is governed by the "Texas Engineering Practice Act". No warranty of any kind is made by TxDOT for any purpose whatsoever. TxDOT assumes no responsibility for the conversion of this standard to other formats or for incorrect results or damages resulting from its use.

PLAN SHEET NO.	SIGN NO.	SIGN NOMENCLATURE	SIGN	DIMENSIONS	FLAT ALUMINUM (TYPE A)	EXAL ALUMINUM (TYPE C)	SM RD SGN ASSM TY XXXXX (X) XX (X-XXXX)				BRIDGE MOUNT CLEARANCE SIGNS (See Note 2)	
							POST TYPE	POSTS	ANCHOR TYPE	MOUNTING DESIGNATION		
1	1	S1-1 W16-9D		30X30 24X10	X		10BWG	1	SA	P		
1	2	R2-1		24X30	X		10BWG	1	SA	P		
1	3	R2-1		24X30	X		10BWG	1	SA	P		
1	4	SS-2 R2-1		18X24 18X24	X		10BWG	1	SA	P		
1	5	SS-1		24X48	X		INSTALLED ON FLASHING BEACON					
1	6	R1-1		36X36	X		10BWG	1	SA	P		
1	7	R3-7R		30X30	X		10BWG	1	SA	P		
1	8	R1-1		36X36	X		10BWG	1	SA	P		
1	9	R3-7R		30X30	X		10BWG	1	SA	P		
2	10	SS-1		24X48	X		INSTALLED ON FLASHING BEACON					
2	11	SS-2 R2-1		18X24 18X24	X		10BWG	1	SA	P		
2	12	R2-1		24X30	X		10BWG	1	SA	P		

ALUMINUM SIGN BLANKS THICKNESS	
Square Feet	Minimum Thickness
Less than 7.5	0.080"
7.5 to 15	0.100"
Greater than 15	0.125"

The Standard Highway Sign Designs for Texas (SHSD) can be found at the following website:
<http://www.txdot.gov/>

NOTE:

1. Sign supports shall be located as shown on the plans, except that the Engineer may shift the sign supports, within design guidelines, where necessary to secure a more desirable location or to avoid conflict with utilities. Unless otherwise shown on the plans, the Contractor shall stake and the Engineer will verify all sign support locations.
2. For installation of bridge mount clearance signs, see Bridge Mounted Clearance Sign Assembly (BMC) Standard Sheet.
3. For Sign Support Descriptive Codes, see Sign Mounting Details Small Roadside Signs General Notes & Details SMD (GEN).



SUMMARY OF SMALL SIGNS

SOSS

Files	sums16.dgn	DN: JC	CK: MP	DM: JC	CK: MP
Files	TxDOT	REV: JC	REV: JC	REV: JC	REV: JC
Files	1987	REV: JC	REV: JC	REV: JC	REV: JC
Files	4-16	REV: JC	REV: JC	REV: JC	REV: JC
Files	8-16	REV: JC	REV: JC	REV: JC	REV: JC

GENERAL NOTES:

1. Details show a typical warning sign with two flashing beacon heads, other arrangements are possible. When only one beacon is required, install the upper beacon.
2. See Item 685, "Roadside Flashing Beacon Assemblies" for further requirements.
3. See SMD standard sheets for lateral and vertical clearances and sign mounting details. Install signs as shown on the sign layout sheets.
4. Use either a Screw-In Type Anchor Foundation or a Drilled Shaft Foundation as shown elsewhere in the plans. When plans require a Drilled Shaft Foundation, see standard sheet TS-FD. Install the Screw-In Type Anchor Foundation as per manufacturer's recommendations. On a slope, install one edge at ground level. Screw-In/Drilled Shaft Foundation is subsidiary to Item 685. Installation of a ground rod is not required for solar powered flashing beacon assemblies.
5. When used, provide Screw-In Type Anchor Foundations as shown on TxDOT's Material Producer List (MPL) in the file "Highway Traffic Signals".
6. Use materials specifically designed for attaching cabinets, beacon heads, solar panels, etc., to poles.
7. Install beacon heads as shown here, as shown elsewhere on the plans, or as directed. Use hardware specifically designed for mounting beacon heads on poles.
8. Conduit in foundation and within 6 in. of foundation is subsidiary to the Item 685, "Roadside Flashing Beacon Assemblies."
9. Per manufacturer's recommendations, engage all threads on the pedestal pole base and pipe unless the pipe is fully seated into base. In high winds, use a pole and base collar assembly to add strength and prevent loosening on connection.
10. Provide single pole non-fused watertight breakaway electrical connectors for frangible pedestal pole bases, as shown on TxDOT's MPL in the file "Roadway Illumination and Electrical Supplies." Approved models are listed under Item 685. For ungrounded (hot) conductors, install a breakaway connector with a dummy fuse slug. For grounded (neutral) conductors, install a breakaway connector with a white colored marking and a permanently installed dummy fuse (slug).
11. Install the batteries in a battery box. Place the batteries on a $\frac{3}{16}$ " thick plastic sheet and connect together. Place a plastic cover (battery bell jar) over the top of each battery and secure the battery bell jar to the battery with a strap. The batteries, bell jars, straps and $\frac{3}{16}$ " plastic sheet are subsidiary to the Item 685, "Roadside Flashing Beacon Assemblies." When required, install batteries in the flasher cabinet. Wire batteries according to manufacturer's recommendations. Provide the number of batteries as required by the manufacturer.
12. See standard sheet Electrical Details (ED) for additional requirements regarding the installation of ground boxes/battery boxes, conduit, and cabinets.
13. Provide clearance as shown above the sidewalk or pavement grade at the edge of the road. When a bottom beacon is not used, mount the bottom of the sign at least 7 ft. above the sidewalk or pavement grade at the edge of the road.
14. Unless otherwise shown on the plans, pole shaft shall be one piece, Schedule 40 Aluminum pipe, ASTM B429 or B221 (Alloy 6061-T6 only). Aluminum conduit will not develop the necessary strength and will not be allowed.
15. Orient solar panel for optimum exposure to sunlight (face to the south). Prior to installation, check the location to ensure there is no overhead obstruction that would block the solar panel from receiving full sunlight. Unless specified elsewhere, mount a minimum of 14' above grade.
16. Ensure height of conduit is below top of anchor bolts.

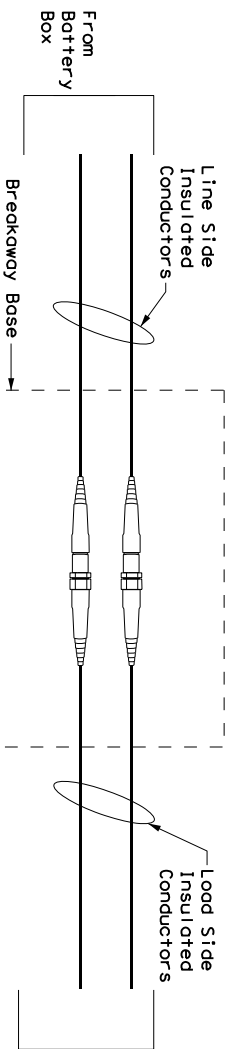

NON-FUSED BREAKAWAY ELECTRICAL CONNECTORS

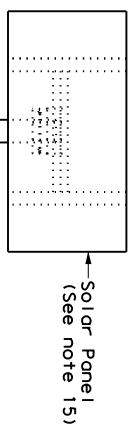

SIGN (See Note 3)

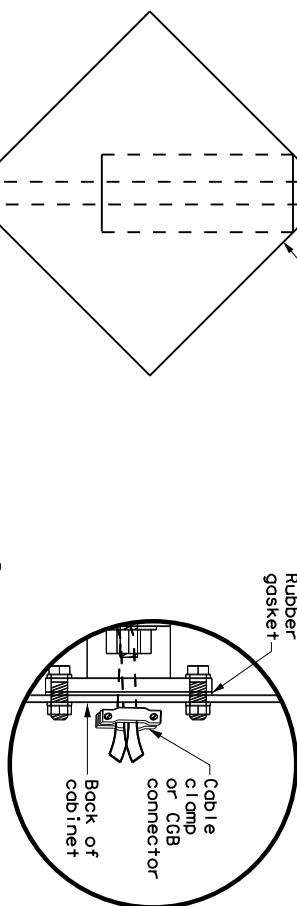

Pull conductors to remove slack in cable or conduit end in ground box and in cabinet of entry as shown.

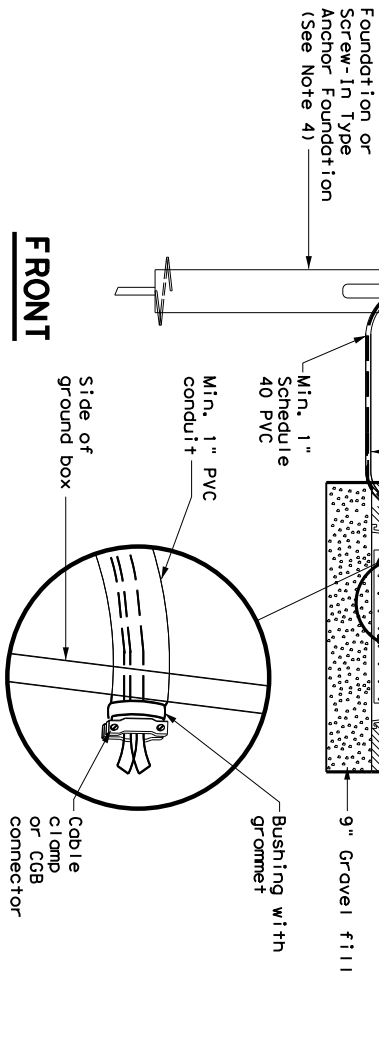
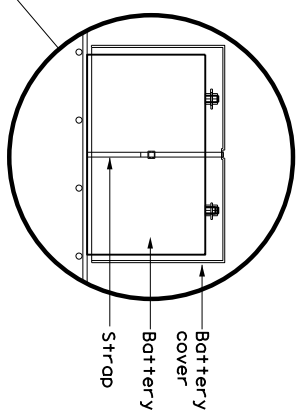

FRONT

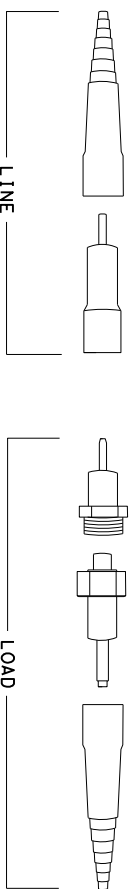

NON-FUSED BREAKAWAY ELECTRICAL CONNECTORS EXPLODED VIEW

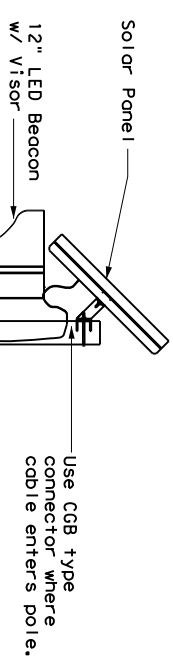

Drill pole for wire entry, remove any burrs or rough edges that may cause damage to conductors.

Drill pole for wire entry, remove any burrs or rough edges that may cause damage to conductors.

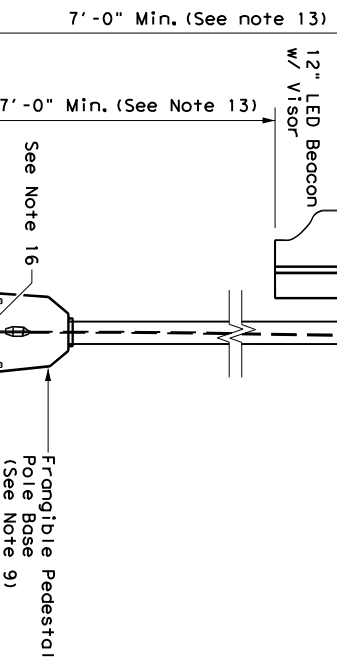

SIDE

SOLAR POWERED ROADSIDE FLASHING BEACON ASSEMBLY DETAILS

SPRFBA(1) - 13

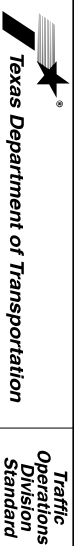

DATE:
FILE:

DISCLAIMER:

The use of this standard is governed by the "Texas Engineering Practice Act". No warranty of any kind is made by TxDOT for any purpose whatsoever. TxDOT assumes no responsibility for the conversion of this standard to other formats or for incorrect results or damages resulting from its use.

FILE#	SDD1-13.dgn	DN:	TxDOT	CK:	TxDOT	DM:	TxDOT	CR:	TxDOT
REV#	1	DATE	12-04	BY	3-13	APP		COUNTY	
<p>12-04 3-13</p>									

**COUPLAND INDEPENDENT SCHOOL DISTRICT BOARD OF TRUSTEES
RESOLUTION AUTHORIZING THE DONATION OF THE RIGHT-OF-WAY TO
WILLIAMSON COUNTY FOR PURPOSES CONSTRUCTING A ROAD**

WHEREAS, pursuant to Texas Education Code section 11.154, the Board of Trustees of the Coupland Independent School District (“District”) is authorized to convey real and personal property;

WHEREAS, the District owns a tract of land described as a 61.7162 acre tract of land described in the deed to Coupland Independent School District, recorded in instrument No. 2007071605, said official public records of Williamson County, Texas (“Property”);

WHEREAS, Williamson County (“County”) is constructing a road part of the County’s 2023 Bond Program CR 460, and part of this road is located on the Property;

WHEREAS, the County is requesting from the District a donation of land to construction the road, specifically a donation of 1.355 acres (59,077 square feet) tract of the Property, more specifically described in **Exhibit A** attached and incorporated to this resolution (“Donation Tract”);

WHEREAS, in exchange for the Donation Tract, the County agrees to at its sole cost to cause additional traffic control and signalization improvements within the Parcel and other property owned or acquired by County to be constructed as part of its proposed 2023 Bond Program CR 460 roadway improvement project (the “School Traffic Control Improvements”), as stated in the agreement for donation of real property between the District and County (the “Agreement”);

WHEREAS, the Board of Trustees has determined that the conveyance of the Donation Tract to the County will benefit the District in the form of an improved road and traffic control improvements and serves a legitimate public and educational purpose providing an improved road and safety to its students;

WHEREAS, the Board of Trustees has determined that the District will receive value in the form of an improved road and traffic control for the District; and

WHEREAS, reasonably adequate controls are in place to ensure that such benefits are received by the District, since the Agreement sets out the services to be provided for the further support of the District.

NOW THEREFORE BE IT RESOLVED,

1. That the findings and recitals in the preamble of this Resolution are hereby found to be true and correct and are hereby approved and adopted.
2. That the Board of Trustees authorizes the Board President and the Superintendent to continue negotiating the Agreement and the Donation Deed with the County, and further

authorizes the Board President to execute the Agreement and the Deed in a form approved by legal counsel.

3. That it is hereby found, determined and declared that a sufficient written notice of the date, time, place and subject of the meeting of the Board of Trustees of the Coupland Independent School District at which this Resolution was adopted was posted at a place convenient and readily accessible at all times to the general public for the time required by law preceding this meeting as required by Chapter 551, Texas Government Code, and that this meeting has been open to the public as required by law at all times during which this Resolution and the subject matter thereof has been discussed, considered and formally acted upon. The Board of Trustees further ratifies, approves and confirms such written notice and posting thereof.

FINALLY PASSED AND ADOPTED this ____ day of April, 2025.

By: _____
Ms. Crystal Ward, President
Board of Trustees of the Coupland Independent
School District

ATTEST:

Mr. David Young, Secretary
Board of Trustees of the Coupland
Independent School District

CERTIFICATE FOR RESOLUTION

I hereby certify that the foregoing Resolution was presented to the Board of Trustees of the Coupland Independent School District during a properly scheduled meeting on April _____, 2025. A quorum of the Board of Trustees being then present, it was then duly moved and seconded that the Resolution be adopted, and such Resolution was then adopted according to the following vote:

Ayes: _____
Noes: _____
Abstentions: _____

To certify which, witness my hand on the _____ day of April, 2025.

By: _____
Mr. David Young, Secretary
Board of Trustees of the Coupland Independent
School District

THE STATE OF TEXAS

§
§
§

ACKNOWLEDGEMENT

COUNTY OF WILLIAMSON

BEFORE ME, a Notary Public, appeared Ms. Crystal Ward, and having been sworn, upon her oath stated that she is the President of the Board of Trustees of the Coupland Independent School District; that she was authorized to execute such instrument pursuant to Resolution of the Board of Trustees adopted on _____, 2025; and that said instrument is executed as the free and voluntary act and deed of such governmental unit for the purposes expressed therein.

GIVEN UNDER MY HAND AND SEAL OF OFFICE on this the _____ day of _____, 2025.

Notary Public, State of Texas

EXHIBIT A
PROPOSED RIGHT OF WAY

EXHIBIT B
DONATION DEED

Note: For legal requirements applicable to the disposition of real property acquired with federal funds, see CBB.

Sale or Exchange of Real Property

The board may, by resolution, authorize the sale of any property, other than minerals, held in trust for public school purposes. The board president shall execute a deed to the purchaser reciting the board resolution authorizing the sale. A district may employ, retain, contract with, or compensate a licensed real estate broker or salesperson for assistance in the acquisition or sale of real property. *Education Code 11.154*

Publication of Notice and Bidding Requirements

Except for the types of land and interests described at Exceptions, below, before land owned by a district may be sold or exchanged for other land, notice to the general public of the offer of the land for sale or exchange must be published in a newspaper of general circulation in either the county in which the land is located or, if there is no such newspaper, in an adjoining county. The notice must include a description of the land, including its location, and the procedure by which sealed bids to purchase the land or offers to exchange the land may be submitted. The notice must be published on two separate dates and the sale or exchange may not be made until after the 14th day after the date of the second publication. Local Government Code 272.001 does not require the board to accept any bid or offer or to complete a sale or exchange. *Local Gov't Code 272.001(a), (d)*

Open-Enrollment Charter School Offer

The board of a district that intends to sell, lease, or allow use for a purpose other than a district purpose of an unused or underused district facility must give each open-enrollment charter school located wholly or partly within the boundaries of the district the opportunity to make an offer to purchase, lease, or use the facility, as applicable, in response to any terms established by the board, before offering the facility for sale or lease or to any other specific entity. The board is not required to accept an offer made by an open-enrollment charter school. *Education Code 11.1542*

Exceptions
Generally

The notice and bidding requirements set out above do not apply to the types of land and real property interests described below and owned by a district. The land and those interests described below may not be conveyed, sold, or exchanged for less than the fair market value of the land or interest unless the conveyance, sale, or exchange is with one or more abutting property owners who own the underlying fee simple. The fair market value is determined by an appraisal obtained by the district that owns the land or interest. The appraisal price is conclusive of the fair market value of the land or interest. This applies to:

OTHER REVENUES
SALE, LEASE, OR EXCHANGE OF SCHOOL-OWNED PROPERTY

CDB
(LEGAL)

1. Narrow strips of land, or land that because of its shape, lack of access to public roads, or small area cannot be used independently under its current zoning or under applicable subdivision or other development control ordinances;
2. Streets or alleys, owned in fee or used by easement;
3. Land or a real property interest originally acquired for streets, rights-of-way, or easements that the district chooses to exchange for other land to be used for streets, rights-of-way, easements, or other public purposes, including transactions partly for cash;
4. Land that the district wants to have developed by contract with an independent foundation;
5. A real property interest conveyed to a governmental entity that has the power of eminent domain; or
6. The land or interests described by items 1 and 2, above, may be sold to abutting property owners:
 - a. In the same subdivision if the land has been subdivided; or
 - b. In proportion to their abutting ownership, and the division between owners must be made in an equitable manner.

Local Gov't Code 272.001(b)-(c)

*Higher Education
Institutions*

A district may donate, exchange, convey, sell, or lease land, improvements, or any other interest in real property to an institution of higher education for less than its fair market value and without complying with the notice and bidding requirements in order to promote a public purpose related to higher education. The district shall determine the terms and conditions of the transaction so as to effectuate and maintain the public purpose. *Local Gov't Code 272.001(j)*

*Other Political
Subdivisions*

A district may donate or sell for less than fair market value and without complying with the notice and bidding requirements a designated parcel of land or an interest in real property to another political subdivision if:

1. The land or interest will be used by the political subdivision to which it is donated or sold in carrying out a purpose that benefits the public interest of the donating or selling district;
2. The donation or sale of the land or interest is made under terms that effect and maintain the public purpose for which the donation or sale is made; and

OTHER REVENUES
SALE, LEASE, OR EXCHANGE OF SCHOOL-OWNED PROPERTY

CDB
(LEGAL)

3. The title and right to possession of the land or interest revert to the donating or selling district if the acquiring political subdivision ceases to use the land or interest in carrying out the public purpose.

Local Gov't Code 272.001(l)

Sale of Instructional Facility Financed with State Allotment

If an instructional facility financed by bonds paid with state and local funds under Education Code Chapter 46, Subchapter A, is sold before the bonds are fully paid, a district shall send to the comptroller a percentage of the district's net proceeds as determined by Education Code 46.011(a). *Education Code 46.011* [See also CCA]

Lease of Public Property

To a Governmental Entity

To promote a public purpose of the district, a district may:

1. Lease property owned by the district to another political subdivision or an agency of the state or federal government; or
2. Make an agreement to provide office space in property owned by the district to the other political subdivision or agency.

The district:

1. Shall determine the terms of the lease or agreement so as to promote and maintain the public purpose;
2. May provide for the lease of the property or provision of the office space at less than fair market value; and
3. Is not required to comply with any competitive purchasing procedure or any notice and publication requirement imposed by Local Government Code Chapter 272 or other law.

Local Gov't Code 272.005

Required Terms for All Leases

Payment and Performance Bonds

A lease between a district and another person regarding public property must contain lease terms requiring the person to:

1. Include in each contract for the construction, alteration, or repair of an improvement to the leased property a condition that the contractor:
 - a. Execute a payment bond that conforms to Property Code Chapter 53, Subchapter I (Bond to Pay Lien or Claims); and
 - b. Execute a performance bond in an amount equal to the amount of the contract for the protection of the district and conditioned on the faithful performance of the contractor's work in accordance with the plans, specifications, and contract documents; and

OTHER REVENUES
SALE, LEASE, OR EXCHANGE OF SCHOOL-OWNED PROPERTY

CDB
(LEGAL)

2. Provide to the district a notice of commencement at least 90 days before the date the construction, alteration, or repair of any improvement to the leased property begins.

*Notice of
Commencement*

A notice of commencement must:

1. Identify the public property where the work will be performed;
2. Describe the work to be performed;
3. State the total cost of the work to be performed;
4. Include copies of the required performance and payment bonds; and
5. Include a written acknowledgment signed by the contractor stating that copies of the required performance and payment bonds will be provided to all subcontractors not later than the fifth day after the date a subcontract is executed.

On or before the 10th day after the date a district receives a notice of commencement for the construction, alteration, or repair of an improvement to leased property, the district may notify the leaseholder that the construction, alteration, or repair may not proceed.

Gov't Code 2252.909(b), (c), (d)

A district is not liable as a surety if a person leasing property from the district fails to submit the required notice of commencement.

Gov't Code 2253.027(c)

**Sale or Lease of
Minerals**

Minerals in land belonging to a district may be sold to any person. The sale must be authorized by a resolution adopted by majority vote of the board. *Education Code 11.153(a)-(b)*

After the board determines that it is advisable to lease land belonging to the district, it shall give notice of its intention to lease the land. The notice shall be published once a week for three consecutive weeks in a newspaper published in the county and with general circulation in the county, and shall:

1. Describe the land to be leased; and
2. Designate the time and place at which the board will receive and consider bids for the lease.

Natural Resources Code 71.005

After adoption of a resolution authorizing sale, the board president may execute an oil or gas lease or sell, exchange, and convey the minerals. The mineral deed or lease must recite the approval of the resolution of the board authorizing the sale. *Education Code 11.153(c)*

**Donation of Former
School Campus**

The board may, by resolution, authorize the donation of real property and improvements formerly used as a school campus to a municipality, county, state agency, or nonprofit organization if:

1. Before adopting the resolution, the board holds a public hearing concerning the donation and, in addition to any other notice required, gives notice of the hearing by publishing the subject matter, location, date, and time of the hearing in a newspaper having general circulation in the territory of a district;
2. The board determines that:
 - a. The improvements have historical significance;
 - b. The transfer will further the preservation of the improvements; and
 - c. At the time of the transfer, the district does not need the real property or improvements for educational purposes; and
3. The entity to whom the transfer is made has shown, to the satisfaction of the board, that the entity intends to continue to use the real property and improvements for public purposes.

The board president shall execute a deed transferring ownership of the real property and improvements to the municipality, county, state agency, or nonprofit organization. The deed must:

1. Recite the resolution of a board authorizing the donation; and
2. Provide that ownership of the real property and improvements revert to a district if the municipality, county, state agency, or nonprofit organization:
 - a. Discontinues use of the real property and improvements for public purposes; or
 - b. Executes a document that purports to convey the property.

Education Code 11.1541(a)-(b)

Note: Regarding disposal of school buses, see CNB.
Regarding disposal of school-owned personal property, see CI.
Regarding geospatial data products, see CQA.

Educ. Code Section 11.1541

Donation of Surplus Property

- (a) The board of trustees of an independent school district may, by resolution, authorize the donation of real property and improvements formerly used as a school campus to a municipality, county, state agency, or nonprofit organization if:
- (1) before adopting the resolution, the board holds a public hearing concerning the donation and, in addition to any other notice required, gives notice of the hearing by publishing the subject matter, location, date, and time of the hearing in a newspaper having general circulation in the territory of the district;
 - (2) the board determines that:
 - (A) the improvements have historical significance;
 - (B) the transfer will further the preservation of the improvements; **and**
 - (C) at the time of the transfer, the district does not need the real property or improvements for educational purposes; **and**
 - (3) the entity to whom the transfer is made has shown, to the satisfaction of the board, that the entity intends to continue to use the real property and improvements for public purposes.
- (b) The president of the board of trustees shall execute a deed transferring ownership of the real property and improvements to the municipality, county, state agency, or nonprofit organization. The deed must:
- (1) recite the resolution of the board authorizing the donation; **and**
 - (2) provide that ownership of the real property and improvements revert to the district if the municipality, county, state agency, or nonprofit organization:

A)

discontinues use of the real property and improvements for public purposes; **or**

(B)

executes a document that purports to convey the property.

(c)

In this section, "nonprofit organization" means an organization exempt from federal income taxation under Section 501(a), Internal Revenue Code of 1986, as an organization described by Section 501(c)(3) of that code. Added by Acts 2001, 77th Leg., ch. 161, Sec. 1, eff. Jan. 1, 2002. Amended by Acts 2003, 78th Leg., ch. 1189, Sec. 1, eff. Sept. 1, 2003.

Source: Section 11.1541 — *Donation of Surplus Property*, <https://statutes.capitol.texas.gov/Docs/ED/htm/ED-11.htm#11.1541> (accessed Feb. 26, 2025).



Board of Trustees

Date of Meeting
Item Type

Item Name	
District Goal	
Summary (Purpose / Objective)	
Fiscal Impact	
Administrative Recommendation	

Attachments	
-------------	--

Contact Person E-Mail Address

STATEMENT OF WORK #5
SUBJECT TO AND PROVIDED UNDER THE MASTER SERVICES AGREEMENT
BETWEEN The Coupland ISD AND SERVICE PROVIDER DATED 4.23.25

A. PROJECT NAME:

The Coupland ISD Technology Support Retainer

B. SERVICES PROVIDED FOR:

The Coupland ISD

C. LOCATION OF WORK:

The Coupland ISD and remote support

D. BACKGROUND:

The Coupland ISD would like strategic planning and support for its technology program. This includes regular meetings with The Coupland ISD staff, as well as email and phone support.

E. Scope of Work:

Service Provider will provide the following:

1. Capacity Building: Advising and support of existing district technology personnel.
2. Strategic Planning: Develop detailed long range strategic plan.
3. Tactical Planning: Develop actionable roadmap for one, three, and five years.
4. Digital Review: Review of technology products, services, and initiatives

Out of scope engagements include, but not limited to extensive engineering activity and extended on-site work in CISD. These engagements must be approved in writing by the superintendent or designee.

F. DUTIES:

The Service Provider will report directly to the Director and to any other party designated by the Director in connection with the performance of the duties under this Agreement and shall fulfill any other duties reasonably requested by Superintendent.

G. SPECIAL REQUIREMENTS / SUPPORT REQUESTED BY SERVICE PROVIDER

Full Cooperation of The Coupland ISD Staff.

H. TERM / PERIOD OF PERFORMANCE:

- I.** This engagement shall commence on August 1, 2025 – July 31, 2026. Either party can terminate this agreement with 30 days written notice. This SOW supersedes all former or current agreements.

J. COMPENSATION / PAYMENT SCHEDULE:

As compensation for the services rendered pursuant to this SOW, The Coupland ISD shall pay Service Provider \$2,500 per month, for a total of \$30,000, which includes all travel and usual expenses.

Renaissance Institute, Inc.

The Coupland ISD

By: _____
Its: President

By: _____
Its:

Dr. Andrew Berning
Date:

Date:



Board of Trustees

Date of Meeting

Item Type

Item Name	
District Goal	
Summary (Purpose / Objective)	
Fiscal Impact	
Administrative Recommendation	

Attachments	
-------------	--

Contact Person

E-Mail Address



DURAN & ASSOCIATES

STEPHANIE DURAN CPA, RTSBA | 832.693.1214 | stephanie@duranassoc.com

April 30, 2025

To the Board of Trustees and Management
Coupland Independent School District
620 South Commerce Street
Coupland, Texas 78615

We are pleased to confirm our understanding of the services we are to provide for Coupland Independent School District (the “District”). We will perform an efficiency audit as required by House Bill 3, 86th Legislature, 2019, and as prescribed by the State of Texas Legislative Budget Board.

Efficiency Audit Objectives, Scope, and Methodology

The objective of our efficiency audit is to assess the District’s fiscal management, efficiency, utilization of resources, and whether the District has implemented best practices utilized by other Texas school districts. We will conduct our efficiency audit in accordance with the standards for performance audits contained in Government Auditing Standards, issued by the Comptroller General of the United States, and will include tests of the District’s records and other procedures we consider necessary to complete the efficiency audit. We will plan and conduct the efficiency audit to obtain reasonable rather than absolute assurance about the District’s fiscal management, efficiency, and utilization of resources in comparison to its peer districts.

Our methodology in performing our audit will include review of certain documentation and inquiries based on the most recent school year for which data are available. At the end of our audit, we will provide summary of the results of our procedures as described below:

- The date of the election to adopt the District’s M&O tax rate;
- The dates of the previous three tax ratification elections, the tax rate increase proposed by each, and the results of the elections;
- Current M&O tax rate and the proposed tax rate compared to peer districts and the state average;
- The amount of tax revenue the tax rate change is estimated to generate in the first school year in dollars and as a percentage of the District’s current operating budget;
- The Estimated dollar-amount increase, as a result of the M&O tax rate change, to the property tax bill of a single-family residential property at the current average home value of the District;



- A District statement explaining how it intends to spend the additional tax revenue, including any new programs, and consequences if the measure does not pass;
- District has:
 - adopted SMART student outcome goals;
 - implemented and approved, high-quality, teacher incentive pay program; and
 - adopted a student-based, weighted funding system so the money follows the student to their school based on the student's needs;
- The District's and the Campuses' accountability rating compared to peer districts;
- The District's School Financial Integrity Rating System of Texas (FIRST) rating;
- The District's actual operating expenditures per enrolled student compared to peer districts and the state average;
- A high-level summary of any significant findings of the efficiency audit, and any District responses to the findings.

In order to provide the summary items listed above, we must perform and report on the following 20 steps:

1. Five (5) to ten (10) peer districts will be selected to develop a simple average and we will use the same comparison group throughout the audit.
2. Include the overall accountability rating (A-to-F and a corresponding scale score of 1 to 100) and compare the District's peer districts' average score. We will also list the following District's campus information:
 - a. Accountability rating count for each campus level within the District.
 - b. Names of the campuses that received an F accountability rating
 - c. Campuses that are required to implement a campus turnaround plan
3. Report on the District's School FIRST rating. For a rating of less than A-, we will list the indicators not met.
4. We will report on the District's student characteristics, attendance rates and total enrollment.
 - a. The following select student characteristics for the District, its peer districts, and the State average.
 - Total students
 - Economically disadvantaged
 - English Learners
 - Special Education
 - Bilingual/ESL Education
 - Career and Technical Education
 - b. Attendance rate for the District, its peer districts, and the State.
 - c. Five-year enrollment for the District for the most recent school year and four (4) years prior, the average annual percentage change based on the previous five years and the projected next school year.

5. The following indicators related to the District's revenue, its peer districts' average, and the State average.
 - a. Local M& O Tax (Retained) (without debt service and recapture)
 - b. State
 - c. Federal
 - d. Other local and intermediate
 - e. Total revenue

Any significant variances will be explained.

6. The following indicators related to the District's expenditures, its peer districts' average, and the State average are as follows:
 - a. Instruction
 - b. Instructional resources and media
 - c. Curriculum and staff development
 - d. Instructional leadership
 - e. School leadership
 - f. Guidance counseling services
 - g. Social work services
 - h. Health services
 - i. Transportation
 - j. Food service operation
 - k. Extracurricular
 - l. General administration
 - m. Plant maintenance and operations
 - n. Security and monitoring services
 - o. Data processing services
 - p. Community services
 - q. Total operating expenditures

An explanation for significant variances from the peer districts' average in any category will be reported. In addition, the reasons for the District's expenditures exceeding revenue will be explained.

7. We will report on the following indicators for payroll and select salary District expenditures compared to its peer districts' average and the State average:
 - a. Payroll as a percentage of all funds
 - b. Average teacher salary
 - c. Average administrative salary
 - d. Superintendent salary

Specific information to explain any significant variance from the peer districts' average in any category will be explained.

8. Report on the General Fund operating fund balance, excluding debt service and capital outlay, for the past five years and per student. This will include analyzing unassigned balance per student and as a percentage of three-month operating expenditures. This will be presented for peer districts as well and an explanation for significant variances.

9. Report the District's allocation of staff, and student-to-teacher and student-to-total staff ratios for the District, its peer districts, and the State average. The following staff categories will be used:
 - a. Teaching
 - b. Support
 - c. Administrative
 - d. Paraprofessional
 - e. Auxiliary
 - f. Students per total staff
 - g. Students per teaching staff
10. Report the District's teacher turnover rate as well as its peer districts and the State's average.
11. For each of the following programs offered by the District, we will report the number of students served, percentage of enrolled students served, program budget, program budget as a percentage of the District's budget, total staff or the program, and student-to-staff ratio for the program.
 - a. Special Education
 - b. Bilingual Education
 - c. Migrant Programs
 - d. Gifted and Talented Programs
 - e. Career and Technical Education
 - f. Athletics and Extracurricular Activities
 - g. Alternative Education Program/Disciplinary Alternative Education Program
 - h. Juvenile Justice Alternative Education Program
12. We will describe how the District maximizes available resources from state sources and regional education service centers to develop or implement programs or deliver services.
13. We will report on the District's annual external audit report's independent auditor's opinion as required by Government Auditing Standards.
14. If applicable, explain the basis of TEA assigning the District a financial-related monitoring/oversight role during the past three years.
15. In regard to the District's budget process, we will provide a response to each of the following questions:
 - a. Does the District's budget planning process include projections for enrollment and staffing?
 - b. Does the District's budget process include monthly and quarterly reviews to determine the status of annual spending?
 - c. Does the District use cost allocation procedures to determine campus budgets and cost centers?
 - d. Does the District analyze educational costs and student needs to determine campus budgets?
16. We will provide a description of the District's self-funded program, if any, and analyze whether program revenues are sufficient to cover program costs.

17. We will report whether the District administrators are evaluated annually and, if so, explain how the results inform District operations.
18. In regard to the District's compensation system, we will provide a response to the following questions:
 - a. Does the District use salary bonuses or merit pay systems? If yes, explain the performance-based systems and the factors used
 - b. Do the District's salary ranges include minimum, midpoint, and maximum increments to promote compensation equity based on the employee's education, experience, and other relevant factors?
 - c. Does the District periodically adjust its compensation structure using verifiable salary survey information, benchmarking, and comparable salary data?
 - d. Has the District made any internal equity and/or market adjustments to salaries within the past two years?
19. In regard to planning, we will provide a response for each of the following questions:
 - a. Does the District develop a District Improvement Plan (DIP) annually?
 - b. Do all campuses in the District develop a Campus Improvement Plan (CIP) annually?
 - c. Does the District have an active and current facilities master plan? If yes, does the District consider these factors to inform the plan:
 - Does the District use enrollment projections?
 - Does the District analyze facility capacity?
 - Does the District evaluate facility condition?
 - d. Does the District have an active and current energy management plan?
 - e. Does the District maintain a clearly defined staffing formula for staff in maintenance, custodial, food service, and transportation?
20. In regard to District academic information, we will provide a response for each of the following questions:
 - a. Does the District have a teacher mentoring program?
 - b. Are decisions to adopt new programs or discontinue existing programs made based on quantifiable data and research?
 - c. When adopting new programs, does the District define expected results?
 - d. Does the District analyze student test results at the district and/or campus level to design, implement and/or monitor the use of curriculum and instructional programs?
 - e. Does the District modify programs, plan staff development opportunities, or evaluate staff based on analyses of student test results?

Audit Procedures – General

We will provide observations or conclusions based on our evaluation of sufficient, appropriate evidence to assess the District's fiscal management, efficiency, utilization of resources, and whether the District has implemented best practices utilized by other Texas school districts, which have a high likelihood of improving student academic achievement result. Our audit will provide objective analysis to assist taxpayers, management, and the Board of Trustees in using the information to assess whether the District's expenditures align with cost-effective and best practices, utilized by other Texas school districts, to improve student results. In addition, our efficiency audit does not constitute an engagement to provide audit, compilation, review, or attestation services as described in the pronouncements on professional standards issued by the AICPA, the Public Company Accounting Oversight Board, or other regulatory body and, therefore, we will not express an opinion or any form of assurance as result of our efficiency audit.

Because the determination of abuse is subjective, *Government Auditing Standards* do not expect auditors to provide reasonable assurance of detecting abuse.

Management's Responsibilities

The District is responsible for designing and implementing effective internal control. In addition, the District will be responsible for ensuring that all key District personnel actively participate in both the planning and execution of this engagement.

You are responsible for the design and implementation of programs and controls to prevent and detect fraud, and for informing us about all known or suspected fraud affecting the government involving (1) management, (2) employees who have significant roles in internal control, and (3) others where the fraud could lead to material noncompliance. Your responsibilities include informing us of your knowledge of any allegations of fraud or suspected fraud affecting the government received in communications from employees, former employees, grantors, regulators, or others. In addition, you are responsible for identifying and ensuring that the government complies with applicable laws, regulations, contracts, agreements, and grants and for taking timely and appropriate steps to remedy fraud and noncompliance with provisions of laws, regulations, contracts or grant agreements, or abuse that we report.

Engagement Administration, Fees, and Other

We understand that your staff will assist us in obtaining hard and electronic copies of all the information we request. We will provide the District with our report; however, management is responsible for distribution of the reports to others. This includes complying with the requirements stipulated in House Bill 3 that resulted from the 86th Texas Legislature. If an electronic copy of information is not available, then your staff shall provide access for review of the hard copy information. You are under no obligation to convert hard copy files into electronic files.

The final efficiency audit reports that Duran & Associates prepares, and delivers are the property of the District. However, internal working papers that Duran & Associates generate as well as the confidential methods used by the firm are proprietary and confidential to the firm. However, we may be requested to make certain audit documentation available pursuant to authority given by law or regulation, or to peer reviewers. We will notify you of any such request. If requested and a legal obligation exists for us to provide such documentation, access to such efficiency audit documentation will be provided under the supervision of Duran & Associates personnel. Furthermore, upon request and a legal obligation exists for us to provide such documentation, we may provide copies of selected efficiency audit documentation to the applicable parties. These parties may intend, or decide, to distribute copies or information contained therein to others, including other governmental agencies. All materials that Duran & Associates provides to the District are subject to the Texas Public Information Act (TPIA). Certain materials may be exempt from production pursuant to the Act depending upon the request. Duran & Associates merely as a vendor to the District is not subject to the TPIA. Therefore, its internal working papers are not subject to the TPIA.

The efficiency audit documentation for this engagement will be retained for a minimum of five years after the report release date or for any additional period requested by a qualified regulatory agency.

We expect to begin our efficiency audit on or about June 15, 2025 or as soon as is practical for our engagement team and the District's staff. We anticipate that we will complete our audit by August 11, 2025. Stephanie Duran, CPA is the engagement partner and is responsible for supervising the engagement and signing the reports.

Our fees for these services are estimated at \$6,250. Our standard hourly rates vary according to the degree of responsibility involved and the experience level of the personnel assigned to the project. We will render invoices as work progresses-as follows:

- Beginning of audit \$3,125
- End of audit (report draft issued) \$3,125

These invoices will be payable within thirty (30) days of receipt. In accordance with our firm policies, work may be suspended if your account becomes 60 days or more overdue and may not be resumed until your account is paid in full.

We appreciate the opportunity to be of service to the District and believe this letter accurately summarizes the significant terms of our engagement. If you have any questions, please let us know. If you agree with the terms of our engagement as described in this letter, please sign the enclosed copy, and return it to us.

Our engagement ends on delivery of our efficiency audit report. Any follow-up services that might be required will be a separate, new engagement. The terms and conditions of that new engagement will be governed by a new, specific engagement letter for that service.

Sincerely yours,

RESPONSE:

This letter correctly sets forth the understanding of Coupland Independent School District.

Signature: _____

Title: _____

Date: _____



Board of Trustees

Date of Meeting

Item Type

Item Name	
District Goal	
Summary (Purpose / Objective)	
Fiscal Impact	
Administrative Recommendation	

Attachments	
-------------	--

Contact Person

E-Mail Address



Special Education Director Responsibilities

- Establish policies and procedures for the ARD and Assessment processes.
- Supervise the Special Education department to include Special Education Teachers, Ed. Diag., SLP, and any Para educators involved in the processes.
- Assure all future and previously identified students in Coupland ISD are assessed: according to state/federal laws, within timelines, and written reports are of high quality (including contracted assessments).
- Oversee the SPP, TEAL and any other TEA reporting requirements are completed accurately and on-time.
- Attend and facilitate ARDs (if necessary).
- Assure all paperwork is complete and compliant.
- Other responsibilities as appropriate and assigned



Board of Trustees

Date of Meeting
Item Type

Item Name	
District Goal	
Summary (Purpose / Objective)	
Fiscal Impact	
Administrative Recommendation	

Attachments	
-------------	--

Contact Person E-Mail Address



Board of Trustees

Date of Meeting
Item Type

Item Name	
District Goal	
Summary (Purpose / Objective)	
Fiscal Impact	
Administrative Recommendation	

Attachments	
-------------	--

Contact Person E-Mail Address



Coupland ISD 2025-2026 Goals

Goal # 1: Academic Achievement

- The percent of 3rd grade students that score meets grade level or above on STAAR RLA will increase from 29% to 42% by June 2029. (HB3)
- The percentage of 3rd grade students whose score meets grade level or above on STAAR Math will increase from 32% to 45% by June 2029. (HB3)
- Increase the number of areas that Coupland ISD is exceeding the state (or Region 13) for Approaches, Meets, and Masters in Reading, Math, Science and Social Studies (STAAR Performance).

Goal # 2: Effective & Efficient Operations

- Include the Strategic Plan in decision making and evaluate progress, successes, and challenges annually. Use information gleaned from annual evaluations to guide and inform continual efforts to transform Coupland ISD into a destination school district in Central Texas.
- The district will evaluate current facilities to meet the needs of our students. Current enrollment, course offerings, and the effective use of facilities will be analyzed to develop a plan that best leverages district resources.

Goal # 3: Board/Staff/Community Relationship

- The district will foster communication and collaboration to ensure that the school district effectively serves the needs of its students, families, and the wider community. This includes proactively informing the community about the district's activities, seeking community input, and involving residents in decision-making processes.

Action and Discussion Items Calendar

Month	Action Items	Reports/Information/Discussion Items
September	<ul style="list-style-type: none"> ● Class Size Waivers (if necessary) ● Approval of District/Campus Improvement Plan ● Approve Bastrop & Williamson County Adjunct Faculty Agreements ● Approve Investment Officer(s) 	<ul style="list-style-type: none"> ● Procedures for dismissal of school due to weather conditions ● Beginning School Enrollment Report ● Free & Reduced Lunch Information
October	<ul style="list-style-type: none"> ● Approval of tax roll resolution Williamson County and Travis County Appraisal Districts ● Set Board meeting for canvassing election return (even years only) ● Announcement of Board Continuing Education hours 	<ul style="list-style-type: none"> ● Staff Appreciation Event Planning ● Plan annual Team of 8 training
November	<ul style="list-style-type: none"> ● Induct new Board members ● Board Reorganization ● Canvass Ballots for trustee election (Oath of Office) ● HB 3033 Business days ● Public Hearing - FIRST 	<ul style="list-style-type: none"> ● Fall ADA Report ● October special population enrollment: bilingual/ESL students ● Canvas ballots for trustee/special election (special meeting) Oath of Office (Even years only) ● Public Hearing – FIRST ● Financial Rating Workshop ● Provide new board member(s) with local orientation ● Plan for Superintendent Evaluation and set evaluation date
December	<ul style="list-style-type: none"> ● Review of Board Operating Procedures ● Annual Financial Audit report for Prior Year (PY) 	<ul style="list-style-type: none"> ● Consider budget plan / timeline ● Staff Appreciation Event ● Superintendent delivers self-evaluation and required evaluation reports
January	<ul style="list-style-type: none"> ● Commit Fund Balance ● Public Hearing - TAPR ● Superintendent Annual 	<ul style="list-style-type: none"> ● Superintendent's evaluation form approved if changes needed

	<p>(Summative) Evaluation</p> <ul style="list-style-type: none"> ● Superintendent Contract Consideration 	<ul style="list-style-type: none"> ● Begin District Goal Setting ● Determine/plan summer projects ● Set Superintendent Goals for the following year
February	<ul style="list-style-type: none"> ● Adopt School Calendar for next school year ● Approve audit firm for upcoming year ● Determine/plan summer projects 	<ul style="list-style-type: none"> ● Proposed School Calendar ● Discipline Report ● Board Self-Evaluation ● Continue District Goal Setting
March	<ul style="list-style-type: none"> ● Teacher Contract Renewals ● Approve PD Waiver ● Finalize district goals ● Establish district goals ● Approve Summer Work Hours 	<ul style="list-style-type: none"> ● Review of Technology Plan Updates ● Set calendar for end of year activities/graduation ● Board Self-Evaluation
April	<ul style="list-style-type: none"> ● Approve summer projects ● IMA & TEKS Certification ● Board Self-Evaluation ● Review compensation/benefits package 	<ul style="list-style-type: none"> ● ESL & Summer School Plan ● Initial Budget Workshop – School Finance ● Receive Preliminary Values ● Plan Team of 8 training
May	<ul style="list-style-type: none"> ● Bank Depository Bids (every other year) 	<ul style="list-style-type: none"> ● Begin Budget Planning ● Review professional development report ● Review District/Campus Improvement Plan
June	<ul style="list-style-type: none"> ● Superintendent Annual (Formative) Evaluation ● Superintendent Contract Consideration ● Cafeteria Services Report and Prices for the next year ● Intent to Apply for ESSA/Grant Funds ● MOU for DAEP 	<ul style="list-style-type: none"> ● Budget Workshop – DRAFT 2025-2026 Budget ● Consider new or modified programs for upcoming school year ● Review Employee/Staff Handbook Draft ● Review Student Handbook & Code of Conduct Draft
July	<ul style="list-style-type: none"> ● Approve Code of Conduct ● Approve Employee Handbook ● Order Trustee election and approve contract for election services (Even years only) ● Establish Trustee Election Dates (Even years only) 	<ul style="list-style-type: none"> ● Budget Workshop – Preliminary 2025-2026 Budget ● Consider TASB attendance at TASB Conference in September ● Select TASB Delegate and Alternate ● Receive Certified Values (7/25)

<p>August</p>	<ul style="list-style-type: none"> ● Approve Proposed 2025-2026 Budget ● Amend budget for previous year ● Accept certification of appraisal roll for the certified taxable value ● Approval of clubs for extra-curricular absence purposes ● Approve district teacher appraisal calendar ● Set the Tax Rate (Special Board Meeting) ● Budget Hearing (Special Board Meeting) 	<ul style="list-style-type: none"> ● Review Multi-Hazard Emergency Operations Plan
---------------	--	---

Revised January 2025

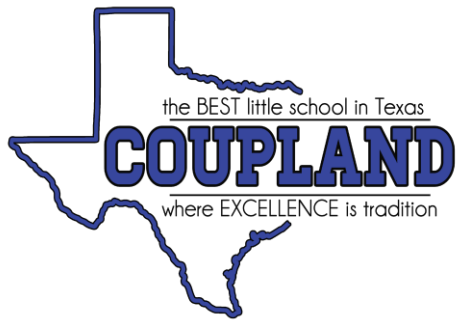

COUPLAND ISD

620 S COMMERCE ST
COUPLAND, TX 78615
512-856-2422

Future Board Meetings

- July 17, 2025
- August 14, 2025*
- September 11, 2025
- October 9, 2025
- November 13, 2025
- November 18, 2025*
- December 11, 2025
- January 15, 2026
- February 12, 2026
- March 12, 2026
- April 9, 2026
- May 14, 2026
- June 11, 2026



Board of Trustees

Date of Meeting
Item Type

Item Name	
District Goal	
Summary (Purpose / Objective)	
Fiscal Impact	
Administrative Recommendation	

Attachments	
-------------	--

Contact Person E-Mail Address



Board of Trustees

Date of Meeting	
Item Type	

Item Name	
District Goal	
Summary (Purpose / Objective)	
Fiscal Impact	
Administrative Recommendation	

Attachments	
-------------	--

Contact Person	<input type="text"/>	E-Mail Address	<input type="text"/>
----------------	----------------------	----------------	----------------------