

# Capital Projects Committee of the Whole

Thursday, March 5, 2026 4:00 PM

Educational Services Building, 25425 Taft Road, Novi, MI 48374

## I. CALL TO ORDER

## II. NEW BUSINESS

II.a. Elementary Playground Equipment Award  
(First Read)

II.b. Bond Series I and II Projects Update

II.b.1. Elementary Playgrounds - Woods, Parkview,  
ECEC

II.b.2. High School Turf and Track Replacement

II.b.3. District-Wide Practice Fields Phase I -  
Meadows

II.b.4. Wellness Center

II.b.5. High School Innovation Hub Addition

II.b.6. One-for-One Mechanical Replacements

II.c. Novi Activity Center - High School

II.c.1. Update with the City of Novi Negotiations

II.c.2. Schedule Review and Discussion

## III. COMMENTS FROM THE AUDIENCE

## IV. ADJOURNMENT



CELEBRATING 20 YEARS  
Fielding  
International



March 5th, 2026

# NCSD Capital Projects Committee of the Whole 2025 Bond Construction Update



We are **designers.** We are **builders.**  
*And* we are **educators.**

**Stewart Reich, Kingscott**



**John Davids, Kingscott**



**Travis Pennock, Fielding Int'l.**



**Allyza Danica, Fielding Int'l.**



**Pam Hartsell, Kingscott**



**Jason Ide, Christman**



**Brad Anderson, Christman**

# BOND HIGHLIGHTS



## BOND HIGHLIGHTS

### NOVI HIGH SCHOOL: A BOLD, COMPREHENSIVE VISION & PLAN

- New academic innovation hub, event commons, and skylight atrium
- New multi-sport courts, an indoor track, a turf field, a natatorium, and a competition gym
- Performing arts lobby addition and extensive auditorium remodel
- Expansion and remodel of the Black Box Theatre and band/orchestra rooms

### NOVI K-8: ADDITIONS, SAFETY, & NECESSARY BUILDING IMPROVEMENTS

- Elementary classroom additions, extensive remodeling, and playground improvements
- Middle school STEM addition, secure athletic wing entrance, new turf field, and concessions complex

### BUSES, FURNITURE, FIXTURES, EQUIPMENT, & TECHNOLOGY

- Equip learning spaces with smart technology and modern furniture
- Provide the necessary equipment to create supportive environments





# EARLY PROJECTS

# EARLY PROJECTS | Playground Upgrades - ECEC

**UPDATE WITH IMAGES**

# EARLY PROJECTS | Playground Upgrades - Novi Woods

**UPDATE WITH IMAGES**

# EARLY PROJECTS | Playground Upgrades - Parkview

**UPDATE WITH IMAGES**

# EARLY PROJECTS | Novi Wellness Center



# EARLY PROJECTS | Novi Meadows Practice Field



# EARLY PROJECTS | Novi Meadows Practice Field

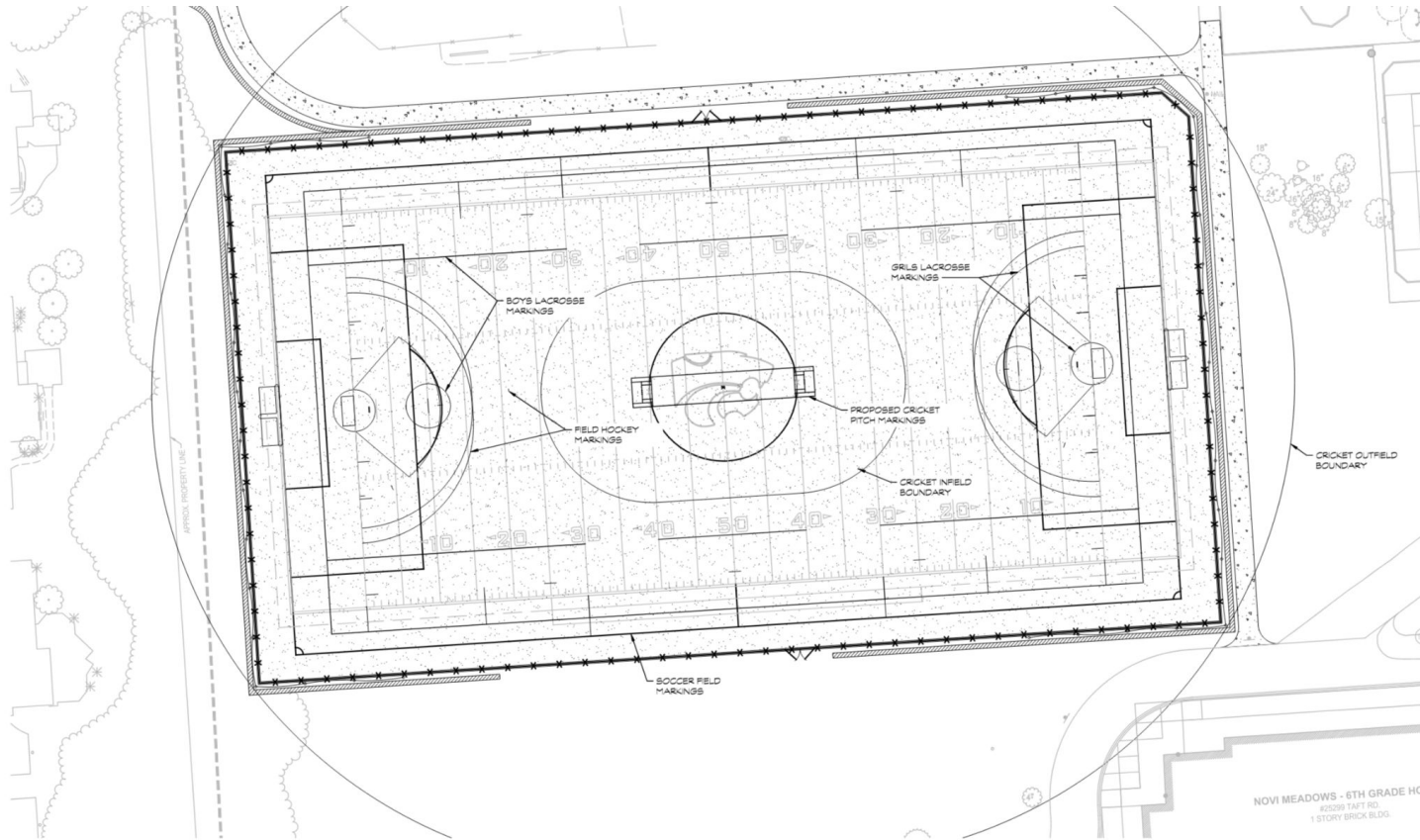

# EARLY PROJECTS | NHS Track & Turf Replacement



# EARLY PROJECTS | Novi High School Zones

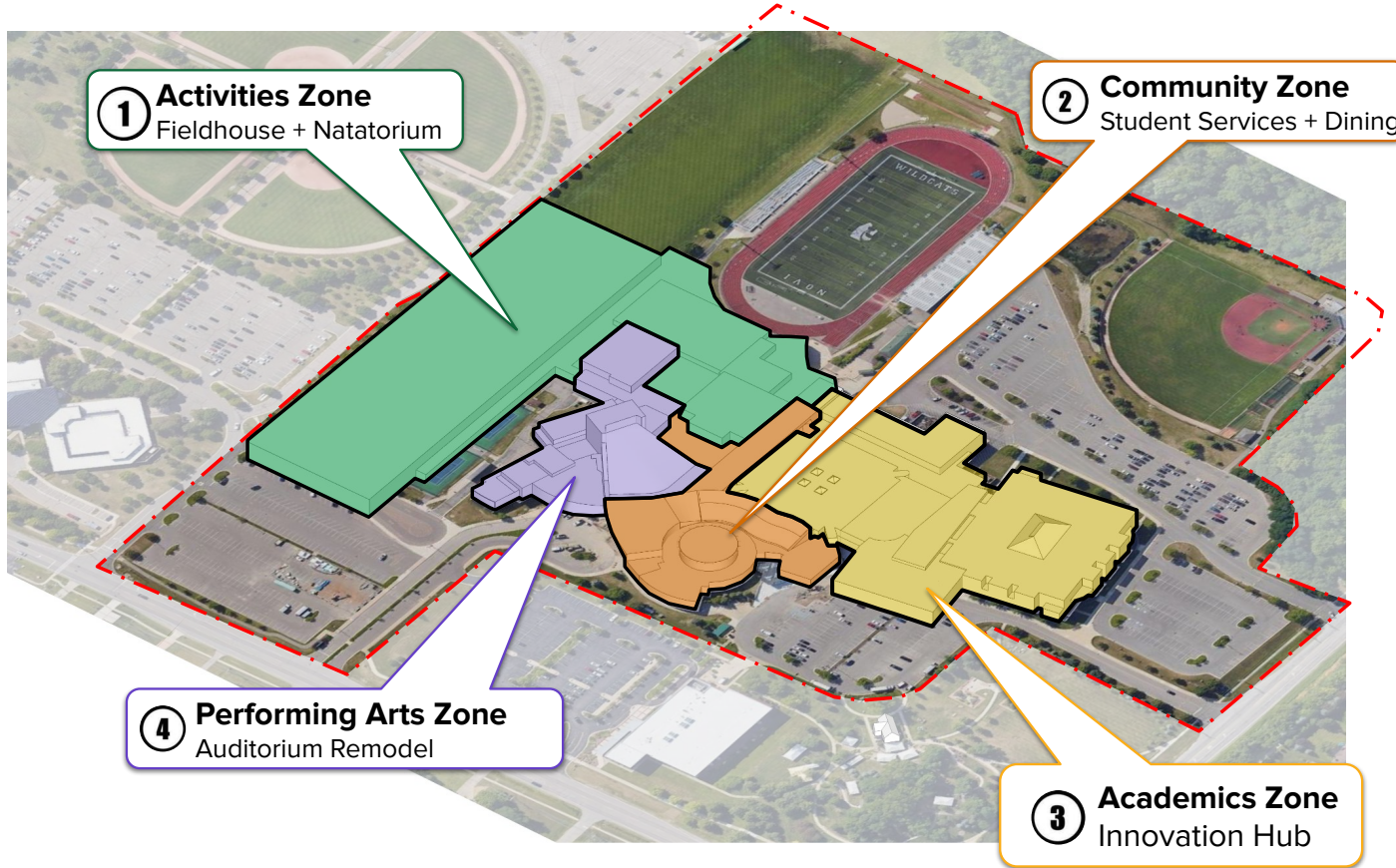

# PROJECT SCHEDULE | 'Every Student Impacted in First Two Years'

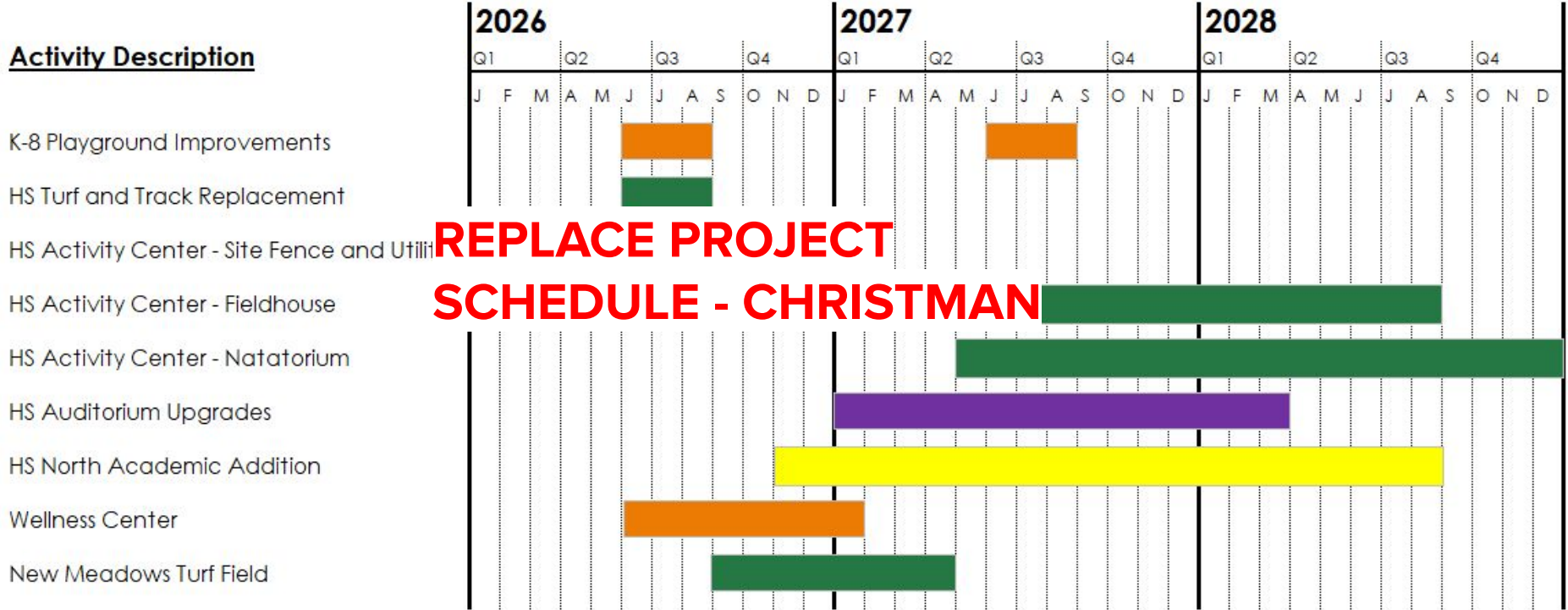



# ACTIVITY CENTER

# OVERALL PLAN | Level 01 - Main Floor

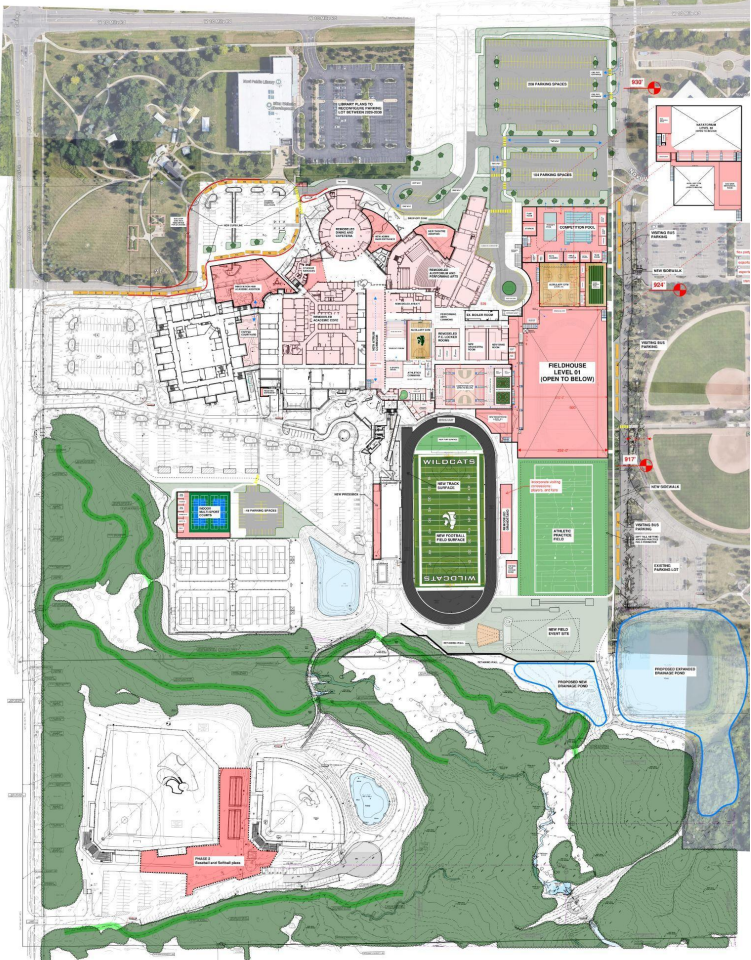

# OVERALL PLAN | Level 01 - Main Floor

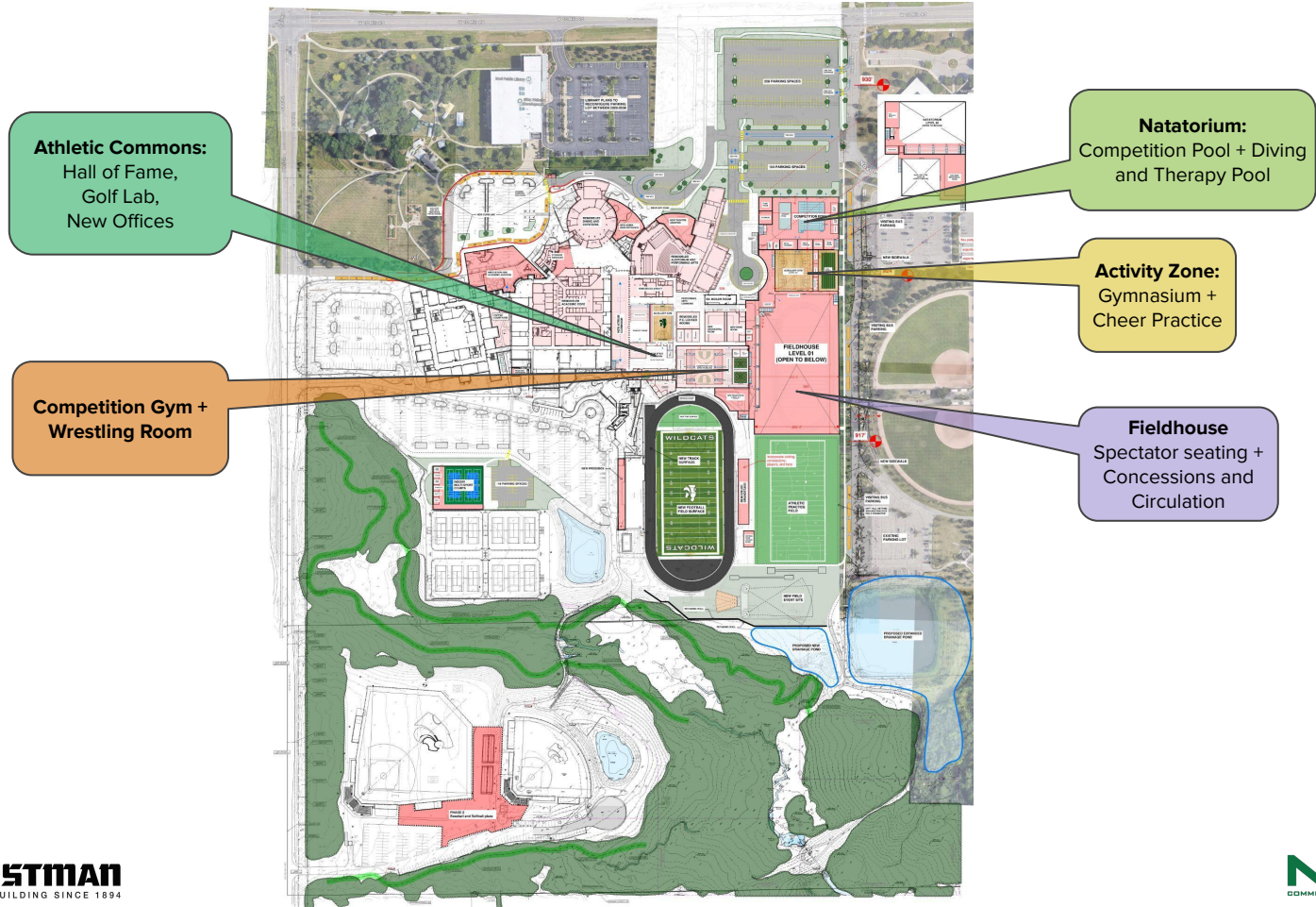

# OVERALL PLAN | Level 00 - Lower Level / Site

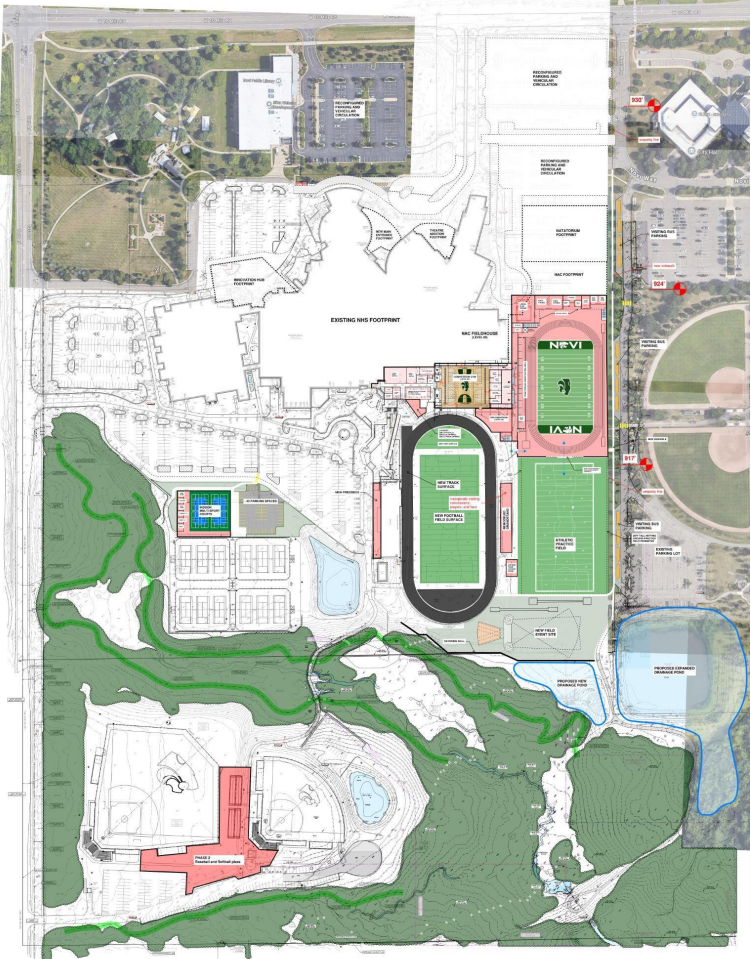

# OVERALL PLAN | Level 00 - Lower Level / Site

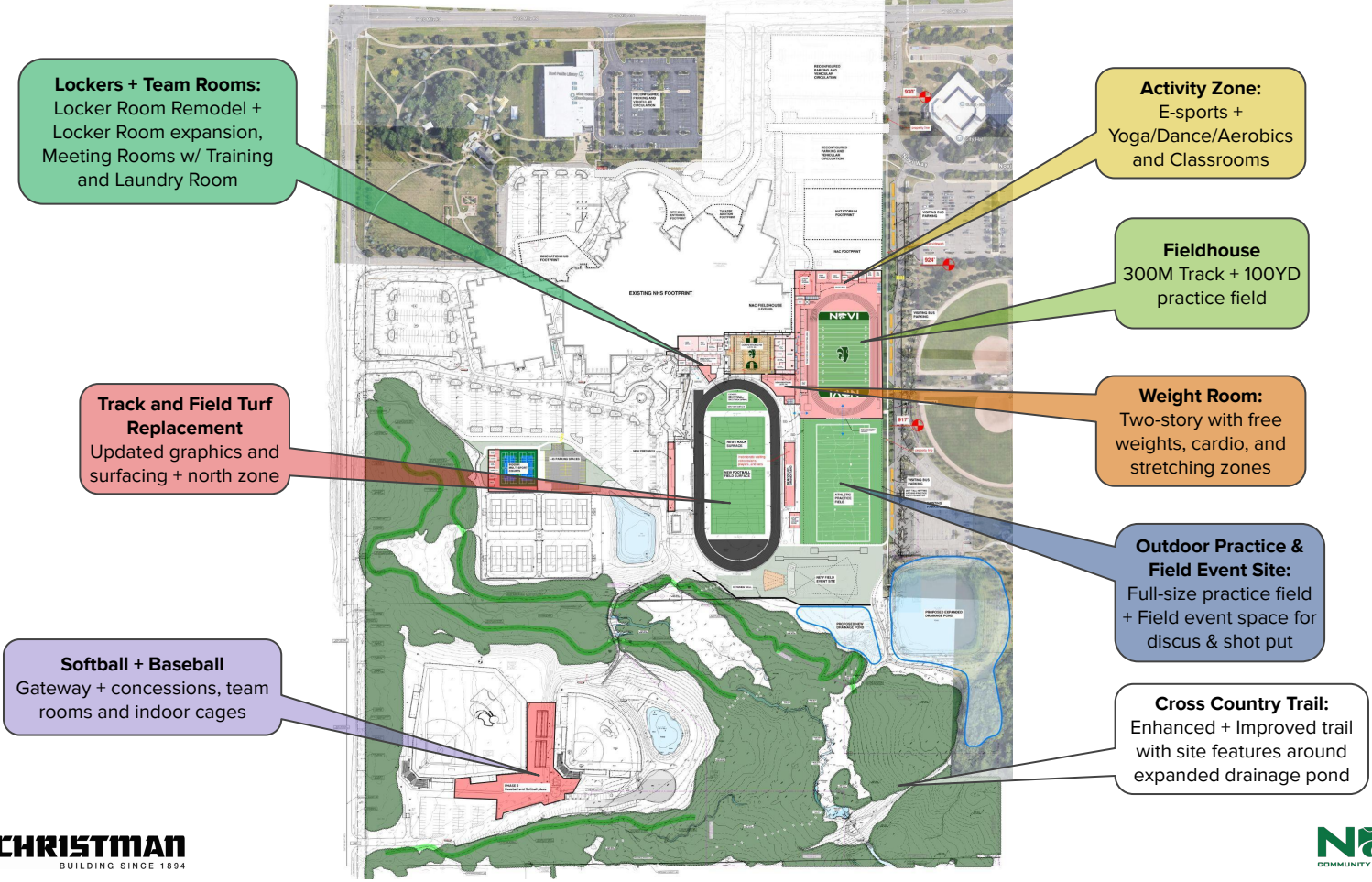

# ACTIVITY CENTER - FIELDHOUSE



# ACTIVITY CENTER - NATATORIUM



# COMPETITION GYMNASIUM





# PERFORMING ARTS

# PERFORMING ARTS REMODEL

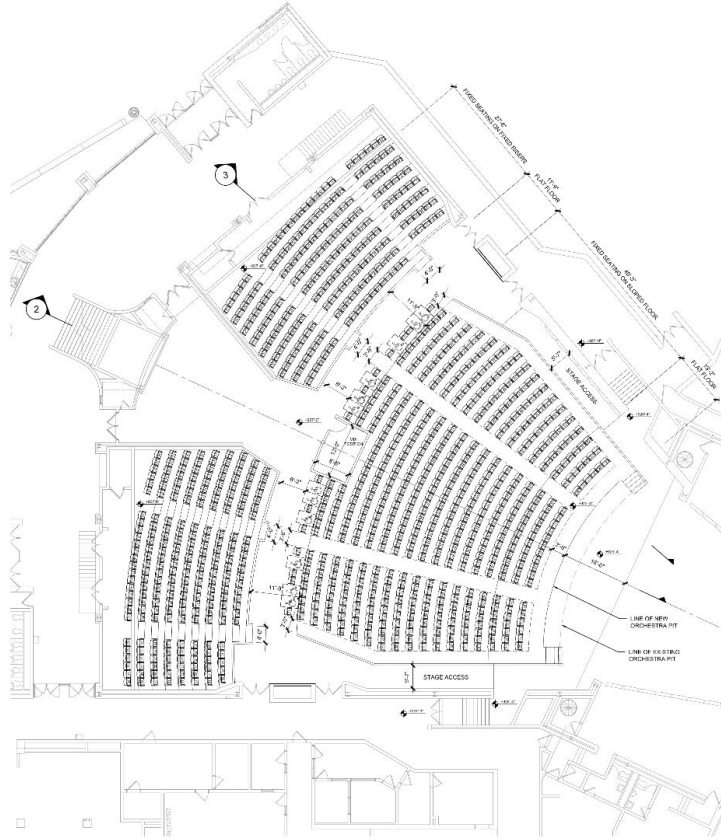

1 SEATING PLAN  
1/8" = 1'-0"

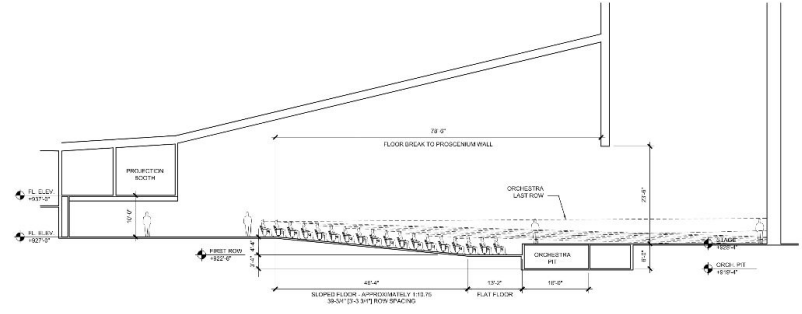

2 CENTERLINE / SIGHTLINE SECTION (section through mix position not shown for clarity)  
1/8" = 1'-0"

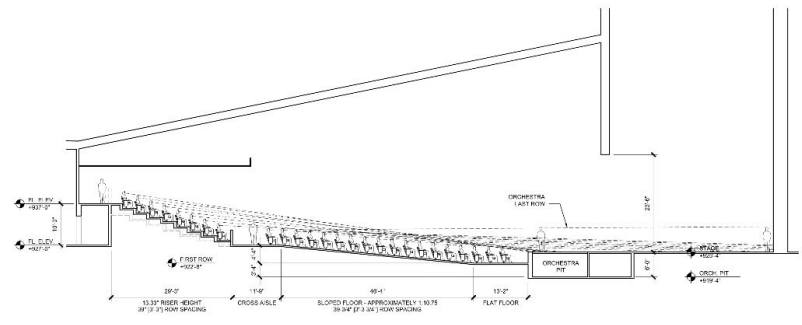

3 SIGHTLINE SECTION  
1/8" = 1'-0"

# PERFORMING ARTS REMODEL



# PERFORMING ARTS REMODEL



# PERFORMING ARTS REMODEL



# BAND / ORCHESTRA



# PERFORMING ARTS EXPANSION



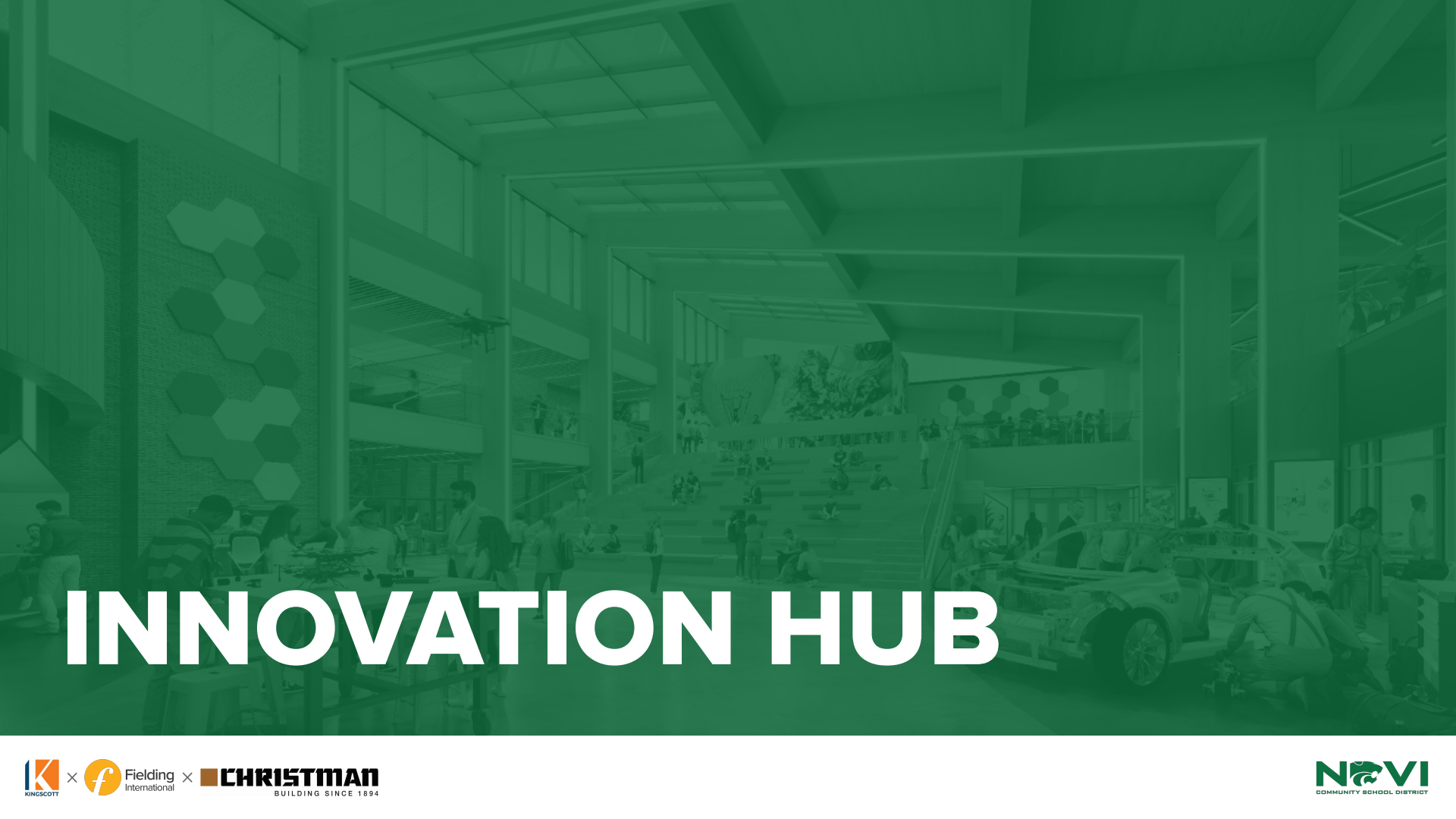

# INNOVATION HUB

## UPDATE WITH RENDERINGS

# INNOVATION HUB



# TRIUM CORRIDOR CONNECTOR





# THANK YOU!

March 3, 2026

Ben Mainka, Superintendent of Schools  
Novi Community School District  
25345 Taft Rd.  
Novi, MI 48374

RE: NCS D 2025 Bond Program  
Recommendation for Award – 2026 Playground Equipment and Surfacing

Dear Mr. Mainka:

This letter transmits an update from Plante Moran Realpoint (PMR) as it relates to the assignment to assist and advise the Novi Community School District (NCS D) in the procurement of consortium proposals for purchase of Field Turf for the High School Football Field (Project). This update represents the mutual efforts of PMR, The Christman Company, Kingscott Associates and NCS D Administration (The Project Team) to present a framework to identify, evaluate and recommend playground equipment and surfacing for this Project.

### **SELECTION PROCESS**

The Project Team solicited consortium proposals from Penchura, LLC to provide and install new playground equipment and surfacing for Novi Woods Elementary, Parkview Elementary, and the Early Childhood Education Center. Final Proposals were received on March 3, 2026, after multiple stakeholder and design meetings, and were reviewed by The Project Team for accuracy and completeness. The proposals include the furnishment and installation of new playground equipment as well as new poured in place surfacing. The scope of the proposals has been fully coordinated with an outstanding RFP for the balance of the playground improvements. A separate award recommendation for the balance of the playground improvements scope will be presented at a later date.

### **RECOMMENDATION**

The Project Team is recommending Penchura, LLC for award in the amount of *two million four hundred seven thousand three hundred nineteen dollars and forty-nine cents (\$2,407,319.49)*.

This total sum is subtotaled as follows:

#### **Novi Woods Elementary**

Equipment Purchase	\$337,848.81
Equipment Installation/Surfacing Preparation	\$166,500.00
<u>Poured in Place Surfacing</u>	<u>\$257,521.00</u>
<b><i>Novi Woods Elementary Subtotal</i></b>	<b><i>\$761,869.81</i></b>

***Parkview Elementary***

Equipment Purchase	\$413,310.58
Equipment Installation/Surfacing Preparation	\$256,472.00
<u>Poured in Place Surfacing</u>	<u>\$584,472.00</u>
<b><i>Parkview Elementary Subtotal</i></b>	<b><i>\$1,254,256.58</i></b>

***Early Childhood Education Center***

Equipment Purchase	\$53,724.30
Equipment Installation/Surfacing Preparation	\$69,126.00
Poured in Place Surfacing	\$185,567.80
<u>Artificial Turf Surfacing</u>	<u>\$82,775.00</u>
<b><i>Early Childhood Education Center Subtotal</i></b>	<b><i>\$391,193.10</i></b>

**Total Award** **\$2,407,219.49**

With the Board of Education’s approval, The Project Team will proceed with issuing contracts / purchase orders, place orders, and procure the playground equipment and surfacing materials and installation for the scheduled installation of Summer 2026.

Should you have any questions regarding this recommendation, or the selection process described above, please do not hesitate to contact me at 586-703-1044 or [kevin.donnelly@plantemoran.com](mailto:kevin.donnelly@plantemoran.com).

Sincerely,

Plante Moran Realpoint



Kevin Donnelly  
Senior Vice President

- Enclosures:
- Penchura, LLC – Proposal #26-222 – Poured in Place Surfacing
  - Penchura, LLC - Proposal #26-147 – ECEC Equipment Purchase
  - Penchura, LLC – Proposal #26-147-1 – ECEC Equipment Install & Surface Prep
  - Penchura, LLC - Proposal #26-222-1 – ECEC Turf Surfacing
  - Penchura, LLC - Proposal #26-151 – Novi Woods Equipment Purchase
  - Penchura, LLC - Proposal #26-151-1 – Novi Woods Equipment Install & Surface Prep
  - Penchura, LLC – Proposal #26-156 – Parkview Equipment Purchase
  - Penchura, LLC – Proposal #26-156-1 – Parkview Equipment Install & Surface Prep
  - Penchura, LLC – Drawings and Renderings

Cc: Rebecca Scicluna, NCSD  
Michael Dragoo, NCSD  
Sandra Brasil, NCSD  
Jennifer Bueter, NCSD  
Greg VanKirk, PMR  
Shannon Momot, PMR  
Micah Swansey, PMR  
Brad Anderson, TCC  
Jason Ide, TCC  
Stewart Reich, Kingscott



Make all P.O.s, Contracts, and Checks to:  
**Penchura, L.L.C.**  
**889 S. Old US 23**  
**Brighton, MI 48114**

# Proposal

Date	Project #
2/20/2026	26-222

<b>Bill To</b>
Novi Schools - Admin Building Betsy 25345 Taft Rd. Novi, MI 48374

<b>Ship To</b>
Novi Meadows

<b>Customer Contact</b>	<b>Customer Phone</b>	<b>Customer Fax</b>	<b>Terms</b>	<b>P.O. No.</b>	<b>Rep</b>
John	248-255-1214	248-449-1249	Net 30		LAS

Item	Description	Qty	Weight	Price	Total
	2026 Surfacing quote Novi Preschool				
PIP - Install	Swing Area - 96" fall, 1,920 sq. ft.-3.5"	1,920		21.00	40,320.00
PIP - Install	Toddler Area - 30" fall, 1,442 sq. ft.-2"	1,442		19.40	27,974.80
PIP - Install	Existing play area - 48" fall, 6,045 sq. ft.-2"	6,045		19.40	117,273.00
	Parview				
PIP - Install	North - 96" fall, 6,520 sq. ft.-3.5"	6,520		21.00	136,920.00
PIP - Install	Middle - 96" fall, 9,100 sq. ft.-3.5"	9,100		21.00	191,100.00
PIP - Install	South - 96" fall, 12,212 sq. ft.-3.5"	12,212		21.00	256,452.00
	Novi Woods				
PIP - Install	Upper Elementary - 96" fall, 9,471 sq. ft.-3.5"	9,471		21.00	198,891.00
PIP - Install	Lower Elementary - 79" fall, 2,860 sq. ft.-3"	2,860		20.50	58,630.00
	* Pricing is for 50/50 colo,black with Aromatic Binder and for the quantities listed above.				
	* Price does not include security for work performed, or dumpster.				

Proposal good for 30 days.  
 Ship Via: common carrier  
 Delivery contact name and number: \_\_\_\_\_

Customer signature below constitutes a purchase order.

<b>Subtotal</b>	\$1,027,560.80
<b>Sales Tax (0.0%)</b>	\$0.00
<b>Total</b>	\$1,027,560.80

**Credit Card fee of 3% on all payments using a CC.**  
**AMX fee of 5% on all payments using AMX**

889 S. Old US 23, Brighton, MI 48114  
 Office: (810) 229-6245 Fax: (810) 229-6256 Toll Free: (888) 778-7529



Please make check payable to:  
**Landscape Structures Inc**  
 601 7th Street S  
 Delano, MN 55328

# Proposal

Date	Proposal #
1/26/2026	26-151

Bill To:
<b>Novi Schools - Admin Building</b> <b>Betsy</b> <b>25345 Taft Rd.</b> <b>Novi, MI 48374</b>

Ship To
<b>Novi Meadows</b>

Customer Contact	Customer Phone	Customer Fax	Terms	P.O. No.	Rep
<b>John</b>	<b>248-255-1214</b>	<b>248-449-1249</b>	<b>Net 30</b>		<b>LAS</b>

Item	Description	Qty	Weight	Price	Total
	<b>Novi Woods</b>				
	<b>Lower Elementary</b>				
<b>PlayBooster</b>	<b>PlayBooster Playground Structure</b>			<b>69,431.40</b>	<b>69,431.40</b>
<b>152179A</b>	<b>Saddle Spinner</b>			<b>1,009.80</b>	<b>1,009.80</b>
<b>148637A</b>	<b>4-Seat Seesaw, Direct Bury</b>			<b>4,921.50</b>	<b>4,921.50</b>
<b>141683A</b>	<b>TT Coated Bench 72" w/Back Direct Bury (121 lbs)</b>			<b>882.30</b>	<b>882.30</b>
	<b>Upper Elementary</b>				
<b>PlayBooster</b>	<b>PlayBooster Playground</b>	<b>1</b>		<b>47,771.70</b>	<b>47,771.70</b>
<b>Evos</b>	<b>Evos Playstructure</b>	<b>1</b>		<b>62,189.40</b>	<b>62,189.40</b>
<b>323659A</b>	<b>Volo Play Structure, DB</b>	<b>1</b>		<b>89,530.50</b>	<b>89,530.50</b>
<b>120710A</b>	<b>Disc Climber 8"</b>	<b>1</b>		<b>397.80</b>	<b>397.80</b>
<b>247179A</b>	<b>Curva Spinner</b>	<b>1</b>		<b>2,682.60</b>	<b>2,682.60</b>
<b>218915A</b>	<b>Global Motion</b>	<b>1</b>		<b>40,386.90</b>	<b>40,386.90</b>
<b>173591A</b>	<b>OmniSpin Spinner, Surface Mount</b>	<b>1</b>		<b>11,709.60</b>	<b>11,709.60</b>
<b>152179A</b>	<b>Saddle Spinner</b>	<b>1</b>		<b>1,009.80</b>	<b>1,009.80</b>
<b>186490A</b>	<b>We-saw™ (DB Only)</b>	<b>1</b>		<b>15,192.90</b>	<b>15,192.90</b>
<b>158105A</b>	<b>Wobble Pod DB Only</b>	<b>3</b>		<b>2,198.10</b>	<b>6,594.30</b>
<b>182503C</b>	<b>Welcome Sign Ages 5-12 Direct Bury</b>	<b>1</b>		<b>0.00</b>	<b>0.00</b>
<b>141683A</b>	<b>TT Coated Bench 72" w/Back Direct Bury (121 lbs)</b>	<b>3</b>		<b>882.30</b>	<b>2,646.90</b>
<b>Freight</b>	<b>Freight</b>			<b>10,000.00</b>	<b>10,000.00</b>
<b>Sourcewell D...</b>	<b>Sourcewell Discount</b>			<b>-28,508.59</b>	<b>-28,508.59</b>

Proposal Good For 30 Days  
 Shipping Time: TBD  
 Ship Via: Common Carrier  
 Please call 24 hours prior to delivery: \_\_\_\_\_

<b>Subtotal</b>	\$337,848.81
<b>Sales Tax (0.0%)</b>	\$0.00
<b>Total</b>	\$337,848.81

Customer signature below constitutes a purchase order.



Make all P.O.s, Contracts, and Checks to:  
**Penchura, L.L.C.**  
 889 S. Old US 23  
 Brighton, MI 48114

# Proposal

Date	Project #
2/20/2026	26-151-1

<b>Bill To</b>
Novi Schools - Admin Building Betsy 25345 Taft Rd. Novi, MI 48374

<b>Ship To</b>
Novi Meadows

<b>Customer Contact</b>	<b>Customer Phone</b>	<b>Customer Fax</b>	<b>Terms</b>	<b>P.O. No.</b>	<b>Rep</b>
John	248-255-1214	248-449-1249	Net 30		LAS

Item	Description	Qty	Weight	Price	Total
Installation	Novi Woods Play Equipment installation and stone base Professional Certified Installation ~ Receive Equipment. ~ Layout / stake site. ~ Install all playground equipment and benches per drawing #: PEN1204083-01. ~ Install all playground equipment and benches per drawing #: PEN1204082-01.	1		107,750.00	107,750.00
Installation	Professional Certified Installation ~ Furnish and install 18,108 sf of aggregate base at a 4" compacted depth.	1		58,750.00	58,750.00

Proposal good for 30 days.  
 Ship Via: common carrier  
 Delivery contact name and number: \_\_\_\_\_

Customer signature below constitutes a purchase order.

\_\_\_\_\_

<b>Subtotal</b>	\$166,500.00
<b>Sales Tax (0.0%)</b>	\$0.00
<b>Total</b>	\$166,500.00

**Credit Card fee of 3% on all payments using a CC.**  
**AMX fee of 5% on all payments using AMX**

889 S. Old US 23, Brighton, MI 48114  
 Office: (810) 229-6245 Fax: (810) 229-6256 Toll Free: (888) 778-7529



Make all P.O.s, Contracts, and Checks to:  
**Penchura, L.L.C.**  
**889 S. Old US 23**  
**Brighton, MI 48114**

# Proposal

Date	Project #
2/20/2026	26-156-1

<b>Bill To</b>
Novi Schools - Admin Building Betsy 25345 Taft Rd. Novi, MI 48374

<b>Ship To</b>
Novi Meadows

<b>Customer Contact</b>	<b>Customer Phone</b>	<b>Customer Fax</b>	<b>Terms</b>	<b>P.O. No.</b>	<b>Rep</b>
John	248-255-1214	248-449-1249	Net 30		LAS

Item	Description	Qty	Weight	Price	Total
Installation	Parview Play Equipment installation and stone base South Professional Certified Installation Receive Equipment. ~ Layout / stake site. ~ Install all playground equipment and benches per the drawing #: PEN1204078-01-01 dated 2/2/2026 excluding the (2 ea) existing structures, (1 ea) existing Curva Spinner and (2 ea) existing benches.	1		47,312.00	47,312.00
Installation	Professional Certified Installation ~ Furnish and install 12,212 sf of aggregate base at a 4" compacted depth.	1		39,687.00	39,687.00
Installation	Middle Professional Certified Installation ~ Receive Equipment. ~ Layout / stake site. ~ Install all playground equipment and benches per the drawing #: PEN1204077-01-01 dated 2/3/2026.	1		81,500.00	81,500.00
Installation	Professional Certified Installation ~ Furnish and install 9,100 sf of aggregate base at a 4" compacted depth.	1		28,250.00	28,250.00
	North				

Proposal good for 30 days.  
 Ship Via: common carrier  
 Delivery contact name and number: \_\_\_\_\_

Customer signature below constitutes a purchase order.

\_\_\_\_\_

<b>Subtotal</b>
<b>Sales Tax (0.0%)</b>
<b>Total</b>

**Credit Card fee of 3% on all payments using a CC.**  
**AMX fee of 5% on all payments using AMX**

889 S. Old US 23, Brighton, MI 48114  
 Office: (810) 229-6245 Fax: (810) 229-6256 Toll Free: (888) 778-7529



Make all P.O.s, Contracts, and Checks to:  
**Penchura, L.L.C.**  
**889 S. Old US 23**  
**Brighton, MI 48114**

# Proposal

Date	Project #
2/20/2026	26-156-1

<b>Bill To</b>
Novi Schools - Admin Building Betsy 25345 Taft Rd. Novi, MI 48374

<b>Ship To</b>
Novi Meadows

<b>Customer Contact</b>	<b>Customer Phone</b>	<b>Customer Fax</b>	<b>Terms</b>	<b>P.O. No.</b>	<b>Rep</b>
John	248-255-1214	248-449-1249	Net 30		LAS

Item	Description	Qty	Weight	Price	Total
Installation	Professional Certified Installation ~ Receive Equipment. ~ Layout / stake site. ~ Install all playground equipment and bench per the drawing #: PEN1204076-01-01 dated 2/3/2026.	1		38,125.00	38,125.00
Installation	Professional Certified Installation ~ Furnish and install 6,520 sf of aggregate base at a 4" compacted depth.	1		21,500.00	21,500.00

Proposal good for 30 days.  
 Ship Via: common carrier  
 Delivery contact name and number: \_\_\_\_\_

Customer signature below constitutes a purchase order.

\_\_\_\_\_

<b>Subtotal</b>	\$256,374.00
<b>Sales Tax (0.0%)</b>	\$0.00
<b>Total</b>	\$256,374.00

**Credit Card fee of 3% on all payments using a CC.**  
**AMX fee of 5% on all payments using AMX**

889 S. Old US 23, Brighton, MI 48114  
 Office: (810) 229-6245 Fax: (810) 229-6256 Toll Free: (888) 778-7529



Please make check payable to:  
**Landscape Structures Inc**  
 601 7th Street S  
 Delano, MN 55328

# Proposal

Date	Proposal #
1/26/2026	26-156

Bill To:
<b>Novi Schools - Admin Building</b> <b>Betsy</b> <b>25345 Taft Rd.</b> <b>Novi, MI 48374</b>

Ship To
<b>Novi Meadows</b>

Customer Contact	Customer Phone	Customer Fax	Terms	P.O. No.	Rep
<b>John</b>	<b>248-255-1214</b>	<b>248-449-1249</b>	<b>Net 30</b>		<b>LAS</b>

Item	Description	Qty	Weight	Price	Total
	<b>Parkview Elementary</b>				
	<b>North Playground</b>				
<b>PlayBooster</b>	<b>PlayBooster Playground</b>	<b>1</b>		<b>49,021.20</b>	<b>49,021.20</b>
<b>295696A</b>	<b>ReviRock Bouncer DB Only</b>	<b>1</b>		<b>6,211.80</b>	<b>6,211.80</b>
<b>168099A</b>	<b>Cozy Dome</b>	<b>1</b>		<b>6,339.30</b>	<b>6,339.30</b>
<b>182503C</b>	<b>Welcome Sign Ages 5-12 Direct Bury</b>	<b>1</b>		<b>0.00</b>	<b>0.00</b>
<b>141683A</b>	<b>TT Coated Bench 72" w/Back Direct Bury (121 lbs)</b>	<b>1</b>		<b>882.30</b>	<b>882.30</b>
<b>174018A</b>	<b>Belt Seat w/Chains ProGuard Chains for 8' Beam Height</b>	<b>5</b>		<b>178.50</b>	<b>892.50</b>
<b>352219A</b>	<b>Flexx™ Swing w/Single Post Swing Frame 52" Bury</b>	<b>1</b>		<b>7,313.40</b>	<b>7,313.40</b>
<b>177351A</b>	<b>Molded Bucket Seat w/Harness &amp; ProGuard Chains for 8' Beam Height</b>	<b>1</b>		<b>1,218.90</b>	<b>1,218.90</b>
<b>177345A</b>	<b>Single Post Swing Frame 52" Bury Additional Bay 8' Beam Height Only</b>	<b>3</b>		<b>1,382.10</b>	<b>4,146.30</b>
<b>Freight</b>	<b>Freight</b>	<b>1</b>		<b>3,000.00</b>	<b>3,000.00</b>
<b>Sourcewell D...</b>	<b>Sourcewell Discount</b>			<b>-6,082.06</b>	<b>-6,082.06</b>
	<b>Middle Playground</b>				
<b>PlayBooster</b>	<b>PlayBooster Playground</b>	<b>1</b>		<b>45,588.90</b>	<b>45,588.90</b>
<b>265928D</b>	<b>Hedra™ w/Alpine™ Slide, Perf, Perf Panels</b>	<b>1</b>		<b>107,497.80</b>	<b>107,497.80</b>
<b>322403A</b>	<b>Quantis® A.2 DB</b>	<b>1</b>		<b>39,494.40</b>	<b>39,494.40</b>
<b>173908A</b>	<b>Log Stepper 18"</b>	<b>1</b>		<b>1,397.40</b>	<b>1,397.40</b>
<b>173907A</b>	<b>Log Stepper 8"</b>	<b>2</b>		<b>1,020.00</b>	<b>2,040.00</b>

Proposal Good For 30 Days  
 Shipping Time: TBD  
 Ship Via: Common Carrier  
 Please call 24 hours prior to delivery: \_\_\_\_\_

Customer signature below constitutes a purchase order.

<b>Subtotal</b>
<b>Sales Tax (0.0%)</b>
<b>Total</b>

Penchura, LLC, 889 S. Old US 23 Brighton, MI 48114  
 Office: (810) 229-6245 Fax: (810) 229-6256 Toll Free: (888) 778-7529



Please make check payable to:  
**Landscape Structures Inc**  
**601 7th Street S**  
**Delano, MN 55328**

# Proposal

Date	Proposal #
1/26/2026	26-156

Bill To:
<b>Novi Schools - Admin Building</b> <b>Betsy</b> <b>25345 Taft Rd.</b> <b>Novi, MI 48374</b>

Ship To
<b>Novi Meadows</b>

Customer Contact	Customer Phone	Customer Fax	Terms	P.O. No.	Rep
<b>John</b>	<b>248-255-1214</b>	<b>248-449-1249</b>	<b>Net 30</b>		<b>LAS</b>

Item	Description	Qty	Weight	Price	Total
247179A	Curva Spinner	1		2,682.60	2,682.60
205800A	TopsyTurny Spinner	1		7,073.70	7,073.70
158105A	Wobble Pod DB Only	1		2,198.10	2,198.10
355992A	Symbol Communication Sign English-English w/2 Post 2"SM	1		2,346.00	2,346.00
182503C	Welcome Sign Ages 5-12 Direct Bury	1		0.00	0.00
141683A	TT Coated Bench 72" w/Back Direct Bury (121 lbs)	3		882.30	2,646.90
173596A	Log Balance Beam	1		5,069.40	5,069.40
174018A	Belt Seat w/Chains ProGuard Chains for 8' Beam Height	6		178.50	1,071.00
177332A	Single Post Swing Frame 8' Beam Height	1		1,744.20	1,744.20
177333A	Single Post Swing Frame Additional 8' Bay	2		1,296.42	2,592.84
<b>Freight</b>	<b>Freight</b>	<b>1</b>		<b>6,000.00</b>	<b>6,000.00</b>
<b>Sourcewell D...</b>	<b>Sourcewell Discount</b>			<b>-17,875.30</b>	<b>-17,875.30</b>
	<b>South Playground</b>				
210739A	Venti	1		58,221.60	58,221.60
194704A	Boogie Board, Freestanding	1		3,503.70	3,503.70
218915A	Global Motion			40,386.90	40,386.90
173591A	OmniSpin Spinner, Surface Mount	1		11,709.60	11,709.60
148638A	LSI Stand-Up Seesaw	1		3,621.00	3,621.00
141683A	TT Coated Bench 72" w/Back Direct Bury (121 lbs)	2		882.30	1,764.60
174018A	Belt Seat w/Chains ProGuard Chains for 8' Beam Height	10		178.50	1,785.00
352219A	Flexx™ Swing w/Single Post Swing Frame 52" Bury	1		7,313.40	7,313.40

Proposal Good For 30 Days  
 Shipping Time: TBD  
 Ship Via: Common Carrier  
 Please call 24 hours prior to delivery: \_\_\_\_\_

Customer signature below constitutes a purchase order.

<b>Subtotal</b>
<b>Sales Tax (0.0%)</b>
<b>Total</b>

Penchura, LLC, 889 S. Old US 23 Brighton, MI 48114  
 Office: (810) 229-6245 Fax: (810) 229-6256 Toll Free: (888) 778-7529



Please make check payable to:  
**Landscape Structures Inc**  
 601 7th Street S  
 Delano, MN 55328

# Proposal

Date	Proposal #
1/26/2026	26-156

Bill To:
<b>Novi Schools - Admin Building</b> <b>Betsy</b> <b>25345 Taft Rd.</b> <b>Novi, MI 48374</b>

Ship To
<b>Novi Meadows</b>

Customer Contact	Customer Phone	Customer Fax	Terms	P.O. No.	Rep
<b>John</b>	<b>248-255-1214</b>	<b>248-449-1249</b>	<b>Net 30</b>		<b>LAS</b>

Item	Description	Qty	Weight	Price	Total
<b>177345A</b>	<b>Single Post Swing Frame 52" Bury Additional Bay 8' Beam Height Only</b>	<b>5</b>		<b>1,382.10</b>	<b>6,910.50</b>
<b>Freight</b>	<b>Freight</b>	<b>1</b>		<b>4,500.00</b>	<b>4,500.00</b>
<b>Sourcewell D...</b>	<b>Sourcewell Discount</b>			<b>-10,817.30</b>	<b>-10,817.30</b>

Proposal Good For 30 Days  
 Shipping Time: TBD  
 Ship Via: Common Carrier  
 Please call 24 hours prior to delivery: \_\_\_\_\_

Customer signature below constitutes a purchase order.

<b>Subtotal</b>	\$413,410.58
<b>Sales Tax (0.0%)</b>	\$0.00
<b>Total</b>	\$413,410.58

Penchura, LLC, 889 S. Old US 23 Brighton, MI 48114  
 Office: (810) 229-6245 Fax: (810) 229-6256 Toll Free: (888) 778-7529



Please make check payable to:  
**Landscape Structures Inc**  
 601 7th Street S  
 Delano, MN 55328

# Proposal

Date	Proposal #
1/26/2026	26-147

Bill To:
<b>Novi Schools - Admin Building</b> <b>Betsy</b> <b>25345 Taft Rd.</b> <b>Novi, MI 48374</b>

Ship To
<b>Novi Meadows</b>

Customer Contact	Customer Phone	Customer Fax	Terms	P.O. No.	Rep
<b>John</b>	<b>248-255-1214</b>	<b>248-449-1249</b>	<b>Net 30</b>		<b>LAS</b>

Item	Description	Qty	Weight	Price	Total
	<b>Novi ECEC LSI Equipment with Sourcewell</b>				
<b>Playshaper S...</b>	<b>Playshaper Structure</b>	<b>1</b>		<b>24,515.70</b>	<b>24,515.70</b>
<b>223856A</b>	<b>Smart Play Nook 6-23 Month Direct Bury</b>	<b>1</b>		<b>10,842.60</b>	<b>10,842.60</b>
<b>233057B</b>	<b>DigiRider Butterfly</b>	<b>1</b>		<b>1,958.40</b>	<b>1,958.40</b>
<b>154397A</b>	<b>LSI Single Post Cool Topper</b>	<b>1</b>		<b>5,650.80</b>	<b>5,650.80</b>
<b>174018A</b>	<b>Belt Seat w/Chains ProGuard Chains for 8' Beam Height</b>	<b>6</b>		<b>178.50</b>	<b>1,071.00</b>
<b>177332A</b>	<b>Single Post Swing Frame 8' Beam Height</b>	<b>1</b>		<b>1,744.20</b>	<b>1,744.20</b>
<b>177333A</b>	<b>Single Post Swing Frame Additional 8' Bay</b>	<b>2</b>		<b>2,590.80</b>	<b>5,181.60</b>
<b>Freight</b>	<b>Freight</b>	<b>1</b>		<b>3,000.00</b>	<b>3,000.00</b>
<b>Sourcewell D...</b>	<b>Sourcewell Discount</b>			<b>-8.00%</b>	<b>-240.00</b>

Proposal Good For 30 Days  
 Shipping Time: TBD  
 Ship Via: Common Carrier  
 Please call 24 hours prior to delivery: \_\_\_\_\_

Customer signature below constitutes a purchase order.

<b>Subtotal</b>	\$53,724.30
<b>Sales Tax (0.0%)</b>	\$0.00
<b>Total</b>	\$53,724.30



Make all P.O.s, Contracts, and Checks to:  
**Penchura, L.L.C.**  
**889 S. Old US 23**  
**Brighton, MI 48114**

# Proposal

Date	Project #
2/20/2026	26-147-1

<b>Bill To</b>
Novi Schools - Admin Building Betsy 25345 Taft Rd. Novi, MI 48374

<b>Ship To</b>
Novi Meadows

<b>Customer Contact</b>	<b>Customer Phone</b>	<b>Customer Fax</b>	<b>Terms</b>	<b>P.O. No.</b>	<b>Rep</b>
John	248-255-1214	248-449-1249	Net 30		LAS

Item	Description	Qty	Weight	Price	Total
Installation	Novi Preschool Play Equipment installation and stone base ~ Receive Equipment. ~ Layout / stake site. ~ Install all playground equipment and Cool Topper Shade per the drawing #: PEN1204079-01 dated 1/19/2026	1		38,250.00	38,250.00
Installation	Professional Certified Installation ~ Furnish and install 9,511 sf of aggregate base at a 4" compacted depth.	1		30,876.00	30,876.00

Proposal good for 30 days.  
 Ship Via: common carrier  
 Delivery contact name and number: \_\_\_\_\_

Customer signature below constitutes a purchase order.

\_\_\_\_\_

<b>Subtotal</b>	\$69,126.00
<b>Sales Tax (0.0%)</b>	\$0.00
<b>Total</b>	\$69,126.00

**Credit Card fee of 3% on all payments using a CC.**  
**AMX fee of 5% on all payments using AMX**

889 S. Old US 23, Brighton, MI 48114  
 Office: (810) 229-6245 Fax: (810) 229-6256 Toll Free: (888) 778-7529



Make all P.O.s, Contracts, and Checks to:  
**Penchura, L.L.C.**  
**889 S. Old US 23**  
**Brighton, MI 48114**

# Proposal

Date	Project #
2/20/2026	26-222-1

<b>Bill To</b>
Novi Schools - Admin Building Betsy 25345 Taft Rd. Novi, MI 48374

<b>Ship To</b>
Novi Meadows

<b>Customer Contact</b>	<b>Customer Phone</b>	<b>Customer Fax</b>	<b>Terms</b>	<b>P.O. No.</b>	<b>Rep</b>
John	248-255-1214	248-449-1249	Net 30		LAS

Item	Description	Qty	Weight	Price	Total
Forever Lawn	Novi Prescholl Turf Mound Forever Lawn - Material-Safety Surfacing Includes ForeverLawn® Synthetic Grass (Playground Grass Ultra) in Green over aggregate for a max fall height of 2' including installation. This includes fine grading and minor amount of stone base and installation supplies (seam tape, glue, crumb rubber infill), product installation, mobilization and freight charges. This agreement assumes the area is close to finish grade with a minimal amount of stone base to install and compact upon the arrival of the ForeverLawn team.			82,775.00	82,775.00
	Warranty 15 Year Closed-Loop Warranty combined with 2 year installation warranty				
	Payment Terms: 50% upon acceptance of the agreement, Remaining balance due upon completion of the project.				

Proposal good for 30 days.  
 Ship Via: common carrier  
 Delivery contact name and number: \_\_\_\_\_

Customer signature below constitutes a purchase order.

\_\_\_\_\_

<b>Subtotal</b>	\$82,775.00
<b>Sales Tax (0.0%)</b>	\$0.00
<b>Total</b>	\$82,775.00

**Credit Card fee of 3% on all payments using a CC.**  
**AMX fee of 5% on all payments using AMX**

889 S. Old US 23, Brighton, MI 48114  
 Office: (810) 229-6245 Fax: (810) 229-6256 Toll Free: (888) 778-7529



The play components identified on this plan are IPEMA certified. (Unless model number is preceded with \*) The use and layout of these components conform to the requirements of ASTM F1487. To verify product certification, visit [www.ipema.org](http://www.ipema.org)

THIS PLAY AREA & PLAY EQUIPMENT IS DESIGNED FOR AGES .5-5 YEARS UNLESS OTHERWISE NOTED ON PLAN.

IT IS THE MANUFACTURERS OPINION THAT THIS PLAY AREA DOES CONFORM TO THE A.D.A. ACCESSIBILITY STANDARDS, ASSUMING AN ACCESSIBLE PROTECTIVE SURFACING IS PROVIDED, AS INDICATED, OR WITHIN THE ENTIRE USE ZONE.

THIS CONCEPTUAL PLAN WAS BASED ON INFORMATION AVAILABLE TO US. PRIOR TO CONSTRUCTION, DETAILED SITE INFORMATION INCLUDING SITE DIMENSIONS, TOPOGRAPHY EXISTING UTILITIES, SOIL CONDITIONS, AND DRAINAGE SOLUTIONS SHOULD BE OBTAINED, EVALUATED, & UTILIZED IN THE FINAL DESIGN. PLEASE VERIFY ALL DIMENSIONS OF PLAY AREA, SIZE, ORIENTATION, AND LOCATION OF ALL EXISTING UTILITIES, EQUIPMENT, AND SITE FURNISHINGS PRIOR TO ORDERING. SLIDES SHOULD NOT FACE THE HOT AFTERNOON SUN.

CHOOSE A PROTECTIVE SURFACING MATERIAL THAT HAS A CRITICAL HEIGHT VALUE TO MEET THE MAXIMUM FALL HEIGHT FOR THE EQUIPMENT (REF. ASTM F1487 STANDARD CONSUMER SAFETY PERFORMANCE SPECIFICATION FOR PLAYGROUND EQUIPMENT FOR PUBLIC USE, SECTION 8 CURRENT REVISION). THE SUBSURFACE MUST BE WELL DRAINED. IF THE SOIL DOES NOT DRAIN NATURALLY IT MUST BE TILED OR SLOPED 1/8" TO 1/4" PER FOOT TO A STORM SEWER OR A "TRENCH DRAIN".

AREA OF ACCESSIBLE/PROTECTIVE SURFACING (POURED-IN-PLACE SUGGESTED)  
3,362 SF

DESIGNED BY:  
AH

COPYRIGHT: 1/19/2026  
LANDSCAPE STRUCTURES, INC.  
601 7th STREET SOUTH - P.O. BOX 198  
DELANO, MINNESOTA 55328  
PH: 1-800-328-0035 FAX: 1-763-972-6091

Date	Previous Drawing #	Initials

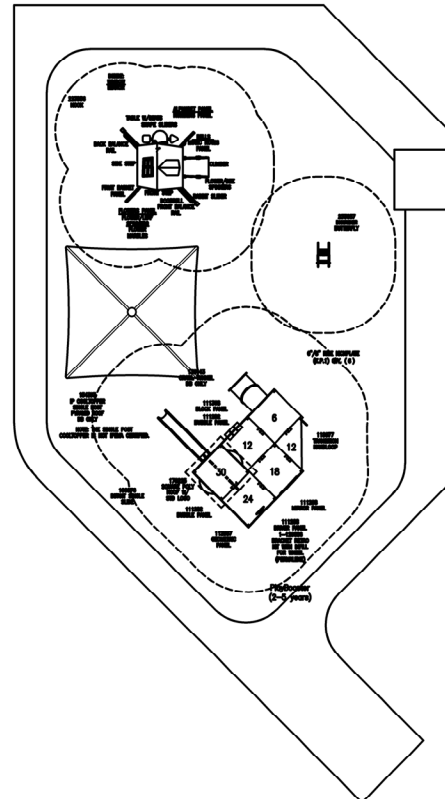

PlayShaper and Smart Play  
(0-23 months)  
Max Fall Height: 30 Inches

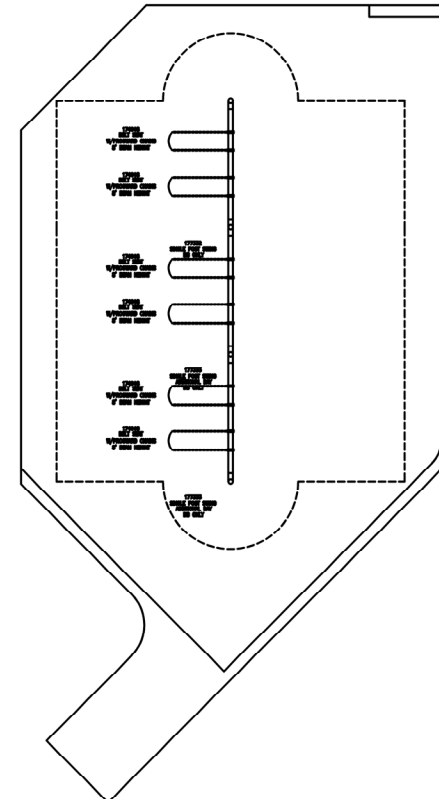

Freefloating Play  
(2-5 years)  
Max Fall Height: 60 Inches

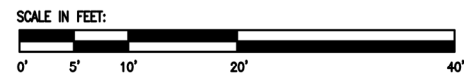

Novi Early Childhood  
Education Center  
Novi, MI

Penchura, LLC  
Lance Shipman

SYSTEM TYPE:  
PlayShaper/Smart Play

DRAWING #:  
PEN1204079-01





Novi Early Childhood Education Center

PEN1204079-01 • 1.30.2026



© 2026 Landscape Structures. All Rights Reserved



Novi Early Childhood Education Center

PEN1204079-01 • 1.30.2026





*LS* landscape  
structures

Novi Early Childhood Education Center

PEN1204079-01 • 1.30.2026





The play components identified on this plan are IPEMA certified. (Unless model number is preceded with \*) The use and layout of these components conform to the requirements of ASTM F1487. To verify product certification, visit [www.ipema.org](http://www.ipema.org)

THIS PLAY AREA & PLAY EQUIPMENT IS DESIGNED FOR AGES 5-12 YEARS UNLESS OTHERWISE NOTED ON PLAN.

IT IS THE MANUFACTURERS OPINION THAT THIS PLAY AREA DOES CONFORM TO THE A.D.A. ACCESSIBILITY STANDARDS, ASSUMING AN ACCESSIBLE PROTECTIVE SURFACING IS PROVIDED, AS INDICATED, OR WITHIN THE ENTIRE USE ZONE.

THIS CONCEPTUAL PLAN WAS BASED ON INFORMATION AVAILABLE TO US. PRIOR TO CONSTRUCTION, DETAILED SITE INFORMATION INCLUDING SITE DIMENSIONS, TOPOGRAPHY EXISTING UTILITIES, SOIL CONDITIONS, AND DRAINAGE SOLUTIONS SHOULD BE OBTAINED, EVALUATED, & UTILIZED IN THE FINAL DESIGN. PLEASE VERIFY ALL DIMENSIONS OF PLAY AREA, SIZE, ORIENTATION, AND LOCATION OF ALL EXISTING UTILITIES, EQUIPMENT, AND SITE FURNISHINGS PRIOR TO ORDERING. SLIDES SHOULD NOT FACE THE HOT AFTERNOON SUN.

CHOOSE A PROTECTIVE SURFACING MATERIAL THAT HAS A CRITICAL HEIGHT VALUE TO MEET THE MAXIMUM FALL HEIGHT FOR THE EQUIPMENT (REF. ASTM F1487 STANDARD CONSUMER SAFETY PERFORMANCE SPECIFICATION FOR PLAYGROUND EQUIPMENT FOR PUBLIC USE, SECTION 8 CURRENT REVISION). THE SUBSURFACE MUST BE WELL DRAINED. IF THE SOIL DOES NOT DRAIN NATURALLY IT MUST BE TILED OR SLOPED 1/8" TO 1/4" PER FOOT TO A STORM SEWER OR A "TRENCH DRAIN".

AREA OF ACCESSIBLE/PROTECTIVE SURFACING (POURED-IN-PLACE SUGGESTED) 8,962 SF

DESIGNED BY:  
AH

COPYRIGHT: 2/3/2026  
LANDSCAPE STRUCTURES, INC.  
601 7th STREET SOUTH - P.O. BOX 198  
DELANO, MINNESOTA 55328  
PH: 1-800-328-0035 FAX: 1-763-972-6091

Date	Previous Drawing #	Initials

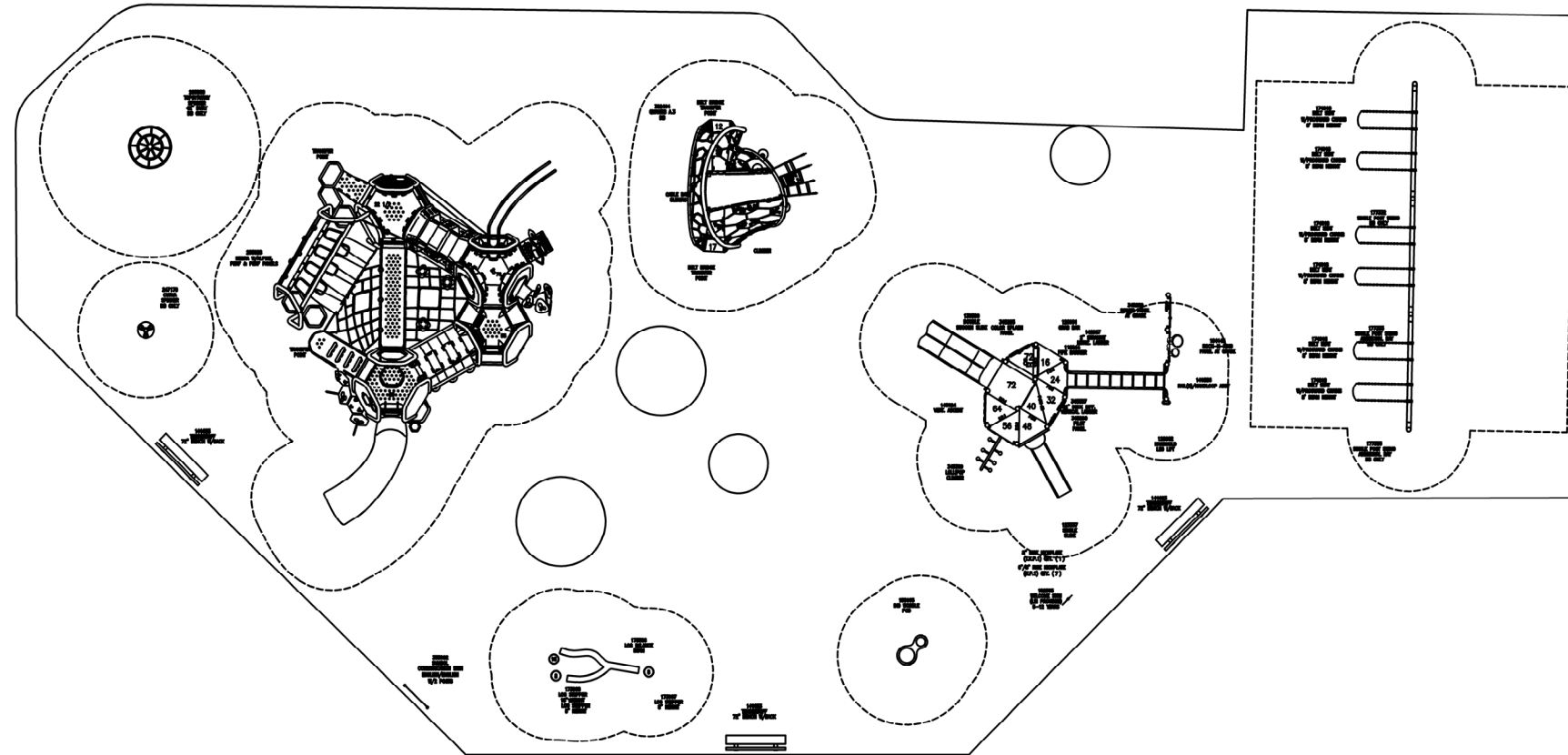

TOTAL ELEVATED PLAY COMPONENTS	22		
TOTAL ELEVATED COMPONENTS ACCESSIBLE BY RAMP	0	REQUIRED	0
TOTAL ELEVATED COMPONENTS ACCESSIBLE BY TRANSFER	17	REQUIRED	11
TOTAL ACCESSIBLE GROUND LEVEL COMPONENTS SHOWN	25	REQUIRED	7
TOTAL DIFFERENT TYPES OF GROUND LEVEL COMPONENTS	16	REQUIRED	16

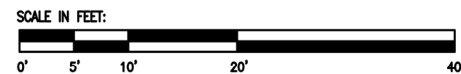

Parkview Elementary  
Middle  
Novi, MI

Penchura, LLC  
Lance Shipman

SYSTEM TYPE:  
Hedra/PlayBooster  
DRAWING #:  
PEN1204077-01-01





landscape  
structures

Parkview Elementary - Middle

PEN1204077-01-01 • 2.4.2026



© 2026 Landscape Structures. All Rights Reserved





landscape  
structures

Parkview Elementary - Middle

PEN1204077-01-01 • 2.4.2026



© 2026 Landscape Structures. All Rights Reserved



landscape structures

Parkview Elementary - Middle

PEN1204077-01-01 • 2.4.2026





Parkview Elementary - Middle

PEN1204077-01-01 • 2.4.2026





landscape structures

Parkview Elementary - Middle

PEN1204077-01-01 • 2.4.2026



© 2026 Landscape Structures. All Rights Reserved



landscape structures

Parkview Elementary - Middle

PEN1204077-01-01 • 2.4.2026



© 2026 Landscape Structures. All Rights Reserved





*LS* landscape  
structures

Parkview Elementary - Middle

PEN1204076-01-01 • 2.3.2026





*LS* landscape  
structures

Parkview Elementary - Middle

PEN1204076-01-01 • 2.3.2026



© 2026 Landscape Structures. All Rights Reserved



*LS* landscape  
structures

Parkview Elementary - Middle

PEN1204076-01-01 • 2.3.2026





*LS* landscape  
structures

Parkview Elementary - Middle

PEN1204076-01-01 • 2.3.2026



© 2026 Landscape Structures. All Rights Reserved

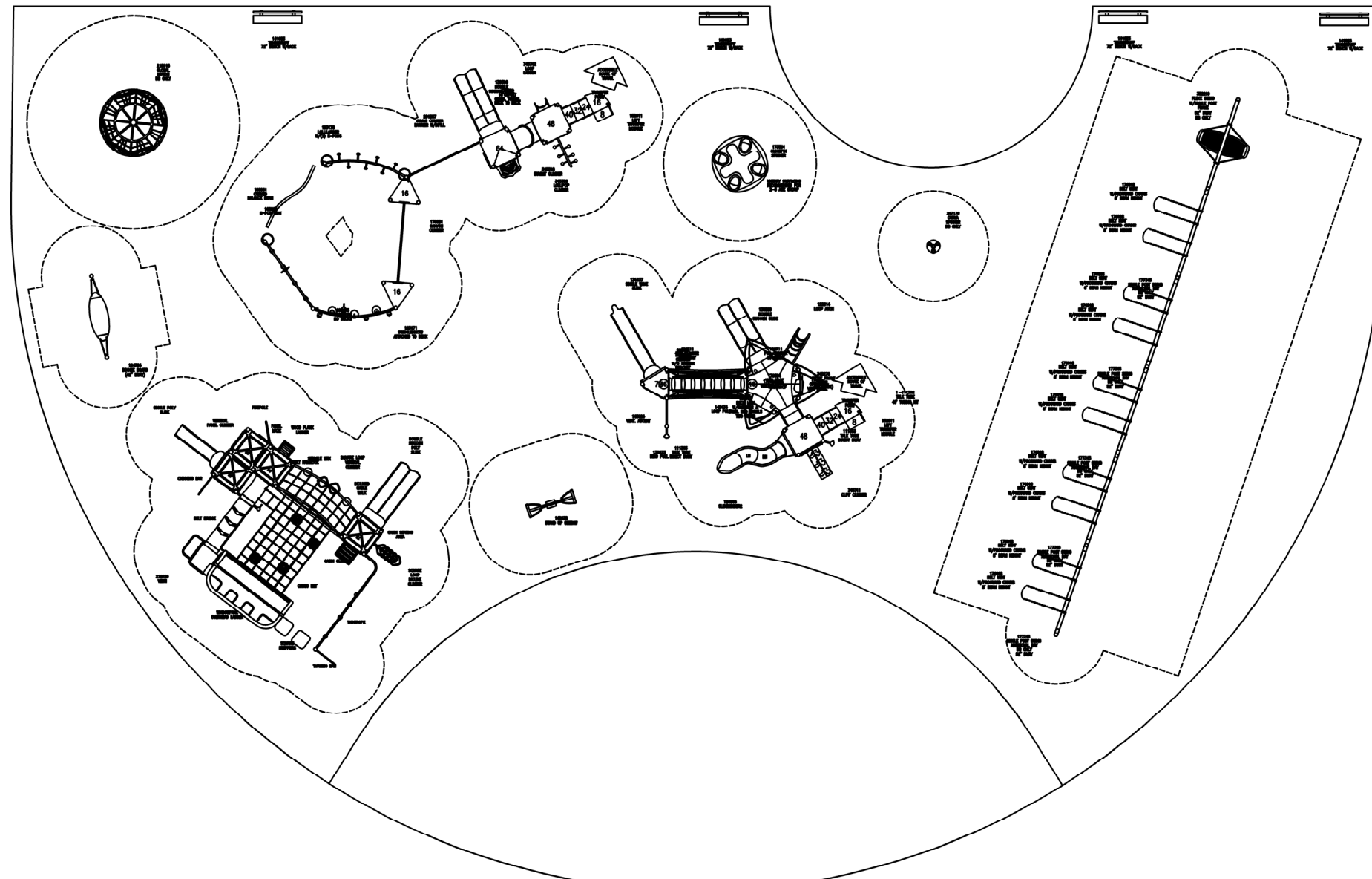

PlayBooster and Smart Play  
(5-12 years)  
Max Fall Height: 90 inches

TOTAL ELEVATED PLAY COMPONENTS	31		
TOTAL ELEVATED COMPONENTS ACCESSIBLE BY RAMP	0	REQUIRED	0
TOTAL ELEVATED COMPONENTS ACCESSIBLE BY TRANSFER	20	REQUIRED	16
TOTAL ACCESSIBLE GROUND LEVEL COMPONENTS SHOWN	29	REQUIRED	10
TOTAL DIFFERENT TYPES OF GROUND LEVEL COMPONENTS	16	REQUIRED	16

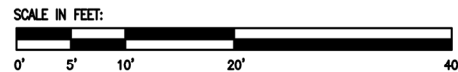

Parkview Elementary  
South  
Novi, MI

Penchura, LLC  
Lance Shipman

SYSTEM TYPE:  
PlayBooster/Smart Play  
DRAWING #:  
PEN1204078-01-01



The play components identified on this plan are IPEMA certified. (Unless model number is preceded with \*) The use and layout of these components conform to the requirements of ASTM F1487. To verify product certification, visit [www.ipema.org](http://www.ipema.org)

THIS PLAY AREA & PLAY EQUIPMENT IS DESIGNED FOR AGES 5-12 YEARS UNLESS OTHERWISE NOTED ON PLAN.

IT IS THE MANUFACTURERS OPINION THAT THIS PLAY AREA DOES NOT CONFORM TO THE A.D.A. ACCESSIBILITY STANDARDS

THIS CONCEPTUAL PLAN WAS BASED ON INFORMATION AVAILABLE TO US. PRIOR TO CONSTRUCTION, DETAILED SITE INFORMATION INCLUDING SITE DIMENSIONS, TOPOGRAPHY, EXISTING UTILITIES, SOIL CONDITIONS, AND DRAINAGE SOLUTIONS SHOULD BE OBTAINED, EVALUATED, & UTILIZED IN THE FINAL DESIGN. PLEASE VERIFY ALL DIMENSIONS OF PLAY AREA, SIZE, ORIENTATION, AND LOCATION OF ALL EXISTING UTILITIES, EQUIPMENT, AND SITE FURNISHINGS PRIOR TO ORDERING. SLIDES SHOULD NOT FACE THE HOT AFTERNOON SUN.

CHOOSE A PROTECTIVE SURFACING MATERIAL THAT HAS A CRITICAL HEIGHT VALUE TO MEET THE MAXIMUM FALL HEIGHT FOR THE EQUIPMENT (REF. ASTM F1487 STANDARD CONSUMER SAFETY PERFORMANCE SPECIFICATION FOR PLAYGROUND EQUIPMENT FOR PUBLIC USE, SECTION 8 CURRENT REVISION). THE SUBSURFACE MUST BE WELL DRAINED. IF THE SOIL DOES NOT DRAIN NATURALLY IT MUST BE TILED OR SLOPED 1/8" TO 1/4" PER FOOT TO A STORM SEWER OR A "TRENCH DRAIN".

AREA OF ACCESSIBLE/PROTECTIVE SURFACING (POURED-IN-PLACE SUGGESTED)  
12,212 SF

DESIGNED BY:  
AH

COPYRIGHT: 2/2/2026  
LANDSCAPE STRUCTURES, INC.  
601 7th STREET SOUTH - P.O. BOX 198  
DELANO, MINNESOTA 55328  
PH: 1-800-328-0035 FAX: 1-763-972-6091

Date	Previous Drawing #	Initials





landscape structures

Parkview Elementary

PEN1204078-01-01 • 2.4.2026





landscape  
structures

Parkview Elementary

PEN1204078-01-01 • 2.4.2026



© 2026 Landscape Structures. All Rights Reserved



Parkview Elementary

PEN1204078-01-01 • 2.4.2026





landscape  
structures

Parkview Elementary



PEN1204078-01-01 • 2.4.2026

© 2026 Landscape Structures. All Rights Reserved



The play components identified on this plan are IPEMA certified. (Unless model number is preceded with \*) The use and layout of these components conform to the requirements of ASTM F1487. To verify product certification, visit [www.ipema.org](http://www.ipema.org)

THIS PLAY AREA & PLAY EQUIPMENT IS DESIGNED FOR AGES 5-12 YEARS UNLESS OTHERWISE NOTED ON PLAN.

IT IS THE MANUFACTURERS OPINION THAT THIS PLAY AREA DOES CONFORM TO THE A.D.A. ACCESSIBILITY STANDARDS, ASSUMING AN ACCESSIBLE PROTECTIVE SURFACING IS PROVIDED, AS INDICATED, OR WITHIN THE ENTIRE USE ZONE.

THIS CONCEPTUAL PLAN WAS BASED ON INFORMATION AVAILABLE TO US. PRIOR TO CONSTRUCTION, DETAILED SITE INFORMATION INCLUDING SITE DIMENSIONS, TOPOGRAPHY EXISTING UTILITIES, SOIL CONDITIONS, AND DRAINAGE SOLUTIONS SHOULD BE OBTAINED, EVALUATED, & UTILIZED IN THE FINAL DESIGN. PLEASE VERIFY ALL DIMENSIONS OF PLAY AREA, SIZE, ORIENTATION, AND LOCATION OF ALL EXISTING UTILITIES, EQUIPMENT, AND SITE FURNISHINGS PRIOR TO ORDERING. SLIDES SHOULD NOT FACE THE HOT AFTERNOON SUN.

CHOOSE A PROTECTIVE SURFACING MATERIAL THAT HAS A CRITICAL HEIGHT VALUE TO MEET THE MAXIMUM FALL HEIGHT FOR THE EQUIPMENT (REF. ASTM F1487 STANDARD CONSUMER SAFETY PERFORMANCE SPECIFICATION FOR PLAYGROUND EQUIPMENT FOR PUBLIC USE, SECTION 8 CURRENT REVISION). THE SUBSURFACE MUST BE WELL DRAINED. IF THE SOIL DOES NOT DRAIN NATURALLY IT MUST BE TILED OR SLOPED 1/8" TO 1/4" PER FOOT TO A STORM SEWER OR A "TRENCH DRAIN".

AREA OF ACCESSIBLE/PROTECTIVE SURFACING (POURED-IN-PLACE SUGGESTED) 2,858 SF

DESIGNED BY:  
AH

COPYRIGHT: 1/18/2026  
LANDSCAPE STRUCTURES, INC.  
601 7th STREET SOUTH - P.O. BOX 198  
DELANO, MINNESOTA 55328  
PH: 1-800-328-0035 FAX: 1-763-972-6091

Date	Previous Drawing #	Initials

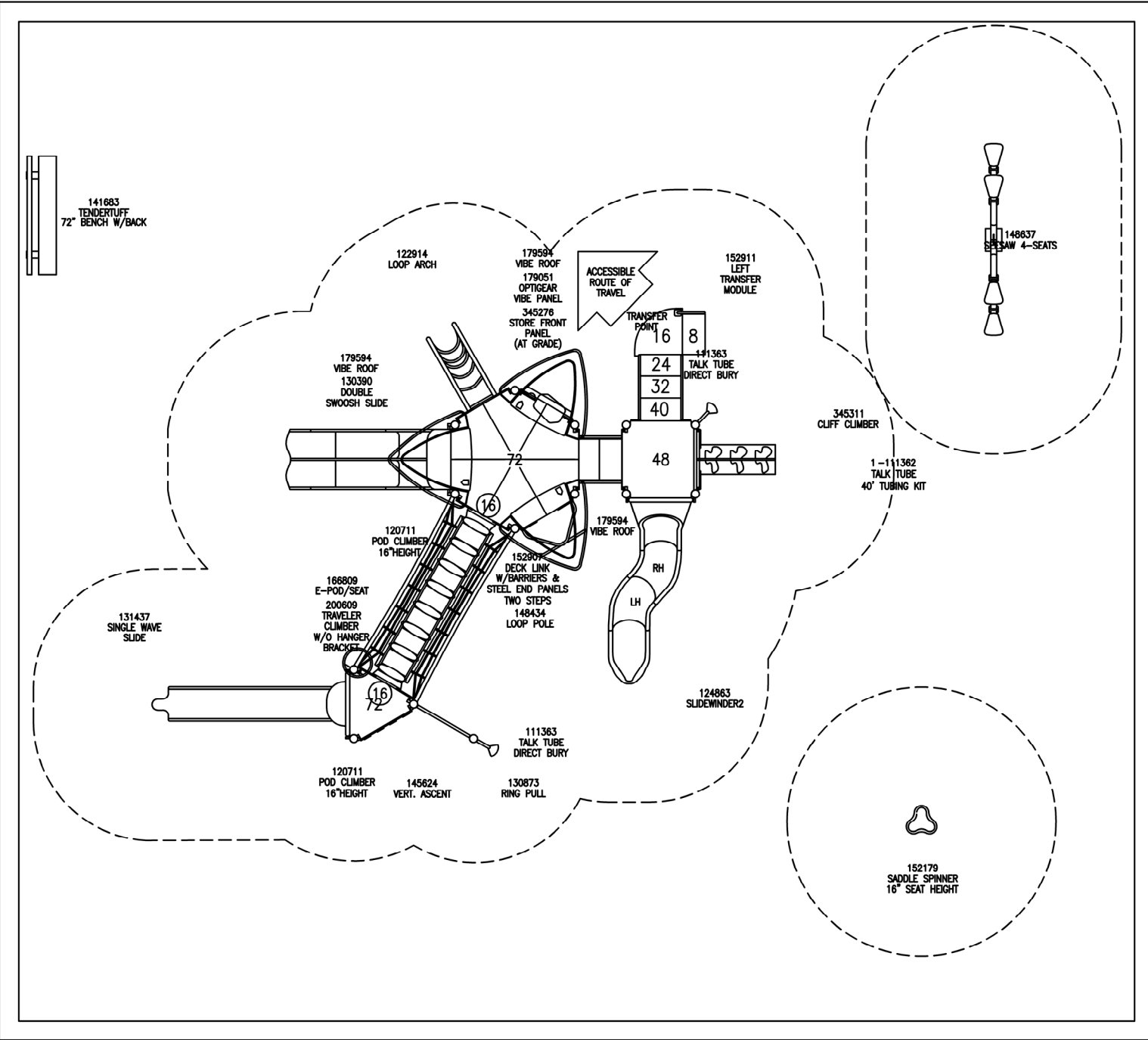

PlayBooster  
(5-12 years)  
Max Fall Height: 79 inches

TOTAL ELEVATED PLAY COMPONENTS	9		
TOTAL ELEVATED COMPONENTS ACCESSIBLE BY RAMP	0	REQUIRED	0
TOTAL ELEVATED COMPONENTS ACCESSIBLE BY TRANSFER	6	REQUIRED	5
TOTAL ACCESSIBLE GROUND LEVEL COMPONENTS SHOWN	6	REQUIRED	3
TOTAL DIFFERENT TYPES OF GROUND LEVEL COMPONENTS	6	REQUIRED	6



Novi Woods Elementary  
Lower  
Novi, MI

Penchura, LLC  
Lance Shipman

SYSTEM TYPE:  
PlayBooster  
DRAWING #:  
PEN1204082-01





*LS* landscape  
structures

Nov Woods Elementary - Lower

PEN1204082-01 • 1.18.2026





Nov Woods Elementary - Lower

PEN1204082-01 • 1.18.2026



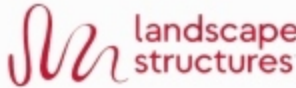

 landscape structures

Nov Woods Elementary - Lower

PEN1204082-01 • 1.18.2026

 Penchura

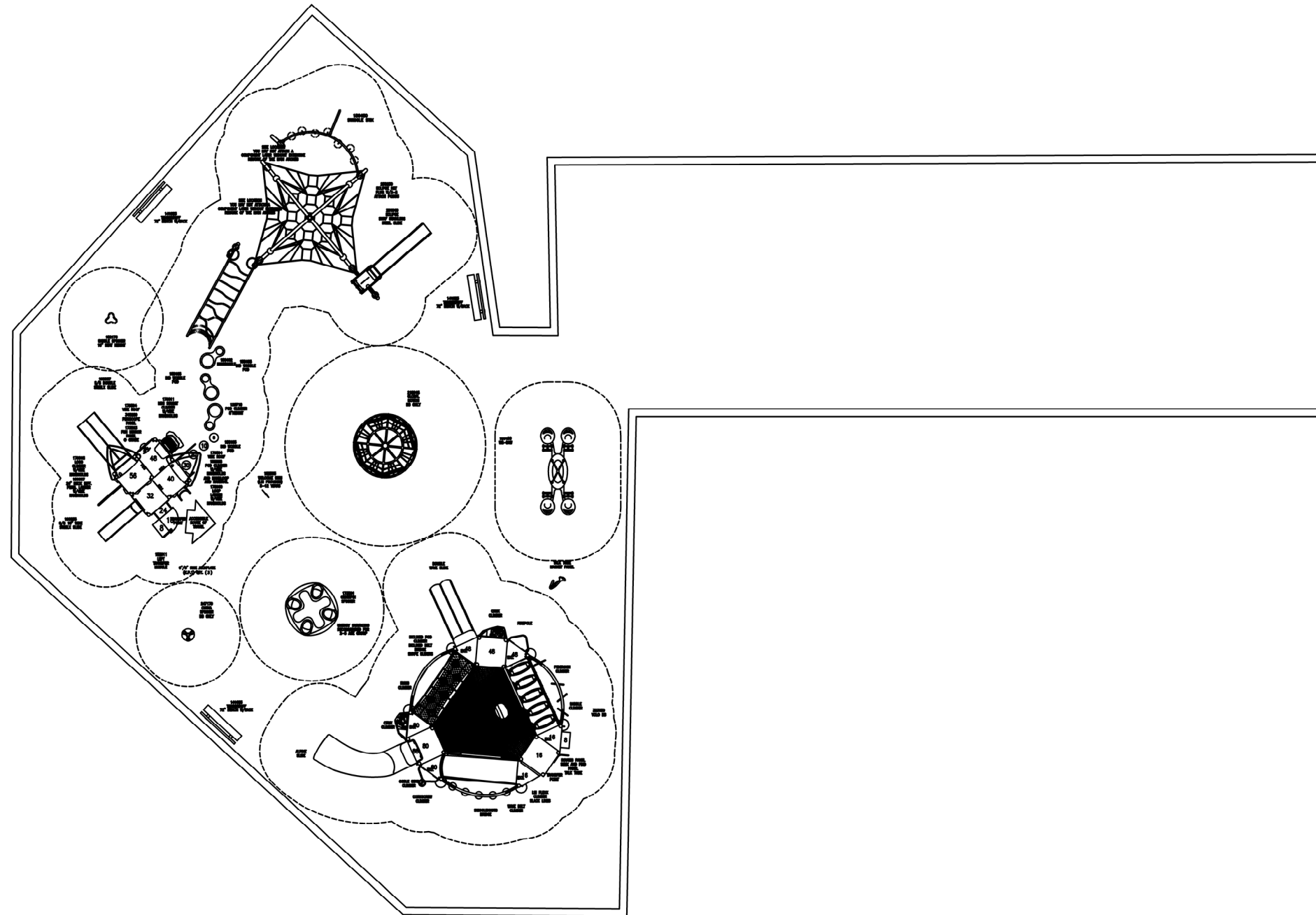

PlayStructure and Smart Play  
(5-12 years)  
Max Fall Height: 88 inches

TOTAL ELEVATED PLAY COMPONENTS	23		
TOTAL ELEVATED COMPONENTS ACCESSIBLE BY RAMP	0	REQUIRED	0
TOTAL ELEVATED COMPONENTS ACCESSIBLE BY TRANSFER	19	REQUIRED	12
TOTAL ACCESSIBLE GROUND LEVEL COMPONENTS SHOWN	19	REQUIRED	8
TOTAL DIFFERENT TYPES OF GROUND LEVEL COMPONENTS	14	REQUIRED	14

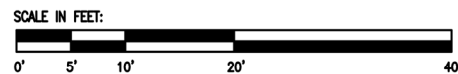

Novi Woods Elementary  
Novi, MI

Penchura, LLC  
Lance Shipman

SYSTEM TYPE:  
Evos/PB/Smart Play  
DRAWING #:  
PEN1204083-01



The play components identified on this plan are IPEMA certified. (Unless model number is preceded with \*) The use and layout of these components conform to the requirements of ASTM F1487. To verify product certification, visit [www.ipema.org](http://www.ipema.org)

THIS PLAY AREA & PLAY EQUIPMENT IS DESIGNED FOR AGES 5-12 YEARS UNLESS OTHERWISE NOTED ON PLAN.

IT IS THE MANUFACTURERS OPINION THAT THIS PLAY AREA DOES CONFORM TO THE A.D.A. ACCESSIBILITY STANDARDS, ASSUMING AN ACCESSIBLE PROTECTIVE SURFACING IS PROVIDED, AS INDICATED, OR WITHIN THE ENTIRE USE ZONE.

THIS CONCEPTUAL PLAN WAS BASED ON INFORMATION AVAILABLE TO US. PRIOR TO CONSTRUCTION, DETAILED SITE INFORMATION INCLUDING SITE DIMENSIONS, TOPOGRAPHY, EXISTING UTILITIES, SOIL CONDITIONS, AND DRAINAGE SOLUTIONS SHOULD BE OBTAINED, EVALUATED, & UTILIZED IN THE FINAL DESIGN. PLEASE VERIFY ALL DIMENSIONS OF PLAY AREA, SIZE, ORIENTATION, AND LOCATION OF ALL EXISTING UTILITIES, EQUIPMENT, AND SITE FURNISHINGS PRIOR TO ORDERING. SLIDES SHOULD NOT FACE THE HOT AFTERNOON SUN.

CHOOSE A PROTECTIVE SURFACING MATERIAL THAT HAS A CRITICAL HEIGHT VALUE TO MEET THE MAXIMUM FALL HEIGHT FOR THE EQUIPMENT (REF. ASTM F1487 STANDARD CONSUMER SAFETY PERFORMANCE SPECIFICATION FOR PLAYGROUND EQUIPMENT FOR PUBLIC USE, SECTION 8 CURRENT REVISION). THE SUBSURFACE MUST BE WELL DRAINED. IF THE SOIL DOES NOT DRAIN NATURALLY IT MUST BE TILED OR SLOPED 1/8" TO 1/4" PER FOOT TO A STORM SEWER OR A "TRENCH DRAIN".

AREA OF ACCESSIBLE/PROTECTIVE SURFACING (POURED-IN-PLACE SUGGESTED)  
9,471 SF

DESIGNED BY:  
AH

COPYRIGHT: 1/18/2026  
LANDSCAPE STRUCTURES, INC.  
601 7th STREET SOUTH - P.O. BOX 198  
DELANO, MINNESOTA 55328  
PH: 1-800-328-0035 FAX: 1-763-972-6091

Date	Previous Drawing #	Initials





Novi Woods Elementary

PEN1204083-01 • 1.18.2026





Novi Woods Elementary

PEN1204083-01 • 1.18.2026







*LS* landscape structures

Novi Woods Elementary

PEN1204083-01 • 1.18.2026



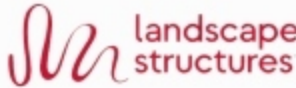

 **Novi Woods Elementary**  **Penchura**  
PEN1204083-01 • 1.18.2026



ID	Task Name	Duration	Start	Finish	% Complete	2025												2026												2027												2028												2029																																																																										
						Apr	May	Jun	Jul	Aug	Sep	Oct	Nov	Dec	Jan	Feb	Mar	Apr	May	Jun	Jul	Aug	Sep	Oct	Nov	Dec	Jan	Feb	Mar	Apr	May	Jun	Jul	Aug	Sep	Oct	Nov	Dec	Jan	Feb	Mar	Apr	May	Jun	Jul	Aug	Sep	Oct	Nov	Dec	Jan	Feb	Mar	Apr	May	Jun	Jul	Aug	Sep	Oct	Nov	Dec																																																																		
51	Construction [Summer 2026]	40 d	Mon 6/8/26	Mon 8/3/26	0%																																																													8/3																																																														
52	BPxx - HS Activity Center (NAC)	823 d	Wed 10/1/25	Thu 12/28/28	10%																																																													BPxx - HS Activity Center (NAC)																																																												10%		
53	Design	265 d	Wed 10/1/25	Thu 10/15/26	37%																																																													Design																																																												37%		
54	Early Package - Sitework, Utilities	100 d	Wed 10/1/25	Mon 2/23/26	76%																																																													Early Package - Sitework, Utilities																																																												2/23		
55	Foundations and Building Package	240 d	Wed 11/5/25	Thu 10/15/26	25%																																																													Foundations and Building Package																																																												25%		
56	Programming	75 d	Wed 11/5/25	Mon 2/23/26	68%																																																													Programming																																																												2/23		
57	SD	75 d	Fri 12/5/25	Mon 3/23/26	41%																																																													SD																																																												3/23		
58	Christman SD Estimate	15 d	Tue 3/24/26	Mon 4/13/26	0%																																																													Christman SD Estimate																																																												4/13		
59	DD	45 d	Tue 3/24/26	Tue 5/26/26	0%																																																													DD																																																												5/26		
60	Christman DD Estimate	15 d	Wed 5/27/26	Tue 6/16/26	0%																																																													Christman DD Estimate																																																												6/16		
61	CD	100 d	Wed 5/27/26	Thu 10/15/26	0%																																																													CD																																																												10/15		
62	Permits	325 d	Tue 2/24/26	Thu 6/3/27	0%																																																													Permits																																																												0%		
63	BP-o1 Permits	73 d	Tue 2/24/26	Fri 6/5/26	0%																																																													BP-o1 Permits																																																												6/5		
64	BCC	60 d	Fri 10/16/26	Wed 1/13/27	0%																																																													BCC																																																												1/13		
65	BFS	60 d	Fri 10/16/26	Wed 1/13/27	0%																																																													BFS																																																												1/13		
66	City of Novi	60 d	Fri 10/16/26	Wed 1/13/27	0%																																																													City of Novi																																																												1/13		
67	EGLE?	160 d	Fri 10/16/26	Thu 6/3/27	0%																																																													EGLE?																																																												6/3		
68	Procurement	247 d	Tue 2/24/26	Fri 2/12/27	0%																																																													Procurement																																																												0%		
69	Early Package - Sitework, Utilities	97 d	Tue 2/24/26	Fri 7/10/26	0%																																																													Early Package - Sitework, Utilities																																																												0%		
70	Prepare Bid Package Documents	10 d	Tue 2/24/26	Mon 3/9/26	0%																																																													Prepare Bid Package Documents																																																												3/9		
71	Bidding Period	10 d	Tue 3/10/26	Mon 3/23/26	0%																																																													Bidding Period																																																												3/23		
72	Bid Period Extension	5 d	Tue 3/24/26	Mon 3/30/26	0%																																																													Bid Period Extension																																																												3/30		
73	Post Bid Interviews	15 d	Tue 3/31/26	Mon 4/20/26	0%																																																													Post Bid Interviews																																																												4/20		
74	Christman Assemble Award Recommendation	10 d	Tue 4/21/26	Mon 5/4/26	0%																																																													Christman Assemble Award Recommendation																																																												5/4		
75	Christman Award Recommendation to PMR	0 d	Mon 5/4/26	Mon 5/4/26	0%																																																													Christman Award Recommendation to PMR																																																												5/4		
76	PMR Review Award Recommendation	5 d	Tue 5/5/26	Mon 5/11/26	0%																																																													PMR Review Award Recommendation																																																												5/11		
77	PMR Award Recommendation to District	0 d	Mon 5/11/26	Mon 5/11/26	0%																																																													PMR Award Recommendation to District																																																												5/11		
78	School Board First Read (June Board Meeting)	0 d	Thu 6/11/26	Thu 6/11/26	0%																																																													School Board First Read (June Board Meeting)																																																												6/11		
79	School Board Approval (July Board Meeting)	0 d	Thu 7/9/26	Thu 7/9/26	0%																																																													School Board Approval (July Board Meeting)																																																												7/9		
80	Issue Subcontracts	2 d	Thu 7/9/26	Fri 7/10/26	0%																																																													Issue Subcontracts																																																												7/10		
81	Foundations and Building Package	82 d	Fri 10/16/26	Fri 2/12/27	0%																																																													Foundations and Building Package																																																												0%		
82	Prepare Bid Package Documents	10 d	Fri 10/16/26	Thu 10/29/26	0%																																																													Prepare Bid Package Documents																																																												10/29		
83	Bidding Period	10 d	Fri 10/30/26	Thu 11/12/26	0%																																																													Bidding Period																																																												11/12		
84	Bid Period Extension	5 d	Fri 11/13/26	Thu 11/19/26	0%																																																													Bid Period Extension																																																												11/19		
85	Post Bid Interviews	15 d	Fri 11/20/26	Mon 12/14/26	0%																																																													Post Bid Interviews																																																												12/14		
86	Christman Assemble Award Recommendation	10 d	Tue 12/15/26	Tue 12/29/26	0%																																																													Christman Assemble Award Recommendation																																																												12/29		
87	Christman Award Recommendation to PMR	0 d	Tue 12/29/26	Tue 12/29/26	0%																																																													Christman Award Recommendation to PMR																																																												12/29		
88	PMR Review Award Recommendation	5 d	Wed 12/30/26	Wed 1/6/27	0%																																																													PMR Review Award Recommendation																																																												1/6		
89	PMR Award Recommendation to District	0 d	Wed 1/6/27	Wed 1/6/27	0%																																																													PMR Award Recommendation to District																																																												1/6		
90	School Board First Read (January Board Meeting)	0 d	Thu 1/14/27	Thu 1/14/27	0%																																																													School Board First Read (January Board Meeting)																																																												1/14		
91	School Board Approval (February Board Meeting)	0 d	Thu 2/11/27	Thu 2/11/27	0%																																																													School Board Approval (February Board Meeting)																																																												2/11		
92	Issue Subcontracts	2 d	Thu 2/11/27	Fri 2/12/27	0%																																																													Issue Subcontracts																																																												2/12		
93	Construction HS Activity Center	590 d	Tue 9/1/26	Thu 12/28/28	0%																																																													Construction HS Activity Center																																																												12/28		
94	BPxx - HS North Addition (Innovation Hub)	670 d	Wed 10/1/25	Fri 5/19/28	13%																																																													BPxx - HS North Addition (Innovation Hub)																																																												13%		
95	Design	225 d	Wed 10/1/25	Wed 8/19/26	38%																																																													Design																																																												38%		
96	Early Package (Utilities, Sitework, Foundations, Steel)	150 d	Wed 10/1/25	Mon 5/4/26	51%																																																													Early Package (Utilities, Sitework, Foundations, Steel)																																																												5/4		
97	Building Package	200 d	Wed 11/5/25	Wed 8/19/26	30%																																																													Building Package																																																												30%		
98	Programming	60 d	Wed 11/5/25	Mon 2/2/26	85%																																																													Programming																																																												2/2		
99	SD	60 d	Fri 12/5/25	Mon 3/2/26	52%																																																													SD																																																												3/2		
100	Christman SD Estimate	15 d	Tue 3/3/26	Mon 3/23/26	0%																																																													Christman SD Estimate																																																												3/23		
101	DD	60 d	Tue 3/3/26	Tue 5/26/26	0%																																																													DD																																																												5/26		







The play components identified on this plan are IPEMA certified. (Unless model number is preceded with \*) The use and layout of these components conform to the requirements of ASTM F1487. To verify product certification, visit [www.ipema.org](http://www.ipema.org)

THIS PLAY AREA & PLAY EQUIPMENT IS DESIGNED FOR AGES .5-5 YEARS UNLESS OTHERWISE NOTED ON PLAN.

IT IS THE MANUFACTURERS OPINION THAT THIS PLAY AREA DOES CONFORM TO THE A.D.A. ACCESSIBILITY STANDARDS, ASSUMING AN ACCESSIBLE PROTECTIVE SURFACING IS PROVIDED, AS INDICATED, OR WITHIN THE ENTIRE USE ZONE.

THIS CONCEPTUAL PLAN WAS BASED ON INFORMATION AVAILABLE TO US. PRIOR TO CONSTRUCTION, DETAILED SITE INFORMATION INCLUDING SITE DIMENSIONS, TOPOGRAPHY EXISTING UTILITIES, SOIL CONDITIONS, AND DRAINAGE SOLUTIONS SHOULD BE OBTAINED, EVALUATED, & UTILIZED IN THE FINAL DESIGN. PLEASE VERIFY ALL DIMENSIONS OF PLAY AREA, SIZE, ORIENTATION, AND LOCATION OF ALL EXISTING UTILITIES, EQUIPMENT, AND SITE FURNISHINGS PRIOR TO ORDERING. SLIDES SHOULD NOT FACE THE HOT AFTERNOON SUN.

CHOOSE A PROTECTIVE SURFACING MATERIAL THAT HAS A CRITICAL HEIGHT VALUE TO MEET THE MAXIMUM FALL HEIGHT FOR THE EQUIPMENT (REF. ASTM F1487 STANDARD CONSUMER SAFETY PERFORMANCE SPECIFICATION FOR PLAYGROUND EQUIPMENT FOR PUBLIC USE, SECTION 8 CURRENT REVISION). THE SUBSURFACE MUST BE WELL DRAINED. IF THE SOIL DOES NOT DRAIN NATURALLY IT MUST BE TILED OR SLOPED 1/8" TO 1/4" PER FOOT TO A STORM SEWER OR A "TRENCH DRAIN".

AREA OF ACCESSIBLE/PROTECTIVE SURFACING (POURED-IN-PLACE SUGGESTED)  
3,362 SF

DESIGNED BY:  
AH

COPYRIGHT: 1/19/2026  
LANDSCAPE STRUCTURES, INC.  
601 7th STREET SOUTH - P.O. BOX 198  
DELANO, MINNESOTA 55328  
PH: 1-800-328-0035 FAX: 1-763-972-6091

Date	Previous Drawing #	Initials

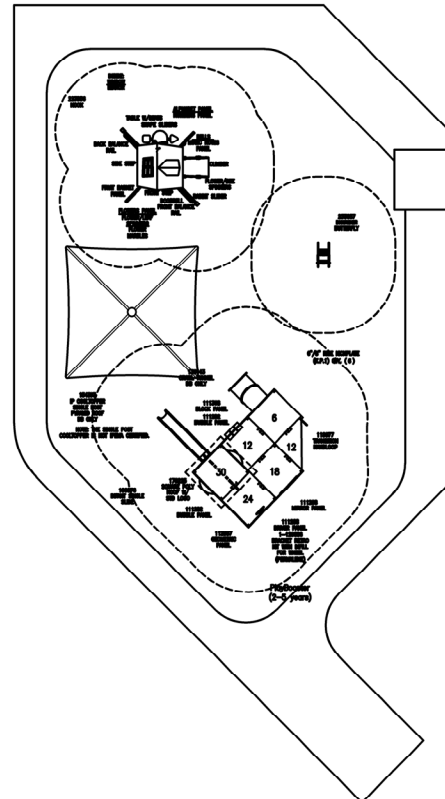

PlayShaper and Smart Play  
(0-22 months)  
Max Fall Height: 30 Inches

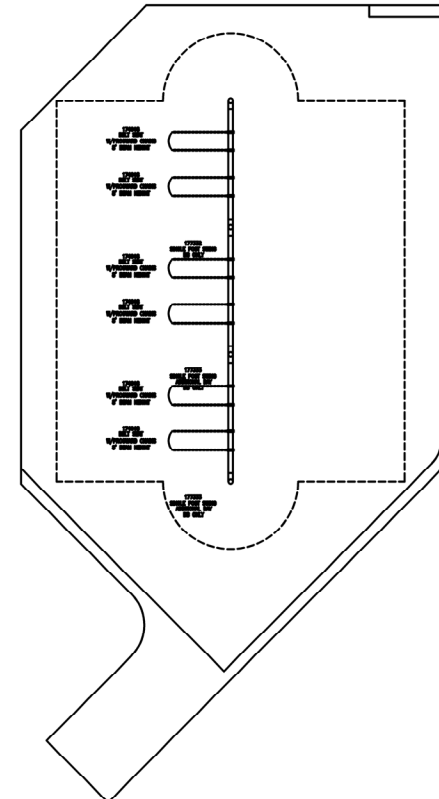

Freekicking Play  
(2-5 years)  
Max Fall Height: 60 Inches

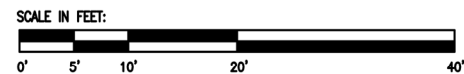

Novi Early Childhood  
Education Center  
Novi, MI

Penchura, LLC  
Lance Shipman

SYSTEM TYPE:  
PlayShaper/Smart Play  
DRAWING #:  
PEN1204079-01





Novi Early Childhood Education Center

PEN1204079-01 • 1.30.2026



© 2026 Landscape Structures. All Rights Reserved



Novi Early Childhood Education Center

PEN1204079-01 • 1.30.2026





*LS* landscape  
structures

Novi Early Childhood Education Center

PEN1204079-01 • 1.30.2026





The play components identified on this plan are IPEMA certified. (Unless model number is preceded with \*) The use and layout of these components conform to the requirements of ASTM F1487. To verify product certification, visit [www.ipema.org](http://www.ipema.org)

THIS PLAY AREA & PLAY EQUIPMENT IS DESIGNED FOR AGES 5-12 YEARS UNLESS OTHERWISE NOTED ON PLAN.

IT IS THE MANUFACTURERS OPINION THAT THIS PLAY AREA DOES CONFORM TO THE A.D.A. ACCESSIBILITY STANDARDS, ASSUMING AN ACCESSIBLE PROTECTIVE SURFACING IS PROVIDED, AS INDICATED, OR WITHIN THE ENTIRE USE ZONE.

THIS CONCEPTUAL PLAN WAS BASED ON INFORMATION AVAILABLE TO US. PRIOR TO CONSTRUCTION, DETAILED SITE INFORMATION INCLUDING SITE DIMENSIONS, TOPOGRAPHY EXISTING UTILITIES, SOIL CONDITIONS, AND DRAINAGE SOLUTIONS SHOULD BE OBTAINED, EVALUATED, & UTILIZED IN THE FINAL DESIGN. PLEASE VERIFY ALL DIMENSIONS OF PLAY AREA, SIZE, ORIENTATION, AND LOCATION OF ALL EXISTING UTILITIES, EQUIPMENT, AND SITE FURNISHINGS PRIOR TO ORDERING. SLIDES SHOULD NOT FACE THE HOT AFTERNOON SUN.

CHOOSE A PROTECTIVE SURFACING MATERIAL THAT HAS A CRITICAL HEIGHT VALUE TO MEET THE MAXIMUM FALL HEIGHT FOR THE EQUIPMENT (REF. ASTM F1487 STANDARD CONSUMER SAFETY PERFORMANCE SPECIFICATION FOR PLAYGROUND EQUIPMENT FOR PUBLIC USE, SECTION 8 CURRENT REVISION). THE SUBSURFACE MUST BE WELL DRAINED. IF THE SOIL DOES NOT DRAIN NATURALLY IT MUST BE TILED OR SLOPED 1/8" TO 1/4" PER FOOT TO A STORM SEWER OR A "TRENCH DRAIN".

AREA OF ACCESSIBLE/PROTECTIVE SURFACING (POURED-IN-PLACE SUGGESTED)  
8,962 SF

DESIGNED BY:  
AH

COPYRIGHT: 2/3/2026  
LANDSCAPE STRUCTURES, INC.  
601 7th STREET SOUTH - P.O. BOX 198  
DELANO, MINNESOTA 55328  
PH: 1-800-328-0035 FAX: 1-763-972-6091

Date	Previous Drawing #	Initials

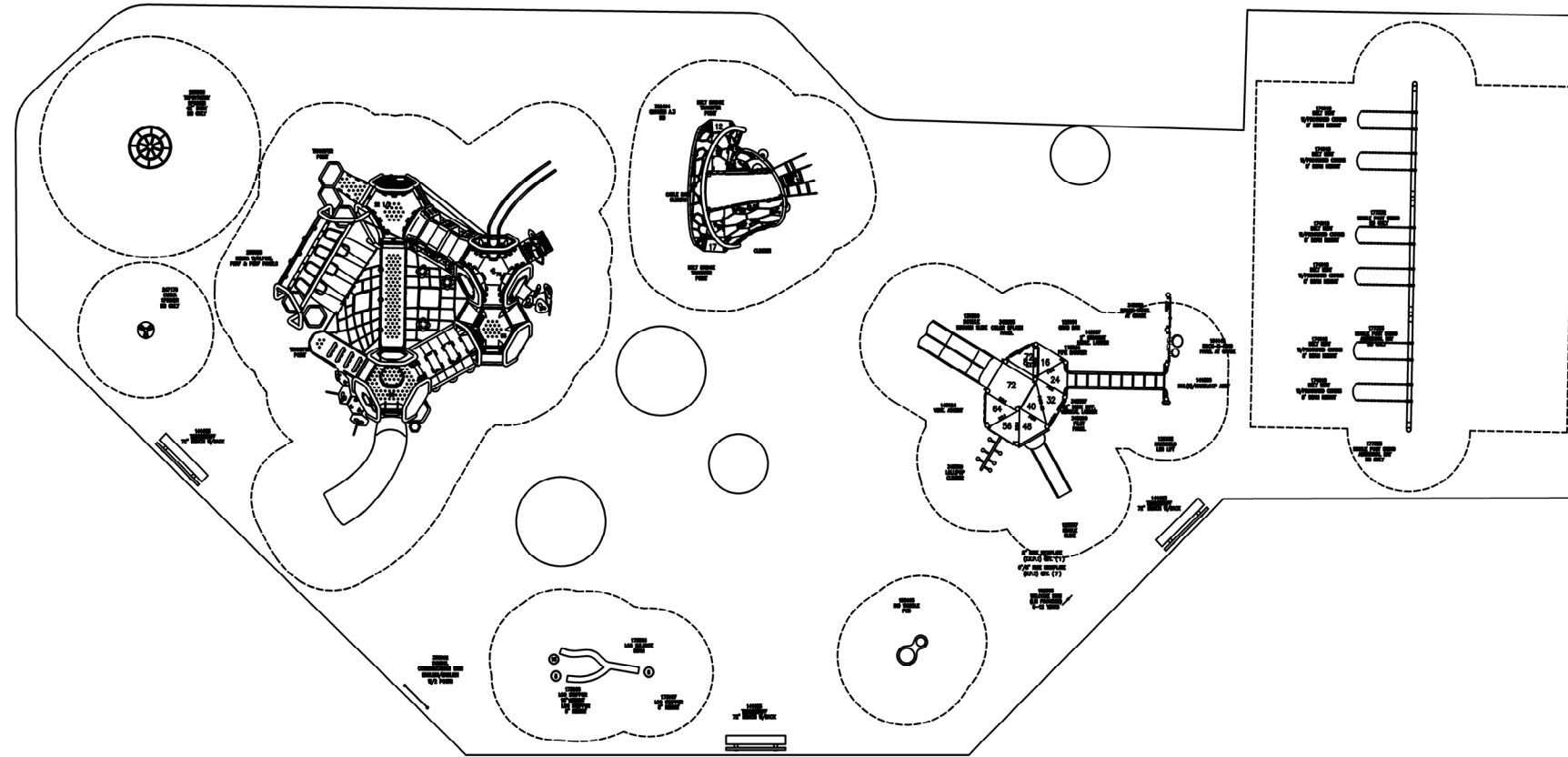

TOTAL ELEVATED PLAY COMPONENTS	22		
TOTAL ELEVATED COMPONENTS ACCESSIBLE BY RAMP	0	REQUIRED	0
TOTAL ELEVATED COMPONENTS ACCESSIBLE BY TRANSFER	17	REQUIRED	11
TOTAL ACCESSIBLE GROUND LEVEL COMPONENTS SHOWN	25	REQUIRED	7
TOTAL DIFFERENT TYPES OF GROUND LEVEL COMPONENTS	16	REQUIRED	16



Parkview Elementary  
Middle  
Novi, MI

Penchura, LLC  
Lance Shipman

SYSTEM TYPE:  
Hedra/PlayBooster  
DRAWING #:  
PEN1204077-01-01





landscape  
structures

Parkview Elementary - Middle

PEN1204077-01-01 • 2.4.2026



© 2026 Landscape Structures. All Rights Reserved





landscape  
structures

Parkview Elementary - Middle

PEN1204077-01-01 • 2.4.2026



© 2026 Landscape Structures. All Rights Reserved





Parkview Elementary - Middle

PEN1204077-01-01 • 2.4.2026





landscape  
structures

Parkview Elementary - Middle

PEN1204077-01-01 • 2.4.2026



© 2026 Landscape Structures. All Rights Reserved



landscape structures

Parkview Elementary - Middle

PEN1204077-01-01 • 2.4.2026



© 2026 Landscape Structures. All Rights Reserved



The play components identified on this plan are IPEMA certified. (Unless model number is preceded with \*) The use and layout of these components conform to the requirements of ASTM F1487. To verify product certification, visit [www.ipema.org](http://www.ipema.org)

THIS PLAY AREA & PLAY EQUIPMENT IS DESIGNED FOR AGES 5-12 YEARS UNLESS OTHERWISE NOTED ON PLAN.

IT IS THE MANUFACTURER'S OPINION THAT THIS PLAY AREA DOES CONFORM TO THE A.D.A. ACCESSIBILITY STANDARDS, ASSUMING AN ACCESSIBLE PROTECTIVE SURFACING IS PROVIDED, AS INDICATED, OR WITHIN THE ENTIRE USE ZONE.

THIS CONCEPTUAL PLAN WAS BASED ON INFORMATION AVAILABLE TO US. PRIOR TO CONSTRUCTION, DETAILED SITE INFORMATION INCLUDING SITE DIMENSIONS, TOPOGRAPHY EXISTING UTILITIES, SOIL CONDITIONS, AND DRAINAGE SOLUTIONS SHOULD BE OBTAINED, EVALUATED, & UTILIZED IN THE FINAL DESIGN. PLEASE VERIFY ALL DIMENSIONS OF PLAY AREA, SIZE, ORIENTATION, AND LOCATION OF ALL EXISTING UTILITIES, EQUIPMENT, AND SITE FURNISHINGS PRIOR TO ORDERING. SLIDES SHOULD NOT FACE THE HOT AFTERNOON SUN.

CHOOSE A PROTECTIVE SURFACING MATERIAL THAT HAS A CRITICAL HEIGHT VALUE TO MEET THE MAXIMUM FALL HEIGHT FOR THE EQUIPMENT (REF. ASTM F1487 STANDARD CONSUMER SAFETY PERFORMANCE SPECIFICATION FOR PLAYGROUND EQUIPMENT FOR PUBLIC USE, SECTION 8 CURRENT REVISION). THE SUBSURFACE MUST BE WELL DRAINED. IF THE SOIL DOES NOT DRAIN NATURALLY IT MUST BE TILED OR SLOPED 1/8" TO 1/4" PER FOOT TO A STORM SEWER OR A "TRENCH DRAIN".

AREA OF ACCESSIBLE/PROTECTIVE SURFACING (POURED-IN-PLACE SUGGESTED) 6,574 SF

DESIGNED BY: AH

COPYRIGHT: 2/3/2026  
LANDSCAPE STRUCTURES, INC.  
601 7th STREET SOUTH - P.O. BOX 198  
DELANO, MINNESOTA 55328  
PH: 1-800-328-0035 FAX: 1-763-972-6091

Date	Previous Drawing #	Initials

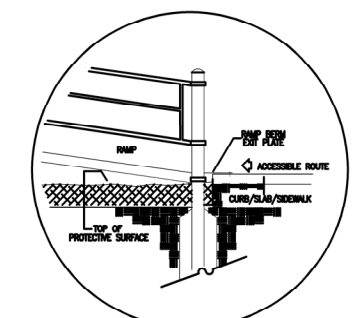
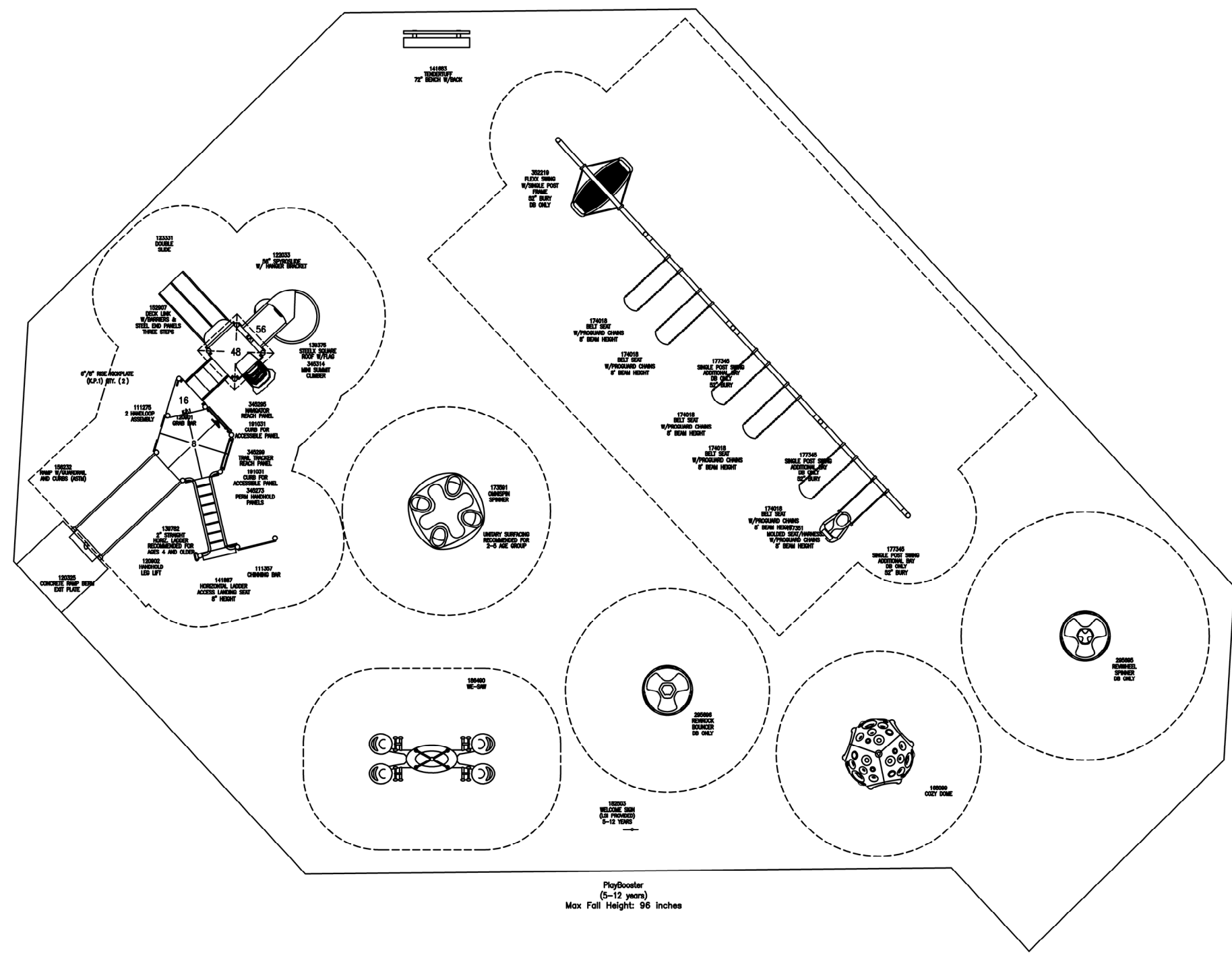

SUGGESTED RAMP BERM EXIT PLATE 8"/12"/16" DECK TO GRADE/DB INSTALLATION REFER TO RAMP BERM EXIT PLATE INSTALLATION SHEET

TOTAL ELEVATED PLAY COMPONENTS	6		
TOTAL ELEVATED COMPONENTS ACCESSIBLE BY RAMP	3	REQUIRED	0
TOTAL ELEVATED COMPONENTS ACCESSIBLE BY TRANSFER	6	REQUIRED	3
TOTAL ACCESSIBLE GROUND LEVEL COMPONENTS SHOWN	12	REQUIRED	2
TOTAL DIFFERENT TYPES OF GROUND LEVEL COMPONENTS	6	REQUIRED	6

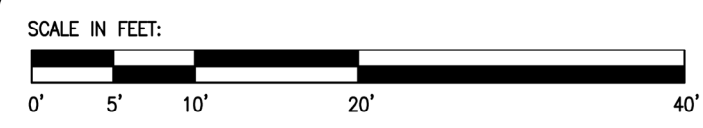

Parkview Elementary  
North  
Novi, MI

Penchura, LLC  
Lance Shipman

SYSTEM TYPE:  
PlayBooster  
DRAWING #:  
PEN1204076-01-01





*LS* landscape structures

Parkview Elementary - Middle

PEN1204076-01-01 • 2.3.2026





*LS* landscape  
structures

Parkview Elementary - Middle

PEN1204076-01-01 • 2.3.2026



© 2026 Landscape Structures. All Rights Reserved



landscape  
structures

Parkview Elementary - Middle

PEN1204076-01-01 • 2.3.2026





*LS* landscape  
structures

Parkview Elementary - Middle

PEN1204076-01-01 • 2.3.2026



© 2026 Landscape Structures. All Rights Reserved

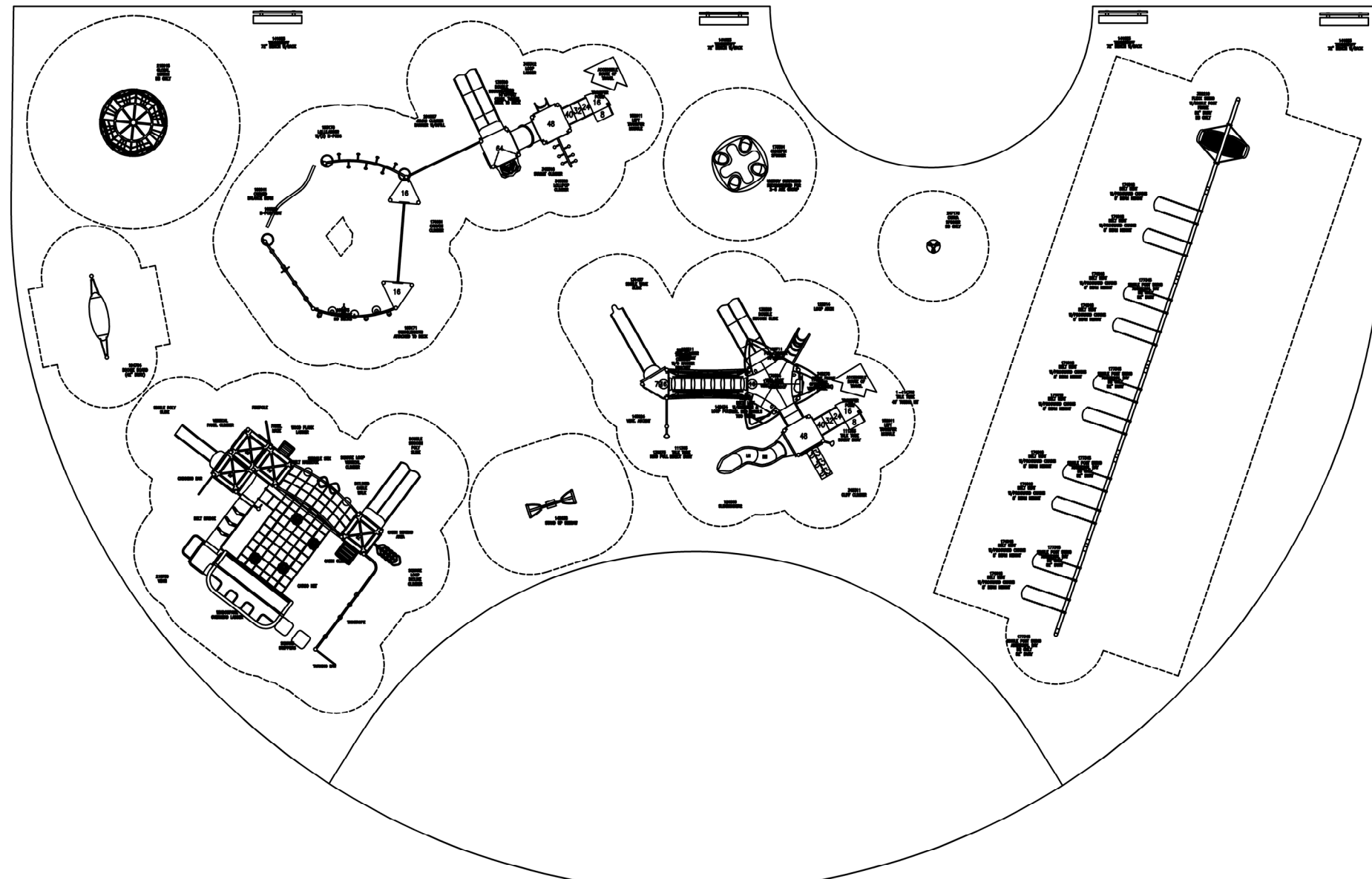

PlayBooster and Smart Play  
(5-12 years)  
Max Fall Height: 90 inches

TOTAL ELEVATED PLAY COMPONENTS	31		
TOTAL ELEVATED COMPONENTS ACCESSIBLE BY RAMP	0	REQUIRED	0
TOTAL ELEVATED COMPONENTS ACCESSIBLE BY TRANSFER	20	REQUIRED	16
TOTAL ACCESSIBLE GROUND LEVEL COMPONENTS SHOWN	29	REQUIRED	10
TOTAL DIFFERENT TYPES OF GROUND LEVEL COMPONENTS	16	REQUIRED	16

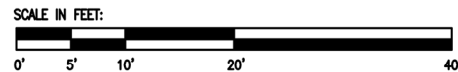

Parkview Elementary  
South  
Novi, MI

Penchura, LLC  
Lance Shipman

SYSTEM TYPE:  
PlayBooster/Smart Play  
DRAWING #:  
PEN1204078-01-01



The play components identified on this plan are IPEMA certified. (Unless model number is preceded with \*) The use and layout of these components conform to the requirements of ASTM F1487. To verify product certification, visit [www.ipema.org](http://www.ipema.org)

THIS PLAY AREA & PLAY EQUIPMENT IS DESIGNED FOR AGES 5-12 YEARS UNLESS OTHERWISE NOTED ON PLAN.

IT IS THE MANUFACTURERS OPINION THAT THIS PLAY AREA DOES NOT CONFORM TO THE A.D.A. ACCESSIBILITY STANDARDS

THIS CONCEPTUAL PLAN WAS BASED ON INFORMATION AVAILABLE TO US. PRIOR TO CONSTRUCTION, DETAILED SITE INFORMATION INCLUDING SITE DIMENSIONS, TOPOGRAPHY, EXISTING UTILITIES, SOIL CONDITIONS, AND DRAINAGE SOLUTIONS SHOULD BE OBTAINED, EVALUATED, & UTILIZED IN THE FINAL DESIGN. PLEASE VERIFY ALL DIMENSIONS OF PLAY AREA, SIZE, ORIENTATION, AND LOCATION OF ALL EXISTING UTILITIES, EQUIPMENT, AND SITE FURNISHINGS PRIOR TO ORDERING. SLIDES SHOULD NOT FACE THE HOT AFTERNOON SUN.

CHOOSE A PROTECTIVE SURFACING MATERIAL THAT HAS A CRITICAL HEIGHT VALUE TO MEET THE MAXIMUM FALL HEIGHT FOR THE EQUIPMENT (REF. ASTM F1487 STANDARD CONSUMER SAFETY PERFORMANCE SPECIFICATION FOR PLAYGROUND EQUIPMENT FOR PUBLIC USE, SECTION 8 CURRENT REVISION). THE SUBSURFACE MUST BE WELL DRAINED. IF THE SOIL DOES NOT DRAIN NATURALLY IT MUST BE TILED OR SLOPED 1/8" TO 1/4" PER FOOT TO A STORM SEWER OR A "TRENCH DRAIN".

AREA OF ACCESSIBLE/PROTECTIVE SURFACING (POURED-IN-PLACE SUGGESTED)  
12,212 SF

DESIGNED BY:  
AH

COPYRIGHT: 2/2/2026  
LANDSCAPE STRUCTURES, INC.  
601 7th STREET SOUTH - P.O. BOX 198  
DELANO, MINNESOTA 55328  
PH: 1-800-328-0035 FAX: 1-763-972-6091

Date	Previous Drawing #	Initials





landscape  
structures

Parkview Elementary

PEN1204078-01-01 • 2.4.2026



© 2026 Landscape Structures. All Rights Reserved



landscape  
structures

Parkview Elementary

PEN1204078-01-01 • 2.4.2026



© 2026 Landscape Structures. All Rights Reserved



Parkview Elementary

PEN1204078-01-01 • 2.4.2026





*LS* landscape  
structures

Parkview Elementary

PEN1204078-01-01 • 2.4.2026





The play components identified on this plan are IPEMA certified. (Unless model number is preceded with \*) The use and layout of these components conform to the requirements of ASTM F1487. To verify product certification, visit [www.ipema.org](http://www.ipema.org)

THIS PLAY AREA & PLAY EQUIPMENT IS DESIGNED FOR AGES 5-12 YEARS UNLESS OTHERWISE NOTED ON PLAN.

IT IS THE MANUFACTURERS OPINION THAT THIS PLAY AREA DOES CONFORM TO THE A.D.A. ACCESSIBILITY STANDARDS, ASSUMING AN ACCESSIBLE PROTECTIVE SURFACING IS PROVIDED, AS INDICATED, OR WITHIN THE ENTIRE USE ZONE.

THIS CONCEPTUAL PLAN WAS BASED ON INFORMATION AVAILABLE TO US. PRIOR TO CONSTRUCTION, DETAILED SITE INFORMATION INCLUDING SITE DIMENSIONS, TOPOGRAPHY EXISTING UTILITIES, SOIL CONDITIONS, AND DRAINAGE SOLUTIONS SHOULD BE OBTAINED, EVALUATED, & UTILIZED IN THE FINAL DESIGN. PLEASE VERIFY ALL DIMENSIONS OF PLAY AREA, SIZE, ORIENTATION, AND LOCATION OF ALL EXISTING UTILITIES, EQUIPMENT, AND SITE FURNISHINGS PRIOR TO ORDERING. SLIDES SHOULD NOT FACE THE HOT AFTERNOON SUN.

CHOOSE A PROTECTIVE SURFACING MATERIAL THAT HAS A CRITICAL HEIGHT VALUE TO MEET THE MAXIMUM FALL HEIGHT FOR THE EQUIPMENT (REF. ASTM F1487 STANDARD CONSUMER SAFETY PERFORMANCE SPECIFICATION FOR PLAYGROUND EQUIPMENT FOR PUBLIC USE, SECTION 8 CURRENT REVISION). THE SUBSURFACE MUST BE WELL DRAINED. IF THE SOIL DOES NOT DRAIN NATURALLY IT MUST BE TILED OR SLOPED 1/8" TO 1/4" PER FOOT TO A STORM SEWER OR A "TRENCH DRAIN".

AREA OF ACCESSIBLE/PROTECTIVE SURFACING (POURED-IN-PLACE SUGGESTED)  
2,858 SF

DESIGNED BY:  
AH

COPYRIGHT: 1/18/2026  
LANDSCAPE STRUCTURES, INC.  
601 7th STREET SOUTH - P.O. BOX 198  
DELANO, MINNESOTA 55328  
PH: 1-800-328-0035 FAX: 1-763-972-6091

Date	Previous Drawing #	Initials

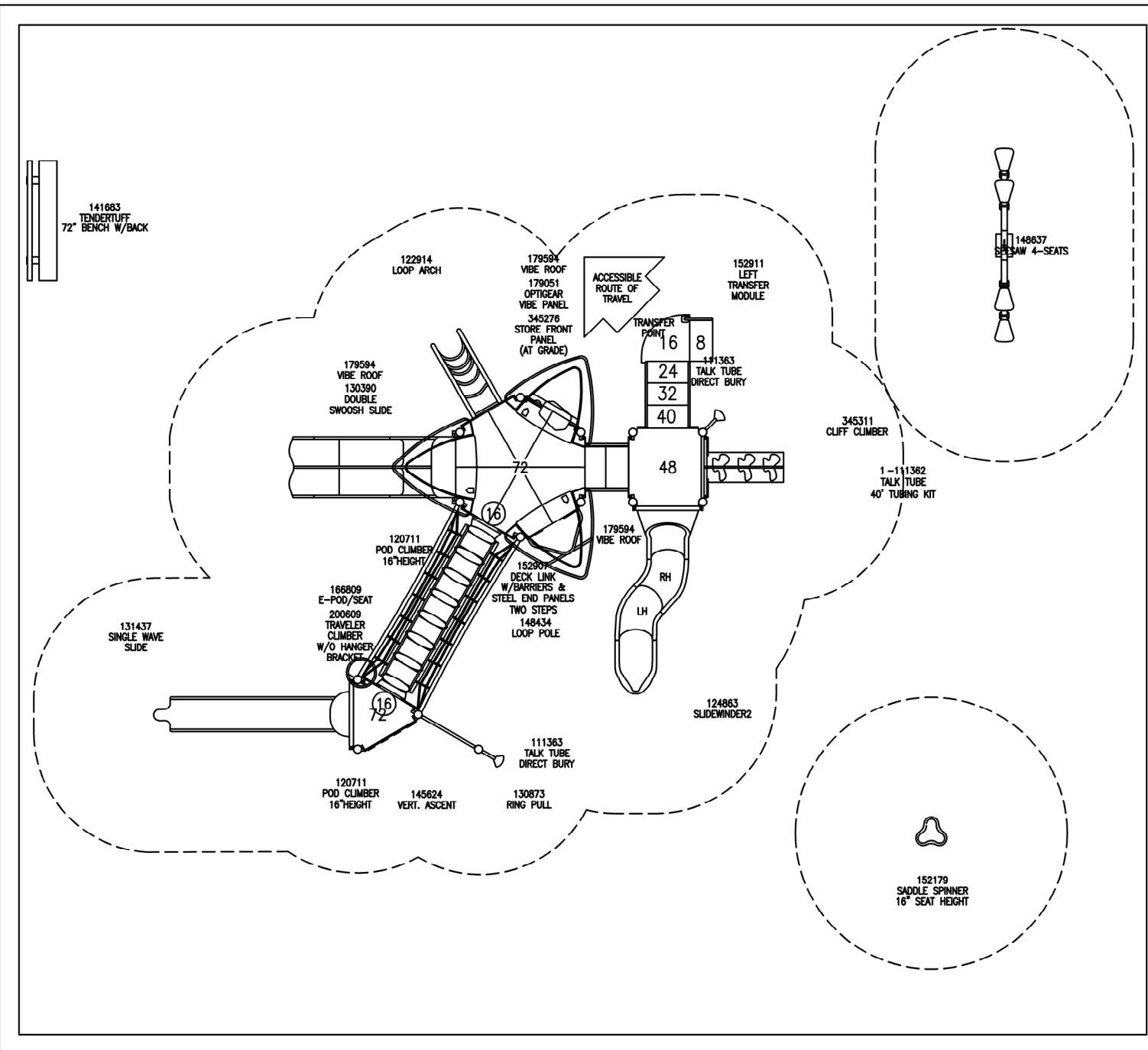

PlayBooster  
(5-12 years)  
Max Fall Height: 79 inches

TOTAL ELEVATED PLAY COMPONENTS	9		
TOTAL ELEVATED COMPONENTS ACCESSIBLE BY RAMP	0	REQUIRED	0
TOTAL ELEVATED COMPONENTS ACCESSIBLE BY TRANSFER	6	REQUIRED	5
TOTAL ACCESSIBLE GROUND LEVEL COMPONENTS SHOWN	6	REQUIRED	3
TOTAL DIFFERENT TYPES OF GROUND LEVEL COMPONENTS	6	REQUIRED	6

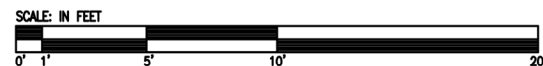

Novi Woods Elementary  
Lower  
Novi, MI

Penchura, LLC  
Lance Shipman

SYSTEM TYPE:  
PlayBooster  
DRAWING #:  
PEN1204082-01





Nov Woods Elementary - Lower

PEN1204082-01 • 1.18.2026





Nov Woods Elementary - Lower

PEN1204082-01 • 1.18.2026





*LS* landscape structures

Nov Woods Elementary - Lower

PEN1204082-01 • 1.18.2026



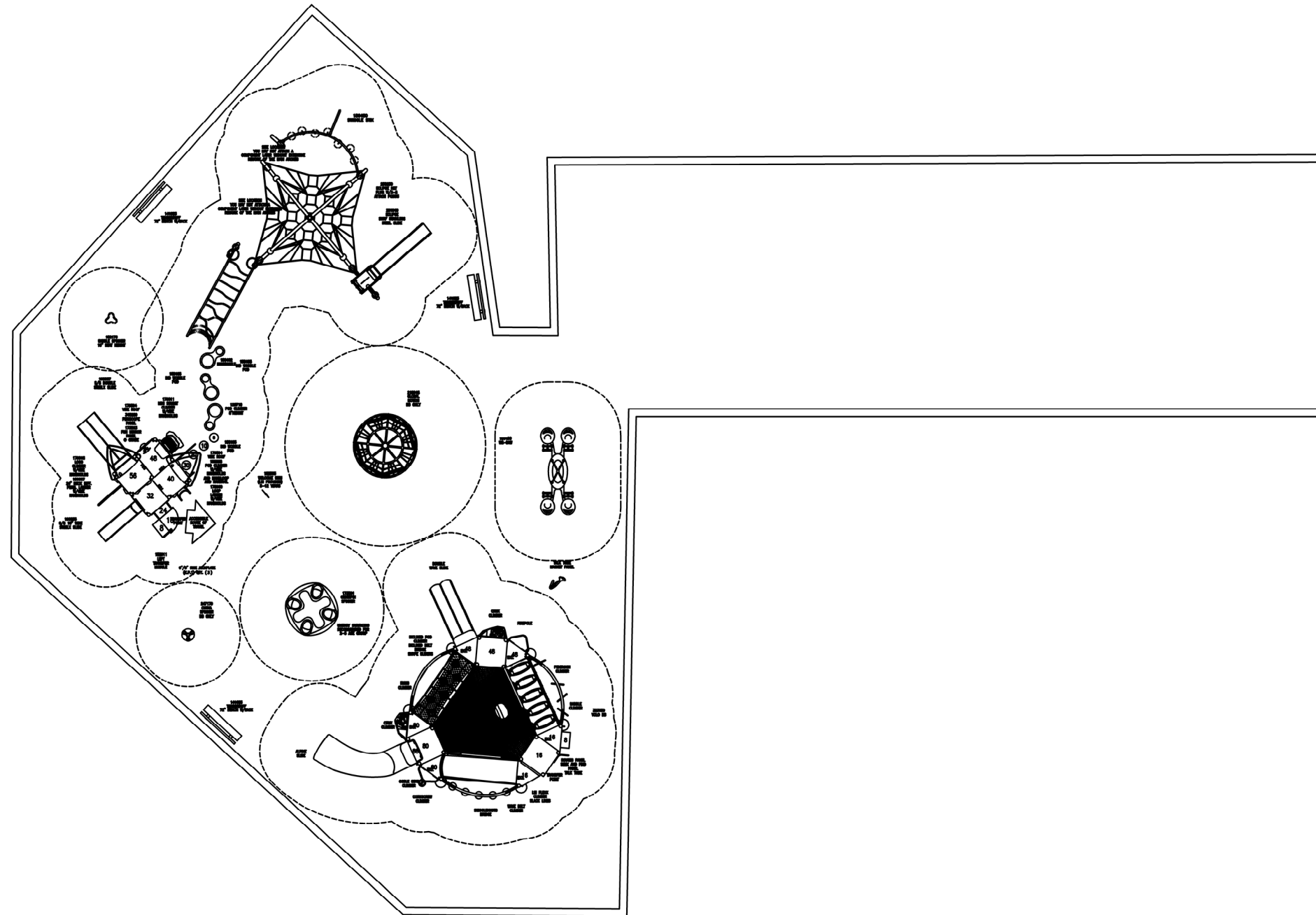

PlayStructure and Smart Play  
(5-12 years)  
Max Fall Height: 88 inches

TOTAL ELEVATED PLAY COMPONENTS	23		
TOTAL ELEVATED COMPONENTS ACCESSIBLE BY RAMP	0	REQUIRED	0
TOTAL ELEVATED COMPONENTS ACCESSIBLE BY TRANSFER	19	REQUIRED	12
TOTAL ACCESSIBLE GROUND LEVEL COMPONENTS SHOWN	19	REQUIRED	8
TOTAL DIFFERENT TYPES OF GROUND LEVEL COMPONENTS	14	REQUIRED	14

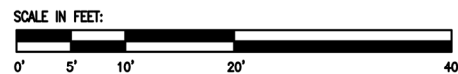

Novi Woods Elementary  
Novi, MI

Penchura, LLC  
Lance Shipman

SYSTEM TYPE:  
Evos/PB/Smart Play  
DRAWING #:  
PEN1204083-01



The play components identified on this plan are IPEMA certified. (Unless model number is preceded with \*) The use and layout of these components conform to the requirements of ASTM F1487. To verify product certification, visit [www.ipema.org](http://www.ipema.org)

THIS PLAY AREA & PLAY EQUIPMENT IS DESIGNED FOR AGES 5-12 YEARS UNLESS OTHERWISE NOTED ON PLAN.

IT IS THE MANUFACTURERS OPINION THAT THIS PLAY AREA DOES CONFORM TO THE A.D.A. ACCESSIBILITY STANDARDS, ASSUMING AN ACCESSIBLE PROTECTIVE SURFACING IS PROVIDED, AS INDICATED, OR WITHIN THE ENTIRE USE ZONE.

THIS CONCEPTUAL PLAN WAS BASED ON INFORMATION AVAILABLE TO US. PRIOR TO CONSTRUCTION, DETAILED SITE INFORMATION INCLUDING SITE DIMENSIONS, TOPOGRAPHY EXISTING UTILITIES, SOIL CONDITIONS, AND DRAINAGE SOLUTIONS SHOULD BE OBTAINED, EVALUATED, & UTILIZED IN THE FINAL DESIGN. PLEASE VERIFY ALL DIMENSIONS OF PLAY AREA, SIZE, ORIENTATION, AND LOCATION OF ALL EXISTING UTILITIES, EQUIPMENT, AND SITE FURNISHINGS PRIOR TO ORDERING. SLIDES SHOULD NOT FACE THE HOT AFTERNOON SUN.

CHOOSE A PROTECTIVE SURFACING MATERIAL THAT HAS A CRITICAL HEIGHT VALUE TO MEET THE MAXIMUM FALL HEIGHT FOR THE EQUIPMENT (REF. ASTM F1487 STANDARD CONSUMER SAFETY PERFORMANCE SPECIFICATION FOR PLAYGROUND EQUIPMENT FOR PUBLIC USE, SECTION 8 CURRENT REVISION). THE SUBSURFACE MUST BE WELL DRAINED. IF THE SOIL DOES NOT DRAIN NATURALLY IT MUST BE TILED OR SLOPED 1/8" TO 1/4" PER FOOT TO A STORM SEWER OR A "TRENCH DRAIN".

AREA OF ACCESSIBLE/PROTECTIVE SURFACING (POURED-IN-PLACE SUGGESTED)  
9,471 SF

DESIGNED BY:  
AH

COPYRIGHT: 1/18/2026  
LANDSCAPE STRUCTURES, INC.  
601 7th STREET SOUTH - P.O. BOX 198  
DELANO, MINNESOTA 55328  
PH: 1-800-328-0035 FAX: 1-763-972-6091

Date	Previous Drawing #	Initials





Novi Woods Elementary

PEN1204083-01 • 1.18.2026



© 2026 Landscape Structures. All Rights Reserved



Novi Woods Elementary

PEN1204083-01 • 1.18.2026





*LS* landscape  
structures



Novi Woods Elementary

PEN1204083-01 • 1.18.2026



© 2026 Landscape Structures. All Rights Reserved

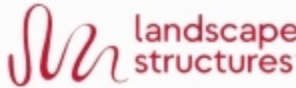

 **Novi Woods Elementary**  **Penchura**  
PEN1204083-01 • 1.18.2026