

RSB Regular Meeting

Tuesday, March 12, 2024 6:00 PM

Administration Building, 500 Big Dog Salmon Way, Angoon, AK 99820

1. Call to Order	Speaker (s) : Board Chair or Vice Chair
1.1. Reading of the Mission Statement	Speaker (s) : Board Chair or Vice Chair
2. Flag Salute	Speaker (s) : Board Chair or Vice Chair
3. Roll Call	Speaker (s) : Board Chair or Vice Chair
4. Recognition	Speaker (s) : Board Chair or Vice Chair
5. Approval of the Agenda	Speaker (s) : Board Chair or Vice Chair
6. Opportunity For Public Comment On Non-Agenda Items	Speaker (s) : Board Chair or Vice Chair
7. Consent Agenda	Speaker (s) : Board Chair or Vice Chair
7.1. Approve RSB Minutes from February 13th 2024	
7.2. Approve the hire of Jessie Morgan as Tlingit Language Aide in Klukwan fro the remainder of this school year.	
7.3. Approve resignation from Mary Long at the end of the current school year.	
7.4. Approve Extra Duty contract as Lead Teacher for Justina Starynski for \$7,250	
7.5. Approve hire of David Lueck as math teacher in Angoon for FY2024-2025	
7.6. Approve Extra Duty contract for Megan Bishop as Track and Field Coach in Gustavus	
7.7. Approve the hire of Alaina Birkel as Paraprofessional at the Klukwan school for the remainder of FY24	
7.8. Approve Classified Staff hire for FY 2024-2025: Danielle Patrick, Tracy Lowell, Paul Dzubay, Morgan Peterson Park, Jeff Irwin, Teresa Terkelson, Deja Jarvis, Duncan Obrien, Rita Brouillette, Joleen Hotch, Christopher Peterson, Darrel Jerue, Karlie Spud, Casey Rard, Rick Peterson, Linnea Lospenosochatel, Megan Moody, JT Collins, Natasha Bennum, Alvin Johnson, Paul James, Peter Duncan, Noelle Willis-Jackson, Frank Joseph, Gina Jim, Stella Estrada, Tali James, Ivanette Johnson, Sheri Singson, Raynelle Jack, Michelle Shatswell	
8. Opportunity for Public Comment on Agenda Items	
9. Financial Report	Speaker (s) : Teri Hoover
10. Action Items	
10.1. Approve Service Agreements between CSD and Kootznawoo for \$46,000	

10.2. Approve Agreement between CSD and Harmony Education

10.3. Approve the sale of Foxes Den Restaurant equipment, supplies, and inventory to Mama Bears Kitchen LLC for \$25,000.

10.4. Approve FY 2024-2025 District Calendar

10.5. Approve Service Agreement between CSD and Kootznawoo for \$55,886.00

11. Special Reports

11.1. Superintendent Report

11.2. ASB Minutes

12. Information/Discussion Items

12.1. Septic Issues at the Gustavus School

12.2. An additional Elementary Teacher in Klukwan for FY25

12.3. Johnson Controls

12.4. Head Lice AR

12.5. Budget Committee

12.6. GEPA Policy

13. Board Member Comments

14. Meetings/Work Sessions/and Other Announcements

14.1. RSB Work Session will be on March 26th

14.2. The next RSB Regular Meeting will be on April 8th

15. Adjournment

Chatham School District Mission Statement

We support students to become independent adults by promoting exceptional educational and cultural experiences.

RSB Regular Meeting
Tuesday, February 13, 2024 6:00 PM Alaskan

ZOOM
500 Big Dog Salmon Way
Angoon, AK 99820

Elizabeth Hooge: Present
III Albert Kookesh: Present
Jack Strong: Present
Jen Todd: Present
Jim Wagner: Present

Present: 5.
All members present

1. Call to Order

Called to order at 6:06 pm

1.1. Reading of the Mission Statement

Elizabeth read the mission statement

2. Flag Salute

Flag Salute conducted

3. Roll Call

Roll call to determine quorum

4. Recognition

Guests,
Clara Natonabah in Klukwan,
Justina Hotch in Klukwan
Emma Demmert Principal in Angoon
Rick Peterson in Tenakee Springs
Richard Hazen student in Gustavus
Rebecca Swanson from Foxes Den
Leann Mattson from Foxes Den
Steve Ilg teacher in Gustavus
Deb Woodruff from Gustavus
Megan Bishop from Gustavus
Stacy Proctor from Gustavus
Janice Btyerlee from Gustavus
Morgan in Gustav in Gustavus
Martin Hutten in Gustavus
Haley in Gustavus

5. Approval of the Agenda

I make a motion to approve the agenda as presented. This motion, made by Jen Todd and seconded by Jim Wagner, Carried.

Elizabeth Hooge: Yea, III Albert Kookesh: Yea, Jack Strong: Yea, Jen Todd: Yea, Jim Wagner: Yea

Yea: 5, Nay: 0

Jen makes a motion to amend the approval of the agenda to add approved travel to Hawaii for Ivan Ramey to the Collaborative Cultural CTE workshop in March. Changed to 10.4 Seconded by Jim

Roll call vote passed unanimously.

Roll call vote approved amended agenda passed unanimously. Motion carries.

6. Opportunity For Public Comment On Non-Agenda Items

Justina comments on her appreciation to Mrs. Shatswell's help and support to get things ready and done.

7. Consent Agenda

I make a motion to approve the consent agenda as presented with the addition of 10.4 Ivan Ramey travel to Hawaii. This motion, made by Jim Wagner and seconded by III Albert Kookesh, Carried.

Elizabeth Hooge: Yea, III Albert Kookesh: Yea, Jack Strong: Yea, Jen Todd: Yea, Jim Wagner: Yea

Yea: 5, Nay: 0

Does anything need to be pulled from the consent agenda?

7.1. Approve RSB Meeting Minutes from 1/9/24, and 1/29/24

7.2. Approve hire of Casey Rard as Student Transportation Driver in Klukwan.

7.3. Approve hire of Karlie Spud as Tlingit Language Aide in Klukwan.

7.4. Approve hire of Noelle Willis-Jackson as Sped Para in Angoon.

8. Opportunity for Public Comment on Agenda Items

Public comment on agenda items:

Karen McSpadden expresses her compassion for the student-run restaurant, her meeting with a restaurant consultant, and the information he shared with her. There are other programs that may be able to assist with some funding, is there a way to pay off the debt over time with the development of a repayment plan. The cost for a 3 day consultation not including travel or lodging is \$6900.00

Jim Kearns lives in Gustavus. He states that his customers have come to rely on the foxes den for their dinners. They have all expressed their support for such a program. He has been impressed with the instructors and the students. He has been very involved in athletics over the years and he states that those activities are often funded by the district, and should be for the students.

Karen and Martin Hutten from Gustavus voiced support of the foxes den restaurant. They go there regularly. They have enjoyed watching the students there. It should be open for the students. It is running well as far as they can see as restaurant goes.

Paul James comments that the meeting does not get properly posted in Angoon, so it's been hard to join meetings. His issue is with Frontline. He thought that we were going to switch to getting paid every two weeks. He got back from a trip, and asked for an advance and they told him that he could not because it was too close to payday.

Janice Byerlee comments how she supports the foxes den. There are very few amenities here in

Gustavus, she has really enjoyed it. It has been the only place open in the wintertime, so very important for the community. They go there every Friday night. She brought her class there last year and they really enjoyed it. She wants to second everything that Jim Kearns said as well. Jack Strong comments that we are supporting students to become independent adults by providing exceptional education, and one of those pieces is that the money coming in has to cover the money going out.

Deb Woodruff comments that she has become more aware about the problems going on with the entire state for school funding. She feels like just learning about the problems here that fund raising and other things may be able to be explored. She cares about the students and has been impressed with the work they have done. Feels like there are other opportunities for grants or other things. Her guests count on the foxes den for two meals a day. The eateries are always a high point for our community.

Stacy Proctor comments that she is lifetime resident of Gustavus, she realizes as board members you have difficult decisions to make. She knows that they have a fiduciary responsibility to all the students in the district. If it does move forward it would definitely need more oversight and needs to run differently from how it has been.

Richard Hazen comments as a student who works at the restaurant. It has taught him a lot they have been really good about it. There is still more he could learn there and it would be good to keep it open to teach other students too, how to cook things in different ways, and temperatures, for safety. It's a good place to start out, he has never had a job, and it has taught me well.

Rebecca Swanson speaks as the manager at the foxes den. She thinks it has been a great program, she thinks some things have slipped through the cracks. The kids working now would not have an opportunity to get a job in other communities without a stepping stone. They get job reference calls for students who have been able to move on to better jobs, and it has been great. She would like to see some improvements and come up with a way that this can be continued.

Leann Mattson comments on how students working there have been learning a lot and growing. She comments about her and the other managers pay not being budgeted correctly.

Morgan Park in Gustavus comments as a Gustavus resident that if the restaurant does stay open it should be managed differently. She also comments how the school district is under no obligation to run a restaurant.

Steve Ilg comments as a new teacher to Gustavus that he thinks there needs to be a little more time and communication between the community and the school board. He comments that it would only be fair to give an opportunity for some open communication and for the community to assist in what ways that they can. He just started helping at the restaurant, as well as teaching other CTE classes at the school. Asks that they just give it a little time.

9. Financial Report

Teri Hoover comments about the foxes den that this is not something that just all of a sudden happened. It has been talked about with the auditors and the board for some time.

The financial report is based around the general fund. She gives a verbal summary. She is working on an FY 24 budget revision, she is planning to have that ready by the March board meeting.

Jen board member asks about the salary for the foxes den managers and how their salary is budgeted.

10. Action Items

10.1. Foxes Den Student-Run Restaurant in Gustavus Closure or Plan for Moving Forward

I make a motion to close the foxes den item 10.1 Roll call vote passed unanimously. Motion carries. This motion, made by III Albert Kookesh and seconded by Jim Wagner, Carried.

Elizabeth Hooge: Yea, III Albert Kookesh: Yea, Jack Strong: Yea, Jen Todd: Yea, Jim Wagner: Yea

Yea: 5, Nay: 0

Ralph gave a verbal summary

The current deficit is about \$220,000 His recommendation to the board is to divest from the venture at this time because we can not continue to lose money like that.

Board Member comment

Albert comments that it was really sad for him to make that motion. He does not see this working out financially for the district. He does apologize to all the students the staff and the community.

Jack comments on how restaurants have a 60% fail rate. Only 20% will actually find success. He hopes the students do not feel bad about the decision. There shouldn't be any ill feelings about doing what we have to do.

Jen comments on how she appreciates everyone's comments tonight and the ingenuity and support of the community. It is purely a financial decision, that she supports the motion of closing it.

Jim comments that education is a good teacher, and if there was a restaurateur in the group who could give insight it would be helpful. There was supposed to be a business plan and curriculum set up and someone to oversee and document. There was never any budget set up for this. It is not to fault anyone, it is just the fault of the board. The population base in Gustavus is marginal to support a restaurant in the southeast. He believes we could use those funds to better support the district as a whole.

Ralph adds how much he appreciates the board in being brave in making the decisions that they have to make for the people who have entrusted them to make those decisions.

Elizabeth comments that the restaurant was never viewed that the restaurant would ever be completely self-sustaining. But she never thought the district would have to put so much money into it. It is very unfortunate that we are at this junction. She feels the board bears the responsibility. She also feels that the flow of money does need to stop at this time.

Ralph states that the deficit is a deficit to the general fund and the district will continue to have to pay this back over the next several years. Teri comments that the foxes den has their own fund, but every year it has lost money, so now every year the district will have to more money from the general fund to the foxes den enterprise fund to pay it back. Jim asks if it can be strung out for 5 years. She comments that if the district is showing good faith that they are trying to reduce the deficit, then it should be fine to do it over five years.

A comment from Sean Mattson asks why nobody in the district caught that Leann and Rebecca's salary was being paid out of another fund. There seems to be accounting errors. Elizabeth comments that the accountants did highlight this at both last years and this years audits.

Roll call vote passed unanimously. Motion carries.

10.2. Approve travel to Vancouver British Columbia for the AISES Conference.

I make a motion to approve travel to Vancouver British Columbia for the AISES conference. Roll call vote passed unanimously. Motion carries. This motion, made by Jim Wagner and seconded by III Albert Kookesh, Carried.

Elizabeth Hooge: Yea, III Albert Kookesh: Yea, Jack Strong: Yea, Jen Todd: Yea, Jim Wagner: Yea

Yea: 5, Nay: 0

Ralph gave a verbal summary

This is part of the Full Service Community Schools Grant

No board member comment

10.3. Approve new position of Angoon Alaskan Youth Steward Crew Leader to be paid for by pass-through funding from AYS.

I make a motion to approve a new position for AYS crew leader to be paid for by pass-through funding paid for by AYS. Roll call vote passed unanimously. Motion carries. This motion, made by Jim Wagner and seconded by Jen Todd, Carried.

Elizabeth Hooge: Yea, III Albert Kookesh: Yea, Jack Strong: Yea, Jen Todd: Yea, Jim Wagner: Yea

Yea: 5, Nay: 0

Ralph gave a verbal summary

No board member comment

10.4. Approve travel to Hawaii for Ivan Ramey to attend the Collaboration Cultural Cte workshop in March.

I make a motion to approve travel to Hawaii for Ivan Ramey to attend the Collaboration Cultural CTE workshop in March. Roll call vote passed unanimously. Motion carries. This motion, made by Jim Wagner and seconded by Jack Strong, Carried.

Elizabeth Hooge: Yea, III Albert Kookesh: Yea, Jack Strong: Yea, Jen Todd: Yea, Jim Wagner: Yea

Yea: 5, Nay: 0

Ralph gave a verbal summary

No board member comments

11. Special Reports

No additions, changes on the reports

11.1. Superintendent Report

Ralph gave a verbal summary and highlighted some of the items in his report.

11.2. ASB Minutes

No questions on the minutes

12. Information/Discussion Items

12.1. Admin Retreat in Juneau

Ralph gave a verbal summary

Jim comments that he believes, even with the benefits of meeting in person he would prefer to see the admin meet via Zoom to save on funds.

We will plan to do the retreat virtually so that we do not have to spend any funds on that.

12.2. School Board Appreciation Month

Ralph comments about how we appreciate them very much. You are appreciated.

12.3. Studded tires for the Klukwan van

The tires will be purchased. The purchase should be able to come out of transportation funds.

12.4. Head Lice AR

We will look at what had been in the minutes years ago and compare the two.

12.5. Approve FY 2024-2025 District Calendar

Ralph gave a verbal summary

Would like to push the survey out again and see if we can get some more input, and get some more information from the admin team.

13. Board Member Comments

Jim thanks Ralph for his information.

14. Meetings/Work Sessions/and Other Announcements

14.1. The RSB Work Session will be on February 27th 2024.

14.2. The next RSB Regular Meeting is on March 12th 2024

15. Adjournment

Jim makes a motion to adjourn.

No objections to adjournment

Adjourned at 8:37 PM

Chatham School District
Revenue & Expense Accounts
 Budget vs Actual - Actual, Encumbrance
 For the Period from February 1, 2024 to February 29, 2024

Fund: 100-General Fund (100), Fund Class: Unrestricted (UNRESTRICT)

	Annual Budget	Period To Date - Actual	Year To Date - Actual	Year To Date - Encumbrance	Budget Remaining
031-Earnings on Investments	-3,000.00	-1,624.03	-6,154.25		3,154.25
040-Other Local Revenues	-20,000.00	-24,184.38	-74,163.98		54,163.98
046-Rental Income	-4,000.00	-9,488.00	-21,883.95		17,883.95
047-E-Rate	-252,000.00	-9,500.40	-142,419.20		-109,580.80
051-Foundation Program Revenue	-3,371,239.00	-268,616.00	-2,148,928.00		-1,222,311.00
056-TRS On-Behalf Revenue	-149,391.00				-149,391.00
057-PERS On-Behalf Revenue	-23,945.00				-23,945.00
090-Other State Revenues	-900.00				-900.00
110-Impact Aid	-182,343.00		-78,868.00		-103,475.00
181-Oth Rev from Fed State of AK	-243,101.00				-243,101.00
Total Revenue	-4,249,919.00	-313,412.81	-2,472,417.38		-1,777,501.62
311-Certified Superintendent	86,520.00	7,336.00	58,016.00		28,504.00
313-Certified Principal	170,000.00	15,502.00	93,180.66		76,819.34
315-Certified Teacher	807,932.00	88,574.19	509,668.48		298,263.52
316-Certified Extra Duty Pay	88,275.00	1,870.00	32,346.83		55,928.17
321-Director/Coordinator/Mgr	62,000.00	5,270.00	26,350.00		35,650.00
323-Non-Certified Aide	189,769.00	18,274.53	113,073.71		76,695.29
324-Non-Certified Support Staff	276,220.00	23,155.37	169,479.60		106,740.40
325-Non Cert Maintenance Custodial	165,133.00	15,335.91	110,231.18		54,901.82
329-Non-Certified Substitute/Temp	79,050.00	11,049.24	54,877.87		24,172.13
361-Life/Health Insurance	379,140.00	30,553.70	187,642.31		191,497.69
362-Unemployment Insurance	8,161.00	1,860.25	8,461.36		-300.36
363-Workers' Compensation	27,270.00	2,790.31	17,788.43		9,481.57
364-FICA Contribution	75,368.00	7,079.96	46,315.74		29,052.26
365-TRS	294,171.00	14,196.83	86,417.28		207,753.72
366-PERS	176,104.00	12,828.17	88,266.99		87,837.01
369-Other Employee Benefits	5,500.00		5,385.91		114.09
410-Professional Technical Service	267,038.00	10,673.88	65,828.87		201,209.13
412-Auditing Accounting Service	88,000.00		45,282.75		42,717.25
414-Legal Services	10,000.00	2,144.00	7,059.50		2,940.50
420-Staff Travel & Per Diem	61,600.00	8,233.54	47,984.24		13,615.76
425-Student Travel	120,000.00	20,849.25	65,319.05		54,680.95
430-Utility Services	500.00				500.00
431-Water & Sewer	39,375.00	1,932.47	8,232.47		31,142.53

Chatham School District
Revenue & Expense Accounts
 Budget vs Actual - Actual, Encumbrance
 For the Period from February 1, 2024 to February 29, 2024

Fund: 100-General Fund (100), Fund Class: Unrestricted (UNRESTRICT)

	Annual Budget	Period To Date - Actual	Year To Date - Actual	Year To Date - Encumbrance	Budget Remaining
432-Garbage	5,725.00	1,260.00	3,643.44		2,081.56
433-Communications	319,500.00	31,988.35	204,463.10		115,036.90
435-Energy	35,000.00	5,358.20	17,552.69		17,447.31
436-Electricity	234,000.00	22,735.95	95,017.53		138,982.47
438-Heating Fuel	144,000.00	26,615.91	67,293.84		76,706.16
440-Other Purchased Services	29,500.00	8,741.26	39,905.39		-10,405.39
441-Rentals/Leases	30,000.00	554.37	1,310.19		28,689.81
442-Building Repair & Maintenance	19,500.00	7,252.35	16,206.70		3,293.30
443-Equipment Repair & Maintenance	19,100.00	8,577.14	13,664.16		5,435.84
446-Property Insurance	115,556.00		105,002.70		10,553.30
447-Liability Insurance	42,080.00		44,417.46		-2,337.46
450-Supplies	30,350.00	904.57	102,559.31		-72,209.31
452-Maintenance Supplies	15,600.00	1,521.33	13,140.99		2,459.01
453-Janitorial Supplies	9,500.00	7,598.71	11,772.84		-2,272.84
454-Office Supplies	7,600.00	2,104.17	10,033.53		-2,433.53
458-Vehicle Gasoline, Diesel, Oil	4,050.00	647.60	4,076.80		-26.80
459-Food		613.48	864.08		-864.08
471-Textbooks	2,000.00	680.00	37,309.71		-35,309.71
472-Library Books	1,250.00				1,250.00
479-Other Supplies Materials Media	2,200.00		703.73		1,496.27
490-Other Expenses	10,050.00	175.73	7,635.13		2,414.87
491-Dues and Fees	26,125.00	19,678.40	36,548.97		-10,423.97
495-Indirect Cost Recovery	-60,000.00		-56,172.15		-3,827.85
Total Expenditures	4,519,812.00	446,517.12	2,624,159.37		1,895,652.63

Bank Account - Check Details

Monday, March 4, 2024

Period: 02/01/24..02/29/24

Page 1

Chatham School District

JNUSERRC\terih

This report also includes bank accounts that only have balances.

Bank Account: No.: B001, Date Filter: 02/01/24..02/29/24

Check Date	Check No.	Description	Amount	Printed Amount	Voided Amount	Entry Status	Original Entry S	Bal. Accou	Bal. Account No.	Entry No.
B001 General Fund Checking										
Phone No.										
02/06/24	To 29745	US Foods, Inc.	5,446.34	5,446.34	0.00	Posted	Vendo	US FOODS		50412
02/09/24	To 33186	Assoc of Alaska School Boards	12,466.07	12,466.07	0.00	Posted	Vendo	AASB		50413
02/09/24	To 33187	AK Communications Systems	2,161.17	2,161.17	0.00	Posted	Vendo	ACS		50414
02/09/24	To 33188	AK Hydroponic Gardens	1,176.11	1,176.11	0.00	Posted	Vendo	AK		50415
02/09/24	To 33189	Ak Industrial Hardware	17.60	17.60	0.00	Posted	Vendo	AK		50416
02/09/24	To 33190	Alaska Power Company	3,512.63	3,512.63	0.00	Posted	Vendo	AK POWER		50417
02/09/24	To 33191	Alaska Seaplanes Service,	2,811.00	2,811.00	0.00	Posted	Vendo	AK		50418
02/09/24	To 33192	AK Staff Development Network	500.00	500.00	0.00	Posted	Vendo	AK STAFF		50419
02/09/24	To 33193	Amanda Mayton	818.00	818.00	0.00	Posted	Vendo	AMANDA		50420
02/09/24	To 33194	American Fast Freight	51.84	51.84	0.00	Posted	Vendo	AMERICAN		50421
02/09/24	To 33195	Angoon Trading	400.06	400.06	0.00	Posted	Vendo	ANGOON		50422
02/09/24	To 33196	AT&T	69.93	69.93	0.00	Posted	Vendo	AT&T/CARO		50423
02/09/24	To 33197	Blue Ribbon Distributing	553.18	553.18	0.00	Posted	Vendo	BLUE		50424
02/09/24	To 33198	Captain's Choice Motel	547.20	547.20	0.00	Posted	Vendo	CAPTAINS		50425
02/09/24	To 33199	Christopher Peterson	228.46	228.46	0.00	Posted	Vendo	CHRISTOPH		50426
02/09/24	To 33200	City of Angoon	1,160.00	1,160.00	0.00	Posted	Vendo	CITY OF		50427
02/09/24	To 33201	CropKing, Inc.	3,000.00	3,000.00	0.00	Posted	Vendo	CROPKING,		50428
02/09/24	To 33202	Daniel Fredrickson, Jr.	885.00	885.00	0.00	Posted	Vendo	DANIEL		50429
02/09/24	To 33203	Darcie Ziel	249.71	249.71	0.00	Posted	Vendo	DARCIE		50430
02/09/24	To 33204	David Lueck	150.00	150.00	0.00	Posted	Vendo	DAVID		50431
02/09/24	To 33205	Delta Western	10,954.78	10,954.78	0.00	Posted	Vendo	DELTA		50432
02/09/24	To 33206	Duane J. Samato	585.00	585.00	0.00	Posted	Vendo	DUANE J.		50433
02/09/24	To 33207	Duncan O'Brien	1,230.00	1,230.00	0.00	Posted	Vendo	DUNCAN		50434
02/09/24	To 33208	Elaine Kookesh-Jack	885.00	885.00	0.00	Posted	Vendo	ELAINE		50435
02/09/24	To 33209	Emma Demmert	435.00	435.00	0.00	Posted	Vendo	EMMA		50436
02/09/24	To 33210	Equitable Equi-Vest Unit	1,350.00	1,350.00	0.00	Posted	Vendo	EQUITABLE		50437
02/09/24	To 33211	Frontline Technologies Group	525.00	525.00	0.00	Posted	Vendo	FRONTLINE		50438
02/09/24	To 33212	GCI	2,467.58	2,467.58	0.00	Posted	Vendo	GCI/ANCH		50439
02/09/24	To 33213	Ginette St. Clair	775.78	775.78	0.00	Posted	Vendo	GINETTE		50440
02/09/24	To 33214	Grainger	7,803.54	7,803.54	0.00	Posted	Vendo	GRAINGER		50441
02/09/24	To 33215	Gretchen Randolph	144.10	144.10	0.00	Posted	Vendo	GRETCHEN		50442
02/09/24	To 33216	Grizzly Industrial, Inc.	1,907.08	1,907.08	0.00	Posted	Vendo	GRIZZLY		50443
02/09/24	To 33217	Gustavus Dray, Inc.	4,952.87	4,952.87	0.00	Posted	Vendo	GUSTAVUS		50444
02/09/24	To 33218	Haines Home Building	254.98	254.98	0.00	Posted	Vendo	HAINES		50445
02/09/24	To 33219	Heidi Davis	1,256.29	1,256.29	0.00	Posted	Vendo	HEIDI DAVIS		50446
02/09/24	To 33220	Horace Mann Life Insurance	27.37	27.37	0.00	Posted	Vendo	HORACE		50447
02/09/24	To 33221	Houghton Mifflin Harcourt	680.00	680.00	0.00	Posted	Vendo	HOUGHTON		50448
02/09/24	To 33222	Inside Passage Electric Coop	27,682.85	27,682.85	0.00	Posted	Vendo	INSIDE		50449
02/09/24	To 33223	Jessica Shanahan	599.17	599.17	0.00	Posted	Vendo	JESSICA		50450
02/09/24	To 33224	Johnson Controls Fire	5,957.00	5,957.00	0.00	Posted	Vendo	JOHNSON		50451
02/09/24	To 33225	Jonathan Wunrow	5,500.00	5,500.00	0.00	Posted	Vendo	JONATHAN		50452
02/09/24	To 33226	Karen McSpadden	360.00	360.00	0.00	Posted	Vendo	KAREN		50453
02/09/24	To 33227	Kelley Connect	1,194.44	1,194.44	0.00	Posted	Vendo	KELLEY		50454
02/09/24	To 33228	Kelly McLaughlin	2,004.82	2,004.82	0.00	Posted	Vendo	KELLY		50455
02/09/24	To 33229	Kyle Johnson, Sr.	885.00	885.00	0.00	Posted	Vendo	KYLE		50456
02/09/24	To 33230	Learning A-Z	1,228.50	1,228.50	0.00	Posted	Vendo	LEARNING		50457
02/09/24	To 33231	Lutak Lumber	261.96	261.96	0.00	Posted	Vendo	LUTAK		50458

Bank Account - Check Details

Monday, March 4, 2024

Period: 02/01/24..02/29/24

Page 2

Chatham School District

JNUSERRC\terih

Check Date	Check No.	Description	Amount	Printed Amount	Voided Amount	Entry Status	Original Entry S	Bal. Accou	Bal. Account No.	Entry No.
02/09/24	To 33232	NEA - Alaska	1,096.06	1,096.06	0.00	Posted	Vendo	NEA - AK	50459	
02/09/24	To 33233	Purchase Power	593.90	593.90	0.00	Posted	Vendo	PURCHASE	50460	
02/09/24	To 33234	Ralph Watkins	1,350.00	1,350.00	0.00	Posted	Vendo	RALPH	50461	
02/09/24	To 33235	Rita Brouillette	1,120.05	1,120.05	0.00	Posted	Vendo	RITA	50462	
02/09/24	To 33236	Scott Burton Productions	7,760.00	7,760.00	0.00	Posted	Vendo	SCOTT	50463	
02/09/24	To 33237	Tenakee Fuel Service	50.34	50.34	0.00	Posted	Vendo	TENAKEE	50464	
02/09/24	To 33238	TIDES Education Associates	12,500.00	12,500.00	0.00	Posted	Vendo	TIDES	50465	
02/09/24	To 33239	Timberdoodle	109.35	109.35	0.00	Posted	Vendo	TIMBERDOO	50466	
02/09/24	To 33240	Vija Pelekis	180.45	180.45	0.00	Posted	Vendo	VIJA	50467	
02/09/24	To 33241	Ward Air, Inc.	4,779.50	4,779.50	0.00	Posted	Vendo	WARD AIR	50468	
02/14/24	To 33242	Killisnoo Harbor, LLC	1,500.00	1,500.00	0.00	Posted	Vendo	KILLISNOO	50473	
02/15/24	To 29746	US Foods, Inc.	1,692.20	1,692.20	0.00	Posted	Vendo	US FOODS	50474	
02/23/24	To 33243	Assoc of Alaska School Boards	6,248.00	6,248.00	0.00	Posted	Vendo	AASB	50635	
02/23/24	To 33244	AK Communications Systems	2,092.62	2,092.62	0.00	Posted	Vendo	ACS	50636	
02/23/24	To 33245	AK Hydroponic Gardens	8,712.00	8,712.00	0.00	Posted	Vendo	AK	50637	
02/23/24	To 33246	Alaska Seaplanes Service,	11,191.49	11,191.49	0.00	Posted	Vendo	AK	50638	
02/23/24	To 33247	Alaska Telephone Company	290.73	290.73	0.00	Posted	Vendo	ALASKA	50639	
02/23/24	To 33248	Amber Taylor	73.50	73.50	0.00	Posted	Vendo	AMBER	50640	
02/23/24	To 33249	Angela Wheaton	252.00	252.00	0.00	Posted	Vendo	ANGELA	50641	
02/23/24	To 33250	Angoon Oil	2,480.00	2,480.00	0.00	Posted	Vendo	ANGOON	50642	
02/23/24	To 33251	Angoon Trading	749.31	749.31	0.00	Posted	Vendo	ANGOON	50643	
02/23/24	To 33252	AT&T	23.60	23.60	0.00	Posted	Vendo	AT&T/CARO	50644	
02/23/24	To 33253	Best Western Country Lane	3,529.56	3,529.56	0.00	Posted	Vendo	BEST	50645	
02/23/24	To 33254	Beverly McGee	128.00	128.00	0.00	Posted	Vendo	BEVERLY	50646	
02/23/24	To 33255	Blue Ribbon Distributing	630.00	630.00	0.00	Posted	Vendo	BLUE	50647	
02/23/24	To 33256	Byte Networking, LLC	2,916.00	2,916.00	0.00	Posted	Vendo	BYTE	50648	
02/23/24	To 33257	Camille Bacon-Schulte	136.50	136.50	0.00	Posted	Vendo	CAMILLE	50649	
02/23/24	To 33258	CareerSafe	320.00	320.00	0.00	Posted	Vendo	CAREERSA	50650	
02/23/24	To 33259	Caroline Casipit	90.00	90.00	0.00	Posted	Vendo	CAROLINE	50651	
02/23/24	To 33260	Chantel Mulligan-Rear	154.10	154.10	0.00	Posted	Vendo	CHANTEL	50652	
02/23/24	To 33261	City of Angoon	1,160.00	1,160.00	0.00	Posted	Vendo	CITY OF	50653	
02/23/24	To 33262	City of Gustavus	860.00	860.00	0.00	Posted	Vendo	CITY OF	50654	
02/23/24	To 33263	Clear Water Plumbing &	3,864.43	3,864.43	0.00	Posted	Vendo	CLEAR	50655	
02/23/24	To 33264	CropKing, Inc.	4,354.95	4,354.95	0.00	Posted	Vendo	CROPKING,	50656	
02/23/24	To 33265	Danielle Patrick	151.80	151.80	0.00	Posted	Vendo	DANIELLE	50657	
02/23/24	To 33266	Darcie Ziel	367.40	367.40	0.00	Posted	Vendo	DARCIE	50658	
02/23/24	To 33267	Deja Jarvis	126.00	126.00	0.00	Posted	Vendo	DEJA	50659	
02/23/24	To 33268	Delta Western	4,290.32	4,290.32	0.00	Posted	Vendo	DELTA	50660	
02/23/24	To 33269	Duane J. Samato	300.00	300.00	0.00	Posted	Vendo	DUANE J.	50661	
02/23/24	To 33270	Duncan O'Brien	1,003.00	1,003.00	0.00	Posted	Vendo	DUNCAN	50662	
02/23/24	To 33271	Elm Robichaud	228.75	228.75	0.00	Posted	Vendo	ELM	50663	
02/23/24	To 33272	Eric Benedict	5,000.00	5,000.00	0.00	Posted	Vendo	ERIC	50664	
02/23/24	To 33273	Byte Networking, LLC	1,828.00	1,828.00	0.00	Posted	Vendo	FIBRE	50665	
02/23/24	To 33274	Fork Farms LLC	664.95	664.95	0.00	Posted	Vendo	FORK	50666	
02/23/24	To 33275	Four Ravens	1,500.00	1,500.00	0.00	Posted	Vendo	FOUR	50667	
02/23/24	To 33276	Frank Coenraad	613.48	613.48	0.00	Posted	Vendo	FRANK	50668	
02/23/24	To 33277	GCI	2,462.16	2,462.16	0.00	Posted	Vendo	GCI/ANCH	50669	
02/23/24	To 33278	Geoffrey Fosse	396.00	396.00	0.00	Posted	Vendo	GEOFFREY	50670	
02/23/24	To 33279	Gustavus Dray, Inc.	3,505.03	3,505.03	0.00	Posted	Vendo	GUSTAVUS	50671	
02/23/24	To 33280	Gustavus Holdings	1,236.00	1,236.00	0.00	Posted	Vendo	GUSTAVUS	50672	
02/23/24	To 33281	Gustavus Landscaping	1,383.75	1,383.75	0.00	Posted	Vendo	GUSTAVUS	50673	
02/23/24	To 33282	Haines Home Building	49.95	49.95	0.00	Posted	Vendo	HAINES	50674	
02/23/24	To 33283	Hannah McComish	112.00	112.00	0.00	Posted	Vendo	HANNAH	50675	

Bank Account - Check Details

Monday, March 4, 2024

Period: 02/01/24..02/29/24

Page 3

Chatham School District

JNUSERRC\terih

Check Date	Check No.	Description	Amount	Printed Amount	Voided Amount	Entry Status	Original Entry S	Bal. Accou	Bal. Account No.	Entry No.
02/23/24	To 33284	Hayley Zink	228.00	228.00	0.00	Posted	Vendo	HAYLEY	50676	
02/23/24	To 33285	Heidi Davis	117.00	117.00	0.00	Posted	Vendo	HEIDI DAVIS	50677	
02/23/24	To 33286	Ivan Ramey	735.00	735.00	0.00	Posted	Vendo	IVAN	50678	
02/23/24	To 33287	James Wagner	105.80	105.80	0.00	Posted	Vendo	JAMES	50679	
02/23/24	To 33288	Janice Byerlee	25.30	25.30	0.00	Posted	Vendo	JANICE	50680	
02/23/24	To 33289	Jennifer Todd	95.00	95.00	0.00	Posted	Vendo	JENNIFER	50681	
02/23/24	To 33290	Jessica Mulligan	166.40	166.40	0.00	Posted	Vendo	JESSICA	50682	
02/23/24	To 33291	Jessie Soder	170.80	170.80	0.00	Posted	Vendo	JESSIE	50683	
02/23/24	To 33292	Johnson Controls Fire	4,268.13	4,268.13	0.00	Posted	Vendo	JOHNSON	50684	
02/23/24	To 33293	Jordan Wagner	108.10	108.10	0.00	Posted	Vendo	JORDAN	50685	
02/23/24	To 33294	Karen McSpadden	210.00	210.00	0.00	Posted	Vendo	KAREN	50686	
02/23/24	To 33295	Katelyn Tippery	125.40	125.40	0.00	Posted	Vendo	KATELYN	50687	
02/23/24	To 33296	Kathryn Cruz	5,000.00	5,000.00	0.00	Posted	Vendo	KATHRYN	50688	
02/23/24	To 33297	Kelley Connect	1,318.01	1,318.01	0.00	Posted	Vendo	KELLEY	50689	
02/23/24	To 33298	LeAnn Mattson	122.00	122.00	0.00	Posted	Vendo	LEANN	50690	
02/23/24	To 33299	Leland Barker	653.25	653.25	0.00	Posted	Vendo	LELAND	50691	
02/23/24	To 33300	Lizz Devenny	402.00	402.00	0.00	Posted	Vendo	LIZZ	50692	
02/23/24	To 33301	Lori Moore	375.00	375.00	0.00	Posted	Vendo	LORI	50693	
02/23/24	To 33302	Lutak Lumber	138.90	138.90	0.00	Posted	Vendo	LUTAK	50694	
02/23/24	To 33303	Marlene Beltran	104.90	104.90	0.00	Posted	Vendo	MARLENE	50695	
02/23/24	To 33304	Megan Bishop	228.00	228.00	0.00	Posted	Vendo	MEGAN	50696	
02/23/24	To 33305	Michelle Shatswell	199.50	199.50	0.00	Posted	Vendo	MICHELLE	50697	
02/23/24	To 33306	Molly Kelly	224.00	224.00	0.00	Posted	Vendo	MOLLY	50698	
02/23/24	To 33307	Morgan Linhart	126.00	126.00	0.00	Posted	Vendo	MORGAN	50699	
02/23/24	To 33308	Public Education Health Trust	34,668.60	34,668.60	0.00	Posted	Vendo	PEHT	50700	
02/23/24	To 33309	Pitney Bowes Global Financial	554.37	554.37	0.00	Posted	Vendo	PITNEY	50701	
02/23/24	To 33310	Purchase Power	43.40	43.40	0.00	Posted	Vendo	PURCHASE	50702	
02/23/24	To 33311	Rachel Parks	67.20	67.20	0.00	Posted	Vendo	RACHEL	50703	
02/23/24	To 33312	Renee Patrick	149.50	149.50	0.00	Posted	Vendo	RENEE	50704	
02/23/24	To 33313	Sedor Wedlandt Evans Filippi	2,144.00	2,144.00	0.00	Posted	Vendo	SEDOR	50705	
02/23/24	To 33314	Stacey Proctor	216.00	216.00	0.00	Posted	Vendo	STACEY	50706	
02/23/24	To 33315	State of Alaska	72.11	72.11	0.00	Posted	Vendo	STATE OF	50707	
02/23/24	To 33316	Susan Collins	268.00	268.00	0.00	Posted	Vendo	SUSAN	50708	
02/23/24	To 33317	Susan Schaff	670.00	670.00	0.00	Posted	Vendo	SUSAN	50709	
02/23/24	To 33318	Tanya Salmi	360.00	360.00	0.00	Posted	Vendo	TANYA	50710	
02/23/24	To 33319	Tenakee Fuel Service	3,041.01	3,041.01	0.00	Posted	Vendo	TENAKEE	50711	
02/23/24	To 33320	Timberdoodle	2,614.70	2,614.70	0.00	Posted	Vendo	TIMBERDOO	50712	
02/28/24	To 29747	Assoc of Alaska School Boards	182,599.68	182,599.68	0.00	Posted	Vendo	AASB	50713	
02/29/24	To 29748	US Foods, Inc.	942.53	942.53	0.00	Posted	Vendo	US FOODS	50714	
General Fund Checking			469,977.23	469,977.23	0.00					

Chatham School District
Revenue & Expense Accounts
 Budget vs Actual - Actual, Encumbrance
 For the Period from February 1, 2024 to February 29, 2024

Fund: 100-General Fund (100), Fund Class: Unrestricted (UNRESTRICT)
 School: Angoon (060)

	Annual Budget	Period To Date - Actual	Year To Date - Actual	Year To Date - Encumbrance	Budget Remaining
Total Revenue					
313-Certified Principal	94,000.00	7,835.33	54,847.31		39,152.69
315-Certified Teacher	352,297.00	45,094.73	238,330.39		113,966.61
316-Certified Extra Duty Pay	14,500.00	250.00	7,276.83		7,223.17
323-Non-Certified Aide	79,005.00	8,308.96	53,607.33		25,397.67
324-Non-Certified Support Staff	50,743.00	2,172.05	11,475.41		39,267.59
325-Non Cert Maintenance Custodial	74,458.00	7,157.13	51,764.37		22,693.63
329-Non-Certified Substitute/Temp	27,000.00	2,129.91	28,779.33		-1,779.33
361-Life/Health Insurance	75,600.00	6,549.48	39,028.77		36,571.23
362-Unemployment Insurance	2,874.00	747.47	3,114.75		-240.75
363-Workers' Compensation	9,710.00	1,121.19	6,860.21		2,849.79
364-FICA Contribution	24,293.00	2,107.06	15,242.70		9,050.30
365-TRS	117,593.00	6,648.02	37,087.06		80,505.94
366-PERS	52,513.00	3,566.60	24,110.65		28,402.35
369-Other Employee Benefits	2,000.00		170.17		1,829.83
410-Professional Technical Service	6,000.00	955.56	14,406.20		-8,406.20
420-Staff Travel & Per Diem	6,000.00	1,176.31	8,146.24		-2,146.24
425-Student Travel	60,000.00	18,543.15	44,501.76		15,498.24
430-Utility Services	500.00				500.00
431-Water & Sewer	10,000.00	1,920.00	7,680.00		2,320.00
432-Garbage	2,200.00	400.00	1,600.00		600.00
433-Communications	100,500.00	10,924.92	71,849.61		28,650.39
435-Energy	35,000.00	5,358.20	17,552.69		17,447.31
436-Electricity	152,000.00	15,943.56	61,946.16		90,053.84
438-Heating Fuel	12,000.00	2,480.00	2,480.00		9,520.00
440-Other Purchased Services	1,000.00				1,000.00
441-Rentals/Leases	10,000.00	259.26	259.26		9,740.74
442-Building Repair & Maintenance	10,000.00	2,462.46	8,488.50		1,511.50
443-Equipment Repair & Maintenance	5,500.00		1,516.54		3,983.46
446-Property Insurance	51,683.00		41,634.61		10,048.39
450-Supplies	12,750.00	643.84	39,303.14		-26,553.14
452-Maintenance Supplies	10,000.00	1,521.33	5,159.90		4,840.10
453-Janitorial Supplies	3,000.00	6,874.03	7,779.33		-4,779.33
454-Office Supplies	2,000.00	1,348.62	4,906.99		-2,906.99

Chatham School District
 Revenue & Expense Accounts
 Budget vs Actual - Actual, Encumbrance
 For the Period from February 1, 2024 to February 29, 2024

Fund: 100-General Fund (100), Fund Class: Unrestricted (UNRESTRICT)
 School: Angoon (060)

	Annual Budget	Period To Date - Actual	Year To Date - Actual	Year To Date - Encumbrance	Budget Remaining
458-Vehicle Gasoline, Diesel, Oil	3,500.00		1,768.33		1,731.67
459-Food		613.48	864.08		-864.08
471-Textbooks	500.00	226.67	11,921.19		-11,421.19
472-Library Books	500.00				500.00
479-Other Supplies Materials Media	2,200.00		453.73		1,746.27
490-Other Expenses	850.00	97.00	821.72		28.28
491-Dues and Fees	2,810.00		760.00		2,050.00
Total Expenditures	1,477,079.00	165,436.32	927,495.26		549,583.74

Chatham School District
Revenue & Expense Accounts
 Budget vs Actual - Actual, Encumbrance
 For the Period from February 1, 2024 to February 29, 2024

Fund: 100-General Fund (100), Fund Class: Unrestricted (UNRESTRICT)

School: Gustavus (062)

	Annual Budget	Period To Date - Actual	Year To Date - Actual	Year To Date - Encumbrance	Budget Remaining
Total Revenue					
313-Certified Principal	69,000.00	7,666.67	38,333.35		30,666.65
315-Certified Teacher	370,635.00	32,988.14	208,390.17		162,244.83
316-Certified Extra Duty Pay	13,000.00	1,620.00	10,270.00		2,730.00
323-Non-Certified Aide	94,043.00	6,102.41	40,246.78		53,796.22
324-Non-Certified Support Staff	31,842.00	1,798.20	18,355.53		13,486.47
325-Non Cert Maintenance Custodial	40,378.00	3,954.35	27,227.31		13,150.69
329-Non-Certified Substitute/Temp	22,000.00	1,425.69	8,444.23		13,555.77
361-Life/Health Insurance	160,300.00	14,436.00	86,136.37		74,163.63
362-Unemployment Insurance	2,432.00	558.58	2,829.79		-397.79
363-Workers' Compensation	7,854.00	837.83	5,296.00		2,558.00
364-FICA Contribution	20,963.00	1,548.34	10,454.44		10,508.56
365-TRS	115,512.00	5,309.71	32,278.34		83,233.66
366-PERS	41,730.00	2,608.08	18,882.50		22,847.50
369-Other Employee Benefits	2,000.00				2,000.00
410-Professional Technical Service	10,500.00	477.78	9,545.43		954.57
420-Staff Travel & Per Diem	7,000.00	371.10	3,465.70		3,534.30
425-Student Travel	60,000.00	2,306.10	20,817.29		39,182.71
431-Water & Sewer	26,000.00	12.47	12.47		25,987.53
432-Garbage	2,800.00	860.00	1,943.44		856.56
433-Communications	101,500.00	9,842.72	62,050.15		39,449.85
436-Electricity	35,000.00	2,411.30	13,771.40		21,228.60
438-Heating Fuel	53,000.00	6,497.40	21,989.62		31,010.38
440-Other Purchased Services	750.00				750.00
441-Rentals/Leases	9,000.00		165.60		8,834.40
442-Building Repair & Maintenance	5,000.00	3,044.37	5,446.47		-446.47
443-Equipment Repair & Maintenance	5,000.00	6,091.56	9,412.04		-4,412.04
446-Property Insurance	23,453.00		22,716.25		736.75
450-Supplies	11,500.00	70.80	31,521.18		-20,021.18
452-Maintenance Supplies	3,000.00		1,532.55		1,467.45
453-Janitorial Supplies	4,000.00		3,025.32		974.68
454-Office Supplies	2,000.00	553.18	3,471.07		-1,471.07
458-Vehicle Gasoline, Diesel, Oil	250.00		287.48		-37.48
471-Textbooks	1,000.00	226.67	13,608.32		-12,608.32

Chatham School District
 Revenue & Expense Accounts
 Budget vs Actual - Actual, Encumbrance
 For the Period from February 1, 2024 to February 29, 2024

Fund: 100-General Fund (100), Fund Class: Unrestricted (UNRESTRICT)
 School: Gustavus (062)

	Annual Budget	Period To Date - Actual	Year To Date - Actual	Year To Date - Encumbrance	Budget Remaining
472-Library Books	500.00				500.00
490-Other Expenses	800.00		1,342.67		-542.67
491-Dues and Fees	2,560.00		1,180.00		1,380.00
Total Expenditures	1,356,302.00	113,619.45	734,449.26		621,852.74

Chatham School District
Revenue & Expense Accounts
 Budget vs Actual - Actual, Encumbrance
 For the Period from February 1, 2024 to February 29, 2024

Fund: 100-General Fund (100), Fund Class: Unrestricted (UNRESTRICT)
 School: Correspondence Program (064)

	Annual Budget	Period To Date - Actual	Year To Date - Actual	Year To Date - Encumbrance	Budget Remaining
Total Revenue					
321-Director/Coordinator/Mgr	62,000.00	5,270.00	26,350.00		35,650.00
323-Non-Certified Aide	16,721.00	2,507.71	11,654.78		5,066.22
324-Non-Certified Support Staff	24,490.00	2,038.37	11,464.47		13,025.53
325-Non Cert Maintenance Custodial	6,477.00	693.28	5,444.96		1,032.04
329-Non-Certified Substitute/Temp	2,250.00				2,250.00
361-Life/Health Insurance	33,000.00	2,834.13	14,170.65		18,829.35
362-Unemployment Insurance	725.00	105.09	394.98		330.02
363-Workers' Compensation	1,398.00	157.65	823.71		574.29
364-FICA Contribution	8,565.00	803.97	4,200.97		4,364.03
366-PERS	25,906.00	1,954.37	9,882.47		16,023.53
369-Other Employee Benefits	500.00				500.00
410-Professional Technical Service	1,700.00		8,247.32		-6,547.32
420-Staff Travel & Per Diem	3,100.00		100.00		3,000.00
432-Garbage	50.00				50.00
433-Communications	40,500.00	6,040.52	37,200.92		3,299.08
438-Heating Fuel	19,000.00	3,041.01	9,423.82		9,576.18
440-Other Purchased Services	26,000.00	8,741.26	24,754.23		1,245.77
441-Rentals/Leases	1,500.00				1,500.00
442-Building Repair & Maintenance	2,000.00	366.67	366.67		1,633.33
443-Equipment Repair & Maintenance	1,350.00		250.00		1,100.00
446-Property Insurance	14,590.00		13,357.71		1,232.29
450-Supplies	2,000.00	189.93	350.00		1,650.00
452-Maintenance Supplies	1,000.00				1,000.00
453-Janitorial Supplies	500.00				500.00
454-Office Supplies	100.00				100.00
490-Other Expenses	6,000.00		3,303.36		2,696.64
491-Dues and Fees	750.00		135.00		615.00
Total Expenditures	302,172.00	34,743.96	181,876.02		120,295.98

Chatham School District

Revenue & Expense Accounts

Budget vs Actual - Actual, Encumbrance

For the Period from February 1, 2024 to February 29, 2024

Fund: 100-General Fund (100), Fund Class: Unrestricted (UNRESTRICT)

School: Correspondence Program (064)

Annual Budget	Period To Date - Actual	Year To Date - Actual	Year To Date - Encumbrance	Budget Remaining
----------------------	------------------------------------	----------------------------------	---------------------------------------	-----------------------------

Chatham School District
Revenue & Expense Accounts
Budget vs Actual - Actual, Encumbrance
For the Period from February 1, 2024 to February 29, 2024

Fund: 100-General Fund (100), Fund Class: Unrestricted (UNRESTRICT)

School: Klukwan (067)

	Annual Budget	Period To Date - Actual	Year To Date - Actual	Year To Date - Encumbrance	Budget Remaining
Total Revenue					
313-Certified Principal	7,000.00				7,000.00
315-Certified Teacher	85,000.00	10,491.32	62,947.92		22,052.08
316-Certified Extra Duty Pay			2,400.00		-2,400.00
323-Non-Certified Aide		1,355.45	7,564.82		-7,564.82
324-Non-Certified Support Staff	14,562.00	2,212.72	9,247.87		5,314.13
325-Non Cert Maintenance Custodial	43,820.00	3,531.15	25,794.54		18,025.46
329-Non-Certified Substitute/Temp	3,500.00	2,550.00	5,872.71		-2,372.71
361-Life/Health Insurance	68,240.00	4,133.61	26,067.98		42,172.02
362-Unemployment Insurance	915.00	205.92	1,158.72		-243.72
363-Workers' Compensation	3,568.00	308.85	1,738.88		1,829.12
364-FICA Contribution	5,728.00	924.72	4,782.14		945.86
365-TRS	23,478.00	1,317.70	8,207.64		15,270.36
366-PERS	14,652.00	1,413.63	9,225.37		5,426.63
410-Professional Technical Service	1,500.00	8,237.78	17,701.17		-16,201.17
420-Staff Travel & Per Diem	5,000.00	2,448.84	9,481.22		-4,481.22
431-Water & Sewer	3,375.00		540.00		2,835.00
432-Garbage	675.00		100.00		575.00
433-Communications	60,000.00	4,584.33	30,210.60		29,789.40
436-Electricity	42,000.00	3,854.49	17,748.20		24,251.80
438-Heating Fuel	60,000.00	14,597.50	33,400.40		26,599.60
440-Other Purchased Services	500.00				500.00
441-Rentals/Leases	4,500.00				4,500.00
442-Building Repair & Maintenance	2,000.00	1,378.85	1,905.06		94.94
443-Equipment Repair & Maintenance	6,000.00	2,485.58	2,485.58		3,514.42
446-Property Insurance	20,690.00		22,154.13		-1,464.13
450-Supplies	1,000.00		31,012.97		-30,012.97
452-Maintenance Supplies	1,500.00		6,448.54		-4,948.54
453-Janitorial Supplies	2,000.00	724.68	968.19		1,031.81
454-Office Supplies	500.00		605.96		-105.96
458-Vehicle Gasoline, Diesel, Oil	300.00	647.60	2,020.99		-1,720.99
471-Textbooks	500.00	226.66	11,737.70		-11,237.70
472-Library Books	250.00				250.00
479-Other Supplies Materials Media			250.00		-250.00

Chatham School District

Revenue & Expense Accounts

Budget vs Actual - Actual, Encumbrance

For the Period from February 1, 2024 to February 29, 2024

Fund: 100-General Fund (100), Fund Class: Unrestricted (UNRESTRICT)

School: Klukwan (067)

	Annual Budget	Period To Date - Actual	Year To Date - Actual	Year To Date - Encumbrance	Budget Remaining
490-Other Expenses	200.00		675.68		-475.68
491-Dues and Fees	50.00				50.00
Total Expenditures	483,003.00	67,631.38	354,454.98		128,548.02

Chatham School District
Revenue & Expense Accounts
 Budget vs Actual - Actual, Encumbrance
 For the Period from February 1, 2024 to February 29, 2024

Fund: 100-General Fund (100), Fund Class: Unrestricted (UNRESTRICT)

School: District Wide (099)

	Annual Budget	Period To Date - Actual	Year To Date - Actual	Year To Date - Encumbrance	Budget Remaining
Total Revenue					
311-Certified Superintendent	86,520.00	7,336.00	58,016.00		28,504.00
316-Certified Extra Duty Pay	60,775.00		12,400.00		48,375.00
324-Non-Certified Support Staff	154,583.00	14,934.03	118,936.32		35,646.68
329-Non-Certified Substitute/Temp	24,300.00	4,943.64	11,781.60		12,518.40
361-Life/Health Insurance	42,000.00	2,600.48	22,238.54		19,761.46
362-Unemployment Insurance	1,215.00	243.19	963.12		251.88
363-Workers' Compensation	4,740.00	364.79	3,069.63		1,670.37
364-FICA Contribution	15,819.00	1,695.87	11,635.49		4,183.51
365-TRS	37,588.00	921.40	8,844.24		28,743.76
366-PERS	41,303.00	3,285.49	26,166.00		15,137.00
369-Other Employee Benefits	1,000.00		5,215.74		-4,215.74
410-Professional Technical Service	247,338.00	1,002.76	15,928.75		231,409.25
412-Auditing Accounting Service	88,000.00		45,282.75		42,717.25
414-Legal Services	10,000.00	2,144.00	7,059.50		2,940.50
420-Staff Travel & Per Diem	40,500.00	4,237.29	26,791.08		13,708.92
433-Communications	17,000.00	595.86	3,151.82		13,848.18
436-Electricity	5,000.00	526.60	1,551.77		3,448.23
440-Other Purchased Services	1,250.00		15,151.16		-13,901.16
441-Rentals/Leases	5,000.00	295.11	885.33		4,114.67
442-Building Repair & Maintenance	500.00				500.00
443-Equipment Repair & Maintenance	1,250.00				1,250.00
446-Property Insurance	5,140.00		5,140.00		
447-Liability Insurance	42,080.00		44,417.46		-2,337.46
450-Supplies	3,100.00		372.02		2,727.98
452-Maintenance Supplies	100.00				100.00
454-Office Supplies	3,000.00	202.37	1,049.51		1,950.49
471-Textbooks			42.50		-42.50
490-Other Expenses	2,200.00	78.73	1,491.70		708.30
491-Dues and Fees	19,955.00	19,678.40	34,473.97		-14,518.97
495-Indirect Cost Recovery	-60,000.00		-56,172.15		-3,827.85
Total Expenditures	901,256.00	65,086.01	425,883.85		475,372.15

Chatham School District

Revenue & Expense Accounts

Budget vs Actual - Actual, Encumbrance

For the Period from February 1, 2024 to February 29, 2024

Fund: 100-General Fund (100), Fund Class: Unrestricted (UNRESTRICT)

School: District Wide (099)

Annual Budget	Period To Date - Actual	Year To Date - Actual	Year To Date - Encumbrance	Budget Remaining
----------------------	------------------------------------	----------------------------------	---------------------------------------	-----------------------------

CHATHAM SCHOOL DISTRICT
Memorandum Of Agreement
P.O. Box 109, Angoon, AK 99820 Phone 907-788-3302



Submitter Name

Jon Wunrow

Submitter Email

jwunrow@chatham.sd.org

This Service Agreement is between the Chatham School District and the below-named Service Provider.

Service Provider Name

Kootznoowoo

Service Provider Email Address

twilbur@kootznoowoo.com

Service Provider Phone Number

(907)790-2992

Service provider Business License#

XX

Mailing Address

8585 Old Dairy Road, STE 104 Juneau, AK. 99801

Social Security or Tax ID Number

XX

Upload W9 Form Here

Service Agreement.pdf

Start Date

10/01/2023

End Date

02/28/2024

The Service Provider Agrees to do the Following:

Classroom and experiential training and activities, that focus on preparing youth to serve as wildlife and wilderness guides; planning for the 2024 Angoon guide academy, purchase and proper use and storage of outdoor equipment and supplies; exposure to commercial guiding operations, and travel to training sites. To be done over a 5 month period.

Payment Terms

Total of \$46,000 to be paid upon invoice

Account Code

Amount to be paid

316-060-100-024-410 NACTEP

\$46,000

MOA not to Exceed This Amount

\$46,000

When Payment(s) Are to be Issued

Upon Invoice

Additional Conditions/ProvisionsA - GENERAL INFORMATION

1. All associated costs, not limited to fees and reimbursables, must be included in the MOA. All MOA's for more than \$25,000 require prior School Board approval before the Contractor provides any service.
2. The account to be charged must be determined and approved by the individual with budget authority before submission of the MOA to the Superintendent.
3. Before the starting date of the contracted services and/or activities, the Contractor and Chatham School District must sign the MOA. The Contractor is not to be given a notice to proceed unless all the appropriate parties have signed the MOA.
4. The Contact Person will be responsible for obtaining the contractor's signature and submitting the original MOA to the Superintendent.
5. The Contact Person must approve for payment of all contractor invoices and receipt documentation before submission for payment to Accounts Payable.
6. When the MOA involves travel paid by Chatham School District; a Travel Authorization must accompany any invoice.
7. Any Chatham School District employee who authorizes services before the required approvals may be subject to disciplinary action up to and including termination.

B - CONTRACTOR RESPONSIBILITIES

1. Check the MOA for contents and completeness. If the terms are agreeable, sign the agreement and return it to the individual named as the Contact Person.

In accordance with the payment terms set forth on page 1, the Contractor shall submit an invoice with the appropriate documentation (copies of airline tickets, hotel bills, etc.) to the Contact Person for approval of payment.

As a condition of performance, the Contractor must pay all federal, state, and local taxes incurred by the Contractor.

A W-9 must be on file with Chatham School District or submitted with this MOA. No W-9, backup withholding of Federal taxes will be withheld per the percent required – presently 29%.

The Contractor must provide proof of any liability insurance coverage required on this MOA.

To the extent allowed by law, the Contractor shall indemnify, defend, and hold Chatham School District harmless from any liability resulting from or arising out of the acts of the Contractor in the performance of this MOA.

I HEREBY ACCEPT THIS MOA AND THE CONDITIONS/PROVISIONS CONTAINED HEREIN. Any changes in the terms of this MOA must be on an ADDENDUM FORM before any services are performed. The ADDENDUM FORM must be approved by all parties.

Submitter Signature

Michelle Shatswell

Submitter Comments

This will be on the next board meeting for

Service Provider Signature

Thomas E. Willbur, CEO

Superintendent Signature

Ralph Watkins

Purchase Agreement

This Purchase Agreement is made as of the date signed below by and between Chatham School District ("Seller") and __Ela and Janusz Kunat__ ("Buyer") that Seller agrees to sell to Buyer all equipment, food, and supplies of the Foxes Den Restaurant. . Accordingly, it is agreed as follows:

1. Sale of Assets. Seller shall sell the Foxes Den Restaurants equipment, food, and supplies (collectively referred to as the "Assets") to Buyer for \$25,000 in cash. Transfer of the Assets shall occur upon signature of this agreement. The buyer makes the \$25,000 payment in full by June 1st 2024. Multiple payments shall be accepted as long as it is paid in full by June 1st.
2. AS-IS Sale. The Assets are being transferred "AS-IS", and Seller makes no representations or warranties, express or implied, with regard to the merchantability, quality or fitness for a particular purpose of said Assets in any respect whatsoever. Buyer understands and is willing to take on any maintenance and supply costs that are associated with the Assets. Buyer also acknowledges that the physical building that the Foxes Den Restaurant has occupied is not owned by Owner and Buyer will need to negotiate a lease with the Owner.
3. Liability and Indemnification. Seller shall not be liable for any of Buyer's liabilities related to the Assets after the date of donation. Buyer shall indemnify and hold harmless Seller in respect of any losses, claims, demands, liability, suits, judgments, costs and expenses, including reasonable accounting costs and costs of legal representation, of whatever kind or nature imposed upon, incurred by or assessed against Seller by reason of the ownership or operation of the Assets after the sale
- 4.
5. Entire Agreement. This Agreement constitutes the entire agreement between the parties with respect to the Assets.

6. Separate Counterparts. This Agreement may be executed in several identical counterparts each of which shall be deemed an original, but all of which together shall constitute one and the same instrument.

IN WITNESS WHEREOF, the parties have executed this Agreement as of the date first above written.

CHATHAM SCHOOL DISTRICT

By Ralph Walker

Its Superintendent

Mama Bear Kitchen LLC

By Jennifer Kinnel March 06 2024

Its member

Foxes Den Equipment Supplies List February 2024

20' Connex
200# Propane Tank
Outdoor tables and chairs(2 tables and 7 chairs)
1 Picnic Table
Hisense Chest Freezer
Whirlpool Chest Freezer
Kenmore Chest Freezer
Kenmore Upright Freezer
GE Upright Freezer
Crosley Refridgerator
True Double Door Cooler
True Beverage Cooler
Danby Mini Fridge
Beverage-Air double door prep cooler w/prep cutting board
True single-door prep coolers w/prep cutting board
New Gas Range with Griddle
New Deep Fryer
Stainless steel prep table 30"W x 36" L
2 Blodgett pizza ovens
Boos block butcher block table
Spar 30qt mixer with attachments
6 metal shelving units
2 Compartment sink with Dishwasher
New Automatic Grease Trap
Prep sink
Handwashing sink
Bunn coffee maker
Vollrath Slicer
French Fry Cutter
Kel Max Speed Rack
Emerson Microwave
CanOpener
Wall-mounted ketchup dispenser
5 square tables
5 round tables
35 chairs
Highchair
2 booster seats
Dish cart with dish bins
Dish racks
Mop bucket
Trash Cans

CONNEX INVENTORY

Freezers

4 bagel
8 bags french toast sticks
13 bags hash browns
6 bags english muffins
2 cases sausage links
8 32oz sliced turkey
2 1.5lb sliced cheddar
2 24oz. Sliced provolone
1 40oz lima beans
15 sourdough bread
22 white bread
5 wheat bread
9 rye bread
2 hogi rolls
Case of hotdog bun
2 pack dogs
3 tortilla shell
9 1lb butter
2 5lb shredded cheddar
3 5lb pepperoni
1 peach cobbler
2 18 pack hot dogs
Cs guacamole singles
2 carrot cake
7 5lb shredded mozzarella cheese
2 5lb canadian bacon
7 5lb chunk chicken
3 5lb sausage crumbles
4 12dz hamber bun
5 dinner rolls

Cooler

2 cases whipped butter singles
Cs chicken base
1 5lb american cheese
4 swiss cheese
3 case swiss cheese (donated)
2 gl dill pickle spears (donated)
3 48oz cream cheese
3 5lb sour cream
2 ½gl heavy whipping cream

Food inventory

Dry foods

- 4 5lb pancake mix
- 7 1lb yeast
- 4 6lb cookie sprinkles
- 1 case brown gravy packets
- 1 case tabasco
- 1 26oz taco seasoning mix
- 18 cans cranberry sauce
- 3 bags powder milk
- 1 tapioca starch
- 1 case cocoa powder
- 1 basil container
- 1 black pepper
- 1 oregano
- 1 case ranch mix
- 1 case of raisin singles
- 5 1gl mixed oil
- 4 1gl mayonnaise
- 3 1gl baby rays bbq
- 4 #10 cans tomato sauce
- 1 #10 can roasted bell pepper
- 1 #10 artichoke
- 1 case 27oz. Green chili
- 7 28oz roasted bell pepper
- 1 21oz green olives
- 21 12oz. Cans tomato paste
- 2 10lb macaroni noodle
- 1 10lb try-color pasta
- 10lb long noodle
- 2 6lb Jalapenos
- 3 48oz. Honey
- 7 #10 country gravy
- ½ case au ju mix packet
- 5 20oz sliced pineapple
- 8 13oz mustard
- 1 20oz poppyseed
- 9 1lb pam spray
- 12 15oz red kidney bean
- 2 25lb flour
- 2 50lb white sugar
- ¾ case brown sugar
- 8 48oz dijon mustard

8 16oz parmesan cheese
5 1gal sweet relish
8 7lb ketchup
1 case plus 3 cans #10 pineapple tidbits
1 #10 can corn
9 #10 can olives
2 8pack razz-cranberry La Croux
1 8 pack peach-pear La Croux
2 24 pack diet coke
2 12 pack diet pepsi
1 12 pack Barqs root beer
Approx 10-15lb potato
Approx 10lb onions
4 #10 can nacho cheese
5 #10 garbanzo
 $\frac{3}{4}$ case sprite
15 mountain dew
1 4lb pepper flake
1 $\frac{1}{2}$ case Ice tea pouches
 $\frac{3}{4}$ case lemonade pouches
1 case mayonnaise singles
1 case mustard singles
 $\frac{1}{2}$ case brown sugar singles
1 case splenda singles
1 case coffee mate singles
 $\frac{1}{2}$ case equal
1 case sweet & low
2 cases sugar singles

Silver Fridge/freezer

4 bags vegetarian Chicken patty
7 bags garden burger
4 Gluten free pizza crust
1 vegetarian chicken tenders
4 16oz chicken base
 $\frac{1}{2}$ gal maple syrup
5 green leaf lettuce
20 tomatoes

Freezer 2 inside

4 gal bag green beans
6 gal bags peas & carrots
6 bags french toast sticks
9 gal bags cookie dough

2 gl bags individual guacamole
1 case turkey dogs
2 bags shredded mozzarella cheese
1 chicken poblano pepper soup
2 mash red potato
2 clam chowder
3 tomato bisque soup
1 shrimp & sausage gumbo soup
3 bag chicken tenders
3 bags chicken patties
¾ case burger patty
3 bags bacon bits
6 packs cheesecake
1 tiramisu

Back shelf supplies

½ case napkins
1 case lg to go
1 case 1.5oz cups
1 case 8oz soup cups to go
¾ case straw
1 case grease wraps

Utility closet/dish pit

23 paper towels
1 case + 3 packs toilet paper
1 gl hand soap
5 1gl daily floor cleaner
2 bottles restroom cleaner
6 1gl bleach
2 1gl dish soap
1 ¾ case sterimine
2 1gl rinse additive
1 ½ 1g wishmachine soap
2 2gl peroxide cleaner
1 2gl orange cleaner
1 2gl Oasis 100 cleaner
2 2gl wash and walk cleaner
1 gl windex
1 2gl glass cleaner
2 case mop head
2 mops
1 lg push broom
2 rolls of 33gl trash bags

2 case 12-16gl trash bags
1 case 10gl trash bags

10 35lb fryer oil

Neon open sign
5 sets of curtains
4 Anti-fatigue mats
2 floor mats
Cambros(different sizes)
Sheet pans
Assorted pots and pans
Frying pans
Soup pots
Small pizza pans
Large pizza pans
Pizza paddles
Pizza stands
Mixing bowls
Kitchen utensils
Cutting boards
2-rapid Kool plus
Pitchers
Colanders
Squeeze bottles with lids
Cups
Plates
Bowls
Soup Cups
Food baskets
Cake display
Measuring cups
Dry food storage bins
Silverware
Kitchen scale
Kitchen knives
Salt and pepper shakers
2 Serving trays
Cream and sugar dispensers
New Donut Row Machine
New Hot wire fence system
POS Square device for sales

Hood Vent for the stove(this was specially engineered and fitted to this building if it were to be removed it would require a great deal of contract work, and is recommended to leave it with the building)

CHATHAM SCHOOL DISTRICT

2024-25 School Calendar A

Notes:

Sep 02: Labor Day

Oct 14: Columbus Day

Oct 18: Alaska Day

Oct 31: Halloween

Nov 11: Veterans Day

Nov 28: Thanksgiving Day

Dec 25: Christmas Day

Jan 01: New Year's Day

Jan 20: M L King Day

Feb 16: Elizabeth Peratrovich Day

Day

Feb 17: Presidents' Day

Apr 18: Good Friday

Apr 20: Easter Sunday

May 11: Mother's Day

May 26: Memorial Day

Jun 15: Father's Day

Jul 04: Independence Day

August 2024

S	M	T	W	T	F	S
					1	2
				3	4	5
6	7	8	9	10	11	12
13	14	15	16	17	18	19
20	21	22	23	24	25	26
27	28	29	30	31		
13						

September 2024

S	M	T	W	T	F	S
1	2	3	4	5	6	7
8	9	10	11	12	13	14
15	16	17	18	19	20	21
22	23	24	25	26	27	28
29	30					
20						

October 2024

S	M	T	W	T	F	S
					1	2
				3	4	5
6	7	8	9	10	11	12
13	14	15	16	17	18	19
20	21	22	23	24	25	26
27	28	29	30	31		
22						

November 2024

S	M	T	W	T	F	S
					1	2
				3	4	5
			6	7	8	9
10	11	12	13	14	15	16
17	18	19	20	21	22	23
24	25	26	27	28	29	30
19						

December 2024

S	M	T	W	T	F	S
1	2	3	4	5	6	7
8	9	10	11	12	13	14
15	16	17	18	19	20	21
22	23	24	25	26	27	28
29	30	31				
15						

January 2025

S	M	T	W	T	F	S
						1
				2	3	4
5	6	7	8	9	10	11
12	13	14	15	16	17	18
19	20	21	22	23	24	25
26	27	28	29	30	31	
17						

February 2025

S	M	T	W	T	F	S
						1
						2
						3
						4
						5
						6
						7
						8
						9
						10
						11
						12
						13
						14
						15
16	17	18	19	20	21	22
23	24	25	26	27	28	
20						

March 2025

S	M	T	W	T	F	S
						1
						2
						3
						4
						5
						6
						7
						8
						9
						10
						11
						12
						13
						14
						15
16	17	18	19	20	21	22
23	24	25	26	27	28	29
30	31					
14						

April 2025

S	M	T	W	T	F	S
						1
						2
						3
						4
						5
						6
						7
						8
						9
						10
						11
						12
						13
						14
						15
						16
						17
						18
						19
						20
						21
						22
						23
						24
						25
						26
						27
						28
						29
						30
						31
21						

May 2025

S	M	T	W	T	F	S
						1
						2
						3
						4
						5
						6
						7
						8
						9
						10
						11
						12
						13
						14
						15
						16
						17
						18
						19
						20
						21
						22
						23
						24
						25
						26
						27
						28
						29
						30
						31
17						

June 2025

S	M	T	W	T	F	S
						1
						2
						3
						4
						5
						6
						7
						8
						9
						10
						11
						12
						13
						14
						15
						16
						17
						18
						19
						20
						21
						22
						23
						24
						25
						26
						27
						28
						29
						30
						31

July 2025

S	M	T	W	T	F	S
						1
						2
						3
						4
						5
						6
						7
						8
						9
						10
						11
						12
						13
						14
						15
						16
						17
						18
						19
						20
						21
						22
						23
						24
						25
						26
						27
						28
						29
						30
						31

Inservice Days	■
Teacher Work Days	■
Vacation Days	■
Holidays	■
End of Quarter	■
Parent Teacher Conferences	■
First day of school 8/20/24	_____
Last Day of school 5/23/25	_____

Days per Quarter: 1st Qtr 42, 2nd Qtr 42, 3rd Qtr 46, 4th Qtr 43

CHATHAM SCHOOL DISTRICT

Notes: 2024-25 School Calendar B (with additional Inservice days at the beginning)

Sep 02: Labor Day

Oct 14: Columbus Day

Oct 18: Alaska Day

Oct 31: Halloween

Nov 11: Veterans Day

Nov 28: Thanksgiving Day

Dec 25: Christmas Day

Jan 01: New Year's Day

Jan 20: M L King Day

Feb 16: Elizabeth Peratrovich Day

Day

Feb 17: Presidents' Day

Apr 18: Good Friday

Apr 20: Easter Sunday

May 11: Mother's Day

May 26: Memorial Day

Jun 15: Father's Day

Jul 04: Independence Day

August 2024

S	M	T	W	T	F	S
					1	2
				3	4	5
6	7	8	9	10	11	12
13	14	15	16	17	18	19
20	21	22	23	24	25	26
27	28	29	30	31		
	5					

September 2024

S	M	T	W	T	F	S
1	2	3	4	5	6	7
8	9	10	11	12	13	14
15	16	17	18	19	20	21
22	23	24	25	26	27	28
29	30					
			20			

October 2024

S	M	T	W	T	F	S
		1	2	3	4	5
6	7	8	9	10	11	12
13	14	15	16	17	18	19
20	21	22	23	24	25	26
27	28	29	30	31		
				22		

November 2024

S	M	T	W	T	F	S
					1	2
3	4	5	6	7	8	9
10	11	12	13	14	15	16
17	18	19	20	21	22	23
24	25	26	27	28	29	30
				19		

December 2024

S	M	T	W	T	F	S
1	2	3	4	5	6	7
8	9	10	11	12	13	14
15	16	17	18	19	20	21
22	23	24	25	26	27	28
29	30	31				
		15				

January 2025

S	M	T	W	T	F	S
			1	2	3	4
5	6	7	8	9	10	11
12	13	14	15	16	17	18
19	20	21	22	23	24	25
26	27	28	29	30	31	
			17			

February 2025

S	M	T	W	T	F	S
						1
2	3	4	5	6	7	8
9	10	11	12	13	14	15
16	17	18	19	20	21	22
23	24	25	26	27	28	
				20		

March 2025

S	M	T	W	T	F	S
						1
2	3	4	5	6	7	8
9	10	11	12	13	14	15
16	17	18	19	20	21	22
23	24	25	26	27	28	29
30	31					14

April 2025

S	M	T	W	T	F	S
		1	2	3	4	5
6	7	8	9	10	11	12
13	14	15	16	17	18	19
20	21	22	23	24	25	26
27	28	29	30			
				21		

May 2025

S	M	T	W	T	F	S
				1	2	3
4	5	6	7	8	9	10
11	12	13	14	15	16	17
18	19	20	21	22	23	24
25	26	27	28	29	30	31
				17		

June 2025

S	M	T	W	T	F	S
1	2	3	4	5	6	7
8	9	10	11	12	13	14
15	16	17	18	19	20	21
22	23	24	25	26	27	28
29	30					

July 2025

S	M	T	W	T	F	S
		1	2	3	4	5
6	7	8	9	10	11	12
13	14	15	16	17	18	19
20	21	22	23	24	25	26
27	28	29	30	31		

Inservice Days	■
Teacher Work Days	■
Vacation Days	■
Holidays	■
End of Quarter	■
Parent Teacher Conferences	■
First day of school 8/20/24	_____
Last Day of school 5/23/25	_____

Days per Quarter: 1st Qtr 43, 2nd Qtr 38, 3rd Qtr 46, 4th Qtr 43

CHATHAM SCHOOL DISTRICT

Notes: 2024-25 School Calendar C (with additional Inservice days at the beginning)

Sep 02: Labor Day

Oct 14: Columbus Day

Oct 18: Alaska Day

Oct 31: Halloween

Nov 11: Veterans Day

Nov 28: Thanksgiving Day

Dec 25: Christmas Day

Jan 01: New Year's Day

Jan 20: M L King Day

Feb 16: Elizabeth Peratrovich Day

Feb 17: Presidents' Day

Apr 18: Good Friday

Apr 20: Easter Sunday

May 11: Mother's Day

May 26: Memorial Day

Jun 15: Father's Day

Jul 04: Independence Day

August 2024

S	M	T	W	T	F	S
				1	2	3
4	5	6	7			
11	4	5	6	7		
18	12	13	14	15	16	24
25	19	20	21	22	23	31
	26	27	28	29	30	

September 2024

S	M	T	W	T	F	S
1	2	3	4	5	6	7
8	9	10	8	9	10	11
15	16	17	18	19	20	21
22	23	24	25	26	27	28
29	30					

October 2024

S	M	T	W	T	F	S
			1	2	3	4
5	6	7	8	9	10	11
13	14	15	16	17	18	19
20	21	22	23	24	25	26
27	28	29	30	31		

November 2024

S	M	T	W	T	F	S
					1	2
3	4	5	6	7	8	9
10	11	12	13	14	15	16
17	18	19	20	21	22	23
24	25	26	27	28	29	30

13

20

22

19

December 2024

S	M	T	W	T	F	S
1	2	3	4	5	6	7
8	9	10	11	12	13	14
15	16	17	18	19	20	21
22	24	25	26	27	28	
29	30	31				

January 2025

S	M	T	W	T	F	S
			1	2	3	4
5	6	7	8	9	10	11
12	13	14	15	16	17	18
19	20	21	22	23	24	25
26	27	28	29	30	31	

February 2025

S	M	T	W	T	F	S
						1
2	3	4	5	6	7	8
9	10	11	12	13	14	15
16	17	18	19	20	21	22
23	24	25	26	27	28	

March 2025

S	M	T	W	T	F	S
						1
2	3	4	5	6	7	8
9	10	11	12	13	14	15
16	17	18	19	20	21	22
23	24	25	26	27	28	29
30	31					

15

17

20

14

April 2025

S	M	T	W	T	F	S
		1	2	3	4	5
6	7	8	9	10	11	12
13	14	15	16	17	18	19
20	21	22	23	24	25	26
27	28	29	30			

May 2025

S	M	T	W	T	F	S
				1	2	3
4	5	6	7	8	9	10
11	12	13	14	15	16	17
18	19	20	21	22	23	24
25	26	27	28	29	30	31

June 2025

S	M	T	W	T	F	S
1	2	3	4	5	6	7
8	9	10	11	12	13	14
15	16	17	18	19	20	21
22	23	24	25	26	27	28
29	30					

July 2025

S	M	T	W	T	F	S
		1	2	3	4	5
6	7	8	9	10	11	12
13	14	15	16	17	18	19
20	21	22	23	24	25	26
27	28	29	30	31		

21

17

Days per Quarter: 1st Qtr 42, 2nd Qtr 38, 3rd Qtr 41, 4th Qtr 43

Inservice Days	■
Teacher Work Days	■
Vacation Days	■
Holidays	■
End of Quarter	■
Parent Teacher Conferences	■
First day of school 9/3/24	_____
Last Day of school 5/23/25	_____

CHATHAM SCHOOL DISTRICT
Memorandum Of Agreement
P.O. Box 109, Angoon, AK 99820 Phone 907-788-3302



Submitter Name

Jon Wunrow

Submitter Email

jonwunrow@gmail.com

This Service Agreement is between the Chatham School District and the below-named Service Provider.

Service Provider Name

Kootznawoo INC

Service Provider Email Address

twilbur@kootznoowoo.com

Service Provider Phone Number

9077902992

Service provider Business License#

XXX

Mailing Address

8585 Old Dairy Road, STE 104 Juneau, AK. 99801

Social Security or Tax ID Number

XXX

Upload W9 Form Here

Service Agreement.Kootznoowoo....

Start Date

09/01/2023

End Date

02/28/2024

The Service Provider Agrees to do the Following:

Provide the following educational services to Students: classroom instruction in traditional Tlingit art, including beading, form-line drawing, weaving, carving, moccasin making, and other classes yet to be determined. Up to 15 students will be able to receive these services. Chatham School District expects that Students receiving educational services from Service Provider will demonstrate knowledge and skills learned in various traditional art forms including weaving, carving, form-line

Payment Terms

This total amount will be used for: instructor costs, supplies, instructor travel, purchase and installation

Account Code

Amount to be paid

316-060-100-024-410 NACTEP

\$55,886.00

MOA not to Exceed This Amount

\$55,886.00

When Payment(s) Are to be Issued

As Invoiced

Additional Conditions/ProvisionsA - GENERAL INFORMATION

1. All associated costs, not limited to fees and reimbursables, must be included in the MOA. All MOA's for more than \$25,000 require prior School Board approval before the Contractor provides any service.
2. The account to be charged must be determined and approved by the individual with budget authority before submission of the MOA to the Superintendent.
3. Before the starting date of the contracted services and/or activities, the Contractor and Chatham School District must sign the MOA. The Contractor is not to be given a notice to proceed unless all the appropriate parties have signed the MOA.
4. The Contact Person will be responsible for obtaining the contractor's signature and submitting the original MOA to the Superintendent.
5. The Contact Person must approve for payment of all contractor invoices and receipt documentation before submission for payment to Accounts Payable.
6. When the MOA involves travel paid by Chatham School District; a Travel Authorization must accompany any invoice.
7. Any Chatham School District employee who authorizes services before the required approvals may be subject to disciplinary action up to and including termination.

B - CONTRACTOR RESPONSIBILITIES

1. Check the MOA for contents and completeness. If the terms are agreeable, sign the agreement and return it to the individual named as the Contact Person.

In accordance with the payment terms set forth on page 1, the Contractor shall submit an invoice with the appropriate documentation (copies of airline tickets, hotel bills, etc.) to the Contact Person for approval of payment.

As a condition of performance, the Contractor must pay all federal, state, and local taxes incurred by the Contractor.

A W-9 must be on file with Chatham School District or submitted with this MOA. No W-9, backup withholding of Federal taxes will be withheld per the percent required – presently 29%.

The Contractor must provide proof of any liability insurance coverage required on this MOA.

To the extent allowed by law, the Contractor shall indemnify, defend, and hold Chatham School District harmless from any liability resulting from or arising out of the acts of the Contractor in the performance of this MOA.

I HEREBY ACCEPT THIS MOA AND THE CONDITIONS/PROVISIONS CONTAINED HEREIN. Any changes in the terms of this MOA must be on an ADDENDUM FORM before any services are performed. The ADDENDUM FORM must be approved by all parties.

Submitter Signature

Michelle Shatswell

Submitter Comments

This will be on the next board meeting for

Service Provider Signature



P.O. BOX 109 PHONE: 788-3302 or 788-3682 ANGOON, ALASKA 99820 FAX: 788-3252

email:rwatkins@chathamsd.org

To: Chatham Regional School Board
From: Superintendent Ralph Watkins
Regular Board Meeting Report

March 2024 Superintendent Board Report

Superintendent's Office

Superintendent Travel Calendar

March:

- 2/29-3/2 Gustavus Site Visit
- 3/15 Admin Retreat Virtual via Zoom
- 3/18-3/24 Spring Break

April:

- 4/1- 4/5 Klukwan Site Visit
- 4/22- 4/26 Tenakee Site Visit

May:

- 5/19 Gustavus Graduation
- 5/24 Last Day of School
- 5/25 Teacher Work Day

Department Reports

Food Service

Curriculum and Instruction

Facilities and Maintenance

Johnson Controls

There are two outstanding issues related to maintenance that need to be addressed. The most pressing is the Fire Panel in the Angoon elementary school. I recently spoke with Johnson Controls on how to best address the situation. As a reminder of how we got to the place we are in today I am providing a little background. After an inspection it was recommended that the fire panels in all of our schools be upgraded. A proposal was

submitted and accepted from Johnson Controls to complete the work. I am a little unclear as to how this was being funded. I recall a discussion about using COVID monies but have been unable to find anything in the minutes that clearly specifies this. In any case no money from COVID funds were spent on this project and there are no funds left to complete the work. That being the case we are left with an outstanding balance from the work in Tenakee is close to completion. The remaining items are a pull station that is required next to the exit upstairs, and for monitoring using a voice dialer which was approved by the fire marshal. There is also labor in here for our tech to commission what is left namely, install the pull station, and voice dialer, and design and PM time to bring it all together. The cost to finish the remaining work is \$7,914.16. For the work that has been completed in Tenakee there is an outstanding balance of \$35,403.73. I am including the work orders along with the cost for the projects in Gustavus, Angoon, and Klukwan. The amounts are: \$7,914.61 for the remaining work in Tenakee plus the outstanding 35K, Angoon which is a priority because we currently don't have a functioning fire panel is \$47,689.15, Gustavus is \$ 49,849.12, and Klukwan is \$81,427.04. The total to complete all the work and cover the outstanding balance is \$221,283.65. At the time of this report a \$5000 payment has been made to the outstanding balance. The question before the board is how do we move forward? We need to pay the outstanding balance and complete the work in Tenakee before the permits run out. I recommend authorizing the work for Tenakee immediately. We are making payments on the outstanding balance. Johnson Controls would prefer payment in full but until such time as that can happen we will continue to pay down the balance monthly. Secondly, we need to complete the work in Angoon since we do not have a working fire panel. Lastly, we can schedule out the work incrementally at the other sites as funds become available.

Gustavus Septic

The septic tank issue was recently brought to my attention during my recent visit to Gustavus. Here is what I know based on correspondence from the engineer: It appears there is an issue with the pressure sensor that determines the liquid level on the basin and thereby tells the pumps when to come on and off (and one pump is previously deceased). The level sensor is integral to the above ground panel that runs everything. The original pumps are no longer being manufactured and when the company was contacted as to a compatible replacement they sent drawings that do not look like they would attach to this current rail system. If we can't find an electrical engineer who understands how to program the panel that is currently installed, we can do away with the complicated control panel (that requires the company that built it to fix it) in favor of an off the shelf control panel utilizing standard float switches to work (and not the complex pressure switch type now employed). As the float switches are readily available - Toshco has carried them at times - these can be repaired here in the field. With a spare pump and float on hand a repair could be done that day. This change would be a bit more expensive. The original cost of installation in 2007 was \$22,580. I spoke with Mark and agreed that adding 20% to this cost for inflation may give a more reasonable cost estimate. Currently the problem is being mitigated via manually turning the pump on and off.

Business Office

Grants

The grant committee continues to meet weekly. Angoon High School is moving forward on several important vocational training projects including: delivery and setup of a Woodmizer Wood Mill. Training dates for Mill operators are still being worked out. And setup of a computer lab space and heavy equipment simulators.

Several traditional art classes have been held in partnership with Kootznoowoo, Inc. including two-needle beading, moccasin making, and form-line drawing. Additional classes are being scheduled, including a multi-week weaving class led by Shgen George. All classes are offered at no charge to Angoon students. A 2024 Angoon Guide Academy is also being developed in partnership

with Kooootznoowoo, Inc. Youth guide training, along with the traditional art program, are components of the NACTEP vocational grant that the District receives.

The Tlingit Language and Culture grant is providing funding for several important programs that are taking place both in Klukwan, and Angoon schools.

Grant managers have requested to start receiving monthly detailed financial reports from the District's bookkeeper. This will allow grant managers to pay closer attention to ensure that grant funds are spent in a timely and authorized manner.

Sped Director:

We have a total of 43 students on IEP's in the Chatham School District, 6 intensives. Sped director will attend the Sped Director training in Anchorage March 25 and 26th. She attended the ASSEC conference and met with providers to establish and continue a good working relationship that will strengthen our delivery of services model. Spoke with many vendors and organizations that will benefit transition age students with career pathways, job services and connect with DVR and their services. Sped director will meet with SAIL (Southeast Alaska Independent Living), next week to discuss connecting with DVR , summer work programs and activities for employment and independent living for post secondary students on IEP's. Spoke with Jim Kreatsman (DVR) to set up referrals for students of transition age (16 and older). We spoke of having students attend a transition camp in Juneau that DVR would be able to fund.

Human Resource

Klukwan Staffing

I wanted to provide some context for the discussion about adding an additional teacher for Klukwan. I will preface this with the understanding that there is significant cost involved in this request. With the uncertainty around the state budget many discussions in board rooms are around cutting staff. It should also be noted that we have not in any significant way started our budget discussion so there are many unanswered questions. However, the evidence in support of this addition is strong. Historically, there was a point in time that there were 3 teachers in klukwan. As the teaching staff was reduced, so was the enrollment. Currently we are on a very positive upswing. Our current enrollment is 17 K-8 students and 7 preschool students. Four of which will be moving to Kindergarten next year. We are projecting 25+ students based on current enrollment and waiting list. We are receiving multiple phone calls inquiring about enrollment for next year. We have opened up pre-enrollment beginning March 11th as we are anticipating having to cut enrollment at 30. Currently our K-4 class is at capacity, preschool has a capacity of 10 which this year we are at 7 and will start the SY 25 at 3 anticipating 4 students moving to Kindergarten. We have room in 5-8 but next year we anticipate having 2 HS students. Things are growing but without another teacher we will be hard pressed to grow to a point where we are self-sustaining. We have stabilized staffing. All klukwan staff will be returning next year. Grants have allowed us to hire periphery and support staff to support our certified staff which is allowing for increased engagement and achievement. We have not discussed in much detail configurations or addressed the limited classroom space. However, the main question becomes how do we grow in the current configuration. The answer is, we can't. I look forward to questions and discussion.

- Staff Accounting

Open positions: Tlingit Language Aide in Angoon, Para in Angoon. Positions open for next year: Elementary teacher in Angoon.

The 5-8 position in Klukwan has been getting the salary paid for by the CIV this year. Next year the district will be paying the salary.

The Klukwan school has increased in student enrollment numbers and the class sizes have expanded to the point there will need to be an additional elementary teacher there for next school year.

Angoon Elementary

Mary Long	K-1	Type A Teacher Certification
*Alfie Asilom	2-3	Type A Teacher Certification
*Azal Galarosa	4-5	Type A Teacher Certification
**Mary Zika	Special Education Teacher	Type A Teacher Certification
Open Position	Para	
*Tali James	Para	
<i>Cheryl Jack</i>	Para	
Open position	Para	
*Stella Estrada	Library/Para	
Mariah James	Elementary Secretary	
*Gina Jim	Head Cook	
*Frank Joseph	Assistant Cook	
*Emma Demmert	Principal	Principal GR K-12

Angoon High School

*Lori Moore	Science	Type A Teacher Certification
<i>Fernan Lopez</i>	ELA	Type A Teacher Certification
<i>Reanna Kookesh</i>	Social Studies/History	Type A Teacher Certification
*Ivan Ramey	CTE	Type M Teacher Certification
*Chenera Johnson	Tlingit/STEAM	Goldbelt-Type M Teacher Certification (pending)
*Pauline Johnson	Tlingit Language	Type M Teacher
*Kyle Johnson Sr.	Para/STEAM	
Trina Bales	Para	
* <i>Natasha Bennum</i>	High School Secretary	
Sally Joseph	Filling in for Secretary	
*Frank Coenraad	FSCS Grant/Counselor	Type A Teacher Certification
*Noelle Willis-Jackson	Sped Para	
* David Lueck	Math Teacher	Type A Certification

Klukwan School

*Jennifer Marschke	K-4 Teacher	Type A Teacher Certification
*Tonya Clark	5-8 Teacher	Type A Teacher Certification
*Gina St Clair	Preschool	Type A Teacher Certification
*Joleen Hotch	Para	
*Justina Hotch	Tlingit Language Teacher	Elementary Teacher Certification
*Darrel Jerue	Maintenance/Custodian	
*Rita Brouillette	School Secretary	
* Clara Natonabah	FSCS Grant Coordinator	

*Christopher Peterson Para Title I
 *Karlie Spud Tlingit Language Aide
 *Casey Rard Bus Driver/Student Transportation
 Jessie Morgan Tlingit Language Aide **New Hire**
 Alaina Birkel Paraprofessional **New Hire**

Tenakee Springs ILC

*Alice Carter, Preschool No Certification
 *Nikita Chase, Custodian
 *J.T. Collins, Maintenance
 *Linnea Lospenosochatel, Secretary
 *Megan Moody, Distance Education Coordination
 *Rick Petersen, Director of Distance Learning

Gustavus School

*Danielle Patrick, Secretary
 *Janice Byerlee, K-2 Teacher Type A Teacher Certification
 **Jesse Soder , 3-5 Teacher Type A Teacher Certification
 *Susan Collins , K-12 Special Education Type A Teacher Certification/Special Ed
 **Megan Bishop, 6-12 Sci & PE Type A Teacher Certification
 *Ronald Benkelman, 6-12 Math Type A Teacher Certification
 *Wendy Levy , 6-12 SS, English, Social Studies Type A Teacher Certification
 *Quynn Thompson, PreSchool Type E Teacher Certification
 *Steve Ilg CTE Type A Teacher Certification
 *Tracy Lowell, Special Education Paraprofessional
 *Paul Dzubay, Special Education Paraprofessional
 *Morgan Peterson-Park, Special Education Paraprofessional and Indian Education Tutor
 *Jeff Irwin, Maintenance
 *Teresa Terkelson, Custodian
 *Karen McSpadden, Principal and Sped Director Principal GR K-12/
 Rebecca Swanson Foxes Den Manager Last Day 3/8
 Leann Mattson Assistant Manager at Foxes Den Last day 3/8

District Office

*Michelle Shatswell HR Director and Administrative Asst to Supt
 *Sheri Singson District Office Secretary
 *Raynelle Jack Accounts Payable
 *Tanya Salmi STEPS and FSCS Grant Coordinator

Administration

Site Report

Angoon

Angoon basketball teams traveled to Hoonah for their final conference games and then Ketchikan for regionals where they represented Angoon Schools. They ended the season with a bang where they played their best.

We are gearing up for our second annual summer job fair. I have talked to various entities around the city and have been able to secure over 30 summer job positions for the students. We are preparing their resumes, letters of recommendation, and cover letters and putting them in a portfolio. All required documentation will be ready for the job fair on April 18-19. Students will be required to set up 3 interviews with potential employers at the fair. They will be prepped for the interview process and will need to dress professionally when showing up for interviews.

The Angoon teachers of planned some fun literacy activities for this month:

Literary Gallery

Contest Day: April 4, 2024, Thursday, @4PM

Goal: Present a summary and reflection about the book(s) read using a poster.

Spelling Bee

Contest Day: April 3, 2024, Wednesday, @4PM

Goal: Promote and celebrate linguistic skills, specifically spelling proficiency, among participants.

Poetry Writing Contest

Contest Day: April 1, 2024, Monday, @3:45 PM

Goal: Showcase abilities in creative writing and critical thinking

Character Portrayal

Contest Day: April 5, 2024, Friday, 5th period, and the rest of the day

Goal: Showcase abilities in creative public speaking and critical thinking

Battle of the Books using Kahoot!

Contest Day: April 2, 2024, Tuesday, @4PM

Goal: Showcase mastery in comprehension and critical thinking

Reading Month Challenge

Contest Day: March 4, 2024 - April 4, 2024

Drawing of Winners: April 5, 2024 during the Culminating Activity

Goal: To encourage people of all ages to read more books.

Read a 100 Challenge

Contest Day: March 4, 2024 - April 4, 2024

Drawing of Winners: April 5, 2024 during the Culminating Activity

Goal: To motivate elementary students to keep track of the books they read.

Gustavus:

3/12/24

We are excited to announce an upcoming opportunity for students in grades 10-12 to participate in the ASVAB assessment on Tuesday, March 12th. This assessment presents a valuable chance for our students to

explore their career options and gain insights into their skills and interests. The ASVAB assessment serves as an excellent starting point for career planning by helping students identify their strengths and areas for improvement. Following the assessment, there will be a post-test interpretation session, which will be crucial in helping students understand their ASVAB scores and how they can utilize them in shaping their future career paths. Overall, academic progress remains positive, with athletes consistently meeting grade requirements to participate in sports. No athletes have been ineligible to play sports so far this year, and efforts will continue to ensure their academic success.

Attendance:

Attendance rates are good, though some students struggle to catch up after long vacations. Efforts are underway to leverage Google Classroom for remote learning, but challenges with access to Wi-Fi sometimes require resorting to traditional methods of instruction.

Athletics:

The basketball team recently returned from regionals, with Bodin Todd winning a sportsmanship award and Tucker Kelly making all-conference. Track started the week of 3/4/24.

Calendars and Graduation: Calendars for the next academic year have been sent out for approval. Graduation for seniors is scheduled for Sunday, May 19th.

Challenges and Solutions:

Challenges persist with maintaining the open gym due to rule violations and improper storage of sports equipment. Consideration is being given to implementing locks in problem areas and storing certain items off-limits to prevent misuse.

Upcoming Events:

Jessie Soder has received approval from the superintendent for The Point Hike. This is a recurring hike that is being reintroduced to Gustavus School and principal will attend the event.

ASVAB Testing will be conducted on 3/12/24 in Gustavus. Students who are interested will take the assessment and a follow up will be directly after.

Ralph Watkins came to Gustavus last week and said he “really liked what we’re doing here.” He offered a roundtable in which there were approximately 20 parents and community members in attendance. While he didn’t have a formal agenda he discussed following the district’s strategic plan, Foxes Den, retaining teachers and support staff and considered ideas from the public. As far as a new gym which was briefly discussed, he did not think it was likely going to happen in the near future. There were many ideas from the forum that the superintendent said he will be exploring, one was how a para who has insurance has to pay a premium on the months they do not work. He said he would look into this.

The student council planned a pep rally for all students and the team traveling from Hoonah. I am proud of Gustavus student council, they have become the heartbeat of the school each one feeling an important task at their jobs and decisions they make for the whole school. The student store is a hit and we will have to be

ordering more items in the near future. Pep rallies have been thoughtfully planned and have included many games for the whole school in mind. The student council has a maturity about them way beyond their years. I believe living in an area where they have to be resourceful and sustaining is a gift and the reason for success.

We held a fundraiser during our game against Hoonah which was a half court basketball shoot in which the community got involved, noone made the shot but it was a fun activity for everyone. The principal and Language Arts teachers attended the RTI conference last week, it was a great opportunity to spend time with other teachers and reflect on the various sessions. Ralph had a debriefing session and teachers from the district were asked for takeaways from the sessions they attended.

CTE teacher has developed a tracking program through AKCIS that will monitor and track activity related to endeavors towards life after high school. It will track all classes taken in accordance with desired outcomes. Currently the teacher is working with students in all trades classes with OSHA safety courses.

Basketball team from Hoonah met in Gustavus and won both games, it was good competition and both teams gave great effort. Gustavus met Angoon in Angoon and although very close games, Angoon came out on top, Gustavus gave great effort and proved to be a contender with only four players the last minutes of the second game losing by only 3 points.

All Gustavus teachers have signed contracts SY 2024-25.

Student Count 59

Preschool-6
Kindergarten-3
1st-3
2nd-4
3rd-9
4th-3
5th-2
6th-2
7th-5
8th-3
9th-7
10th-7
11th-2
12th-3

Klukwan

[Great article about Klukwan School](#)

Student Count 16

Preschool-3

Kindergarten-1

1st-1

2nd-2

3rd-2

4th-2

5th-1

6th-2

7th-1

8th-1

Tenakee Springs

March 15 is the deadline for homeschool families to submit quarterly work samples.

Playground Improvement Update

Over Spring Break we plan to build and install a piece of playground equipment that was donated by the Campbell family. This is a set of towers with a slide. This is a used piece of equipment that was part of a former playground in Juneau. The Campbells also donated several super sacks full of rubber substrate to lay under our equipment. We also plan to dig up the concrete base of our existing swingset to add additional concrete for better stability.

Harmony Educational Services partnership

The Distance Education Program is seeking a partnership with Harmony Education Services as described during the last RSB Work Session. We are seeking this partnership to raise revenue to pay for the costs of educating students in Tenakee Springs.

Facilities

Our water froze in early March for less than a day. No permanent damage has been discovered.

Gustavus Advisory School Board

Regular Meeting
Monday, March 4th
5:30pm

CALL TO ORDER: 5:35 pm

ATTENDANCE:

- Board members: Stacey Proctor, Paul Dzubay, Molly Kelly, Deja Jarvis and Chantel Mulligan-Rear

PUBLIC ATTENDANCE:

- Principal of Gustavus School Karen Mcspadden

APPROVAL OF AGENDA:

- Chantel made a motion to approve the agenda, Molly seconded that motion.

APPROVAL OF MINUTES FROM LAST MEETING:

- Approved unanimously by all board members after review.

CORRESPONDENCE:

- None

PUBLIC COMMENT:

- None

REPORTS:

- Principals Report

Academic progress remains positive, athletes are consistently meeting grade requirements this year to participate in sports. Attendance rates have been good, some students struggle to catch up after long vacations, No major discipline actions have occurred at the school this year. Students continue to demonstrate respect and fairness to each other. There are some bullying concerns in the lower school, this is affecting a few students. Efforts are being made to address this issue effectively. Facilities and Maintenance, the septic issue has been ongoing, we are operating on one pump due to issues with a float switch, Mark, John and Jeff are working to find a sensible solution. Athletics just returned from Regionals, Bodin winning a sportsmanship award, Tucker winning all-conference.

(CONGRATS to you both) There will be no changes in staffing, one teacher is looking for housing close to 4-corners, please call Danielle at the school with any leads. All staff are returning next year. Graduation is scheduled for May 19th 2024. Open gym has been presenting challenges to maintain, rules and violations, improper storage of sports equipment. Consideration is being given to placing locks in the problem areas. Certain items are off limits. Jessie Soder received the approval for the Point hike, the Principal will attend this event. Foxes Den is closed, severance letters have been handed out to staff.

OLD BUSINESS:

- None

NEW BUSINESS:

- Graduation 2024
- Gustavus School Fund Request

BOARD MEMBER DISCUSSION:

- Gustavus School Fund Request from Jessie Soder for Point Hike food.
This was discussed by all board members. Chantel made a motion to approve, Molly seconded the motion and all board members unanimously approved this Gustavus School Funds request. We look forward to seeing photos and hearing all about it. ASB recommends the kids to come up with a small fundraiser to put back into the fund.
- CHATHAM SCHOOL DISTRICT CALENDAR 24'-25'
The ASB would like to see the 2024-2025 school calendar shared with parents, staff, students and ASB board members before the RSB adopts A, B or B. Only one ASB member was able to see the proposed calendar and stated it had the options listed as A, B or B. Can we send this out again? A lot of folks are not on Facebook, Email may be a better option to share with the public.

MEETING ADJOURNED:

- Adjourn 6:14pm
- Next Regular Meeting: April 2nd 5:30 pm



Karen McSpadden <kmcspadden@chatham.sd.org>

Gustavus School Lift Station

1 message

Mark Berry <bscgustavus@yahoo.com>
Reply-To: Mark Berry <bscgustavus@yahoo.com>
To: "rwatkins@chatham.sd.org" <rwatkins@chatham.sd.org>
Cc: Karen McSpadden <kmcspadden@chatham.sd.org>

Mon, Mar 11, 2024 at 8:29 AM

Hi Ralph;

As a followup to our phone conversation last Friday, I've put together what I feel is a solid alternative to trying to resuscitate the current sewer lift station at the school. Basically replacing both pumps (one is already dead) and replace the sophisticated custom built pump control panel which depends on the currently non-functioning level sensor (that requires a technician to program a new one in) with an off the shelf duplexing control panel that will automatically run the pumps as necessary via several redundant floats in the lift station. This would enable much easier field fixes as would not rely on expertise outside of Gustavus to repair the system. Also the individual components are more readily available.

I feel comfortable that you can treat this as quote to not exceed with the one caveat that as we have not yet talked with an engineer so that cost, and any related costs that ensue from any such engineering, are not included and would be added as necessary.

I feel comfortable that this repair pretty much follows suit with the existing system - same pump ratings and the panel has similar alarms (light and horn) so not sure additional engineering is required if treated as a repair.

I've attached spec sheets for the pumps and control panel I'd be using. The quote notes what is included, anything outside of that would need to be discussed prior to initiating the work. Pumps and panel would be approximately 2 weeks out from ordering.

Let me know if you or the board has any further questions - fee free to contact me anytime via email or call/text to my number below.

Mark

Berry's Specialty Contracting -- Sales & Service HVAC, Plumbing & Propane
P.O. Box 105 Gustavus,
AK 99826
Cell: 907.209.6737

4 attachments

Berry's Specialty Contracting

P.O Box 105
 Gustavus, AK 99826
 (907) 209-6737 cell

Lic # 24819

Quote

Date
03/10/24
Quote No.
623

Name/Address
Gustavus School P.O. Box 120 Gustavus, AK 99826

Project

Description	Quantity	Cost	Total
Gustavus School Main Sewer Lift Station Repair;			
Sewer Lift Station Materials	1	11,035.00	11,035.00
Materials Shipping to Site	1	750.00	750.00
Installation Job Labor & Electrical Work	1	14,575.00	14,575.00
-----Subtotal-----			26,360.00
Notes;			
<ul style="list-style-type: none"> - Clean out existing lift station and remove components. - Install new pumps and plumb to existing piping. - Install new float switches to operate pumps. - Install new high level alarm float. - Remove existing control panel and install new duplexing panel to automatically operate pumps via floats and display alarm if system fails. - Includes all mechanical and electrical work to install off the shelf duplexing control panel and pumps (see spec sheets attached). - Does NOT include engineering costs, nor additional or modified materials, travel and/or labor costs that may stem from additional engineering - to be added as required and/or necessary. 			
Thanks for the inquiry!		Total	\$26,360.00

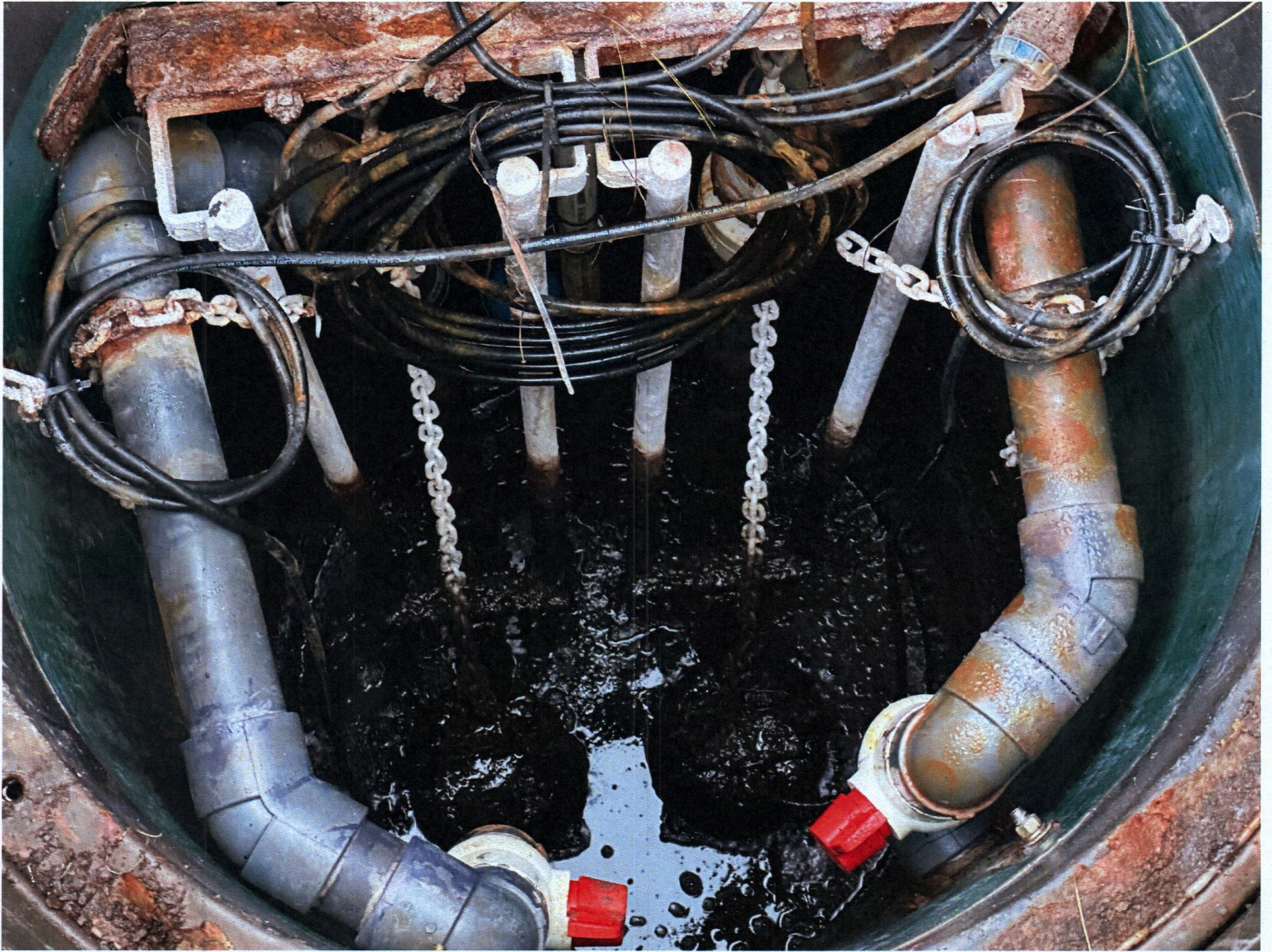

Dayton Grinder Pumps



PUMPS technical data sheet

Submersible Grinder pumps are designed to remove raw sewage wastewater from residential or commercial applications. Grinder pumps macerate solids contained in normal sewage or waste into fine slurry that can be pumped through small diameter piping to a sewage collection / treatment system for final processing. Grinder pumps can lift sewage to high elevations for pressure sewer applications.



11A342
2 HP, Stainless Steel
Submersible Grinder Pump

HP	2
Voltage	230V
Phase	Single
Frequency	60 Hz
Run Amps	11A
Start Amps	35A
RPM	3450
Motor Type	Cap Start / Cap Run Oil-filled with Class B insulation

Overload Protection	Internal Thermal Overload
Motor Shaft Material	410 Stainless Steel
Motor Housing Material	Cast Iron and 304 Stainless Steel
Motor Duty	Continuous
Motor End Bearing	Single Row Ball
Pump End Bearing	Single Row Ball
Lubrication	Oil Lubricated
Discharge	1-1/4 Inch FNPT, Flanged, Vertical
Volute Material	Cast Iron
Base Material	Cast Iron
Impeller Type	Open Vortex
Impeller Material	Ductile Iron
Hardware Material	Stainless Steel
Cutter and Ring	HRC 58 Chrome Steel
O-rings	Buna-N
Seal Type	Dual Mechanical
Seal Materials	Carbon Ceramic/ Buna-N Silicon Carbide/Silicon Carbide Buna-N
Operation	Manual
Power Cord	14/3 SJTW, 15' (4.6m), Stripped Leads
Max. Solids Handling	1/8" (0.32cm) spherical
Max. Water Temperature	104°F (40°C)
Designed Fluid Environment	Water / Sewage Wastewater

Outline Dimensions

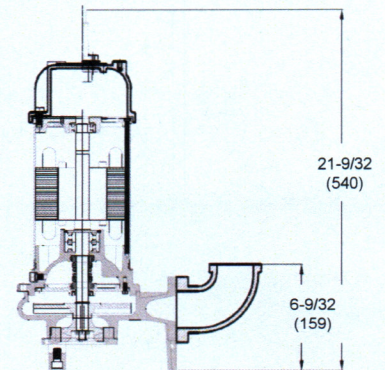
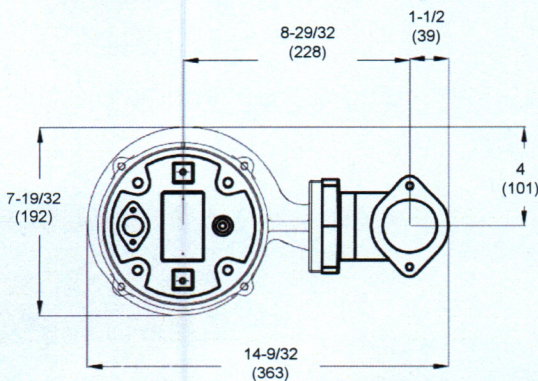

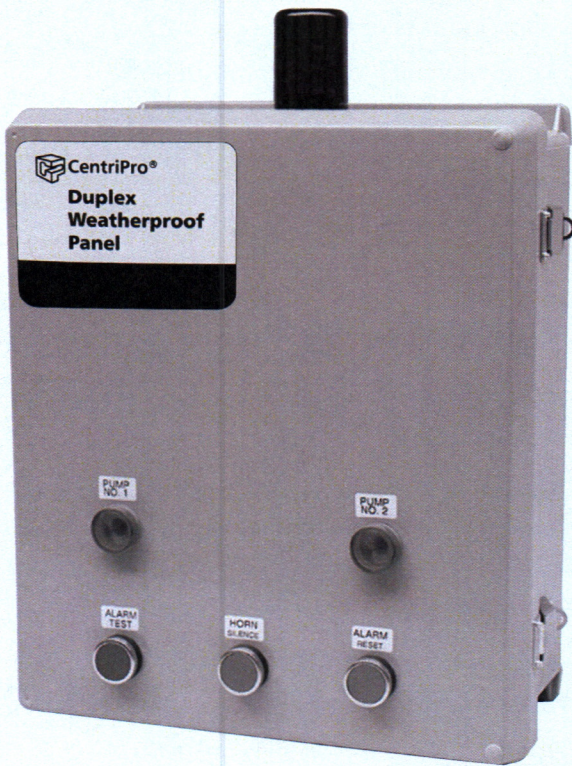

FEATURES

NEMA 4X, 30 watt, flashing red light and alarm horn - 95db.

NEMA 4X, fiberglass enclosure with gasketed, hinged door and stainless steel hardware.

Entire unit is UL and CUL listed.

Single Phase

Field adjustable for 115, 208 or 230V, 60 Hz.

2 pump circuit breakers.

Three Phase

Field adjustable for 208/230 /460/575V, 60 Hz.

115V control circuit transformer.

2 adjustable motor overload protectors.

Heaters not required.

Provides fully automatic operation for two pumps.

Solid state pump alternator circuit displays float status for ease of installation and trouble shooting.

DUPLEX NEMA 4X WEATHERPROOF PANELS

SINGLE AND THREE PHASE CONTROL PANELS

ADDITIONAL OPTIONS

Code (add as required)

- A = Guaranteed pump submergence circuit
- C = 115V condensation heater
- D = Single phase lightning arrestor
- E = Three phase lightning arrestor
- G = Elapsed time meter (2) - Duplex
- J = Seal fail circuit (2) - Duplex
- L = Cycle counter (2) - Duplex
- N = High temp. indicator with pump shutdown - Duplex

P = Special duplex Mini CAS seal fail and high temperature circuit for use on only three phase 15/20GD, 15/20GX, 1GA/2GA, GV Plus and Impact pumps. For single phase, see CentriPro single phase grinder control panels bulletin BCP1PGP for standard, BCP1PC1P for explosion proof.

T = 4 intrinsically safe relays in duplex panel

YY= Duplex dry contact for seal failure interface to building management system.

ZZ= Duplex dry contact for pump running interface to building management system.

When ordering options, add the appropriate code number as a suffix to the panel order number.

Example...D31625CG adds a condensation heater and (2) elapsed time meters.

ENCLOSURE DIMENSIONS (in inches)

Single Phase						
A	B	C	D	E	F	G
10.1	15.5	18.3	14.8	6.8	7.2	13.3
Three Phase						
A	B	C	D	E	F	G
12.1	17.5	20.3	16.8	6.8	7.2	15.3
NOTE: Mounting holes are 3/8".						

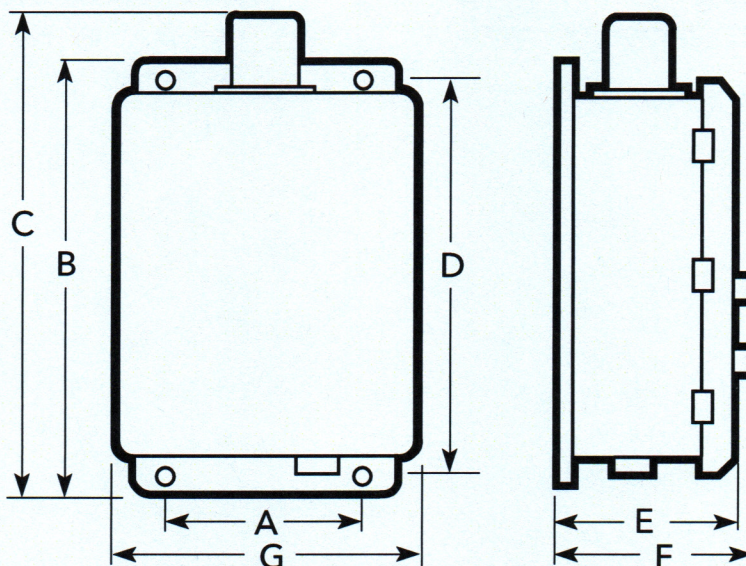

DUPLEX SINGLE PHASE WIRING DIAGRAM - D10020

NOTE: The standard panels shown in this book are not designed to be used with pumps requiring external capacitors. See the catalog for panels with built-in capacitor packs.

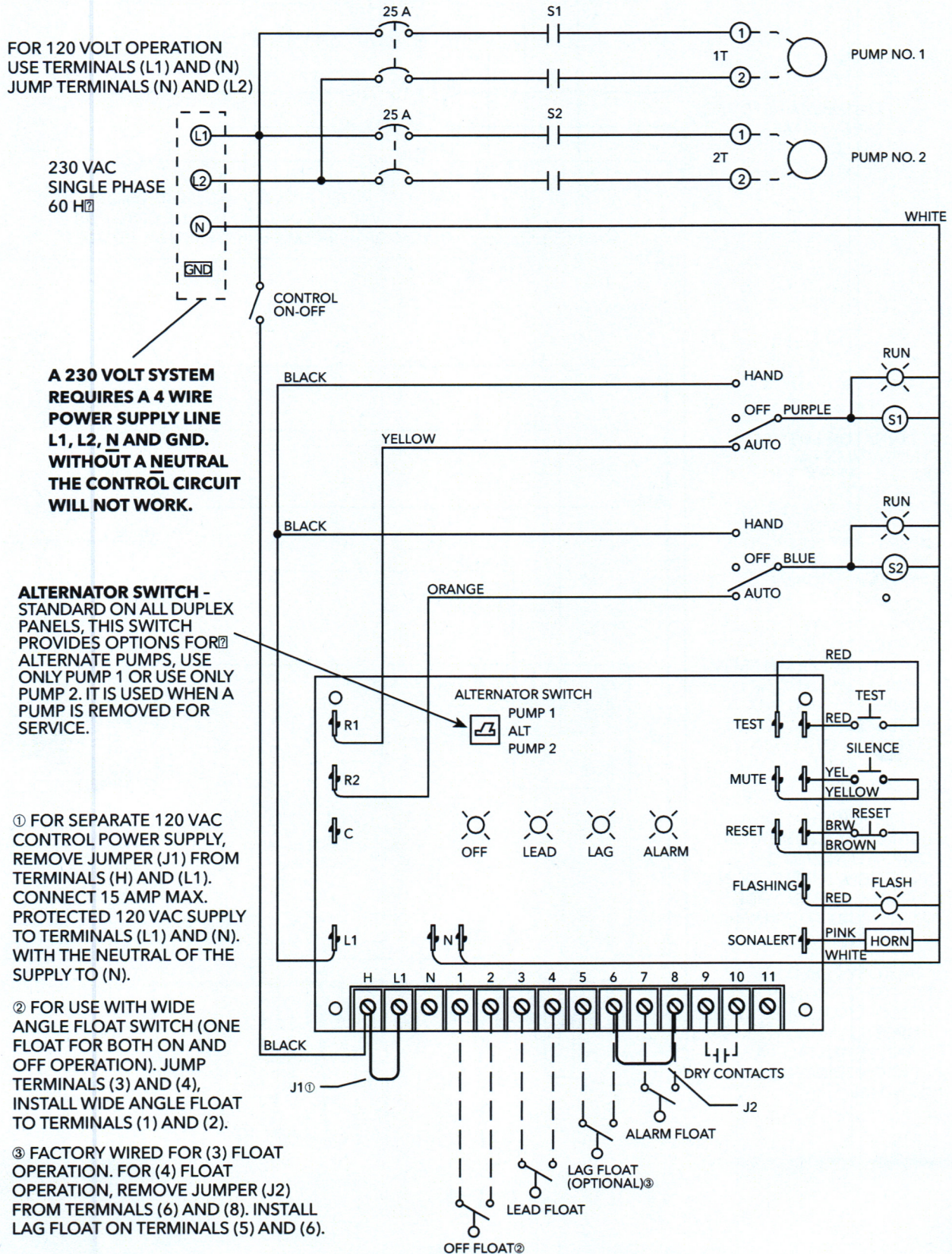

NOTES

CHANGE PROPOSAL



Johnson Controls Inc
 4000 W. Dimond Blvd
 Anchorage Ak, 99502
 907-561-1911

JCI Project Number	650216709		
PROJECT NAME	Tenakee FA		
LOCATION OF WORK	118 Tenakee Ave Tenakee Springs, Ak 99841		
CONTRACT NO.	10605	CHANGE PROPOSAL NO.	CO1
REQUESTING PARTY		DATE OF REQUEST	3.6.24
PROJECT MANAGER	Benjamin Sparkman	CONTRACTOR	
OWNER		ENGINEER	

CHANGE PROPOSAL OVERVIEW

DESCRIPTION OF CHANGES	Local voice dialer will be added this was approved by the fire marshal. Per code we will also be adding a pull station to one of the exits upstairs due to the building not being sprinkled. Code requires a pull station per exit in this situation.
REASON FOR CHANGE	Code requires monitoring of the FA system, and a pull station at each exit if the building is not sprinkledS. Fire Marshal approved a local voice dialer.
SUPPORT & JUSTIFICATION DOCUMENTS	NFPA-72
SPECIFICATIONS	

CHANGE IN CONTRACT PRICE

ORIGINAL PRICE	\$46,628.32
NET CHANGES OF PREVIOUS CHANGE ORDERS	
NET INCREASE / DECREASE	\$7,914.61
TOTAL CONTRACT PRICE WITH APPROVED CHANGES	\$54,542.93

CHANGE IN CONTRACT TIMES

ORIGINAL TIME IN DAYS	
NET CHANGES OF PREVIOUS CHANGE ORDERS IN DAYS	
NET INCREASE / DECREASE IN DAYS	1
TOTAL CONTRACT TIME WITH APPROVED CHANGES	1

RECOMMENDED BY:		ACCEPTED BY:	
DATE:		DATE:	
REVIEWED BY:		APPROVED BY:	
DATE		DATE	

It is hereby agreed the changes and additions in the Scope of Work noted below shall constitute an Extra to the contract in the amount noted on this form. The sum shall be added to the original value of the above numbered contract and at Extras heretofore approved. This quotation is valid for 30 days.

PROJECT NAME	Tenakee FA		
LOCATION OF WORK	118 Tenakee Ave Tenakee Springs, Ak 99841		
CONTRACT NO.	10605	CHANGE PROPOSAL NO.	CO1
		DESCRIPTION	SELL
GENERAL CONDITIONS			\$0.00
MATERIAL (INCLUDES SUNDRy)			\$1,072.37
LABOR			\$2,535.83
DESIGN			\$396.41
SUBCONTRACTING			\$3,910.00
EQUIPMENT/RENTALS			\$0.00
FINANCIAL- SPECIAL CONDITIONS			\$0.00
		TOTAL	\$7,914.61
CONTRACTOR SIGNATURE		PROJECT MANAGER SIGNATURE	<i>Benjamin Sparkman</i>
DATE		DATE	3.6.24

CHANGE PROPOSAL



Johnson Controls Inc
 4000 W. Dimond Blvd
 Anchorage Ak, 99502
 907-561-1911

JCI Project Number	650210375		
PROJECT NAME	Gustavus School Gym		
LOCATION OF WORK	12 Gustavus RD Gustavus AK		
CONTRACT NO.	10605	CHANGE PROPOSAL NO.	CO3
REQUESTING PARTY		DATE OF REQUEST	
PROJECT MANAGER	Benjamin Sparkman	CONTRACTOR	
OWNER		ENGINEER	

CHANGE PROPOSAL OVERVIEW	
DESCRIPTION OF CHANGES	New Audio system required by the AHJ. Price is based on Change Order being approved within 30 days
REASON FOR CHANGE	Additional material called out by the AHJ/Code requirement
SUPPORT & JUSTIFICATION DOCUMENTS	NFPA-72
SPECIFICATIONS	

CHANGE IN CONTRACT PRICE		CHANGE IN CONTRACT TIMES	
ORIGINAL PRICE	\$21,032.32	ORIGINAL TIME IN DAYS	
NET CHANGES OF PREVIOUS CHANGE ORDERS	-\$1,060.58	NET CHANGES OF PREVIOUS CHANGE ORDERS IN DAYS	
NET INCREASE / DECREASE	\$49,849.12	NET INCREASE / DECREASE IN DAYS	2
TOTAL CONTRACT PRICE WITH APPROVED CHANGES	\$69,820.86	TOTAL CONTRACT TIME WITH APPROVED CHANGES	2

RECOMMENDED BY:		ACCEPTED BY:	
DATE:		DATE:	
REVIEWED BY:		APPROVED BY:	
DATE		DATE	

It is hereby agreed the changes and additions in the Scope of Work noted below shall constitute an Extra to the contract in the amount noted on this form. The sum shall be added to the original value of the above numbered contract and at Extras heretofore approved. This quotation is valid for 30 days.

Page 2 EXTENDED COST DETAIL - 10605CO3

PROJECT NAME	Gustavus School Gym		
LOCATION OF WORK	12 Gustavus RD Gustavus AK		
CONTRACT NO.	10605	CHANGE PROPOSAL NO.	CO3
		DESCRIPTION	SELL
GENERAL CONDITIONS			\$0.00
MATERIAL (INCLUDES SUNDRY)			\$18,298.58
LABOR			\$7,768.28
DESIGN			\$5,393.77
SUBCONTRACTING			\$18,388.50
EQUIPMENT/RENTALS			\$0.00
FINANCIAL- SPECIAL CONDITIONS			\$0.00
		TOTAL	\$49,849.12
CONTRACTOR SIGNATURE		PROJECT MANAGER SIGNATURE	
DATE		DATE	

MATERIAL					
MATERIAL NAME	DESCRIPTION/PN	QTY	SELL/EA	SELL/EXT	
WP BB SPKR/VIS WALL RED	49WPBB-SVWR	1	\$43.91	\$43.91	
WP SV COVER WALL RED FIRE	49SVC-WRFIRE-O	1	\$33.35	\$33.35	
SPKR/VISIBLE APPL ONLY WALL WP	49SV-APPLW-O	1	\$290.12	\$290.12	
ADD SPKER/STRB, WG, WALL, RED	49WG-SVWCR	5	\$156.25	\$781.23	
SPKER/STRB MOUNTING PLATE RED	49MP-SVWR	5	\$21.46	\$107.28	
SV COVER WALL RED FIRE	49SVC-WRFIRE	5	\$13.61	\$68.07	
HIFI SPKR/VIS APPL ONLY WALL	49HFV-APPLW	5	\$190.09	\$950.44	
STROBE WHIE CEILING COVER FIRE	49VOC-CWF	2	\$11.16	\$22.32	
ADDRESS STROBE CEILING MT	49VO-APPLC	2	\$152.51	\$305.02	
VO Wall Red FIRE	49VO-WRF	1	\$122.09	\$122.09	
2 BAY BB/GDOOR/DRESS PNL RED	2975-9442	1	\$1,506.19	\$1,506.19	
ES PS FIRE ALARM PANEL	4100-9701	1	\$10,882.72	\$10,882.72	
CONN SERV GATEWAY IP COMM	4100-2504	1	\$561.54	\$561.54	
33AH BATTERIES	2081-9276	2	\$152.91	\$305.82	
WIRE GUARD, WALL RED	4905-9961	1	\$151.04	\$151.04	
IND ADDESSABLE MODULE	4090-9001	2	\$37.65	\$75.30	
IAM MOUNTING BRACKET	4090-9810	2	\$19.82	\$39.65	
RELAY IAM	4090-9002	1	\$57.89	\$57.89	
SENSOR BASE	4098-9792	2	\$42.93	\$85.86	
PHOTO SENSOR	4098-9714	2	\$41.42	\$82.84	
COVER ADDRESS MODULE	4090-9807	2	\$24.04	\$48.07	
TRIM PLATE SURFACE MOUNTING	4090-9802	1	\$33.70	\$33.70	
SURGE PROTECTIVE DEVICE	E120V-GT	1	\$80.61	\$80.61	
EXPEDITED SHIPPING/FREIGHT CHARG		0			
SUNDRY (SHIPPING, TRANSPORTATION, USE-TAX)				\$1,663.51	
LABOR		QTY	EXTENDED PRICE		
COMM / TECH		15		\$4,010.53	
INSTALLATION		0			
PROJ MGMT		11		\$2,759.65	
PV/ASSOCIATE PM		0			
SPECIFIC PROD TRAINING		0			
PREP/FAB		0		\$998.10	
DESIGN		QTY	EXTENDED PRICE		
Design		14		\$3,255.88	
CAD		12.5		\$2,137.88	
Third party designer		0			
SUB- PE Stamp		0			
Filing Fees		0			
Consumables		0			
Outside printing service		0			
As-builts / Manuals non-labor costs		0			
CONTRACTOR SIGNATURE		PROJECT MANAGER SIGNATURE			
DATE		DATE			

CHANGE PROPOSAL



Johnson Controls Inc
4000 W. Dimond Blvd
Anchorage Ak, 99502
907-561-1911

JCI Project Number	650210265		
PROJECT NAME	Angoon Elementary School FA Upgrade		
LOCATION OF WORK	407 Katanook Rd Angoon, AK 99820		
CONTRACT NO.	10605	CHANGE PROPOSAL NO.	CO2
REQUESTING PARTY		DATE OF REQUEST	1/11/24
PROJECT MANAGER	Benjamin Sparkman	CONTRACTOR	
OWNER		ENGINEER	

CHANGE PROPOSAL OVERVIEW

DESCRIPTION OF CHANGES	New Audio system required by AHJ. Prices are based on getting changed order signed by end of January.
REASON FOR CHANGE	Additional material called out by the AHJ
SUPPORT & JUSTIFICATION DOCUMENTS	NFPA-72
SPECIFICATIONS	

CHANGE IN CONTRACT PRICE

ORIGINAL PRICE	\$45,706.84
NET CHANGES OF PREVIOUS CHANGE ORDERS	-\$14,460.50
NET INCREASE / DECREASE	\$47,689.15
TOTAL CONTRACT PRICE WITH APPROVED CHANGES	\$78,935.49

CHANGE IN CONTRACT TIMES

ORIGINAL TIME IN DAYS	
NET CHANGES OF PREVIOUS CHANGE ORDERS IN DAYS	
NET INCREASE / DECREASE IN DAYS	31
TOTAL CONTRACT TIME WITH APPROVED CHANGES	31

RECOMMENDED BY:		ACCEPTED BY:	
DATE:		DATE:	
REVIEWED BY:		APPROVED BY:	
DATE		DATE	

It is hereby agreed the changes and additions in the Scope of Work noted below shall constitute an Extra to the contract in the amount noted on this form. The sum shall be added to the original value of the above numbered contract and at Extras heretofore approved. This quotation is valid for 30 days.

Page 2 EXTENDED COST DETAIL - 10605CO2

PROJECT NAME	Angoon Elementary School FA Upgrade		
LOCATION OF WORK	407 Katanook Rd Angoon, AK 99820		
CONTRACT NO.	10605	CHANGE PROPOSAL NO.	CO2
		DESCRIPTION	SELL
GENERAL CONDITIONS			\$0.00
MATERIAL (INCLUDES SUNDRY)			\$17,951.63
LABOR			\$6,597.43
DESIGN			\$4,268.59
SUBCONTRACTING			\$18,871.50
EQUIPMENT/RENTALS			\$0.00
FINANCIAL- SPECIAL CONDITIONS			\$0.00
		TOTAL	\$47,689.15
CONTRACTOR SIGNATURE		PROJECT MANAGER SIGNATURE	<i>Benjamin Sparkman</i>
DATE		DATE	1.22.24



Project Number	Project Name	
650210265	Angoon Elementary School	
PID		DESCRIPTION
	Required	
Items included in original proposal		
4098-9714	32	PHOTO SENSOR
4098-9792	35	SENSOR BASE
4098-9755	1	DUCT SENSOR HOUSING
2098-9806	1	REMOTE TEST STATION
4090-9001	3	SUPERVISED IAM
4090-9807	3	COVER-ADDRESS MODULE SURFACE
4090-9810	3	BRACKET, IAM
4099-9004	3	MANUAL STATION - SINGLE ACTION-LED
E120V-GT	1	SPACEAGE 120V HYBRID SURGE PROTECTIVE DEVICE
4081-9004	3	EOL 6.8K 1/2W
4090-9002	1	RELAY IAM
4090-9802	1	COVER-ADDRESS MODULE SURFACE
49VO-APPLW	5	VO APPLIANCE ONLY WALL
49VOC-WWFIRE	5	VO COVER WALL WHITE FIRE
4098-9734	3	TRUEALARM HIGH TEMP HEAT SENSOR
4098-9857	1	SAMPLING TUBE 73", PLASTIC
Below items required by AHJ		
4100-2504	1	CONNECTED SERVICES GATEWAY W/IP COMM
4100-9701	1	ES PS Master Controller - English
2081-9276	2	33 AH Batteries
2975-9442	1	2 BAY BB/GDOOR/DRESS PNL RED
49HFV-APPLW	12	HIFI SPKR/VIS APPL ONLY WALL
49SVC-WWFIRE	12	SV COVER WALL WHITE FIRE
49MP-SVWW	12	SV MOUNTING PLATE WALL WHITE
49SV-APPLW-O	1	SPKR/VISIBLE APPL ONLY WALL WP
49SVC-WRFIRE-O	1	WEATHERPROOF SV COVER WALL RED FIRE
49WPBB-SVWR	1	WEATHERPF BB SPKR/VIS WALL RED

CHANGE PROPOSAL



Johnson Controls Inc
4000 W. Dimond Blvd
Anchorage Ak, 99502
907-561-1911

JCI Project Number	650209582		
PROJECT NAME	Klukwan School		
LOCATION OF WORK	Chatham School District Haines HWY		
CONTRACT NO.	10605	CHANGE PROPOSAL NO.	CO2
REQUESTING PARTY		DATE OF REQUEST	
PROJECT MANAGER	Benjamin Sparkman	CONTRACTOR	
OWNER		ENGINEER	

CHANGE PROPOSAL OVERVIEW

DESCRIPTION OF CHANGES	NEW Audio system required by AHJ. Prices are based on change order approval within 30 days of receipt
REASON FOR CHANGE	Additional Material called out by the AHJ
SUPPORT & JUSTIFICATION DOCUMENTS	NFPA-72
SPECIFICATIONS	

CHANGE IN CONTRACT PRICE

ORIGINAL PRICE	\$71,116.79
NET CHANGES OF PREVIOUS CHANGE ORDERS	-\$26,075.79
NET INCREASE / DECREASE	\$81,427.04
TOTAL CONTRACT PRICE WITH APPROVED CHANGES	\$126,468.04

CHANGE IN CONTRACT TIMES

ORIGINAL TIME IN DAYS	
NET CHANGES OF PREVIOUS CHANGE ORDERS IN DAYS	
NET INCREASE / DECREASE IN DAYS	1
TOTAL CONTRACT TIME WITH APPROVED CHANGES	1

RECOMMENDED BY:		ACCEPTED BY:	
DATE:		DATE:	
REVIEWED BY:		APPROVED BY:	
DATE		DATE	

It is hereby agreed the changes and additions in the Scope of Work noted below shall constitute an Extra to the contract in the amount noted on this form. The sum shall be added to the original value of the above numbered contract and at Extras heretofore approved. This quotation is valid for 30 days.

Page 2 EXTENDED COST DETAIL - 10605CO2

PROJECT NAME		Klukwan School	
LOCATION OF WORK		Chatham School District Haines HWY	
CONTRACT NO.	10605	CHANGE PROPOSAL NO.	CO2
		DESCRIPTION	SELL
GENERAL CONDITIONS			\$0.00
MATERIAL (INCLUDES SUNDRY)			\$26,011.20
LABOR			\$6,033.53
DESIGN			\$7,096.81
SUBCONTRACTING			\$42,285.50
EQUIPMENT/RENTALS			\$0.00
FINANCIAL- SPECIAL CONDITIONS			\$0.00
		TOTAL	\$81,427.04
CONTRACTOR SIGNATURE		PROJECT MANAGER SIGNATURE	<i>Benjamin Sparkman</i>
DATE		DATE	2.27.24

PAGE 3 DETAIL PRINTOUT - 10605CO2

MATERIAL				
MATERIAL NAME	DESCRIPTION/PN	QTY	SELL/EA	SELL/EXT
MASTER CONTROLLER PANEL	4100-9701	1	\$10,882.72	\$10,882.72
2 BAY BACK BOX GLASS DOOR RED	2975-9442	1	\$1,506.19	\$1,506.19
50AH BATTERIES	2081-9296	2	\$237.46	\$474.91
HF SPEAKER/STRB CEILING	49HFV-APPLC	7	\$225.79	\$1,580.53
APPLIANCE COVER WHITE LETTER	49SVC-CWFIRE	7	\$13.77	\$96.40
HF SPEAKER/STRB WALL	49HFV-APPLW	19	\$190.09	\$3,611.67
APPLIANCE COVER WHITE LETTER	49SVC-WWFIRE	19	\$14.07	\$267.33
WP SPEAKER STRB WALL MOUNT	49SV-APPLW-O	3	\$290.12	\$870.37
APPLIANCE COVER RED LETTER	49SVC-WRFIRE-O	3	\$33.35	\$100.05
WP BACKBOX WALL MOUNT RED	49WPBB-SVWR	3	\$43.91	\$131.74
MANUAL PULL STATION	4099-9004	3	\$83.46	\$250.37
IDNET RELAY IAM ADDRESSABLE	4090-9002	2	\$57.89	\$115.79
DUCT SMOKE DETECTOR	4098-9755	3	\$220.40	\$661.21
STANDARD BASE	4098-9792	4	\$42.93	\$171.72
HEAT SENSOR	4098-9733	2	\$31.02	\$62.04
SMOKE SENSOR	4098-9714	2	\$41.42	\$82.84
WIRE GUARD RED	49WG-SVWCR	7	\$156.25	\$1,093.72
PULL STATION COVERS	STI1100	3	\$95.91	\$287.74
MOUNTING PLATE WHITE	49MP-SVWW	19	\$20.53	\$390.00
TRIM PLATE SURFACE MNT	4090-9802	2	\$33.70	\$67.40
lcd ANNUNCIATOR	4603-9101	1	\$729.82	\$729.82
120 V SURGE PROTECTOR	E120V-GT	1	\$80.61	\$80.61
REMOTE TEST STATION	2098-9806	3	\$43.79	\$131.37
EXPEDITED SHIPPING/FREIGHT CHARG		0		
SUNDRY (SHIPPING, TRANSPORTATION, USE-TAX)				\$2,364.65
LABOR		QTY	EXTENDED PRICE	
COMM / TECH		6		\$1,604.21
INSTALLATION		0		
PROJ MGMT		12		\$3,010.53
PV/ASSOCIATE PM		0		
SPECIFIC PROD TRAINING		0		
PREP/FAB		0		\$1,418.79
DESIGN		QTY	EXTENDED PRICE	
Design		25		\$5,814.08
CAD		7.5		\$1,282.73
Third party designer		0		
SUB- PE Stamp		0		
Filing Fees		0		
Consumables		0		
Outside printing service		0		
As-builts / Manuals non-labor costs		0		
CONTRACTOR SIGNATURE		PROJECT MANAGER SIGNATURE		
DATE		DATE		

Lice Policy AR

In keeping with recommendations from the above-cited medical associations, children with nits may remain in school. Children with live lice will be sent home to be treated and may return to school after treatment. Upon their return, students will be checked by the nurse. The district also focuses efforts on educating families about head lice. Follows is the district policy:

“School personnel shall actively pursue the prevention and control of head lice in the District’s schools by developing a consistent education, screening and follow-up program for all students. Principals and school personnel trained to identify live lice shall adhere to the following guidelines:

1. When students are observed/reported to have live head lice any time during the school year:
 - a. Playmates closely associated with the student and possibly siblings of the student that attend the same school may be checked for live lice, which are defined by the Centers for Disease Control and Prevention as crawling lice. In general, school-wide checks are not necessary.
 - b. Parents of each student identified as having live lice will be contacted by a school/District representative advising them of the finding. Parents will be asked to pick up the child for treatment.
2. Principals or school/District personnel shall offer parents of students identified as having live lice:
 - a. Visual evidence of live lice in the student’s hair.
 - b. Verbal and/or written information/direction for hair treatment and household procedures.
3. In most cases, students should not be excluded from school. However, in all instances when personnel identify live lice, they shall confirm with the student and/or parent/guardian that the following have occurred:
 - a. The parent/guardian has combed the student’s hair with an actual lice/nit comb or applied special lice killing shampoo on the same or next day.
 - b. When the student returned to school after treatment, designated school personnel rechecked the student before s/he returned to the classroom. If live lice remained, steps 2 and 3 above were re-established.
4. School personnel shall follow up with students found with a second and subsequent cases of live head lice to assure that:
 - a. Prescribed medical treatment for live lice has been applied to the student’s hair no later than the next day.
 - b. Any second application required is applied within the recommended time frame.
5. The Superintendent/designee shall:
 - a. Establish education/information programs on head lice control methods for school personnel, community members, students and parents.
 - b. Provide each school with written materials on head lice control and prevention.”

**TITLE: FIRST READING OF NEW BOARD POLICY AND DELETION OF
ADMINISTRATIVE REGULATION 5141.33 - HEAD LICE**

March 16, 2021 Page 1 of 1

Student Support Services Information # 1

Prepared by: Sean Goldman, Assistant Superintendent Student Support Services

Background Information

Board Policy and Administrative Regulation 6159 is being updated to reflect new State regulations and to conform with current medical practices nationwide. The head louse, or *Pediculus Humanus capitis*, is a parasitic insect that can be found on the head, eyebrows, and eyelashes of people. Head lice feed on human blood several times a day and live close to the human scalp. Head lice are not known to spread disease.

Students diagnosed with live head lice do not need to be sent home early from school; they can go home at the end of the day, be treated, and return to class after appropriate treatment has begun. Nits may persist after treatment, but successful treatment should kill crawling lice.

Head lice can be a nuisance but they have not been shown to spread disease. Personal hygiene or cleanliness in the home or school has nothing to do with getting head lice.

The Centers for Disease Control (CDC), the American Academy of Pediatrics (AAP) and the National Association of School Nurses (NASN) advocate that “no-nit” policies should be discontinued. “No-nit” policies that require a child to be free of nits before they can return to schools should be discontinued for the following reasons:

1. Many nits are more than ¼ inch from the scalp. Such nits are usually not viable and very unlikely to hatch to become crawling lice, or may in fact be empty shells, also known as ‘casings’.
2. Nits are cemented to hair shafts and are very unlikely to be transferred successfully to other people.
3. The burden of unnecessary absenteeism to the students, families and communities far outweighs the risks associated with head lice.
4. Misdiagnosis of nits is very common during nit checks conducted by nonmedical personnel.

The changes/deletions are indicated in ~~striketrough~~. New policy is highlighted and aligns with current Simi Valley Unified School District procedures. New policy suggested by staff rather than CSBA is indicated in all CAPITAL letters and highlighted.

Fiscal Analysis

No fiscal impact

Recommendation

This item is brought forward for information only.

Policy 5141.33: Head Lice

CSBA NOTE: The following optional policy is consistent with the Guidelines on Head Lice Prevention and Control for School Districts and Child Care Facilities issued by the California Department of Public Health (CDPH) in March 2012. CDPH guidelines and a position statement by the California School Nurses Organization note that, although lice are a nuisance, they are not associated with the spread of disease and are not highly transferable in the school setting. The Governing Board recognizes that head lice infestations among students require treatment but do not pose a risk of transmitting disease. The Superintendent or designee shall encourage early detection and treatment in a manner that minimizes disruption to the educational program and reduces student absences.

CSBA NOTE: The following optional paragraph provides for distribution of educational information to parents/guardians of preschool and elementary students based on a finding reported in the CDPH guidelines that children ages 3-11 years are at highest risk for head lice infestation. High school districts that choose to routinely provide information to parents/guardians should revise the following paragraph to reflect applicable grade levels.

The CDPH publishes a brochure for parents/guardians, A Parent's Guide to Head Lice, which is available on the CDPH web site. As discussed in the brochure, the recommended treatment for head lice involves nit combing and use of an over-the-counter head lice shampoo. Prescription treatments are also available. The CDPH publishes a brochure for parents/guardians, A Parent's Guide to Head Lice, which is available on the CDPH web site. As discussed in the brochure, the recommended treatment for head lice involves nit combing and use of an over-the-counter head lice shampoo. Prescription treatments are also available.

The Superintendent or designee may distribute information to parents/guardians of preschool and elementary students regarding routine screening, symptoms, accurate diagnosis, and proper treatment of head lice infestations. The Superintendent or designee also may provide related information to school staff.

School employees shall report all suspected cases of head lice to the school nurse or designee as soon as possible.

CSBA NOTE: The CDPH, Centers for Disease Control and Prevention, American Academy of Pediatrics, and California School Nurses Organization all oppose "no-nit" policies (i.e., policies that require students to be free of nits before returning to school), citing common misdiagnosis by nonmedical personnel, lack of evidence that such policies prevent or shorten outbreaks, and their belief that the benefits of school attendance outweigh the risks of head lice.

If a student is found with active, adult head lice, he/she shall be allowed to stay in school until the end of the school day. The parent/guardian of any such student shall be given information about the treatment of head lice and encouraged to begin treatment of the student immediately and to check all members of the family. The parent/guardian also shall be informed that the student shall be checked upon return to school the next day and allowed to remain in school if no active head lice are detected.

Upon the student's return to school, the school nurse or designee shall check the student for active head lice. If it is determined that the student remains infected with head lice, the school

nurse or designee shall contact the student's parent/guardian to discuss treatment. As needed, he/she may provide additional resources and/or referral to the local health department, health care providers, or other agencies.

CSBA NOTE: The following optional paragraph may be revised to reflect district practice. CDPH guidelines recommend that, because continuing infestations may signify other family or socioeconomic problems, a student with a chronic case of head lice (i.e., a student found infested during three separate months during a school year or for six consecutive weeks) should be reported to the school attendance review board and addressed by a multidisciplinary team which may consist of the school nurse, representatives of the local health department and social services, and other appropriate individuals.

If a student is found consistently infested with head lice, he/she may be referred to a

which may consist of the school nurse, representatives from the local health department and social services, and other appropriate individuals, to determine the best approach for identifying and resolving problems contributing to the student's head lice infestations.

CSBA NOTE: The following optional paragraph should be revised to reflect district practice. CDPH guidelines state that, although classroom or schoolwide notification is not recommended after student(s) have been detected with head lice, such notification is at the discretion of the school nurse or school administration.

When it is determined that one or more students in a class or school are infested with head lice, the principal or designee may, at his/her discretion, notify parents/guardians of students in that class or school and provide them with information about the detection and treatment of head lice.

Staff shall maintain the privacy of students identified as having head lice.

When a student is found to have head lice or nits in his/her hair, that student will be excluded from school. A letter of exclusion shall be given to the parent/guardian of the student at the time the student is excluded. This exclusion letter shall explain treatment procedures explaining how to rid the child of head lice and their nits. (Education Code 48213)

The excluded student shall be checked once upon his/her return to school by the school office staff or site principal. If the student is found to be free of lice and nits, he/she shall return to class. If the student is not free of lice and nits, the parent/guardian will be contacted and informed that the student may not return to

1. The principal and/or office personnel may, according to the judgment of the principal, examine the hair of

school until they are rechecked and found to be free of lice and nits. The student may return to school as soon as he/she is found to be free of lice and nits.

2. If there have been recurrent cases of head lice among several students in the student's classroom, the

When a student has been identified with head lice:

3. In any class in which a student is identified as having head lice, a parent/guardian notification letter shall that student's siblings.

school nurse may be called to check that classroom.

be sent home to classmates' parents/guardians.

Excluded students may return to school when they bring a note from the parent/guardian indicating the treatment used and when reexamination by the nurse or designee shows that all pests and nits have been removed.

Indicator 1 - GEPA

Chatham School District Equity for Students, Teachers, and other Program Beneficiaries

Description of Compliance

The Chatham School District provides equitable access and encourages participation in all programs. All programs are directed toward K-12 general education. Federal Law, State Law, and School District adopted policies ensure equal access and encourage participation for males and females alike, students of all races, students of all national origins, students of all colors, students with and without disabilities, and students meeting the minimum age requirement as established by state law.

The Chatham District's average school size of 48 students, K-12, dictates standardization of curriculum and program offerings for all students in a multi-graded classroom environment. This structure of the District's K-12 program revolves around a required curriculum that includes all students in the comprehensive program, which by its nature ensures equitable access and participation.

As an example, because of small number of students in 9-12 grade at the individual schools, the Chatham District has establishing coed teams as the standard most sports programs where there is an insufficient number of students of the same gender, thereby increasing participation of both boys and girl in traditional and non-traditional gender-oriented sports activities.

The Chatham District does not anticipate any new or additional initiative, beyond its current efforts, will be required to ensure equal access and encourage participation for males and females alike, students of all races, students of all national origins, students of all colors, students with and without disabilities.