

**AGENDA
OURAY CITY COUNCIL**

Monday, March 20, 2023 - 2:00 PM

**Ouray Community Center
320 6th Ave
Ouray, CO 81427**

VIRTUAL OPTION - <https://zoom.us/j/9349389230>

Meeting ID: 934 938 9230 Passcode: 491878 Or dial: 408 638 0968 or 669 900 6833

Ouray City Council Work Session

- Changes to this agenda can be found on the bulletin board at City Hall
- Electronic copies of the Council Packet are available on the City website at www.cityofouray.com. A hard copy of the Packet is also available at the Administrative Office for interested citizens.
- Notice is hereby given that a majority or quorum of the Planning Commission, Community Economic Development Committee, Beautification Committee, Tourism Advisory Committee, and/or Parks and Recreation Committee may be present at the above noticed City Council meeting to discuss any or all of the matters on the agenda below for Council consideration

1. 2:00pm - Tour of Ouray Hot Springs Pool
1220 Main Street, Ouray, CO
2. 3:00pm - Work Session
Ouray Community Center
320 6th Ave, Ouray CO
 - a. CALL TO ORDER
 - b. DISCUSSION ITEMS
 - a. Geothermal/heat Issues at the Hot Springs Pool
 - b. Alcohol at the Hot Springs Pool

City of Ouray – OX2 and OX6 Hot Springs Wells

1



WWE

Wright Water Engineers, Inc.
November 2022

History of OX2 and OX6 Wells

• Construction

- Constructed 34 years ago in 1988.
- Wells completed in a fractured bedrock formation with loose sands and boulders.
- Recent video survey indicates a potential for void spaces, loose sands, and open cavities.
- Historical construction reports indicate both wells encountered a sandy layer during drilling that stopped advancement of the well drilling due to excessive caving.
- Drilling with mud rotary and lost circulation during drilling.

OX2 Well Construction Report

DATE COMPLETED January 24, 1988

WELL LOG

From	To	Type and Color of Material	Water Loc.
0	2	Fill	
2	12	Sand, Gravel, and clays	3'
12	20	Clays	
20	60	Boulders, Sand, and Gravel	33'
60	95	Coarse, medium, and fine sands	87'

HOLE DIAMETER

15.25 in. from 0 to 23 ft.

12.25 in. from 23 to 43 ft.

6.75 in. from 43 to 95 ft.

DRILLING METHOD Rotary - Mud

CASING RECORD: Plain Casing

Size 14" & kind Steel from 0 to 23 ft.

Size 8 5/8 & kind Steel from 0 to 43 ft.

Size _____ & kind _____ from _____ to _____ ft.

Perforated Casing - NONE

Size _____ & kind _____ from _____ to _____ ft.

Size _____ & kind _____ from _____ to _____ ft.

Size _____ & kind _____ from _____ to _____ ft.

Historical Trends in OX2 Temperature and Production

- Temperature and water production from OX-2 are trending downward since 2020.
- Hot Springs Pool is having difficulty maintaining pool temperatures.
- Closed Wellhead Pressure
 - Historical Range (2013 to 2015): 3.5 to 9.5 psi
 - 2016: 7 psi
 - 2017: 7 psi
 - 2018: 6 psi
 - 2019: 5.5 psi
 - 2022: 3.5 psi



Approaches to Address the Issue



- **Rehabilitate or Replace OX2 to Increase Production.**
- **Proposal from Layne – Rehabilitate OX2**
 - Received a proposal and estimate from Layne to rehabilitate OX2 well.
 - Layne is proposing to advance an 8-inch mud rotary boring to a depth of 150 feet.
 - Estimated construction cost – approximately \$315,000.
- **WWE Concerns with Layne’s Current Proposal**
 - Potential for Layne to lose circulation during drilling. Historical reports indicate both wells encountered a sandy layer that stopped advancement of the well drilling due to excessive caving.
 - Proposing to contain drill cuttings/fluids in above ground steel pits for transportation / disposal to City property by Layne. Disposal of this discharge maybe difficult and if discharged to the stream requires a discharge permit.
 - Drilling with mud requires more emphasis on proper development to avoid residual mud from entering the pool or equipment.

Approaches to Address the Issue



- **WWE Recommendation – Design and Replace OX2 Well**

- Develop a well design that utilizes an ODEX air rotary drilling method which advances casing.
- Air rotary drilling method may be a better approach to maintain the open borehole.
- Allows for completion of a well with stainless steel screen to promote well longevity.
- Given the high cost of rehabilitating the OX-2 well, there does not appear to be any cost benefit of rehabilitating over drilling a new well.

- **Advantages**

- Solicit competitive bids from contractors can help minimize construction costs.
- Contract documents can provide the City with protection in the event the well is defective.
- The size of the new well is not limited by the existing casing at OX-2.
- Drill cuttings from the well are more easily disposed of and reduces the amount of fluids that will need to be disposed of during drilling and well development.
- Observation of the drill cuttings without mud can provide better insight regarding the lithology encountered and field modify the proposed well design to increase probability of a productive well.

Proposed OX2 and OX6 Heat Exchange System



- **OX2 and OX6 Stepped Injection Testing – September 2021**

- Tested the structural integrity of well OX6 when water injected under pressure to assess the viability of a potential closed-loop heat exchange system.
- Pressure injected water from a hydrant into OX6 at 100, 200, 300, and 400 gpm.
- Monitored pressure and integrity of OX6 and changes in production rate and temperature at OX2.

- **Findings**

- OX6 appears to have the transmitting capacity of the specified flow rates between 100 to 400 gpm with a max pressure increase to approximately 12.75 psi (@ 400 gpm).
- No observed leaks or casing movement at the OX6 well head. Structural integrity appears intact.
- Average OX2 well temperature decreased by 1.23°F from 121.97°F during the test.
- OX2 well production increased from 134 gpm to 230 gpm (@400 gpm) during the test.
- No measurable impact to flow and temperature to Wiesbaden Hot Springs water during or after the stepped injection test performed on OX6.
- Results suggest a closed-loop heat exchange system is feasible.

Overall Summary and Additional Considerations



- **Summary**

- Temperature and water production from OX2 are trending downward since 2020.
- Current proposal to rehabilitate OX2 uses mud and does not have a history of success.
- WWE can develop well design and construction documents that specifies drilling method to give project a higher chance of success and gives the City contractual protections.
- Heat exchange system between OX2 and OX6 appears feasible.

- **Additional Considerations**

- Hot springs water production from OX wells is limited but heat is available from OX wells through heat exchange.
- If OX wells are used for heat exchange, discharge from the pool is only naturally occurring water from Box Canyon Line. May help pool discharge permit (CDPHE).
- OX6, while stable during the testing, may need rehabilitation or replacement in the future if used as an injection well long term. Ongoing monitoring of OX6 is recommended.

Questions?



Thank You!

Hayes Lenhart, P.E.
Wright Water Engineers, Inc.
(970) 259-7411
hlenhart@wrightwater.com

WWE

Wright Water Engineers, Inc.

Ouray Hot Springs

Legend

- Box Canyon Line - Notable Features
- ▲ Hot Springs Locations (from WWE 7-30-2015 Site Visit)

Box Canyon Line Sampling Locations

- ⊗ Historically Monitored
- Currently Monitored
- Estimated Biota Line Alignment
- Box Canyon Line - Approximate Length 5,200 ft
- OX-2 Line to Pool
- ~ Streams and Rivers

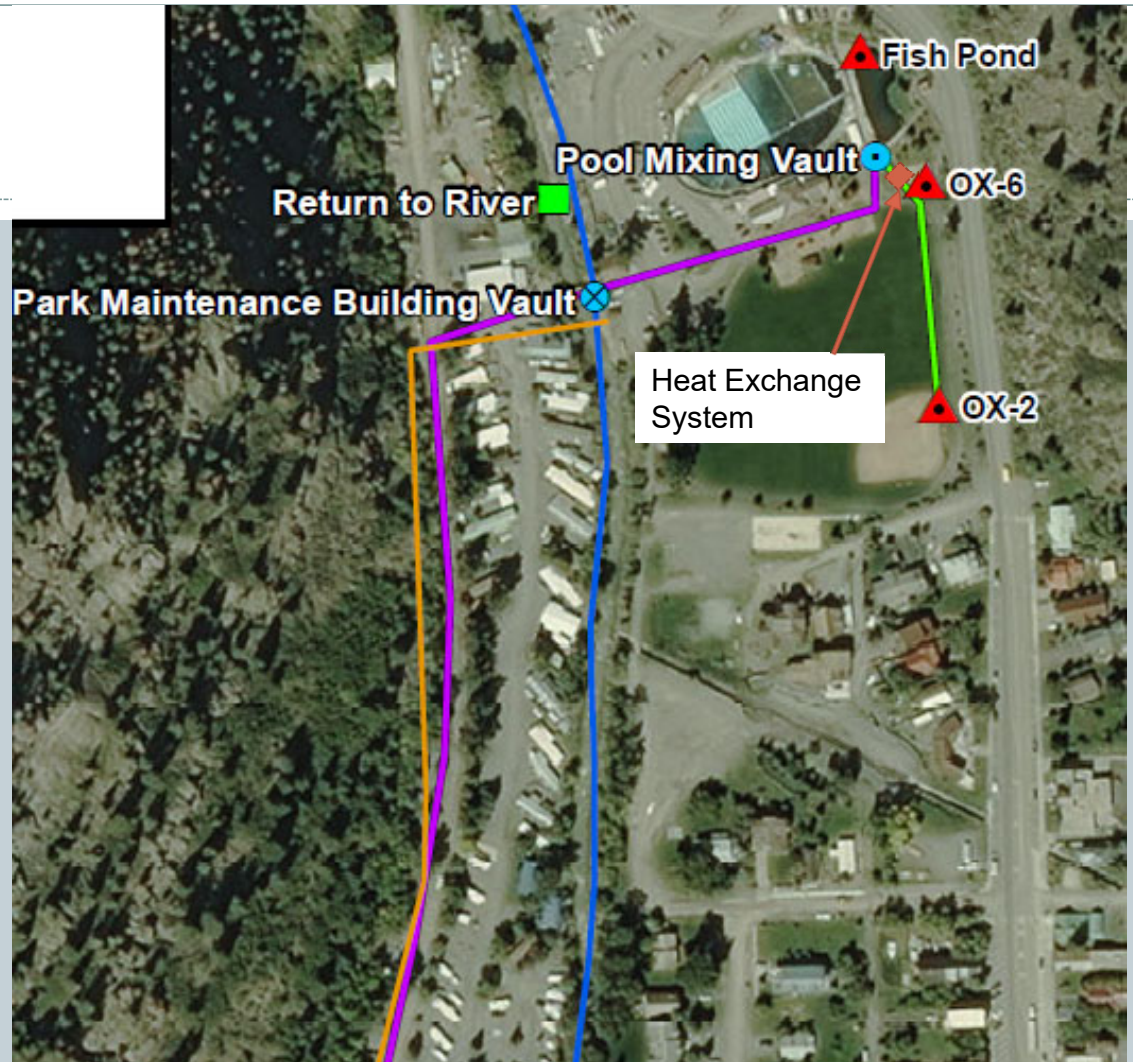

OX2 and OX6 Stepped Injection Testing

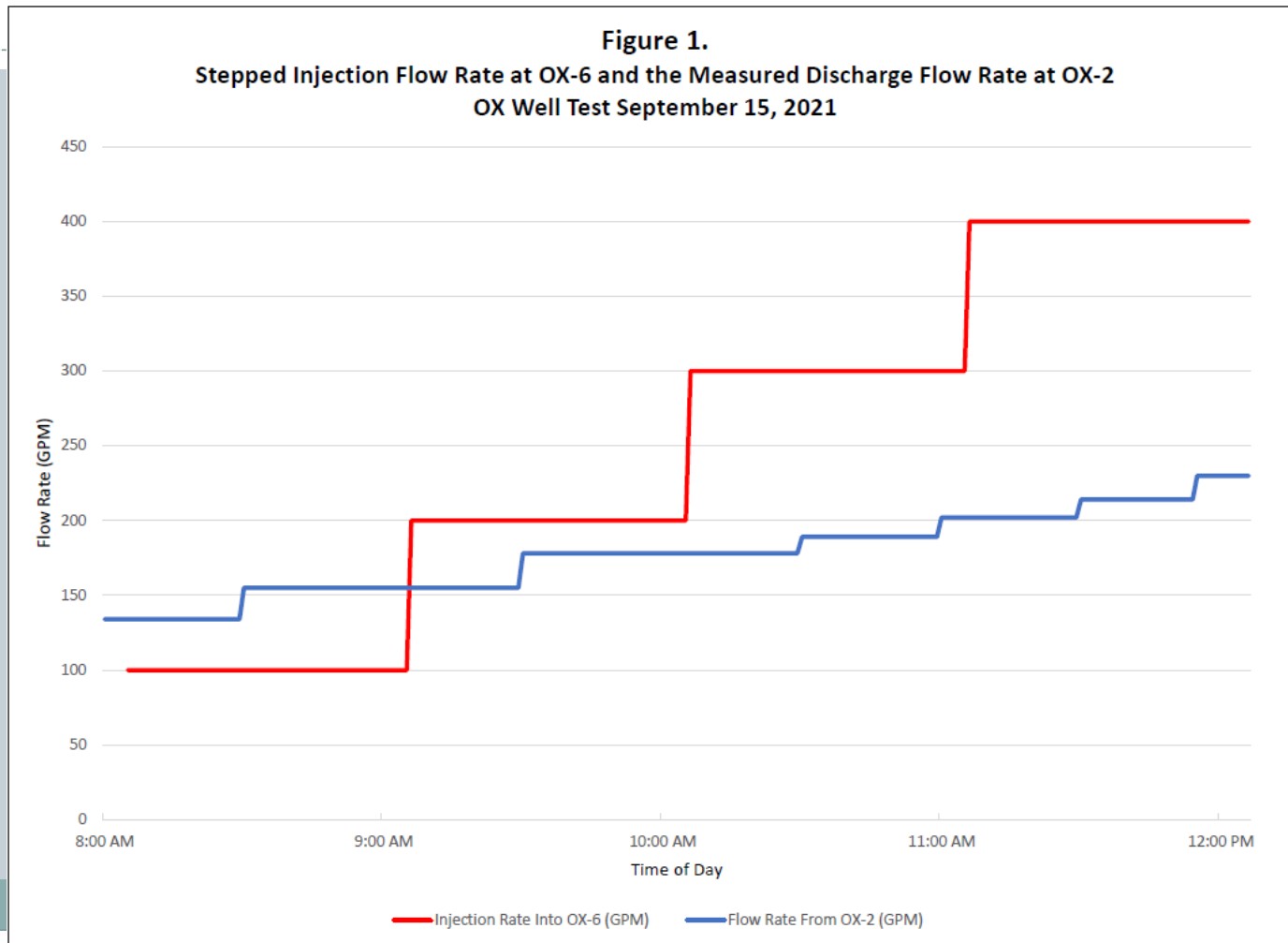

OX2 and OX6 Stepped Injection Testing

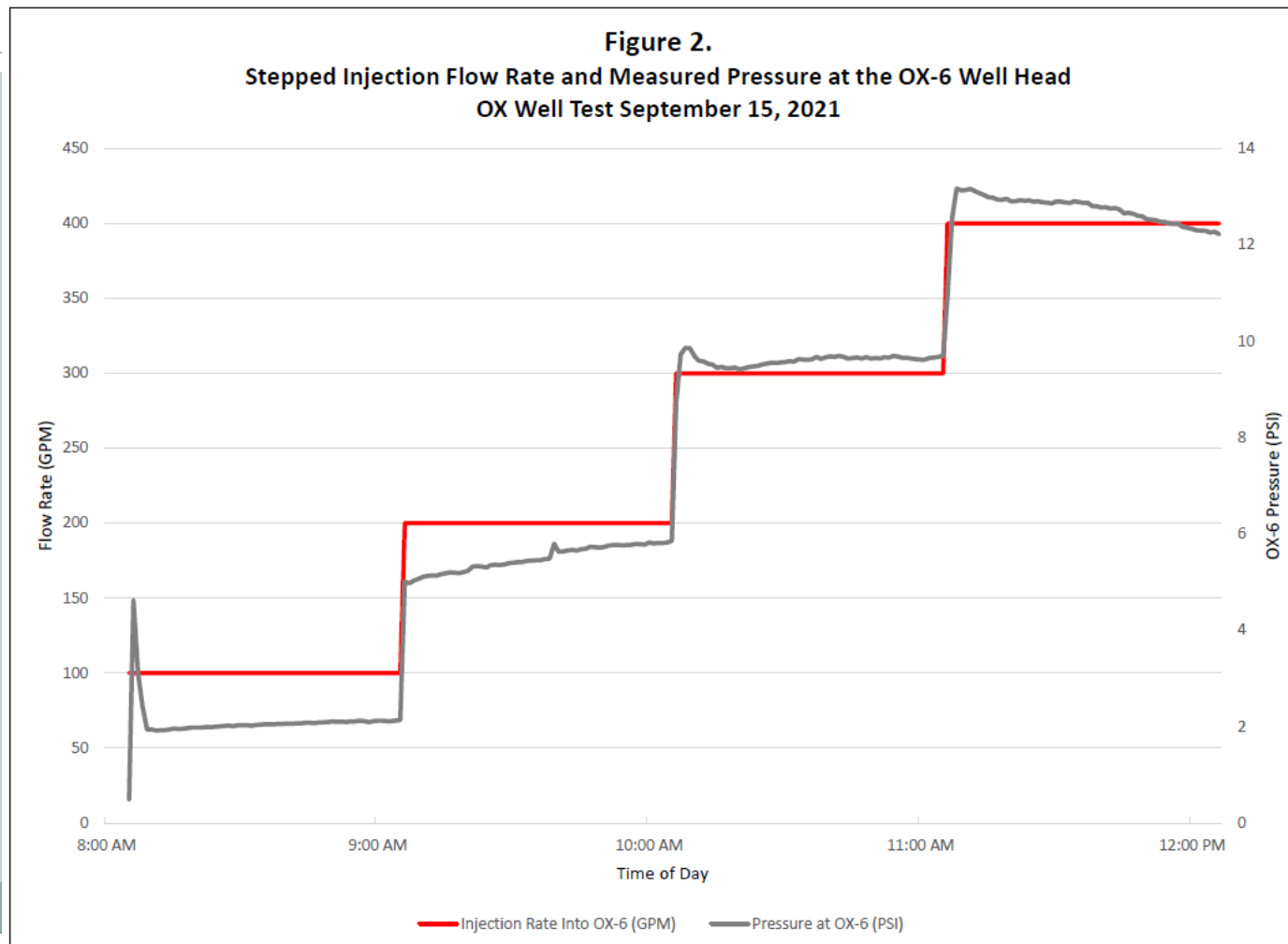

OX2 and OX6 Stepped Injection Testing

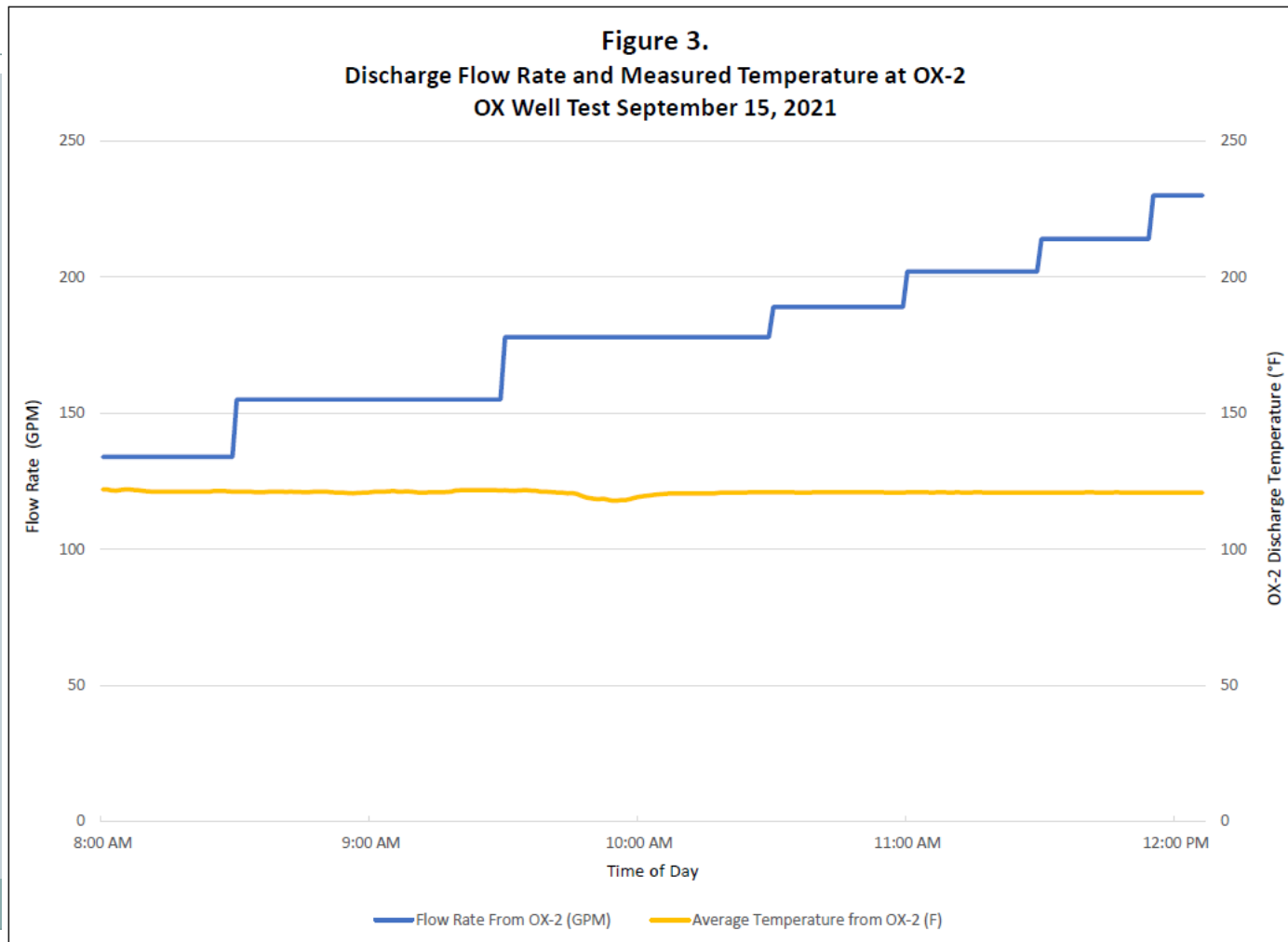

City of Ouray - Hot Springs Pool Size (Old vs. New)

	Previous Pool		Current Pool	
	Square Footage	Gallons	Square Footage	Gallons
Lap Pool	5,170		5,383	201,338
Hot Pool	1,360	26,930	4,212	110,278
Shallow Pool	7,900	203,450	7,900	177,288
Activity Pool	9,370	792,480	6,635	277,946
Overlook Pool	5,200		3,000	89,766
Totals	29,000	1,022,860	27,130	856,616

ME&E ENGINEERING

572 E 3rd Ave, Suite A
Durango CO 81301

970-385-1570

Ouray Hot Springs Pool Assessment Prepared for the City of Ouray

Date: July 20, 2022

Prepared by
ME&E Engineering
572 E. 3rd Avenue, Suite A
Durango, CO 81301

INTRODUCTION

In late February 2022, Joe Coleman reached out to ME&E Engineering for help finding mechanical options for heating the Ouray Hot Spring Pool. On March 18, 2022, ME&E representatives, Mechanical Engineer and Principal Dustin Sullivan and Technical Writer Nana Naisbitt met with the following city representatives at the Ouray Pool: Public Works Director Joe Coleman, Pool Manager Carmen Brashier, City Manager Silas Clarke, and Filtration Manager Director Joe Cruz. Sullivan and Naisbitt toured the Ouray Hot Spring Pool facility with these city representatives to collect information about current conditions and determine which test results and documents would be needed from the city. All documents requested by ME&E were subsequently provided by the city staff. On June 6, 2022, Sullivan spoke with Trevor Downing and Hayes Lenhart of Wright Water Engineers to better understand existing conditions.

ISSUES, AS STATED BY CITY STAFF

- ME&E learned that there are three sources of hot springs water that feed the pools. Collectively they currently provide an average of 210 gallons per minute, according to Joe Cruz and Silas Clarke. The three sources are: 1) Box Canyon Line; 2) OX2 Artisan Well; and 3) The Ball Park Line. The current combined flow rate of 210 gpm is well below the historic flow rate of about 300 gpm, which in the past provided enough flow to heat the pools with no additional mechanical heating
- During the Step Test conducted by Wright Water Engineers, the natural pressure was measured at 3psi, which is related to flow rate
- The city must shut down the OX2 line one day per week to be in compliance with an agreement with the Wiesbaden Spa. Currently that closure day is Tuesday. The city and residents would prefer that the pool be open seven days a week
- Under current natural conditions, ideal temperatures in the pool are difficult to maintain in the winter months
- Historically, the primary source of water for the pools came from the OX2 Artisan Well, however the output of that well has decreased from about 200 gallons per minute to about 110 gallons per minute, and sometimes less. The heat loss of the pools is greater than the heat gain due to the reduced flow, causing uncomfortably cool pool conditions. OX6 seems intact according to the Wright Water Engineers and videos. No one is certain what is causing the reduced flow
- The lap pool is ideally maintained at 80°F. However, under current natural conditions in the winter, the temperature does not get above 76°F, and if the lap pool temperature drops to 72°F, then the pool is closed
- In the winter months, the shallow pool is shut down with the exception of about a 20% section, which is kept open so children can cool down, even if the temperatures drop to 70°

GOALS AND PRIORITIES, AS STATED BY CITY STAFF

- A hot springs flow rate of 300 gallons per minute or more is ideal
- Get the Overlook Pool up to 106°F, but no cooler than 104°F in the winter months
- Get the Hot Pool up to 106°F, but no cooler than 100°F in the winter months

- Get the Shallow Pool up to 98°F, but no cooler than 92°F in the winter months
- Get the Lap Pool up to 80°-82°F, but no cooler than 78°F in the winter months
- Open all pools every day all year round at full water levels (except the Activities Pool, which is open seasonally from Memorial Day to Labor Day)
- Heat the pools even on the day of the week when the city shuts off the feed from the OX2 well; in other words, remain open seven days a week
- Prevent the need to lower water levels in the pools because that causes tiles and plaster to crack
- Ideally, the OX2 Well would return to its historic output of 200 gallons per minute, however this is unpredictable

POSSIBLE SOLUTIONS

Below, ME&E outlines four possible mechanical solutions, but our assumption is that the primary heat source will remain the earth's aquifer and flowing natural water for all these systems. However, because of the issues experienced at the Ouray Pools as outlined above, the Ouray staff members have asked ME&E Engineering to suggest mechanical solutions. All the mechanical systems below will serve as a back-up to the natural system.

Option #1 Heat Exchanger Only

In addition to the existing open loop hot springs heating system, provide a new closed loop system that uses hot springs water and a heat exchanger to provide heat. This option would require a new stainless-steel plate-and-frame heat exchanger and two new pumps. Natural hot springs water would be pumped at 300gpm off the OX2 Well through the hot side of the heat exchanger and back into the OX6 Well. Pool water would be pumped from the coldest pool at 78°F through the cold side of the heat exchanger; it would be heated up via the heat exchanger, and then pumped into the hottest pool at 110°F. None of the natural hot springs water would leave the aquifer. All current chlorination and filtration systems would remain. All the equipment would be housed in a new insulated pump house.

If the natural hot springs water temperatures drop while using this system, pumps would be slowed or turned off to maintain the average aquifer temperature of 121°. But, if the incoming natural water temperatures dropped, the only recourse would be to go back to the natural flow and uncomfortably cold pools. The City of Ouray might want to be "boiler ready" if it chooses this option because this system is the least capable of solving the issues described above.

This system could be web-based controlled and transparent to any authorized user. Credentials could be assigned to be "read-only."

(See Option #1 Diagram for more details.)

Advantages:

- Least costly to install
- Least costly to run

- The only energy cost is running the pumps

Disadvantages:

- May disrupt the flows and temperatures of the natural hot springs, if not controlled properly
- Must continue to close one day per week, as per agreement with Wiesbaden
- If the aquifer fails to provide heat, and/or the flow rates continue to decrease over time, this system will fail to provide the desired pool temperatures
- There may be a risk in choosing the heat exchanger system: It is unknown how this system might affect the long-term temperature of the aquifer
- This risk could be mitigated by building in controls that stop the hot springs pump, if natural water temperatures drop below 121°

Option #2 Boiler Plant

Provide a new boiler plant with an input of 6,000,000 Btu/hr to the property to directly heat the pool water. None of the natural hot springs water would run through the new boiler system, only chlorinated pool water. All current chlorination and filtration systems would remain. All the equipment would be housed in a new insulated pump house.

(See Option #2 Diagram for more details.)

Advantages:

- Highly dependable heat source
- Open 24/7/365 with hot pools
- Will not disrupt the natural hot springs aquifer

Disadvantages:

- Highest energy costs
- Fossil fuel dependent
- High upfront costs

Option #3 Heat Exchanger and Back-up Boiler Plant

This option is a combination of Option #1 and Option #2. The heat exchanger would be the primary mechanical heat source. The boiler system would only kick on when the heat exchanger is unable to meet desired temperatures. All current chlorination and filtration systems would remain. All the equipment would be housed in a new insulated pump house.

This system could be web-based controlled and transparent to any authorized user. Credentials could be assigned to be “read-only.”

(See Option #3 Diagram for more details.)

Advantages:

- Highly dependable heat source
- Open 24/7/365 with hot pools
- Not totally reliant on fossil fuel; the fossil-fuel-dependent system is the secondary back-up
- Less costly to run than total reliance on boiler system
- More energy efficient than total reliance on boiler system
- If the aquifer fails to provide heat, and/or the flow rates continue to decrease over time, this system would still provide the desired pool temperatures

Disadvantages:

- May disrupt the flows and temperatures of the natural hot springs aquifer, if not controlled properly
- High upfront costs

Option #4 Solar Thermal with Back-up Boiler

As the primary back-up system, pool water would be heated through the solar thermal panels. This system would require approximately 60 solar panels 8' x 4' each, or about 2,000 square feet. When the flow rate of the natural water is not sufficient and/or when the natural water temperatures are too low, pool water would be pumped off the pool into the panels; then heated pool water from the panels would be pumped back into the pools. The boiler would only kick on when the solar thermal is unable to meet desired temperatures, such as on a cloudy day (see Option #2 for description of the boiler system). All current chlorination and filtration systems would remain.

(See Option #4 Diagram for more details.)

Advantages:

- Highly dependable heat source
- Open 24/7/365 with hot pools
- Will not disrupt the natural hot springs aquifer
- Not totally reliant on fossil fuel; the fossil-fuel dependent system is the secondary back-up
- Less costly to run than total reliance on boiler system
- More energy efficient than total reliance on boiler system
- If the aquifer fails to provide heat, and/or the flow rates continue to decrease over time, this system would still provide the desired pool temperatures
- Heating only chlorinated pool water

Disadvantages:

- Need sunshine to run the solar system
- Highest upfront costs of all four systems
- Shorter days in the winter means less efficiency when needed most

- This system requires approximately 2,000 square feet for a solar thermal panel array

METHOD FOR ESTIMATION OF INSTALLATION COSTS

Construction estimates are helpful when making decisions about which system to choose. RS Means cost estimating guides are nationally recognized standards for construction cost estimating. The publisher produces a number of specific estimating guides, including *2022 Mechanical Cost Data*, *2022 Electrical Cost Data*, and *2022 Plumbing Cost Data*. Construction costs herein are based on 2022 RS Means cost estimating guides. However, it should be highlighted that we are in a high inflationary period, with many uncertainties.

COST ESTIMATE TABLE

ITEM	HEAT EXCHANGER		BOILER	HX/BOILER HYBRID	SOLAR THERMAL
	OPTION#1	OPTION#2	OPTION#3	OPTION#4	OPTION#4
Architectural	\$96,000	\$96,000	\$96,000	\$96,000	\$96,000
Mechanical	\$97,441	\$283,741	\$357,159	\$387,319	\$387,319
Electrical	\$29,355	\$29,433	\$30,515	\$29,433	\$29,433
Controls	\$44,126	\$41,085	\$44,607	\$41,085	\$41,085
TAB contractor	\$1,300	\$1,300	\$1,950	\$1,300	\$1,300
Plumbing	\$33,765	\$43,449	\$43,449	\$43,449	\$43,449
Sub-total	\$301,987	\$384,508	\$463,179	\$488,086	\$488,086
GC Markup	10%	\$30,199	\$38,451	\$46,318	\$48,809
Contingency	10%	\$30,199	\$38,451	\$46,318	\$48,809
Total		\$362,385	\$594,011	\$688,417	\$718,305

ATTACHMENTS

- Option #1 Diagram
- Option #2 Diagram
- Option #3 Diagram
- Option #4 Diagram

NOTE: ALL TEMPERATURES AND PRESSURES REPORT TO THE FACILITY MANAGEMENT SYSTEM. ALL TEMPERATURE AND PRESSURE SETPOINTS SHALL BE ADJUSTABLE.

- (T1) IF TEMPERATURE DROPS BELOW 120°F REDUCE HOT SPRINGS PUMP SPEED.
- (P1) IF PRESSURE DROPS BELOW 10W.C. ENABLE HOT SPRINGS PUMP AND OPEN CONTROL VALVE#1. IF ACTIVE AND THE PRESSURE DROPS BELOW 10W.C. INCREASE HOT SPRINGS PUMP SPEED.
- (T3) IF TEMPERATURE DROPS BELOW 80°F ACTIVATE POOL PUMP AND HOT SPRINGS PUMP. POOL PUMP SPEED TO MAINTAIN A CONSTANT 80°F TEMPERATURE. POOL PUMP AND HOT SPRINGS PUMP DEACTIVATE WHEN TEMPERATURE RISES ABOVE 84°F.
- (T2) (P2) (T3) (P3) (T4) (P4) TEMPERATURES AND PRESSURES RECORDED FOR DIAGNOSTICS ONLY

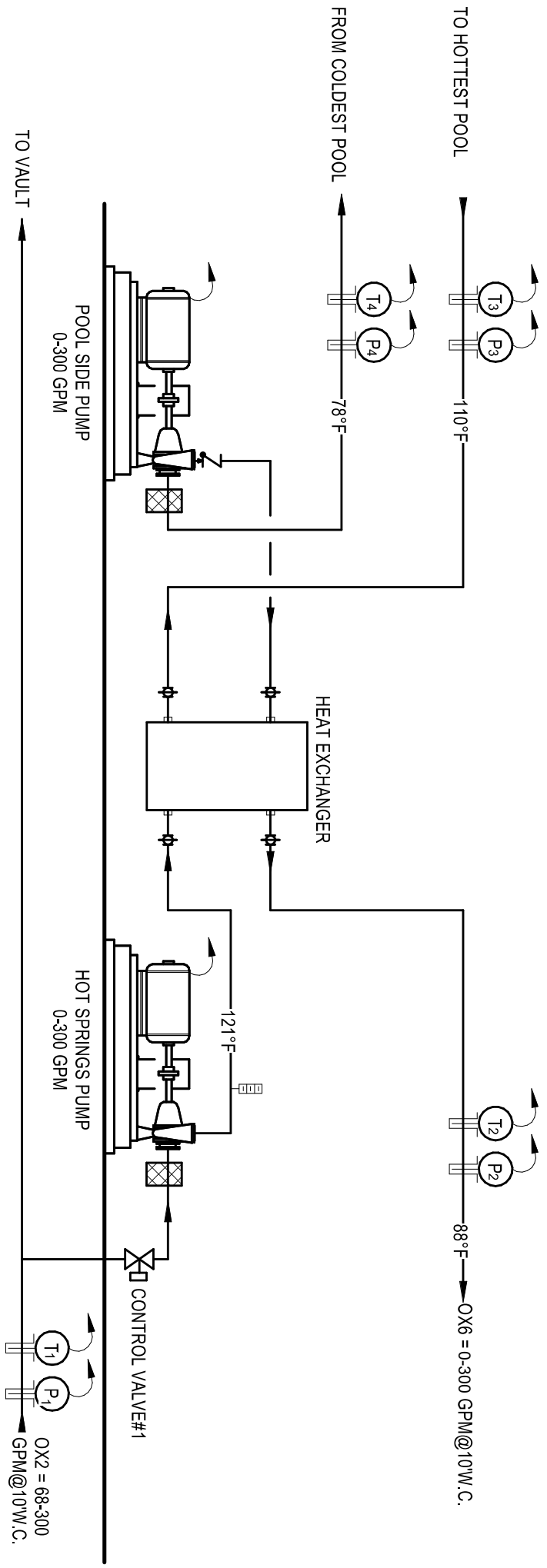

1

HX PIPING DIAGRAM

NOTE: ALL TEMPERATURES AND PRESSURES REPORT TO THE FACILITY MANAGEMENT SYSTEM. ALL TEMPERATURE AND PRESSURE SETPOINTS SHALL BE ADJUSTABLE.

T1 IF THE COLDEST POOL TEMPERATURE DROPS BELOW 78°F ACTIVATE THE PUMP AND BOILER TO MAINTAIN 78°F .

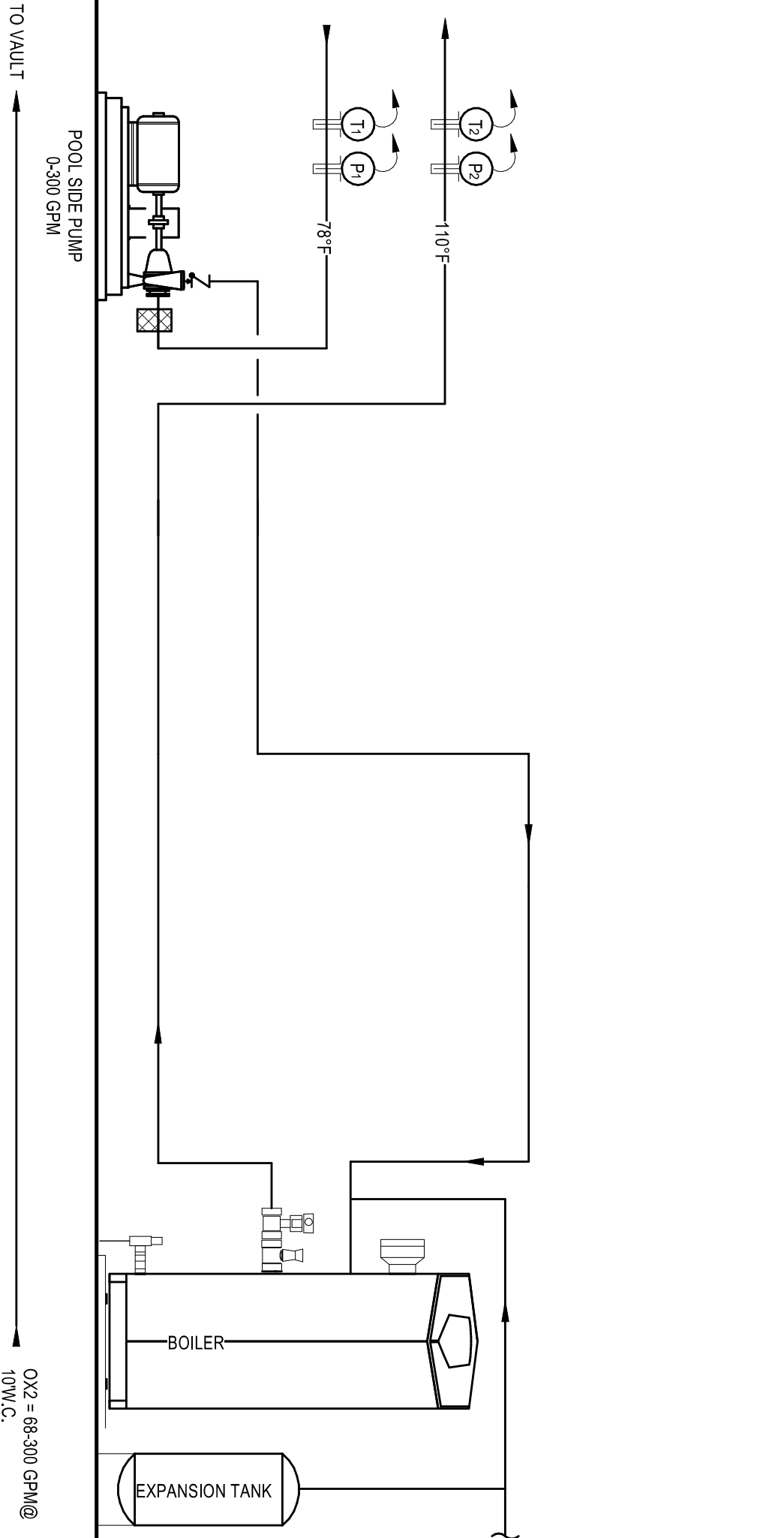

2

BOILER PIPING DIAGRAM

NOTE: ALL TEMPERATURES AND PRESSURES REPORT TO THE FACILITY MANAGEMENT SYSTEM. ALL TEMPERATURE AND PRESSURE SETPOINTS SHALL BE ADJUSTABLE.

- (T1) IF TEMPERATURE DROPS BELOW 120°F REDUCE HOT SPRINGS PUMP SPEED. IF TEMPERATURE DROPS BELOW 115°F CLOSE CONTROL VALVE#1 AND #2 TO THE HOT SPRINGS AND OPEN TO THE BOILER SYSTEM. ACTIVATE BOILER TO MAINTAIN TEMPERATURES.
- (P1) IF PRESSURE DROPS BELOW 10W.C. ENABLE HOT SPRINGS PUMP AND OPEN CONTROL VALVE#1. IF ACTIVE AND THE PRESSURE DROPS BELOW 10W.C. INCREASE HOT SPRINGS PUMP SPEED.
- (T3) IF TEMPERATURE DROPS BELOW 80°F ACTIVATE POOL PUMP AND HOT SPRINGS PUMP. POOL PUMP SPEED TO MAINTAIN A CONSTANT 80°F TEMPERATURE.
- (T3) IF TEMPERATURE DROPS BELOW 80°F ACTIVATE POOL PUMP AND HOT SPRINGS PUMP. POOL PUMP SPEED TO MAINTAIN A CONSTANT 80°F TEMPERATURE.

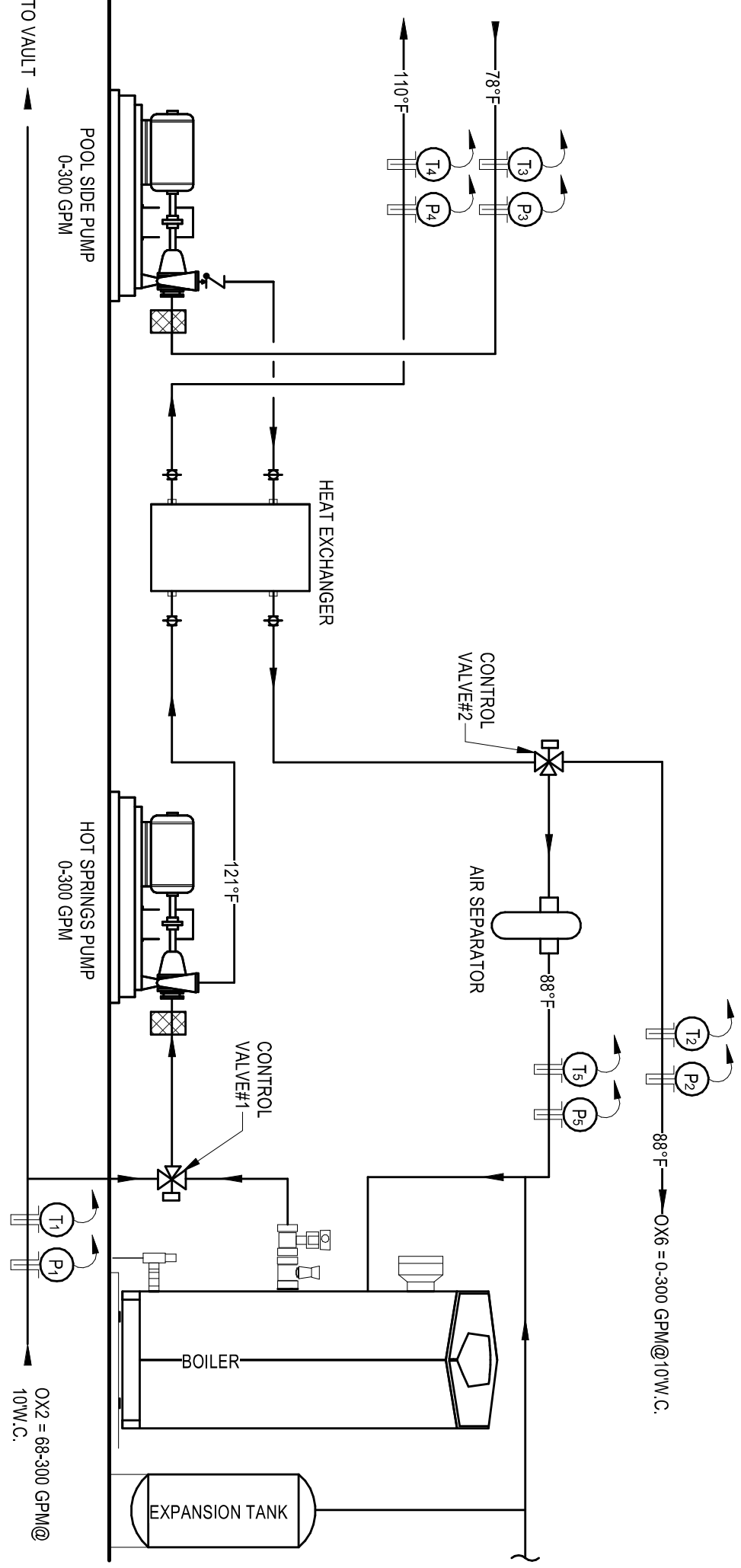

HX/BOILER PIPING DIAGRAM

NOTE: ALL TEMPERATURES AND PRESSURES REPORT TO THE FACILITY MANAGEMENT SYSTEM. ALL TEMPERATURE AND PRESSURE SETPOINTS SHALL BE ADJUSTABLE.

T1 IF THE COLDEST POOL TEMPERATURE DROPS BELOW 78°F ACTIVATE THE PUMP TO MAINTAIN 78°F .

T3 IF THE WATER TEMPERATURE DROPS BELOW 110°F CONTROL VALVE#1 SHALL DIVERT FLOW TO BOILER LOOP AND CONTROL VALVE#2 DRAINS TO THE POOL. IF THE WATER TEMPERATURES RISE ABOVE 120°F CONTROL VALVE#1 SHALL DIVERT WATER TO THE BOILER LOOP AND CONTROL VALVE #2 SHALL DIVERT WATER TO A POOL.

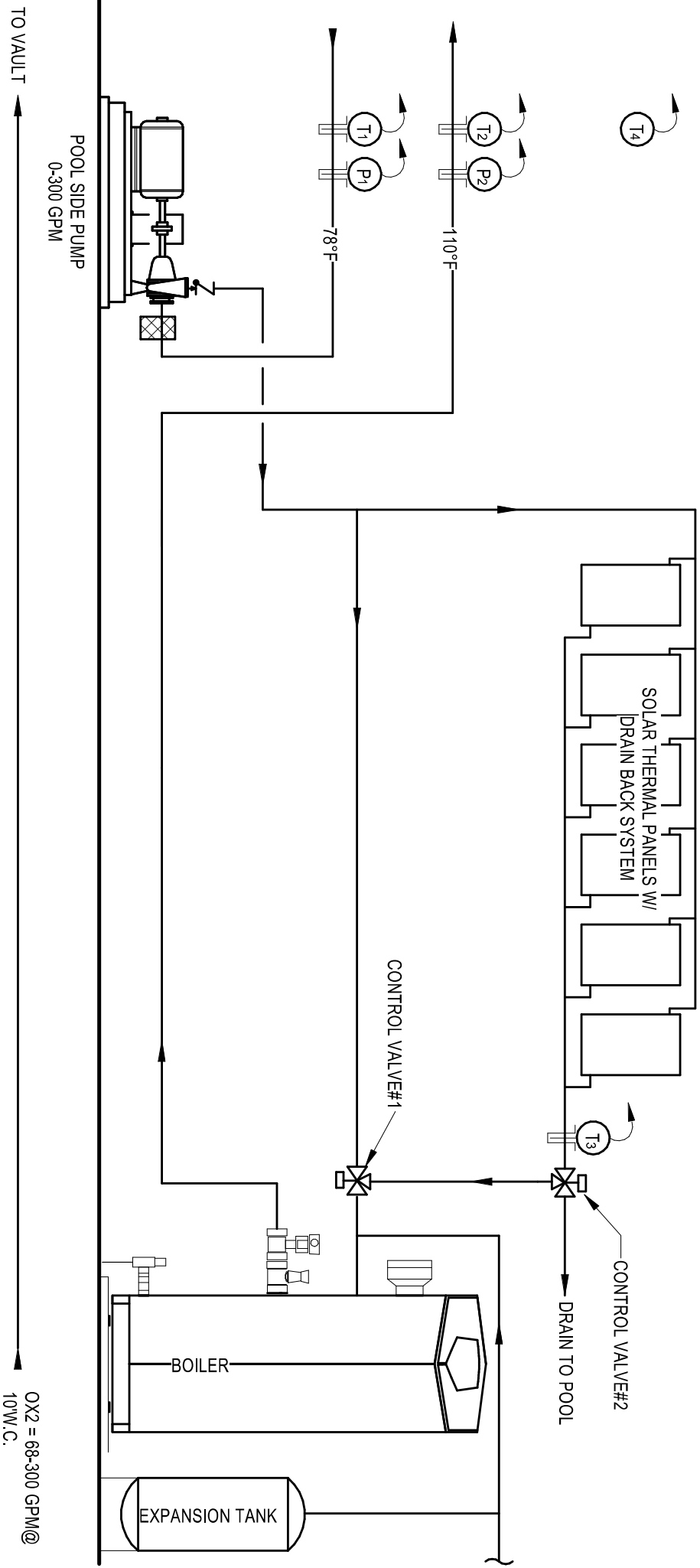

OX2 = 68-300 GPM@
10W.C.

4

SOLAR THERMAL DIAGRAM

