



June Facilities, Finance & Operations Committee Meeting  
Friday, June 12, 2026  
9:00 AM  
Zoom Webinar

---

- I. IAQ Report Update
- II. Update of Facilities and Grounds Maintenance
- III. FY26 Monthly Financial Update (through May) Including Internal Services
- IV. Approval of May Financial, Facilities and Operations Committee Minutes
- V. Other Business



**TO:** BOE Finance & Operations Committee

**FROM:** Phillip Cross, Chief Financial & Operations Officer

**DATE:** June 12, 2026

**Subject:** 5 Year IAQ Report

---

In order to maintain healthy air quality in schools, recently passed legislation requires that for the period commencing July 1, 2026, and ending June 30, 2031, each school district shall provide for a uniform inspection and evaluation of the heating, ventilation and air conditioning (HVAC) system within each school building under its jurisdiction. Each school must be inspected every five years thereafter.

The inspections must be performed by a certified technician, an industrial hygienist, or a mechanical engineer. To meet this requirement, in April we had the HVAC systems at HES, WIS and WHS inspected by Pennoni, the engineering company we use for our IAQ and various other testing. Attached are the full results of this inspection.

We have deferred testing for the middle school until we have a better indication as to the plans for the building.

Below is an overview of the status of the HVAC systems.

Hurlbutt Elementary	Location	Vintage	Note	Action Priority			
				High	Medium	Low	
<b>Air Handling</b>							
	Central 5 AHUs	Indoor - Mezzanine	1997	OA damper issues		X	
	Central zone coils	Indoor - Mezzanine	1997	Not reviewed			X
	North House RTU	Outdoor - Roof	unknown	Not reviewed. No OA to room N9 when unit is off. (only used for cooling)			
	North House Gym AHU Cooling	Indoor - Mech room	unknown	Not functional		X	
	North House Gym AHU Heating	Indoor - Mech room	unknown	OA damper non-functional. Exposed motor and fan belt - no safety covering	X		
	North House Outdoor Air unit	Indoor - Mech room	unknown	Supplies OA to 8 classrooms and corridors Pneumatic face/bypass and isolation damper controls			X
	North House Dehumidification Unit	Indoor - Mech room		Not reviewed			
<b>Unit Ventilators</b>							
	11 UVs	Indoor - Classrooms	before 1997	Pneumatic control - manual on/off - 11 units	X		
	4 UVs	Indoor - Classrooms	1997	BAS Control		X	
<b>South and East House</b>							
				No Mechanical ventilation	X		
<b>Controls</b>							
	Allerton DDC						
<b>Operational Issues</b>							
	Address lack of outdoor air control on Central Mezz AHUs				X		
	Address filter bypass causing dirty coil						
	Address lack of outdoor air to Room N9 when RTU is not operating						
	Address lack of outdoor air to North Gym (cooling unit inoperable, heating unit inoperable OA damper)						
	Address safety of exposed fan belt outside unit						
	Operate UVs continuously during occupied hours to provide outdoor air						
	Address South and East House lack of mechanical ventilation						

Intermediate School	Location	Vintage	Note	Action Priority			
				High	Medium	Low	
<b>Multi Zone Rooftop units</b>							
	RTUs (1,2,4,5)	Outdoors - Roof	2003	Air flows below design. Fixed min OA damper can result in less than required OA at low system flows. Filter bypass causing dirty coil.	X		
	VAV terminals	Rooms	2003	Create VAV summary tables			X
<b>Single Zone Rooftop Units</b>							
	RTUs (3,6,7)	Outdoors - Roof	2003	Damper issues Filter bypass causing dirty coil		X	
<b>Controls</b>							
	Allerton DDC						
<b>Operational Issues</b>							
	Address limited system air flow in Multi-zone units				X		
	Address filter bypass causing dirty coil (RTU-1,7)						
	Address relief damper actuation possibly impacting outdoor air (RTU-3,7)						

High School					Action Priority		
					High	Medium	Low
<b>Unit Ventilators</b>							
	13 UVs	C Wing Classrooms	pre 2003	BAS control		X	
	10 UVs	D Wing Classrooms	pre 2003	pneumatic control	X		
<b>VRF /DOAS system</b>							
	DOAS unit	E Wing Roof	post 2003	Filters missing in DOAS unit			X
	VRF compressor units	E Wing Roof		Not reviewed			
<b>Multi-Zone RTUs (1,2,4,5,7)</b>							
	RTUs	Roof	2003			X	
	VAV terminals	Rooms	2003	RTU-5 VAV summary is incomplete			X
<b>Single Zone RTUs (3,6,8,9, HV-1,2, Aud)</b>							
	RTUs	Roof	2003			X	
<b>Controls</b>							
	Allerton DDC						
<b>Operational Issues</b>					X		
	Address UV control to operate fan continuously during occupied period to provide outdoor air						
	Install missing filters in dedicated outdoor air unit						
	Address erratic supply duct pressure sensor impact on fan speed control in RTU-1						
	Address VAV air terminal airflows that report above set point when damper is closed (RTU-1,2,5,7)						
	Address low outdoor air flow (RTU-4,7)						
	Review coordination of RTU-5 outdoor air flow with exhaust fan and hood operation for potential energy savings						
	Address outdoor air damper actuation (RTU-6, 9, HV-2)						



**WESTON PUBLIC SCHOOL DISTRICT  
UNIFORM HVAC INSPECTION AND EVALUATION  
2026**

**Weston Public Schools District**

Attn. Andrew Galli  
Finance & Operations Office Manager  
24 School Rd.  
Weston, CT 06883  
203-221-6559  
[andrewgalli@westonps.org](mailto:andrewgalli@westonps.org)

**RE: UNIFORM HVAC INSPECTION AND EVALUATION  
Weston Public School District  
Weston, CT**

Dear Mr. Galli.

**Pennoni** is pleased to submit this report for the uniform HVAC inspection and evaluation performed in February 2026. Included in the assessment were Weston High School, Weston Intermediate School and Hurlbutt Elementary School.

In partnership with our HVAC assessment specialist, the inspection and evaluation were conducted in accordance with the Connecticut Department of Administrative Services (DAS) requirements related to indoor air quality and the inventory of HVAC equipment. The assessment focused on each school building's major HVAC systems, including air handling units (AHUs) and packaged rooftop units (RTUs).

The following sections of this report provide an overview of the status of the HVAC systems to help prioritize replacement planning. They also include a summary of each school's HVAC systems, their current condition, and any identified issues.

Attachments.

1. Weston High School Report
2. Weston Intermediate School Report
3. Hurlbutt Elementary School Report
4. Supplemental Action Priority Information

Please call me if you have any questions or if I can be of further assistance.

Regards,

**78D 790**

Ted Tio, MS, CIEC  
Senior Industrial Hygienist

**ATTACHMENT 1.  
WESTON HIGH SCHOOL REPORT**

**HVAC Ventilation Review**  
**Weston School District**  
**Weston High School**

2/27/2026

*Scope*

The HVAC systems were inspected from 2/17 to 2/20 to evaluate operation with emphasis on ventilation. This report summarizes the systems and describes the ventilation operation as found and reviewed on site. Observations cover outdoor entry paths, filters, and control system review.

*Key Findings*

- Unit ventilators (controlled by the BAS) appear to cycle the fan and outdoor air damper with calls for heat, resulting in no outdoor air delivery while cycled off.
- The W-wing dedicated outdoor air system is missing filters on both the outdoor air intake and exhaust intake to the heat exchanger wheel that tempers the air. This unit supplies outdoor air directly to each classroom in the E wing. Currently the air is unfiltered.
- Variable air volume rooftop units are maintaining a fixed minimum outdoor air damper position. This means that the outdoor air varies with the system flow. This can cause inadequate outdoor airflow at low loads. RTU-4 and 7 show low outdoor air flows.
- At least 13 VAV air flow terminal boxes have issues with their damper control or air flow measurements. They report excess air flow when the dampers are commanded closed. Proper air flow to each space is needed to ensure that outdoor air is distributed well throughout the system.
- The air terminal summary of the science area VAV boxes is incomplete inhibiting a comparative system flow measurement. The unit outdoor air flow is driven by exhaust air needs. The mixed air temperature near a lower limit shows that adequate outdoor air is being provided to the science building for occupant requirements. The outdoor air should be reviewed in coordination with the fume hood exhaust requirements.
- Several single zone rooftop units show little variation in outdoor air flow with changes in outdoor air damper position or show excessive outdoor flow with the dampers commanded closed. The outdoor air damper actuators should be reviewed on these units (RTU-6,9, HV-2)

High school classrooms are served by several system types: central variable air volume air handlers, unit ventilators, and variable refrigerant flow with dedicated outdoor air system. Common areas are served by single zone air handlers. The air handlers were installed as part of a 2003 remodel based on mechanical drawings.

*Unit Ventilators*

Thirteen classrooms in C and D wings use unit ventilators that are controlled through the building automation system (BAS). Ten classrooms in the D wing use unit ventilators with local pneumatic controls. These cabinet units installed beneath a window have an internal outdoor air damper to provide outdoor air from a louver in the brick facade directly behind the units. The outdoor air is mixed with air pulled through the bottom of the cabinet then through a filter by fans mounted just below the grate that delivers air to the space. Units controlled through the BAS note sensed occupancy status, but three rooms note that the sensor is disabled. Pneumatically controlled units presumably have a manual fan switch. Snapshots of the BAS controlled units suggest that the units are cycling the fan and outdoor damper with calls for heat. The fans must run continuously, and outdoor dampers opened to a minimum position during occupied periods to provide the minimum required outdoor air.

*VRF/DOAS system*

Wing E uses a distributed variable refrigerant flow system with a dedicated outdoor air unit. This system replaced classroom unit ventilators. UVs were shown on drawings from 2003 in wing E. The VRF/DOAS system was installed after 2003 as VRFs were first introduced into the United States in 2003. No mechanical drawings of the VRF/DOAS system were provided. The VRF units in each classroom provide heating and cooling with recirculated air in each room. Each room has an outdoor air duct and exhaust duct located on the wall adjacent to the hallway. Central supply and exhaust ducts are routed through the halls above a drop ceiling.

Take-offs (presumably with a balance damper) connect the central ducts to each room. The DOAS unit on the roof uses the collected exhaust air to precondition outdoor air using a wheel type heat exchanger. This heat exchanger is a spinning desiccant wheel partially in both air streams that transfers heat and moisture between the exhaust and supply without cross contamination. A gas burner heater and DX cooling coil provide final temperature control to maintain a neutral supply temperature (room temperature) to the system.

The DOAS unit is missing filters in both the outdoor air stream and the exhaust stream. It is supplying unfiltered outdoor air to the classrooms. The exhaust filters are meant to be installed upstream of the desiccant wheel heat exchanger to protect it from fouling and losing heat transfer effectiveness. The supply filters do the same with the added task of filtering the outdoor air supplied to the classroom. Without filters the wheel has some self-cleaning capability as supply air enters in one direction through half of the wheel as exhaust air passes through the other half of the wheel in the other direction.

The BAS indicates that the DOAS has a return air mixing damper to limit the amount of outdoor air entering the system. This damper was not observed from the filter access hatches. It is unclear why this damper would be in the unit (possibly for frost protection or defrost of the wheel?). Modern units sometimes include this damper because they are standard configurations that have had a wheel added to them. The BAS display indicates that there is some return air mixing with the outdoor air reducing the overall outdoor air flow.

Air flow velocity measurements at supply and exhaust registers in a sample of classrooms show an average of 147 cfm of outdoor air and 99 cfm of exhaust per classroom. This calculation assumes a 75% free area in the 5x12 inch grill and that the supply is the side with the highest air flow. Applying the average to 12 classrooms in the E-wing the total outdoor air should total at least 1,800 cfm. There are also supply grilles for the corridors. The DOAS unit is providing outdoor air to the E-wing and should be put into the regular maintenance schedule to install and replace filters.

Rooms	Measurement		Calculation (75% free area)	
	FPM		CFM	
	Left	Right	Supply	Exhaust
E3	286	180	89	56
F8	433	565	177	135
E10	483	315	151	98
E5	552	342	173	107
Average			147	99

*Multi-Zone Air Handlers*

Classroom and office spaces are supplied by variable air volume rooftop air handlers. Each zone (classroom or small group of rooms) has an air terminal that heats and varies the air flow supplied to the zone based on heating and cooling needs. The air handler responds to the varying air flows by adjusting the fan speed to maintain a supply duct pressure. The original design called for air flow monitoring stations to control the outdoor air dampers so that as the system air flow changed the outdoor air damper would modulate to maintain a constant outdoor air flow. Several of the air flow stations are reading erroneously (e.g. negative values or flow higher than total system flow). Others change value with damper position proportional to an independent flow estimate but might be reading high or low (scaling issue?). The current controls maintain the outdoor damper at a fixed minimum position. The BAS history shows that this minimum damper position has been adjusted over the years. The issue with a fixed minimum is that it is often set and outdoor air verified at full system flow (all the zone air terminals – VAV boxes at their maximum design flow). As the system flow drops with reduced load the fixed damper position causes less outdoor air to be introduced to the system flow stream. This is why the original design called for the outdoor air to be measured and control the damper to maintain the required flow rate across all system flows. Without accurate flow stations it is possible to maintain a steady outdoor air flow by resetting the minimum damper position with supply fan speed. The fan speed is a proxy for system air flow. The current controls don't reset the minimum damper position.

The original design control sequence noted the design system flow, minimum outdoor air flow and zone flow ranges. Typically, a testing and balance report would note the outdoor damper position and airflow station calibration that provides the design outdoor air volume. These records have not been found.

Outdoor airflow is not only influenced by the damper position. The AHUs also have return fans. The difference in speed of the return fan from the supply fan impacts the amount of outdoor air that enters through a partially open damper. Currently all the return fans operate at a fixed speed difference from the supply fan. Most offsets are 10% below the supply fan speed.

Another factor impacting the delivery of outdoor air to rooms is the operation of the air terminal (VAV box). Several boxes reported more than the required air flow with the damper commanded closed. Sensor issues or damper actuation issues can cause this type of error.

With the age of the system at 23 years, it is also possible that balance dampers might not be in their original positions. It is possible that someone could have addressed comfort issues between rooms served by a single VAV box by adjusting the balance damper that impact the distribution of air between rooms. Smaller rooms (e.g. two to four offices) often share a single VAV box with one room containing the thermostat. Additionally, some return paths from rooms through transfer duct to common returns such as corridors are noted by staff to have had smoke dampers that were shut. Blocking the return path disturbs the airflow balance between rooms impacting air flow and comfort.

The outdoor air fraction was estimated by the temperatures of the mixed air stream in the AHU. The outdoor flow rate was then calculated from the OA fraction applied to the sum of the air terminal flows reported in the BAS. The accuracy of this method depends on the mixed air temperature representing the actual mixed air conditions. The sensor is an averaging sensor strung across the air path usually just downstream of the filters or near the first coil. With outdoor air introduced at the edges of the unit and return air introduced through the middle of the unit, the closer the mixed air temperature sensor is to the damper the less likely the air stream has had enough distance to mix well, potentially biasing the reading. The accuracy of the calculated outdoor airflow also depends on the accuracy of the sum of the VAV boxes. As noted earlier some boxes read well above design values with the damper reported closed, suggesting uncertainty in some zone air flows. Understanding the potential uncertainties the BAS data was used to calculate outdoor air flow and compare the values when the system was operated at maximum and minimum flow to show the impact of a fixed damper position on outdoor air delivery.

Multi-Zone VAV RTU Outdoor Air Summary										
	RTU-1		RTU-2		RTU-4		RTU-5		RTU-7	
	Min	Max	Min	Max	Min	Max	Min	Max	Min	Max
System Air Flow (Sum of VAVs)	6,391	9,605	7,917	18,410	2,356	4,029	NR	NR	3,649	6,859
Design Air Flow (2003 schedule)		13,000		21,400		6,400		42,825		8,200
Calculated OA fraction from MA-T	28%	38%	28%	46%	6%	2%	45%	44%	15%	27%
Calculated OA flow	1,821	3,637	2,244	8,406	145	70	NA	NA	539	1,883
Design Min OA flow (2003 Schedule)	1,305	1,305	2,140	2,140	1,305	1,305	25,545	25,545	1,311	1,311
OA AFMS reading	NR	NR	1,593	5,518	387	750	14,406	15,765	NR	NR
OA Damper Position (% open)	20%	20%	15%	15%	10%	10%	10%	10%	9%	9%
Supply Fan Speed	50%	100%	52%	95%	88%	100%	65%	73%	77%	96%
Supply Duct Pressure (in wc)	NR	NR	1.11	0.95	1.13	0.69	0.69	0.64	0.97	0.49
OA Flow Condition	Adequate		Adequate		Needs Attention		Adequate		Needs Attention	

The summary table extracts key items from the calculation tables in the review notes. RTU-4 and 7 outdoor air flows could be improved by increasing the minimum outdoor damper set point and reevaluating. The issues table below notes the individual zone VAV air terminals that need attention to their air flow dampers or flow sensors. Providing adequate outdoor air to individual spaces requires that the air terminals are fully functional. At this point in the equipment life, the air flow stations are not used in the control sequence and are merely informational. If they could be reconditioned and calibrated, they would provide an ongoing verification of outdoor air delivery.

Issues

RTU-1	Outdoor air flow station reading is erroneous.
RTU-1	Duct static pressure probe reads erratically (0.25 to 3.5 in wc) causing the supply fan speed to have poor control, resulting in insufficient air flow at VAV boxes.
RTU-1 50 B40 Green Rm RTU-1 55 Costume Shop	Air terminal damper or flow sensor issue. Reported airflow exceeds set point when damper is commanded closed
RTU-2 14 Media Center Office RTU-2 18 Media Center RTU-2 23 Display/Lobby N RTU-2 24 Workroom	Air terminal damper or flow sensor issue. Reported airflow exceeds set point when damper is commanded closed.
RTU-4	Mixed air temperature implies far less outdoor air than flow measurement shows. Both AFMS and calculated outdoor air flows are less than design minimum outdoor air flow.
RTU-4 46 A29 Office	Air terminal damper or flow sensor issue. Reported airflow exceeds set point when damper is commanded closed.
RTU-5	VAV summary is missing 11 of the air terminals so sum of system air flow is not readily available.
RTU-5 07 G05 Tech DRNG RTU-5 16 H07 Physics RTU-5 24 H05 Earth Science	Air terminal damper or flow sensor issue. Reported airflow exceeds set point when damper is commanded closed.
RTU-5	Minimum outdoor air flow is driven by fume hood operation of 21,560 cfm (EF-15,16,17,29). The design minimum appears to assume all hoods at maximum flow as the 25,545 cfm value exceeds the design minimum flow of the VAV boxes at 14,640 cfm. The mixed air temperature implies 45% outdoor air is being supplied, which will provide more than the outdoor air required for occupants. The coordination of hood flows and potential turn-down with outdoor air control should be reviewed.
RTU-7	Outdoor air flow station reading is erroneous. It reads more than the total system air flow.
RTU-7 33 A21 Principal RTU-7 39 A07 Reception RTU-7 40 A03 Security Rm	Air terminal damper or flow sensor issue. Reported airflow exceeds set point when damper is commanded closed.
RTU-7	The mixed air and return air temperatures appear to be swapped on the BAS graphic.

*Single Zone Rooftop Air Handlers*



Common spaces are served by single zone rooftop units. All units except the gym are constant volume. The outdoor air damper sets the outdoor air flow. In several units (RTU-6) the outdoor air flow did not change with damper position or shows significant air flow with the damper closed (RTU-9, HV-2), suggesting that attention is needed at the RTU outdoor air damper actuator. The table below summarizes the outdoor air flow fraction from the mixed air temperatures. The supply air flow monitoring stations were not reading. There are no other system air flow measurements. The design air flows from the 2003 schedules are shown for reference.

Single-Zone RTU Outdoor Air Summary						
	RTU-3		RTU-6		RTU-8	
Design Air Flow (2003 schedule)	17,419		14,646		2,400	
OA-T (F)	37.5	40.2	36.3	40.8	36.4	40.6
RA-T (F)	72.2	69.8	67.5	67.7	75.3	69.0
MA-T (F)	51.3	47.0	51.0	51.6	66.3	49.9
Calculated OA fraction from MA-T	43%	77%	53%	60%	23%	67%
Design Min OA flow (2003 Schedule)	1,742		1,465		450	
OA AFMS reading	3,198	11,531	6,578	6,729	982	1,935
OA Damper Position (% open)	5%	36%	5%	100%	55%	96%
OA Flow Condition	Adequate		Needs attention		Adequate	
	RTU-9		Auditorium		HV-1	HV-2
Design Air Flow (2003 schedule)	6,135		NA		17,615	6,891
OA-T (F)	36.4	40.6	36.6	40.4	36.6	40.2
RA-T (F)	67.8	67.9	71.1	71.4	66.8	65.1
MA-T (F)	39.3	40.5	62.7	62.5	51.6	60.3
Calculated OA fraction from MA-T	91%	100%	24%	29%	50%	19%
Design Min OA flow (2003 Schedule)	615		NA		2,018	692
OA AFMS reading	3,654	3,927	NR	NR	NR	1,292
OA Damper Position (% open)	0%	0%	5%	5%	5%	0%
OA Flow Condition	Needs attention		Adequate?		ok?	DPR?

Issues are itemized below.

RTU-3	Mixed air temperature suggests 43% outdoor air when the damper is commanded to only 5% open. Airflow increases with more open damper. Is damper actually closing to 5%?
RTU-3	AFMS wiring is looped around OA damper blade.
RTU-3	Found filter blown out from rack and dirty coil inlet face.
RTU-6	The AFMS and mixed air temperature calculation suggest that the damper position has no effect on the outdoor air. Is damper actuating? Suspect damper is stuck about halfway open.
RTU-6	AFMS wiring is loose and sticks through OA damper opening.
RTU-6	Found filter blown out from rack and dirty coil inlet face.
RTU-8	No issues.
RTU-9	Data suggest that the outdoor dampers are mostly open when commanded closed.
RTU-9	Coil inlet face is dirty.
Auditorium	No design data. Mixed air temperature suggests 24% outdoor air with damper commanded 5% open.
HV-1	Mixed air temperature suggests 50% outdoor air with damper commanded 5% open.
HV-1	Found filter blown out of rack
HV-2	Mixed air temperature and AFMS suggest 19% outdoor air flow with damper commanded closed. Does damper actuate?

**HVAC Review Notes**

Priority	Medium / High
Tag	Unit Ventilator
Location	C & D wing classrooms
Service	Classroom
Make	Snyder General
Outdoor Air	Outdoor louver beneath window controlled by damper
Filters	At bottom inlet Example UV
	
	Example UV filter located in air inlet at bottom of unit
	Typical UV outdoor air louver

**Weston High School**

Unit Ventilator Overview 02/18/2026 10:27:19 AM

Description	Space Temp	Supply Temp	Supply SP	Status	Fan Cmd	Alarm	HW Valve	Damper
Special Ed Tag C10	69.3	68.5	120.0	■	■	■	36.5	0.0
Special Ed Life Skills C11	72.5	103.0	104.0	■	■	■	0.0	0.0
Special Ed Conf C12	70.1	106.3	125.0	■	■	■	0.0	0.0
Work Room C13	69.6	105.7	113.0	■	■	■	0.0	0.0
Special Ed C15	70.3	89.2	99.0	■	■	■	40.0	0.0
Special Ed C09	68.7	142.4	64.0	■	■	■	100.0	0.0
World Language C04	72.0	102.6	120.0	■	■	■	0.0	0.0
World Language C03	71.1	106.4	120.0	■	■	■	0.0	0.0
World Language C02	69.8	64.9	95.0	■	■	■	55.0	0.0
World Language C01	-NR-	-NR-	-NR-	■	■	■	-NR-	-NR-
English D07 East	70.1	77.9	67.0	■	■	■	40.0	0.0
English D07 West	65.0	43.9	67.0	■	■	■	81.6	0.0
English D12	65.0	56.8	120.0	■	■	■	100.0	0.0

**BAS UV Summary**  
Two units off due to low temperature safety.  
Occupancy determined by sensor according to staff.

**Weston High School**

Unit Ventilator Overview 02/19/2026 12:30:00 PM

Description	Space Temp	Supply Temp	Supply SP	Status	Fan Cmd	Alarm	HW Valve	Damper
Special Ed Tag C10	69.2	67.0	120.0	■	■	■	22.1	0.0
Special Ed Life Skills C11	72.8	120.3	110.0	■	■	■	0.0	0.0
Special Ed Conf C12	70.2	114.9	125.0	■	■	■	0.0	0.0
Work Room C13	69.3	108.3	125.0	■	■	■	0.0	0.0
Special Ed C15	69.3	102.2	102.0	■	■	■	90.0	15.0
Special Ed C09	68.8	144.1	64.0	■	■	■	100.0	0.0
World Language C04	71.8	107.5	120.0	■	■	■	100.0	0.0
World Language C03	70.7	115.2	120.0	■	■	■	0.0	0.0
World Language C02	70.9	67.1	80.0	■	■	■	0.0	0.0
World Language C01	-NR-	-NR-	-NR-	■	■	■	-NR-	-NR-
English D07 East	70.1	81.3	67.0	■	■	■	40.0	0.0
English D07 West	65.0	51.4	67.0	■	■	■	43.7	5.0
English D12	69.3	147.5	120.0	■	■	■	100.0	0.0

**Example BAS UV Graphic**  
Fan operating with heat. Outdoor damper closed with no sensed occupancy.

**Special Ed Tag C10**

02/18/2026 10:29:35 AM  
Outside Air Temp 36.7 °F  
Outside Air Humid 53.1 %RH

**Floor plan of BAS controlled UVs**  
Note states C11, C12, C15 occupancy sensors are disabled  
Are fans in pneumatically controlled units still manually controlled like in the Elementary school?

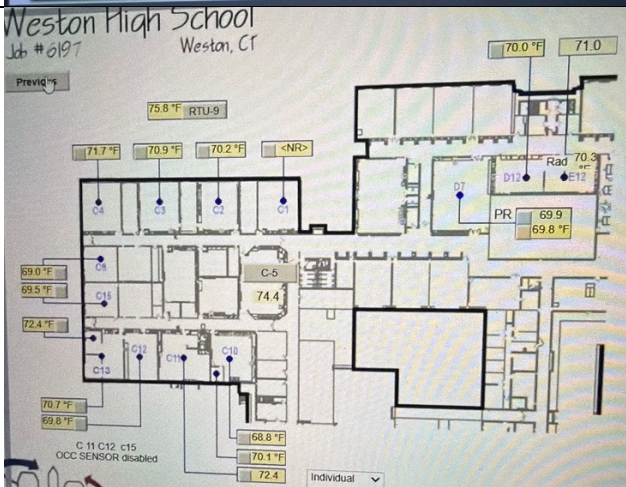

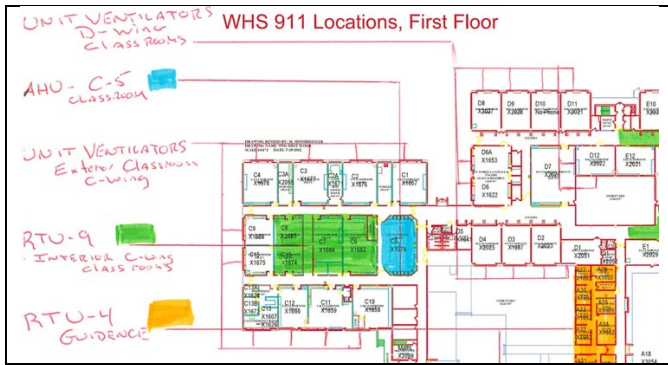



Floor plan showing all UVs



Weston High School Unit Ventilator Inventory

2012 Drawing Room Name	2003 Drawing				
	Room Name	Tag	Airflow (cfm)	Minimum Outdoor Air (cfm)	Outdoor Air Fraction
C10	C08	UV-2	1,500	500	33%
C11	C09	UV-2	1,500	500	33%
C12	C11	UV-1	1,000	450	45%
C13	C12C	existing	500	60	12%
C15	C14	existing	750	300	40%
C9	C16	existing	750	300	40%
C4	C19	existing		450	
C3	C21	existing		450	
C2	C24	existing		450	
C1	C21	existing		450	
D1	E04	existing			
D2	E03	existing			
D3	E02	existing			
D4	E01	existing			
D6	E41	existing			
D6A	E41	existing			
D8	E40	existing			
D9	E39	existing			
D10	E38	existing			
D11	E37	existing			
D7	E44	existing	1,500	420	28%
D7	E44	existing	1,500	420	28%
D12	E38	UV-2	1,500	500	33%
E12	E37	UV-2	1,500	500	33%

Unit Ventilator inventory from 2003 drawings with names from 2012 schematic drawing and BAS labels. 2003 drawings noted to rebalance outdoor air flows on existing UVs to noted values.

**HVAC Review Notes**

Priority	Low
Tag	VRF DOAS
Location	E wing roof
Service	E wing classroom
Make	Venmar CES VHC50
Outdoor Air	100% OA
Filters	None installed on return or supply side of wheel.
	Dedicated outdoor air energy recovery unit
	Return air flow measurement station
	Return air empty filter rack

		<p>Return air inlet to heat recovery wheel</p>
		<p>Outdoor supply empty filter racks</p>
		<p>Outdoor air supply side of heat exchange wheel.</p>



Example VRF using recirculated air to maintain room temperature



Example outdoor air supply vent and exhaust vent in classroom wall adjacent to corridor

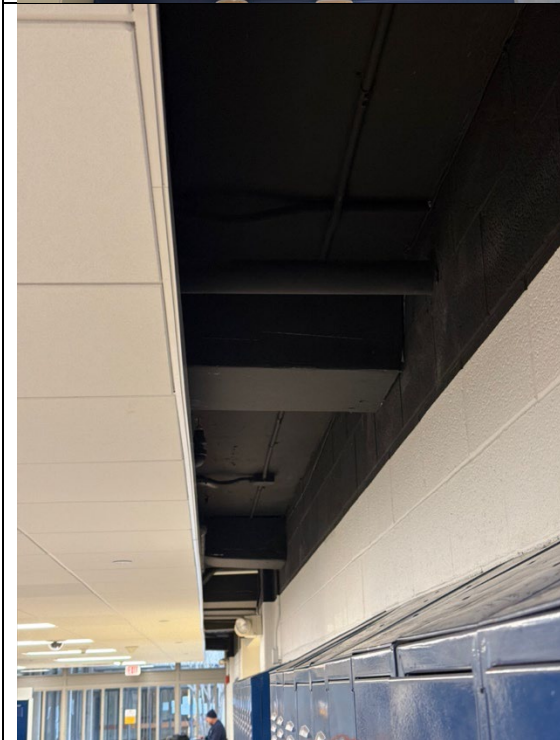

Example take-off duct work to/from corridor mains to each classroom

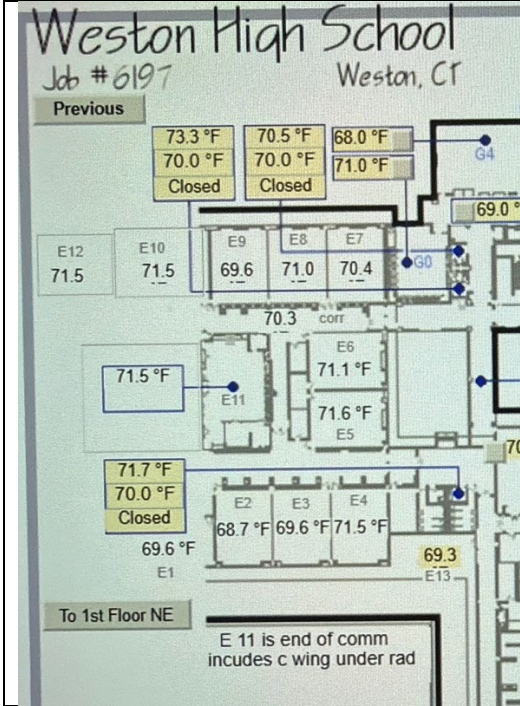

BAS wing E floor plan



2012 schematic floor plan wing E classrooms supplied by rooftop DOAS energy recovery ventilator.

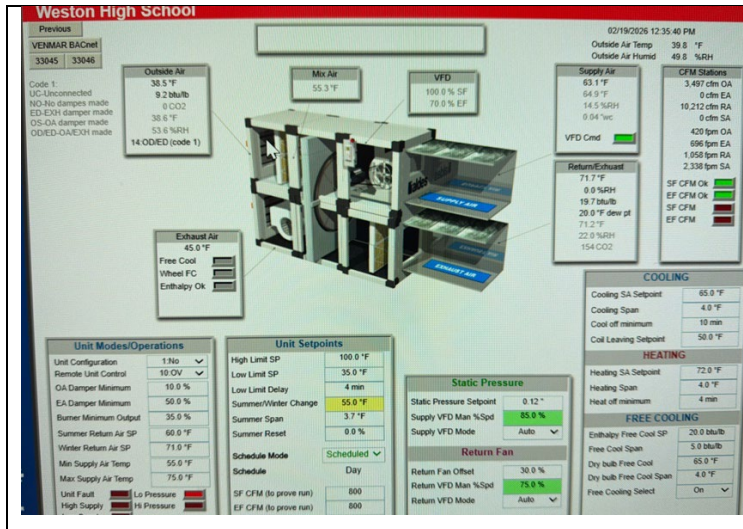

BAS representation of DOAS unit. Display shows air flow velocities in and out of each side of the wheel. Two show a calculated air flow by applying an area to the velocities. It is unclear why an area was not applied to each velocity. The air flows should all be roughly equal. The wheel shows heat recovery raising the 38F outdoor air to 63F before supplying the classrooms by dropping the 72F return air to 45F before being exhausted.

**HVAC Review Notes**

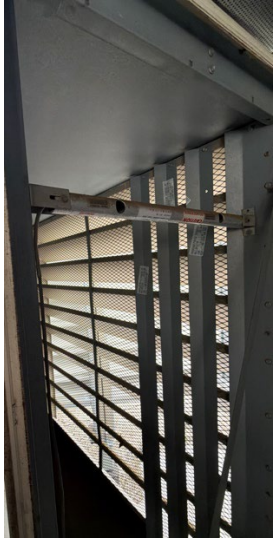
Priority	Medium
Tag	RTU-1
Location	B-wing Roof
Service	B- Wing Music / Art
Type	Multizone VAV
Outdoor Air	AFMS in door with intake louver
Filters	2 inch MERV-8
	Unit Overview
	Outdoor air flow measurement station in door with intake louver.



Mixed air temperature sensor

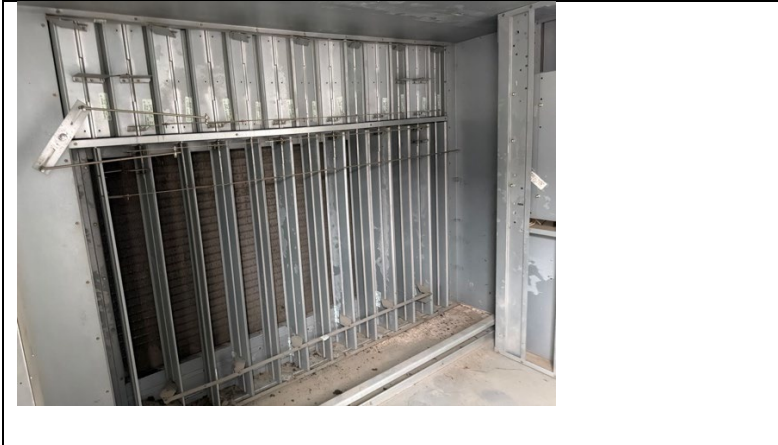

Face and bypass coil dampers



Dirty coil face inlet

**B-Wing Music/Art RTU-1**  
02/18/2026 10:02:23 AM  
Outside Air Temp 36.2 °F  
Outside Air Humid 93.0 %RH

**Econo Dmp**: 20.0%  
-8,065 CFM

**Mixed Air**: 60.3 °F

**Face/Bypass**: 100.0 % Face

**Return VFD**: 54.9 %  
Cmd: [Green]  
Status: [Green]  
Alarm: [Green]

**Supply VFD**: 64.9 %  
Cmd: [Green]  
Status: [Green]  
Alarm: [Green]

**Return Air**: 71.6 °F  
21.5 %RH  
505.0 PPM  
-13,163 CFM

**HW Valve**: 24.7 %

**DX Cooling**:  
Stage-1: [Green]  
Stage-2: [Green]  
Stage-3: [Green]  
Stage-4: [Green]

**Supply Air**: 69.7 °F  
1.79 °WC  
-17,945 CFM

**Unit Status**  
Unit Lockout: Off  
Calculated Discharge SP: 75.7 °F  
Lowest Space Temp: 66.7 °F  
Average Space Temp: 69.4 °F  
Schedule Mode: Scheduled  
Schedule: Day  
Warmup Mode: Off  
Cooldown Mode: Off  
Return Enthalpy: 21.2 Btu/lb  
Outside Enthalpy: 13.1 Btu/lb  
Enthalpy Deadband: 2.0  
Economizer Enable: Off  
Duct Smoke Alarm: [Green]  
Low Limit Alarm: [Green]  
Dirty Filter Alarm: [Green]

**Unit Setpoints**  
Reset DA-T High SP: 90.0  
Reset DA-T Low SP: 50.0  
Reset Avg Spc-T H SP: 72.0  
Reset Avg Spc-T Lo SP: 66.0  
Warmup Supply Air SP: 80.0  
Cooldown Supply Air SP: 55.0  
After Hours Time Limit: 4.0  
Unocc Cdy SP: 74.0  
Unocc Hg SP: 62.0  
Ret Carbon Dioxide SP: 1,100.0

**Static Pressure**  
Static Pressure Setpoint: 1.50  
Supply VFD Man %Spd: 100.0  
Supply VFD Mode: Auto

**Return Fan**  
Return Fan Offset: 10.0  
Return VFD Man %Spd: 0.0  
Return VFD Mode: Auto

**Economizer**  
Minimum Position: 20.0  
Econo Manual Signal: 80.0  
Econo Mode: Auto



**DX Cooling**  
DX Cooling Signal: 0 Stages  
DX OA-T Lockout SP: 60.0

**Face and Bypass Damper**  
Face and Bypass Cmd: 100.0 % Face  
OA-T Enable SP: 20.0  
Control Enabled: Off

**Hot Water Valve**  
Hot Water Valve Cmd: 24.7 % Open  
Heating Manual Signal: 0.0  
Heating Mode: Auto  
Heat OA-T Lockout SP: 55.0  
Heat Night OA-T SP: 40.0  
Heat Night Position: 20.0

RTU-1 B-Wing Music/Art Zone	Minimum Flow 2/18 12:51 pm				Maximum Flow 2/18 1:14 pm			
	Min Stpt	cfm	dpr %	Flow %	Max Stpt	cfm	dpr %	Flow %
49 B Corridor SW	759	331	100	44%	1200	497	100	41%
50 B40 Green Rm	60	293	0	488%	400	349	26	87%
51 B41 Girl's Dressing	130	132	27	102%	450	339	100	75%
52 B39 Boy's Dressing	120	124	0	103%	430	256	48	60%
53 B03 FPA Office/Library	700	689	48	98%	1140	1129	56	99%
54 B04 Music/Practice	600	577	30	96%	1900	1020	96	54%
55 Costime Shop	240	419	0	175%	1000	424	17	42%
56 B10 Music Choral	550	270	100	49%	1000	395	50	40%
57 B11 Music Ensemble	750	742	61	99%	1920	362	16	19%
03 B Corridor NW	900	362	100	40%	1200	689	100	57%
04 B05 Set Const	800	345	100	43%	1100	552	100	50%
05 B Corridor N	500	507	33	101%	1100	973	100	88%
06 B06 Art Class	800	164	100	21%	1220	433	100	35%
07 B07 Graphics Arts	800	561	100	70%	1310	862	74	66%
08 Drawing/Painting Class	800	398	100	50%	1100	667	100	61%
09 B09 3D Art Class	800	477	100	60%	1110	658	100	59%
<b>TOTAL</b>	<b>9309</b>	<b>6391</b>			<b>17580</b>	<b>9605</b>		
Design Air Flow (cfm)						<b>13000</b>		74%
OA-T (F)		37.6				37.1		
RA-T (F)		71.3				70.9		
MA-T (F)		61.7				58.1		
<b>Temp Calc OA Fraction (%)</b>		<b>28%</b>				<b>38%</b>		
<b>Calculated outdoor air (cfm)</b>		<b>1,821</b>				<b>3,637</b>		
BAS AFMS OA (cfm)		-8,190				-7,429		
Design Outdoor Airflow (cfm)		1,305				1,305		
Minimum OA Damper (%)		20%				20%		
Duct Pressure (in wc)		0.25 to 3.5?				0.25 to 3.5?		
Supply Fan Speed (%)		50%				100%		
Retrun Fan Speed (%)		40%				90%		
<b>Notes</b>								
	Supply static pressure is unstable - difficult to control to							
	Flow less than 85% of maximum flow set point with damper open 100%							
	Dampers 100% open suggests SF speed is reset to low in minimum flow case							
	Air flow more than set point with damper closed - flow or damper issue							
	AFMS do not read							
	Sum of air terminal flow is 74% of AHU design flow with SF speed at 100%							
	Outdoor air flow increases with system flow since min damper does not reset							
	Outdoor air flow meets/exceeds design based on mixed air temperature mixing							

**HVAC Review Notes**

Priority	Medium
Tag	RTU-2
Location	A-Wing Roof
Service	A-Wing Media
Type	Multizone VAV
Outdoor Air	AFMS in door with intake louver
Filters	2 inch MERV-8
	Unit overview
	Return fan section
	Outdoor air dampers right Return air dampers left



Outdoor air entry through door louvers. Air flow monitoring station (AFMS) sensors mounted in door



Mixed air temperature sensor mounted 1 foot after filter section



Coil inlet face. Some debris building up especially at bottom

**Weston High School**

Previous  
 VLC Properties  
 Loop Tuning  
 Media

**A-Wing Media Center RTU-2**

02/18/2026 10:04:54 AM  
 Outside Air Temp 36.3 °F  
 Outside Air Humid 93.7 %RH

Econo Dmpr 3.0% 753 CFM  
 Mixed Air 64.8 °F

Return VFD 48.3%  
 Cmd Status Alarm

Supply VFD 58.3%  
 Cmd Status Alarm

Return Air 67.9 °F  
 29.6 %RH  
 388.3 PPM  
 6.575 CFM

HW Valve 0.0%

Supply Air 67.5 °F  
 1.12 °WC  
 1,969 CFM

Unit Status  
 Unit Lockout Off  
 Calculated Discharge SP 67.7 °F  
 Lowest Space Temp 68.2 °F  
 Average Space Temp 69.8 °F  
 Schedule Mode Scheduled  
 Schedule Day  
 Warmup Mode Off  
 Cookdown Mode Off  
 Return Enthalpy 21.2 Btu/lb  
 Outside Enthalpy 13.1 Btu/lb  
 Enthalpy Deadband 0.0  
 Economizer Enable On  
 Duct Smoke Alarm  
 Low Limit Alarm  
 Dirty Filter Alarm

Unit Setpoints  
 Reset DA-T High SP 90.0  
 Reset DA-T Low SP 65.0  
 Reset Avg Spc-T H SP 70.0  
 Reset Avg Spc-T Lo SP 68.0  
 Warmup Supply Air SP 90.0  
 Cookdown Supply Air SP 55.0  
 Alter Hours Time Limit 6.0  
 Unocc Cig SP 74.0  
 Unocc Htg SP 68.0  
 Ret Carbon Dioxide SP 1,100.0

Economizer  
 Minimum Position 5.0  
 Econo Manual Signal 5.0  
 Econo Mode Auto

Static Pressure  
 Static Pressure Setpoint 1.10  
 Supply VFD Man %Spd 100.0  
 Supply VFD Mode Auto



Return Fan  
 Return Fan Offset 10.0  
 Return VFD Man %Spd 0.0  
 Return VFD Mode Auto

DX Cooling  
 DX Cooling Signal 0 Stages  
 DX OA-T Lockout SP 60.0

Hot Water Valve  
 Hot Water Valve Cmd 0.0% Opn  
 Heating Manual Signal 5.0  
 Heating Mode Auto  
 Heat DA-T Lockout SP 55.0  
 Heat Night OA-T SP 50.0  
 Heat Night Position 65.0

RTU-2 A-Wing Media Zone	Minimum Flow 2/18 12:12 pm				Maximum Flow 2/18 11:08 am			
	Min Stpt	cfm	dpr %	Flow %	Max Stpt	cfm	DPR	Flow %
03 H04 Athletic Dir	200	209	35	105%	900	526	100	58%
04 A04 Class	600	598	40	100%	1500	1010	100	67%
06 A02 Class	200	199	48	100%	1400	250	100	18%
07 Media Center	360	388	25	108%	1200	1204	72	100%
08 Small Group S	500	152	100	30%	1200	153	100	13%
09 Media Center SW	630	620	29	98%	2100	1544	100	74%
10 Media Center	350	333	30	95%	1155	1146	65	99%
11 Media Center	480	468	24	98%	1600	1547	100	97%
14 Media Center Office	50	64	0	128%	75	79	15	105%
15 Media Center	350	390	35	111%	1155	1133	64	98%
16 Media Center	480	507	0	106%	1600	1479	100	92%
17 Media Center	230	224	42	97%	770	684	100	89%
18 Media Center	360	564	0	157%	1200	1205	59	100%
19 Periodicals	390	423	26	108%	800	803	53	100%
20 Small Group N	150	154	0	103%	600	201	100	34%
21 Media Center NW	630	617	23	98%	2100	1898	100	90%
22 Display/Lobby S	270	272	70	101%	650	319	100	49%
23 Display/Lobby N	295	347	0	118%	975	925	100	95%
24 Workroom	145	164	0	113%	475	475	83	100%
25 IMC/Copy	405	352	100	87%	595	341	100	57%
26 A01 Computer Class	600	564	29	94%	1200	1192	59	99%
27 Comp Class Office	600	308	100	51%	1000	296	100	30%
<b>TOTAL</b>	<b>8275</b>	<b>7917</b>			<b>24250</b>	<b>18410</b>		
Design Air Flow						<b>21400</b>		86%
OA-T (F)		36.2				37.3		
RA-T (F)		67.6				68.4		
MA-T (F)		58.7				54.2		
<b>Temp Calc OA Fraction (%)</b>		<b>28%</b>				<b>46%</b>		
<b>Calculated outdoor air (cfm)</b>		<b>2,244</b>				<b>8,406</b>		
BAS AFMS OA (cfm)		1,593				5,518		
Design Outdoor Airflow (cfm)		2,140				2,140		
Minimum OA Damper (%)		15%				15%		
Duct Pressure (in wc)		1.11				0.95		
Supply Fan Speed (%)		52%				95%		
Retrun Fan Speed (%)		42%				85%		
<b>Notes</b>								
		Flow less than 85% of maximum flow set point with damper open 100%						
		Dampers 100% open suggests SF speed is reset to low in minimum flow case						
		Air flow mopre than set point with damper closed - flow or damper issue						
		Sum of air terminal flow is 86% of AHU design flow with SF speed at 95%						
		Outdoor air flow increases with system flow sine min damper does not reset						
		Outdoor air flow meets/exceeds design based on mixed air temperature mixing						

**HVAC Review Notes**

Priority	Medium
Tag	RTU-4
Location	D-Wing Roof
Service	D-Wing Counseling
Type	Multizone VAV
Outdoor Air	Outdoor dampers at top of mixing chamber
Filters	2 inch MERV-8
	Unit overview
	Outdoor air damper top Return air damper bottom



Mixed air temperature sensor mounted directly behind filter at coil inlet

**Weston High School**

Previous | VLC Properties | Loop Tuning

**D-Wing Counseling RTU-4** 02/18/2026 10:08:25 AM  
Outside Air Temp 36.3 °F  
Outside Air Humid 93.7 %

Econo Dmpir: 5.0 %  
 451 CFM  
 Mixed Air: 66.0 °F

Power Exh Cmd:    
 exhaust comes on when oa damper is above power exhaust enable sp

Return Air: 67.1 °F  
 25.0 %RH  
 590.9 PPM

Supply VFD: 100.0 %  
 Cmd:    
 Status:    
 Alarm:

Supply Air: 69.0 °F  
 1.27 °WC  
 5,633 CFM

DX Cooling: Stage-1  Stage-2

Max Static: 1.60  
 Min Static: 1.00  
 Highest Damper Position: 100.0



Unit Status	
Unit Lockout	Off
Calculated Discharge SP	80.7 °F
Lowest Space Temp	66.2 °F
Average Space Temp	70.1 °F
# Of Heat Callers	1.0 #
# Of Cool Callers	0.0 #
Schedule Mode	Scheduled
Schedule	Day
Warmup Mode	Off
Cooldown Mode	Off
Return Enthalpy	20.1 Btu/lbs
Outside Enthalpy	13.1 Btu/lbs
Enthalpy Deadband	1.0
Economizer Enable	On
Duct Smoke Alarm	<input type="checkbox"/>
Daily Filter Alarm	<input type="checkbox"/>

Unit Setpoints	
Reset DA-T High SP	85.0
Reset DA-T Low SP	70.0
Reset Avg Spc-T Hl SP	73.0
Reset Avg Spc-T Lo SP	69.0
Cooldown Supply Air SP	56.0
Alter Hours Time Limit	4.0
Unocc Ctg SP	72.0
Unocc Htg SP	68.0
Ret Carbon Dioxide SP	1,100.0
Power Exh Enable SP	85.0

Static Pressure	
Static Pressure Setpoint	1.60
Supply VFD Man %Spd	50.0
Supply VFD Mode	Auto
DX Cooling	
DX Cooling Signal	0 Stages
DX OA-T Lockout SP	60.0
Callers To Allow DX Cool	1.0
Economizer	
Minimum Position	5.0
Econo Manual Signal	0.0
Econo Mode	Auto

RTU-4 D-Wing Counseling Zone	Minimum Flow 2/18 1:53 pm				Maximum Flow 2/18 1:27 pm			
	Min Stpt	cfm	dpr %	Flow %	Max Stpt	cfm	DPR	Flow %
42 A30 Break Rm	165	167	0	101%	605	454	100	75%
43 A34 Conference Rm	225	229	31	102%	400	396	100	99%
44 A35 Office	200	199	15	100%	500	373	100	75%
45 A32 Office	250	252	30	101%	700	333	100	48%
46 A29 Office	200	691	0	346%	600	622	0	104%
47 Career Center	575	523	80	91%	900	915	81	102%
48 B01 Class	270	295	4	109%	1020	936	100	92%
<b>TOTAL</b>	<b>1885</b>	<b>2356</b>			<b>4725</b>	<b>4029</b>		
Design Air Flow						<b>6400</b>		63%
OA-T (F)	39				38.2			
RA-T (F)	68.2				67			
MA-T (F)	66.4				66.5			
Temp Calc OA Fraction (%)	6%				2%			
Calculated outdoor air (cfm)	145				70			
BAS AFMS OA (cfm)	387				750			
Design Outdoor Airflow (cfm)	1,305				1,305			
Minimum OA Damper (%)	10%				10%			
Duct Pressure (in wc)	1.13				0.69			
Supply Fan Speed (%)	88%				100%			
Retrun Fan Speed (%)	NA				NA			
<b>Notes</b>								
	Flow less than 85% of maximum flow set point with damper open 100%							
	Air flow mopre than set point with damper closed - flow or damper issue							
	Sum of air terminal flow is 63% of AHU design flow with SF speed at 100%. Sum of maximum terminal air flows is less than the RTU design flow suggesting changes since the 2003 design?							
	Mixed temperature outdoor air flow calcaultion shows very little outdoor air being introduced possibly due to the small mixing area in the RTU not allowing the temperature sesnor to represent the mixed conditons. The BAS air flow measurement increases with fan speed as expected, although still below design.							

**HVAC Review Notes**

Priority	Medium
Tag	RTU-5
Location	Science Roof
Service	Science
Type	Multizone VAV
Outdoor Air	AFMS in door with intake louver
Filters	4 inch MERV 8
	Unit Overview
	Return fan section EBTRON AFMS transducer
	Outdoor air damper next to return damper



Outdoor AFMS sensors in door after inlet louvers



Filter section – 4 inch deep MERV 8 filters



 A screenshot of a BMS interface for a unit labeled "H/G-Wing Science RTU-5". The interface displays various operational parameters and controls. At the top right, it shows the date and time: "02/18/2025 10:09:35 AM". Below this, it shows "Outside Air Temp 36.2 °F" and "Outside Air Humid 63.7 %RH". The interface is divided into several sections:
 

- Unit Status:** Shows "Unit Lockout" (Off), "Calculated Discharge SP" (70.1 °F), "Lowest Space Temp" (67.8 °F), and "Average Space Temp" (70.3 °F).
- Unit Setpoints:** Lists various setpoints such as "Reset DA-T High SP" (90.0), "Reset DA-T Low SP" (55.0), "Reset Avg Spec-T Hl SP" (72.0), "Reset Avg Spec-T Lo SP" (68.0), "Warmup Supply Air SP" (90.0), "Cooldown Supply Air SP" (55.0), "After Hours Time Limit" (4.0), "Unocc Cdg SP" (70.0), and "Unocc Hly SP" (59.5).
- Face and Bypass Damper:** Shows "Face and Bypass Cmd" (27.4 % Face), "OA-T Enable SP" (50.0), and "Control Enabled" (On).
- Static Pressure:** Shows "Static Pressure Setpoint" (0.70), "Supply VFD Man %Spd" (50.0), and "Supply VFD Mode" (Auto).
- Return Fan:** Shows "Return Fan Offset" (14.0), "Return VFD Man %Spd" (75.0), and "Return VFD Mode" (Auto).
- DX Cooling:** Shows "Stage-1" through "Stage-6" with various status indicators.
- Economizer:** Shows "Occupied Min Position" (5.0), "Unoccupied Min Position" (5.0), "Econo Manual Signal" (0.0), and "Econo Mode" (Auto).
- Hot Water Valve:** Shows "Hot Water Valve Cmd" (27.4 % Opm), "Heating Manual Signal" (0.0), "Heating Mode" (Auto), "Heat OA-T Lockout SP" (65.0), "Heat Night OA-T SP" (40.0), and "Heat Night Position" (75.0).

H/G-Wing Science RTU-5

RTU-5 Science Zone	Minimum Flow 2/18 2:15 pm				Maximum Flow 2/18 2:27 pm				Drawings		
	Min Stpt	cfm	dpr %	Flow %	Max Stpt	cfm	DPR	Flow %	min	max	
01 G00 IT Small Lab	370	372	53	101%	1700	427	100	25%	630	2100	
02 G Corridor	1200	1206	75	101%	1800	1224	100	68%	710	2400	
04 G04 IT Large Lab	1045	452	100	43%	3200	449	100	14%	1045	3480	
05 K27 Small Projects	240	229	100	95%	800	228	100	29%	240	800	
06 G01 Staff RSRC	650	370	100	57%	2160	373	100	17%	650	2160	
07 G05 Tech DRNG	265	805	0	304%	720	820	0	114%	675	2240	
08 K24 Student Research			100				100		450	1025	
06 G6 Computer Lab N	810	333	100	41%	2680	333	100	12%	810	2680	
10 G06 computer Lab S	435	346	100	80%	1440	338	100	23%	660	2490	
11 G2 Science Lab			50				50		660	2470	
12 K22 Lab Prep			50				50		225	740	
13 G03 Science Lab			50				50		660	2470	
14 K17 Prep/Work			50				50		435	1440	
15 G07 it/Science			100				100		660	2490	
16 H07 Physics	740	1001	0	135%	2300	1620	53	70%	640	2300	
17 K34 Lab Prep	220	82	100	37%	720	83	100	12%	220	720	
18 H03 Chemistry			100				100		660	2370	
19 K38 Lab Prep			50				50		240	735	
20 H02 Chemistry			100				100		660	2360	
21 H06 Physics	690	658	88	95%	2000	1968	87	98%	640	2300	
24 H05 Earth Science	290	569	0	196%	2300	1470	52	64%	640	2300	
25 H01 Chemistry			50				50		660	2360	
26 K41 Lab Prep			100				100		240	740	
27 K30 Lab Prep	690	505	100	73%	2300	405	100	18%	190	630	
28 H04 Earth Science	500	273	100	55%	1100	273	100	25%	640	2300	
29 H Corridor	1400	761	100	54%	2160	761	100	35%	690	2160	
<b>TOTAL</b>	<b>9545</b>	<b>7962</b>			<b>27380</b>	<b>10772</b>			<b>14630</b>	<b>50260</b>	
Design Air Flow						<b>42825</b>		25%			
OA-T (F)		39				39.1					
RA-T (F)		71.2				71.1					
MA-T (F)		56.8				56.9					
Temp Calc OA Fraction (%)		<b>45%</b>				<b>44%</b>					
Calculated outdoor air (cfm)	Incomplete terminal summary				Incomplete terminal summary						
BAS AFMS OA (cfm)		14,406				15,765					
Design Outdoor Airflow (cfm)		25,545				25,545			More than min?		
Minimum OA Damper (%)		10%				10%					
Duct Pressure (in wc)		0.69				0.64					
Supply Fan Speed (%)		65%				<b>73%</b>					
Retrun Fan Speed (%)		51%				59%					
Notes											
	Sum of design minimum air flows are greater than the minimum outdoor air. The sum of the fume hood maximum exhaust is 22,000 cfm										
	Flow less than 85% of maximum flow set point with damper open 100% - More time needed to allow SF to ramp to full speed										
	Dampers 100% open suggests SF speed is reset to low in minimum flow case										
	Air flow more than set point with damper closed - flow or damper issue										
	VAV Summary is incomplete so total flow cannot be estimated										

**HVAC Review Notes**

Priority	Medium
Tag	RTU-7
Location	Roof
Service	Admin Offices
Type	Multizone VAV
Outdoor Air	Packing material at OA inlet screen has blown out
Filters	2 inch MERV-8
	Unit overview
	Inlet screen fill has broken loose – top Relief dampers – bottom (powered exhaust fan behind dampers)



Mixed air section

**Weston High School**

02/19/2026 10:13:16 AM  
Outside Air Temp 36.4 °F  
Outside Air Humid 93.8 %RH

**A-Wing Admin Office RTU-7**

Previous  
VLC Properties  
Loop Tuning

Econo Dmper: 20.5 %  
12,042 CFM

Mixed Air: 64.8 °F

Supply VFD: 87.7 %  
Cmd Status Alarm

Supply Air: 65.0 °F  
0.96 °WC  
737 CFM

Return Air: 60.4 °F  
40.6 %RH  
1,028.3 FPM

Unit Status

Unit Lockout	Off
Calculated Discharge SP	65.0 °F
Lowest Space Temp	69.5 °F
Average Space Temp	71.2 °F
# Of Heat Callers	1.0 #
# Of Cool Callers	3.0 #

Schedule Mode: Force Day

Unit Setpoints

Reset DA-T High SP	75.0
Reset DA-T Low SP	65.0
Reset Avg Spc-T Hl SP	70.0
Reset Avg Spc-T Lo SP	68.0
Cooldown Supply Air SP	55.0
After Hours Time Limit	4.0
Unsecc Clp SP	75.0
Unsecc Hg SP	62.0
Ret Carbon Dioxide SP	1,100.0
Power Exh Enable SP	30.0

Static Pressure

Static Pressure Setpoint	1.00
Supply VFD Man %Spd	85.0
Supply VFD Mode	Auto

DX Cooling



DX Cooling Signal	0 Stages
DX OA-T Lockout SP	60.0
Callers To Allow DX Cool	1.0

Economizer

Minimum Position	5.0
Econo Manual Signal	0.0
Econo Mode	Auto

RTU-7 Admin Office Zone	Minimum Flow 2/20 8:58 am				Maximum Flow 2/20 9:03 am			
	Min Stpt	cfm	dpr %	Flow %	Max Stpt	cfm	DPR	Flow %
31 A30 Waiting	120	118	26	98%	300	216	81	72%
32 A28! Medical Suite	240	236	48	98%	400	310	100	78%
33 A21 Principal	75	217	0	289%	880	765	57	87%
34 A16 Assistant Principal	275	264	8	96%	800	818	62	102%
35 A09 Conference S	500	551	25	110%	1500	1291	65	86%
36 A17 Principal Secretary	150	154	16	103%	500	377	71	75%
37 A10 General Office	750	661	100	88%	1500	483	100	32%
38 A12 Office	350	89	100	25%	1000	81	100	8%
37 A09 Conference N	800	814	33	102%	1500	1544	62	103%
38 A06 Assistant Principal	225	234	1	104%	800	497	59	62%
39 A07 Reception	90	114	0	127%	250	243	29	97%
40 A03 Security Rm	140	197	0	141%	500	234	56	47%
<b>TOTAL</b>	<b>3715</b>	<b>3649</b>			<b>9930</b>	<b>6859</b>		
Design Air Flow						<b>8200</b>		84%
OA-T (F)	35.7				35.9			
RA-T (F)	64.8				66.5			
MA-T (F)	60.5				58.1			
Temp Calc OA Fraction (%)	15%				27%			
Calculated outdoor air (cfm)	539				1,883			
BAS AFMS OA (cfm)	6,186				8,013			
Design Outdoor Airflow (cfm)	1,311				1,311			
Minimum OADamper (%)	9%				9%			
Duct Pressure (in wc)	0.97				0.49			
Supply Fan Speed (%)	77%				96%			
Retrun Fan Speed (%)	NA				NA			
<b>Notes</b>								
	Flow less than 85% of maximum flow set point with damper open 100%. More time needed for dampers to open - testing had to be suspended							
	Dampers 100% open suggests appears to be airflow/damper issue							
	Air flow more than set point with damper closed - flow or damper issue							
	AFMS do not read correctly							
	Sum of air terminal flow is 84% of AHU design flow with SF speed at 96%							
	Outdoor air flow increases with system flow sine min damper does not reset							
	Outdoor air flow is below design a t low system flow. Min OA damper needs to be increased or reset with lower supply fan speed based on mixed air temperature mixing							
	MA-T and RA-T are appear swapped on graphic							

**HVAC Review Notes**

Priority	Medium
Tag	RTU-3
Location	H-wing Roof
Service	Cafeteria
Type	Single Zone Constant Volume RTU
Outdoor Air Filters	AFMS in door with intake louver 2 inch MERV-8. Filter blown out of rack.
	Unit Overview
 	Found filter blown out of rack and dirty coil inlet face



OA damper right – wire wrapped around bottom of blade  
Return dampers left



Outdoor air flow measuring station (AFMS) in door with intake louvers

**Weston High School**

H-Wing Cafeteria RTU-3

03/18/2025 10:07:26 AM  
Outside Air Temp 35.2 °F  
Outside Air Humid 93.3 %RH

Return Fan: Cmd Status Alarm  
Econo Dmpt: 7.3% 4,201 CFM  
Mixed Air: 91.3 °F

Return Air: 67.7 °F 28.4 %RH 430.4 FPM 437 CFM

Kitchen Hood Status: Mode Scheduled on 4:00am off 4:00pm  
EF-2 Status  
Unit Status: Off

Unit Setpoints:  
Occupied Space SP: 69.0  
Cooling Offset SP: 1.0  
Heating Offset SP: 1.0  
Max Discharge Air SP: 110.0  
Min Discharge Air SP: 50.0  
Warmup Supply Air SP: 85.0  
Cooldown Supply Air SP: 50.0  
After Hours Time Limit: 74.0  
Unocc Ctg SP: 60.0  
Unocc Htg SP: 1,100.0  
Rat Carbon Dioxide SP: 55.0  
Dehumidification SP: 55.0



DX Cooling: Stage-1 Stage-2 Stage-3 Stage-4 Stage-5  
Space: 68.0 °F  
OA To Heat Stage 1: 75.0

Supply Fan: Cmd Status Alarm  
Supply Air: 68.0 °F -11,141 CFM Calculated 68.0 °F  
Cafeteria H01 Radiation: 68.0 °F Closed

Hot Water Valve: HW Valve Manual Signal: 100.0 HW Valve Mode: Auto Heat OA-T Lockout SP: 60.0 Heat Night OA-T SP: 60.0 Heat Night Position: 50.0

Economizer: Minimum Position: 5 DX Cooling Signal: 0.0 Stages: 4.0 DX OA-T Lockout SP: 50.0 Econo Manual Signal: 50.0 Econo Mode: Auto

**HVAC Review Notes**

Priority	Medium
Tag	RTU-6
Location	H-wing Roof
Service	Gallery
Type	Single Zone Constant Volume RTU
Outdoor Air Filters	AFMS in door with intake louver 2 inch MERV-8. Two filters blown out of rack.
	Outdoor air flow measurement station in door with intake louvers. OA dampers right. Return air dampers left.
	Outdoor air damper – filter blown out behind damper. Wiring is looped through damper blades.



Dirty coil inlet face. Filter blown out.

**Weston High School**

Previous  
VLC Properties  
Loop Tuning

**J-Wing Locker Rm / Corridor RTU-6**

02/18/2026 10:11:24 AM  
Outside Air Temp 36.3 °F  
Outside Air Humid 93.8 %RH

Econo Drain 5.0%  
Mixed Air 51.0 °F

Return Fan  
Cmd Status Alarm

Supply Fan  
Cmd Status Alarm

Return Air  
67.5 °F  
-4.3 %RH  
0.0 PPM  
252 CFM

Supply Air  
63.3 °F  
-15,273 CFM

HW Valve 100.0 %

DX Cooling  
Stage 1  
Stage 2  
Stage 3  
Stage 4

Space 67.6 °F

Unit Status  
Unit Lockout Off  
Calculated Discharge SP 95.0 °F  
Current Cooling SP 79.0 °F  
Current Heating SP 68.0 °F  
Schedule Mode Force Day  
Schedule Day  
Warmup Mode Off  
Cooldown Mode Off  
Dehumidification Mode Off  
Return Enthalpy 15.5 Btu/lbs  
Outside Enthalpy 13.2 Btu/lbs  
Enthalpy Deadband 1.0  
Economizer Enable On  
Duct Smoke Alarm  
Low Limit Alarm  
Dirty Filter Alarm

Unit Setpoints  
Occupied Space SP 69.0  
Cooling Offset SP 1.0  
Heating Offset SP 1.0  
Max Discharge Air SP 95.0  
Min Discharge Air SP 55.0  
Warmup Supply Air SP 125.0  
Cooldown Supply Air SP 50.0  
After Hours Time Limit 4.0  
Linocx Ctg SP 76.0  
Linocx Htg SP 62.0  
Ret Carbon Dioxide SP 1,500.0  
Dehumidification SP 50.0



DX Cooling  
DX Cooling Signal 0.0 Stages  
DX OA-T Lockout SP 50.0

Economizer  
Minimum Position 5.0  
Econo Manual Signal 50.0  
Econo Mode Auto

Hot Water Valve  
HW Valve Manual Signal 100.0  
HW Valve Mode Auto  
Heat OA-T Lockout SP 70.0  
Heat Night OA-T SP 65.0  
Heat Night Position 50.0

HW Coil located in Supply Duct.

**HVAC Review Notes**

Priority	Medium
Tag	RTU-8
Location	A-wing Roof
Service	Computer
Type	Single Zone Constant Volume RTU
Outdoor Air	Damper at top of mixing chamber
Filters	2 inch Merv-8
	Unit overview
	Outdoor damper on slant at top. Return air damper on slant at bottom



Mixed air temperature sensor in gap between filters and coil

**TV Studio A03 RTU-8**  
02/18/2026 10:14:46 AM  
Outside Air Temp 36.4 °F  
Outside Air Humid 93.5 %RH

**Econo Depr:** 55.0%  
982 CFM

**Mixed Air:** 68.3 °F

**Space:** 71.6 °F

**Supply Fan:** 1,702 CFM

**Supply Air:** 78.9 °F

**DX Cooling:** Stage-1, Stage-2

**Heating Valve:** 0.0%

**Unit Status:** Heated from brm2

**Unit Setpoints:**

Disc Space Set Point	78.0
High Offset	1.0
Cooling Offset SP	1.0
2nd Stage Cooling Offset	1.5
After Hours Time Limit	4.0
Unocc Cig SP	72.0
Rel Carbon Dioxide SP	550.0
DX OA-T Lockout SP	50.0
Supply Air Low Limit SP	40.0

**Economizer:**

Econo Supply Temp SP	15.0
Minimum Position	5.0
Econo Manual Signal	0.0
Econo Mode	Auto

**Heating:**

OA Heating Enable SP	60.0
Manual Valve Mode	Auto
Manual SP	100.0

**Line Status:**

Line Lockout	Off
Current Heating SP	69.0 °F
Current Cooling SP	71.0 °F
2nd Stage Cooling SP	72.5 °F

**Schedule Mode:** Force Day

**Schedule:** Day

**Return Enthalpy:** 22.9 Btu/lb

**Outside Enthalpy:** 33.1 Btu/lb

**Enthalpy Deadband:** 2.0

**Economizer Enable:** On

**Duct Smoke Alarm:** [Status]



**Freeze Stat Status:** [Status]

**Low Supply Limit Alarm:** [Status]

**Hot Water System Available:** [Status]

**Heating Valve OA Enabled:** [Status]

**HVAC Review Notes**

Priority	Medium
Tag	RTU-9
Location	C-wing Roof
Service	C-wing Interior Classrooms
Type	Single Zone Constant Volume RTU
Outdoor Air	One damper open, actuator connected?
Filters	2 inch MERV-8
	Unit Overview
	Dirty coil inlet face. Mixed air temperature across bottom of coil.



Damper is open when unit is off.  
Is actuator connected to closed damper? It is at an odd angle.



AFMS outside under shroud.  
Damper did not close when unit was off,



**Weston High School**  
C-Wing Classrooms RTU-9  
02/18/2026 10:16:38 AM  
Outside Air Temp 36.4 °F  
Outside Air Humid 93.7 %RH

**Econo Dmpg**  
0.0 %  
3,654 CFM

**Mixed Air**  
39.3 °F

**Return VFD**  
Cmd:   
Status:   
Alarm:

**Supply VFD**  
Cmd:   
Status:   
Alarm:

**Return Air**  
67.2 °F  
101.4 %RH  
591.0 PPM  
1,414 CFM

**Supply Air**  
66.1 °F  
37 CFM

**HW Valve**  
28.0 %

**Room C9 Space**  
74.7 °F

**Unit Status**  
Unit Lockout:  Off  
Calculated Discharge SP: 65.0 °F  
Lowest Space Temp: 70.2 °F  
Average Space Temp: 72.1 °F  
Current Cooling SP: 70.0 °F  
Current Heating SP: 68.0 °F  
Schedule Mode: Force Day  
Schedule: Day  
Warmup Mode: Off  
Cooldown Mode: On  
Return Enthalpy: 33.0 Btu/lb  
Outside Enthalpy: 13.2 Btu/lb  
Enthalpy Deadband: 2.0  
Economizer Enable:  On  
Duct Smoke Alarm:   
Low Limit Alarm:   
Dirty Filter Alarm:

**Unit Setpoints**

Occupied Space SP	69.0
Cooling Offset SP	1.0
Heating Offset SP	1.0
Max Discharge Air SP	80.0
Min Discharge Air SP	55.0
Warmup Supply Air SP	100.0
Cooldown Supply Air SP	55.0
After Hours Time Limit	4.0
Unocc. Cig SP	75.0
Unocc. Htg SP	62.0
Ret. Carbon Dioxide SP	950.0

**Economizer**  
Minimum Position: 5  
Econo Manual Signal: 0.0  
Econo Mode: Auto

**Hot Water Valve**  
HW Valve Manual Signal: 100.0  
HW Valve Mode: Auto  
Heat OA-T Lockout SP: 60.0  
Heat Night OA-T SP: 80.0  
Heat Night Position: 50.0



**Notes:**  
\*\*Lowest Space Temp\*\* is what triggers call for Warmup/Cooldown Mode, referencing Unocc. Htg/Cig SP

**HVAC Review Notes**

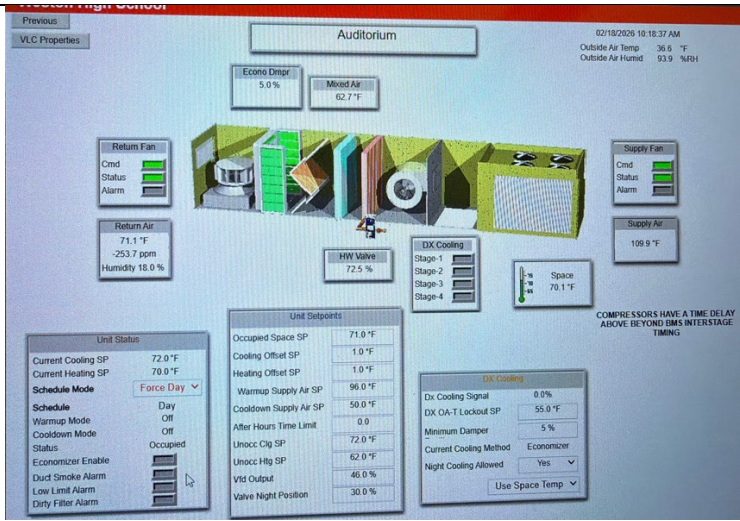
Priority	Medium
Tag	Auditorium
Location	Auditorium Catwalk – did not access
Service	Auditorium
Type	Single Zone Constant Volume RTU
Outdoor Air	
Filters	



**HVAC Review Notes**

Priority	Medium
Tag	HV-1
Location	Roof
Service	Gym
Type	Single Zone VAV RTU
Outdoor Air	AFMS in door with intake louver
Filters	2 inch Merv-8. One found blown out
	Unit Overview
	Outdoor air damper – right Return air damper - left



Outdoor air AFMS in door with intake louver.



Significant debris on outdoor air flow sensor element.



Lower center filter blown out



Mixed air temperature sensor and dirty coil inlet face

 A screenshot of a BACnet-based HVAC control interface for Weston High School. The interface displays various system parameters and controls for the HV-1 New Gymnasium.
 

**Weston High School**  
HV-1 New Gymnasium

02/19/2026 10:19:58 AM  
Outside Air Temp 36.6 °F  
Outside Air Humid 93.8 %RH

**Econo Dmpr:** 5.0 %  
**Mixed Air:** 51.6 °F

**Return VFD:** 65.0 %  
Cmd: [OK]  
Status: [OK]  
Alarm: [OK]

**Return Air:** 66.8 °F  
4,936 CFM  
Space Temp: 67.6 °F

**HW Valve:** 46.2 %

**Supply VFD:** 75.0 %  
Cmd: [OK]  
Status: [OK]  
Alarm: [OK]

**Supply Air:** 70.1 °F  
-21 CFM

**Unit Status:**  
Unit Lockout: Off  
Calculated Discharge SP: 75.1 °F  
Current Cooling SP: 66.0 °F  
Current Heating SP: 67.6 °F  
Occ. Sensor Status: Unoccupied  
Schedule Mode: Force Day  
Schedule: Day  
Warmup Mode: Off  
Cooldown Mode: Off  
Outside Entahpy: 13.3 Btu/lb  
Economizer Enable: Off  
Duct Smoke Alarm: Off  
Low Limit Alarm: Off  
Dirty Filter Alarm: Off

**Unit Setpoints:**  
Occupied Space SP: 68.0  
Cooling Offset SP: 1.0  
Heating Offset SP: 1.0  
Max Discharge Air SP: 85.0  
Min Discharge Air SP: 52.0  
Warmup Supply Air SP: 75.0  
Cooldown Supply Air SP: 50.0  
After Hours Time Limit: 4.0  
Unocc. Cig SP: 75.0  
Unocc. Htg SP: 62.0  
Standby Fan Offset: 50.0  
Sp. Carbon Dioxide SP: 1,800.0

**Economizer:**  
OA-T Enthlpy SP: 19.0  
Minimum Position: 5.0

**Supply Fan:**  
Max VFD Speed Reset: 100.0  
Min VFD Speed Reset: 75.0  
Supply VFD Man %Spd: 0.0  
Supply VFD Mode: Auto



**Return Fan:**  
Return Fan Offset: 10  
Return VFD Man %Spd: 50.0  
Return VFD Mode: Auto

**DX Cooling:**  
Stage-1: [On]  
Stage-2: [Off]  
Stage-3: [Off]  
Stage-4: [Off]  
Low Limit Shutdown: [Off]  
Econo Manual Signal: 10.0  
Econo Mode: Auto

**Hot Water Valve:**  
DX Cooling Signal: 0 Stages  
DX OA-T Lockout SP: 50.0  
Hot Water Valve Cmd: 48.2 % Open  
Heating Manual Signal: 40.0  
Heating Mode: Auto  
Heat OA-T Lockout SP: 60.0  
Heat Night OA-T SP: 50.0  
Heat Night Position: 65.0

Weston High School HVAC control interface showing various system parameters and controls.

**HVAC Review Notes**

Priority	Medium
Tag	HV-2
Location	F-wing Roof
Service	F-wing Lockers
Type	Single Zone Constant Volume RTU
Outdoor Air	AFMS behind louvers in front of dampers
Filters	2-inch MERV-8
	Unit Overview
	Return damper - near. Outdoor damper far through RA damper.



Outdoor air flow measurement station behind bird screen in front of damper



Mixed air temperature sensor at filter outlet.

**Weston High School**

F-Wing Locker Rm HV-2

02/18/2025 10:20:45 AM  
Outside Air Temp 35.6 °F  
Outside Air Humid 93.8 %RH

Previous  
VLC Properties  
Loop Tuning

Econo Drip: 0.0%  
Mixed Air: 71.9 °F

Return Fan: Cmd Status Alarm  
Return Air: 67.9 °F, 586.7 PPM, 1,013.7 CFM

Supply Fan: Cmd Status Alarm  
Supply Air: 154.5 °F, 546.5 CFM

HW Valve: 100.0%  
Room F12 Space: 66.5 °F

Unit Status: Unit Lockout Off, Control Temp Value 67.9 °F, Calculated Discharge SP 110.0 °F, Current Cooling SP 71.0 °F, Current Heating SP 70.0 °F, Schedule Mode Force Day, Schedule Day, Warmup Mode Off, Cooldown Mode Off, Outside Enthalpy 13.3 Btu/lbs, Economizer Enable Off, Duct Smoke Alarm Off, Low Limit Alarm Off, Dirty Filter Alarm Off

Unit Setpoints: Temp Control Mode Return Temp 71.0, Occupied Space SP 71.0, Cooling Offset SP 0.0, Heating Offset SP 1.0, Max Discharge Air SP 110.0, Min Discharge Air SP 55.0, Warmup Supply Air SP 125.0, Cooldown Supply Air SP 55.0, After Hours Time Limit 4.0, Unocc Clg SP 75.0, Unocc Htg SP 62.0, Spc Carbon Dioxide SP 950.0

Economizer: OA-T Enthalpy SP 19.0, Minimum Position 0.0, Econo Manual Signal 0.0, Econo Mode Manual

Hot Water Valve: HW Valve Manual Signal 100.0, HW Valve Mode Manual, Heat OA-T Lockout SP 60.0, Heat Night OA-T SP 60.0, Heat Night Position 70.0

**ATTACHMENT 2.  
WESTON INTERMEDIATE SCHOOL REPORT**

**HVAC Ventilation Review**  
**Weston School District**  
**Intermediate School**

3/20/2026

*Scope*

The HVAC systems were inspected from 2/17 to 2/20 to evaluate operation with emphasis on ventilation. This report summarizes the systems and describes the ventilation operation as found and reviewed on site. Observations cover outdoor entry paths, filters, and control system review.

*Key Findings*

- The multi-zone variable air volume rooftop units are supplying less than the desired system air flow. The classroom units are supplying less total air than the minimum required outdoor air flow. The other units have the capability to increase fan speed with a high duct pressure set point that should approach the flow set points. The system operation should be addressed before outdoor air flow evaluations are considered.
- The outdoor air flow stations are not reading meaningful values. They are not used for control. The outdoor air is set by the minimum outdoor damper position in coordination with the return fan speed offset.
- Units that lack blank off panels in the filter racks are allowing air to bypass around the ends of the filters resulting in dirty coil inlet faces (RTU-1, 7).
- RTU damper actuation should be verified. Observations noted some dampers open when the units are off or not closing completely. A relief damper that is erroneously open could contribute to the observed reduction in system air flow by exhausting excess return air.
- Several of the VAV air terminal heating air flow setpoints on RTU-2 are below the minimum cooling setpoint. This is unusual as the cooling minimum is typically set to meet the minimum zone ventilation requirements. Possibly these set points have been adjusted over the years as they are readily accessible on the BAS graphics screen.
- The BAS has no VAV terminal summaries making it difficult to review system level operation. Summaries like those in place at the high school would facilitate operational reviews. For instance, large numbers of terminals that are short of air flow as observed would be readily apparent. Currently one must page through each VAV graphic and note conditions for comparison.

Intermediate school classrooms are served by central variable air volume rooftop air handlers. Common areas are served by single zone air handlers. The air handlers were installed as part of a 2003 remodel based on mechanical drawings.

*Multi-Zone Air Handlers*

Classroom and office spaces are supplied by variable air volume rooftop air handlers. Each zone (classroom or small group of rooms) has an air terminal that heats and varies the air flow supplied to the zone based on heating and cooling needs. The air handler responds to the varying air flows by adjusting the fan speed to maintain a supply duct pressure. The original design called for air flow monitoring stations to control the outdoor air dampers so that as the system air flow changed the outdoor air damper would modulate to maintain a constant outdoor air flow. The air flow stations are not reading. The current controls maintain the outdoor damper at a fixed minimum position. The BAS history shows that this minimum damper position has been adjusted over the years. The issue with a fixed minimum is that it is often set and outdoor air verified at full system flow (all the zone air terminals – VAV boxes at their maximum design flow). As the system flow drops with reduced load the fixed damper position causes less outdoor air to be introduced to the system flow stream. This is why the original design called for the outdoor air to be measured and control the damper to maintain the required flow rate across all system flows. Without accurate flow stations it is possible to maintain a steady outdoor air flow by resetting the minimum damper position with supply fan speed. The fan speed is a proxy for system air flow. The current controls don't reset the minimum damper position.

The original design control sequence noted the design system flow, minimum outdoor air flow and zone flow ranges. Typically, a testing and balance report would note the outdoor damper position and airflow station calibration that provides the design outdoor air volume. These records have not been found.

Outdoor airflow is not only influenced by the damper position. The AHUs also have return fans. The difference in speed of the return fan from the supply fan impacts the amount of outdoor air that enters through a partially open damper. Currently all the return fans operate at a fixed speed difference from the supply fan. Offsets are 10% below the supply fan speed.

Another factor impacting the delivery of outdoor air is the ability of the system to maintain set point air flows. AS found the units were unable to meet most of the zone air flow set points. The classroom units were supplying total system air flow below the design minimum required outdoor. It is unclear if the dampers in the RTUs are operating properly. Some relief dampers were found open when the units were off. If the dampers are not able to close much of the return air might be exhausted contributing to the reduced total system air flow.

The outdoor air fraction was estimated by the temperatures of the mixed air stream in the AHU. The outdoor flow rate was then calculated from the OA fraction applied to the sum of the air terminal flows reported in the BAS. The accuracy of this method depends on the mixed air temperature representing the actual mixed air conditions. The sensor is an averaging sensor strung across the air path usually just downstream of the filters or near the first coil.

There are no summary tables of the VAV air terminals in the BAS, so airflow values had to be manually captured from the BAS floor plan graphics. Adding summaries like those at the High School would facilitate overall system reviews and make flow issues more apparent.

The summary table extracts key items from the calculation tables in the review notes. All systems supply less than the requested system air flow even when fans were near full speed. RTU-4 and 5 appear they could achieve system air flow if the duct pressure setpoints were allowed to increase. The shortage in system air flow in RTU-1 and 2 results in air flow below the minimum required outdoor air flow. System flow shortages need to be resolved before outdoor air fractions can be addressed.

Multi-Zone VAV RTU Outdoor Air Summary				
	RTU-1	RTU-2	RTU-4	RTU-5
System Air Flow (Sum of VAVs)	8,219	5,555	3,041	4,093
System Air Flow Set Point	14,875	12,339	5,450	5,442
Design Air Flow (2003 schedule)	23,070	10,250	7,100	13,200
Calculated OA fraction from MA-T	25%	35%	3%	30%
Calculated OA flow	2,068	1,939	89	1,234
Design Min OA flow (2003 Schedule)	9,160	10,250	2,500	2,170
OAAFMS reading	NR	NR	NR	NR
OA Damper Position (% open)	20%	25%	0%	20%
Supply Fan Speed	90%	85%	71%	70%
Supply Duct Pressure (in wc)	0.29	0.71	0.91	0.75
OA Flow Condition	Needs Attention	Needs Attention	Needs Attention	Needs Attention

The issues table below notes specific issues and notes the individual zone VAV air terminals that need attention to their air flow dampers or flow sensors. Providing adequate outdoor air to individual spaces requires that the air terminals are fully functional. At this point in the equipment life, the air flow stations are not used in the control sequence and are merely informational. If they could be reconditioned and calibrated, they would provide an ongoing verification of outdoor air delivery.

Issues

RTU-1	Total system air flow is deficient. As found the unit was only able to achieve 55% of the requested air flow or 36% of its design maximum air flow with the fans nearly at full speed. The total supplied air flow is less than the design minimum outdoor air flow of 9,160 cfm
RTU-1 C208 2-26 5 <sup>th</sup> Grade	Air terminal damper or flow sensor issue. Reported airflow exceeds set point when damper is commanded closed.
RTU-1	Outdoor air flow station reading is erroneous. Often shows negative values. Flow units show feet per minute on the RTU graphic and cfm on set point page.
RTU-1	Outdoor damper does not close completely when unit is off.
RTU-1	Filters lack blank off panels allowing air to bypass around end of filters.
RTU-2	Total system air flow is deficient. As found the unit was only able to achieve 45% of the requested air flow or 19% of its design maximum air flow with the fans at 85% full speed. The total supplied air flow is less than the design minimum outdoor air flow of 10,250 cfm.
RTU-2	Outdoor air flow station reading is erroneous. Flow units show feet per minute on the RTU graphic.
RTU-2 A103 1-07 Conf Rm RTU-2 D132 Special Serv. RTU-2 D112 3 <sup>rd</sup> Grade RTU-2 D217 4 <sup>th</sup> Grade RTU-2 D223 4 <sup>th</sup> Grade	The maximum heating air flow set points are below the minimum cooling setpoint. This is unusual since the minimum cooling flow is typically set based on the minimum space ventilation requirements.
RTU-4	System is operating at only 56% of the setpoint air flow with reduced fan speed and static pressure at 0.91 in wc. Is set point limited? Fan should be able to run faster to increase air flow toward set point.
RTU-4	Minimum outdoor air damper setpoint is 0% providing no outdoor air to the system.
RTU-4	Outdoor air flow station reading is erroneous showing 0 fpm. Flow units show feet per minute on the RTU graphic rather than cfm.
RTU-4 1-04 Room 119 RTU-4 1-05 Room 119	VAV air terminals show no heat rise with heating valve open 100% and room temperature below set point.
RTU-5	Duct pressure set point is too low to achieve flow set point with fans speed at only 70%.
RTU-5	Outdoor air flow station reading is erroneous showing 201 fpm rather than cfm.

*Single Zone Rooftop Air Handlers*



Common spaces are served by single zone rooftop units. The outdoor air damper sets the outdoor air flow. The table below summarizes the outdoor air flow fraction from the mixed air temperatures. There are no system air flow measurements. The design air flows from the 2003 schedules are shown for reference. Based on the calculated fraction of outdoor air the systems appear to be supplying adequate outdoor air if they are operating near their original design flow.

Single-Zone RTU Outdoor Air Summary			
	RTU-3	RTU-6	RTU-7
Design Air Flow (2003 schedule)	9,800	8,100	8,360
OA-T (F)	34.8	35.2	35.2
RA-T (F)	69.3	73.0	69.8
MA-T (F)	51.3	65.5	62.6
Calculated OA fraction from MA-T	43%	53%	23%
Design Min OA flow (2003 Schedule)	4,820	3,600	600
OA AFMS reading	NR	NR	NR
OAD Damper Position (% open)	10%	10%	5%
OAF Flow Condition	Adequate	Adequate	Adequate

Issues are itemized below.

RTU-3	Relief damper remained open when the unit was off.
RTU-6	No issues
RTU-7	Relief damper remained open when the unit was off.
RTU-7	Filters lack blank off panels allowing air to bypass around end of filters.
RTU-7	Coil inlet face is dirty

**HVAC Review Notes**

Priority	High
Tag	RTU-1
Location	Roof
Service	Classrooms East
Type	Multi-Zone VAV
Outdoor Air	AFMS in door with louver
Filters	4 Inch
	Unit Overview
	Return air section with outdoor air dampers – right AFMS in door with intake louver OA dampers do not close completely with unit off
	



Filters lack blank off panels at end allowing dirty air to bypass filters



Coil inlet face

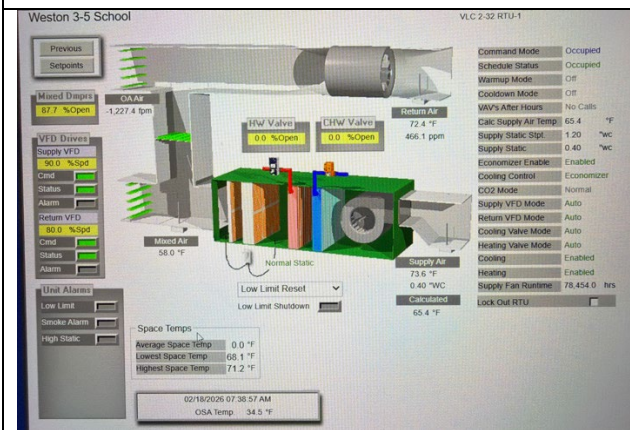

RTU-1 Classrooms East Zone	As Found Flow 2/19 11:15 am				BAS Set points		
	Stpt	cfm	dpr %	Flow %	Max Cool	Min	Max Heat
VLC 2-01 Custodial C106	150	151	42	101%	1000	150	1000
VLC 2-05 Health C101	660	173	100	26%	720	250	660
VLC 2-06 3rd Grade C102	200	184	100	92%	720	200	650
VLC 2-16 3rd Grade C103	250	246	68	98%	750	250	600
VLC 2-17 3rd Grade C104	350	308	100	88%	720	350	650
VLC 2-18 3rd Grade C105	550	415	100	75%	600	200	550
VLC 2-19 4rd Grade C107	650	211	100	32%	740	250	650
VLC 2-20 Comp Room C108	1000	355	100	36%	1400	250	1000
VLC 2-21 3rd Grade C109	650	257	100	40%	740	200	650
VLC 2-22 Staff Workroom C123	450	341	100	76%	1000	200	450
VLC 2-23 3rd Grade C111	750	419	100	56%	890	200	750
VLC 2-24 5th Grade C211	475	480	39	101%	750	250	475
VLC 2-25 5th Grade C210	800	130	100	16%	820	100	800
VLC 2-26 5th Grade C208	180	298	0	166%	800	180	800
VLC 2-27 5th Grade C209	1000	278	100	28%	600	200	1000
VLC 2-28 5th Grade C207	450	454	26	101%	1600	450	600
VLC 2-33 5th Grade C205	500	503	60	101%	1500	500	800
VLC 2-34 5th Grade C204	950	360	100	38%	1500	300	950
VLC 2-35 5th Grade C203	950	209	100	22%	1500	200	950
VLC 2-37 Read Rm C230	480	120	100	25%	810	125	480
VLC 2-38 5th Grade C202	600	165	100	28%	1500	150	500
VLC 2-39 Read Room C229	770	253	100	33%	810	200	480
VLC 2-40 Conf Room C228	210	181	100	86%	210	100	190
VLC 2-41 Conf Room C227	150	52	100	35%	200	100	150
VLC 2-42 5th Grade C201	900	895	44	99%	1500	900	950
VLC 2-43 Special Ed C200	800	781	100	98%	1780	300	800
<b>TOTAL</b>	<b>14875</b>	<b>8219</b>			<b>25160</b>	<b>6555</b>	<b>17535</b>
Design Air Flow (cfm)	<b>23070</b>						
OA-T (F)	42.5						
RA-T (F)	72.7						
MA-T (F)	65.1						
<b>Temp Calc OA Fraction (%)</b>	<b>25%</b>						
<b>Calculated outdoor air (cfm)</b>	<b>2,068</b>						
BAS AFMS OA (cfm)	NR						
Design Outdoor Airflow (cfm)	9,160						
Minimum OA Damper (%)	20%						
Duct Pressure (in wc)	0.29						
Supply Fan Speed (%)	90%						
Retrun Fan Speed (%)	80%						
<b>Notes</b>							
	Flow is less than 85% of maximum flow set point with damper open 100%						
	Air flow more than set point with damper closed - flow or damper issue						
	AFMS reading is erroneous						
	Total system flow is less than the design outdoor air flow requirement. The minimum system flow set point is 6555 but the unit was only able to achieve 8220 cfm (36% of design or 55% of current flow set point) with fans near full speed.						

**HVAC Review Notes**

Priority	High
Tag	RTU-2
Location	Roof
Service	Classrooms West & Admin
Type	Multi-Zone VAV
Outdoor Air	AFMS in door with louver
Filters	4 Inch
	Unit Overview
	Outdoor air damper near (closed) Return air damper far (open)
	Mixed air temperature sensor



Coil inlet face

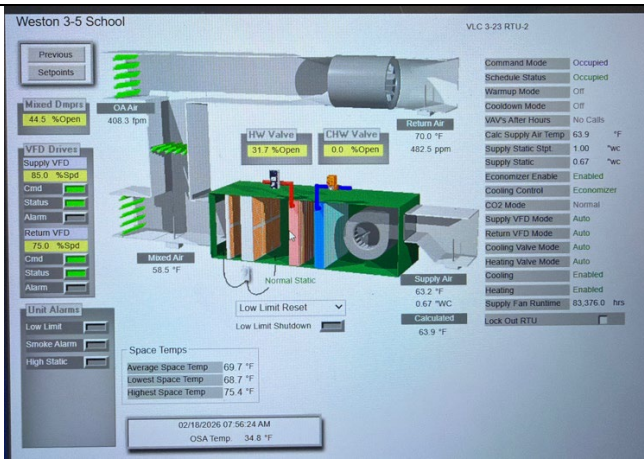

RTU-2 Classrooms West & Admin	As Found Flow 2/19 11:15 am				BAS Set points		
Zone	Stpt	cfm	dpr %	Flow %	Max Cool	Min	Max Heat
VLC 1-06 Book Storage A104	390	63	100	16%	390	115	230
VLC 1-07 Conf Rm A103	400	147	100	37%	870	500	400
VLC 3-01 Office D104	200	44	100	22%	435	200	200
VLC 3-02 Reception D113	250	124	100	50%	450	250	250
VLC 3-03 Art D118	500	244	100	49%	1240	325	500
VLC 3-04 General Office D114	443	259	100	58%	1000	250	700
VLC 3-05 Principal D124	450	186	100	41%	450	75	300
VLC 3-06 Conf Rm D125	100	100	43	100%	1000	100	300
VLC 3-07 Asst Principal D126	300	127	100	42%	400	150	300
VLC 3-08 Break Rm D127	250	141	100	56%	450	150	250
VLC 3-09 Mailroom D115	321	69	100	21%	500	200	300
VLC 3-10 Art D117	300	303	56	101%	1220	300	400
VLC 3-11 Conf Rm D128	250	66	100	26%	450	150	250
VLC 3-12 Guidance D131	975	438	100	45%	975	150	300
VLC 3-13 Psych D123	250	249	78	100%	1200	250	250
VLC 3-14 Special Serv Conf D132	250	249	57	100%	670	250	150
VLC 3-15 Special Ed Res D116	400	404	92	101%	700	150	400
VLC 3-16 Special Ed Res D115	200	201	39	101%	700	200	250
VLC 3-17 3rd Grade D114	250	252	55	101%	840	250	600
VLC 3-18 3rd Grade D113	400	112	100	28%	740	400	400
VLC 3-19 3rd Grade D112	500	232	100	46%	1200	700	500
VLC 3-26 4th Grade D216	1050	110	100	10%	1420	420	1050
VLC 3-27 4th Grade D217	380	378	62	99%	1420	550	380
VLC 3-28 4th Grade D218	1050	194	100	18%	1420	420	1050
VLC 3-30 4th Grade D221	1000	517	100	52%	1560	700	1000
VLC 3-33 4th Grade D223	380	200	100	53%	1560	600	380
VLC 3-34 4th Grade D225	1100	146	100	13%	1560	460	1100
<b>TOTAL</b>	<b>12339</b>	<b>5555</b>			<b>24820</b>	<b>8265</b>	<b>12190</b>
Design Air Flow (cfm)		<b>28800</b>					
OA-T (F)		43.9					
RA-T (F)		69.4					
MA-T (F)		60.5					
Temp Calc OA Fraction (%)		<b>35%</b>					
Calculated outdoor air (cfm)		<b>1,939</b>					
BAS AFMS OA (cfm)		<b>NR</b>					
Design Outdoor Airflow (cfm)		10,250					
Minimum OA Damper (%)		25%					
Duct Pressure (in wc)		0.71					
Supply Fan Speed (%)		85%					
Retrun Fan Speed (%)		75%					
<b>Notes</b>							
							Flow is less than 85% of maximum flow set point with damper open 100%
							Heating maximum set flow set point is less than the minimum cooling set
							AFMS reading is erroneous
							Total system flow is less than the design outdoor air flow requirement. The minimum system flow set point is 8265 but the unit was only able to achieve 5555 cfm (19% of design or 45% of current flow set point) with fans at 85% of full speed.

**HVAC Review Notes**



Priority	Medium
Tag	RTU-3
Location	Roof
Service	Cafeteria
Make	Single Zone Constant Volume
Outdoor Air	Side inlet with bird screen under shroud
Filters	4 Inch
	Unit Overview
	Relief damper is open when unit is off
	Coil inlet face

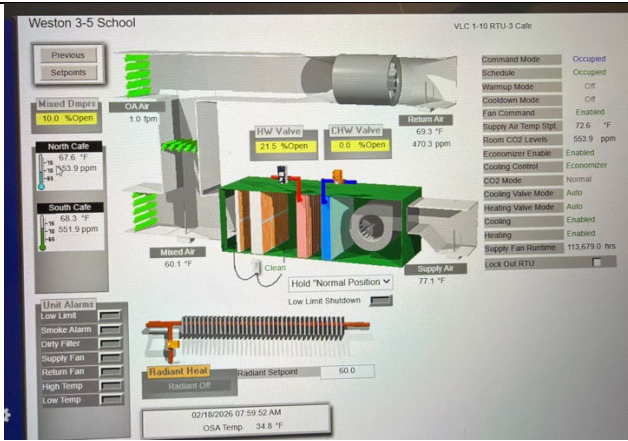

Mixed air temperature sensor at filter inlet.  
Part of sensor is close to outdoor air intake.



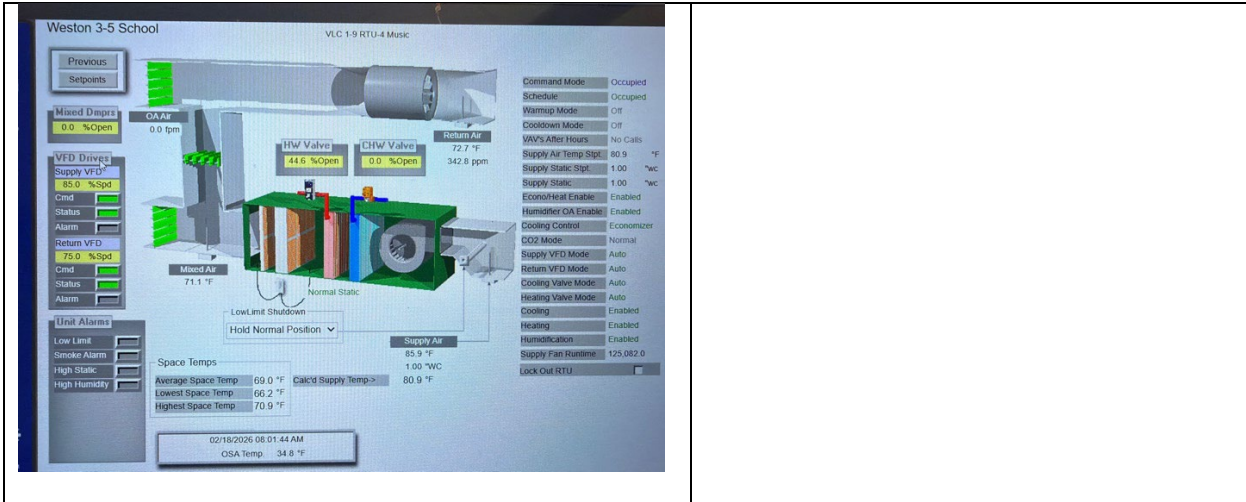

**HVAC Review Notes**

Priority	High
Tag	RTU-4
Location	Roof
Service	Music
Type	Multi-Zone VAV
Outdoor Air	Side inlet with bird screen under shroud
Filters	4 Inch MERV-8
	Unit Overview
	Mixed air temperature sensor across filter inlet. Part of sensor is near outdoor air intake,
	Coil inlet face



RTU-4 Music	As Found Flow 2/19 11:15 am				BAS Set points		
Zone	Stpt	cfm	dpr %	Flow %	Max Cool	Min	Max Heat
VLC 1-01 Staff Rm	1550	1353	100	87%	1550	275	650
VLC 1-02 Staff Rm	1200	137	100	11%	1200	200	650
VLC 1-03 Music Rm 121	800	801	57	100%	1600	800	659
VLC 1-04 Music Rm 119	950	513	100	54%	1200	800	950
VLC 1-05 Music Rm 119	950	237	100	25%	1200	800	950
<b>TOTAL</b>	<b>5450</b>	<b>3041</b>			<b>6750</b>	<b>2875</b>	<b>3859</b>
Design Air Flow (cfm)	7100						
OA-T (F)	44.0						
RA-T (F)	71.4						
MA-T (F)	70.6						
Temp Calc OA Fraction (%)	3%						
Calculated outdoor air (cfm)	89						
BAS AFMS OA (cfm)	NR						
Design Outdoor Airflow (cfm)	2,500						
Minimum OAD Damper (%)	0%						
Duct Pressure (in wc)	0.91						
Supply Fan Speed (%)	71%						
Return Fan Speed (%)	61%						
<b>Notes</b>							
	Flow is less than 85% of maximum flow set point with damper open 100%						
	Minimum outdoor air damper is set to 0% providing virtually no outdoor air.						
	AFMS reading is erroneous						
	VAV air terminals are starved for flow. The pressure setpoint is too low. Fans could be run higher. Flow is only 56% of set point with supply at only 71%						

**HVAC Review Notes**

Priority	High
Tag	RTU-5
Location	Roof
Service	Media Center
Type	Multi-Zone VAV
Outdoor Air	AFMS in door with louver
Filters	2 Inch
	Unit Overview
	Outdoor air flow monitoring station (AFMS) in door with intake louver
	Outdoor air dampers right Return air dampers left



Mixed air temperature sensor at filter outlet



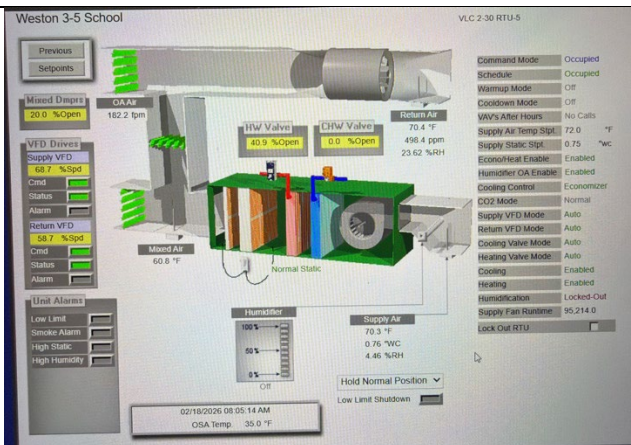

Coil inlet face. Some dirt at bottom of coil.



RTU-5 Media Center	As Found Flow 2/19 11:15 am				BAS Set points		
Zone	Stpt	cfm	dpr %	Flow %	Max Cool	Min	Max Heat
VLC 2-02 Work Prod Rm C102	111	85	100	77%	300	90	150
VLC 2-02 Work Prd rm C102	111	86	100	77%	300	90	150
VLC 2-03 Office WkRm C102	525	83	100	16%	525	60	300
VLC 2-04 Media Center C100	562	554	68	99%	1260	375	550
VLC 2-07 Media Center C100	415	316	100	76%	1360	415	550
VLC 2-08 Media Center C100	337	345	11	102%	1120	337	550
VLC 2-09 Media Center C100	204	204	43	100%	1680	204	550
VLC 2-10 Media Center C100	504	155	100	31%	1680	504	550
VLC 2-11 Media Center C100	504	319	100	63%	1680	504	550
VLC 2-12 Media Center C100	1260	1000	100	79%	1260	378	500
VLC 2-13 Media Center C100	165	175	27	106%	550	165	250
VLC 2-14 Media Cneter C100	504	532	34	106%	1680	504	650
VLC 2-15 Media Class Rm C104	120	119	57	99%	400	120	200
VLC 2-15 Media Center C104	120	120	53	100%	400	120	200
<b>TOTAL</b>	<b>5442</b>	<b>4093</b>			<b>14195</b>	<b>3866</b>	<b>5700</b>
Design Air Flow (cfm)	<b>13200</b>						
OA-T (F)	43.1						
RA-T (F)	70.3						
MA-T (F)	62.1						
Temp Calc OA Fraction (%)	<b>30%</b>						
Calculated outdoor air (cfm)	<b>1,234</b>						
BAS AFMS OA (cfm)	NR						
Design Outdoor Airflow (cfm)	2,170						
Minimum OADamper (%)	20%						
Duct Pressure (in wc)	0.75						
Supply Fan Speed (%)	70%						
Retrun Fan Speed (%)	60%						
<b>Notes</b>							
	Flow is less than 85% of maximum flow set point with damper open 100%.						
	AFMS reading is erroneous - 201 fpm not cfm?						
	Duct pressure set point is too low to achieve desired flow with fan speed only at 70%.						



**HVAC Review Notes**

Priority	Medium
Tag	RTU-6
Location	Roof
Service	Gym
Make	Single Zone Constant Volume
Outdoor Air	Side inlet with bird screen under shroud
Filters	4 Inch MERV 8
	Unit Overview
	Mixed air temperature sensor at filter inlet. Part of sensor is near outdoor air intake.
	Coil inlet face

The screenshot displays a Building Management System (BMS) interface for the 'Weston 3-5 School' at 'VLC 1-12 RTU-6 Gym'. The interface is divided into several sections:

- Top Left:** 'Previous Setpoints' and 'Mixed Dampers' set to 10.0 %Open.
- Left Panel:** 'Avg Space' data showing 66.4 °F and -460.8 Pa. Below are 'North Gym' (66.9 °F, -460.5 ppm) and 'South Gym' (65.9 °F, -491.0 ppm) data.
- Center:** A 3D schematic of the HVAC system with components labeled: OA Air, Economizer (10.0 %), HW Valve (76.5 %Open), CHW Valve (0.0 %Open), Return Air (73.0 °F, 460.5 ppm), Mixed Air (65.5 °F), and Supply Air (71.9 °F). A 'Clean' button is visible below the schematic.
- Right Panel:** A list of system parameters including Command Mode (Occupied), Schedule (Occupied), Warmup Mode (Off), Coolsdown Mode (Off), Fan Command (Enabled), Supply Air Temp Spt (73.3 °F), Room CO2 Levels (459.9 ppm), Economizer Enable (Enabled), Cooling Control (Economizer), CO2 Mode (Normal), Cooling Valve Mode (Auto), Heating Valve Mode (Auto), Cooling (Enabled), Heating (Enabled), Supply Fan Runtime (94.678.0 hrs), Use Return Temp (checked), Use Return CO2 (checked), and Schedule (Occupied).
- Bottom Left:** 'Limit Alarms' section with buttons for Low Limit, Smoke Alarm, Dirty Filter, Supply Fan, Return Fan, High Temp, and Low Temp.
- Bottom Center:** A status bar showing '02/18/2026 08:06:45 AM' and 'OSA Temp 35.2 °F'.

**HVAC Review Notes**

Priority	Medium
Tag	RTU-7
Location	Roof
Service	Lobby & Corridor
Type	Single Zone Constant Volume
Outdoor Air	Side inlet with bird screen under shroud
Filters	4 Inch MERV-13
	Unit Overview
	Filter racks are missing blank off plates at the end of the filter allowing air to bypass filter and clog coil



Dirty coil inlet face

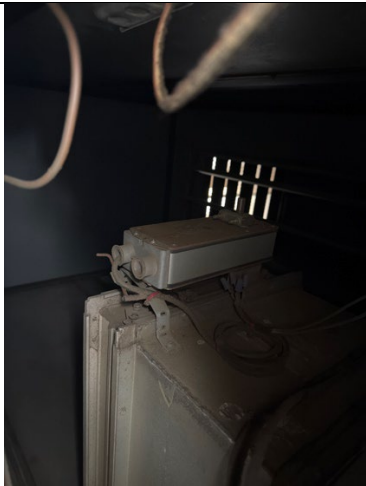

Dampers not closed completely when unit is off

Weston 3-5 School

VLC 1-14 RTU-7

The screenshot displays a control interface for an HVAC system. It includes a 3D diagram of the unit with various components labeled. On the right side, there is a list of settings and status indicators:

Command Mode	Occupied
Schedule	Occupied
Warmup Mode	Off
Cooldown Mode	Off
Fan Command	Enabled
Supply Air Temp Setp	84.1 °F
Economizer Enable	Enabled
Economizer Control	Economizer
CO2 Mode	Normal
Cooling Valve Mode	Auto
Heating Valve Mode	Auto
Cooling	Enabled
Heating	Enabled
Supply Fan Runtime	102,911.0 hrs
Lock Out RTU	

At the bottom, a status bar shows: 02/18/2026 08:10:35 AM, OSA Temp 35.2 °F.

**ATTACHMENT 3.  
HURLBUTT ELEMENTARY SCHOOL REPORT**

**HVAC Ventilation Review**  
**Weston School District**  
**Hurlbutt Elementary**

2/27/2026

*Scope*

The HVAC systems were inspected from 2/17 to 2/20 to evaluate operation with emphasis on ventilation. This report summarizes the systems and describes the ventilation operation as found and reviewed on site. Observations cover outdoor entry paths, filters, and control system review.

*Key Findings*

- The South and East houses have no mechanical ventilation system. They rely on manually opening windows to provide outdoor air.
- The Core area have five air handlers (AHU) with outdoor air introduction through dampers controlled through the building automation system. Two of the units have inoperable outdoor air dampers and are not providing any outdoor air
- The Core are AHUs have air bypassing around filters causing dust building up on the downstream coil. This bypass appears to be due to a gap between the end of the filter and the access door. A spacer unit to fill the gap appears to be missing.
- North House gym Heating AHU (lower unit) outdoor damper is inoperable. The damper is mostly closed.
- The North House gym Cooling AHU (upper unit) does not operate.
- The North House room N9 has a dedicated rooftop unit that is only used for cooling. When the unit is off there is no outdoor air delivered to the room.
- Classrooms with unit ventilators can only supply outdoor air when operating. Currently these units are manually enabled and disabled as requested. Only three of the 15 classroom ventilators were operating their fans and providing outdoor air.
- The North House Make-up Air Unit is supplying tempered outdoor air to eight classrooms and the corridors continuously throughout the day.

*South and East Houses*

The classroom wings have no direct mechanical ventilation system. Outdoor air is provided to classrooms by opening the window. Exhaust fans might enhance outdoor air introduction when the windows are open, but there are no means to ensure that outdoor air is continuously provided due to reliance on manual operation of windows. Even when windows are open, current natural ventilation standards (ASHRAE 62.1) have requirements for opening area based on room dimensions.

*Core*

The core section ventilation is provided by five air handling units circa 1996. Each unit has outdoor air dampers that were designed to work in conjunction with return dampers to adjust outdoor air flow between a minimum required level and added outdoor air for free economizer cooling when outdoor conditions permit. The mixed outdoor and return air is then filtered before entering heating and cooling coils. A building automation system (BAS) is installed to control the units and monitor the system conditions.

Several of the units have dampers that are not operable with actuators disconnected, linkages not connected to dampers or dampers that are inoperable. These units are not providing any outdoor air.

Part of the coil downstream of the filters section are covered in dust due to air blowing by the filter. The filter section has a gap between the end of the filter and the door. A blank-off section is missing allowing dusty air to bypass the filter.

AHU-1 Library

- OA damper closed – no outdoor air flow
- OA damper linkage and control actuator are disconnected
- Near side of coil covered in due to air blowing by filter. Missing blank off section to span gap from end of filter to door.

AHU-2 Hallways

- OA linkage connected to control actuator
- No access to damper and filter without disassembling panel

AHU-3 Computer room

- OA linkage connected to control actuator
- No access to damper and filter without disassembling panel

AHU-4 Offices

- OA damper closed. Damper will not move. No outdoor air flow
- OA damper linkage and control actuator are disconnected
- RA damper closed. Linkage not connected to actuator
- Near side of coil covered in due to air blowing by filter. Missing blank off section to span gap from end of filter to door.

AHU-5 Art room and Nurse

- OA and RA damper linkages connected to control actuator
- Near side of coil covered in due to air blowing by filter. Missing blank off section to span gap from end of filter to door.

Mechanical drawings show the schedule of design values for the core air handling units.

Weston Hurlbutt AHU Schedule			
1996 Drawing Set			
Unit	Airflow (cfm)	Minimum Outdoor Air (cfm)	Outdoor Air Fraction
AHU-1	4,800	1,400	29%
AHU-2	1,950	650	33%
AHU-3	1,980	535	27%
AHU-4	6,000	1,560	26%
AHU-5	6,400	1,500	23%

A snapshot of the BAS screens captures operating conditions. Comparing the mixed air temperature to the return and outdoor air temperatures provides a rough estimate of the outdoor air fraction.

Weston Hurlbutt BAS AHU Data										
2/18/2026 at 8:30 am										
Unit	Temperature (F)			Calc OA%	BAS OA%	Minimum Outdoor Air Damper Command				Note
	Outdoor	Return	Mixed			Current	Since	Previous	Since	
AHU-1	36.0	69.1	68.3	2%	5%	5%	Jan-26	10%	Sep-22	OA damper closed - control disconnected
AHU-2	36.0	68.8	63.3	17%	5%	5%	Jan-26	10%	Feb-25	
AHU-3	36.0	69.6	48.0	64%	5%	5%	Jul-23	10%	Oct-22	
AHU-4	36.0	71.3	45.7	73%	0%	0%	Jul-24	10%	Nov-23	OA damper closed - control disconnected
AHU-5	36.0	68.2	43.9	75%	69%	5%	Jan-26	20%	Mar-23	

Note: AHU-4 found return and outdoor dampers closed - low mixed temperature likely due to leakage through dampers

AHUs 1 and 4 damper controls are disconnected, and the OA damper is closed. AHU-4 also had the return air damper closed so the mixing calculation is meaningless. The cold mixed air temperature was probably due to leakage through the closed OA damper. AHUs 2 and 3 OA dampers could not be visibly inspected without disassembly of the AHU case cover. The data suggest that the AHU-3 damper is open more than expected from the control command. AHU-5 was operating in economizer mode to cool the air resulting on operation exceeding the minimum damper setting.

*North House*

Several different configurations provide outdoor ventilation to the North House including classroom unit ventilators, a central makeup air unit, and a gym air handler.

*Gym AHU*

The gym is ventilated by two dedicated constant volume air handlers. The upper unit contains a cooling coil and is inoperable. The lower unit contains a heating coil with outdoor air and return air dampers to control the outdoor air fraction provided to the space. The dampers are not operational. The control system actuator is disconnected, and the outdoor damper is fixed in a closed position with one blade slightly cracked open. Little to no outdoor air is being provided to the gym.

- OA damper closed. Damper will not move. Some outdoor air enters from top damper that is stuck slightly open.
- OA damper control actuator is disconnected

*RTU – Room N9*

Classroom N9 Has a dedicated rooftop unit that is only used during cooling. There is no ventilation supplied to the room at other times. No outdoor air is being provided to the classroom during most of the school year (no cooling periods).

- No outdoor provided regularly as RTU is only used in summer for cooling
- Pneumatic thermostat controls radiant ceiling panel at windows
- Round electric thermostat control RTU unit

*Classrooms*

Fifteen classrooms have unit ventilators. These cabinet units installed beneath the window have an internal outdoor air damper to provide outdoor air from holes in the brick facade directly behind the units. The outdoor air is mixed with air pulled through the bottom of the cabinet then through a filter by fans mounted just below the grate that delivers air to the space. Eleven of these units are manually controlled by the maintenance staff. Currently the staff responds to a teacher’s request to enable or disable the unit. When the unit is off there is no outdoor air provided to the classroom.

Outdoor air flow was estimated from air velocity measurements at the brick inlet gaps to the unit at 50 to 60 cfm for rooms N16 and N17. There is no access to the outdoor air damper path.

Weston Hurlbutt North House Room Summary			
2/18/26			
Room	OASource	Fan	Average Air Velocity (fpm)
Second Floor			
N01	UV - small	On	25
N02	UV - small	Off	-
N03	JV	Off	8
N04	UV	Off	8
N05	JV	Off	10
N06	UV	Off	15
N100	JV	Off	10
N101	UV - small	Off	-
N102	UV - small	Off	-
N08	JV	Yes	230
N09	RTU		
N10	MAU		
N11	MAU		
N12	MAU		
N13	UV	Off	7
First Floor			
N15	MAU		
N16	UV	On	130
N17	JV	On	80
N18	UV	Off	2
N20	JV	Off	8
N21	MAU		
N22	MAU		
N23	MAU		
N24	MAU		

Note: UV-small are circa 1996

Four units are controlled through the BAS. They are noted to be operating as occupied which would expect to keep the fan continuously operating, but three of the four units were off when inspected. The outdoor damper position is noted with a log of changes over the years. If the fans are allowed to cycle during the occupied period, they will not introduce any outdoor air while off. Note that the Gym AHU outdoor air controls are not connected to the damper.

Weston Hurlbutt BAS Unit Ventilator and AHU Data										
2/18/2026 at 8:40 am										
Unit	Temperature (F)			Calc OA %	BAS OA %	Minimum Outdoor Air Damper Command				Note
	Outdoor	Space	Mixed			Current	Since	Previous	Since	
UV NH-1	35.2	73.7			0%	5%	Mar-15			Fan status off, cycle on
UV NH-2	35.1	72.0			0%	65%	Apr-15			Fan status off, cycle on
UV N-100	34.9	68.6			0%	10%	Mar-15			Fan status off, cycle on
UV N-101	34.9	70.9			0%	100%	Mar-25	10%	Oct-15	Fan status off, low limit alarm
AHU Gym	36.9	68.1	65.6	8%	0%	10%	Sep-22			Fan status on

### *Makeup Air Unit*



A makeup air unit provides outdoor air to the corridors and rooms without unit ventilators. Outdoor air is believed to enter from a louver on the second-floor wall next to the elevator shaft (there are no mechanical drawings of the system) and is routed to the unit in the mechanical room where it is filtered and then conditioned with a heating coil before being distributed to throughout the North House. The BAS monitors this unit but shows a damper mixing return air with the outdoor air. This damper was not found in or near the unit. The BAS implies it controls the position of the damper. Staff is unaware of its location. There is an inlet isolation damper controlled by a pneumatic actuator. Perhaps this is the damper noted on the BAS screen. The nameplate of the unit indicates it was to supply 5,700 cfm of air and designed to raise the air temperature from 0F inlet to 65F outlet.

- Unit is 100% outdoor air with single inlet duct
- Coil state is not viewable due to clamshell style face/bypass dampers
- Controls are pneumatic
  - Inlet isolation damper
  - Heating coil face and bypass damper
- BAS shows damper control at 20%
  - Is it possible this is the inlet isolation damper rather than a return damper as suggested on the BAS graphics?
  - Unit is scheduled to operate 5 am to 10 pm Monday through Friday providing 70F air.
- BAS shows supply temperature controlled by Room NH-16 space temperature rather than maintaining a neutral discharge temperature as typically found on dedicated outdoor air units.
- No test ports were found on the unit to insert an air velocity probe. Unit air flow could be confirmed as well as room distribution flows confirmed from supply register measurements typically performed by a testing and balance contractor.

A dehumidification unit extracts air from the mechanical room holding the make-up unit. The make-up unit has a supply grill to the mechanical room. The dehumidification unit supplies a duct in each classroom. Since it only operates during cooling periods, it is off most of the school year and does not provide outdoor air (from the make-up air unit) to the rooms.

The BAS contains a graphics page labeled "North Science" similar to the gym and makeup air unit graphics with a hot water valve and coil. We did not see any unit designated "Science".

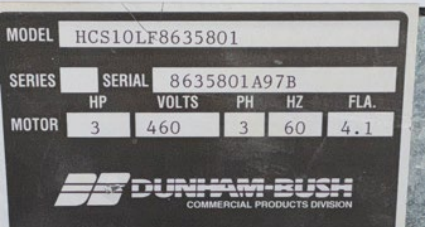
**HVAC Review Notes**

Priority	Medium
Tag	AHU-1
Location	Core Mezzanine
Service	LRC
Make	Dunham Bush
Outdoor Air	Damper linkages are disconnected Control actuator is disconnected
Filters	Dirty coil from blow by through gap between filter end and door
 <p>MODEL HCS10LF8635801 SERIES SERIAL 8635801A97B HP VOLTS PH HZ FLA. MOTOR 3 460 3 60 4.1 DUNHAM-BUSH COMMERCIAL PRODUCTS DIVISION</p>	
	Damper control actuator is disconnected (on the floor) Damper blade linkage is disconnected
	Outdoor air damper (top) is closed). Return air damper is open (left)



Coil face near the door is covered in dust. Air is bypassing filter in gap between filter and door.

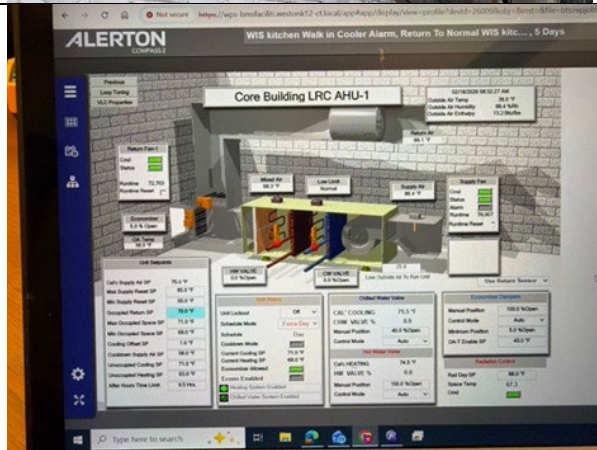

BAS AHU graphics screen. Typical to all units

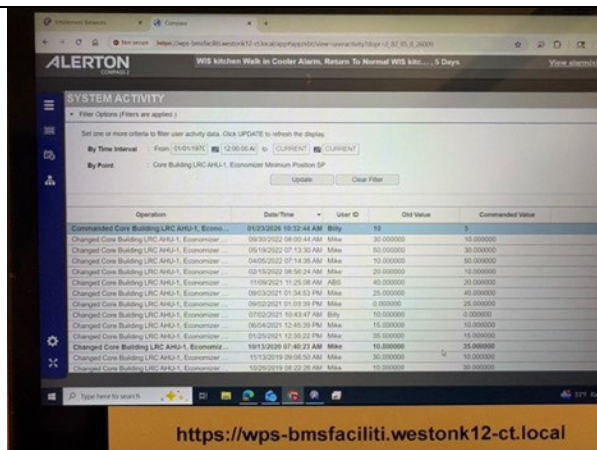

BAS History of outdoor air minimum damper settings. Typical to all units



**HVAC Review Notes**

Priority	Medium
Tag	AHU-2
Location	Core Mezzanine
Service	Hallways
Make	Magic Aire
Outdoor Air	Control actuator is connected tightly to damper linkages No access to damper blades without disassembly panel
Filters	No access to filter without disassembly of panel



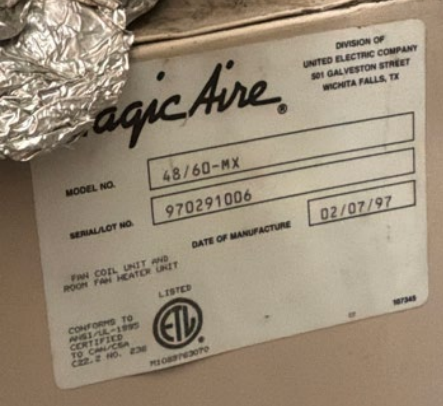

Outdoor and return air damper linkage is tightly secured to the control actuator

**HVAC Review Notes**

Priority	Medium
Tag	AHU-3
Location	Core Mezzanine
Service	Computer Room
Make	Magic Aire
Outdoor Air	Control actuator is connected tightly to damper linkages No access to damper blades without disassembly panel
Filters	No access to filter without disassembly of panel
	
	
	
	Outdoor and return air damper linkage is tightly secured to the control actuator

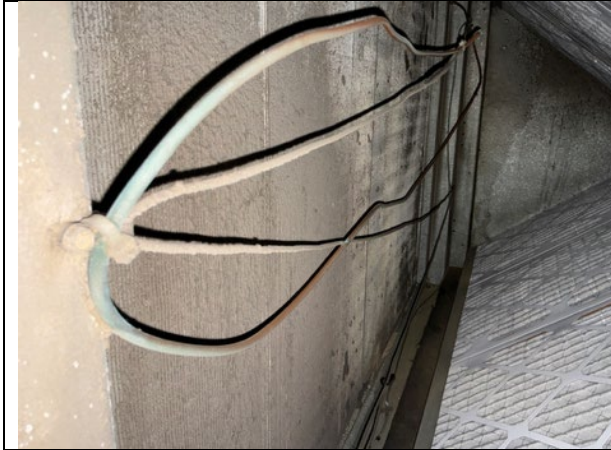

**HVAC Review Notes**

Priority	Medium
Tag	AHU-4
Location	Core Mezzanine
Service	Offices
Make	Dunham Bush
Outdoor Air	Damper linkages are disconnected Control actuator is disconnected OA is closed RA is loose and easily moved – found closed
Filters	Dirty coil from blow by through gap between filter end and door
	
	Return damper linkage connection to actuator is loose. Outdoor damper linkage is disconnected
	Outdoor air damper (top) is closed

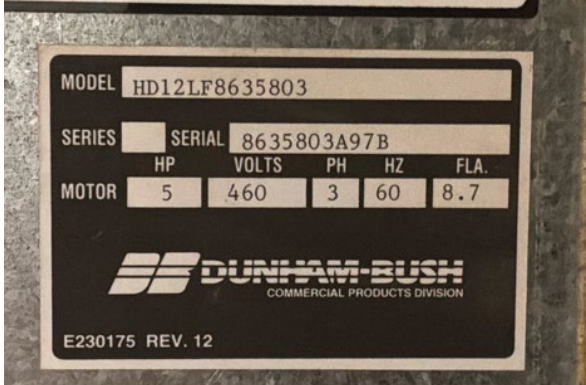

Coil face near the door is covered in dust. Air is bypassing filter in gap between filter and door.

**HVAC Review Notes**

Priority	Medium
Tag	AHU-5
Location	Core Mezzanine
Service	Art and Nurse
Make	Dunham Bush
Outdoor Air	Control actuator is connected tightly to damper linkages RA is closed OA is open
Filters	Dirty coil from blow by through gap between filter end and door
	
	
	Control actuator is connected tightly to damper linkages



Outdoor air damper (top) is open  
Return air damper (left) is closed

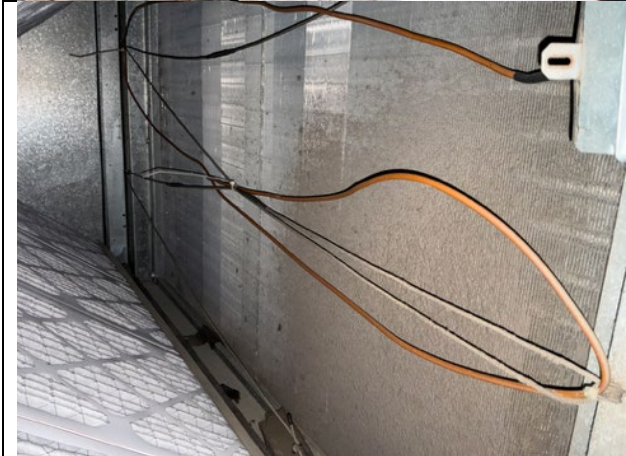



Coil face near the door is covered in dust. Air is bypassing filter in gap between filter and door.



Example filter  
MERV 13 rating

**HVAC Review Notes**

Priority	Medium / High
Tag	--- GYM AHU
Location	North Fan Room
Service	Gym
Make	---
Outdoor Air	Damper linkages are disconnected Control actuator is disconnected OA is closed RA is open
Filters	Clean (all filter replaced every three months)
	Unit overview
	Outdoor air louver (lower)
	Damper actuator disconnected and set on top of unit





Outdoor air damper (left) is closed with one blade cracked open  
Return damper (bottom) is open



Filter section with single point mixed air temperature sensor in front of filter

**HVAC Review Notes**

Priority	Low
Tag	--- Make-up Air Unit
Location	North Basement
Service	Corridors and classrooms without UVs
Make	Control Aire
Outdoor Air	100% OA unit Isolation damper at inlet to unit
Filters	Clean (all filter replaced every three months) 5,700 cfm 0F inlet / 65F outlet air temperatures
	
	Unit overview Pneumatic damper actuator
	Example filter MERV-8 rating



Downstream of heating coil. Clam shell damper blocks view of coil.



Example supply register in corridor

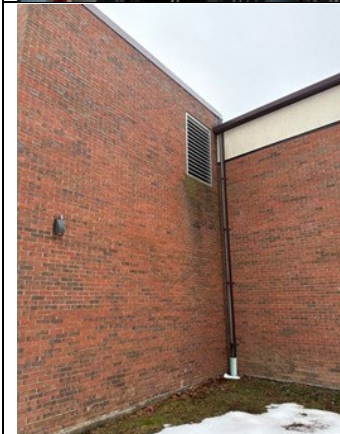

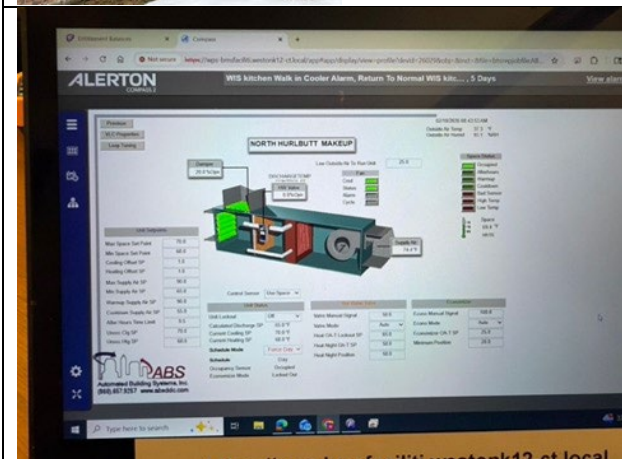

Presumed outdoor air intake louver  
No system drawings available



BAS graphics screen  
No return damper found

**HVAC Review Notes**

Priority	Medium / High
Tag	--- Unit Ventilator
Location	Classroom
Service	Classroom
Make	Nesbitt (oldest units)
Outdoor Air	Outdoor louver beneath window
Filters	At bottom inlet
	
	Unit heater (blue background) Baseboard heat (foreground)
	Example filter at inlet at base of unit



Pneumatic control of heating valve in unit



Outdoor air inlet



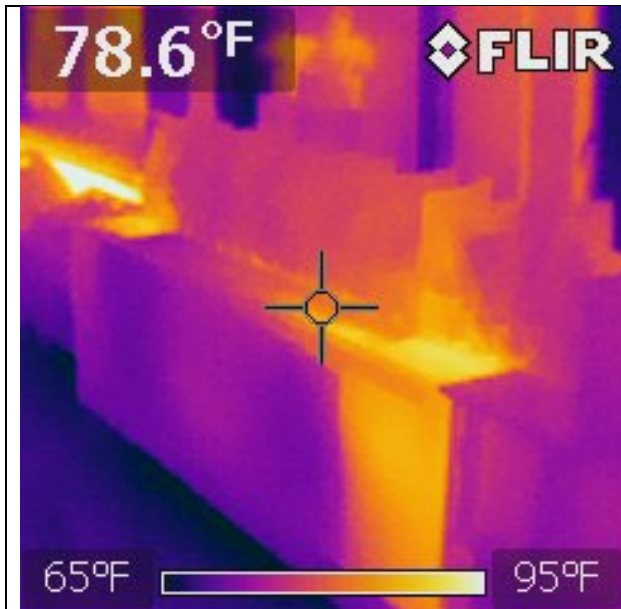

Room N17  
End of unit with heat control valve stays hot

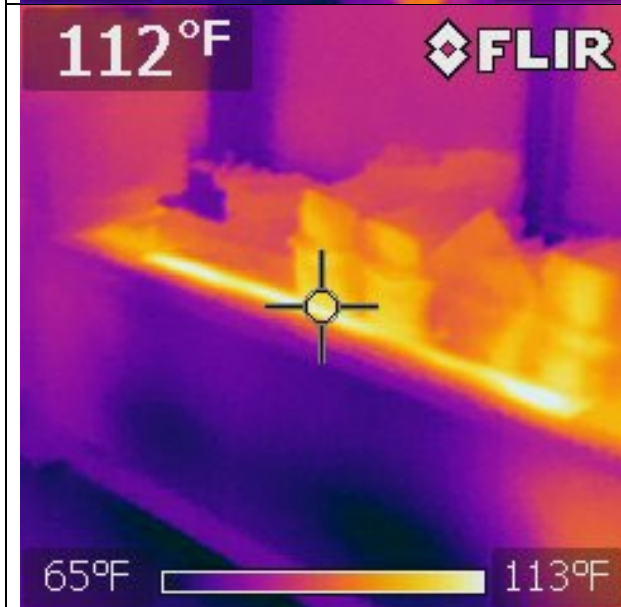

Room N16  
Heat distribution across unit with fan operating



BAS graphics screen (newer units circa 1996)

**ATTACHMENT 4  
SUPPLEMENTAL ACTION PRIORITY INFORMATION**

**HVAC LIFE CYCLE SUMMARY  
2026**

**HVAC LIFE CYCLE SUMMARY**  
**Weston Public School District**  
**Weston, CT**

**Pennoni** is pleased to submit this report for the HVAC life cycle summary performed as part of the February 2026 uniform HVAC inspection and evaluation. Included were Weston High School, Weston Intermediate School and Hurlbutt Elementary School.

The following sections of this report provide an overview of the status of the HVAC systems to help prioritize replacement planning. They also include a summary of each school's HVAC systems, their current condition, and any identified issues.

**HVAC Life Cycle Summary**  
**Weston School District**

The HVAC ventilation systems were inspected 2/17 to 2/20 to review ventilation. Equipment deficiencies related to the ventilation system were noted in the school review reports. This summary organizes action items by suggested priority levels.

Observations on general equipment conditions are discussed below. The tables prioritize equipment replacement by age and condition into three action timing categories: High (2-5 years), Medium (5-10 years), Low (10+ years). A brief operational issues list is also provided with the assumption that these items should be addressed on a high priority. Details are discussed in the individual school reports.

Most life expectancy guidelines note for a 15-to-20-year life with a wide range of variability. Life expectancy is usually defined as the age at which half of the equipment would be replaced. Factors from indoor or outdoor installation, original setup, and attention to maintenance, operating hours of use, etc., have large influences on equipment life. Bearings on fans and motors are impacted by lubrication and hours of use. Flexible seals of the fan outlets to plenum walls become brittle and crack with age. Coils are impacted by air-side cleanliness (filters, etc.) and water-side water treatment chemistry and cleanliness. Dampers and actuators are impacted by cleanliness and hours of use. Most of the major equipment was installed in a 2003 renovation project so they have operated through their life expectancy.

**Equipment Summaries and Replacement Priorities**

High School	Location	Vintage	Note	Action Priority		
				High	Medium	Low
<b>Unit Ventilators</b>						
	13 UVs	C Wing Classrooms	pre 2003		X	
	10 UVs	D Wing Classrooms	pre 2003	X		
<b>VRF / DOAS system</b>						
	DOAS unit	E Wing Roof	post 2003			X
	VRF compressor units	E Wing Roof				
<b>Multi-Zone RTUs (1,2,4,5,7)</b>						
	RTUs	Roof	2003		X	
	VAV terminals	Rooms	2003			X
<b>Single Zone RTUs (3,6,8,9, HV-1,2, Aud)</b>						
	RTUs	Roof	2003		X	
<b>Controls</b>						
	Allerton DDC					
<b>Operational Issues</b>						
	Address UV control to operate fan continuously during occupied period to provide outdoor air			X		
	Install missing filters in dedicated outdoor air unit					
	Address erratic supply duct pressure sensor impactign fna speed control in RTU-1					
	Address VAV air terminal airflows that report above set poitn when damper is closed (RTU- 1,2,5,7)					
	Address low outdoor air flow (RTU-4,7)					
	Review coordiantion of RTU-5 outdoor air flow with exhaust fan and hood operation for potential energy savings					
	Address outdoor air damper actuation (RTU-6, 9, HV-2)					

Hurlbutt Elementary				Action Priority		
Location	Vintage	Note	High	Medium	Low	
<b>Air Handling</b>						
Central 5 AHUs	Indoor - Mezzanine	1997	OA damper issues		X	
Central zone coils	Indoor - Mezzanine	1997	Not reviewed			X
North House RTU	Outdoor - Roof	unknown	Not reviewed. No OA to room N9 when unit is off. (only used for cooling)			
North House Gym AHU Cooling	Indoor - Mech room	unknown	Not functional		X	
North House Gym AHU Heating	Indoor - Mech room	unknown	OA damper non-functional. Exposed motor and fan belt - no safety covering	X		
North House Outdoor Air unit	Indoor - Mech room	unknown	Supplies OA to 8 classrooms and corridors Pneumatic face/bypass and isolation damper controls			X
North House Dehumidification Unit	Indoor - Mech room		Not reviewed			
<b>Unit Ventilators</b>						
11 UVs	Indoor - Classrooms	before 1997	Pneumatic control - manual on/off - 11 units	X		
4 UVs	Indoor - Classrooms	1997	BAS Control		X	
South and East House						
			No Mechanical ventilation	X		
<b>Controls</b>						
Allerton DDC						
<b>Operational Issues</b>				X		
Address lack of outdoor air control on Central Mezz AHUs						
Address filter bypass causing dirty coil						
Address lack of outdoor air to Room N9 when RTU is not operating						
Address lack of outdoor air to North Gym (cooling unit inoperable, heating unit inoperable OA damper)						
Address safety of exposed fan belt outside unit						
Operate UVs continuously during occupied hours to provide outdoor air						
Address South and East House lack of mechanical ventilation						

Intermediate School				Action Priority		
Location	Vintage	Note	High	Medium	Low	
<b>Multi Zone Rooftop units</b>						
RTUs (1,2,4,5)	Outdoors - Roof	2003	Air flows below design. Fixed min OA damper can result in less than required OA at low system flows. Filter bypass causing dirty coil.	X		
VAV terminals	Rooms	2003	Create VAV summary tables			X
<b>Single Zone Rooftop Units</b>						
RTUs (3,6,7)	Outdoors - Roof	2003	Damper issues Filter bypass causing dirty coil		X	
<b>Controls</b>						
Allerton DDC						
<b>Operational Issues</b>				X		
Address limited system air flow in Multi-zone units						
Address filter bypass causing dirty coil (RTU-1,7)						
Address relief damper actuation possibly impacting outdoor air (RTU-3,7)						

WESTON PUBLIC SCHOOLS

FYE 25 FINANCIAL REPORT

As of May 31, 2026

Period: 11 of 12

2022-2023	2023-2024	2024-2025	Object Code	Description	2025-2026							
					Adopted Budget	Budget Transfers	Adjusted Budget	YTD Expended	Encumbered	Anticipated	Expended & Encumbered To EOY	Balance Available
				<b>Salaries &amp; Wages (1000s)</b>								
2,854,614	3,375,352	3,487,109	1110	Administrators	3,593,896	-	3,593,896	3,242,445	275,359	-	3,517,804	76,092
14,827,306	15,169,704	15,671,065	1111	General Ed. Teachers	15,722,608	-	15,722,608	13,130,526	2,604,563	-	15,735,090	(12,482)
2,522,780	2,359,825	2,584,821	1112	Special Ed. Teachers	2,823,721	-	2,823,721	2,246,063	481,851	-	2,727,914	95,808
1,021,018	948,323	984,850	1113	Guidance	1,012,568	-	1,012,568	822,758	195,895	-	1,018,653	(6,085)
397,172	418,788	432,187	1114	Psychologist	468,481	-	468,481	378,389	90,093	-	468,481	-
353,558	410,444	485,393	1115	Social Worker	510,512	-	510,512	393,296	93,031	-	486,327	24,185
539,131	510,769	530,574	1116	Speech & Hearing	548,276	-	548,276	505,891	47,916	-	553,807	(5,531)
887,328	1,261,271	1,275,481	1117	Academic Assistants	1,264,381	-	1,264,381	1,010,539	190,996	-	1,201,535	62,846
110,854	59,724	61,217	1118	Talented & Gifted	-	-	-	-	-	-	-	-
400,239	455,475	456,095	1119	Library /Media	505,044	-	505,044	407,920	97,124	-	505,044	-
57,886	51,774	43,514	1135	Transition Coordinator	56,320	-	56,320	75,815	18,051	-	93,866	(37,546)
847,138	877,957	899,825	1139	Certified Stipends	991,761	-	991,761	742,106	193,600	-	935,706	56,056
651,668	969,094	1,015,169	1140	Academic Leader (CIL's)	955,516	-	955,516	775,725	156,602	-	932,328	23,188
1,852	2,571	1,532	1141	Mentor Teacher	2,300	-	2,300	1,920	-	-	1,920	380
113,090	-	78,000.00	1142	Behavioral Analyst	180,400	-	180,400	145,133	39,538	-	184,672	(4,272)
58,267	68,897	66,541	1145	Multilingual Learner	81,521	-	81,521	74,319	12,736	-	87,055	(5,534)
<b>\$ 25,643,901</b>	<b>\$ 26,939,968</b>	<b>\$ 28,073,373</b>		<b>Sub-Total Certified Salaries</b>	<b>\$ 28,717,306</b>	<b>\$ -</b>	<b>\$ 28,717,306</b>	<b>\$ 23,952,845</b>	<b>\$ 4,497,355</b>	<b>\$ -</b>	<b>\$ 28,450,200</b>	<b>267,105</b>
								83.4%	15.7%	0.0%	99.1%	0.9%
				<b>Other Certified Salaries</b>								
40,788	25,138	24,735	1131	Homebound Tutor	44,500	-	44,500	7,590	3,000	-	10,590	33,910
-	-	-	1136	Degree Level Change	44,390	-	44,390	-	-	-	-	44,390
246,814	216,491	239,946	1137	Substitute Teacher	178,801	-	178,801	155,920	28,187	-	184,107	(5,306)
189,064	194,739	167,395	1138	Summer Work -Certified Staff	212,408	-	212,408	137,583	30,318	-	167,901	44,507
127,403	152,490	140,966	1143	Building Substitutes	203,175	-	203,175	150,833	42,933	-	193,765	9,410
385,336	215,245	251,666	1144	Long term Substitute	118,000	-	118,000	241,172	24,711	-	265,884	(147,884)
-	-	-	1160	Turnover Savings	(370,000)	-	(370,000)	-	-	-	-	(370,000)
<b>\$ 989,404</b>	<b>\$ 804,103</b>	<b>\$ 824,707</b>		<b>Sub-Total Other Certified Salaries</b>	<b>\$ 431,274</b>	<b>\$ -</b>	<b>\$ 431,274</b>	<b>\$ 693,098</b>	<b>\$ 129,149</b>	<b>\$ -</b>	<b>\$ 822,247</b>	<b>\$ (390,973)</b>
								160.7%	29.9%	0.0%	190.7%	-90.7%

**WESTON PUBLIC SCHOOLS**

**FYE 25 FINANCIAL REPORT**

As of May 31, 2026

Period: 11 of 12

2022-2023	2023-2024	2024-2025	Object Code	Description	2025-2026								
					Adopted Budget	Budget Transfers	Adjusted Budget	YTD Expended	Encumbered	Anticipated	Expended & Encumbered To EOY	Balance Available	
				<b>Non-Certified Salaries</b>									
413,013	496,658	497,025	1210	Non-Cert. Supervisors	558,548	-	558,548	502,259	52,117	-	554,376	4,172	
213,706	238,317	223,285	1211	Nurses	250,912	-	250,912	193,753	17,661	-	211,414	39,498	
247,373	279,358	338,189	1215	Occupational & Physical Therapists	345,422	-	345,422	262,885	43,402	-	306,287	39,135	
1,156,839	1,328,818	1,361,800	1221	Administrative Support	1,388,117	-	1,388,117	1,203,460	158,066	6,591	1,368,117	20,000	
1,697,360	1,828,311	1,865,189	1231	Para Educators	1,914,820	-	1,914,820	1,654,558	207,109	53,153	1,914,820	-	
156,413	141,394	108,135	1234	Bus Aides	147,297	-	147,297	79,616	15,000	-	94,616	52,681	
495,877	505,325	523,857	1235	Technicians	537,922	-	537,922	472,629	49,025	-	521,654	16,268	
65,017	46,914	69,477	1237	Vocational Specialist	69,229	-	69,229	60,689	8,540	-	69,229	-	
262,406	276,448	301,659	1241	Safety Monitors	316,063	-	316,063	292,048	21,034	-	313,082	2,981	
513,999	514,241	538,892	1251	Custodians	570,282	-	570,282	515,092	65,093	-	580,185	(9,903)	
477,370	543,741	568,199	1261	Maintenance Mechanics & Grounds	585,183	-	585,183	517,939	67,265	-	585,204	(21)	
90,458	103,682	107,218	1269	Athletic Support Staff	124,751	-	124,751	90,542	20,369	-	110,911	13,840	
192,939	188,200	199,708	1280	Non Certified Stipends	204,550	-	204,550	138,728	59,797	-	198,524	6,026	
<b>\$ 5,982,771</b>	<b>\$ 6,491,408</b>	<b>\$ 6,702,634</b>		<b>Sub-Total Non-Certified Salaries</b>	<b>\$ 7,013,096</b>	<b>\$ -</b>	<b>\$ 7,013,096</b>	<b>\$ 5,984,196</b>	<b>\$ 784,478</b>	<b>\$ 59,744</b>	<b>\$ 6,828,418</b>	<b>\$ 184,678</b>	
								85.3%	11.2%	0.9%	97.4%	2.6%	
				<b>Other Non-Certified Salaries</b>									
39,524	39,305	34,159	1213/1 223/12 33	Non-Certified Substitutes	47,500	-	47,500	44,615	-	2,885	47,500	-	
199,553	230,025	241,665	1212/2 2/38/42 /52/62	Overtime	203,708	-	203,708	229,577	30,000	-	259,577	(55,869)	
114,912	101,739	102,616	1268	Summer Work-Non-Cert.	134,952	-	134,952	113,342	-	-	113,342	21,610	
<b>\$ 353,988</b>	<b>\$ 371,069</b>	<b>\$ 378,440</b>		<b>Sub-Total Other Salaries</b>	<b>\$ 386,160</b>	<b>\$ -</b>	<b>\$ 386,160</b>	<b>\$ 387,534</b>	<b>\$ 30,000</b>	<b>\$ 2,885</b>	<b>\$ 420,418</b>	<b>\$ (34,258)</b>	
								100.4%	7.8%	0.7%	108.9%	-8.9%	
<b>\$ 32,970,064</b>	<b>\$ 34,606,548</b>	<b>\$ 35,979,154</b>		<b>TOTAL SALARIES</b>	<b>\$ 36,547,836</b>	<b>\$ -</b>	<b>\$ 36,547,836</b>	<b>\$ 31,017,672</b>	<b>\$ 5,440,982</b>	<b>\$ 62,628</b>	<b>\$ 36,521,283</b>	<b>\$ 26,553</b>	
								84.9%	14.9%	0.2%	99.9%	0.1%	

**WESTON PUBLIC SCHOOLS**

**FYE 25 FINANCIAL REPORT**

As of May 31, 2026

Period: 11 of 12

2022-2023	2023-2024	2024-2025	Object Code	Description	2025-2026								
					Adopted Budget	Budget Transfers	Adjusted Budget	YTD Expended	Encumbered	Anticipated	Expended & Encumbered To EOY	Balance Available	
				<b>Benefits (2000's)</b>									
9,202,598	8,798,742	9,093,058	2000	Health Insurance	10,623,056	-	10,623,056	9,734,616	938,375	-	10,672,991	(49,935)	
(1,705,489)	(1,410,661)	(1,554,889)	2022	Premium Cost Share	(1,963,364)	-	(1,963,364)	(1,878,319)	(85,045)	-	(1,963,364)	-	
1,020,503	1,032,102	1,067,168	2001	Social Security & Medicare	1,160,817	-	1,160,817	942,846	184,500	-	1,127,346	33,472	
175,214	180,451	186,333	2003	Workers Compensation	191,436	-	191,436	191,383	-	-	191,383	53	
14,848	2,496	35,171	2004	Unemployment Compensation	20,000	-	20,000	12,878	-	1,622	14,500	5,500	
130,080	-	-	2005	Early Retirement Incentive	-	-	-	-	-	-	-	-	
1,328,122	1,192,864	1,325,069	2007	Pension Contributions	1,356,477	-	1,356,477	1,202,989	141,345	-	1,344,334	12,143	
91,124	101,963	54,001	2010	Tuition Reimbursement	85,500	-	85,500	-	85,500	-	85,500	-	
63,051	71,543	72,641	2011-12	Life & Disability Insurance	76,956	-	76,956	72,170	8,374	-	80,544	(3,588)	
56,400	22,381	27,148	2014	Sick Bank	45,000	-	45,000	89,330	-	-	89,330	(44,330)	
<b>\$10,376,450</b>	<b>\$9,991,881</b>	<b>\$10,305,700</b>		<b>TOTAL BENEFITS</b>	<b>\$ 11,595,878</b>	<b>\$ -</b>	<b>\$ 11,595,878</b>	<b>\$ 10,367,892</b>	<b>\$ 1,273,049</b>	<b>\$ 1,622</b>	<b>\$ 11,642,563</b>	<b>\$ (46,684)</b>	
								89.4%	11.0%	0.0%	100.4%	-0.40%	
				<b>Professional &amp; Technical Services (3000s)</b>									
504,232	525,441	174,021	3210	Contracted Services Educational	238,176	-	238,176	172,346	62,003	-	234,348	3,828	
149,405	176,454	154,137	3220-21	Consulting Services	168,935	-	168,935	150,358	32,938	-	183,296	(14,361)	
75,937	94,342	94,477	3235	Testing	144,421	-	144,421	67,349	39,790	-	107,139	37,281	
106,990	260,876	302,332	3239	Other Pupil Services	301,200	-	301,200	251,559	49,945	-	301,505	(305)	
66,056	34,711	37,221	3303	Management Services	37,714	-	37,714	65,853	6,495	-	72,348	(34,634)	
2,064	3,145	2,048	3304	License Fees-Facilities	3,500	-	3,500	5,657	1,110	-	6,767	(3,267)	
232,999	183,838	339,334	3306	Legal Fees-SPED	240,000	-	240,000	169,710	70,290	-	240,000	-	
187,860	162,916	148,456	3306	Legal Fees- Districtwide	150,000	-	150,000	131,498	18,502	-	150,000	-	
106,091	109,322	118,358	3308	Police/Fire	118,741	-	118,741	90,094	28,647	-	118,741	-	
67,685	155,452	123,318	3309	Professional & Technical Services	114,628	-	114,628	82,102	9,035	-	91,137	23,491	
41,996	41,210	54,136	3310	Sports Officials	57,987	-	57,987	-	57,987	-	57,987	-	
<b>\$ 1,541,316</b>	<b>\$ 1,747,705</b>	<b>\$ 1,547,836</b>		<b>TOTAL PROF. &amp; TECH SERVICES</b>	<b>\$ 1,575,301</b>	<b>\$ -</b>	<b>\$ 1,575,301</b>	<b>\$ 1,186,526</b>	<b>\$ 376,741</b>	<b>\$ -</b>	<b>\$ 1,563,267</b>	<b>\$ 12,034</b>	
								75.3%	23.9%	0.0%	99.2%	0.8%	

**WESTON PUBLIC SCHOOLS**

**FYE 25 FINANCIAL REPORT**

As of May 31, 2026

Period: 11 of 12

2022-2023	2023-2024	2024-2025	Object Code	Description	2025-2026								
					Adopted Budget	Budget Transfers	Adjusted Budget	YTD Expended	Encumbered	Anticipated	Expended & Encumbered To EOY	Balance Available	
				<i>Property Services (4000s)</i>									
907,204	969,175	991,847	4200	Cleaning Services	994,738	-	994,738	910,849	83,889	-	994,738	-	
50,825	66,687	65,839	4202	Rubbish Removal	75,877	-	75,877	54,710	11,961	-	66,671	9,206	
82,370	171,370	181,873	4302	Equipment Repairs	188,898	-	188,898	94,403	38,742	-	133,145	55,753	
184,530	189,525	199,670	4400	Equipment Rental	187,115	-	187,115	169,129	38,543	-	207,672	(20,557)	
213,171	210,800	224,644	4500	Repair Allowance	150,000	-	150,000	107,262	135,816	-	243,078	(93,078)	
30,182	40,740	49,171	4514	Fire Alarm System	44,400	-	44,400	56,165	1,585	-	57,750	(13,350)	
201,994	191,606	169,137	4518	Sewer System Plant Maintenance	184,795	-	184,795	236,299	101,525	-	337,825	(153,030)	
205,809	247,875	187,095	4520	Service Contracts	194,724	-	194,724	179,619	61,616	-	241,235	(46,511)	
93,203	74,982	82,676	4530	Parks & Recreation	86,547	-	86,547	60,719	25,828	-	86,547	-	
39,271	31,644	107,951	4540	Athletic Facilities Repairs	59,500	-	59,500	71,231	16,075	-	87,306	(27,806)	
195,029	74,974	111,169	4541	Contracted Services	102,300	-	102,300	47,038	15,278	-	62,317	39,983	
109,755	-	-	4600	Special Projects	-	-	-	-	-	-	-	-	
11,275	6,377	-	4604	Snow Plowing	10,500	-	10,500	-	9,528	-	9,528	972	
35,888	35,100	5,869	4701	Security System Monitoring	10,740	-	10,740	4,158	-	-	4,158	6,582	
<b>\$ 2,360,505</b>	<b>\$ 2,310,853</b>	<b>\$ 2,376,940</b>		<b>TOTAL PROPERTY SERVICES</b>	<b>\$ 2,290,134</b>	<b>\$ -</b>	<b>\$ 2,290,134</b>	<b>\$ 1,991,582</b>	<b>\$ 540,388</b>	<b>\$ -</b>	<b>\$ 2,531,970</b>	<b>\$ (241,836)</b>	
								87.0%	23.6%	0.0%	110.6%	-10.6%	

**WESTON PUBLIC SCHOOLS**

**FYE 25 FINANCIAL REPORT**

As of May 31, 2026

Period: 11 of 12

2022-2023	2023-2024	2024-2025	Object Code	Description	2025-2026							
					Adopted Budget	Budget Transfers	Adjusted Budget	YTD Expended	Encumbered	Anticipated	Expended & Encumbered To EOY	Balance Available
				<b>Other Services (5000's)</b>								
1,592,600	1,737,496	1,724,934	5100	Regular Transportation	1,777,015	-	1,777,015	1,781,236	2,028	-	1,783,264	(6,250)
843,911	935,160	869,290	5101	SPED Transportation	815,957	-	815,957	795,948	122,154	-	918,102	(102,144)
218,024	100,391	113,287	5104	Athletic Transportation	116,093	-	116,093	112,850	3,150	-	116,000	93
12,802	4,237	4,524	5105	Extra-Curricular Transportation	16,360	-	16,360	7,217	290	-	7,507	8,853
160,181	107,032	107,125	5112	Diesel & Gasoline	101,265	-	101,265	79,618	13,386	-	93,003	8,262
128,142	136,003	134,609	5200	General Liability Insurance	154,233	-	154,233	129,547	-	-	129,547	24,686
14,400	15,008	15,008	5202	Athletic Insurance	15,758	-	15,758	15,008	-	-	15,008	751
104,154	106,579	109,196	5205	Property Insurance	114,250	-	114,250	112,350	-	-	112,350	1,901
87,714	89,711	96,937	5300	Communications	94,106	-	94,106	91,080	13,594	-	104,674	(10,568)
27,469	27,030	31,991	5400	Postage	29,383	-	29,383	26,317	2,112	-	28,429	954
853	1,626	2,417	5500	Advertising	2,000	-	2,000	3,515	341	-	3,856	(1,856)
16,962	19,046	18,519	5501	Printing	24,078	-	24,078	15,545	4,367	-	19,912	4,166
2,367,437	2,232,934	2,045,796	5600	Out of District Tuition	1,652,829	-	1,652,829	1,408,873	236,919	-	1,645,792	7,037
1,063,918	1,162,396	1,098,685	5601	Tuition Settlements	1,223,256	-	1,223,256	548,938	493,224	-	1,042,162	181,094
41,076	39,352	44,431	5800	Travel & Conference	59,045	-	59,045	41,038	4,359	-	45,397	13,648
3,803	3,282	2,901	5801	Mileage Reimbursement	14,231	-	14,231	5,506	2,010	-	7,516	6,715
5,684	3,905	12,670	5900	Other Purchased Services	7,310	-	7,310	4,165	1,800	-	5,965	1,345
<b>\$ 6,689,131</b>	<b>\$ 6,721,189</b>	<b>\$ 6,432,319</b>		<b>TOTAL OTHER SERVICES</b>	<b>\$ 6,217,168</b>	<b>\$ -</b>	<b>\$ 6,217,168</b>	<b>\$ 5,178,748</b>	<b>\$ 899,735</b>	<b>\$ -</b>	<b>\$ 6,078,483</b>	<b>\$ 138,685</b>
								83.3%	14.5%	0.0%	97.8%	2.2%
				<b>Supplies &amp; Materials (6000's)</b>								
884,656	897,948	532,944	6110	Materials	697,780	-	697,780	445,808	172,189	-	617,998	79,782
36,390	32,940	29,480	6120	Office Materials	35,328	-	35,328	30,677	14,521	-	45,198	(9,870)
174,050	183,027	192,226	6130	Maintenance Materials	181,624	-	181,624	166,419	36,459	-	202,879	(21,255)
95,137	98,925	132,842	6131	Custodial Materials	78,348	-	78,348	70,903	18,580	-	89,483	(11,135)
21,943	43,776	14,895	6132	Security Materials	26,284	-	26,284	7,109	2,091	-	9,200	17,084
517,581	570,459	642,148	6140	Software	657,407	-	657,407	664,485	21,727	-	686,212	(28,805)
98,833	104,926	105,727	6410	Books	186,730	-	186,730	112,794	15,582	-	128,376	58,354
325,229	467,063	496,828	6510	Heating Oil	515,195	-	515,195	492,286	72,841	-	565,128	(49,933)
482,463	644,985	1,085,613	6520	Electricity	1,056,067	-	1,056,067	757,370	251,989	-	1,009,359	46,708
2,890	2,377	2,870	6530	Propane	3,000	-	3,000	2,007	993	-	3,000	-
<b>\$ 2,639,172</b>	<b>\$ 3,046,427</b>	<b>\$ 3,235,574</b>		<b>TOTAL SUPPLIES &amp; MATERIALS</b>	<b>\$ 3,437,762</b>	<b>\$ -</b>	<b>\$ 3,437,762</b>	<b>\$ 2,749,858</b>	<b>\$ 606,973</b>	<b>\$ -</b>	<b>\$ 3,356,832</b>	<b>\$ 80,930</b>
								80.0%	17.7%	0.0%	97.6%	2.4%

WESTON PUBLIC SCHOOLS

FYE 25 FINANCIAL REPORT

As of May 31, 2026

Period: 11 of 12

2022-2023	2023-2024	2024-2025	Object Code	Description	2025-2026								
					Adopted Budget	Budget Transfers	Adjusted Budget	YTD Expended	Encumbered	Anticipated	Expended & Encumbered To EOY	Balance Available	
				<b>Equipment (7000's)</b>									
192,826	265,378	413,486	7300	Equipment	413,932	-	413,932	363,513	17,541	32,878	413,932	-	
<b>\$ 192,826</b>	<b>\$ 265,378</b>	<b>\$ 413,486</b>		<b>TOTAL EQUIPMENT</b>	<b>\$ 413,932</b>	<b>\$ -</b>	<b>\$ 413,932</b>	<b>\$ 363,513</b>	<b>\$ 17,541</b>	<b>\$ 32,878</b>	<b>\$ 413,932</b>	<b>\$ -</b>	
							87.8%	4.2%	7.9%	100.0%	0.0%		
				<b>Other Objects (8000's)</b>									
87,938	89,475	76,267	8100	Dues, Fees and Memberships	110,106	-	110,106	75,624	26410	-	102,034	8,072	
32,434	39,246	32,768	8900	Other Objects	34,345	-	34,345	22,339	6,715	-	29,054	5,291	
<b>\$ 120,372</b>	<b>\$ 128,721</b>	<b>\$ 109,035</b>		<b>TOTAL OTHER OBJECTS</b>	<b>\$ 144,451</b>	<b>\$ -</b>	<b>\$ 144,451</b>	<b>\$ 97,963</b>	<b>\$ 33,125</b>	<b>\$ -</b>	<b>\$ 131,088</b>	<b>\$ 13,363</b>	
							67.8%	22.9%	0.0%	90.7%	9.3%		
				<b>Revenue Offset (9000's)</b>									
(29,462)	(29,903)	(31,457)	9200	Technology Revenue	(31,946)	-	(31,946)	(33,030)	-	-	(33,030)	1,084	
(74,800)	(78,660)	(75,600)	9201	Participation Fees, Athletics	(70,475)	-	(70,475)	(84,800)	8,480	-	(76,320)	5,845	
(21,689)	(13,475)	-	9202	Gate Receipts, Athletics	(14,000)	-	(14,000)	-	-	(14,000)	(14,000)	-	
(89,987)	(25,495)	(22,425)	9204	Transportation Credits	-	-	-	-	-	-	-	-	
(928,213)	(839,156)	(733,726)	9205	Excess Cost Reimbursement	(526,014)	-	(526,014)	(515,713)	-	-	(515,713)	(10,301)	
(121,242)	(156,288)	(192,195)	9206	Pre School Tuition	(249,209)	-	(249,209)	(256,455)	-	-	(256,455)	7,246	
(119,873)	(141,162)	(121,752)	9207	Non-Resident Tuition	(28,755)	-	(28,755)	(76,359)	-	(12,000)	(88,359)	59,604	
(61,203)	(42,681)	(35,111)	9208	Parks & Rec Portion of Field Maintenance	(72,712)	-	(72,712)	(53,811)	-	(18,901)	(72,712)	-	
(30,800)	-	(24,075)	9209	Parking Fees	(24,075)	-	(24,075)	(24,075)	-	-	(24,075)	-	
(42,223)	(53,727)	(16,870)	9210	Theater Receipts	(51,025)	-	(51,025)	-	-	(35,250)	(35,250)	(15,775)	
-	-	(27,500)	9212	Facility Use Rental	(37,500)	-	(37,500)	(37,500)	-	-	(37,500)	-	
(14,336)	(50,764)	(13,513)	9215	Medicaid Revenue	(18,060)	-	(18,060)	(3,406)	-	(11,654)	(15,060)	(3,000)	
				DRIP Funding - Pending Allocation	-	-	-	(88,826)	-	-	(88,826)	88,826	
<b>(\$1,533,828)</b>	<b>(\$1,431,311)</b>	<b>(\$1,294,225)</b>		<b>Total Revenue Offset</b>	<b>(\$1,123,771)</b>	<b>\$ -</b>	<b>(\$1,123,771)</b>	<b>(\$1,173,974)</b>	<b>\$8,480</b>	<b>(\$91,806)</b>	<b>(\$1,257,300)</b>	<b>\$133,529</b>	
							104.5%	-0.8%	8.2%	111.9%	-11.9%		
<b>\$ 55,356,008</b>	<b>\$ 57,387,390</b>	<b>\$ 59,105,820</b>		<b>GRAND TOTAL</b>	<b>\$ 61,098,689</b>	<b>\$ -</b>	<b>\$ 61,098,689</b>	<b>\$ 51,779,780</b>	<b>\$ 9,197,015</b>	<b>\$ 5,322</b>	<b>\$ 60,982,118</b>	<b>\$ 116,574</b>	
							84.75%	15.05%	0.01%	99.81%	0.19%		



June 12, 2026

**TO:** BOE Finance & Operations Committee

**FROM:** Phillip Cross, Chief Financial & Operations Officer

**SUBJECT:** May Financial Report for FY 25-26

**Financial Summary**

Below is the financial summary for the period ending May 31, 2026 including key trends and highlights.

FY 2025-26 CATEGORY SUMMARY								
Object Series	Adjusted Budget	YTD Actuals	Encumbrance	Anticipated	Total Expenditures	Projected Balance	Previous Month Balance	Month Over Month Change
Salaries (1000's)	36,547,836	31,017,672	5,440,982	62,628	36,521,283	26,553	(70,045)	96,598
		84.87%	14.89%	0.17%	99.93%	0.07%	-0.19%	0.26%
Benefits (2000's)	11,595,878	10,367,892	1,273,049	1,622	11,642,563	(46,684)	(80,805)	34,121
		89.41%	10.98%	0.01%	100.40%	-0.40%	-0.70%	0.09%
Professional Services (3000's)	1,575,301	1,186,526	376,741	-	1,563,267	12,034	17,682	(5,648)
		75.32%	23.92%	0.00%	99.24%	0.76%	1.12%	-0.02%
Property Services (4000s)	2,290,134	1,991,582	540,388	-	2,531,970	(241,836)	(146,183)	(95,653)
		86.96%	23.60%	0.00%	110.56%	-10.56%	-6.38%	-0.26%
Other Services (5000s)	6,217,168	5,178,748	899,735	-	6,078,483	138,686	121,747	16,938
		83.30%	14.47%	0.00%	97.77%	2.23%	1.96%	0.05%
Supplies (6000s)	3,437,762	2,749,858	606,973	-	3,356,832	80,930	116,657	(35,727)
		79.99%	17.66%	0.00%	97.65%	2.35%	3.39%	-0.10%
Equipment (7000s)	413,932	363,513	17,541	32,878	413,932	-	18,971	(18,971)
		87.82%	4.24%	7.94%	100.00%	0.00%	4.58%	-0.05%
Other Objects (8000s)	144,451	97,963	33,125	-	131,088	13,363	8,169	5,194
		67.82%	22.93%	0.00%	90.75%	9.25%	5.66%	0.01%
Revenue (9000s)	(1,123,771)	(1,173,974)	8,480	(91,806)	(1,257,300)	133,529	32,902	100,627
		104.47%	-0.75%	8.17%	111.88%	-11.88%	-2.93%	2.93%
<b>Total</b>	<b>\$ 61,098,691</b>	<b>\$51,779,780</b>	<b>\$ 9,197,015</b>	<b>\$ 5,322</b>	<b>\$ 60,982,118</b>	<b>\$ 116,574</b>	<b>\$ (81,707)</b>	<b>\$ 97,479</b>
<b>Total %</b>		<b>84.75%</b>	<b>15.05%</b>	<b>0.01%</b>	<b>99.81%</b>	<b>0.19%</b>	<b>-0.13%</b>	<b>0.16%</b>

The most significant change this month is the receipt of \$88,826 in DRIP funding, which has positively impacted the projected year-end balance.

Given the fluid nature of the year-end closeout process, a final year-end report will be provided to the Board once the books are closed later this summer.

### **Key Highlights**

DRIP Grant: Established by the general assembly during the 2025 legislative session (section 10-265u). The District Repair and Improvement Project (DRIP) reimburses school districts for eligible minor capital improvements. This is a non-competitive grant with grant awards determined by a state established formula. Based on this formula Weston has received \$88,826.

Additional details regarding the grant can be found on the attached FAQ document.

### **Internal Services Fund**

Total claims and fees are projected to be below budget.

**WESTON PUBLIC SCHOOLS  
INTERNAL SERVICES FUND  
FOR HEALTH BENEFITS PROGRAM**

Fiscal Year Ended		2026
<b>STATEMENT OF REVENUES AND EXPENDITURES</b>		
Fund Balance -July 1, 2025		\$ 418,466
Revenues:		
General Fund		\$ 385,919
Reimbursements		\$ -
Total Contributions		\$ 385,919
Total Revenues (A)		<u>\$ 385,919</u>
Projected Claims:		
Delta Dental:		
Claims		\$ 362,535
Administrative Fees		\$ 23,384
Total Dental Claims (B)		<u>\$ 385,919</u>
Net Change (A-B)		<u>-</u>
Projected Fund balance June 30, 2026		<u>\$ 418,466</u>

**Dental- Actual Claims & Fees**

Month	Claims & Fees
July	27,402
August	44,585
September	26,669
October	29,837
November	23,970
December	25,640
January	34,987
February	28,067
March	31,599
April	27,664
<b>Total</b>	<b><u>\$ 300,419</u></b>
Actual YTD Spend Rate	77.8%
Theoretical YTD Spend Rate	83.3%
YTD Theoretical variance %	-5.5%

Providing a safe and healthy learning environment is essential for ensuring students can succeed in the classroom and beyond. Research consistently shows a safe learning environment can help improve student learning outcomes. Students' overall health and ability to perform academically can be negatively impacted by environmental exposure to mold, poorly ventilated air, uncomfortable temperatures, and inadequate lighting or noise in school buildings.<sup>1</sup> Research has also shown that students from lower socioeconomic backgrounds are less likely to attend school in a building that is in "good" or "excellent" condition.<sup>2</sup>

During the 2025 legislative session, Connecticut made strides toward providing safer, healthier learning environments for students and educators by establishing the District Repair and Improvement Project (DRIP) program. Section 131 of Public Act 25-174 authorizes \$60 million in state general obligation bonds for the DRIP program — \$30 million in both fiscal years 2026 and 2027.<sup>3</sup>

This frequently asked questions document addresses high-level questions pertaining to the establishment of the DRIP program and its impact on public school districts across Connecticut.

#### **What is the District Repair and Improvement Project (DRIP) program?<sup>4</sup>**

The District Repair and Improvement Project (DRIP) program is a new program that provides reimbursement grants to school districts for minor capital repairs and improvements to public school buildings, grounds, and infrastructure.

#### **Who is responsible for oversight of the DRIP program?<sup>5</sup>**

The secretary of Connecticut's Office of Policy and Management (OPM) provides primary oversight of the DRIP program and is responsible for distributing funds, managing reports and record keeping, and overseeing accountability.

#### **Who is eligible for funding from the DRIP program?<sup>6</sup>**

The DRIP program will provide funding to Public School Operators (PSOs) for minor capital repairs, improvements, and maintenance. PSOs are defined as local and regional public school districts, Regional Educational Service Centers (RESCs), the Goodwin University Magnet School System (GUMSS), endowed academies, and state charter schools.

#### **How is the DRIP program funded?<sup>7</sup>**

Similarly to Connecticut's school construction grant program, funding for the DRIP program is sourced from general obligation (GO) bonds authorized by the State Bond Commission. Section 131 of Public Act 25-174 allocates \$60 million in GO bonds for the DRIP program, with \$30 million allocated in both FY 2026 and FY 2027.<sup>7</sup>

### What is the formula used to allocate DRIP funding to eligible PSOs?<sup>8</sup>

DRIP program funding dispersed by the OPM secretary to PSOs is determined by the following formula.

- **50% – Based on the Proportion of Need Students in a District:** 50% of DRIP program funding is allocated proportionally by dividing the need student count (from the prior fiscal year) of the PSO receiving funding by the sum of all PSO need student counts for the same prior fiscal year.
  - **A PSO's yearly need student count is defined as the:**
    - Total number of students enrolled in the PSO; **plus**
    - 30% of the number of students enrolled in the PSO who are eligible for free or reduced-priced meals or free milk; **plus**
    - For PSOs with over 60% of their enrolled students eligible for free or reduced-price meals or free milk, an additional 15% of the number of eligible students above the 60% threshold; **plus**
    - 25% of the number of students enrolled in the PSO who are multilingual learners; **plus**
    - 30% of the number of students enrolled in the PSO who require special education services.
- **20% – Evenly Distributed for All Districts:** 20% of DRIP program funding is evenly distributed among all PSOs.
- **30% – Based on District Wealth:** 30% of DRIP program funding is allocated proportionally based on the total number of students enrolled in the PSO during the prior fiscal year, multiplied by the inverse of the adjusted equalized net grand list per capita (AENGLC) of the PSO, divided by the sum of all PSO products resulting from their inverse.<sup>A</sup>

### What is the timeline for the distribution of DRIP program funding?<sup>9</sup>

The timeline for distribution of DRIP program funding is as follows:

1. **Each year on February 1<sup>st</sup>,** the OPM secretary allocates DRIP program funds to each PSO's subaccount. The secretary then maintains records of the funds credited to the account and the actual amount allocated to each PSO during that fiscal year.
2. **On April 1<sup>st</sup> of each year,**<sup>B</sup> the OPM secretary is required to notify each PSO of the allocation amounts to their subaccounts and publicly post the allocation and calculation amounts on the OPM website.
3. The allocation amounts credited to each PSO's subaccount must be issued as grants **by June 30<sup>th</sup> of each fiscal year.**

<sup>A</sup> FY 2026 DRIP program grant allocation amounts by PSO can be found in the Appendix.

<sup>B</sup> For FY 2026, this date was March 1<sup>st</sup>. Section 1 of Conn. Acts 26-137 changed this date to April 1<sup>st</sup> for future fiscal years.

### **What are the eligible uses for DRIP program funding?<sup>10</sup>**

DRIP program funds must assist in at least one of the following areas approved by the PSO:

1. Construction, renovation, repair, or expansion of public school buildings, grounds, and infrastructure;
2. The improvement of school facilities for health, safety, or code compliance; or
3. The purchase, installation, maintenance, or enhancement of fixed infrastructure, which includes, but is not limited to heating, ventilation, and air conditioning (HVAC); plumbing; electrical systems; and roofing.

These funds will also help prevent more expensive repairs in the future and improve access to safe and well-maintained facilities.

### **How does a PSO apply for DRIP program funding?**

PSOs do not need to apply for DRIP program funding. Instead, to access DRIP program funding, the chief executive officer of the PSO simply needs to complete the DRIP program grant certification form by the deadline issued by the OPM.<sup>11</sup>

### **What are the reporting requirements for the DRIP program?<sup>12</sup>**

The creation of the DRIP program introduces several new reporting and record-keeping requirements. Starting September 1, 2027, each PSO that receives a DRIP program grant must submit an annual report to the OPM secretary. This report must confirm that any repairs and improvements funded by the DRIP program have been approved by a PSO, board, council, or other governing body responsible for overseeing the project. Additionally, any DRIP program funds used for reimbursement and costs associated with approved projects cannot be used to fulfill local matching requirements for other state programs or for school building projects eligible under the state's school construction grant program.

Each PSO must also keep detailed accounting records of all expenses related to the DRIP program grant for three years, subject to review by the OPM secretary. If, upon review, the secretary finds records were not properly maintained or a portion of the DRIP program aid was used for ineligible purposes as defined in law, the PSO may be required to repay the full grant amount or have future grant funding reduced.

## Appendix

### FY 2026 DRIP Program Grants by PSO<sup>13</sup>

The table below displays the FY 2026 DRIP program grant amounts for each PSO. Columns 2-4 represent the grant amounts attributable to each formula component outlined above.

Public School Operator	Need Student Portion of Grant	Flat Grant Portion of Grant	Wealth Portion of Grant	Total Grant
ACES	\$56,545	\$30,303	\$26,960	\$113,808
Achievement First Bridgeport Academy	\$36,305	\$30,303	\$37,220	\$103,828
Achievement First Hartford Academy	\$31,459	\$30,303	\$69,491	\$131,254
Amistad Academy	\$37,154	\$30,303	\$34,560	\$102,017
Andover	\$7,011	\$30,303	\$3,487	\$40,801
Ansonia	\$76,724	\$30,303	\$55,427	\$162,453
Ashford	\$11,066	\$30,303	\$6,315	\$47,683
Avon	\$81,588	\$30,303	\$14,416	\$126,307
Barkhamsted	\$7,074	\$30,303	\$2,400	\$39,777
Berlin	\$74,672	\$30,303	\$23,913	\$128,889
Bethany	\$12,371	\$30,303	\$3,210	\$45,884
Bethel	\$93,973	\$30,303	\$30,551	\$154,827
Bloomfield	\$54,201	\$30,303	\$19,435	\$103,939
Bolton	\$18,497	\$30,303	\$7,876	\$56,675

Public School Operator	Need Student Portion of Grant	Flat Grant Portion of Grant	Wealth Portion of Grant	Total Grant
Booker T. Washington Academy	\$14,524	\$30,303	\$13,234	\$58,061
Bozrah	\$5,503	\$30,303	\$1,962	\$37,768
Branford	\$73,986	\$30,303	\$16,028	\$120,317
Brass City Charter School	\$12,748	\$30,303	\$17,081	\$60,132
Bridgeport	\$708,550	\$30,303	\$679,747	\$1,418,600
Bristol	\$234,982	\$30,303	\$146,290	\$411,575
Brookfield	\$71,718	\$30,303	\$18,788	\$120,809
Brooklyn	\$24,701	\$30,303	\$15,225	\$70,229
C.E.S.	\$24,015	\$30,303	\$6,515	\$60,833
Canaan	\$2,089	\$30,303	\$414	\$32,806
Canterbury	\$14,365	\$30,303	\$7,341	\$52,009
Canton	\$40,137	\$30,303	\$12,597	\$83,037
Capital Preparatory Harbor School	\$25,162	\$30,303	\$27,262	\$82,727
Chaplin	\$4,326	\$30,303	\$2,282	\$36,912
Cheshire	\$122,210	\$30,303	\$37,456	\$189,969
Chester	\$5,495	\$30,303	\$1,902	\$37,700
Clinton	\$42,109	\$30,303	\$11,833	\$84,244

Public School Operator	Need Student Portion of Grant	Flat Grant Portion of Grant	Wealth Portion of Grant	Total Grant
Colchester	\$59,185	\$30,303	\$30,207	\$119,695
Colebrook	\$1,770	\$30,303	\$452	\$32,525
Columbia	\$12,398	\$30,303	\$5,540	\$48,241
Common Ground High School	\$7,437	\$30,303	\$6,950	\$44,690
Cornwall	\$2,683	\$30,303	\$311	\$33,297
Coventry	\$46,556	\$30,303	\$20,425	\$97,284
CREC	\$297,664	\$30,303	\$119,351	\$447,318
Cromwell	\$51,132	\$30,303	\$16,989	\$98,423
Danbury	\$379,205	\$30,303	\$163,493	\$573,001
Darien	\$124,337	\$30,303	\$4,488	\$159,127
Deep River	\$5,239	\$30,303	\$1,695	\$37,238
Derby	\$35,781	\$30,303	\$25,945	\$92,029
East Granby	\$23,680	\$30,303	\$8,613	\$62,596
East Haddam	\$26,495	\$30,303	\$8,542	\$65,341
East Hampton	\$47,031	\$30,303	\$19,860	\$97,194
East Hartford	\$204,257	\$30,303	\$208,390	\$442,950
East Haven	\$89,807	\$30,303	\$58,621	\$178,730

Public School Operator	Need Student Portion of Grant	Flat Grant Portion of Grant	Wealth Portion of Grant	Total Grant
East Lyme	\$71,257	\$30,303	\$22,551	\$124,110
East Windsor	\$30,929	\$30,303	\$12,125	\$73,356
EASTCONN	\$11,662	\$30,303	\$6,143	\$48,108
Eastford	\$4,713	\$30,303	\$2,059	\$37,075
Easton	\$25,452	\$30,303	\$4,278	\$60,033
EdAdvance	\$8,946	\$30,303	\$2,763	\$42,012
Edmonds Cofield Preparatory Academy	\$1,622	\$30,303	\$1,428	\$33,354
Ellington	\$72,313	\$30,303	\$28,883	\$131,498
Elm City College Preparatory School	\$26,238	\$30,303	\$24,055	\$80,596
Elm City Montessori School	\$9,499	\$30,303	\$10,060	\$49,862
Enfield	\$141,753	\$30,303	\$92,409	\$264,465
Essex	\$8,994	\$30,303	\$1,525	\$40,822
Explorations	\$2,780	\$30,303	\$1,504	\$34,587
Fairfield	\$255,981	\$30,303	\$37,234	\$323,518
Farmington	\$115,100	\$30,303	\$26,839	\$172,242
Franklin	\$5,364	\$30,303	\$1,967	\$37,634
Glastonbury	\$157,059	\$30,303	\$37,629	\$224,991

Public School Operator	Need Student Portion of Grant	Flat Grant Portion of Grant	Wealth Portion of Grant	Total Grant
Goodwin University	\$44,572	\$30,303	\$20,712	\$95,586
Granby	\$47,496	\$30,303	\$16,298	\$94,097
Great Oaks Charter School	\$22,759	\$30,303	\$23,342	\$76,404
Greenwich	\$235,785	\$30,303	\$9,168	\$275,256
Griswold	\$56,438	\$30,303	\$43,875	\$130,616
Groton	\$117,557	\$30,303	\$49,922	\$197,782
Guilford	\$82,806	\$30,303	\$16,537	\$129,646
Hamden	\$164,425	\$30,303	\$98,632	\$293,359
Hampton	\$2,142	\$30,303	\$756	\$33,201
Hartford	\$533,024	\$30,303	\$1,158,035	\$1,721,362
Hartland	\$3,273	\$30,303	\$1,043	\$34,619
Hebron	\$19,389	\$30,303	\$7,842	\$57,534
Highville Charter School	\$15,873	\$30,303	\$16,090	\$62,266
Integrated Day Charter School	\$11,308	\$30,303	\$11,427	\$53,037
Interdistrict School for Arts and Comms	\$10,787	\$30,303	\$9,941	\$51,031
Jumoke Academy	\$19,668	\$30,303	\$47,163	\$97,134
Kent	\$5,337	\$30,303	\$729	\$36,370

Public School Operator	Need Student Portion of Grant	Flat Grant Portion of Grant	Wealth Portion of Grant	Total Grant
Killingly	\$70,741	\$30,303	\$45,447	\$146,492
LEARN	\$45,072	\$30,303	\$14,650	\$90,025
Lebanon	\$26,804	\$30,303	\$9,892	\$66,999
Ledyard	\$66,187	\$30,303	\$38,785	\$135,275
Lisbon	\$11,902	\$30,303	\$6,765	\$48,970
Madison	\$66,386	\$30,303	\$9,722	\$106,411
Manchester	\$190,721	\$30,303	\$125,404	\$346,428
Mansfield	\$27,755	\$30,303	\$56,503	\$114,561
Marlborough	\$13,038	\$30,303	\$4,494	\$47,835
Meriden	\$291,009	\$30,303	\$264,145	\$585,457
Middletown	\$133,422	\$30,303	\$73,999	\$237,724
Milford	\$150,156	\$30,303	\$43,051	\$223,511
Monroe	\$95,499	\$30,303	\$26,225	\$152,027
Montville	\$57,027	\$30,303	\$39,580	\$126,910
Naugatuck	\$127,831	\$30,303	\$88,064	\$246,198
New Beginnings Family Academy	\$14,412	\$30,303	\$15,326	\$60,041
New Britain	\$339,070	\$30,303	\$461,362	\$830,736

Public School Operator	Need Student Portion of Grant	Flat Grant Portion of Grant	Wealth Portion of Grant	Total Grant
New Canaan	\$106,547	\$30,303	\$4,671	\$141,521
New Fairfield	\$59,707	\$30,303	\$16,229	\$106,239
New Hartford	\$12,438	\$30,303	\$3,769	\$46,511
New Haven	\$612,388	\$30,303	\$561,842	\$1,204,533
New London	\$103,207	\$30,303	\$85,644	\$219,154
New Milford	\$103,729	\$30,303	\$38,856	\$172,888
Newington	\$114,951	\$30,303	\$49,694	\$194,948
Newtown	\$108,040	\$30,303	\$27,132	\$165,475
Norfolk	\$1,624	\$30,303	\$305	\$32,232
North Branford	\$44,075	\$30,303	\$16,189	\$90,567
North Canaan	\$7,146	\$30,303	\$3,628	\$41,077
North Haven	\$89,755	\$30,303	\$24,024	\$144,082
North Stonington	\$20,478	\$30,303	\$7,243	\$58,024
Norwalk	\$365,350	\$30,303	\$75,348	\$471,002
Norwich	\$112,179	\$30,303	\$100,268	\$242,750
Norwich Free Academy	\$64,891	\$30,303	\$41,443	\$136,638
Odyssey Community School	\$12,787	\$30,303	\$9,011	\$52,101

Public School Operator	Need Student Portion of Grant	Flat Grant Portion of Grant	Wealth Portion of Grant	Total Grant
Old Saybrook	\$28,812	\$30,303	\$3,670	\$62,785
Orange	\$35,323	\$30,303	\$7,695	\$73,321
Oxford	\$44,835	\$30,303	\$12,692	\$87,830
Park City Prep Charter School	\$14,487	\$30,303	\$15,432	\$60,221
Plainfield	\$56,235	\$30,303	\$40,638	\$127,175
Plainville	\$64,896	\$30,303	\$38,712	\$133,911
Plymouth	\$38,664	\$30,303	\$29,257	\$98,223
Pomfret	\$9,572	\$30,303	\$3,964	\$43,838
Portland	\$35,997	\$30,303	\$18,473	\$84,773
Preston	\$11,775	\$30,303	\$5,294	\$47,372
Putnam	\$36,110	\$30,303	\$24,553	\$90,966
Redding	\$23,354	\$30,303	\$3,065	\$56,722
Regional School District 01	\$9,503	\$30,303	\$2,178	\$41,984
Regional School District 04	\$17,006	\$30,303	\$4,787	\$52,097
Regional School District 05	\$59,244	\$30,303	\$13,014	\$102,560
Regional School District 07	\$22,430	\$30,303	\$6,790	\$59,523
Regional School District 08	\$28,719	\$30,303	\$11,378	\$70,400

Public School Operator	Need Student Portion of Grant	Flat Grant Portion of Grant	Wealth Portion of Grant	Total Grant
Regional School District 09	\$18,778	\$30,303	\$2,707	\$51,788
Regional School District 10	\$57,317	\$30,303	\$19,867	\$107,487
Regional School District 11	\$5,544	\$30,303	\$2,633	\$38,480
Regional School District 12	\$22,890	\$30,303	\$1,912	\$55,105
Regional School District 13	\$36,513	\$30,303	\$12,568	\$79,384
Regional School District 14	\$43,617	\$30,303	\$11,529	\$85,448
Regional School District 15	\$93,526	\$30,303	\$26,572	\$150,401
Regional School District 16	\$54,113	\$30,303	\$24,051	\$108,467
Regional School District 17	\$46,514	\$30,303	\$13,983	\$90,799
Regional School District 18	\$34,719	\$30,303	\$4,373	\$69,394
Regional School District 19	\$28,974	\$30,303	\$31,298	\$90,575
Regional School District 20	\$46,394	\$30,303	\$9,289	\$85,986
Ridgefield	\$120,441	\$30,303	\$14,461	\$165,205
Rocky Hill	\$74,005	\$30,303	\$25,015	\$129,323
Salem	\$11,384	\$30,303	\$5,220	\$46,907
Salisbury	\$7,883	\$30,303	\$745	\$38,931
Scotland	\$2,593	\$30,303	\$1,579	\$34,475

Public School Operator	Need Student Portion of Grant	Flat Grant Portion of Grant	Wealth Portion of Grant	Total Grant
Seymour	\$62,934	\$30,303	\$31,953	\$125,191
Sharon	\$2,834	\$30,303	\$222	\$33,358
Shelton	\$132,262	\$30,303	\$42,834	\$205,399
Sherman	\$6,277	\$30,303	\$696	\$37,276
Side By Side Charter School	\$7,737	\$30,303	\$1,585	\$39,625
Simsbury	\$113,453	\$30,303	\$29,047	\$172,803
Somers	\$35,420	\$30,303	\$17,148	\$82,871
South Windsor	\$146,050	\$30,303	\$44,148	\$220,501
Southington	\$176,966	\$30,303	\$61,863	\$269,132
Sprague	\$7,557	\$30,303	\$5,067	\$42,927
Stafford	\$37,336	\$30,303	\$23,048	\$90,686
Stamford	\$488,409	\$30,303	\$93,023	\$611,735
Stamford Big Picture Learning Academy	\$335	\$30,303	\$55	\$30,693
Stamford Charter School for Excellence	\$16,963	\$30,303	\$3,312	\$50,578
Sterling	\$8,583	\$30,303	\$5,888	\$44,775
Stonington	\$47,381	\$30,303	\$8,851	\$86,535
Stratford	\$201,248	\$30,303	\$79,512	\$311,063

Public School Operator	Need Student Portion of Grant	Flat Grant Portion of Grant	Wealth Portion of Grant	Total Grant
Suffield	\$57,020	\$30,303	\$20,112	\$107,435
The Bridge Academy	\$9,434	\$30,303	\$9,923	\$49,660
The Gilbert School	\$12,975	\$30,303	\$6,565	\$49,842
The Woodstock Academy	\$26,301	\$30,303	\$14,096	\$70,700
Thomaston	\$22,486	\$30,303	\$12,123	\$64,912
Thompson	\$23,974	\$30,303	\$12,260	\$66,537
Tolland	\$58,703	\$30,303	\$21,094	\$110,099
Torrington	\$125,992	\$30,303	\$102,569	\$258,864
Trumbull	\$195,575	\$30,303	\$61,695	\$287,573
Union	\$1,144	\$30,303	\$374	\$31,821
Vernon	\$101,722	\$30,303	\$80,067	\$212,092
Voluntown	\$6,180	\$30,303	\$2,924	\$39,407
Wallingford	\$150,871	\$30,303	\$60,569	\$241,742
Waterbury	\$630,012	\$30,303	\$781,845	\$1,442,160
Waterford	\$64,416	\$30,303	\$15,420	\$110,138
Watertown	\$76,497	\$30,303	\$35,975	\$142,775
West Hartford	\$265,480	\$30,303	\$77,043	\$372,826

Public School Operator	Need Student Portion of Grant	Flat Grant Portion of Grant	Wealth Portion of Grant	Total Grant
West Haven	\$190,423	\$30,303	\$169,355	\$390,081
Westbrook	\$16,856	\$30,303	\$3,397	\$50,556
Weston	\$54,040	\$30,303	\$4,483	\$88,826
Westport	\$141,020	\$30,303	\$5,765	\$177,087
Wethersfield	\$99,801	\$30,303	\$42,385	\$172,489
Willington	\$10,936	\$30,303	\$5,999	\$47,238
Wilton	\$100,863	\$30,303	\$8,783	\$139,949
Winchester	\$18,828	\$30,303	\$10,821	\$59,953
Windham	\$106,776	\$30,303	\$150,303	\$287,382
Windsor	\$99,712	\$30,303	\$36,928	\$166,944
Windsor Locks	\$44,810	\$30,303	\$17,126	\$92,239
Wolcott	\$59,341	\$30,303	\$34,309	\$123,953
Woodbridge	\$23,988	\$30,303	\$4,532	\$58,823
Woodstock	\$21,373	\$30,303	\$8,757	\$60,433

## Endnotes

---

<sup>1</sup> Eitland, E., Klingensmith, L., MacNaughton, P., Cedeno Laurent, J., Spengler, J., Bernstein, A., & Allen, J.G. (2017). *Foundations for Student Success: How School Buildings Influence Student Health, Thinking and Performance*. Boston, MA: Harvard T.H. Chan School of Public Health, Center for Health and the Global Environment. Retrieved from [https://forhealth.org/Harvard.Schools\\_For\\_Health.Foundations\\_for\\_Student\\_Success.pdf](https://forhealth.org/Harvard.Schools_For_Health.Foundations_for_Student_Success.pdf).

<sup>2</sup> Blagg, K, Terrones, F., & Nelson, V. (2023). *Assessing the National Landscape of Capital Expenditures for Public School Districts*. Washington, DC.: Urban Institute. Retrieved from <https://www.urban.org/sites/default/files/2023-01/Assessing%20the%20National%20Landscape%20of%20Capital%20Expenditures%20for%20Public%20School%20Districts.pdf>.

<sup>3</sup> Conn. Acts 25-174 § 131 (i).

<sup>4</sup> Conn. Acts 25-174 § 131 (b)(1).

<sup>5</sup> Ibid.

<sup>6</sup> Conn. Acts 25-174 § 131 (a)(1).

<sup>7</sup> Conn. Acts 25-174 § 131 (i).

<sup>8</sup> Conn. Acts 25-174 § 131 (c).

<sup>9</sup> Conn. Acts 25-174 §§ 131 (b)(1), (d)-(e).

<sup>10</sup> Conn. Acts 25-174 §§ 131 (a)(2), (b).

<sup>11</sup> Heft, M. L., Goupil, C., & Gallo, L. (2026, March 4). *District Repair and Improvement Project* [PowerPoint slides]. Hartford, CT: State of Connecticut, Office of Policy and Management. Retrieved from <https://portal.ct.gov/opm/-/media/opm/igpp/grants/drip/drip-presentation-342026.pdf>.

<sup>12</sup> Conn. Acts 25-174 §§ 131 (f)-(g).

<sup>13</sup> State of Connecticut, Office of Policy and Management. (2026). *FY 26 DRIP Program Grant Calculation*. Hartford, CT: Author. Retrieved from <https://portal.ct.gov/opm/-/media/opm/igpp/grants/drip/drip-fy26-calculation-published.pdf>.

**Minutes**  
**Financial, Facilities & Operations Committee**  
**May 15, 2026**

Present:

Michael Guido, Committee Chair

Deborah Low, Committee Member

Sharon Ferraro, Committee Member

Erica Forti, Superintendent of Schools

Phil Cross, Chief Finance and Operations Officer

Absent:

Mike DelMastro, Director of Facilities

The meeting was called to order by Mr. Guido at 9:01 a.m.

The Committee discussed the following regarding facilities and grounds maintenance:

- Mr. Cross reported that the District is continuing routine maintenance of all the buildings, and that seasonal temperature fluctuations have created some challenges regulating building temperatures. The transition to cooling is expected to begin the following week, and portable cooling units will be installed district-wide over the next two weeks in buildings without A/C. Mr. Cross added that the sidewalk project near Revson field is nearly complete, and work continues on the Lords Highway section. Additionally, initial work on the main entrance turning lane project has begun and is expected to be completed by early summer.
- Ms. Low referenced a parent concern regarding excessive heat in portions of the elementary school's North House classrooms. Mr. Cross reported that the North House HVAC project remains a district priority, with improvements expected to begin next summer. Additionally, he confirmed that all North House classrooms have portable units, with installation currently underway. The District will assess whether additional interim cooling measures are warranted.

The Committee discussed the following regarding the lower turf field replacement:

- Mr. Cross informed the Committee that regarding the FY27 capital project to replace the lower turf field, the District will utilize a purchasing consortium rather than a traditional standalone RFP. All participating vendors will attend a common walkthrough

and Q&A session before submitting bids. Contractors will be invited to a walk-thru by the end of May, with the contract being awarded by the end of July, and installation occurring in late August.

The Committee discussed the following regarding the educational specs for the North House HVAC Project:

- Mr. Cross reviewed the educational specifications for the North House HVAC project, and reported that the grant process requires that the specifications be created. The specs were created by Colliers, and Mr. Cross will bring them to the full Board for approval.
- Ms. Low requested that a brief summary of the specs be added for the Board, explaining why this HVAC approach was selected, the energy efficiency considerations, and why alternatives such as geothermal were not selected.

The Committee discussed the following regarding recent bid results:

- Mr. Cross informed the Committee that in April the Board went out to bid for three separate capital projects: WHS Locker Room Replacement of Heating Unit (FY26), HES Core Boiler & Pumps Replacement (FY26), HES East House Boiler Replacement and Piping (FY27). Based on the quoted prices, as well as reference checks, the WHS Locker Room Replacement project was awarded to Sav-More, and the HES Core Boiler & Pumps and HES East House Boiler Replacement were both awarded to Southport Contracting. The combined projects are projected to exceed budget by approximately \$21,000, but Mr. Cross will monitor other FY26 and FY27 capital projects for offsetting savings.

The Committee discussed the following regarding the FY26 monthly financial update (through April) including internal services:

- Mr. Cross reported that the District is currently projected to finish the year with a balanced budget. This is due in large part to the soft expenditure freeze that was implemented earlier this year. The current projected balance is \$19,095. While account balances will fluctuate for the remainder of the year, no major deferred spending concerns are anticipated going into the new fiscal year. Mr. Cross did note that rising custodial and maintenance supply costs may create future budget pressure due to vendor price increases.
- Mr. Cross identified upcoming needs for major auditorium upgrades at the high school, including replacement of the hoist control system, and electrical and sound system improvements. Mr. Cross will continue to evaluate the needs, and will keep the Board updated.

- Regarding the Internal Services Fund, Mr. Cross reported that he has not seen any unusual trend data.

The Committee discussed the following regarding the FY27 preschool tuition rates:

- Mr. Cross informed the Committee that the full rates for the integrated pre-school are established by the Pupil Services Department in collaboration with the Business Office. Periodically, the District compares tuition rates with other DRG A districts and local private pre-schools to ensure that the District's tuition remains competitive. Since this comparison was just made two years ago, Mr. Cross recommended that the FY27 Pre-K tuition for Weston residents' children without special needs be increased by \$1,000. This will increase the tuition rate to \$9,277 for FY27. Per Federal mandate, Weston residents with special needs are admitted to the program tuition free.
- The Committee agreed to move this recommendation forward to the full Board.

The Committee discussed the following regarding the FY27 tuition rates for non-residents:

- Mr. Cross reported that each year the District increases the non-resident tuition rates by that year's approved budget increase. He recommended that the FY26/27 tuition rate for non-resident students be increased by 3.07%.
- The Committee agreed to move this recommendation forward to the full Board.

The Committee discussed the following regarding the FY27 utility and user fees for facility rentals:

- Mr. Cross reported that each year the District increased the utility and user fees for facility rentals by that year's approved budget increase. He recommended that the FY26/27 utility and user fees be increased by the FY27 budget increase of 3.07%.
- The Committee agreed to move this recommendation forward to the full Board.

The Committee discussed the following regarding an FY27 Budget Update:

- Mr. Cross reviewed the revised FY27 capital budget formatting intended to better capture deferred projects and future planning. Ms. Low requested that future capital budgets also group projects by school. Mr. Guido presented a supplemental spreadsheet that offered additional analysis. Administration will consider incorporating this information into future budget materials.

- Mr. Cross reviewed anticipated DRIP (District Repair and Improvement Project) funding. The District is expected to receive approximately \$88,000 in FY26. The funding is intended for repairs and HVAC related issues. The Committee's discussion centered on whether funds should be reserved specifically for educational facilities needs versus reverting to the Town's general fund. Mr. Cross anticipates further discussion with the Board of Finance.

The Committee discussed the following regarding approval of the March minutes:

- The March minutes were approved without changes.

The Committee discussed the following regarding other business:

- Ms. Low informed the Committee that the upcoming Tri-Board middle school project meeting may need to be rescheduled due to coordination between the three participating boards.

There being no further business to discuss, the meeting adjourned at 9:52 a.m.

Respectfully submitted,

Andrew Galli

Administrative Assistant to the Chief Finance and Operations Officer