

**AGENDA OF RED OAK INDEPENDENT SCHOOL DISTRICT  
BOARD OF TRUSTEES REGULAR MEETING  
Monday, September 15, 2025**

Notice is hereby given that a Regular Meeting of the Board of Trustees of the Red Oak Independent School District will be held on Monday, September 15, 2025 beginning at 7:00 PM at Red Oak ISD Education Service Center, 109 West Red Oak Road, Red Oak, TX 75154.

The subjects to be discussed or considered, or upon which any formal action may be taken, are listed below. Items do not have to be taken in the same order as shown on the meeting notice.

1. CALL TO ORDER / ESTABLISH QUORUM
2. INVOCATION  
Jared Douglas, Lead Pastor of First Baptist Church Red Oak
3. PLEDGES OF ALLEGIANCE  
Isabelle Helms, 5th Grade Student from Eastridge Elementary School
4. SUPERINTENDENT'S REPORT
  - A. Safety Week Update  
Phillip Prasifka, Chief of Police, Red Oak ISD Police Department
  - B. District Update  
Brenda Sanford, Superintendent
5. OPEN FORUM 3
6. ACTION ITEMS
  - A. Consent Agenda
    1. Minutes from School Board Regular Meeting on August 25, 2025 5
    2. Payment of Current Bills Over \$50,000 10
    3. Prevailing Wage Rates 14
    4. Resolution for Student Transfer by Peace Officer 27
  - B. Consideration and Approval of Purchase of Cafeteria Equipment 29  
Victoria Ybarra, Director of Student Nutrition
  - C. Consideration and Approval of Resolution of Candidate Nominations 65  
for the Ellis Appraisal District Board of Directors for 2026  
Brenda Sanford, Superintendent
  - D. Consideration and Approval of School Library Advisory Committee 73  
(SLAC) for the 2025-2026 School Year  
Laura Kelly, Director of Instructional Technology
7. CLOSED SESSION
  - A. Texas Government Code 551.072 - For the purpose of discussing the purchase, exchange, lease or value of real property.
  - B. Texas Government Code 551.074 - For the purpose of considering the appointment, employment, evaluation, reassignment, duties, discipline or dismissal of a public officer or employee; or to hear a complaint or charge against an officer or employee.
    1. Personnel Matters
    2. Superintendent Goals
  - C. Texas Government Code 551.086 - For the purpose of considering economic development negotiations.
8. RECONVENE IN OPEN SESSION FOR ACTION RELATIVE TO CLOSED SESSION
9. ADJOURNMENT

***If, during the course of the meeting, discussion of any item on the agenda should be held in a closed meeting, the Board will convene in such closed meeting in accordance with the Open Meetings Act, Government Code, Chapter 551, Subchapters D and E. Before any closed meeting is convened, the presiding officer will publicly identify the section or sections of the Act authorizing the closed meeting. All final votes, actions or decisions will be taken in open meeting.***

Any person with a disability or special accommodation need should call 972-617-2941 no later than 10:00 a.m. on the scheduled meeting date.

This notice was posted in compliance with the Open Meetings Act on September 9, 2025 at 4:00 p.m.

---

Brenda Sanford, Superintendent  
(For the Board of Trustees)

## AUDIENCE PARTICIPATION SIGN-UP SHEET

Any person wishing to address the Board about a topic related to District business during the period reserved for public comment at a Board meeting must sign up to be heard, in accordance with District policy BED(LOCAL):

1. Each participant will be limited to two (2) minutes to make comments to the Board.
2. Under the Texas Open Meetings Act, the Board is not permitted to discuss or act upon any issues that are not posted on the agenda for tonight's meeting.
3. The Board has adopted complaint policies that are designed to secure, at the lowest possible administrative level, a prompt and equitable resolution of complaints and concerns. Each of these processes provides that, if a resolution cannot be achieved administratively, the person may appeal the administrative decision to the Board as a properly posted agenda item. For further information on those policies, please contact Cristi Watts, Executive Director of Student Services, for student issues, and Michelle Ailara, Deputy Superintendent, for employee issues at 972-617-2941. If the subject of your comment involves a pending grievance, please continue to seek resolution through the grievance process and address the Board only at the appropriate stage of that process.
4. Under the Texas Open Meetings Act, the Board may exercise its authority to discuss certain subject matters in closed session, including matters involving individual District staff members and individual students. If your comment concerns one of these subjects, please address your concern through the complaint policies described above.
5. Finally, please be aware that rules of decorum will be enforced during the public comment period. Personal attacks, name-calling, and rude or slanderous remarks will not be tolerated. Each participant is legally responsible for the content and consequences of his or her own statements.

Please fill in the information requested below if you wish to address the Board during the public comment period:

Name (please print) \_\_\_\_\_

Address \_\_\_\_\_

ROISD Campus Your Child(ren) attends \_\_\_\_\_

School District of Residence \_\_\_\_\_ Telephone \_\_\_\_\_

Topic/ Agenda Item \_\_\_\_\_

**Limit on Participation**

Audience participation at a Board meeting is limited to the portion of the meeting designated to receive public comment in accordance with this policy. At all other times during a Board meeting, the audience shall not enter into discussion or debate on matters being considered by the Board, unless requested by the presiding officer.

**Public Comment**

**Regular Meetings**

At regular Board meetings, the Board shall permit public comment, regardless of whether the topic is an item on the agenda posted with notice of the meeting.

**Special Meetings**

At all other Board meetings, public comment shall be limited to items on the agenda posted with notice of the meeting.

**Procedures**

Individuals who wish to participate during the portion of the meeting designated for public comment shall sign up with the presiding officer or designee before the meeting begins as specified in the Board's procedures on public comment and shall indicate the agenda item or topic on which they wish to address the Board.

Public comment shall occur at the beginning of the meeting.

Except as permitted by this policy and the Board's procedures on public comment, an individual's comments to the Board shall not exceed two minutes per meeting.

**Meeting Management**

When necessary for effective meeting management or to accommodate large numbers of individuals wishing to address the Board, the presiding officer may make adjustments to public comment procedures, including adjusting when public comment will occur during the meeting, reordering agenda items, deferring public comment on nonagenda items, continuing agenda items to a later meeting, providing expanded opportunity for public comment, or establishing an overall time limit for public comment and adjusting the time allotted to each speaker. However, no individual shall be given less than one minute to make comments.

**Board's Response**

Specific factual information or recitation of existing policy may be furnished in response to inquiries, but the Board shall not deliberate or decide regarding any subject that is not included on the agenda posted with notice of the meeting.

**Complaints and Concerns**

The presiding officer or designee shall determine whether an individual addressing the Board has attempted to solve a matter administratively through resolution channels established by policy. If not, the individual shall be referred to the appropriate policy to seek resolution:

- Employee complaints: DGBA
- Student or parent complaints: FNG
- Public complaints: GF

**Disruption**

The Board shall not tolerate disruption of the meeting by members of the audience. If, after at least one warning from the presiding officer, any individual continues to disrupt the meeting by his or her words or actions, the presiding officer may request assistance from law enforcement officials to have the individual removed from the meeting.

**MINUTES OF THE  
RED OAK INDEPENDENT SCHOOL DISTRICT  
BOARD OF TRUSTEES REGULAR MEETING  
Monday, August 25, 2025**

A Regular Meeting of the Board of Trustees of Red Oak ISD was held Monday, August 25, 2025, beginning at 7:00 PM at the Red Oak ISD Education Service Center, 109 West Red Oak Road, Red Oak, TX 75154.

1. CALL TO ORDER / ESTABLISH QUORUM

The Regular Meeting of the School Board was called to order by Melanie Petersen, President of the School Board, at 7:00 p.m.

The Red Oak ISD School Board met at the Red Oak ISD Education Service Center and the presiding officer, Melanie Petersen, noted that a quorum of Board Members was present; that the meeting was duly called; and that notice of the meeting had been posted in accordance with the Texas Open Meetings Act, Texas Government Code, Chapter 551.00.

The following Board members were present: Melanie Petersen, President; Johnny Knight, Vice President; Sean Kelly, Secretary; John Anderson; Donna Knight; Donny Lutrick; and Brian Sebring.

The following Board members were absent: None.

2. INVOCATION

Mr. Knight led the invocation.

3. PLEDGES OF ALLEGIANCE

Mr. Sebring led the Pledges of Allegiance to the American and Texas flags.

4. SUPERINTENDENT'S REPORT

A. Construction Update

Brent Stanford, Executive Director of Support Services

**Mr. Stanford, Executive Director of Support Services, gave the Board an update on the progress of Dr. Joy Shaw Middle School.**

B. Accountability Update

Megan Corns, Chief Technology Officer and Michelle Owen, Chief Academic Officer

**Ms. Corns, Chief Technology Officer, gave an Accountability Update that included: Assessment; Accountability; Accountability Domains; Campus Ratings and Comparison; Distinctions; Celebrations; Areas of Opportunity; and Next Steps.**

- C. District Update  
Brenda Sanford, Superintendent

**Mrs. Sanford gave the Board upcoming dates.**

5. OPEN FORUM

**The following individuals spoke in Open Forum – Christy Kelso regarding Shaw Middle School and Laura Cheek regarding safety concerns at Red Oak High School.**

6. ACTION ITEMS

A. Consent Agenda

1. Minutes from School Board Regular Meeting on July 21, 2025
2. Minutes from School Board Special Meeting on July 29, 2025 - 4:00 p.m.
3. Minutes from School Board Special Meeting on July 29, 2025 - 5:00 p.m.
4. Payment of Current Bills Over \$50,000
5. Chromebook Device Replacement

**This item was pulled from the Consent Agenda and discussed separately. Mr. Anderson made a motion to approve the lease of Chromebooks from Delcom through Financial Services for a total of \$666,654.00, using Choice Partners contract #22/043KN-07. Mr. Sebring seconded the motion. The motion passed 6 – 1 with Mr. Kelly voting “no”.**

6. District of Innovation Plan Amendment
7. Purchase of Interactive Flat Panels for Red Oak Middle School
8. Purchase of Weapons Detection Systems for Goodloe Stadium and Athletic Venues
9. Purchase of Strong Foundations Math Program
10. T-TESS Appraiser List for 2025-2026

**Mr. Sebring made a motion to approve the Consent Agenda as presented with the exception of item number 5. Ms. Knight seconded the motion. The motion passed 7 – 0.**

- B. Consideration and Approval of 2025 Tax Rate and Resolution Setting Tax Rate  
Dr. Bill Johnston, Chief Financial Officer

**Mr. Knight made a motion that the property tax rate be increased by the adoption of a tax rate of \$1.0633, which is effectively a 15.65% increase in the Maintenance and Operation tax rate. Mr. Kelly seconded the motion. The motion passed 7 – 0.**

- C. Consideration and Approval of 2025-2026 Fiscal Year Amended Budget  
Dr. Bill Johnston, Chief Financial Officer

**Mr. Sebring made a motion to approve the Amended 2025-2026 Fiscal Year Budget and Appendix for the General Operating Fund, Student Nutrition Fund and Debt Service Fund as presented. Mr. Knight seconded the motion. The motion passed 7 – 0.**

- D. Consideration and Approval of Assignment of Fund Balance and Resolution for 2025-2026  
Dr. Bill Johnston, Chief Financial Officer

**Mr. Knight made a motion to approve the transfer of funds from Undesignated (3600) to Assigned (3590) Fund Balance for potential residential placement. Mr. Sebring seconded the motion. The motion passed 7 – 0.**

- E. Consideration and Approval of Construction Manager At-Risk for 2025 Bond Projects  
Brenda Sanford, Superintendent

**Mr. Knight made a motion to authorize the Superintendent to negotiate and enter into a contract with Joeris General Contractors for performing pre-construction services to establish a Guaranteed Maximum Price (GMP) and further continue through the general construction of the projects, should the GMP fit within the budget allowed. Mr. Sebring seconded the motion. The motion passed 7 – 0.**

- F. Consideration and Approval of Purchase of School Bus from the 2025-2026 Budget  
Brent Stanford, Executive Director of Support Services

**Mr. Kelly made a motion to approve the purchase of one (1) special needs bus with lift gate and the appropriate three-point seat belts from the 2025-2026 budget year from Longhorn Bus Sales, using Buyboard contract 722-23. Ms. Knight seconded the motion. The motion passed 7 – 0.**

- G. Consideration and Approval of Turf Installation for ROHS Baseball and Softball Fields  
Brent Stanford, Executive Director of Support Services

**Mr. Knight made a motion to purchase turf replacement as detailed in the proposal submitted by Hellas Construction, in the amount of \$3,630,240, using**

**1GPA (1 Government Procurement Alliance) contract #23-01DP-03 Athletic Surfaces, Appurtenances & Minor Structures and Contract #24-06DP-04 JOC General Construction. Mr. Kelly seconded the motion. The motion passed 7 – 0.**

7. INFORMATION ITEMS

- A. UIL "No Pass, No Play" Exemptions

8. CLOSED SESSION

**The Board convened into Closed Session at 8:35 p.m.**

- A. Texas Government Code 551.071 - For the purpose of a private consultation with the Board's attorney on any and all subjects or matters authorized by law.
- B. Texas Government Code 551.072 - For the purpose of discussing the purchase, exchange, lease or value of real property.
- C. Texas Government Code 551.073 - For the purpose of considering a negotiated contract for a prospective gift or donation.
- D. Texas Government Code 551.074 - For the purpose of considering the appointment, employment, evaluation, reassignment, duties, discipline or dismissal of a public officer or employee; or to hear a complaint or charge against an officer or employee.
  - 1. Personnel Matters
- E. Texas Government Code 551.076 - To consider the deployment, or specific occasions for implementation, of security personnel or devices.
- F. Texas Government Code 551.082 - For the purpose of considering discipline of a public school child or children or to hear a complaint by an employee against another employee if the complaint or charge directly results in a need for a hearing.
- G. Texas Government Code 551.0821 - Personally identifiable information of Public School students.
- H. Texas Government Code 551.083 - For the purpose of considering the standards, guidelines, terms or conditions the Board will follow, or instruct its representatives to follow, in consultation with representative of employee groups in connection with consultation agreements provided for by Section 13.901 of the Texas Education Code.
- I. Texas Government Code 551.084 - For the purpose of excluding witness or witnesses from a hearing during examination of another witness.
- J. Texas Government Code 551.086 - For the purpose of considering economic development negotiations.

9. RECONVENE IN OPEN SESSION FOR ACTION RELATIVE TO CLOSED SESSION

**The Board reconvened back into Open Session at 10:00 p.m.**

10. ADJOURNMENT

**As there was no further business or action to be taken, the meeting adjourned at 10:00 p.m.**

---

Melanie Petersen, Board President

---

Sean Kelly, Board Secretary

CHECK		ACCOUNT	
NUMBER	VENDOR	AMOUNT	NUMBER
232981	INSTRUCTURE, INC.	60,740.03	199 E 11 6398 00 871 0 11 000
		60,740.03	Totals for 232981
233018	YONDR INC	63,165.60	199 E 11 6639 00 999 0 11 000
233018	YONDR INC	46,847.20	199 E 11 6639 00 999 0 11 000
		110,012.80	Totals for 233018
233215	CDWG	59.21	199 E 12 6396 00 042 0 99 000
233215	CDWG	51,699.47	199 E 53 6398 00 997 0 99 000
233215	CDWG	1,161.00	199 E 53 6396 00 997 0 99 000
		52,919.68	Totals for 233215
233250	SAVVAS LEARNING COMP	74,143.60	410 E 11 6321 26 999 0 11 IMA
		74,143.60	Totals for 233250
		297,816.11	Totals for checks

CHECK		ACCOUNT					
NUMBER	VENDOR	AMOUNT	NUMBER				
19618	LABATT FOOD SERVICE	9,317.41	240 E 35 6341 00 001 0 99 000				
19618	LABATT FOOD SERVICE	1,971.23	240 E 35 6342 00 001 0 99 000				
19618	LABATT FOOD SERVICE	1,980.48	240 E 35 6341 00 001 0 99 000				
19618	LABATT FOOD SERVICE	545.88	240 E 35 6341 00 041 0 99 000				
19618	LABATT FOOD SERVICE	6,558.32	240 E 35 6341 00 041 0 99 000				
19618	LABATT FOOD SERVICE	4,032.79	240 E 35 6341 00 041 0 99 000				
19618	LABATT FOOD SERVICE	5,093.34	240 E 35 6341 00 101 0 99 000				
19618	LABATT FOOD SERVICE	5,880.48	240 E 35 6341 00 102 0 99 000				
19618	LABATT FOOD SERVICE	4,613.66	240 E 35 6341 00 103 0 99 000				
19618	LABATT FOOD SERVICE	257.47	240 E 35 6342 00 103 0 99 000				
19618	LABATT FOOD SERVICE	5,255.22	240 E 35 6341 00 105 0 99 000				
19618	LABATT FOOD SERVICE	327.12	240 E 35 6342 00 105 0 99 000				
19618	LABATT FOOD SERVICE	5,155.97	240 E 35 6341 00 107 0 99 000				
19618	LABATT FOOD SERVICE	80.63	240 E 35 6341 00 999 0 99 000				
19618	LABATT FOOD SERVICE	1,344.96	240 E 35 6341 00 999 0 99 000				
		52,414.96	Totals for 19618				

52,414.96 Totals for checks

CHECK		ACCOUNT	
NUMBER	VENDOR	AMOUNT	NUMBER
12255	FOLLETT CONTENT SOLU	167,443.89	650 E 81 6629 00 999 0 99 FFE
		167,443.89	Totals for 12255
12256	MIDWEST SPORTING GOO	23,040.00	650 E 81 6629 00 999 0 99 FFE
12256	MIDWEST SPORTING GOO	13,373.75	650 E 81 6629 00 999 0 99 FFE
12256	MIDWEST SPORTING GOO	20,100.00	650 E 81 6629 00 999 0 99 FFE
		56,513.75	Totals for 12256
12264	DELCOM GROUP LP	93,498.48	650 E 81 6629 00 999 0 99 FFE
12264	DELCOM GROUP LP	566,506.14	650 E 81 6629 00 999 0 99 FFE
		660,004.62	Totals for 12264
12265	JOERIS GENERAL CONTR	5,904,307.95	650 E 81 6629 00 999 0 99 000
		5,904,307.95	Totals for 12265
12266	JOERIS GENERAL CONTR	3,609,247.75	650 E 81 6629 00 999 0 99 000
		3,609,247.75	Totals for 12266
12269	OCOP EXPRESS/DBA	127,230.29	650 E 81 6629 00 999 0 99 FFE
		127,230.29	Totals for 12269
12271	RUSSELL BYRUM SIGNS,	4,570.00	699 E 51 6629 34 999 0 99 000
12271	RUSSELL BYRUM SIGNS,	68,663.40	699 E 51 6639 34 999 0 99 000
		73,233.40	Totals for 12271
12272	TENNANT SALES & SERV	26,885.95	650 E 81 6629 00 999 0 99 FFE
12272	TENNANT SALES & SERV	26,966.70	650 E 81 6629 00 999 0 99 FFE
		53,852.65	Totals for 12272
12274	WENGER CORPORATION	68,640.42	650 E 81 6629 00 999 0 99 FFE
		68,640.42	Totals for 12274
12277	COMMUNICATIONS TECHN	89,807.40	650 E 81 6629 00 999 0 99 FFE
		89,807.40	Totals for 12277
12280	KLC VIDEO SECURITY/D	419,495.00	650 E 81 6629 00 999 0 99 000
		419,495.00	Totals for 12280
12281	MIDWEST SPORTING GOO	9,056.00	650 E 81 6629 00 999 0 99 FFE
12281	MIDWEST SPORTING GOO	80,518.60	650 E 81 6629 00 999 0 99 FFE
		89,574.60	Totals for 12281
12290	CORGAN ASSOCIATES IN	60,000.00	650 E 81 6629 00 999 0 99 000
		60,000.00	Totals for 12290
12291	JOERIS GENERAL CONTR	1,425,000.00	650 E 81 6629 00 999 0 99 000
		1,425,000.00	Totals for 12291
12292	JOERIS GENERAL CONTR	75,000.00	650 E 81 6629 00 999 0 99 000
		75,000.00	Totals for 12292
12294	SUPERIOR FIBER & DAT	83,541.56	650 E 81 6629 00 999 0 99 000
		83,541.56	Totals for 12294
12295	TFE/DBA	6,743.99	650 E 81 6629 00 999 0 99 FFE
12295	TFE/DBA	57,774.24	650 E 81 6629 00 999 0 99 FFE

CHECK		ACCOUNT	
NUMBER	VENDOR	AMOUNT	NUMBER
		64,518.23	Totals for 12295
12296	UNITED DATA TECHNOLO	10,180.00	650 E 81 6629 00 999 0 99 000
12296	UNITED DATA TECHNOLO	57,947.60	650 E 81 6629 00 999 0 99 000
		68,127.60	Totals for 12296
12308	CORGAN ASSOCIATES IN	10,800.00	656 E 81 6629 00 999 0 99 000
12308	CORGAN ASSOCIATES IN	23,400.00	651 E 81 6629 00 999 0 99 000
12308	CORGAN ASSOCIATES IN	61,510.00	654 E 81 6629 00 999 0 99 000
12308	CORGAN ASSOCIATES IN	31,185.00	658 E 81 6629 00 999 0 99 000
12308	CORGAN ASSOCIATES IN	34,200.00	652 E 81 6629 00 999 0 99 000
		161,095.00	Totals for 12308
12312	TFE/DBA	78,709.45	650 E 81 6629 00 999 0 99 FFE
12312	TFE/DBA	6,743.99	650 E 81 6629 00 999 0 99 FFE
		85,453.44	Totals for 12312
12313	TFE/DBA	78,709.45	650 E 81 6629 00 999 0 99 FFE
12313	TFE/DBA	6,743.99	650 E 81 6629 00 999 0 99 FFE
		85,453.44	Totals for 12313
		13,427,540.99	Totals for checks



## Prevailing Wage Rate Determination Information

*The following information is from Chapter 2258 Texas Government Code:*

### **2258.021. Right to be Paid Prevailing Wage Rates.**

- (a) A worker employed on a public work by or on behalf of the state or a political subdivision of the state shall be paid:
  - (1) not less than the general prevailing rate of per diem wages for work of a similar character in the locality in which the work is performed; and
  - (2) not less than the general prevailing rate of per diem wages for legal holiday and overtime work.
- (b) Subsection (a) does not apply to maintenance work.
- (c) A worker is employed on a public work for the purposes of this section if the worker is employed by a contractor or subcontractor in the execution of a contract for the public work with the state, a political subdivision of the state, or any officer or public body of the state or a political subdivision of the state.

### **2258.023. Prevailing Wage Rates to be Paid by Contractor and Subcontractor; Penalty.**

- (a) The contractor who is awarded a contract by a public body or a subcontractor of the contractor shall pay not less than the rates determined under Section 2258.022 to a worker employed by it in the execution of the contract.
- (b) A contractor or subcontractor who violates this section shall pay to the state or a political subdivision of the state on whose behalf the contract is made, \$60 for each worker employed for each calendar day or part of the day that the worker is paid less than the wage rates stipulated in the contract. A public body awarding a contract shall specify this penalty in the contract.
- (c) A contractor or subcontractor does not violate this section if a public body awarding a contract does not determine the prevailing wage rates and specify the rates in the contract as provided by Section 2258.022.
- (d) The public body shall use any money collected under this section to offset the costs incurred in the administration of this chapter.
- (e) A municipality is entitled to collect a penalty under this section only if the municipality has a population of more than 10,000.

### **2258.051. Duty of Public Body to Hear Complaints and Withhold Payment.**

A public body awarding a contract, and an agent or officer of the public body, shall:

- (1) take cognizance of complaints of all violations of this chapter committed in the execution of the contract; and
- (2) withhold money forfeited or required to be withheld under this chapter from the payments to the contractor under the contract, except that the public body may not withhold money from other than the final payment without a determination by the public body that there is good cause to believe that the contractor has violated this chapter.

"General Decision Number: TX20250246 07/18/2025

Superseded General Decision Number: TX20240246

State: Texas

Construction Type: Building

County: Ellis County in Texas.

BUILDING CONSTRUCTION PROJECTS (does not include single family homes or apartments up to and including 4 stories).

Note: Contracts subject to the Davis-Bacon Act are generally required to pay at least the applicable minimum wage rate required under Executive Order 14026 or Executive Order 13658. Please note that these Executive Orders apply to covered contracts entered into by the federal government that are subject to the Davis-Bacon Act itself, but do not apply to contracts subject only to the Davis-Bacon Related Acts, including those set forth at 29 CFR 5.1(a)(1).

If the contract is entered into on or after January 30, 2022, or the contract is renewed or extended (e.g., an option is exercised) on or after January 30, 2022:	. Executive Order 14026 generally applies to the contract. . The contractor must pay all covered workers at least \$17.75 per hour (or the applicable wage rate listed on this wage determination, if it is higher) for all hours spent performing on the contract in 2025.
If the contract was awarded on or between January 1, 2015 and January 29, 2022, and the contract is not renewed or extended on or after January 30, 2022:	. Executive Order 13658 generally applies to the contract. . The contractor must pay all covered workers at least \$13.30 per hour (or the applicable wage rate listed on this wage determination, if it is higher) for all hours spent performing on that contract in 2025.

The applicable Executive Order minimum wage rate will be

adjusted annually. If this contract is covered by one of the Executive Orders and a classification considered necessary for performance of work on the contract does not appear on this wage determination, the contractor must still submit a conformance request.

Additional information on contractor requirements and worker protections under the Executive Orders is available at <http://www.dol.gov/whd/govcontracts>.

Modification Number	Publication Date
0	01/03/2025
1	03/14/2025
2	07/04/2025
3	07/18/2025

ASBE0021-011 06/01/2025

	Rates	Fringes
ASBESTOS WORKER/HEAT & FROST INSULATOR (Duct, Pipe and Mechanical System Insulation)....	\$ 33.23	7.52

-----  
BOIL0074-003 01/01/2025

	Rates	Fringes
BOILERMAKER.....	\$ 33.17	24.92

-----  
CARP1421-002 10/01/2023

	Rates	Fringes
MILLWRIGHT.....	\$ 32.02	11.27

-----  
ELEV0021-006 01/01/2025

	Rates	Fringes
ELEVATOR MECHANIC.....	\$ 51.93	38.435+a+b

FOOTNOTES:

A. 6% under 5 years based on regular hourly rate for all hours worked. 8% over 5 years based on regular hourly rate for all hours worked.

B. New Year's Day, Memorial Day, Independence Day, Labor Day, Thanksgiving Day, the Friday after Thanksgiving Day,

Christmas Day, and Veterans Day.

-----  
ENGI0178-005 06/01/2020

	Rates	Fringes
POWER EQUIPMENT OPERATOR		
(1) Tower Crane.....	\$ 32.85	13.10
(2) Cranes with Pile Driving or Caisson Attachment and Hydraulic Crane 60 tons and above.....	\$ 28.75	10.60
(3) Hydraulic cranes 59 Tons and under.....	\$ 32.35	13.10

-----  
\* IRON0263-005 06/01/2025

	Rates	Fringes
IRONWORKER (ORNAMENTAL AND STRUCTURAL).....	\$ 29.64	8.43

-----  
PLUM0100-005 11/01/2024

	Rates	Fringes
HVAC MECHANIC (HVAC Unit Installation Only).....	\$ 39.76	14.04
PIPEFITTER (Excludes HVAC Pipe Installation).....	\$ 39.76	14.04

-----  
\* SUTX2014-022 07/21/2014

	Rates	Fringes
BRICKLAYER.....	\$ 19.89	0.00
CARPENTER, Excludes Drywall Hanging, Form Work, and Metal Stud Installation.....	\$ 16.62 **	0.00
CAULKER.....	\$ 15.16 **	0.00
CEMENT MASON/CONCRETE FINISHER...	\$ 13.21 **	0.00
DRYWALL HANGER AND METAL STUD INSTALLER.....	\$ 15.42 **	0.00

ELECTRICIAN (Alarm

Installation Only).....	\$ 20.93	3.86
ELECTRICIAN (Communication Technician Only).....	\$ 17.62 **	2.92
ELECTRICIAN (Low Voltage Wiring Only).....	\$ 17.97	2.63
ELECTRICIAN, Excludes Low Voltage Wiring and Installation of Alarms/Sound and Communication Systems.....	\$ 20.65	3.05
FORM WORKER.....	\$ 12.13 **	0.00
GLAZIER.....	\$ 16.55 **	3.13
HIGHWAY/PARKING LOT STRIPING: Operator (Striping Machine).....	\$ 10.04 **	2.31
INSTALLER - SIDING (METAL/ALUMINUM/VINYL).....	\$ 14.74 **	0.00
INSTALLER - SIGN.....	\$ 15.61 **	0.00
INSULATOR - BATT.....	\$ 13.00 **	0.00
IRONWORKER, REINFORCING.....	\$ 12.37 **	0.00
LABORER: Common or General.....	\$ 12.97 **	0.00
LABORER: Mason Tender - Brick...	\$ 10.54 **	0.00
LABORER: Mason Tender - Cement/Concrete.....	\$ 10.75 **	0.00
LABORER: Pipelayer.....	\$ 13.00 **	0.35
LABORER: Plaster Tender.....	\$ 12.22 **	0.00
LABORER: Roof Tearoff.....	\$ 11.28 **	0.00
LABORER: Landscape and Irrigation.....	\$ 11.09 **	0.00
LATHER.....	\$ 16.00 **	0.00
OPERATOR: Backhoe/Excavator/Trackhoe.....	\$ 12.83 **	0.00

OPERATOR: Bobcat/Skid Steer/Skid Loader.....	\$ 13.93 **	0.00
OPERATOR: Bulldozer.....	\$ 18.29	1.31
OPERATOR: Drill.....	\$ 15.69 **	0.50
OPERATOR: Forklift.....	\$ 13.21 **	0.81
OPERATOR: Grader/Blade.....	\$ 12.96 **	0.00
OPERATOR: Loader.....	\$ 13.46 **	0.85
OPERATOR: Mechanic.....	\$ 17.52 **	3.33
OPERATOR: Paver (Asphalt, Aggregate, and Concrete).....	\$ 18.44	0.00
OPERATOR: Roller.....	\$ 15.04 **	0.00
PAINTER (Brush, Roller and Spray), Excludes Drywall Finishing/Taping.....	\$ 13.21 **	2.33
PAINTER: Drywall Finishing/Taping Only.....	\$ 13.76 **	2.84
PLASTERER.....	\$ 15.75 **	0.00
PLUMBER (HVAC Pipe Installation Only).....	\$ 22.16	5.46
PLUMBER, Excludes HVAC Pipe Installation.....	\$ 22.31	5.18
ROOFER.....	\$ 17.19 **	0.00
SHEET METAL WORKER (HVAC Duct Installation Only).....	\$ 20.88	5.19
SHEET METAL WORKER, Excludes HVAC Duct Installation.....	\$ 24.88	5.97
SPRINKLER FITTER (Fire Sprinklers).....	\$ 22.94	0.00
TILE FINISHER.....	\$ 11.22 **	0.00
TILE SETTER.....	\$ 14.25 **	0.00

TRUCK DRIVER: 1/Single Axle Truck.....	\$ 16.40 **	0.81
TRUCK DRIVER: Dump Truck.....	\$ 12.39 **	1.18
TRUCK DRIVER: Flatbed Truck.....	\$ 19.65	8.57
TRUCK DRIVER: Semi-Trailer Truck.....	\$ 12.50 **	0.00
TRUCK DRIVER: Water Truck.....	\$ 12.00 **	4.11
TRUCK DRIVER.....	\$ 16.15 **	3.46

-----  
WELDERS - Receive rate prescribed for craft performing operation to which welding is incidental.

=====  
\*\* Workers in this classification may be entitled to a higher minimum wage under Executive Order 14026 (\$17.75) or 13658 (\$13.30). Please see the Note at the top of the wage determination for more information. Please also note that the minimum wage requirements of Executive Order 14026 are not currently being enforced as to any contract or subcontract to which the states of Texas, Louisiana, or Mississippi, including their agencies, are a party.

Note: Executive Order (EO) 13706, Establishing Paid Sick Leave for Federal Contractors applies to all contracts subject to the Davis-Bacon Act for which the contract is awarded (and any solicitation was issued) on or after January 1, 2017. If this contract is covered by the EO, the contractor must provide employees with 1 hour of paid sick leave for every 30 hours they work, up to 56 hours of paid sick leave each year. Employees must be permitted to use paid sick leave for their own illness, injury or other health-related needs, including preventive care; to assist a family member (or person who is like family to the employee) who is ill, injured, or has other health-related needs, including preventive care; or for reasons resulting from, or to assist a family member (or person who is like family to the employee) who is a victim of, domestic violence, sexual assault, or stalking. Additional information on contractor requirements and worker protections under the EO is available at <https://www.dol.gov/agencies/whd/government-contracts>.

Unlisted classifications needed for work not included within the scope of the classifications listed may be added after

award only as provided in the labor standards contract clauses (29CFR 5.5 (a) (1) (iii)).

-----

The body of each wage determination lists the classifications and wage rates that have been found to be prevailing for the type(s) of construction and geographic area covered by the wage determination. The classifications are listed in alphabetical order under rate identifiers indicating whether the particular rate is a union rate (current union negotiated rate), a survey rate, a weighted union average rate, a state adopted rate, or a supplemental classification rate.

#### Union Rate Identifiers

A four-letter identifier beginning with characters other than "SU", "UAVG", "SA", or "SC" denotes that a union rate was prevailing for that classification in the survey. Example: PLUM0198-005 07/01/2024. PLUM is an identifier of the union whose collectively bargained rate prevailed in the survey for this classification, which in this example would be Plumbers. 0198 indicates the local union number or district council number where applicable, i.e., Plumbers Local 0198. The next number, 005 in the example, is an internal number used in processing the wage determination. The date, 07/01/2024 in the example, is the effective date of the most current negotiated rate.

Union prevailing wage rates are updated to reflect all changes over time that are reported to WHD in the rates in the collective bargaining agreement (CBA) governing the classification.

#### Union Average Rate Identifiers

The UAVG identifier indicates that no single rate prevailed for those classifications, but that 100% of the data reported for the classifications reflected union rates. EXAMPLE: UAVG-OH-0010 01/01/2024. UAVG indicates that the rate is a weighted union average rate. OH indicates the State of Ohio. The next number, 0010 in the example, is an internal number used in producing the wage determination. The date, 01/01/2024 in the example, indicates the date the wage determination was updated to reflect the most current union average rate.

A UAVG rate will be updated once a year, usually in January, to reflect a weighted average of the current rates in the collective bargaining agreements on which the rate is based.

## Survey Rate Identifiers

The ""SU"" identifier indicates that either a single non-union rate prevailed (as defined in 29 CFR 1.2) for this classification in the survey or that the rate was derived by computing a weighted average rate based on all the rates reported in the survey for that classification. As a weighted average rate includes all rates reported in the survey, it may include both union and non-union rates. Example: SUFL2022-007 6/27/2024. SU indicates the rate is a single non-union prevailing rate or a weighted average of survey data for that classification. FL indicates the State of Florida. 2022 is the year of the survey on which these classifications and rates are based. The next number, 007 in the example, is an internal number used in producing the wage determination. The date, 6/27/2024 in the example, indicates the survey completion date for the classifications and rates under that identifier.

?SU? wage rates typically remain in effect until a new survey is conducted. However, the Wage and Hour Division (WHD) has the discretion to update such rates under 29 CFR 1.6(c)(1).

## State Adopted Rate Identifiers

The ""SA"" identifier indicates that the classifications and prevailing wage rates set by a state (or local) government were adopted under 29 C.F.R 1.3(g)-(h). Example: SAME2023-007 01/03/2024. SA reflects that the rates are state adopted. ME refers to the State of Maine. 2023 is the year during which the state completed the survey on which the listed classifications and rates are based. The next number, 007 in the example, is an internal number used in producing the wage determination. The date, 01/03/2024 in the example, reflects the date on which the classifications and rates under the ?SA? identifier took effect under state law in the state from which the rates were adopted.

-----  

## WAGE DETERMINATION APPEALS PROCESS

1) Has there been an initial decision in the matter? This can be:

- a) a survey underlying a wage determination
- b) an existing published wage determination
- c) an initial WHD letter setting forth a position on a wage determination matter
- d) an initial conformance (additional classification

and rate) determination

On survey related matters, initial contact, including requests for summaries of surveys, should be directed to the WHD Branch of Wage Surveys. Requests can be submitted via email to [davisbaconinfo@dol.gov](mailto:davisbaconinfo@dol.gov) or by mail to:

Branch of Wage Surveys  
Wage and Hour Division  
U.S. Department of Labor  
200 Constitution Avenue, N.W.  
Washington, DC 20210

Regarding any other wage determination matter such as conformance decisions, requests for initial decisions should be directed to the WHD Branch of Construction Wage Determinations. Requests can be submitted via email to [BCWD-Office@dol.gov](mailto:BCWD-Office@dol.gov) or by mail to:

Branch of Construction Wage Determinations  
Wage and Hour Division  
U.S. Department of Labor  
200 Constitution Avenue, N.W.  
Washington, DC 20210

2) If an initial decision has been issued, then any interested party (those affected by the action) that disagrees with the decision can request review and reconsideration from the Wage and Hour Administrator (See 29 CFR Part 1.8 and 29 CFR Part 7). Requests for review and reconsideration can be submitted via email to [dba.reconsideration@dol.gov](mailto:dba.reconsideration@dol.gov) or by mail to:

Wage and Hour Administrator  
U.S. Department of Labor  
200 Constitution Avenue, N.W.  
Washington, DC 20210

The request should be accompanied by a full statement of the interested party's position and any information (wage payment data, project description, area practice material, etc.) that the requestor considers relevant to the issue.

3) If the decision of the Administrator is not favorable, an interested party may appeal directly to the Administrative Review Board (formerly the Wage Appeals Board). Write to:

Administrative Review Board  
U.S. Department of Labor  
200 Constitution Avenue, N.W.  
Washington, DC 20210.

=====

END OF GENERAL DECISION"

**Resolution to Adopt a Prevailing Wage Rate for 2025-2028**

**Red Oak Independent School District**

**September 15, 2025**

On this date, September 15, 2025, we, the School Board of Red Oak Independent School District, hereby adopt the prevailing wage rates (Exhibit A) as determined by the United States Department of Labor in accordance with the Davis-Bacon Act for Ellis County, and subsequent amendments, as the minimum rates for each project type that shall be used for all contractors and subcontracts on construction projects by or on behalf of the District.

A contractor or subcontractor shall maintain records as required by Chapter 2258 and shall be subject to the penalties, forfeitures, and withholding of money for failure to comply with this Resolution and/or pending a final determination of an alleged violation, as provided in Chapter 2258. The hourly rates for overtime work and legal holidays shall be one and one-half times the basic Davis-Bacon hourly wage rate.

The Superintendent is hereby directed and authorized to specify the wage rates adopted hereunder for each project type in all specifications for bids and contracts for construction projects by or on behalf of the District.

Any prior Resolution Adopting Prevailing Wage Rate Scale for Construction Projects previously adopted by the Board is hereby revoked.

IN CERTIFICATION THEREOF:

\_\_\_\_\_  
Melanie Petersen, Board President  
Red Oak Independent School District

ATTEST:

\_\_\_\_\_  
Sean Kelly, Board Secretary  
Red Oak Independent School District

Resolution for Student Transfer by Peace Officer

**Presented for:**

Board Action   X   Report/Review Only \_\_\_\_\_

**Supporting documents:**

None \_\_\_\_\_ Attached   X   Provided Later \_\_\_\_\_

**Contact Person:**

Megan Corns, Chief Technology Officer

**Background Information:**

Effective September 1, 2023, H.B. 1959 enacted a bill to allow a peace officer who is a parent of a student to request a student transfer to another school district under an agreement under Section 25.035.

Board Policy FDA and Texas Education Code Section 25.035 states “the boards of trustees of two or more adjoining school districts by agreement may transfer a student from the jurisdiction of one board to that of another. And the participating governing boards shall also agree to the transfer of school funds or other payments proportionate to the transfer of attendance.”

Ferris ISD’s Board of Trustees approved this transfer on August 19, 2025.

**Fiscal Implications:**

Red Oak ISD is not required to provide transportation to a transfer student.

**Administrative Recommendation:**

The Administration recommends approval of the Resolution for Student Transfer by Peace Officer as presented.

**RED OAK INDEPENDENT SCHOOL DISTRICT**

**RESOLUTION OF THE BOARD REGARDING REQUEST FOR STUDENT  
TRANSFER BY PEACE OFFICER**

WHEREAS, the Red Oak Independent School District (“Red Oak ISD” or “District”) Board of Trustees (“Board”) intends to comply with all federal, state, and local laws regarding the transfer of students; and

WHEREAS, Texas Education Code 11.151 gives the Board the exclusive power and duty to govern and oversee the management of the public schools of the District, including but not limited to, delegating certain authority to the Superintendent; and

WHEREAS, the Board has delegated the authority to approve regular transfer requests to the Superintendent or another designated official of the school district designated by the Superintendent; and

WHEREAS, House Bill (HB) 1959 of the Texas Legislature provides that on the request of a peace officer who is a parent of or person standing in parental relation to a student, the Board of Trustees of a school district or the Board’s designee shall transfer the student to another district campus or to another school district under an agreement under Texas Education Code Section 25.035; and

WHEREAS, the Board recognizes the importance of supporting the needs of peace officers and their families.

**NOW, THEREFORE, BE IT RESOLVED**, that:

1. The Board of Trustees or its designee shall approve the request for Mikiyah McLaren, a student from Ferris ISD, as provided by HB 1959 – having received a request from a peace officer who is a parent of or person standing in parental relation to a student and a Resolution related to this matter from the Ferris ISD Board of Trustees.
2. This matter shall be conducted in accordance with the provisions of Texas Education Code Section 25.035.
3. The Board of Trustees hereby delegates the authority to approve this transfer request to the Superintendent or another designated official of the school district designated by the Superintendent.
4. This resolution shall take effect immediately upon its adoption.

Passed, Approved and Adopted this \_\_\_\_ day of September, 2025.

RED OAK INDEPENDENT SCHOOL DISTRICT

---

Melanie Petersen, President  
Red Oak ISD Board of Trustees

---

Sean Kelly, Secretary  
Red Oak ISD Board of Trustees

Equipment Purchase – Replacing Refrigerators, Heated Cabinets- ROMS, RPS, ROE

**Presented for:**

Board Action     X    

Report/Review Only \_\_\_\_\_

**Supporting documents:**

None \_\_\_\_\_

Attached     X    

Provided Later \_\_\_\_\_

**Contact Person:**

Victoria Ybarra, Director of Student Nutrition

Julie Phillips, Director of Purchasing

**Background Information:**

This purchase is for 2 Pass-through Heated Cabinets and 1 Reach-in Refrigerator at Red Oak Middle School, 1 Pass-through Refrigerator at Red Oak Elementary, and 1 Reach-in Refrigerator at Russell P. Schupmann Elementary to replace old and non-working units.

The capital expenditure request has been approved by TDA.

Quotes were obtained from:

Pasco Food Service Equip & Supplies

A-Tex Restaurant Supply

Ace Mart Restaurant Supply

Cook’s Direct

Jean’s Restaurant Supply

Supreme Fixture Company

Kirby Restaurant Supply

Trex Restaurant Equipment

The recommended vendor with the lowest price is Cook’s Direct.

**Fiscal Implications:**

Purchase will be made from the 2025-2026 Student Nutrition budget.

**Administrative Recommendation:**

Administration recommends approval of the purchase of the equipment listed above from Cook’s Direct in the amount of \$71,145.76 using Buyboard contract 683-22.

**Project:**  
 BUYBOARD - Traulsen  
 Red Oak ISD  
 Julie Phillips  
 Director of Purchasing  
 julie.phillips@redoakisd.org  
 972-617-2941

**From:**  
 Mike Ingargiola  
 Strategic Account Manager  
 (630) 566-9924  
 mingargiola@cooksdirect.com  
 ---  
 Cook's Direct  
 2250 75th St, Suite 200  
 Woodridge, IL 60517

Project Code: 36791



**Customer must specify which contract to buy with so Cook's Direct can properly and efficiently order requested products.**

**Sourcewell Account #58499/ 063022-COK**

-OR-

**Texas BuyBoard #683-22**

Item	Qty	Description	Sell	Sell Total
1	2 ea	<b>PASS-THRU HEATED CABINET</b> Traulsen Model No. RHF132WP-HHS Spec-Line Heated Cabinet, Pass-thru, one-section, stainless steel exterior and interior, standard depth cabinet, half-height doors, with EZ-Clean Gaskets, (3) clear coated adjustable shelves per section, microprocessor controls, 6' adjustable stainless steel legs, cETLus, ETL-Sanitation, ENERGY STAR®	\$13,448.04	\$26,896.08
	2 ea	6-year parts & labor, standard. Visit <a href="http://www.traulsen.com">www.traulsen.com</a> for details		
	2 ea	208-230/115v/60/1-ph, cord with NEMA L14-20P		
	2 ea	Thermometer side door: hinging to be determined		
	2 ea	Rear door hinging to be determined		
	4 ea	(1) pair EZ-Clean tray racks, 6 levels per half section, spacing 4-1/8", holds (1) 18" x 26", (2) 14" x 18", or (2) 12" x 20" pans	\$595.00	\$2,380.00
	6 ea	Credit for standard coated shelf, deduct	\$-92.16	\$-552.96
		<b>DELIVERY TO:</b> <b>RED OAK MIDDLE SCHOOL 154 LOUISE RITTER BLVD, RED OAK, TX 75154</b> ----		
			<b>ITEM TOTAL:</b>	<b>\$28,723.12</b>

Item	Qty	Description	Sell	Sell Total	
	2	<b>REACH-IN REFRIGERATOR</b> Traulsen Model No. RHT132WUT-FHS Spec-Line Refrigerator, Reach-in, one-section, 24.2 cu. ft., self-contained refrigeration, StayClear™ Condenser, variable speed compressor, stainless steel exterior & interior, standard depth, wide full-height door or doors with EZ-Clean Gaskets, (3) adjustable wire shelves per section, microprocessor controls, 6" adjustable stainless steel legs, R-290 Hydrocarbon refrigerant, 1/2 HP, 115v/60/1-ph, 7.6 amps, cETLus, ETL-Sanitation, ENERGY STAR®	\$12,968.54	\$12,968.54	
	1 ea	6-year parts & labor and 7 year compressor, standard. Visit <a href="http://www.traulsen.com">www.traulsen.com</a> for details			
	1 ea	115v/60/1-ph, cord with NEMA 5-15P, standard			
	1 ea	Full height solid door, standard			
	1 ea	Door hinging to be determined			
		<b>DELIVERY TO:</b> <b>RED OAK MIDDLE SCHOOL (WEST CAMPUS) 154 LOUISE RITTER BLVD, RED OAK, TX 75154</b> ----			
			<b>ITEM TOTAL:</b>	<b>\$12,968.54</b>	
	<hr/>				
		3	<b>PASS-THRU REFRIGERATOR</b> Traulsen Model No. RHT132WPUT-HHS Spec-Line Refrigerator, Pass-thru, one-section, self-contained refrigeration, StayClear™ Condenser, variable speed compressor, stainless steel exterior & interior, standard depth, wide half-height solid doors, both sides with EZ-Clean Gaskets, (3) adjustable wire shelves per section, microprocessor controls, 6" adjustable stainless steel legs, R-290 Hydrocarbon refrigerant, 1/2 HP, 115v/60/1-ph, 7.6 amps, cETLus, ETL-Sanitation, ENERGY STAR®	\$15,572.04	\$15,572.04
		1 ea	6-year parts & labor and 7 year compressor, standard. Visit <a href="http://www.traulsen.com">www.traulsen.com</a> for details		
1 ea		115v/60/1-ph, cord with NEMA 5-15P, standard			
1 ea		Half height solid door, standard			
1 ea		Half height solid door, standard			
1 ea		Thermometer side door: hinging to be determined			
1 ea		Rear door hinging to be determined			
2 ea		(1) pair EZ-Clean tray racks, 6 levels per half section, spacing 4-1/8", holds (1) 18" x 26", (2) 14" x 18", or (2) 12" x 20" pans	\$595.00	\$1,190.00	
3 ea		Credit for standard coated shelf, deduct	\$-92.16	\$-276.48	
		<b>DELIVERY TO:</b> <b>RED OAK ELEMENTARY-200 VELLE Y RIDGE DR, RED OAK, TX 75154</b> ----			
		<b>ITEM TOTAL:</b>	<b>\$16,485.56</b>		

Item	Qty	Description	Sell	Sell Total
4	1 ea	<b>REACH-IN REFRIGERATOR</b> Traulsen Model No. RHT132WUT-FHS Spec-Line Refrigerator, Reach-in, one-section, 24.2 cu. ft., self-contained refrigeration, StayClear™ Condenser, variable speed compressor, stainless steel exterior & interior, standard depth, wide full-height door or doors with EZ-Clean Gaskets, (3) adjustable wire shelves per section, microprocessor controls, 6" adjustable stainless steel legs,R-290 Hydrocarbon refrigerant, 1/2 HP, 115v/60/1-ph, 7.6 amps, cETLus, ETL-Sanitation, ENERGY STAR®	\$12,968.54	\$12,968.54
	1 ea	6-year parts & labor and 7 year compressor, standard. Visit www.traulsen.com for details		
	1 ea	115v/60/1-ph, cord with NEMA 5-15P, standard		
	1 ea	Full height solid door, standard		
	1 ea	Door hinging to be determined		
		<b>DELIVERY TO:</b> <b>RUSSELL P SCHUPMANN ELEMENTARY-401 E. OVILLA RD, GLENN HEIGHTS, TX 75154</b> ----		
			<b>ITEM TOTAL:</b>	<b>\$12,968.54</b>

4		<b>FREIGHT</b> FREE LTL FREIGHT; DOCK-TO-DOCK; FULLY CRATED ---- <b>QUOTE DOES NOT INCLUDE INSIDE DELIVERY, CONFIGURATION, INSTALLATION OR ANY FINAL CONNECTIONS</b> ----		
			Merchandise	\$71,145.76
			Total	\$71,145.76

Prices Good Until: 09/12/2025

**Customer must specify which contract to buy with so Cook's Direct can properly and efficiently order requested products.**

**Sourcewell Account #58499/ 063022-COK**

-OR-

**Texas BuyBoard #683-22**

Quote Approval

By affixing their signature to this document, the undersigned hereby affirms the accuracy of the provided information. The signee acknowledges that all utilities and dimensions specified are compatible with the operational requirements at the designated facility. Furthermore, it is confirmed that the listed equipment is suitable for passage through doorways, hallways, and vestibules from the receiving area to the kitchen.

In the event of equipment returns attributable to inaccuracies in utilities or measurements, the signee acknowledges the imposition of a manufacturer restocking fee, in addition to the applicable return shipping charges.

**Receiving Policy and Guidelines:**

Prior to signing for the delivery, it is crucial to thoroughly inspect and count all cartons. Note any shortages, damages, or problems on the delivery receipt. In case of visible damage, refuse damaged boxes by checking for crushed corners, wetness, or punctures. If the delivery includes equipment, inspect all parts before signing.

If a full inspection is not possible, please make a note on the bill of lading that you will inspect at a later time (within 24 hours of receipt).

For refused shipments, the customer is responsible for full freight charges and applicable fees in both directions, unless the refusal is due to shipment damage or a shipping error made by CooksDirect.com.

Most items are eligible for return within a 30-day period from the customer's receipt of the shipment. Depending on the manufacturer, a restocking fee of 15% to 50% may be applicable. Return freight charges may also apply based on the manufacturer's policy. For inquiries regarding specific return policies for a particular manufacturer or product, kindly reach out to our Customer Service team at 1-866-506-3048 or via email at [customerservice@cooksdirect.com](mailto:customerservice@cooksdirect.com).

Please review the following criteria for returning an order:

1. Returned items must be unused, undamaged, and returned intact with original materials.
2. Special ordered or custom items cannot be returned.

Returns must be initiated within the first 30 days of receipt. Orders exceeding the 30-day return window are not eligible for returns through Cook's Direct. For product issues, please contact the manufacturer, as most large equipment is covered by a 1-year warranty.

**Shipping & Delivery Information:**

To ensure your order is processed in a timely manner please provide the following information along with your signature:

**Delivery Address**

**Contact Name:**

**Phone Number:**

**Receiving Hours:**

**Receiving Dock Onsite (Y/N):**

(If there is no dock onsite, additional fees for lift gate service may apply)

Note: large/oversized items may deliver on a full sized semi truck. If your receiving area cannot accommodate a full sized truck please notify your sales or sales support representative.

**Forklift/Pallet Jack Onsite (Y/N):**

Acceptance: \_\_\_\_\_ Date: \_\_\_\_\_

Printed Name: \_\_\_\_\_

Project Grand Total: \$71,145.76



Project \_\_\_\_\_  
 AIA # \_\_\_\_\_ SIS # \_\_\_\_\_  
 Item # \_\_\_\_\_ Quantity \_\_\_\_\_ C.S.I. Section 114000

## R Series

Pass-Thru Heated Cabinet Model  
 32" Deep, W-Width



### STANDARD PRODUCT FEATURES

- Stainless Steel Exterior & Interior
- Traulsen's Smart Control™ with LED Display
- Ducted Fan Air Distribution System
- Standard Operating Temperature Range 140-180°F
- ON/OFF Switch Located on Control Face
- Full or Half-Height Stainless Steel Doors with Lock(s)
- Self-Closing Doors with Stay Open Feature
- Standard Door Hinging F & R: 132WP = Right (other hings available)
- Automatically Activated LED Lights
- Stainless Steel Breaker Caps
- Three Adjustable Wire Shelves Per Section, Supported on Pilasters (factory installed)
- Magnetic Snap-In EZ-Clean™ Door Gasket(s)
- Gasket-Protecting Door Liner(s)
- Stainless Steel One-Piece Louver Assembly - Front & Rear
- 9' Cord & Plug Attached
- Set of (4) 6" High Adjustable Stainless Steel Legs

### ACCESSORIES & OPTIONS

- SmartConnect™ Monitoring App with Wi-Fi Connectivity
- Re-Hinging Feature for Door(s)
- Accommodates EZ-Clean™ Tray Racks
- #1 Type Trayslides to Accommodate (1) 18" x 26" or (2) 14" x 18" Pans
- #4 Type Trayslides to Accommodate 18 to 19 Levels for 18" x 26" Pans
- Universal Type Trayslides to Accommodate Either (1) 18" x 26", (2) 14" x 18", or (2) 12" x 20" Pans
- Additional Coated Wire or Optional Stainless Steel Shelves
- EZ-Open™ Foot Pedal (full height doors only)
- Locking Hasps (padlocks supplied by others)
- Optional 115/60/1, 208-230/60/1, or Export 220/50/1 Voltage
- Kool Klad™ Exterior Laminate Decor
- Set of (4) 4 1/8" or 6" High Casters in Lieu of Legs
- Other Support Options: 4 1/2" High Base or 6" High Kickplate (for use with standard legs)
- Clear Glass Door(s) in Place of One or More Solid Door(s)
- Heat Shield
- Prison/Correctional Facility Options



Intertek



Intertek



Models listed to the applicable UL, CSA and NSF standards by an approved NRTL. Consult the factory or unit data plate for additional information.

### AVAILABLE CONFIGURATIONS

#### R Series Models

RHF132WP-FHS  
 RHF132WP-HHS

#### Door(s)

Full Height Solid  
 Half Height Solid

- GUARANTEED FOR LIFE CAM-LIFT HINGES
- GUARANTEED FOR LIFE HORIZONTAL WORKFLOW DOOR HANDLES



ENERGY STAR® Listed Commercial Hot Food Holding Cabinet  
 For full listing visit [energystar.gov](http://energystar.gov)



# R Series

Pass-Thru Heated Cabinet Model  
32" Deep, W-Width

## MODELS:

RHF132WP-HHS, RHF132WP-FHS

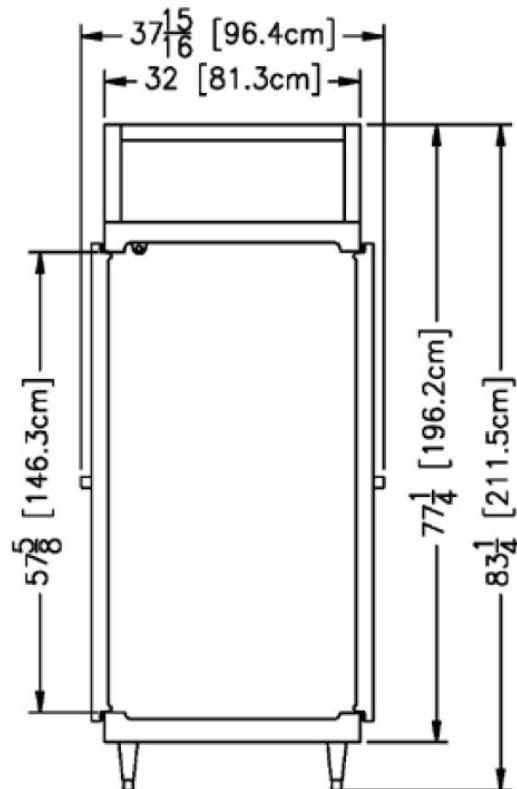
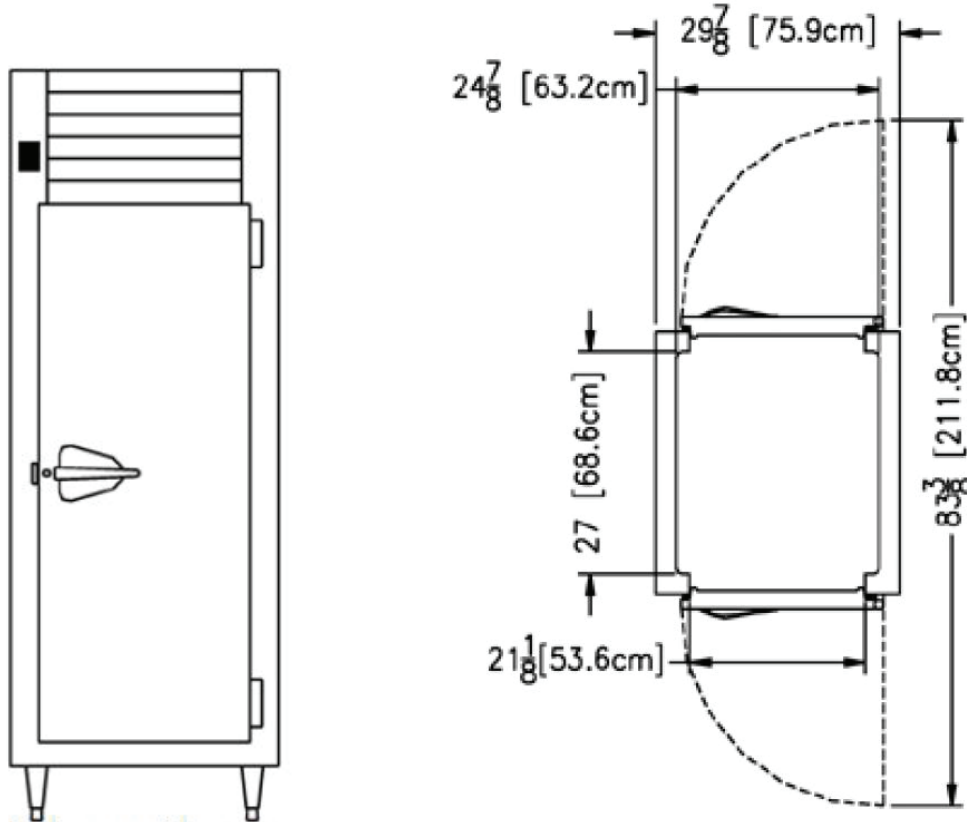

CAD and/or Revit Files Available

<https://traulsen.klccad.com/>



## R Series

Pass-Thru Heated Cabinet Model  
32" Deep, W-Width

### MODELS:

RHF132WP-HHS, RHF132WP-FHS

MODELS	RHF132WP
<b>DIMENSIONAL DATA</b>	
Net capacity cu. ft.	24.86 (704 cu l)
Length - overall in.	29 <sup>7</sup> / <sub>8</sub> " (75.9 cm)
Depth - overall in.	37 <sup>15</sup> / <sub>16</sub> " (96.4 cm)
Depth - over body in.	32" (81.3 cm)
Depth - door open 90° in.	83 <sup>3</sup> / <sub>8</sub> " (211.8 cm)
Clear door width in. <sup>1</sup>	21 <sup>1</sup> / <sub>8</sub> " (53.6 cm)
Clear half-door height in.	27 <sup>1</sup> / <sub>2</sub> " (69.9 cm)
Clear full-door height in.	57 <sup>5</sup> / <sub>8</sub> " (146.3 cm)
Height - overall on 6" legs	83 <sup>1</sup> / <sub>4</sub> " (211.5 cm)
No. Standard Shelves	3
Shelf area sq. ft. <sup>2</sup>	13.46 (1.25 sq. m)
<b>ELECTRICAL DATA</b>	
Voltage <sup>3</sup>   Plug	208-230/115/60/1   NEMA L14-20P or NEMA 5-20P
Heater Wattage   Full Load Amperes	@208V = 1500   7.7 @230V = 1836   8.5 @240V = 2000   8.8 @115V = 1500   14.2
<b>SHIPPING DATA</b>	
Length - Crated in.	48" (121.9 cm)
Depth - Crated in.	42" (106.7 cm)
Height - Crated in.	85" (215.9 cm)
Volume - Crated cu. ft.	99.17 (2808.2 cu l)
Weight - Crated lbs.	429 (194.6 kg)

**NOTES:** Figures in parentheses reflect metric equivalents.

- Please note that the available cabinet width narrows for 5<sup>3</sup>/<sub>8</sub>" from the top of the door frame to 20<sup>1</sup>/<sub>8</sub>" in order to allow for the heater fans.
- Area of standard shelf compliment only, does not include storage area of additional shelves or available on cabinet bottom.
- Heater is capable of operation from 208V to 230V as supplied standard. Actual amp figure will change at any voltage other than 208V.

When ordering please specify: Voltage, Hinging, and Options

Equipped with one NEMA L14-20P Plug  
(1 section models @ 208-230V/115/60/1)



Equipped with one NEMA 5-20P Plug  
(1 section models @115V only)



### EQUIPMENT SPECIFICATIONS

#### CONSTRUCTION, HARDWARE, INSULATION

The interior is made from stainless steel and the cabinet exterior front, one piece sides, louver assembly, door and door liner is constructed of heavy gauge stainless steel. A set of four (4) adjustable 6" high stainless steel legs are included.

Door(s) are equipped with a gasket protecting metal door pan, removable plug cylinder locks & guaranteed for life gravity action, self-closing metal, cam-lift hinges with a stay open feature. Hinges include a concealed switch to automatically activate the interior LED lighting. Guaranteed for life, workflow door handles are mounted horizontally over recess in door which limits protrusion from door face into aiseways. Doors have seamless, polished metal corners.

Gasket profile & material simplify cleaning & increase overall gasket life. Both the cabinet & door(s) are insulated with an average of 2" thick high density, non-CFC, foamed in place polyurethane.

#### HEATING SYSTEM

A low watt density, serpentine style, heater is employed for the generation of electric heat. Low velocity air is forced across its large surface area to efficiently move heat radiating away from these through a down-air distribution duct, where it is then evenly distributed throughout the cabinet, assuring the proper holding environment for hot food product, without drying. A vent, located at the top of the cabinet, is included for positive humidity control.

#### CONTROL

Traulsen's Smart Control™ features advanced control algorithms & sophisticated diagnostic capabilities to optimize performance. Utilizing smart sensors, it adapts the operation of the heating system to a variety of environments & usage patterns. The Smart Control™ also offers a complete set of visual alarms designed to alert the user to critical events such as power outages or a prolonged door opening. In the event of an alarm, a dedicated Alarm LED will illuminate, informing the user of the critical event and duration.

#### INTERIOR

Standard interior arrangements include three (3) coated wire factory installed shelves per section, mounted on pilasters. Shelves are full-width & do not have any large gaps between them requiring the use of "bridge" or "junior" shelves. Recommended load limit per shelf should not exceed 225 lbs. Factory installed optional trayslides may be purchased in combination with, or in lieu of these.

#### WARRANTY

A six year parts and labor warranty is provided standard.



Project \_\_\_\_\_  
 AIA # \_\_\_\_\_ SIS # \_\_\_\_\_  
 Item # \_\_\_\_\_ Quantity \_\_\_\_\_ C.S.I. Section 114000



BLAST CHILLER ACCESSORIES

## TBC-SERIES

### Optional Condensate Evaporators for Models TBC13, TBC1H/TBC1HR & TBC2H/TBC2HR

#### Description of Purpose

Designed for use with the above models in order to provide condensate removal in lieu of a floor drain. Each includes a two-piece stainless steel upper and lower housing, which provides protection from damaging impacts, and a thermally activated evaporative pan with 9 foot cord and plug (requires provision of a separate electrical outlet) for models TBC1H, TBC1HR, TBC2H & TBC2HR. Note: On model TBC13 this can be mounted to the cabinet bottom, however for models TBC1H, TBC1HR, TBC2H & TBC2HR these are installed inside of a compartment at the cabinet bottom.

ACCESSORY	TBCACC-60018 (for all roll-in/roll-thru models only)
<b>Floor Mounted Condensate Evaporator</b>	
L x D x H - Overall in.	13 1/8 (33.3 cm) x 5 1/8 (12.9 cm) x 3 1/2 (8.9 cm)
NEMA Plug (3 wire with ground)	5-15 P (9' cord)
Voltage	115/60/1
Full Load Amps	1.5

**NOTE: Plug requires separate electrical outlet.**

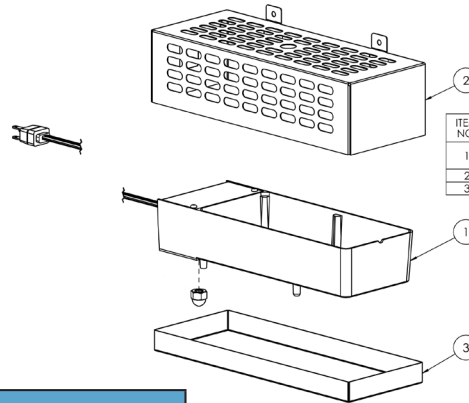

ITEM NO.	PART NUMBER	DESCRIPTION	Default/QTY.
1	329-60072-01	117V EL. CONDENSATE EVAPORATOR W/ 120' CORD	1
2	701-60143-00	CONDENSATE EVAP. EXT. COVER	1
3	701-60144-00	COND. EVAPORATOR BTM COVER	1

ACCESSORY	TBCACC-BMCE (for TBC13 model only)
<b>Bottom Mounted Condensate Evaporator</b>	
L x D x H - Overall in.	12 1/2 (31.73 cm) x 4 7/8 (12.4 cm) x 4 1/8 (10.5 cm)
Plug (3 wire with ground)	Plugs into Receptacle on Rear of Unit (18" cord)
Voltage	220/60/1
Full Load Amps	1.4

**NOTE: On model TBC13 the cabinet includes provisions for mounting the condensate evaporator to the cabinet bottom. This includes an outlet located on the cabinet bottom and pre-drilled mounting holes on the cabinet bottom.**

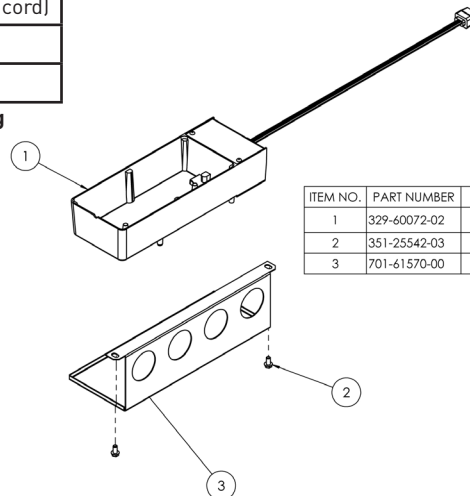

ITEM NO.	PART NUMBER	DESCRIPTION	QTY.
1	329-60072-02	220V EL. CONDENSATE EVAPORATOR W/18' CORD	1
2	351-25542-03	1/4-20 X 1/2 HWH MACHINE SCREW	2
3	701-61570-00	BMCE BRACKET TBC13	1

Approved by \_\_\_\_\_ Date \_\_\_\_\_ Approved by \_\_\_\_\_ Date \_\_\_\_\_



## TBC-SERIES

Blast Chiller, Optional Roll-In Rack  
for Models TBC1H/TBC1HR & TBC2H/TBC2HR

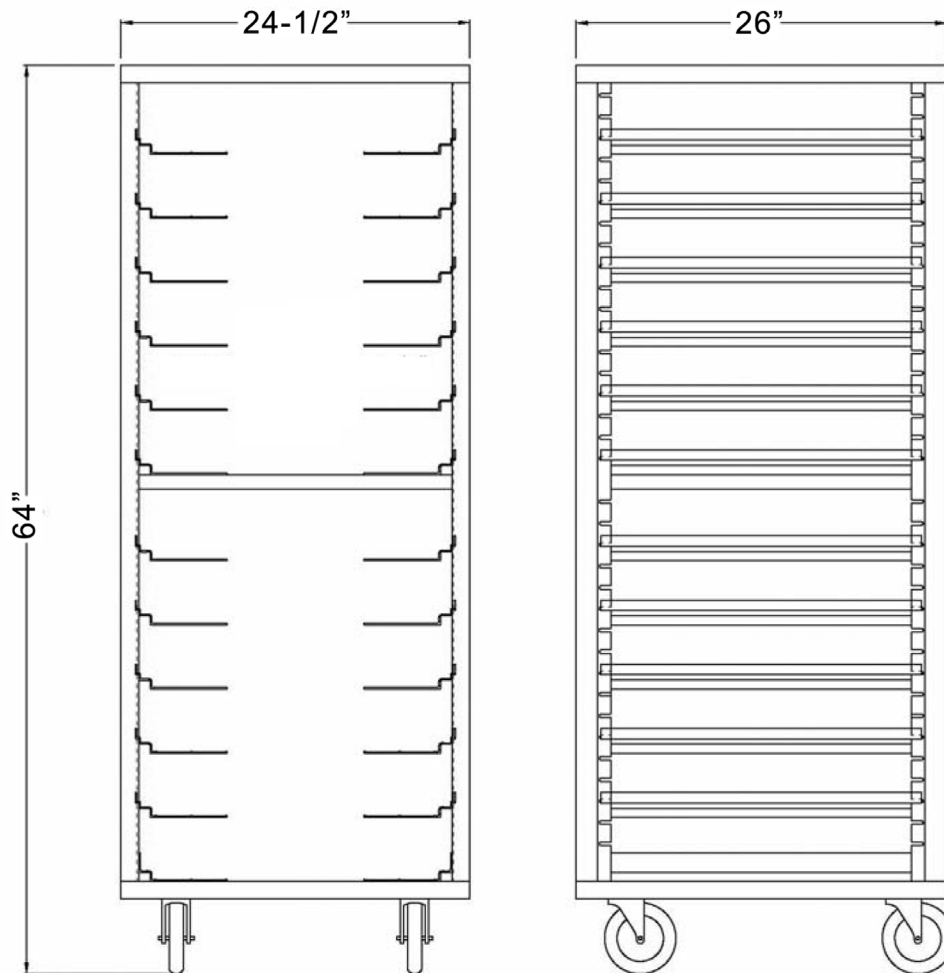

ACCESSORY	TBCACC-OTRTR (for all roll-in/roll-thru models only)
<b>OPTIONAL ROLL-IN RACK - PART# 342-60132-00</b>	
Length in.	24-1/2" (62.0 cm)
Depth in.	26" (66.0 cm)
Height in.	64" (162.5 cm)
Capacity 12"x20"x2-1/2"	24 Pans
Capacity 18"x26"	12 Sheet Pans
Capacity 14"x18"	24 Sheet Pans

#### CONSTRUCTION & HARDWARE:

Welded construction with casters. Provided with adjustable Universal Tray Slides. Roll-In Rack provides maximum chill performance, with open sides for optimum airflow.



## G-SERIES ACCESSORY KITS

### 1 Section Models

#### G-Series Accessory Kit Location Guide:

Each kit includes all necessary mounting hardware except where noted. All G-Series accessory kits are pre-packaged for easy installation at the job site.

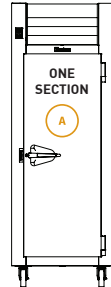

One Section Models

A

#### TRAYSLIDES

- G1ACC-TK1
- G1ACC-TK2
- G1ACC-TK4
- G13ACC-1EZ
- G13ACC-UEZ
- G13ACC-HDUEZ

#### SHELVES

- G1ACC-SHLF1
- G1ACC-SHLF2
- G1ACC-SHLF5
- G1ACC-BTL5
- G12ACC-BTL1

DESCRIPTION	MODEL	HEATED CABINET	REFRIG. / FREEZER
<b>EZ-CHANGE KITS</b>			
(4) pairs #1 trayslides with pilasters per 1/2 section (top or bottom)	<b>G13ACC-1EZ</b>	Available	Available
(3) pairs universal with pilasters per 1/2 section (top or bottom)	<b>G13ACC-UEZ</b>	Available	Available
(3) pairs heavy duty universal with pilasters per 1/2 section (top or bottom)	<b>G13ACC-HDUEZ</b>	Available	Available
<b>TRAYSLIDES</b>			
(8) pairs #1 trayslides includes pilasters per full section	<b>G1ACC-TK1</b>	Available	Available
(2) pairs #4 trayslides includes pilasters per full section	<b>G1ACC-TK2</b>	Available	Available
(7) pairs universal trayslides includes pilasters per full section	<b>G1ACC-TK4</b>	Available	Available
<b>SHELVES</b>			
(3) epoxy coated shelves on pins	<b>G1ACC-SHLF1</b>	Not Available	Available
(3) epoxy coated shelves on pilasters	<b>G1ACC-SHLF2</b>	Not Available	Available
(1) epoxy coated shelf with pins & clips	<b>G1ACC-SHLF5</b>	Not Available	Available
(5) bottle shelves with mounting hardware (glass door models only)	<b>G1ACC-BTL5</b>	Not Available	Available
(1) bottle shelf with clips without mounting hardware (glass door models only)	<b>G12ACC-BTL1</b>	Not Available	Available

### OPTIONS

DESCRIPTION	PRICE
Export Crating	Available

### OTHER ACCESSORY KITS – FOR ALL G-SERIES REFRIGERATOR, FREEZER & HEATED MODELS

DESCRIPTION	MODEL	PRICE
Set of (4) 6" high legs	<b>GSACC-LEGS</b>	Available
Set of (4) 6" high casters	<b>CK1</b>	Available
Set of (4) 4-5/8" high casters	<b>CK3</b>	Available
Set of (4) 2-3/4" high casters	<b>CK14</b>	Available
Set of (4) 6" stainless steel flanged legs	<b>LK3</b>	Available
(1) pair #1 type trayslides (Must order pilasters. Consult factory for other trayslide and pilaster kit options.)	<b>GSACC-#1TS</b>	Available
(1) pair #4 type trayslides (Must order pilasters. Consult factory for other trayslide and pilaster kit options.)	<b>GSACC-#4TS</b>	Available
(1) pair universal type trayslides (Must order pilasters. Consult factory for other trayslide and pilaster kit options.) (excludes 2 section heated cabinets only)	<b>GSACC-UVTS</b>	Available
(1) pair EZ-Change #1 type trayslides (Must order pilasters. Consult factory for other trayslide and pilaster kit options.)	<b>GSACC-1EZ</b>	Available
(1) pair EZ-Change universal type trayslides (Must order pilasters. Consult factory for other tray slide and pilaster kit options.)	<b>GSACC-UEZ</b>	Available
(1) pair EZ-Change heavy duty universal type trayslides (Must order pilasters. Consult factory for other trayslide and pilaster kit options.)	<b>GSACC-HDUEZ</b>	Available
(1) set pilasters and clips for shelves (Not applicable for trayslides)	<b>GSACC-PLSTS</b>	Available



## G-SERIES ACCESSORY KITS

### 2 Section Models

#### G-Series Accessory Kit Location Guide:

Each kit includes all necessary mounting hardware except where noted. All G-Series accessory kits are pre-packaged for easy installation at the job site.

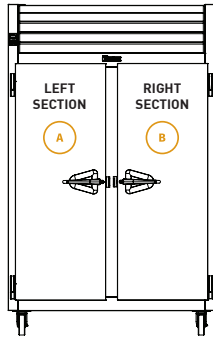

Two Section Models

#### TRAYSLIDES

- G23ACC-TK1LR
- G23ACC-TK2LR
- G23ACC-TK4LR
- G23ACC-1EZ
- G23ACC-UEZ
- G23ACC-HDUEZ

#### SHELVES

- G23ACC-SHLF1
- G23ACC-SHLF2
- G23ACC-SHLF9
- G2ACC-BTL5

#### TRAYSLIDES

- G23ACC-TK1LR
- G23ACC-TK2LR
- G23ACC-TK4LR
- G23ACC-1EZ
- G23ACC-UEZ
- G23ACC-HDUEZ

#### SHELVES

- G23ACC-SHLF5
- G23ACC-SHLF6
- G23ACC-SHLF11
- G2ACC-BTL5

DESCRIPTION	MODEL	HEATED CABINET	REFRIG. / FREEZER
<b>EZ-CHANGE KITS</b>			
<b>LEFT AND RIGHT SECTION:</b>			
(4) pairs #1 trayslides with pilasters per ½ section (top and bottom)	<b>G23ACC-1EZ</b>	Not Available	Available
(3) pairs universal with pilasters per ½ section (top and bottom)	<b>G23ACC-UEZ</b>	Not Available	Available
(3) pairs heavy duty universal with pilasters per ½ section (top and bottom)	<b>G23ACC-HDUEZ</b>	Not Available	Available
<b>TRAY SLIDES</b>			
<b>LEFT AND RIGHT SECTION:</b>			
(8) pairs #1 trayslides (with pilasters) per full section	<b>G23ACC-TK1LR</b>	Not Available	Available
(2) pairs #4 trayslides (with pilasters) per full section	<b>G23ACC-TK2LR</b>	Not Available	Available
(7) pairs universal trayslides (with pilasters) per full section	<b>G23ACC-TK4LR</b>	Available	Available
<b>SHELVES</b>			
<b>LEFT SECTION:</b>			
(3) epoxy coated shelves on pins	<b>G23ACC-SHLF1</b>	Not Available	Available
(3) epoxy coated shelves on pilasters	<b>G23ACC-SHLF2</b>	Not Available	Available
(1) epoxy coated shelf with pins & clips	<b>G23ACC-SHLF9</b>	Not Available	Available
<b>RIGHT SECTION:</b>			
(3) epoxy coated shelves on pins	<b>G23ACC-SHLF5</b>	Not Available	Available
(3) epoxy coated shelves on pilasters	<b>G23ACC-SHLF6</b>	Not Available	Available
(1) epoxy coated shelf with pins & clips	<b>G23ACC-SHLF11</b>	Not Available	Available
<b>LEFT OR RIGHT SECTION:</b>			
(1) plated shelf with pins & clips (hot food cabinets only)	<b>G23ACC-SHLF13</b>	Available	Not Available
(5) bottle shelves with mounting hardware (Glass door models only. Fits 1 section of a 2 section unit. Requires 2 kits to outfit both sections.)	<b>G2ACC-BTL5</b>	Not Available	Available

### OPTIONS

DESCRIPTION	PRICE
Export Crating	Available



## G-SERIES ACCESSORY KITS

### 3 Section Models

#### G-Series Accessory Kit Location Guide:

Each kit includes all necessary mounting hardware except where noted. All G-Series accessory kits are pre-packaged for easy installation at the job site.

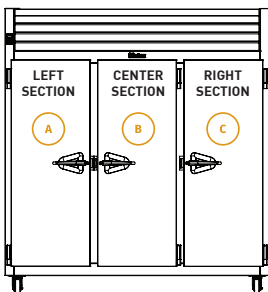

Three Section Models

A		B		C	
TRAYSLIDES	SHELVES	TRAYSLIDES	SHELVES	TRAYSLIDES	SHELVES
■ G23ACC-TK1LR	■ G23ACC-SHLF1	■ G3ACC-TK1C	■ G3ACC-SHLF5	■ G23ACC-TK1LR	■ G23ACC-SHLF5
■ G23ACC-TK2LR	■ G23ACC-SHLF2	■ G3ACC-TK2C	■ G3ACC-SHLF6	■ G23ACC-TK2LR	■ G23ACC-SHLF6
■ G23ACC-TK4LR	■ G23ACC-SHLF9	■ G3ACC-TK4C	■ G3ACC-SHLF15	■ G23ACC-TK4LR	■ G23ACC-SHLF11
■ G23ACC-1EZ	■ G3ACC-BTL5-LR	■ G13ACC-1EZ	■ G3ACC-BTL5-C	■ G23ACC-1EZ	■ G3ACC-BTL5-LR
■ G23ACC-UEZ		■ G13ACC-UEZ		■ G23ACC-UEZ	
■ G23ACC-HDUEZ		■ G13ACC-HDUEZ		■ G23ACC-HDUEZ	

DESCRIPTIONS	MODEL	REFRIG. / FREEZER
<b>EZ-CHANGE KITS: (DOES NOT APPLY TO G-SERIES HEATED CABINETS)</b>		
<b>LEFT AND RIGHT SECTIONS:</b>		
(4) pairs #1 trayslides with pilasters per 1/2 section (top and bottom)	<b>G23ACC-1EZ</b>	Available
(3) pairs universal with pilasters per 1/2 section (top and bottom)	<b>G23ACC-UEZ</b>	Available
(3) pairs heavy duty universal with pilasters per 1/2 section (top and bottom)	<b>G23ACC-HDUEZ</b>	Available
<b>CENTER SECTION:</b>		
(4) pairs #1 trayslides with pilasters per 1/2 section (top and bottom)	<b>G13ACC-1EZ</b>	Available
(3) pairs universal with pilasters per 1/2 section (top and bottom)	<b>G13ACC-UEZ</b>	Available
(3) pairs heavy duty universal with pilasters per 1/2 section (top and bottom)	<b>G13ACC-HDUEZ</b>	Available
<b>TRAYSLIDES: (DOES NOT APPLY TO G-SERIES HEATED CABINETS)</b>		
<b>LEFT AND RIGHT SECTIONS:</b>		
(8) pairs #1 trayslides (with pilasters) per full section	<b>G23ACC-TK1LR</b>	Available
(2) pairs #4 trayslides (with pilasters) per full section	<b>G23ACC-TK2LR</b>	Available
(7) pairs universal trayslides (with pilasters) per full section	<b>G23ACC-TK4LR</b>	Available
<b>CENTER SECTION:</b>		
(8) pairs #1 trayslides (with pilasters) per full section	<b>G3ACC-TK1C</b>	Available
(2) pairs #4 trayslides (with pilasters) per full section	<b>G3ACC-TK2C</b>	Available
(7) pairs universal trayslides (with pilasters) per full section	<b>G3ACC-TK4C</b>	Available
<b>SHELVES: (DOES NOT APPLY TO G-SERIES HEATED CABINETS)</b>		
<b>LEFT SECTION:</b>		
(3) epoxy coated shelves on pins	<b>G23ACC-SHLF1</b>	Available
(3) epoxy coated shelves on pilasters	<b>G23ACC-SHLF2</b>	Available
(1) epoxy coated shelf with pins & clips (for Left Section)	<b>G23ACC-SHLF9</b>	Available
<b>CENTER SECTION:</b>		
(3) epoxy coated shelves on pins	<b>G3ACC-SHLF5</b>	Available
(3) epoxy coated shelves on pilasters	<b>G3ACC-SHLF6</b>	Available
(1) epoxy coated shelf with pins & clips (for Center Section)	<b>G3ACC-SHLF15</b>	Available
(5) bottle shelves with mounting hardware (glass door models only)	<b>G3ACC-BTL5-C</b>	Available
<b>RIGHT SECTION:</b>		
(3) epoxy coated shelves on pins	<b>G23ACC-SHLF5</b>	Available
(3) epoxy coated shelves on pilasters	<b>G23ACC-SHLF6</b>	Available
(1) epoxy coated shelf with pins & clips (for Right Section)	<b>G23ACC-SHLF11</b>	Available
<b>LEFT OR RIGHT SECTION:</b>		
(5) bottle shelves with mounting hardware (Glass door models only. Fits Left or Right section of a 3 section unit. Requires 2 kits to outfit both Left and Right sections.)	<b>G3ACC-BTL5-LR</b>	Available

### OPTIONS

DESCRIPTIONS	PRICE
Export Crating	Available



# G-SERIES ACCESSORY KITS

## Trayslide & Shelf Versatility Chart

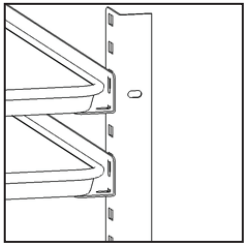
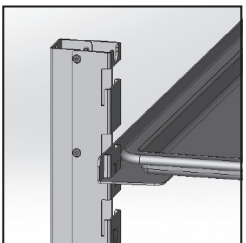
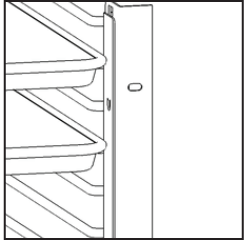
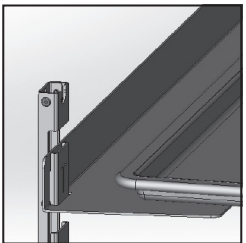
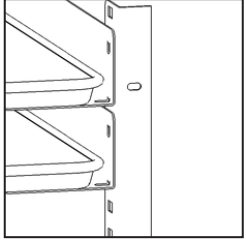
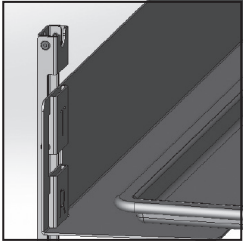
TRAYSLIDES	EZ-CHANGE TRAYSLIDES
 <p><b>#1 Trayslides Standard</b></p>	 <p><b>#1 Trayslides EZ-Change</b></p>
 <p><b>#4 Trayslides Standard</b></p>	 <p><b>Universal Trayslides EZ-Change</b></p>
 <p><b>Universal Trayslides Standard</b></p>	 <p><b>Heavy-Duty Universal Trayslides EZ-Change</b></p>

- NOTES:**
- For all after market parts call Traulsen parts department 800-825-8220.
  - The above quantities represent the maximum amount of tray slides recommended by Traulsen to achieve best air circulation and refrigeration performance.
  - Optional trayslides are not available for Compact Undercounter, and Prep Tables models
  - EZ-Change Interior Universal Trayslides max weight 75 lbs. EZ-Change Heavy Duty Universal Trayslides max weight 125 lbs.
  - #1, #4, universal and HD universal EZ change trayslides are not available for 2 section G Series heated cabinets.\*
  - All G-Series accessory kits are pre-packaged for easy installation at the job site.

### TRAYSLIDES

DESCRIPTION	SPACING			
<b>#1 TRAYSLIDES (NOT AVAILABLE FOR 2 SECTION G HEATED)*</b>				
<b>16 ga. stainless steel angle type for bottom support of:</b> (1) 18" x 26" Pan or (2) 14" x 18" Pans	<b>2"</b>	<b>3"</b>	<b>4"</b>	<b>5"</b>
Behind full height door – all models	28	19	14	11
Behind upper half height door – all models	13	9	7	5
Behind lower half height door – all models	13	9	7	5
<b>#1 Trayslides – EZ-Change Interior</b> (Not available for 2 section G Heated)*	<b>2"</b>	<b>4"</b>		
Behind full height door – all models	26	13		
Behind upper half height door	12	6		
Behind lower half height door	12	6		
<b>#4 TRAYSLIDES – STANDARD (NOT AVAILABLE FOR 2 SECTION G HEATED)*</b>				
<b>Plated steel rod type for rim support of:</b> (1) 18" x 26" Pan (One pair of #4 trayslides accommodates one half section)	<b>1-1/2"</b>			
Behind full height door – all models	38			
Behind upper half height door – all models	18			
Behind lower half height door – all models	18			
<b>UNIVERSAL TRAYSLIDES – STANDARD</b>				
<b>16 ga. stainless steel angle type for bottom support of:</b> (1) 18" x 26" Pan or (2) 14" x 18" Pans or (2) 12" x 20" Pans. For heated cabinets reduce available number of trayslides by 1 (full door and the upper section of a half-door)	<b>4"</b>	<b>5"</b>	<b>6"</b>	
Behind full height door – all models	14	11	9	
Behind upper half height door – all models	6	5	4	
Behind lower half height door – all models	7	5	4	
<b>Universal Trayslides – EZ-Change Interior</b> (Not available for 2 Section G Heated)*. For heated cabinets reduce available number of trayslides by 1 (full door and the upper section of a half-door)	<b>2-1/4"</b>		<b>4-1/2"</b>	
Behind full height door – all models	22		11	
Behind upper half height door	11		5	
Behind lower half height door	11		5	
<b>Heavy-Duty Universal Trayslides – EZ-Change Interior</b> (Not available for 2 Section G Heated)*. For heated cabinets reduce available number of tray slides by 1 (full door and the upper section of a half-door)	<b>4-1/2"</b>		<b>9"</b>	
Behind full height door – all models	10		5	
Behind upper half height door	5		2	
Behind lower half height door	5		2	

### SHELVES (SOME SHELVES ARE NOT AVAILABLE FOR G HEATED)

CAPACITY	STD.	MAX.
Behind full height door mounted on standard shelf pins	3	9
Behind half height door mounted on standard shelf pins	3	8
Behind full height door mounted on optional pilasters	3	13 (4" spacing)
Behind half height door mounted on optional pilasters	3	12 (4" spacing)



Project \_\_\_\_\_

AIA # \_\_\_\_\_ SIS # \_\_\_\_\_

Item # \_\_\_\_\_ Quantity \_\_\_\_\_ C.S.I. Section 114000

## R Series

30" Wide Reach-In Refrigerator  
32" Deep, Self-Contained



Intertek



Intertek



Models listed to the applicable UL, CSA and NSF standards by an approved NRTL. Consult the factory or unit data plate for additional information.

### AVAILABLE CONFIGURATIONS

#### R Series Models

RHT132WUT-FHS

RHT132WUT-HHS

#### Door(s)

Full Height Solid

Half Height Solid

### STANDARD PRODUCT FEATURES

- Stainless Steel Exterior & Interior
- Variable Speed Compressor Adapts to the Work Environment
- Traulsen's Smart Control™ with LED Display
- StayClear™ Condenser Coil
- Balanced, Self-Contained Refrigeration System Using R290
- Full or Half-Height Stainless Steel Door(s) with Lock(s)
- Anti-Condensate Door Perimeter Heater
- Self-Closing Door with Stay Open Feature
- Standard Door Hinging: 132W = Right (other hings available)
- Automatically Activated LED Lights
- Stainless Steel Breaker Caps
- Three Adjustable, Coated Wire Shelves Per Section, Supported on Shelf Pins (factory installed)
- Automatic Non-Electric Condensate Evaporator
- Magnetic Snap-In EZ-Clean™ Door Gasket
- Gasket-Protecting Raised Door Liner
- Thermostatic Expansion Valve Metering Device
- Stainless Steel One-Piece Louver Assembly
- 9' Cord & Plug Attached
- Set of (4) 6" High Adjustable Stainless Steel Legs

### ACCESSORIES & OPTIONS

- SmartConnect™ Monitoring App with Wi-Fi Connectivity
- Stainless Steel Finished Back with Rear Louvers
- Option to Relocate Electrical Box
- Accommodates EZ-Clean™ Tray Racks
- #1 Type Trayslides to Accommodate (1) 18" x 26" or (2) 14" x 18" Pans
- #4 Type Trayslides to Accommodate 18 to 19 Levels for 18" x 26" Pans
- Universal Type Trayslides to Accommodate (1) 18" x 26", (2) 14" x 18", or (2) 12" x 20" Pans
- Additional Coated Wire or Optional Stainless Steel Shelves
- Stainless Steel Banking Strip
- EZ-Open™ Foot Pedal (full-height doors only)
- Positive Action Latch (consult factory)
- Locking Hasps (padlock supplied by others)
- Optional 208-230/115/60/1, 208-230/60/1, or Export 220-240/50/1 Voltage
- Kool Klad™ Exterior Laminate Decor (consult factory)
- Set of (4) 4 1/8" or 6" High Casters in Lieu of Legs
- 6" Stainless Steel Flanged Legs
- Other Support Options: 4 1/2" High Base or 6" High Kickplate (for use with standard legs)
- Heat Shield

**\*Remote application without R-290 refrigerant is available, see form TR35837 for details.**



ENERGY STAR® Listed Commercial Refrigerator  
For full listing visit [energystar.gov](http://energystar.gov)

**- GUARANTEED FOR LIFE CAM-LIFT HINGES**  
**- GUARANTEED FOR LIFE HORIZONTAL WORKFLOW DOOR HANDLES**

Approved by \_\_\_\_\_ Date \_\_\_\_\_ Approved by \_\_\_\_\_ Date \_\_\_\_\_

44



# R Series

30" Wide Reach-In Refrigerator  
32" Deep, Self-Contained

## MODEL:

RHT132WUT-HHS

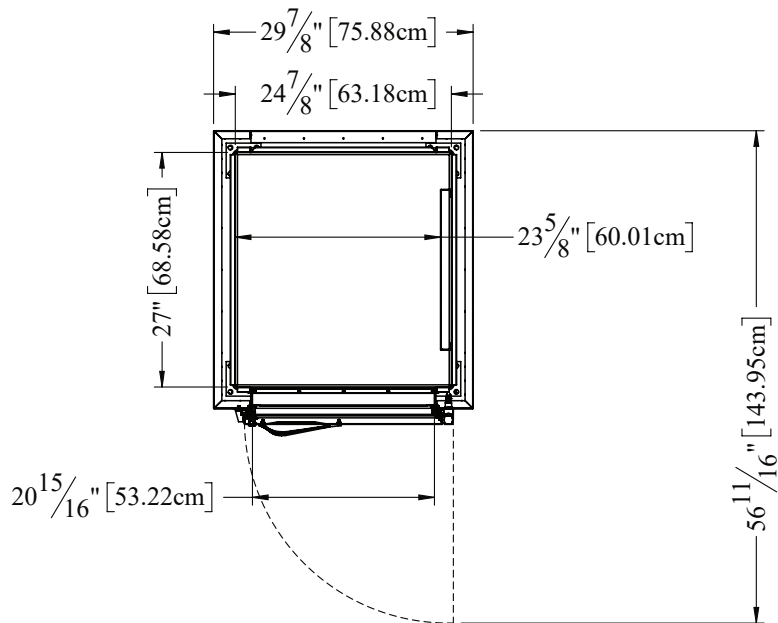

TOP VIEW

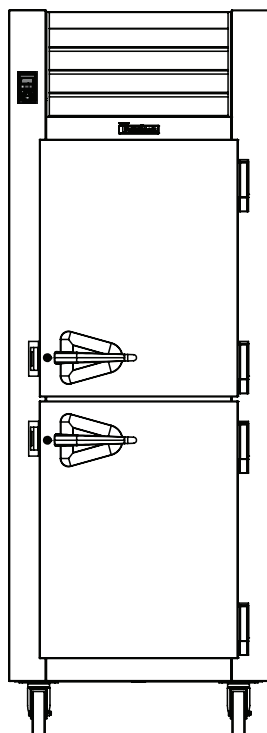

ELEVATION

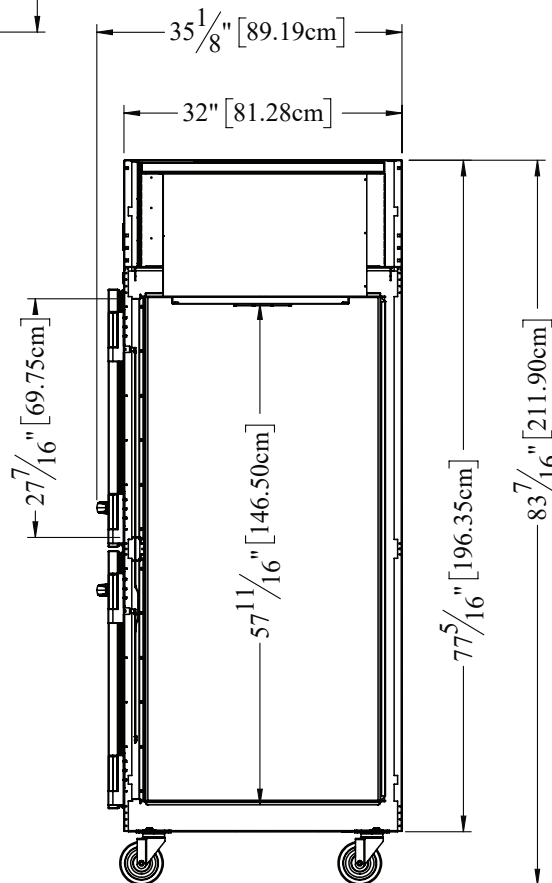

SIDE VIEW

> CAD and/or Revit Files Available

<https://traulsen.klccad.com/>



# R Series

30" Wide Reach-In Refrigerator  
32" Deep, Self-Contained

## MODEL:

RHT132WUT-FHS

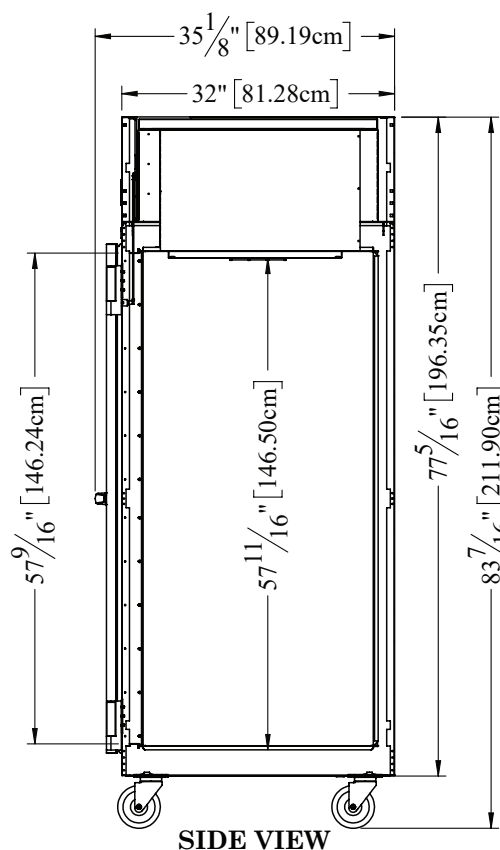
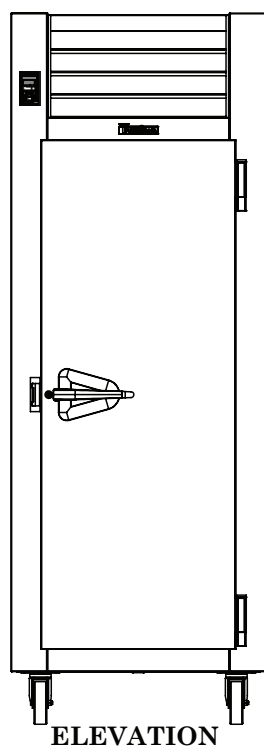
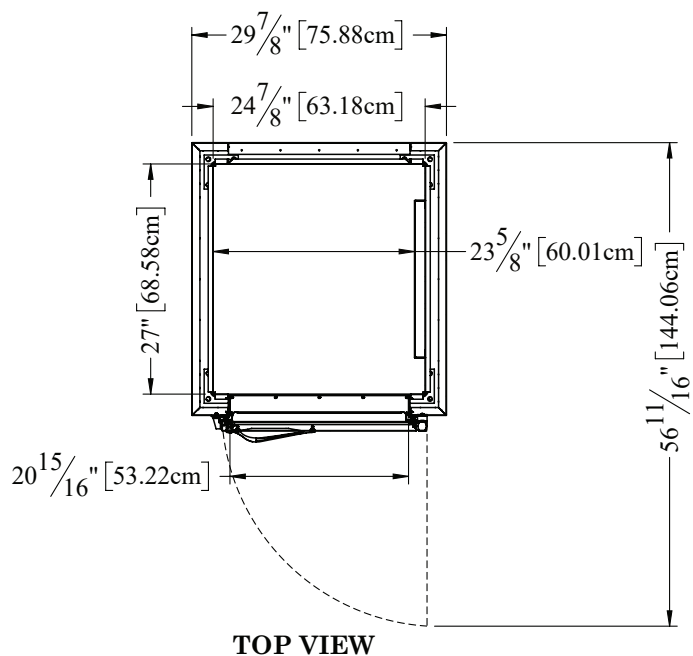

CAD and/or Revit Files Available

<https://traulsen.kclcad.com/>



## R Series

30" Wide Reach-In Refrigerator  
32" Deep, Self-Contained

### MODELS:

RHT132WUT-HHS, RHT132WUT-FHS

MODELS	R/AHT132WUT
<b>DIMENSIONAL DATA</b>	
Net capacity cu. ft.	23.43 (663.5 cu l)
Length - overall in.	29 7/8" (75.9 cm)
Depth - overall in.	35 1/8" (89.2 cm)
Depth - over body in.	32" (81.3 cm)
Depth - door open 90° in.	56 11/16" (144 cm)
Clear door width in.	20 15/16" (53.2 cm)
Clear half-door height in.	27 7/16" (69.7 cm)
Clear full-door height in.	57 9/16" (146.3 cm)
Height - overall on 6" legs <sup>2</sup>	83 7/16" (211.9 cm)
No. Standard Shelves	3
Shelf area sq. ft. <sup>3</sup>	13.46 (1.25 sq. m)
<b>ELECTRICAL DATA</b>	
Voltage   Plug	115/60/1   NEMA 5-15P
Full Load Amperes   KWH/24HR <sup>4</sup>	7.6   1.54
<b>REFRIGERATION DATA</b>	
Refrigerant	R290
Refrigerant Charge Amount oz.	4.8 (136 g)
BTU/HR   H.P. <sup>1</sup>	2875   1/2 HP
<b>SHIPPING DATA</b>	
Length - Crated in.	48" (121.9 cm)
Width - Crated in.	42" (106.7 cm)
Height - Crated in.	85" (215.9 cm)
Volume - Crated cu. ft.	99.17 (2808.2 cu l)
Weight - Crated lbs.	432 (195.9 kg)

**NOTES:** Figures in parentheses reflect metric equivalents.

1. Based on a 90°F ambient and 20°F evaporator.
2. 12" Top clearance preferred for optimum performance & service access.
3. Area of standard shelf compliment only, does not include storage area of additional shelves or available on cabinet bottom.
4. KWH/24 = Kilowatt usage per 24 hours

### EQUIPMENT SPECIFICATIONS

#### CONSTRUCTION, HARDWARE, INSULATION

The interior is made from stainless steel and the cabinet exterior front, one piece sides, louver assembly, door and door liner is constructed of heavy gauge stainless steel. The exterior cabinet top, back and bottom is constructed of heavy gauge galvanized steel. A set of four (4) adjustable 6" high stainless steel legs are included.

Door is equipped with a gasket-protecting metal door pan, removable plug cylinder locks & guaranteed for life gravity action, self-closing metal, cam-lift hinges with a stay open feature. Hinges include a concealed switch to automatically activate the interior LED lighting. Guaranteed for life, workflow door handle is mounted horizontally over recess in door which limits protrusion from door face into aiseways. Doors have seamless, polished metal corners.

Gasket profile & EZ-Clean™ material simplify cleaning & increase overall gasket life. Anti-condensate heaters are located behind the door opening. Both the cabinet & door is insulated with an average of 2" thick high density, non-CFC, foamed in place polyurethane.

#### SELF-CONTAINED REFRIGERATION SYSTEM

A top mounted, self-contained, balanced refrigeration system using environmentally friendly, low GWP R290 refrigerant is conveniently located behind the one piece louver assembly. It features a finless StayClear™ condenser, thermostatic expansion valve, air-cooled, hermetic variable speed compressor, large, high humidity evaporator coil located outside the food zone & top mounted non-electric condensate evaporator. A 9' cord & plug is provided. Standard operating temperature is 34-38°F.

#### CONTROL

Traulsen's Smart Control™ features advanced control algorithms & sophisticated diagnostic capabilities to optimize performance. Utilizing smart sensors, it adapts the operation of the refrigeration system to a variety of environments & usage patterns. The Smart Control™ also offers a complete set of visual alarms designed to alert the user to critical events such as power outages or a prolonged door opening. In the event of an alarm, a dedicated Alarm LED will illuminate, informing the user of the critical event and duration.

#### INTERIOR

Standard interior arrangements include three (3) coated wire shelves per section, mounted on shelf pins. Shelves are full-width & do not have any large gaps between them requiring the use of "bridge" or "junior" shelves. Recommended load limit per shelf should not exceed 225 lbs. Interior arrangements are installed at the factory.

#### WARRANTY

Both a six year parts and labor warranty and a seven year compressor warranty (self-contained models only) are provided standard.

When ordering please specify: Voltage, Hinging, and Options.

Equipped with one NEMA 5-15P Plug



CONTINUED PRODUCT DEVELOPMENT MAY NECESSITATE SPECIFICATION CHANGES WITHOUT NOTICE.



Project \_\_\_\_\_  
 AIA # \_\_\_\_\_ SIS # \_\_\_\_\_  
 Item # \_\_\_\_\_ Quantity \_\_\_\_\_ C.S.I. Section 114000



BLAST CHILLER ACCESSORIES

## TBC-SERIES

### Optional Condensate Evaporators for Models TBC13, TBC1H/TBC1HR & TBC2H/TBC2HR

#### Description of Purpose

Designed for use with the above models in order to provide condensate removal in lieu of a floor drain. Each includes a two-piece stainless steel upper and lower housing, which provides protection from damaging impacts, and a thermally activated evaporative pan with 9 foot cord and plug (requires provision of a separate electrical outlet) for models TBC1H, TBC1HR, TBC2H & TBC2HR. Note: On model TBC13 this can be mounted to the cabinet bottom, however for models TBC1H, TBC1HR, TBC2H & TBC2HR these are installed inside of a compartment at the cabinet bottom.

ACCESSORY	TBCACC-60018 (for all roll-in/roll-thru models only)
<b>Floor Mounted Condensate Evaporator</b>	
L x D x H - Overall in.	13 1/8 (33.3 cm) x 5 1/8 (12.9 cm) x 3 1/2 (8.9 cm)
NEMA Plug (3 wire with ground)	5-15 P (9' cord)
Voltage	115/60/1
Full Load Amps	1.5

**NOTE: Plug requires separate electrical outlet.**

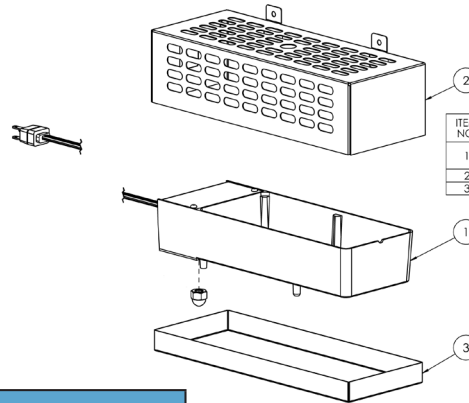

ITEM NO.	PART NUMBER	DESCRIPTION	Default/Qty.
1	329-60072-01	117V EL. CONDENSATE EVAPORATOR W/ 120' CORD	1
2	701-60143-00	CONDENSATE EVAP. EXT. COVER	1
3	701-60144-00	COND. EVAPORATOR BTM COVER	1

ACCESSORY	TBCACC-BMCE (for TBC13 model only)
<b>Bottom Mounted Condensate Evaporator</b>	
L x D x H - Overall in.	12 1/2 (31.73 cm) x 4 7/8 (12.4 cm) x 4 7/8 (10.5 cm)
Plug (3 wire with ground)	Plugs into Receptacle on Rear of Unit (18" cord)
Voltage	220/60/1
Full Load Amps	1.4

**NOTE: On model TBC13 the cabinet includes provisions for mounting the condensate evaporator to the cabinet bottom. This includes an outlet located on the cabinet bottom and pre-drilled mounting holes on the cabinet bottom.**

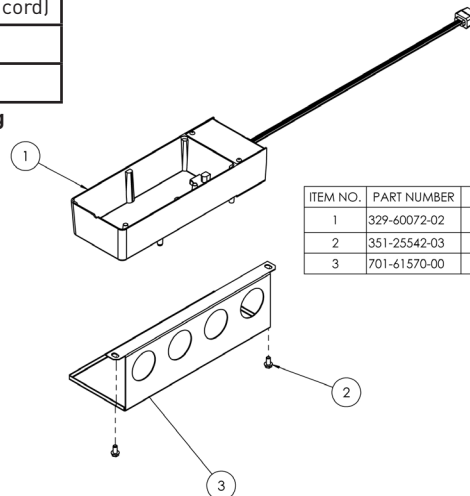

ITEM NO.	PART NUMBER	DESCRIPTION	QTY.
1	329-60072-02	220V EL. CONDENSATE EVAPORATOR W/18' CORD	1
2	351-25542-03	1/4-20 X 1/2 HWH MACHINE SCREW	2
3	701-61570-00	BMCE BRACKET TBC13	1

Approved by \_\_\_\_\_ Date \_\_\_\_\_ Approved by \_\_\_\_\_ Date \_\_\_\_\_



## TBC-SERIES

Blast Chiller, Optional Roll-In Rack  
for Models TBC1H/TBC1HR & TBC2H/TBC2HR

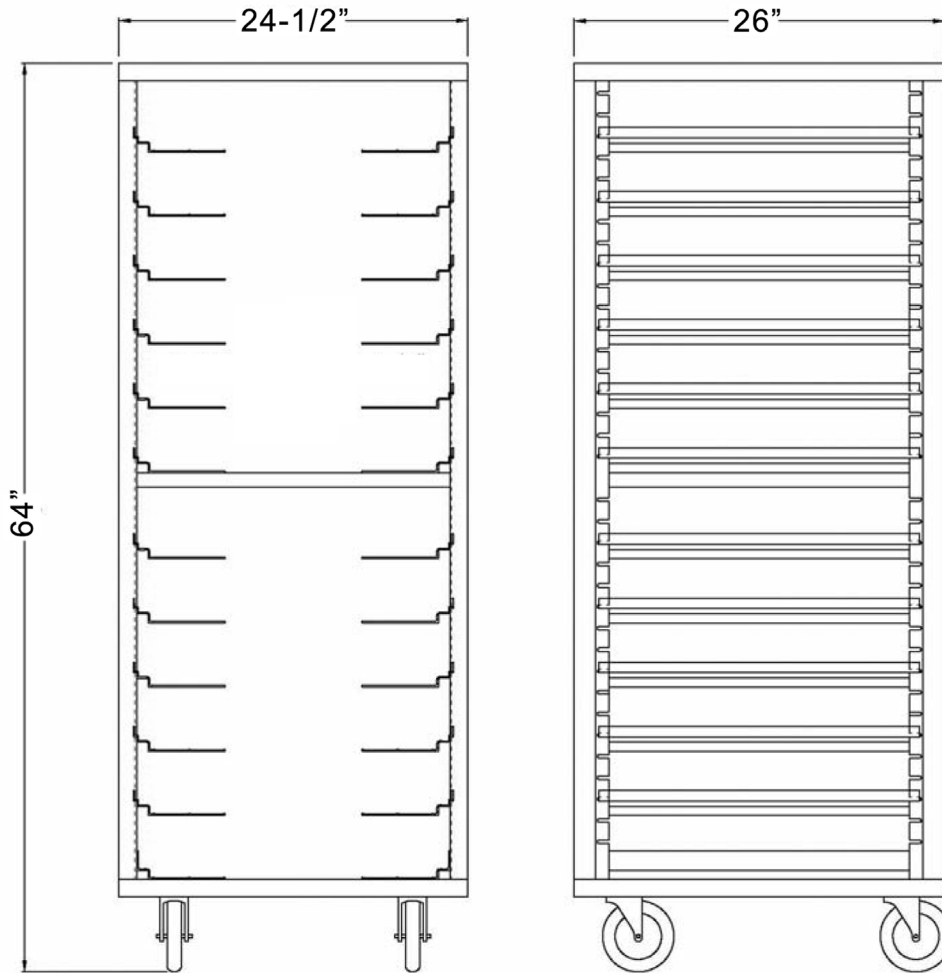

ACCESSORY	TBCACC-OTRTR (for all roll-in/roll-thru models only)
<b>OPTIONAL ROLL-IN RACK - PART# 342-60132-00</b>	
Length in.	24-1/2" (62.0 cm)
Depth in.	26" (66.0 cm)
Height in.	64" (162.5 cm)
Capacity 12"x20"x2-1/2"	24 Pans
Capacity 18"x26"	12 Sheet Pans
Capacity 14"x18"	24 Sheet Pans

#### CONSTRUCTION & HARDWARE:

Welded construction with casters. Provided with adjustable Universal Tray Slides. Roll-In Rack provides maximum chill performance, with open sides for optimum airflow.



Project \_\_\_\_\_  
 AIA # \_\_\_\_\_ SIS # \_\_\_\_\_  
 Item # \_\_\_\_\_ Quantity \_\_\_\_\_ C.S.I. Section 114000

## R Series

30" Wide Pass-Thru Refrigerator Model  
 Solid Door, 32" Deep, Self-Contained



### STANDARD PRODUCT FEATURES

- Stainless Steel Exterior & Interior
- Variable Speed Compressor Adapts to the Specific Work Environment
- Traulsen's Smart Control™ with LED Display
- StayClear™ Condenser Coil
- Balanced, Self-Contained Refrigeration System Using R-290 Refrigerant
- Full or Half-Height Stainless Steel Doors with Lock(s)
- Anti-Condensate Door Perimeter Heater
- Self-Closing Doors with Stay Open Feature
- Standard Door Hinging F & R: 132WP = Right (other hings available)
- Automatically Activated LED Lights
- Stainless Steel Breaker Caps
- Three Adjustable, Coated Wire Shelves Per Section, Supported on Shelf Pins (factory installed)
- Automatic Non-Electric Condensate Evaporator
- Magnetic Snap-In EZ-Clean™ Door Gasket(s)
- Gasket-Protecting Door Liner(s)
- Thermostatic Expansion Valve Metering Device
- Stainless Steel One-Piece Louver Assembly
- 9' Cord & Plug Attached
- Set of (4) 6" High Adjustable Stainless Steel Legs

### ACCESSORIES & OPTIONS

- SmartConnect™ Monitoring App with Wi-Fi Connectivity
- Accommodates EZ-Clean™ Tray Racks
- #1 Type Trayslides to Accommodate (1) 18" x 26" or (2) 14" x 18" Pans
- #4 Type Trayslides to Accommodate 18 to 19 Levels for 18" x 26" Pans
- Universal Type Trayslides to Accommodate (1) 18" x 26" or (2) 14" x 18" Sheet Pans, or (2) 12" x 20" Steam Table Pans
- Additional Coated Wire or Optional Stainless Steel Shelves
- EZ-Open™ Foot Pedal (full height doors only)
- Locking Hasps (padlocks supplied by others)
- Optional 208/115/60/1, 208-230/60/1, or Export 220/50/1 Voltage
- Kool Klad™ Exterior Laminate Decor
- Set of (4) 4 1/8" or 6" High Casters in Lieu of Legs
- Other Support Options: 4 1/2" High Base or 6" High Kickplate (for use with standard legs)
- Clear Glass Door(s) in Place of Solid Door(s)



Models listed to the applicable UL, CSA and NSF standards by an approved NRTL. Consult the factory or unit data plate for additional information.

### AVAILABLE CONFIGURATIONS

#### R Series Models

RHT132WPUT-FHS  
 RHT132WPUT-HHS

#### Door(s)

Full Height Solid  
 Half Height Solid

**- GUARANTEED FOR LIFE CAM-LIFT HINGES**  
**- GUARANTEED FOR LIFE HORIZONTAL WORKFLOW DOOR HANDLES**

**\*Remote application without R-290 refrigerant available, see form TR35837 for details.**



ENERGY STAR® Listed Commercial Refrigerator  
 For full listing visit [energystar.gov](http://energystar.gov)



# R Series

30" Wide Pass-Thru Refrigerator  
Solid Door, 32" Deep, Self-Contained

### MODELS:

RHT132WPUT-HHS, RHT132WPUT-FHS

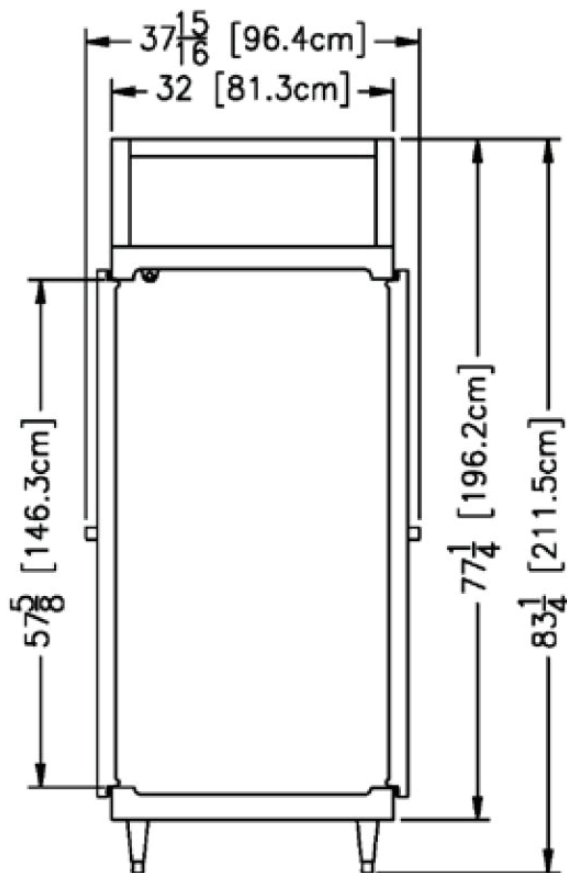
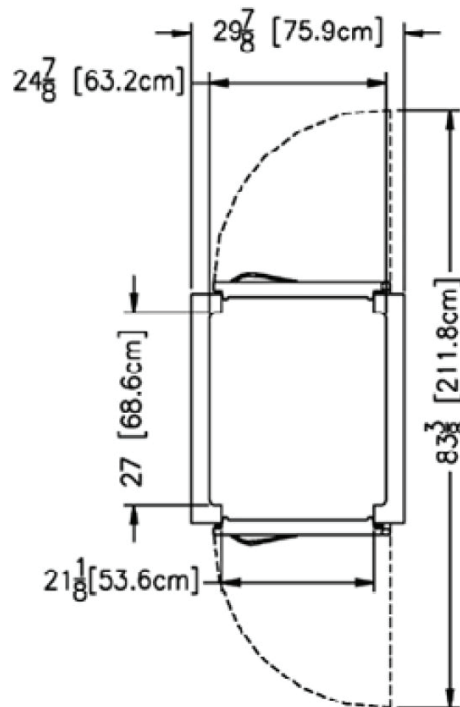
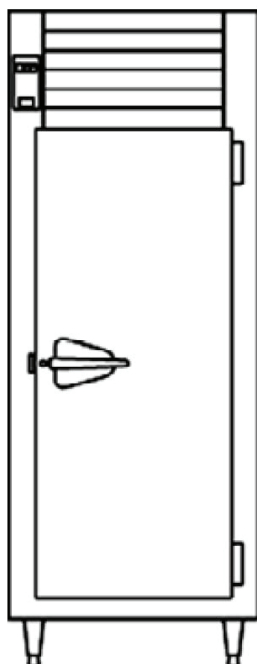

CAD and/or Revit Files Available  
<https://traulsen.klclcad.com/>



## R Series

30" Wide Pass-Thru Refrigerator  
Solid Door, 32" Deep, Self-Contained

### MODELS:

RHT132WPUT-HHS, RHT132WPUT-FHS

MODELS	RHT132WPUT
<b>DIMENSIONAL DATA</b>	
Net capacity cu. ft.	24.86 (704 cu l)
Length - overall in.	29 7/8" (75.9 cm)
Depth - overall in.	37 15/16" (96.4 cm)
Depth - over body in.	32" (81.3 cm)
Depth - door open 90° in.	83 3/8" (211.8 cm)
Clear door width in.	21 1/8" (53.6 cm)
Clear half-door height in.	27 1/2" (69.9 cm)
Clear full-door height in.	57 5/8" (146.3 cm)
Height - overall on 6" legs <sup>2</sup>	83 1/4" (211.5 cm)
No. Standard Shelves	3
Shelf area sq. ft. <sup>3</sup>	13.46 (1.25 sq. m)
<b>ELECTRICAL DATA</b>	
Voltage   Plug	115/60/1   NEMA 5-15P
Full Load Amperes   KWH/24HR <sup>4</sup>	7.6   1.6
<b>REFRIGERATION DATA</b>	
Refrigerant	R290
Refrigerant Charge Amount oz.	4.8 (136 g)
BTU/HR   H.P. <sup>1</sup>	2875   1/2 HP
<b>SHIPPING DATA</b>	
Length - Crated in.	48" (121.9 cm)
Width - Crated in.	42" (106.7 cm)
Height - Crated in.	85" (215.9 cm)
Volume - Crated cu. ft.	99.17 (2808.2 cu l)
Weight - Crated lbs.	470 (213.2 kg)

**NOTES:** Figures in parentheses reflect metric equivalents.

1. Based on a 90°F ambient and 20°F evaporator.
2. 12" Top clearance preferred for optimum performance & service access.
3. Area of standard shelf compliment only, does not include storage area of additional shelves or available on cabinet bottom.
4. KWH/24HR = Kilowatts usage per 24 hours

### EQUIPMENT SPECIFICATIONS

#### CONSTRUCTION, HARDWARE, INSULATION

The interior is made from stainless steel and the cabinet exterior front, one piece sides, louver assembly, doors and door liners are constructed of heavy gauge stainless steel. The exterior cabinet top and bottom are constructed of heavy gauge galvanized steel. Included is a set of four adjustable 6" stainless steel legs.

Doors have removable plug cylinder locks & guaranteed for life gravity action, self-closing cam-lift hinges with a stay-open feature. An external switch is included to activate interior LED lighting. The gasket design simplifies cleaning & enhances longevity. Anti-condensate heaters are located behind each door opening.

The unit has seamless, polished metal corners & guaranteed for life workflow door handles mounted horizontally over recess in door which limits protrusion from door face into aisles. The cabinet is insulated with high density, non-CFC, foamed in place polyurethane.

#### SELF-CONTAINED REFRIGERATION SYSTEM

The unit uses a top-mounted, balanced system located behind the one piece louver assembly. The R290 refrigerant is environmentally friendly & has a low GWP. It features a finless StayClear™ condenser, thermostatic expansion valve, air-cooled, hermetic variable speed compressor, plenum effect blower coil, large, high humidity evaporator coil outside the food zone & a top-mounted non-electric condensate evaporator. Operating temperatures are 34-38°F. A 9' cord and plug are provided.

#### CONTROL

Traulsen's Smart Control™ features advanced control algorithms & sophisticated diagnostic capabilities to optimize performance. Utilizing smart sensors, it adapts the operation of the refrigeration system to a variety of environments & usage patterns. The Smart Control™ also offers a complete set of visual alarms designed to alert the user to critical events such as power outages or a prolonged door opening. In the event of an alarm, a dedicated Alarm LED will illuminate, informing the user of the critical event and duration.

#### INTERIOR

The interior includes three factory installed pin-mounted, full-width coated wire shelves per section with no large gaps. Each shelf can support up to 225 lbs. Factory installed optional trayslides may be purchased in combination with, or in lieu of these.

#### WARRANTY

Both a six year parts & labor warranty and a seven year compressor warranty (self-contained models only) are provided standard.

When ordering please specify: Voltage, Hinging, and Options

Equipped with one NEMA 5-15P Plug





Project \_\_\_\_\_  
 AIA # \_\_\_\_\_ SIS # \_\_\_\_\_  
 Item # \_\_\_\_\_ Quantity \_\_\_\_\_ C.S.I. Section 114000



BLAST CHILLER ACCESSORIES

## TBC-SERIES

### Optional Condensate Evaporators for Models TBC13, TBC1H/TBC1HR & TBC2H/TBC2HR

#### Description of Purpose

Designed for use with the above models in order to provide condensate removal in lieu of a floor drain. Each includes a two-piece stainless steel upper and lower housing, which provides protection from damaging impacts, and a thermally activated evaporative pan with 9 foot cord and plug (requires provision of a separate electrical outlet) for models TBC1H, TBC1HR, TBC2H & TBC2HR. Note: On model TBC13 this can be mounted to the cabinet bottom, however for models TBC1H, TBC1HR, TBC2H & TBC2HR these are installed inside of a compartment at the cabinet bottom.

ACCESSORY	TBCACC-60018 (for all roll-in/roll-thru models only)
<b>Floor Mounted Condensate Evaporator</b>	
L x D x H - Overall in.	13 1/8 (33.3 cm) x 5 1/8 (12.9 cm) x 3 1/2 (8.9 cm)
NEMA Plug (3 wire with ground)	5-15 P (9' cord)
Voltage	115/60/1
Full Load Amps	1.5

**NOTE: Plug requires separate electrical outlet.**

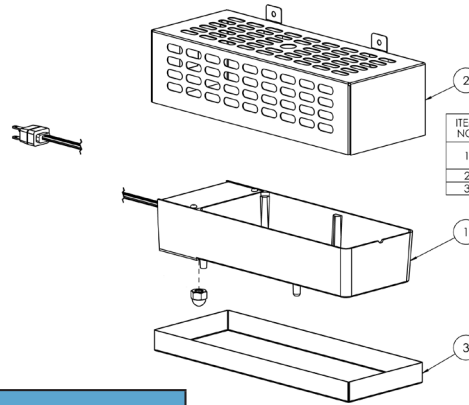

ITEM NO.	PART NUMBER	DESCRIPTION	Default/ QTY.
1	329-60072-01	117V EL. CONDENSATE EVAPORATOR W/ 120' CORD	1
2	701-60143-00	CONDENSATE EVAP. EXT. COVER	1
3	701-60144-00	COND. EVAPORATOR BTM COVER	1

ACCESSORY	TBCACC-BMCE (for TBC13 model only)
<b>Bottom Mounted Condensate Evaporator</b>	
L x D x H - Overall in.	12 1/2 (31.73 cm) x 4 7/8 (12.4 cm) x 4 1/8 (10.5 cm)
Plug (3 wire with ground)	Plugs into Receptacle on Rear of Unit (18" cord)
Voltage	220/60/1
Full Load Amps	1.4

**NOTE: On model TBC13 the cabinet includes provisions for mounting the condensate evaporator to the cabinet bottom. This includes an outlet located on the cabinet bottom and pre-drilled mounting holes on the cabinet bottom.**

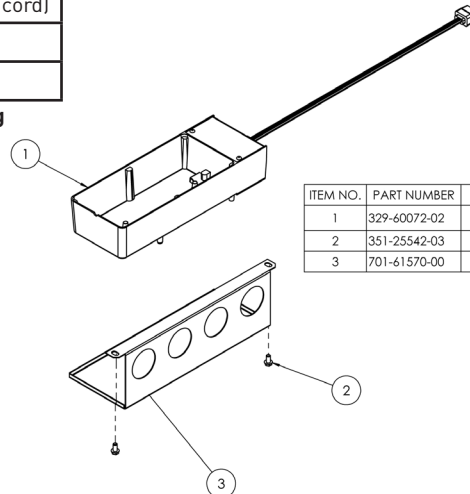

ITEM NO.	PART NUMBER	DESCRIPTION	QTY.
1	329-60072-02	220V EL. CONDENSATE EVAPORATOR W/18' CORD	1
2	351-25542-03	1/4-20 X 1/2 HWH MACHINE SCREW	2
3	701-61570-00	BMCE BRACKET TBC13	1

Approved by \_\_\_\_\_ Date \_\_\_\_\_ Approved by \_\_\_\_\_ Date \_\_\_\_\_



## TBC-SERIES

Blast Chiller, Optional Roll-In Rack  
for Models TBC1H/TBC1HR & TBC2H/TBC2HR

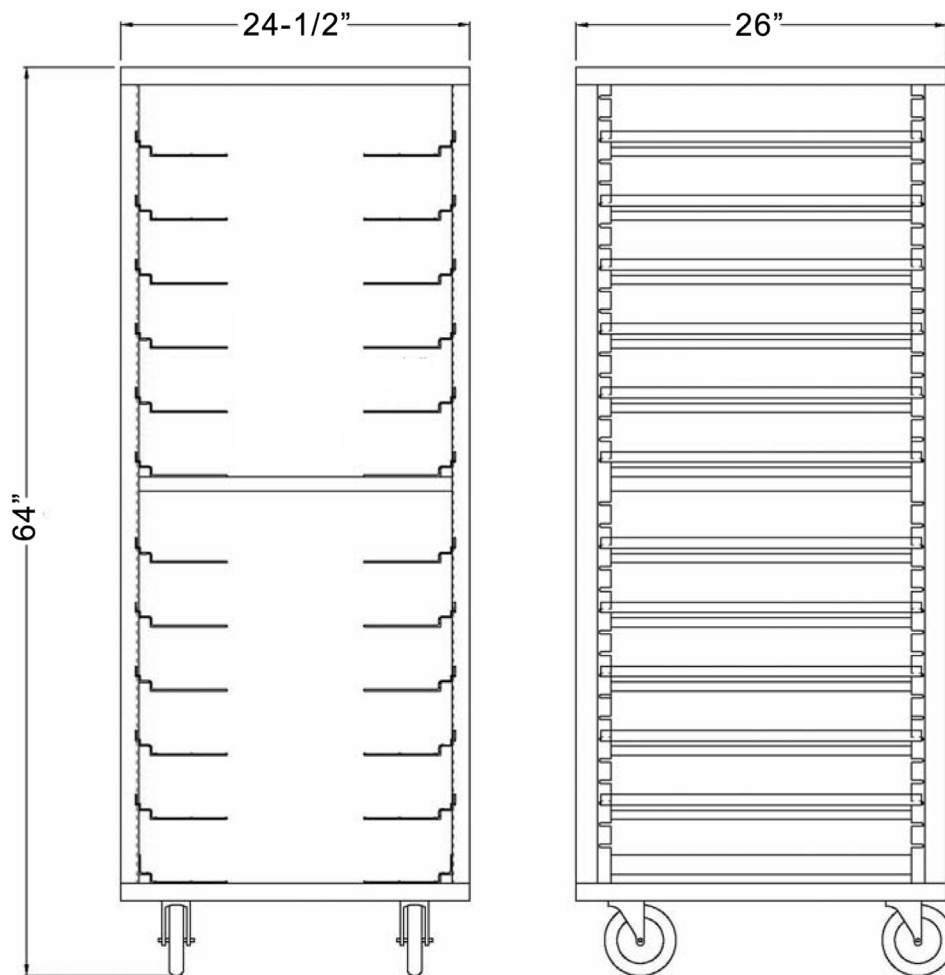

ACCESSORY	TBCACC-OTRTR (for all roll-in/roll-thru models only)
<b>OPTIONAL ROLL-IN RACK - PART# 342-60132-00</b>	
Length in.	24-1/2" (62.0 cm)
Depth in.	26" (66.0 cm)
Height in.	64" (162.5 cm)
Capacity 12"x20"x2-1/2"	24 Pans
Capacity 18"x26"	12 Sheet Pans
Capacity 14"x18"	24 Sheet Pans

#### CONSTRUCTION & HARDWARE:

Welded construction with casters. Provided with adjustable Universal Tray Slides. Roll-In Rack provides maximum chill performance, with open sides for optimum airflow.



## G-SERIES ACCESSORY KITS

### 1 Section Models

#### G-Series Accessory Kit Location Guide:

Each kit includes all necessary mounting hardware except where noted. All G-Series accessory kits are pre-packaged for easy installation at the job site.

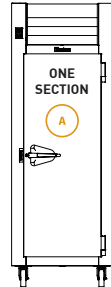

One Section Models

A

#### TRAYSLIDES

- G1ACC-TK1
- G1ACC-TK2
- G1ACC-TK4
- G13ACC-1EZ
- G13ACC-UEZ
- G13ACC-HDUEZ

#### SHELVES

- G1ACC-SHLF1
- G1ACC-SHLF2
- G1ACC-SHLF5
- G1ACC-BTL5
- G12ACC-BTL1

DESCRIPTION	MODEL	HEATED CABINET	REFRIG. / FREEZER
<b>EZ-CHANGE KITS</b>			
(4) pairs #1 trayslides with pilasters per 1/2 section (top or bottom)	<b>G13ACC-1EZ</b>	Available	Available
(3) pairs universal with pilasters per 1/2 section (top or bottom)	<b>G13ACC-UEZ</b>	Available	Available
(3) pairs heavy duty universal with pilasters per 1/2 section (top or bottom)	<b>G13ACC-HDUEZ</b>	Available	Available
<b>TRAYSLIDES</b>			
(8) pairs #1 trayslides includes pilasters per full section	<b>G1ACC-TK1</b>	Available	Available
(2) pairs #4 trayslides includes pilasters per full section	<b>G1ACC-TK2</b>	Available	Available
(7) pairs universal trayslides includes pilasters per full section	<b>G1ACC-TK4</b>	Available	Available
<b>SHELVES</b>			
(3) epoxy coated shelves on pins	<b>G1ACC-SHLF1</b>	Not Available	Available
(3) epoxy coated shelves on pilasters	<b>G1ACC-SHLF2</b>	Not Available	Available
(1) epoxy coated shelf with pins & clips	<b>G1ACC-SHLF5</b>	Not Available	Available
(5) bottle shelves with mounting hardware (glass door models only)	<b>G1ACC-BTL5</b>	Not Available	Available
(1) bottle shelf with clips without mounting hardware (glass door models only)	<b>G12ACC-BTL1</b>	Not Available	Available

### OPTIONS

DESCRIPTION	PRICE
Export Crating	Available

### OTHER ACCESSORY KITS – FOR ALL G-SERIES REFRIGERATOR, FREEZER & HEATED MODELS

DESCRIPTION	MODEL	PRICE
Set of (4) 6" high legs	<b>GSACC-LEGS</b>	Available
Set of (4) 6" high casters	<b>CK1</b>	Available
Set of (4) 4-5/8" high casters	<b>CK3</b>	Available
Set of (4) 2-3/4" high casters	<b>CK14</b>	Available
Set of (4) 6" stainless steel flanged legs	<b>LK3</b>	Available
(1) pair #1 type trayslides (Must order pilasters. Consult factory for other trayslide and pilaster kit options.)	<b>GSACC-#1TS</b>	Available
(1) pair #4 type trayslides (Must order pilasters. Consult factory for other trayslide and pilaster kit options.)	<b>GSACC-#4TS</b>	Available
(1) pair universal type trayslides (Must order pilasters. Consult factory for other trayslide and pilaster kit options.) (excludes 2 section heated cabinets only)	<b>GSACC-UVTS</b>	Available
(1) pair EZ-Change #1 type trayslides (Must order pilasters. Consult factory for other trayslide and pilaster kit options.)	<b>GSACC-1EZ</b>	Available
(1) pair EZ-Change universal type trayslides (Must order pilasters. Consult factory for other tray slide and pilaster kit options.)	<b>GSACC-UEZ</b>	Available
(1) pair EZ-Change heavy duty universal type trayslides (Must order pilasters. Consult factory for other trayslide and pilaster kit options.)	<b>GSACC-HDUEZ</b>	Available
(1) set pilasters and clips for shelves (Not applicable for trayslides)	<b>GSACC-PLSTS</b>	Available



## G-SERIES ACCESSORY KITS

### 2 Section Models

#### G-Series Accessory Kit Location Guide:

Each kit includes all necessary mounting hardware except where noted. All G-Series accessory kits are pre-packaged for easy installation at the job site.

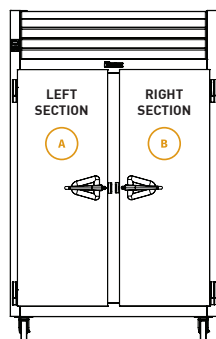

Two Section Models

#### TRAYSLIDES

- G23ACC-TK1LR
- G23ACC-TK2LR
- G23ACC-TK4LR
- G23ACC-1EZ
- G23ACC-UEZ
- G23ACC-HDUEZ

#### SHELVES

- G23ACC-SHLF1
- G23ACC-SHLF2
- G23ACC-SHLF9
- G2ACC-BTL5

#### TRAYSLIDES

- G23ACC-TK1LR
- G23ACC-TK2LR
- G23ACC-TK4LR
- G23ACC-1EZ
- G23ACC-UEZ
- G23ACC-HDUEZ

#### SHELVES

- G23ACC-SHLF5
- G23ACC-SHLF6
- G23ACC-SHLF11
- G2ACC-BTL5

DESCRIPTION	MODEL	HEATED CABINET	REFRIG. / FREEZER
<b>EZ-CHANGE KITS</b>			
<b>LEFT AND RIGHT SECTION:</b>			
(4) pairs #1 trayslides with pilasters per ½ section (top and bottom)	<b>G23ACC-1EZ</b>	Not Available	Available
(3) pairs universal with pilasters per ½ section (top and bottom)	<b>G23ACC-UEZ</b>	Not Available	Available
(3) pairs heavy duty universal with pilasters per ½ section (top and bottom)	<b>G23ACC-HDUEZ</b>	Not Available	Available
<b>TRAY SLIDES</b>			
<b>LEFT AND RIGHT SECTION:</b>			
(8) pairs #1 trayslides (with pilasters) per full section	<b>G23ACC-TK1LR</b>	Not Available	Available
(2) pairs #4 trayslides (with pilasters) per full section	<b>G23ACC-TK2LR</b>	Not Available	Available
(7) pairs universal trayslides (with pilasters) per full section	<b>G23ACC-TK4LR</b>	Available	Available
<b>SHELVES</b>			
<b>LEFT SECTION:</b>			
(3) epoxy coated shelves on pins	<b>G23ACC-SHLF1</b>	Not Available	Available
(3) epoxy coated shelves on pilasters	<b>G23ACC-SHLF2</b>	Not Available	Available
(1) epoxy coated shelf with pins & clips	<b>G23ACC-SHLF9</b>	Not Available	Available
<b>RIGHT SECTION:</b>			
(3) epoxy coated shelves on pins	<b>G23ACC-SHLF5</b>	Not Available	Available
(3) epoxy coated shelves on pilasters	<b>G23ACC-SHLF6</b>	Not Available	Available
(1) epoxy coated shelf with pins & clips	<b>G23ACC-SHLF11</b>	Not Available	Available
<b>LEFT OR RIGHT SECTION:</b>			
(1) plated shelf with pins & clips (hot food cabinets only)	<b>G23ACC-SHLF13</b>	Available	Not Available
(5) bottle shelves with mounting hardware (Glass door models only. Fits 1 section of a 2 section unit. Requires 2 kits to outfit both sections.)	<b>G2ACC-BTL5</b>	Not Available	Available

### OPTIONS

DESCRIPTION	PRICE
Export Crating	Available



## G-SERIES ACCESSORY KITS

### 3 Section Models

#### G-Series Accessory Kit Location Guide:

Each kit includes all necessary mounting hardware except where noted. All G-Series accessory kits are pre-packaged for easy installation at the job site.

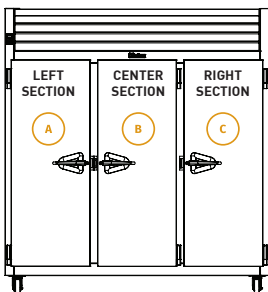

Three Section Models

A		B		C	
TRAYSLIDES	SHELVES	TRAYSLIDES	SHELVES	TRAYSLIDES	SHELVES
■ G23ACC-TK1LR	■ G23ACC-SHLF1	■ G3ACC-TK1C	■ G3ACC-SHLF5	■ G23ACC-TK1LR	■ G23ACC-SHLF5
■ G23ACC-TK2LR	■ G23ACC-SHLF2	■ G3ACC-TK2C	■ G3ACC-SHLF6	■ G23ACC-TK2LR	■ G23ACC-SHLF6
■ G23ACC-TK4LR	■ G23ACC-SHLF9	■ G3ACC-TK4C	■ G3ACC-SHLF15	■ G23ACC-TK4LR	■ G23ACC-SHLF11
■ G23ACC-1EZ	■ G3ACC-BTL5-LR	■ G13ACC-1EZ	■ G3ACC-BTL5-C	■ G23ACC-1EZ	■ G3ACC-BTL5-LR
■ G23ACC-UEZ		■ G13ACC-UEZ		■ G23ACC-UEZ	
■ G23ACC-HDUEZ		■ G13ACC-HDUEZ		■ G23ACC-HDUEZ	

DESCRIPTIONS	MODEL	REFRIG. / FREEZER
<b>EZ-CHANGE KITS: (DOES NOT APPLY TO G-SERIES HEATED CABINETS)</b>		
<b>LEFT AND RIGHT SECTIONS:</b>		
(4) pairs #1 trayslides with pilasters per 1/2 section (top and bottom)	<b>G23ACC-1EZ</b>	Available
(3) pairs universal with pilasters per 1/2 section (top and bottom)	<b>G23ACC-UEZ</b>	Available
(3) pairs heavy duty universal with pilasters per 1/2 section (top and bottom)	<b>G23ACC-HDUEZ</b>	Available
<b>CENTER SECTION:</b>		
(4) pairs #1 trayslides with pilasters per 1/2 section (top and bottom)	<b>G13ACC-1EZ</b>	Available
(3) pairs universal with pilasters per 1/2 section (top and bottom)	<b>G13ACC-UEZ</b>	Available
(3) pairs heavy duty universal with pilasters per 1/2 section (top and bottom)	<b>G13ACC-HDUEZ</b>	Available
<b>TRAYSLIDES: (DOES NOT APPLY TO G-SERIES HEATED CABINETS)</b>		
<b>LEFT AND RIGHT SECTIONS:</b>		
(8) pairs #1 trayslides (with pilasters) per full section	<b>G23ACC-TK1LR</b>	Available
(2) pairs #4 trayslides (with pilasters) per full section	<b>G23ACC-TK2LR</b>	Available
(7) pairs universal trayslides (with pilasters) per full section	<b>G23ACC-TK4LR</b>	Available
<b>CENTER SECTION:</b>		
(8) pairs #1 trayslides (with pilasters) per full section	<b>G3ACC-TK1C</b>	Available
(2) pairs #4 trayslides (with pilasters) per full section	<b>G3ACC-TK2C</b>	Available
(7) pairs universal trayslides (with pilasters) per full section	<b>G3ACC-TK4C</b>	Available
<b>SHELVES: (DOES NOT APPLY TO G-SERIES HEATED CABINETS)</b>		
<b>LEFT SECTION:</b>		
(3) epoxy coated shelves on pins	<b>G23ACC-SHLF1</b>	Available
(3) epoxy coated shelves on pilasters	<b>G23ACC-SHLF2</b>	Available
(1) epoxy coated shelf with pins & clips (for Left Section)	<b>G23ACC-SHLF9</b>	Available
<b>CENTER SECTION:</b>		
(3) epoxy coated shelves on pins	<b>G3ACC-SHLF5</b>	Available
(3) epoxy coated shelves on pilasters	<b>G3ACC-SHLF6</b>	Available
(1) epoxy coated shelf with pins & clips (for Center Section)	<b>G3ACC-SHLF15</b>	Available
(5) bottle shelves with mounting hardware (glass door models only)	<b>G3ACC-BTL5-C</b>	Available
<b>RIGHT SECTION:</b>		
(3) epoxy coated shelves on pins	<b>G23ACC-SHLF5</b>	Available
(3) epoxy coated shelves on pilasters	<b>G23ACC-SHLF6</b>	Available
(1) epoxy coated shelf with pins & clips (for Right Section)	<b>G23ACC-SHLF11</b>	Available
<b>LEFT OR RIGHT SECTION:</b>		
(5) bottle shelves with mounting hardware (Glass door models only. Fits Left or Right section of a 3 section unit. Requires 2 kits to outfit both Left and Right sections.)	<b>G3ACC-BTL5-LR</b>	Available

### OPTIONS

DESCRIPTIONS	PRICE
Export Crating	Available



# G-SERIES ACCESSORY KITS

## Trayslide & Shelf Versatility Chart

### TRAYSLIDES

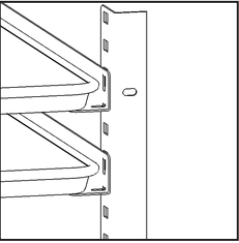
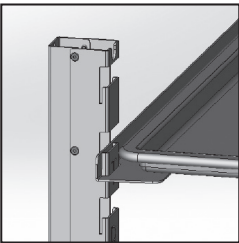
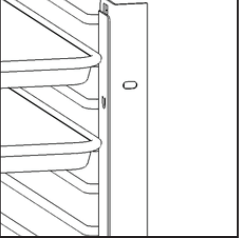
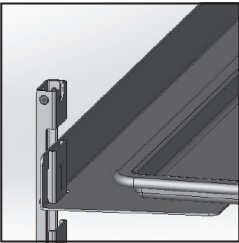
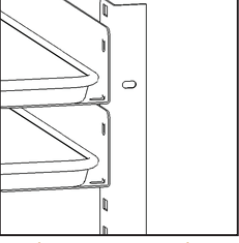
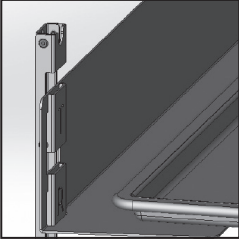
TRAYSLIDES	EZ-CHANGE TRAYSLIDES
 <p><b>#1 Trayslides Standard</b></p>	 <p><b>#1 Trayslides EZ-Change</b></p>
 <p><b>#4 Trayslides Standard</b></p>	 <p><b>Universal Trayslides EZ-Change</b></p>
 <p><b>Universal Trayslides Standard</b></p>	 <p><b>Heavy-Duty Universal Trayslides EZ-Change</b></p>

- NOTES:**
- For all after market parts call Traulsen parts department 800-825-8220.
  - The above quantities represent the maximum amount of tray slides recommended by Traulsen to achieve best air circulation and refrigeration performance.
  - Optional trayslides are not available for Compact Undercounter, and Prep Tables models
  - EZ-Change Interior Universal Trayslides max weight 75 lbs. EZ-Change Heavy Duty Universal Trayslides max weight 125 lbs.
  - #1, #4, universal and HD universal EZ change trayslides are not available for 2 section G Series heated cabinets.\*
  - All G-Series accessory kits are pre-packaged for easy installation at the job site.

DESCRIPTION	SPACING			
<b>#1 TRAYSLIDES (NOT AVAILABLE FOR 2 SECTION G HEATED)*</b>				
<b>16 ga. stainless steel angle type for bottom support of:</b> (1) 18" x 26" Pan or (2) 14" x 18" Pans	<b>2"</b>	<b>3"</b>	<b>4"</b>	<b>5"</b>
Behind full height door – all models	28	19	14	11
Behind upper half height door – all models	13	9	7	5
Behind lower half height door – all models	13	9	7	5
<b>#1 Trayslides – EZ-Change Interior</b> (Not available for 2 section G Heated)*	<b>2"</b>		<b>4"</b>	
Behind full height door – all models	26		13	
Behind upper half height door	12		6	
Behind lower half height door	12		6	
<b>#4 TRAYSLIDES – STANDARD (NOT AVAILABLE FOR 2 SECTION G HEATED)*</b>				
<b>Plated steel rod type for rim support of:</b> (1) 18" x 26" Pan (One pair of #4 trayslides accommodates one half section)	<b>1-1/2"</b>			
Behind full height door – all models	38			
Behind upper half height door – all models	18			
Behind lower half height door – all models	18			
<b>UNIVERSAL TRAYSLIDES – STANDARD</b>				
<b>16 ga. stainless steel angle type for bottom support of:</b> (1) 18" x 26" Pan or (2) 14" x 18" Pans or (2) 12" x 20" Pans. For heated cabinets reduce available number of trayslides by 1 (full door and the upper section of a half-door)	<b>4"</b>	<b>5"</b>	<b>6"</b>	
Behind full height door – all models	14	11	9	
Behind upper half height door – all models	6	5	4	
Behind lower half height door – all models	7	5	4	
<b>Universal Trayslides – EZ-Change Interior</b> (Not available for 2 Section G Heated)*. For heated cabinets reduce available number of trayslides by 1 (full door and the upper section of a half-door)	<b>2-1/4"</b>		<b>4-1/2"</b>	
Behind full height door – all models	22		11	
Behind upper half height door	11		5	
Behind lower half height door	11		5	
<b>Heavy-Duty Universal Trayslides – EZ-Change Interior</b> (Not available for 2 Section G Heated)*. For heated cabinets reduce available number of tray slides by 1 (full door and the upper section of a half-door)	<b>4-1/2"</b>		<b>9"</b>	
Behind full height door – all models	10		5	
Behind upper half height door	5		2	
Behind lower half height door	5		2	

### SHELVES (SOME SHELVES ARE NOT AVAILABLE FOR G HEATED)

CAPACITY	STD.	MAX.
Behind full height door mounted on standard shelf pins	3	9
Behind half height door mounted on standard shelf pins	3	8
Behind full height door mounted on optional pilasters	3	13 (4" spacing)
Behind half height door mounted on optional pilasters	3	12 (4" spacing)



Project \_\_\_\_\_  
 AIA # \_\_\_\_\_ SIS # \_\_\_\_\_  
 Item # \_\_\_\_\_ Quantity \_\_\_\_\_ C.S.I. Section 114000

## R Series

30" Wide Reach-In Refrigerator  
 32" Deep, Self-Contained



Models listed to the applicable UL, CSA and NSF standards by an approved NRTL. Consult the factory or unit data plate for additional information.

### AVAILABLE CONFIGURATIONS

#### R Series Models

RHT132WUT-FHS  
 RHT132WUT-HHS

#### Door(s)

Full Height Solid  
 Half Height Solid

### STANDARD PRODUCT FEATURES

- Stainless Steel Exterior & Interior
- Variable Speed Compressor Adapts to the Work Environment
- Traulsen's Smart Control™ with LED Display
- StayClear™ Condenser Coil
- Balanced, Self-Contained Refrigeration System Using R290
- Full or Half-Height Stainless Steel Door(s) with Lock(s)
- Anti-Condensate Door Perimeter Heater
- Self-Closing Door with Stay Open Feature
- Standard Door Hinging: 132W = Right (other hings available)
- Automatically Activated LED Lights
- Stainless Steel Breaker Caps
- Three Adjustable, Coated Wire Shelves Per Section, Supported on Shelf Pins (factory installed)
- Automatic Non-Electric Condensate Evaporator
- Magnetic Snap-In EZ-Clean™ Door Gasket
- Gasket-Protecting Raised Door Liner
- Thermostatic Expansion Valve Metering Device
- Stainless Steel One-Piece Louver Assembly
- 9' Cord & Plug Attached
- Set of (4) 6" High Adjustable Stainless Steel Legs

### ACCESSORIES & OPTIONS

- SmartConnect™ Monitoring App with Wi-Fi Connectivity
- Stainless Steel Finished Back with Rear Louvers
- Option to Relocate Electrical Box
- Accommodates EZ-Clean™ Tray Racks
- #1 Type Trayslides to Accommodate (1) 18" x 26" or (2) 14" x 18" Pans
- #4 Type Trayslides to Accommodate 18 to 19 Levels for 18" x 26" Pans
- Universal Type Trayslides to Accommodate (1) 18" x 26", (2) 14" x 18", or (2) 12" x 20" Pans
- Additional Coated Wire or Optional Stainless Steel Shelves
- Stainless Steel Banking Strip
- EZ-Open™ Foot Pedal (full-height doors only)
- Positive Action Latch (consult factory)
- Locking Hasps (padlock supplied by others)
- Optional 208-230/115/60/1, 208-230/60/1, or Export 220-240/50/1 Voltage
- Kool Klad™ Exterior Laminate Decor (consult factory)
- Set of (4) 4 1/8" or 6" High Casters in Lieu of Legs
- 6" Stainless Steel Flanged Legs
- Other Support Options: 4 1/2" High Base or 6" High Kickplate (for use with standard legs)
- Heat Shield

**\*Remote application without R-290 refrigerant is available, see form TR35837 for details.**



ENERGY STAR® Listed Commercial Refrigerator  
 For full listing visit [energystar.gov](http://energystar.gov)

**- GUARANTEED FOR LIFE CAM-LIFT HINGES**  
**- GUARANTEED FOR LIFE HORIZONTAL WORKFLOW DOOR HANDLES**

Approved by \_\_\_\_\_ Date \_\_\_\_\_ Approved by \_\_\_\_\_ Date \_\_\_\_\_



# R Series

30" Wide Reach-In Refrigerator  
32" Deep, Self-Contained

## MODEL:

RHT132WUT-HHS

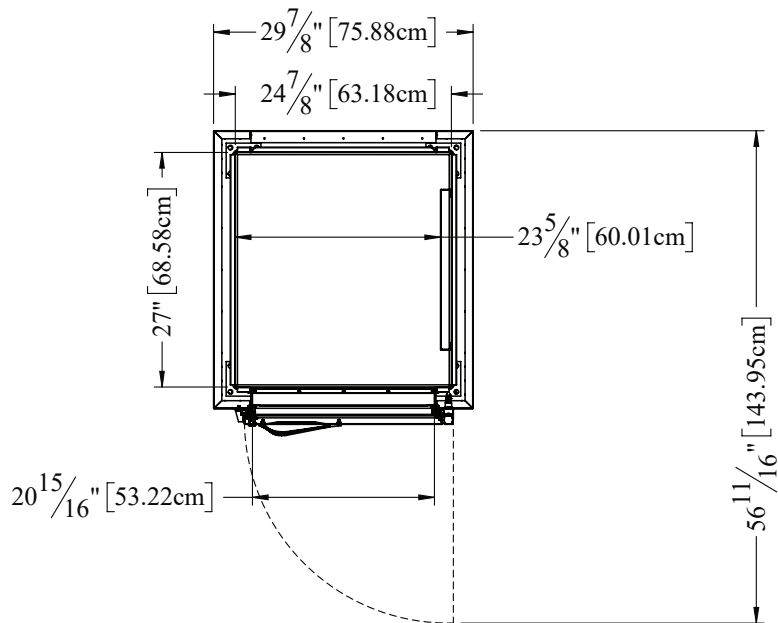

TOP VIEW

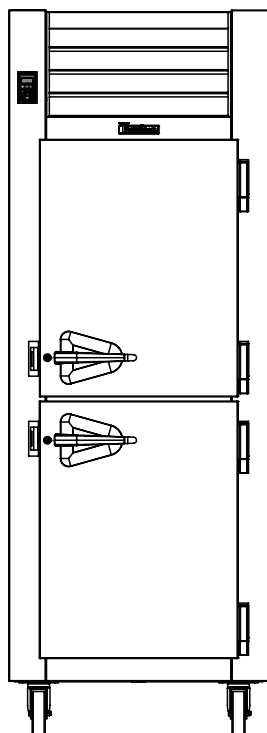

ELEVATION

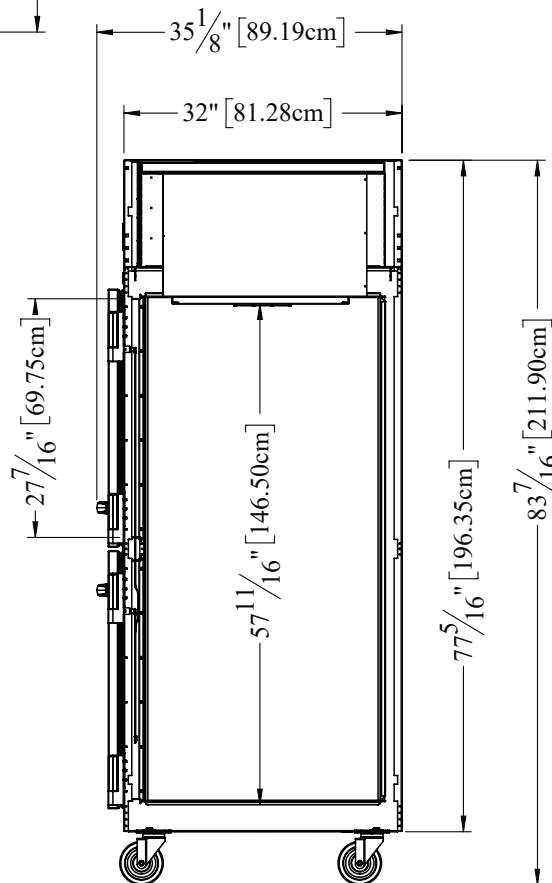

SIDE VIEW

> CAD and/or Revit Files Available

<https://traulsen.klccad.com/>



# R Series

30" Wide Reach-In Refrigerator  
32" Deep, Self-Contained

## MODEL:

RHT132WUT-FHS

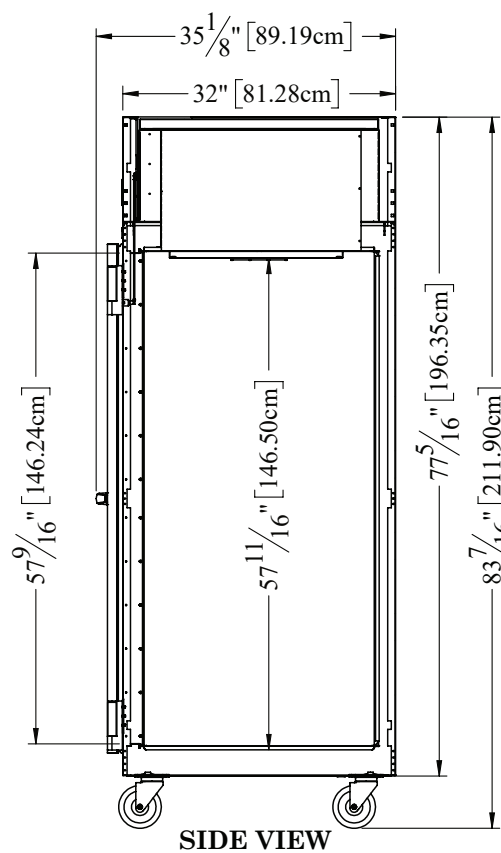
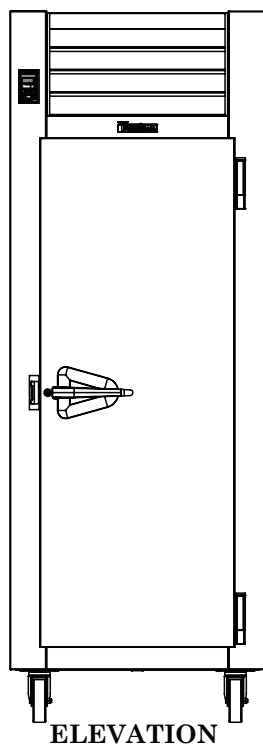
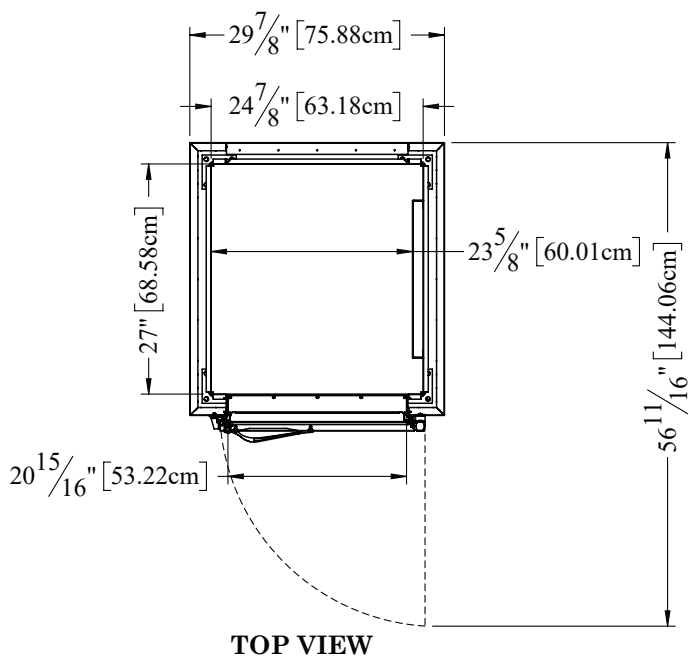

CAD and/or Revit Files Available

<https://traulsen.kclcad.com/>



## R Series

30" Wide Reach-In Refrigerator  
32" Deep, Self-Contained

### MODELS:

RHT132WUT-HHS, RHT132WUT-FHS

MODELS	R/AHT132WUT
<b>DIMENSIONAL DATA</b>	
Net capacity cu. ft.	23.43 (663.5 cu l)
Length - overall in.	29 7/8" (75.9 cm)
Depth - overall in.	35 1/8" (89.2 cm)
Depth - over body in.	32" (81.3 cm)
Depth - door open 90° in.	56 11/16" (144 cm)
Clear door width in.	20 15/16" (53.2 cm)
Clear half-door height in.	27 7/16" (69.7 cm)
Clear full-door height in.	57 9/16" (146.3 cm)
Height - overall on 6" legs <sup>2</sup>	83 7/16" (211.9 cm)
No. Standard Shelves	3
Shelf area sq. ft. <sup>3</sup>	13.46 (1.25 sq. m)
<b>ELECTRICAL DATA</b>	
Voltage   Plug	115/60/1   NEMA 5-15P
Full Load Amperes   KWH/24HR <sup>4</sup>	7.6   1.54
<b>REFRIGERATION DATA</b>	
Refrigerant	R290
Refrigerant Charge Amount oz.	4.8 (136 g)
BTU/HR   H.P. <sup>1</sup>	2875   1/2 HP
<b>SHIPPING DATA</b>	
Length - Crated in.	48" (121.9 cm)
Width - Crated in.	42" (106.7 cm)
Height - Crated in.	85" (215.9 cm)
Volume - Crated cu. ft.	99.17 (2808.2 cu l)
Weight - Crated lbs.	432 (195.9 kg)

**NOTES:** Figures in parentheses reflect metric equivalents.

1. Based on a 90°F ambient and 20°F evaporator.
2. 12" Top clearance preferred for optimum performance & service access.
3. Area of standard shelf compliment only, does not include storage area of additional shelves or available on cabinet bottom.
4. KWH/24 = Kilowatt usage per 24 hours

### EQUIPMENT SPECIFICATIONS

#### CONSTRUCTION, HARDWARE, INSULATION

The interior is made from stainless steel and the cabinet exterior front, one piece sides, louver assembly, door and door liner is constructed of heavy gauge stainless steel. The exterior cabinet top, back and bottom is constructed of heavy gauge galvanized steel. A set of four (4) adjustable 6" high stainless steel legs are included.

Door is equipped with a gasket-protecting metal door pan, removable plug cylinder locks & guaranteed for life gravity action, self-closing metal, cam-lift hinges with a stay open feature. Hinges include a concealed switch to automatically activate the interior LED lighting. Guaranteed for life, workflow door handle is mounted horizontally over recess in door which limits protrusion from door face into aiseways. Doors have seamless, polished metal corners.

Gasket profile & EZ-Clean™ material simplify cleaning & increase overall gasket life. Anti-condensate heaters are located behind the door opening. Both the cabinet & door is insulated with an average of 2" thick high density, non-CFC, foamed in place polyurethane.

#### SELF-CONTAINED REFRIGERATION SYSTEM

A top mounted, self-contained, balanced refrigeration system using environmentally friendly, low GWP R290 refrigerant is conveniently located behind the one piece louver assembly. It features a finless StayClear™ condenser, thermostatic expansion valve, air-cooled, hermetic variable speed compressor, large, high humidity evaporator coil located outside the food zone & top mounted non-electric condensate evaporator. A 9' cord & plug is provided. Standard operating temperature is 34-38°F.

#### CONTROL

Traulsen's Smart Control™ features advanced control algorithms & sophisticated diagnostic capabilities to optimize performance. Utilizing smart sensors, it adapts the operation of the refrigeration system to a variety of environments & usage patterns. The Smart Control™ also offers a complete set of visual alarms designed to alert the user to critical events such as power outages or a prolonged door opening. In the event of an alarm, a dedicated Alarm LED will illuminate, informing the user of the critical event and duration.

#### INTERIOR

Standard interior arrangements include three (3) coated wire shelves per section, mounted on shelf pins. Shelves are full-width & do not have any large gaps between them requiring the use of "bridge" or "junior" shelves. Recommended load limit per shelf should not exceed 225 lbs. Interior arrangements are installed at the factory.

#### WARRANTY

Both a six year parts and labor warranty and a seven year compressor warranty (self-contained models only) are provided standard.

When ordering please specify: Voltage, Hinging, and Options.

Equipped with one NEMA 5-15P Plug



CONTINUED PRODUCT DEVELOPMENT MAY NECESSITATE SPECIFICATION CHANGES WITHOUT NOTICE.



Project \_\_\_\_\_  
 AIA # \_\_\_\_\_ SIS # \_\_\_\_\_  
 Item # \_\_\_\_\_ Quantity \_\_\_\_\_ C.S.I. Section 114000



BLAST CHILLER ACCESSORIES

## TBC-SERIES

### Optional Condensate Evaporators for Models TBC13, TBC1H/TBC1HR & TBC2H/TBC2HR

#### Description of Purpose

Designed for use with the above models in order to provide condensate removal in lieu of a floor drain. Each includes a two-piece stainless steel upper and lower housing, which provides protection from damaging impacts, and a thermally activated evaporative pan with 9 foot cord and plug (requires provision of a separate electrical outlet) for models TBC1H, TBC1HR, TBC2H & TBC2HR. Note: On model TBC13 this can be mounted to the cabinet bottom, however for models TBC1H, TBC1HR, TBC2H & TBC2HR these are installed inside of a compartment at the cabinet bottom.

ACCESSORY	TBCACC-60018 (for all roll-in/roll-thru models only)
<b>Floor Mounted Condensate Evaporator</b>	
L x D x H - Overall in.	13 1/8 (33.3 cm) x 5 1/8 (12.9 cm) x 3 1/2 (8.9 cm)
NEMA Plug (3 wire with ground)	5-15 P (9' cord)
Voltage	115/60/1
Full Load Amps	1.5

**NOTE:** Plug requires separate electrical outlet.

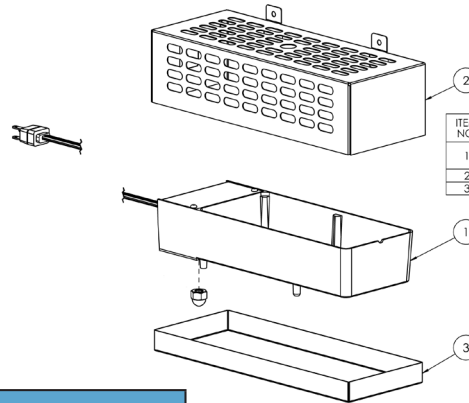

ITEM NO.	PART NUMBER	DESCRIPTION	Default/ QTY.
1	329-60072-01	117V EL. CONDENSATE EVAPORATOR W/ 120' CORD	1
2	701-60143-00	CONDENSATE EVAP. EXT. COVER	1
3	701-60144-00	COND. EVAPORATOR BTM COVER	1

ACCESSORY	TBCACC-BMCE (for TBC13 model only)
<b>Bottom Mounted Condensate Evaporator</b>	
L x D x H - Overall in.	12 1/2 (31.73 cm) x 4 7/8 (12.4 cm) x 4 1/8 (10.5 cm)
Plug (3 wire with ground)	Plugs into Receptacle on Rear of Unit (18" cord)
Voltage	220/60/1
Full Load Amps	1.4

**NOTE:** On model TBC13 the cabinet includes provisions for mounting the condensate evaporator to the cabinet bottom. This includes an outlet located on the cabinet bottom and pre-drilled mounting holes on the cabinet bottom.

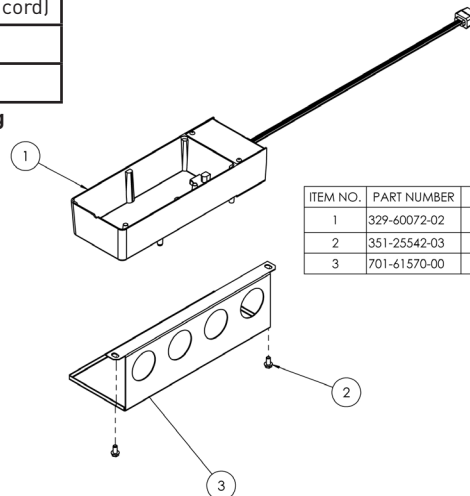

ITEM NO.	PART NUMBER	DESCRIPTION	QTY.
1	329-60072-02	220V EL. CONDENSATE EVAPORATOR W/18' CORD	1
2	351-25542-03	1/4-20 X 1/2 HWH MACHINE SCREW	2
3	701-61570-00	BMCE BRACKET TBC13	1

Approved by \_\_\_\_\_ Date \_\_\_\_\_ Approved by \_\_\_\_\_ Date \_\_\_\_\_



## TBC-SERIES

Blast Chiller, Optional Roll-In Rack  
for Models TBC1H/TBC1HR & TBC2H/TBC2HR

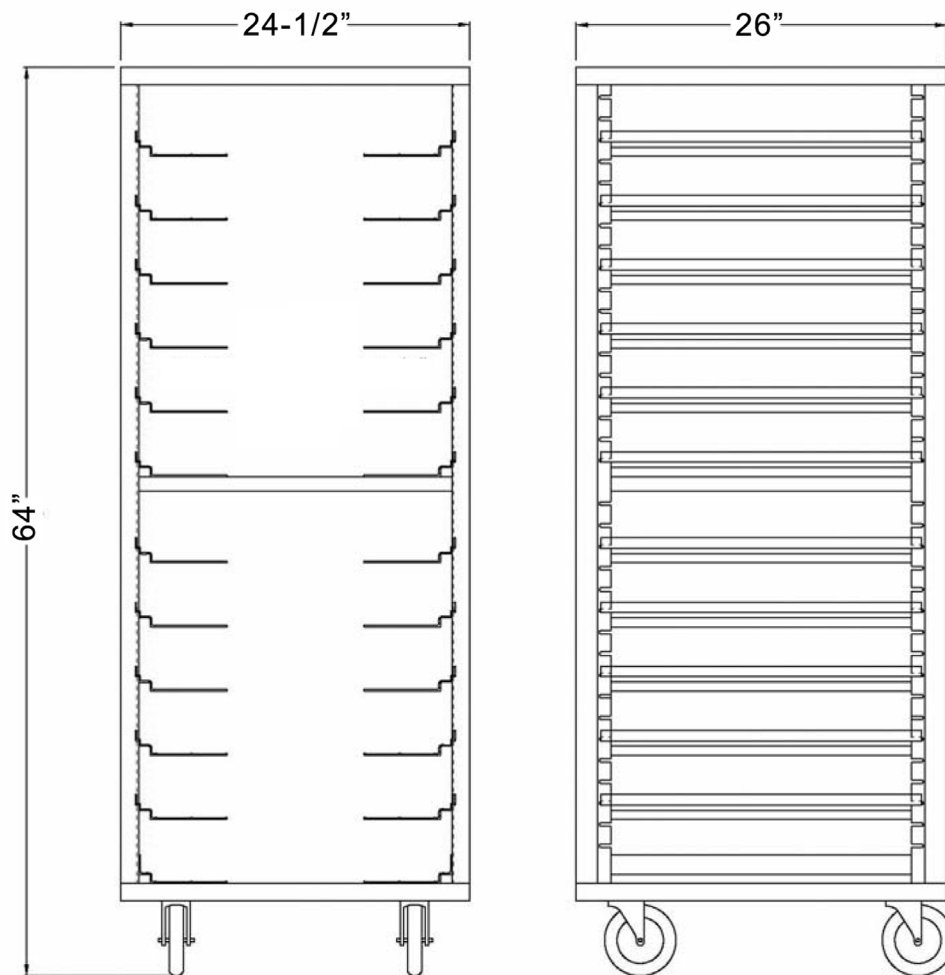

ACCESSORY	TBCACC-OTRTR (for all roll-in/roll-thru models only)
<b>OPTIONAL ROLL-IN RACK - PART# 342-60132-00</b>	
Length in.	24-1/2" (62.0 cm)
Depth in.	26" (66.0 cm)
Height in.	64" (162.5 cm)
Capacity 12"x20"x2-1/2"	24 Pans
Capacity 18"x26"	12 Sheet Pans
Capacity 14"x18"	24 Sheet Pans

#### CONSTRUCTION & HARDWARE:

Welded construction with casters. Provided with adjustable Universal Tray Slides. Roll-In Rack provides maximum chill performance, with open sides for optimum airflow.

Resolution of Candidate Nominations for the Ellis Appraisal District Board of Directors for 2026

**Presented for:**

Board Action     X                        Report/Review Only                     

**Supporting documents:**

None                                 Attached     X                Provided Later                     

**Contact Person:**

Brenda Sanford, Superintendent

**Background Information:**

Each taxing unit in Ellis County is entitled to nominate, by Resolution adopted by its governing body, one (1) candidate for each position to be filled on the Board of Directors for Ellis Appraisal District for 2026. The Resolution, Board of Directors Responsibilities, and History and information concerning the current Board of Directors are attached.

**Fiscal Implications:**

None.

**Administrative Recommendation:**

Consensus of the Board.



**ELLIS APPRAISAL DISTRICT**  
 400 Ferris Ave \* PO Box 878  
 Waxahachie, Texas 75168  
 972-937-3552 \* Toll Free 1-866-348-3552  
 ecad@elliscad.com

**Board of Directors**  
 Richard Keeler, Chairman  
 David Hurst, Vice-Chairman  
 Paula Baucum, Secretary  
 Members  
 Rusty Ballard      George Ricks  
 T.Walter Erwin      Jennifer Zarate  
                                  Dani Muckleroy  
 Richard Rozier, Ex-Oficio Member  
 Kathy Rodrigue, Chief Appraiser

August 18, 2025

Voting Taxing Units of the Ellis Appraisal District:

It is election time and the **2026 Board of Directors Taxing Unit Voting Entitlements** are enclosed. The 2026 Election is for the **two appointed directors positions** who served for a one-year term in 2025. The total possible votes to be cast is 2,000 (1,000 votes x 2 positions).

**The FIRST step for in this process is NOMINATIONS.** Each taxing unit may **nominate by resolution** adopted by its governing body (sample enclosed) one candidate for each position to be filled on the board of directors. The presiding officer of the governing body of the unit shall submit the name(s) of the unit's nominee(s) to the chief appraiser **before October 15<sup>th</sup>**.

Before October 30th, the chief appraiser will prepare a ballot, listing the candidates and shall deliver a copy of the ballot to the presiding officer of your unit. **The SECOND step in this process is for your governing body to VOTE.** The governing body shall determine its **vote by resolution** (sample enclosed) and submit it to the chief appraiser before December 15th. Your voting entitlement may be cast for one candidate or distributed as the governing body chooses. Mathematically, it should take 667 votes to secure a position on the board. The chief appraiser will count the votes, declare the five candidates who received the largest cumulative vote totals elected, and submit the results before December 31st to each governing body.

**Taxing Units with more than 5% of the total vote are listed on the following page and have additional requirements under Section 6.03(k-1).** This includes Ellis County, Ennis, Midlothian, Red Oak and Waxahachie ISDs and Cities of Midlothian and Waxahachie.

Please mark these dates for the governance of the Ellis Appraisal District:

- Before October 15**      Your governing body submits candidate(s) name(s) (with bio) to the chief appraiser
- Before October 30      I will prepare and deliver a ballot to the presiding officer of your unit
- Before December 15\***      Your governing body will vote by resolution and submit to the chief appraiser
- Before December 31      I will send the results of the election to each governing body

**Please make plans on your scheduled meetings to consider and act on these matters. Your vote is very important to the continued leadership of this board.**

I have asked the current board members Rick Keeler and Walter Erwin about their interest in serving another term. **Walter Erwin from Ennis is interested in continuing to serve on the BOD.**

So that all taxing units in the election are familiar with any new candidates, **please submit a short bio and contact information** (email and cell phone) **for any newly nominated candidate**. Please contact me if you have any questions.

Respectfully submitted,

Kathy Rodrigue, RPA

**Taxing Units with More than 5% of Total Votes in Board of Directors Election**

SECTION 3. Section 6.03, Tax Code, is amended by amending Subsection (k) and adding Subsection (k-1) to read as follows:

(k) Except as provided by Subsection (k-1), the [The] governing body of each taxing unit entitled to vote shall determine its vote by resolution and submit it to the chief appraiser before December 15. The chief appraiser shall count the votes, declare the five candidates who receive the largest cumulative vote totals elected, and submit the results before December 31 to the governing body of each taxing unit in the district and to the candidates. For purposes of determining the number of votes received by the candidates, the candidate receiving the most votes of the conservation and reclamation districts is considered to have received all of the votes cast by conservation and reclamation districts and the other candidates are considered not to have received any votes of the conservation and reclamation districts. The chief appraiser shall resolve a tie vote by any method of chance.

(k-1) This subsection applies only to an appraisal district established in a **county with a population of 120,000 or more**. The governing body of each taxing unit entitled to **cast at least five percent of the total votes** must determine its vote by resolution adopted **at the first or second open meeting of the governing body that is held after the date the chief appraiser delivers** (before October 15<sup>th</sup>) **the ballot to the presiding officer of the governing body**. The governing body must **submit its vote to the chief appraiser not later than the third day following the date the resolution is adopted**.

This **law applies** to the following taxing units that make up 84.16% of the total votes:

Ellis County	16.42%	with	328 votes
Ennis ISD	8.50%	with	170 votes
Midlothian ISD	19.32%	with	386 votes
Red Oak ISD	7.60%	with	152 votes
Waxahachie ISD	16.88%	with	337 votes
City of Midlothian	7.74%	with	155 votes
City of Waxahachie	7.70%	with	154 votes



**ELLIS APPRAISAL DISTRICT**  
400 Ferris Ave \* PO Box 878  
Waxahachie, Texas 75168  
972-937-3552 \* Toll Free 1-866-348-3552  
ecad@elliscad.com

**Board of Directors**  
Richard Keeler, Chairman  
David Hurst, Vice-Chairman  
Paula Baucum, Secretary  
Members  
Rusty Ballard      George Ricks  
T. Walter Erwin      Jennifer Zarate  
                                 Dani Muckleroy  
Richard Rozier, Ex-Oficio Member  
Kathy Rodrigue, Chief Appraiser

---

## 2025 Board of Directors History

### **APPOINTED MEMBERS**

#### **Rusty Ballard**

Member 2024-2025

#### **T. Walter Erwin**

Chairman 2024, 2022-2023, Member 2025 Part of 2021

#### **David Hurst**

Vice-Chairman 2025, Member 2024 Part of 2023

#### **Richard Keeler**

Chairman 2025, Vice-Chairman 2024, Member 2022-2023

#### **Dani Muckleroy**

Secretary 2024, 2022-2023, Member 2025 Part of 2021

### **ELECTED MEMBERS**

#### **Paula Baucum - Place 3**

Secretary 2025 Member 7/1/2024

#### **George Ricks - Place 2**

Member 2025, 7/1/2024

#### **Jennifer Zarate - Place 1**

Member 2025, 7/1/2024

#### **Richard Rozier**

Ex-Oficio Member 2025, 7/1/2024, Non  
Voting as Assessor/Collector 2021-2024

### **Efficiency:**

The Board of Directors determines the number of ARB members needed each year. Working in panels has enabled the district to minimize ARB hearings costs. This also has enabled us to complete hearings earlier and to certify the appraisal rolls on time.

### **Property Value Study and MAP:**

With the exception of 2018 and 2022, the appraisal district has been successful since 2000 with having local property value assignments to all 11 of our school districts. The district has also either met or exceeded expectations in each of the MAP reviews conducted by the Comptroller.

### **Budgeting:**

Through the use of technology, the Board has shown great stewardship in dealing with a rapidly growing county and values shifting from a market value in 2019 of \$22B to a \$54.1B roll in 2025. The budget is less than 1% of the total levy of the taxing units, which is extremely rare for a district of our size.

### **Technology:**

This Board looks forward each year to sharing with each of you the latest technological investment in aerial and oblique photography, Eagleview (fka Pictometry) and Changefinder. The entities of EAD receive the imagery, tools and internet access at no charge. We also offer a robust website for the research purposes.

We encourage you to take a look at EAD's stewardship in the 2024 Ellis Appraisal District Annual Report on the District website at: <https://www.elliscad.com/reports> then go to Appraisal Reports to see the work your District does for you and the property owners we all serve.

## **ELLIS APPRAISAL DISTRICT 2026 BOARD OF DIRECTORS**

### **Eligibility:**

Person must have resided in the appraisal district for at least two years immediately preceding the date the individual takes office. Person may not be an employee of a taxing unit served by the appraisal district, but may be an elected official or a member of the governing body. A person may not be appointed if related within the second degree of consanguinity or affinity to either an appraiser who appraiser property for use in the appraisal district's appraisal review board proceedings or a tax representative who represents taxpayers for compensation before the appraisal district's appraisal review board. A person may not have delinquent taxes for more than 60 days after the date the person knew or should have known of the delinquency.

### **Term:**

For 2026, two (2) appointed members will begin serving a four-year term 2026-2029 and in 2028, three (3) appointed members will be serving a four-year term 2028-2031.

### **Meetings:**

Meetings are required quarterly but are typically held 6-10 times a year typically on the second Thursday of the month at 8:30am or at the call of the chair.

### **Compensation:**

Directors may not receive a salary, per diem, or other compensation. They are reimbursed for reasonable and necessary expenses incurred in the performance of a director's duties if included in the appraisal district budget.

### **Training:**

Effective 9/1/2025, BOD members are required to attend an 8-hour training session prior to service covering:

The role and functions of the chief appraiser, board of directors, appraisal review board and taxpayer liaison officer; the comptroller regarding the property tax system; the importance of maintaining the independence of an appraisal office from political pressure; the importance of prompt, courteous, and fair treatment of the public; the finance and budgeting requirements for an appraisal district, including appropriate controls to ensure that expenditures are proper; the procurement and contracting requirements for an appraisal district, including appropriate controls to ensure there are no conflicts of interest; the requirements of Chapters 551, 552, 2001 of the Government Code; other laws relating to public officials, including conflicts of interest laws; and the standards of ethics imposed by the Uniform Standards of Professional Appraisal Practice; and the professions regulated under Chapter 1151, Occupations Code.

### **General Statement of Functions:**

The board of directors has the following primary responsibilities:

- Establish the appraisal district's office;
- Adopt the appraisal district's annual operating budget and bi-annual reappraisal plan;
- Contract for necessary services;
- Hire a chief appraiser;
- Appoint a taxpayer liaison officer; and
- Make general policy on the appraisal district's operation.

**ELLIS APPRAISAL DISTRICT  
2026 BOARD OF DIRECTORS  
TAXING UNIT VOTING ENTITLEMENT**

1,000 VOTES PER BOARD OF DIRECTOR MEMBER TO BE APPOINTED:						2	5
TAXING UNITS	2024 CERT FRZ ADJ TAXABLE VALUES (as of 7/24/2025)	2024 TAX RATES	TAX LEVY ON ACCTS WITH CLNGS AT CERT	2024 TOTAL LEVY	% OF TOTAL LEVY	2026 VOTES 2,000	2025 VOTES 5,000
ELLIS COUNTY	30,533,096,784	0.255357	9,756,962.38	87,725,362.33			
ELIS COUNTY & LATERAL ROAD	30,430,313,951	0.018635	804,865.08	6,475,554.08	16.42%	328	750
AVALON ISD	79,330,703	0.821530	18,364.24	670,089.76	0.12%	2	7
ENNIS ISD	3,927,407,365	1.215200	1,031,737.14	48,757,591.44	8.50%	170	473
FERRIS ISD	923,900,239	1.140800	316,049.38	10,855,903.31	1.89%	38	90
FROST ISD	8,094,674	0.999200	611.42	81,493.40	0.01%	1	1
ITALY ISD	247,790,646	1.073700	63,671.62	2,724,199.79	0.47%	9	27
MIDLOTHIAN ISD	9,813,793,205	1.076900	5,200,821.20	110,885,560.22	19.32%	386	1,019
MILFORD ISD	137,045,031	1.098160	15,434.62	1,520,408.33	0.26%	5	12
PALMER ISD	535,903,976	1.050200	348,533.01	5,976,596.57	1.04%	21	60
RED OAK ISD	3,730,551,160	1.103300	2,423,898.97	43,583,069.92	7.60%	152	408
WAXAHACHIE ISD	7,895,333,961	1.168100	4,620,501.20	96,845,897.20	16.88%	337	910
MAYPEARL ISD	707,801,373	0.976600	579,879.78	7,492,267.99	1.31%	26	72
CITY OF ALMA	70,648,620	0.250000	0.00	176,621.55	0.03%	1	1
CITY OF BARDWELL	35,359,114	0.172755	0.00	61,084.64	0.01%	1	1
CITY OF CEDAR HILL	212,056,674	0.636455	0.00	1,349,645.30	0.24%	5	10
CITY OF ENNIS	3,108,902,910	0.664000	1,430,456.12	22,073,571.44	3.85%	77	186
CITY OF FERRIS	375,335,063	0.534800	167,074.68	2,174,366.60	0.38%	8	20
CITY OF GARRETT	52,682,094	0.269453	0.00	141,953.48	0.02%	1	1
CITY OF GLENN HEIGHTS	822,961,527	0.565015	0.00	4,649,856.07	0.81%	16	37
CITY OF GRAND PRAIRIE	350,888,609	0.660000	30,174.39	2,346,039.21	0.41%	8	9
CITY OF ITALY	169,415,046	0.435213	92,813.68	830,129.98	0.14%	3	8
CITY OF MANSFIELD	191,104,455	0.645000	37,464.32	1,270,088.05	0.22%	4	10
CITY OF MAYPEARL	75,159,394	0.500000	46,421.43	422,218.40	0.07%	1	4
CITY OF MIDLOTHIAN	6,479,526,338	0.650000	2,306,873.00	44,423,794.20	7.74%	155	360
CITY OF MILFORD	53,836,136	0.252260	21,000.76	156,807.80	0.03%	1	1
CITY OF OAK LEAF	241,360,944	0.301542	0.00	727,804.62	0.13%	2	6
CITY OF OVILLA	488,287,061	0.626213	777,289.64	3,835,006.69	0.67%	13	29
CITY OF PALMER	238,387,717	0.666947	0.00	1,589,919.73	0.28%	5	13
CITY OF PECAN HILL	73,768,507	0.226135	0.00	166,816.41	0.03%	1	2
CITY OF RED OAK	2,444,314,394	0.696886	1,138,743.21	18,172,828.02	3.17%	63	118
CITY OF VENUS	190,056,134	0.738059	33,541.03	1,436,267.43	0.25%	5	9
CITY OF WAXAHACHIE	6,690,179,402	0.610000	3,389,657.79	44,199,752.14	7.70%	154	346
<b>TOTAL</b>				<b>573,798,566.12</b>	<b>100.00%</b>	<b>2,000</b>	<b>5,000</b>

I, KATHY A. RODRIGUE, CHIEF APPRAISER FOR THE ELLIS APPRAISAL DISTRICT,  
DO HEREBY CERTIFY THAT THE ABOVE VOTING ENTITLEMENTS  
ARE TRUE AND ACCURATE TO THE BEST OF MY KNOWLEDGE.

  
KATHY RODRIGUE, RPA - CHIEF APPRAISER

SUBSCRIBED AND SWORN BEFORE ME THIS 18TH DAY OF AUGUST, 2025.

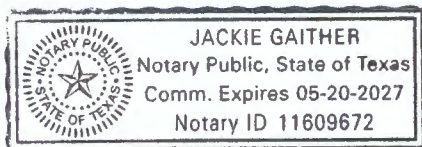

  
JACKIE GAITHER, NOTARY

TAXING UNIT: \_\_\_\_\_

Resolution No. \_\_\_\_\_

RESOLUTION OF **CANDIDATE NOMINATIONS** FOR THE ELLIS APPRAISAL DISTRICT BOARD OF DIRECTORS FOR THE YEAR 2026\*

WHEREAS, Section 6.03 (g) of the Texas Property Tax Code, requires that each taxing unit entitled to vote may nominate by Resolution one candidate for each position to be filled on the Board of Directors and submit the nomination(s) to the Chief Appraiser of the Ellis Appraisal District before October 15, 2025.

THEREFORE, the \_\_\_\_\_ submits the following nomination(s) with contact information for Board of Directors of the Ellis Appraisal District for 2026:

Name	E-mail	Cell	Bio Included

ACTION TAKEN this \_\_\_\_\_ day of \_\_\_\_\_, 2025, in \_\_\_\_\_ Session of the governing body of the above mentioned taxing unit; as authorized under Section 6.03 of the Texas Property Tax Code, for the purpose of nominating candidates to the Board of Directors of the Ellis Appraisal District.

\_\_\_\_\_  
Presiding Officer

ATTEST: \_\_\_\_\_

\*This election is for 2026, to appoint two directors who will begin serving a four-year term January 1, 2026.

TAXING UNIT: \_\_\_\_\_

Resolution No. \_\_\_\_\_

RESOLUTION OF **VOTES CAST** TO ELECT DIRECTORS FOR THE ELLIS APPRAISAL DISTRICT FOR THE YEARS 2025\*

WHEREAS, Section 6.03 (k) of the Texas Property Tax Code, requires that each taxing unit entitled to vote cast their vote by Resolution and submit results of that vote to the Chief Appraiser of the Ellis Appraisal District before December 15, 2025.

THEREFORE, the \_\_\_\_\_ submits the attached Official Ballot, as issued by the Chief Appraiser, stating the votes cast for candidates in the 2026 Board of Directors' Election for the Ellis Appraisal District.

ACTION TAKEN this \_\_\_\_\_ day of \_\_\_\_\_, 2025, in \_\_\_\_\_ Session of the governing body of the above mentioned taxing unit; as authorized under Section 6.03 of the Texas Property Tax Code, for the purpose of casting votes to elect the Board of Directors of the Ellis Appraisal District.

\_\_\_\_\_  
Presiding Officer

ATTEST:

\_\_\_\_\_

\*This election is for 2026, to appoint two directors who will begin serving a four-year term January 1, 2026.

School Library Advisory Council (SLAC)

**Presented for:**

Board Action   X   Report/Review Only \_\_\_\_\_

**Supporting documents:**

None \_\_\_\_\_ Attached   X   Provided Later \_\_\_\_\_

**Contact Person:**

Laura Kelly, Director of Instructional Technology

**Background Information:**

Per recent legislation and district policy, the SLAC is established to support transparency and community involvement in the selection and maintenance of library materials. Each board member is responsible for appointing at least one member to the council, with equal representation among trustees. Appointees must be district parents and not employees. Names of potential appointees have been collected and shared with board members for consideration. Listed below are the school board members' appointments to the School Library Advisory Council.

**2025-2026 SLAC Committee Members:**

- Trish Murphy (Parent-HS/ROMS)
- Jackie Arias (Parent-HS/EE)
- Noemi Cruz (Parent-HS)
- Nicole Tye (Parent-JSMS)
- Katrina Bushdiecker (Parent-DTS)
- Hanson Inyang (Parent-ROE)
- Allissa Gonsoulin (Parent)-DTS

**Fiscal Implications:**

None.

**Administrative Recommendation:**

Administrations recommends that the Red Oak ISD Board of Trustees formally appoint the above members to the School Library Advisory Council (SLAC) in accordance with Board Policy EFB(LOCAL), adopted July 29, 2025.

---

**Note:** For information related to the selection of instructional materials, see EFA.

---

The purpose of this policy is to ensure that the District provides a wide range of library materials for students and faculty that support student achievement and present varying levels of difficulty, diversity of appeal, and a variety of points of view. This policy also provides standards for collection development and the selection and evaluation of library materials.

**School Library  
Advisory Council**

The Board has established a school library advisory council (SLAC). At the first meeting of the SLAC, the members shall select a chair.

The SLAC shall meet at least two times each year but may hold additional meetings in order to consider recommendations from District staff and fulfill its statutory duties.

**Collection  
Development Policy**

In this policy, "library materials" is defined by law and may include printed and electronic library acquisitions, including online catalogs, and other ancillary or supplementary materials maintained in a campus library. [See EFB(LEGAL)]

The library collection development standards shall apply to all library materials available for use or display, including material contained in school libraries, classroom libraries, online catalogs, library mobile applications used in the District, and any other library catalog a student may access.

In developing library collections, the District shall consider the age groups, grade levels, and access to library material by all students on a campus.

**Responsibility**

The District shall ensure the members of the SLAC, librarians, professional library staff, and other designated professional staff are trained or receive information on the proper collection development standards.

The Superintendent shall develop administrative procedures to ensure that library collections comply with applicable law, library standards, and the District's collection development purpose and goals.

**Collection  
Development Goals**

In addition to the requirements in state law and rules, the District's library collections shall:

1. Present multiple viewpoints related to controversial issues [see EMB regarding instruction about controversial issues].
2. Provide a wide range of background information that will enable students to make intelligent decisions in their daily lives.

INSTRUCTIONAL RESOURCES  
LIBRARY MATERIALS

EFB  
(LOCAL)

3. Include accurate and authentic factual content from authoritative sources.
4. Have a high degree of potential user appeal and interest.
5. Offer a global perspective that promotes equity of access, including print and nonprint materials such as electronic and multimedia, to meet the needs of individual learners.
6. Represent diverse viewpoints and cultural groups of the state and their contributions to the state, the nation, and the world, to ensure the collection embodies the background of all students.

Recommendation  
and Procurement of  
Materials

Library materials shall be recommended and procured in accordance with guidelines adopted by the Texas State Library and Archives Commission and the District standards and priorities expressed in this policy.

Librarians and other professional staff shall assist the SLAC in developing the list of library material recommendations to be presented to the Board. The librarians and other professional staff shall ensure that the materials:

1. Enrich and support the TEKS and the state and local curriculum, taking into consideration students' varied interests, maturity levels, abilities, and learning styles.
2. Foster growth in factual knowledge, literary appreciation, aesthetic values, and societal standards.
3. Encourage the enjoyment of reading, foster high-level thinking skills, support personal learning, and encourage discussion based on rational analysis.
4. Represent ethnic, religious, and cultural groups of the state and their contributions to the state, the nation, and the world.

The Superintendent shall ensure that administrative procedures regarding the development of recommendations of library materials consider at least two of the following factors:

1. Recommendations from students, parents or guardians, teachers, and District residents.
2. Consultation with District teachers and library staff.
3. Consultation with library staff from other districts.
4. Extensive review of the library material.
5. Context of the library material, including overall fit within the existing collection and support of District curriculum.

INSTRUCTIONAL RESOURCES  
LIBRARY MATERIALS

EFB  
(LOCAL)

6. Reviews of the library material from sources such as professional journals in library science, recognized professional education or content journals with book reviews, national and state award recognition lists, library science field experts, and highly acclaimed author and literacy expert recommendations.
7. Coverage of topics, authors, series, or genres that fill gaps in the school library collection.

The SLAC shall recommend to the Board a list of library materials for procurement.

The Board shall consider the SLAC's recommended list of library materials that have been donated or proposed by the SLAC for procurement. Each Board member may propose changes before the Board takes action on the list of donated or proposed library materials.

The Board shall either approve or reject the library materials that have been donated or proposed for procurement.

Donated and  
Proposed  
Procurement List

At least 30 days prior to the Board's vote to accept donated library materials or approve procurement of library materials, the Superintendent shall make accessible to the public the list of library materials in accordance with law.

Access Plan

The District shall allow efficient parental access to the District's library and any available online catalogs.

Online catalogs shall be publicly available. The District shall publish information about library material titles, including how and where material can be accessed.

Each campus shall communicate the following to parents and guardians:

- Access to policies relating to school libraries and library materials;
- Consistent access to library materials and resources; and
- Opportunities for students, parents and guardians, educators, and community members to provide feedback on library materials and services.

Parental  
Involvement

Parents and guardians are the primary decision-makers regarding their child's access to library material. In general, a student is afforded the opportunity to self-select library materials as part of literacy development and the library program. District staff may assist a student in selecting library material; however, the ultimate determination of appropriateness remains with the student and parent or

guardian. Parents and guardians are encouraged to communicate with the campus librarian and their child's teacher about special considerations regarding library materials self-selected by their child.

In accordance with state law and administrative procedures, parents or guardians may submit to the principal or a staff member designated by the principal a list of library materials that the parent's or guardian's child shall not be allowed to check out or access for use outside of the school library. The Superintendent shall develop procedures that permit a parent or guardian to submit the request in at least one of the methods permitted by law.

The parent or guardian may select alternative library materials for their child. [For information on parental rights regarding instructional materials and other instructional resources, see EFA(LEGAL).]

The District shall focus on maximizing transparency with parents while meeting student needs and providing enrichment opportunities with library materials. Parental involvement in library acquisition, maintenance, and campus activities is encouraged.

*Access  
Procedures*

School Library

A parent or guardian who wishes to access a school's library shall first submit a request to the principal. The principal or a staff member designated by the principal shall work with the parent or guardian to determine a time to access the library that will not interfere with the delivery of instruction or disrupt student use of library services.

Library Catalog

A parent or guardian who wishes to access the catalog of library materials for any school in the District shall submit a written request to the school's principal. The principal or a staff member designated by the principal shall respond to the request in accordance with administrative procedures.

Protection from  
Inappropriate  
Material

In accordance with law and guidance from the Texas State Library and Archives Commission, library materials shall not include "harmful material"; any library material that is pervasively vulgar or educationally unsuitable; any library material containing indecent or profane content; any library material that refers a person to a website, including by use of a link or QR code, containing content legally prohibited under law; or any other material legally prohibited from inclusion in a public school library. [See EFB(LEGAL)]

Obscene material is not protected by the First Amendment to the United States Constitution.

	<p>Library materials shall comply with the Children’s Internet Protection Act (CIPA), including technology protection measures. [See CQ]</p>
<b>Challenge of Library Material</b>	<p>A District employee, a parent or guardian of a District student, or a District resident may challenge library material maintained in the District’s library program.</p> <p>The SLAC shall recommend to the Board for adoption the procedures for challenging library materials.</p>
Guiding Principles	<p>The following principles shall guide the review of a challenge of library material:</p> <ol style="list-style-type: none"><li>1. An individual may challenge library material used in the District’s library program, despite the fact that the professional staff, SLAC, and the Board followed the proper procedure and adhered to the objectives and criteria for recommending and procuring library materials set out in this policy.</li><li>2. Access to challenged material shall be restricted during the challenge process.</li></ol> <p>In addition to compliance with state law and this policy, a criterion for the final decision on challenged library materials is the appropriateness of the material for its intended use. No challenged library material shall be removed solely because of the ideas expressed in the library material or the personal background of the library material’s author or the personal background of the characters in the material.</p>
Formal Challenge	<p>The District shall make the Texas Education Agency form to challenge library material available on the District’s website.</p> <p>If a District employee, a parent or guardian of a District student, or a District resident wishes to challenge library material, they shall follow the procedures to complete and submit the challenge form.</p> <p>In addition to copies of the completed form being provided to the members of the SLAC in accordance with law, copies shall also be provided to the Board, the Superintendent, the school librarian, and any other staff designated in administrative procedures.</p>
SLAC Recommendation	<p>The SLAC shall consider the challenge in accordance with Board-adopted procedures and in accordance with law and shall make a recommendation to the Board.</p> <p>Any meeting of the SLAC or a review committee, if any, must comply with the meeting requirements under Education Code 33.025(g) and (h), including required notices, meeting minutes, audio or</p>

INSTRUCTIONAL RESOURCES  
LIBRARY MATERIALS

EFB  
(LOCAL)

video recordings, and submission of minutes and audio or video recordings of the meeting to the District.

The Superintendent, the school librarian, the individual submitting the challenge, and any other appropriate staff shall receive a copy of the SLAC's recommendation.

**Appeal**

An individual who submitted a challenge may appeal the decision of the SLAC to the Board in accordance with the challenge procedures.

When considering the appeal, the Board shall consider the factors in Education Code 33.027(f). The Board shall consider appeals in accordance with timelines set out in law.

**Frequency of Review**

After a library material has been challenged and the Board determines not to remove the library material from a school library catalog, it may not be challenged again before the second anniversary of the Board's final decision not to remove the material.

**Removal of Library Materials**

If a challenge to a library material results in the removal of the library material from the school library catalog, each teacher assigned as the classroom teacher at the grade level for which the library material was removed shall be notified and instructed to remove any copy of the library material from the teacher's classroom library, if applicable.

**Maintenance of Library Materials**

In accordance with state guidelines and District administrative procedures, collections shall be evaluated and updated regularly based on the collections' age, relevance, diversity, and variety. The Superintendent shall ensure administrative procedures are established for regular maintenance of the library collection on each campus. Standard maintenance procedures for any library collection include repair, replacement, and removal of materials as necessary. Regular maintenance shall also include scheduled inventories of the collection. Disposal of any District-owned library materials shall be in accordance with District policy and procedures. [See C]

**Gifts and Donations**

The Board shall accept gifts and donations of library materials with the understanding that the use and disposition of the materials and monies will be in accordance with District policy and the selection criteria noted above. [See CDC]

**Policy Review**

This policy shall be reviewed at least every three years and revised as necessary.