



# NORTHERN VALLEY SCHOOLS USD 212



ALMENA

MONTHLY MEETING  
MONDAY, JANUARY 10, 2022, AT 6:30 PM  
ALMENA HIGH SCHOOL  
512 W BRYANT STREET  
ALMENA, KS 67622  
PHONE (785) 669-2445

LONG ISLAND

A Monthly Meeting of the Board of Trustees of Northern Valley Schools was held Monday, January 10, 2022, beginning at 6:30 PM in the Almena High School  
512 W Bryant Street  
Almena, KS 67622.

I. Call to Order	
II. Elections	
A. School Board Leadership Elections	
III. Adoption of Agenda	
IV. Approval of Minutes	2
V. Approval of Bills	7
VI. Hearing of Visitors	
A. Jessie Thalheim	
VII. Old Business	
A. BOE / Administration Evaluation	34
B. Transportation Update	42
C. Snow Removal / Lawn Care	45
D. Negotiations Training	
VIII. Personnel	
A. School Board Recognition Month	46
B. Supplemental Position	48
C. Classified Position	
D. Certified Staffing	
IX. New Business	
A. Insurance Claim	49
B. Board Walk Through	60
C. WKLL Scholarship Testing	
D. Fire Alarm Monitoring	61
E. Federal Mileage Rate	64
F. March Board Meeting	
X. Administrative Reports	
A. Superintendent / 9-12 Principal Report	65
B. K-8 Principal Report	
XI. Reports of Board Members	
XII. Adjournment	



# NORTHERN VALLEY SCHOOLS USD 212

DISTRICT OFFICE  
512 WEST BRYANT PO BOX 217  
ALMENA KS 67622



ALMENA

PHONE (785) 669-2445

LONG ISLAND

A Monthly Meeting of the Board of Trustees of Northern Valley Schools was held Monday, December 13, 2021, beginning at 6:30 PM in the Long Island Middle School, 627 Washington, Long Island, KS 67647.

Shanna Hammond:	Present
Christopher Rogers:	Present
Laquita Smith:	Present
Hilary Van Patten:	Present
Rich Wenzl:	Absent
Steven Whitney:	Absent

## I. Call to Order

The meeting was called to order by Mrs. VanPatten at 0630. There were only three members present to begin with, so the agenda order was altered. Here is the order of events: Hearing of Visitors, Transportation Update, KESA Update, Upcoming Training Opportunities, & Insurance Update. At that time (6:55 PM), a fourth board member arrived and then we went back to the top of the agenda and attended those that required action in the order presented.

## II. Adoption of Agenda

I recommend the board approve the agenda as presented. This motion, made by Shanna Hammond and seconded by Christopher Rogers, Carried.

Shanna Hammond:	Yea
Christopher Rogers:	Yea
Laquita Smith:	Yea
Hilary Van Patten:	Yea
Rich Wenzl:	Absent
Steven Whitney:	Absent

Yea: 4, Nay: 0, Absent: 2

## III. Approval of Minutes

I recommend the board approve the minutes of the November board meeting as presented. This motion, made by Christopher Rogers and seconded by Laquita Smith, Carried.

Shanna Hammond:	Yea
Christopher Rogers:	Yea
Laquita Smith:	Yea
Hilary Van Patten:	Yea
Rich Wenzl:	Absent
Steven Whitney:	Absent

Yea: 4, Nay: 0, Absent: 2

## IV. Approval of Bills

I recommend the board approve the bills as presented. This motion, made by Shanna Hammond and seconded by Laquita Smith, Carried.

Shanna	Yea
--------	-----



# NORTHERN VALLEY SCHOOLS USD 212

DISTRICT OFFICE  
512 WEST BRYANT PO BOX 217  
ALMENA KS 67622



ALMENA

PHONE (785) 669-2445

LONG ISLAND

Hammond:

Christopher      Yea  
Rogers:

Laquita Smith:    Yea

Hilary Van            Yea  
Patten:

Rich Wenzl:        Absent

Steven Whitney:   Absent

Yea: 4, Nay: 0, Absent: 2

## V. Hearing of Visitors

### A. Kirsten Baird

Mrs. Baird visited about the annual Angel Tree project her class participates in. First National Bank and Trust has a tree set up with ornaments identifying needs and requests for gifts. The fifth graders participate in fund-raising (popcorn and bake sale) events that allow them to contribute to this cause each year.

### B. Sarah Rudd

Mrs. Rudd shared the heat press she purchased for the school and then shared some of the products that could be made with the new device. This is a way to help school organizations have a better profit margin for fundraising events, offer faster turn around on product orders, and allow students to learn valuable marketing skills. She also presented the board with t-shirts, made with the press, as a thank you for their support and work they do for the school.

## VI. Old Business

### A. Work Release Requests

Mr. Tharman shared that the three applicants were all in good standing with attendance and grades. After some discussion, it was agreed to add wording to the application that would require students to make their application more professional and to represent the skills they have learned. I recommend the board approve the work release requests for the spring semester as presented. This motion, made by Shanna Hammond and seconded by Laquita Smith, Carried.

Shanna

Hammond:    Yea

Christopher      Yea  
Rogers:

Laquita         Yea  
Smith:

Hilary Van        Yea  
Patten:

Rich              Absent  
Wenzl:

Steven            Absent  
Whitney:

Yea: 4, Nay: 0, Absent: 2

### B. Transportation Update

Mr. Gebhard went over some of the recent transportation repairs.

## VII. Personnel

### A. Staffing

I recommend the board go into executive session to discuss nonelected personnel matters, to protect the privacy interests of the individual(s) to be discussed; retaining Mr. Tharman and Mr. Gebhard and



# NORTHERN VALLEY SCHOOLS USD 212

DISTRICT OFFICE  
512 WEST BRYANT PO BOX 217  
ALMENA KS 67622



ALMENA

PHONE (785) 669-2445

LONG ISLAND

returning to open session in the board room at 7:13 PM. This motion, made by Shanna Hammond and seconded by Christopher Rogers, Carried.

Shanna  
Hammond: Yea

Christopher  
Rogers: Yea

Laquita  
Smith: Yea

Hilary Van  
Patten: Yea

Rich  
Wenzl: Absent

Steven  
Whitney: Absent

Yea: 4, Nay: 0, Absent: 2

Meeting returned to open session at 7:13 PM. I recommend the board go into executive session to discuss nonelected personnel matters, to protect the privacy interests of the individual(s) to be discussed; retaining Mr. Tharman and Mr. Gebhard and returning to open session in the board room at 7:18 PM. This motion, made by Shanna Hammond and seconded by Christopher Rogers, Carried.

Shanna  
Hammond: Yea

Christopher  
Rogers: Yea

Laquita  
Smith: Yea

Hilary Van  
Patten: Yea

Rich  
Wenzl: Absent

Steven  
Whitney: Absent

Yea: 4, Nay: 0, Absent: 2

Meeting returned to open session at 7:18 PM. No action taken.

## B. BOE / Administration Evaluations

Kinze had organized the 25 responses from staff members into Excel and Word documents. Board members took time to review the information. It was requested to have an average score for each question presented at the January meeting.

## C. Leave Request

I recommend the board approve the leave request as presented. This motion, made by Christopher Rogers and seconded by Laquita Smith, Carried.

Shanna  
Hammond: Yea

Christopher  
Rogers: Yea

Laquita  
Smith: Yea



# NORTHERN VALLEY SCHOOLS USD 212

DISTRICT OFFICE  
512 WEST BRYANT PO BOX 217  
ALMENA KS 67622



ALMENA

PHONE (785) 669-2445

LONG ISLAND

Hilary Van Patten: Yea

Rich Wenzl: Absent

Steven Whitney: Absent

Yea: 4, Nay: 0, Absent: 2

## VIII. New Business

### A. December KASB Policy Updates

Twice a year KASB reviews the policies and makes recommendations for updates. Mr. Tharman went over the proposed changes. I recommend the board approve the December 2021 KASB Policy Updates as presented. This motion, made by Laquita Smith and seconded by Shanna Hammond, Carried.

Shanna Hammond: Yea

Christopher Rogers: Yea

Laquita Smith: Yea

Hilary Van Patten: Yea

Rich Wenzl: Absent

Steven Whitney: Absent

Yea: 4, Nay: 0, Absent: 2

### B. KESA Update

Mr. Tharman did a recap on the past five years of the KESA (Kansas Education Systems Accreditation) process. On February 22nd, the district will have the OVT (Outside Validation Team) visit. Once this is complete, the information will be presented to the ARC (Accreditation Review Council).

### C. Upcoming Board Training Opportunities

Negotiation training is an annual requirement for those on the negotiating team. The training offered by KASB on Thursday, February 10th (1 - 3 PM) was selected as the preferred day.

### D. Insurance Update

Mr. Tharman shared two upcoming health insurance meetings: American Fidelity (Gravie) on December 14th @ 1:00 PM. and .

Freedom Claims Management on December 20th @ 9:00 AM.

### E. Preschool Funding

At the last Council of Superintendents meeting, Mr. Tharman learned that the state is allowing 3-year old at-risk students to qualify for state funding (0.5 student). This is a significant amount of possible revenue. The one element that keeps Northern Valley from qualifying for this .... is the number of hours those students are enrolled in. Students need to have 456 hours per school year in order to qualify for the funding. Currently, our three-year olds are here 324 hours per school year. Discussion followed. It was agreed that we need to consider some changes to capitalize on this opportunity. Mr. Gebhard will share this information at the next Kindergarten Readiness meeting.

## IX. Administrative Reports

### A. Superintendent / 9-12 Principal Report

Five freshmen, three sophomores, three juniors, and one senior volunteered to represent NV in the annual WKLL Scholarship Testing. This is an academic competition with the other league schools. Mr. Tharman



# NORTHERN VALLEY SCHOOLS USD 212

DISTRICT OFFICE  
512 WEST BRYANT PO BOX 217  
ALMENA KS 67622



ALMENA

PHONE (785) 669-2445

LONG ISLAND

asked the board to look ahead for scheduling Building Walk-Throughs. It was agreed that January 25th would be the preferred date.

Superintendent Evaluation will be sent out to each board member later this week. Christmas Break starts Dec. 23rd and teachers return for a workday on Jan. 3rd. Students return on Jan. 4th. We have a new student that will be starting after break as well. The KSDE Audit will be the week of January 10th. Amber and Kinze are collecting the requested information.

The KCTC (Kansas Communities That Care) survey will be done on January 12th.

HS Youth Survey results were shared with the board. Next month the board will elect officers and set meeting dates and times for the next year.

#### B. K-8 Principal Report

Mr. Gebhard shared about JH basketball / Christmas concert on Monday, Dec. 20th in the HS Auditorium / Bake sale during the BB game on Thursday, Dec. 16th / Watch D.O.G.S (Dads Of Great Students) will be starting up again in the spring semester. / AR parties will be next week. The Spelling Bee is set for January 25th.

#### X. Reports of Board Members

#### XI. Adjournment

I move to adjourn. This motion, made by Shanna Hammond and seconded by Laquita Smith, Carried.

Shanna	Yea
Hammond:	
Christopher	Yea
Rogers:	
Laquita Smith:	Yea
Hilary Van	Yea
Patten:	
Rich Wenzl:	Absent
Steven Whitney:	Absent

Yea: 4, Nay: 0, Absent: 2

# USD 212

## Check Listing Report

Accounting Cycle: FY21-22; Begin Date: 12/14/2021; End Date: 01/07/2022; Bank: [All]; Sort By Element: FUND; Account Expression: [All]; Created On: 1/7/202

Voucher Number	Bank Name	Account Number	Check Number
Terry Logemann Retention Pay	First National Bank & Trust	003174	62981
Vendor	PO Number	Invoice #	Account Code
Terry Logemann	22-1424	010722	07-2600-125-00-00
<b>Sub Total</b>			
Voucher Number	Bank Name	Account Number	Check Number
Bills for January Board Meeting	First National Bank & Trust	003174	62982
Vendor	PO Number	Invoice #	Account Code
4B Farm, LLC	22-1406	4633	24-3100-630-01-00
<b>Sub Total</b>			
Voucher Number	Bank Name	Account Number	Check Number
Bills for January Board Meeting	First National Bank & Trust	003174	62983
Vendor	PO Number	Invoice #	Account Code
AFPLANSERV	22-1387	21113063020	06-2300-300-00-00
<b>Sub Total</b>			
Voucher Number	Bank Name	Account Number	Check Number
Bills for January Board Meeting	First National Bank & Trust	003174	62984
Vendor	PO Number	Invoice #	Account Code
Almena Lumber & Supply	22-1426	010722	06-2300-890-00-30
Almena Lumber & Supply	22-1426	010722	06-2720-626-00-04
Almena Lumber & Supply	22-1426	010722	06-2720-626-00-10
Almena Lumber & Supply	22-1426	010722	06-2720-626-00-13
Almena Lumber & Supply	22-1426	010722	06-2720-626-00-14
Almena Lumber & Supply	22-1426	010722	06-2720-626-00-18
Almena Lumber & Supply	22-1426	010722	06-2720-626-00-19
Almena Lumber & Supply	22-1426	010722	06-2720-626-00-20
Almena Lumber & Supply	22-1426	010722	06-2720-626-00-22
Almena Lumber & Supply	22-1426	010722	06-2720-629-00-13
Almena Lumber & Supply	22-1426	010722	06-2720-629-00-19
Almena Lumber & Supply	22-1426	010722	06-2720-629-00-20
Almena Lumber & Supply	22-1426	010722	06-2720-629-00-22
Almena Lumber & Supply	22-1426	010722	06-2720-730-00-03
Almena Lumber & Supply	22-1426	010722	06-2720-730-00-13
Almena Lumber & Supply	22-1426	010722	06-2720-730-00-19

Almena Lumber & Supply	22-1426	010722	06-2720-730-00-20
Almena Lumber & Supply	22-1426	010722	06-2720-730-00-22
Almena Lumber & Supply	22-1426	010722	06-2720-890-00-03
Almena Lumber & Supply	22-1426	010722	06-2720-890-00-08
Almena Lumber & Supply	22-1426	010722	06-2720-890-00-12
Almena Lumber & Supply	22-1426	010722	06-2720-890-00-13
Almena Lumber & Supply	22-1426	010722	06-2720-890-00-15
Almena Lumber & Supply	22-1426	010722	06-2720-890-00-18
Almena Lumber & Supply	22-1426	010722	06-2720-890-00-19
Almena Lumber & Supply	22-1426	010722	06-2720-890-00-20
Almena Lumber & Supply	22-1426	010722	06-2720-890-00-22
Almena Lumber & Supply	22-1426	010722	06-2720-891-00-19
<b>Sub Total</b>			

<b>Voucher Number</b>	<b>Bank Name</b>	<b>Account Number</b>	<b>Check Number</b>
Bills for January Board Meeting	First National Bank & Trust	003174	62985
<b>Vendor</b>	<b>PO Number</b>	<b>Invoice #</b>	<b>Account Code</b>
Almena Market Inc.	22-1430	010722	06-1000-610-01-09
Almena Market Inc.	22-1430	010722	06-1000-610-01-10
Almena Market Inc.	22-1430	010722	06-2300-890-00-00
Almena Market Inc.	22-1430	010722	06-2400-610-00-00
Almena Market Inc.	22-1430	010722	08-1000-890-01-01
Almena Market Inc.	22-1430	010722	08-2600-610-00-01
Almena Market Inc.	22-1430	010722	24-3100-630-01-00
Almena Market Inc.	22-1430	010722	24-3100-630-03-00
<b>Sub Total</b>			

<b>Voucher Number</b>	<b>Bank Name</b>	<b>Account Number</b>	<b>Check Number</b>
Bills for January Board Meeting	First National Bank & Trust	003174	62986
<b>Vendor</b>	<b>PO Number</b>	<b>Invoice #</b>	<b>Account Code</b>
Cash-Wa Distributing Co Inc	22-1408	010722	24-3100-630-01-00
Cash-Wa Distributing Co Inc	22-1408	010722	24-3100-680-01-00
<b>Sub Total</b>			

<b>Voucher Number</b>	<b>Bank Name</b>	<b>Account Number</b>	<b>Check Number</b>
Bills for January Board Meeting	First National Bank & Trust	003174	62987
<b>Vendor</b>	<b>PO Number</b>	<b>Invoice #</b>	<b>Account Code</b>
Cheney Running Attn: Rich Simmons	22-1393	010722	08-1000-890-01-01
<b>Sub Total</b>			

<b>Voucher Number</b>	<b>Bank Name</b>	<b>Account Number</b>	<b>Check Number</b>
Bills for January Board Meeting	First National Bank & Trust	003174	62988
<b>Vendor</b>	<b>PO Number</b>	<b>Invoice #</b>	<b>Account Code</b>
City Of Almena	22-1414	010722	08-2600-411-01-00

City Of Almena	22-1414	010722	08-2600-411-02-00
City Of Almena	22-1414	010722	08-2600-412-01-00
City Of Almena	22-1414	010722	08-2600-412-02-00
City Of Almena	22-1414	010722	08-2600-421-01-00
City Of Almena	22-1414	010722	34-2600-411-00-00
<b>Sub Total</b>			
<b>Voucher Number</b>	<b>Bank Name</b>	<b>Account Number</b>	<b>Check Number</b>
Bills for January Board Meeting	First National Bank & Trust	003174	62989
<b>Vendor</b>	<b>PO Number</b>	<b>Invoice #</b>	<b>Account Code</b>
City Of Long Island	22-1392	010722	08-2600-411-03-00
City Of Long Island	22-1392	010722	08-2600-412-03-00
City Of Long Island	22-1392	010722	08-2600-421-03-00
<b>Sub Total</b>			
<b>Voucher Number</b>	<b>Bank Name</b>	<b>Account Number</b>	<b>Check Number</b>
Bills for January Board Meeting	First National Bank & Trust	003174	62990
<b>Vendor</b>	<b>PO Number</b>	<b>Invoice #</b>	<b>Account Code</b>
Dealers First Financial L.L.C.	22-1386	163239 163240	16-1000-700-03-00
<b>Sub Total</b>			
<b>Voucher Number</b>	<b>Bank Name</b>	<b>Account Number</b>	<b>Check Number</b>
Bills for January Board Meeting	First National Bank & Trust	003174	62991
<b>Vendor</b>	<b>PO Number</b>	<b>Invoice #</b>	<b>Account Code</b>
Dole Welding & Trenching	22-1384	203	08-2600-400-00-02
<b>Sub Total</b>			
<b>Voucher Number</b>	<b>Bank Name</b>	<b>Account Number</b>	<b>Check Number</b>
Bills for January Board Meeting	First National Bank & Trust	003174	62992
<b>Vendor</b>	<b>PO Number</b>	<b>Invoice #</b>	<b>Account Code</b>
Emily Lowry	22-1422	010722	06-1000-890-00-01
<b>Sub Total</b>			
<b>Voucher Number</b>	<b>Bank Name</b>	<b>Account Number</b>	<b>Check Number</b>
Bills for January Board Meeting	First National Bank & Trust	003174	62993
<b>Vendor</b>	<b>PO Number</b>	<b>Invoice #</b>	<b>Account Code</b>
Engel's Sales & Service, Inc	22-1419	010722	06-2720-730-00-12
<b>Sub Total</b>			
<b>Voucher Number</b>	<b>Bank Name</b>	<b>Account Number</b>	<b>Check Number</b>
Bills for January Board Meeting	First National Bank & Trust	003174	62994
<b>Vendor</b>	<b>PO Number</b>	<b>Invoice #</b>	<b>Account Code</b>
Equity Bank	22-1395	000928	06-2300-529-00-00
<b>Sub Total</b>			

<b>Voucher Number</b>	<b>Bank Name</b>	<b>Account Number</b>	<b>Check Number</b>
Bills for January Board Meeting	First National Bank & Trust	003174	62995
<b>Vendor</b>	<b>PO Number</b>	<b>Invoice #</b>	<b>Account Code</b>
F & A Sales Inc	22-1407	010722	24-3100-630-01-00
F & A Sales Inc	22-1407	010722	24-3100-630-03-00
<b>Sub Total</b>			
<b>Voucher Number</b>	<b>Bank Name</b>	<b>Account Number</b>	<b>Check Number</b>
Bills for January Board Meeting	First National Bank & Trust	003174	62996
<b>Vendor</b>	<b>PO Number</b>	<b>Invoice #</b>	<b>Account Code</b>
Hannah Mongeau	22-1421	010722	06-2400-290-00-00
<b>Sub Total</b>			
<b>Voucher Number</b>	<b>Bank Name</b>	<b>Account Number</b>	<b>Check Number</b>
Bills for January Board Meeting	First National Bank & Trust	003174	62997
<b>Vendor</b>	<b>PO Number</b>	<b>Invoice #</b>	<b>Account Code</b>
Harris School Solutions	22-1402	HAPXT0000393	06-2300-300-00-00
<b>Sub Total</b>			
<b>Voucher Number</b>	<b>Bank Name</b>	<b>Account Number</b>	<b>Check Number</b>
Bills for January Board Meeting	First National Bank & Trust	003174	62998
<b>Vendor</b>	<b>PO Number</b>	<b>Invoice #</b>	<b>Account Code</b>
Hinklel Termite and Pest Control	22-1401	1722	08-2600-425-00-00
Hinklel Termite and Pest Control	22-1391	010722	08-2600-425-00-00
<b>Sub Total</b>			
<b>Voucher Number</b>	<b>Bank Name</b>	<b>Account Number</b>	<b>Check Number</b>
Bills for January Board Meeting	First National Bank & Trust	003174	62999
<b>Vendor</b>	<b>PO Number</b>	<b>Invoice #</b>	<b>Account Code</b>
Hogeland Market	22-1409	010722	24-3100-630-03-00
<b>Sub Total</b>			
<b>Voucher Number</b>	<b>Bank Name</b>	<b>Account Number</b>	<b>Check Number</b>
Bills for January Board Meeting	First National Bank & Trust	003174	63000
<b>Vendor</b>	<b>PO Number</b>	<b>Invoice #</b>	<b>Account Code</b>
Hop-A-Long IT Services	22-1390	915	08-1000-300-00-00
Hop-A-Long IT Services	22-1418	924	08-1000-300-00-00
Hop-A-Long IT Services	22-1418	924	08-1000-700-00-00
<b>Sub Total</b>			
<b>Voucher Number</b>	<b>Bank Name</b>	<b>Account Number</b>	<b>Check Number</b>
Bills for January Board Meeting	First National Bank & Trust	003174	63001
<b>Vendor</b>	<b>PO Number</b>	<b>Invoice #</b>	<b>Account Code</b>

Jamboree Foods	22-1416	010722	06-1000-610-01-10
<b>Sub Total</b>			
<b>Voucher Number</b>	<b>Bank Name</b>	<b>Account Number</b>	<b>Check Number</b>
Bills for January Board Meeting	First National Bank & Trust	003174	63002
<b>Vendor</b>	<b>PO Number</b>	<b>Invoice #</b>	<b>Account Code</b>
Jim Cole	22-1397	010722	06-1000-890-00-02
<b>Sub Total</b>			
<b>Voucher Number</b>	<b>Bank Name</b>	<b>Account Number</b>	<b>Check Number</b>
Bills for January Board Meeting	First National Bank & Trust	003174	63003
<b>Vendor</b>	<b>PO Number</b>	<b>Invoice #</b>	<b>Account Code</b>
Junior Class	22-1400	1722	08-3400-890-01-01
Junior Class	22-1415	01722	08-1000-890-01-01
Junior Class	22-1385	010722	08-3400-890-01-01
<b>Sub Total</b>			
<b>Voucher Number</b>	<b>Bank Name</b>	<b>Account Number</b>	<b>Check Number</b>
Bills for January Board Meeting	First National Bank & Trust	003174	63004
<b>Vendor</b>	<b>PO Number</b>	<b>Invoice #</b>	<b>Account Code</b>
KANSAS ASSOCIATION OF SCHOOL BOARDS	22-1413	19288	06-2300-810-00-01
<b>Sub Total</b>			
<b>Voucher Number</b>	<b>Bank Name</b>	<b>Account Number</b>	<b>Check Number</b>
Bills for January Board Meeting	First National Bank & Trust	003174	63005
<b>Vendor</b>	<b>PO Number</b>	<b>Invoice #</b>	<b>Account Code</b>
Kelli Hueneke	22-1398	010722	06-1000-890-00-02
<b>Sub Total</b>			
<b>Voucher Number</b>	<b>Bank Name</b>	<b>Account Number</b>	<b>Check Number</b>
Bills for January Board Meeting	First National Bank & Trust	003174	63006
<b>Vendor</b>	<b>PO Number</b>	<b>Invoice #</b>	<b>Account Code</b>
Long Island Feed and Grain, LLC	22-1425	010722	06-2720-626-00-03
Long Island Feed and Grain, LLC	22-1425	010722	06-2720-626-00-08
Long Island Feed and Grain, LLC	22-1425	010722	06-2720-626-00-10
Long Island Feed and Grain, LLC	22-1425	010722	06-2720-626-00-11
Long Island Feed and Grain, LLC	22-1425	010722	06-2720-626-00-14
Long Island Feed and Grain, LLC	22-1425	010722	06-2720-626-00-18
<b>Sub Total</b>			
<b>Voucher Number</b>	<b>Bank Name</b>	<b>Account Number</b>	<b>Check Number</b>
Bills for January Board Meeting	First National Bank & Trust	003174	63007
<b>Vendor</b>	<b>PO Number</b>	<b>Invoice #</b>	<b>Account Code</b>

Lou's Sporting Goods	22-1382	APC744266-TB03	08-3400-890-01-01
<b>Sub Total</b>			
<b>Voucher Number</b>	<b>Bank Name</b>	<b>Account Number</b>	<b>Check Number</b>
Bills for January Board Meeting	First National Bank & Trust	003174	63008
<b>Vendor</b>	<b>PO Number</b>	<b>Invoice #</b>	<b>Account Code</b>
Mitch Pugh	22-1396	010722	06-1000-890-00-02
<b>Sub Total</b>			
<b>Voucher Number</b>	<b>Bank Name</b>	<b>Account Number</b>	<b>Check Number</b>
Bills for January Board Meeting	First National Bank & Trust	003174	63009
<b>Vendor</b>	<b>PO Number</b>	<b>Invoice #</b>	<b>Account Code</b>
NCKSEC	22-1388	010722	30-1000-564-00-00
<b>Sub Total</b>			
<b>Voucher Number</b>	<b>Bank Name</b>	<b>Account Number</b>	<b>Check Number</b>
Bills for January Board Meeting	First National Bank & Trust	003174	63010
<b>Vendor</b>	<b>PO Number</b>	<b>Invoice #</b>	<b>Account Code</b>
Nex-Tech (Nex-Tech)	22-1420	010722	06-2300-532-00-00
Nex-Tech (Nex-Tech)	22-1420	010722	06-2300-532-00-01
Nex-Tech (Nex-Tech)	22-1420	010722	06-2400-532-00-00
Nex-Tech (Nex-Tech)	22-1420	010722	06-2400-532-00-01
Nex-Tech (Nex-Tech)	22-1420	010722	06-2400-532-00-02
<b>Sub Total</b>			
<b>Voucher Number</b>	<b>Bank Name</b>	<b>Account Number</b>	<b>Check Number</b>
Bills for January Board Meeting	First National Bank & Trust	003174	63011
<b>Vendor</b>	<b>PO Number</b>	<b>Invoice #</b>	<b>Account Code</b>
Nex-Tech Wireless, LLC	22-1399	8758114	06-2600-890-00-00
Nex-Tech Wireless, LLC	22-1399	8758114	06-2720-890-00-17
<b>Sub Total</b>			
<b>Voucher Number</b>	<b>Bank Name</b>	<b>Account Number</b>	<b>Check Number</b>
Bills for January Board Meeting	First National Bank & Trust	003174	63012
<b>Vendor</b>	<b>PO Number</b>	<b>Invoice #</b>	<b>Account Code</b>
Normandin	22-1412	719 720	08-2600-430-00-02
<b>Sub Total</b>			
<b>Voucher Number</b>	<b>Bank Name</b>	<b>Account Number</b>	<b>Check Number</b>
Bills for January Board Meeting	First National Bank & Trust	003174	63013
<b>Vendor</b>	<b>PO Number</b>	<b>Invoice #</b>	<b>Account Code</b>
Northwest Kansas Library System	22-1381	2113	06-2200-640-01-00
<b>Sub Total</b>			

<b>Voucher Number</b>	<b>Bank Name</b>	<b>Account Number</b>	<b>Check Number</b>
Bills for January Board Meeting	First National Bank & Trust	003174	63014
<b>Vendor</b>	<b>PO Number</b>	<b>Invoice #</b>	<b>Account Code</b>
Northwestern Office Supplies	22-1410	010722	08-1000-610-01-11
Northwestern Office Supplies	22-1410	010722	08-1000-610-02-09
Northwestern Office Supplies	22-1410	010722	08-1000-610-03-09
<b>Sub Total</b>			
<b>Voucher Number</b>	<b>Bank Name</b>	<b>Account Number</b>	<b>Check Number</b>
Bills for January Board Meeting	First National Bank & Trust	003174	63015
<b>Vendor</b>	<b>PO Number</b>	<b>Invoice #</b>	<b>Account Code</b>
Norton County District Court	22-1417	010722	06-2300-890-00-00
<b>Sub Total</b>			
<b>Voucher Number</b>	<b>Bank Name</b>	<b>Account Number</b>	<b>Check Number</b>
Bills for January Board Meeting	First National Bank & Trust	003174	63016
<b>Vendor</b>	<b>PO Number</b>	<b>Invoice #</b>	<b>Account Code</b>
Ostmeyer Inc dba Culligan Soft Water Service	22-1383	010722	08-2600-411-02-00
Ostmeyer Inc dba Culligan Soft Water Service	22-1383	010722	08-2600-411-03-00
Ostmeyer Inc dba Culligan Soft Water Service	22-1405	1722	08-2600-411-02-00
Ostmeyer Inc dba Culligan Soft Water Service	22-1405	1722	08-2600-411-03-00
<b>Sub Total</b>			
<b>Voucher Number</b>	<b>Bank Name</b>	<b>Account Number</b>	<b>Check Number</b>
Bills for January Board Meeting	First National Bank & Trust	003174	63017
<b>Vendor</b>	<b>PO Number</b>	<b>Invoice #</b>	<b>Account Code</b>
Phillips County EMS	22-1394	010722	06-1000-890-01-01
<b>Sub Total</b>			
<b>Voucher Number</b>	<b>Bank Name</b>	<b>Account Number</b>	<b>Check Number</b>
Bills for January Board Meeting	First National Bank & Trust	003174	63018
<b>Vendor</b>	<b>PO Number</b>	<b>Invoice #</b>	<b>Account Code</b>
Pitney Bowes Global Financial Services LLC	22-1389	1019691296	06-2300-590-00-01
<b>Sub Total</b>			
<b>Voucher Number</b>	<b>Bank Name</b>	<b>Account Number</b>	<b>Check Number</b>
Bills for January Board Meeting	First National Bank & Trust	003174	63019
<b>Vendor</b>	<b>PO Number</b>	<b>Invoice #</b>	<b>Account Code</b>
Prairie Land Electric Cooperative, Inc.	22-1431	010722	06-2600-622-01-00
Prairie Land Electric Cooperative, Inc.	22-1431	010722	06-2600-622-03-00
Prairie Land Electric Cooperative, Inc.	22-1431	010722	34-2600-622-00-00
<b>Sub Total</b>			

<b>Voucher Number</b>	<b>Bank Name</b>	<b>Account Number</b>	<b>Check Number</b>
Bills for January Board Meeting	First National Bank & Trust	003174	63020
<b>Vendor</b>	<b>PO Number</b>	<b>Invoice #</b>	<b>Account Code</b>
Purchase Power	22-1423	010722	06-2300-590-00-01
<b>Sub Total</b>			
<b>Voucher Number</b>	<b>Bank Name</b>	<b>Account Number</b>	<b>Check Number</b>
Bills for January Board Meeting	First National Bank & Trust	003174	63021
<b>Vendor</b>	<b>PO Number</b>	<b>Invoice #</b>	<b>Account Code</b>
Sawyer's Ace Hardware	22-1427	010722	08-2600-430-00-01
<b>Sub Total</b>			
<b>Voucher Number</b>	<b>Bank Name</b>	<b>Account Number</b>	<b>Check Number</b>
Bills for January Board Meeting	First National Bank & Trust	003174	63022
<b>Vendor</b>	<b>PO Number</b>	<b>Invoice #</b>	<b>Account Code</b>
Smoky Hill ESC	22-1429	22-0493	08-1000-300-00-00
<b>Sub Total</b>			
<b>Voucher Number</b>	<b>Bank Name</b>	<b>Account Number</b>	<b>Check Number</b>
Bills for January Board Meeting	First National Bank & Trust	003174	63023
<b>Vendor</b>	<b>PO Number</b>	<b>Invoice #</b>	<b>Account Code</b>
US Foods	22-1428	010722	24-3100-630-01-00
US Foods	22-1428	010722	24-3100-630-03-00
<b>Sub Total</b>			
<b>Voucher Number</b>	<b>Bank Name</b>	<b>Account Number</b>	<b>Check Number</b>
Bills for January Board Meeting	First National Bank & Trust	003174	63024
<b>Vendor</b>	<b>PO Number</b>	<b>Invoice #</b>	<b>Account Code</b>
VISA (VISA1)	22-1403	010722	06-1000-590-00-00
VISA (VISA1)	22-1403	010722	06-1000-610-01-11
VISA (VISA1)	22-1403	010722	06-1000-610-02-09
VISA (VISA1)	22-1403	010722	06-2300-890-00-00
VISA (VISA1)	22-1403	010722	06-2300-890-00-30
VISA (VISA1)	22-1403	010722	06-2400-610-00-00
VISA (VISA1)	22-1403	010722	06-2720-626-00-15
VISA (VISA1)	22-1403	010722	07-1000-610-00-00
VISA (VISA1)	22-1403	010722	08-1000-610-01-11
VISA (VISA1)	22-1403	010722	08-1000-890-01-01
VISA (VISA1)	22-1403	010722	08-2600-430-00-01
VISA (VISA1)	22-1403	010722	08-2600-430-00-02
VISA (VISA1)	22-1403	010722	08-2600-610-00-01
VISA (VISA1)	22-1403	010722	24-2600-610-00-00
VISA (VISA1)	22-1403	010722	55-1000-644-00-02
VISA (VISA1)	22-1403	010722	55-1000-650-00-00

<b>Sub Total</b>			
<b>Grand Total</b>			

2 3:47:43 PM

Payee	Amount	Type
Terry Logemann	\$455.29	Accounts Payable
Description	Issue Date	Amount
Retention pay-Classified	01/07/2022	\$455.29
		<b>\$455.29</b>
Payee	Amount	Type
4B Farm, LLC	\$92.16	Accounts Payable
Description	Issue Date	Amount
Invoice number 4633.	01/07/2022	\$92.16
		<b>\$92.16</b>
Payee	Amount	Type
AFPLANSERV	\$16.00	Accounts Payable
Description	Issue Date	Amount
Invoice number 21113063020.	01/07/2022	\$16.00
		<b>\$16.00</b>
Payee	Amount	Type
Almena Lumber & Supply	\$2,702.27	Accounts Payable
Description	Issue Date	Amount
Statement date 12/31/21.	01/07/2022	\$10.00
Statement date 12/31/21.	01/07/2022	\$47.76
Statement date 12/31/21.	01/07/2022	\$116.92
Statement date 12/31/21.	01/07/2022	\$331.78
Statement date 12/31/21.	01/07/2022	\$32.99
Statement date 12/31/21.	01/07/2022	\$386.13
Statement date 12/31/21.	01/07/2022	\$287.71
Statement date 12/31/21.	01/07/2022	\$214.49
Statement date 12/31/21.	01/07/2022	\$394.06
Statement date 12/31/21.	01/07/2022	\$39.98
Statement date 12/31/21.	01/07/2022	\$41.10
Statement date 12/31/21.	01/07/2022	\$36.30
Statement date 12/31/21.	01/07/2022	\$111.84
Statement date 12/31/21.	01/07/2022	\$30.00
Statement date 12/31/21.	01/07/2022	\$50.00
Statement date 12/31/21.	01/07/2022	\$4.50

Statement date 12/31/21.	01/07/2022	\$4.50
Statement date 12/31/21.	01/07/2022	\$6.99
Statement date 12/31/21.	01/07/2022	\$29.55
Statement date 12/31/21.	01/07/2022	\$204.95
Statement date 12/31/21.	01/07/2022	\$3.65
Statement date 12/31/21.	01/07/2022	\$131.12
Statement date 12/31/21.	01/07/2022	\$20.56
Statement date 12/31/21.	01/07/2022	\$80.43
Statement date 12/31/21.	01/07/2022	\$17.93
Statement date 12/31/21.	01/07/2022	\$17.53
Statement date 12/31/21.	01/07/2022	\$34.50
Statement date 12/31/21.	01/07/2022	\$15.00
		<b>\$2,702.27</b>

<b>Payee</b>	<b>Amount</b>	<b>Type</b>
Almena Market Inc.	\$920.80	Accounts Payable

<b>Description</b>	<b>Issue Date</b>	<b>Amount</b>
Charges for December.	01/07/2022	\$55.29
Charges for December.	01/07/2022	\$6.94
Charges for December.	01/07/2022	\$51.14
Charges for December.	01/07/2022	\$77.10
Charges for December.	01/07/2022	\$4.08
Charges for December.	01/07/2022	\$406.64
Charges for December.	01/07/2022	\$204.62
Charges for December.	01/07/2022	\$114.99
		<b>\$920.80</b>

<b>Payee</b>	<b>Amount</b>	<b>Type</b>
Cash-Wa Distributing Co Inc	\$3,418.26	Accounts Payable

<b>Description</b>	<b>Issue Date</b>	<b>Amount</b>
Charges for December.	01/07/2022	\$3,141.76
Charges for December.	01/07/2022	\$276.50
		<b>\$3,418.26</b>

<b>Payee</b>	<b>Amount</b>	<b>Type</b>
Cheney Running Attn: Rich Simmons	\$150.00	Accounts Payable

<b>Description</b>	<b>Issue Date</b>	<b>Amount</b>
Track and Field Clinic registration for 3 people.	01/07/2022	\$150.00
		<b>\$150.00</b>

<b>Payee</b>	<b>Amount</b>	<b>Type</b>
City Of Almena	\$791.78	Accounts Payable

<b>Description</b>	<b>Issue Date</b>	<b>Amount</b>
Statement date 12/29/21.	01/07/2022	\$82.18

Statement date 12/29/21.	01/07/2022	\$143.56
Statement date 12/29/21.	01/07/2022	\$70.00
Statement date 12/29/21.	01/07/2022	\$140.00
Statement date 12/29/21.	01/07/2022	\$250.00
Statement date 12/29/21.	01/07/2022	\$106.04
		<b>\$791.78</b>

<b>Payee</b>	<b>Amount</b>	<b>Type</b>
City Of Long Island	\$119.26	Accounts Payable

<b>Description</b>	<b>Issue Date</b>	<b>Amount</b>
December charges.	01/07/2022	\$58.26
December charges.	01/07/2022	\$40.00
December charges.	01/07/2022	\$21.00
		<b>\$119.26</b>

<b>Payee</b>	<b>Amount</b>	<b>Type</b>
Dealers First Financial L.L.C.	\$455.00	Accounts Payable

<b>Description</b>	<b>Issue Date</b>	<b>Amount</b>
Invoice number 163239 and 163240.	01/07/2022	\$455.00
		<b>\$455.00</b>

<b>Payee</b>	<b>Amount</b>	<b>Type</b>
Dole Welding & Trenching	\$272.24	Accounts Payable

<b>Description</b>	<b>Issue Date</b>	<b>Amount</b>
Invoice number 203.	01/07/2022	\$272.24
		<b>\$272.24</b>

<b>Payee</b>	<b>Amount</b>	<b>Type</b>
Emily Lowry	\$411.60	Accounts Payable

<b>Description</b>	<b>Issue Date</b>	<b>Amount</b>
Semester 1 mileage payment.	01/07/2022	\$411.60
		<b>\$411.60</b>

<b>Payee</b>	<b>Amount</b>	<b>Type</b>
Engel's Sales & Service, Inc	\$637.47	Accounts Payable

<b>Description</b>	<b>Issue Date</b>	<b>Amount</b>
Statement date 12/27/21.	01/07/2022	\$637.47
		<b>\$637.47</b>

<b>Payee</b>	<b>Amount</b>	<b>Type</b>
Equity Bank	\$200.00	Accounts Payable

<b>Description</b>	<b>Issue Date</b>	<b>Amount</b>
Invoice number 000928.	01/07/2022	\$200.00
		<b>\$200.00</b>

<b>Payee</b>	<b>Amount</b>	<b>Type</b>
F & A Sales Inc	\$1,707.44	Accounts Payable
<b>Description</b>	<b>Issue Date</b>	<b>Amount</b>
Charges for December.	01/07/2022	\$728.65
Charges for December.	01/07/2022	\$978.79
		<b>\$1,707.44</b>
<b>Payee</b>	<b>Amount</b>	<b>Type</b>
Hannah Mongeau	\$303.75	Accounts Payable
<b>Description</b>	<b>Issue Date</b>	<b>Amount</b>
Leave payout.	01/07/2022	\$303.75
		<b>\$303.75</b>
<b>Payee</b>	<b>Amount</b>	<b>Type</b>
Harris School Solutions	\$108.40	Accounts Payable
<b>Description</b>	<b>Issue Date</b>	<b>Amount</b>
Invoice number HAPXT0000393.	01/07/2022	\$108.40
		<b>\$108.40</b>
<b>Payee</b>	<b>Amount</b>	<b>Type</b>
Hinklel Termite and Pest Control	\$130.00	Accounts Payable
<b>Description</b>	<b>Issue Date</b>	<b>Amount</b>
Service date 12/17/21 at Long Island.	01/07/2022	\$60.00
Service date 12/17/21.	01/07/2022	\$70.00
		<b>\$130.00</b>
<b>Payee</b>	<b>Amount</b>	<b>Type</b>
Hogeland Market	\$61.52	Accounts Payable
<b>Description</b>	<b>Issue Date</b>	<b>Amount</b>
Statement date 12/13/21.	01/07/2022	\$61.52
		<b>\$61.52</b>
<b>Payee</b>	<b>Amount</b>	<b>Type</b>
Hop-A-Long IT Services	\$2,336.27	Accounts Payable
<b>Description</b>	<b>Issue Date</b>	<b>Amount</b>
Invoice number 915.	01/07/2022	\$318.42
Invoice number 924.	01/07/2022	\$1,128.00
Invoice number 924.	01/07/2022	\$889.85
		<b>\$2,336.27</b>
<b>Payee</b>	<b>Amount</b>	<b>Type</b>
Jamboree Foods	\$3.57	Accounts Payable
<b>Description</b>	<b>Issue Date</b>	<b>Amount</b>

Statement date 1/4/22.	01/07/2022	\$3.57
		<b>\$3.57</b>
<b>Payee</b>	<b>Amount</b>	<b>Type</b>
Jim Cole	\$441.00	Accounts Payable
<b>Description</b>	<b>Issue Date</b>	<b>Amount</b>
Semester 1 mileage payment.	01/07/2022	\$441.00
		<b>\$441.00</b>
<b>Payee</b>	<b>Amount</b>	<b>Type</b>
Junior Class	\$133.00	Accounts Payable
<b>Description</b>	<b>Issue Date</b>	<b>Amount</b>
Reimbursement for concessions.	01/07/2022	\$38.00
Concession stand reimbursement.	01/07/2022	\$40.00
Concession reimbursement for 12/14 HS Basketball game	01/07/2022	\$55.00
		<b>\$133.00</b>
<b>Payee</b>	<b>Amount</b>	<b>Type</b>
KANSAS ASSOCIATION OF SCHOOL BOARDS	\$150.00	Accounts Payable
<b>Description</b>	<b>Issue Date</b>	<b>Amount</b>
Invoice number 19288.	01/07/2022	\$150.00
		<b>\$150.00</b>
<b>Payee</b>	<b>Amount</b>	<b>Type</b>
Kelli Hueneke	\$473.76	Accounts Payable
<b>Description</b>	<b>Issue Date</b>	<b>Amount</b>
Semester 1 mileage payment.	01/07/2022	\$473.76
		<b>\$473.76</b>
<b>Payee</b>	<b>Amount</b>	<b>Type</b>
Long Island Feed and Grain, LLC	\$752.41	Accounts Payable
<b>Description</b>	<b>Issue Date</b>	<b>Amount</b>
Statement date 12/31/2021.	01/07/2022	\$48.58
Statement date 12/31/2021.	01/07/2022	\$43.11
Statement date 12/31/2021.	01/07/2022	\$223.83
Statement date 12/31/2021.	01/07/2022	\$211.94
Statement date 12/31/2021.	01/07/2022	\$14.01
Statement date 12/31/2021.	01/07/2022	\$210.94
		<b>\$752.41</b>
<b>Payee</b>	<b>Amount</b>	<b>Type</b>
Lou's Sporting Goods	\$3.58	Accounts Payable
<b>Description</b>	<b>Issue Date</b>	<b>Amount</b>

Invoice number APC744266-TB03. Already paid the \$7. Shipping was not paid.	01/07/2022	\$3.58
		<b>\$3.58</b>
<b>Payee</b>	<b>Amount</b>	<b>Type</b>
Mitch Pugh	\$388.08	Accounts Payable
<b>Description</b>	<b>Issue Date</b>	<b>Amount</b>
Semester 1 mileage payment.	01/07/2022	\$388.08
		<b>\$388.08</b>
<b>Payee</b>	<b>Amount</b>	<b>Type</b>
NCKSEC	\$37,405.00	Accounts Payable
<b>Description</b>	<b>Issue Date</b>	<b>Amount</b>
December COOP Split	01/07/2022	\$37,405.00
		<b>\$37,405.00</b>
<b>Payee</b>	<b>Amount</b>	<b>Type</b>
Nex-Tech (Nex-Tech)	\$1,267.68	Accounts Payable
<b>Description</b>	<b>Issue Date</b>	<b>Amount</b>
Bill date 1/1/22.	01/07/2022	\$478.52
Bill date 1/1/22.	01/07/2022	\$59.99
Bill date 1/1/22.	01/07/2022	\$179.05
Bill date 1/1/22.	01/07/2022	\$71.59
Bill date 1/1/22.	01/07/2022	\$478.53
		<b>\$1,267.68</b>
<b>Payee</b>	<b>Amount</b>	<b>Type</b>
Nex-Tech Wireless, LLC	\$146.99	Accounts Payable
<b>Description</b>	<b>Issue Date</b>	<b>Amount</b>
Invoice number 8758114.	01/07/2022	\$59.60
Invoice number 8758114.	01/07/2022	\$87.39
		<b>\$146.99</b>
<b>Payee</b>	<b>Amount</b>	<b>Type</b>
Normandin	\$342.00	Accounts Payable
<b>Description</b>	<b>Issue Date</b>	<b>Amount</b>
Invoice number 719 and 720.	01/07/2022	\$342.00
		<b>\$342.00</b>
<b>Payee</b>	<b>Amount</b>	<b>Type</b>
Northwest Kansas Library System	\$19.66	Accounts Payable
<b>Description</b>	<b>Issue Date</b>	<b>Amount</b>
Invoice number 2113.	01/07/2022	\$19.66
		<b>\$19.66</b>

<b>Payee</b>	<b>Amount</b>	<b>Type</b>
Northwestern Office Supplies	\$1,056.21	Accounts Payable
<b>Description</b>	<b>Issue Date</b>	<b>Amount</b>
Statement date 12/31/21.	01/07/2022	\$261.18
Statement date 12/31/21.	01/07/2022	\$525.69
Statement date 12/31/21.	01/07/2022	\$269.34
		<b>\$1,056.21</b>
<b>Payee</b>	<b>Amount</b>	<b>Type</b>
Norton County District Court	\$46.00	Accounts Payable
<b>Description</b>	<b>Issue Date</b>	<b>Amount</b>
Payment for filing.	01/07/2022	\$46.00
		<b>\$46.00</b>
<b>Payee</b>	<b>Amount</b>	<b>Type</b>
Ostmeyer Inc dba Culligan Soft Water Service	\$204.95	Accounts Payable
<b>Description</b>	<b>Issue Date</b>	<b>Amount</b>
Statement date 11/30/21.	01/07/2022	\$58.99
Statement date 11/30/21.	01/07/2022	\$19.00
Statement date 12/31/21.	01/07/2022	\$85.96
Statement date 12/31/21.	01/07/2022	\$41.00
		<b>\$204.95</b>
<b>Payee</b>	<b>Amount</b>	<b>Type</b>
Phillips County EMS	\$375.00	Accounts Payable
<b>Description</b>	<b>Issue Date</b>	<b>Amount</b>
Statement date 12/22/21.	01/07/2022	\$375.00
		<b>\$375.00</b>
<b>Payee</b>	<b>Amount</b>	<b>Type</b>
Pitney Bowes Global Financial Services LLC	\$169.98	Accounts Payable
<b>Description</b>	<b>Issue Date</b>	<b>Amount</b>
Invoice number 1019691296.	01/07/2022	\$169.98
		<b>\$169.98</b>
<b>Payee</b>	<b>Amount</b>	<b>Type</b>
Prairie Land Electric Cooperative, Inc.	\$3,451.29	Accounts Payable
<b>Description</b>	<b>Issue Date</b>	<b>Amount</b>
Statement date 1/06/22.	01/07/2022	\$2,611.85
Statement date 1/06/22.	01/07/2022	\$687.61
Statement date 1/06/22.	01/07/2022	\$151.83
		<b>\$3,451.29</b>

<b>Payee</b>	<b>Amount</b>	<b>Type</b>
Purchase Power	\$150.00	Accounts Payable
<b>Description</b>	<b>Issue Date</b>	<b>Amount</b>
Statement date 12/26/21.	01/07/2022	\$150.00
		<b>\$150.00</b>
<b>Payee</b>	<b>Amount</b>	<b>Type</b>
Sawyer's Ace Hardware	\$277.79	Accounts Payable
<b>Description</b>	<b>Issue Date</b>	<b>Amount</b>
Charges for December.	01/07/2022	\$277.79
		<b>\$277.79</b>
<b>Payee</b>	<b>Amount</b>	<b>Type</b>
Smoky Hill ESC	\$400.00	Accounts Payable
<b>Description</b>	<b>Issue Date</b>	<b>Amount</b>
Invoice number 22-00493.	01/07/2022	\$400.00
		<b>\$400.00</b>
<b>Payee</b>	<b>Amount</b>	<b>Type</b>
US Foods	\$3,754.90	Accounts Payable
<b>Description</b>	<b>Issue Date</b>	<b>Amount</b>
Charges for November and December.	01/07/2022	\$1,211.99
Charges for November and December.	01/07/2022	\$2,542.91
		<b>\$3,754.90</b>
<b>Payee</b>	<b>Amount</b>	<b>Type</b>
VISA (VISA1)	\$4,135.47	Accounts Payable
<b>Description</b>	<b>Issue Date</b>	<b>Amount</b>
Statement date 12/22/21.	01/07/2022	\$335.45
Statement date 12/22/21.	01/07/2022	\$26.95
Statement date 12/22/21.	01/07/2022	\$202.96
Statement date 12/22/21.	01/07/2022	\$186.48
Statement date 12/22/21.	01/07/2022	\$33.70
Statement date 12/22/21.	01/07/2022	\$70.85
Statement date 12/22/21.	01/07/2022	\$36.23
Statement date 12/22/21.	01/07/2022	\$100.00
Statement date 12/22/21.	01/07/2022	\$285.88
Statement date 12/22/21.	01/07/2022	\$376.52
Statement date 12/22/21.	01/07/2022	\$152.04
Statement date 12/22/21.	01/07/2022	\$22.41
Statement date 12/22/21.	01/07/2022	\$1,234.08
Statement date 12/22/21.	01/07/2022	\$15.06
Statement date 12/22/21.	01/07/2022	\$123.49
Statement date 12/22/21.	01/07/2022	\$933.37

		<b>\$4,135.47</b>
		<b>\$70,837.83</b>

# USD 212

## Check Listing Report

Accounting Cycle: FY21-22; Begin Date: 12/14/2021; End Date: 01/07/2022; Bank: [All]; Sort By Element: FUND; Account Expression: [All]; Created On: 1/7/2022 3:47:44 PM

Check Date	Check Number	Payee	Type	Amount
	62982	4B Farm, LLC	Accounts Payable	\$92.16
	62983	AFPLANSERV	Accounts Payable	\$16.00
	62984	Almena Lumber & Supply	Accounts Payable	\$2,702.27
	62985	Almena Market Inc.	Accounts Payable	\$920.80
	62986	Cash-Wa Distributing Co Inc	Accounts Payable	\$3,418.26
	62987	Cheney Running Attn: Rich Simmons	Accounts Payable	\$150.00
	62988	City Of Almena	Accounts Payable	\$791.78
	62989	City Of Long Island	Accounts Payable	\$119.26
	62990	Dealers First Financial L.L.C.	Accounts Payable	\$455.00
	62991	Dole Welding & Trenching	Accounts Payable	\$272.24
	62992	Emily Lowry	Accounts Payable	\$411.60
	62993	Engel's Sales & Service, Inc	Accounts Payable	\$637.47
	62994	Equity Bank	Accounts Payable	\$200.00
	62995	F & A Sales Inc	Accounts Payable	\$1,707.44
	62996	Hannah Mongeau	Accounts Payable	\$303.75
	62997	Harris School Solutions	Accounts Payable	\$108.40
	62998	Hinklel Termite and Pest Control	Accounts Payable	\$130.00
	62999	Hogeland Market	Accounts Payable	\$61.52
	63000	Hop-A-Long IT Services	Accounts Payable	\$2,336.27
	63001	Jamboree Foods	Accounts Payable	\$3.57
	63002	Jim Cole	Accounts Payable	\$441.00
	63003	Junior Class	Accounts Payable	\$133.00
	63004	KANSAS ASSOCIATION OF SCHOOL BOARDS	Accounts Payable	\$150.00
	63005	Kelli Hueneke	Accounts Payable	\$473.76
	63006	Long Island Feed and Grain, LLC	Accounts Payable	\$752.41
	63007	Lou's Sporting Goods	Accounts Payable	\$3.58
	63008	Mitch Pugh	Accounts Payable	\$388.08
	63009	NCKSEC	Accounts Payable	\$37,405.00
	63010	Nex-Tech (Nex-Tech)	Accounts Payable	\$1,267.68
	63011	Nex-Tech Wireless, LLC	Accounts Payable	\$146.99
	63012	Normandin	Accounts Payable	\$342.00
	63013	Northwest Kansas Library System	Accounts Payable	\$19.66
	63014	Northwestern Office Supplies	Accounts Payable	\$1,056.21
	63015	Norton County District Court	Accounts Payable	\$46.00
	63016	Ostmeyer Inc dba Culligan Soft Water Service	Accounts Payable	\$204.95
	63017	Phillips County EMS	Accounts Payable	\$375.00
	63018	Pitney Bowes Global Financial Services LLC	Accounts Payable	\$169.98

	63019	Prairie Land Electric Cooperative, Inc.	Accounts Payable	\$3,451.29
	63020	Purchase Power	Accounts Payable	\$150.00
	63021	Sawyer's Ace Hardware	Accounts Payable	\$277.79
	63022	Smoky Hill ESC	Accounts Payable	\$400.00
	63023	US Foods	Accounts Payable	\$3,754.90
	63024	VISA (VISA1)	Accounts Payable	\$4,135.47
01/07/2022	62981	Terry Logemann	Accounts Payable	\$455.29
<b>Sub Total</b>				<b>\$70,837.83</b>

# USD 212

## Check Listing Report

Accounting Cycle: FY21-22; Begin Date: 12/14/2021; End Date: 01/07/2022; Bank: [All]; Sort By Element: FUND; Account Expression: [All]; Created On: 1/7/2022 3:47:44 PM

Check Date	Check Number	Payee	Description	Type	Amount
	62982	4B Farm, LLC	Inv: 4633	Accounts Payable	\$92.16
	62983	AFPLANSERV	Inv: 21113063020	Accounts Payable	\$16.00
	62984	Almena Lumber & Supply	Inv: 010722	Accounts Payable	\$2,702.27
	62985	Almena Market Inc.	Inv: 010722	Accounts Payable	\$920.80
	62986	Cash-Wa Distributing Co Inc	Inv: 010722	Accounts Payable	\$3,418.26
	62987	Cheney Running Attn: Rich Simmons	Inv: 010722	Accounts Payable	\$150.00
	62988	City Of Almena	Inv: 010722	Accounts Payable	\$791.78
	62989	City Of Long Island	Inv: 010722	Accounts Payable	\$119.26
	62990	Dealers First Financial L.L.C.	Inv: 163239 163240	Accounts Payable	\$455.00
	62991	Dole Welding & Trenching	Inv: 203	Accounts Payable	\$272.24
	62992	Emily Lowry	Inv: 010722	Accounts Payable	\$411.60
	62993	Engel's Sales & Service, Inc	Inv: 010722	Accounts Payable	\$637.47
	62994	Equity Bank	Inv: 000928	Accounts Payable	\$200.00
	62995	F & A Sales Inc	Inv: 010722	Accounts Payable	\$1,707.44
	62996	Hannah Mongeau	Inv: 010722	Accounts Payable	\$303.75
	62997	Harris School Solutions	Inv: HAPXT0000393	Accounts Payable	\$108.40
	62998	Hinklel Termite and Pest Control	Inv: 010722	Accounts Payable	\$70.00
	62998	Hinklel Termite and Pest Control	Inv: 1722	Accounts Payable	\$60.00
	62999	Hogeland Market	Inv: 010722	Accounts Payable	\$61.52
	63000	Hop-A-Long IT Services	Inv: 915	Accounts Payable	\$318.42
	63000	Hop-A-Long IT Services	Inv: 924	Accounts Payable	\$2,017.85
	63001	Jamboree Foods	Inv: 010722	Accounts Payable	\$3.57
	63002	Jim Cole	Inv: 010722	Accounts Payable	\$441.00
	63003	Junior Class	Inv: 010722	Accounts Payable	\$55.00
	63003	Junior Class	Inv: 01722	Accounts Payable	\$40.00
	63003	Junior Class	Inv: 1722	Accounts Payable	\$38.00
	63004	KANSAS ASSOCIATION OF SCHOOL BOARDS	Inv: 19288	Accounts Payable	\$150.00
	63005	Kelli Hueneke	Inv: 010722	Accounts Payable	\$473.76
	63006	Long Island Feed and Grain, LLC	Inv: 010722	Accounts Payable	\$752.41
	63007	Lou's Sporting Goods	Inv: APC744266-TB03	Accounts Payable	\$3.58
	63008	Mitch Pugh	Inv: 010722	Accounts Payable	\$388.08
	63009	NCKSEC	Inv: 010722	Accounts Payable	\$37,405.00
	63010	Nex-Tech (Nex-Tech)	Inv: 010722	Accounts Payable	\$1,267.68
	63011	Nex-Tech Wireless, LLC	Inv: 8758114	Accounts Payable	\$146.99
	63012	Normandin	Inv: 719 720	Accounts Payable	\$342.00
	63013	Northwest Kansas Library System	Inv: 2113	Accounts Payable	\$19.66
	63014	Northwestern Office Supplies	Inv: 010722	Accounts Payable	\$1,056.21

	63015	Norton County District Court	Inv: 010722	Accounts Payable	\$46.00
	63016	Ostmeyer Inc dba Culligan Soft Water Service	Inv: 010722	Accounts Payable	\$77.99
	63016	Ostmeyer Inc dba Culligan Soft Water Service	Inv: 1722	Accounts Payable	\$126.96
	63017	Phillips County EMS	Inv: 010722	Accounts Payable	\$375.00
	63018	Pitney Bowes Global Financial Services LLC	Inv: 1019691296	Accounts Payable	\$169.98
	63019	Prairie Land Electric Cooperative, Inc.	Inv: 010722	Accounts Payable	\$3,451.29
	63020	Purchase Power	Inv: 010722	Accounts Payable	\$150.00
	63021	Sawyer's Ace Hardware	Inv: 010722	Accounts Payable	\$277.79
	63022	Smoky Hill ESC	Inv: 22-0493	Accounts Payable	\$400.00
01/07/2022	62981	Terry Logemann	Inv: 010722	Accounts Payable	\$455.29
	63023	US Foods	Inv: 010722	Accounts Payable	\$3,754.90
	63024	VISA (VISA1)	Inv: 010722	Accounts Payable	\$4,135.47
	<b>Sub Total</b>				<b>\$70,837.83</b>

# USD 212

## Cash Summary Report

Accounting Cycle: FY21-22; Beginning Period: Period 01 (07/01/2021 - 07/31/2021) ; Ending Period: Period 06 (12/01/2021 - 12/31/2021) ; Show Prior Year Expense/Encumbrance: No  
Transactions after the Last Period: None; Exclude Closing Entries: No; Include Unposted Transactions: Yes; Created On: 1/7/2022 3:45:26 PM

Fund	Description	Beginning Balance	Revenue	Expenditure	Other	Ending Balance
06	GENERAL FUND	\$406.34	\$1,252,068.23	(\$1,149,280.29)	\$37,405.00	\$140,599.28
07	FEDERAL FUNDS	(\$2,893.20)	\$0.00	(\$12,272.02)	\$0.00	(\$15,165.22)
08	SUPPLEMENTAL GENERAL FUND	\$59,763.00	\$28,619.38	(\$123,044.33)	\$0.00	(\$34,661.95)
11	FOUR YEAR OLD AT RISK FUND	\$10,300.86	\$0.00	(\$18,967.30)	\$0.00	(\$8,666.44)
13	K-12 AT RISK FUND	\$9,150.75	\$0.00	(\$51,119.88)	\$0.00	(\$41,969.13)
16	CAPITAL OUTLAY	\$150,266.83	\$8,878.60	(\$56,921.22)	\$0.00	\$102,224.21
18	DRIVER TRAINING	\$2,418.70	\$0.00	(\$303.10)	\$0.00	\$2,115.60
24	FOOD SERVICE	\$29,812.44	\$39,304.18	(\$67,049.89)	\$0.00	\$2,066.73
26	PROFESSIONAL DEVELOPMENT FUND	\$9,974.95	\$0.00	(\$1,610.18)	\$0.00	\$8,364.77
30	SPECIAL EDUCATION	\$13,876.24	\$77,045.52	(\$93,236.27)	(\$37,405.00)	(\$39,719.51)
34	VOCATIONAL EDUCATION	\$11,483.24	\$865.03	(\$26,641.95)	\$0.00	(\$14,293.68)
35	GIFTS/GRANTS	\$39,797.05	\$0.00	(\$20,717.39)	\$0.00	\$19,079.66
51	KPERS RETIREMENT CONTRIBUTIONS	(\$158.93)	(\$47,071.91)	(\$46,942.14)	\$0.00	(\$94,172.98)
53	CONTINGENCY FUND	\$225,000.00	\$0.00	\$0.00	\$0.00	\$225,000.00
55	TEXTBOOK RENTAL	\$19,022.10	\$4,445.09	(\$153.00)	\$0.00	\$23,314.19
81	LIBRARY GRANT	\$911.02	\$0.00	\$0.00	\$0.00	\$911.02
85	KS COORDINATED SCHOOL HEALTH	\$1,958.14	\$0.00	\$0.00	\$0.00	\$1,958.14
<b>Sub Total</b>		<b>\$581,089.53</b>	<b>\$1,364,154.12</b>	<b>(\$1,668,258.96)</b>	<b>\$0.00</b>	<b>\$276,984.69</b>

No; Prior Year Ending Balance for Beginning Balance: Yes; Include

<b>Encumbrances</b>	<b>Liabilities</b>	<b>Available</b>
(\$885.38)	\$0.00	\$139,713.90
\$0.00	\$0.00	(\$15,165.22)
(\$27.90)	\$0.00	(\$34,689.85)
\$0.00	\$0.00	(\$8,666.44)
\$0.00	\$0.00	(\$41,969.13)
\$0.00	\$0.00	\$102,224.21
\$0.00	\$0.00	\$2,115.60
(\$3,189.87)	\$0.00	(\$1,123.14)
\$0.00	\$0.00	\$8,364.77
\$0.00	\$0.00	(\$39,719.51)
\$0.00	\$0.00	(\$14,293.68)
\$0.00	\$0.00	\$19,079.66
\$0.00	\$0.00	(\$94,172.98)
\$0.00	\$0.00	\$225,000.00
\$0.00	\$0.00	\$23,314.19
\$0.00	\$0.00	\$911.02
\$0.00	\$0.00	\$1,958.14
<b>(\$4,103.15)</b>	<b>\$0.00</b>	<b>\$272,881.54</b>

# USD 212

## Cash Summary Report

Accounting Cycle: FY21-22; Beginning Period: Period 01 (07/01/2021 - 07/31/2021) ; Ending Period: Period 06 (12/01/2021 - 12/31/2021) ; Show Prior Year Expense/Encumbrance: No; Prior Year Ending Balance for Beginning Balance: Yes; Include Transactions after the Last Period: None; Exclude Closing Entries: No; Include Unposted Transactions: Yes; Created On: 1/7/2022 3:45:26 PM

Fund	Description	Liabilities (Beginning)	Liabilities (Ending)	Cash Journal Entries	Other Total
06	GENERAL FUND	\$0.00	\$0.00	\$0.00	\$0.00
07	FEDERAL FUNDS	\$0.00	\$0.00	\$0.00	\$0.00
08	SUPPLEMENTAL GENERAL FUND	\$0.00	\$0.00	\$0.00	\$0.00
11	FOUR YEAR OLD AT RISK FUND	\$0.00	\$0.00	\$0.00	\$0.00
13	K-12 AT RISK FUND	\$0.00	\$0.00	\$0.00	\$0.00
16	CAPITAL OUTLAY	\$0.00	\$0.00	\$0.00	\$0.00
18	DRIVER TRAINING	\$0.00	\$0.00	\$0.00	\$0.00
24	FOOD SERVICE	\$0.00	\$0.00	\$0.00	\$0.00
26	PROFESSIONAL DEVELOPMENT FUND	\$0.00	\$0.00	\$0.00	\$0.00
30	SPECIAL EDUCATION	\$0.00	\$0.00	\$0.00	\$0.00
34	VOCATIONAL EDUCATION	\$0.00	\$0.00	\$0.00	\$0.00
35	GIFTS/GRANTS	\$0.00	\$0.00	\$0.00	\$0.00
51	KPERS RETIREMENT CONTRIBUTIONS	\$0.00	\$0.00	\$0.00	\$0.00
55	TEXTBOOK RENTAL	\$0.00	\$0.00	\$0.00	\$0.00
<b>Sub Total</b>		<b>\$0.00</b>	<b>\$0.00</b>	<b>\$0.00</b>	<b>\$0.00</b>

# Current Cash Balance

Sorted by Site ID, Group ID, Activity ID.  
From 07/01/2021 to 01/01/2022.

Site ID Group ID	Site Name Group Name	Activity ID	Activity Name	Beginning Cash	Receipts	Disbursements	Adjustments	Cash Balance
<b>NVHS</b>	<b>Northern Valley High School</b>							
<b>A</b>	<b>ATHLETICS</b>							
	1010		HIGH SCHOOL ATHLETICS	3,245.05	7,537.01	9,322.69	-236.88	1,222.49
	<b>A Totals:</b>			3,245.05	7,537.01	9,322.69	-236.88	1,222.49
<b>B</b>	<b>CLUBS &amp; ORGANIZATIONS</b>							
	2010		STUDENT COUNCIL	6,912.12	2,033.79	1,017.72	0.00	7,928.19
	2020		KAY	1,669.25	115.00	35.36	0.00	1,748.89
	2050		HUSKY MUSIC CLUB	1,774.33	150.00	0.00	0.00	1,924.33
	2060		FFA	18,532.26	21,514.46	19,634.78	0.00	20,411.94
	2070		SCHOLARS BOWL	88.77	0.00	0.00	0.00	88.77
	2080		DANCE AND CHEER	8,470.18	43.12	4,196.40	236.88	4,553.78
	2090		FORENSICS	990.36	0.00	0.00	0.00	990.36
	3000		TECHNOLOGY CLUB	828.76	0.00	0.00	0.00	828.76
	3010		FCCLA	66.10	0.00	0.00	0.00	66.10
	3020		VOLLEYBALL CLUB	2,362.86	412.00	1,095.20	0.00	1,679.66
	3050		Interactive Media	1,122.18	25.00	45.67	0.00	1,101.51
	FA		FACS	0.00	0.00	0.00	0.00	0.00
	<b>B Totals:</b>			42,817.17	24,293.37	26,025.13	236.88	41,322.29
<b>C</b>	<b>GRADUATING CLASSES</b>							
	3114		CLASS OF 2014	2,838.60	0.00	0.00	0.00	2,838.60
	3115		CLASS OF 2015	1,341.17	0.00	0.00	0.00	1,341.17
	3116		CLASS OF 2016	27.50	0.00	0.00	0.00	27.50
	3117		CLASS OF 2017	0.00	0.00	0.00	0.00	0.00
	3118		CLASS OF 2018	0.00	0.00	0.00	0.00	0.00
	3119		CLASS OF 2019	2,003.91	0.00	0.00	0.00	2,003.91
	3120		CLASS OF 2020	0.00	0.00	349.90	0.00	-349.90
	3121		CLASS OF 2021	1,747.30	0.00	2.71	0.00	1,744.59
	3122		CLASS OF 2022-SENIORS	3,909.14	267.04	4,105.44	0.00	70.74
	3123		CLASS OF 2023-JUNIORS	2,625.78	7,199.80	5,044.40	0.00	4,781.18
	3124		CLASS OF 2024-SOPHOMORES	3,433.48	35.00	52.71	0.00	3,415.77
	<b>C Totals:</b>			17,926.88	7,501.84	9,555.16	0.00	15,873.56
<b>D</b>	<b>DISTRICT MONIES</b>							
	4020		HIGH SCHOOL PETTY CASH	1,125.00	0.00	0.00	0.00	1,125.00
	<b>D Totals:</b>			1,125.00	0.00	0.00	0.00	1,125.00
<b>E</b>	<b>YEARBOOK</b>							
	7000		YEARBOOK	15,915.43	4,595.00	3,279.55	0.00	17,230.88
	<b>E Totals:</b>			15,915.43	4,595.00	3,279.55	0.00	17,230.88

# Current Cash Balance

Sorted by Site ID, Group ID, Activity ID.  
From 07/01/2021 to 01/01/2022.

Site ID Group ID	Site Name Group Name	Activity ID	Activity Name	Beginning Cash	Receipts	Disbursements	Adjustments	Cash Balance
<b>F</b>								
	<b>MISC</b>							
	7030		GREENHOUSE	41.47	0.00	0.00	0.00	41.47
	7060		BOX TOPS FOR EDUCATION	2,366.52	350.00	711.99	0.00	2,004.53
	7102		Unknown revenue from 2016-2017	0.00	0.00	0.00	0.00	0.00
	8011		Interest Paid To Account	406.48	63.00	0.00	0.00	469.48
			<b>F Totals:</b>	2,814.47	413.00	711.99	0.00	2,515.48
<b>G</b>								
	<b>SALES TAX</b>							
	8010		SALES TAX	-85.72	0.00	-0.02	0.00	-85.70
			<b>G Totals:</b>	-85.72	0.00	-0.02	0.00	-85.70
			<b>NVHS Activity Totals:</b>	83,758.28	44,340.22	48,894.50	0.00	79,204.00
<hr/>								
		Begin Balance	Transfers	Receipts	Disbursements	Adjustments	End Balance	
				44,340.22	48,894.50			
		NVHS Bank Balances:		83,758.28	44,340.22	48,894.50	0.00	79,204.00
<hr/>								
			<b>Report Activity Totals:</b>	83,758.28	44,340.22	48,894.50	0.00	79,204.00

---

# Evaluation of Board/

---

## A. Board Evaluation

- 1 The board responds well to suggestions
- 2 The board appreciates the work done by school personnel
- 3 The board is doing a good job
- 4 The board attends school related functions on a regular basis.
- 5 The board does their job in a professional manner.
- 6 The board does a good job of trying to keep good teachers.
- 7 The board looks out for the best interest of everyone involved in its decision-making.

- 8 The board demonstrates an adequate level of research on topics technical in nature or outside their area of expertise (Research before decision)
- 9 The board acts responsibly in dealing with parental concerns/Complaints involving teachers/coaches

## B. Administration

### Superintendent: Ken Tharman

- 1 Administration treats employees with respect.
- 2 Administration listens and acts on employee concerns.
- 3 Administration supports school activities.
- 4 Administration supports school policy.
- 5 Administration understands the problems faced by employees.

### Pre K-8 Principal: Marvin Gebhard

- 1 Administration treats employees with respect.
- 2 Administration listens and acts on employee concerns.
- 3 Administration supports school activities.
- 4 Administration supports school policy.
- 5 Administration understands the problems faced by employees.

### 9-12 Principal: Ken Tharman

- 1 Administration treats employees with respect.
- 2 Administration listens and acts on employee concerns.
- 3 Administration supports school activities.
- 4 Administration supports school policy.
- 5 Administration understands the problems faced by employees.

### Technology Director: Ryan Hopkins

- 1 Technology Director treats employees with respect.
- 2 Technology Director listens and acts on employee concerns.
- 3 Technology Director supports school activities.
- 4 Technology Director supports school policy.
- 5 Technology Director understands the problems faced by employees

### Activities Director: Jessie Thalheim

- 1                                    **Activities Director treats employees with respect.**
- 2                                    **Activities Director listens and acts on employee concerns.**
- 3                                    **Activities Director supports school activities.**
- 4                                    **Activities Director supports school policy.**
- 5                                    **Activities Director understands the problems faced by employees**

**C. Policy and Attitude**

- 1                                    **The policy and activity manuals of USD #212 accurately reflect the values and priorities of our community.**
- 2                                    **The board and administration are capable of dealing with difficult problems and decisions.**
- 3a                                   **USD #212 places proper emphasis on: Sports**
- 3b                                   **Band & Vocal**
- 3c                                   **Clubs & Organizations**
- 3d                                   **Academics**
- 3e                                   **Vocational training**
- 4                                    **USD #212 is a progressive, viable school system**

**Average per person**

# Administration/Policy

AVERAGE SCORE	#1	#2	#3	#4	#5	#6	#7
4.43	5	5	5	3	5	5	5
4.54	5	5	5	4	5	5	5
4.48	4	5	5	4	5	5	5
4.33	5	NA	3	3	5	5	5
4.48	5	5	5	4	5	5	5
4.24	5	5	5	4	5	5	5
4.34	4	5	5	4	5	5	5
4.18	5	4	5	4	5	5	5
4.35	5	4	5	4	5	5	5
4.40	5	5	5	4	5	5	5
4.24	5	5	5	4	5	5	5
4.68	5	5	5	4	5	5	5
4.60	5	5	5	4	5	5	5
4.40	5	5	5	4	5	5	5
4.46	5	5	5	4	5	5	5
4.25	5	4	5	4	3	5	5
4.88	5	5	5	4	5	5	5
4.67	5	5	5	4	5	5	5
4.42	5	4	5	4	3	5	5
4.36	5	5	5 NA		5	NA	5
4.23	5	5	5 NA		5	NA	5
4.41	5	5	5 NA		5	NA	5
4.45	5	5	5 NA		5	NA	5
4.23	5	5	5 NA		5	NA	5
4.52	5	3	5	4	5	5	5
4.22	5	2	5	4	5	3	5
3.91	3	NA	3	4	5	5	5
4.36	3	NA	5	4	5	5	5
4.14	3	NA	3	4	5	4	5

4.77	5	NA	5	4	5	5	5
4.73	5	NA	5	4	5	5	5
4.73	5	NA	5	4	5	5	5
4.73	5	NA	5	4	5	5	5
4.73	5	NA	5	4	5	5	5

4.64	5	5	5	4	5	5	5
------	---	---	---	---	---	---	---

4.52	5	5	5	4	5	5	5
------	---	---	---	---	---	---	---

4.43	5	5	5	4	5	5	5
------	---	---	---	---	---	---	---

4.29	5	NA	5	4	5	5	5
------	---	----	---	---	---	---	---

4.33	5	NA	5	4	5	5	5
------	---	----	---	---	---	---	---

4.36	5	NA	5	4	5	5	5
------	---	----	---	---	---	---	---

4.23	5	NA	5	4	5	5	5
------	---	----	---	---	---	---	---

4.42	5	5	5	4	5	5	5
------	---	---	---	---	---	---	---

4.81	4.69	4.86	3.95	4.90	4.92	5.00
------	------	------	------	------	------	------

#8	#9	10#	11#	12#	13#	14#	15#	16#
3	5	4	3	5	5 NA		4	1
4	5	5	4	5	5 NA		4	1
4	5	4	4	5	5	3	4	2
4	5	4	4	4	5 NA		3 NA	
4	5	4	5	4	5	3	4	2
4	5	5	4	4	5	3	2	1
3.5	5	4	4	4	5	3	4	1
3.5	5	4	3	3	5	3	4	1
3.5	5	4	3	4	5 NA		4	2
4	5	5	5	5	5	2	3	1
4	5	5	4	5	5	2	2	1
4	5	4	4	5	5	5	4	3
4	5	5	5	3	5	3	4	2
4	5	5	4	4	5	3	3	1
4	5	5	4	4	3	2 NA		5
4	5	5	3	4	2	4 NA		5
4	5	5	4	5	5	5 NA		5
4	5	5	4	4	5	3 NA		5
4	5	5	3	4	2	4 NA		5
4	5	5	5	5	5 NA		3	2
4	5	5	4	5	5 NA		2	2
4	5	4	4	5	5 NA		4	2
4	5	5	5	3	5 NA		4	2
4	5	5	4	4	5 NA		3	1
4	5	5	5	5	5 NA		4	4
4	5	5	4	4	5 NA		4	4
4		4	3	4	5 NA		4	4
4	5	4	3	4	5 NA		4	4
4	5	4	4	4	5 NA		4	4

4	5	5	5	5	5 NA		5	4
4	5	5	4	5	5 NA		5	4
4	5	5	4	5	5 NA		5	4
4	5	5	4	5	5 NA		5	4
4	5	5	4	5	5 NA		5	4

4	5	4	4	5	5	5	4	3
4	5	5	4	4	5	3	4	3
4	4	4	4	5	5 NA		2	3
4	5	4	4	4	5 NA		3	3
4	5	4	4	4	5 NA		3	3
4	5	4	4	3	5 NA		1	3
4	5	4	4	4	5 NA		3	3
4	5	4	3	4	5	4	2	3

<b>3.94</b>	<b>4.86</b>	<b>4.55</b>	<b>3.98</b>	<b>4.33</b>	<b>4.81</b>	<b>3.33</b>	<b>3.57</b>	<b>2.85</b>
-------------	-------------	-------------	-------------	-------------	-------------	-------------	-------------	-------------

17#	18#	19#	20#	21#	22#	23#	24#	25#
5	5	5	5 NA		5	5	5	4
5	5	5	3	5	5	5	5	4
5	5	5	4	5	5	5	5	4
5	5	5	4	5	5	5 NA		2
5	5	5	4	5	5	5	5	3
5	5	5	3	4	5	5	5	2
5	5	5	4	5	5	5	5	3
5	5	5	4	4	5	5	5	2
5	5	5	4	4	5	5	5	3
5	5	5	2	5	5	5	5	4
5	4	5	2	5	5	5	5	3
5	5	5	4	5	5	5	5	5
5	5	5	5	5	5	5	5	5
5	4	5	4	4	5	5	5	5
5	5	5	4	5	5	5	5	2
5	4	5	3	5	5	5	5	2
5	5	5	5	5	5	5	5	5
5	5	5	5	5	5	5	5	3
5	5	5	4	5	5	5	5	4
5	5	5	2	5	5	5	5 NA	
5	4	5	2	5	5	5	5 NA	
5	5	5	4	5	5	5	5 NA	
5	5	5	5	5	5	5	5 NA	
5	4	5	4	4	5	5	5 NA	
5	3	5	4	5	5	5 NA		3
5	2	5	3	5	5	5 NA		3
5	3	5	3	5	5	5 NA		2
5	3	5	5	5	5	5 NA		3
5	2	5	3	5	5	5 NA		3

5	5	5	5	5	5	5 NA		3
5	5	5	5	5	5	5 NA		3
5	5	5	5	5	5	5 NA		3
5	5	5	5	5	5	5 NA		3
5	5	5	5	5	5	5 NA		3
5	5	5	4	5	5	5	5	4
5	5	5	4	4	5	5	5	4
5	5	5	4	3	5	5	5 NA	
5	4	5	3	2	5	5 NA	NA	
5	4	5	4	2	5	5 NA	NA	
5	5	5	4	4	5	5	5 NA	
5	5	5	4	3	5	5 NA	NA	
5	5	5	4	4	5	5	5 NA	
<b>5.00</b>	<b>4.55</b>	<b>5.00</b>	<b>3.90</b>	<b>4.56</b>	<b>5.00</b>	<b>5.00</b>	<b>5.00</b>	<b>3.29</b>

# USD #212 Vehicle Trip Log

Vehicle #: 3

This log is designed to be turned in weekly.

Date	Pre Trip Inspection (See Below)	Driver (by signing you are stating that you have completed the pre-trip inspection)	Number of Passengers	Starting Mileage	Ending Mileage	Route	Activity	FFA	Food Serv.	Special Ed	Inservice	Drivers Ed	Admin.	Vehicle	Reason for
														Expenses	Expense
11-15	✓	Cheri L	841	162696	162727	✓	✓							\$	
11-15	✓	Cheri L	5	162727	162755	✓	✓							\$	
11-16	✓	Cheri L	241	162755	162792	✓	✓							\$	
11-16	✓	Cheri L	1	162792	162802	✓	✓							\$	AAAT Class
12-1	✓	MAA	1	162802	162814	✓	✓							\$	
12-2	✓	Cheri L	722	162814	162851	✓	✓							\$	
12-2	✓	Cheri L	3	162851	162874	✓	✓							\$	

## Pre Trip Inspection

_____	Mirrors (Inside & Out)	_____	Anti-freeze & Belts
_____	Emergency Equipment	_____	Tires & Wheels
_____	Windshields & Windows	_____	Headlights, Marker Lights
_____	Windshield Wipers & Washers	_____	Stoplights, Taillights & Back-Up Lights
_____	Brakes	_____	Signals - Turn & 4-Way
_____	Gauges, Buzzers & Horn	_____	Doors - Close & Latch Properly
_____	Steering & Seatbelt	_____	Back-Up Alarm (Bus Only)
_____	Heater / Defrost	_____	Exhaust System (Bus Only)
_____	Interior Lights - Step & Dome	_____	Springs, Hangers, Body Clamps (Bus Only)
_____	Seats / Floor	_____	Flashers - Yellow, Red, Stop Arm (Bus Only)
_____	Engine Operation - Gas & Oil	_____	Emergency Exits - Windows, Door & Roof (Bus Only)

# USD #212 Vehicle Trip Log

Vehicle #: 8

This log is designed to be turned in weekly for route drivers. For activity drivers, if the log is full, please turn it into the District Office.

Date	Pre Trip Inspection (See Below)	Driver (by signing you are stating that you have completed the pre-trip inspection)	# of Passengers	Starting Mileage	Ending Mileage	Miles Driven	Destination	Activity	Route	Food Service	Special Ed.	Inservice	Drivers Ed.	Administration	Vehicle Expenses & Reason for Expense
11-20-21	✓	Maui BZ	842	235521	235512	38	Route		✓						\$
11-22	✓	Maui BZ	5	235542	235580	28	Route		✓						\$
11-23	✓	Maui BZ	842	235608	235646	38	Route		✓						\$
11-23	✓	Maui BZ	5	235646	235674	28	Route		✓						\$
															\$
															\$
															\$
															\$
															\$
															\$

## Pre Trip Inspection

- \_\_\_\_\_ Mirrors (Inside & Out)
- \_\_\_\_\_ Emergency Equipment
- \_\_\_\_\_ Windshields & Windows
- \_\_\_\_\_ Windshield Wipers & Washers
- \_\_\_\_\_ Brakes
- \_\_\_\_\_ Gauges, Buzzers & Horn
- \_\_\_\_\_ Steering & Seatbelt
- \_\_\_\_\_ Heater / Defrost
- \_\_\_\_\_ Interior Lights - Step & Dome
- \_\_\_\_\_ Seats / Floor
- \_\_\_\_\_ Engine Operation - Gas & Oil

- \_\_\_\_\_ Anti-freeze & Belts
- \_\_\_\_\_ Tires & Wheels
- \_\_\_\_\_ Headlights, Marker Lights
- \_\_\_\_\_ Stoplights, Taillights & Back-Up Lights
- \_\_\_\_\_ Signals - Turn & 4-Way
- \_\_\_\_\_ Doors - Close & Latch Properly
- \_\_\_\_\_ Back-Up Alarm (Bus Only)
- \_\_\_\_\_ Exhaust System (Bus Only)
- \_\_\_\_\_ Springs, Hangers, Body Clamps (Bus Only)
- \_\_\_\_\_ Flashers - Yellow, Red, Stop Arm (Bus Only)
- \_\_\_\_\_ Emergency Exits - Windows, Door & Roof (Bus Only)

# USD #212 FLEET

As Of: 8/31/2021

Number	Make & Year	Capacity	Two to a		Expiration
			Seat	Use	
3	1995 Chevy Suburban	9	----	LI Activity	----
4	2000 Dodge Mini Van	7	----	PreK Route	----
5	2018 Ford Transit	10	----	Almena Activity	----
6	2003 Dodge Mini Van	7	----	LI Administration	----
8	1999 Chevy Suburban	9	----	Almena Activity	----
10	2000 Chevy	22	15	Hogan Route	2025
11	2013 Blue Bird	54	36	Activity	2038
12	1999 Chevy	21	14	Cochran Route	2024
14	2012 Chevy Suburban	8	----	LI Activity	----
15	2019 Ford Transit	10	----	Almena Activity	----
16	2012 Thomas	26	17	Hueneke Route	2037
17	2011 Thomas	71	48	Activity	2036
18	2005 Chevy	28	19	Fischer Route	2030
19	2013 Thomas	35	23	Husted Route	2038
20	2002 International	35	23	Spare Route	2027
30	2008 Chevy Impala	5	----	Almena Administration	----

Other  
Being used as Cochran Route,  
until Cochran gets CDL

Windmill Farms LLC

DBA: Revival Lawn care

709 Cleveland St.

Almena KS, 67622

785-664-8526

[baird@ruraltel.net](mailto:baird@ruraltel.net)

January 7, 2022

Bid For:

Northern Valley Schools

512 Bryant

Almena, KS

Windmill Farms LLC DBA: Revival Lawn Care Submits a bid of \$40.00 per man hour to remove snow from sidewalks.

Thank you

Doyle Baird

STATE OF KANSAS



**PROCLAMATION  
BY THE  
GOVERNOR**

TO THE PEOPLE OF KANSAS, GREETINGS:

WHEREAS, the mission of public schools is to meet the diverse educational needs of all children and prepare them for future success; and

WHEREAS, the Kansas Constitution entrusts the locally elected school board with the maintenance, development and operation of this state's public education system; and

WHEREAS, local school board members are accountable to their local community for accomplishing the mission of public education in Kansas; and

WHEREAS, Kansas public school board members advocate for our communities, our children and our public schools; and

WHEREAS, the members of Kansas public school boards of education are committed to providing an excellent education for every child in each community; and

WHEREAS, locally elected school board members devote countless hours to the governance of our public education system and success of Kansas children.

NOW, THEREFORE, I, Laura Kelly, GOVERNOR OF THE STATE OF KANSAS, do hereby proclaim the month of January 2022 as

**School Board Recognition Month**

in the state of Kansas and I urge all citizens to join in this observation.

DONE: At the Capitol in Topeka  
under the Great Seal of  
the State this 1<sup>st</sup> day of  
January, A.D. 2022

BY THE GOVERNOR:

*Laura Kelly*

*Jan [Signature]*

Secretary of State

*Cheryl [Signature]*

Assistant Secretary of State



## **Join us in thanking our Board of Education**

Public education is the backbone of American society, and local school boards are deeply rooted in U.S. tradition. In fact, in 1966 the people of Kansas amended our state's constitution to specifically call for local public schools that are 'maintained, developed and operated by locally elected boards.'

The six individuals on our board of education are responsible for setting the vision for our local education program and partners with staff and other members of the community to provide the facilities and infrastructure to achieve that vision.

Their service to our school district is voluntary and they spend hundreds of hours serving our school. They research, study and then discuss issues so that they can make informed decisions on countless complex challenges. Too often we forget about the personal sacrifices school board members make.

Each board member is a strong advocate for the success of every child in our schools. They spend hours in meetings and on committees, and also advocate for our schools with elected politicians by speaking out against budget cuts or pushing for policy and program reforms.

Our board of education includes Hilary Van Patten, Shanna Hammond, Laquita Smith, Christopher Rogers, Rich Wenzl, and Steven Whitney.

January 2022 marks the annual observance of School Board Recognition Month. This is a time to shine a light on how local boards prepare today's students to be tomorrow's leaders. Please join with others throughout our district and state to thank you the people who provide leadership for our public schools.

Ken Tharman  
Superintendent / HS Principal  
Northern Valley Schools

January 4, 2022

Dear School Board Members and Mr. Tharman:

I am writing this letter to inform you of my resignation of the Northern Valley High School volleyball coach. I was happy to help out in a time of need, and I really did enjoy being with the girls again. I feel that we had a great season, and I am hopeful the progress will continue in the years to come.

Sincerely,

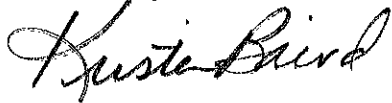
A handwritten signature in cursive script that reads "Kirsten Baird". The signature is written in black ink and is positioned above the printed name.

Kirsten Baird

**MF**  
ATHLETIC

# Everything Track & Field

2022

TRACK  
& FIELD  
CATALOG



800-556-7464  
[mfathletic.com](http://mfathletic.com)

# GILL PV PITS

# POLE VAULT

# POLY PADS

- **12 YEAR WARRANTY.**
- **Strongest vinyl:** 18 oz. knife coated vinyl with 1000 denier woven polyester for unsurpassed strength.
- **Base units feature all vinyl protection** so no water enters casings.
- **Quadruple layer foam** crafted to produce soft landings.

- **2" top pad is standard on all pits** and includes full top of the pit. Vinyl "V" loops connect with carabiner the base units increasing safety.
- **35 degree angled box area** to avoid interference



"V" Loops connect with carabiners to the side of the base units increasing safety.

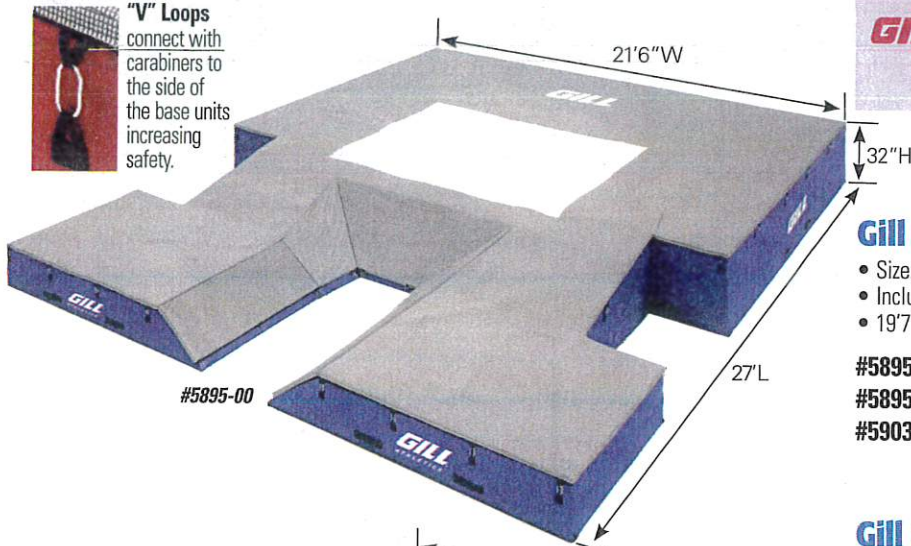

## Gill G6 PV Pit Great pit for all programs!

- Size: 21'6" W x 27' L x 32" H.
- Includes 2" reversible foam top pad, adds safety.
- 19'7" behind the plant box.

#5895-00	G6 PV Pit.....	\$32,475
#5895-WC	Weather Cover .....	\$ 3,235
#5903-01	Custom Logo.....	\$ 1,180

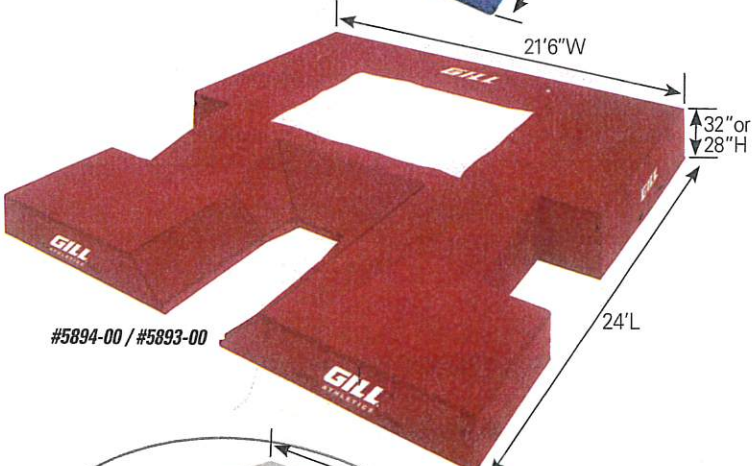

## Gill G4 and S4 PV Pits

Great size pits for both College and High School!  
Two models to choose from; G4 is 32"H and S4 is 28"H and for High School only.

- Size: 21'6" W x 24' L x 32" H, G4 & 28" H S4.
- Includes 2" reversible foam top pad, adds safety.
- 16'7" behind the plant box.

#5894-00	G4 PV Pit (32"H) .....	\$29,440
#5894-WC	Weather Cover for G4.....	\$ 2,940
#5903-01	Custom Logo .....	\$ 1,180
#5893-00	S4 PV Pit (28"H).....	\$26,320
#5893-WC	Weather Cover for S4 .....	\$ 2,615
#5903-01	Custom Logo .....	\$ 1,180

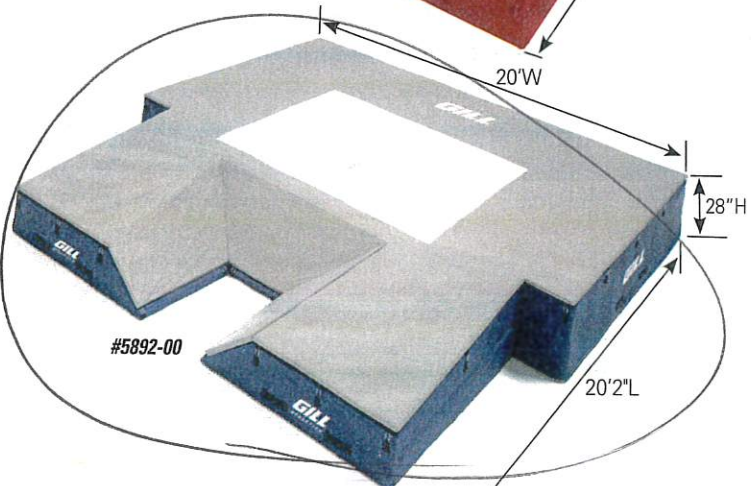

## Gill S1 PV Pit

Meets NFHS Rules!

- Size: 20' W (back) x 16'6" W (front) x 20'2" L x 28" H.
- Includes 2" reversible foam top pad, adds safety.
- 16'7" behind the plant box.

#5892-00	S1 PV Pit.....	\$21,185
#5892-WC	Weather Cover.....	\$ 2,200
#5903-01	Custom Logo .....	\$ 1,180

## GILL S1 PV VALUEPACK SAVE!

Includes: S1 PV Pit, Weather Cover, #5805-01 Scholastic Standards, #5837-02 Base Pads, #523 Essentials Crossbar  
#5926-00 Gill S1 PV Value Package... **\$25,585**

### Gill Pit Colors Available:



**QUICK SHIP: Royal/Gray Colors**

Call for details.

PRICES SUBJECT TO CHANGE.

Everything Track & Field

use credit card | check | school purchase order

PACER

GILL ATHLETICS  
MADE IN U.S.A.  
1-800-637-3000







CALL ATHLETICS  
MADE IN U.S.A.  
1-800-857-2310











ES  
A  
10

Hello,

The Board of Education of USD 212 would like to thank you for your commitment to and investment in our district. We appreciate your contributions, and we want to hear from you regarding what is working well, what is not working well, and what repairs, resources, and initiatives you would like to see prioritized in the coming year.

We will be completing building walkthroughs and staff contacts on Wednesday, January 20<sup>th</sup>, and we would love to visit with you then. We anticipate being in Almena from 8:00-11:30 and in Long Island from 12:00-4:00. We will attend the Spelling Bee and meet at the end of the day to discuss the information we have received.

So that we can make the most efficient and effective use of your time and ours, we have two requests:

1. Please send an e-mail to Hilary Van Patten at [epicliving@protonmail.com](mailto:epicliving@protonmail.com) to advise us of the best time and location to meet with you during the time that we will be in your building. We will do our best to accommodate your request.
2. Please review the following list of questions. You may write your answers in advance and provide them to us when we meet, or you can share your answers verbally on that day.
  - a. Buildings/physical space
    - i. What repairs need to be done?
    - ii. What improvements could be made?
  - b. Supplies
    - i. Do you have everything you need to do your job effectively?
    - ii. What resources are lacking?
  - c. Support
    - i. What can we do to help you thrive?
    - ii. What else do we need to know?

Thanks again, and we look forward to meeting with you.



Fire Alarm Specialist, Inc.  
29073 S Road, WaKeeney, KS 67672  
Phone (785) 743-5287 • Fax (785) 743-5286  
e-mail • firealarmspecialistinc@yahoo.com

**Company Name:** Northern Valley Schools

**Attention:** Ken Tharman

**Job Number:** USD21201

**Date:** December 29, 2021

---

**Job: Fire Alarm 24 Hour Emergency Monitoring:**  
**Northern Valley- Long Island Middle School.**

**Quote: \$400.00- Annually**

Comments: Valid for 30 days. Customer is responsible for supplying stamped plans and code footprint, if required. Customer is required to have 2 phone lines installed prior to the monitoring being installed.

**Signature:** \_\_\_\_\_

**PO#** \_\_\_\_\_



Fire Alarm Specialist, Inc.  
 29073 S Road, WaKeeney, KS 67672  
 phone (785) 743-5287 • fax (785) 743-5286  
 e-mail • firealarmspecialistinc@yahoo.com

**Company Name:** Northern Valley Schools

**Attention:** Ken Tharman

**Job Number:** USD21202

**Date:** December 29, 2021

**Product:**

Radio Communicator

**Description of Product:**

- Dual path communications to central station using Internet or LTE cellular technology.
- Requires no change to the existing Fire Alarm Control Panel configuration with connection to primary and secondary telephone ports.
- Eliminates the cost of two dedicated phone lines.

**Why choose Radio Communicator?**

**Below shows cost of LAN Lines vs Radio Communicator**

LAN Lines		Radio Communicator	
<b>Our Cost:</b>	\$400.00 Annually	<b>Our Cost:</b>	\$800.00 Annually
<b>Phone Line Cost:</b>	\$1,020.00 Annually	<b>No LAN Lines</b>	\$0.00
<b>Total Cost:</b>	\$1,420.00 Annually	<b>Total Cost:</b>	\$800.00 Annually

**Saving by choosing Radio Communicator: \$620.00 per account.**

**Comments:** This quote includes equipment, installation and testing with existing 2 years signed contract. Valid for 30 days. Customer is responsible for supplying stamped plans and code footprint, if required.

**Signature:** \_\_\_\_\_

**PO#** \_\_\_\_\_



Fire Alarm Specialist, Inc.  
29073 S Road, WaKeeney, KS 67672  
phone (785) 743-5287 • fax (785) 743-5286  
e-mail • firealarmspecialistinc@yahoo.com

**Company Name:** Northern Valley Schools

**Attention:** Ken Tharman

**Job Number:** USD21202

**Date:** December 29, 2021

<b><u>Job: Radio Communicator</u></b>	<b><u>Job Number: Northern Valley-Almena High School</u></b>	<b><u>Cost: \$800.00 Annually</u></b>
<b><u>Job: Radio Communicator</u></b>	<b><u>Job Number: Northern Valley-Almena AG Shop</u></b>	<b><u>Cost: \$800.00 Annually</u></b>
<b><u>Total Cost: \$1,600.00 Annually</u></b>		

**Comments:** This quote includes equipment, installation and testing with existing 2 years signed contract. Valid for 30 days. Customer is responsible for supplying stamped plans and code footprint, if required.

**Signature:** \_\_\_\_\_

**PO#** \_\_\_\_\_



900 S.W. Jackson Street, Suite 102  
 Topeka, Kansas 66612-1212  
 (785) 296-3201  
 www.ksde.org

**INTEREST RATE ON INVESTMENT**  
*Effective 1/03/22 through 1/09/22*

**Date:** January 3, 2022  
**To:** Chief School Administrators  
**From:** Craig Neuenswander  
 Deputy Commissioner  
 Dale Brungardt  
 Director of School Finance

TERM	CURRENT	PREVIOUS
1 to 89 Days	<b>0.08%</b>	0.08%
3 Months	<b>0.05%</b>	0.03%
6 Months	<b>0.17%</b>	0.13%
1 Year	<b>0.40%</b>	0.33%
18 Months	<b>0.60%</b>	0.53%
2 Years	<b>0.75%</b>	0.69%

**Payment Dates**

Jan 6 ..... Selected Federal Payments (if requested)  
 Jan 14 ..... KPERs

Payment amounts will be posted on the [School Finance homepage](#) near the date of deposit. Payments are listed under the heading: **FY22 Payments**

**State** aid payments: [Rose Ireland](#) (785) 296-4973 or [Sara Barnes](#) (785) 296-4972  
**Federal** aid payments: (Form 240): [Nicole Norwood](#) (785) 296-2020

**Report Due Dates**

Jan 3-13 ..... Kansas Pre-Kindergarten Pilot (KPP-TANF) 2nd Quarter Expense Reimbursement Payment Request [Nicole Norwood](#) (785) 296-2020  
 Jan 3-20 ..... Request for February Federal Funds (Form 240) if funds available (open Jan 3-20) [Nicole Norwood](#) (785) 296-2020  
 Jan 7 ..... KIDS Collection SMSC- Rural Education Achievement Program (REAP) funding (submit by Jan 7) [KSDE Helpdesk](#) (785) 296-7935  
 Jan 12 ..... Unencumbered Cash Balances on January 1 (all USDs - open Dec 30-Jan 12) [Rose Ireland](#) (785) 296-4973  
 Jan 14 ..... IDEA Maintenance of Effort and Excess Cost Report (all USDs) [Christy Weiler](#) (785) 296-1712

**Federal mileage rate increases to 58.5 cents**

Does your board set the district's privately-owned vehicle (POV) mileage reimbursement based on state or federal rates? *Effective January 1, 2022*, the federal rate was increased by 2.5 cents to **58.5 cents per mile**. At this time, the FY22 state rate remains 56.0 cents per mile.

Dec 17, 2021 - IRS issues standard mileage rates for 2022:  
<https://www.irs.gov/newsroom/irs-issues-standard-mileage-rates-for-2022>



900 S.W. Jackson Street, Suite 600  
Topeka, Kansas 66612-1212  
(785) 296-3203

## Jean Clifford

*Member*  
District 5

(620) 275-4317 - Home  
(620) 271-3673 - Cellular  
jclifford@ksde.org  
www.ksde.org

January 3, 2022

Dear Supt Tharman, Staff and Board,

Congratulations on receiving a Kansans Can Star Recognition Gold Award for High School Graduation, Copper Award for Postsecondary Success and a Commissioner's Award with Honors! These are important achievements and I want to offer my thanks and appreciation to you, your teachers, staff and the USD 212 Board of Education for your hard work and effort in making this possible. You are making a significant difference in the lives of your students and their future success!

Sincerely,

A handwritten signature in cursive script that reads "Jean Clifford".

Jean Clifford

Kansas State Board of Education District 5 Member

# SCHOOL YEAR REQUIREMENT

## FREQUENTLY ASKED QUESTIONS ON 1,116 HOURS



### 1. What are the school year requirements?

[K.S.A. 72-3115](#) "The school term shall consist of not less than 186 school days for pupils attending kindergarten or any of the grades one through 11 and not less than 181 school days for pupils attending grade 12.

"(b) Subject to a policy developed and adopted by it, the board of any school district may provide for a school term consisting of school hours." "For pupils attending kindergarten, not less than 465 school hours in each school year; and (2) for pupils attending any of the grades one through 11, not less than 1,116 school hours in each school year; and (3) for pupils attending grade 12, not less than 1,086 school hours in each school year."

### 2. When and how must the 1,116 hour policy be adopted by the local board of education?

Local boards of education must adopt a policy authorizing the 1,116 hour method. The Kansas State Department of Education (KSDE) must receive this information no later than September 15 of each school year. In August, KSDE will e-mail instructions to all unified school districts how to submit this information electronically, which will constitute written notification. This policy must be adopted each school year if the local board of education elects the 1,116 hour policy. It is not necessary to adopt a policy if the board wants to go with the (186), 6-hour day method.

### 3. Is there a problem adopting the 1,116 hour policy but maintaining (186), 6-hour day schedule?

Many districts have adopted a 1,116 hour policy but have continued with their regular 186-day schedule. This does allow some flexibility in the yearly schedule if the school is attending more than 6 hours.

### 4. In determining the number of hours for the school district, should each individual building receive 1,116 hours?

All school districts must be "open for business" for at least 1,116 hours. However, for seniors, each student is entitled to 1,086 hours. *Each building, therefore, must be in session at least a minimum of 1,116 hours.*

### 5. What common activities can and cannot be counted toward 1,116 hours?

The beginning time is the moment when students and teachers are engaged in educational activities. A tardy bell generally signifies the beginning time of school. The ending time is when students are dismissed from the classroom.

- a. Passing periods, after the end of each class, between opening and closing bells can be considered part of the school day.
- b. Organized recesses not exceeding 15 minutes in length (one mid-morning and one mid-afternoon for elementary schools only) can be considered part of the school day. *However, recess immediately preceding or following lunch is not considered part of the school day.*
- c. Activity periods which all students are required to attend and attendance records are maintained can be counted as a part of the school day.
- d. Lunch periods and passing periods following lunch periods are not considered part of the school day.
- e. Some schools have a mid-morning and/or mid-afternoon "break," consisting of 10-15 minutes. "Break" periods are not considered part of the school day.
- f. Activity periods which students are not required to attend cannot be counted as part of the school day.



## 1,116 Hour Building Log Calculator

Each attendance center is required to track daily attendance. To maintain these records, the Fiscal Auditing office has provided a **1116 Hour Log (Daily Attendance Log)** for tracking minutes/hours. This Excel template will track daily student attendance time, parent teacher conference times, inservice times, and work day hours. A summary page at the bottom of the worksheet automatically totals student attendance hours for seniors and all other students. Your auditor will request to examine all prior year attendance logs to verify the hours students attended met the minimum school year requirement.

Fiscal Auditing homepage: <https://www.ksde.org/Agency/Fiscal-and-Administrative-Services/Fiscal-Auditing>

Look under the heading **Calculators**

Select: **1116 Hour Building Log Calculator**

If you have questions using this calculator, call the Fiscal Auditing office at (785) 296-4976.

- Laurel Murdie, Director [lmurdie@ksde.org](mailto:lmurdie@ksde.org)

The **Enrollment Handbook** is also available on the [KSDE Fiscal Auditing](#) homepage under **Audit Guides**. The handbook summarizes how to count students for funding purposes and is an essential reference for any staff member who will be entering student data into the Kansas Individual Data on Students (KIDS) system.

## Age requirement for school attendance:

**K.S.A. 72-3118** states a child must reach age 5 on or before **August 31** to enter kindergarten.

The only exception is if there is proof the child was already enrolled and attending a kindergarten program in another state prior to Kansas.

There is no upper age limit for entering high school.

###

For more information, contact:

Dale Brungardt  
Director  
School Finance  
(785) 296-3872  
[DBrungardt@ksde.org](mailto:DBrungardt@ksde.org)



Kansas State Department of Education  
900 S.W. Jackson Street, Suite 102  
Topeka, Kansas 66612-1212  
(785) 296-3201  
[www.ksde.org](http://www.ksde.org)

T:guidelines and manuals/1116hrs statute FAQ

## Early Release to Work Special Request

Second semester senior students at Northern Valley High School who have a 2.0 or better GPA and have attended regularly may in some cases be released early from school to work. This program will require attendance in school part of a day and work part of a day.

To request this program, the following criteria are established:

- A. The pupil's parents must request in writing, to the Student Success Coordinator (SSC), their desire to have their student participate in the early release to work program. (Found on page 4 of this form)
- B. The student will submit the completed Reason for Request form found in Google Doc requesting early release from school to work. (Found on Page 3 of this form) The form needs to be done via Microsoft Word or Google Docs, not handwritten (per board request).
- C. The SSC and Principal will review the student's needs, academic records and other necessary criteria. The principal will make a recommendation to the Board of Education.
- D. The Board of Education will evaluate each student request individually and make a determination.
- E. The student must attend morning classes before they are allowed to go to work each afternoon. The student must maintain employment until 4:00 PM every school day. Additional time must be worked out between the employer and employee. The employer will be responsible for contacting the school if the job status changes.
- F. If the job status changes, the student must work with the school to find a new job. Any student that does not work with the school to maintain employment will forfeit their right to participate in graduation ceremonies.
- G. If at any time the student finds themselves on the failing list, they will NOT be allowed to attend their work release until they are off.

Early Release to Work Special Request

**Student Name:**

**Address:**

**Date of Request:**

**Name of Business where you will be employed :**

**Type of employment position:**

**Business phone number:**

**Employer Name:**

**Employer's signature:**

**Reason for request:** Use an additional sheet of paper; Typed, Times New Roman, Font Size 12, Double Spaced, 500 words maximum. Use professional formatting. Including Name, Title, and Date at the top of your paper.

**Principal comments:**

**BOE Approval** \_\_\_\_\_ **BOE Disapproval** \_\_\_\_\_

**Comments:**

Student Name

Request for Work Release

Date

To: Northern Valley School Board

Early Work Release Permission Form

I \_\_\_\_\_ request that my child  
\_\_\_\_\_ be released from school early to participate in the Early  
Work Release program. I understand that once my child leaves school grounds they are to go  
directly to work. I also understand that once my child leaves, the school is not liable for their  
actions.

\_\_\_\_\_

Signature

\_\_\_\_\_

Date