

GRANTON AREA SCHOOL DISTRICT
217 NORTH MAIN STREET
SPECIAL SCHOOL BOARD MEETING
THURSDAY, MAY 19, 2022 @ 5:00 PM
GRANTON SCHOOL CONFERENCE ROOM 112

I. REGULAR BUSINESS

- A. Call to Order
- B. Roll Call
- C. Verification of Notice to Public
- D. Pledge of Allegiance
- E. Approval of Agenda

II. AGENDA ITEMS

- A. Parking Lot Bids
- B. Personnel

III. EXECUTIVE SESSION

- A. Convene in Executive Session for the purpose of discussing/taking action under Wisconsin Statute 19.85 (1)(c) Considering employment, promotion, compensation or performance evaluation data of any public employee over which the governmental body has jurisdiction or exercises responsibility.
- B. Return to Open Session

IV. ADJOURNMENT

This meeting notice may be supplemented in order to comply with Wisconsin's open meetings law. If this notice is supplemented, the final notice will be posted and provided to the media no later than 24 hours prior to the meeting or no later than 2 hours prior to the meeting, in the event of an emergency.

SOUTH PARKING LOT RECONSTRUCTION

GRANTON AREA SCHOOL DISTRICT CLARK COUNTY, WI

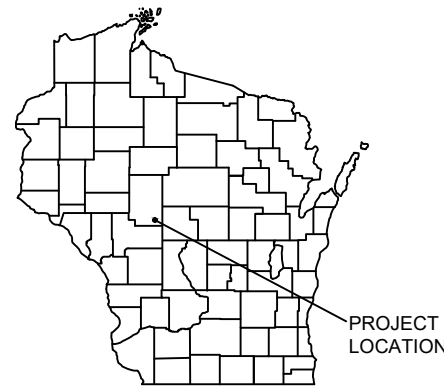

PROJECT LOCATION

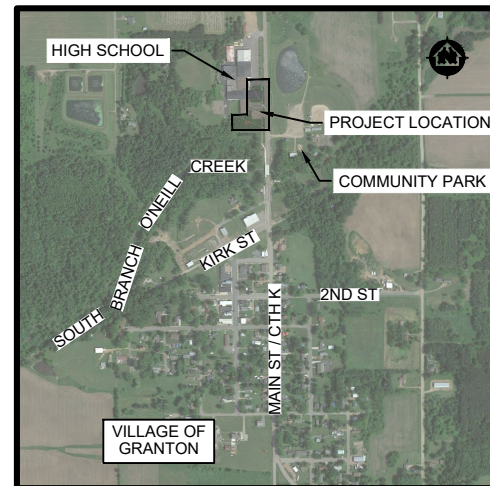

LOCATION MAP
NOT TO SCALE

SHEET INDEX

C000'S - GENERAL / DETAIL SHEETS

- C 001 TITLE SHEET
- C 002-004 EROSION CONTROL DETAILS
- C 005-007 STORM SEWER DETAILS
- C 008-013 SITE DETAILS
- C 014 BIORETENTION BASIN TYPICAL SECTIONS & OVERFLOW STRUCTURE DETAIL
- C 015 PARKING LOT, SIDEWALK, AND DRIVEWAY TYPICAL SECTIONS
- C 016 BUILDING SUMP PUMP 1 CONNECTION DETAIL
- C 017 BUILDING SUMP PUMP 2 CONNECTION DETAIL
- C 018 BUILDING DRAIN AND SUMP PUMP 3 CONNECTION DETAIL

C100'S - EXISTING SITE PLAN SHEETS

- C 100 EXISTING SITE CONDITIONS
- C 101 REMOVAL PLAN

C200'S - PROPOSED SITE PLAN SHEETS

- C 200 PROPOSED SITE PLAN
- C 201 EROSION CONTROL PLAN
- C 202 UTILITY PLAN
- C 203 NORTH SIDEWALK GRADING PLAN
- C 204 PARKING LOT GRADING PLAN
- C 205 BIORETENTION BASIN AND SOUTH SIDEWALK GRADING PLAN
- C 206 PARKING LOT LAYOUT PLAN

LEGEND

- W — EXISTING WATER MAIN
- W — G — EXISTING WATER MAIN, VALVE & HYDRANT
- W — S — EXISTING WATER SERVICE & CURB STOP
- W — G — PROPOSED WATER MAIN, VALVE, & HYDRANT
- W — S — PROPOSED WATER SERVICE & CURB STOP
- SW — S — EXISTING SANITARY SEWER & MANHOLE
- SW — G — PROPOSED SANITARY SEWER & MANHOLE
- FM — EXISTING FORCEMAIN
- SS — EXISTING STORM SEWER & INLET
- SS — G — PROPOSED STORM SEWER & INLET
- SS — S — PROPOSED STORM SEWER & MANHOLE
- E — BURIED ELECTRIC
- G — BURIED GAS & VALVE
- TV — BURIED CABLE TELEVISION
- T — BURIED TELEPHONE
- FO — BURIED FIBER OPTICS
- OH — OVERHEAD UTILITY
- R — RAILROAD TRACKS
- C — EXISTING CURB & GUTTER
- C — G — PROPOSED CURB & GUTTER
- S — EXISTING SIDEWALK
- S — G — PROPOSED SIDEWALK
- CP — EXISTING CULVERT PIPE
- CP — G — PROPOSED CULVERT PIPE
- F — FENCE LINE
- D — DRAINAGE ARROW
- S — SILT FENCE
- R — RIGHT-OF-WAY
- B — BASELINE
- P — PROPERTY LINE
- T — TREE LINE
- B — BENCHMARK
- I — IRON PIPE
- R — IRON ROD
- C — CONTROL POINT
- U — UTILITY POLE & GUY
- S — SOIL BORING
- L — LIGHT POLE
- P — PEDESTAL
- S — STREET SIGN
- M — MAILBOX
- F — FLAGPOLE
- D — TREE - DECIDUOUS
- C — TREE - CONIFEROUS
- X — TREE TO BE REMOVED

UTILITIES

GAS:

JEREMY SLOWINSKI
1921 8TH STREET SOUTH
WISCONSIN RAPIDS WI, 54494
EMAIL: JEREMY.SLOWINSKI@WE-ENERGIES.COM
PHONE: (715) 421-7251

ELECTRIC:

PAM DENZINE
500 NORTH 5TH STREET
ABBOTSFORD WI, 54702
EMAIL: PAMELA.DENZINE@XCELENERGY.COM
PHONE: (715) 218-6637

TELEPHONE:

BECKY RASMUSSEN
420 HEWETT STREET
NEILLSVILLE WI, 54456
EMAIL: BECKY.RASMUSSEN@TDSTELECOM.COM
PHONE: (608) 220-9812

SEWER & WATER:

JOSH OPELT
210 MAPLE STREET BOX 69
GRANTON WI, 54439
EMAIL: GRANTONCLERK@TDS.NET
PHONE: (715) 238-7339

CATV:

JESSE GRUNY
503 EAST IVES STREET, #316
MARSHFIELD WI, 54449
EMAIL: JESSE.GRUNY@CHARTER.COM
PHONE: (715) 651-5605

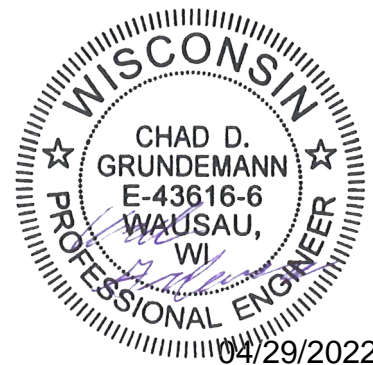

DIGGERS HOTLINE
Dial 811 or (800) 242-8511
www.DiggersHotline.com

NOTE:
UTILITY LOCATIONS SHOWN ON PLANS ARE APPROXIMATE AND CONTRACTOR SHALL HAVE APPROPRIATE UTILITY MARK EXACT LOCATIONS PRIOR TO CONSTRUCTION.

PROJECT DATE:	DRAWN BY:	NO.	DATE	REVISION	BY:
	JFK				
	JFK				
	CDG				



ENGINEERING | ARCHITECTURE | SURVEYING
FUNDING | PLANNING | ENVIRONMENTAL
146 North Central Ave, Marshfield WI 54449
(715) 384-2133 www.msa-ps.com
© MSA Professional Services, Inc.

GRANTON SCHOOLS SOUTH PARKING LOT
GRANTON AREA SCHOOL DISTRICT
CLARK COUNTY, WISCONSIN

TITLE PAGE

PROJECT NO.
1486602
SHEET
C001

**CONSTRUCTION SITE
EROSION CONTROL REQUIREMENTS**

- SECTION NR216.46 OF WISCONSIN STATE ADMINISTRATIVE CODE IDENTIFIES REQUIREMENTS FOR CONSTRUCTION SITE AND POST-CONSTRUCTION EROSION CONTROL. IT IS THE INTENT OF THESE PLANS TO SATISFY THESE REQUIREMENTS. THE METHODS AND STRUCTURES USED TO CONTROL EROSION SHALL BE THE RESPONSIBILITY OF THE CONTRACTOR. CONTRACTOR SHALL IMPLEMENT AN APPROPRIATE MEANS OF CONTROLLING EROSION DURING SITE OPERATION AND UNTIL THE VEGETATION IS RE-ESTABLISHED. ADJUSTMENTS TO THE CONTROL SYSTEM SHALL BE MADE AS REQUIRED.
- ALL WORK SHALL BE IN ACCORDANCE WITH THE LATEST EDITION OF THE WISCONSIN DNR'S CONSERVATION PRACTICE STANDARDS. THESE STANDARDS ARE PERIODICALLY UPDATED AND IT IS THE CONTRACTOR'S RESPONSIBILITY TO OBTAIN AND REFERENCE THE MOST RECENTLY RELEASED STANDARD.
- THIS INFORMATION IS ONLY ONE PART OF THE OVERALL EROSION CONTROL REQUIREMENTS. ADDITIONAL REQUIREMENTS MAY ALSO BE SHOWN ON THE CONTRACT DRAWINGS AND IN THE ACCOMPANYING SPECIFICATIONS.
- ADDITIONAL EROSION CONTROL MEASURES, AS REQUESTED IN WRITING BY THE STATE OR LOCAL INSPECTORS, OR THE OWNER'S ENGINEER, SHALL BE INSTALLED WITHIN 24 HOURS.
- THE AREA OF EROSION EXPOSED TO THE ELEMENTS BY GRUBBING, EXCAVATION, TRENCHING, BORROW AND FILL OPERATIONS AT ANY ONE TIME SHALL BE MINIMIZED TO THE MAXIMUM EXTENT PRACTICABLE. FOR ANY DISTURBED AREA THAT REMAINS INACTIVE FOR GREATER THAN 7 WORKING DAYS, OR WHERE GRADING WORK EXTENDS BEYOND THE PERMANENT SEEDING DEADLINES, THE SITE MUST BE TREATED WITH TEMPORARY STABILIZATION MEASURES SUCH AS SOIL TREATMENT, TEMPORARY SEEDING AND/OR MULCHING. ALL DISTURBED AREAS SHALL BE TREATED WITH PERMANENT STABILIZATION MEASURES WITHIN 3 WORKING DAYS OF FINAL GRADING.
- ALL EROSION CONTROL MEASURES AND STRUCTURES SERVING THE SITE MUST BE INSPECTED AT LEAST WEEKLY OR WITHIN 24 HOURS OF THE TIME 0.5 INCHES OF RAIN HAS OCCURRED. ALL NECESSARY REPAIR AND MAINTENANCE WILL BE DONE AT THIS INSPECTION TIME.
- ALL EROSION CONTROL DEVICES AND/OR STRUCTURES SHALL BE PROPERLY INSTALLED PRIOR TO CLEARING AND GRUBBING OPERATIONS WITHIN THEIR RESPECTIVE DRAINAGE AREAS. THESE SHALL BE PROPERLY MAINTAINED FOR MAXIMUM EFFECTIVENESS UNTIL VEGETATION IS RE-ESTABLISHED.
- ALL EROSION CONTROL DEVICES SHALL BE PROPERLY INSTALLED PRIOR TO ANY SOIL DISTURBANCE.
- ANY SLOPES STEEPER THAN 3H:1V SHALL BE STAKED WITH EROSION CONTROL FABRIC UNLESS INDICATED ON THE PLAN.
- ALL WASTE AND UNUSED BUILDING MATERIALS (INCLUDING GARBAGE, DEBRIS, CLEANING WASTES, WASTEWATER, TOXIC MATERIALS, OR HAZARDOUS MATERIALS) SHALL BE PROPERLY DISPOSED OF AND NOT ALLOWED TO BE CARRIED OFF-SITE BY RUNOFF OR WIND.
- WIND EROSION SHALL BE KEPT TO A MINIMUM DURING CONSTRUCTION. WATERING, MULCH, OR A TACKING AGENT MAY BE REQUIRED TO PROTECT NEARBY RESIDENCES AND WATER RESOURCES.
- CHANNELIZED RUNOFF ENTERING THE PROJECT SITE FROM ADJOINING LANDS SHALL BE DIVERTED THROUGH NATURALLY OR ARTIFICIALLY EROSION-RESISTANT CONVEYANCES. IF CHANNELIZED RUNOFF CANNOT BE DIVERTED, SITE BEST MANAGEMENT PRACTICES MUST ACCOUNT FOR THE ADDITIONAL FLOW RATES AND EROSION POTENTIAL THAT SUCH RUNOFF PRESENTS.
- THE CONTRACTOR SHALL TAKE ALL POSSIBLE PRECAUTIONS TO PREVENT SOILS FROM BEING TRACKED ONTO PUBLIC OR PRIVATE ROADWAYS. PAVED SURFACES ADJACENT TO CONSTRUCTION SITE VEHICLE ACCESS SHALL BE SWEEPED AND/OR SCRAPED (NOT FLUSHED) PERIODICALLY TO REMOVE SOIL, DIRT, AND/OR DUST.
- EROSION CONTROLS SHALL BE INSTALLED ON THE DOWNSTREAM SIDE OF TEMPORARY STOCKPILES. ANY SOIL STOCKPILE THAT REMAINS FOR MORE THAN 30 DAYS SHALL BE COVERED OR TREATED WITH STABILIZATION PRACTICES SUCH AS TEMPORARY OR PERMANENT SEEDING AND MULCHING. ALL STOCK PILES SHALL BE PLACED AT LEAST 75 FEET FROM STREAMS OR WETLANDS.
- ADDITIONAL EROSION CONTROL FOR UTILITY CONSTRUCTION (STORM SEWER, SANITARY SEWER, WATER MAIN, ETC.) SHALL INCLUDE THE FOLLOWING:
 - PLACE EXCAVATED TRENCH MATERIAL ON THE HIGH SIDE OF THE TRENCH.
 - BACKFILL, COMPACT, AND STABILIZE THE TRENCH IMMEDIATELY AFTER PIPE CONSTRUCTION.
 - DISCHARGE OF TRENCH WATER OR DEWATERING EFFLUENT MUST BE PROPERLY TREATED TO REMOVE SEDIMENT IN ACCORDANCE WITH THE WDNR CONSERVATION PRACTICE STANDARD 1061 - DEWATERING OR A SUBSEQUENT WDNR DEWATERING STANDARD PRIOR TO DISCHARGE INTO A STORM SEWER, DITCH, DRAINAGEWAY, OR WETLAND OR LAKE.
- ALL DRAINAGE CULVERTS, STORM DRAIN INLETS, MANHOLES, OR ANY OTHER EXISTING STRUCTURES THAT COULD BE DAMAGED BY SEDIMENTATION SHALL BE PROTECTED ACCORDING TO THE VARIOUS METHODS PROVIDED IN THE PRINTED CONSERVATION PRACTICE STANDARDS.
- ANY SOIL EROSION THAT OCCURS AFTER FINAL GRADING AND/OR STABILIZATION MUST BE REPAIRED AND THE STABILIZATION WORK REDONE.
- THE FIRST SIX WEEKS AFTER INITIAL STABILIZATION, ALL NEWLY SEEDED AND MULCHED AREAS SHALL WATERED WHENEVER 7 DAYS ELAPSE WITHOUT A RAIN EVENT.
- WHEN THE DISTURBED AREA HAS BEEN STABILIZED BY PERMANENT VEGETATION OR OTHER MEANS, TEMPORARY BMP'S SUCH AS SILT FENCES, STRAW BALES, AND SEDIMENT TRAPS SHALL BE REMOVED AND THESE AREAS STABILIZED.
- ALL TEMPORARY BEST MANAGEMENT PRACTICES SHALL BE MAINTAINED UNTIL THE SITE IS STABILIZED.
- ALL DISTURBED AREAS SHALL BE PERMANENTLY STABILIZED WITH SEED AND MULCH UNLESS OTHERWISE SPECIFIED. A MINIMUM OF FOUR INCHES OF TOPSOIL SHALL BE APPLIED TO ALL AREAS TO BE SEEDED OR SODDED.

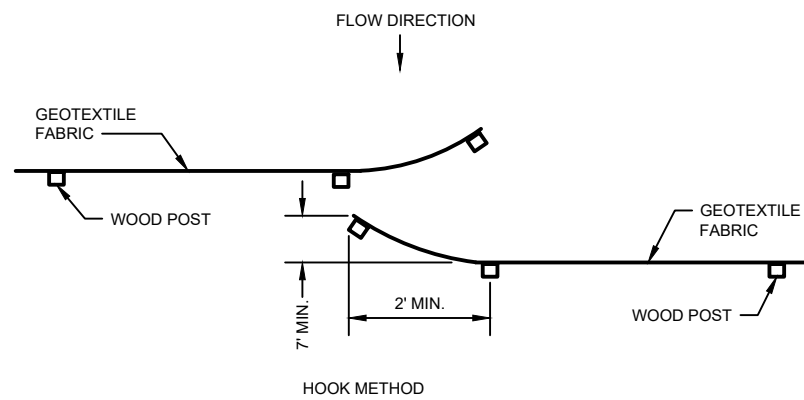
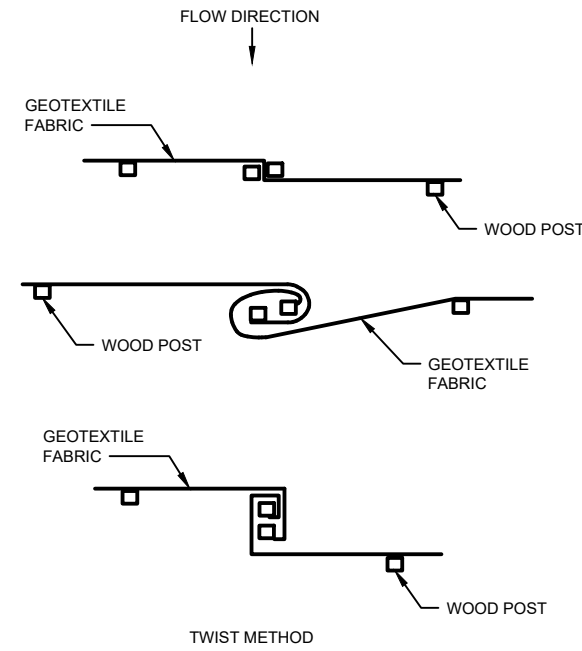

JOINING TWO LENGTHS OF SILT FENCE ③

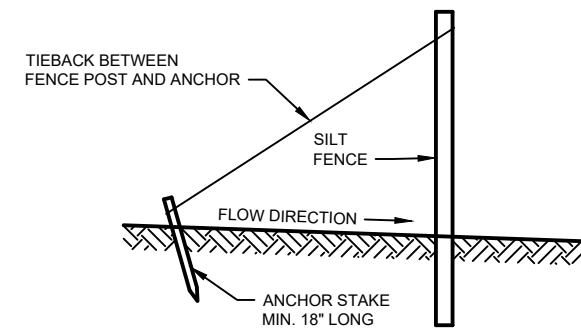

SILT FENCE TIE BACK
(WHEN REQUIRED BY THE ENGINEER)

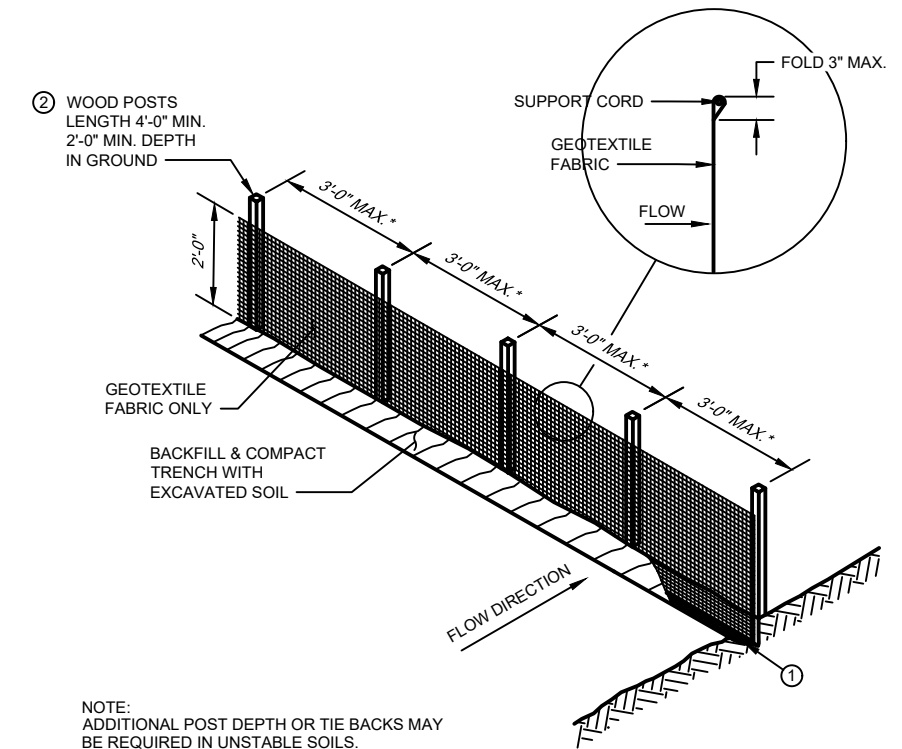

NOTE:
ADDITIONAL POST DEPTH OR TIE BACKS MAY BE REQUIRED IN UNSTABLE SOILS.

* 8'-0" POST SPACING ALLOWED IF A WOVEN GEOTEXTILE FABRIC IS USED, OR IF THE SILT FENCE IS FACTORY ASSEMBLED.

ATTACH THE FABRIC TO THE POSTS WITH WIRE STAPLES OR WOODEN LATH AND NAILS.

SILT FENCE

GENERAL NOTES

- TRENCH SHALL BE A MINIMUM OF 4" WIDE & 6" DEEP TO BURY AND ANCHOR THE GEOTEXTILE FABRIC. FOLD MATERIAL TO FIT TRENCH AND BACKFILL & COMPACT TRENCH WITH EXCAVATED SOIL.
- WOOD POSTS SHALL BE A MINIMUM SIZE OF 1 1/8" x 1 1/8" OF OAK OR HICKORY.
- CONSTRUCT SILT FENCE FROM A CONTINUOUS ROLL IF POSSIBLE BY CUTTING LENGTHS TO AVOID JOINTS. IF A JOINT IS NECESSARY USE ONE OF THE FOLLOWING TWO METHODS: A) TWIST METHOD -- OVERLAP THE END POSTS AND TWIST, OR ROTATE, AT LEAST 180 DEGREES, B) HOOK METHOD -- HOOK THE END OF EACH SILT FENCE LENGTH.

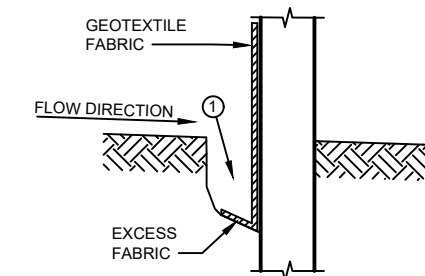

TRENCH DETAIL

PROJECT DATE:	DRAWN BY:	NO.	DATE	REVISION	BY:
	JFK				
	JFK				
	CDG				

PLOT DATE: 4/29/2022 4:06 PM, G:\1414866\1486602\CADD\Construction Documents\PLAN PRODUCTION DRAWINGS\GENERAL AND DETAILS.dwg



ENGINEERING | ARCHITECTURE | SURVEYING
FUNDING | PLANNING | ENVIRONMENTAL
146 North Central Ave, Marshfield WI 54449
(715) 384-2133 www.msa-ps.com
© MSA Professional Services, Inc.

GRANTON SCHOOLS SOUTH PARKING LOT
GRANTON AREA SCHOOL DISTRICT
CLARK COUNTY, WISCONSIN

EROSION CONTROL DETAILS

PROJECT NO.
1486602
SHEET
C002

GENERAL NOTES - INLET PROTECTION

INLET PROTECTION DEVICES SHALL BE MAINTAINED OR REPLACED AT THE DIRECTION OF THE ENGINEER. MANUFACTURED ALTERNATIVES APPROVED AND LISTED ON THE DEPARTMENT'S EROSION CONTROL PRODUCT ACCEPTABILITY LIST MAY BE SUBSTITUTED. WHEN REMOVING OR MAINTAINING INLET PROTECTION, CARE SHALL BE TAKEN SO THAT THE SEDIMENT TRAPPED ON THE GEOTEXTILE FABRIC DOES NOT FALL INTO THE INLET. ANY MATERIAL FALLING INTO THE INLET SHALL BE REMOVED IMMEDIATELY.

1. FINISHED SIZE, INCLUDING FLAP POCKETS WHERE REQUIRED, SHALL EXTEND A MINIMUM OF 10' AROUND THE PERIMETER TO FACILITATE MAINTENANCE OR REMOVAL.
2. FOR INLET PROTECTION, TYPE C (WITH CURB BOX), AN ADDITIONAL 18" OF FABRIC IS WRAPPED AROUND THE WOOD AND SECURED WITH STAPLES. THE WOOD SHALL NOT BLOCK THE ENTIRE HEIGHT OF THE CURB BOX OPENING.
3. FLAP POCKETS SHALL BE LARGE ENOUGH TO ACCEPT WOOD 2X4.

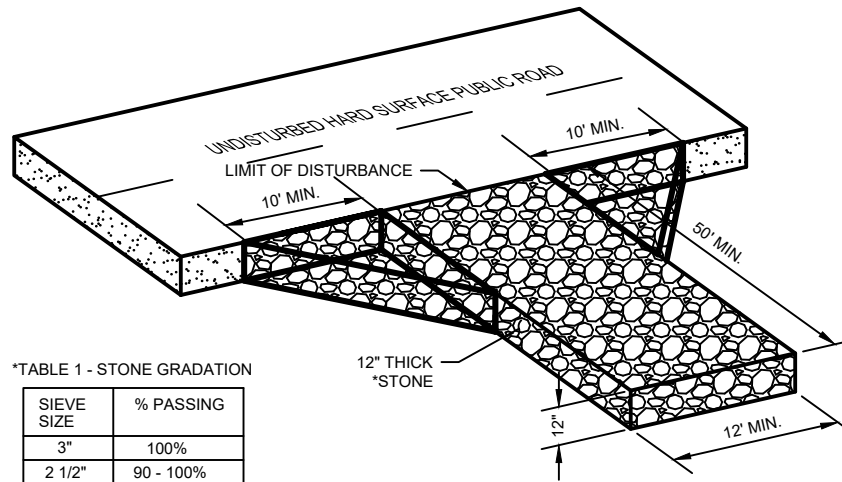

*TABLE 1 - STONE GRADATION

SIEVE SIZE	% PASSING
3"	100%
2 1/2"	90 - 100%
1 1/2"	25 - 60%
3/4"	0 - 20%
3/8"	0 - 5%

NOTES:

1. TRACKING PAD WIDTH SHALL BE AT LEAST THE FULL WIDTH OF THE EGRESS POINT OR 12' WIDE MINIMUM.
2. TRACKING PAD LENGTH SHALL BE 50' FOR CONSTRUCTION SITES, 30' FOR SINGLE FAMILY RESIDENTIAL, OR AS SPECIFIED IN THE CONTRACT DOCUMENTS. LENGTH OF TRACKING PAD MAY NEED TO BE INCREASED OR ADDITIONAL SEDIMENT CONTROL PRACTICES SHALL BE INSTALLED BY THE CONTRACTOR IF SEDIMENT TRACK-OUT OCCURS.
3. GEOTEXTILE FABRIC TYPE R SHALL BE INSTALLED BETWEEN THE STONE AND SUBGRADE ON SITES WHERE HIGH GROUND WATER IS OBSERVED.
4. CONTRACTOR SHALL CLEAN STREET/ROADWAY ADJACENT TO ALL CONSTRUCTION ACCESS POINTS AT THE END OF EACH WORKDAY OR MORE FREQUENTLY IF REQUESTED.

STONE TRACKING PAD

NO SCALE

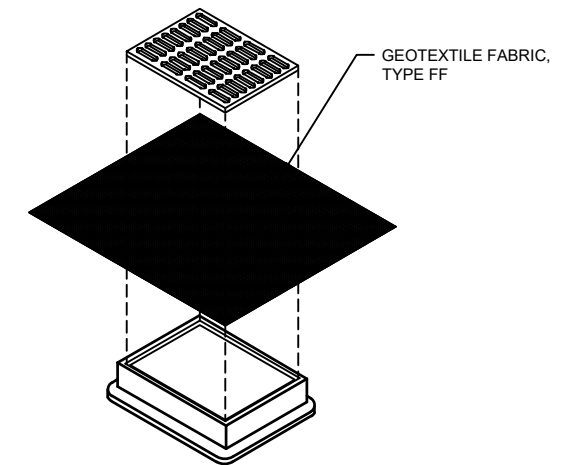

INSTALLATION NOTES:

TRIM EXCESS FABRIC IN THE FLOW LINE TO WITHIN 3" OF THE GRATE. THE CONTRACTOR SHALL DEMONSTRATE A METHOD OF MAINTENANCE, USING A SEWN FLAP, HAND HOLDS OR OTHER METHOD TO PREVENT ACCUMULATED SEDIMENT FROM ENTERING THE INLET.

INLET PROTECTION, TYPE B

NO SCALE

WITHOUT CURB BOX. CAN BE INSTALLED IN ANY INLET WITHOUT A CURB BOX.

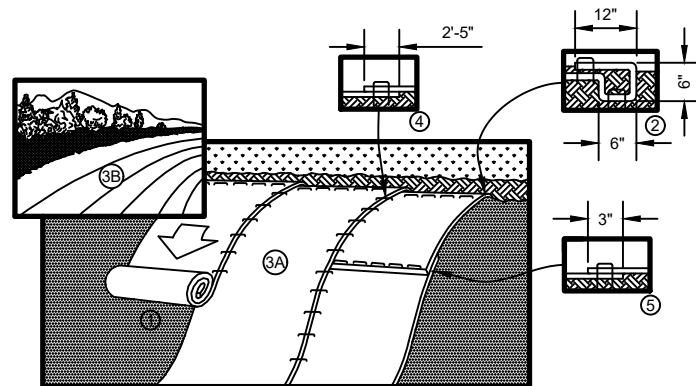

1. PREPARE SOIL BEFORE INSTALLING BLANKETS, INCLUDING ANY NECESSARY APPLICATION OF LIME, FERTILIZER, AND SEED.
2. BEGIN AT THE TOP OF THE SLOPE BY ANCHORING THE BLANKET IN A 6" (15 CM) DEEP X 6" (15 CM) WIDE TRENCH WITH APPROXIMATELY 12" (30cm) OF BLANKET EXTENDED BEYOND THE UP-SLOPE PORTION OF THE TRENCH. ANCHOR THE BLANKET WITH A ROW OF STAPLES/STAKES APPROXIMATELY 12" (30 CM) APART IN THE BOTTOM OF THE TRENCH. BACKFILL AND COMPACT THE TRENCH AFTER STAPLING. APPLY SEED TO COMPACTED SOIL AND FOLD REMAINING 12" (30 CM) PORTION OF BLANKET BACK OVER SEED AND COMPACTED SOIL. SECURE BLANKET OVER COMPACTED SOIL WITH A ROW OF STAPLES/STAKES SPACED APPROXIMATELY 12" (30 CM) APART ACROSS THE WIDTH OF THE BLANKET.
3. ROLL THE BLANKETS (A) DOWN OR (B) HORIZONTALLY ACROSS THE SLOPE. BLANKETS WILL UNROLL WITH APPROPRIATE SIDE AGAINST THE SOIL SURFACE. ALL BLANKETS MUST BE SECURELY FASTENED TO SOIL SURFACE BY PLACING STAPLES/STAKES IN APPROPRIATE LOCATIONS AS SHOWN IN THE STAPLE PATTERN GUIDE.
4. THE EDGES OF PARALLEL BLANKETS MUST BE STAPLED WITH APPROXIMATELY 2'-5" (5 CM-12.5 CM) OVERLAP DEPENDING ON BLANKET TYPE.
5. CONSECUTIVE BLANKETS SPICED DOWN THE SLOPE MUST BE PLACED END OVER END (SHINGLE STYLE) WITH AN APPROXIMATE 3" (7.5 CM) OVERLAP. STAPLE THROUGH OVERLAPPED AREA, APPROXIMATELY 12" (30 CM) APART ACROSS ENTIRE BLANKET WIDTH.

NOTE:

*IN LOOSE SOIL CONDITIONS, THE USE OF STAPLE OR STAKE LENGTHS GREATER THAN 6" (15 CM) MAY BE NECESSARY TO PROPERLY SECURE THE BLANKETS.

EROSION CONTROL BLANKET DETAIL

NO SCALE

TABLE OF QUANTITIES
RIPRAP AT RCP OUTLETS

DIA. OF ROUND PIPE (IN.)	L (FT.)	12" DEPTH RIPRAP (CU.YDS.)	18" DEPTH RIPRAP (CU.YDS.)	24" DEPTH RIPRAP (CU.YDS.)
12	8	2.8	4.1	5.5
15	8	2.9	4.4	5.8
18	10	3.9	5.9	7.8
21	10	4.2	6.3	8.4
24	12	5.5	8.3	11.0
27	12	5.8	8.7	11.6
30	14	7.3	10.9	14.5
36	16	9.2	13.8	18.3
42	18	10.9	16.3	21.7
48	20	12.9	19.4	25.8

TABLE OF QUANTITIES
RIPRAP AT HERCP OUTLETS
OR BOXES OF EQUIVALENT SPAN WIDTH

SPAN OF HERCP (IN.)	L (FT.)	LIGHT RIPRAP d50=6" (CU.YDS.)	MEDIUM RIPRAP d50=9" (CU.YDS.)	HEAVY RIPRAP d50=12" (CU.YDS.)
22	10	3.9	5.9	7.8
30	12	5.5	8.2	10.9
38	14	7.2	10.8	14.3
45	16	9.2	13.7	18.3
53	18	10.9	16.3	21.7
60	20	12.7	19.0	25.4

RIP RAP AT OUTLETS

NO SCALE

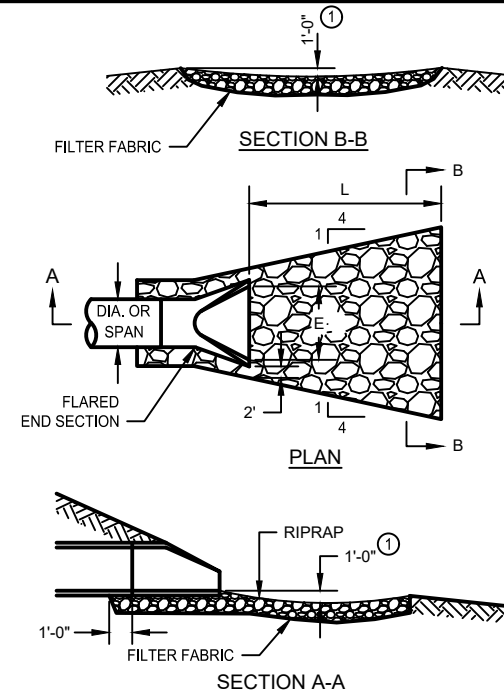

NOTES:

PIPE SIZES LARGER THAN THOSE SHOWN REQUIRE A SPECIAL DESIGN.

LIGHT RIPRAP SHALL BE UNDERLAIN WITH TYPE R FABRIC. MEDIUM AND HEAVY SHALL BE UNDERLAIN W/ TYPE HR FABRIC.

1. FOR PIPES GREATER THAN OR EQUAL TO 30" USE 1.5'.

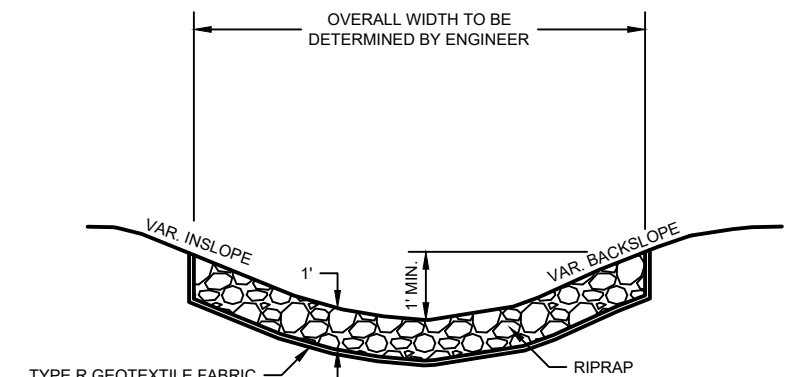

TYPICAL RIPRAP INSTALLATION

NO SCALE

PROJECT DATE:	NO.	DATE	REVISION	BY:
DESIGNED BY: JFK				
CHECKED BY: CDG				



ENGINEERING | ARCHITECTURE | SURVEYING
FUNDING | PLANNING | ENVIRONMENTAL
146 North Central Ave, Marshfield WI 54449
(715) 384-2133 www.msa-ps.com
© MSA Professional Services, Inc.

GRANTON SCHOOLS SOUTH PARKING LOT
GRANTON AREA SCHOOL DISTRICT
CLARK COUNTY, WISCONSIN

EROSION CONTROL DETAILS

PROJECT NO:
1486602
SHEET
C003

WOOD STAKES (2 PER BALE)
NOMINAL 2" X 2" X 30" MIN.
LENGTH OR EQUIVALENT

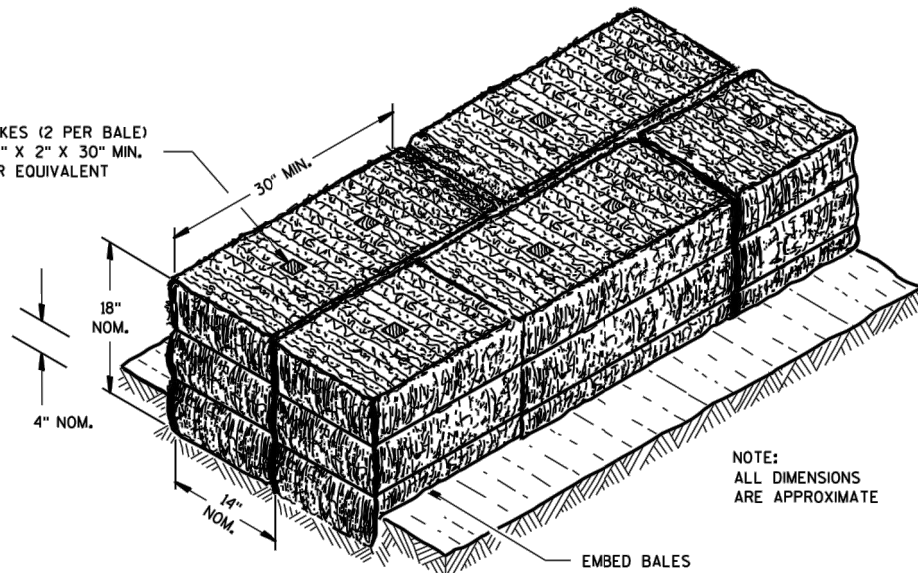

NOTE:
ALL DIMENSIONS
ARE APPROXIMATE

EMBED BALES

SECTION A-A

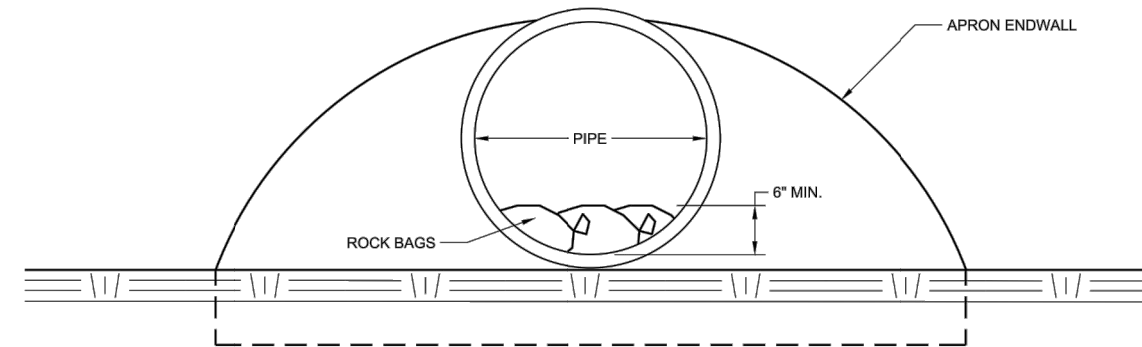

END VIEW

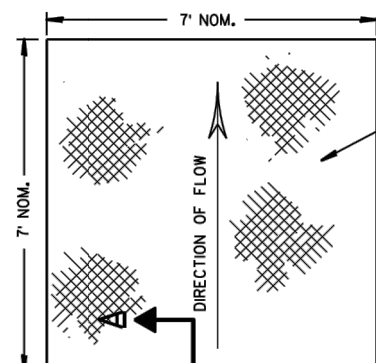

FOR SCOUR PROTECTION USE:
EROSION MAT FOR CHANNEL LINING.
LAP MAT UNDER UPSTREAM BALES
AND SECURE FABRIC WITH WOOD STAKES,
AT 3-FOOT INTERVALS.

PLAN VIEW

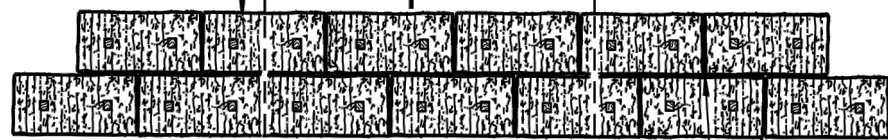

STAGGER JOINTS BETWEEN ADJACENT
ROWS OF BALES.

BOTTOM ELEVATION OF END BALE SHALL
BE EQUAL TO OR GREATER THAN TOP OF
LOWEST MIDDLE BALE.

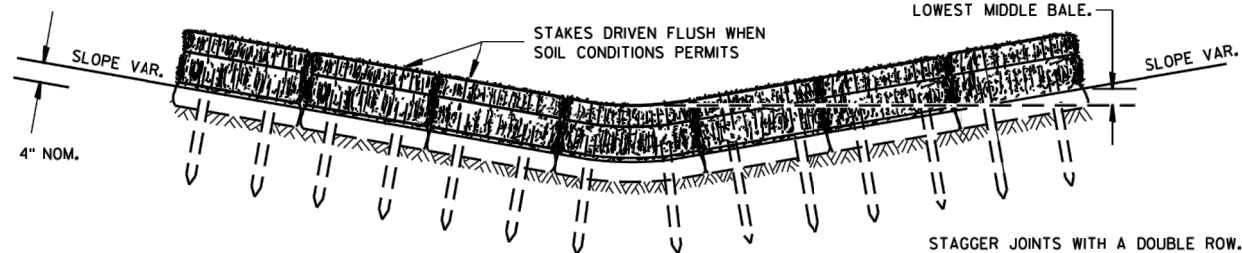

FRONT ELEVATION

TEMPORARY DITCH CHECK USING EROSION BALES ①

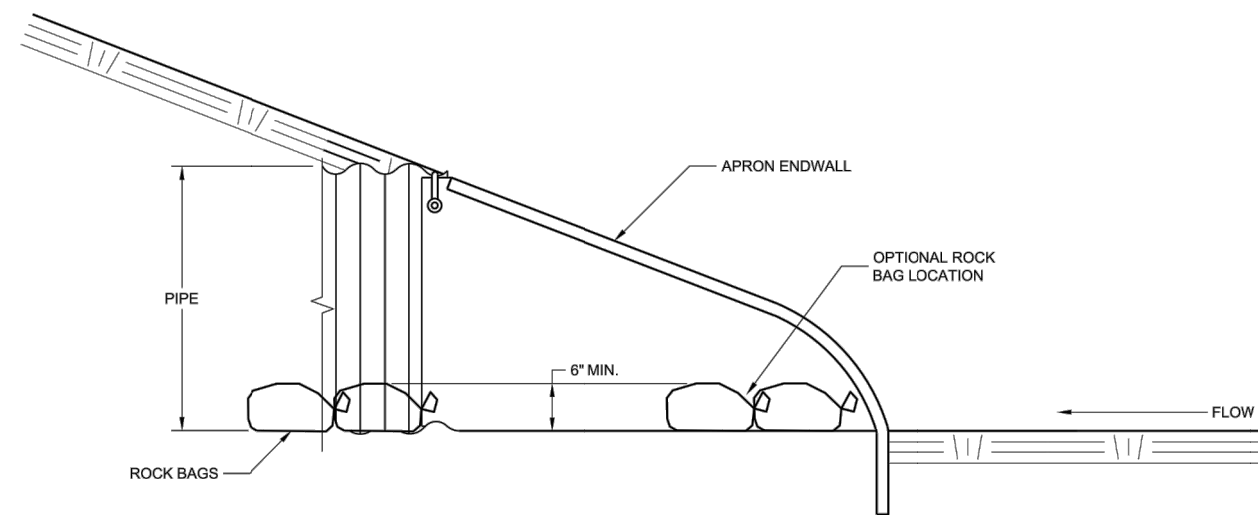

SIDE VIEW

CULVERT PIPE CHECK
(INSTALL ON INLET END ONLY)

PROJECT DATE:	DRAWN BY:	NO.	DATE	REVISION	BY:
	JFK				
	JFK				
	CDG				



ENGINEERING | ARCHITECTURE | SURVEYING
FUNDING | PLANNING | ENVIRONMENTAL
146 North Central Ave, Marshfield WI 54449
(715) 384-2133 www.msa-ps.com
© MSA Professional Services, Inc.

GRANTON SCHOOLS SOUTH PARKING LOT
GRANTON AREA SCHOOL DISTRICT
CLARK COUNTY, WISCONSIN

EROSION CONTROL DETAILS

PROJECT NO.
1486602
SHEET
C004

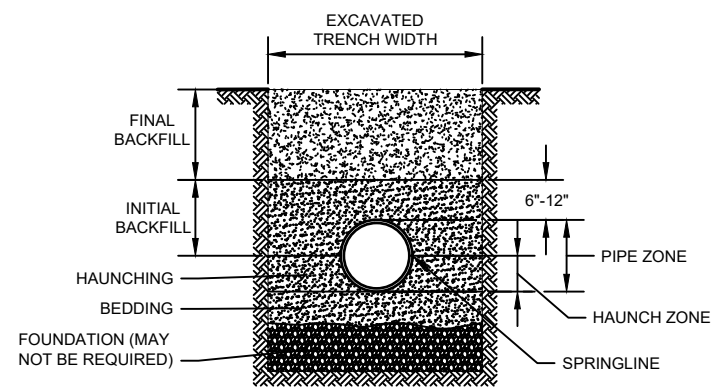

GENERAL NOTES:

1. DETAILS OF CONSTRUCTION NOT SHOWN ON THIS DRAWING SHALL CONFORM TO ASTM D2321.
2. CLASS II EMBEDMENT MATERIAL SHALL BE CLEAN, COARSE-GRAINED SOILS WITH LITTLE TO NO FINES. NO PARTICLES LARGER THAN 1 1/2 -INCHES SHALL BE USED IN THE PIPE EMBEDMENT.
3. WHERE HYDRAULIC GRADIENT EXISTS USE A WELL-GRADED MIXTURE TO MINIMIZE MIGRATION OF FINES FROM ADJACENT SOIL.
4. CLASS II MATERIAL IS SUITABLE AS A FOUNDATION AND FOR REPLACING OVER- EXCAVATED AND UNSTABLE TRENCH BOTTOM. INSTALL AND COMPACT IN 6-INCH MAXIMUM LAYERS.
5. INSTALL AND COMPACT BEDDING IN 6-INCH MAXIMUM LAYERS. LEVEL FINAL GRADE BY HAND. MINIMUM DEPTH 4 INCH (6 INCH IN ROCK CUTS.)
6. INSTALL AND COMPACT HAUNCHING IN 6-INCH MAXIMUM LAYERS. WORK IN AROUND PIPE BY HAND TO PROVIDE UNIFORM SUPPORT.
7. INSTALL AND COMPACT INITIAL BACKFILL TO A MINIMUM OF 6 INCH ABOVE PIPE CROWN.
8. EMBEDMENT COMPACTION:
MINIMUM DENSITY 85% STANDARD PROCTOR. USE HAND TAMPERS OR VIBRATORY COMPACTORS.
10. EMBEDMENT INCLUDES BEDDING, HAUNCHING, AND INITIAL BACKFILL.

CLASS II - FLEXIBLE PIPE EMBEDMENT DETAIL
NO SCALE

TRENCHES SHALL COMPLY WITH OSHA REQUIREMENTS

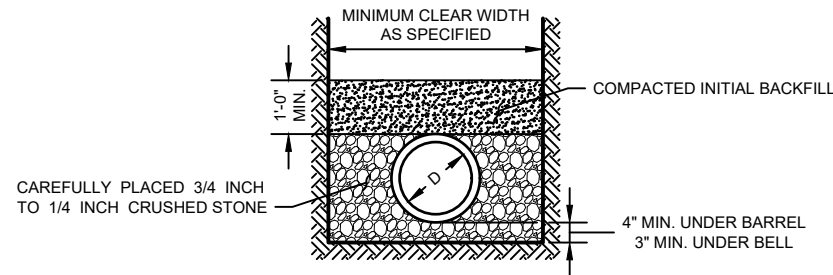

GENERAL NOTES:

1. INITIAL BACKFILL SHALL BE DENSELY COMPACTED, NON-COHESIVE FINELY DIVIDED MATERIAL FREE OF DEBRIS, ORGANIC MATERIAL, AND LARGE STONES.
2. IN ROCK OR OTHER INCOMPRESSIBLE MATERIALS, THE TRENCH SHALL BE OVER EXCAVATED A MINIMUM OF 6-INCHES AND REFILLED WITH GRANULAR MATERIAL.

CRUSHED STONE EMBEDMENT DETAIL
NO SCALE

TRENCHES SHALL COMPLY WITH OSHA REQUIREMENTS

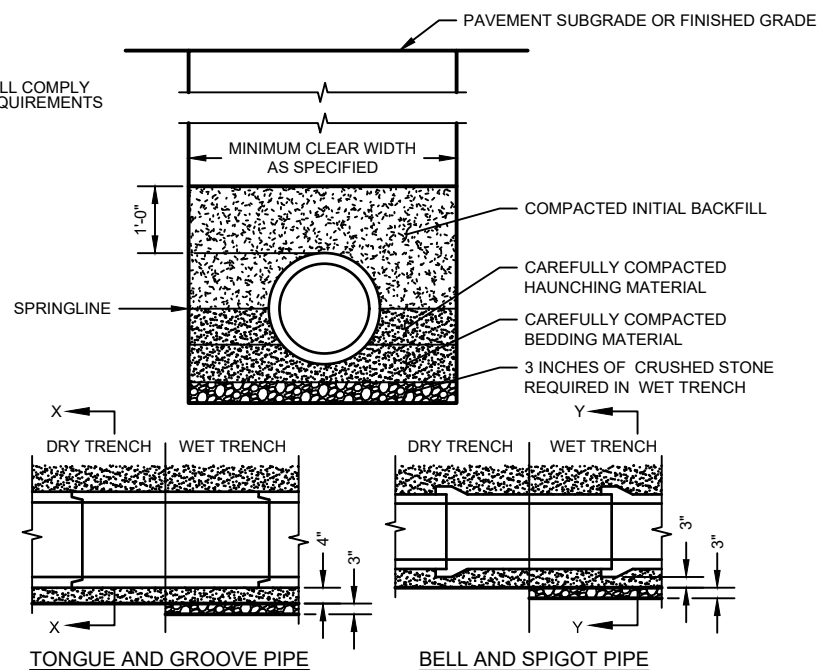

GENERAL NOTES:

1. BEDDING AND HAUNCHING MATERIAL SHALL BE WELL-GRADED 3/4 TO 1/4 INCH CRUSHED STONE OR OTHER NON-COHESIVE MATERIAL NOT SUBJECT TO MIGRATION AND FREE OF DEBRIS, ORGANIC MATERIAL, AND LARGE STONES.
2. BEDDING MATERIAL TO BE PLACED BEFORE SETTING PIPE, 4 INCH MINIMUM UNDER BARREL WITH 3 INCH MINIMUM UNDER BELL.
3. INITIAL BACKFILL SHALL BE DENSELY COMPACTED, NON-COHESIVE FINELY DIVIDED MATERIAL FREE OF DEBRIS, ORGANIC MATERIAL, AND LARGE STONES.
4. IN ROCK OR OTHER UNCOMPRESSIBLE MATERIALS, THE TRENCH SHALL BE OVEREXCAVATED A MINIMUM OF 6-INCHES AND REFILLED WITH GRANULAR MATERIAL.

CLASS "B" EMBEDMENT FOR RIGID PIPE DETAIL
NO SCALE

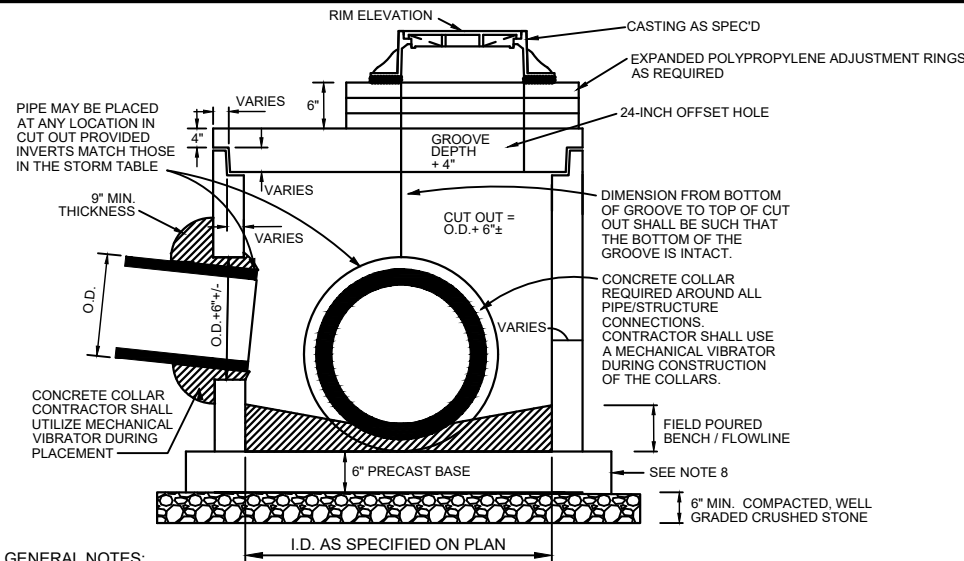

GENERAL NOTES:

1. SEE PLANS FOR SIZE, NUMBER, AND LOCATION OF PIPES.
2. DETAILS OF CONSTRUCTION, MATERIALS AND WORKMANSHIP NOT SHOWN ON THIS DRAWING SHALL CONFORM TO THE PERTINENT REQUIREMENTS OF THE SPECIFICATIONS.
3. DETAILED DRAWINGS FOR PROPOSED ALTERNATE DESIGNS FOR UNDERGROUND DRAINAGE STRUCTURES SHALL BE SUBMITTED TO THE ENGINEER FOR APPROVAL PROVIDING THAT SUCH ALTERNATE DESIGNS MAKE PROVISION FOR EQUIVALENT CAPACITY AND STRENGTH.
4. ALL PRECAST INLET UNITS SHALL CONFORM TO THE PERTINENT REQUIREMENTS OF AASHTO DESIGNATION M 199.
5. PRECAST REINFORCED BASES SHALL BE PLACED ON A BED OF MATERIAL AT LEAST 6 INCHES IN DEPTH, WHICH MEETS THE REQUIREMENTS FOR WELL GRADED CRUSHED STONE. THIS BEDDING SHALL BE COMPACTED AND PROVIDE UNIFORM SUPPORT FOR THE ENTIRE AREA OF THE BASE.
6. ALL BAR STEEL AND WELDED WIRE FABRIC REINFORCEMENT SHALL BE EMBEDDED 2 INCHES CLEAR UNLESS OTHERWISE SHOWN OR NOTED.
7. PRECAST REINFORCED CONCRETE RISERS SHALL BE PLACED WITH TONGUE DOWN.
8. OVERHANGING BASE NOT REQUIRED WHERE INTEGRAL BASE IS ALLOWED. SEE SPECIAL PROCEDURES OR CONTACT ENGINEER TO VERIFY.

STORM MANHOLE DETAIL
NO SCALE

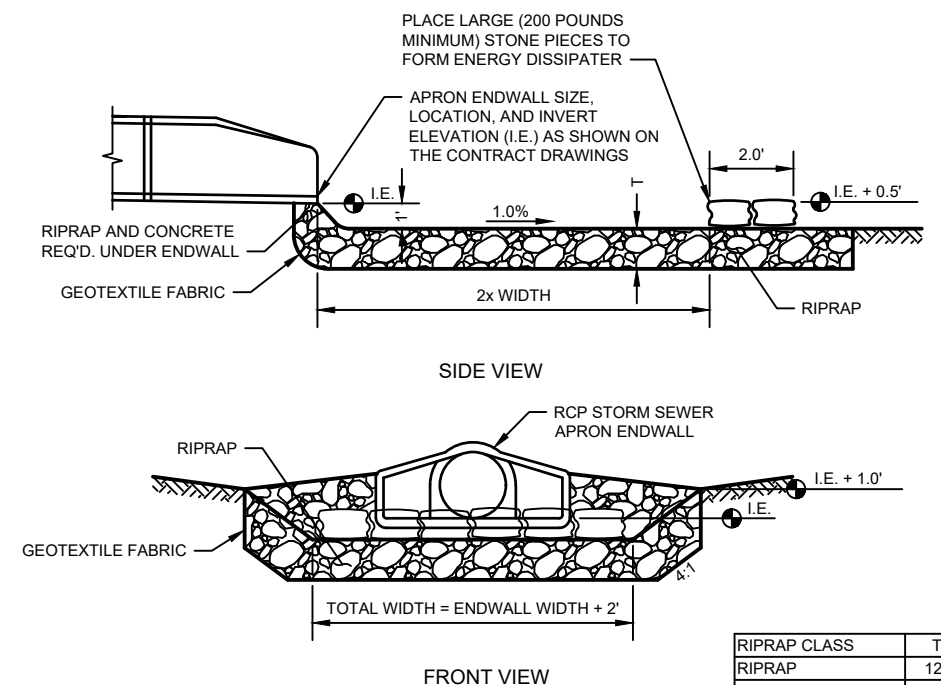

GENERAL NOTES:

1. DETAILS OF CONSTRUCTION, MATERIALS AND WORKMANSHIP NOT SHOWN ON THIS DRAWING SHALL CONFORM TO THE PERTINENT REQUIREMENTS OF THE SPECIFICATIONS.
2. THE RIPRAP CLASS AND GEOTEXTILE FABRIC TYPE SHALL BE AS SHOWN ON THE PLANS AND REQUIRED IN THE SPECIFICATIONS.

STORM SEWER OUTFALL DETAIL
NO SCALE

PROJECT DATE:	NO.	DATE	REVISION	BY:
DRAWN BY: JFK				
DESIGNED BY: JFK				
CHECKED BY: CDG				



ENGINEERING | ARCHITECTURE | SURVEYING
FUNDING | PLANNING | ENVIRONMENTAL
146 North Central Ave, Marshfield WI 54449
(715) 384-2133 www.msa-ps.com
© MSA Professional Services, Inc.

GRANTON SCHOOLS SOUTH PARKING LOT
GRANTON AREA SCHOOL DISTRICT
CLARK COUNTY, WISCONSIN

STORM SEWER DETAILS

PROJECT NO:
1486602
SHEET
C005

NYLOPLAST DRAIN BASIN WITH DOME GRATE

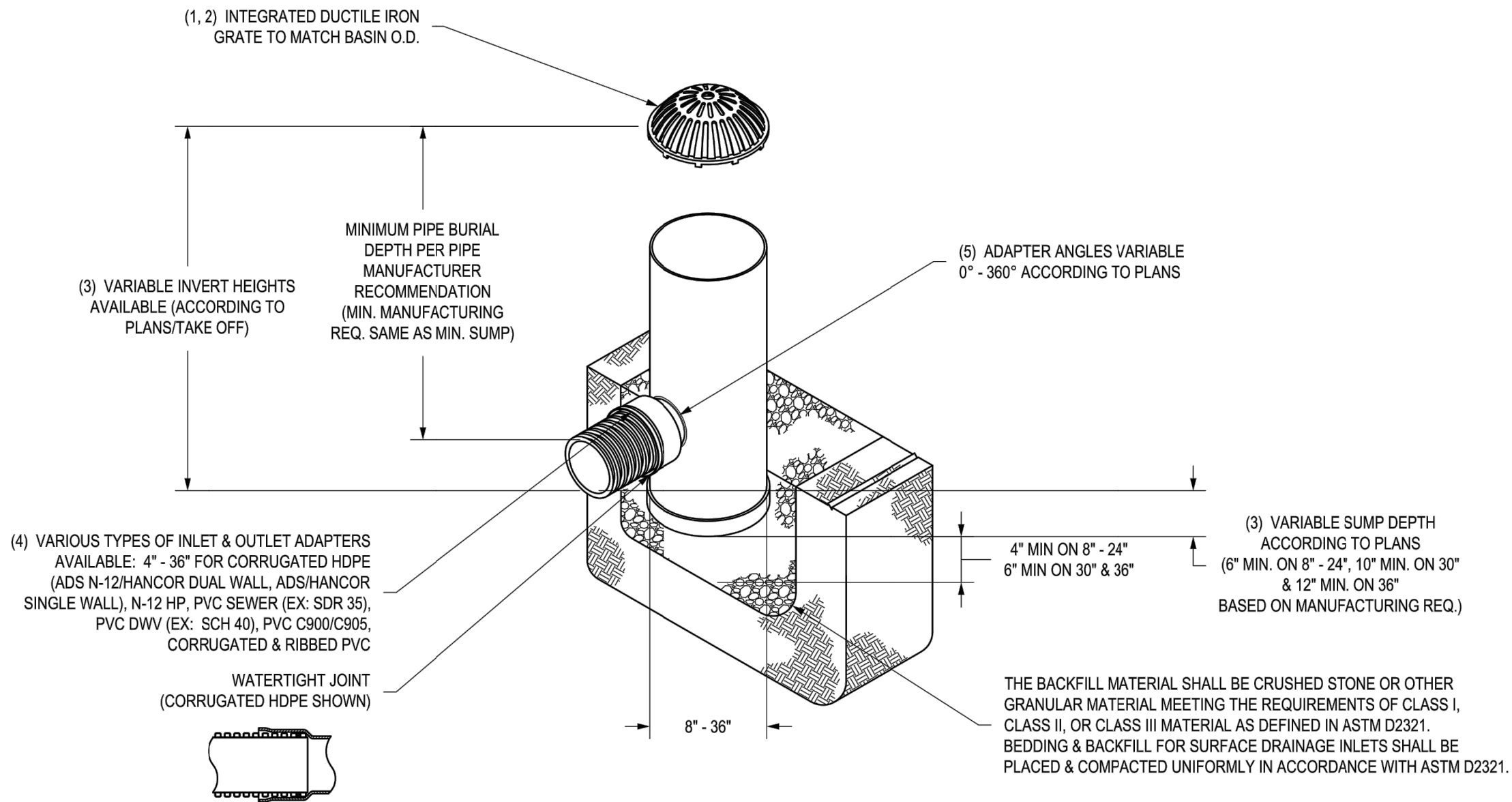

- 1 - 8" - 30" DOME GRATES SHALL BE DUCTILE IRON PER ASTM A536 GRADE 70-50-05.
- 2 - 8" & 10" DOME GRATES FIT ONTO THE DRAIN BASINS WITH THE USE OF A PVC BODY TOP. SEE DRAWING NO. 7001-110-045.
- 3 - DRAIN BASIN TO BE CUSTOM MANUFACTURED ACCORDING TO PLAN DETAILS. RISERS ARE NEEDED FOR BASINS OVER 84" DUE TO SHIPPING RESTRICTIONS. SEE DRAWING NO. 7001-110-065.
- 4 - DRAINAGE CONNECTION STUB JOINT TIGHTNESS SHALL CONFORM TO ASTM D3212 FOR CORRUGATED HDPE (ADS N-12/HANCOR DUAL WALL), N-12 HP, & PVC SEWER (4" - 36").
- 5 - ADAPTERS CAN BE MOUNTED ON ANY ANGLE 0° TO 360°. TO DETERMINE MINIMUM ANGLE BETWEEN ADAPTERS SEE DRAWING NO. 7001-110-012.
- 6 - 8" - 30" DOME GRATES HAVE NO LOAD RATING.

THIS PRINT DISCLOSES SUBJECT MATTER IN WHICH NYLOPLAST HAS PROPRIETARY RIGHTS. THE RECEIPT OR POSSESSION OF THIS PRINT DOES NOT CONFER, TRANSFER, OR LICENSE THE USE OF THE DESIGN OR TECHNICAL INFORMATION SHOWN HEREIN REPRODUCTION OF THIS PRINT OR ANY INFORMATION CONTAINED HEREIN, OR MANUFACTURE OF ANY ARTICLE HEREFROM, FOR THE DISCLOSURE TO OTHERS IS FORBIDDEN, EXCEPT BY SPECIFIC WRITTEN PERMISSION FROM NYLOPLAST. ©2013 NYLOPLAST

DRAWN BY	EBC	MATERIAL	
DATE	03-25-10		
REVISED BY	NMH	PROJECT NO./NAME	
DATE	06-12-18		
DWG SIZE	A	SCALE	1:40 SHEET 1 OF 1

	3130 VERONA AVE BUFORD, GA 30518 PHN (770) 932-2443 FAX (770) 932-2490 www.nyloplast-us.com
	TITLE DRAIN BASIN WITH DOME GRATE QUICK SPEC INSTALLATION DETAIL
DWG NO.	7001-110-397 REV E

NO.	DATE	REVISION	BY
1			
2			
3			
4			
5			
6			



ENGINEERING | ARCHITECTURE | SURVEYING
FUNDING | PLANNING | ENVIRONMENTAL
146 North Central Ave, Marshfield WI 54449
(715) 384-2133 www.msa-ps.com
© MSA Professional Services, Inc.

GRANTON SCHOOLS SOUTH PARKING LOT
GRANTON AREA SCHOOL DISTRICT
CLARK COUNTY, WISCONSIN

STORM SEWER DETAILS

PROJECT NO.
1486602
SHEET
C006

NYLOPLAST DRAIN BASIN WITH STANDARD GRATE

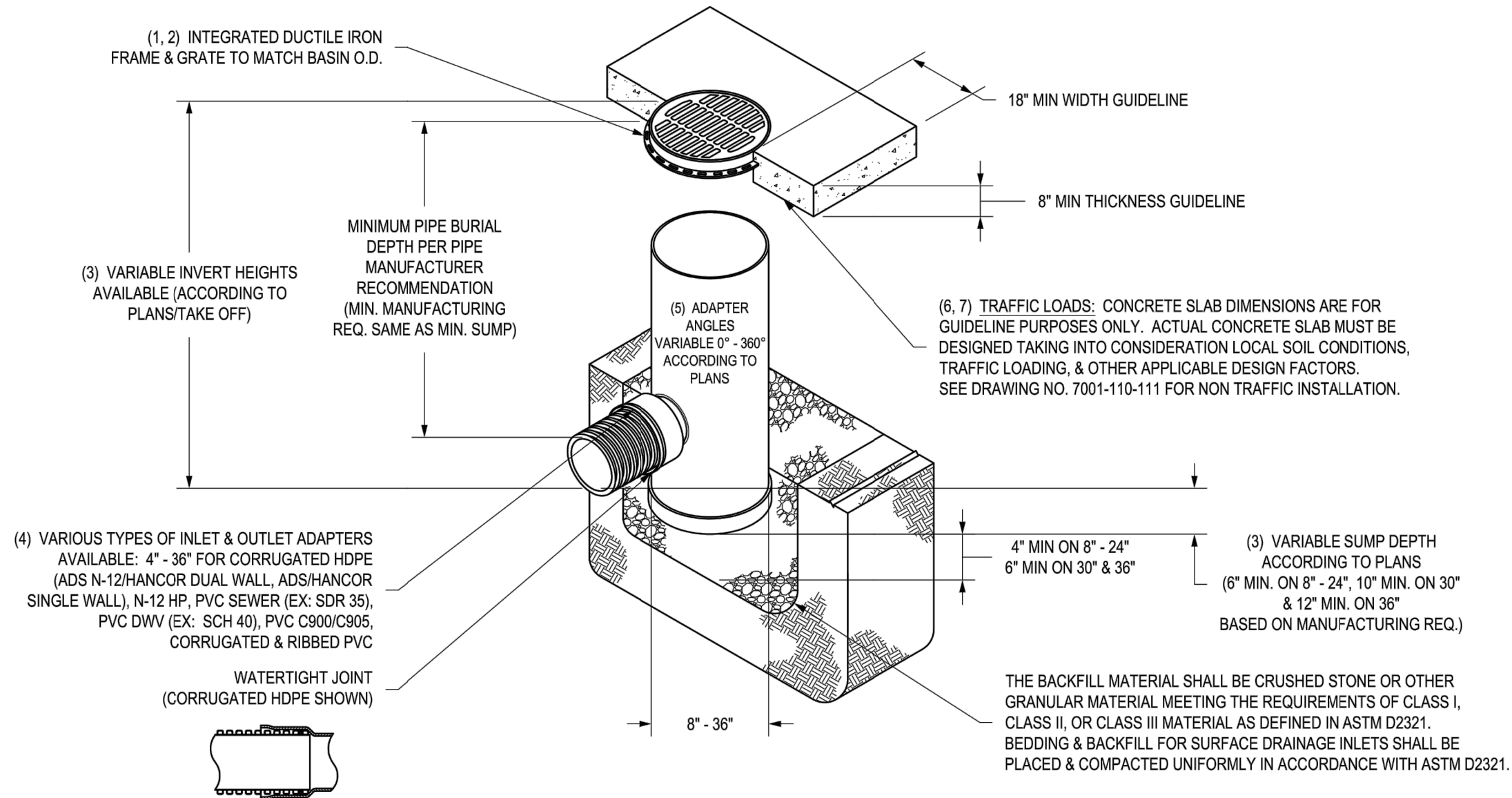

- 1 - 8" - 30" STANDARD GRATES SHALL BE DUCTILE IRON PER ASTM A536 GRADE 70-50-05.
- 2 - 12" - 30" FRAMES SHALL BE DUCTILE IRON PER ASTM A536 GRADE 70-50-05. 8" & 10" STANDARD GRATES FIT DIRECTLY ONTO DRAIN BASINS WITH THE USE OF A PVC BODY TOP. SEE DRAWING NO. 7001-110-045.
- 3 - DRAIN BASIN TO BE CUSTOM MANUFACTURED ACCORDING TO PLAN DETAILS. RISERS ARE NEEDED FOR BASINS OVER 84" DUE TO SHIPPING RESTRICTIONS. SEE DRAWING NO. 7001-110-065.
- 4 - DRAINAGE CONNECTION STUB JOINT TIGHTNESS SHALL CONFORM TO ASTM D3212 FOR CORRUGATED HDPE (ADS N-12/HANCOR DUAL WALL), N-12 HP, & PVC SEWER (4" - 36").
- 5 - ADAPTERS CAN BE MOUNTED ON ANY ANGLE 0° TO 360°. TO DETERMINE MINIMUM ANGLE BETWEEN ADAPTERS SEE DRAWING NO. 7001-110-012.
- 6 - 12" - 30" STANDARD GRATES SHALL MEET H-20 LOAD RATING.
- 7 - 8" & 10" STANDARD GRATES ARE RATED FOR LIGHT DUTY APPLICATIONS ONLY; NO CONCRETE COLLAR NEEDED FOR LIGHT DUTY RATING.

THIS PRINT DISCLOSES SUBJECT MATTER IN WHICH NYLOPLAST HAS PROPRIETARY RIGHTS. THE RECEIPT OR POSSESSION OF THIS PRINT DOES NOT CONFER, TRANSFER, OR LICENSE THE USE OF THE DESIGN OR TECHNICAL INFORMATION SHOWN HEREIN REPRODUCTION OF THIS PRINT OR ANY INFORMATION CONTAINED HEREIN, OR MANUFACTURE OF ANY ARTICLE HEREFROM, FOR THE DISCLOSURE TO OTHERS IS FORBIDDEN, EXCEPT BY SPECIFIC WRITTEN PERMISSION FROM NYLOPLAST. ©2011 NYLOPLAST

DRAWN BY	EBC	MATERIAL	 3130 VERONA AVE BUFORD, GA 30518 PHN (770) 932-2443 FAX (770) 932-2490 www.nyloplast-us.com
DATE	1-23-06		
REVISED BY	NMH	PROJECT NO./NAME	TITLE DRAIN BASIN WITH STANDARD GRATE QUICK SPEC INSTALLATION DETAIL
DATE	06-12-18		
DWG SIZE	A	SCALE 1:40 SHEET 1 OF 1	DWG NO. 7001-110-144 REV J

PROJECT DATE:	DRAWN BY:	NO.	DATE	REVISION	BY:
	JFK				
	JFK				
	CDG				

PLOT DATE: 4/29/2022 4:06 PM, G:\1414866\1486602\CADD\Construction Documents\PLAN PRODUCTION DRAWINGS\GENERALS AND DETAILS.dwg

ENGINEERING | ARCHITECTURE | SURVEYING
 FUNDING | PLANNING | ENVIRONMENTAL
 146 North Central Ave, Marshfield WI 54449
 (715) 384-2133 www.msa-ps.com
© MSA Professional Services, Inc.

GRANTON SCHOOLS SOUTH PARKING LOT
GRANTON AREA SCHOOL DISTRICT
CLARK COUNTY, WISCONSIN

STORM SEWER DETAILS

PROJECT NO.
1486602
SHEET
C007

GENERAL NOTES (THIS SHEET)

DETAILS OF CONSTRUCTION, MATERIALS, AND WORKMANSHIP NOT SHOWN ON THIS DRAWING SHALL CONFORM TO THE PERTINENT REQUIREMENTS OF THE CONTRACT.

TOP SURFACES OF CONCRETE BASES SHALL BE TROWEL FINISHED SMOOTH AND LEVEL.

CONDUIT SIZES AND LOCATIONS SHALL BE AS SHOWN ON THE PLANS.

MINIMUM BENDING RADIUS OF CONDUIT IS EQUAL TO 6 TIMES THE DIAMETER.

CONDUIT HEIGHT ABOVE CONCRETE BASES SHALL BE 1 INCH.

ALL CONDUIT ENDS AT THE TOP OF CONCRETE BASES SHALL BE CAPPED IMMEDIATELY AFTER PLACEMENT AND BEFORE CONCRETE IS POURED. CONDUITS IN WHICH WIRE OR CABLE IS NOT INSTALLED SHALL REMAIN CAPPED.

IF A BASE REQUIRES A DEEP FORM BECAUSE OF LOOSE DIRT OR FILL, THE FORM SHALL BE REMOVED BEFORE BACKFILLING AROUND THE BASE. BACKFILL SHALL BE TAMPED TIGHT AGAINST THE BARE CONCRETE BASE IN LAYERS OF 1 FOOT OR LESS.

A NO. 4 AWG STRANDED COPPER EQUIPMENT GROUNDING CONDUCTOR SHALL BE EXOTHERMICALLY WELDED TO THE EQUIPMENT GROUNDING ELECTRODE (GROUND ROD).

THE EQUIPMENT GROUNDING CONDUCTOR SHALL ENTER THE BASE THROUGH A 1 INCH CONDUIT INSTALLED FOR GROUNDING PURPOSES, LEAVING A 4 FOOT COIL OF WIRE ABOVE THE CONCRETE BASE. THE EQUIPMENT GROUNDING CONDUCTOR SHALL BE NEATLY COILED AND THE COILS TIED TOGETHER.

ANCHOR RODS SHALL BE 1" X 36".

ANCHOR RODS SHALL BE THREADED 12" IN LENGTH ON EACH END OF THE ROD. ANCHOR RODS SHALL BE MANUFACTURED IN ACCORDANCE WITH ASTM A-449 OR ASTM A-687 (GRADE 105).

WHEN ANCHOR RODS USING THE "L" BEND ARE FURNISHED, THE 4" "L" BEND SHALL BE IN ADDITION TO THE SPECIFIED ANCHOR ROD BAR LENGTH. THE "L" BEND END SHALL NOT BE THREADED.

WELDING OF THE ANCHOR RODS TO THE CAGE IS UNACCEPTABLE. THE WIRES SHALL BE USED.

ANCHOR RODS SHALL BE INSTALLED WITH MISALIGNMENTS OF LESS THAN 1:40 FROM VERTICAL PER SECTION 5.17.6.3, AASHTO 2001 4TH EDITION STANDARD SPECIFICATIONS FOR STRUCTURAL SUPPORTS FOR HIGHWAY SIGNS, LUMINAIRES, AND TRAFFIC SIGNALS.

BAR STEEL REINFORCEMENT SHALL BE COATED WITH POWDERED EPOXY RESIN

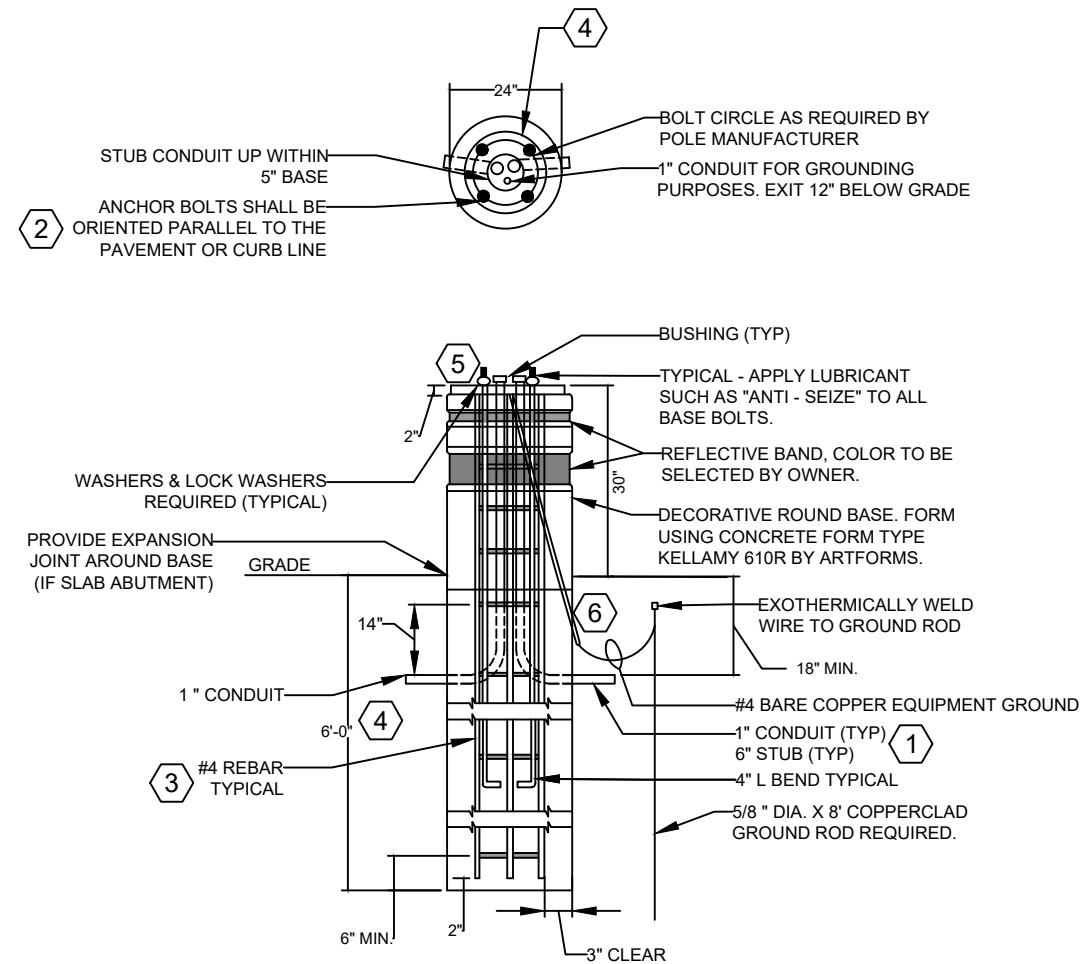

CONCRETE BASE FOR POLE TYPE "P2"

SCALE: NONE

KEYNOTES (THIS SHEET):

1. THE MINIMUM DEPTH OF CONDUIT EXITING THE CONCRETE BASE SHALL BE 18 INCHES. THE MAXIMUM DEPTH OF ALL CONDUIT SHALL BE 36 INCHES EXCEPT WITH WRITTEN APPROVAL BY THE ENGINEER.
2. (4) 1" DIA. X 36" ANCHOR RODS
3. (6) NO. 4 X 6'-8" BAR STEEL REINFORCEMENT.
4. (7) NO. 4 X 6'-2" BAR STEEL REINFORCEMENT @ 1'-0" C-C.
5. ANY ANCHOR ROD PROJECTION SHORTER THAN 2-3/4" OR LONGER THAN 3-1/4" SHALL REQUIRE THE BASE TO BE REMOVED AND REPLACED AT THE CONTRACTOR'S EXPENSE.
6. BASES SHALL BE EXCAVATED BY USE OF A CIRCULAR AUGER. TOP OF THE BASE SHALL BE FORMED DOWN TO 12 INCHES BELOW GRADE WITH ROUND COLUMN FOR SUCH AS SONOTUBE, EZYTUBE, OR EASY-POUR.

PROJECT GENERAL NOTES

- A. ALL ELECTRICAL WORK SHALL BE DONE UNDER THE DIRECTION OF A CURRENTLY CERTIFIED LICENSED STATE OF WISCONSIN MASTER ELECTRICIAN.

PROJECT DATE:	DRAWN BY:	NO.	DATE	REVISION	BY:
	JFK	-	-	-	-
	JFK	-	-	-	-
	CDG	-	-	-	-



ENGINEERING | ARCHITECTURE | SURVEYING
FUNDING | PLANNING | ENVIRONMENTAL
146 North Central Ave, Marshfield WI 54449
(715) 384-2133 www.msa-ps.com
© MSA Professional Services, Inc.

GRANTON SCHOOLS SOUTH PARKING LOT
GRANTON AREA SCHOOL DISTRICT
CLARK COUNTY, WISCONSIN

SITE DETAILS

PROJECT NO.
1486602
SHEET
C008

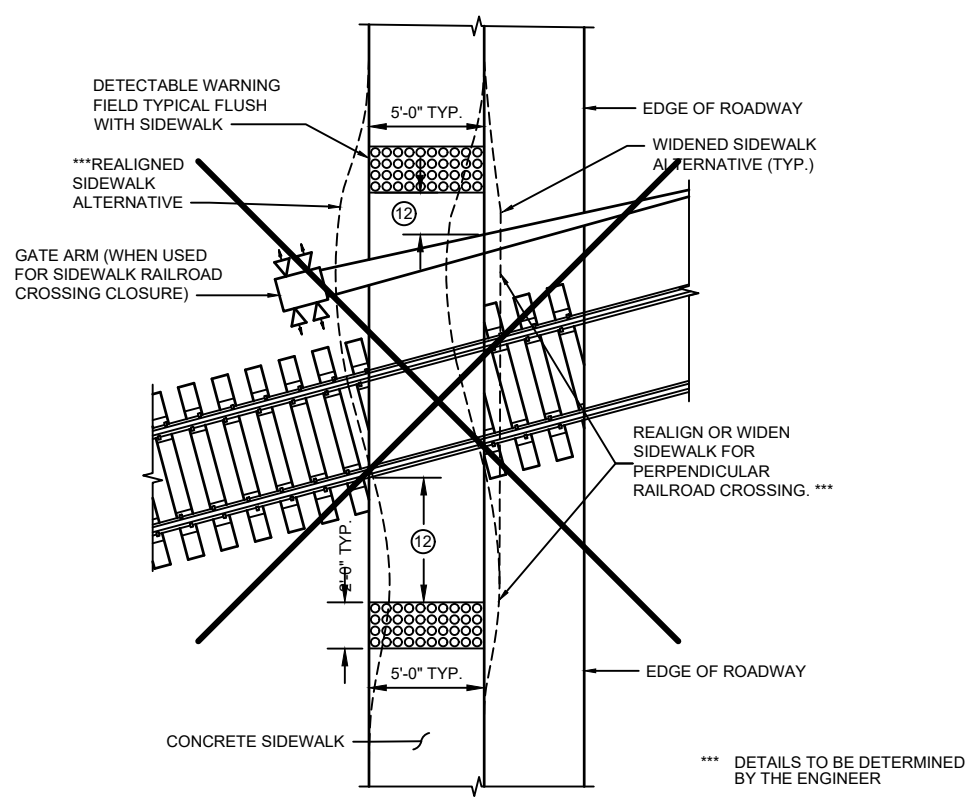

CURB RAMP TYPE 8
DETECTABLE WARNINGS AT RAILROAD CROSSING

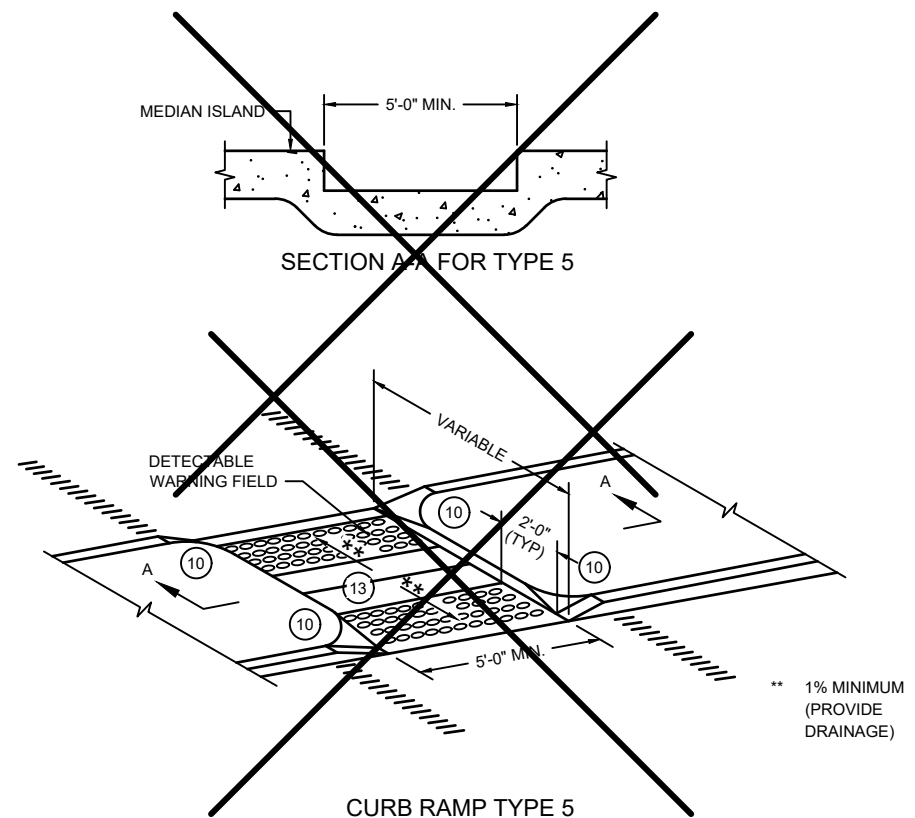

CURB RAMP TYPE 5
MEDIAN ISLAND NON-ELEVATED PEDESTRIAN CROSSING

GENERAL NOTES

- AVOID PLACING DRAINAGE STRUCTURES, JUNCTION BOXES OR OTHER OBSTRUCTIONS IN FRONT OF RAMP ACCESS AREAS.
- DETAILS OF CONSTRUCTION, MATERIALS AND WORKMANSHIP NOT SHOWN ON THIS DRAWING SHALL CONFORM TO THE PERTINENT REQUIREMENTS OF THE STANDARD SPECIFICATIONS AND THE APPLICABLE SPECIAL PROVISIONS
- SIDEWALK CROSS SLOPE SHALL NOT EXCEED 2%.
- DETECTABLE WARNING FIELDS THAT ARE INSTALLED AS A GROUP OR SIDE BY SIDE, SHALL BE FROM THE SAME MANUFACTURER.
- GRADE CHANGE BETWEEN GUTTER FLAG SLOPE AND THE CURB RAMP SLOPE SHALL NOT EXCEED 11%. MAXIMUM GUTTER FLAG SLOPE IS 4%. PROVIDE LONGITUDINAL DRAINAGE AROUND CURB AND AWAY FROM CURB RAMP. NO VERTICAL LIPS OR DISCONTINUITIES GREATER THAN 1/4 INCH ARE ALLOWED. SLOPE OF CURB HEAD OPENING SHALL MATCH THE RAMP SLOPE, MINIMALLY 1.5% AND NOT TO EXCEED 7%. WHEN ADJACENT TO 1.5% LANDING, CONSTRUCT CURB HEAD OPENING AT 1.5% IN THE DIRECTION OF PEDESTRIAN TRAVEL.
 - AN 8.33% CURB RAMP SLOPE IS ALLOWABLE WITH FLATTENED GUTTER FLAG SLOPE AND NOT TO EXCEED 11% GRADE CHANGE.
 - +/-0.5% CONSTRUCTION TOLERANCE IN SIDEWALK CROSS SLOPE. THE SIDEWALK CROSS SLOPE SHALL NOT EXCEED 2% WITHOUT PRIOR APPROVAL FROM THE ENGINEER.
 - PROVIDE A LEVEL LANDING (MAXIMUM 2% SLOPE) IN ANY DIRECTION OF PEDESTRIAN TRAVEL. STANDARD LANDING SIZE IS 5 FEET BY 5 FEET.
 - INSTALL TRANSITION NOSE. (INCIDENTAL TO OTHER PAY ITEMS). DO NOT MARK TRANSITION NOSE.
 - SLOPE SIDEWALK TOWARD LANDING AS SHOWN WHERE THERE IS NO TERRACE OR WHERE THE TERRACE WIDTH IS LESS THAN 6 FEET WIDE.
 - THE EDGE OF THE DETECTABLE WARNING FIELD NEAREST TO A RAILROAD CROSSING SHALL BE 1.5 FEET +/- 0.1' FROM THE FACE OF THE GATE ARM IF THE GATE ARM EXTENDS ACROSS THE SIDEWALK. WHERE THERE IS NO PEDESTRIAN GATE, THE EDGE OF THE DETECTABLE WARNING FIELD NEAREST TO THE RAILROAD CROSSING SHALL BE 15 FEET FROM THE NEAREST RAIL.
 - DO NOT INSTALL DETECTABLE WARNING FIELDS AT THE EDGES OF STREET-LEVEL PEDESTRIAN REFUGE ISLANDS IF A MINIMUM 2-FOOT CONCRETE SURFACE WITHOUT DETECTABLE WARNINGS (MEASURED IN THE DIRECTION OF PEDESTRIAN TRAVEL) CANNOT BE ACHIEVED.

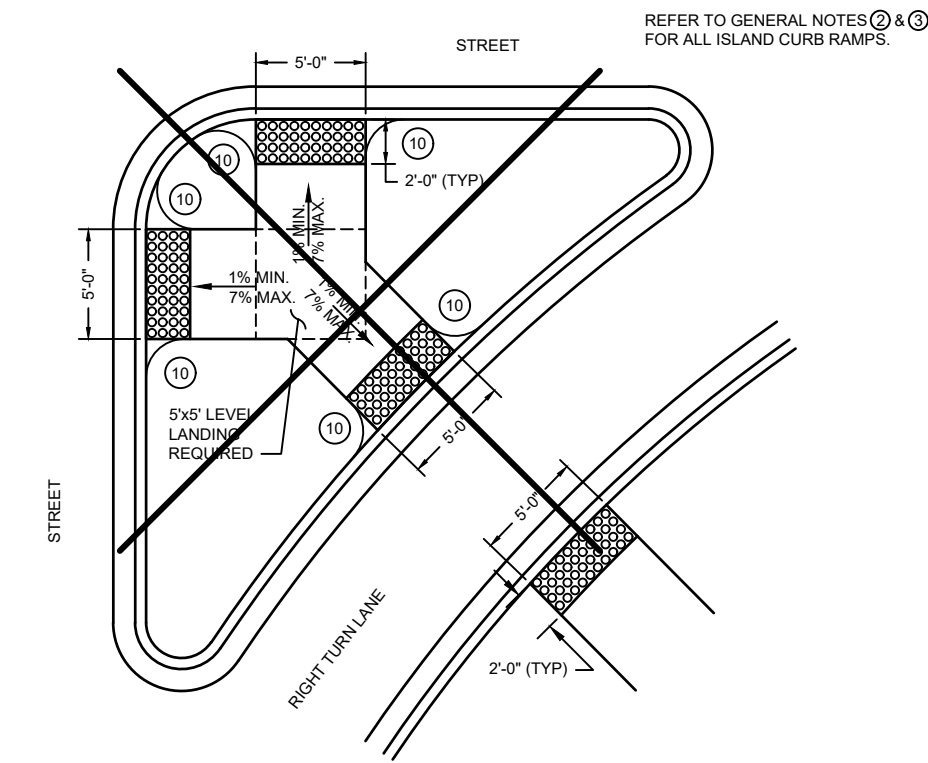

CURB RAMP TYPE 6
DETECTABLE WARNING AT ISLANDS

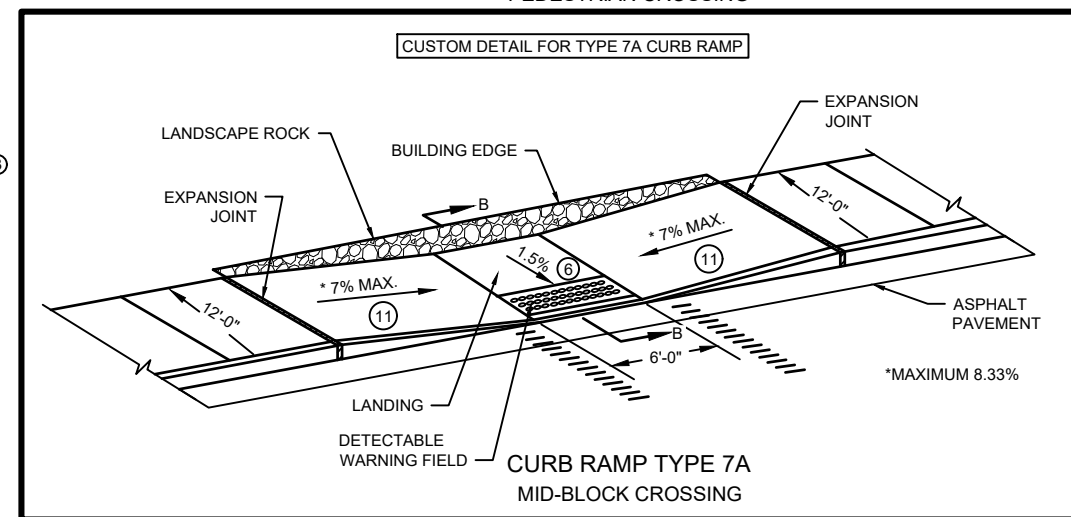

CURB RAMP TYPE 7A
MID-BLOCK CROSSING

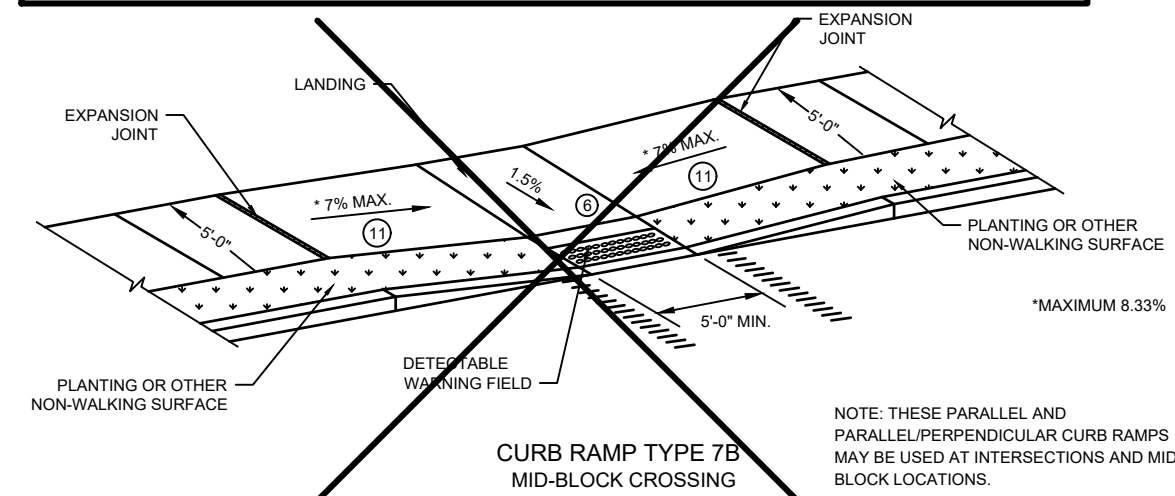

CURB RAMP TYPE 7B
MID-BLOCK CROSSING

NOTE: THESE PARALLEL AND PARALLEL/PERPENDICULAR CURB RAMPS MAY BE USED AT INTERSECTIONS AND MID BLOCK LOCATIONS.

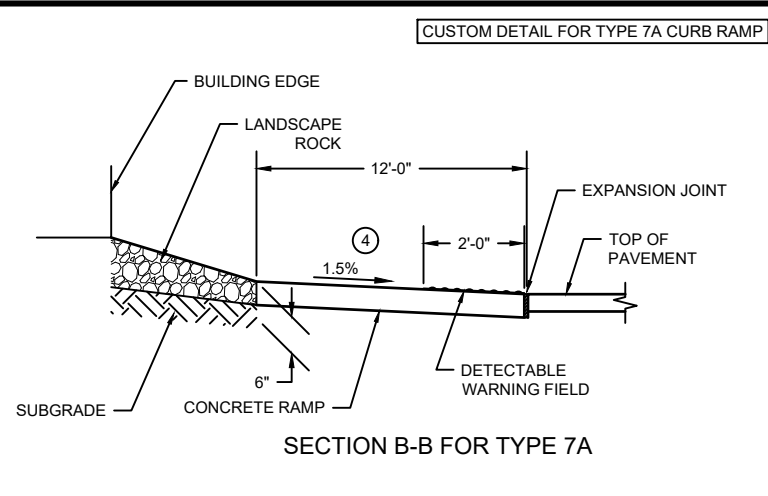
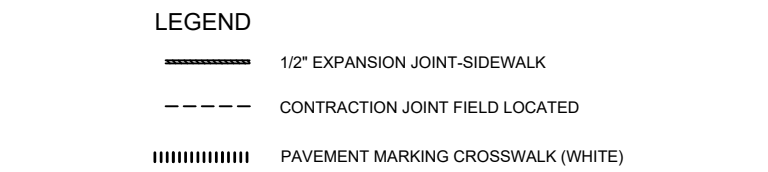

SECTION B-B FOR TYPE 7A

PROJECT DATE:	DRAWN BY:	NO.	DATE	REVISION	BY:
4/29/2022 4:06 PM, G:\1414866\1486602\CADD\Construction Documents\PLAN PRODUCTION DRAWINGS\GENERALS AND DETAILS.dwg	JFK				
	DESIGNED BY: JFK				
	CHECKED BY: CDG				

MSA ENGINEERING | ARCHITECTURE | SURVEYING
FUNDING | PLANNING | ENVIRONMENTAL
146 North Central Ave, Marshfield WI 54449
(715) 384-2133 www.msa-ps.com
© MSA Professional Services, Inc.

GRANTON SCHOOLS SOUTH PARKING LOT
GRANTON AREA SCHOOL DISTRICT
CLARK COUNTY, WISCONSIN

SITE DETAILS

PROJECT NO:
1486602
SHEET
C009

URBAN AREA

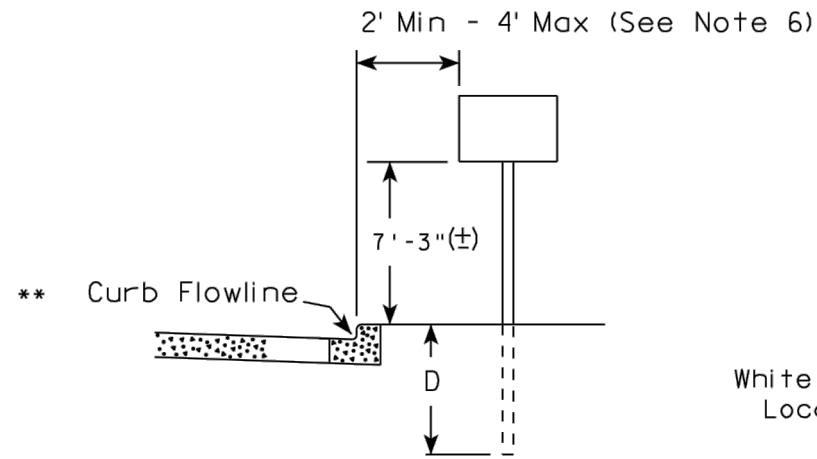

RURAL AREA (See Note 2)

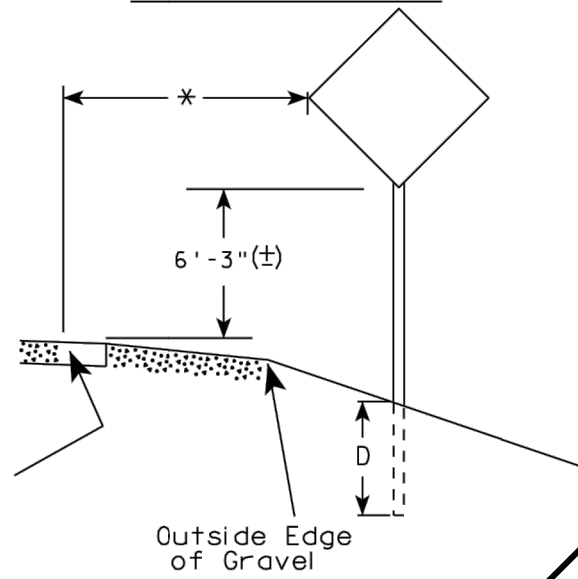

GENERAL NOTES

1. Signs wider than 4 feet or 20 sq.ft or larger, shall be mounted on multiple posts. Refer to plate A4-4.
2. If signs are mounted on barrier wall, see A4-10 sign plate.
3. For expressways and freeways, mounting height is 7'- 3" (±) or 6'-3" (±) depending upon existence of a sub-sign.
4. J-Assemblies are considered to be one sign for mounting height.
5. Minimum mounting height for signs mounted on traffic signal poles is 5'- 3" (±).
6. Offset distance shall be consistent with existing signs or consistent throughout length of project.
7. The (±) tolerance for mounting height is 3 inches.
8. Folding signs shall be mounted at a height of 5'-3" (±) or as directed by the Engineer.
9. The Double Arrow sign (W12-1) shall be mounted at a height of 2'-3" (±). The Chevron sign (W1-8), Roundabout Chevron panel (R6-4B), Enhanced Reference Markers, Clearance Markers (W5-52), Mile Markers (D10 series), In Road Object Markers (W5-54) & End of Road Markers (W5-56) shall be mounted at a height of 4'-3" (±).

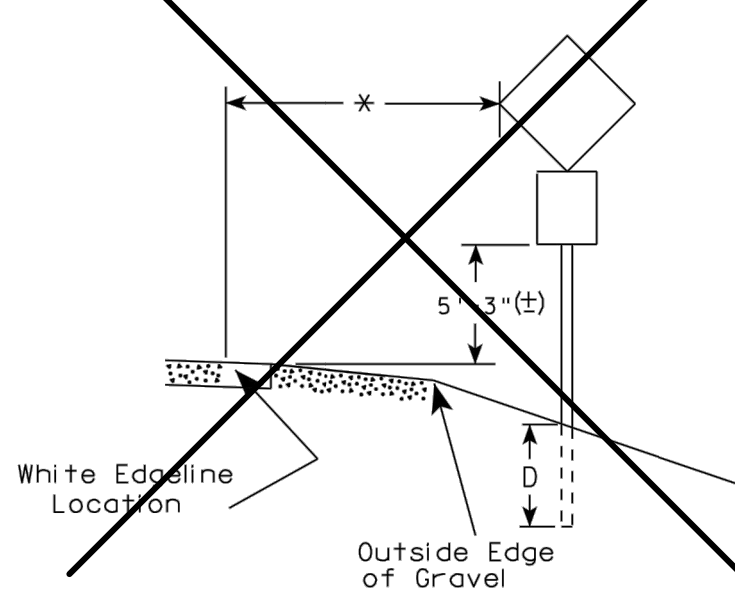
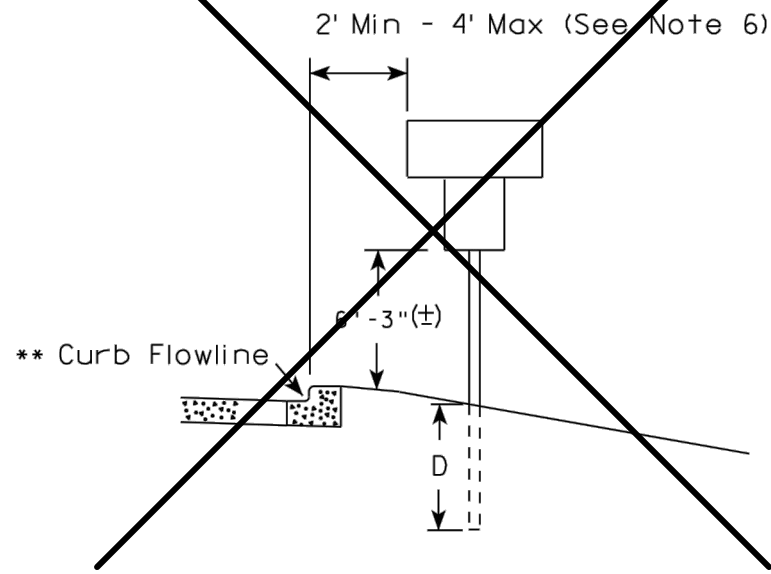

POST EMBEDMENT DEPTH

Area of Sign Installation (Sq. Ft.)	D (Min)
20 or Less	4'
Greater than 20	5'

** The existence of curb and gutter does not in itself mandate the vertical clearance illustrated. That height is typically measured where there is sidewalk adjacent to the roadway or parking is permitted. In the absence of sidewalk vertical clearance is measured from the top of the curb. Offset of signs is measured from the flow line.

* 6 feet from edge of a paved shoulder or 12 feet from the edge of pavement (edge line location) or 2 feet from outside edge of gravel, whichever is greater unless directed by project engineer.

TYPICAL INSTALLATION OF PERMANENT TYPE II SIGNS ON SINGLE POSTS

WISCONSIN DEPT OF TRANSPORTATION
 APPROVED *Matthew R. Rauch*
 For State Traffic Engineer
 DATE 8/21/17 PLATE NO. A4-3.21

PROJECT NO: _____ HWY: _____ COUNTY: _____ SHEET NO: **E**

FILE NAME : C:\CAEfiles\Projects\tr_std\plate\A43.DGN PLOT DATE : 21-AUG-2017 16:04 PLOT BY : **...plotuser...** PLOT NAME : PLOT SCALE : 100.601251:1.000000 WISDOT/CADDS SHEET 42

PROJECT DATE:	DRAWN BY:	NO.	DATE	REVISION	BY:
	JFK				
	JFK				
	CDG				

MSA ENGINEERING | ARCHITECTURE | SURVEYING
 FUNDING | PLANNING | ENVIRONMENTAL
 146 North Central Ave, Marshfield WI 54449
 (715) 384-2133 www.msa-ps.com
 © MSA Professional Services, Inc.

GRANTON SCHOOLS SOUTH PARKING LOT
 GRANTON AREA SCHOOL DISTRICT
 CLARK COUNTY, WISCONSIN

SITE DETAILS

PROJECT NO:
1486602
SHEET
C010

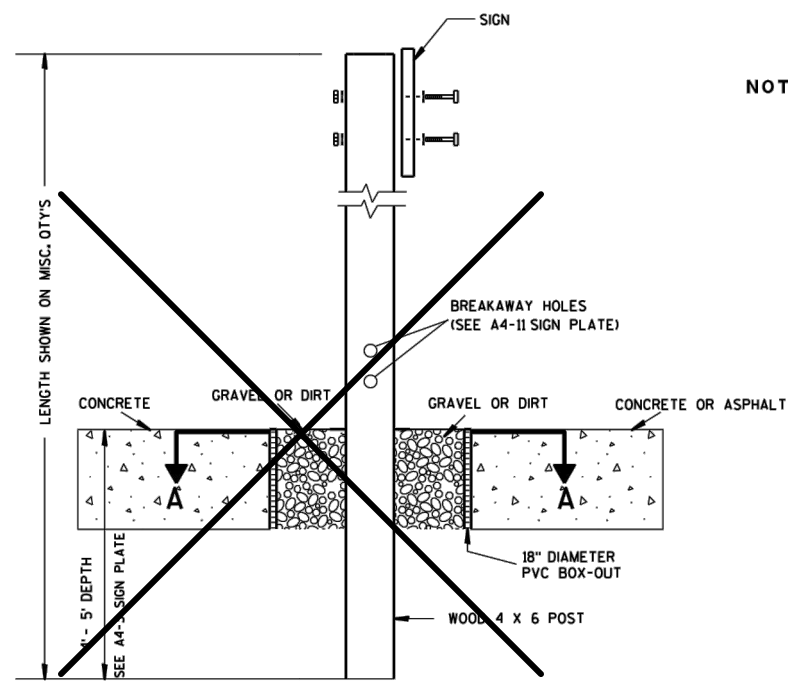

ELEVATION VIEW

DETAIL OF WOOD 4 X 6 SIGN POST IN BOX-OUT

- NOTES:**
1. ALL MATERIAL TO BE APPROVED BY ENGINEER PRIOR TO INSTALLATION
 2. SEE SIGN PLATE A4-8 FOR SIGN HARDWARE REQUIREMENTS
 3. 18 INCH X 18 INCH SQUARE BOX-OUTS MAY BE USED FOR INSTALLATIONS IN EXISTING CONCRETE OR ASPHALT LOCATIONS.

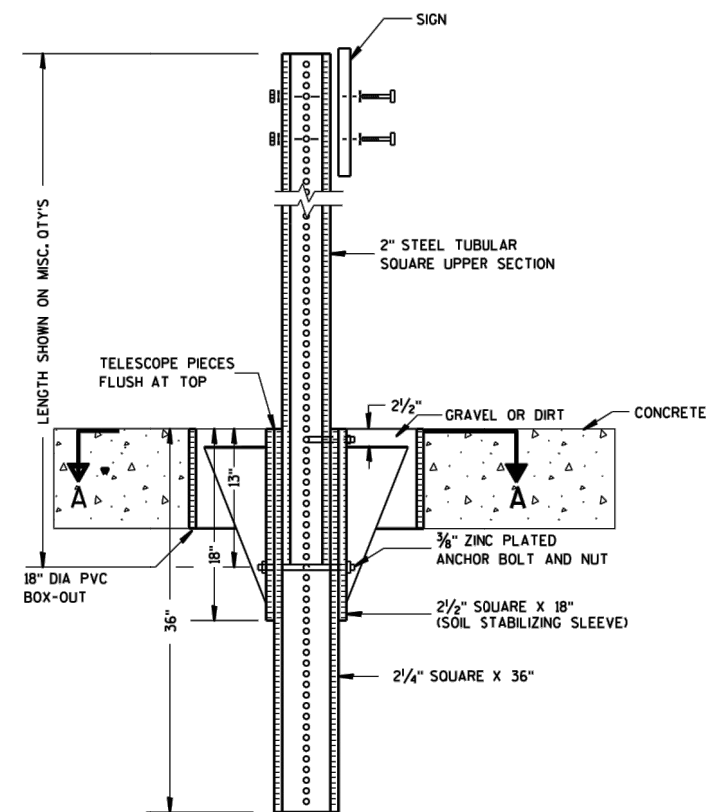

ELEVATION VIEW

DETAIL OF STEEL 2 X 2 SIGN POST IN BOX-OUT

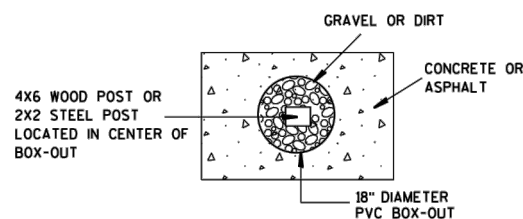

PLAN VIEW

FOR NEW CONCRETE/ASPHALT INSTALLATIONS

**SIGN POST
BOX-OUTS
A4-3B**

WISCONSIN DEPT OF TRANSPORTATION

APPROVED *Matthew R. Rauch*
For State Traffic Engineer

DATE 1/27/14 PLATE NO. A4-3B.1

PROJECT NO:	HWY:	COUNTY:	SHEET NO: E
-------------	------	---------	--------------------

FILE NAME : C:\CAEFiles\Projects\tr_stdp\late\A43B.DGN PLOT DATE : 27-JAN-2014 09:48 PLOT BY : mscsja PLOT NAME : PLOT SCALE : 13.659812:1.000000 WISDOT/CADDS SHEET 42

NO.	DATE	REVISION	BY
1			
2			
3			

PROJECT DATE:
 DRAWN BY: JFK
 DESIGNED BY: JFK
 CHECKED BY: CDG

MSA ENGINEERING | ARCHITECTURE | SURVEYING
 FUNDING | PLANNING | ENVIRONMENTAL
 146 North Central Ave, Marshfield WI 54449
 (715) 384-2133 www.msa-ps.com
© MSA Professional Services, Inc.

GRANTON SCHOOLS SOUTH PARKING LOT
 GRANTON AREA SCHOOL DISTRICT
 CLARK COUNTY, WISCONSIN

SITE DETAILS

PROJECT NO:
1486602
SHEET
C011

**TELESCOPIC TUBING ANCHORS
TWO PIECE SYSTEM**

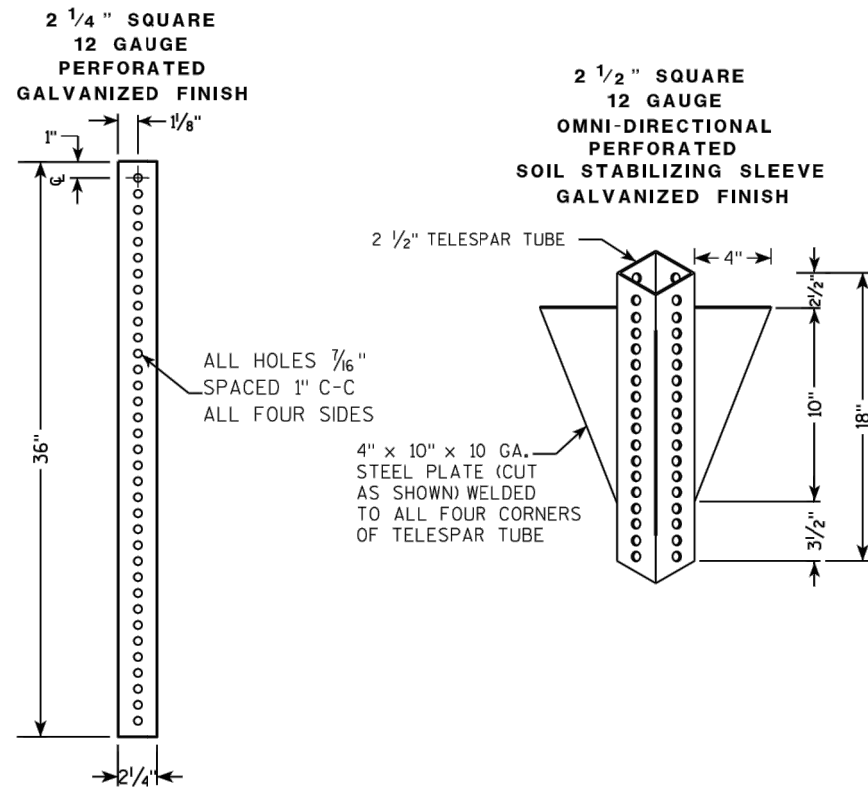

**DETAIL OF TUBULAR STEEL SIGN POST
(IN POURED CONCRETE OR ASPHALT)**

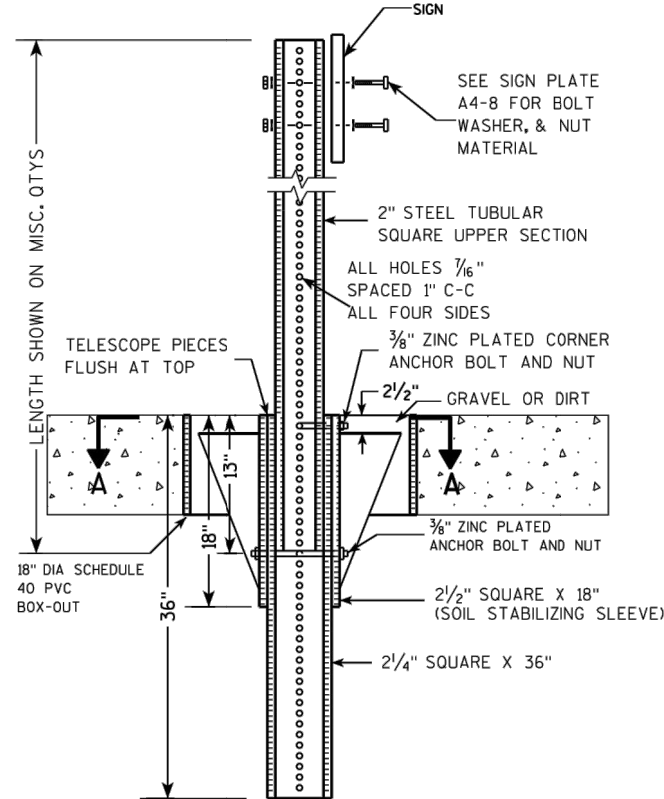

**DETAIL OF TUBULAR STEEL SIGN POST
(IN LOCATIONS OTHER THAN POURED CONCRETE OR ASPHALT)**

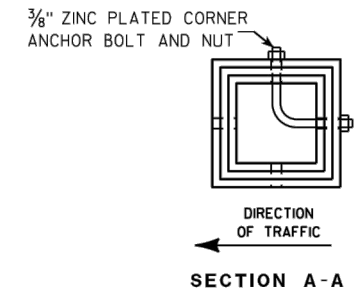
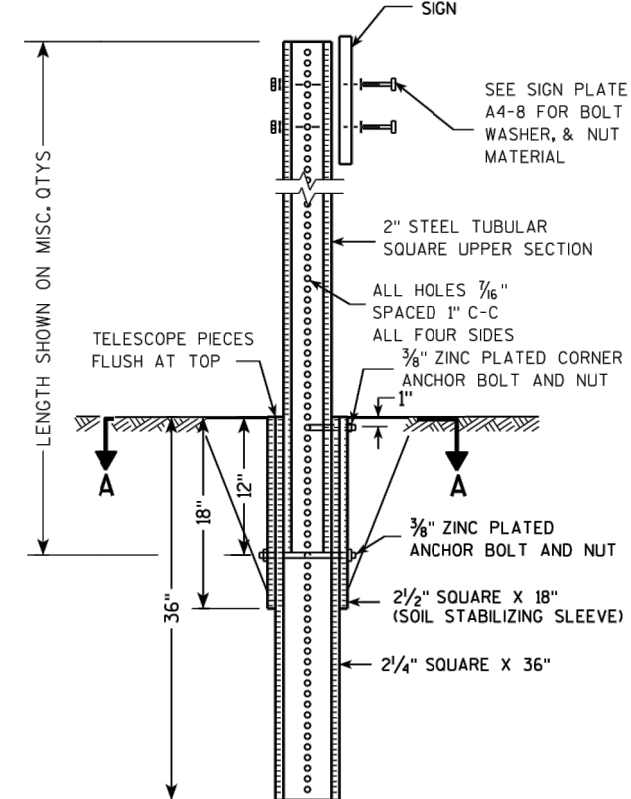

Area of Sign Installation (Sq. Ft.)	Number of Required Posts
9 or less	1
Greater than 9 less than or equal to 18	2
Greater than 18 less than or equal to 27	3

Signs wider than 3 feet or larger than 9 sq. ft shall be mounted on multiple posts (see above table).

**TUBULAR STEEL
SIGN POST
A4-9**

WISCONSIN DEPT OF TRANSPORTATION

APPROVED *Matthew R. Rauch*
for State Traffic Engineer

DATE 2/05/15 PLATE NO. A4-9.9

PROJECT NO: _____ HWY: _____ COUNTY: _____ SHEET NO: **E**

FILE NAME : C:\CAEFiles\Projects\tr_stdplate\A49.DGN

PLOT DATE : 05-FEB-2015 17:09

PLOT BY : mscsja

PLOT NAME :

PLOT SCALE : 13.659812:1.000000

WISDOT/CADDs SHEET 42

NO.	DATE	REVISION	BY
1			
2			
3			

PROJECT DATE: _____
DRAWN BY: JFK
DESIGNED BY: JFK
CHECKED BY: CDG



ENGINEERING | ARCHITECTURE | SURVEYING
FUNDING | PLANNING | ENVIRONMENTAL
146 North Central Ave, Marshfield WI 54449
(715) 384-2133 www.msa-ps.com
© MSA Professional Services, Inc.

GRANTON SCHOOLS SOUTH PARKING LOT
GRANTON AREA SCHOOL DISTRICT
CLARK COUNTY, WISCONSIN

SITE DETAILS

PROJECT NO:
1486602
SHEET
C012

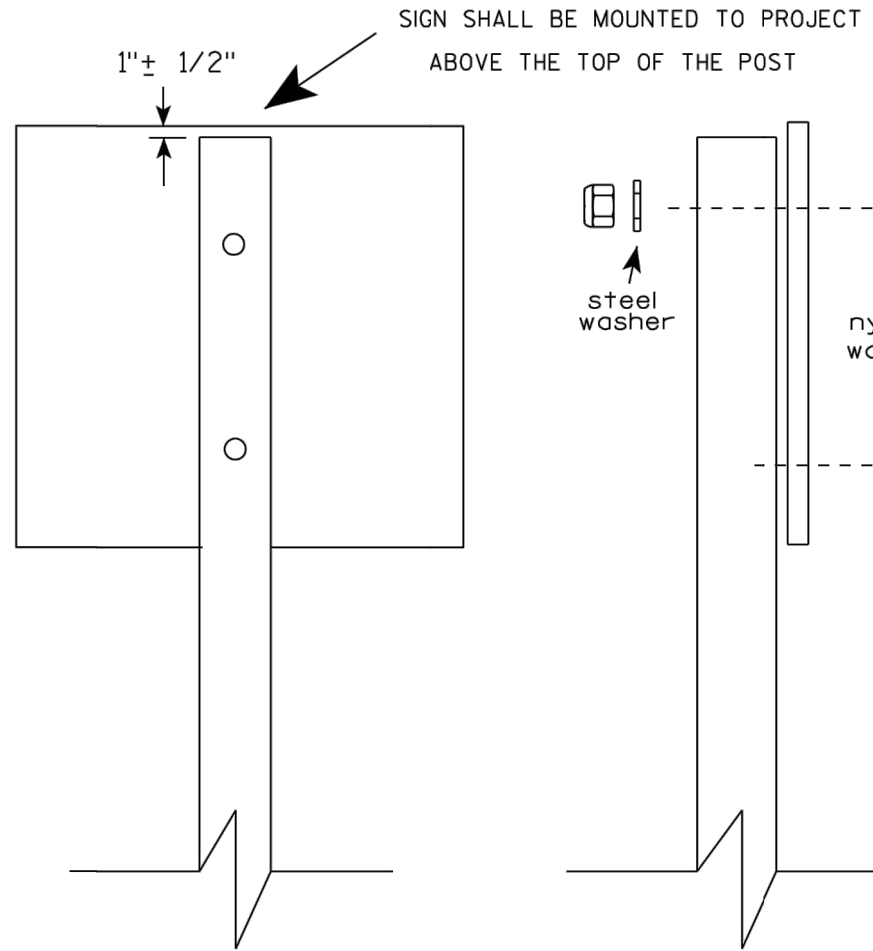

Nuts, bolts and lags used for mounting signs shall have hexagonal heads and shall be either :

- a. Hot dip galvanized in accordance with ASTM Designation: A 153, Class D, or SC 3
- b. Electro-galvanized in accordance with ASTM Designation : B 633, TYPE III, SC 3.

Threads on bolts and nuts shall be manufactured with sufficient allowance for the cadmium plate or galvanized coating to permit the nuts to run freely on the bolts.

- STRINGER BOLTING TO ALUMINUM SIGNS (SEE SIGN PLATE A4-18)
- MACHINE BOLTS - 5/16" X 1-3/4" Length w/ lock nuts
- WOOD POSTS (4" x 4" or 4" x 6")
- LAG SCREWS - 3/8" X 3" (NO STRINGERS ON BACK OF SIGN)
 - 3/8" X 4" (STRINGERS ON BACK OF SIGN)
- SQUARE STEEL POSTS (2" x 2")
- MACHINE BOLTS - 3/8" X 3-1/4" Length w/ nuts (NO STRINGER ON BACK OF SIGN)
 - 3/8" X 5" Length w/ nuts (STRINGERS ON BACK OF SIGN)
- RIVETS - 9/32" (6605-9-6) BULB-TITE, TRI-FOLD, ALUMINUM BODY/MANDREL
O.D. FLANGE .720-.765 INCH, GRIP RANGE .042-.375 INCH
- WASHERS (ALL POSTS) -
- 1-1/4" O.D. X 3/8" I.D. X 1/16" STEEL
 - 1-1/4" O.D. X 3/8" I.D. X .080 NYLON

* Two different fastening systems are shown for illustration purposes. On any individual sign, either one or the other system shall be used. Actual number of fasteners per sign varies with the sign area, but normally there are two. For a single post installation, all signs greater than 9 sq. ft. require the use of 3 fasteners.

ATTACHMENT OF SIGNS TO POSTS	
WISCONSIN DEPT OF TRANSPORTATION	
APPROVED	<i>Matthew R Rauch</i> For State Traffic Engineer
DATE <u>8/11/16</u>	PLATE NO. <u>A4-8.8</u>

7

ENGINEERED FILL GENERAL NOTES:
 1. THE ENGINEERED SOIL COMPOSITION SHOULD FOLLOW THE DNR TECHNICAL STANDARD 1004 FOR BIORETENTION. THE MIXTURE SHOULD CONTAIN 70-85% SAND AND 15-30% COMPOST.
 2. SAND SHALL MEET THE FOLLOWING GRADATION REQUIREMENTS AS SPECIFIED IN THE DNR TECHNICAL STANDARD 1004 FOR BIORETENTION: USDA COARSE SAND (.02-.04 INCHES), ASTM C33 (FINE AGGREGATE CONCRETE SAND) OR WISCONSIN STANDARDS AND SPECIFICATIONS FOR HIGHWAY AND STRUCTURE CONSTRUCTION, SECTION 501.2.5.3.4 (FINE AGGREGATE CONCRETE SAND) RECENT EDITION OR AN EQUIVALENT AS APPROVED BY THE ADMINISTERING AUTHORITY. MANUFACTURED SAND OR STONE DUST IS NOT ALLOWED. SAND MUST BE WASHED AND DRAINED TO REMOVE CLAY AND SILT PARTICLES PRIOR TO MIXING.
 3. THE COMPOST SHALL MEET THE REQUIREMENT OF WISCONSIN DNR SPECIFICATION S100, COMPOST.

SITE STABILIZATION NOTE:
 CONSTRUCTION SITE RUNOFF FROM DISTURBED AREAS SHALL NOT BE ALLOWED TO ENTER THE BIORETENTION DEVICE / ENGINEERED SOIL. RUNOFF FROM PERVIOUS AREAS SHALL BE DIVERTED FROM THE DEVICE UNTIL THE PERVIOUS AREAS HAVE UNDERGONE FINAL STABILIZATION. CONTRACTOR TO KEEP THE BASIN AT THE FINISHED FLOOR ELEVATION (TOP OF ENGINEERED SOIL) UNTIL SITE IS STABILIZED. INSTALL THE ENGINEERED MEDIA ONCE THE PERVIOUS AREAS ARE STABILIZED.

BIO-RETENTION BASIN NOTES:
 1. THE BIO-RETENTION BASIN SHALL BE EXCAVATED TO ELEVATION 1106.28 AND SERVE AS A SEDIMENT BASIN DURING CONSTRUCTION. AFTER THE REMAINDER OF THE SITE IS STABILIZED, THE BIO-FILTER SHALL BE FULLY EXCAVATED, BACKFILLED, PLANTED AND PUT INTO SERVICE.
 2. THE BASIN SIDE SLOPED SHALL BE SEEDED WITH NATIVE PRAIRIE GRASS. THE BASIN FLOOR SHALL BE PLANTED WITH A MINIMUM OF THREE DIFFERENT SPECIES OF GRASSES AND UTILIZE PLUGS SPACED A MAXIMUM OF 12-INCHES ON CENTER. THE CONTRACTOR SHALL PREPARE A PLANTING PLAN FOR THE BIO-INFILTRATION BASIN AND SUBMIT TO THE ENGINEER FOR APPROVAL. THE PLAN SHALL IDENTIFY ALL PLANT SPECIES, LOCATIONS, AND MAINTENANCE REQUIREMENTS FOR THE FIRST YEAR WARRANTY PERIOD. THE CONTRACTOR WILL BE RESPONSIBLE FOR ALL MAINTENANCE, MULCHING, WEEDING, AND REPLANTING AS NECESSARY THROUGHOUT THE WARRANTY PERIOD.

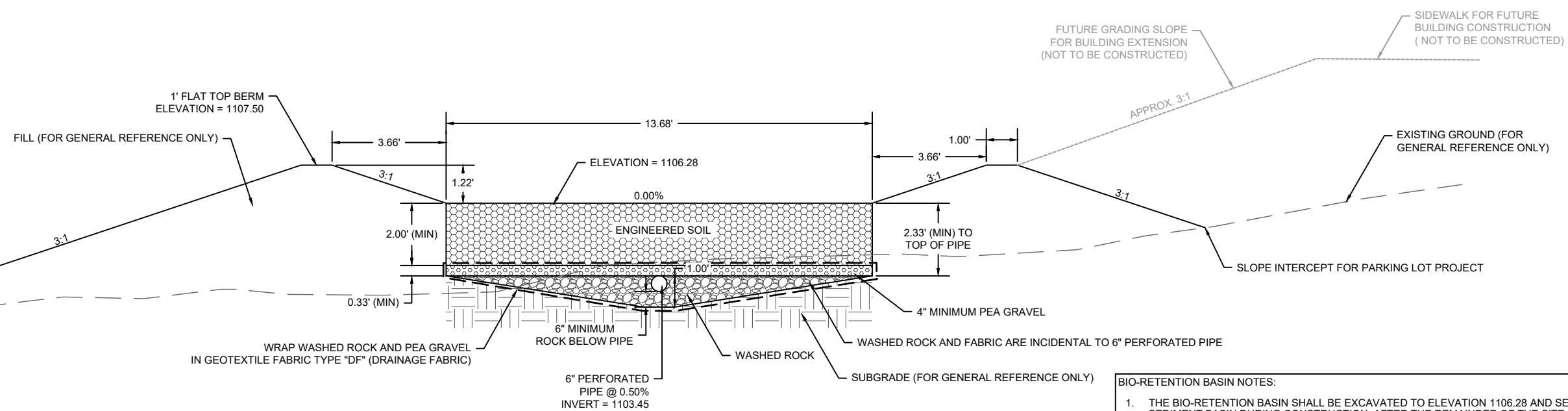

BIORETENTION BASIN - EAST END TYPICAL SECTION
 NO SCALE TYPICAL SECTION IS LOOKING WEST

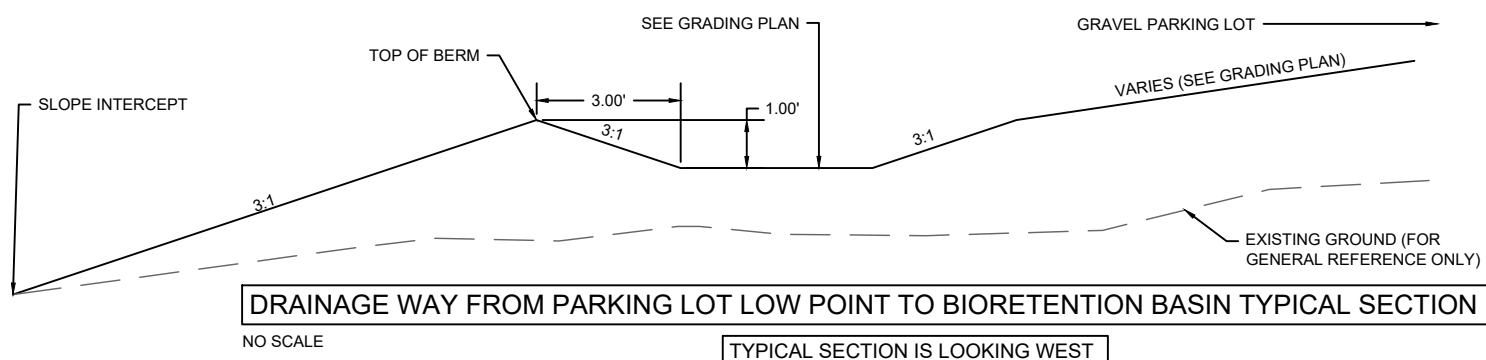

DRAINAGE WAY FROM PARKING LOT LOW POINT TO BIORETENTION BASIN TYPICAL SECTION
 NO SCALE TYPICAL SECTION IS LOOKING WEST

BIORETENTION BASIN - WEST END / OVERFLOW STRUCTURE TYPICAL SECTION
 NO SCALE TYPICAL SECTION IS LOOKING WEST

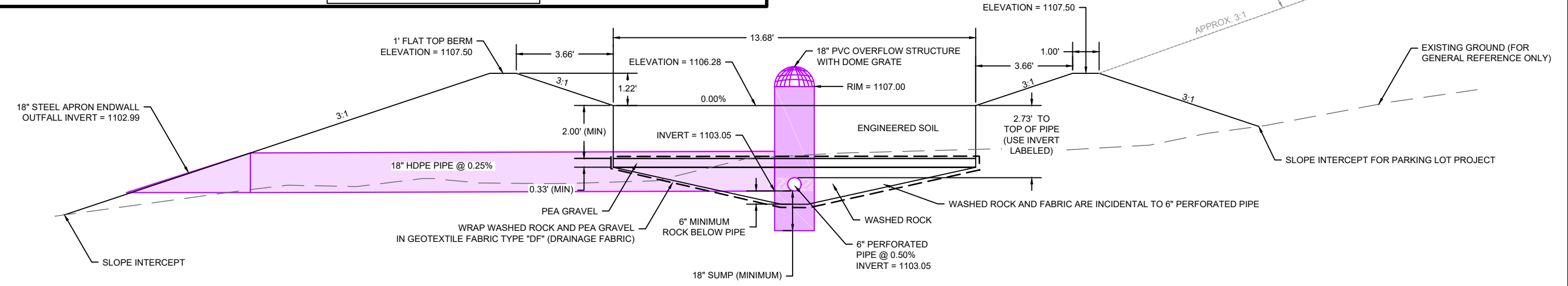

PROJECT DATE:	DRAWN BY:	NO.	DATE	REVISION	BY:
	JFK				
	JFK				
	CDG				

MSA
 ENGINEERING | ARCHITECTURE | SURVEYING
 FUNDING | PLANNING | ENVIRONMENTAL
 146 North Central Ave, Marshfield WI 54449
 (715) 384-2133 www.msa-ps.com
 © MSA Professional Services, Inc.

GRANTON SCHOOLS SOUTH PARKING LOT
 GRANTON AREA SCHOOL DISTRICT
 CLARK COUNTY, WISCONSIN

BIORETENTION BASIN TYPICAL SECTIONS & OVERFLOW STRUCTURE DETAIL

PROJECT NO:
1486602
 SHEET
C014

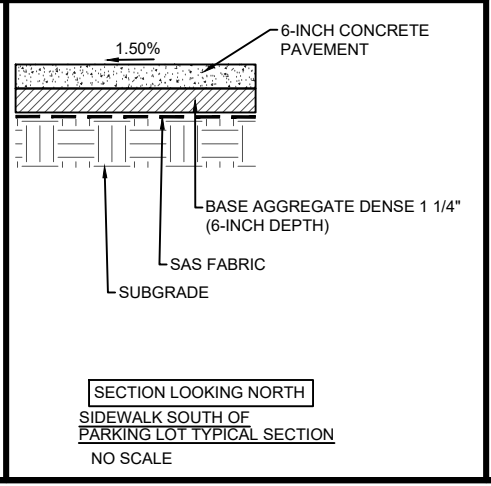
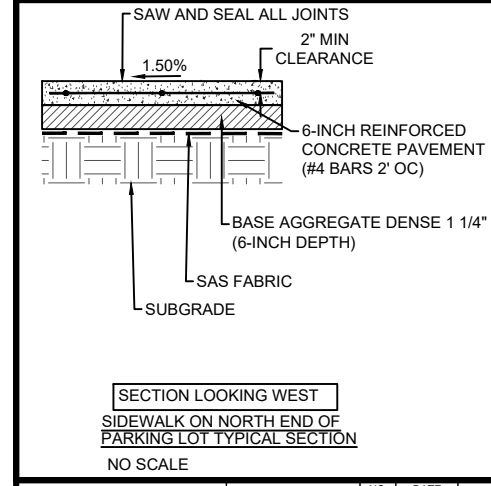
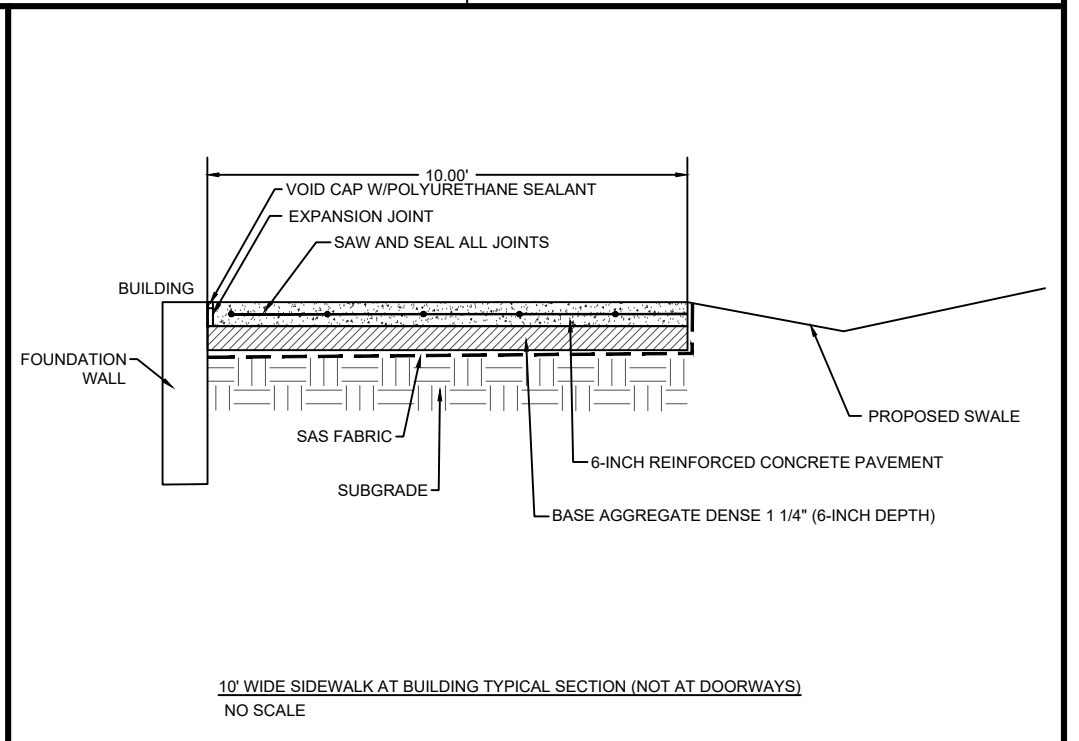
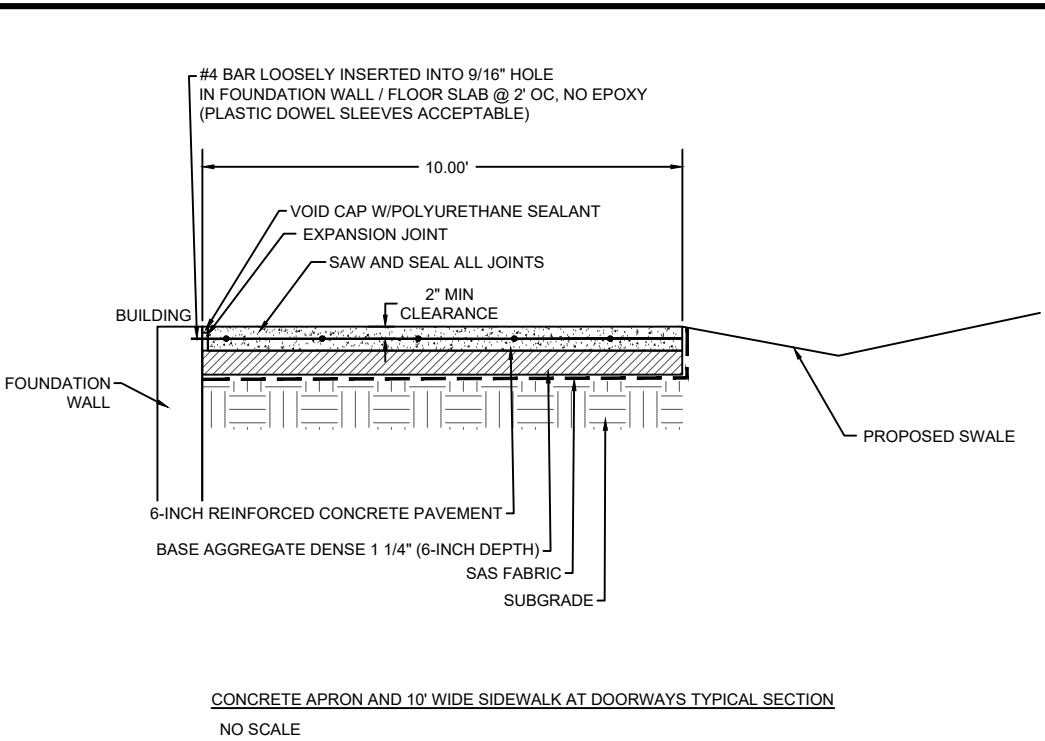
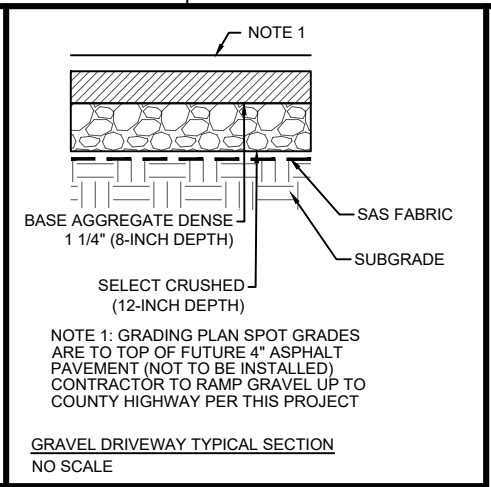
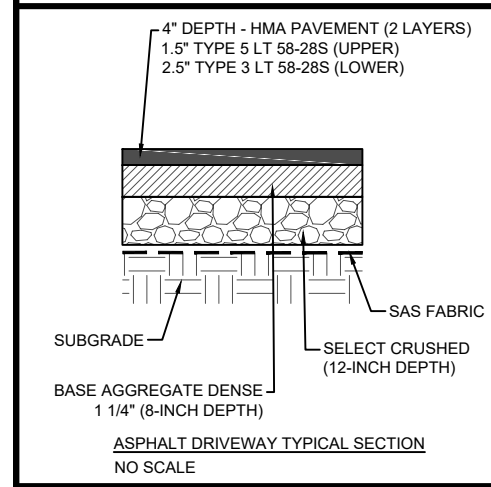
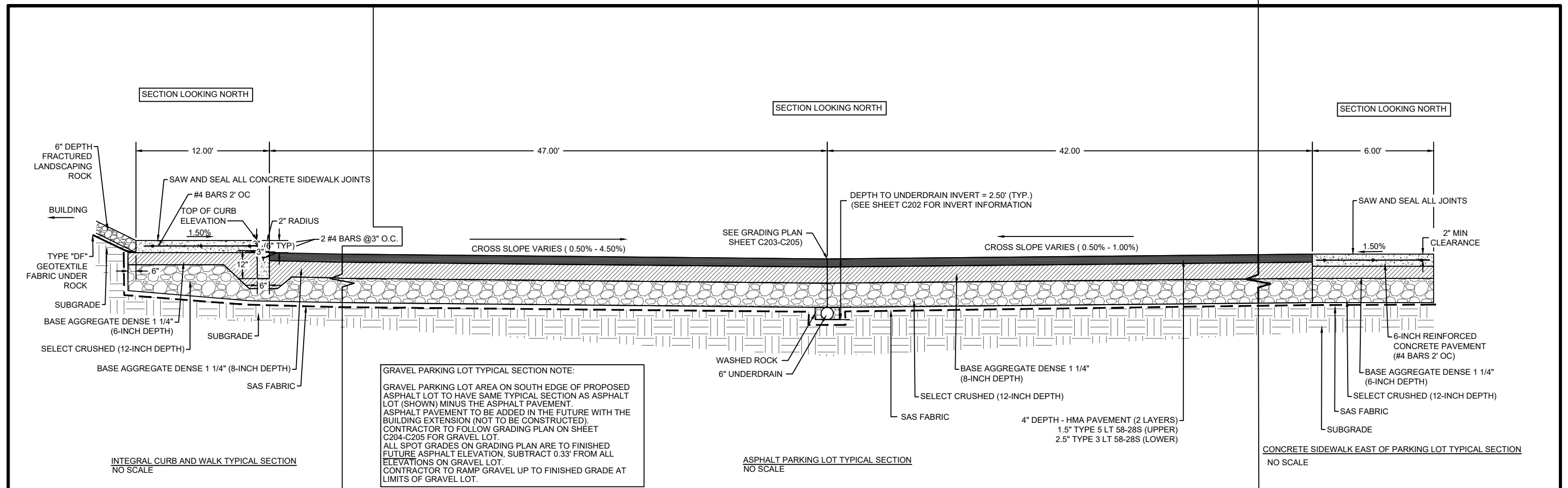

PROJECT DATE:	DRAWN BY:	NO.	DATE	REVISION	BY:
4/29/2022 4:06 PM, G:\14148666\1486602\CADD\Construction Documents\PLAN PRODUCTION DRAWINGS\GENERALS AND DETAILS.dwg	JFK				
	DESIGNED BY: JFK				
	CHECKED BY: CDG				

MSA ENGINEERING | ARCHITECTURE | SURVEYING
FUNDING | PLANNING | ENVIRONMENTAL
146 North Central Ave, Marshfield WI 54449
(715) 384-2133 www.msa-ps.com
© MSA Professional Services, Inc.

GRANTON SCHOOLS SOUTH PARKING LOT
GRANTON AREA SCHOOL DISTRICT
CLARK COUNTY, WISCONSIN

PARKING LOT, SIDEWALK, AND DRIVEWAY TYPICAL
SECTIONS

PROJECT NO:
1486602
SHEET
C015

REFER TO SHEET C202
(UTILITY PLAN) FOR EXACT
STORM PIPE AND STRUCTURE
INFORMATION.

REFER TO SHEET C203-205
(GRADING PLAN) FOR EXACT
GRADING INFORMATION.

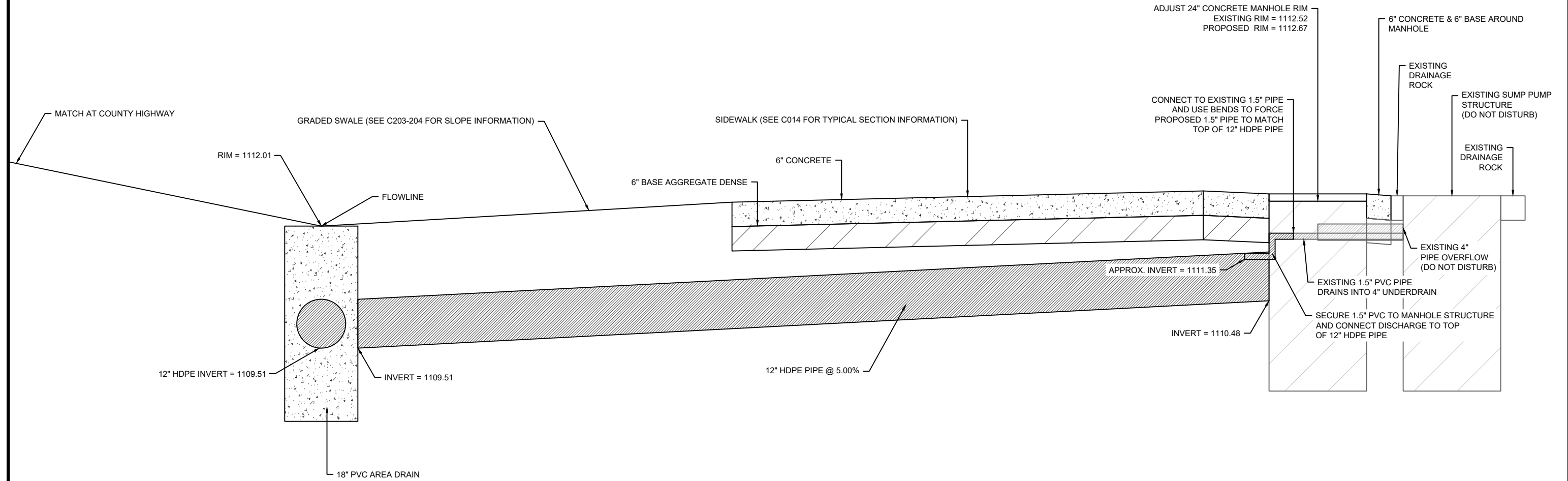

BUILDING SUMP PUMP 1 CONNECTION DETAIL

DETAIL SECTION LOOKING SOUTH

PROJECT DATE:	DRAWN BY:	NO.	DATE	REVISION	BY:
	JFK	-	-	-	-
	JFK	-	-	-	-
	CDG	-	-	-	-

PLOT DATE: 4/29/2022 4:06 PM, G:\1414866\14866002\CADD\Construction Documents\PLAN PRODUCTION DRAWINGS\GENERALS AND DETAILS.dwg



ENGINEERING | ARCHITECTURE | SURVEYING
FUNDING | PLANNING | ENVIRONMENTAL
146 North Central Ave, Marshfield WI 54449
(715) 384-2133 www.msa-ps.com
© MSA Professional Services, Inc.

GRANTON SCHOOLS SOUTH PARKING LOT
GRANTON AREA SCHOOL DISTRICT
CLARK COUNTY, WISCONSIN

BUILDING SUMP PUMP 1 CONNECTION DETAIL

PROJECT NO.
1486602
SHEET
C016

BUILDING SUMP PUMP 2 CONNECTION DETAIL

DETAIL SECTION LOOKING EAST

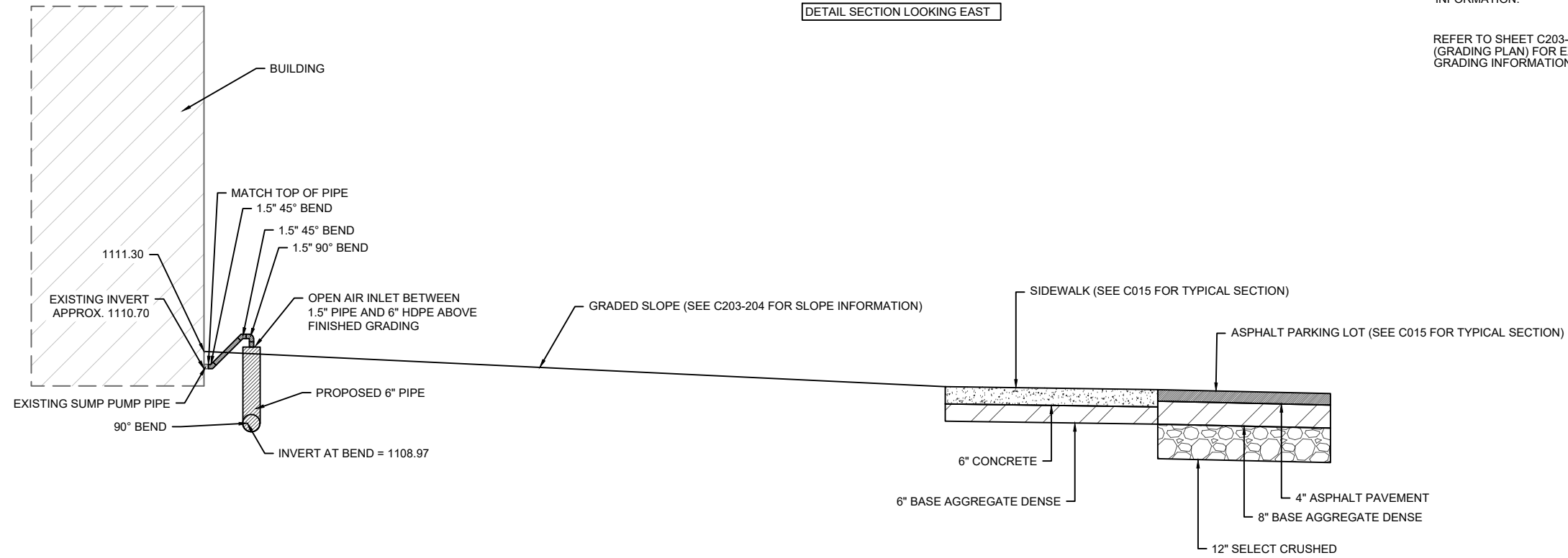

REFER TO SHEET C202
(UTILITY PLAN) FOR EXACT
STORM PIPE AND STRUCTURE
INFORMATION.

REFER TO SHEET C203-205
(GRADING PLAN) FOR EXACT
GRADING INFORMATION.

BUILDING SUMP PUMP 2 CONNECTION DETAIL

DETAIL SECTION LOOKING NORTH

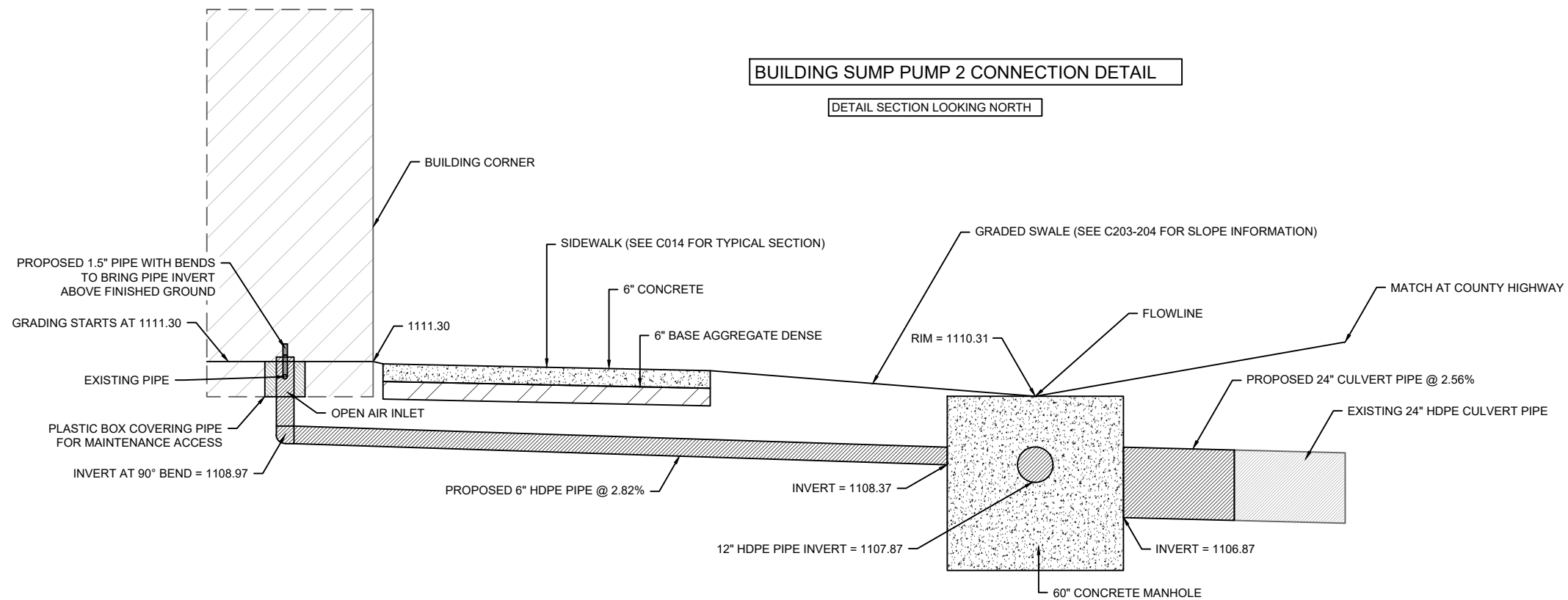

PROJECT DATE:	DRAWN BY:	NO.	DATE	REVISION	BY:
	JFK	-	-	-	-
	JFK	-	-	-	-
	CDG	-	-	-	-



ENGINEERING | ARCHITECTURE | SURVEYING
FUNDING | PLANNING | ENVIRONMENTAL
146 North Central Ave, Marshfield WI 54449
(715) 384-2133 www.msa-ps.com
© MSA Professional Services, Inc.

GRANTON SCHOOLS SOUTH PARKING LOT
GRANTON AREA SCHOOL DISTRICT
CLARK COUNTY, WISCONSIN

BUILDING SUMP PUMP 2 CONNECTION DETAIL

PROJECT NO.
1486602
SHEET
C017

REFER TO SHEET C202
(UTILITY PLAN) FOR EXACT
STORM PIPE AND STRUCTURE
INFORMATION.

REFER TO SHEET C203-205
(GRADING PLAN) FOR EXACT
GRADING INFORMATION.

BUILDING DRAIN AND SUMP PUMP 3 CONNECTION DETAIL

DETAIL SECTION LOOKING WEST

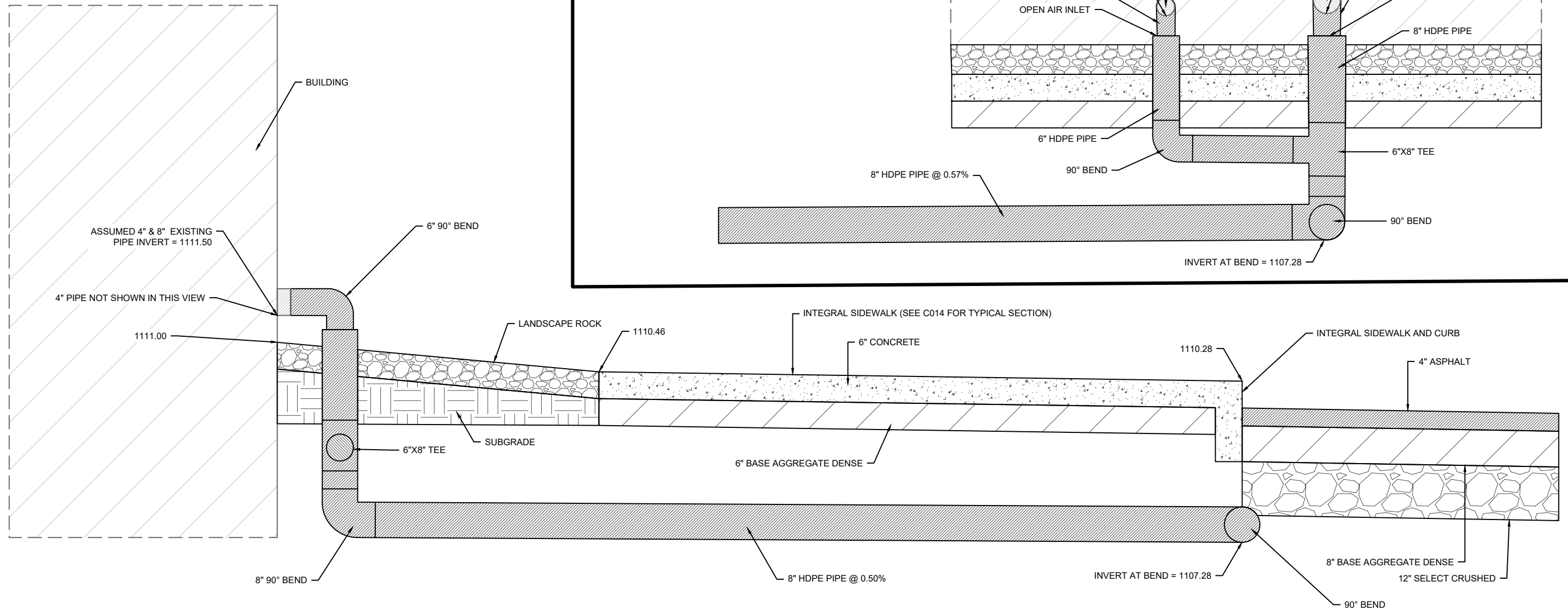
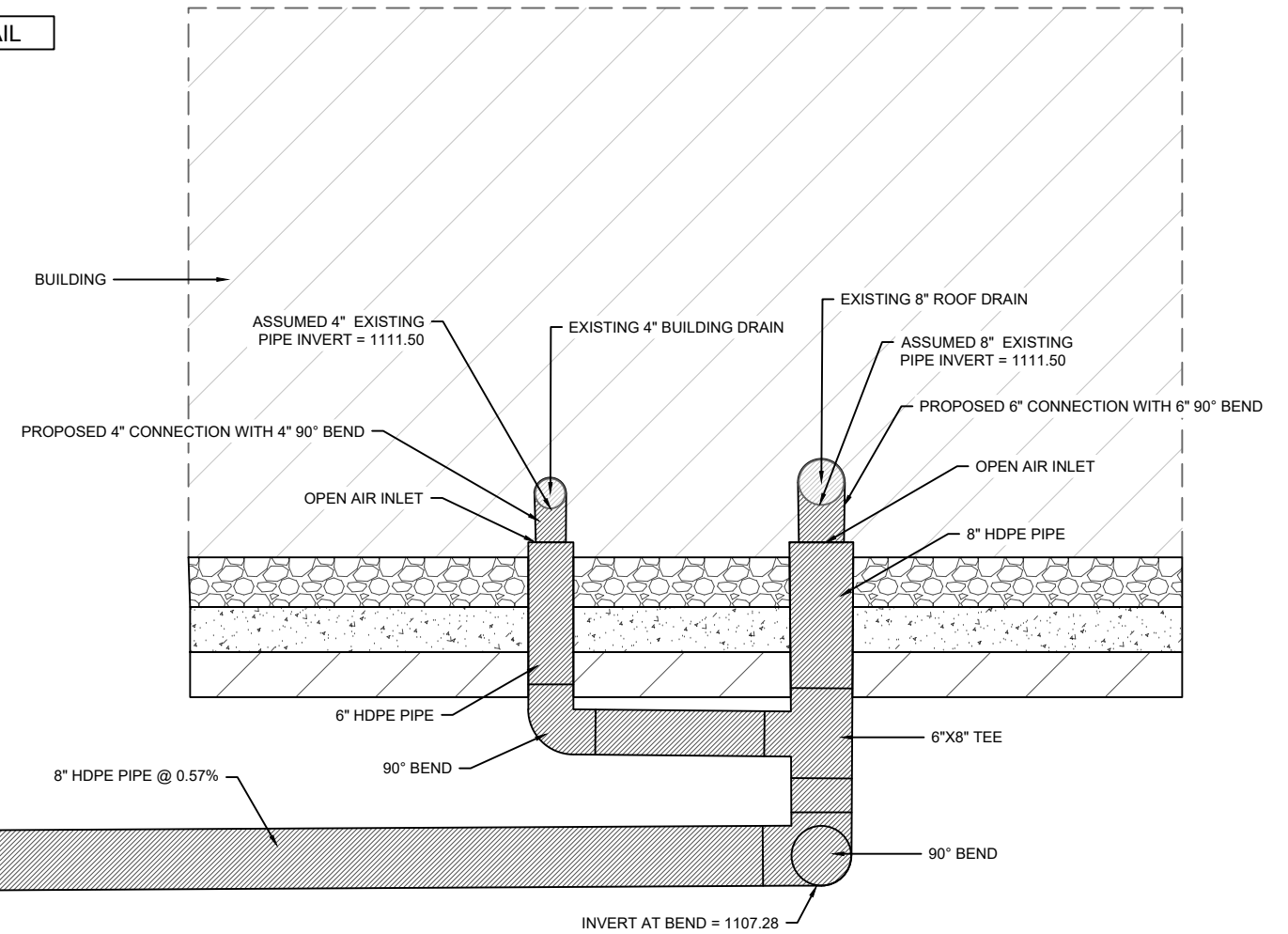

BUILDING DRAIN AND SUMP PUMP 3 CONNECTION DETAIL

DETAIL SECTION LOOKING NORTH

PROJECT DATE:	DRAWN BY:	NO.	DATE	REVISION	BY:
	JFK				
	JFK				
	CDG				



ENGINEERING | ARCHITECTURE | SURVEYING
FUNDING | PLANNING | ENVIRONMENTAL
146 North Central Ave, Marshfield WI 54449
(715) 384-2133 www.msa-ps.com
© MSA Professional Services, Inc.

GRANTON SCHOOLS SOUTH PARKING LOT
GRANTON AREA SCHOOL DISTRICT
CLARK COUNTY, WISCONSIN

BUILDING DRAIN AND SUMP PUMP 3 CONNECTION DETAIL

PROJECT NO.
1486602
SHEET
C018

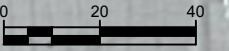
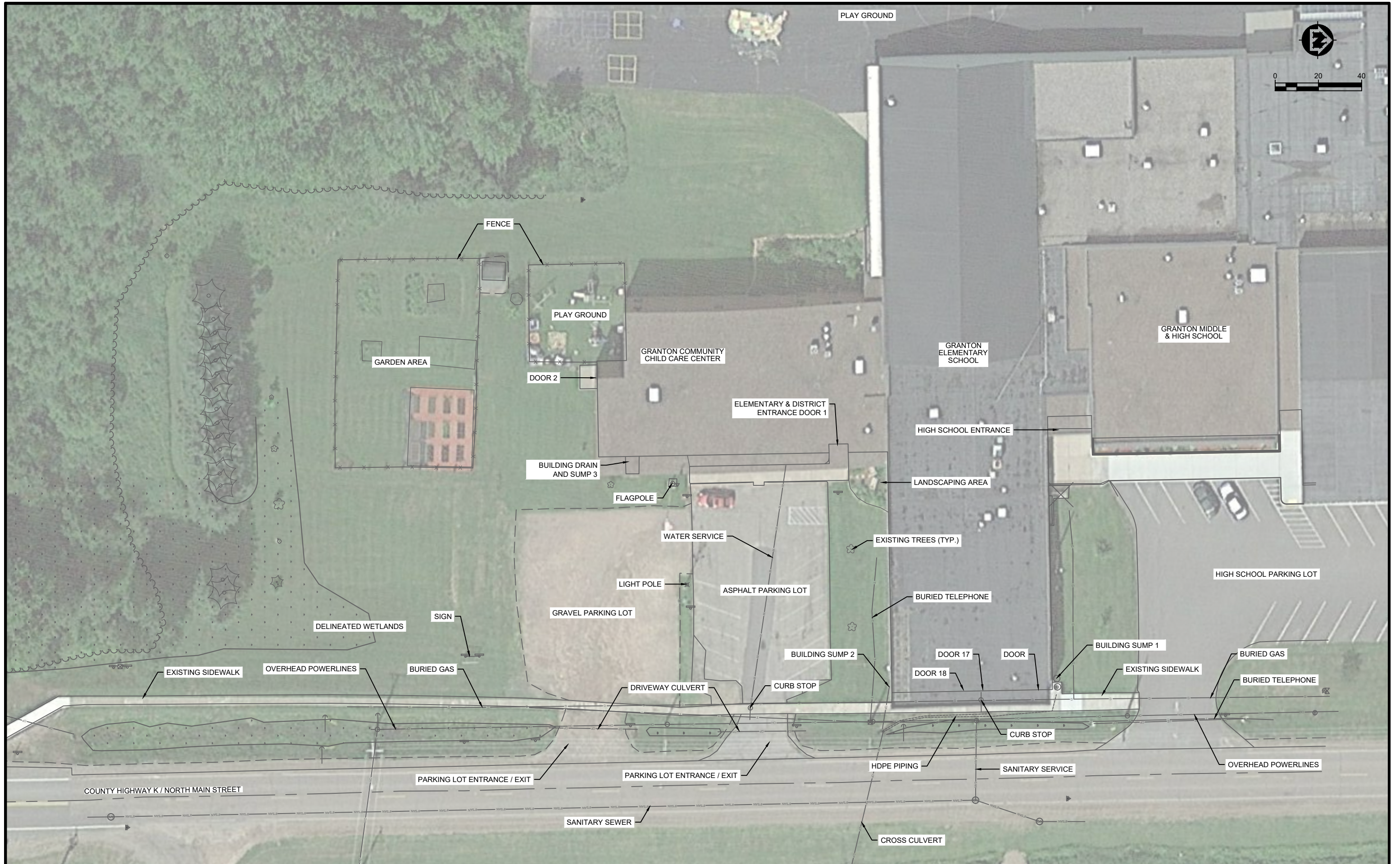

PROJECT DATE:	NO.	DATE	REVISION	BY:
DRAWN BY: JFK				
DESIGNED BY: JFK				
CHECKED BY: CDG				



ENGINEERING | ARCHITECTURE | SURVEYING
 FUNDING | PLANNING | ENVIRONMENTAL
 146 North Central Ave, Marshfield WI 54449
 (715) 384-2133 www.msa-ps.com
 © MSA Professional Services, Inc.

GRANTON SCHOOLS SOUTH PARKING LOT
 GRANTON AREA SCHOOL DISTRICT
 CLARK COUNTY, WISCONSIN

EXISTING SITE CONDITIONS

PROJECT NO:
1486602
 SHEET
C100

PLOT DATE: 4/29/2022 4:10 PM, G:\1414866\1486602\CADD\Construction Documents\PLAN PRODUCTION DRAWINGS\EXISTING PLAN SHEETS.dwg

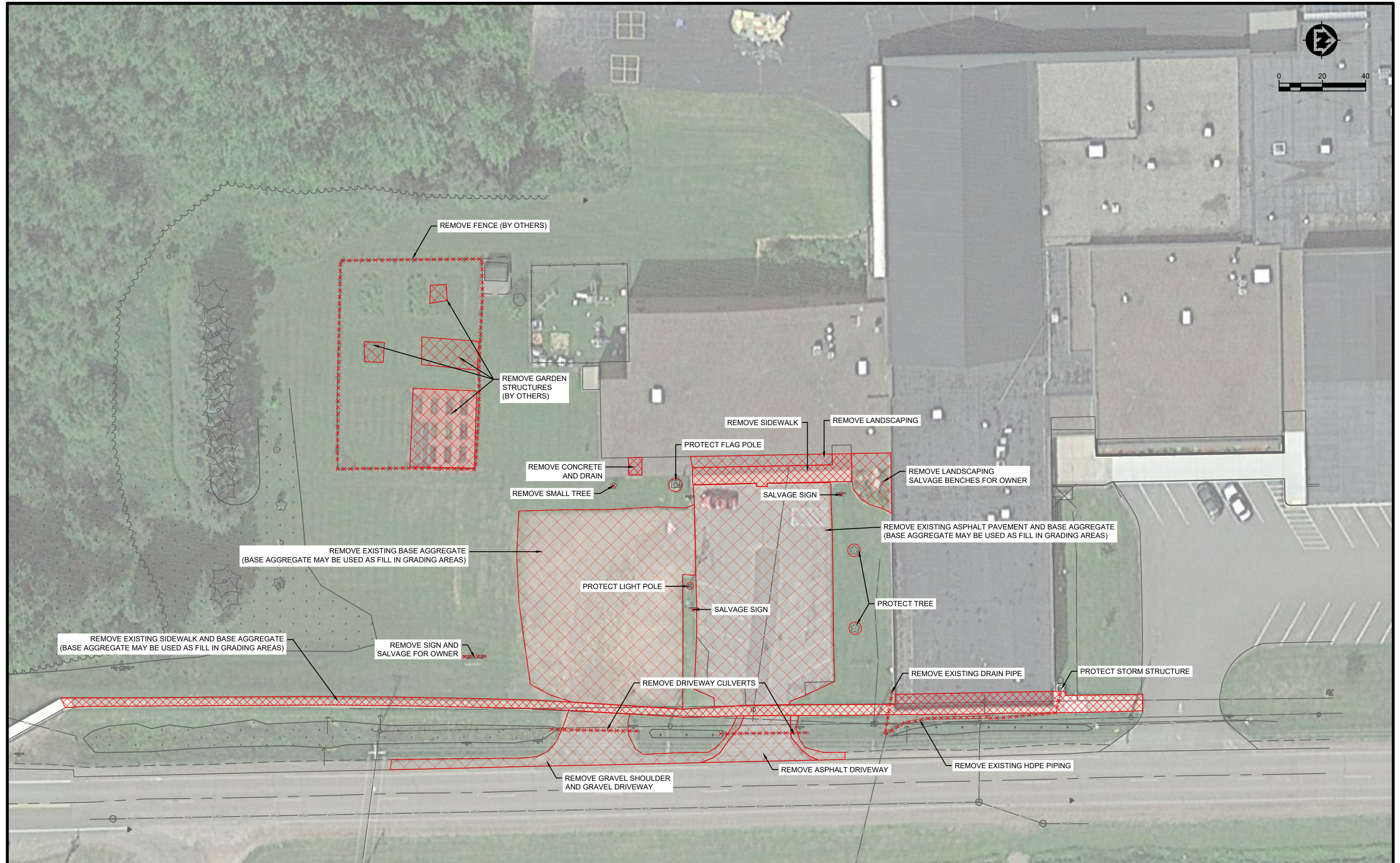
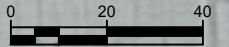

PROJECT DATE:	DRAWN BY:	NO.	DATE	REVISION	BY:
	JFK	-	-	-	-
	JFK	-	-	-	-
	CDG	-	-	-	-



ENGINEERING | ARCHITECTURE | SURVEYING
 FUNDING | PLANNING | ENVIRONMENTAL
 146 North Central Ave, Marshfield WI 54449
 (715) 384-2133 www.msa-ps.com
 © MSA Professional Services, Inc.

GRANTON SCHOOLS SOUTH PARKING LOT
 GRANTON AREA SCHOOL DISTRICT
 CLARK COUNTY, WISCONSIN

REMOVAL PLAN

PROJECT NO:
1486602
SHEET
C101

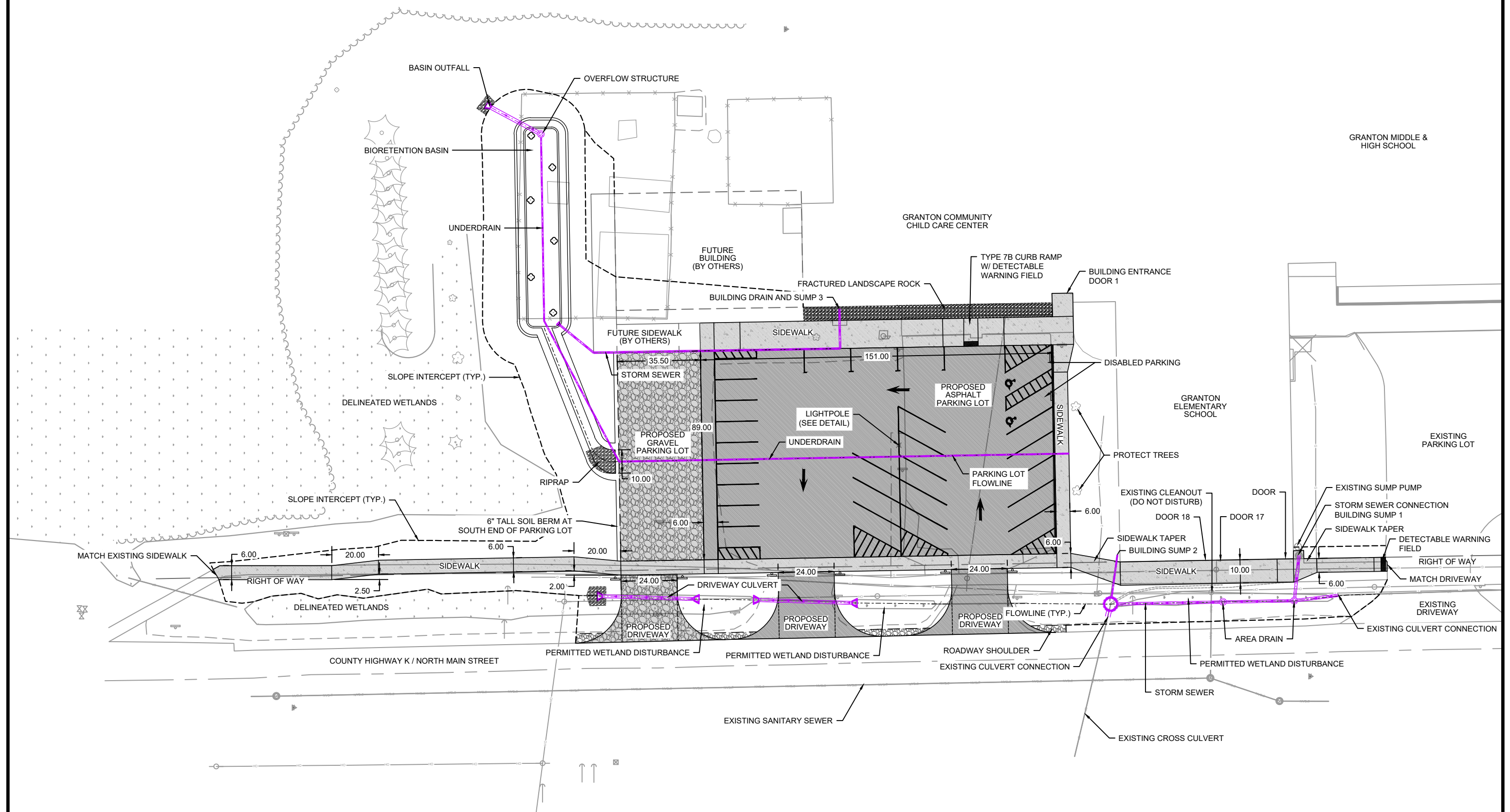
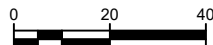

PROJECT DATE:	NO.	DATE	REVISION	BY:
DRAWN BY: JFK				
DESIGNED BY: JFK				
CHECKED BY: CDG				

MSA
 ENGINEERING | ARCHITECTURE | SURVEYING
 FUNDING | PLANNING | ENVIRONMENTAL
 146 North Central Ave, Marshfield WI 54449
 (715) 384-2133 www.msa-ps.com
 © MSA Professional Services, Inc.

GRANTON SCHOOLS SOUTH PARKING LOT
 GRANTON AREA SCHOOL DISTRICT
 CLARK COUNTY, WISCONSIN

PROPOSED SITE PLAN

PROJECT NO:
1486602
 SHEET:
C200

PLOT DATE: 4/29/2022 4:20 PM, G:\1414866\1486602\CADD\Construction Documents\PLAN PRODUCTION DRAWINGS\PROPOSED PLAN SHEETS.dwg



RESTORATION NOTE:
 ALL RESTORATION AREAS SHALL BE 6 INCHES TOPSOIL, FERTILIZER, SEED, AND EMAT.
 ALL EMAT AREAS SHALL BE URBAN CLASS 1 TYPE B.

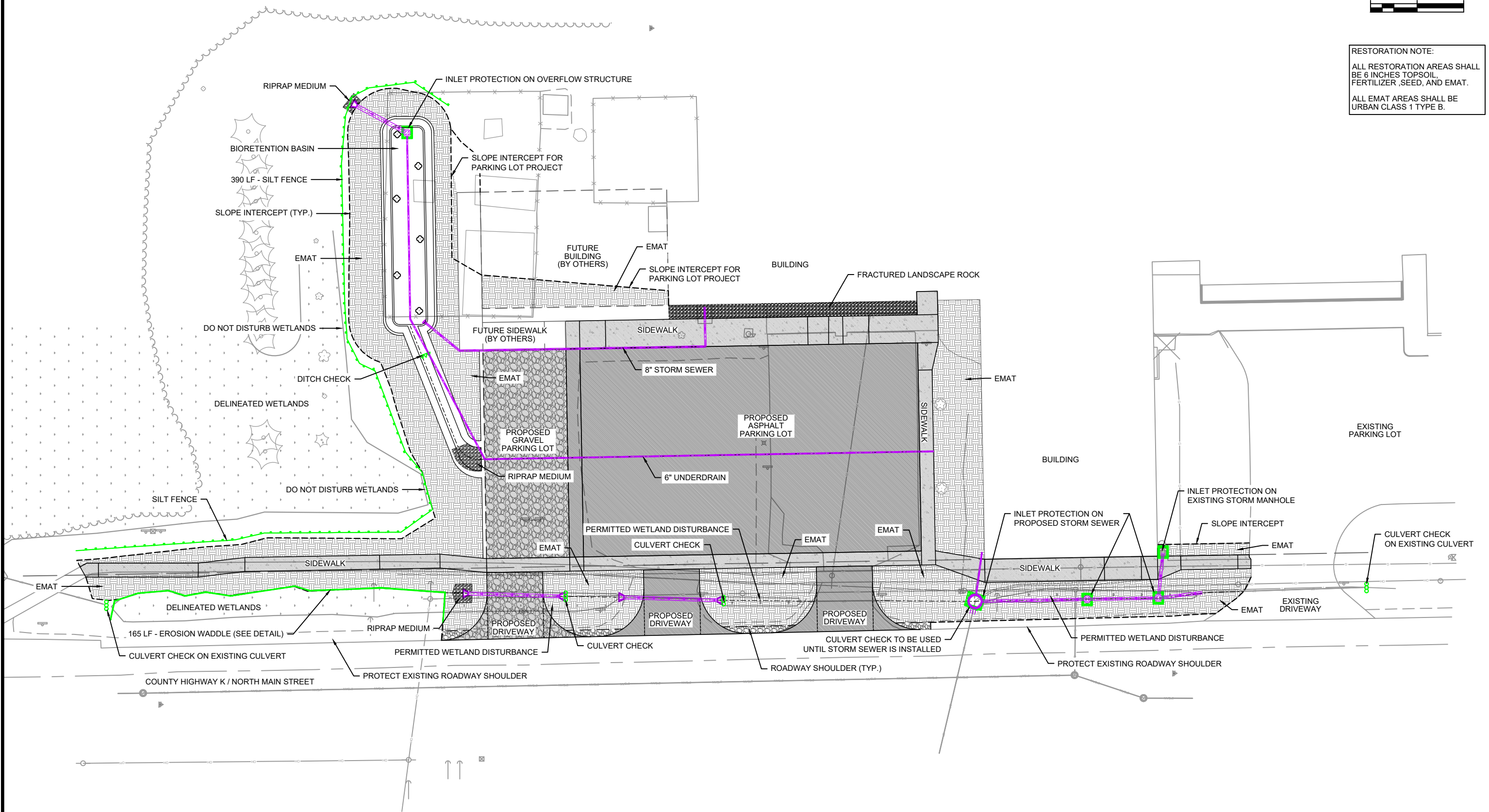

PROJECT DATE:	NO.	DATE	REVISION	BY:
DRAWN BY: JFK				
DESIGNED BY: JFK				
CHECKED BY: CDG				

PLOT DATE: 4/29/2022 2:10 PM, G:\1414866\1486602\CADD\Construction Documents\PLAN PRODUCTION DRAWINGS\PROPOSED PLAN SHEETS.dwg



ENGINEERING | ARCHITECTURE | SURVEYING
 FUNDING | PLANNING | ENVIRONMENTAL
 146 North Central Ave, Marshfield WI 54449
 (715) 384-2133 www.msa-ps.com
 © MSA Professional Services, Inc.

GRANTON SCHOOLS SOUTH PARKING LOT
 GRANTON AREA SCHOOL DISTRICT
 CLARK COUNTY, WISCONSIN

EROSION CONTROL PLAN

PROJECT NO:
1486602
 SHEET
C201

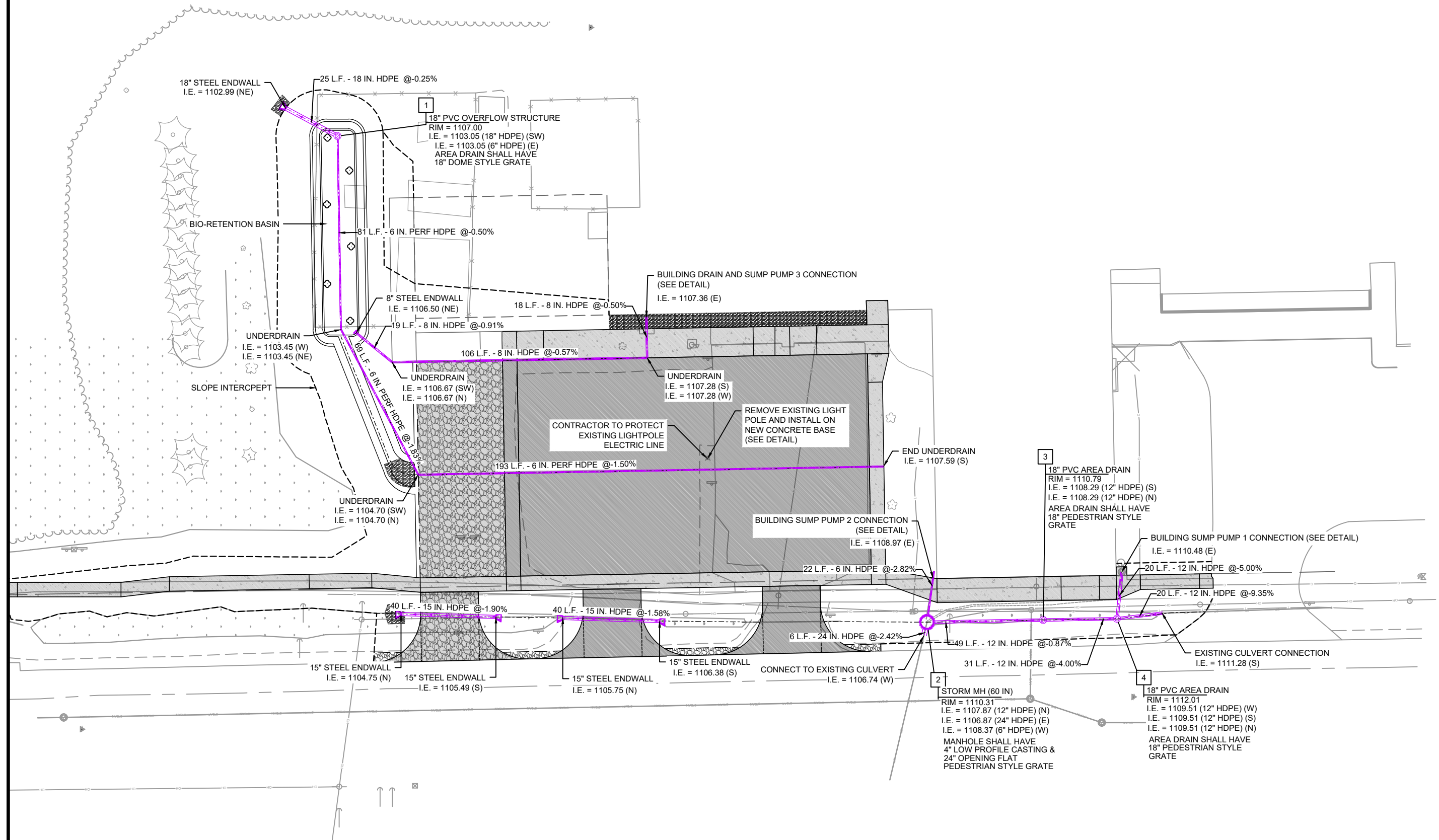
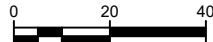

PROJECT DATE:	NO.	DATE	REVISION	BY:
DRAWN BY: JFK				
DESIGNED BY: JFK				
CHECKED BY: CDG				

PLOT DATE: 4/29/2022 4:19 PM, G:\1414866\1486602\CADD\Construction Documents\PLAN PRODUCTION DRAWINGS\PROPOSED PLAN SHEETS.dwg

ENGINEERING | ARCHITECTURE | SURVEYING
 FUNDING | PLANNING | ENVIRONMENTAL
 146 North Central Ave, Marshfield WI 54449
 (715) 384-2133 www.msa-ps.com
 © MSA Professional Services, Inc.

GRANTON SCHOOLS SOUTH PARKING LOT
 GRANTON AREA SCHOOL DISTRICT
 CLARK COUNTY, WISCONSIN

UTILITY PLAN
 PROJECT NO: 1486602
 SHEET: C202

BIORETENTION BASIN GRADING PLAN

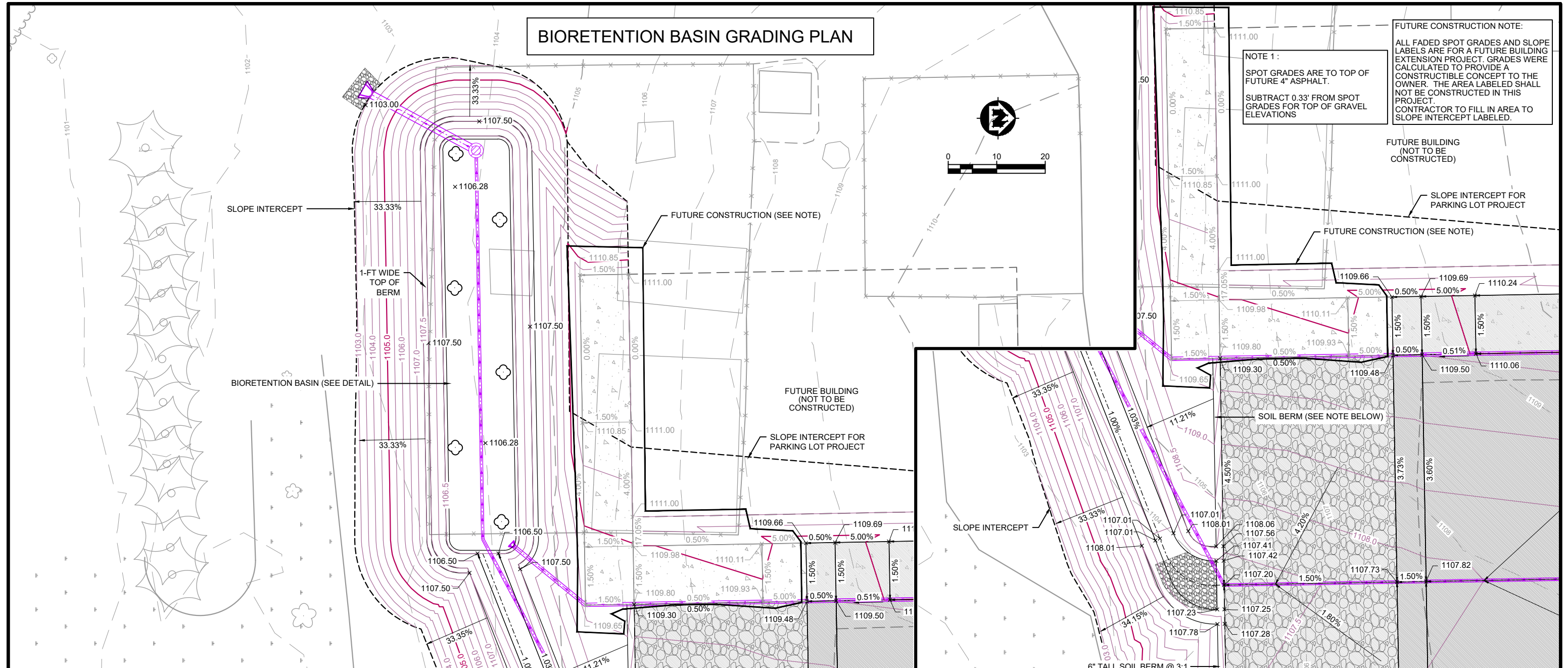

SOUTH SIDEWALK GRADING PLAN

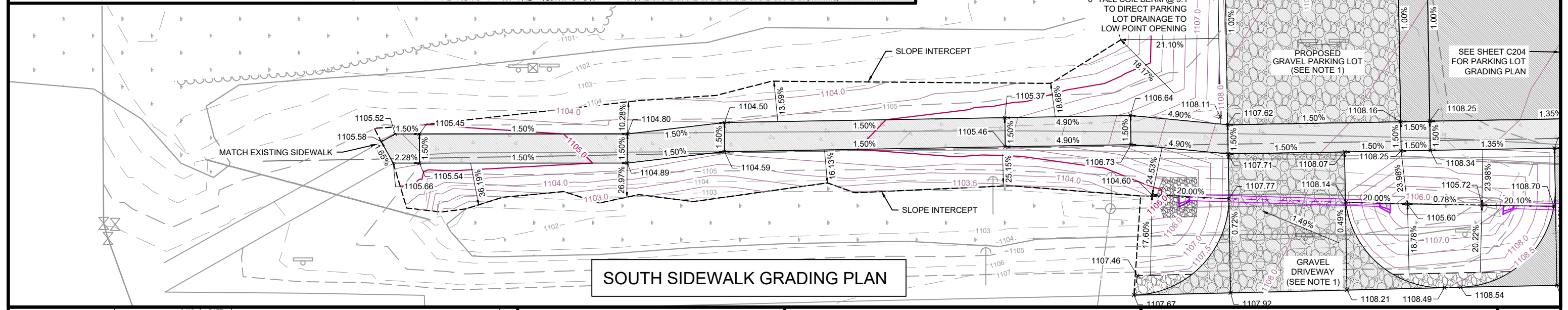

PROJECT DATE:	NO.	DATE	REVISION	BY
4/29/2022 2:23 PM, G:\1414866\1486602\CADD\Construction Documents\PLAN PRODUCTION DRAWINGS\PROPOSED PLAN SHEETS.dwg				

MSA
ENGINEERING | ARCHITECTURE | SURVEYING
FUNDING | PLANNING | ENVIRONMENTAL
146 North Central Ave, Marshfield WI 54449
(715) 384-2133 www.msa-ps.com
© MSA Professional Services, Inc.

GRANTON SCHOOLS SOUTH PARKING LOT
GRANTON AREA SCHOOL DISTRICT
CLARK COUNTY, WISCONSIN

BIORETENTION BASIN AND SOUTH SIDEWALK GRADING PLAN

PROJECT NO. 1486602
SHEET C205



May 18, 2022

James Kuchta, District Administrator
Granton Area School District
217 North Main Street
Granton, WI 54436

Re: Granton Parking Lot Reconstruction
Granton Area School District

Dear Mr. Kuchta:

Upon review of the bid received on May 18, 2022 for the above-referenced project, it was found that it was submitted by a qualified contractor. Should you wish to proceed with the project, it is our recommendation that the low responsive bidder listed below be accepted and award made at your next meeting.

Haas Sons, Inc.
203 East Birch Street
Thorp, WI 54771

Base Bid: \$363,351.15

Please execute the enclosed Notice of Award for the contract. Once the form is signed, please email a copy back to dspindler@msaps.com. After receiving the executed copy, we will forward one copy of the Notice of Award and the remaining contract package to the Contractor.

Sincerely,
MSA Professional Services, Inc.



Chad Grundemann, Project Manager

dds
Enc.

NOTICE OF AWARD

Date: May 20, 2022

Project:

Granton South Parking Lot Reconstruction

Owner:

Granton Area School District

Owner's Contract No.:

Contract:

Granton Area School District - Granton South Parking Lot

Engineer's Project No.:

14866002

Bidder:

Haas Sons, Inc.

Bidder's Address: *[send Notice of Award Certified Mail, Return Receipt Requested]*

203 East Birch Street

Thorp, WI 54771

You are notified that your Bid dated May 18, 2022 for the above Contract has been considered. You are the Successful Bidder and are awarded a Contract for Granton South Parking Lot Reconstruction

The Contract Price of your Contract is Three-hundred sixty-three thousand three-hundred fifty-one Dollars Fifteen Cents (\$363,351.15).

[1] copies of the proposed Contract Documents (except Drawings) accompany this Notice of Award.

[3] sets of the Drawings will be delivered separately or otherwise made available to you immediately.

You must comply with the following conditions precedent within [15] days of the date you receive this Notice of Award.

1. Deliver to the Owner [1] fully executed counterparts of the Contract Documents.
2. Deliver with the executed Contract Documents the Contract security [Bonds] as specified in the Instructions to Bidders (Article 20), General Conditions (Paragraph 5.01), and Supplementary Conditions (Paragraph SC-5.01).
3. Other conditions precedent:

Failure to comply with these conditions within the time specified will entitle Owner to consider you in default, annul this Notice of Award, and declare your Bid security forfeited.

Within ten days after you comply with the above conditions, Owner will return to you one fully executed counterpart of the Contract Documents.

Granton Area School District

Owner

By: _____

Authorized Signature

District Administrator

Title

Copy to Engineer

School District of Granton South Parking Lot Reconstruction (#8188920)

Owner: Granton Area School District

Solicitor: MSA Professional Services - Marshfield

05/18/2022 09:00 AM CDT

Item No.	Item Description	UofM	Quantity	Haas Sons, Inc.	
				Unit Price	Extension
Base Bid					
1	Mobilization, Bonds, and Insurance	LS	1	\$33,000.00	\$33,000.00
2	Concrete Quality Control	LS	1	\$3,000.00	\$3,000.00
3	Traffic Control	LS	1	\$1,500.00	\$1,500.00
4	Clearing and Grubbing	LS	1	\$7,500.00	\$7,500.00
5	Dewatering	LS	1	\$1,000.00	\$1,000.00
6	Erosion and Sedimentation Controls	LS	1	\$2,500.00	\$2,500.00
7	Site Maintenance and Restoration	LS	1	\$13,875.00	\$13,875.00
8	Insulation (Undistributed, If Needed)	SF	128	\$4.00	\$512.00
9	Erosion Mat	SY	1640	\$2.05	\$3,362.00
10	Ditch Check	EA	1	\$225.00	\$225.00
11	Culvert Pipe Check	EA	5	\$150.00	\$750.00
12	Inlet Protection	EA	4	\$150.00	\$600.00
13	Tracking Pad	EA	1	\$1,000.00	\$1,000.00
14	Riprap, Medium, With Type HR Fabric	SY	25	\$4.00	\$100.00
15	Storm Sewer, HDPE, 6-Inch	LF	18	\$133.00	\$2,394.00
16	Storm Sewer, HDPE, 8-Inch	LF	142	\$55.00	\$7,810.00
17	Storm Sewer, HDPE, 12-Inch	LF	119	\$57.50	\$6,842.50
18	Storm Sewer, HDPE, 15-Inch	LF	80	\$61.00	\$4,880.00
19	Storm Sewer, HDPE, 18-Inch	LF	24	\$65.00	\$1,560.00
20	Storm Sewer, HDPE, 24-Inch	LF	5	\$75.55	\$377.75
21	Apron Endwalls, Steel, 8-Inch	EA	1	\$550.00	\$550.00
22	Apron Endwalls, Steel, 15-Inch	EA	4	\$800.00	\$3,200.00
23	Apron Endwalls, Steel, 18-Inch	EA	1	\$1,000.00	\$1,000.00
24	Pipe Underdrain, HDPE, 6-Inch	LF	341	\$23.00	\$7,843.00
25	Storm Drainage Inlet, Frames and Covers, Complete, 5-FT Diameter	EA	1	\$6,000.00	\$6,000.00
26	Storm Drainage Inlet, PVC & Ductile Iron, Complete, 18-Inch Diameter	EA	3	\$4,400.00	\$13,200.00
27	Connect to Existing Storm Sewer	EA	3	\$950.00	\$2,850.00
28	Connect to Existing Building Drain	EA	3	\$1,050.00	\$3,150.00
29	Bioretention Basin	LS	1	\$16,425.00	\$16,425.00
30	Geotextile Fabric, Type SAS	SY	2260	\$3.00	\$6,780.00
31	Unclassified Excavation	LS	1	\$26,500.00	\$26,500.00
32	Excavation Below Subgrade (Undistributed, If Needed)	CY	50	\$44.00	\$2,200.00
33	Granular Fill (Undistributed, If Needed)	CY	50	\$30.00	\$1,500.00
34	Select Crushed Material, 12-Inch Depth	SY	2260	\$15.00	\$33,900.00
35	Dense Graded Base, 1 1/4-Inch, 8-Inch Depth	SY	2210	\$15.00	\$33,150.00
36	Landscape Rock	SF	925	\$4.00	\$3,700.00
37	Asphaltic Concrete Pavement, 4-Inch Depth	SY	1790	\$29.25	\$52,357.50
38	Concrete Sidewalk, Reinforced, 6-Inch Depth, With 6-Inch Base	SF	5930	\$7.58	\$44,949.40
39	Detectable Warning Fields	SF	40	\$45.00	\$1,800.00
40	Pavement Marking, Paint, 4-Inch, White, Lot Lines	LF	1120	\$1.15	\$1,288.00
41	Pavement Marking, Paint, Symbol, White, Arrow	EA	3	\$30.00	\$90.00
42	Pavement Marking, Paint, Symbol, White, Handicap	EA	2	\$75.00	\$150.00
43	Sign	SF	24	\$20.00	\$480.00
44	Sign Post, Tubular Steel	EA	8	\$725.00	\$5,800.00
45	Concrete Base For Pole, Type P2	EA	1	\$1,700.00	\$1,700.00
Base Bid Total:					\$363,351.15

Granton Area School District

South Parking Lot Reconstruction

Summary of Bid as Compared to Planning Estimate

Original Construction Planning Level Estimate (January 2021)	\$	232,000.00
Soil Borings and Geotech Report - AET (Already Spent)	\$	3,200.00
Wetland Delineation, Survey, Design Engineering - MSA (Already Spent)	\$	29,300.00
Construction Admin & Observation - MSA (Not Yet Spent)	\$	7,400.00
Haas Sons Project Bid (Received May 18, 2022)	\$	363,351.15
New Total Project Cost (Based on Already Contracted Engineering & Actual Construction Bid Received)	\$	403,251.15
Portion of Bid Price Attributed to Increased Parking Lot and Sidewalk Areas Since January 2021 Planning Level Estimate	\$	51,667.90
Portion of Bid Price That Is Comparable to Originally Planned Project Area	\$	311,683.25
Original Construction Planning Level Estimate (January 2021)	\$	232,000.00
Difference Between Planning Estimate and Bid	\$	79,683.25
Percent Difference Between Planning Estimate and Bid		34%

Granton Area Schools - South Parking Lot Reconstruction
Preliminary Project Cost Estimate

Prepared By: MSA Professional Services, Inc.

November 5, 2014

Scope of Work: Parking lot will be replaced with a typical section of 4-inches of Asphaltic Pavement, 8-inches of Crushed Aggregate Base course, and 12-inches of Breaker Run Stone. No concrete curb & gutter is anticipated. A six inch drain perforated drain tile will be installed and will drain to the existing ditch on CTH 'K'. Sidewalks along the School and CTH K will be replaced as part of this project. The only storm sewer anticipated is driveway culverts.

Assumptions: All work will be performed within existing property limits. No wetlands will be affected by this project. Sidewalk replacement is as indicated in the attached exhibit. The project will be under one acre therefore no stormwater permit or BMPs are anticipated. The estimate assumes there is enough grade to discharge underdrain. If the underdrain cannot discharge to the surface, an alternate pavement and base option will need to be explored. Bus traffic is not anticipated.

ITEM DESCRIPTION	ESTIMATED QUANTITY	UNITS	UNIT PRICE	TOTAL PRICE
Mobilization, Bonds, and Insurance	1	LS	\$ 7,500.00	\$ 7,500.00
Common Excavation and Grading	1	LS	\$ 37,758.00	\$ 37,758.00
Erosion Control	1	LS	\$ 2,000.00	\$ 2,000.00
Traffic Control	1	LS	\$ 2,000.00	\$ 2,000.00
Turf Restoration	1	LS	\$ 2,500.00	\$ 2,500.00
4-Inch Asphalt Pavement	1,800	SY	\$ 18.00	\$ 32,400.00
6-Inch Concrete Sidewalk with Integral Curb w/Base	600	SF	\$ 6.00	\$ 3,600.00
6-Inch Concrete Sidewalk w/Base	260	SF	\$ 5.00	\$ 1,300.00
4-Inch Concrete Sidewalk w/Base	1,100	SF	\$ 4.50	\$ 4,950.00
Detectable Warning Fields	2	EA	\$ 300.00	\$ 600.00
15-Inch HDPE Culvert	80	LF	\$ 35.00	\$ 2,800.00
15-Inch Steel Endwalls	4	EA	\$ 175.00	\$ 700.00
Breaker Run (12-Inch Depth)	1,900	SY	\$ 7.00	\$ 13,300.00
Crushed Aggregate Base (8-Inch Depth)	1,900	SY	\$ 5.50	\$ 10,450.00
6-Inch Underdrain	240	LF	\$ 6.50	\$ 1,560.00
Excavation Below Subgrade (EBS)	150	CY	\$ 20.00	\$ 3,000.00
4-Inch Pavement Markings	800	LF	\$ 0.75	\$ 600.00
Accessible Pavement Markings	2	EA	\$ 50.00	\$ 100.00
Estimated Construction				\$ 127,118.00
Estimated Engineering				\$ 22,900.00
Estimated Contingency				\$ 12,700.00
Total Estimated Project Cost				\$ 162,718.00

Granton Area Schools

Project: School District of Granton 2021 Parking Lot Reconstruction

Project Description:

The project consists of the reconstruction of the existing south parking lot. The parking lot is expected to be replaced with a typical section of 4 inches of asphalt pavement over 8 inches of base aggregate dense and 12 inches of breaker run. Concrete curb & gutter is not desired by the Granton Area School District. 6 inch underdrain with clear stone trench is anticipated throughout the reconstructed lot. Sidewalk replacement adjacent to the south building wing and along CTH K, from the southern parking lot project limit to the south driveway of the north parking lot, is to be expected to be necessary. Some storm sewer pipe construction is expected to be necessary to convey roof and parking lot stormwater flows. The south lot project is expected to be required to meet 40% TSS reduction and is expected to need a bioretention basin.

ITEM NO.	ITEM DESCRIPTION	ESTIMATED QUANTITY	UNITS	UNIT PRICE	TOTAL PRICE
Base Bid					
1.	Mobilization, Bonds, and Insurance	1	LS	\$ 18,900.00	\$ 18,900.00
2.	Traffic Control	1	LS	\$ 1,600.00	\$ 1,600.00
3.	Erosion and Sedimentation Controls	1	LS	\$ 2,400.00	\$ 2,400.00
4.	Site Maintenance and Restoration	1	LS	\$ 7,900.00	\$ 7,900.00
Drainage					
5.	12-Inch HDPE Storm Sewer Pipe	150	LF	\$ 40.00	\$ 6,000.00
6.	24-Inch HDPE Storm Sewer Pipe	100	LF	\$ 50.00	\$ 5,000.00
7.	Storm Inlet 3-FT Diameter, Complete	2	EA	\$ 2,300.00	\$ 4,600.00
8.	24-inch Nyloplast Storm Structure	2	EA	\$ 2,000.00	\$ 4,000.00
9.	Bioretention Basin	1	EA	\$ 15,000.00	\$ 15,000.00
10.	6-Inch Underdrain	500	LF	\$ 10.00	\$ 5,000.00
Parking Lot Construction					
11.	Excavation Common	1,500	CY	\$ 20.00	\$ 30,000.00
12.	Excavation Below Subgrade (EBS)	75	CY	\$ 30.00	\$ 2,250.00
13.	4-Inch Thick Asphaltic Surface	1,700	SY	\$ 23.00	\$ 39,100.00
14.	Base Aggregate Dense 1 1/4 - Inch (8-Inch Depth)	1,700	SY	\$ 7.50	\$ 12,750.00
15.	Select Crushed Material (12-Inch Depth)	1,700	SY	\$ 10.00	\$ 17,000.00
16.	Geotextile Fabric Type SAS	1,700	SY	\$ 3.00	\$ 5,100.00
17.	6-Inch Thick Concrete Driveway /Sidewalk w/6-Inch Base	315	SF	\$ 7.00	\$ 2,205.00
18.	4-Inch Thick Concrete Sidewalk w/ 6-Inch Base	1,485	SF	\$ 6.00	\$ 8,910.00
Subtotal of Drainage and Parking Lot Construction					\$ 156,915.00
Base Bid					\$ 30,800.00
Total Improvements, Rounded					\$ 187,700.00
Contingencies (20%)					\$ 37,500.00
TOTAL CONSTRUCTION (Including Contingencies)					\$ 225,200.00
GEO TECHNICAL INVESTIGATIONS ALLOWANCE					\$ 3,500.00
DESIGN ENGINEERING					\$ 29,300.00
CONSTRUCTION ADMINISTRATION					\$ 3,400.00
CONSTRUCTION OBSERVATION					\$ 4,000.00
COST ESCALATION (INFLATION 3% per annum)					\$ 6,800.00
PROJECT TOTAL					\$ 272,200.00