

Madison Board of Education, Madison District #1

Board of Education Regular Meeting
Monday, May 11, 2020 7:00 PM
MS/HS Commons
700 South Kent St.
Madison, NE 68748-0450

The sequence of items on the agenda is provided as a courtesy. The board reserves the right to consider items in any sequence deemed appropriate. Therefore, visitors are encouraged to attend the meeting from the beginning.

1. Call the Meeting to Order
 1. Roll Call
 2. Pledge of Allegiance
 3. Open Meetings Act
 4. Madison Public Schools Mission Statement
2. Consent Agenda
3. Public Forum
4. Administrator and Other Reports
5. Board Committee Reports/Meeting dates
6. Action Items
 1. Discuss, consider, and take all necessary action to approve resignation.
 2. Discuss, consider, and take all necessary action to approve contracts.
 3. Discuss, consider, and take all necessary action to reaffirm Board policies 6023-6036.
 4. Discuss, consider, and take all necessary action on the Elementary student handbook for 2020-2021.
 5. Discuss, consider, and take all necessary action to approve the Little Dragons Childcare handbook for 2020-2021.
 6. Discuss, consider, and take all necessary action to approve the Middle School Language Arts Curriculum purchase.
 7. Discuss, consider, and take all necessary action on the purchase of technology devices to update the office staff work stations.
 8. Discuss, consider, and take all necessary action to purchase tables and chairs for the Middle School Commons.
 9. Discuss, consider, and take all necessary action on Speaker system donation sign design.
 10. Discuss, consider, and take all necessary action on a change orders to add additional safety rails on the the northwest mezzanine and to add popular wood to replace vinyl base along wheel chair ramp in MS commons.
7. Executive Session
 1. Discuss classified staff compensation and benefit package to protect the public interest and prevent needless injury to a staff member's reputation.
8. Any Action resulting from Executive Session.
 1. Discuss, consider, and take all necessary action on classified salaries and benefits for the 2020-2021 school year.
9. Topics for next month's Board of Education meeting

10. Adjournment

The board reserves the right to enter executive session if it deems it necessary to prevent needless injury to a staff member's reputation or for the protection of the public interest.

Madison Public Schools
05/01/2020 3:09 PM

Board Report
APRIL 2020 Activity Detail

Page: 1
User ID: PATTI

<u>Vendor Name</u>	<u>Invoice</u>	<u>Description</u>	<u>Amount</u>
Checking	5		
Checking	5	Fund: 05 ACTIVITY FUND	
BSN SPORTS, LLC	907760851	(2) helmets & (3) shoulder pads	2,073.32
Vendor Total:			2,073.32
CHOICE FOODS	002081231004	Supplies for NHS Induction Ceremony	35.98
CHOICE FOODS	002082011650	Supplies	6.30
CHOICE FOODS	002082721204	Supplies	6.25
Vendor Total:			48.53
CLASSIC SPORTSWEAR	62232	3 -Sport Chenille Letters	149.70
Vendor Total:			149.70
COOPER, JAMES	Memorial	Memorial - Father	25.00
Vendor Total:			25.00
CUSTOM SPORTS	27286	"We Are Madison" Sweatshirts & Hoodies	730.00
Vendor Total:			730.00
HELLER, SHARILYN	Memorial-Mother	Memorial - Mother	25.00
Vendor Total:			25.00
MAHASKA	921845	Beverages	79.60
Vendor Total:			79.60
MFAC, LLC (MF ATHLETIC)	112763	Safety Pins (cross country)	48.00
MFAC, LLC (MF ATHLETIC)	113022	Cross Country Kit	545.00
MFAC, LLC (MF ATHLETIC)	411-S0242645	Track supplies	385.82
Vendor Total:			978.82
MICHAEL'S PHOTOGRAPHY	28796	Senior Composites	340.00
Vendor Total:			340.00

Board Reports

Patti Reigle
Tue 5/5/2020 11:22 AM



To: Alan Ehlers

- April 2020.pdf
73 KB
- April 2020 Activity Detail.pdf
60 KB
- April 2020 Lunch Detail.pdf
59 KB

3 attachments (192 KB) Download all

Save all to OneDrive - esu8.org

April Board Reports

Patti Reigle, Administrative Assistant
Madison Public Schools

<u>Vendor Name</u>	<u>Invoice</u>	<u>Description</u>	<u>Amount</u>
Checking	06		
Checking	06	Fund: 06 SCHOOL NUTRITION FUND	
APPEARA	0520718	Mops & Aprons	46.00
APPEARA	0525081	Mops & Aprons	46.00
		Vendor Total:	92.00
CASH-WA DISTRIBUTING	12391749	Food	651.94
CASH-WA DISTRIBUTING	12411951	Food	2,161.41
CASH-WA DISTRIBUTING	CM2789548	Returned Food	(118.10)
		Vendor Total:	2,695.25
COMPUTER INFORMATION CONCEPTS	PS130595	RENEWAL-Food Service Software-12 months	1,096.00
		Vendor Total:	1,096.00
EARTHGRAINS BAKING CO. INC.	54330419573	Bread	149.50
EARTHGRAINS BAKING CO. INC.	54330419574	Bread	241.30
EARTHGRAINS BAKING CO. INC.	54330419774	Bread	56.20
EARTHGRAINS BAKING CO. INC.	54330419775	Bread	70.25
		Vendor Total:	517.25
EGAN SUPPLY CO.	315380	Supplies	671.22
		Vendor Total:	671.22
HILAND DAIRY FOODS	330338	Milk	168.14
HILAND DAIRY FOODS	330339	Milk	149.54
HILAND DAIRY FOODS	330383	Milk	290.87
HILAND DAIRY FOODS	330384	Milk	250.53
HILAND DAIRY FOODS	330424	Milk	130.25
HILAND DAIRY FOODS	330425	Milk	162.62
HILAND DAIRY FOODS	330511	Milk	248.62
HILAND DAIRY FOODS	330512	Milk	300.34
HILAND DAIRY FOODS	330576	Milk	166.00
HILAND DAIRY FOODS	330577	Milk	153.59
HILAND DAIRY FOODS	330609	Milk	106.29
HILAND DAIRY FOODS	330610	Milk	118.10
HILAND DAIRY FOODS	330611	Milk	13.50
HILAND DAIRY FOODS	330633	Milk	158.60
HILAND DAIRY FOODS	330635	Milk	205.84
HILAND DAIRY FOODS	330661	Milk	41.63
HILAND DAIRY FOODS	330662	Milk	41.63
HILAND DAIRY FOODS	330663	Milk	23.62
		Vendor Total:	2,729.71
MAJOR REFRIGERATION	IC04442	Repairs on 2-door refrigerator-EL	177.20
		Vendor Total:	177.20
MPS GENERAL FUND	March 2020 Hours	March 2020 Kitchen Salary & Benefits	17,552.78
		Vendor Total:	17,552.78
SYSCO LINCOLN	361011943	Food & Paper Products	1,568.66
SYSCO LINCOLN	361011944	Food & Paper Products	1,632.09
SYSCO LINCOLN	361035265	Food & Paper Products	937.40
SYSCO LINCOLN	361035266	Food & Paper Products	430.73
SYSCO LINCOLN	361042137	Food & Paper Products	584.23

<u>Vendor Name</u>	<u>Invoice</u>	<u>Description</u>	<u>Amount</u>
SYSCO LINCOLN	361052237	Food & Paper Products	1,005.18
SYSCO LINCOLN	361052238	Food & Paper Products	986.13
SYSCO LINCOLN	CM361037464	Return	(40.35)
		Vendor Total:	7,104.07
US FOODS, INC.	3818269	Commodities	840.07
US FOODS, INC.	3818270	Commodities	965.68
US FOODS, INC.	4068833	Commodities	908.78
US FOODS, INC.	4068834	Commodities	1,092.65
US FOODS, INC.	4068835	Commodities	911.87
US FOODS, INC.	4068836	Commodities	985.53
		Vendor Total:	5,704.58
		Fund Total:	38,340.06
		Checking Account Total:	38,340.06

MADISON PUBLIC SCHOOLS					
Activity Fund Balance Report					
APRIL 2020		Fund 05			
<u>Chart of Account Description</u>	<u>Beg Balance</u>	<u>Expenses</u>	<u>Revenues</u>	<u>Bal Change</u>	<u>Balance</u>
FUND BALANCE	0.00	0.00	0.00	0.00	0.00
AD	9,803.06	3,551.14	0.00	0.00	6,251.92
Art Club	516.24	0.00	0.00	0.00	516.24
Band	4,328.55	0.00	0.00	0.00	4,328.55
Boys BB	1,447.51	95.97	234.88	0.00	1,586.42
Boys BB FR	486.91	0.00	0.00	0.00	486.91
Cheerleaders	72.69	0.00	0.00	0.00	72.69
Class of 2019	635.43	0.00	0.00	0.00	635.43
Class of 2020	1,705.22	340.00	580.00	0.00	1,945.22
Class of 2021	2,753.97	0.00	0.00	0.00	2,753.97
Class of 2022	828.22	0.00	0.00	0.00	828.22
Class of 2023	190.00	0.00	0.00	0.00	190.00
Concessions	14,774.76	147.05	0.00	0.00	14,627.71
Courtesy	2,677.45	74.50	0.00	0.00	2,602.95
Cross Country	32.04	0.00	0.00	0.00	32.04
Cross Country FR	1,054.61	0.00	0.00	0.00	1,054.61
Danceline	400.26	0.00	0.00	0.00	400.26
District Funds	11,140.77	0.00	134.49	0.00	11,275.26
Educators Rising	867.28	0.00	0.00	0.00	867.28
Elem Activity Acct	2,220.42	315.75	355.75	0.00	2,260.42
Elem PTO	1,684.47	0.00	0.00	0.00	1,684.47
Elem Student Council	47.00	0.00	0.00	0.00	47.00
ELL Class	630.75	0.00	0.00	0.00	630.75
Emergency Assistance	1,533.24	0.00	0.00	0.00	1,533.24
Ethnic Diversity Club	1,740.53	0.00	0.00	0.00	1,740.53
FCCLA	307.83	0.00	0.00	0.00	307.83
FFA	4,734.94	64.00	130.00	0.00	4,800.94
Football	2,111.05	0.00	0.00	0.00	2,111.05
Football FR	465.71	0.00	0.00	0.00	465.71
Football Youth	250.00	0.00	0.00	0.00	250.00
Girls BB	1,366.48	0.00	0.00	0.00	1,366.48
Girls BB FR	507.66	0.00	0.00	0.00	507.66
Golf	603.76	(300.00)	0.00	0.00	903.76
Golf FR	192.35	0.00	0.00	0.00	192.35
Homecoming	1,153.22	0.00	0.00	0.00	1,153.22
Honor Society	1,299.34	422.77	0.00	0.00	876.57
HS Student Council	1,540.15	126.00	0.00	0.00	1,414.15
M Club	5,102.38	149.70	0.00	0.00	4,952.68
Marketing Comm.	17,422.19	0.00	0.00	0.00	17,422.19
MS Activity Acct	4,005.32	0.00	0.00	0.00	4,005.32
MS Houses	665.94	0.00	0.00	0.00	665.94

Lunch Fund Balance Report					
APRIL 2020		Fund 06			
<u>Chart of Account Description</u>	<u>Beg Balance</u>	<u>Expenses</u>	<u>Revenues</u>	<u>Bal Change</u>	<u>Balance</u>
FUND BALANCE	47,156.06	38,340.06	25,809.22	0.00	34,625.22
					FUND 06

Student Fund Balance Report					
APRIL 2020		Fund 12			
<u>Chart of Account Description</u>	<u>Beg Balance</u>	<u>Expenses</u>	<u>Revenues</u>	<u>Bal Change</u>	<u>Balance</u>
FUND BALANCE	6,444.55	0.00	0.53	0.00	6,445.08
					<u>FUND 12</u>

Kate Ebeling: Present, Harlow Hanson: Present, Jim Knapp: Present, Deb Neidig, Present, Jim Reeves: Present, Steve Ruh: Present. Present: 6

1: Call the meeting to order

Motion to call the meeting to order at 7:00 pm. Passed with a motion by Kate Ebeling and a second by Jim Knapp. Kate Ebeling: Yea, Harlow Hanson: Yea, Jim Knapp: Yea, Deb Neidig: Yea, Jim Reeves: Yea, Steve Ruh: Yea. Yea: 6, Nay: 0

- 1.1 Roll Call
- 1.2 Pledge of Allegiance
- 1.3 Open Meetings Act
- 1.4 Madison Public Schools Mission Statement

2: Consent Agenda

Motion to approve consent agenda items 2.1, 2.2 & 2.3 as presented. Passed with a motion by Steve Ruh and a second by Jim Knapp. Kate Ebeling: Yea, Harlow Hanson: Yea, Jim Knapp: Yea, Deb Neidig: Yea, Jim Reeves: Yea, Steve Ruh: Yea. Yea: 6, Nay: 0

A to Z Vac N Sew	Supplies	44.85
A&H Building Supply, Inc.	Supplies	16.00
Albracht Disposal Service	Waste Disposal	325.00
Amazon.Com Credit	Supplies	5,247.91
Appearra	Supplies	193.62
Apple Computer, Inc.	Supplies/Computer Repairs	1,430.00
Assetgenier, Inc. DBA Agirepair	Computer Repair	100.00
BCN	Telephone Services	290.99
Big Country Auto	Maintenance	1,667.70
Brady & Amy's	Fuel	66.86
Brandl Electric	Maintenance	31.20
Centerpoint Energy Services	Utilities	4,443.58
Central Nebraska Rehab Services	Contracted Services	3,392.68
Choice Foods	Fuel/Supplies	908.67
City of Madison	Utilities	7,966.37
Colonial Research Chemical	Supplies	1,208.80
Commonwealth Electric Company	Maintenance	5,465.00
Demco	Supplies	112.93
Dent Specialists	Snow Removal/Maintenance	945.00
Eakes Office Solutions	Supplies	76.56
Ecolab Pest Elimination Division	Pest control	81.85
Educational Service Unit #8	SpEd Services	41,634.30
Eller Heating & Air Conditioning	Repairs	1,795.81
Federal Express Corporation	Shipping	164.07
Field's Hardware	Supplies	78.74
Flinn Scientific, Inc.	Supplies	430.60
Floor Maintenance	Supplies	28.17
Frontier	Phone Service	689.02
Ganskow, Troy	Reimbursement	7.50
Great Financial Services Corporation	Copier Lease	6,579.45
GT Fire & Security, Inc.	Inspection	150.00
Harris	Software Renewal	738.66
Hireright LLC, Inc.	Testing	31.40
Jackson Services	Supplies	97.15

Ken's Band Instrument Repair	Instrument Repair	62.00
KSB School Law	Legal Services	2,195.50
Lakeshore Learning Materials	Supplies	236.20
M & O Door Products	Repairs	82.00
Madison Star Mail	Publications	281.84
Mid-American Research Chemical	Supplies	834.20
McGraw-Hill Education Book Company	Textbooks	8,056.41
Menards-Norfolk	Supplies/Maintenance/Repairs	1,507.63
Midwest Alarm Services	Contracted/Alarm Services	737.36
Miller Fitness & Performance	Supplies	35.00
MPS Activity Fund	Reimbursement	64.00
MPS Lunch Fund	Supplies	156.01
NE Regional Deaf Ed Program	Services	380.00
Nebraska Public Health Environmental Lab	Water Testing	17.00
Norfolk Area Shopper	Advertisement	203.00
Norfolk Daily News	Advertisement	456.64
O'Keefe Elevator Co., Inc.	Elevator Maintenance	311.84
Pitney Bowes	Postage	117.00
Quill Corporation	Supplies	290.50
RS Electric	Maintenance/Repairs	4,041.56
Sherwin Williams Co	Supplies	166.20
Short Stop, The	Fuel	36.75
Sparklight (Formerly Cable One)	Cable Box Rental	27.02
US Bank Cardmember Services	Supplies	4,894.92
Volkman Plumbing & Heating	Repairs	390.42
Walmart Community	Supplies	362.13
Water Engineering Inc.	Water Service	425.04

3: Public forum

4: Administrator and other reports

5: Board Committee Reports/Meeting dates

6: Action Items

7: Discuss, consider and take all necessary action to reaffirm Board policies 6001-6021.

Motion to reaffirm Board policies 6001-6021. Passed with a motion by Jim Reeves and a second by Jim Knapp. Kate Ebeling: Yea, Harlow Hanson: Yea, Jim Knapp: Yea, Deb Neidig: Yea, Jim Reeves: Yea, Steve Ruh: Yea. Yea: 6, Nay: 0

8: Discuss, consider and take all necessary action to approve resignations.

9: Discuss, consider, and take all necessary action to approve teacher and administrative contracts.

Motion to approve teaching and administrative contracts. Passed with a motion by Deb Neidig and a second by Kate Ebeling. Kate Ebeling: Yea, Harlow Hanson: Yea, Jim Knapp: Yea, Deb Neidig: Yea, Jim Reeves: Yea, Steve Ruh: Yea. Yea: 6, Nay: 0

10: Discuss, consider, and take all necessary action on a Food Service Agreement with Lunch Time Solutions.

Motion to approve a contract agreement with Lunch Time Solutions to provide food service to Madison Public Schools. Passed with a motion by Kate Ebeling and a second by Steve Ruh. Kate Ebeling: Yea, Harlow Hanson: Yea, Jim Knapp: Yea, Deb Neidig: Yea, Jim Reeves: Yea, Steve Ruh: Yea. Yea: 6, Nay: 0

11: Discuss, consider, and take all necessary action to adopt a resolution with the Lower Elkhorn Natural Resources District Multi-Jurisdictional Hazard Mitigation Plan.

Motion to approve the resolution with the Lower Elkhorn Natural Resources District. Passed with a motion by Jim Knapp and a second by Kate Ebeling. Kate Ebeling: Yea, Harlow Hanson: Yea, Jim Knapp: Yea, Deb Neidig: Yea, Jim Reeves: Yea, Steve Ruh: Yea. Yea: 6, Nay: 0

12: Discuss, consider, and take all necessary action to approve a resolution on grades, graduation, curriculum, and related matters.

Motion to approve Resolution A for the 2020-2021 school year. Passed with a motion by Deb Neidig and a second by Jim Reeves. Passed with a motion by Kate Ebeling and a second by Jim Knapp. Kate Ebeling: Yea, Harlow Hanson: Yea, Jim Knapp: Yea, Deb Neidig: Yea, Jim Reeves: Yea, Steve Ruh: Yea. Yea: 6, Nay: 0

13: Discuss, consider, and take all necessary action on the 2020-2021 MS/HS student handbooks.

Motion to approve the MS/HS handbooks with suggested changes.. Passed with a motion by Steve Ruh and a second by Harlow Hanson. Kate Ebeling: Yea, Harlow Hanson: Yea, Jim Knapp: Yea, Deb Neidig: Yea, Jim Reeves: Yea, Steve Ruh: Yea. Yea: 6, Nay: 0

14: Discuss, consider, and take all necessary action to sell surplus school items.

Motion to sell surplus school items in June. Passed with a motion by Steve Ruh and a second by Jim Reeves. Kate Ebeling: Yea, Harlow Hanson: Yea, Jim Knapp: Yea, Deb Neidig: Yea, Jim Reeves: Yea, Steve Ruh: Yea. Yea: 6, Nay: 0

15: Discuss, consider, and take all necessary action to approve administrative contract increases for the 2020-2021 school year.

Motion to approve administrative salary increases of \$3,500.00 plus \$500.00 additional to live in the school district. Passed with a motion by Jim Reeves and a second by Kate Ebeling. Kate Ebeling: Yea, Harlow Hanson: Yea, Jim Knapp: Yea, Deb Neidig: Yea, Jim Reeves: Yea, Steve Ruh: Yea. Yea: 6, Nay: 0

16: Discuss, consider, and take all necessary action to approve extra duty coaches and sponsors.

Motion to approve extra duty assignments. Passed with a motion by Jim Knapp and a second by Jim Reeves. Kate Ebeling: Yea, Harlow Hanson: Yea, Jim Knapp: Yea, Deb Neidig: Yea, Jim Reeves: Yea, Steve Ruh: Yea. Yea: 6, Nay: 0

17: Discuss, consider, and take all necessary action on floor covering for the middle school commons.

Motion to approve a change order to install Bolder at the increased price of \$2,798.00. Passed with a motion by Jim Reeves and a second by Kate Ebeling. Kate Ebeling: Yea, Harlow Hanson: Yea, Jim Knapp: Yea, Deb Neidig: Yea, Jim Reeves: Yea, Steve Ruh: Yea. Yea: 6, Nay: 0

18: Discuss, consider, and take all necessary action to increase lunch prices by ten cents per meal at all grade levels and for adults.

Motion to increase meal prices by 10 cents for the 2020-2021 school year at all grade levels and for adults. Passed with a motion by Steve Ruh and a second by Harlow Hanson. Kate Ebeling: Yea, Harlow Hanson: Yea, Jim Knapp: Yea, Deb Neidig: Yea, Jim Reeves: Yea, Steve Ruh: Yea. Yea: 6, Nay: 0

19: Topics for next month's Board of Education meeting.

20: Adjournment

Motion to adjourn at 9:02 PM. Passed with a motion by Deb Neidig and a second by Kate Ebeling. Kate Ebeling: Yea, Harlow Hanson: Yea, Jim Knapp: Yea, Deb Neidig: Yea, Jim Reeves: Yea, Steve Ruh: Yea. Yea: 6, Nay: 0

President

Secretary

**MADISON PUBLIC SCHOOLS
TREASURER'S REPORT**

April 30, 2020

General Fund

BALANCE

Last year's balance

Balance Forward as of	<u>March 31, 2020</u>				\$2,544,155.02	
Receipts		+	\$	457,141.41		
Expenditures		-	\$	581,070.59		
Balance as of	<u>April 30, 2020</u>				\$2,420,225.84	\$1,788,629.62

Employee Benefit Fund

Balance Forward as of	<u>March 31, 2020</u>				\$10,304.81	
Receipts		+	\$	2,720.02		
Expenditures		-	\$	1,681.38		
Balance as of	<u>April 30, 2020</u>				\$11,343.45	\$13,004.96

Petty Cash Fund

Balance Forward as of	<u>March 31, 2020</u>				\$2,451.06	
Receipts		+	\$	2,274.79		
Expenditures		-	\$	2,274.56		
Balance as of	<u>April 30, 2020</u>				\$2,451.29	\$2,465.86

Total Assets for General Fund

\$2,434,020.58 \$1,804,100.44

Depreciation Fund

Balance Forward as of	<u>March 31, 2020</u>				\$722,890.39	
Receipts		+	\$	592.53		
Expenditures		-				
Balance as of	<u>April 30, 2020</u>				\$723,482.92	\$840,048.96

Bond Fund

Balance Forward as of	<u>March 31, 2020</u>				\$120,453.65	
Receipts		+	\$	1,661.14		
Expenditures		-				
Balance as of	<u>April 30, 2020</u>				\$122,114.79	\$168,898.30

Qualified Capital Purpose Fund

Balance Forward as of	<u>March 31, 2020</u>				\$487,154.19	
Receipts		+	\$	1,004.25		
Expenditures		-				
Balance as of	<u>April 30, 2020</u>				\$488,158.44	\$427,115.67

Special Building Fund

Balance Forward as of	<u>March 31, 2020</u>				\$2,523,522.36	
Receipts		+	\$	8,344.30		
Expenditures		-	\$	122,124.20		
Balance as of	<u>April 30, 2020</u>				\$2,409,742.46	\$5,848,135.61

Investment Checking

Balance Forward as of	<u>March 31, 2020</u>				\$324,069.01	
Receipts		+	\$	265.63		
Expenditures		-	\$	-		
Balance as of	<u>April 30, 2020</u>				\$324,334.64	\$318,161.47

LINE #	DESCRIPTION	BUDGET	General Fund Receipts	
			CURRENT RECEIPTS	
	TOTAL LOCAL	\$5,677,613	\$3,220,396	
	TOTAL STATE	\$662,273	\$400,199	
	TOTAL FEDERAL	\$414,249	\$499,695	
3500	Education Quest	\$0	\$2,989	
3512	Distance Learning	\$0	\$845	
3535	High Ability Learners	\$0	\$4,358	
4105	Erate	\$0	\$5,594	
4505	Title I	\$0	\$27,080	
4506	Title I Part A	\$0	\$5,038	
4507	SIG Middle School	\$0	\$54,314	
4508	Title ID Delinquent Ed.	\$0	\$25,201	
4509	Title IIA, Educator Quality	\$0	\$18,885	
4510	Title IV Part A	\$0	\$2,245	
4512	IDEA Base	\$0	\$40,871	
4516	IDEA Base P/S	\$0	\$1,056	
4519	IDEA Enrollment Poverty	\$0	\$68,544	
4521	Idea Prop Share	\$0	\$21,989	
4525	Perkins	\$0	\$6,749	
4526	Title IC Migrant Education	\$0	\$91,419	
4531	21st Century ASP	\$0	\$10,327	
4310	REAP	\$0	\$32,500	
4708	Medicaid in Public Schools	\$0	\$4,499	
4709	Neb-Mac Funds	\$0	\$7,965	
5400	NON-REVENUE SOURCES (SOP)	\$0	\$1,378	
6212	Title Support for Improvements		\$65,848	
			BUDGET OF EXPENDITURES	
			ESTIMATED	
		CURRENT BUDGET	CURRENT SPENDING	% Remaining
1100	REGULAR EDUCATION	\$4,275,000.00	\$2,355,513	45%
1200	SPECIAL EDUCATION	\$830,000	\$608,152	27%
2100/2150	SUPPORT SERVICES - PUPILS	\$390,000	\$230,499	41%
2200	SUPPORT SERVICES - STAFF	\$180,000	\$123,836	31%
2310	BOARD OF EDUCATION	\$68,000	\$31,617	54%
2320	EXECUTIVE ADMINISTRATION	\$200,000	\$129,789	35%
2330	DISTRICT LEGAL SERVICES	\$25,000	\$12,099	52%
2410	OFFICE OF THE PRINCIPAL	\$475,000	\$182,608	62%
2510	GENERAL ADMINISTRATION/BS	\$300,000	\$121,864	59%
2610	MAIN. & OPERATION OF BLDS.	\$1,046,000	\$336,206	68%
2710	REGULAR TRANSPORTATION	\$128,000	\$68,982	46%
2712	SCHOOL AGE SPED TRAN.	\$20,000	\$10,367	48%
3535	HIGH ABILITY LEARNERS	\$2,500	\$2,033	19%
6000	FEDERAL PROGRAMS	\$1,047,500	\$497,468	53%
8000	TRANSFER TO DEPRECIATION	\$0		
8000	TRANSFER TO ATHLETICS/LUNCH	\$0		
8000	TRANSFER TO OTHERS	\$38,000		100%
	BUDGET GROWTH	\$200,000.00		100%
	TOTAL BUDGET	\$9,025,000	\$4,711,033	48%

<u>Vendor Name</u>	<u>Invoice</u>	<u>Description</u>	<u>Amount</u>	
Checking	1			
Checking	1	Fund: 01 GENERAL FUND		
A TO Z VAC.N.SEW	0420 STMT	REPAIRS	109.85	
		Vendor Total:		109.85
ACADIENCE DYNAMIC MEASUREMENT GROUP	25987	SERVICES	254.00	
		Vendor Total:		254.00
ALBRACHT DISPOSAL SERVICE	12644	WASTE DISPOSAL	155.00	
ALBRACHT DISPOSAL SERVICE	12645	WASTE DISPOSAL	170.00	
		Vendor Total:		325.00
ALPHA WORKFORCE HEALTH	11332	DOT PHYSICAL	80.00	
		Vendor Total:		80.00
AMAZON.COM CREDIT	434444345993	SUPPLIES	44.99	
AMAZON.COM CREDIT	445654686578	SUPPLIES	8.78	
AMAZON.COM CREDIT	448473334576	SUPPLIES	25.67	
AMAZON.COM CREDIT	453779893797	SUPPLIES	96.97	
AMAZON.COM CREDIT	456385788396	SUPPLIES	108.12	
AMAZON.COM CREDIT	457936659377	SUPPLIES	83.14	
AMAZON.COM CREDIT	458489745535	SUPPLIES	8.51	
AMAZON.COM CREDIT	459583879957	SUPPLIES	14.98	
AMAZON.COM CREDIT	468653566884	SUPPLIES	10.67	
AMAZON.COM CREDIT	473489457494	SUPPLIES	91.29	
AMAZON.COM CREDIT	489456487354	SUPLIES	(39.99)	
AMAZON.COM CREDIT	5685853974346	SUPPLIES	79.99	
AMAZON.COM CREDIT	584583538948	SUPPLIES	66.90	
AMAZON.COM CREDIT	685734673469	SUPPLIES	199.86	
AMAZON.COM CREDIT	695876394554	SUPPLIES	86.53	
AMAZON.COM CREDIT	754555693686	SUPPLIES	328.44	
AMAZON.COM CREDIT	798374657864	SUPPLIES	11.99	
AMAZON.COM CREDIT	955864687385	SUPPLIES	79.90	
AMAZON.COM CREDIT	977458953779	SUPPLIES	70.80	
AMAZON.COM CREDIT	987353364865	SUPPLIES	75.59	
AMAZON.COM CREDIT	998386777933	SUPPLIES	67.00	
		Vendor Total:		1,520.13
APPLE COMPUTER, INC.	AB44683082	SUPPLIES	1,249.00	
		Vendor Total:		1,249.00
APPLE, INC	AC02317484	COMPUTER REPAIRS	49.00	
		Vendor Total:		49.00
ASSETGENIE, INC DBA AGIREPAIR	1468421	COMPUTER REPAIRS	249.00	
ASSETGENIE, INC DBA AGIREPAIR	1468448	COMPUTER REPAIRS	234.00	
		Vendor Total:		483.00
AUTOMATED DAIRY SPECIALISTS, LLC	20-5991	SUPPLIES	195.00	
		Vendor Total:		195.00
BATTLE CREEK PUBLIC SCHOOLS	0420 STMT	SERVICES	2,805.00	
		Vendor Total:		2,805.00
BIG COUNTRY AUTO	68373	REPAIRS & MAINTENANCE	88.42	

<u>Vendor Name</u>	<u>Invoice</u>	<u>Description</u>	<u>Amount</u>	
BIG COUNTRY AUTO	68380	REPAIRS & MAINTENANCE	321.65	
BIG COUNTRY AUTO	68387	REPAIRS & MAINTENANCE	47.70	
BIG COUNTRY AUTO	68403	REPAIRS & MAINTENANCE	48.70	
BIG COUNTRY AUTO	68411	REPAIRS & MAINTENANCE	47.70	
BIG COUNTRY AUTO	68413	REPAIRS & MAINTENANCE	47.70	
BIG COUNTRY AUTO	68422	REPAIRS & MAINTENANCE	225.00	
BIG COUNTRY AUTO	68476	REPAIRS & MAINTENANCE	357.47	
		Vendor Total:		1,184.34
BRADY & AMY'S	51162	FUEL	84.87	
		Vendor Total:		84.87
CAROLINA SCIENTIFIC	51014386 RI	SUPPLIES	98.80	
		Vendor Total:		98.80
CENTRAL NEBRASKA REHAB SERVICES	0320 STMT	SERVICES	5,269.62	
		Vendor Total:		5,269.62
CHOICE FOODS	001030371429	SUPPLIES	39.90	
CHOICE FOODS	00103417056	SUPPLIES	13.63	
		Vendor Total:		53.53
CITY OF MADISON	50400 0420 STMT	UTILITIES	1,345.06	
CITY OF MADISON	50670 0420 STMT	UTILITIES	34.92	
CITY OF MADISON	50675 0420 STMT	UTILITIES	262.50	
CITY OF MADISON	70650 0420 STMT	UTILITIES	1,777.71	
CITY OF MADISON	70700 0420 STMT	UTILITIES	3,694.86	
		Vendor Total:		7,115.05
COGNIA INC	00128999	ACCREDITATION FEES	3,600.00	
		Vendor Total:		3,600.00
COLONIAL RESEARCH CHEMICAL	145202	SUPPLIES	125.40	
		Vendor Total:		125.40
COMPUTER INFORMATION CONCEPTS	PSI30595	SOFTWARE RENEWAL	6,260.00	
		Vendor Total:		6,260.00
CURRICULUM ASSOCIATES LLC	90639768	SUPPLIES	301.95	
		Vendor Total:		301.95
DENT SPECIALISTS	129570	REPAIRS	294.04	
		Vendor Total:		294.04
DUERST, BRANDON	1717	LAWN CARE	2,500.00	
		Vendor Total:		2,500.00
EAKES OFFICE SOLUTIONS	8002878-0	REPAIRS & MAINTENANCE	30.00	
		Vendor Total:		30.00
ECOLAB PEST ELIMINATION DIVISION	9094513	PEST CONTROL	81.85	
		Vendor Total:		81.85
EDUCATIONAL SERVICE UNIT #8	INV-006362	SPED SERVICES	20,584.05	
EDUCATIONAL SERVICE UNIT #8	INV-006381	SPED SERVICES	17,200.00	
EDUCATIONAL SERVICE UNIT #8	INV-006396	SPED SERVICES	1,117.20	

<u>Vendor Name</u>	<u>Invoice</u>	<u>Description</u>	<u>Amount</u>	
			Vendor Total:	38,901.25
EGAN SUPPLY CO.	318588	SUPPLIES	2,086.07	
			Vendor Total:	2,086.07
FEDERAL EXPRESS CORPORATION	6-981-86880	SHIPPING	40.88	
			Vendor Total:	40.88
FIELDS HARDWARE	0420 STMT	SUPPLIES	139.73	
			Vendor Total:	139.73
FLINN SCIENTIFIC, INC.	2468145	SUPPLIES	202.78	
			Vendor Total:	202.78
FLOOR MAINTENANCE	Web-5197	SUPPLIES	117.27	
			Vendor Total:	117.27
FRONTIER	0420 STMT	PHONE SERVICE	692.75	
			Vendor Total:	692.75
GOPHER SPORTS EQUIPMENT	9710399	SUPPLIES	174.15	
			Vendor Total:	174.15
GREATAMERICA FINANCIAL SERVICES CORPORATION	26931465	COPIER LEASE	2,890.41	
			Vendor Total:	2,890.41
HIRERIGHT LLC, INC	P0952780	TESTING	62.80	
			Vendor Total:	62.80
INSTRUMENTALIST AWARDS LLC	2001	SUPPLIES	93.50	
			Vendor Total:	93.50
JACKSON SERVICES	4285634	SUPPLIES	40.00	
JACKSON SERVICES	4295887	SUPPLIES	56.37	
JACKSON SERVICES	4295888	SUPPLIES	40.78	
			Vendor Total:	137.15
KSB SCHOOL LAW	7921	LEGAL SERVICES	670.50	
			Vendor Total:	670.50
MCGRAW-HILL EDUCATION BOOK COMPANY	11261335002	TEXTBOOKS	3,723.47	
MCGRAW-HILL EDUCATION BOOK COMPANY	112613835001	SUPPLIES	5,224.11	
MCGRAW-HILL EDUCATION BOOK COMPANY	1126800132001	SUPPLIES	1,328.87	
MCGRAW-HILL EDUCATION BOOK COMPANY	112682517001	SUPPLIES	247.05	
			Vendor Total:	10,523.50
MENARDS - NORFOLK	83615	SUPPLIES	59.65	
MENARDS - NORFOLK	83983	SUPPLIES	159.62	
MENARDS - NORFOLK	84224	SUPPLIES	277.77	
MENARDS - NORFOLK	84683	SUPPLIES	202.32	
MENARDS - NORFOLK	84825	SUPPLIES	72.47	
			Vendor Total:	771.83
MIDWEST ALARM SERVICES	319945	CONTRACTED SERVICES	336.00	
			Vendor Total:	336.00

<u>Vendor Name</u>	<u>Invoice</u>	<u>Description</u>	<u>Amount</u>	
MPS LUNCH FUND	200595	SUPPLIES	178.25	
		Vendor Total:		178.25
NASCO ARTS & CRAFTS	815728	SUPPLIES	145.38	
		Vendor Total:		145.38
NATIONAL ASSOCIATION OF SCHOOL NURSES	1034800	MEMBERSHIP	250.00	
		Vendor Total:		250.00
NE REGIONAL DEAF ED PROGRAM	0420 STMT	SERVICES	494.00	
		Vendor Total:		494.00
NEBRASKA PUBLIC HEALTH ENVIRONMENTAL LABORATORY	525066	WATER TESTING	30.00	
		Vendor Total:		30.00
NEBRASKA SAFETY CENTER PUPIL TRANSPORTATION	57-7469BUS	REGISTRATION	225.00	
		Vendor Total:		225.00
NORTHEAST NEBRASKA JUVENILE SERVICES	0320 STMT	REIMBURSEMENT	5,469.41	
NORTHEAST NEBRASKA JUVENILE SERVICES	0420 STMT	REIMBURSEMENT	5,469.40	
		Vendor Total:		10,938.81
PAPER 101	179153-00	SUPPLIES	4,520.00	
		Vendor Total:		4,520.00
REALLY GOOD STUFF	7209448	SUPPLIES	213.36	
REALLY GOOD STUFF	7209451	SUPPLIES	177.16	
		Vendor Total:		390.52
REIGLE IMPLEMENT CO., INC.	23179	SUPPLIES	302.49	
		Vendor Total:		302.49
SPARKLIGHT (FORMERLY CABLE ONE)	0420 STMT	CABLE BOX RENTAL	27.02	
		Vendor Total:		27.02
TEACHER SYNERGY, LLC (TPT)	116195247	SUPPLIES	52.99	
		Vendor Total:		52.99
TRUCK CENTER COMPANIES, FREIGHTLINER	374600	REPAIRS & MAINTENANCE	673.79	
		Vendor Total:		673.79
UNITED ART & EDUCATION	6574428	SUPPLIES	823.13	
		Vendor Total:		823.13
US BANK CARDMEMBER SERVICES	0420 STMT	SUPPLIES	714.56	
		Vendor Total:		714.56
WARDS SCIENCE	8089770349	SUPPLIES	123.72	
		Vendor Total:		123.72
WATER ENGINEERING INC	IN53067	WATER SERVICE	175.00	
WATER ENGINEERING INC	IN53078	WATER SERVICE	250.04	

<u>Vendor Name</u>	<u>Invoice</u>	<u>Description</u>	<u>Amount</u>
		Vendor Total:	425.04
		Fund Total:	112,224.70
		Checking Account Total:	112,224.70

September Board Meeting

Depreciation fund

McGraw Hill-\$7,287.93

Special Building fund

Fakler Architects-\$2,369.36

Mid-States Engineering & Testing-\$205.00

DWB, INC.-\$155,226.05

DWB, INC.-\$130,491.05

DWB, INC.-\$11,804.46

October Board Meeting

Depreciation fund

McGraw Hill-\$3765.85

DWB, Inc.-\$14,952.05

Special Building fund

DWB, Inc.-\$618,324.91

DWB, Inc.-\$139,772.40

Fakler Architects, LLC-\$508.08

November Board Meeting

Bond fund

BOK Financial-\$189,460.00

Special Building fund

DWB, Inc.-\$19,237.50

DWB, Inc.-\$187,756.19

DWB, Inc.-\$113,738.78

Fakler Architects, LLC-\$169.36

Mid-State Engineering & Testing-\$843.00

December Board Meeting

Depreciation fund

DWB, INC.-\$23,962.80

Special Building fund

MidState Engineering & Testing-\$889.00

Five Points Bank-\$678,554.37

DWB, INC.-\$250,070.96

DWB, INC.-\$83,411.61

Fakler Architects-\$169.36

January Board Meeting

Special Building Fund

DWB, Inc. - \$75,245.35 (MS Commons)

DWB, Inc. - \$132,185.85 (MHS Gym and Locker Room)

Mid State - \$710.00

Fakler Architects - \$6,419.36

Daktronics - \$91,626.00

Depreciation Fund

DWB, Inc. - \$32,427.30 (Bus Drop Off, Paving)

QCP Fund

Wells Fargo - \$1,002.58

February Board Meeting

Special Building Fund

DWB, Inc. - \$74,664.30 (MS Commons)
Mid State - \$1,574.50
Fakler Architects - \$6,419.36
DWB, Inc. - \$191,223.69 (MHS Gym and Locker Room)

March Board Meeting

Special Building fund

DWB, Inc. - \$68,160.15 (MS Commons)
DWB, Inc. - \$185,180.67 (MHS Gym and Locker Room)
Fakler Architechts - \$6,419.36

QCP Fund

BOK Financial - \$766.47

April Board Meeting

Special Building fund

DWB, Inc. \$82,096.98 MHS Gym and Locker Room
DWB, Inc. \$33,607.86 MS Commons
Fakler Architechts \$6,419.36

May Board Meeting

Special Building fund

Fakler Architects \$6,419.36
DWB, Inc. \$116,071.15 MHS Gym and Locker Room
DWB, Inc. \$145,126.12 MS Commons

Bond Fund

BOK Financial \$17,760.00

April Approved Bills

Current Financial Position for Phase IV Project

Special Building Fund	Current Funds	Estimate Cost or Goal	Actual Cost
Project/requirement			
Gym and Locker rooms	\$3,912,547.00	\$3,592,191.00	\$2,597,487.47
Middle School Addition	\$1,757,203.00	\$1,678,133.00	\$1,311,154.07
Sprinklers	\$107,358.00	\$107,358.00	\$49,272.32
Lease Repayment	\$200,000.00		\$824,201.60
Working Capital	\$0.00		
Balance as of November 2018	\$5,869,750.00		
Total		\$5,377,682.00	\$4,782,115.46
Depreciation Fund			
Concrete Replacement	\$928,244.00	\$339,071.00	\$87,120.70
Bus Drop Off	\$3,231.00	\$3,231.00	\$87,120.70
Total		\$342,302.00	\$87,120.70

APPLICATION FOR PAYMENT

CAP702
Page: 1 of 3

To:

Madison Public Schools
PO Box 450
Madison, NE 68748

PROJECT:

MHS GYM & LOCKER RM
Madison High Gym & Lockers Addition
Madison, NE

From Contractor:

dwb, inc.
PO Box 626
Madison, NE 68748

VIA ARCHITECT:

Fakler Architects
1001 N 6th St
Beatrice, NE 68310

CONTRACT FOR: MHS (Gym & Locker Room)

Application No.: Application Date: Period To: Contract Date:
15 APR 30, 2020 APR 30, 2020 DEC 18, 2018

Project Nos:

Distribution List: Owner Construction Mgr
 Architect Field
 Contractor Other

Contractor's Application for Payment

Application is made for payment as shown below, with attached Continuation Sheet.

1. Original Contract Amount: \$ 3,592,191.00
2. Net of Change Orders: \$ 59,811.18
3. Net Amount of Contract: \$ 3,652,002.18
4. Total Completed & Stored to Date: \$ 2,784,639.21
5. Retainage Summary:
 - a. 5.00 % of Completed Work \$ 133,691.17
 - b. 5.00 % of Stored Material \$ 5,540.80

- Total Retainage: \$ 139,231.97
6. Total Completed Less Retainage: \$ 2,645,407.24
7. Less Previous Applications: \$ 2,529,336.09

8. Current Payment Due, This Application: \$ 116,071.15

9. Contract Balance (Including Retainage): \$ 1,006,594.94

CHANGE ORDER Activity	Additions	Subtractions
Total previously approved:	59,811.18	0.00
Total approved this Month:	0.00	0.00
Sub Totals:	59,811.18	0.00
NET of Change Orders:	59,811.18	

CONTRACTOR'S CERTIFICATION:

The Contractor's signature here certifies that, to the best of their knowledge, this document accurately reflects the work completed in this Application for Payment. The Contractor also certifies that all payments have been made for work on previous Applications for Payment and also that the Current Payment is Due.

(Authorizing Signature)

dwb, inc.

dwb, inc.

Date: APR 30, 2020

State Authorized: Nebraska

County of: Madison

Subscribed and sworn to before

me this 30th day of April, 2020

Notary Public: *Garrett Temme*

My Commission expires: 3-10-2024



ARCHITECT'S CERTIFICATION:

The Architect's signature here certifies that, based on their own observations, the Contract Documents and the information contained herein, this document accurately reflects the work completed in this Application for Payment. The Architect also certifies the Contractor is entitled to the amount certified for payment.

AMOUNT CERTIFIED:

\$116,071.15

Michael D. Fahler

(Architect's Signature)

Date:

5/6/2020

APPLICATION FOR PAYMENT - CONTINUATION SHEET

CAP703

From:
 dwb, inc.
 PO Box 626
 Madison, NE 68748

To:
 Madison Public Schools
 PO Box 450
 Madison, NE 68748

Project:
 MHS GYM & LOCKER RM
 Madison High Gym & Lockers Addition
 Madison, NE

A Item No	B Description of Work	C Contract Value	D Work Completed		E This Period	F Materials Presently Stored (Not In D or E)	G Total Completed and Stored To Date (D+E+F)	H Balance To Finish (C - G)	I Retainage (If Variable Rate)
			From Previous Application (D + E)	% (G / C)					
1	General	489,556.00	343,783.00	24,294.00	0.00	0.00	368,077.00	121,479.00	18,403.85
2	Guard Rail, Striping, Signs	9,250.00	0.00	0.00	0.00	0.00	0.00	9,250.00	0.00
3	Drain Tile	5,980.00	5,456.00	0.00	524.00	0.00	5,980.00	0.00	299.00
4	Termite Treatment	2,618.00	2,618.00	0.00	0.00	0.00	2,618.00	0.00	130.90
5	Dumpster, Fencing, Erosion Con	6,800.00	6,800.00	0.00	0.00	0.00	6,800.00	0.00	340.00
6	Grading	30,000.00	30,000.00	0.00	0.00	0.00	30,000.00	0.00	1,500.00
7	Landscape	7,200.00	0.00	0.00	0.00	0.00	0.00	7,200.00	0.00
8	Fill & Backfill	6,000.00	6,000.00	0.00	0.00	0.00	6,000.00	0.00	300.00
9	Footings & Cast in place walls	168,000.00	168,000.00	0.00	0.00	0.00	168,000.00	0.00	8,400.00
10	Steel Reinforcement	20,148.00	20,148.00	0.00	0.00	0.00	20,148.00	0.00	1,007.40
11	Concrete Floors, Steps, Stoops	43,470.00	43,470.00	0.00	0.00	0.00	43,470.00	0.00	2,173.50
12	Precast Panels	395,000.00	395,000.00	0.00	0.00	0.00	395,000.00	0.00	19,750.00
13	Precast & Steel Erection	197,300.00	175,400.00	0.00	0.00	0.00	175,400.00	21,900.00	8,770.00
14	Masonry	211,500.00	181,000.00	0.00	0.00	0.00	181,000.00	30,500.00	9,050.00
15	Structural Steel	174,500.00	136,988.75	0.00	4,600.00	0.00	141,588.75	32,911.25	7,079.44
16	Rough Framing Carpentry	19,604.00	19,604.00	0.00	0.00	0.00	19,604.00	0.00	980.20
17	Finish Carpentry	3,646.00	2,446.00	1,200.00	0.00	0.00	3,646.00	0.00	182.30
18	Fluid Applied Waterproofing	6,988.00	6,481.00	0.00	0.00	0.00	6,481.00	507.00	324.05
19	Foam Fill Insulation	3,000.00	3,000.00	0.00	0.00	0.00	3,000.00	0.00	150.00
20	Foam Board Insulation	780.00	780.00	0.00	0.00	0.00	780.00	0.00	39.00
21	Air Barriers & Flashings	21,893.00	21,893.00	0.00	0.00	0.00	21,893.00	0.00	1,094.65
22	M Roof, Siding, Soffits, flash	328,700.00	218,188.01	8,629.74	0.00	0.00	226,817.75	101,882.25	11,340.89
23	Sealants	4,500.00	3,500.00	0.00	0.00	0.00	3,500.00	1,000.00	175.00
24	HM Doors & Frames	42,703.00	1,500.00	1,000.00	0.00	0.00	35,888.00	6,815.00	1,794.40
25	Hatch Doors	1,400.00	1,400.00	0.00	0.00	0.00	1,400.00	0.00	70.00
		2,200,536.00	1,793,455.76	35,123.74	38,512.00	1,867,091.50	85	333,444.50	93,354.58

APPLICATION FOR PAYMENT - CONTINUATION SHEET

From: dwb, inc.
PO Box 626
Madison, NE 68748

To: Madison Public Schools
PO Box 450
Madison, NE 68748

Project:

MHS GYM & LOCKER RM
Madison High Gym & Lockers Addition
Madison, NE

Application No: 15
Application Date: 4/30/2020
Period To: 4/30/2020
Contract Date: 12/18/2018
Architects Project#:

A Item No	B Description of Work	C Contract Value	D Work Completed		E This Period	F Materials Presently Stored (Not In D or E)	G Total Completed and Stored To Date (D+E+F)	% (G/C)	H Balance To Finish (C-G)	I Retainage (If Variable Rate)
			From Previous Application (D+E)							
26	Overhead Doors	3,551.00	0.00	0.00	0.00	710.00	710.00	20	2,841.00	35.50
27	Alum Doors, Frames, Windows	57,064.00	11,860.00	0.00	0.00	0.00	11,860.00	21	45,204.00	593.00
28	Metal Framing & Drywall	23,940.00	23,695.00	0.00	0.00	0.00	23,695.00	99	245.00	1,184.75
29	Ceramic Tile	21,637.00	3,702.87	14,334.04	0.00	0.00	18,036.91	83	3,600.09	901.84
30	Acoustical Ceiling	7,399.00	0.00	6,590.00	0.00	0.00	6,590.00	89	809.00	329.50
31	Painting	23,923.00	6,645.00	10,000.00	0.00	0.00	16,645.00	70	7,278.00	832.25
32	Resin Floors	22,400.00	0.00	0.00	0.00	0.00	0.00	0	22,400.00	0.00
33	Wood Gym Floor	126,900.00	6,345.00	0.00	0.00	56,394.00	62,739.00	49	64,161.00	3,136.95
34	RR Stalls & Accessories	21,079.00	6,846.00	0.00	0.00	0.00	6,846.00	32	14,233.00	342.30
35	Lockers	18,500.00	0.00	0.00	0.00	15,200.00	15,200.00	82	3,300.00	760.00
36	Gym Equipment	36,122.00	0.00	0.00	0.00	0.00	0.00	0	36,122.00	0.00
37	Laminate Casework	24,760.00	0.00	22,181.00	0.00	0.00	22,181.00	90	2,579.00	1,109.05
38	Telescopic Bleachers	90,675.00	0.00	0.00	0.00	0.00	0.00	0	90,675.00	0.00
39	Elevator	71,166.00	24,558.00	834.00	0.00	0.00	25,392.00	36	45,774.00	1,269.60
40	Fire Sprinklers	22,791.00	21,661.40	0.00	0.00	0.00	21,661.40	95	1,129.60	1,083.07
41	HVAC	195,285.00	72,286.00	122,999.00	0.00	0.00	195,285.00	100	0.00	9,764.25
42	Plumbing	195,285.00	93,150.00	59,275.00	0.00	0.00	152,425.00	78	42,860.00	7,621.25
43	Site Utilities	234,000.00	99,696.00	20,000.00	0.00	0.00	119,696.00	51	114,304.00	5,984.80
44	Electrical	195,178.00	137,389.00	45,776.00	0.00	0.00	183,165.00	94	12,013.00	9,158.25
45	C.O. #1 Unsuit Soils	10,556.30	10,556.30	0.00	0.00	0.00	10,556.30	100	0.00	527.82
46	C.O. #2	5,249.10	5,249.10	0.00	0.00	0.00	5,249.10	100	0.00	262.46
47	C.O. #3	5,716.18	3,826.00	1,414.00	0.00	0.00	5,240.00	92	476.18	262.00
48	C.O. #4	13,971.60	8,218.00	0.00	0.00	0.00	8,218.00	59	5,753.60	410.90
49	C.O. #5	10,786.60	0.00	3,580.00	0.00	0.00	3,580.00	33	7,206.60	179.00
50	C.O. #6	13,531.40	0.00	2,577.00	0.00	0.00	2,577.00	19	10,954.40	128.85
		3,652,002.18	2,329,139.43	344,683.78		110,816.00	2,784,639.21	76	867,362.97	139,231.97

APPLICATION FOR PAYMENT

CAP702
Page: 1 of 3

To:
Madison Public Schools
PO Box 450
Madison, NE 68748

PROJECT:
MHS MEZZ-COMMONS-RR
Mezzanine, Commons, Concession, RR
Madison, NE

Application No.: Application Date: Period To: Contract Date:
15 APR 30, 2020 APR 30, 2020 DEC 18, 2018

Project Nos:

Distribution List:
 Owner
 Architect
 Contractor
 Construction Mgr
 Field
 Other

From Contractor:
dwb, inc.
PO Box 626
Madison, NE 68748

VIA ARCHITECT:
Fakler Architects
1001 N 6th St
Beatrice, NE 68310

CONTRACT FOR:

Contractor's Application for Payment

Application is made for payment as shown below, with attached Continuation Sheet.

- 1. Original Contract Amount: \$ 1,678,133.00
- 2. Net of Change Orders: \$ 57,114.74
- 3. Net Amount of Contract: \$ 1,735,247.74
- 4. Total Completed & Stored to Date: \$ 1,499,200.63

5. Retainage Summary:

- a. 5.00 % of Completed Work \$ 67,000.46
- b. 5.00 % of Stored Material \$ 7,959.60
- Total Retainage: \$ 74,960.06
- 6. Total Completed Less Retainage: \$ 1,424,240.57
- 7. Less Previous Applications: \$ 1,279,114.45

8. Current Payment Due, This Application: \$ 145,126.12

9. Contract Balance (Including Retainage): \$ 311,007.17

CHANGE ORDER Activity	Additions	Subtractions
Total previously approved:	57,114.74	0.00
Total approved this Month:	0.00	0.00
Sub Totals:	57,114.74	0.00
NET of Change Orders:	57,114.74	

CONTRACTOR'S CERTIFICATION:

The Contractor's signature here certifies that, to the best of their knowledge, this document accurately reflects the work completed in this Application for Payment. The Contractor also certifies that all payments have been made for work on previous Applications for Payment and also that the Current Payment is Due.

(Authorizing Signature) Don Finck
dwb, inc.

Date: APR 30, 2020
State Authorized: Nebraska
County of: Madison

Subscribed and sworn to before me this 30th day of April, 2020
Notary Public: Garrett Temmie
My Commission expires: 3-10-2024



ARCHITECT'S CERTIFICATION:

The Architect's signature here certifies that, based on their own observations, the Contract Documents and the information contained herein, this document accurately reflects the work completed in this Application for Payment. The Architect also certifies the Contractor is entitled to the amount certified for payment.

AMOUNT CERTIFIED: \$145,126.12 Date: 5/6/2020
Michael D. Fabler
(Architect's Signature)

APPLICATION FOR PAYMENT - CONTINUATION SHEET

<p>From: dwb, inc. PO Box 626 Madison, NE 68748</p>	<p>To: Madison Public Schools PO Box 450 Madison, NE 68748</p>
<p>Project: MHS MEZZ-COMMONS-RR Mezzanine, Commons, Concession, RR Madison, NE</p>	
<p>Application No: 15 Application Date: 4/30/2020 Period To: 4/30/2020 Contract Date: 12/18/2018 Architects Project#:</p>	

A Item No	B Description of Work	C Contract Value		D Work Completed		E This Period	F Materials Presently Stored (Not In D or E)	G Total Completed and Stored To Date (D+E+F)	% (G/C)	H Balance To Finish (C-G)	I Retainage (If Variable Rate)
		From Previous Application (D+E)	Work Completed This Period	From Previous Application (D+E)	Work Completed This Period						
1	General	111,412.00	87,729.00	5,917.00	0.00	93,646.00	84	17,766.00	4,682.30		
2	Demolition	6,685.00	6,685.00	0.00	0.00	6,685.00	100	0.00	334.25		
3	Grading	49,600.00	49,600.00	0.00	0.00	49,600.00	100	0.00	2,480.00		
4	Termite Treatment	929.00	929.00	0.00	0.00	929.00	100	0.00	46.45		
5	Fill & Backfill	6,000.00	6,000.00	0.00	0.00	6,000.00	100	0.00	300.00		
6	Helical Piles	113,000.00	113,000.00	0.00	0.00	113,000.00	100	0.00	5,650.00		
7	Footings, Cast in place walls	139,000.00	139,000.00	0.00	0.00	139,000.00	100	0.00	6,950.00		
8	Steel Reinforcement	28,614.00	25,948.00	2,666.00	0.00	28,614.00	100	0.00	1,430.70		
9	Concrete: Floors, Steps, Stoop	33,646.00	33,646.00	0.00	0.00	33,646.00	100	0.00	1,682.30		
10	Steel Erection	40,000.00	37,875.00	0.00	0.00	37,875.00	95	2,125.00	1,893.75		
11	Masonry	78,500.00	10,000.00	30,000.00	0.00	40,000.00	51	38,500.00	2,000.00		
12	Structural Steel	133,200.00	125,824.00	2,620.00	0.00	128,444.00	96	4,756.00	6,422.20		
13	Rough Framing Carpentry	15,164.00	15,164.00	0.00	0.00	15,164.00	100	0.00	758.20		
14	Finish Carpentry	2,480.00	2,480.00	0.00	0.00	2,480.00	100	0.00	124.00		
15	Foam Fill Insulation	1,730.00	1,730.00	0.00	0.00	1,730.00	100	0.00	86.50		
16	Foam Board Insulation	380.00	380.00	0.00	0.00	380.00	100	0.00	19.00		
17	Rolled Air Barriers	8,557.00	8,557.00	0.00	0.00	8,557.00	100	0.00	427.85		
18	Fluid Air Barrier & Flashings	3,475.00	2,713.00	0.00	0.00	2,713.00	78	762.00	135.65		
19	Metal Roof, Siding, Soffit, Fl	182,666.00	80,719.47	75,429.02	0.00	156,148.49	85	26,517.51	7,807.43		
20	Existing Roof Tie In	5,000.00	5,000.00	0.00	0.00	5,000.00	100	0.00	250.00		
21	Sealants	900.00	900.00	0.00	0.00	900.00	100	0.00	45.00		
22	HM Doors & Frames	23,088.00	1,500.00	0.00	0.00	14,387.00	62	8,701.00	719.35		
23	Coiling Doors	6,901.00	0.00	0.00	0.00	0.00	0	6,901.00	0.00		
24	Aluminum Doors, Frames, Window	100,131.00	17,791.00	44,941.34	0.00	62,732.34	63	37,398.66	3,136.62		
25	Metal Framing & Drywall	71,880.00	71,860.00	0.00	0.00	71,860.00	100	20.00	3,593.00		
		1,162,938.00	845,030.47	161,573.36	12,887.00	1,019,490.83	88	143,447.17	50,974.55		

APPLICATION FOR PAYMENT - CONTINUATION SHEET

<p>From: dwb, inc. PO Box 626 Madison, NE 68748</p>	<p>To: Madison Public Schools PO Box 450 Madison, NE 68748</p>
<p>Project: MHS MEZZ-COMMONS-RR Mezzanine, Commons, Concession, RR Madison, NE</p>	
<p>Application No: 15 Application Date: 4/30/2020 Period To: 4/30/2020 Contract Date: 12/18/2018 Architects Project#:</p>	

A Item No	B Description of Work	C Contract Value		D Work Completed		E This Period	F Materials Presently Stored (Not In D or E)	G Total Completed and Stored To Date (D+E+F)	H Balance To Finish (C - G)	I Retainage (if Variable Rate)
		From Previous Application (D + E)	From This Period	From Previous Application (D + E)	This Period					
26	Ceramic Tile	41,715.00	0.00	8,978.00	0.00	0.00	2,232.00	11,210.00	30,505.00	560.50
27	Acoustical Ceiling	2,632.00	0.00	0.00	0.00	0.00	0.00	0.00	2,632.00	0.00
28	Painting	16,772.00	0.00	14,489.00	0.00	0.00	0.00	14,489.00	2,283.00	724.45
29	Resin Floors	6,930.00	0.00	0.00	0.00	0.00	0.00	0.00	6,930.00	0.00
30	RR Stalls & Accessories	20,257.00	0.00	274.00	0.00	0.00	0.00	274.00	19,983.00	13.70
31	Laminate Casework	9,241.00	0.00	0.00	0.00	6,000.00	0.00	6,000.00	3,241.00	300.00
32	Fire Sprinklers	16,106.00	0.00	9,395.40	0.00	0.00	5,950.00	15,345.40	760.60	767.28
33	Plumbing	151,038.00	0.00	110,615.00	0.00	0.00	40,423.00	151,038.00	0.00	7,551.90
34	HVAC	151,039.00	0.00	62,768.00	2,182.00	0.00	75,629.00	140,579.00	10,460.00	7,028.95
36	Electrical	99,465.00	0.00	64,284.00	10,102.00	0.00	22,071.00	96,457.00	3,008.00	4,822.85
37	C.O. #1	13,000.10	0.00	12,768.00	0.00	0.00	0.00	12,768.00	232.10	638.40
38	C.O. #2	2,877.80	0.00	2,877.00	0.00	0.00	0.00	2,877.00	0.80	143.85
39	C.O. #3	10,111.84	0.00	9,351.40	720.00	0.00	0.00	10,071.40	40.44	503.58
40	C.O. #4	3,485.20	0.00	0.00	429.00	0.00	0.00	429.00	3,056.20	21.45
41	C.O. #5	14,040.70	0.00	1,620.00	9,193.00	0.00	0.00	10,813.00	3,227.70	540.65
42	C.O. #6	13,599.10	0.00	0.00	7,359.00	0.00	0.00	7,359.00	6,240.10	367.95
		1,735,247.74	197,558.36	1,142,450.27	197,558.36	159,192.00	1,499,200.63	236,047.11	74,960.06	

2017 Freightliner – Thomas C2

53 Passenger Capacity

Engine: Cummins ISB 6.7 Liter – 220 HP/600 Torque

Transmission: Allison 2500 – 5 Speed Automatic

Brakes: Hydraulic

Mileage: 28,433 as of 01/09/2020

ADDITIONAL SPECIFICATIONS:

126,000 BTU Air Conditioning (Front and Rear bulkheads – in wall)

100 Gallon Fuel Tank (mounted between frame rails)

270 Amp Alternator

Triple (3) Batteries

750 Watt Block Heater

11R22.5 Tires w/ Mud & Snow Tread on Rear

Cruise Control

Tilt Steering Wheel

LED Lights

39" School Bus Seats

Tinted Windows

Heated/Remote Control Review Mirrors

LED Stop Arm Lights

AM/FM Radio w/ PA

Strobe Light

Back Up Alarm

Dual (2) 84,000 BTU Rear Heater

Tinted Windows

Roof Painted White

Remaining Factory Engine & Transmission Warranty until 2021

PRICE.....\$66,750.00

2018 Freightliner – Thomas C2

53 Passenger Capacity

Engine: Cummins ISB 6.7 Liter – 220 HP/600 Torque

Transmission: Allison 2500 – 5 Speed Automatic

Brakes: Hydraulic

Mileage: 15,370 as of 01/09/2020

ADDITIONAL SPECIFICATIONS:

100 Gallon Fuel Tank (mounted between frame rails)

240 Amp Alternator

Triple (3) Batteries

750 Watt Block Heater

11R22.5 Tires w/ Mud & Snow Tread on Rear

Cruise Control

Tilt Steering Wheel

LED Lights

39" School Bus Seats

Tinted Windows

Heated/Remote Control Review Mirrors

LED Stop Arm Lights

AM/FM Radio w/ PA

Strobe Light

Back Up Alarm

Dual (2) 84,000 BTU Rear Heater

Tinted Windows

Roof Painted White

Remaining Factory Engine & Transmission Warranty until 2022

PRICE.....\$66,250.00





Madison High School Phase IV

700 Kent St.
Madison, NE 68748

Architect: Name: Fakler Architects LLC Address: 1001 N. 6th St. Beatrice, NE 68310 Direct: (402) 228-3020	General Contractor: Name: DWB Inc. Address: 110 W. 2nd St. Madison, NE 68748 Direct: Doug Wagner (402) 228-3020 dougwag@yahoo.com	HH/AL Job Superintendent: Name: Bob Dudzik E-Mail: bdudzik@h2igroup.com Direct: (612) 669-6119	HH/AL PM: Name: Shawn Sundine E-Mail: ssundine@h2igroup.com Direct: (319) 242-7606	HH/AL Engineer: Name: Lindsey B. Hage E-Mail: lhage@h2igroup.com Direct: (612) 465-7177	HH/AL Sales Rep: Name: Mike Larson E-Mail: mlarson@h2igroup.com Direct: (402) 510-5193
--	---	--	--	---	--

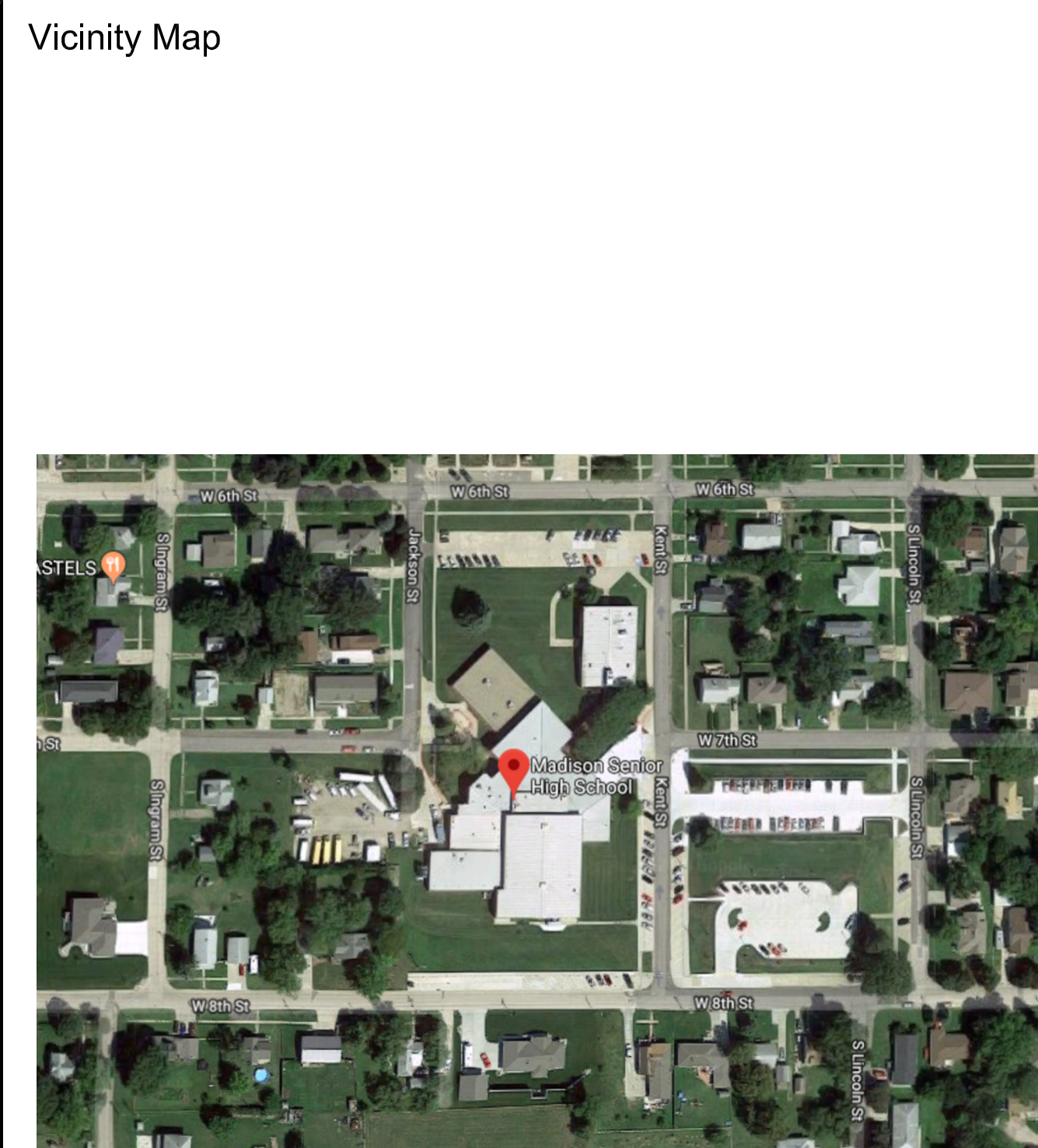

General Notes:

Working Conditions
 The building is enclosed and weather tight. All wet and trowel trades work is completed. Permanent heat, light, and ventilating equipment is installed and operating, maintaining a temperature range of 55 to 78 degrees Fahrenheit, and a relative humidity range of 35-50%.

Concrete Tolerance
 The concrete slab shall be troweled smooth and level to a tolerance of +/- 1/8" in a 10' radius. H2I Group will mark with paint any areas requiring remedial repair, circling the area where the work is to be completed and how much; fill + 1/4" (up), or grind - 3/8" (down). In situations where the concrete slab is found unacceptable, it is the general contractor's responsibility to correct such unsatisfactory work by machine grinding and/or filling. The general contractor shall assume the full responsibility for proper and permanent bonding of leveling or fillers.

Concrete Dryness
 The curing of any concrete slab depends upon the type of construction, grade location of the building, local water table, climatic condition at time placement, environmental conditions after placement, and moisture barrier design and placement.

Effective October 1, 2011, the Maple Flooring Manufacturers Association will recognize relative humidity (RH) testing for reading concrete moisture levels within a slab prior to flooring installation. MFMA recommends that the relative humidity level for a concrete slab for a non-glue down maple floor system is 85% or lower, and for glue down systems the relative humidity is 75% or lower.

H2I Group will visit and test once the slab is, at a minimum, 60 days cured. We will report our findings in writing to the general contractor.
 NOTE: The RH testing measures the inside moisture of the concrete not the emissions. *It has been taking many slabs an average of 120 days to pass the RH test, causing major scheduling delays.*

Site Conditions
 The room is clear of all materials, all overhead work including mechanical, lighting, backstops, and scoreboards are installed and working. The concrete floor is broom cleaned, and free from all debris. H2I Group is not responsible for any damages caused by other sub-contractors.

1. Floor direction to be selected and hoops shall be installed prior to flooring installation.
2. H2I Group is not responsible for final cleaning.
3. All colors may vary. Reference color chart for exact color.
4. Exterior thresholds, furnished by others and installed by others.
5. Lighting, electrical, sewer and their cover plates, furnished by others and installed by others.
6. Disposing of hazardous waste, by others.

Project specific Notes:

1. Concrete corrections by others.
2. Floor sleeves, furnished by Others and installed by Others.
3. Cover plates, furnished by Others and installed by Others.
4. Joint sealant, by Others.
5. Wall base furnished by H2I Group and installed by H2I Group.
6. Wood Floors: (2) Coats of oil based sealer, and (2) coats of oil based finish.
7. Basketball court lines are dimensioned to inside of game line striping, all other courts are dimensioned to the outside of game line striping.
8. Exact location of basketball courts will be determined by location of basketball backstops. All other game markings are dimensioned from basketball courts or directly from the walls.

Approval Stamps / Notes:



H2I Group, Inc. Headquarters
 430 Industrial Boulevard
 Minneapolis, Minnesota 55413

100% Employee Owned and Driven

An employee owned company engaged in the distribution of educational, industrial and institutional equipment.

www.h2igroup.com
 Call us Toll Free: 1-888-239-8747
 info@h2igroup.com

These drawings remain the property of H2I Group. They are a loaned subject to be returned upon demand, and upon the express condition that it will not be used directly or indirectly in any way detrimental to H2I Group. They are furnished for the sole intent of approval and installation for products supplied by H2I Group. H2I Group does not guarantee their accuracy to, nor warrant their fitness for use by others.

Professionals that create Solutions

Authorized **Robbins** Dealer

Project status	R 2
Date	May 04, 2020
Project No.	57775

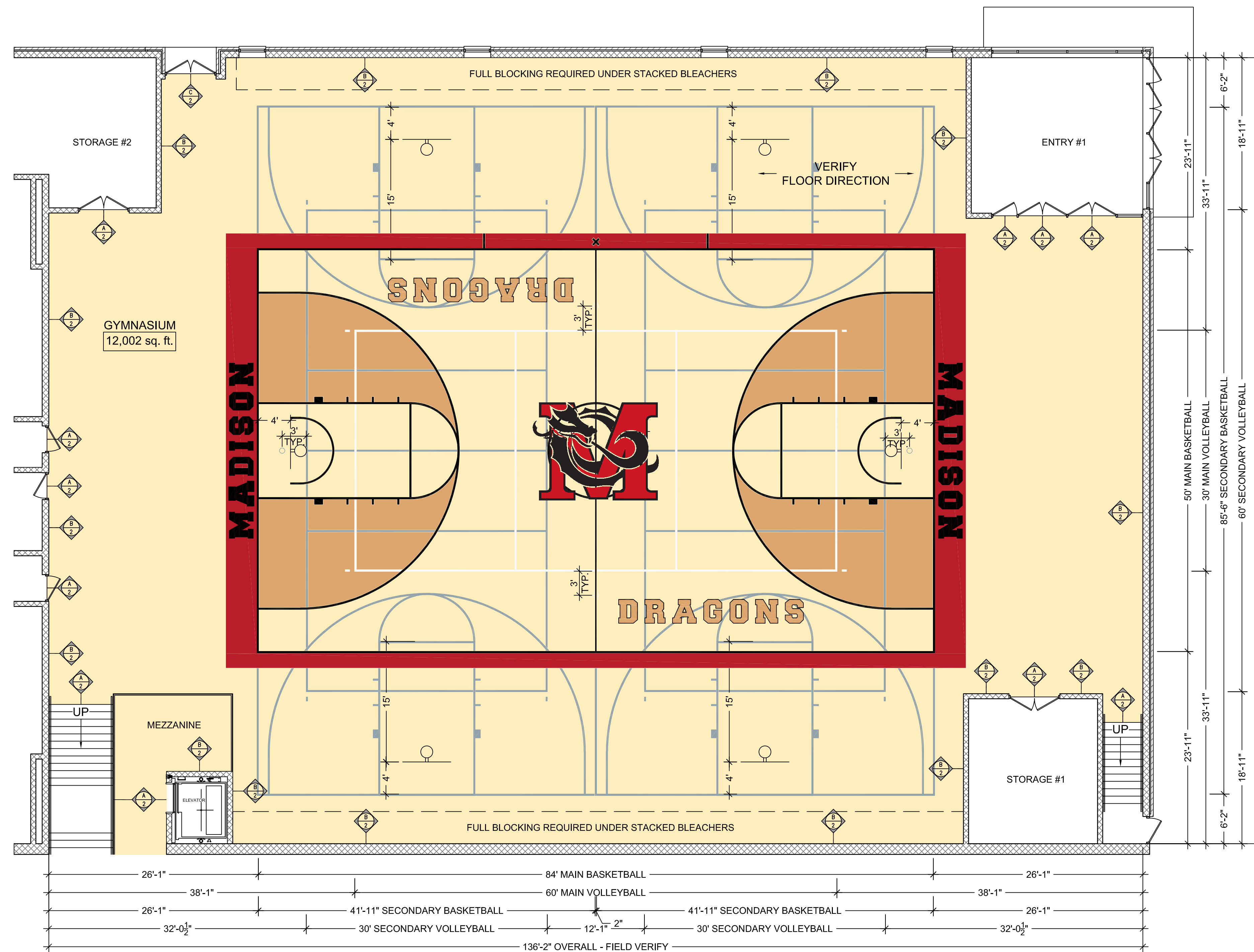

Room Schedules				
Room #	Finish	Coats of sealer	Coats of finish	Base
Gymnasium	Bona	2	2	Oil

Gameline Markings Schedule					
Court Description	Qty	Priority	Color	Court Dim's	Line Width
Main Basketball	1	01	Black	84'x50'	0'-2"
Main Basketball Border	1	01	Red	84'x50'	1'-9" Sides 3'-9" Ends
Main BB 3pt Arc	2	01	Jacobean	--	--
Main Volleyball	1	02	White	60'x30'	0'-2"
Secondary Basketball	2	03	Gray	85'-6"x41'-11"	0'-2"
Secondary Volleyball	2	04	Gray	60'x30'	0'-2"

Logo & Court Text Schedule				
Description	Qty	Color	Size	Font/Notes
Center Logo	1	Black, Red	12'x16'	
Border Text (Madison)	2	Black	3'x22'	Freshman Font
Floor Text (Dragons)	2	Jacobean, Black	3'x23'	Freshman Font

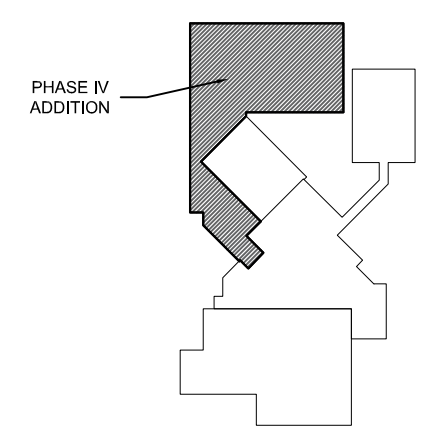

KEY PLAN

PARTIAL FLOOR PLAN
Scale: 1/8" = 1'-0"

Project Timeline		
Date	Project status	By
2/5/2019	Submittal	LBH
10/1/2019	R 1	LBH
5/4/2020	R 2	LBH



Project Name		
Project Info.		
Maddison High School Phase IV		
Project No.	Engineer	Sheet
57775	LBH	01 of 02

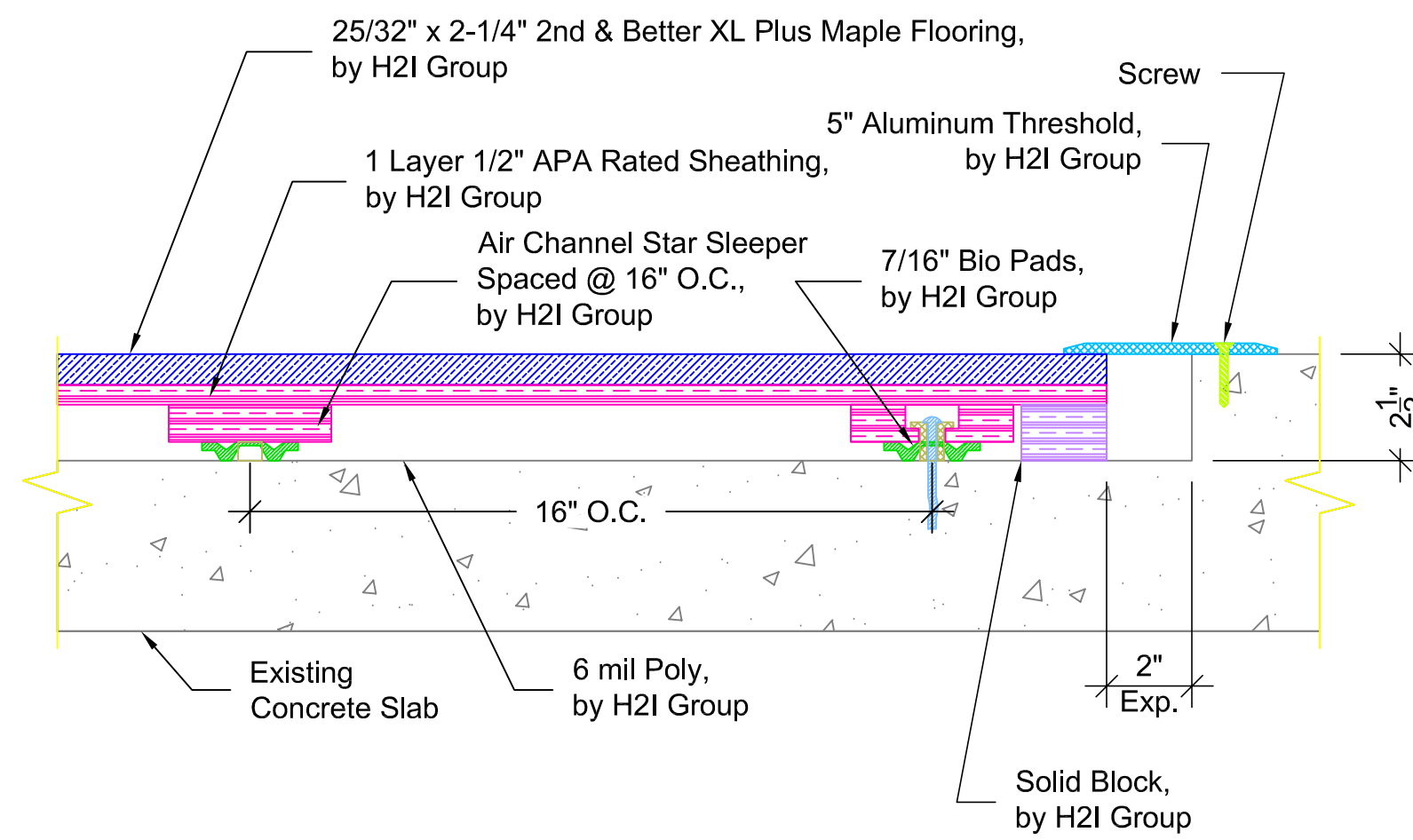

A Interior threshold detail
SCALE: 3"=1'

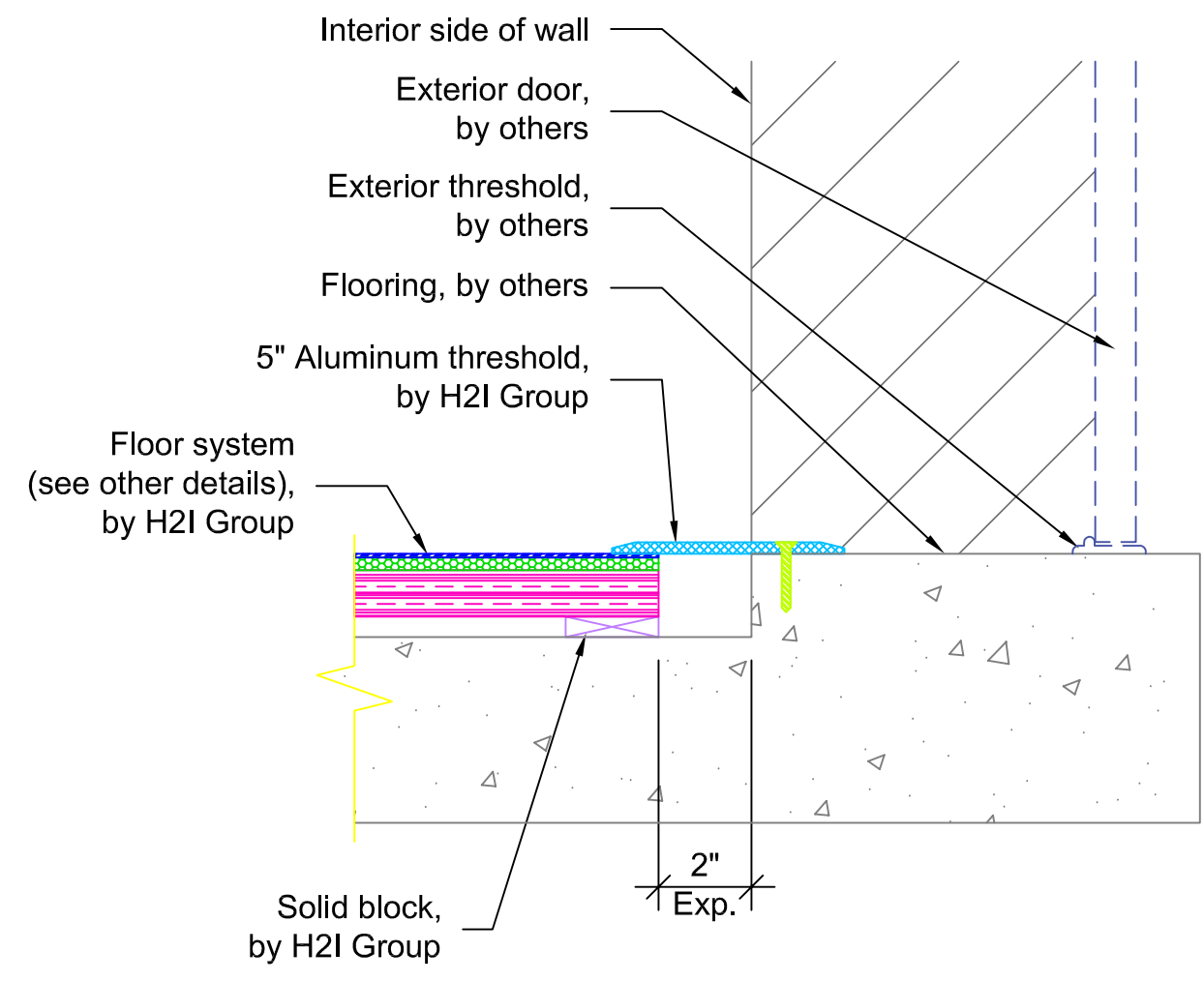

C Exterior threshold detail
SCALE: 3"=1'

SECONDARY TAPE BREAK DETAIL OPTION - TBD

○ Secondary tape break detail
SCALE: 3"=1'

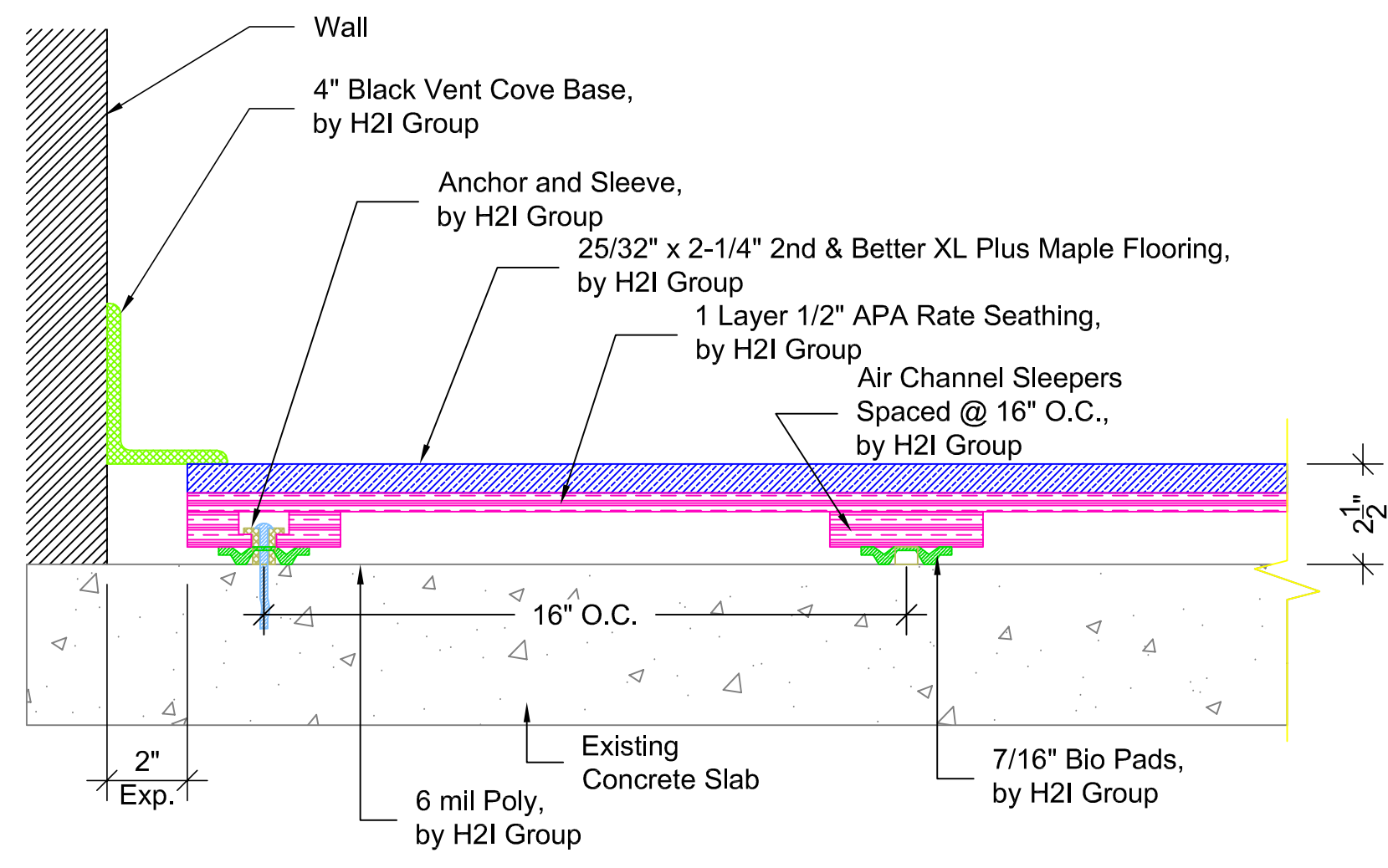

B Interior base detail
SCALE: 3"=1'

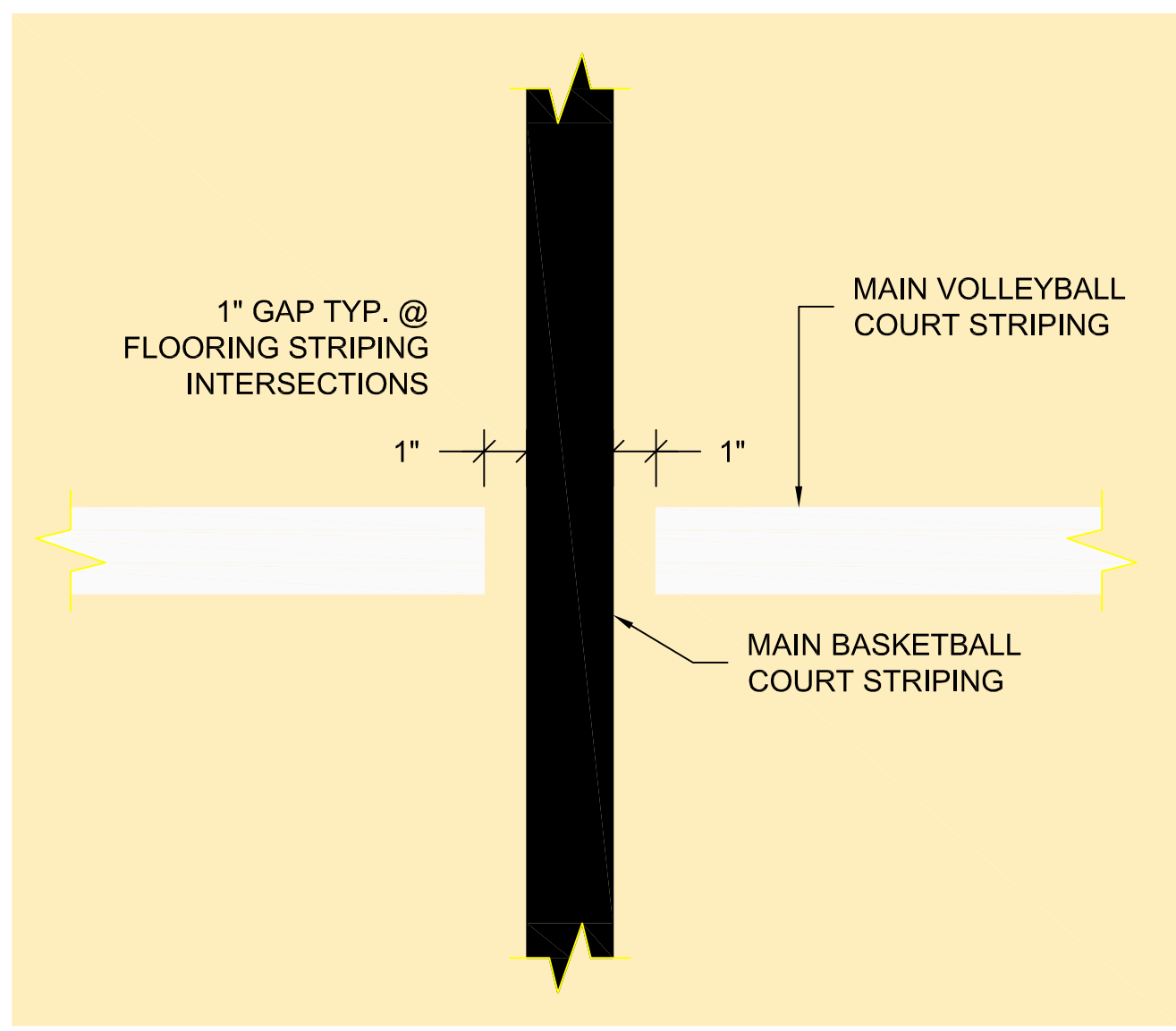

○ 1" tape break detail - TYP.
SCALE: 3"=1'

Project Timeline		
Date	Project status	By
2/5/2019	Submittal	LBH
10/1/2019	R 1	LBH
5/4/2020	R 2	LBH
		
Project Name		
Maddison High School Phase IV		
Project Info.		
Project No.	Engineer	Sheet
57775	LBH	02 of 02

Madison Public Schools

Alan Ehlers
Superintendent

Jim Crilly
HS Principal
Reid Ehrisman
MS Principal/EL

Karla Kush
Elementary Principal

700 So Kent St.
P.O. Box 450
Madison, NE 68748
District Phone (402) 454-3336 Fax (402) 454-2238
Elementary Phone (402) 454-2656 Fax (402) 454-3978

Travis Jordan
Director of CAI
Crystal Ernst
Instructional Coach
Landonn Mackey
Athletic Director
Celine Filsinger
Office Manager

The mission of Madison Public Schools is to prepare students to be competent, confident, productive, and responsible citizens.

Mr. Jordan's April Report

Curriculum, Assessment, and Instruction

Curriculum:

- We have selected Into Literature from Houghton Mifflin Harcourt for the Middle School ELA Program. <https://vimeo.com/329411635>
 - Quote for a 3-year License is attached
 - The maximum amount of professional development is included.
 - All materials to install the program immediately are included.
 - Includes online access as well as paper material.

Assessment:

- Looking at our MAP data from this year, my big takeaway is the increase in time spent and decrease in "Rapid-Guess" from Fall to Winter.
(Avg. Guess is # of students with any "Rapid Guesses" – Average guesses for those students)

	Fall	Fall	Winter	Winter
ELA	<u>Avg. Time</u>	<u>Avg. Guesses</u>	<u>Avg. Time</u>	<u>Avg. Guesses</u>
6th	56 min	11 - 7	61 min	8 - 4
7th	59 min	13 - 8.6	75 min	6 - 7.3
8th	52 min	18 - 7.6	52 min	16 - 6

	Fall	Fall	Winter	Winter
Math	<u>Avg. Time</u>	<u>Avg. Guesses</u>	<u>Avg. Time</u>	<u>Avg. Guesses</u>
6th	63 min	5 - 6	62 min	4 - 2.5
7th	57 min	7 - 3.2	65 min	6 - 2.5
8th	57 min	17 - 5.2	61 min	9 - 3.3

Instruction:

- Teachers have really gotten more comfortable with the "Distance Learning" and many have been thinking of ways to use what they have learned in the future too.
 - Make Instruction easier for Substitutes
 - New ways of turning in work without using paper
 - Providing instruction for kids missing school
 - Fun ways to present lessons in class

Madison Public Schools

Alan Ehlers
Superintendent
Jim Crilly
HS Principal/AD
Reid Ehrisman
MS Principal/IPM/EL

700 So Kent St.
P.O. Box 450
Madison, NE 68748
District Phone (402) 454-3336 Fax (402) 454-2238
Elementary Phone (402) 454-2656 Fax (402) 454-3978

Karla Kush
Elementary Principal
Travis Jordan
Director of CAI
Christine Knapp
Office Manager

The mission of Madison Public Schools is to prepare students to be competent, confident, productive, and responsible citizens.

Mrs. Kush – May 5, 2020
Elementary Principal

Number of Students in Elementary School

Grade Level	Current as of 5/5/20	4/8/20	3/4/20	2/5/19	11/4/19	10/4/19	9/4/19	Start of the Year 8/7/19
PreK-3	26	26	25	25	26	26	26	26
PreK-4	36	36	36	35	36	36	36	33
Kindergarten	43	43	43	44	44	43	43	46
1 st Grade	39	39	37	36	36	35	36	37
2 nd Grade	32	32	32	31	30	27	28	28
3 rd Grade	35	35	34	35	32	33	34	34
4 th Grade	37	37	37	37	36	35	36	39
5 th Grade	39	39	38	38	35	35	37	36
Total	287	287	282	281	275	270	276	279
								Last year ended with 268

Student Report

	Aug-Sept	Sept-Oct	Oct-Nov	Nov-Dec	Dec-Jan	Jan-Feb	Feb-March	March-April	April-May
Attendance	97.08%	95.5%	96.82%	96.43%	94.42%	94.31%	95.39%	NA	NA
Tardy %	6.5%	10%	12%	14%	14.5%	14%	11%	NA	NA
	(all < 5 tardies)	(all < 5 tardies)	(3 > 5 tardies)	(all < 5 tardies)	(3 > 5 tardies)	(all < 5 tardies)	(2 > 5 tardies)		

1. The teachers in grades 2-5 have been using google classroom for online learning. Teachers have been asked to teach in ways they never have. For many it was out of their comfort zones, but they have learned how and I am grateful for their continuous efforts!
2. Along with making learning opportunities available, teachers have been asked to make contact with students, whether by email, calls, or texts, to check-in with them. Our school counselor has also been in contact with students as we are wanting to check on students' social/emotional health during this time with COVID-19.
3. Students have been asked to bring iPads back to the elementary from May 18-May 20. Mrs. Braithwait and I have been working on a plan for a smooth process making physical contact minimal.

4. Kindergarten round-up is cancelled (previously scheduled for April 9th). We are emailing/ mailing out what is needed for physical exams, eye exams, immunizations, and allergy/asthma forms.
5. PreK will be sending out post cards, posting on Facebook, putting notice in the Madison StarMail newspaper, and reaching out to families that we know may be interested in attending Madison Public School's preschool.
6. We have moved many of the rooms at the elementary to allow for the new Little Dragons Child Care! So far, things have been going smoothly.
7. Madison Elementary has been approved to receive \$300 from the Patch Grant for indoor recess equipment!
8. Teacher check-out day is set for May 20 & May 21.
9. I participated in several zoom meetings (ESU, BIST, etc) and am making initial plans on some steps that will need to take place prior to school starting back up. Students, parents, and staff are going to need extra support and strong leadership that focuses a bit more on the sense of community, rules, and intentional relationships.

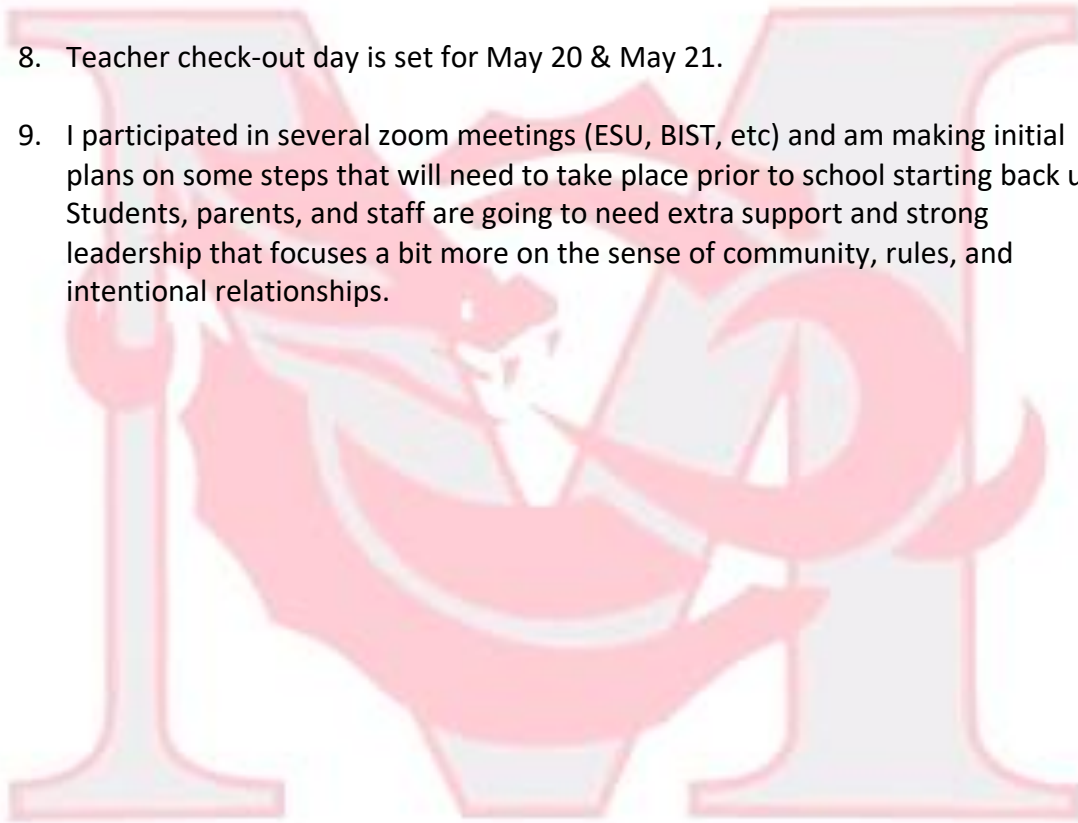

Madison Public Schools Surplus Items

John Deere Mower: 4x4 Mower, brush, cab & blade



John Deere Mower cab:



John Deere Mower deck:



54" John Deere blade



2014 Grasshopper Mower (New in 2014 only 490 hours)



Snapper Push Mower (Does not run)



Snapper Mower: (Does not run)



Old Sprayer:



Industrial Air Compressor:



Miller Matic Welder



Migmaster Welder



Job Smart parts washer:



Older parts washer:



Chain Saw:



Red Score Board/ No controls



Blue Score board:



Red lockers (6 sections)



Grey Lockers



TV & cart:



Laptop carts:



Engine stand:



Bainbridge Bandsaw



Engine Hoist:



Engine stands:



Madison Public Schools

Alan Ehlers
Superintendent
Jim Crilly
HS Principal
Reid Ehrisman
MS Principal/EL
Karla Kush
Elementary Principal

700 So Kent St.
P.O. Box 450
Madison, NE 68748
District Phone (402) 454-3336 Fax (402) 454-2238
Elementary Phone (402) 454-2656 Fax (402) 454-3978

Travis Jordan
Director of CAI
Crystal Ernst
Instructional Coach
Landonn Mackey
Athletic Director
Celine Filsinger
Office Manager

The mission of Madison Public Schools is to prepare students to be competent, confident, productive, and responsible citizens.

May Board Meeting 2020 Report- Jim Crilly HS Principal

Enrollment May 6th

9th- 37 Students
10th- 41 Students
11th- 45 Students
12th-40 Students
Total Enrollment- 163 Students
April Enrollment- 163 students

Senior Class Rank Top Ten

Perez Gomez, Veronica
Navarro, Deicy
Torres, Yesenia
Sjuts, Marie
Jackson, Rachel
Alarcon, Danny

Board Report May 2020



Jim Crilly

Wed 5/6/2020 11:21 AM

To: Alan Ehlers

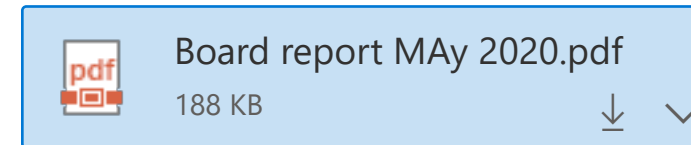

Updated, let me know, thanks

Madison Public Schools

Alan Ehlers
Superintendent
Jim Crilly
HS Principal/AD
Reid Ehrisman
MS Principal/IPM/EL

700 So Kent St.
P.O. Box 450
Madison, NE 68748
District Phone (402) 454-3336 Fax (402) 454-2238
Elementary Phone (402) 454-2656 Fax (402) 454-3978

Karla Kush
Elementary Principal
Travis Jordan
Director of CAI
Christine Knapp
Office Manager

The mission of Madison Public Schools is to prepare students to be competent, confident, productive, and responsible citizens.

Mr. Ehrisman- May 6th, 2020
MS Principal, IPM (Intervention Project Manager), English Learners Director

NUMBER OF STUDENTS IN THE MIDDLE SCHOOL

Grade Level	Current as of 5/6/20	5/7/19
6th Grade	44	26
7th Grade	26	38
8th Grade	41	33
MS Total	111	97

STUDENT ATTENDANCE REPORT

Grade Level	2019-20	2018-19
6th Grade	95.90%	95.01%
7th Grade	95.79%	95.61%
8th Grade	94.88%	96.12%
MS Total	95.50%	95.63%

- The CSI and SIG monthly Zoom meetings were held on April 22nd and May 5th. End of the year presentations were discussed as well as financials moving forward.
- ELPA 21 results were posted on May 1st. The results have started to be reviewed by the EL teachers, Mr. Jordan and myself.
- Preparing the end of the year presentations for the CSI and SIG Grants. The CSI presentation will be on May 28th and the SIG presentation on June 9th.
- Due to the closure of school, BIST support and training has occurred twice via Zoom. Current and future needs of the staff and students were addressed.
- EL teachers, myself and Mr. Jordan have worked on the 2019-20 Annual EL Program Review that needs to be submitted to Mark Brady by the end of May. The district currently has 108 (20% of all students) K-12 EL students.

- We are currently in week five of our six week continuous learning plan. Teachers have really started to grow in their ability to offer instruction online. The majority of them have adapted very well.
- Teacher check-out is scheduled for May 20th and student iPad return is set for May 18-20. We will be returning students personal items that were in lockers at this time as well. All safety measures will be taken in doing this.
- Para staff has done a tremendous job of helping to promote our House System and theme through some painting they have done in the MS.

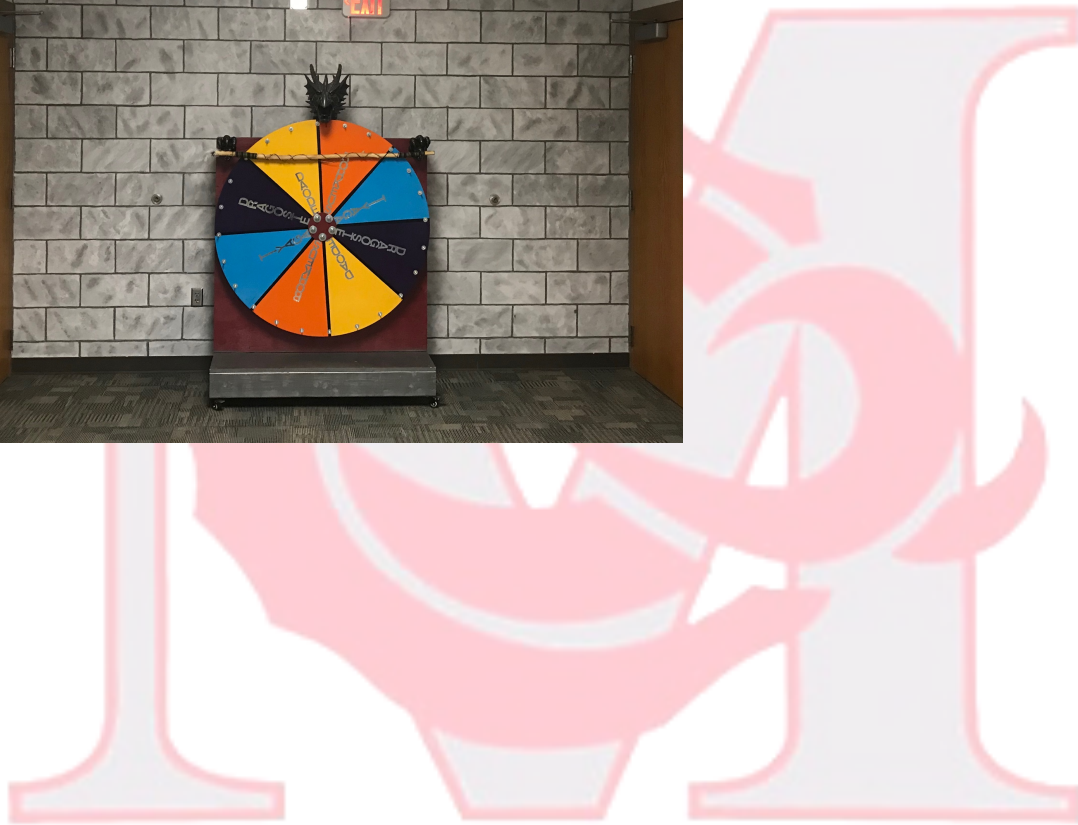

Madison Public Schools

Alan Ehlers
Superintendent
Jim Crilly
HS Principal/AD
Reid Ehrisman
MS Principal/IPM/EL

700 So Kent St.
P.O. Box 450
Madison, NE 68748
District Phone (402) 454-3336 Fax (402) 454-2238
Elementary Phone (402) 454-2656 Fax (402) 454-3978

Karla Kush
Elementary Principal
Travis Jordan
Director of CAI
Christine Knapp
Office Manager

The mission of Madison Public Schools is to prepare students to be competent, confident, productive, and responsible citizens.

Superintendent Report May 2020

○ Phase IV update:

Attached to my report is the field report #13. Exterior brick work is being completed on the north side of the new gym. Cement work for sidewalks and a retaining wall is taking place. Scoreboards and the gym speaker are attached to the wall. Painting is almost complete in the gym. Banners are being moved from one gym to the other.

The majority of the Middle School commons and the Concessions and restroom will be complete before June 1st. Heartland communications has been contacted to come in at any time to start install of the surveillance cameras and to get things wired for wireless access.

Next Steps:

- The company that installs the basketball hoops should arrive on May 11th
- Elevator company to start install around June 1st
- Gym floor install to begin in Early June
- Bleacher install in August.
- Parking lot poured in late July

Everyone still hoping for an August 10st completion of the project. It would be nice to hold our annual kickoff event in August in the new building, but we are going to see what restrictions are placed on that type of event.

Listed below are items I will be looking to purchase to furnish the new area.

- Ice machine
- Upright pop cooler (Will be donated)
- Washer and dryer
- Training table
- Cabinet for tape and medical supplies
- MS commons tables and chairs

○ Staffing update:

- Looking to hire replacements for Pat & Doug as bus drivers and custodians

- With one of the Middle School grants coming to an end and since we have rehired the Middle School teacher, we will plan to reassign one of the Middle School Para's to the Elementary.
 - We will need to also hire one para to help at the Elementary.
-
- At this time, I have confirmed with Lunch Time Solutions that I would like to offer summer feeding starting on July 1st. I have visited with NDE and we are still keeping options open to offer some type of feeding program in June with current staff. My concern is the ability to have staff members who can run the program due to the health concerns going on.
 - Graduation will take place on July 18th at 10:00 am at the football field. If we are able to hold in the gym graduation will take place at 2:00 pm . If the restrictions are not lifted by that time a virtual graduation will take place at 2:00 pm on July 18th. If allowed by the Health Department Mr. Crilly has scheduled prom for August 16th from 6:00-9:00 at the City Auditorium.
 - I would recommend holding off with a Board Work Session at this time.
 - The Little Dragons Child Care is starting to take shape. The Team has submitted an application to be considered for a \$5,000.00 grant. During the May meeting you will have the opportunity to approve the handbook. After that point we will be looking to get the word out to staff about Child Care opportunities.
 - Summer school offerings are still up in the air at this point. We have talked about moving Migrant summer school to the first three weeks in July and may have to offer on-line support to students. The summer watershed programs is also up in the air at this time. The last several years we have offered a Jump Start program at the Elementary but planning for this also plans to be on hold at this time.
 - At this time one idea we are discussing is having the teachers come together for a couple days in early July to plan for the upcoming school year. Current staff was allowed to leave duty free for 4-5 days prior to the district moving to Enrichment learning opportunities. I have had conversations with the MEA representatives who understand the situation.
 - Please review Mr. Crilly's report so you can provide some feedback on the soccer sign project for the 2020-21 school year.
 - I'm just starting the process of getting some information on bus prices as we have spoke about getting one more used bus. The current buses are: 2014, 2013, 2006, 2004.

2017 Freightliner 53 passenger: 28,433 miles with AC for \$66,750

2018 Freightliner 53 passenger: 15,370 miles \$66,250

2016 Blue Bird 53 passenger: 25,000-35,000 miles \$52,750

- A list of School Surplus items is included as a PDF. We are accepting sealed bids until June 5th. At the June 8th Board meeting you will review any bids. Minimum bids have been set and you will have the right to accept or reject any offers. The items will be listed on the schools facebook page and I will place an ad in the Starmail. If we don't sell the mowers we might consider putting on an auction this summer.



6023

Promotion and Retention of Students between Grade Levels

The district is dedicated to the total and continuous development of each pupil enrolled, and students are enrolled at the grade level suited to them academically, socially and emotionally. Students will generally be moved forward from grade to grade in a continuous pattern of achievement and growth that corresponds with his/her own development and the academic standards established for each grade and core subject. The school district follows research-supported guidelines in considering and/or recommending student retention.

When grade retention or acceleration is being considered, the school will refer the student to the PST (Problem Solving Team) process. The PST shall evaluate and recommend a grade placement for the student based on the relevant data. The PST shall consider:

- Mastery of grade level curriculum
- Overall classroom performance and participation
- Performance on standardized test data, as appropriate
- Previous interventions, including retentions
- Age and level of social and emotional maturity
- Regular school attendance
- Expressed preference of parents/guardians

None of the above factors shall be individually determinative. The building principal will make all final decisions about the grade level placement of students.

Retention of students for athletic purposes is prohibited.

Promotion and Retention of Students With Disabilities

For students receiving special education or related services, the Individualized Education Plan Team shall determine grade level placement and promotion. Nothing in this policy shall infringe on any right provided to students with Individualized Education Programs pursuant to the federal Individuals with Disabilities Education Act, Section 504 of the federal Rehabilitation Act of 1972, or the Federal Americans with Disabilities Act.

Adopted on: 7/10/2017

Revised on: _____

Reviewed on: _____

6025

Student Cell Phone and Other Electronic Devices

Students may use cellular phones or other electronic devices while at school, so long as they do so safely, responsibly and respectfully.

By bringing their cell phones and other electronic communication devices to school, students consent to the search of said devices by school staff when the staff determines that such a search is reasonable or necessary.

Students may not have cell phones or electronic devices on while they are in locker rooms or restrooms.

The taking, disseminating, transferring, or sharing of obscene, pornographic, lewd, or otherwise illegal images or photographs, whether by electronic data transfer or otherwise (commonly called texting, sexting, e-mailing, etc.) may constitute a crime under state and/or federal law. Any person engaged in these activities while on school grounds, in a school vehicle or at a school activity will be subject to the disciplinary procedures of the student code of conduct. Any student found to be in possession of obscene, pornographic, lewd, or otherwise illegal images or photographs will be promptly referred to law enforcement and/or other state or federal agencies, which may result in arrest, criminal prosecution and possible inclusion on sex offender registries.

While on school property, as a school activity or in a school vehicle, students may not use their cell phones or electronic devices to bully, harass or intimidate any other person.

Students shall be personally and solely responsible for the security of their electronic devices. The district is not responsible for theft, loss or damage of any electronic device, including or any calls or downloads.

Students who violate this policy will have their cell phones or electronic devices confiscated immediately. The administration will return confiscated devices to the parent or guardian of the offending student, after meeting with the parent or guardian to discuss the rule violation. Students who violate this policy may, at the discretion of the school's administration, be subject to additional discipline, up to and including suspension or expulsion.

Adopted on: 3/14/2016

Revised on: _____

Reviewed on: _____

6026
Emergency Dismissal

The superintendent is responsible for determining when school and/or extracurricular activities should be cancelled or dismissed due to severe weather or other emergency conditions. Coaches and/or sponsors may not conduct practices on days that school is cancelled without first securing the superintendent's specific permission.

Adopted on: 3/14/2016

Revised on: _____

Reviewed on: _____

6027 Field Trips

The board encourages instructional staff to incorporate field trips into the curriculum. These trips should normally be conducted during the school day.

1. General Conditions

All trips must be pre-approved by the teacher's building principal. Out-of-state and overnight trips require pre-approval by the board. The superintendent and principals will develop guidelines for approval of trips and communicate those guidelines to teaching staff.

2. Parental Permission

Each student must submit a signed parental permission slip prior to being allowed to attend a field trip. A new permission slip must be submitted for each trip. Caregivers, as that term is defined in the Nebraska Strengthening Families Act, shall be permitted to sign parental permission slips.

3. Supervision

Sponsoring teachers must ensure that students are adequately supervised and chaperoned by a responsible adult at all times during field trips. Whether paid staff or volunteers, chaperones are prohibited from drinking alcoholic beverages of any kind at any time during any field trip. All chaperones must be at least 21 years of age. Any chaperone who drives students must possess a valid driver's license. Chaperones who drive students in private vehicles must possess adequate insurance coverage. Chaperones do not have any property right in or to a chaperone assignment. The school district may deny or terminate a chaperone assignment for any reason that is not unconstitutional or unlawful. The superintendent's decision shall be final.

4. Student Conduct

Students must comply with the student code of conduct, any applicable extracurricular conduct codes, and all directives by trip chaperones.

Adopted on: 6/11/2018

Revised on: _____

Reviewed on: _____

6028
The Extracurricular Activities Program

1. General Purpose

- a. The extracurricular program includes noncurricular activities which are sponsored by the school district. These activities include sports, speech, plays, Future Farmers of America, Future Business Leaders of America, music performance groups and other activities which are sponsored by the school.
- b. Extracurricular activities are an important part of the total school experience, but are secondary to the academic program and must be kept in that perspective.
- c. Extracurricular activities *do not* include:
 - i. co-curricular activities such as band and choir, in which students must participate as part of the requirements for enrollment in and receiving a grade for a particular course.
 - ii. student-initiated, non-curriculum related student groups which are permitted to hold meetings and events on school premises. These groups are not school-sponsored and are not governed by this policy or other policies and rules governing extracurricular groups.

2. Governance

- a. All extracurricular activities shall be under the exclusive governance and control of the school district. This control includes, but is not be limited to, the formation, naming, structure, operation, financing, and discontinuance of all extracurricular activities. Extracurricular activities shall not have any separate or individual existence, status, rights, or authority.
- b. Students and sponsors will be governed by all board's policies and administrative rules including the policy on field trips when traveling for extracurricular activities.

3. Student Eligibility

- a. Students are encouraged to participate in extracurricular activities. Participation shall be open to and limited to all students who are currently enrolled in the school district on a voluntary basis.
- b. Extracurricular activities may establish academic or course enrollment qualifications for participation if such qualifications are necessarily related to the purposes of the activity.
- c. Standards for scholastic eligibility for students wishing to participate in extracurricular activities shall be set by the administration and shall be consistent with at least the minimum standards provided by the NSAA.
- d. All students in grades 7-12 who participate in athletics must have a physical examination by a qualified health care provider at the student's expense.
- e. Students who wish to participate in extracurricular activities must abide by the student code of conduct, the extracurricular code of conduct and any additional rules set by the activity sponsor.
- f. Students are not eligible to participate in any extracurricular activity until they and their parents/guardians have signed the student handbook and extracurricular handbook receipt and acknowledgement.

4. **Sponsors**

- a. Each extracurricular activity must have a sponsor who is a member of the district's certificated staff or a selected community volunteer who is qualified by virtue of education, training, experience, or special interest to serve as the sponsor.
- b. The superintendent or his/her designee will assign activity sponsors. Payment to sponsors will be negotiated with the sponsor based on the terms of any applicable collective bargaining agreement, the sponsor's training and experience and any other lawful criteria. Sponsors serve in their capacity as a sponsor at the will of the superintendent, who is specifically empowered to remove an activity sponsor in the superintendent's sole discretion.
- c. Sponsors shall be required to: develop materials, activities, and a

budget; promote membership and participation; communicate with the principal or designee, staff, students, and parents; schedule meeting dates and locations; plan meaningful experiences; supervise students during activities; evaluate and make recommendations; and submit a year end report to the principal or designee.

5. Money-Raising Activities

All money-raising activities shall require authorization by a member of the school district administration and shall be subject to all other school policies. All money raised by these activities shall be governed by Policy 3005.

Adopted on: 3/14/2016

Revised on: _____

Reviewed on: _____

6029
Activity Trips

Students must travel to and from all activities in the transportation provided by the school. A student may travel home from an activity with his/her parent or guardian if the activity sponsor has personally released the student to the parents' custody along with a signed note from parent. The superintendent may prohibit any student who misbehaves while on school-sponsored trips from attending future trips.

Students must comply with the board's policies on field trips as well as the student code of conduct, the extracurricular code, and all directives of a sponsor or chaperone while on activity trip.

Adopted on: 3/14/2016

Revised on: _____

Reviewed on: _____

6030

Public Appearances of School Groups

Community-school relationships are enhanced when student groups appear at community functions. Therefore, the board encourages student groups to appear at public events, subject to the following requirements:

1. Activity sponsors must secure the permission of their building principal before booking a student group at a public event.
2. Student groups may not perform on more than one school night (Sunday-Thursday) per week.
3. Student groups may not perform at a political rally without permission from the superintendent and prior notice to parents.
4. The policies and rules that apply to field trips also apply to student group appearances in public.

Adopted on: 3/14/2016

Revised on: _____

Reviewed on: _____

6031 Emergency Exclusion

Grounds for Emergency Exclusion. Any student may be excluded from school in the following circumstances subject to the procedural provisions governing short term suspension found elsewhere in these policies or state law:

(a) If the student has a dangerous communicable disease transmissible through normal school contacts and poses an imminent threat to the health or safety of the school community; or

(b) If the student's conduct presents a clear threat to the physical safety of himself, herself, or others, or is so extremely disruptive as to make temporary removal necessary to preserve the rights of other students to pursue an education.

Any emergency exclusion shall be based upon a clear factual situation warranting it and shall last no longer than is necessary to avoid the dangers that prompted the exclusion.

Extension of Exclusion. Pursuant to the Student Discipline Act, the principal has the authority to exclude a student from school for up to five school days on an emergency basis. If the superintendent or superintendent's designee determines that it is appropriate to consider the extension of an exclusion beyond five days, such consideration shall be made according to the procedures set forth below.

Notification of Student's Parent(s) or Guardian(s). The superintendent or the superintendent's designee shall notify the student's parent(s) or guardian(s) that the principal has proposed the extension of the exclusion. If the initial notice is oral, the superintendent shall confirm it in writing.

Opportunity to Request a Hearing. The student's parent(s) or guardian(s) may submit an oral request for a hearing on the proposed extension of the exclusion within two school days of receiving the initial notice. If the initial request for a hearing is oral, they shall confirm the request in writing.

Failure to Request a Hearing. If the parent(s) or guardian(s) do not request a hearing within two school days of receiving oral or written notice, the proposed extension of the exclusion shall automatically go into effect.

Appointment and Qualifications of a Hearing Examiner. If the parent(s) or guardian(s) request a hearing, the superintendent shall appoint a hearing examiner upon receiving a request for a hearing. The hearing examiner may be any person who did not bring charges against the student, is not to be a witness at the hearing, and has no involvement in the charge.

Hearing Examiner's Notice to Parent(s) or Guardian(s). The hearing examiner shall promptly give written notice of the time, date and place of the hearing. The hearing will be held within five school days after the school district receives the initial oral or written request; provided, the hearing may be held more than five school days after receipt of the request upon a showing of good cause. No hearing will be held on less than two (2) school days' notice unless otherwise agreed to by the student's parent(s) or guardian(s) and school officials.

Continued Exclusion. If a hearing is requested, the principal may determine in his or her sole discretion that the student shall remain excluded from school until the hearing officer makes a recommendation to the superintendent.

Examination of Student's Records and Affidavits. Prior to the hearing, the student and his/her parent(s) or guardian(s) shall have the right to examine and have school officials explain the student's records and any affidavits that will be used by school officials at the hearing.

Attendance at Hearing. The hearing may be attended by the hearing examiner, the principal (or designee), the student, and the student's parents or guardian(s). The student may be represented at this hearing by a representative of the family's choice.

Student's Witness(es). The student and his/her parent(s) or guardian(s) may ask any person with knowledge of the events leading up to the sanction or with general knowledge of the student's character to testify on behalf of the student. If school personnel or other students are requested to testify by the student's parent(s) or guardian(s), the hearing officer shall endeavor to help obtain the presence of such witnesses at the hearing.

Right to Know Issues and Nature of Testimony. The student and his/her parent(s) or guardian(s) have the right to request in advance of the hearing the issues which the administration will propose in support of the extension, and the general nature of the testimony of any administrative or expert witnesses.

Presence of Student and Witnesses at the Hearing. The student and witnesses may be excluded at the discretion of the hearing examiner in accordance with state statutes. The student may speak in his/her own defense and may be questioned on such testimony, but may choose not to testify.

Sworn or Affirmed Testimony. The principal or his or her designee shall present evidence supporting the recommended extension of the exclusion. Witnesses will give testimony under oath of affirmation, and may be questioned.

Hearing Examiner's Report and Recommendations. The hearing examiner shall prepare a report of his or her findings and recommendations, and forward the report to the superintendent.

Superintendent's Decision. The superintendent will review the hearing examiner's report and determine whether to extend the exclusion. He or she shall have the decision delivered or sent by registered or certified mail to the student, student's parent(s), or guardian(s). If the superintendent decides to extend the exclusion, the extension will take effect immediately.

Adopted on: 6/11/2018

Revised on: _____

Reviewed on: _____

6032
Constitution Day Education

Each year on September 17, designated as Constitution Day, the school district will conduct a program designed to highlight the historic and continuing importance of the United States Constitution. When September 17 falls on a Saturday, Sunday, or holiday, the district will provide this program during the preceding or following week.

The program shall be implemented within the guidelines of the U.S. Department of Education and in accordance with any other applicable laws and/or regulations.

Adopted on: _____
Revised on: _____
Reviewed on: _____

Restraint and Seclusion of Students

Restraint and seclusion are behavioral interventions, not educational techniques. They are limited to exigent circumstances and situations that necessitate their use to protect the safety of the student, other students, staff and property. When used as safety intervention, they should be used as methods of last resort. When used as behavior intervention, they must be used according to the terms of this policy.

This policy does not cover interventions such as voice control, limited to loud, firm commands; time-limited ignoring of specific behaviors; brief physical prompts to interrupt or prevent a specific behavior; physical interventions which a student's health care provider has indicated are medically necessary for the treatment or protection of the individual; or other similar interventions.

I. Seclusion

A. Definition

1. Seclusion is a last resort emergency safety intervention that provides an opportunity for the student to regain self-control. Seclusion is the confinement of a student in a room or other space from which the student is physically prevented from leaving and which provides for continuous adult observation of the student.
2. A room or area used for seclusion:
 - a. must not be locked;
 - b. must not prevent the student from exiting the area should staff become incapacitated or leave that area;
 - c. must provide for adequate space, lighting, ventilation, viewing, and the safety of the student.

B. Timeout

1. Timeout is a behavior intervention in which a student, for a limited and specified time, is placed in an environment where access to positive reinforcement is unavailable.

2. Timeout should not be confused with seclusion because a student's movement in a timeout setting is not physically restricted.
 3. Timeout lies within a continuum of procedures that help students self-regulate and control their behavior.
- C. Seclusion is inappropriate for students who are severely self-injurious or suicidal.
- D. Time and Duration
1. Emergency seclusion should be used only as long as necessary to allow a student to regain control of his/her behavior, but generally:
 - a) Elementary school students – no longer than 15 minutes; and
 - b) Middle and high school students – no longer than 20 minutes.
 - c) If an emergency seclusion lasts longer than the suggested maximum time, the staff member should:
 - (1) summon additional support (e.g., change of staff, introducing a nurse or specialist, obtaining additional expertise); and
 - (2) document the need to explain the extension beyond the time limit.

E. Staff Requirements

While using seclusion, staff must:

1. involve appropriately-trained key identified personnel to protect the care, welfare, dignity, and safety of the student;
2. continually observe the student in seclusion for indications of physical distress and seek medical assistance if there is a concern; and
3. document observations.

II. Restraint

There are three types of restraint: physical, chemical, and mechanical.

- A. Physical restraint involves direct physical contact that prevents or significantly restricts a student's movement.
 - 1. Restraint is a last resort emergency safety intervention. Restraint is an opportunity for the student to regain self-control.
 - 2. This policy on physical restraint is not intended to forbid actions undertaken:
 - a. to break up a fight
 - b. to take a weapon away from a student
 - c. to hold a student briefly in order to calm or comfort
 - d. to escort a student physically from one area to another location within the school building
 - e. to assist a student in completing a task/response if the student does not resist or resistance is minimal in intensity or duration.
 - f. to hold a student briefly in order to prevent an impulsive behavior that threatens the student's immediate safety (e.g., running in front of a car).

- B. Chemical restraint is the administration of medication for the purpose of restraint.
 - 1. The school district will not, under any circumstances, engage in chemical restraint.
 - 2. Chemical restraint does not apply to medication prescribed by and administered in accordance with the directions of a physician.

- C. Mechanical restraint means the use of any device or material attached to or adjacent to a student's body that restricts normal freedom of movement and which cannot be easily removed by a student.
 - 1. Mechanical restraint does not include:
 - a. an adaptive or protective device recommended by a physician or therapist (when it is used as recommended).
 - b. safety equipment used by the general student population as intended (for example, seat belts, safety harness on school transportation).

III. Limitations in Use

- A. Seclusion and/or restraint shall not be used:
 - 1. for the convenience of staff;

2. as a substitute for an educational program; or
3. as a form of discipline/punishment.

IV. Recurring Behavior

- A. If a pattern of behavior emerges, or is anticipated, which may require the use of emergency seclusion, the school personnel must:
1. conduct a functional behavioral assessment;
 2. call a meeting of the student's IEP team to develop or revise a positive behavior intervention plan to facilitate the reduction or elimination of the use of seclusion and/or restraint
- B. Given the limited size and training of the school district's staff, students whose behavior routinely requires seclusion and restraint may not be able to be served in the school district and may require a placement out of the school district.

V. Prohibited Practices

- A. The following are prohibited under all circumstances, including emergency situations:
1. corporal punishment;
 2. the deprivation of basic needs;
 3. anything that constitutes child abuse;
 4. the seclusion of preschool children; and
 5. the intentional application of any noxious substance(s) or stimuli which result in physical pain or extreme discomfort

Adopted on: 3/14/2016

Revised on: _____

Reviewed on: _____

Concussion Awareness

The Nebraska Unicameral has found that concussions are one of the “most commonly reported injuries in children and adolescents who participate in sports and recreational activities and that the risk of catastrophic injury or death is significant when a concussion or brain injury is not properly evaluated and managed.”

The School District will:

- a. Require all coaches and trainers to complete one of the following on-line courses on how to recognize the symptoms of a concussion or brain injury and how to seek proper medical treatment for a concussion or brain injury:
 - Heads UP Concussions in Youth Sports
 - Concussion in Sports—What You Need to Know
 - Sports Safety International
 - ConcussionWise
 - ACTive™ Athletic Concussion Training for Coaches; and
- b. On an annual basis provide concussion and brain injury information to students and their parents or guardians prior to such students initiating practice or competition. This information will include:
 - 1 The signs and symptoms of a concussion;
 - 2 The risks posed by sustaining a concussion; and
 - 3 The actions a student should take in response to sustaining a concussion, including the notification of his or her coaches.

A student who participates on a school athletic team must be removed from a practice or game when he/she is reasonably suspected of having sustained a concussion or brain injury in such practice or game after observation by a coach or a licensed health care professional who is professionally affiliated with or contracted by the school. The student will not be permitted to participate in any school supervised team athletic activities involving physical exertion, including practices or games, until the student:

- a. has been evaluated by a licensed health care professional;
- b. has received written and signed clearance to resume participation in athletic activities from the licensed health care professional; and
- c. has submitted the written and signed clearance to resume participation in athletic activities to the school accompanied by written permission to resume participation from the student's parent or guardian.

If a student is reasonably suspected after observation of having sustained a concussion or brain injury and is removed from an athletic activity, the parent or guardian of the student will be notified by the school of:

- a. the date and approximate time of the injury suffered by the student,
- b. the signs and symptoms of a concussion or brain injury that were observed, and
- c. any actions taken to treat the student.

The school district will not provide for the presence of a licensed health care professional at any practice or game.

School officials shall deem the signature of an individual who represents that he/she is a licensed health care professional on a written clearance to resume participation that is provided to the school to be conclusive and reliable evidence that the individual who signed the clearance is a licensed health care professional. The school will not take any additional or independent steps to verify the individual's qualifications.

Students who have sustained a concussion and returned to school may need informal or formal accommodations, modifications of curriculum, and monitoring by medical or academic staff until the student is fully recovered. The school's "return to learn protocol" shall be the guidance provided by the Nebraska Department of Education entitled "Bridging the Gap from Concussion to the Classroom," and accompanying materials and future supplements. Nothing in this policy or the referenced protocol shall entitle a student who has sustained a concussion to an individualized plan under Section 504 of the Rehabilitation Act,

although staff will refer students who have sustained a concussion for evaluation under Section 504 as appropriate.

Adopted on: 3/14/2016

Revised on: _____

Reviewed on: _____

6035

Athletic Contest Participation by Sixth Graders

If there are fewer than 12 boys or 12 girls in the combined enrollment of the seventh and eighth grades when those grades are part of the elementary school system, sixth grade students may participate in athletic contests between schools, within a school system, or between school systems if the school administration judges that it is appropriate after taking into consideration the competition's nature and value to the students, its physical requirements and dangers, and the sixth grade students' ages, physical and mental abilities, maturity, skills, and preparation for the competition. Otherwise, pupils in kindergarten through the sixth grade may not participate in any kinds of athletic contests between schools, within a school system, or between school systems except as provided in this policy or as otherwise allowed by law. This prohibition does not apply to annual field or play days.

Adopted on: 6-12-2017

Revised on: _____

Reviewed on: _____

6036

Reading Instruction and Intervention Services

The purpose of this policy is to facilitate reading instruction and intervention services to address student reading needs, including, but not limited to, dyslexia. It is the school district's goal that each student be able to read at or above grade level by third grade.

Effective Reading Teachers. It is the intent of the school district to employ teachers for kindergarten through third grade who are effective reading teachers as evidenced by (a) evaluations based on classroom observations and student improvement on reading assessments or (b) specialized training in reading improvement.

Reading Assessment. Beginning in 2019-20, the school district will administer a reading assessment approved by the Nebraska Department of Education three times during the school year to all students in kindergarten through third grade. Exceptions to this requirement include:

- Any student receiving specialized instruction for limited English proficiency who has been receiving such instruction for less than two years;
- Any student receiving special education services for whom such assessment would conflict with the individualized education plan; and
- Any student receiving services under a plan pursuant to the requirements of section 504 of the federal Rehabilitation Act of 1973, 29 U.S.C. 794, or Title II of the federal Americans with Disabilities Act of 1990, 42 U.S.C. 12131 to 12165, as such acts and sections existed on January 1, 2018, for whom such assessment would conflict with such section 504 or Title II plan.

The first assessment must occur within the first 30 days of the school year.

Diagnostic assessments used within a supplemental reading intervention program do not require Nebraska Department of Education approval.

Deficiency Identification. Any student in kindergarten through third grade performing below the threshold level as determined by the Nebraska Department of Education shall be identified as having a reading deficiency for purposes of the Nebraska Reading Improvement Act and this policy. A student who is identified as having a reading deficiency shall remain identified as having a reading deficiency until the student performs at or above the threshold level on an approved reading assessment. Nothing in the Nebraska Reading Improvement Act or this policy shall prohibit a school district from identifying any other student as having a reading deficiency.

Supplemental Reading Intervention Program. The school district will provide a supplemental reading intervention program to ensure that students can read at or above grade level at the end of third grade. The school district may work collaboratively with a reading specialist at the Nebraska Department of Education, with educational service units, with learning communities, or through interlocal agreements to develop and provide such supplemental reading intervention programs. Each supplemental reading intervention program must:

- Be provided to any student identified as having a reading deficiency;
- Be implemented during regular school hours in addition to regularly scheduled reading instruction unless otherwise agreed to by a parent or guardian; and
- Make available a summer reading program each summer for any student who has been enrolled in grade one or higher and is identified as continuing to have a reading deficiency at the conclusion of the school year preceding such summer reading program. The summer reading program may be held in conjunction with existing summer programs in the school district or in a community reading program not affiliated with the school district or may be offered online.

The supplemental reading intervention program may also include:

- Reading intervention techniques that are based on scientific research and best practices;
- Diagnostic assessments to frequently monitor student progress throughout the school year and adjust instruction accordingly;
- Intensive intervention using strategies selected from the following list to match the weaknesses identified in the diagnostic assessment:
 - Development in phonemic awareness, phonics, fluency, vocabulary, and reading comprehension;
 - Explicit and systematic instruction with detailed explanations, extensive opportunities for guided practice, and opportunities for error corrections and feedback; or
 - Daily targeted individual or small-group reading intervention based on student needs as determined by diagnostic assessment data subject to planned extracurricular school activities;
- Strategies and resources to assist with reading skills at home, including parent-training workshops and suggestions for parent-guided home reading; or
- Access to before-school or after-school supplemental reading intervention with a teacher or tutor who has specialized training in reading intervention.

Parent/Guardian Notification. The school will give notice in writing or by electronic communication to the parent(s) or guardian(s) of any student identified as having a reading deficiency within 15 working days of such identification that the student has been identified as having a reading deficiency and that an individual reading improvement plan will be established and shared with the parents or guardians.

Reading Improvement Plan. Any student who is identified as having a reading deficiency will receive an individual reading improvement plan no later than 30 days after the identification of the reading deficiency. The reading improvement plan may be created by the teacher, the principal, other pertinent school personnel, and the parents or guardians of the student and shall describe the reading intervention services the student will receive through the supplemental reading intervention program to remedy the reading deficiency. The student must receive reading intervention services through the supplemental reading intervention program until the student is no longer identified as having a reading deficiency.

Reading Progress. Each student in kindergarten through third grade and his or her parent(s) or guardian(s) will be informed of the student's reading progress within a reasonable time after the school district receives the results from the student's approved reading assessment.

Adopted on: 6/11/2018

Revised on: _____

Reviewed on: _____

**MADISON
ELEMENTARY
SCHOOL**



**2020-2021
PARENT-STUDENT
POLICY HANDBOOK**

Last updated: May 2020

Table of Contents			
Principal's Greeting	3	Homeless Coordinator	10
Mission Statement	3	Homework	10
Staff Directory	3	Insurance	10
Asbestos Notification	4	Internet Policy	10
Attendance	4	Library	11
Attendance-Excessive Absences	4	Lunch	11
Attendance-Reporting Absences	4	Lunch-Rules	11
Attendance-Early Checkout	5	Lunch-USDA Nondiscrimination	11
Bicycles, Skateboards, Roller Blades	5	Make-up Work	12
Breakfast Program	5	Parent-Teacher Conferences	12
Bus Rules	5	Playground/Recess Information	12
Calls to Police	6	Police Interviews	12
Child Find	6	Pre School	13
Classroom Schedule	7	Progress Reports	13
Complaints About School Personnel	7	Multi-Tier System of Support (MTSS)	13
Conduct and Discipline	7	Safety	13
Dress Code	8	School Closing/Cancellation	13
Drop-off and Pick-up of Students	8	School Hours	14
Drug and Alcohol Education Programs	8	School Property	14
Electronic Equipment	8	Staff Qualifications	14
Entrance Requirements	8	Student Photos	14
Field Trips	9	Student Valuables	14
Guidance and Counseling Services	9	Supplies	14
Health Services	9	Telephone Calls	14
Health Services-Accidents and Injuries	9	Title I compact	15
Health Services-Medication	9	Visiting School	16
High-Ability Learners Program (HAL)	9	Volunteers	16
		Notice of Non-Discrimination	16

Welcome to another wonderful year at Madison Elementary School! Our staff is excited to work with each student, helping them to meet the challenges that come with being a child in an ever-changing world. Please refer to this handbook when you have questions throughout the school year. If you have any questions that cannot be answered, please contact me at kkush@esu8.org or 402-454-2656.

I wish you a successful school year and thank you for choosing Madison Elementary School!

Go Dragons!!

Mrs. Karla Kush
Elementary Principal

MADISON PUBLIC SCHOOL MISSION STATEMENT

The mission of Madison Public Schools is to prepare students to be competent, confident, productive and responsible citizens.

MADISON ELEMENTARY STAFF

Superintendent	Alan Ehlers
Principal	Karla Kush
Preschool	Jessica Ternus, Rachel Harrimon
Kindergarten	Randi Ernest, Kari Frauendorfer
First Grade	Hannah Rice, Erin Mackey
Second Grade	Error! Bookmark not defined. Brisa Calderon, Erin Reeves
Third Grade	Jane Lewis, James Cooper
Fourth Grade	Nicole Babutzke, Shane Prather
Fifth Grade	Collin Crilly, Vicky Jones
Special Education	Audrey Pollreisz, Nicole Unkel, Leigh Ann McCartney
English Language Learners (ELL)	Regan Ramaekers
Title 1	Kay Wehrle
Vocal Music	Teresa Wagner
Director of Curriculum, Assessment and Learning	Travis Jordan
Physical Education	David Kaps
School Counselor	Teryn Rother
Media/Technology	Trish Braithwait
Paraprofessionals	Robin Flaugh, Jayne Freudenburg, Brooke Hanson, Cara Lapour, Lydia Tinajero, Marilyn Samuelson, Marilu Orozco, Rosa Uribe, Niko Gronenthal
School Nurses	Lisa Holoubek, Janet Pfeifer
Speech Therapist	Amanda Ford
School Psychologist	Cathy Fiala
Secretary	Enriqueta Saldana
Librarian	Trish Braithwait
After School Program Director	Natilli Gubbels
Child Care Director	Mariela Millan
Custodian	Troy Ganskow

The following pages will be devoted to a majority of the policies and rules that govern Madison Elementary. It is impossible to list the unique circumstances covered by every policy. The rules set in this handbook regarding student conduct are enforced throughout the school and on all school property. This also includes all extracurricular events both home and away. No person who falls under the jurisdiction of Madison Public School District shall be discriminated against on the basis of sex, race, religion, or physical or mental handicap.

ASBESTOS NOTIFICATION

Current Federal Regulations require all schools inventory asbestos containing materials (ACM) and develop a management plan to identify and control ACM in their buildings. ACM has been identified in the elementary and junior high buildings. The presence of asbestos in a building does not mean that the health of building occupants is necessarily endangered. As long as asbestos-containing material (ACM) remains in good condition and is not disturbed, exposure is unlikely. When building maintenance, repair, renovation or other activities disturb ACM, or if it is damaged, asbestos fibers are released creating a potential hazard to building occupants. The plan for the Madison County District #1 School has been submitted to the Governor of Nebraska and is now available for inspection (without cost) to the general public, teachers, and other school personnel. The plan will be made available within five working days after receiving your request. For further information contact Alan Ehlers, Superintendent (454-3336). The school may charge for copies of the plan.

ATTENDANCE

Nebraska State Statue (79-201) requires that all students between the ages of 6-18 attend school. It is the responsibility of the parent/guardian to see that the student is at school at the appropriate time in a proper state of health and cleanliness. The school district is required by law to notify juvenile justice officials when excessive absences occur. Madison Elementary School believes that punctual and regular attendance is extremely important. It is one of the most important factors in determining school success. Please schedule appointments (dentist, doctor, etc.) for non-school days and plan vacations for school breaks and summer vacation. Making sure that your child misses as little school as possible is the most important thing that you can do to support their education. There is a strong relationship between attendance and student achievement at all levels of education. For any elementary student that misses more than 10 days of school in a single school year, a meeting must take place between the child's parent(s)/guardian(s) and the Elementary Principal before the student is promoted to the next grade level.

ATTENDANCE-EXCESSIVE ABSENCES

Students arriving after 8:00 am MUST obtain a tardy pass from the office.

All absences and tardies will be counted in the total time of missed school. Our policy states that when a student is absent:

- **5 Days**— For any time a student misses a total of five (5) days (or the hourly equivalent), the parent will be contacted and notified of the total number of absences, the dates of these absences, and the time period of accumulation.
- **10 Days**—For any time a student misses a total of ten (10) days of school (or the hourly equivalent), the parent shall be contacted and notified of the total number of absences and the current policy relating to attendance at school will be provided. The county attorney may be notified of the absences.
- **15 Days**—When a student has missed a total of fifteen (15) school days (or the hourly equivalent), the parent shall be notified of the total number of absences and the current policy relating to attendance at school will be provided. The county attorney may be notified of the absences.
- **20 Days**—When a student misses a total of twenty (20) school days (or the hourly equivalent), the parent shall be notified of the total number of absences. The county attorney WILL be notified of on-going attendance concerns.

Students missing 20 days of school or more in an academic year may be retained.

ATTENDANCE-REPORTING ABSENCES

Parents should call the school office on or before the day of an absence. Phones will be answered at the elementary school after 7:30 am. When contacting the school please give the following information:

- 1) Name and grade of the student
- 2) Reason for absence
- 3) Name and relationship of the person making the call

If a child is absent and we do not receive notification, the school will contact the parents. If the school is unable to contact the parents, the child will be considered truant.

Students should make up assignments in advance for known future absences. **Parents who wish to get assignments for a child who is ill must call the office before 9:00 am;** assignments can be picked up in the office after 2:00 pm. This allows ample time for teachers to prepare materials and books.

ATTENDANCE-EARLY CHECKOUT

If it is necessary for your child to leave school early during the day, you must come to the office and personally sign him/her out of school listing the date, time and reason for leaving. This is necessary for us to monitor attendance.

BICYCLES, SKATEBOARDS, ROLLER BLADES AND SCOOTERS

Bicycles must be parked in the racks provided or set in line with the racks. To prevent theft, bicycles should be padlocked. Skateboards, roller blades and scooters are not permitted.

BREAKFAST and LUNCH PROGRAM

Madison Elementary provides a breakfast program for students. Breakfast will be served daily from 7:15 a.m. to 7:50 a.m. Students arriving after 7:50 a.m. will not be able to eat a hot school breakfast, so please ensure that your child arrives well before this time if they wish to eat in the morning. If a student qualifies for free lunch, breakfast is free. If a student qualifies for reduced lunch, the cost of breakfast is 30 cents and the cost of lunch is 40 cents. The regular price of breakfast is **\$1.80** and the regular price of lunch is **\$2.95**. An adult breakfast is **\$2.55** and an adult lunch is **\$3.95**. If you are coming to eat lunch with your child, please call the school ahead of time so the kitchen can be notified.

BUS RULES

We believe all students can behave appropriately and safely while riding the school bus. We will not tolerate any student that impedes the drivers from doing their job or preventing other students from having safe transportation.

Rules:

1. Obey and show respect to the driver
2. Remain in your seat at all times
3. No pushing, shoving, fighting, or throwing objects at any time
4. No smoking, lighting matches or lighters, chewing tobacco, sunflower seeds, or spitting
5. Silence at railroad tracks
6. No swearing or use of obscene language or gestures
7. Respect property of school and others.
8. No hanging any objects or parts of body out the windows
9. Follow all rules in the parent-student handbook

Possible Consequences:

1. Driver verbally warns student
2. Driver reports incident to principal. Parents contacted
3. Short-term suspension of riding privileges
4. Long-term suspension of riding privileges
5. Permanent removal of riding privileges

Steps may be skipped depending on the seriousness of the offense. The Elementary Principal reserves the right to revoke bus privileges for any student that does not comply with the above rules.

CALLS TO POLICE

Nebraska State Statute, Section 79-293 requires the school principal to notify as soon as possible the appropriate law enforcement authorities of any act of a student, which constitutes grounds for long-term suspension, expulsion or mandatory reassignment under Section 79-267, AND is a violation of the Nebraska Criminal Code. School district administrators will therefore notify local law enforcement officers in the event that any of the following student violations occur. Parents will be informed by the building principal that such notice to the police has been made, as soon as reasonably possible.

1. Violence
 - Use of weapon
 - Threat, force, intimidation or coercion (students/staff)
 - Punches thrown by either party which constitute a substantial interference with school purposes
2. Property Damage
 - Theft (value of \$25.00 or more)
 - Repeated violations of theft or damage
3. Personal Injury
 - Physical injury or emotional harm
 - Consider intent to injure
 - Repeated intent to injure offenses
4. Threatening to Obtain Money
 - Clear extortion (succeeded in completing transaction)
 - Repeated extortion attempts
5. Weapons
 - Firearms or knives
 - Other items intended to be used as weapons
6. Controlled Substance
 - All incidences and/or limitations as outlined in law
 - Drug paraphernalia with drug residue
7. Public Indecency
 - Exposing self
8. Sexual Assault
 - Any sexual assault
 - Any attempted assault on and off school property
9. Danger to Student
 - As stated in law (fire code violation, bomb threat)
10. Repeated Violations that interfere with school purposes

CHILD FIND

The Madison Public Schools have the responsibility to identify, locate and evaluate all children (birth through age 21) with disabilities regardless of the severity of their disabilities, and who are in need of special education and related services. If you have questions or concerns about a child, please contact Alan Ehlers, Superintendent, (454-3336) concerning the district's referral process.

CLASSROOM SCHEDULE

The school day is from 8:00 am to **3:20** pm. Students who are not eating school breakfast in the morning are not to be in the building before 7:30 am. Students will be escorted to class at approximately 7:55 am. Students should leave promptly after school unless they have permission or are part of a school approved activity.

Vocal Music, Physical Education, Guidance, Library, and all specialty classes are arranged, through cooperation with the homeroom teacher on specific days. The homeroom teacher can give you this information when requested. Madison Elementary is committed to providing a balanced approach towards learning in all areas of study.

COMPLAINTS ABOUT SCHOOL DISTRICT PERSONNEL

Madison Public Schools is committed to placing the needs of our students and their families first in our efforts to provide a quality educational program. However, if you encounter a conflict with any school personnel, we encourage you to resolve it directly with them or their immediate supervisor at the building level. If this is not successful, you may complete and file a "Complaint About School District Personnel" form with the building principal. An Individual filing such a complaint will be contacted by the building principal within three (3) school days following receipt of the complaint to begin responding to his or her concerns.

CONDUCT AND DISCIPLINE

Good discipline is needed in the schools if an effective learning environment is to be developed. Students are expected to behave in an orderly and appropriate manner. Students have the freedom and encouragement to express their individuality. That freedom cannot intrude upon or endanger the freedom of others, nor can it interfere with our teaching or other students' learning. Disobedience or open defiance of school regulations and authority shall constitute sufficient cause for disciplinary action.

With cooperation from the parents, the Madison Elementary School faculty will encourage students to take responsibility for their actions. Discipline is an opportunity to learn. We hope to help each child in learning:

1. Respect for school property, as well as the property of fellow students.
2. Respect in word and conduct towards all people.
3. Respectful and clean language.
4. Respect for the welfare and happiness of others.

Discipline issues at Madison Elementary will be handled using the Behavior Intervention Support Team or BIST model. The BIST model has three GOALS FOR LIFE:

- 1) I can be productive and follow directions even if I am mad or have an overwhelming feeling.
- 2) I can be productive and follow directions even when others are NOT okay
- 3) I can be productive and follow directions even when I don't want to.

At Madison Elementary it is ALWAYS OK to do your best and ask for help!

At Madison Elementary it is NEVER OK to be hurtful or disruptive. Students that demonstrate patterns of disruptive or hurtful behaviors will be supported through a combination of the BIST model and school discipline.

*****Please note that board policy 5035 also talks about suspensions and expulsions that may be used if the principal deems necessary as a disciplinary action. If you have questions about this please contact the Elementary Principal.**

DRESS CODE

We want students at Madison Elementary School to take pride in their appearance. Appearances are expected to be clean, neat, modest, and in good taste. Appearances that detract from the learning environment will not be permitted. Students will be required to change clothes immediately if this occurs. Students will wear clean, comfortable clothing that is in good taste. Derogatory sayings, sexual innuendos, anti-American implications, beer, liquor, tobacco pictures/advertisements, or profanity is not permitted.

- Hats are not permitted inside the school building.
- Shoes must be worn at all times.
- Students are expected to adhere to the dress code when attending school and extra-curricular activities.
- Students will not be allowed to go out for recess if shorts are worn on cold days.
- When sandals are worn, students must bring tennis shoes to be worn at recess and during PE class.
- When snow boots are worn, students must bring other shoes to wear indoors throughout the day.

The administration reserves the right to make final decisions regarding the dress code.

DROP-OFF AND PICK-UP OF STUDENTS

*Students will be allowed to enter the building beginning at 7:15 each morning from the main entrance on the north side of the building.

*Students will be dismissed ONLY from the WEST doors. Students are to exit these doors and then either walk home or go to their designated safe zones while waiting to be picked-up.

*For the safety of students who are not walking home, they will not be allowed to leave their designated safe zone, unless accompanied by an adult or someone designated by their parents.

Enter the drop-off/pick-up lane from the south from East 9th Street and exit on the north side of the school onto East 8th Street.

The lane nearest the school is for cars dropping off or waiting for students, the lane farthest from school is to remain clear for vehicles to exit.

Do not park across the street on the north side of 8th Street. This is against the law!

Do not park on the one-way street west of the school. This is against the law!

The south and west parking lot is for staff parking only.

Students walking home must use sidewalks and crosswalks.

Please watch for our children, the safety patrol and the staff on duty! We want Madison Elementary School to be a safe place for everyone!

DRUG AND ALCOHOL EDUCATION PROGRAMS

Madison Public Elementary does not condone the use of illicit drugs or alcohol and the unlawful possession, which is wrong and harmful. Possession or use of drugs or alcohol is prohibited by students on school premises or at any school function. Appropriate educational and prevention programs are addressed within the curriculum.

ELECTRONIC EQUIPMENT

Electronic devices such as **headphones/speakers, video games, cell phones, iPads/**tablets are prohibited during school hours unless given permission by a teacher.

ENTRANCE REQUIREMENTS

A child must reach the age of five years on or before July 31st of the current school year to be eligible to enter kindergarten in the public school. A child must reach the age of four years on or before July 31st of the current school year to be eligible to enter the 4-year-old preschool program in the public school. A child must reach the age of three years on or before July 31st of the current school year to be eligible to enter the three-year old preschool program. At registration, parents must provide proof of the child's correct age.

FIELD TRIPS

Throughout the year, students will take field trips. Field trips are arranged for educational value to students and are an extension of classroom learning. Field trips are taken by grade; each grade is allowed to take one field trip each semester (or no more than two trips in an academic year). Field trips within the Madison's city limits are excluded. Before each field trip, the teacher will send a reminder home. If you do not wish for your child to attend that particular field trip, you should contact the school.

GUIDANCE AND COUNSELING SERVICES

We have an elementary school counselor available to assist our students. An elementary counselor serves in a variety of roles. The counselor provides whole group guidance classes on topics related to building positive relationships, friendships, and overall positive mental attitudes of students towards themselves and others. The counselor is also able to meet with small groups of students or individuals to work on social/emotional skills or discuss individual issues. Individual and small group sessions are confidential unless the student expresses harm to themselves or others. By signing this handbook parents/guardians acknowledge and approve of their child being seen by the elementary school counselor. The counselor may engage children in any activities he or she deems appropriate in encouraging positive, lasting behavior change.

HEALTH SERVICES

Screenings are completed annually by the school nurse. If there is a referral notice sent home from the results of these tests, please give attention to it and call the nurse with your questions.

- If your child has a fever, vomits, or has diarrhea, please keep him/her at home at least 24 hours after symptoms subside. Please do not give your child fever-reducing medication and send him/her to school; he/she is still contagious.
- **Chicken pox** is highly contagious. Children will be removed from school and will not be allowed to return until 5 days from the time of the break out.
- **Head lice** must be treated with a special shampoo. Children will be removed from school but can return the day following the shampoo. The special shampoo will need to be repeated again in 7 days.
- **Impetigo** is highly contagious. Children will be removed from school but can return as soon as an antibiotic salve is applied to the area.
- **Pink eye** is highly contagious. Children will be removed from school but can return as soon as he/she is on medication prescribed by your doctor.
- **Ringworm** is highly contagious. Children will be removed from school but can return as soon as he/she is on medication prescribed by your doctor.

HEALTH SERVICES-ACCIDENTS AND INJURIES

All major injuries sustained by students while in attendance at school must be reported to the office immediately. Appropriate forms will be completed and a copy will be sent home. Parents will be notified to pick up their child for home or doctor's care, if necessary.

HEALTH SERVICES-MEDICATION

Any parent who wishes school personnel to administer medication to his/her child during the regular school day must comply with certain regulations.

1. Medication must be left at the office accompanied by a permission form signed by a parent/guardian. These forms are available in the office.
2. All medications must be in a container properly labeled with the child's name, doctor's name, medication name and directions for administering. Ask your pharmacist for an extra bottle for your at-school prescriptions.

HIGH ABILITY LEARNER (HAL) PROGRAM

The HAL Program consists of a number of different opportunities that allow intellectually gifted and creatively talented students to experience a variety of challenging and stimulating activities and projects. Students are selected for this program based upon NWEA test scores and teacher recommendations. The High Ability Learner (HAL) program will meet approximately once per week.

HOMELESS COORDINATOR

The McKinney-Vento Act defines homeless children as "individuals who lack a fixed, regular, and adequate nighttime residence." The act provides examples of children who would fall under this definition:

- Children and youth sharing housing due to loss of housing, economic hardship or a similar reason
- Children and youth living in motels, hotels, trailer parks, or campgrounds due to lack of alternative accommodations
- Children and youth living in emergency or transitional shelters
- Children and youth abandoned in hospitals
- Children and youth awaiting foster care placement
- Children and youth whose primary nighttime residence is not ordinarily used as a regular sleeping accommodation (e.g. park benches, etc)
- Children and youth living in cars, parks, public spaces, abandoned buildings, substandard housing, bus or train stations
- Migratory children and youth living in any of the above situations

The homeless coordinator for Madison Public Schools is Leticia Rodriguez. She can be reached at Madison High School (454-3336). Please contact Leticia Rodriguez or a school administrator if you have concerns.

HOMEWORK

Homework may include memorization, practice exercises, outside reading, projects or family activities. According to teachers and researchers, the major purposes of homework are:

1. To practice and reinforce skills or concepts introduced in class.
2. To prepare for in-class discussion or experiments. Activities may include collecting materials or information to bring to class, studying vocabulary or practicing math facts.
3. To expand, enrich or explore subjects of personal interest and to allow individual creative forms of expression, through additional readings, research or projects.

Special situations at any grade level may warrant deviations from these purposes. Remember, homework is a joint activity between home and school.

Initiations and Hazing

Initiations and hazing by members of classes, clubs, athletic teams, or any other organization affiliated with the district are prohibited except as otherwise permitted by this policy. Any student engaging in hazing or non-approved initiations is subject to discipline as permitted by policy and law.

INSURANCE

Madison Public Schools will send home information about the Kids Connect insurance program at the beginning of the year. Parents may purchase insurance for their children if they so desire. The school district **does not** provide any health or accident insurance for our students.

INTERNET POLICY

The Board of Education will provide Internet services to teachers and students to promote educational excellence in the Madison Public School district by facilitating resource sharing, innovation and communication.

Students are responsible for good behavior on the school network, just as they are in classrooms, on the playground, in the lunchroom, and in the hallways.

1. Do not tell anyone your password
2. Do not waste paper. Print only what you need.

To teach appropriate strategies for accessing information for research and education, this school district offers access to Internet and other computer networks, subject to the rules and procedures to be set by the Board of Education, or its designee.

Our district utilizes a “filter” through the Educational Service Unit that blocks inappropriate sites from student view. Students are responsible for appropriate behavior when using the Internet. Students misusing the Internet will be subject to consequences including warnings, loss of privileges, notification of parents, or referral to proper authorities for disciplinary and/or legal action.

LIBRARY

Our library offers a variety of media to interest each child, as well as library activities to stimulate use of the library and knowledge of library procedures and classifications. The library will be open during school hours. Students are responsible for any books or other materials checked out from the library. Most items may be checked out for two weeks. Students are responsible for library materials. Books or other materials that are lost or damaged will be paid for by the student. Charge is based on loss or extent of the damage to the materials. With everyone’s cooperation, we look forward to another enjoyable year. We hope to capture each child’s interest and make every visit to the library an exciting and stimulating experience.

LUNCH

Nutritious meals are served each school day. Breakfast and lunch money may be dropped off in the office or library. Please indicate on the check or the envelope the amount of money designated for each child.

Students who regularly bring sack lunches may purchase milk with their noon meal. Student breakfasts are **\$1.80**, lunches are **\$2.95** each and milk is 35 cents each. **All prices are subject to change.** We use the Accu-Scan System to track student accounts. Our system does not allow students to charge milk or lunch; students receive payment reminders when account balances are low.

Parents are invited to come to school for lunch during the school year. Adult lunches are **\$3.95**. Please contact the office in advance to make a reservation.

LUNCH-RULES

HOT BREAKFAST AND LUNCH PROCEDURES

Madison Public Schools offers a healthy breakfast and lunch every school day. Student meals may be purchased in the office at a cost determined by the District.

1. Meals must be purchased prior to the start of school in the mornings. The office opens at 7:30 AM daily.
2. All students will be required to eat in the commons area.
3. Each day students are offered the complete lunch which will include a main meat dish
4. During lunch period, all students need to leave books in their lockers, classrooms, or on the tables/stage in the commons.
5. Students may bring a sack lunch, but no pop or restaurant food may be brought into the commons area during school lunch time.

NATIONAL SCHOOL LUNCH & BREAKFAST PROGRAM Non-Discrimination Statement

In accordance with Federal civil rights law and U.S. Department of Agriculture (USDA) civil rights regulations and policies, the USDA, its Agencies, offices, and employees, and institutions participating in or administering USDA programs are prohibited from discriminating based on race, color, national origin, sex, disability, age, or reprisal or retaliation for prior civil rights activity in any program or activity conducted or funded by USDA.

Persons with disabilities who require alternative means of communication for program information (e.g. Braille, large print, audiotape, American Sign Language, etc.), should contact the Agency (State or local) where they applied for benefits. Individuals who are deaf, hard of hearing or have speech disabilities may contact USDA through the Federal Relay Service at (800) 877-8339. Additionally, program information may be made available in languages other than English.

To file a program complaint of discrimination, complete the USDA Program Discrimination Complaint Form, (AD-3027) found online at: <https://www.ascr.usda.gov/ad-3027-usda-program-discrimination-complaint-form> and at any USDA office, or write a letter addressed to USDA and provide in the letter all of the information requested in the form. To request a copy of the complaint form, call (866) 632-9992. Submit your completed form or letter to USDA by: (1) Mail: U.S. Department of Agriculture Office of the Assistant Secretary for Civil Rights, 1400 Independence Avenue, SW, Washington, D.C.20250-9410; (2) Fax: (202) 690-7442; or (3) Email: program.intake@usda.gov this institution is an equal opportunity provider.

MAKE-UP WORK

Generally, the student will have the same number of school days to complete make-up work, as he/she was absent, if the absence was excused. For example, if he/she is absent for three days, the student will have three school days to turn in the make-up work. The classroom teacher(s) will give special consideration to extenuating circumstances. If you know of an absence in advance, contact your child's teacher to arrange for work ahead of time.

PARENT-TEACHER CONFERENCES

A vital link in complete communication between families and the school is through parent-teacher conferences. Special time is scheduled in the fall and in the winter during which teachers and families can discuss the progress of the student. It is quite important for parents to attend all conferences. Additional conferences may be scheduled anytime by teachers or parents. Please call the office to schedule an appointment.

PLAYGROUND/RECESS INFORMATION

Weather permitting, all students will go outside each day throughout the school year for exercise and fresh air. Students are expected to wear appropriate clothing and boots for cold and wet weather. Students are expected to wear coats, mittens, gloves and caps or hoods in cold weather.

Students will not go outdoors under the following weather conditions:

1. When it is raining or snowing heavily
2. When the wind chill index or Fahrenheit temperature is below zero (at the discretion of the supervisor between 0-10 degrees)
3. When lightning or an approaching storm is in the immediate area

Individual exceptions to outdoor recess are:

1. **Written** parent request to keep the child indoors due to illness (for up to one school week or five school days); the students staying indoors will have time to complete homework or rest; and
2. **Written** doctor requests to have child remain indoors for designated period of time

POLICE INTERVIEWS

Law enforcement or juvenile officers will not be allowed to interview students at school during the school day without the school official making a reasonable effort to contact parents. The building principal may grant exceptions to the above to probation officers who desire to meet with students who are already on probation and/or representatives of Social Services who are accompanied by law enforcement officers. If physical violence or a criminal act occurs at school, the school principal or designee may call the police without first receiving authorization from parents.

PRE-SCHOOL

At the beginning of the school year all pre-school parent(s)/guardian(s) will receive a copy of the Little-Dragons pre-school handbook.

PROGRESS REPORTS

Progress reports will be sent home each quarter. Please review report cards for information on academic progress, attendance (days missed each quarter), tardies (each quarter). Several of our classes are performance-based and grading in those subjects may reflect that concept. Please visit with PE, music and band teachers to discuss scoring and grading.

MULTI-TIER SYSTEM OF SUPPORTS (MTSS)

Madison Elementary School is committed to helping all children learn and succeed. Some children learn easily in the classroom without extra support. But some children struggle to learn and need extra help. MTSS is one way we can make sure all children learn and succeed. MTSS is a process that has many steps. Each step is designed to make sure all children are getting the instruction and support they need. Each child's progress is monitored. The results are used to help make decisions about instruction and which children might need extra help. Madison Elementary is currently using the MTSS process to help children who are struggling with reading.

SAFETY

For each student's safety, the doors to the building will be locked at all times. Please use the doorbell at the north entrance to contact the office and be admitted to the building.

All elementary students MUST obey the safety patrol. Fifth grade students are selected for safety patrol and are stationed at specified crossings near the elementary school: the front door, west door, west door crosswalk, and stop sign crosswalk. The purpose of the program is to provide assistance for the children's safe crossing at intersections. Safety patrol members are on duty each day from 3:15-3:30 pm. Written permission is required for a student to serve in this capacity.

If bicycles are ridden to school, they must be parked in the racks located on the west side of the elementary building. To avoid theft, bicycles should be padlocked. Bicycles will be walked across all intersections. Skateboards and roller blades are not to be used on school property.

The following guidelines promote the continuing effort to improve safety:

1. Walk your bike on school grounds.
2. Ride by yourself. Use a backpack to secure your belongings; another person or carrying packages on your bike can block your vision and throw you off balance.
3. Keep control while on your bike—no tricky steering, weaving or racing.
4. Stay on the right side of the street, close to the curb. Move with traffic and watch for parked cars turning out or car doors opening suddenly.
5. Ride your bike in single file when riding with others; follow a full bikes' length behind the driver in front of you.
6. Steer with both hands on the handle except to signal when you are turning, stopping or leaving the curb.
7. Cross only at intersections.
8. Come to a complete stop at all stop signs and yield signs.
9. Stop, look and listen before entering a street from a sidewalk, driveway or alley; drivers may not see you.
10. Be ready to put on the brakes at intersections. Get off your bike and walk your bike across the street.
11. Let people on foot and other vehicles go first when they are about to cross in front of you.

SCHOOL CLOSING/CANCELLATION/LATE-START/EARLY DISMISSAL

Students, parents/guardians will be informed through instant school messenger that school has been cancelled. They may also listen to radio stations WJAG 780 AM, KNEN 94.7 FM, KEXL 106.7 FM, KLIR 101.1 FM, KKOT 93.5 FM, KUSO 92.7 FM, KTTT 1510 AM, KZ100 100.3 FM, and KPNO 90.9 FM or watch television stations channel 4 KTIV and channel 10 KOLN/KGIN will also carry the announcement. If you have access to the Internet, you may also use the following websites: www.kexl.com, www.us92.com, www.cancellations.com, or www.kolnkgin.com. The Madison Public School's Facebook page will also have it announced.

The decision whether or not to have school is generally made between 5:00 and 6:00 am on the day of bad weather. If there is a late start, students will be allowed in the building fifteen minutes before classes begin. Typically, a late start will be at 10:00 a.m. unless otherwise noted.

SCHOOL HOURS

School hours are from 8:00 a.m. to 3:20 p.m. daily. Early dismissals will be announced ahead of time. Elementary office hours are from 7:30 a.m. to 4:00 p.m. daily. You may contact the school during those hours by phone at 454-2656 or by fax at 454-3978.

SCHOOL PROPERTY

Since all of us take pride in our school building, each person is expected to treat its contents with respect. Everyone needs to help keep our school neat and clean. Please remember any student who damages school property will face disciplinary actions and restitution must be made. All students, regardless of their family's economic status, are financially responsible for damaged textbooks and school equipment.

Lockers and desks are school property; therefore, the administration reserves the right to search lockers and desks at any time. The students should have no expectation of privacy.

STAFF QUALIFICATIONS

The No Child Left Behind Act 2001 and now Every Student Succeeds Act 2015 gives parents the right to get information about the professional qualifications of their child's classroom teachers. Upon request, Madison Public Schools will provide parents with the following information about their child's classroom teacher:

- Whether the teacher has met State qualifications and licensing criteria for the grade levels and subject areas in which the teacher provides instruction.
- Whether the teacher is teaching under an emergency or provisional teaching certificate.
- The baccalaureate degree major of the teacher. You may also get information about other graduate certification or degrees held by the teacher, the field of discipline of the certification or degree.

We will also, upon request, tell parents whether their child is being provided services by a paraprofessional and, if so, the qualifications of that individual. The request for information should be made to the administrator in your child's school building. The information will be provided to you in a timely manner. Madison Public Schools will give timely notice to you if your child has been assigned, or has been taught for four or more consecutive weeks by, a teacher who does not meet the requirements of the "No Child Left Behind Act of 2001."

STUDENT PHOTOS

It is required by Board Policy Madison Public Schools that parents be informed of the potential use of student's name, photograph and other likeness, or related information in public education and information activities. Such activities may include, but are not limited to newspaper articles, brochures, slideshows, videos, web pages, podcasts, and blogs. Information and photos will be released unless parents specifically request in writing to the principal that their child(ren) should not be included.

STUDENT VALUABLES

Students, not the school, are responsible for their personal property. Students are cautioned not bring large amounts of money or items of value to school.

SUPPLIES

A list of suggested school supplies for each grade level is available at the school office. Many parents wish to provide the items on this list to assist the school in the education of their children.

TELEPHONE CALLS

School telephones are for business purposes. Personal calls are discouraged. If anyone calls for a student or teacher while they are in class, we will deliver a message. **Students may use the telephone for emergencies only. Students must make after school plans before entering the building in the morning.**

Title I: School-Parent-Child Compact

The Madison Public School and the parents of students participating in activities, services, and programs funded by Title I have jointly developed this Compact which outline how the parents, school staff, and students will share the responsibility for improved student academic achievement and the means by which the school and parents will build and develop a partnership to help children achieve the State's high standards.

School Responsibilities:

The faculty and staff of the District, will:

- Provide high quality curriculum and instruction in a supportive and effective learning environment to enable children to meet the challenging State academic standards.
- Consider the promises made in the Compact at parent-teacher conferences.
- Provide parents with frequent progress reports pursuant to district policy.
- Communicate and work with families to support students' learning.

Parent Responsibilities:

The parent(s) will support their child's learning in the following ways:

- Communicate and work with teachers and school staff on an ongoing basis to be involved and support my child's learning.
- Value and support my child's attendance at school.
- Ensure that homework is completed.
- Promote positive use of my child's extracurricular time.
- Participate in parent groups that support the district's students.
- Endeavor to stay informed about my student's progress and request updates as needed.

Student Responsibilities:

The student will share the responsibility to improve his or her academic achievement in the following ways:

- Cooperate with my teachers in school and be responsible for my behavior.
- Complete all of my homework assignments on time.
- Participate to the best of my ability in all of my classes.
- Participate in extracurricular activities which will help me become a better student and stay active in my school and community.
- Let my teachers and family know when I need help.

VISITING SCHOOL

Parents and/or guardians are always welcome as school visitors. We require that all visitors have prior permission to visit from the teacher and/or principal. All visitors should check in at the school office before visiting the classroom. A visitor's identification badge will be issued to ensure the safety of our students. Children are not permitted to visit unless accompanied by an adult. All school doors will be locked from the start of school through the after-school program.

If your child wishes to bring a pet to school to share, he/she must have prior permission from the teacher and principal. An adult must accompany the pet to school and the pet must be returned home immediately after the sharing time.

VOLUNTEERS

Parents and other citizens are encouraged to volunteer their time and talents to the schools. Volunteer services range from helping in the elementary library to assisting in the individual classrooms. If you would like to volunteer, please contact your school or your child's teacher. Volunteers are asked to sign in at the office

NOTICE OF NONDISCRIMINATION

The Madison Public School District does not discriminate on the basis of race, color, national origin, gender, marital status, disability, or age in admission or access to, or treatment of employment, in its programs and activities. The following person has/have been designated to handle inquiries regarding complaints, grievance procedures or the application of these policies of nondiscrimination:

Title: Superintendent of Schools

Address: Madison Public School

P O Box 450

Madison, Nebraska 68748 Phone #:

402-454-3336

If parents, employees and students do not feel that their complaints regarding Title IX, Title VI, Section 504 have met with resolution at the local level, they can appeal their grievances to the regional Department of Education, Office for Civil Rights.

Office for Civil Rights

8930 Ward Parkway, Suite 2037

Kansas City, MO 64114

816-268-0550

FAX: 816-823-1404; TDD: 800-437-

0833

If you have any questions regarding the contents of this handbook, please contact Madison Elementary School at 454-2656. We strive for each child to have a productive and rewarding school year!

Karla Kush

Elementary Principal

Madison Public Schools

P.O. Box 450

405 East 8th Street

Madison, NE 68748

402-454-2656 (Main Office)

kkush@esu8.org

Please read and discuss the contents of the Madison Elementary Parent-Student Policy Handbook with your child. By signing below, you are indicating that you have reviewed and understand the information and policies stated in the handbook and that the information has been discussed with your child(ren). I have received and read the Student Handbook that describes the Madison Public School District's discipline policies, regulations, rules, and expectations to be followed by students enrolled in the Madison Public Schools, including the Drug Free School Policy. This form also authorizes the school district to use your child's picture or likeness in the yearbook, school paper, website, and any other form of media the school district deems appropriate. This form authorizes the school district to take your student off campus for educational activities, sports activities, or any other sponsored trip that is deemed appropriate by the school district. My child and I have discussed these policies and understand that we must comply with them.

Parent/Guardian Signature

Date

Printed Student Name

Grade

PARENT/GUARDIAN NAME(S) _____

HOME ADDRESS _____

PHONE NUMBER 1 _____

PHONE NUMBER 2 _____

EMERGENCY CONTACT _____

Little Dragons Child Care

Mission Statement

Our mission is to provide a safe, caring, and stimulating environment for your children while giving parents peace of mind. We aim to provide an educational experience that promotes social, emotional, physical, and cognitive development.



405 E. 8th Street
Madison, NE 68748
402-454-2656
Madison Public Schools
402-454-3336

Parent(s) must have all paperwork handed in on or before the date your child(ren) begin childcare. These forms include:

1. Handbook/Contract Form
2. Enrollment/Infant Forms
3. Permission Slip Form
4. Current Copy of Immunization Records

Items to bring to daycare:

1. Extra set of weather appropriate clothing
2. Blanket to be kept at daycare (blanket needs to go home at the end of every week to be washed)
3. Diapers, wipes, and diaper cream, if needed

Please put your child's name on all items you bring to daycare!

These forms are to be kept current at all times. Any additions or changes in the information must be reported to Little Dragons staff. Parent(s) may look at their documentation at any time. Parent(s), staff, the school nurse and the state inspector will be the only people to verify your child(ren)s records. All records will be kept confidential.

RATES

Full-time/All Day

\$29.00 per day for 1st child • \$20.00 per day for any additional child

Part-time/Half Day (for preschool students only)

\$14.50/half-day for 1st child • \$10.00/half-day for any additional child

Sliding-Fee Scale

Income-eligible families may qualify for a reduced rate. In order to qualify, parents must fill out a Free/Reduced Lunch application.

Reduced-price lunches would pay a reduced rate of \$15.00 per day for the 1st child and \$12.00 per day for any child after that. (Half-days pay half the full day rate)

Families that qualify for FREE lunches would pay \$10.00 per day for the 1st child and \$8.00 per day for each additional child. (Half days pay half the full day rate)

Contracts

Little Dragons Child Care uses contracts to guarantee that there is a space for your child(ren). You will be responsible for filling out the paperwork to indicate the days you need care for your children. You are responsible for paying for your contracted days. Please refer to your contract for the dates of *the current school year*.

Contract for Madison Public Substitute Teachers

Local substitute teachers working for Madison Public Schools may utilize the Little Dragons Child Care services for their children, provided space is available. The fee for childcare services is at a fixed rate of \$2.50 per hour for the full day hours 7:00 a.m.-5:00 p.m. (You will be charged for the entire day you are contracted to sub.) Daycare availability will be determined at the time the substitute teaching assignment is agreed upon. **A substitute teaching assignment does not imply that there is childcare availability.**

Ratio

We are licensed to have a total of 8 children with two staff members present. As NDE's Rule 11 states, "A paraeducator or additional certified teacher will be assigned to assure a ratio of at least one (1) adult for each four (4) children with a maximum group size of eight (8)."

Schedule/Hours of Operation

Little Dragons Child Care Classroom will be open from 7:00 a.m. to 5:00 p.m. Monday through Friday.

We will follow the same schedule as Madison Public Schools, so when there are scheduled breaks, Little Dragons Child Care will not be open. For example, when Madison Public is closed for Winter Break over Christmas, the Child Care classroom will not be open. You will not be responsible for payment on the days that the childcare is closed. **Little Dragons Child Care Classroom will still be open regular hours on Teacher In-service Days and Teacher Workdays, unless otherwise noted and determined by the board or administration.**

Please pay attention to the weather. When school dismisses early due to severe weather, Little Dragons Child Care Classroom will also dismiss early. Little Dragons Child Care Classroom will be closed if Madison Public Schools chooses to close due to severe weather.

Absences

Parents are required to notify the childcare as soon as they know their child(ren) will not be attending. You will still be required to pay your contracted time regardless if your child attends.

Termination/Change in Contract

We require two weeks notice if you plan to terminate or change your contract. This is so that we can find a replacement for your spot. **IF YOU DO NOT GIVE NOTICE, YOU WILL BE CHARGED FOR THOSE TWO WEEKS.**

LATE CHARGES/OVERTIME

PICKUP WILL BE AT THE CLOSE OF BUSINESS FOR THE DAY. When we have an early dismissal, you are to pick up your children at 5:00pm unless otherwise communicated.

NEW FAMILIES

To reserve your spot for daycare, you will be required to pay a \$125.00 deposit per family. This deposit will be applied to your last two weeks of daycare at the end of the contracted year.

Illness Policy

All children and staff working with children are more often exposed to communicable diseases. We will make every attempt to exclude any sick children while he/she is contagious. Children will not be able to attend daycare if any of the following conditions exist:

- Elevated temperature: 100 degrees F. (**must be below 100 degrees without Tylenol or Ibuprofen for 24 hours**)
- Thick, foul smelling, bloody, or (PUS) drainage from wounds, nose, eyes, or ears.
- Vomiting in the last 24 hours
- Two or more cases of diarrhea, watery stools, or blood in stools within the past 24 hours. (Must be 24 hours since last episode)
- Persistent pain, including earaches, stomach pains, pain when urinating or injured limbs
- Sore throat or deep constant cough without a note from the doctor stating it is okay for him/her to return to daycare
- Runny or crusty eyes (matted and/or pink eyes are not acceptable)
 - If pink eye, child must have had antibiotic drops for 24 hours before returning to daycare.
- If a child has infectious condition. A note from the doctor stating that it is okay for the child to return to daycare such as:
 - Communicable diseases, including: chicken pox, influenza, strep throat, RSV, Hand-Foot-Mouth disease, measles, mumps, Coronavirus etc.
 - Skin conditions and rashes that itch or that are blistered. (must be treated at least 24 hours)
 - Scabies or ringworm
 - Parasite infections such as lice, or pinworms, until after proper treatment is given

Medication Policy

Staff can administer prescription medication that has been prescribed by a physician for said particular child and those medications must be in the original containers with child's name and instructions from a health professional. Over the counter medicine may be administered by staff under certain conditions, but never for reduction of fever, and medications must also be in original packaging and labeled. All medications to be giving during childcare hours must have signed consent by parent to administer, and this consent is to be renewed weekly. **Medication must be stored in a locked box while it is at daycare, please do not leave it in your child's cubby.**

If your child requires routine medications, it will be the parent's responsibility to schedule and administer the medication to the child.

Meals/Snacks

WE RECEIVE OUR BREAKFAST FROM MADISON PUBLIC SCHOOLS. The cost for breakfast is \$1.80 per day through the school. **If your child(ren) arrives after 8:30 a.m., they are expected to have already eaten.** We will have a small morning snack at 10:00. We will have a family style lunch served from 11:30-12:00. **DURING THE SCHOOL YEAR, WE RECEIVE OUR LUNCHESES FROM MADISON PUBLIC SCHOOLS.** The cost for lunch is \$2.95 per day through the school. **On the days where there is no school or lunch provided, such as In-Service days, PARENTS WILL BE ASKED TO BRING A SACK LUNCH FOR THEIR CHILD.** We will have an afternoon snack from 2:30-3:15, as children wake up from their nap.

Children will get a well-balanced, healthy diet with all the proper food groups. **If your child(ren) requires a special diet, parents will be required to provide their meals/snacks.** A lunch calendar is available upon request.

If you would like to apply for Free or Reduced Lunches, please contact Madison Public Schools for an application.

Infant/Toddler Policies

Feeding schedules are different for infants and younger children. Little Dragons Child Care is very supportive of breastfeeding mothers. We offer a nice, quiet, private area for you to breastfeed your child. You are welcome to stop in and breastfeed your child, if you prefer. Childcare providers are required to follow specific guidelines when working with breast milk, since it is a bodily fluid. **Breast milk must be labeled with the child's name and three dates: date pumped, date frozen, and date brought to daycare.**

If you use formula, you will be responsible for providing the formula for your child. Daycare staff will let you know when it is running low and you need to bring more. **Also, parents will be asked to provide baby food and cereal when needed, until the infant can eat regular food.**

Only disposable diapers will be used. Parents are responsible for bringing their own diapers, wipes, and diaper ointment, as needed. Daycare staff will notify you when you need to bring more.

Staff and parents will work together when the parent(s) think the child is ready to begin toilet training. Working as a team is key to success and we will discuss the process that you feel is the best for your child(ren).

Celebrations/Holidays

We will celebrate holidays at Little Dragons Child Care, including: Halloween, Thanksgiving, Christmas, Valentine's Day, St. Patrick's Day, Easter, etc. We will also recognize and celebrate your child(ren)s birthdays. You may bring treats for your children to share with the entire group, if you wish.

Discipline

When conflicts arise among children at childcare, children will be asked to "use their words" to explain their thoughts and feelings. Teachers and staff work with the children to teach children how to get along with each other and solve conflicts in a non-aggressive manner. Children exhibiting unacceptable behavior will be removed from the group, talked with about verbalizing their feelings, and brought back to the group when they are ready to make good choices and get along.

Childcare will use “think time” when needed. There is a designated spot in the daycare where children will go to calm down. They will sit for one minute for every year old they are (3 minutes for 3 years old).

If a child is having a tantrum or engaging in behavior that staff feels is a danger to themselves or others, or if they are interfering with staff’s ability to care for the other children, administration will be called and parents will be notified. **If more severe issues arise, we will have a meeting with parents and school administration to decide on a further plan of action.**

Staff will always inform you of any behavioral issues so we can form a plan of action together and maintain consistency from home to daycare.

Damages to Daycare Property

If your child intentionally breaks an item while at daycare (i.e. TV, iPad, baby gate, toy, etc.) PARENTS will be asked to pay to replace it. Your child is expected to treat daycare property with as much respect as they would items in their own home.

Community/School Partnerships

Little Dragons Child Care will be working with Madison Public Schools Preschool and Madison Public Schools throughout the year. We will have access to the preschool playground and the school gym (when not in use). We may also participate in activities throughout the year, which may include having students come to the daycare to read to your child(ren) or going to the school to do the same. Volunteers may stop by to share pets or other fun activities with us, too. Please notify us if your child has any animal or environmental allergies.

Safety Drills

All childcare students and staff will participate in school wide safety drills. Prior to any safety drills, students will be instructed in the procedures that will need to be followed. Typical safety drills will include fire drills, tornado drills, bus/van evacuation, school evaluation, lock downs, lock out and reunification.

Miscellaneous Information

- ◆ When communicating with the staff during business hours, please call Madison Elementary School at 402-454-2656 or Madison Public Schools (402) 454-3336. If there is no answer right away, please leave a message and someone will return your call ASAP.
- ◆ If you have a change in your contracted hours before or after business hours, please call the school at 402-454-2656 or the daycare to leave a message if there is no answer.
- ◆ **A major reason for Little Dragons Child Care is to provide childcare for Madison Public Schools teachers and staff, therefore, Madison Public Schools teachers and staff take precedence when providing care for their children. Spots are given to teachers and staff first and then filled with patrons outside of the school on a first-come, first-serve basis. Full-time spots also take precedence over part-time needs.**
- ◆ As a new business, rules are subject to change as the school board sees fit. If you have any questions or concerns, please contact childcare teacher or Mrs. Kush.



Houghton Mifflin Harcourt

Proposal

Prepared For

Madison Public School Dist 1

Attention:

Travis Jordan

tjordan@esu8.org

For the Purchase of:

Into Literature 2020 6-8 3 year subscription

Prepared By

Deborah Queen

deborah.queen@hmc.com

Please submit this proposal with your purchase order.

Purchase orders or duly executed service agreements for **Professional Services** purchased, must be submitted at least 30 days before the service event date.



Houghton Mifflin Harcourt

Attention:
Travis Jordan
tjordan@esu8.org

Customer Experience
9400 South Park Center Loop
Orlando, FL 32819
FAX: 800-269-5232
k12orders@hmc.com

HMH Confidential and Proprietary

Madison Public School Dist 1 Into Literature 2020 6-8 3 year subscription

ISBN	Title	Price	Quantity	Value of All Material	Free Materials Quantity
Grade 6					
Student Print & Digital Licenses					
9780358400905	Into Literature Student License Print/Digital 3 Year Grade 6 Includes: Student Edition Softcover 3 Year Print Grade 6 Digital Student Resources 3 Year Grades 6-8 Implementation Success	\$81.00	45	\$3,645.00	
Total for Student Print & Digital Licenses		\$3,645.00			
Teacher Digital Licenses					
9780358405726	Into Literature Digital Teacher Resources 3 Year Grades 6-8	\$270.00			1
Total for Teacher Digital Licenses		\$0.00			
A la Carte Items Available for Purchase					
Teacher Materials					
9781328474841	2020 Into Literature Teacher's Edition Grade 6	\$84.48	1	\$84.48	
Student Material					
9780358436041	Language Arts Novel 3 Points Recommended for a range of titles and choices from the HMH Novel List.	\$8.46	90	\$761.40	
9780358275442	Into Literature Grammar Practice Workbook Print Subscription 3 Year Grade 6	\$22.50	45	\$1,012.50	
Total for A la Carte Items Available for Purchase		\$1,858.38			
Total for Grade 6		\$5,503.38			



Attention:
Travis Jordan
tjordan@esu8.org

Customer Experience
9400 South Park Center Loop
Orlando, FL 32819
FAX: 800-269-5232
k12orders@hmc.com

HMH Confidential and Proprietary

Madison Public School Dist 1 Into Literature 2020 6-8 3 year subscription

ISBN	Title	Price	Quantity	Value of All Material	Free Materials Quantity
Grade 7					
Student Print & Digital Licenses					
9780358400936	Into Literature Student License Print/Digital 3 Year Grade 7 Includes: Student Edition Softcover 3 Year Print Grade 7 Digital Student Resources 3 Year Grades 6-8 Implementation Success	\$81.00	45	\$3,645.00	
Total for Student Print & Digital Licenses		\$3,645.00			
Teacher Digital Licenses					
9780358405726	Into Literature Digital Teacher Resources 3 Year Grades 6-8	\$270.00			1
Total for Teacher Digital Licenses		\$0.00			
A la Carte Items Available for Purchase					
Teacher Materials					
9781328474858	2020 Into Literature Teacher's Edition Grade 7	\$84.48	1	\$84.48	
Student Materials					
9780358436041	Language Arts Novel 3 Points Recommended for a range of titles and choices from the HMH Novel List.	\$8.46	90	\$761.40	
9780358275459	Into Literature Grammar Practice Workbook Print Subscription 3 Year Grade 7	\$22.50	45	\$1,012.50	
Total for A la Carte Items Available for Purchase		\$1,858.38			
Total for Grade 7		\$5,503.38			



Attention:
Travis Jordan
tjordan@esu8.org

Customer Experience
9400 South Park Center Loop
Orlando, FL 32819
FAX: 800-269-5232
k12orders@hmc.com

HMH Confidential and Proprietary

Madison Public School Dist 1 Into Literature 2020 6-8 3 year subscription

ISBN	Title	Price	Quantity	Value of All Material	Free Materials Quantity
Grade 8					
Student Print & Digital Licenses					
9780358400967	Into Literature Student License Print/Digital 3 Year Grade 8 Includes: Student Edition Softcover 3 Year Print Grade 8 Digital Student Resources 3 Year Grades 6-8 Implementation Success	\$81.00	45	\$3,645.00	
Total for Student Print & Digital Licenses		\$3,645.00			
Teacher Digital Licenses					
9780358405726	Into Literature Digital Teacher Resources 3 Year Grades 6-8	\$270.00			1
Total for Teacher Digital Licenses		\$0.00			
A la Carte Items Available for Purchase					
Teacher Materials					
9781328474865	2020 Into Literature Teacher's Edition Grade 8	\$84.48	1	\$84.48	
Student Materials					
9780358436041	Language Arts Novel 3 Points Recommended for a range of titles and choices from the HMH Novel List.	\$8.46	90	\$761.40	
9780358275466	Into Literature Grammar Practice Workbook Print Subscription 3 Year Grade 8	\$22.50	45	\$1,012.50	
Total for A la Carte Items Available for Purchase		\$1,858.38			
Total for Grade 8		\$5,503.38			



Attention:
Travis Jordan
tjordan@esu8.org

Customer Experience
9400 South Park Center Loop
Orlando, FL 32819
FAX: 800-269-5232
k12orders@hmc.com

HMH Confidential and Proprietary

Madison Public School Dist 1 Into Literature 2020 6-8 3 year subscription

ISBN	Title	Price	Quantity	Value of All Material	Free Materials Quantity
<u>Waggle ELA Non CCSS</u>					
Student Subscription Package					
9780358247272	2018 Waggle ELA Practice License includes Skill Boosts Non CCSS 3 Year Grades 2-8	\$26.99	135	\$3,643.65	
Total for Student Subscription Package		\$3,643.65			
Teacher					
9780358260783	Waggle ELA Teacher License 3 Year Grades 2-8	\$40.48			3
Total for Teacher		\$0.00			
<u>Total for Waggle ELA Non CCSS</u>		\$3,643.65			



Attention:
Travis Jordan
tjordan@esu8.org

Customer Experience
9400 South Park Center Loop
Orlando, FL 32819
FAX: 800-269-5232
k12orders@hmc.com

HMH Confidential and Proprietary

Madison Public School Dist 1 Into Literature 2020 6-8 3 year subscription

ISBN	Title	Price	Quantity	Value of All Material	Free Materials Quantity
<u>Professional Services</u>					
Year 1 Implementation Success Plan					
9781328594198	Into Literature Follow Up 1 Hour Webinar Session Grade 6-12 Work with an HMH Services team member to choose from key Into Literature instructional topics to create a personalized Follow-Up live online session. Includes one, 1-hour live online session.		1		
Year 2 Implementation Success Plan					
9781328594198	Into Literature Follow Up 1 Hour Webinar Session Grade 6-12 Work with an HMH Services team member to choose from key Into Literature instructional topics to create a personalized Follow-Up live online session. Includes one, 1-hour live online session.		1		
Coaching					
Grade 9-12					
9781328594235	Into Literature Team Coaching Grade 6-8 Team Coaching brings the coaching conversation into a small group context and opens up communication among teachers. It is a collaborative conversation, focused on deepening understanding of student work, student learning targets, instructional practices, goal setting, and action steps.	\$2,800.00	4	\$11,200.00	
Total for Coaching		\$11,200.00			
Getting Started with Into Literature					
9781328594129	Into Literature Getting Started Full Day Grade 6-12 Participants engage in a variety of hands-on experiences to learn about the organization, design, and resources of Into Literature. Through direct instruction, guided practice, and cooperative exploration, participants will experience the program's resources both from a student and teacher perspective. The goal is to build deeper understanding and confidence to begin implementing Into Literature in their respective learning environments.	\$2,800.00	1	\$2,800.00	
Total for Getting Started with Into Literature		\$2,800.00			
<u>Total for Professional Services</u>		\$14,000.00			



Attention:
Travis Jordan
tjordan@esu8.org

Customer Experience
9400 South Park Center Loop
Orlando, FL 32819
FAX: 800-269-5232
k12orders@hnhco.com

HMH Confidential and Proprietary

Madison Public School Dist 1 Into Literature 2020 6-8 3 year subscription

ISBN	Title	Price	Quantity	Value of All Material	Free Materials Quantity
<u>Professional Services</u>					
Foundational Professional Learning					
9780358242451	2018 Waggle ELA Getting Started 2-Hour Webinar Grade 2-8 Participants will learn the hows and whys of Waggle! Through direct instruction, participants will learn the driving philosophy behind Waggle - an engaging, productive practice environment for all learners that unifies content and empowers teachers- while also gaining an understanding of the real-world application of the program. The goal is to build deeper understanding and confidence to begin implementing Waggle in their respective learning environments.	\$800.00	1	\$800.00	
Total for Foundational Professional Learning		\$800.00			
<u>Total for Professional Services</u>		\$800.00			



Houghton Mifflin Harcourt

Attention:
Travis Jordan
tjordan@esu8.org

Customer Experience
9400 South Park Center Loop
Orlando, FL 32819
FAX: 800-269-5232
k12orders@hmc.com

HMH Confidential and Proprietary

Proposal for
Madison Public School Dist 1
Into Literature 2020 6-8 3 year subscription

ISBN	Title	Price	Quantity	Value of All Material	Free Materials Quantity
------	-------	-------	----------	-----------------------	-------------------------

<i>Subtotal Purchase Amount:</i>	\$34,953.79
<i>Shipping & Handling:</i>	\$1,209.20
<i>Sales Tax:</i>	\$0.00
Total Cost of Proposal (PO Amount):	\$36,162.99



Houghton Mifflin Harcourt

Attention:
Travis Jordan
tjordan@esu8.org

Customer Experience
9400 South Park Center Loop
Orlando, FL 32819
FAX: 800-269-5232
k12orders@hnhco.com

HMH Confidential and Proprietary

Total Cost of Proposal (PO Amount): \$36,162.99

Thank you for considering HMH as your partner. We are committed to providing an excellent experience and delivering ongoing, high-quality service to our customers. To meet these goals, we want to ensure you are aware of the below Terms of Purchase. These terms help us process your order quickly, efficiently, and accurately, ensuring successful delivery and implementation of our solutions.

- Please return this cost proposal with your signed purchase order that matches product, prices and shipping charges.
- Provide the exact address for *delivery* of print materials. The shipping address may be your district warehouse or individual school sites, but it is essential that this is accurate.
- Please supply the name of each important district point of contact for all aspects of the solution including their direct contact information (email/phone):
 - o Point of Contact for Print materials
 - o Point of Contact for Digital materials
 - o Point of Contact for Scheduling Professional Development
- Please confirm that we have the correct 'Ship to' and 'Sold to' information on the cost proposal.

<p>Ship to: Madison Public School District 1</p> <p>Madison, NE 68748-0450</p>	<p>Sold to: Madison Public School District 1</p> <p>Madison, NE 68748-0450</p>
---	---
- Please provide funding start and end dates.
- Please note that all products and services will be billed upon the processing of your purchase order.
- Our payment terms are 30 days from the invoice date.
- Print subscription material quantities may be adjusted across grades for like products, to accommodate enrollment fluctuations, quantities cannot be adjusted between different programs or copyrights.
- Our shipping terms are FOB shipping point. The shipping term for your proposal is Shipping Point.
- Should any of these Terms of Sale conflict with any preprinted terms on your purchase order, the HMH terms of service shall apply.

Thank you in advance for supplying us with the necessary information at time of purchase.

Our goal is to ensure your success throughout the duration of this agreement, which starts with a highly successful delivery of our solution.

For greater detail, the complete Terms of Purchase may be reviewed here: <http://www.hmhco.com/common/terms-conditions>

Date of Proposal: 2/20/2020

Proposal Expiration Date: 4/5/2020



Houghton Mifflin Harcourt



Houghton Mifflin Harcourt

Attention:
Travis Jordan
tjordan@esu8.org

Customer Experience
9400 South Park Center Loop
Orlando, FL 32819
FAX: 800-269-5232
k12orders@hnhco.com

HMH Confidential and Proprietary

Apple Inc. Education Price Quote

Customer:	Trish Braithwait MADISON PUBLIC SCHOOL SCHOOL DISTRICT NO 1 Phone: 4026405680 email: tbraithwait@me.com	Apple Inc:	Ryan Meyer One Apple Park Way Cupertino, CA 95014 email: meyer@apple.com
------------------	---	-------------------	---

Apple Quote: 2206243140

Quote Date: Wednesday, April 29, 2020

Quote Valid Until: Wednesday, May 27, 2020

Quote Comments:

Please reference Apple Quote number on your Purchase Order.

#	Product Description	Qty	Unit List Price	Discount per Unit	Unit Discounted Price	Extended Discounted Price
1	13-inch MacBook Pro with Touch Bar: 1.4GHz quad-core 8th-generation Intel Core i5 processor, 128GB – Space Gray (5-Pack) Part Number MVUV2LL/A Configuration: <ul style="list-style-type: none"> • 065-C7C1 1.4GHz quad-core 8th-generation Intel Core i5 processor, Turbo Boost up to 3.9GHz • 065-C7C3 Intel Iris Plus Graphics 645 • 065-C7C4 8GB 2133MHz LPDDR3 memory • 065-C7C6 128GB SSD storage • 065-C7CD Force Touch Trackpad • 065-C7CF Two Thunderbolt 3 Ports • 065-C8KJ Touch Bar and Touch ID • 065-C7D3 Backlit Keyboard – US English 	5	\$1,179.00	\$30.00	\$1,149.00	\$5,745.00
2	16-inch MacBook Pro with Touch Bar: 2.6GHz 6-core 9th-generation Intel Core i7 processor, 512GB – Space Gray Part Number MVVJ2LL/A Configuration: <ul style="list-style-type: none"> • 065-C879 2.6GHz 6-core Intel Core i7, Turbo Boost up to 4.5GHz • 065-C87F AMD Radeon Pro 5300M with 4GB of GDDR6 memory • 065-C87J 16GB 2666MHz DDR4 memory • 065-C87M 512GB SSD storage 	1	\$2,199.00	\$100.00	\$2,099.00	\$2,099.00

- 065-C87V Retina display with True Tone
- 065-C87W Four Thunderbolt 3 ports
- 065-C87X Touch Bar and Touch ID
- 065-C8F6 Backlit Keyboard – US English

3	27-inch iMac with Retina 5K display: 3.0GHz 6-core 8th-generation Intel Core i5 processor, 1TB	4	\$1,699.00	\$70.00	\$1,629.00	\$6,516.00
	Part Number MRQY2LL/A					
	Configuration:					
	<ul style="list-style-type: none"> • 065-C7GL 3.0GHz 6-core 8th-generation Intel Core i5 processor, Turbo Boost up to 4.1GHz • 065-C6WK 8GB 2666MHz DDR4 memory • 065-C6WP 1TB Fusion Drive storage • 065-C7GX Radeon Pro 570X with 4GB GDDR5 memory • 065-C6XC Apple Magic Mouse 2 • 065-C6XH Magic Keyboard – US English 					
4	USB-C Digital AV Multiport Adapter	6	\$69.00	\$0.00	\$69.00	\$414.00
	Part Number MUF82AM/A					

Extended EDU List Price Total	\$15,304.00
Total Discount	\$530.00
Extended Discounted Price Subtotal	\$14,774.00
- Additional Tax	\$0.00
- Estimated Tax	\$0.00
Extended Discounted Total Price*	\$14,774.00

*In most cases Extended discounted Total price does not include Sales Tax

*If applicable, eWaste/Recycling Fees are included. Standard shipping is complimentary

Complete your order by one of the following:

- This document has been created for you as Apple Quote ID 2206243140. Please contact your institution's Authorized Purchaser to submit the above quote online. For account access or new account registration, go to <https://ecommerce.apple.com>. Simply go to the Quote area of your Apple Education Online Store, click on it and convert to an order.
 - For registration assistance, call 1.800.800.2775
- If you are unable to submit your order online, please send a copy of this Quote with your Purchase Order via email to institutionorders@apple.com. **Be sure to reference the Apple Quote number on the PO to ensure expedited processing of your order.**
 - For more information, go to provision C below, for details.

THIS IS A QUOTE FOR THE SALE OF PRODUCTS OR SERVICES. YOUR USE OF THIS QUOTE IS SUBJECT TO THE FOLLOWING PROVISIONS WHICH CAN CHANGE ON SUBSEQUENT QUOTES:

- A. ANY ORDER THAT YOU PLACE IN RESPONSE TO THIS QUOTE WILL BE GOVERNED BY (1) ANY CONTRACT IN EFFECT BETWEEN APPLE INC. ("APPLE") AND YOU AT THE TIME YOU PLACE THE ORDER OR (2), IF YOU DO NOT HAVE A CONTRACT IN EFFECT WITH APPLE, CONTACT contracts@apple.com.

- B. B. ALL SALES ARE FINAL. PLEASE REVIEW RETURN POLICY BELOW IF YOU HAVE ANY QUESTIONS. IF YOU USE YOUR INSTITUTION'S PURCHASE ORDER FORM TO PLACE AN ORDER IN RESPONSE TO THIS QUOTE, APPLE REJECTS ANY TERMS SET OUT ON THE PURCHASE ORDER THAT ARE INCONSISTENT WITH OR IN ADDITION TO THE TERMS OF YOUR AGREEMENT WITH APPLE.
- C. C. YOUR ORDER MUST REFER SPECIFICALLY TO THIS QUOTE AND IS SUBJECT TO APPLE'S ACCEPTANCE. ALL FORMAL PURCHASE ORDERS SUBMITTED BY EMAIL MUST SHOW THE INFORMATION BELOW:
- o APPLE INC. AS THE VENDOR
 - o BILL-TO NAME AND ADDRESS FOR YOUR APPLE ACCOUNT
 - o PHYSICAL SHIP-TO NAME AND ADDRESS (NO PO BOXES)
 - o PURCHASE ORDER NUMBER
 - o VALID SIGNATURE OF AN AUTHORIZED PURCHASER
 - o APPLE PART NUMBER AND/OR DESCRIPTION OF PRODUCT AND QUANTITY
 - o TOTAL DOLLAR AMOUNT AUTHORIZED OR UNIT PRICE AND EXTENDED PRICE ON ALL LINE ITEMS
 - o CONTACT INFORMATION: NAME, PHONE NUMBER AND EMAIL
- D. UNLESS THIS QUOTE SPECIFIES OTHERWISE, IT REMAINS IN EFFECT UNTIL {QuoteExpirationDate} UNLESS APPLE WITHDRAWS IT BEFORE YOU PLACE AN ORDER, BY SENDING NOTICE OF ITS INTENTION TO WITHDRAW THE QUOTE TO YOUR ADDRESS SET OUT IN THE QUOTE.
- o APPLE MAY MODIFY OR CANCEL ANY PROVISION OF THIS QUOTE, OR CANCEL ANY ORDER YOU PLACE PURSUANT TO THIS QUOTE, IF IT CONTAINS A TYPOGRAPHIC OR OTHER ERROR.
- E. THE AMOUNT OF THE VOLUME PURCHASE PROGRAM (VPP) CREDIT SHOWN ON THIS QUOTE WILL ALWAYS BE AT UNIT LIST PRICE VALUE DURING REDEMPTION ON THE VPP STORE.
- F. UNLESS SPECIFIED ABOVE, APPLE'S STANDARD SHIPPING IS INCLUDED IN THE TOTAL PRICE.

SEA # 2017602
Opportunity ID:
<https://ecommerce.apple.com>
Fax:

[Terms & Use](#) | [Privacy Policy](#) | [Return Policy](#)
Copyright © 2016 Apple Inc. All rights reserved.

Document rev 10.6.1

Date of last revision – June 20th, 2016



Highway 65 South, Conway, AR 72032 - orders@virco.com
2027 Harpers Way, Torrance, CA 90501 - orders@virco.com

Equipment for Educators™

QUOTATION #8223833
r.3

Sold To:
MADISON PUBLIC SCHOOL DISTRICT 1
700 SOUTH KENT
MADISON NE 68748

Ship To:
MADISON MIDDLE SR HIGH SCHOOL
700 S KENT ST
MADISON NE 68748
REFERENCE: 02.19.2020 | COMMONS
AREA

Quotation Date: 5/7/2020

We appreciate the opportunity to quote the enclosed prices for our products. Unless otherwise indicated, prices are net and do not include sales tax. Please refer to the above referenced Quotation Number when corresponding with Virco regarding this quote. We offer our quotation priced from the US COMMUNITIES 2020 CONTRACT #R-TC-18004 CLASSROOM FURNITURE Contract. You will need to be registered for US Communities and provide your TIN number prior to acceptance of your purchase order. We offer our quotation subject to the following terms and conditions:

- 1) FOB Point: FOB Destination - Tailgate Delivery
- 2) Payment Terms: Net 30 days (subject to credit approval)
- 3) Prices Are Firm: For Orders Received By 12/31/2020 *(Promo Prices Expire 12/31/2020)*
Orders received after this date are subject to re-Quote.
- 4) For Shipment By: Customer Must Take Delivery Before 12/31/2020
- 5) Shipment from Virco: PLEASE NOTE: Quick Ship Items are in stock and ready to ship quickly, usually in 5 business days. Classroom Basics models are assembled upon receipt of an order from components we stock and are usually ready to ship in 4 weeks except for July and August when lead-times may be extended. Models not included in Quick Ship or Classroom Basics are Made-to-Order and are usually ready within 6-8 weeks except for July and August when lead-times may be extended. Custom products or specials: Extended lead times may apply, contact your Sales Representative for more information. If products with different leadtimes are on the same purchase order, the longest leadtime will apply to the entire order. Additional shipping and handling charges will apply to orders that are requested to be partial shipped before the Virco acknowledged due date. Orders that specify shipment later than the preceding dates will be subject to re-quote
- 6) Color: Standard Virco colors only unless specified otherwise
- 7) Purchase Order: We require customer approval by purchase order or signed quote to be emailed to Orders@virco.com or faxed to (800) 258-7367 or (800) 396-8232



Highway 65 South, Conway, AR 72032 - orders@virco.com
2027 Harpers Way, Torrance, CA 90501 - orders@virco.com

Equipment for Educators™

QUOTATION #8223833
r.3

- 8) Acknowledgement: Final acceptance and acknowledgement of orders will be as stated on the standard Virco Purchase Order Acknowledgment
- 9) Quantity: Any change in quantities may result in a price change



Equipment for Educators™

QUOTATION #8223833
r.3

Shipping To: MADISON MIDDLE SR HIGH SCHOOL

Item #	Supplier/Model #	Description	Unit Price	Qty	Extension
1	Virco Inc #MTSE17291012AE	Mobile Table, Stool Table Series, 17 High Stools, 29 H X 119 1/2 X 45 Eclipse, 12 Stools, High-Pressure Laminate MDF Top With Sure Edge, Up- And Down-Lock Mechanisms, Torsion Bars For Smooth Operation, Opening And Closing Safety Device - 4 ea Soft Plastic->Graphite (GRY41) Laminate->Grey Nebula (GRY091) Sure Edge->Red (RED70) Frame->Chrome (CHRM)	\$2,019.87	4	\$8,079.48
2	Virco Inc #U36RAE	Top For Table, Universal Tops Series, Cafe Top, 36 Round, 1-1/8 High Pressure Laminate MDF Top With Backing Sheet And Sure Edge - 4 ea Laminate->Grey Nebula (GRY091) Sure Edge->Red (RED70)	\$106.79	4	\$427.16
3	Virco Inc #6613341CHRM	Cafe Table Base, Lunada Series, X-Shaped, Tubular Steel Column With Die-Cast Aluminum Feet And 3" Diameter Abs Glides, 33" Base Spread, 41" Top Height. Accepts Virco Table Top Models C36r, C36sl, C36sq, C42r, C42sl, C42sq, U36r, U3636 And U42r. Chrome Frame And Graphite Color Glides Only. - 6 ea Base->Chrome (CHRM) Column->Chrome (CHRM) Glide Color->Graphite (GRY41)	\$271.11	6	\$1,626.66
4	Virco Inc #CA30ELFG	Stool, Civitas® Series, 4-Leg, 30" Seat Height, Ergonomically Contoured Extra Large Analogy® Polypropylene Shell, Steel Frame, Felt-Base Swivel Glides. - 16 ea Soft Plastic->Red (RED70) Frame->Chrome (CHRM)	\$77.88	16	\$1,246.08
5	Virco Inc #AN18FG	Chair, Analogy(tm) Series, 4-Leg, Stackable, 18" Seat Height, Ergonomically Contoured Polypropylene Shell, Steel Frame, Felt-Base Swivel Glides. Standard With Graphite Color Glide Sleeves On - 32 ea Soft Plastic->Graphite (GRY41) Frame->Chrome (CHRM)	\$59.62	32	\$1,907.84 Promo Price Exp. 12/31/2020
6	Virco Inc #U3048AE	Top For Table, Universal Tops Series, Cafe Top, 30 X 48 , 1-1/8 High Pressure Laminate MDF Top With Backing Sheet And Sure Edge - 8 ea Laminate->Grey Nebula (GRY091) Sure Edge->Red (RED70)	\$111.22	8	\$889.76
7	Virco Inc #66222CHRM	Cafe Table Base, Lunada Series, Bi-Point, Tubular Steel Column With Die-Cast Aluminum Feet And 3" Diameter Abs Glides, 22" Base Spread, 29" Top Height. Accepts Virco Table Top Models U2430, U3030, U3042 And U3048. Standard With Chrome Frame And Graphite Color Glides Only. - 16 ea Base->Chrome (CHRM) Column->Chrome (CHRM) Glide Color->Graphite (GRY41)	\$149.86	16	\$2,397.76
8	Virco Inc #U30RAE	Top For Table, Universal Tops Series, Cafe Top, 30 Round, 1-1/8 High Pressure Laminate MDF Top With Backing Sheet And Sure Edge - 2 ea Laminate->Grey Nebula (GRY091) Sure Edge->Red (RED70)	\$84.96	2	\$169.92
9	Virco Inc #MT60RAE	Mobile Table, Contourfold Series, No Seats, 60 Round High-Pressure Laminate MDF Top, Sure Edge® Edge Finish, Up- And Down-Lock Mechanisms, Torsion Bars For Smooth Operation, Opening And Closing Safety Device. - 2 ea Laminate->Grey Nebula (GRY091) Sure Edge->Red (RED70) Frame->Chrome (CHRM)	\$883.53	2	\$1,767.06
					\$18,511.72



Equipment for Educators™

QUOTATION #8223833
r.3

Shipping To: MADISON MIDDLE SR HIGH SCHOOL

Item #	Supplier/Model #	Description	Unit Price	Qty	Extension
--------	------------------	-------------	------------	-----	-----------

The undersigned certifies understanding and agreement of this Quote Letter and has authority to sign for purchase.

MADISON PUBLIC SCHOOL DISTRICT 1
700 SOUTH KENT
MADISON NE 68748

X _____
PO # (if available)

X _____
Name (Print)

X _____
Authorized Signature

If paying by credit card, please call 877-311-9157. The credit specialist will be pleased to assist with your payment.

How To Place Your Order With Virco

3 Ways To Order:

1. Email your PDF quote from Virco to orders@virco.com (please make sure the quote is signed before submitting)
2. Email your standard PO to orders@virco.com
3. Order online at Shop.Virco.com (must register with Inside Sales)

What to Expect Once Order Is Placed *(see below to complete the order process)*

- We will respond to let you know your order was received.
- Once we process your order, an electronic or paper acknowledgment will be sent

In Order to Complete the Order Process, Virco Must Receive The Following Information

Account Info

- "Sold To" Information
- "Ship To" Information
- Pricing source

Delivery Info

- Delivery contact information (name and phone number for a call before delivery)
- Special delivery requests such as specific delivery hours
- Requested delivery date if applicable (orders without requested delivery dates will be entered under ASAP priority and will be shipped as soon as product is ready)

****Please note - our system only allows 8 lines of 30 characters each so please make sure to prioritize any delivery info****

Product Info

- Model (Ex: 9018, ZBOOMMFG)

Color/Finish for the Following:

CHAIRS

- Bucket Color Frame Color Glide
(Ex: Navy/Chrome/Nylon Glides)

TABLES/DESKS

- Top/Edge Banding Frame Color Glide
(Ex: Dry Creek Plum/Adobe/Silver Mist/Felt Glides)





FILING CABINETS

- Frame Color
(Ex: Moonstone)







QUOTATION #8223833

r.3

Item #	Supplier/Model #	Description	
1	Virco Inc #MTSE172910-12AE	Mobile Table, Stool Table Series, 17 High Stools, 29 H X 119 1/2 X 45 Eclipse, 12 Stools, High-Pressure Laminate MDF Top With Sure Edge, Up- And Down-Lock Mechanisms, Torsion Bars For Smooth Operation, Opening And Closing Safety Device (Soft Plastic->Graphite (GRY41) Laminate->Grey Nebula (GRY091) Sure Edge->Red (RED70) Frame->Chrome (CHRM)) Qty: 4	 <p align="center">Image Does Not Reflect Actual Color Bid</p>
2	Virco Inc #U36RAE	Top For Table, Universal Tops Series, Cafe Top, 36 Round, 1-1/8 High Pressure Laminate MDF Top With Backing Sheet And Sure Edge (Laminate->Grey Nebula (GRY091) Sure Edge->Red (RED70)) Qty: 4	 <p align="center">Base Sold Separately</p> <p align="center">Image Does Not Reflect Actual Color Bid</p>
3	Virco Inc #6613341CHRM	Cafe Table Base, Lunada Series, X-Shaped, Tubular Steel Column With Die-Cast Aluminum Feet And 3" Diameter Abs Glides, 33" Base Spread, 41" Top Height. Accepts Virco Table Top Models C36r, C36sl, C36sq, C42r, C42sl, C42sq, U36r, U3636 And U42r. Chrome Frame And Graphite Color Glides Only. (Base-> Chrome (CHRM) Column->Chrome (CHRM) Glide Color->Graphite (GRY41)) Qty: 6	 <p align="center">Image Does Not Reflect Actual Color Bid</p>
4	Virco Inc #CA30ELFG	Stool, Civitas® Series, 4-Leg, 30" Seat Height, Ergonomically Contoured Extra Large Analogy® Polypropylene Shell, Steel Frame, Felt-Base Swivel Glides. (Soft Plastic->Red (RED70) Frame->Chrome (CHRM)) Qty: 16	

QUOTATION #8223833

r.3

Item #	Supplier/Model #	Description	
5	Virco Inc #AN18FG	Chair, Analogy(tm) Series, 4-Leg, Stackable, 18" Seat Height, Ergonomically Contoured Polypropylene Shell, Steel Frame, Felt-Base Swivel Glides. Standard With Graphite Color Glide Sleeves On (Soft Plastic->Graphite (GRY41) Frame->Chrome (CHRM)) Qty: 32	
6	Virco Inc #U3048AE	Top For Table, Universal Tops Series, Cafe Top, 30 X 48 , 1-1/8 High Pressure Laminate MDF Top With Backing Sheet And Sure Edge (Laminate->Grey Nebula (GRY091) Sure Edge->Red (RED70)) Qty: 8	
7	Virco Inc #66222CHRM	Cafe Table Base, Lunada Series, Bi-Point, Tubular Steel Column With Die-Cast Aluminum Feet And 3" Diameter Abs Glides, 22" Base Spread, 29" Top Height. Accepts Virco Table Top Models U2430, U3030, U3042 And U3048. Standard With Chrome Frame And Graphite Color Glides Only. (Base->Chrome (CHRM) Column->Chrome (CHRM) Glide Color->Graphite (GRY41)) Qty: 16	 <p align="center">IMAGE COMING SOON</p> <p align="center">Image Does Not Reflect Actual Color Bid</p>
8	Virco Inc #U30RAE	Top For Table, Universal Tops Series, Cafe Top, 30 Round, 1-1/8 High Pressure Laminate MDF Top With Backing Sheet And Sure Edge (Laminate->Grey Nebula (GRY091) Sure Edge->Red (RED70)) Qty: 2	 <p align="center">Base Sold Separately</p> <p align="center">Image Does Not Reflect Actual Color Bid</p>

QUOTATION #8223833

r.3

Item #	Supplier/Model #	Description	
9	Virco Inc #MT60RAE	Mobile Table, Contourfold Series, No Seats, 60 Round High-Pressure Laminate MDF Top, Sure Edge® Edge Finish, Up- And Down-Lock Mechanisms, Torsion Bars For Smooth Operation, Opening And Closing Safety Device. (Laminate->Grey Nebula (GRY091) Sure Edge->Red (RED70) Frame->Chrome (CHRM)) Qty: 2	 <p data-bbox="1096 567 1559 596">Image Does Not Reflect Actual Color Bid</p>



Highway 65 South, Conway, AR 72032 - orders@virco.com
2027 Harpers Way, Torrance, CA 90501 - orders@virco.com

Equipment for Educators™

QUOTATION #8227273
r.3

Sold To:
MADISON PUBLIC SCHOOL DISTRICT 1
700 SOUTH KENT
MADISON NE 68748

Ship To:
MADISON MIDDLE SR HIGH SCHOOL
700 S KENT ST
MADISON NE 68748
REFERENCE: CAFETERIA ALT

Quotation Date: 5/7/2020

We appreciate the opportunity to quote the enclosed prices for our products. Unless otherwise indicated, prices are net and do not include sales tax. Please refer to the above referenced Quotation Number when corresponding with Virco regarding this quote. We offer our quotation priced from the US COMMUNITIES 2020 CONTRACT #R-TC-18004 CLASSROOM FURNITURE Contract. You will need to be registered for US Communities and provide your TIN number prior to acceptance of your purchase order. We offer our quotation subject to the following terms and conditions:

- 1) FOB Point: FOB Destination - Tailgate Delivery
- 2) Payment Terms: Net 30 days (subject to credit approval)
- 3) Prices Are Firm: For Orders Received By 12/31/2020 Orders received after this date are subject to re-quote
- 4) For Shipment By: Customer Must Take Delivery Before 12/31/2020
- 5) Shipment from Virco: PLEASE NOTE: Quick Ship Items are in stock and ready to ship quickly, usually in 5 business days. Classroom Basics models are assembled upon receipt of an order from components we stock and are usually ready to ship in 4 weeks except for July and August when lead-times may be extended. Models not included in Quick Ship or Classroom Basics are Made-to-Order and are usually ready within 6-8 weeks except for July and August when lead-times may be extended. Custom products or specials: Extended lead times may apply, contact your Sales Representative for more information. If products with different leadtimes are on the same purchase order, the longest leadtime will apply to the entire order. Additional shipping and handling charges will apply to orders that are requested to be partial shipped before the Virco acknowledged due date. Orders that specify shipment later than the preceding dates will be subject to re-quote
- 6) Color: Standard Virco colors only unless specified otherwise
- 7) Purchase Order: We require customer approval by purchase order or signed quote to be emailed to Orders@virco.com or faxed to (800) 258-7367 or (800) 396-8232
- 8) Acknowledgement: Final acceptance and acknowledgement of orders will be as stated on the standard Virco Purchase Order Acknowledgment



Highway 65 South, Conway, AR 72032 - orders@virco.com
2027 Harpers Way, Torrance, CA 90501 - orders@virco.com

Equipment for Educators™

QUOTATION #8227273
r.3

9) Quantity: Any change in quantities may result in a price change



Equipment for Educators™

QUOTATION #8227273
r.3

Shipping To: MADISON MIDDLE SR HIGH SCHOOL

Item #	Supplier/Model #	Description	Unit Price	Qty	Extension
1	Virco Inc #MTSE17291012AE	Mobile Table, Stool Table Series, 17 High Stools, 29 H X 119 1/2 X 45 Eclipse, 12 Stools, High-Pressure Laminate MDF Top With Sure Edge, Up- And Down-Lock Mechanisms, Torsion Bars For Smooth Operation, Opening And Closing Safety Device - 6 ea Soft Plastic->Graphite (GRY41) Laminate->Grey Nebula (GRY091) Sure Edge->Red (RED70) Frame->Chrome (CHRM)	\$2,019.87	6	\$12,119.22
2	Virco Inc #6613341CHRM	Cafe Table Base, Lunada Series, X-Shaped, Tubular Steel Column With Die-Cast Aluminum Feet And 3" Diameter Abs Glides, 33" Base Spread, 41" Top Height. Accepts Virco Table Top Models C36r, C36sl, C36sq, C42r, C42sl, C42sq, U36r, U3636 And U42r. Chrome Frame And Graphite Color Glides Only. - 7 ea Base->Chrome (CHRM) Column->Chrome (CHRM) Glide Color->Graphite (GRY41)	\$271.11	7	\$1,897.77
3	Virco Inc #CZ30	Stool, Civitas Series, 4-Leg, 30" Seat Height, Ergonomically Contoured Zuma Plastic Seat, Steel Frame, Nylon-Base Swivel Glides. - 20 ea Soft Plastic->Red (RED70) Frame->Chrome (CHRM)	\$106.50	20	\$2,130.00
4	Virco Inc #U30RAE	Top For Table, Universal Tops Series, Cafe Top, 30 Round, 1-1/8 High Pressure Laminate MDF Top With Backing Sheet And Sure Edge - 2 ea Laminate->Grey Nebula (GRY091) Sure Edge->Red (RED70)	\$84.96	2	\$169.92
					\$16,316.91

The undersigned certifies understanding and agreement of this Quote Letter and has authority to sign for purchase.

MADISON PUBLIC SCHOOL DISTRICT 1
700 SOUTH KENT
MADISON NE 68748

X _____
PO # (if available)

X _____
Name (Print)

X _____
Authorized Signature

If paying by credit card, please call 877-311-9157. The credit specialist will be pleased to assist with your payment.

How To Place Your Order With Virco

3 Ways To Order:

1. Email your PDF quote from Virco to orders@virco.com (please make sure the quote is signed before submitting)
2. Email your standard PO to orders@virco.com
3. Order online at Shop.Virco.com (must register with Inside Sales)

What to Expect Once Order Is Placed *(see below to complete the order process)*

- We will respond to let you know your order was received.
- Once we process your order, an electronic or paper acknowledgment will be sent

In Order to Complete the Order Process, Virco Must Receive The Following Information

Account Info

- "Sold To" Information
- "Ship To" Information
- Pricing source

Delivery Info

- Delivery contact information (name and phone number for a call before delivery)
- Special delivery requests such as specific delivery hours
- Requested delivery date if applicable (orders without requested delivery dates will be entered under ASAP priority and will be shipped as soon as product is ready)

****Please note - our system only allows 8 lines of 30 characters each so please make sure to prioritize any delivery info****

Product Info

- Model (Ex: 9018, ZBOOMMFG)

Color/Finish for the Following:

CHAIRS

- Bucket Color Frame Color Glide
(Ex: Navy/Chrome/Nylon Glides)

TABLES/DESKS

- Top/Edge Banding Frame Color Glide
(Ex: Dry Creek Plum/Adobe/Silver Mist/Felt Glides)





FILING CABINETS

- Frame Color
(Ex: Moonstone)



QUOTATION #8227273

r.3

Item #	Supplier/Model #	Description	
1	Virco Inc #MTSE172910-12AE	Mobile Table, Stool Table Series, 17 High Stools, 29 H X 119 1/2 X 45 Eclipse, 12 Stools, High-Pressure Laminate MDF Top With Sure Edge, Up- And Down-Lock Mechanisms, Torsion Bars For Smooth Operation, Opening And Closing Safety Device (Soft Plastic->Graphite (GRY41) Laminate->Grey Nebula (GRY091) Sure Edge->Red (RED70) Frame->Chrome (CHRM)) Qty: 6	 <p align="right">Image Does Not Reflect Actual Color Bid</p>
2	Virco Inc #6613341CHRM	Cafe Table Base, Lunada Series, X-Shaped, Tubular Steel Column With Die-Cast Aluminum Feet And 3" Diameter Abs Glides, 33" Base Spread, 41" Top Height. Accepts Virco Table Top Models C36r, C36sl, C36sq, C42r, C42sl, C42sq, U36r, U3636 And U42r. Chrome Frame And Graphite Color Glides Only. (Base-> Chrome (CHRM) Column->Chrome (CHRM) Glide Color->Graphite (GRY41)) Qty: 7	 <p align="right">Image Does Not Reflect Actual Color Bid</p>
3	Virco Inc #CZ30	Stool, Civitas Series, 4-Leg, 30" Seat Height, Ergonomically Contoured Zuma Plastic Seat, Steel Frame, Nylon-Base Swivel Glides. (Soft Plastic->Red (RED70) Frame->Chrome (CHRM)) Qty: 20	
4	Virco Inc #U30RAE	Top For Table, Universal Tops Series, Cafe Top, 30 Round, 1-1/8 High Pressure Laminate MDF Top With Backing Sheet And Sure Edge (Laminate->Grey Nebula (GRY091) Sure Edge->Red (RED70)) Qty: 2	 <p align="center">Base Sold Separately</p> <p align="right">Image Does Not Reflect Actual Color Bid</p>



Shopping Cart

Item	Description	Stock #	Price	Quantity	Subtotal
	Mobile Stool Table w/ Elliptical Top Top: Gray Glace -G Stool Top: Red -R Stool Bottom: Black -BK Edge: Dyna Rock Red -DRR (\$120.00 per unit) Frame: Chrome -C (\$192.00 per unit) Plywood: Plywood Core -P (\$128.00 per unit) Height: 29"H Top w/ 17"H Stools -STD	15033	\$2,071.95	<input type="text" value="6"/>	\$12,431.70
	Mobile Stool Table w/ Octagonal Top Top: Gray Glace -G Stool Top: Gray -GY Stool Bottom: Black -BK Edge: Dyna Rock Red -DRR (\$50.00 per unit) Frame: Black -BK Plywood: Plywood Core -P (\$87.00 per unit) Height: 29"H Top w/ 17"H Stools -STD	15058	\$1,555.95	<input type="text" value="4"/>	\$6,223.80

Product Subtotal: \$18,655.50

Choose freight delivery service:

- Standard Tailgate
- Liftgate
- Liftgate & Inside Delivery

zip code

Shipping: \$0.00

Are you exempt from state sales tax at the shipping location?: Yes No

Sales Tax: if applicable*

Total: \$18,655.50

*Sales Tax is required on all orders, unless you are state sales tax-exempt and can provide us with a certificate within 2 business days after your order is placed, or already have one on file with us. See notes at checkout to upload, email or fax your certificate. Sales tax may vary slightly once your exact shipping location has been entered.

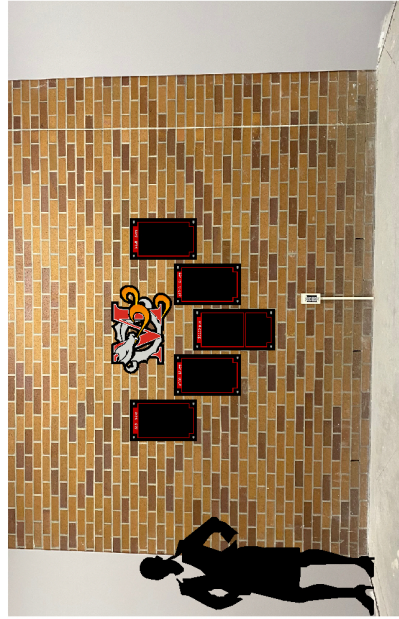
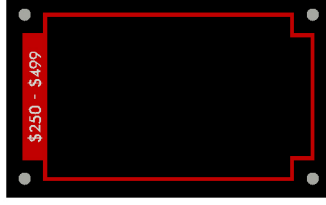
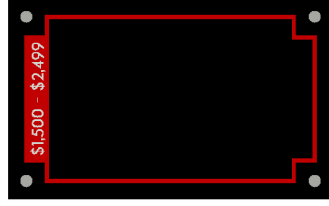
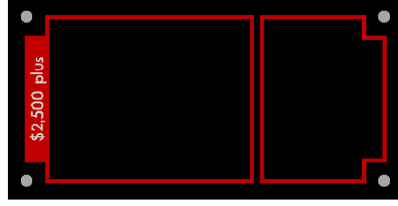
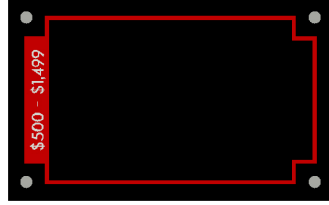
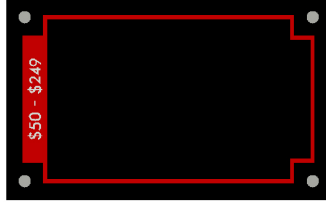

CLIENT:
LOCATION:
SALES PERSON:

ALL RIGHTS RESERVED, NO PART OF THIS DRAWING
 MAY BE REPRODUCED IN ANY FORM WITHOUT WRITTEN
 PERMISSION FROM LOVE SIGN COMPANY.
 © LOVE SIGNS, INC.

COLORS:
 ■ black
 ■ black
 ■ black
 ■ black



lovesignco.com

norfolk · grand island · lincoln

revisions

date

revisions	date

SIGNATURE OF APPROVAL

NOTICE:

BEFORE APPROVING THIS ARTWORK PLEASE CHECK ALL NAMES AND WORDS FOR PROPER SPELLING, AS WELL AS ALL COLORS AND SIGNAGE PLACEMENT IF NECESSARY. QUESTIONS AND OR CHANGES NEED TO BE ADDRESSED BEFORE FINAL APPROVAL. ONCE THE SIGNAGE IS PRODUCED AFTER APPROVAL, ANY AND ALL MISPELLINGS OR COLOR ISSUES ARE THE RESPONSIBILITY OF THE CLIENT AND WILL BE CORRECTED AT THE EXPENSE OF THE PURCHASER.

Love Signs
lovesignco.com
norfolk · grand island · lincoln

revisions date

\$2,500 plus

\$1,500 - \$2,499

\$500 - \$1,499

\$250 - \$499

\$50 - \$249

SIGNATURE OF APPROVAL

NOTICE:
BEFORE APPROVING THIS ARTWORK PLEASE CHECK ALL NAMES AND WORDS FOR PROPER SPELLING, AS WELL AS ALL COLORS AND SIGNAGE PLACEMENT IF NECESSARY. QUESTIONS AND OR CHANGES NEED TO BE ADDRESSED BEFORE FINAL APPROVAL. ONCE THE SIGNAGE IS PRODUCED AFTER APPROVAL, ANY AND ALL MISSPELLINGS OR COLOR ISSUES ARE THE RESPONSIBILITY OF THE CLIENT AND WILL BE CORRECTED AT THE EXPENSE OF THE PURCHASER.



Fw: MADISON donor

Alan Ehlers
Mon 4/20/2020 1:57 PM
To: hhansen@neiasuppl... +6 others

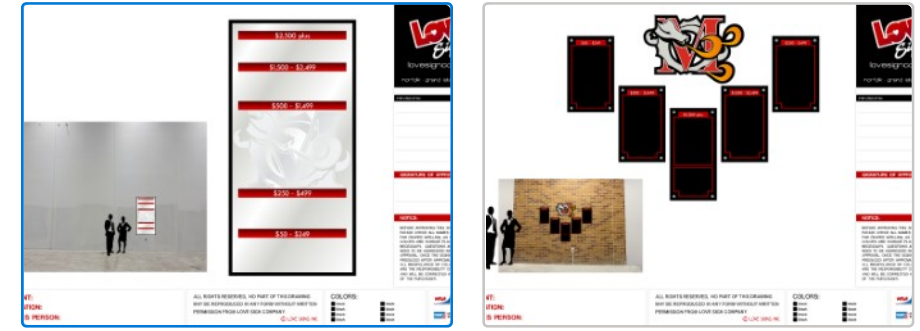

2 attachments (4 MB) Download all

Save all to OneDrive - esu8.org

Two examples of locations and signs for the speaker system. We can talk more about it in the may meeting.

Yours in Education,

Mr. Alan Ehlers
Superintendent
Madison Public Schools
We Are Madison: Where Kids Come First!

*"Coming together is a beginning;
keeping together is progress;
working together is success.*

"Henry Ford"

From: Patti Reigle <preigle@esu8.org>
Sent: Monday, April 20, 2020 1:21 PM
To: Alan Ehlers <aehlers@esu8.org>
Subject: Fw: MADISON donor

CLIENT:
LOCATION:
SALES PERSON:

ALL RIGHTS RESERVED, NO PART OF THIS DRAWING MAY BE REPRODUCED IN ANY FORM WITHOUT WRITTEN PERMISSION FROM LOVE SIGN COMPANY.
© LOVE SIGNS, INC.

COLORS:
■ black
■ black
■ black
■ black
■ black
■ black





MANUFACTURERS OF IDEAS
 Commercial Signs - Sign Service - Billboards
 Electronic Signs - LED Lighting - Awnings - Vehicle ID
 www.lovesignco.com

MANUFACTURING AGREEMENT

<i>In Agreement with</i>			<i>Phone</i>	<i>Estimate Date</i>
Madison Public Schools				4/22/2020
<i>Street</i>			<i>Location</i>	
<i>City</i>	<i>Customer State</i>	<i>Zip Code</i>	<i>City / State</i>	
Madison	Nebraska	68748-	Madison, NE	

Furnish and Install:

Four 19-3/4" by 12-1/4" & one 18" by 26" display panel. Display panels to be 1/4" sintra material, with 1/4" clear acrylic, with brushed aluminum standoffs. Displays to be decorated with digitally printed vinyl. Quote to include 24" by 12-1/4" logo. Logo to be 1/2" sintra material, decorated with digitally printed vinyl. (\$1,497.73)

One 36" by 72" display. Display to be 1/4" sintra material, decorated with digitally printed vinyl. As per customer approved layout. (\$863.80)

Plus applicable sales tax if required.

*Customer is responsible for locating any private underground utility lines.

All signs are custom built products and, at the option of the seller, require payment in advance with order. Installation price is due upon installation. Fifty percent is due upon acceptance and the balance due upon installation. 2% discount if paid in full upon acceptance. Contract prices are guaranteed for 60 days and may be subject to change after that time. AN ADDITIONAL 3% TRANSACTION FEE FOR CREDIT CARD PAYMENTS. (2% Prepay discount does not apply if paying by credit or debit card)

This contract, with all conditions as noted, is herewith accepted by both parties.

Jill Sock

Sales Representative

Love Signs, Inc.

By _____
 Title _____

Madison Public Schools

Purchaser

By _____
 Title _____
 Date _____

NORFOLK
 1805 South 13th Street
 P.O. Box 807
 Norfolk, NE 68701
 402-371-4674

LINCOLN
 3500 Cleveland #2
 Lincoln, NE 68504
 402-325-0293

GRAND ISLAND
 3030 West Old Hwy 30
 P.O. Box 5791
 Grand Island, NE 68802
 308-381-5525

Document G701

PROJECT: (Name and Address) Madison High Phase IV	CHANGE ORDER NUMBER: 7- GYM	OWNER <input type="checkbox"/>
	DATE: 5/6/2020	ARCHITECT <input type="checkbox"/>
	ARCHITECT'S PROJECT NO: 1353	CONTRACTOR <input type="checkbox"/>
TO CONTRACTOR: (Name and Address) dwb, inc PO Box 626 Madison, NE 68748	CONTRACT DATE: 12/11/2018	FIELD <input type="checkbox"/>
	CONTRACT FOR: Phase IV	OTHER <input type="checkbox"/>

The Contract is changed as follows:
(Include, where applicable, any undisputed amount attributable to previously executed Construction Change Directives)

- | | | |
|--|------------|-------------------|
| 1) Revise the Railing on Deck Above Door D21 to Include 8 Horizontal Rails and a Hinged Gate | Add | \$2,161.00 |
|--|------------|-------------------|

Subtotal	<u>\$2,161.00</u>
P & O	<u>\$216.10</u>
Bond	<u>\$26.00</u>

The original Contract Sum was	\$	<u>\$3,592,191.00</u>
The net change by previously authorized Change Orders	\$	<u>\$59,811.18</u>
The Contract Sum prior to this Change Order was	\$	<u>\$3,652,002.18</u>
The Contract Sum will be increased by this Change Order in the amount of	\$	<u>\$2,403.10</u>
The new Contract Sum including this Change Order will be	\$	<u>\$3,654,405.28</u>
The Contract Time will be unchanged by		

(Note: This Change Order does not include changes in the Contract Sum, Contract Time or Guaranteed Maximum Price which have been authorized by Construction Change Directive until the cost and time have been agreed upon by both the Owner and Contractor, in which case a Change Order is executed to supersede the Construction Change Directive.)

NOT VALID UNTIL SIGNED BY THE ARCHITECT, CONTRACTOR AND OWNER.

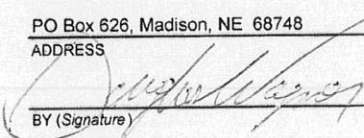
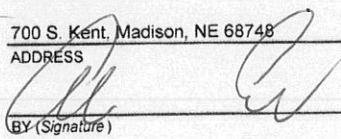
<u>Fakler Architect</u> ARCHITECT (Firm name)	<u>dwb, inc</u> CONTRACTOR (Firm name)	<u>Madison Public Schools</u> OWNER (Firm name)
<u>1001 N 6th St, Beatrice, NE 68310</u> ADDRESS	<u>PO Box 626, Madison, NE 68748</u> ADDRESS	<u>700 S. Kent, Madison, NE 68748</u> ADDRESS
_____ BY (Signature)	 BY (Signature)	 BY (Signature)
<u>Michael Fakler</u> Typed name	<u>Douglas Wagner</u> Typed name	<u>Alan Ehlers</u> Typed name
_____ DATE	<u>5/6/2020</u> DATE	_____ DATE

Document G701

PROJECT: (Name and Address) Madison High Phase IV	CHANGE ORDER NUMBER: 7 - MEZZ	OWNER <input type="checkbox"/>
	DATE: 5/6/2020	ARCHITECT <input type="checkbox"/>
	ARCHITECT'S PROJECT NO: 1353	CONTRACTOR <input type="checkbox"/>
TO CONTRACTOR: (Name and Address) dwb, inc PO Box 626 Madison, NE 68748	CONTRACT DATE: 12/11/2018	FIELD <input type="checkbox"/>
	CONTRACT FOR: Phase IV	OTHER <input type="checkbox"/>

The Contract is changed as follows:
(Include, where applicable, any undisputed amount attributable to previously executed Construction Change Directives)

1) Add Poplar Cap Board with Apron to the Ledge at Handicap Ramp	Add	662.00
--	-----	--------

Subtotal	\$662.00
P & O	\$66.20
Bond	\$8.00

The original Contract Sum was	\$ 1,678,133.00
The net change by previously authorized Change Orders	\$ 57,114.74
The Contract Sum prior to this Change Order was	\$ 1,735,247.74
The Contract Sum will be increased by this Change Order in	\$ 736.20
the amount of	\$ 1,735,983.94
The new Contract Sum including this Change Order will be	\$
The Contract Time will be unchanged by	

(Note: This Change Order does not include changes in the Contract Sum, Contract Time or Guaranteed Maximum Price which have been authorized by Construction Change Directive until the cost and time have been agreed upon by both the Owner and Contractor, in which case a Change Order is executed to supersede the Construction Change Directive.)

NOT VALID UNTIL SIGNED BY THE ARCHITECT, CONTRACTOR AND OWNER.

<u>Fakler Architect</u> ARCHITECT (Firm name)	<u>dwb, inc</u> CONTRACTOR (Firm name)	<u>Madison Public Schools</u> OWNER (Firm name)
<u>1001 N 6th St, Beatrice, NE 68310</u> ADDRESS	<u>PO Box 626, Madison, NE 68748</u> ADDRESS	<u>700 S. Kent, Madison, NE 68748</u> ADDRESS
<u>[Signature]</u> BY (Signature)	<u>[Signature]</u> BY (Signature)	<u>[Signature]</u> BY (Signature)
<u>Michael Fakler</u> Typed name	<u>Douglas Wagner</u> Typed name	<u>Alan Ehlers</u> Typed name
<u>DATE</u>	<u>5/6/2020</u> DATE	<u>DATE</u>