

Agenda of Public Hearing and Regular Meeting

The Board of Trustees Galveston Independent School District

A Public Hearing on GISD's 2019-2020 Financial Integrity Rating System of Texas will begin at 6:30 in the Board Room of the Lovenberg Administration Building, 3904 Avenue T, Galveston, TX. The Assistant Superintendent of Business and Operations, Connie Morgenroth, will present the 2019-2020 Annual Financial Management Report and will go over GISD's School FIRST accountability rating for the August 31, 2019 fiscal year.

A Regular meeting of the Board of Trustees of Galveston Independent School District will be held immediately following the Public Hearing.

Notice was given pursuant to Texas Government Code Section 551.127 as modified by the Texas Attorney General, that due to the state of emergency declared by, Governor Abbott on behalf of the State of Texas, and President Trump on behalf of the United States of America regarding the spread of coronavirus/COVID-19 (hereafter "COVID-19"), one or more members of the Galveston ISD Board of Trustees may have attended this meeting via videoconference in order to properly mitigate the spread of COVID-19, pursuant to State and local emergency/disaster declarations. Notice was given that Galveston ISD intended to conduct this meeting via videoconference. As required by the temporary suspension, Galveston ISD:

- Has provided online written notice containing a free-of-charge website link, as well as an electronic copy of any agenda packet, before conducting this meeting via videoconference; specifically, the public may use the following free-of-charge website link: <https://www.gisd.org/site/Default.aspx?PageID=5397>; or a live broadcast on Channel 17.
- Provided the public with access and a means to participate in the meeting, at 3904 Ave T Galveston, TX 77550; or by telephone at 409-766-5139; and
- Provided the public with access to a recording of the meeting.

The subjects discussed or considered or upon which any formal action may be taken are as listed below. Items do not have to be taken in the order shown.

- 1) Public Hearing on GISD's 2019-2020 Financial Integrity Rating System of Texas 4
- 2) Call to order Open Session in the Board Room of the Lovenberg Administration Building, 3904 Avenue T, Galveston, Texas.
- 3) Pledge of Allegiance to the United States flag and the Texas flag.
- 4) Citizen's Request to Address the Board on Agenda and Non-Agenda Items. Please complete sign-up sheets available in the lobby prior to the start of the meeting.
- 5) Superintendent's Report
 - A) Campus Highlights - Parker and Oppe

B) MECC Quarterly Report	32
C) Update on Returning to Learning	
D) Previously Requested Information by the Board:	
E) Board Committee Reports	
1) Policy Committee Chair- Mr. David O'Neal	
2) Curriculum Committee Chair- Ms. Monica Wagner	
3) Facilities/Finance Committee Chair- Mr. Johnny Smecca	
6) Financial Reports	52
7) The Board may recess into Closed Executive Session in the Library as permitted by the Texas Open Meeting Act Government Code Sections 551.071- 551.090 Subchapter D and E.	
Should any final action, final decision, or final vote be required in the opinion of the School Board with regard to any matter considered in such closed meeting then the final action, final decision, or final vote shall be either:	
A) in the open meeting covered by the Notice upon the reconvening of the public meeting;	
or	
B) at a subsequent public meeting of the School Board upon notice thereof; as the School Board shall determine.	
A) Personnel	
B) Consultation with Attorney	
C) Real Property	
8) Board President to Appoint Standing Committees	
9) CONSENT AGENDA - Action Items	
A) Consider approval of the minutes from the Regular School Board Meeting on November 18, 2020.	95
B) Consider approval of the Board's Time Use Tracker - November 18, 2020	100
C) Consider approval of personnel resignations and recommendations with contracts.	106
D) Consider approval of Monthly Budget Amendments	107
E) Consider Approval of Purchases >\$50,000.	109
F) Attorney Fees	156
G) Discuss and consider approval of \$8,164 Change Order Increase to JW Kelso's contract for Crenshaw and MS Campus Improvements.	157
H) Discuss and consider approval for construction of Crenshaw outdoor environmental classroom as outlined in APEX 3 Magnet Grant. Amount not to exceed \$57,500 using Grant funds.	162
I) Discuss and consider approval of resolution to extend use of sick leave in accordance with the FFCRA.	171
J) Discuss and consider purchase of 4 school buses in an amount not to exceed \$469,976.	173
K) Discuss and consider approval of \$25,000 change order decrease to CFI Mechanical's contract for the District-Wide MEP Renovation Project.	190
10) REGULAR AGENDA- Action Items	
A) Discuss and approve the 2021-2022 School Calendar.	192

B) Discuss and consider elimination of any admissions process for GISD schools that utilizes a matrix to sort and rank students.	194
C) Discuss and consider reconfiguration of GISD middle schools to establish a single 7/8 grade campus at Central Middle School.	195
D) Discuss and consider approval of the August 31, 2020 Annual Financial and Compliance Report.	196
E) Discuss and Consider Naming the Lone Finalist for Superintendent of Schools.	197
11) Board Comments	
12) Adjournment	

If, during the course of the meeting, discussion of any item on the agenda should be held in a closed meeting, the Board will conduct a closed meeting in accordance with the Texas Open Meetings Act, Government Code, Chapter 551, Subchapters D and E. Before any closed meeting is convened, the presiding officer will publicly identify the section or sections of the Act authorizing the closed meeting. All final votes, actions, or decisions will be taken in open meeting.

The notice for this meeting was posted in compliance with the Texas Open Meeting Act on _____, at _____

For the Board of Trustees

Galveston Independent School District
2020 Annual Financial Management Report
School Financial Integrity Rating System of Texas
“FIRST”

For the Year Ending August 31, 2019



Dr. Kelli Moulton, Superintendent

Connie Morgenroth, Assistant Superintendent of Business and Operations

December 16, 2020

**Galveston Independent School District
2020 Annual Financial Management Report
School FIRST
For the Year Ending August 31, 2019**

Table of Contents

Introduction	1
2019-2020 FIRST Rating	3
Overview of the Worksheet	6
Critical Indicators #1 - #5	6-7
All Other Indicators #6 - #15	8-11
Required Disclosures	12

**Galveston Independent School District
2020 Annual Financial Management
Report – School FIRST**

Introduction

During the 77th regular session of the Texas legislature (2001), Senate Bill 218 was passed and Governor Perry signed it into law shortly thereafter. This law requires each school district to prepare an annual financial management report within two months of the date of issuance of the final School FIRST ratings. The District received official notification of the 2019-2020 Final School FIRST rating on November 6, 2020. This rating is based upon analysis of school year data for the fiscal year ending August 31, 2019.

The purpose of the financial accountability rating system is to ensure that school districts will be held accountable for the quality of their financial management practices and achieve improved performance in the management of their financial resources. The system is designed to encourage Texas public schools to manage their financial resources better in order to provide the maximum allocation possible for direct instructional purposes. The system also discloses the quality of local management and decision-making processes that impact the allocation of financial resources in Texas public schools. An evaluation of the long-term effectiveness of the system should disclose a measurable improvement in the quality of Texas public schools' decision-making processes.

The primary reporting tool is the Financial Accountability Ratings Worksheet. This worksheet was originally developed by representatives of the Texas Education Agency (TEA), the Texas Business & Education Council (TBEC) and the Texas Association of School Business Officials (TASBO). It is administered by the TEA and calculated on information submitted to the Agency via our PEIMS submission each year.

This year's report includes changes made by the Commissioner's Rule that were finalized in August 2018. The most substantive changes will be implemented by the Texas Education Agency beginning with ratings year 2020-2021 based primarily on data from fiscal year 2020. During the phase-in period, the new School FIRST system has separate worksheets for rating years 2017-2018, 2018-2019, and 2019-2020 as compared to subsequent years.

Under School FIRST, every school district in Texas is required to prepare an annual financial management report that includes the following:

- The district's financial management performance rating provided by the Texas Education Agency (TEA) based on its comparison with indicators established by the Commissioner of Education for the state's new Financial Accountability System;
- The district's financial management performance under each indicator for the current and previous years' financial accountability ratings;
- Additional information required by the Commissioner of Education (disclosures)

Starting with the 2007 calendar year, the financial management report must contain certain required disclosures, in accordance with Title 19 of the Texas Administrative Code, Chapter 109, Budgeting, Accounting, and Auditing Subchapter AA, Commissioner's Rules Concerning the Financial Accountability Rating System. These disclosures are as follows:

1. A copy of the Superintendent's current employment contract (this can be satisfied by placing the contract on the district website);
2. A summary schedule for the fiscal year of total reimbursements received by the superintendent and each board member;
3. A summary schedule for the fiscal year of the dollar amount compensation and/or fees received by the Superintendent from another school district or any outside entity in exchange for professional consulting and/or other personal services;
4. A summary schedule for the fiscal year of the total dollar amount by the executive officers and board members of gifts that had an economic value of \$250 or more;
5. A summary schedule for the fiscal year of the dollar amount by board member for the aggregate amount of business transactions with the school district.

Currently, the worksheet consists of 15 Indicators, each weighted equally with the exception of the Critical Indicators. A "No" response in Indicators #1, #2.A, #3, or #4 will automatically result in a rating of Substandard Achievement, so these first four Indicators are of utmost importance.

In summary, Galveston ISD received the rating of "**A = Superior**", scoring a 96 out of a possible 100 on the financial accountability worksheet. Indicators #6 related to the number of days' cash on hand and #11 administrative cost ratio were both decreased by 2 points, earning 8 out of a possible 10, which led to the score. The District received the maximum points on all other indicators. The worksheet itself follows, along with an explanation of each indicator, the indicator goal, and GISD's performance this year as compared to last year. Finally, as in accordance with Title 19, the required disclosures are included at the back of the report.

Financial Integrity Rating System of Texas

2019-2020 RATINGS BASED ON SCHOOL YEAR 2018-2019 DATA - DISTRICT STATUS DETAIL

Name: GALVESTON ISD(084902)	Publication Level 1: 8/6/2020 9:26:37 AM
Status: Passed	Publication Level 2: 8/6/2020 11:17:34 AM
Rating: A = Superior	Last Updated: 8/6/2020 11:17:34 AM
District Score: 96	Passing Score: 60

#	Indicator Description	Updated	Score
1	<u>Was the complete annual financial report (AFR) and data submitted to the TEA within 30 days of the November 27 or January 28 deadline depending on the school district's fiscal year end date of June 30 or August 31, respectively?</u>	3/30/2020 1:16:18 PM	Yes
2	Review the AFR for an unmodified opinion and material weaknesses. The school district must pass 2.A to pass this indicator. The school district fails indicator number 2 if it responds "No" to indicator 2.A. or to both indicators 2.A and 2.B.		
2.A	<u>Was there an unmodified opinion in the AFR on the financial statements as a whole? (The American Institute of Certified Public Accountants (AICPA) defines unmodified opinion. The external independent auditor determines if there was an unmodified opinion.)</u>	3/30/2020 1:16:18 PM	Yes
2.B	<u>Did the external independent auditor report that the AFR was free of any instance(s) of material weaknesses in internal controls over financial reporting and compliance for local, state, or federal funds? (The AICPA defines material weakness.)</u>	3/30/2020 1:16:19 PM	Yes
3	<u>Was the school district in compliance with the payment terms of all debt agreements at fiscal year end? (If the school district was in default in a prior fiscal year, an exemption applies in following years if the school district is current on its forbearance or payment plan with the lender and the payments are made on schedule for the fiscal year being rated. Also exempted are technical defaults that are not related to monetary defaults.</u>	3/30/2020 1:16:19 PM	Yes

	<u>A technical default is a failure to uphold the terms of a debt covenant, contract, or master promissory note even though payments to the lender, trust, or sinking fund are current. A debt agreement is a legal agreement between a debtor (= person, company, etc. that owes money) and their creditors, which includes a plan for paying back the debt.)</u>		
4	<u>Did the school district make timely payments to the Teachers Retirement System (TRS), Texas Workforce Commission (TWC), Internal Revenue Service (IRS), and other government agencies?</u>	3/30/2020 1:16:19 PM	Yes
5	This indicator is not being scored.		
6	<u>Was the number of days of cash on hand and current investments in the general fund for the school district sufficient to cover operating expenditures (excluding facilities acquisition and construction)? (See ranges below.)</u>	3/30/2020 1:16:20 PM	8
7	<u>Was the measure of current assets to current liabilities ratio for the school district sufficient to cover short-term debt? (See ranges below.)</u>	3/30/2020 1:16:20 PM	10
8	<u>Was the ratio of long-term liabilities to total assets for the school district sufficient to support long-term solvency? If the school district's increase of students in membership over 5 years was 7 percent or more, then the school district passes this indicator. See ranges below.</u>	3/30/2020 1:16:21 PM	10
9	<u>Did the school district's general fund revenues equal or exceed expenditures (excluding facilities acquisition and construction)? If not, was the school district's number of days of cash on hand greater than or equal to 60 days?</u>	3/30/2020 1:16:21 PM	10
10	<u>Was the debt service coverage ratio sufficient to meet the required debt service? (See ranges below.)</u>	3/30/2020 1:16:22 PM	10
11	<u>Was the school district's administrative cost ratio equal to or less than the threshold ratio? (See ranges below.)</u>	3/30/2020 1:16:23 PM	8
12	<u>Did the school district not have a 15 percent decline in the students to staff ratio over 3 years</u>	3/30/2020 1:16:23 PM	10

	<u>(total enrollment to total staff)? (If the student enrollment did not decrease, the school district will automatically pass this indicator.)</u>		
13	<u>Did the comparison of Public Education Information Management System (PEIMS) data to like information in the school district's AFR result in a total variance of less than 3 percent of all expenditures by function?</u>	3/30/2020 1:16:26 PM	10
14	<u>Did the external independent auditor indicate the AFR was free of any instance(s) of material noncompliance for grants, contracts, and laws related to local, state, or federal funds? (The AICPA defines material noncompliance.)</u>	3/30/2020 1:16:26 PM	10
15	<u>Did the school district not receive an adjusted repayment schedule for more than one fiscal year for an over allocation of Foundation School Program (FSP) funds as a result of a financial hardship?</u>	3/30/2020 1:16:27 PM	10
			96 Weighted Sum
			1 Multiplier Sum
			96 Score

DETERMINATION OF RATING

A.	Did the district answer ' No ' to Indicators 1, 3, 4, or 2.A? If so, the school district's rating is F for Substandard Achievement regardless of points earned.
B.	Determine the rating by the applicable number of points. (Indicators 6-15)
	A = Superior 90-100
	B = Above Standard 80-89
	C = Meets Standard 60-79
	F = Substandard Achievement <60

Overview of the Worksheet

Critical Indicators

Indicators 1 through 5 are considered critical indicators. Any “No” response in one of these categories is a signal indicator of fiscal distress. These five indicators revolve around the audit report, timely debt and payroll-related payments and the auditor’s findings.

Indicator #1

Indicator: Was the complete annual financial report (AFR) and data submitted to the TEA within 30 days of the November 27 or January 28 deadline depending on the school district’s fiscal year end date of June 30 or August 31, respectively?

Indicator Goal: To ensure the district’s financial report is filed by the deadline.

GISD Answer: Yes. Like last year, the District met this requirement. The annual financial report was received by the Texas Education Agency before the required deadline of January 28, 2020.

Indicator #2 (consists of 2.A. and 2.B.)

Indicator #2. A.: Was there an unmodified opinion in the AFR on the financial statements as a whole? The school district must pass 2.A. to pass indicator number 2. The district fails indicator number 2 if it responds “No” to indicator 2.A. or to both indicators 2.A. and 2.B.

Indicator Goal: To determine whether the annual financial report is free from material misstatement.

GISD Answer: Yes. Like last year, the District received an unqualified opinion in its annual financial report.

Indicator #2. B.: Did the external independent auditor report that the AFR was free of any instance(s) of material weaknesses in internal controls over financial reporting and compliance for local, state, or federal funds?

Indicator Goal: To determine whether the district has established and maintains effective internal control over its financial reporting.

GISD Answer: Yes. Like last year, the annual financial report did not disclose any instances of material weaknesses in internal controls.

Indicator #3

Indicator: Was the school district in compliance with the payment terms of all debt agreements at fiscal year end?

Indicator Goal: To determine if the district made its outstanding bond payments on time and to ensure it is not in default.

GISD Answer: Yes. Like last year, GISD made all required bond payments on time.

Indicator #4

Indicator: Did the school district make timely payments to the Teachers Retirement System (TRS), Texas Workforce Commission (TWC), Internal Revenue Service (IRS), and other governmental agencies?

Indicator Goal: To determine if the district fulfilled its payroll-related payment obligations to these organizations.

GISD Answer: Yes. Like last year, GISD made all payroll-related payment obligations on time.

Indicator #5

Indicator: Was the total unrestricted net position balance (net of the accretion of interest for capital appreciation bonds) in the governmental activities column in the Statement of Net Positions greater than zero?

Indicator Goal: This indicator is not being scored per TEA.

All Other Indicators

Indicator #6

Indicator: Was the number of days of cash on hand and current investments in the general fund for the school district sufficient to cover operating expenditures (excluding facilities acquisition and construction)?

Indicator Goal: This indicator measures how long in days after the end of the fiscal the school district could have disbursed funds for its operating expenditures without receiving any new revenues. Districts must have more than 90 days to receive all 10 points, and points decrease by 2 as the number of days' decreases.

GISD Answer: Yes. This year, the District received 8 of 10 points, as compared to 6 of 10 points last year. We had 87.8 days this year versus 63.6 days last year.

Indicator #7

Indicator: Was the measure of current assets to current liabilities ratio for the school district sufficient to cover short-term debt?

Indicator Goal: This indicator measures whether the school district had sufficient short-term assets at the end of the fiscal year to pay off its short-term liabilities. To earn the maximum of 10 points, current assets must be more than 3 times current liabilities, and points decrease by 2 as the ratio decreases.

GISD Answer: 4.3247; therefore, GISD earned all 10 points this year, as well as last year. Current Assets \$70,108,833 / Current Liabilities \$16,211,205 = 4.3247. Last year's ratio was 7.8638.

Indicator #8

Indicator: Was the ratio of long-term liabilities to total assets for the school district sufficient to support long-term solvency?

Indicator Goal: This question seeks to determine the amount of long-term debt relative to total assets. Fast growth districts pass this indicator if their enrollment has increased more than 10% in 5 years. To receive all 10 points, the long-term debt (net of pension liability) cannot be >60% of total assets, and points decrease as the percentage increases.

GISD Answer: 47.86% therefore, the District received all 10 points on this indicator. LT Liabilities 68,990,412 / Total Assets 144,145,265 = .4786. GISD also received 10 points with 50.86% on this indicator last year.

Indicator #9

Indicator: Did the school district's general fund revenues equal or exceed expenditures (excluding facilities acquisition and construction)? If not, was the school district's number of days of cash on hand greater than or equal to 60 days?

Indicator Goal: To determine if the District spent more than it earned. The school district will automatically pass this indicator if it had at least 60 days' cash on hand.

GISD Answer: 10 of 10 points. GISD passed both parts of this indicator both this year and last; revenues exceeded expenditures, and the District had 87.8 days' cash on hand this year and 63.6 days' cash on hand last year.

Indicator #10

Indicator: Was the debt service coverage ratio sufficient to meet the required debt service?

Indicator Goal: To determine the District's ability to make its debt principal and interest payments due during the year. A ratio of >1.20 earns all 10 points, and the points decrease by 2 as the ratio declines.

Answer: Like last year, GISD received all 10 points. GISD's debt service coverage ratio was 2.4876 this year and 2.2088 last year.

Indicator #11

Indicator: Was the school district's administrative cost ratio equal to or less than the threshold ratio?

Indicator Goal: To determine whether the district's administrative costs are in an acceptable range for its size. For GISD, a ratio of $<10\%$ earns all 10 points, and the points decrease by 2 as the percentage increases.

GISD Answer: 8 of 10 points. GISD's administrative cost ratio is 10.49%. Last year, our ratio was 11.54% and we also earned 8 points.

Indicator #12

Indicator: Did the school district not have a 15 percent decline in the students to staff ratio over 3 years (total enrollment to total staff)? (If the student enrollment did not decrease, the school district will automatically pass this indicator.)

Indicator Goal: To determine that if student enrollment is declining by more than 15%, staff are also decreasing proportionately, over a 3-year period.

GISD Answer: 10 out of 10 points both this year, and last year. GISD is not experiencing a large decline in enrollment.

Indicator #13

Indicator: Did the comparison of PEIMS data to like information in the school district's AFR result in a total variance of less than 3 percent of all expenditures by function?

Indicator Goal: To determine whether the quality of data reported to TEA through PEIMS and in the annual financial report submission are consistent. If the variance is greater than 3%, districts fail this indicator.

GISD Answer: Like last year, GISD received all 10 points on this indicator. Our variance was .03 percent for both years.

Indicator #14

Indicator: Did the external independent auditor indicate the AFR was free of any instance(s) of material noncompliance for grants, contracts, and laws related to local, state, or federal funds?

Indicator Goal: An audit finding of material non-compliance could indicate a risk of internal weaknesses and signal that public funds are not being properly handled.

GISD Answer: Like last year, GISD did not have any audit findings of material non-compliance and received all 10 points on this Yes or No indicator.

Indicator #15

Indicator: Did the school district not receive an adjusted repayment schedule for more than one fiscal year for an over allocation of Foundation School Program (FSP) funds as a result of a financial hardship?

Indicator Goal: To determine if the district had to ask for an easy payment plan to return monies to TEA after spending the overpayment in state aid from the Foundation School Program.

GISD Answer: Like last year, GISD did not receive an adjusted repayment schedule for overpayments from TEA and received all 10 points on this Yes or No indicator.

DETERMINATION OF RATING

A.	Did the district answer 'No' to Indicators 1, 3, 4, or 2.A? If so, the school district's rating is F for Substandard Achievement regardless of points earned.								
B.	Determine the rating by the applicable number of points. (Indicators 6-15)								
	<table border="1"><tr><td>A = Superior</td><td>90-100</td></tr><tr><td>B = Above Standard</td><td>80-89</td></tr><tr><td>C = Meets Standard</td><td>60-79</td></tr><tr><td>F = Substandard Achievement</td><td><60</td></tr></table>	A = Superior	90-100	B = Above Standard	80-89	C = Meets Standard	60-79	F = Substandard Achievement	<60
A = Superior	90-100								
B = Above Standard	80-89								
C = Meets Standard	60-79								
F = Substandard Achievement	<60								

REQUIRED DISCLOSURES

Summary Schedule of Reimbursements as of August 31, 2019

Description	Kelli Moulton	Anthony Brown	Shae Jobe	Matthew Hay	David O'Neal	Johnny Smecca	Mindy Lakin	Monica Wagner
Meals	\$ 255.37	\$	\$ 10.54	\$ 52.00	\$ 251.00	\$	\$	\$
Lodging								
Transportation	\$ 2,274.59	\$349.74	\$ 83.57	\$ 351.78	\$ 256.58	\$ 342.20		
Motor Fuel								
Other								
Total	<u>\$ 2,529.96</u>	<u>\$349.74</u>	<u>\$ 94.11</u>	<u>\$ 403.78</u>	<u>\$ 507.58</u>	<u>\$ 342.20</u>	<u>\$ -</u>	<u>\$ -</u>

Other includes registration fees and hotel internet services.

Business Transactions Between School Districts and Board Members for FY 2019

There were no business transactions between the District and any board member for FY 2019.

Superintendent Outside Compensation

Superintendent Kelli Moulton, did not receive any outside compensation or fees for Professional Consulting or other personal services for the twelve-month period ended August 31, 2019.

Superintendent's Contract

The Superintendent's current contract is posted on the District's website at GISD.org.

Executive Officer and Board of Trustees Gifts

The Superintendent and Board Members did not receive any gifts that had an economic value of \$250 or more in aggregate for the twelve-month period ended August 31, 2019 from an outside entity that received payments from GISD in the prior fiscal year or from competing vendors that were not awarded contracts in the prior fiscal year.



Galveston ISD

2020 Annual Financial Management Report

For the Year Ending August 31, 2019

What is School FIRST and What is its Purpose?

- School FIRST is a financial accountability rating system that holds school districts accountable for the quality of their financial management practices.
- School FIRST is designed to encourage Texas public schools to manage their financial resources better in order to provide the maximum allocation possible for direct instructional purposes.
- School FIRST is a tool that creates transparency and discloses the quality of local management and decision making processes that the school district uses concerning the financial resources the school district receives.

Reporting Requirements

- Annual preparation and distribution of a financial management report to the Board of Trustees
- Public hearing to provide an opportunity for public comment on the report

2020 Ratings

- 2020 Ratings are based on FY 2019 data
- 15 indicators
 - 5 considered “critical”
 - No answer to any except 2.B. results in automatic rating of Substandard Achievement
- 4 Ratings with letter grades:
 - A = Superior (90-100 points)
 - B = Above Standard (80-89)
 - C = Meets Standard (60-79)
 - F = Substandard Achievement (<60)



Galveston ISD Score:
96 out of 100 points

Rating:

A = SUPERIOR

Critical Indicators

#	Indicator Description	FY 2019 Data	FY 2018 Data
1	Was the complete annual financial report (AFR) and data submitted to the TEA within 30 days of the November 27 or January 28 deadline depending on the school district's fiscal year end date of June 30 or August 31, respectively?	YES	YES
2	Was there an unmodified opinion in the AFR on the financial statements as a whole and was it free of any instances of material weakness in internal controls over financial reporting?	YES	YES
3	Was the school district in compliance with the payment terms of all debt agreements at fiscal year end?	YES	YES
4	Did the school district make timely payments to the Teachers Retirement System (TRS), Texas Workforce Commission (TWC), Internal Revenue Service (IRS), and other governmental agencies?	YES	YES
5	Was the total unrestricted net asset balance (Net of the accretion of interest for capital appreciation bonds) in the governmental activities column in the Statement of Net Assets greater than zero?	Not Scored	Not Scored

Solvency Indicators

#	Indicator Description	FY 2019 Data	FY 2018 Data
6	Was the number of days of cash on hand and current investments in the general fund for the school district sufficient to cover operating expenditures (excluding facilities acquisition and construction)?	8	6
7	Was the measure of current assets to current liabilities ratio for the school district sufficient to cover short-term debt?	10	10
8	Was the ratio of long-term liabilities to total assets for the school district sufficient to support long-term solvency?	10	10
9	Did the school district's general fund revenues equal or exceed expenditures (excluding facilities acquisition and construction)? If not, was the school district's number of days of cash on hand greater than or equal to 60 days?	10	10
10	Was the debt service coverage ratio sufficient to meet the required debt service?	10	10
11	Was the school district's administrative cost ratio equal to or less than the threshold ratio?	8	8

Solvency Indicators

#	Indicator Description	2018-2019 Data	2017-2018 Data
12	Did the school district not have a 15 percent decline in students to staff ratio over 3 years (total enrollment to total staff)? (If the student enrollment did not decrease, the school district will automatically pass this indicator.)	10	10
13	Did the comparison of Public Education Information Management System (PEIMS) data to like information in the school district's AFR result in a total variance of less than 3 percent of all expenditures by function?	10	10
14	Did the external independent auditor indicate the AFR was free of any instance(s) of material noncompliance for grants, contracts, and laws related to local, state, or federal funds?	10	10
15	Did the school district not receive an adjusted repayment schedule for more than one fiscal year for an over-allocation of Foundation School Program (FSP) funds as a result of a financial hardship?	10	10
TOTAL RATING:		96	94

Required Disclosures

- Schedule of Reimbursements made to the Superintendent and all Board Members is disclosed in the report
- There were no business transactions between the District and any board members
- The Superintendent did not receive any outside compensation or consulting fees
- The Superintendent and board members did not receive any reportable gifts >\$250
- The Superintendent's contract is posted on the GISD website

School FIRST Changes

- Fiscal Years 2017-18, 2018-19 and 2019-20 were transition years
- Majors changes coming with the 2020-21 rating
- 2020-2021 rating will include 21 indicators
 - 5 critical indicators remain
 - Introduction of a new type of indicator, designated as a “ceiling indicator”, that limits the maximum number of points if certain ceiling criteria are not met and can limit the highest achievable rating

District Rating Changes

2019-20 Rating Year Data FY 19	
# of Indicators	15
Ratings:	Points:
A – Superior	90 – 100
B – Above Standard	80 – 89
C – Meets Standard	60 – 79
F – Substandard	0 – 59

2020-21 Rating Year Data FY 20	
# of Indicators	21
Ratings:	Points:
A – Superior	90 – 100
B – Above Standard	80 – 89
C – Meets Standard	70 – 79
F – Substandard	0 – 69

Solvency Indicator Changes

#	Indicator Description
6	Was the average change in (assigned and unassigned) fund balances over 3 years less than a 25 percent decrease or did the current year's assigned and unassigned fund balances exceed 75 days of operational expenditures?
10	Did the school district average less than a 10 percent variance (90%-110%) when comparing budgeted revenues to actual revenues for the last 3 fiscal years? *Indicator #10 will not be included in 2020-21 scoring due to COVID related uncertainties
12	Was the debt per \$100 of assessed property value ratio sufficient to support future debt payments?

Financial Competency Indicator Changes

#	Indicator Description
15	<p>Was the school district's actual average daily attendance (ADA) within the allotted range of the district's biennial pupil projection submitted to TEA?</p> <p>*Indicator #15 will not be included in 2020-21 scoring due to COVID related uncertainties</p>
17	<p>Did the external independent auditor report that the AFR was free of any instance(s) of material weaknesses in internal controls over financial reporting and compliance for local, state, or federal funds? (formerly a portion of indicator 2)</p>
19	<p>Did the school district post the required financial information on its website in accordance with Government Code, Local Government Code, Texas Education Code, Texas Administrative Code and other statutes, laws and rules? (i.e. tax rate posting)</p>
20	<p>Did the school board members discuss the district's property values at a board meeting within 120 days before the district adopted its budget?</p>



QUESTIONS?



DECEMBER
2020



MOODY EARLY CHILDHOOD CENTER



FIRST QUARTERLY REPORT



Enrollment



Enrollment

Category	Infant & Toddler	PK
Hispanic	25%	43%
AA	11%	32%
Caucasian	56%	19%
Other	9%	6%
SES	49%	85%
Full Pay	51%	15%

Classrooms	Ages	Number of Classrooms	Enrollment
Infants	6 wks - 23 months	7	36
Toddlers	24 months-36 months	5	27
PreK3	3 - 4 years	6	64
PreK4	4 - 5 years	5	36
Virtual PK	PK3/PK4	1	1/4
GISD	Kindergarten	1	2
Afterschool Care	PK-1 st	4	35

**Still have openings in all areas.
Recruitment continuing.**

Staff

Moody
Early Childhood
Center



Staff

Demographics

Hispanic - 33%

AA - 19%

Caucasian - 45%

Other - 3%



Staff Education Level

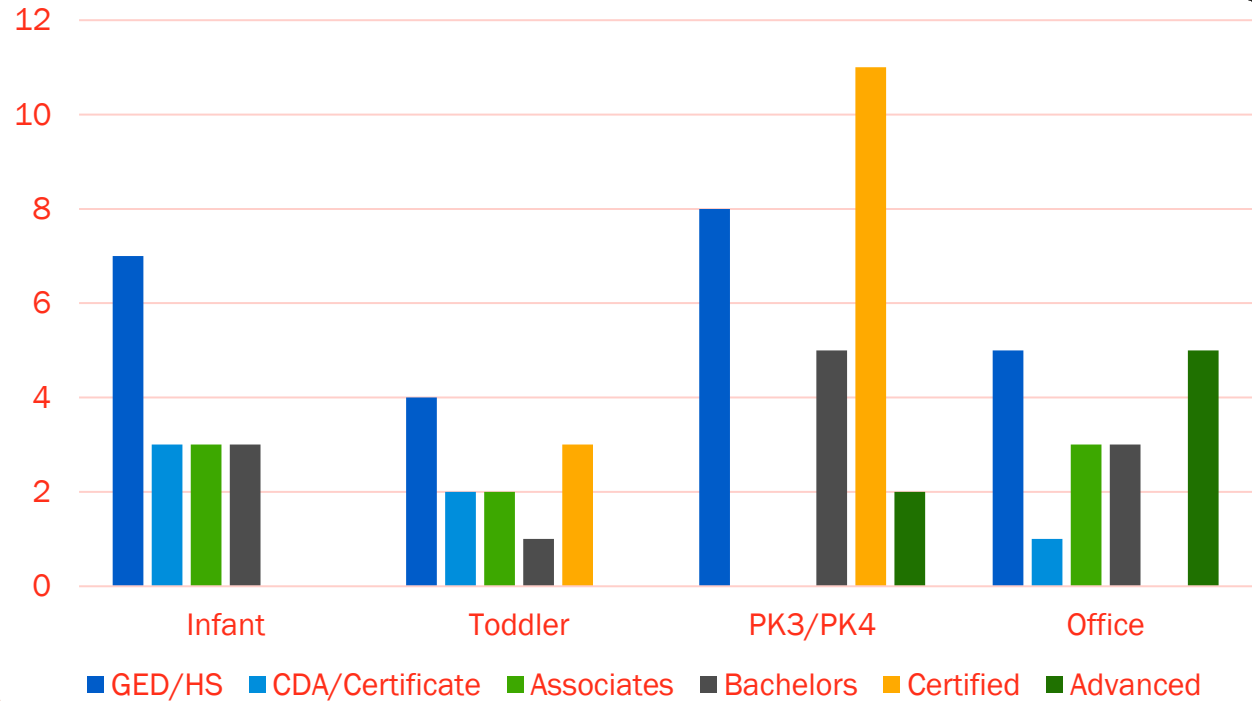

Academic Performance



Academic Performance: IT



Age	6 wks – 5 months				6 - 11 months				12 - 17 months				18 - 23 months				24 - 36 months				36 months+			
	Oct	Jan	Apr	Jul	Oct	Jan	Apr	Jul	Oct	Jan	Apr	Jul	Oct	Jan	Apr	Jul	Oct	Jan	Apr	Jul	Oct	Jan	Apr	Jul
Health & Motor	67				73				80				43				46				71			
Lang & Lit	67				18				20				14				48				79			
Social Emotion	100				82				40				71				82				100			
Cognitive	67				64				10				57				55				86			
Overall	67				36				10				43				27				79			

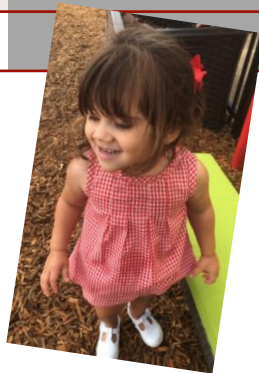

Academic Performance: PK3



Skills Assessed	1 st Assessment	2 nd Assessment	3 rd Assessment	EOY	New Students	Returning Students
Capital Letter (10)	24%				16%	44%
Lower Case (10)	17%				14%	28%
Number (1-5)	34%				27%	50%
Rote Counting (1-15)	30%				30%	44%
Colors (11)	39%				30%	67%
Shapes (6)	59%				55%	78%



Academic Performance: PK4



Skills Assessed	1 st Assessment	2 nd Assessment	3 rd Assessment	EOY	New Students	Returning Students
Capital Letter (20)	52%				29%	58%
Lower Case (20)	52%				29%	58%
Number (1-10)	55%				29%	65%
Rote Counting (1-30)	48%				43%	65%
Colors (11)	63%				57%	68%
Shapes (6)	82%				71%	97%



Academic Performance: PK3



New Students



Returning Students



Academic Performance: PK4

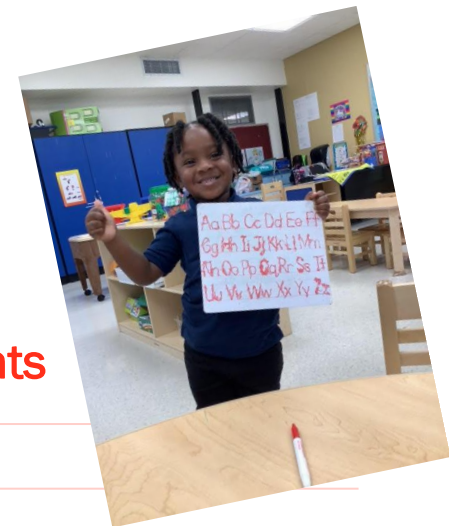

New Students



Returning Students



Student Outcome Goals



Student Outcome Goals: PK3



- **Increase Vocabulary** – By the end of the 2020-2021 school year, 80% of our students will be able to identify vocabulary introduced in the Frog Street curriculum (90 vocabulary cards)

6% Oct

- **Alphabet Knowledge** – By the end of the 2020-2021 school year, 80% of our students will recognize at least 10 letters especially those in their own name.

24% Oct

- **Number Recognition** – By the end of the 2020-2021 school year, 80% of our students will recognize the numerals 1-5.

34% Oct



Student Outcome Goals: PK4



- **Increase Vocabulary** – By the end of the 2020-2021 school year, 80% of our students will be able to identify vocabulary introduced in the Frog Street curriculum (138 vocabulary cards)

3% Oct

- **Alphabet Knowledge** – By the end of the 2020-2021 school year, 80% of our students will recognize at least 20 letters especially those in their own name.

53% Oct

- **Number Recognition** – By the end of the 2020-2021 school year, 80% of our students will recognize the numerals 1-10.

58% Oct



Performance Measure: Financial Performance

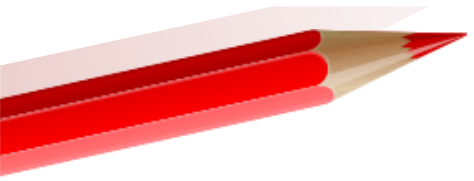

46



15

Performance Measure: Financial Performance

Financial Reporting



Financial Report
submitted within
180 days



Unqualified opinion



Free of Instances of
Material Weaknesses
in Internal Controls



Family & Community Engagement

October			November 05, 2020				December
Sunday	Monday	Tuesday	Wednesday	Thursday	Friday	Saturday	
1 All Saints Day Daylight Savings Dia De Los Muertos	2 Dia De Los Muertos PreK-3: Color, Shape, Size PreK-4: Giants	3 Dia De Los Muertos Election Day 06:00pm Fatherhood Group 06:00pm SMART Parents: At Home Food Gardeni ...	4	5	6	7	
8	9	10 06:00pm Fatherhood Group 06:00pm SMART Parents: At Home Food Gardeni ...	11 PreK-3: Safe and Healthy Me PreK-4: Choices Veterans Day (we are open)	12	13 Caregivers Day	14	
15	16 10:00am Parent Cafe: Holidays	17 06:00pm Fatherhood Group 06:00pm SMART Parents: At Home Food Gardeni ...	18 Progress Reports Thanksgiving Feast for students and ...	19	20	21	
22	23 No PK (but may change)	24 No PK (but may change) 06:00pm Fatherhood Group	25 No PK (but may change)	26 Thanksgiving Break Holiday	27 Thanksgiving Break Holiday	28	
29	30	1	2	3	4	5	

Goal Progress Measure #1

- Parent and Community Meetings
 - Professional Advisory (Oct & Mar)
 - Community Advisory (USI and CoCare wkly)
 - Parent Advisory (Oct & Mar)
 - Area Childcare Providers (SMART Family)
 - Program and Early Childhood Research (Dec)
 - Family Engagement Nights (Wkly events)
 - Academic Areas – Literacy, Math, Science Fair, Development
 - Parenting – Triple P, Parent Café, Incredible Years
 - Social Emotional – Examples: Tantrums, Biting, Sharing, etc.
 - Community Resources -

Goal Progress Measure #2

- Parent Communication of Student Assessment Performance
 - Daily Folders
 - Parent Conferences
 - Phone Calls
 - Texts, and Emails
 - Video Conferencing
 - Development Checklists – Monthly
 - Report Card – 9 weeks



Family & Community Engagement

- Galveston ISD
- United Way
- Teen Health
 - Pediatric Clinic OPEN!
- Ball High School
 - BESST
- UTMB
 - OT, PT, Pediatric Psychiatry
 - Motor/Sensory Lab
- SMART Family Literacy
- Area Childcare Directors
- Galveston Diaper Bank
- Galveston Own Farmer's Market



Teen Health Center, Inc.



United Way of Galveston



USI | URBAN STRATEGIES, INC.
Families at the Center of Results



- Urban Strategies
- Boys and Girls Club
- WorkSource Solutions
- Galveston Urban Ministries
- Family Service Center
- BBVA
- Gulf Breeze
- Galveston Food Bank
- St. Vincent's House
- Ironman
- 3919 Enterprises
- Galveston Children's Museum
- UpBring Head Start
- WIC



Galveston County
FOOD BANK
...because no one should go hungry.

houstonfoodbank Partner



galveston children's museum





In Celebration of Teacher Appreciation Week
the students of 2019-2020 wanted to say...

Facebook

2019-2020



Thank You!

Karin Miller, Executive Director
Antonio Ford, Deputy Executive Director

Action Sheet

MEETING DATE: December 16, 2020

AGENDA ITEM: Financial Reports

The following reports for the period ending 11/30/2020 are attached for your review:

Executive Summary – See Attachment A.

Report No. 1 – FY 2020-21 General Fund revenues, showing budget, actual collections, and (over)/under collected. See Attachment B.

Report No. 2 – FY 2020-21 General Fund expenditures by function, showing budget, encumbrances, expenditures, and unencumbered balances. See Attachment C.

Report No. 3 – Cash and investments for all funds. See Attachment D.

Report No. 4 – Detail of tax collections. See Attachment E.

Report No. 5 – Vendors with aggregated purchases for FY 2020-21 that exceed \$50,000. See Attachment F.

Report No. 6 – Local Vendor Activity for FY 20-21 (zip codes 77550-77554) See Attachment G.

Report No. 7 – Monthly Check Register. See Attachment H.

Report No. 8 – Bond Summary Cover Sheet. See Attachment I.

Report No. 9 - Bond Project Report, showing original bond project cost estimates (PBK) compared to actual bids/expenses. See Attachment J.

RECOMMENDATION: I move that the Board of Trustees receive the financial reports as presented.

Kelli Moulton
Superintendent

Connie Morgenroth

Connie Morgenroth
Asst Superintendent for Business and Operations

Financial Reports – Executive Summary, Board Meeting 12/16/2020

The following reports for 12/16/2020, representing period ending 11/30/2020, are attached for your review:

Report No. 1 – General Fund revenue collected through the period totals \$9,123,577 or 9.9% of projected collections. For the same period in FY 2019-20, revenue totaled \$9,318,057 or 10.7% of budgeted collections. See attachment B.

Report No. 2 – General Fund expenditures through the period total \$15,951,327 or 17.2% of total projected expenditures. For the same period in FY 2019-20, expenditures were \$12,722,918.42 or 14.65% of total expenditures. See attachment C.

Report No. 3 –Cash and investment report. See attachment D.

Funds held by each financial institution are as follows:

Moody Bank	\$7,129,093	
Texas Class Investment Pool	\$13,111,190	N/A (Investment Pool)
Texas Term	\$21,341,610	N/A (Investment Pool)
Total	\$41,581,893	

Report No. 4 – Current ad valorem taxes, delinquent taxes, and penalties & interest collections through the period are as follows (See attachment E).

Fund	Budget	Amount Collected	% Collected
Maintenance & Operations	\$79,650,321	\$7,780,253	9.7%
Interest & Sinking (Debt Payment)	\$8,122,496	\$786,052	9.6%

For the same period in FY 2019-20, collections were \$7,414,362 (10%) for M&O and \$707,887 (10%) for I&S.

Report No. 5 – Vendors with aggregate purchases for FY 2020-21 that exceed \$50,000. See attachment F.

Report No. 6 – Local vendor activity for FY 2020-21 (zip codes 77550-77559). See attachment G.

Report No. 7 - Monthly Check Register. See attachment H.

Report No. 8 – Bond Summary Cover Sheet. See attachment I.

Report No. 9 - Bond Project Report, showing original bond project cost estimates (PBK) compared to actual bids/expenses. See Attachment J.

**GALVESTON ISD
GENERAL FUND REVENUES BY MAJOR OBJECT
AS OF 11-30-2020**

		2020-2021 Revised Budget	Monthly Receipts 11/30/2020	FYTD Receipts 11/30/2020	2020-2021 FYTD (Under)/Over Budget
57--	LOCAL REVENUE	80,736,321	6,774,058	7,997,170	(72,739,151)
58--	STATE REVENUE	10,941,421	291,399	1,098,868	(9,842,553)
59--	FEDERAL REVENUE	875,000	13,883	27,539	(847,461)
79--	OTHER	0	0	0	-
----		92,552,742	7,079,340	9,123,577	(83,429,165)
		% COLLECTED	9.9%		

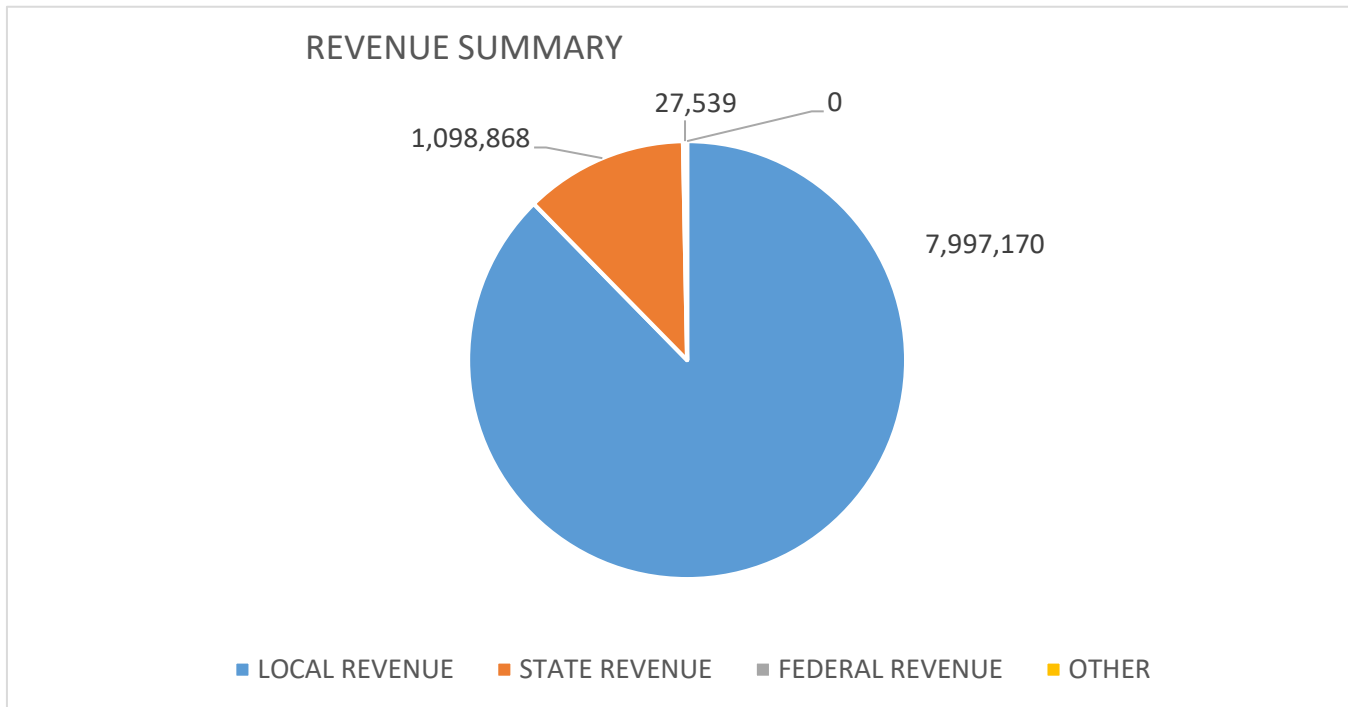

GALVESTON ISD
GENERAL FUND EXPENDITURES BY FUNCTION
AS OF 11/30/2020

Function	Function	Revised Budget November 2020-21	FYTD Activity November 2020-21	Encumbered November 2020-21	Expense + Encumbered	Unencumbered Bal November 2020-21
11	INSTRUCTION	\$ 38,146,603	\$ 9,150,544	\$ 408,766	\$ 9,559,310	\$ (28,587,293)
12	LIBRARY	\$ 363,821	\$ 71,629	\$ 3,796	\$ 75,425	\$ (288,396)
13	TEACHER STAFF DEVELOPMENT	\$ 807,761	\$ 181,051	\$ 15,516	\$ 196,567	\$ (611,194)
21	INSTRUCTIONAL ADMINISTRATION	\$ 1,717,159	\$ 356,506	\$ 7,042	\$ 363,548	\$ (1,353,611)
23	CAMPUS PRINCIPALS	\$ 4,203,350	\$ 984,341	\$ 12,150	\$ 996,491	\$ (3,206,859)
31	COUNSELING	\$ 1,991,893	\$ 435,783	\$ 22,263	\$ 458,046	\$ (1,533,847)
32	SOCIAL WORK	\$ 282,584	\$ 64,258	\$ -	\$ 64,258	\$ (218,326)
33	NURSES	\$ 1,023,271	\$ 201,976	\$ 42,155	\$ 244,131	\$ (779,140)
34	TRANSPORTATION	\$ 3,151,129	\$ 652,671	\$ 61,871	\$ 714,542	\$ (2,436,587)
36	CO/EXTRA CURRICULAR ACTIVITIES	\$ 1,849,557	\$ 417,432	\$ 97,014	\$ 514,446	\$ (1,335,111)
41	GENERAL ADMINISTRATION	\$ 2,754,019	\$ 789,039	\$ 241,658	\$ 1,030,697	\$ (1,723,322)
51	MAINTENANCE	\$ 10,223,553	\$ 1,530,196	\$ 882,182	\$ 2,412,378	\$ (7,811,175)
52	SECURITY	\$ 1,162,392	\$ 305,697	\$ 40,729	\$ 346,426	\$ (815,966)
53	TECHNOLOGY DEPARTMENT	\$ 2,050,293	\$ 517,242	\$ 46,794	\$ 564,036	\$ (1,486,257)
61	COMMUNITY SERVICES	\$ 701,792	\$ 120,695	\$ 354,082	\$ 474,777	\$ (227,015)
81	CONSTRUCTION	\$ -	\$ -	\$ -	\$ -	\$ -
91	CHAPTER 41 RECAPTURE	\$ 21,393,538	\$ -	\$ -	\$ -	\$ (21,393,538)
93	SHARED SERVICES ARRANGMENTS	\$ 60,000	\$ -	\$ -	\$ -	\$ (60,000)
99	APPRAISAL DISTRICT FEES	\$ 689,067	\$ 172,267	\$ 516,800	\$ 689,067	\$ -
		\$ -	\$ -	\$ -	\$ -	\$ -
		\$ -	\$ -	\$ -	\$ -	\$ -
--	COLUMN TOTALS	\$ 92,571,782	\$ 15,951,327	\$ 2,752,818	\$ 18,704,145	\$ (73,867,637)
	EXPENDITURES AS A % OF BUDGET		17.23%		20.21%	

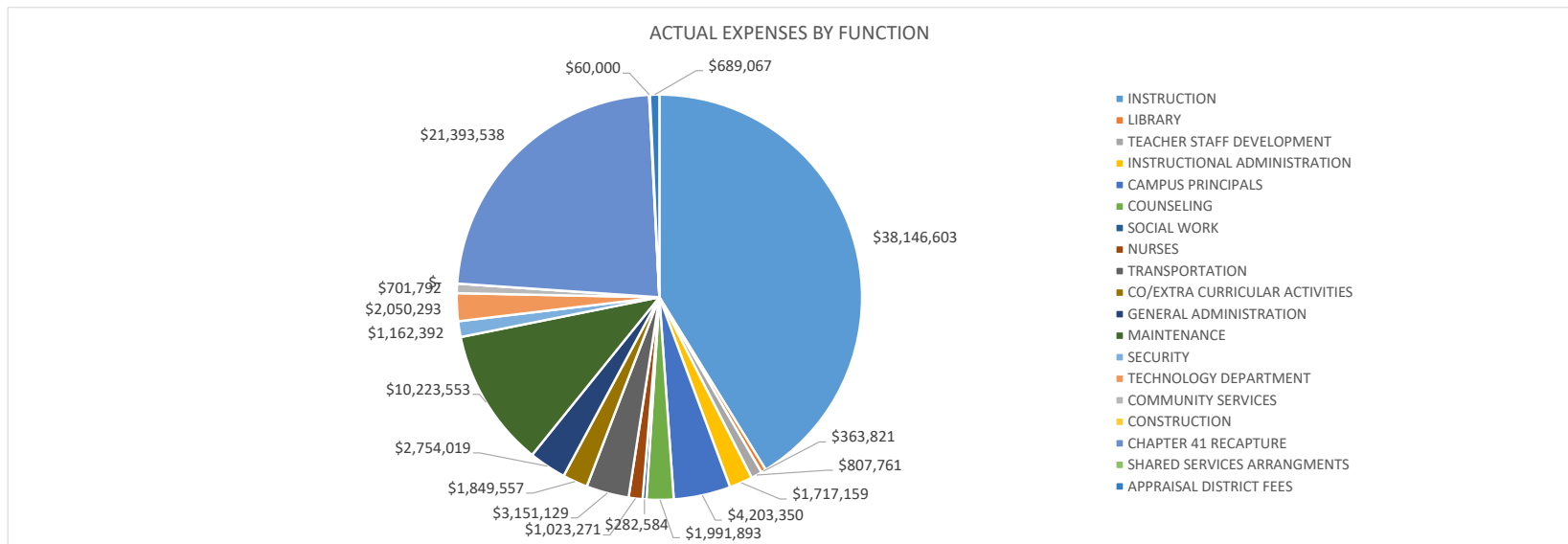

GALVESTON INDEPENDENT SCHOOL DISTRICT
Cash and Investment Report for the Month Ending 11/30/20
For Board Meeting 12/16/20

Depository or Investment Pool	Account Name	Account Number	Type of Account	% Earned	10/31/20 Market Value	Changes to Market Value			11/30/20 Market Value
						Deposits	Withdrawals	ROI (net)	
Moody Bank	General Disbursement	xxxxxx601	Now Account	0.050%	\$ 204,853.01	\$ 11,176,461.65	\$ 7,017,044.10	\$ 116.34	\$ 4,364,386.90
Moody Bank	Activity Fund	xxxxxx627	Now Account	0.050%	\$ 43,556.78	\$ 12,274.05	\$ 14,667.75	\$ 8.97	\$ 41,172.05
Moody Bank	Child Nutrition	xxxxxx619	Now Account	0.050%	\$ 134,759.42	\$ 604,756.82	\$ 144,930.19	\$ 10.37	\$ 594,596.42
Moody Bank	Bond	xxxxxx056	Now Account	0.050%	\$ 88,415.34	\$ 80,000.00	\$ 72,886.01	\$ 3.23	\$ 95,532.56
Moody Bank	Money Market	xxxxxx635	Money Market	1.000%	\$ 2,018,176.37			\$ 1,603.48	\$ 2,019,779.85
Moody Bank	Debt Service	xxxxxx049	Now Account	0.050%	\$ 13,624.94			\$ 0.54	\$ 13,625.48
Total Moody Bank:					\$ 2,503,385.86	\$ 11,873,492.52	\$ 7,249,528.05	\$ 1,742.93	\$ 7,129,093.26
Securities Pledged:									
	Moody Bank (market value)	\$7,000,000							
Texas Class	General Operating	xxxxxxxx01	Investment Pool	0.59%	\$ 8,394,858.29	\$ 7,023,879.94	\$ 6,675,676.98	\$ 851.48	\$ 8,743,912.73
Texas Class	Debt Service	xxxxxxxx02	Investment Pool	0.59%	\$ 2,628,036.12	\$ 677,479.40	\$ -	\$ 356.59	\$ 3,305,872.11
Texas Class	Construction	xxxxxxxx03	Investment Pool	0.59%	\$ 122,283.90	\$ -	\$ 80,000.00	\$ 10.37	\$ 42,294.27
Texas Class	Activity	xxxxxxxx04	Investment Pool	0.59%	\$ 409,020.02		\$ -	\$ 49.80	\$ 409,069.82
Texas Class	Child Nutrition	xxxxxxxx05	Investment Pool	0.59%	\$ 842,685.74		\$ 232,732.58	\$ 88.16	\$ 610,041.32
Total Texas Class:					\$ 12,396,884.07	\$ 7,701,359.34	\$ 6,988,409.56	\$ 1,356.40	\$ 13,111,190.25
Texas TERM DAILY	General Operating	XXXX-02	Investment Pool	0.24%	\$ 19,610,065.52	\$ 73,900.56	\$ 2,500,729.32	\$ 1,597.59	\$ 17,184,834.35
Texas TERM DAILY	Debt Service	XXXX-04	Investment Pool	0.24%	\$ 208,490.55			\$ 17.66	\$ 208,508.21
Texas TERM DAILY	Bond Construction	XXXX-05	Investment Pool	0.24%	\$ 3,140,694.30			\$ 266.06	\$ 3,140,960.36
Texas TERM DAILY	Child Nutrition	XXXX-08	Investment Pool	0.24%	\$ 881,135.06		\$ 73,900.56	\$ 72.71	\$ 807,307.21
Total Texas Class:					\$ 23,840,385.43	\$ 73,900.56	\$ 2,574,629.88	\$ 1,954.02	\$ 21,341,610.13
Total Cash & Investments					\$ 38,740,655.36	\$ 19,648,752.42	\$ 16,812,567.49	\$ 5,053.35	\$ 41,581,893.64

Long-term investments include unrealized gains/losses, so "book value" is estimated value at maturity, as of this report date.

All cash, cash equivalents and other investments are in compliance with the GISD investment policy and also Texas Government Code, Chapter 2256.

Connie Morgenroth, Assistant Superintendent for Business and Operations

GALVESTON ISD
TAX COLLECTIONS BY FUND
AS OF 11/30/2020

FND	FND	OBJ	OBJ	Rev Bud 2020-21	2020-21 FYTD Activity	2020-21 FYTD (UNDER)/Over Budget	NOVEMBER 2020-21 Monthly Activity
199	GENERAL FUND	5711	TAXES-CURRENT YEAR	\$ 77,418,086	\$ 7,078,353	\$ (70,339,733)	\$ 6,505,889
199	GENERAL FUND	5712	TAXES-DELINQUENT	\$ 1,432,235	\$ 556,206	\$ (876,029)	\$ 113,373
199	GENERAL FUND	5719	PENALTY/INT/OTHER TAX REVENUE	\$ 800,000	\$ 145,693	\$ (654,307)	\$ 33,349
							\$ -
FUND TOTAL				\$ 79,650,321	\$ 7,780,252	\$ (71,870,069)	\$ 6,652,611
YTD AS A % OF BUDGET					9.8%		

FND	FND	OBJ	OBJ	Rev Bud 2020-21	2020-21 FYTD Activity	2020-21 FYTD (UNDER)/Over Budget	NOVEMBER 2020-21 Monthly Activity
599	DEBT SERVICE	5711	TAXES-CURRENT YEAR	\$ 7,896,412	\$ 719,241	\$ (7,177,171)	\$ 663,581
599	DEBT SERVICE	5712	TAXES-DELINQUENT	\$ 146,084	\$ 52,922	\$ (93,162)	\$ 10,745
599	DEBT SERVICE	5719	PENALTY/INT/OTHER TAX REVENUE	\$ 80,000	\$ 13,887	\$ (66,113)	\$ 3,152
FUND TOTAL				\$ 8,122,496	\$ 786,050	\$ (7,336,446)	\$ 677,478
YTD AS A % OF BUDGET					9.7%		

ATTACHMENT E

VENDORS OVER \$50,000
Period ending 11-30-2020

Name	Total Payments
AMAZON CAPITAL SERVICES	\$73,806.27
CAVALLO ENERGY TEXAS LLC	\$241,396.18
COMMERCE BANK	\$61,225.47
GLAZIER FOODS COMPANY	\$288,362.06
INSTRUCTURE INC	\$60,382.65
MOODY EARLY CHILDHOOD CENTER	\$187,943.32
HOUGHTON MIFFLIN HARCOURT PUBLISHING CO	\$168,964.25
RICOH USA INC	\$83,488.99
STEVE WEISS MUSIC INC	\$67,959.38
CS ADVANTAGE USAA INCORPORATED	\$389,462.00
SKYWARD, INC	\$150,226.35
CMS COMMUNICATIONS INC	\$269,340.00
RAE SECURITY, INC.	\$114,364.72
ACCELERATE LEARNING INC	\$57,589.55
KICKSTART KIDS	\$65,000.00
CAREHERE LLC	\$113,969.89
TEAL CONSTRUCTION COMPANY	\$132,680.80
GALVESTON COLLEGE	\$259,356.63
PBK ARCHITECTS	\$255,971.98
TASB	\$76,650.35
DELL MARKETING LP	\$84,209.73
DICKINSON ISD	\$117,050.83
CITY OF GALVESTON	\$78,404.74
F.W. WALTON, INC.	\$159,529.80
JR JONES ROOFING	\$456,689.04
GALVESTON CENTRAL APPRAISAL DISTRICT	\$172,266.74
DATAVOX INC	\$62,893.01
CHALLENGE OFFICE PROD INC	\$114,531.50
CFI MECHANICAL, INC.	\$824,143.70
T-MOBILE USA, INC	\$61,035.69
TOTAL	\$5,248,895.62

LOCAL VENDORS
ENDING 11-30-2020

Full Name	Encumbered 2020	Payments 2020	Payments 2020/11	Zip
A B SIGN SHOP	997.57	1,770.40	150.24	77551
A. SMECCA INC	1,036.42	59.34	-	77550
AFFINITY IMMEDIATE CARE PLLC	300.00	225.00	-	77553
ALERT ALARMS	9,630.00	3,210.00	1,070.00	77550
AUTO PLUS	2,119.59	4,243.31	2,093.54	77551
BAY AREA REAL PROPERTY APPRAISERS	-	1,800.00	1,800.00	77550
BREEZEWAY CUSTOM SCREENPRINTIN	2,205.00	8,197.50	890.00	77551
CALLIE WALKER CREATIVE	-	3,850.00	-	77554
CHALMERS HARDWARE	1,676.73	323.27	46.68	77550
CHALMERS HARDWARE & EMBROIDERY	4,190.97	3,062.87	673.61	77550
CITY OF GALVESTON	-	87,215.41	19,678.04	77553
CLASSIC FORD GALVESTON	-	1,326.25	300.24	77553
CLAY CUP STUDIOS	10,450.00	1,050.00	-	77550
COMMUNITIES IN SCHOOLS GALVESTON CO	-	20,000.00	20,000.00	77550
COUNTY OF GALVESTON	17,000.00	1,476.40	-	77553
FASTSIGNS OF GALVESTON	3,654.76	8,389.75	-	77551
FLAMINGO GARDENS INC	-	3,250.00	-	77551
FULLEN CRANE SERVICE	-	440.00	440.00	77551
GALVESTON CHAMBER OF COMMERCE	-	5,740.00	995.00	77550-1501
GALVESTON COLLEGE	324,161.28	300,086.57	-	77550
GALVESTON COUNTY AUDITOR'S OFFICE (-	2,573.60	1,023.95	77553
GALVESTON ISD ADMIN PRINT SHOP	2,500.00	27.18	-	77550
GALVESTON KIWANIS CLUB	-	115.00	-	77552
GALVESTON NEWSPAPERS	2,850.14	1,404.68	750.00	77553
GALVESTON PRINTING, LLC	-	893.26	-	77550
GALVESTON SCHOOL EMPLOYEES FEDERAL	-	141,971.50	-	77551
GALVESTON URBAN MINISTRIES	-	575.15	575.15	77550
GALVESTONS OWN FARMERS MARKET	-	12,500.00	-	77553
GISD CHILD NUTRITION	421.25	2,010.68	-	77550
GISD EDUCATIONAL FOUNDATION	-	7,347.50	2,490.00	77550
GULFSIDE O/H DOOR	-	175.00	-	77551
HICKS CO, W U-HAUL	1,000.00	1,176.87	345.50	77554
IDEAL LUMBER CO	6,342.64	533.66	-	77552-0187
KLEEN JANITORIAL SUPPLY CO	35,273.04	25,934.24	4,047.38	77553
LISTER PLUMBING CO	10,283.50	11,700.80	316.50	77553
MAINLAND FLORAL CO J MAISEL'S	-	372.00	372.00	77550
MANUEL'S TRANSFER	-	600.00	-	77550
MARTY'S CITY AUTO INC	15,000.00	5,017.39	-	77550
MI ABUELITA'S RESTAURANT	-	193.75	-	77551
MISTER GOLF CART LLC	-	1,049.62	-	77550
MOODY EARLY CHILDHOOD CENTER	306,403.93	235,621.32	104,554.82	77550
MOODY GARDEN CONVENTION CENTER AND	-	4,000.00	4,000.00	77554
MOODY GARDENS GOLF COURSE	6,217.95	865.50	-	77554
REPUBLIC PARTS CO	17,856.85	4,377.14	909.18	77550
ROTARY CLUB OF GALVESTON ISLAND	-	98.00	-	77552
SCOTTY'S OVERHEAD DOOR	-	738.00	470.00	77554
SHERWIN-WILLIAMS CO, THE	15,975.69	4,246.01	793.80	77551
STEWART'S PACKAGING INC	500.00	563.21	169.69	77550
SUNFLOWER BAKERY	-	104.67	-	77550
TEEN HEALTH CENTER, INC	406,288.93	29,433.00	-	77553
THE ARTIST BOAT, INC.	-	10,012.20	-	77552
TONY & BROS TOWING & REPAIR	-	600.00	-	77551
TOPGEAR	-	9,570.58	3,009.97	77551
TREASURE ISLAND TROPHIES	-	935.00	935.00	77551
TURTLE ISLAND RESTORATION NETWORK	-	1,520.00	-	77550
UNITED WAY OF GALVESTON INC	-	944.00	303.00	77553
UPWARD HOPE ACADEMY	50,000.00	4,166.66	-	77550
VILLAGE HARDWARE	14,797.46	5,460.73	1,054.38	77551
WEST ISLE URGENT CARE	5,158.00	6,787.00	2,441.00	77551
TOTAL	1,274,291.70	991,930.97	176,698.67	

CHECK REGISTER
DATE ENDING 11-30-2020

VENDOR	CHECK DATE	CHECK NUMBER	INVOICE DESCRIPTION	AMOUNT
DESKINS, MELISSA	11/4/2020	202100018	CONTRACTED SERVICES	1,960.00
TRS ACTIVE CARE	11/4/2020	202000050	OCTOBER PAYMENT	400,482.00
ABC FUNDRAISING	11/5/2020	1826	DISCOUNT CARDS	2,250.00
AMAZON CAPITAL SERVICES	11/5/2020	450504	SEL supplies for: Rosenberg's Chill Zone room La Morgan's Calm Down room CAW 8th grade science calming project	33.99
AMAZON CAPITAL SERVICES	11/5/2020	450504	STUDENT SUPPLIES	313.81
AMAZON CAPITAL SERVICES	11/5/2020	450504	FURNITURE FOR AP'S OFFICE	214.70
AMAZON CAPITAL SERVICES	11/5/2020	450504	PPE Kids/Adults Masks, Faceshields, misc supplies	893.24
AMAZON CAPITAL SERVICES	11/5/2020	450504	CRENSHAW- SUPPLIES FOR TEXAS ACE LIGHTS ON NIGHT	43.89
AMAZON CAPITAL SERVICES	11/5/2020	450504	SEL supplies for: Rosenberg's Chill Zone room La Morgan's Calm Down room CAW 8th grade science calming project	1,993.42
AMAZON CAPITAL SERVICES	11/5/2020	450504	Radio holders	39.30
AMAZON CAPITAL SERVICES	11/5/2020	450504	CLASSROOM SUPPLIES - GT	58.96
AMAZON CAPITAL SERVICES	11/5/2020	450504	OT/PT/ Speech Therapy items	25.99
AMAZON CAPITAL SERVICES	11/5/2020	450504	OT/PT/ Speech Therapy items	239.89
AMAZON CAPITAL SERVICES	11/5/2020	450504	EKG telemonitors for GCC/Moody students of Galveston ISD	1,649.97
AMAZON CAPITAL SERVICES	11/5/2020	450504	SHOP SUPPLIES 2020/2021	135.92
AMAZON CAPITAL SERVICES	11/5/2020	450504	EMPLOYEE OF THE MONTH INCENTIVES	42.43
AMAZON CAPITAL SERVICES	11/5/2020	450504	STUDENT SUPPLIES	4,671.44
AMERICAN EXPRESS	11/5/2020	450505	KELLI MOULTON OCTOBER 2020 CHARGES 9-31073	402.75
AT&T	11/5/2020	450506	CRENSHAW EMERGENCY LINE	50.14
AT&T	11/5/2020	450507	10/23/20 - 11/22/20	10,042.33
AT&T LONG DISTANCE	11/5/2020	450508	BAN SEPT / OCT 2020	10.07
AUTO PLUS	11/5/2020	450509	FOR PURCHASE OF PARTS FLEET VEHICLES & BUSES 2020-2021	65.36
AUTO PLUS	11/5/2020	450509	FOR PURCHASE OF PARTS FLEET VEHICLES & BUSES 2020-2021	31.59
AUTO PLUS	11/5/2020	450509	FOR PURCHASE OF PARTS FLEET VEHICLES & BUSES 2020-2021	152.48
BORDEN DAIRY COMPANY	11/5/2020	389	Milk products	27,047.48
BREEZEWAY CUSTOM SCREENPRINTING	11/5/2020	390	Uniform Shirts for Child Nutrition	890.00
CAREHERE LLC	11/5/2020	450510	2020-21 CAREHERE BLANKET PO- DISTRICT CHARGES	8,424.00
CAVALLO ENERGY TEXAS LLC	11/5/2020	450511	ACCOUNT # 163686 GISD ELECTRIC MULTIPLE ADDRESSES ESI-ID: 32 ACCOUNTS	85,024.74
CDW GOVERNMENT LLC	11/5/2020	450512	Classroom printers for Chase,	82.11

CHECK REGISTER
DATE ENDING 11-30-2020

CDW GOVERNMENT LLC	11/5/2020	450512	Charvoz & Boland Classroom printers for Chase,	209.67
CDW GOVERNMENT LLC	11/5/2020	450512	Charvoz & Boland external USB CD drive for Hospitality Classroom	51.27
CDW GOVERNMENT LLC	11/5/2020	450512	Classroom printers for Chase, Charvoz & Boland	164.22
CERAMIC STORE, INC	11/5/2020	450513	Classroom supplies for Ball High Art (Ceramics)	3,303.45
CFI MECHANICAL, INC.	11/5/2020	450514	Ball - Replace bad valve on condenser water line chiller	2,575.00
CHALK'S TRUCK PARTS INC	11/5/2020	450515	FOR PURCHASE OF PARTS FOR FLEET VEHICLES & BUSES 2020-2021	175.26
CHALLENGE OFFICE PROD INC	11/5/2020	391	Supplies for Child Nutrition	202.38
CHALLENGE OFFICE PROD INC	11/5/2020	450516	GENERAL OFFICE SUPPLIES AND EQUIPMENT 2020/2021 CHOICE PARTNERS 19/025KD-04	2,469.33
CHALLENGE OFFICE PROD INC	11/5/2020	450516	CRENSHAW- UNIT DESIGN BINDERS/SUPPLIES/DIVIDERS/LAPT OP ACCESSORIES	287.58
CHALLENGE OFFICE PROD INC	11/5/2020	450516	OFFICE SUPPLIES FOR BUSINESS OFFICE CHOICE PARTNERS AGREEMENT 19/025KD-04	152.87
CHALLENGE OFFICE PROD INC	11/5/2020	450516	OFFICE SUPPLIES FOR BUSINESS OFFICE CHOICE PARTNERS AGREEMENT 19/025KD-04	249.15
CHALLENGE OFFICE PROD INC	11/5/2020	450516	laserjet print cartridge 410X CHOICE PARTNERS AGREEMENT 19/025KD-04	121.72
CHALLENGE OFFICE PROD INC	11/5/2020	450516	TKP - MORGAN STUDENT SUPPLIES	96.35
CHALLENGE OFFICE PROD INC	11/5/2020	450516	TKP - MORGAN STUDENT SUPPLIES	51.00
CHALLENGE OFFICE PROD INC	11/5/2020	450516	TKP - COLLEGIATE - COMPOSITION NOTEBOOKS	13.80
CHALLENGE OFFICE PROD INC	11/5/2020	450516	White copier paper	670.00
CHALLENGE OFFICE PROD INC	11/5/2020	450516	CLASSROOM SUPPLIES CHOICE PARTNERS 19/025KD-04	273.37
CHALLENGE OFFICE PROD INC	11/5/2020	450516	Challenge - SPECIAL EDUCATION DEPARTMENT 2020-21 CHOICE PARTNERS AGREEMENT 19/025KD-04	19.43
CHALLENGE OFFICE PROD INC	11/5/2020	450516	OFFICE SUPPLIES Choice Partners agreement 19/025KD-04	9.64
CHALLENGE OFFICE PROD INC	11/5/2020	450516	General Supplies & Material Furniture for the Communication/Dispatch Office CHOICE PARTNERS AGREEMENT 19/025KD-04	2,602.22
CHALMERS HARDWARE	11/5/2020	392	Misc. Parts & Supplies - Rene	6.99

CHECK REGISTER
DATE ENDING 11-30-2020

CHALMERS HARDWARE	11/5/2020	392	Alvarado Misc. Parts & Supplies - Rene	16.47
CHALMERS HARDWARE	11/5/2020	392	Alvarado Misc. Parts & Supplies - Rene	18.98
CHALMERS HARDWARE	11/5/2020	392	Alvarado Misc. Parts & Supplies - Rene	4.24
CHALMERS HARDWARE & EMBROIDER	11/5/2020	450517	Alvarado step stools for Ball High	69.98
CHALMERS HARDWARE & EMBROIDER	11/5/2020	450518	Band SUPPLIES FOR 2020-2021 SCHOOL	603.63
CHAMPION TEAMWEAR	11/5/2020	1827	YEAR- OCTOBER 2020-MAY 2021 SPIRIT BAG ROYAL/OSFA ITEM	12.95
CHAMPION TEAMWEAR	11/5/2020	1827	50202AN L E -SERIES JASS SLIP ON	49.20
CHAMPION TEAMWEAR	11/5/2020	1827	BLACK / 6.5 TEES, SHELL, POMPONS, HAIRBOW	113.76
CHAMPION TEAMWEAR	11/5/2020	1827	YTH GROOVE PANT BLACK / MED	72.00
CITY ELECTRIC SUPPLY	11/5/2020	393	GROOVE PANT BLACK / SM Misc Parts & Supplies - Rene	825.00
CITY ELECTRIC SUPPLY	11/5/2020	450519	Alvarado SUPPLIES FOR 2020-2021	458.09
CITY ELECTRIC SUPPLY	11/5/2020	450519	OCTOBER 2020- MAY 2021 SUPPLIES FOR 2020-2021	8.94
CITY ELECTRIC SUPPLY	11/5/2020	450519	OCTOBER 2020- MAY 2021 SUPPLIES FOR 2020-2021	35.90
CITY OF GALVESTON	11/5/2020	450520	OCTOBER 2020- MAY 2021 8/20/20 - 9/21/20 AIM (ALAMO)	954.88
CITY OF GALVESTON	11/5/2020	450520	8/20/20 - 9/28/20 BURNET	3,758.00
CJ CABLING	11/5/2020	450521	OPEN PO FOR NETWORK	292.75
CJ CABLING	11/5/2020	450521	OPEN PO FOR NETWORK	270.00
CJ CABLING	11/5/2020	450521	OPEN PO FOR NETWORK	538.70
CLASSIC FORD GALVESTON	11/5/2020	450522	FOR REPAIRS MADE TO FLEET	192.00
COASTAL DIRECT FLEET SERVICES	11/5/2020	450523	VEHICLES 2020-2021 FOR REPLACEMENT OF TURBINE	308.03
COBURN SUPPLY CO	11/5/2020	450524	SPEED SENSOR TO 2011 INTERNATIONA BUS 2020-2021	61.54
COBURN SUPPLY CO	11/5/2020	450524	SUPPLIES FOR 2020-2021 SCHOOL	69.96
COBURN SUPPLY CO	11/5/2020	450524	YEAR OCTOBER 2020-MAY 2021 SUPPLIES FOR 2020-2021 SCHOOL	164.54
COBURN SUPPLY CO	11/5/2020	450524	YEAR OCTOBER 2020-MAY 2021 SUPPLIES FOR 2020-2021 SCHOOL	56.38
COBURN SUPPLY CO	11/5/2020	450524	YEAR OCTOBER 2020-MAY 2021 SUPPLIES FOR 2020-2021 SCHOOL	136.09
COBURN SUPPLY CO	11/5/2020	450524	YEAR OCTOBER 2020-MAY 2021 SUPPLIES FOR 2020-2021 SCHOOL	881.42
COBURN SUPPLY CO	11/5/2020	450524	YEAR OCTOBER 2020-MAY 2021 SUPPLIES FOR 2020-2021 SCHOOL	51.12

CHECK REGISTER
DATE ENDING 11-30-2020

COBURN SUPPLY CO	11/5/2020	450524	SUPPLIES FOR 2020-2021 SCHOOL YEAR OCTOBER 2020-MAY 2021	47.19
COBURN SUPPLY CO	11/5/2020	450524	SUPPLIES FOR 2020-2021 SCHOOL YEAR OCTOBER 2020-MAY 2021	26.08
COBURN SUPPLY CO	11/5/2020	450524	SUPPLIES FOR 2020-2021 SCHOOL YEAR OCTOBER 2020-MAY 2021	328.20
COBURN SUPPLY CO	11/5/2020	450524	SUPPLIES FOR 2020-2021 SCHOOL YEAR OCTOBER 2020-MAY 2021	19.14
COBURN SUPPLY CO	11/5/2020	450524	SUPPLIES FOR 2020-2021 SCHOOL YEAR OCTOBER 2020-MAY 2021	1,533.59
CONNECTION	11/5/2020	450525	ink for SEL printers	935.49
CRISIS PREVENTION INSTITUTE INC	11/5/2020	450526	CPI Payment for Roshawn Pope invoice	150.00
DANA SAFETY SUPPLY	11/5/2020	450527	Repair & Mint. Vehicles UPDATING Emergency Equipment for 3 OLD Vehicles for the police department INSTALATION: Light Bars Etc. Sales Quote #325399-E	18,582.00
DANA SAFETY SUPPLY	11/5/2020	450527	Repair & Mtn. -Vehicles Updated Graphics on 7 units Quote#356716	6,762.00
DATAVOX INC	11/5/2020	450528	Ball - Dispatch video wall cables	191.92
DATAVOX INC	11/5/2020	450528	Ball - GISD Police - Video Wall Install for Camera Monitoring ; Safety and Security Grant	2,423.09
DATAVOX INC	11/5/2020	450528	Ball - GISD Police - Video Wall Install for Camera Monitoring ; Safety and Security Grant	8,858.73
DELL MARKETING LP	11/5/2020	450529	TKP - MONITOR FOR ERIC MUELLER	295.00
DESIGN SECURITY CONTROLS	11/5/2020	450530	"Open" Purchase Order for Design Security Monthly Monitoring Contracted Services and Repairs	200.00
DRAMATIC PUBLISHING	11/5/2020	450531	Scripts for Collegiate Academy Theater	42.75
ECS LEARNING SYSTEMS, INC	11/5/2020	450532	Writing Books	1,608.71
ENABLING DEVICES	11/5/2020	450533	order for Ann Sound activated switch Wrap around massager	208.90
ENABLING DEVICES	11/5/2020	450533	Ann Moreau Order for Visually Impairment Students SPED Department	93.30
ENTERGY	11/5/2020	450534	9/22/20 - 10/21/20 CRENSHAW	5,795.22
F.W. WALTON, INC.	11/5/2020	86	BOND 2018 ROOF PACKAGE #2 - OPPE Replaces PO#9102000304	64,132.86
FOLLETT SCHOOL SOLUTIONS INC	11/5/2020	450535	OPPE - MAGNET THEME RELATED	102.78

CHECK REGISTER
DATE ENDING 11-30-2020

FOLLETT SCHOOL SOLUTIONS INC	11/5/2020	450535	BOOKS FOR KINDER OPPE - MAGNET THEME RELATED	102.78
FOLLETT SCHOOL SOLUTIONS INC	11/5/2020	450535	BOOKS FOR 1st OPPE - MAGNET THEME RELATED	350.78
FRED PRYOR SEMINARS	11/5/2020	450536	BOOKS FOR 2nd PROJECT MANAGEMENT ONLINE	119.00
FULLEN CRANE SERVICE	11/5/2020	450537	WORKSHOP FOR JAMES RAMIREZ Needed Crane Service for Installing the New Marquee @ Parker	440.00
GALVESTON COUNTY AUDITOR'S OFF	11/5/2020	450538	CAREHERE CLINIC FACILITY / MAINTENANCE COST FOR THE MONTH OF SEPTEMBER 2020	1,023.95
GANDY INK	11/5/2020	1828	TSHIRTS-ATHLETICS VOLLEYBALL	895.00
GLAZIER FOODS COMPANY	11/5/2020	394	Food Products	1,678.56
GLAZIER FOODS COMPANY	11/5/2020	394	Food Products	5,481.29
GLAZIER FOODS COMPANY	11/5/2020	394	Food Products	1,032.45
GLAZIER FOODS COMPANY	11/5/2020	394	Food Products	2,125.82
GLAZIER FOODS COMPANY	11/5/2020	394	Food Products	2,350.40
GLAZIER FOODS COMPANY	11/5/2020	394	Food Products	2,018.86
GLAZIER FOODS COMPANY	11/5/2020	394	Food Products	2,130.14
GLAZIER FOODS COMPANY	11/5/2020	394	Food Products	968.11
GLAZIER FOODS COMPANY	11/5/2020	394	Food Products	2,213.51
GLAZIER FOODS COMPANY	11/5/2020	394	Food Products	3,652.99
GLAZIER FOODS COMPANY	11/5/2020	394	Food Products	2,887.76
GLAZIER FOODS COMPANY	11/5/2020	394	Food Products	3,729.93
GLAZIER FOODS COMPANY	11/5/2020	394	Food Products	(8.65)
GRAINGER	11/5/2020	395	Misc. Parts & Supplies - Rene Alvarado	167.27
GRAINGER	11/5/2020	450539	Needed Cooling Fans for the VFDs & Signs	365.21
GRAINGER	11/5/2020	450539	Needed Cooling Fans for the VFDs & Signs	45.86
GRAINGER	11/5/2020	450539	Needed Pool Pumps, Signs & Dolley Holder	45.86
GRAINGER	11/5/2020	450539	Needed Pool Pumps, Signs & Dolley Holder	3,066.12
HARDIES	11/5/2020	396	Produce Products	54.25
HARDIES	11/5/2020	396	Produce Products	96.69
HARDIES	11/5/2020	396	Produce Products	351.95
HARDIES	11/5/2020	396	Produce Products	244.11
HARDIES	11/5/2020	396	Produce Products	289.45
HARDIES	11/5/2020	396	Produce Products	205.26
HARDIES	11/5/2020	396	Produce Products	925.00
HARDIES	11/5/2020	396	Produce Products	1,308.65
HARDIES	11/5/2020	396	Produce Products	149.11
HARDIES	11/5/2020	396	Produce Products	224.99
HARDIES	11/5/2020	396	Produce Products	91.95
HARDIES	11/5/2020	396	Produce Products	204.70
HARDIES	11/5/2020	396	Produce Products	78.00

CHECK REGISTER
DATE ENDING 11-30-2020

HARDIES	11/5/2020	396	Produce Products	1,323.70
HARRIS COUNTY DEPARTMENT OF ED	11/5/2020	450540	10/1/20 - 10/31/20 STORAGE	1,434.16
HILL, KAREN	11/5/2020	450541	REIMBURSEMENT- TEXAS COUNCIL FOR SOCIAL STUDIES / FALL CONF. OCT. 1-3, 2020--KAREN HILL	170.00
HOME DEPOT	11/5/2020	450542	Open PO for Galveston Ball HS trades, robotics , Fab-Lab and engineering classrooms; to support materials, supplies, and project based learning materials	69.34
HOME DEPOT	11/5/2020	450542	HOME DEPOT CC PURCHASE- 10/7/20 - WALKIE TALKIES FOR TEXAS ACE STAFF- CRENSHAW & OPPE	624.99
HOME DEPOT	11/5/2020	450542	PLEXIGLAS FOR NEW TEACHERS	480.50
HOME DEPOT	11/5/2020	450542	SUPPLIES FOR THE 2020-2021 SCHOOL YEAR-SEPTEMBER/2020	152.52
HOME DEPOT	11/5/2020	450542	SUPPLIES FOR THE 2020-2021 SCHOOL YEAR-OCTOBER 2020-MAY 2021	78.61
HOME DEPOT	11/5/2020	450542	SUPPLIES FOR THE 2020-2021 SCHOOL YEAR-OCTOBER 2020-MAY 2021	50.38
HOME DEPOT	11/5/2020	450542	SUPPLIES FOR THE 2020-2021 SCHOOL YEAR-OCTOBER 2020-MAY 2021	209.75
HOME DEPOT	11/5/2020	450542	SUPPLIES FOR THE 2020-2021 SCHOOL YEAR-OCTOBER 2020-MAY 2021	173.60
HOME DEPOT	11/5/2020	450542	SUPPLIES FOR THE 2020-2021 SCHOOL YEAR-OCTOBER 2020-MAY 2021	154.79
HOME DEPOT	11/5/2020	450542	SUPPLIES FOR THE 2020-2021 SCHOOL YEAR-OCTOBER 2020-MAY 2021	52.64
HOME DEPOT	11/5/2020	450542	SUPPLIES FOR THE 2020-2021 SCHOOL YEAR-OCTOBER 2020-MAY 2021	79.39
HOME DEPOT	11/5/2020	450542	SUPPLIES FOR THE 2020-2021 SCHOOL YEAR-OCTOBER 2020-MAY 2021	44.02
HOME DEPOT	11/5/2020	450542	SUPPLIES FOR THE 2020-2021 SCHOOL YEAR-OCTOBER 2020-MAY 2021	45.81
HOME DEPOT	11/5/2020	450542	SUPPLIES FOR THE 2020-2021 SCHOOL YEAR-OCTOBER 2020-MAY 2021	388.79
HOUGHTON MIFFLIN HARCOURT PUB	11/5/2020	450543	BURNET / 4TH GRADE MATH	799.20

CHECK REGISTER
DATE ENDING 11-30-2020

HOUGHTON MIFFLIN HARCOURT PUB	11/5/2020	450543	DIGITAL INTERVENTION ADDITIONAL MATH RESOURCE CONSUMABLES- SPANISH GO MATH / SCIENCE FUSION BUYBOARD AGREEMENT 573-18 INSTRUCTIONAL MATERIALS, CLASSROOM TEACHING SUPPLIES, & EQUIPMENT	117.00
HOUSE OF RIBBONS	11/5/2020	1829	HALL OF HONOR RIBBONS	398.00
IMAGINE LEARNING INC	11/5/2020	450544	CRENSHAW-IMAGINE LEARNING LICENSES	2,400.00
IMAGINE LEARNING INC	11/5/2020	450544	OPPE-IMAGINE LEARNING LICENSES	5,400.00
IMAGINE LEARNING INC	11/5/2020	450544	MORGAN-IMAGINE LEARNING LICENSES	5,400.00
IMAGINE LEARNING INC	11/5/2020	450544	BURNET-IMAGINE LEARNING LICENSES	4,800.00
INTERSTATE BATTERY SYSTEMS OF HO	11/5/2020	450545	BATTERY REPLACEMENT AND ROTATION 2020-2021	190.00
IXL LEARNING, INC.	11/5/2020	450546	online program for students	1,000.00
KLEEN JANITORIAL SUPPLY CO	11/5/2020	397	Misc. Supplies	25.50
KLEEN JANITORIAL SUPPLY CO	11/5/2020	397	Misc. Supplies	49.00
KLEEN JANITORIAL SUPPLY CO	11/5/2020	397	Misc. Supplies	34.80
KLEEN JANITORIAL SUPPLY CO	11/5/2020	397	Misc. Supplies	229.65
KLEEN JANITORIAL SUPPLY CO	11/5/2020	397	Misc. Supplies	22.42
KLEEN JANITORIAL SUPPLY CO	11/5/2020	397	Misc. Supplies	23.50
KLEEN JANITORIAL SUPPLY CO	11/5/2020	450547	custodial supplies-OCTOBER 2020-MAY 2021	121.50
KLEEN JANITORIAL SUPPLY CO	11/5/2020	450547	custodial supplies-OCTOBER 2020-MAY 2021	69.00
KLEEN JANITORIAL SUPPLY CO	11/5/2020	450547	custodial supplies-OCTOBER 2020-MAY 2021	104.45
KONE, INC	11/5/2020	450548	SERVICES FOR THE 2020-2021 SCHOOL YEAR Per RFCSP#2015-02 OCTOBER 2020-AUGUST 2021	744.00
KROGER-SOUTHWEST	11/5/2020	450549	Kroger-Marshmallows for science experiment	2.38
KROGER-SOUTHWEST	11/5/2020	450549	CLASSROOM SUPPLIES	250.19
KROGER-SOUTHWEST	11/5/2020	450549	CLASSROOM SUPPLIES	(9.64)
KROGER-SOUTHWEST	11/5/2020	450549	OPEN PURCHASE ORDER KROGER: snacks for meetings 10/21 and 10/23 snacks for BHS 10/30	207.19
KROGER-SOUTHWEST	11/5/2020	450549	OPPE- OPEN KROGER PO FOR TEXAS ACE PROGRAM SNACKS AND COOKING CLASS SUPPLIES	53.24
KURZ & CO.	11/5/2020	398	Bread Products	66.42
KURZ & CO.	11/5/2020	398	Bread Products	61.83
KURZ & CO.	11/5/2020	398	Bread Products	116.29
KURZ & CO.	11/5/2020	398	Bread Products	350.46
KURZ & CO.	11/5/2020	398	Bread Products	63.36

CHECK REGISTER
DATE ENDING 11-30-2020

KURZ & CO.	11/5/2020	398	Bread Products	252.12
KURZ & CO.	11/5/2020	398	Bread Products	51.66
KURZ & CO.	11/5/2020	398	Bread Products	51.66
KYRISH TRUCKS OF HOUSTON	11/5/2020	450550	FOP PURCHASE OF PARTS 2020-2021	53.88
KYRISH TRUCKS OF HOUSTON	11/5/2020	450550	FOP PURCHASE OF PARTS 2020-2021	221.37
KYRISH TRUCKS OF HOUSTON	11/5/2020	450550	FOP PURCHASE OF PARTS 2020-2021	109.18
KYRISH TRUCKS OF HOUSTON	11/5/2020	450550	FOP PURCHASE OF PARTS 2020-2021	90.08
KYRISH TRUCKS OF HOUSTON	11/5/2020	450550	FOP PURCHASE OF PARTS 2020-2021	239.46
KYRISH TRUCKS OF HOUSTON	11/5/2020	450550	FOP PURCHASE OF PARTS 2020-2021	165.52
LAKESHORE LEARNING MATERIALS	11/5/2020	450551	Lakeshore Order for Rosenberg / Mignon	901.33
LIQUI-PRO INDUSTRIES INC	11/5/2020	450552	Burnet - Roof Leak Repairs	7,871.74
LIQUI-PRO INDUSTRIES INC	11/5/2020	450552	Ball - Roof Leaks Radio Station	2,550.00
LISTER PLUMBING CO	11/5/2020	450553	District Wide Plumbing Repairs Open Purchase Order November 2020 - August 2021	316.50
MAINLAND FLORAL CO J MAISEL'S	11/5/2020	1830	HOMECOMING COURT FLOWERS	372.00
MATERA PAPER COMPANY	11/5/2020	450554	Covid Supplies - District-Wide Cleaning Supplies	1,003.82
MEDCO	11/5/2020	450555	Training Supplies Medco	707.63
MOODY EARLY CHILDHOOD CENTER	11/5/2020	450556	MECC PAYMENTS FOR BASIC FUNDING ALLOTMENT-FLOW THRU	41,694.25
MUSIC & ARTS CENTER	11/5/2020	450557	Tuba Repairs for Collegiate academy	670.00
MUSIC & ARTS CENTER	11/5/2020	450557	supplies for Ball High Band	111.50
MUSIC & ARTS CENTER	11/5/2020	450557	supplies for Ball High Band	83.77
MUSIC & ARTS CENTER	11/5/2020	450557	Materials for Ball High Band	668.48
MUSIC & ARTS CENTER	11/5/2020	450557	supplies for Ball High Band	111.50
NETRIX LLC	11/5/2020	450558	MICROSOFT INTUNE CLOUD-BASED	7,125.00
NIMCO	11/5/2020	450559	red ribbon week mask	1,236.25
OTC BRANDS INC	11/5/2020	450560	PREK CLASSROOM SUPPLIES	186.29
PARTS TOWN LLC	11/5/2020	399	Misc. Parts & Supplies - Rene Alvarado	358.17
PARTS TOWN LLC	11/5/2020	399	Misc. Parts & Supplies - Rene Alvarado	158.57
PARTS TOWN LLC	11/5/2020	399	Misc. Parts & Supplies - Rene Alvarado	271.56
PERMA-BOUND	11/5/2020	450561	Library Books	2,456.74
PORTIONPAC CHEMICAL CORPORATION	11/5/2020	400	Soap & Chemicals	2,052.85
PROJECT LEAD THE WAY	11/5/2020	450562	PROJECT LEAD THE WAY (PLTW) PARTICIPATION FEES	950.00
PROJECT LEAD THE WAY	11/5/2020	450562	PROJECT LEAD THE WAY (PLTW)	950.00

CHECK REGISTER
DATE ENDING 11-30-2020

PROJECT LEAD THE WAY	11/5/2020	450562	PARTICIPATION FEES PROJECT LEAD THE WAY (PLTW)	950.00
PROJECT LEAD THE WAY	11/5/2020	450562	PARTICIPATION FEES PROJECT LEAD THE WAY (PLTW)	5,400.00
R-B INSTRUMENTS	11/5/2020	450563	R-B Instruments, Inc. -Quote#E1244 - \$50.00	50.00
R-B INSTRUMENTS	11/5/2020	450563	Annual Calibration and Maintenance of Audiometer to standards, performed onsite	50.00
R-B INSTRUMENTS	11/5/2020	450563	ANNUAL CALIBRATION	50.00
R-B INSTRUMENTS	11/5/2020	450563	Annual Calibration and maintenance of Audiometer to Standards/Phyllis Moore/Rosenberg Elementary	50.00
R-B INSTRUMENTS	11/5/2020	450563	ANNUAL CALIBRATION AND MAINTENANCE OF AUDIOMETER FOR BALL HIGH CLINIC	50.00
R-B INSTRUMENTS	11/5/2020	450563	Audiometer Calibration	50.00
R-B INSTRUMENTS	11/5/2020	450563	ANNUAL CALIBRATION AND MAINTENANCE OF AUDIOMETER L.A MORGAN CLINIC	50.00
R-B INSTRUMENTS	11/5/2020	450563	Annual payment for calibration and maintenance of audiometer.	50.00
RAE SECURITY, INC.	11/5/2020	450564	Needed Storrerroom Lever Locksets	3,657.50
RAE SECURITY, INC.	11/5/2020	450564	Needed Cores for Lock Changes	506.00
REGION 4 ESC BUSINESS OFFICE	11/5/2020	450565	Region 4 PD for SAIL Admin., Michelle Hammonds. Leadership Sym.	90.00
REGION 4 ESC BUSINESS OFFICE	11/5/2020	450565	Dyslexia Supplies (Duplicates)	69.36
REPUBLIC PARTS CO	11/5/2020	450566	SUPPLIES FOR 2020-2021 SCHOOL YEAR-OCTOBER 2020-MAY 2021	31.48
REPUBLIC PARTS CO	11/5/2020	450566	SUPPLIES FOR 2020-2021 SCHOOL YEAR-OCTOBER 2020-MAY 2021	7.59
REPUBLIC SERVICES #855	11/5/2020	450567	REPUBLIC SERVICES- OCTOBER 2020 TOTALS	6,771.13
RIVERSIDE INSIGHTS	11/5/2020	450568	Riverside Insights Assessments	498.35
ROBERTS, AMY	11/5/2020	450569	REIMBURSEMENT FOR PAYMENT OF FINGER PRINTS 10/20/2020	49.26
ROBOTICS EDUCATION & COMPETITION	11/5/2020	450570	GALVESTON ISD BHS ROBOTICS TEAM SPACE CITY VRC REGISTRATION	500.00
SAFETY VISION LP	11/5/2020	450571	FOR PURCHASE OF NEW CAMERA SYSTEM FOR BUS#134	2,910.73
SCHOOL HEALTH CORPORATION	11/5/2020	450572	Supplies & Materials	139.72
SCHOOL SPECIALTY	11/5/2020	450573	Order for Ms. Monges (school	81.07

CHECK REGISTER
DATE ENDING 11-30-2020

SCHOOL SPECIALTY	11/5/2020	450573	campus supplies) OUTDOOR DISPLAY FOR FAMILY OUTREACH & COMMUNICATION	133.44
SCHOOL SPECIALTY	11/5/2020	450573	BURNET-MATERIALS FOR UNIT,OUTDOOR CLASSROOM,TEACHER RESOURCE GUIDES	2,352.55
SCOTTY'S OVERHEAD DOOR	11/5/2020	450574	Needed repair of one of the roll down gates @ Ball High	470.00
SHERWIN-WILLIAMS CO, THE	11/5/2020	450575	SUPPLIES FOR SCHOOL YEAR OCTOBER 2020-MAY 2021 Per Region 5 ESC Coop exp	126.18
SHERWIN-WILLIAMS CO, THE	11/5/2020	450575	SUPPLIES FOR SCHOOL YEAR OCTOBER 2020-MAY 2021 Per Region 5 ESC Coop exp	208.47
SHERWIN-WILLIAMS CO, THE	11/5/2020	450575	SUPPLIES FOR SCHOOL YEAR OCTOBER 2020-MAY 2021 Per Region 5 ESC Coop exp	118.37
SHERWIN-WILLIAMS CO, THE	11/5/2020	450575	SUPPLIES FOR SCHOOL YEAR OCTOBER 2020-MAY 2021 Per Region 5 ESC Coop exp	90.05
SOCIAL THINKING	11/5/2020	450576	School Supplies - Zones of Regulation	182.48
STANLEY CONVERGENT SECURITY SO	11/5/2020	450577	"Open" Purchase Order Stanley Security Monthly Monitoring Contracted Services and Repairs	400.50
STANLEY CONVERGENT SECURITY SO	11/5/2020	450577	"Open" Purchase Order Stanley Security Monthly Monitoring Contracted Services and Repairs	540.00
STEWART'S PACKAGING INC	11/5/2020	450578	FOR PURCHASE OF SUPPLIES & MATERIALS 2020-2021	169.69
STUDIES WEEKLY, INC.	11/5/2020	450579	STUDIES WEEKLY - SPANISH -TEXAS COMMUNITY	596.25
TASSP	11/5/2020	450580	Stephanie Mendoza TASSP Invoice #56205 Membership Renewal - TASSP Active (through August 31, 2021)	255.00
THOMAS BUS GULF COAST GP INC	11/5/2020	450581	FOR PURCHASE OF PARTS/LUBE & OIL 2020-2021	214.24
THOMAS BUS GULF COAST GP INC	11/5/2020	450581	FOR PURCHASE OF PARTS/LUBE & OIL 2020-2021	815.37
THOMAS BUS GULF COAST GP INC	11/5/2020	450581	FOR PURCHASE OF PARTS/LUBE & OIL 2020-2021	132.07
TOPGEAR	11/5/2020	1831	STUDENT JACKETS, SHIRTS,	2,471.40

CHECK REGISTER
DATE ENDING 11-30-2020

			POLOS	
TREASURE ISLAND TROPHIES	11/5/2020	1832	Golf Treasure Island Trophies	660.00
UNITED RENTALS	11/5/2020	450582	Needed week long skid steer rental for spreading fall zone material in Crenshaw's Playground.	1,295.02
UTMB AT GALVESTON	11/5/2020	450583	UTMB- PI,DTN,CG Research manager, media lead, CG Design Team Lead, travel, supplies., etc...	19,161.03
VEX ROBOTICS INC	11/5/2020	450584	Items needed for Galveston ISD Ball-Robotics students to build and assemble for competition	260.56
VILLAGE HARDWARE	11/5/2020	401	Misc. Parts & Supplies - Rene Alvarado	5.75
VILLAGE HARDWARE	11/5/2020	450586	FOR PURCHASE OF SUPPLIES & MATERIALS 2020-2021	391.90
VILLAGE HARDWARE	11/5/2020	450585	SUPPLIES Per RFCSP #2018-14 OCTOBER 2020-MAY 2021	656.73
WARD'S NATURAL SCIENCE EST LLC	11/5/2020	450587	Parker K-5 additional PLTW order Quote #8031400088	2,539.18
WARD'S NATURAL SCIENCE EST LLC	11/5/2020	450587	Parker K-5 additional PLTW order Quote #8031400088	1,722.00
WEST ISLE URGENT CARE	11/5/2020	450588	PAYMENT FOR DRUG SCREENING/PHYSICALS/UDS/BAT 2020-2021	1,053.00
WEST ISLE URGENT CARE	11/5/2020	450588	**OPEN PURCHASE ORDER** FOR DRUG SCREENINGS 2020-2021	1,353.00
WEX BANK	11/5/2020	450589	**OPEN PURCHASE ORDER** FOR PAYMENT OF GAS CARD RECEIPTS	35.33
WINFIELD	11/5/2020	450590	District-Wide - Pesticide purchase	2,115.82
BOLIVAR PENINSULA WATER SUPPLY	11/9/2020	20200052	METER READING 10/1/20 - 10/29/20 CRENSHAW	230.40
HSA BANK	11/10/2020	202000038	Payroll accrual	10,820.67
GUAJARDO, MONICA	11/11/2020	202100019	REIMBURSEMENT-"BEAUTIFY THE BUCKET" SUPPLIES	46.61
HUTTON, MARY	11/11/2020	202100020	REIMBURSEMENT "BEAUTIFY THE BUCKET" ARTIST BOAT SUPPLIES	20.30
POPE, GWYNETHIA	11/11/2020	202100021	MILEAGE FOR G. POPE-PURCHASING ACADEMY	253.00
SPENCER, CHERIE	11/11/2020	202100022	EMPLOYEE REIMBURSEMENT	90.85
ALERT ALARMS	11/12/2020	450604	SERVICES FOR 2020-2021-OCTOBER 2020-AUGUST 2021	1,070.00
ALERT SERVICES INC	11/12/2020	450605	Training Supplies Alert Services	434.95
ALERT SERVICES INC	11/12/2020	450605	Training Supplies Alert Services	4,499.95

CHECK REGISTER
DATE ENDING 11-30-2020

ALERT SERVICES INC	11/12/2020	450605	Training Supplies Alert Services	124.95
ALERT SERVICES INC	11/12/2020	450605	Training Supplies Alert Services	4,007.15
AMAZON CAPITAL SERVICES	11/12/2020	450606	SEL supplies for: Rosenberg's Chill Zone room La Morgan's Calm Down room CAW 8th grade science calming project	1,072.86
AMAZON CAPITAL SERVICES	11/12/2020	450606	UTILITY ROAD TRUNK CASE FOR ATHLETICS	499.99
AMAZON CAPITAL SERVICES	11/12/2020	450606	PAPER MATE 9580131 PENS- BETH PARKER	18.03
AMAZON CAPITAL SERVICES	11/12/2020	450606	Amazon order for Flexible lamp for Visually impaired student/Words Flash Cards	165.33
AMAZON CAPITAL SERVICES	11/12/2020	450606	Galveston ISD Ball HS Video Game Design program and UIL Gaming classroom technology upgrades and advancements	499.00
AMAZON CAPITAL SERVICES	11/12/2020	450606	TKP - AUSTIN MS - GARDEN SUPPLIES	511.53
AMAZON CAPITAL SERVICES	11/12/2020	450606	PLASTIC BOX TRUCKS FOR ATHLETICS	1,379.70
AMAZON CAPITAL SERVICES	11/12/2020	450606	SUPPLIES FOR ATHLETIC OFFICE	799.98
AMAZON CAPITAL SERVICES	11/12/2020	450606	Partition Holders	149.95
AMAZON CAPITAL SERVICES	11/12/2020	450606	VINYL GYM TAPE SET OF 6 -ASSORTED COLORS -FLOOR	244.93
AMAZON CAPITAL SERVICES	11/12/2020	450606	The Deepest Well Book-Jessica Maxwell Learning to Breathe 365 Days of Wonder	70.72
AMAZON CAPITAL SERVICES	11/12/2020	450606	Student Supplies SPED	68.20
AMAZON CAPITAL SERVICES	11/12/2020	450606	SUPPLIES FOR BHS CTE SHOP	28.29
AMAZON CAPITAL SERVICES	11/12/2020	450606	Audio book for Hospitality	53.08
AMAZON CAPITAL SERVICES	11/12/2020	450606	BOOKS	95.94
AMAZON CAPITAL SERVICES	11/12/2020	450606	BOOKS	(7.34)
AMAZON CAPITAL SERVICES	11/12/2020	450606	BOOKS	(4.90)
AMAZON CAPITAL SERVICES	11/12/2020	450606	supplies for SEL Student Leadership retreat December 3-4, 2020 Moody Gardens Hotel	1,025.75
AMAZON CAPITAL SERVICES	11/12/2020	1833	CLASSROOM SUPPLIES	69.95
AMAZON CAPITAL SERVICES	11/12/2020	1833	STUCO SUPPLIES - STORAGE AND BATTERIES	102.95
ASHI & 24-7 EMS REMITTANCE	11/12/2020	450607	RENEWAL OF CPR & CHILD CARE CERTIFICATIONS	20.00
AT&T	11/12/2020	450608	10/23/20 - 11/22/20 BALL TEEN HEALTH 409-750-9043 152 4	174.52
AT&T	11/12/2020	450608	10/23/20 - 11/22/20 CHILD NUTRITION 713-A68-6106 098 0	513.31
AT&T	11/12/2020	450608	10/23/20 - 11/22/20 BALL TEEN HEALTH 409-750-9379 153 6	43.63

CHECK REGISTER
DATE ENDING 11-30-2020

AT&T	11/12/2020	450609	LONG DISTANCE CHARGES FOR BURNET 409-740-8951	45.73
AT&T MOBILITY	11/12/2020	450610	9/29/20 - 10/28/20 WIRELESS	447.53
ATHLETIC SUPPLY, INC.	11/12/2020	1834	Athletics-Supplies and Materials- BHS BS ACT	1,580.00
B & H PHOTO VIDEO PRO AUDIO	11/12/2020	450611	GALVESTON BHS CTE-AV CLASSES	475.27
BLACKBOARD INC	11/12/2020	450612	Blackboard Website and content management system software with reliable web hosting 09/01/2020-08/31/2021	15,176.76
BOLIVAR PENINSULA WATER SUPPLY	11/12/2020	450613	10/1/20 - 10/29/20 CRENSHAW SCHOOL	959.00
BXS INSURANCE	11/12/2020	450682	OCTOBER INVOICING	68,759.34
CAREHERE LLC	11/12/2020	450614	2020-21 CAREHERE BLANKET PO-DISTRICT CHARGES	6,306.51
CAREHERE LLC	11/12/2020	450614	2020-21 CAREHERE BLANKET PO-DISTRICT CHARGES	8,006.82
CAREHERE LLC	11/12/2020	450614	2020-21 CAREHERE BLANKET PO-DISTRICT CHARGES	1,258.32
CAREHERE LLC	11/12/2020	450614	2020-21 CAREHERE BLANKET PO-DISTRICT CHARGES	6,493.66
CAREHERE LLC	11/12/2020	450614	2020-21 CAREHERE BLANKET PO-DISTRICT CHARGES	(2,099.87)
CAREHERE LLC	11/12/2020	450614	2020-21 CAREHERE BLANKET PO-DISTRICT CHARGES	7,159.64
CDW GOVERNMENT LLC	11/12/2020	450615	Quote #LSGB515 Canon Ink TIPS agreement 200105	764.43
CDW GOVERNMENT LLC	11/12/2020	450615	warehouse - security Camera mounts	510.44
CHALLENGE OFFICE PROD INC	11/12/2020	450616	GENERAL OFFICE SUPPLIES CHOICE PARTNERS 19/025KD-04	858.15
CHALLENGE OFFICE PROD INC	11/12/2020	450616	OFFICE SUPPLIES CHOICE PARTNERS 19/025KD-04	140.71
CHALLENGE OFFICE PROD INC	11/12/2020	450616	SECURITY TINT ENVELOPE-FINANCE DEPT CHOICE PARTNERS AGREEMENT 19/025KD-04	247.85
CHALLENGE OFFICE PROD INC	11/12/2020	450616	HUMAN CAPITAL MANAGEMENT OFFICE SUPPLIES	450.50
CHALLENGE OFFICE PROD INC	11/12/2020	450616	Challenge: marketing 116 Jackets 116 long sleeve shirts	3,238.75
CHALLENGE OFFICE PROD INC	11/12/2020	450616	Challenge: marketing 116 Jackets 116 long sleeve shirts	1,744.25
CHALLENGE OFFICE PROD INC	11/12/2020	450616	challenge- face masks and Water bottles for Central Middle School CHOICE PARTNERS AGREEMENT 19/025KD-04	1,671.00
CHALLENGE OFFICE PROD INC	11/12/2020	450616	Office Chairs	312.66

CHECK REGISTER
DATE ENDING 11-30-2020

CHALLENGE OFFICE PROD INC	11/12/2020	450616	CLASSROOM SUPPLIES CHOICE PARTNERS 19/025KD-04	12.80
CHALLENGE OFFICE PROD INC	11/12/2020	450616	Challenge order for Business Cards and Envelopes	128.12
CHALLENGE OFFICE PROD INC	11/12/2020	450616	Challenge order for Business Cards and Envelopes	64.00
CHALLENGE OFFICE PROD INC	11/12/2020	450616	CHALLENGE OFFICE	384.64
CHALLENGE OFFICE PROD INC	11/12/2020	450616	CLASSROOM SUPPLIES	170.40
CHALLENGE OFFICE PROD INC	11/12/2020	450616	CLASSROOM SUPPLIES	8.52
CHALLENGE OFFICE PROD INC	11/12/2020	450616	Challenge Order - 96.83	96.83
CHALLENGE OFFICE PROD INC	11/12/2020	450616	Challenge - Brightwell Thomas Southhall CHOICE PARTNERS AGREEMENT 19/025KD-04	1.52
CHALLENGE OFFICE PROD INC	11/12/2020	450616	Challenge - SPECIAL EDUCATION DEPARTMENT 2020-21 CHOICE PARTNERS AGREEMENT 19/025KD-04	14.29
CHALLENGE OFFICE PROD INC	11/12/2020	450616	VARIETY COLORED PAPER FOR LIBRARY USAGE CHOICE PARTNERS AGREEMENT 19/025KD-04	70.44
CHALLENGE OFFICE PROD INC	11/12/2020	450616	CLASSROOM SUPPLIES	22.32
CHALLENGE OFFICE PROD INC	11/12/2020	450616	Paper for school.	912.50
CHALLENGE OFFICE PROD INC	11/12/2020	450616	Campus supplies	139.99
CHALLENGE OFFICE PROD INC	11/12/2020	450616	SUPPLIES CHOICE PARTNERS AGREEMENT 19/025KD-04	44.00
CHALLENGE OFFICE PROD INC	11/12/2020	450616	STOCK PAPER (DIFFERENT COLORS), AND OFFICE SUPPLIES.	407.22
CHALLENGE OFFICE PROD INC	11/12/2020	450616	laserjet print cartridge 410X CHOICE PARTNERS AGREEMENT 19/025KD-04	162.95
CITY ELECTRIC SUPPLY	11/12/2020	450617	SUPPLIES FOR 2020-2021 OCTOBER 2020- MAY 2021	503.79
CITY ELECTRIC SUPPLY	11/12/2020	450617	SUPPLIES FOR 2020-2021 OCTOBER 2020- MAY 2021	159.08
CITY ELECTRIC SUPPLY	11/12/2020	450617	SUPPLIES FOR 2020-2021 OCTOBER 2020- MAY 2021	157.69
CITY ELECTRIC SUPPLY	11/12/2020	450617	SUPPLIES FOR 2020-2021 OCTOBER 2020- MAY 2021	5.35
CITY ELECTRIC SUPPLY	11/12/2020	450617	SUPPLIES FOR 2020-2021 OCTOBER 2020- MAY 2021	31.77
CITY OF GALVESTON	11/12/2020	450618	PARKER	357.76
CITY OF GALVESTON	11/12/2020	450618	8/19/20- 9/18/20 PARKER	1,605.60
CITY OF GALVESTON	11/12/2020	450618	8/196/20 - 9/18/20 PARKER	24.36
CITY OF GALVESTON	11/12/2020	450618	8/20/20 - 9/18/20 SOFTBALL FIELD	184.20
CITY OF GALVESTON	11/12/2020	450618	8/20/20 - 9/18/20 SOFTBALL FIELD SPRINKLER	1,620.16
CITY OF GALVESTON	11/12/2020	450618	8/19/20 - 9/18/20 COLLEGIATE (WEIS)	1,938.53

CHECK REGISTER
DATE ENDING 11-30-2020

CITY OF GALVESTON	11/12/2020	450618	8/19/20 - 9/18/20 COLLEGIATE (WEIS)	24.36
CITY OF GALVESTON	11/12/2020	450618	8/19/20 - 9/18/20 COLLEIGATE (WEIS)	24.36
CITY OF GALVESTON	11/12/2020	450618	8/19/20 - 9/18/20 NEW FIELD	3,244.72
CITY OF GALVESTON	11/12/2020	450618	8/19/20 - 9/18/20 NEW FIELD	336.23
CITY OF GALVESTON	11/12/2020	450618	8/20/20 - 9/18/20 OPPE	343.94
CITY OF GALVESTON	11/12/2020	450618	8/20/20 - 9/28/20 TRANSPORTATION	12.74
CITY OF GALVESTON	11/12/2020	450618	8/20/20 - 9/18/20 TRANSPORTATION	880.48
COBURN SUPPLY CO	11/12/2020	450619	SUPPLIES FOR 2020-2021 SCHOOL YEAR OCTOBER 2020-MAY 2021	127.81
COBURN SUPPLY CO	11/12/2020	450619	SUPPLIES FOR 2020-2021 SCHOOL YEAR OCTOBER 2020-MAY 2021	736.74
COBURN SUPPLY CO	11/12/2020	450619	SUPPLIES FOR 2020-2021 SCHOOL YEAR OCTOBER 2020-MAY 2021	15.99
COBURN SUPPLY CO	11/12/2020	450619	SUPPLIES FOR 2020-2021 SCHOOL YEAR OCTOBER 2020-MAY 2021	26.08
COBURN SUPPLY CO	11/12/2020	450619	SUPPLIES FOR 2020-2021 SCHOOL YEAR OCTOBER 2020-MAY 2021	131.78
COBURN SUPPLY CO	11/12/2020	450619	SUPPLIES FOR 2020-2021 SCHOOL YEAR OCTOBER 2020-MAY 2021	55.06
COBURN SUPPLY CO	11/12/2020	450619	SUPPLIES FOR 2020-2021 SCHOOL YEAR OCTOBER 2020-MAY 2021	55.51
COBURN SUPPLY CO	11/12/2020	450619	SUPPLIES FOR 2020-2021 SCHOOL YEAR OCTOBER 2020-MAY 2021	20.20
COBURN SUPPLY CO	11/12/2020	450619	SUPPLIES FOR 2020-2021 SCHOOL YEAR OCTOBER 2020-MAY 2021	148.00
COBURN SUPPLY CO	11/12/2020	450619	SUPPLIES FOR 2020-2021 SCHOOL YEAR OCTOBER 2020-MAY 2021	35.08
COBURN SUPPLY CO	11/12/2020	450619	SUPPLIES FOR 2020-2021 SCHOOL YEAR OCTOBER 2020-MAY 2021	1,165.93
COMMERCIAL KITCHEN PARTS & SERV	11/12/2020	402	Misc. Parts & Supplies - Rene Alvarado BUYBOARD AGREEMENT 598-19	1,240.25
COMMERCIAL KITCHEN PARTS & SERV	11/12/2020	402	Misc. Parts & Supplies - Rene Alvarado BUYBOARD AGREEMENT 598-19	329.00
COMMUNITIES IN SCHOOLS GALVEST	11/12/2020	450620	Communities in Schools	20,000.00
COP STOP	11/12/2020	450621	UNIFORM/ACCESSORIES Quote#21081	310.00
CRESCENT ELECTRIC	11/12/2020	403	Electrical Work for MECC	1,315.50
DANA SAFETY SUPPLY	11/12/2020	450622	REPAIR & MATN EQUIPMENT	226.50
DATAVOX INC	11/12/2020	450623	Ball - GISD Police - Video Wall Install for Camera Monitoring ; Safety and Security Grant	236.83
DATAVOX INC	11/12/2020	450623	District Wide - Security Camera Server for Exterior	924.83

CHECK REGISTER
DATE ENDING 11-30-2020

DATAVOX INC	11/12/2020	450623	Cameras Ball - GISD Police - Video Wall Install for Camera Monitoring ; Safety and Security Grant	2,076.75
DATAVOX INC	11/12/2020	404	Camera installation and relocation for Child Nutrition	584.48
DELL MARKETING LP	11/12/2020	450624	Warehouse - Facilities Department Chrome Books for Maintenance Department	3,959.76
DELL MARKETING LP	11/12/2020	450624	TKP - COMPUTER FOR L. HANEY	1,690.00
DEMCO, INC	11/12/2020	450625	Laminating film	98.90
ELECTUDE USA LLC	11/12/2020	450626	20-21 Galveston Ball Automotive Annual Renewal AE High School User License	1,900.00
FOLLETT SCHOOL SOLUTIONS INC	11/12/2020	450627	OPPE - MAGNET THEME RELATED BOOKS FOR 3rd	98.76
GALVESTON CENTRAL APPRAISAL DIS	11/12/2020	450628	OPEN PO FOR GALVESTON CENTRAL APPRAISAL DISTRICT 20-21	172,266.74
GALVESTON CHAMBER OF COMMERCE	11/12/2020	450629	2021 Leadership Galveston (Bobby Temple) Invoice 999936866 Galveston Regional Chamber of Commerce 2228 Mechanic Street, Suite 101 Galveston, TX 77550 (409) 763-5326 fax: (409) 763- 8271 gcc@galvestonchamber.com	995.00
GALVESTON NEWSPAPERS	11/12/2020	450630	Galveston Daily News	550.00
GALVESTON NEWSPAPERS	11/12/2020	450630	Galveston Daily News	200.00
GALVESTON TRANSFER STATION TEXA	11/12/2020	450631	trash disposal OCTOBER 2020-MAY 2021	166.40
GALVESTON URBAN MINISTRIES	11/12/2020	1835	Check Request-Galveston Urban Ministries-Red Ribbon Week Free Dress Fundraiser	575.15
GANDY INK	11/12/2020	450632	GANDY INK- - QUOTE#695693 - \$895.00	895.00
GLAZIER FOODS COMPANY	11/12/2020	405	Food Products	2,930.51
GLAZIER FOODS COMPANY	11/12/2020	405	Food Products	1,591.02
GLAZIER FOODS COMPANY	11/12/2020	405	Food Products	2,784.44
GLAZIER FOODS COMPANY	11/12/2020	405	Food Products	1,752.00
GLAZIER FOODS COMPANY	11/12/2020	405	Food Products	3,265.76
GLAZIER FOODS COMPANY	11/12/2020	405	Food Products	3,633.91
GLAZIER FOODS COMPANY	11/12/2020	405	Food Products	3,545.51
GLAZIER FOODS COMPANY	11/12/2020	405	Food Products	978.60
GLAZIER FOODS COMPANY	11/12/2020	405	Food Products	826.61
GLAZIER FOODS COMPANY	11/12/2020	405	Food Products	2,396.66
GLAZIER FOODS COMPANY	11/12/2020	405	Food Products	23.88
GLAZIER FOODS COMPANY	11/12/2020	405	Food Products	3,688.32
GLAZIER FOODS COMPANY	11/12/2020	405	Food Products	658.16

CHECK REGISTER
DATE ENDING 11-30-2020

GOMEZ, VICTOR	11/12/2020	450633	GC Welding Instructor working after hours to have students make up hours lost during quarantine Spring 2020	2,580.00
GRAMMARLY, INC.	11/12/2020	450634	SUBSCRIPTION-Good Grammar is Just the Beginning Quote No: OH391122020	2,300.00
HARDIES	11/12/2020	406	Produce Products	218.60
HARDIES	11/12/2020	406	Produce Products	253.55
HARDIES	11/12/2020	406	Produce Products	137.13
HARDIES	11/12/2020	406	Produce Products	319.50
HARDIES	11/12/2020	406	Produce Products	(25.50)
HARDIES	11/12/2020	406	Produce Products	284.25
HARDIES	11/12/2020	406	Produce Products	243.50
HARDIES	11/12/2020	406	Produce Products	180.95
HARDIES	11/12/2020	406	Produce Products	88.00
HARDIES	11/12/2020	406	Produce Products	176.00
HARDIES	11/12/2020	406	Produce Products	22.00
HARDIES	11/12/2020	406	Produce Products	88.00
HARDIES	11/12/2020	406	Produce Products	64.18
HARDIES	11/12/2020	406	Produce Products	44.00
HARDIES	11/12/2020	406	Produce Products	(44.00)
HARDIES	11/12/2020	406	Produce Products	44.00
HARDIES	11/12/2020	406	Produce Products	44.00
HARDIES	11/12/2020	406	Produce Products	22.00
HARDIES	11/12/2020	406	Produce Products	100.30
HARDIES	11/12/2020	406	Produce Products	102.75
HARDIES	11/12/2020	406	Produce Products	68.80
HARDIES	11/12/2020	406	Produce Products	44.00
HARDIES	11/12/2020	406	Produce Products	44.00
HOME DEPOT	11/12/2020	450635	Open PO for Galveston Ball HS trades, robotics , Fab-Lab and engineering classrooms; to support materials, supplies, and project based learning materials	14.97
HOME DEPOT	11/12/2020	450635	Open PO for Galveston Ball HS trades, robotics , Fab-Lab and engineering classrooms; to support materials, supplies, and project based learning materials	348.00
HOME DEPOT	11/12/2020	450635	SUPPLIES FOR THE 2020-2021 SCHOOL YEAR-OCTOBER 2020-MAY 2021	35.08
HOME DEPOT	11/12/2020	450635	SUPPLIES FOR THE 2020-2021 SCHOOL YEAR-OCTOBER 2020-MAY 2021	66.84
HOME DEPOT	11/12/2020	450635	SUPPLIES FOR THE 2020-2021 SCHOOL YEAR-OCTOBER 2020-MAY 2021	19.25

CHECK REGISTER
DATE ENDING 11-30-2020

HOME DEPOT	11/12/2020	450635	SUPPLIES FOR THE 2020-2021 SCHOOL YEAR-OCTOBER 2020-MAY	2021	200.82
HOME DEPOT	11/12/2020	450635	SUPPLIES FOR THE 2020-2021 SCHOOL YEAR-OCTOBER 2020-MAY	2021	19.43
HOME DEPOT	11/12/2020	450635	SUPPLIES FOR THE 2020-2021 SCHOOL YEAR-OCTOBER 2020-MAY	2021	178.73
HOME DEPOT	11/12/2020	450635	SUPPLIES FOR THE 2020-2021 SCHOOL YEAR-OCTOBER 2020-MAY	2021	4.66
HOME DEPOT	11/12/2020	450635	SUPPLIES FOR THE 2020-2021 SCHOOL YEAR-OCTOBER 2020-MAY	2021	256.43
HOME DEPOT	11/12/2020	450635	SUPPLIES FOR THE 2020-2021 SCHOOL YEAR-OCTOBER 2020-MAY	2021	156.86
HOME DEPOT	11/12/2020	450635	SUPPLIES FOR THE 2020-2021 SCHOOL YEAR-OCTOBER 2020-MAY	2021	332.62
HOME DEPOT	11/12/2020	450635	SUPPLIES FOR THE 2020-2021 SCHOOL YEAR-OCTOBER 2020-MAY	2021	118.86
HOME DEPOT	11/12/2020	450635	SUPPLIES FOR THE 2020-2021 SCHOOL YEAR-OCTOBER 2020-MAY	2021	135.26
HOME DEPOT	11/12/2020	450635	SUPPLIES FOR THE 2020-2021 SCHOOL YEAR-OCTOBER 2020-MAY	2021	29.20
HOME DEPOT	11/12/2020	450635	SUPPLIES FOR THE 2020-2021 SCHOOL YEAR-OCTOBER 2020-MAY	2021	55.58
IMCAT	11/12/2020	450636	IMCAT REGISTRATION (INSTRUCTIONAL MATERIALS COORD. ASSOC. OF TX) VIRTUAL CONF. DEC. 15 & 16	2021	295.00
IMCAT	11/12/2020	450636	IMCAT REGISTRATION (INSTRUCTIONAL MATERIALS COORD. ASSOC. OF TX) VIRTUAL CONF. DEC. 15 & 16	2021	295.00
IMCAT	11/12/2020	450636	IMCAT REGISTRATION (INSTRUCTIONAL MATERIALS COORD. ASSOC. OF TX) VIRTUAL CONF. DEC. 15 & 16	2021	295.00
INFECTION CONTROLS, INC.	11/12/2020	450637	District Wide - Illness and Infection Prevention Program - Annual Contract		39,830.29
ISLAND EVALUATION AND PROFESSIONAL	11/12/2020	450638	Island Evaluation and		1,050.00

CHECK REGISTER
DATE ENDING 11-30-2020

			Professional Services Melissa L. Knop, Ph.D.	
ISLAND EVALUATION AND PROFESSIONAL SERVICES	11/12/2020	450638	Invoice from Melissa Knop Island Evaluation and Professional Services	1,400.00
ISLAND FIRE & SAFETY CO, INC	11/12/2020	450639	FIRE SAFETY FOR VARIOUS CAMPUS FOR OCTOBER 2020-MAY 2021	318.31
ISLAND FIRE & SAFETY CO, INC	11/12/2020	450639	FIRE SAFETY FOR VARIOUS CAMPUS FOR OCTOBER 2020-MAY 2021	180.00
ISLAND FIRE & SAFETY CO, INC	11/12/2020	450639	FIRE SAFETY FOR VARIOUS CAMPUS FOR OCTOBER 2020-MAY 2021	241.02
ISLAND FIRE & SAFETY CO, INC	11/12/2020	450639	Central - Gym Beam Detectors	2,614.10
JOSTENS, INC	11/12/2020	1836	Jostens, Inc. Yearbook down payment	2,386.21
KLEEN JANITORIAL SUPPLY CO	11/12/2020	407	Misc. Supplies	49.00
KLEEN JANITORIAL SUPPLY CO	11/12/2020	407	Misc. Supplies	25.50
KLEEN JANITORIAL SUPPLY CO	11/12/2020	407	Misc. Supplies	189.60
KLEEN JANITORIAL SUPPLY CO	11/12/2020	407	Misc. Supplies	38.49
KLEEN JANITORIAL SUPPLY CO	11/12/2020	450640	custodial supplies-OCTOBER 2020-MAY 2021	42.90
KLEEN JANITORIAL SUPPLY CO	11/12/2020	450640	custodial supplies-OCTOBER 2020-MAY 2021	359.60
KLEEN JANITORIAL SUPPLY CO	11/12/2020	450640	custodial supplies-OCTOBER 2020-MAY 2021	269.70
KLEEN JANITORIAL SUPPLY CO	11/12/2020	450640	custodial supplies-OCTOBER 2020-MAY 2021	370.65
KLEEN JANITORIAL SUPPLY CO	11/12/2020	450640	custodial supplies-OCTOBER 2020-MAY 2021	89.90
KLEEN JANITORIAL SUPPLY CO	11/12/2020	450640	custodial supplies-OCTOBER 2020-MAY 2021	179.80
KLEEN JANITORIAL SUPPLY CO	11/12/2020	450640	custodial supplies-OCTOBER 2020-MAY 2021	269.70
KLEEN JANITORIAL SUPPLY CO	11/12/2020	450640	custodial supplies-OCTOBER 2020-MAY 2021	353.70
KLEEN JANITORIAL SUPPLY CO	11/12/2020	450640	custodial supplies-OCTOBER 2020-MAY 2021	516.55
KLEEN JANITORIAL SUPPLY CO	11/12/2020	450640	custodial supplies-OCTOBER 2020-MAY 2021	89.90
KLEEN JANITORIAL SUPPLY CO	11/12/2020	450640	custodial supplies-OCTOBER 2020-MAY 2021	218.85
KONE, INC	11/12/2020	450641	SERVICES FOR THE 2020-2021 SCHOOL YEAR Per RFCSP#2015-02 OCTOBER 2020-AUGUST 2021	248.00
KONE, INC	11/12/2020	450641	SERVICES FOR THE 2020-2021 SCHOOL YEAR Per RFCSP#2015-02 OCTOBER 2020-AUGUST 2021	248.00
KROGER-SOUTHWEST	11/12/2020	450642	Kroger Receipt - Items for	28.73

CHECK REGISTER
DATE ENDING 11-30-2020

KROGER-SOUTHWEST	11/12/2020	450642	Karina Cabriales FOR PURCHAS OF DRINKS FOR TRANSPORTATION DEPT 2020-2021	103.72
KROGER-SOUTHWEST	11/12/2020	450642	DISTRICT- OPEN KROGER PO FOR TEXAS ACE PROGRAM SNACKS AND COOKING CLASS SUPPLIES	38.85
KROGER-SOUTHWEST	11/12/2020	450642	DISTRICT- OPEN KROGER PO FOR TEXAS ACE PROGRAM SNACKS AND COOKING CLASS SUPPLIES	38.59
KROGER-SOUTHWEST	11/12/2020	450642	CRENSHAW- OPEN KROGER PO FOR TEXAS ACE PROGRAM SNACKS AND COOKING CLASS SUPPLIES	39.34
KROGER-SOUTHWEST	11/12/2020	450642	SUPPLIES FOR MEETINGS	11.36
KROGER-SOUTHWEST	11/12/2020	450642	TEACHER BREAK ROOM SUPPLIES-CLCS	51.43
KURZ & CO.	11/12/2020	408	Bread Products	51.66
KURZ & CO.	11/12/2020	408	Bread Products	110.70
KURZ & CO.	11/12/2020	408	Bread Products	101.02
KURZ & CO.	11/12/2020	408	Bread Products	51.66
KURZ & CO.	11/12/2020	408	Bread Products	89.57
KURZ & CO.	11/12/2020	408	Bread Products	83.08
KURZ & CO.	11/12/2020	408	Bread Products	51.66
LAKESHORE LEARNING MATERIALS	11/12/2020	450643	PARKER- MATERIALS FOR 3RD GRADE- MATH MANIPULATIVES	692.39
LEEDERSHIP PLUS-HERMAN LEE	11/12/2020	450644	COLLEGIATE- CONSULTANT SERVICES	2,128.00
MATERA PAPER COMPANY	11/12/2020	450646	SUPPLIES NEEDED FOR VARIOUS SCHOOLS FOR THE 2020-2021 for Month of OCTOBER 2020-MAY	56.55
MEDCO	11/12/2020	450647	Training Supplies Medco	6.60
MICRO INTEGRATION	11/12/2020	450648	CALL MANAGER IP PHONE LICENSE	1,264.40
MOODY EARLY CHILDHOOD CENTER	11/12/2020	450649	MECC PAYMENTS FOR BASIC FUNDING ALLOTMENT-FLOW THRU	44,909.32
MUSIC & ARTS CENTER	11/12/2020	450650	repairs for Ball High Band	1,310.00
NCS PEARSON, INC.	11/12/2020	450651	Pearson Testing Assessments - NEPSY, BASC, CDI, KTEA, WISC, ASRS	2,313.93
O'REILLY AUTO PARTS	11/12/2020	450652	Galveston Ball HS open PO to O' Reilly's for Ball HS automotive program	24.98
O'REILLY AUTO PARTS	11/12/2020	450652	Galveston Ball HS open PO to O' Reilly's for Ball HS automotive program	74.91
O'REILLY AUTO PARTS	11/12/2020	450652	Galveston Ball HS open PO to O' Reilly's for Ball HS automotive program	35.96
O'REILLY AUTO PARTS	11/12/2020	450652	Galveston Ball HS open PO to O' Reilly's for Ball HS automotive program	58.10

CHECK REGISTER
DATE ENDING 11-30-2020

O'REILLY AUTO PARTS	11/12/2020	450652	Galveston Ball HS open PO to O' Reilly's for Ball HS automotive program	8.91
OTC BRANDS INC	11/12/2020	1837	INCENTIVES AND SUPPLIES	116.14
PARTS TOWN LLC	11/12/2020	409	Misc. Parts & Supplies - Rene Alvarado	1,186.09
PBK ARCHITECTS	11/12/2020	87	NEW GYM @ PARKER ES/SUPPORT FACILITY RENOVATIONS REIMBURSABLE	800.00
PBK ARCHITECTS	11/12/2020	87	Bond 2018 - PBK - ARCHITECTURAL SERVICES - Roof Project 3 Rosenberg Roof & Envelope Repairs at Rosenberg ES; PBK Project # 18266R	846.61
PBK ARCHITECTS	11/12/2020	87	Bond 2018 - PBK - ARCHITECTURAL SERVICES - Roof Project 1 Ball Central Austin ; PBK Project # 18264R	495.29
PERMA-BOUND	11/12/2020	450653	PARKER - LIBRARY BOOKS	3,947.52
PERMA-BOUND	11/12/2020	450653	Library Books	1,417.43
PIONEER MANUFACTURING COMPAN	11/12/2020	450654	Needed White Striping Paint for the Athletic Fields	1,297.50
PROFITT, MICHELLE	11/12/2020	450655	REIMBURSEMENT FOR GIRLS ATHLETICS	106.00
PROJECT LEAD THE WAY	11/12/2020	450656	2020-2021 GCC PLTW ENGINEERING 9-12 O'CONNELL	3,049.10
R&R GAS AND EQUIPMENT, INC	11/12/2020	450657	Safety items needed for GCC Welding/Electrical/Engineering students tours	416.68
R&R GAS AND EQUIPMENT, INC	11/12/2020	450657	OPEN request for Galveston ISD Ball HS welding cylinders and gases rental for the 2020-2021 school year	443.30
R-B INSTRUMENTS	11/12/2020	450658	Annual Calibration and Maintenance of Audiometer	50.00
R-B INSTRUMENTS	11/12/2020	450658	CLINIC-AUDIOMETER	62.00
R-B INSTRUMENTS	11/12/2020	450658	CLINIC - AUDIOMENTERS 2020-2021	50.00
RAE SECURITY, INC.	11/12/2020	450659	Needed Storeroom Mortise Locks	4,986.00
REGION 4 ESC BUSINESS OFFICE	11/12/2020	450660	REGISTRATION / REGION 4 -SESSION # 1570971-RESULTS DRIVEN ACCOUNTABILITY (RDA)	150.00
REGION 4 ESC BUSINESS OFFICE	11/12/2020	450660	REGISTRATION - SESSION 1566468 /COMPARABILITY TITLE I -VIRTUAL TRAINING NOV. 3,	35.00
REGION 4 ESC BUSINESS OFFICE	11/12/2020	450660	Region 4 RDA Registration for Galveston ISD: Eric Paul	75.00
RENAISSANCE	11/12/2020	450661	RENAISSANCE STAR MATH	990.00

2020

CHECK REGISTER
DATE ENDING 11-30-2020

			SUBSCRIPTIONS	
REPUBLIC PARTS CO	11/12/2020	450662	SUPPLIES FOR 2020-2021 SCHOOL YEAR-OCTOBER 2020-MAY 2021	33.46
REPUBLIC PARTS CO	11/12/2020	450662	SUPPLIES FOR 2020-2021 SCHOOL YEAR-OCTOBER 2020-MAY 2021	6.58
REPUBLIC PARTS CO	11/12/2020	450662	SUPPLIES FOR 2020-2021 SCHOOL YEAR-OCTOBER 2020-MAY 2021	214.77
REPUBLIC PARTS CO	11/12/2020	450662	SUPPLIES FOR 2020-2021 SCHOOL YEAR-OCTOBER 2020-MAY 2021	7.66
REPUBLIC PARTS CO	11/12/2020	450662	SUPPLIES FOR 2020-2021 SCHOOL YEAR-OCTOBER 2020-MAY 2021	16.48
REPUBLIC PARTS CO	11/12/2020	450662	SUPPLIES FOR 2020-2021 SCHOOL YEAR-OCTOBER 2020-MAY 2021	64.11
RICOH USA INC	11/12/2020	450663	open purchase order for maintenance on copiers 2020-21	6,422.23
RJ COOPER & ASSOCIATES, INC.	11/12/2020	450664	Visual Impairment Technology	346.00
ROBOSOURCE, LLC	11/12/2020	450665	Items needed for Galveston ISD Ball-Robotics students to build and assemble for competition	83.72
SAFETY VISION LP	11/12/2020	450666	FOR PURCHASE OF NEW CAMERA SYSTEM FOR BUS#106	2,910.73
SCHOOL SPECIALTY	11/12/2020	450667	Order for teacher (campus supplies) (Bailon)	85.65
SKYWARD, INC	11/12/2020	450668	SKYWARD ANNUAL LICENSE RENEWAL - FEES FOR YEAR 2020-2021	144,843.35
SOUTHERN TIRE MART	11/12/2020	450669	FOR PURCHASE OF WHEELS & RIMS FOR BUSES AND FLEET VEHICLES 2020-2021	610.00
SPARKLETTS	11/12/2020	450671	Open PO for Sparkletts Water	39.74
SPARKLETTS	11/12/2020	450672	**OPEN PURCHASE ORDER** MONTHLY WATER SERVICE FOR TKP OFFICE	35.57
SPARKLETTS	11/12/2020	450673	**OPEN PURCHASE ORDER** MONTHLY WATER SERVICE FOR TKP OFFICE	27.08
SPARKLETTS	11/12/2020	450670	**Open Purchase Order** Monthly water service for Business Office	62.56
TASA TEXAS ASSO OF SCHOOL ADM	11/12/2020	450674	Professional Organization Memberships required to maintain knowledge of position, gain innovative ideas/needs to bring to GISD, etc.	660.00
TERMINIX PROCESING CENTER	11/12/2020	450675	PEST CONTROL TREATMENT-OCTOBER 2020-AUGUST 2021	1,810.00

CHECK REGISTER
DATE ENDING 11-30-2020

TEXAS CITY FEED & SUPPLY	11/12/2020	450676	"Open P.O. Supplies Food for K-9 POLICE DOG	45.99
TEXAS GAS SERVICE	11/12/2020	450677	9/30/20 - 10/29/20 ROSENBERG	124.07
TEXAS GAS SERVICE	11/12/2020	450677	10/1/20 - 10/30/20 MORGAN	143.01
TEXAS GAS SERVICE	11/12/2020	450677	10/1/20 - 10/30/20 MECC	112.75
TEXAS GAS SERVICE	11/12/2020	450677	9/30/20 - 10/29/20 CENTRAL	1,045.33
TEXAS GAS SERVICE	11/12/2020	450677	10/1/20 - 10/30/20 SF AUSTIN	58.80
TEXAS GAS SERVICE	11/12/2020	450677	10/1/20 - 10/30/20 BALL HIGH	121.61
TOPGEAR	11/12/2020	1838	REPEAT ADDITIONAL SHIRTS FOR BAND STUDENTS	193.75
TREASURE ISLAND TROPHIES	11/12/2020	450678	Annual Ball High BESTT wall plate	25.00
WATER TREATMENT SERVICES INC	11/12/2020	450679	MONTHLY SERVICE FOR 2020-2021 YEAR-OCTOBER 2020-AUGUST 2021 PAUL BYERS	2,896.00
WEXFORD INC	11/12/2020	450680	SEL EVALUATION SERVICES	10,000.00
WORTHINGTON DIRECT HOLDINGS IN	11/12/2020	450681	CRENSHAW-STEM LAB FURNITURE	8,059.74
A B SIGN SHOP	11/19/2020	1839	BAND BANNER FOR PARADES	150.24
AMAZON CAPITAL SERVICES	11/19/2020	450684	TEACHER SUPPLIES	347.87
AMAZON CAPITAL SERVICES	11/19/2020	450684	BOOKS	57.24
AMAZON CAPITAL SERVICES	11/19/2020	450684	COVID - SUPPLIES	569.33
AMAZON CAPITAL SERVICES	11/19/2020	450684	Step Stool for Kids (2 Pack), Toddlers Stool for Potty Training,	413.53
AMAZON CAPITAL SERVICES	11/19/2020	450684	SUPPLIES- MORGAN	479.70
AMAZON CAPITAL SERVICES	11/19/2020	450684	TKP/MORGAN STERILITE TOTES	543.92
AMAZON CAPITAL SERVICES	11/19/2020	450684	BAND SUPPLIES	322.92
AMAZON CAPITAL SERVICES	11/19/2020	450684	BAND SUPPLIES	(9.60)
AMAZON CAPITAL SERVICES	11/19/2020	450684	BAND SUPPLIES	(9.59)
AMAZON CAPITAL SERVICES	11/19/2020	450684	BAND SUPPLIES	(9.59)
AMAZON CAPITAL SERVICES	11/19/2020	450684	BAND SUPPLIES	(9.59)
AMAZON CAPITAL SERVICES	11/19/2020	450684	GENERAL SUPPLIES AND EQUIPMENT 2020/2021 SCHOOL YEAR	406.19
AMAZON CAPITAL SERVICES	11/19/2020	450684	supplies for SEL Student Leadership retreat December 3-4, 2020 Moody Gardens Hotel	628.21
AMAZON CAPITAL SERVICES	11/19/2020	450684	TKP COLLEGIATE BOOKS	95.85
AMAZON CAPITAL SERVICES	11/19/2020	450684	SUPPLIES	239.85
AMAZON CAPITAL SERVICES	11/19/2020	450684	KINDERGARTEN (MS. MARKELLO CLASSROOM SUPPLIES FOR STUDENTS AND TEACHER)	199.26
AMAZON CAPITAL SERVICES	11/19/2020	450684	TKP/MORGAN STERILITE TOTES	1,767.74
AMAZON CAPITAL SERVICES	11/19/2020	450684	AT Supplies for OT/PT/Visual	5,153.44
AMAZON CAPITAL SERVICES	11/19/2020	450684	Sand Timers/Rosenberg Elementary	65.89
AMAZON CAPITAL SERVICES	11/19/2020	450684	Sheila Ross-Austin MS-"You are there...Virtually!" Google 87002823-01 Official Cardboard-2 Pack-Brown	1,125.00

CHECK REGISTER
DATE ENDING 11-30-2020

AMAZON CAPITAL SERVICES	11/19/2020	450684	secretary's desk divider for Galveston ISD CTE office	85.98
AMAZON CAPITAL SERVICES	11/19/2020	450684	SECRETARY'S DESL PROTECTION FOR GALVESTON ISD CTE OFFICE	286.86
AMBUTECH INC	11/19/2020	450685	Ambutech order for Lori Sweatt - Mobility Canes,Grips, Hook on Roller	133.51
AT&T	11/19/2020	450687	11/3/20 - 12/2/20 CENTRAL	85.16
AT&T	11/19/2020	450686	11/3/2020- 12/2/2020 DATE CENTRAL 409-770-0177 055 2	307.47
AT&T	11/19/2020	450688	11/3/2020- 12/2/2020 DATE STADIUM 409-770-9027 676 8	85.16
AT&T SOUTHWEST	11/19/2020	450690	11/5/20 IP FLEXIBLE	1,353.77
AT&T SOUTHWEST	11/19/2020	450689	11/5/20 - 12/4/20 ADI ACCESS CHARGE	985.60
ATHLETIC SUPPLY, INC.	11/19/2020	450691	Athletics-Supplies and Materials/Gear-BHS FB	3,784.70
ATHLETIC SUPPLY, INC.	11/19/2020	450691	Athletics-Supplies and Materials- UNI- BHS FB	22,310.00
AUTO PLUS	11/19/2020	450692	FOR PURCHASE OF PARTS FLEET VEHICLES & BUSES 2020-2021	45.54
AUTO PLUS	11/19/2020	450692	FOR PURCHASE OF PARTS FLEET VEHICLES & BUSES 2020-2021	32.72
AUTO PLUS	11/19/2020	450692	FOR PURCHASE OF PARTS FLEET VEHICLES & BUSES 2020-2021	145.08
AUTO PLUS	11/19/2020	450692	FOR PURCHASE OF PARTS FLEET VEHICLES & BUSES 2020-2021	(120.00)
AUTO PLUS	11/19/2020	450692	FOR PURCHASE OF PARTS FLEET VEHICLES & BUSES 2020-2021	52.80
AUTO PLUS	11/19/2020	450692	FOR PURCHASE OF PARTS FLEET VEHICLES & BUSES 2020-2021	19.66
AUTO PLUS	11/19/2020	450692	FOR PURCHASE OF PARTS FLEET VEHICLES & BUSES 2020-2021	56.63
AUTO PLUS	11/19/2020	450692	FOR PURCHASE OF PARTS FLEET VEHICLES & BUSES 2020-2021	122.52
AUTO PLUS	11/19/2020	450692	FOR PURCHASE OF PARTS FLEET VEHICLES & BUSES 2020-2021	18.58
AUTO PLUS	11/19/2020	450692	FOR PURCHASE OF PARTS FLEET VEHICLES & BUSES 2020-2021	45.54
AUTO PLUS	11/19/2020	450692	FOR PURCHASE OF PARTS FLEET VEHICLES & BUSES 2020-2021	47.76
AUTO PLUS	11/19/2020	450692	FOR PURCHASE OF PARTS FLEET VEHICLES & BUSES 2020-2021	11.73
AUTO PLUS	11/19/2020	450692	FOR PURCHASE OF PARTS FLEET VEHICLES & BUSES 2020-2021	51.54
AUTO PLUS	11/19/2020	450692	FOR PURCHASE OF PARTS FLEET VEHICLES & BUSES 2020-2021	2.72
AUTO PLUS	11/19/2020	450692	FOR PURCHASE OF PARTS FLEET VEHICLES & BUSES 2020-2021	7.32
AUTO PLUS	11/19/2020	450692	FOR PURCHASE OF PARTS FLEET VEHICLES & BUSES 2020-2021	12.07

CHECK REGISTER
DATE ENDING 11-30-2020

AUTO PLUS	11/19/2020	450692	VEHICLES & BUSES 2020-2021 FOR PURCHASE OF PARTS FLEET	12.07
AUTO PLUS	11/19/2020	450692	VEHICLES & BUSES 2020-2021 FOR PURCHASE OF PARTS FLEET	50.48
AUTO PLUS	11/19/2020	450692	VEHICLES & BUSES 2020-2021 FOR PURCHASE OF PARTS FLEET	118.64
AUTO PLUS	11/19/2020	450692	VEHICLES & BUSES 2020-2021 FOR PURCHASE OF PARTS FLEET	191.33
AUTO PLUS	11/19/2020	450692	VEHICLES & BUSES 2020-2021 FOR PURCHASE OF PARTS FLEET	4.76
AUTO PLUS	11/19/2020	450692	VEHICLES & BUSES 2020-2021 FOR PURCHASE OF PARTS FLEET	241.88
AUTO PLUS	11/19/2020	450692	VEHICLES & BUSES 2020-2021 FOR PURCHASE OF PARTS FLEET	86.13
AUTO PLUS	11/19/2020	450692	VEHICLES & BUSES 2020-2021 FOR PURCHASE OF PARTS FLEET	539.12
AUTO PLUS	11/19/2020	450692	VEHICLES & BUSES 2020-2021 FOR PURCHASE OF PARTS FLEET	(118.64)
AUTO PLUS	11/19/2020	450692	VEHICLES & BUSES 2020-2021 FOR PURCHASE OF PARTS FLEET	118.64
AUTO PLUS	11/19/2020	450692	VEHICLES & BUSES 2020-2021 FOR PURCHASE OF PARTS FLEET	1.15
AUTO PLUS	11/19/2020	450692	VEHICLES & BUSES 2020-2021 FOR PURCHASE OF PARTS FLEET	38.85
AUTO PLUS	11/19/2020	450692	VEHICLES & BUSES 2020-2021 FOR PURCHASE OF PARTS FLEET	4.92
AUTO PLUS	11/19/2020	450692	VEHICLES & BUSES 2020-2021 FOR PURCHASE OF PARTS FLEET	2.57
B & H PHOTO VIDEO PRO AUDIO	11/19/2020	450693	ITEMS NEEDED FOR GISD BHS ROBOTICS TO ENHANCE THE LEARNING OBJECTIVES WITHIN THE PROGRAM	307.00
B & H PHOTO VIDEO PRO AUDIO	11/19/2020	450693	GEF AWARD RECIPIENT - MEDIA ARTS VIDEO REMOTE PROJ." EQUIP/MATERIALS	796.98
B & H PHOTO VIDEO PRO AUDIO	11/19/2020	450693	BURNET - INSTRUCTIONAL TECH SUPPLIES	183.95
B & H PHOTO VIDEO PRO AUDIO	11/19/2020	450693	GEF AWARD RECIPIENT - MEDIA ARTS VIDEO REMOTE PROJ." EQUIP/MATERIALS	1,527.14
BINSWANGER GLASS #078	11/19/2020	450694	Open PO needed for the purchase of pre cut glass	311.10
BINSWANGER GLASS #078	11/19/2020	450694	Open PO needed for the purchase of pre cut glass	181.80
BSN SPORTS LLC	11/19/2020	450695	BOYS BASKETBALL ADDITIONAL MASK ORDER	347.75
CAREERSAFE ONLINE	11/19/2020	450696	Careersafe Interviewing Softskills 20-21 for Galveston ISD	499.00

CHECK REGISTER
DATE ENDING 11-30-2020

CAROLINA BIOLOGICAL SUPPLY CO	11/19/2020	450697	Zahrah Ektefaei "Cutting through COVID"SAIL GEF Grants to Teachers QUOTE NUMBER:466398 SQ PSYngScientistAnimalDissectKit (200) Freight and Handling (1) ATTN: ZAHRAH EKTEFAEI SAIL PROGRAM	2,943.00
CAROLINA BIOLOGICAL SUPPLY CO	11/19/2020	450697	Zahrah Ektefaei "Cutting through COVID"SAIL GEF Grants to Teachers QUOTE NUMBER:466398 SQ PSYngScientistAnimalDissectKit (200) Freight and Handling (1) ATTN: ZAHRAH EKTEFAEI SAIL PROGRAM	1,197.00
CDW GOVERNMENT LLC	11/19/2020	450698	Replacement Display for GCC Advisor	208.00
CDW GOVERNMENT LLC	11/19/2020	450698	TECHNOLOGY SUPPLIES-QUOTE#LRCQ761	216.21
CHALLENGE OFFICE PROD INC	11/19/2020	88	Bond 2018 - District Wide White Board and Bulletin Board Project	6,611.25
CHALLENGE OFFICE PROD INC	11/19/2020	1840	CLASSROOM SUPPLIES	55.75
CHALLENGE OFFICE PROD INC	11/19/2020	450699	Office Furniture CHOICE PARTNERS 19/025KD-04	264.99
CHALLENGE OFFICE PROD INC	11/19/2020	450699	COVID SUPPLIES FOR THE OFFICE	94.38
CHALLENGE OFFICE PROD INC	11/19/2020	450699	COVID SUPPLIES FOR THE OFFICE	44.99
CHALLENGE OFFICE PROD INC	11/19/2020	450699	NAME PLATES FOR BUSINESS OFFICE CHOICE PARTNERS AGREEMENT 19/025KD-04	33.60
CHALLENGE OFFICE PROD INC	11/19/2020	450699	OFFICE SUPPLIES FOR BUSINESS OFFICE CHOICE PARTNERS AGREEMENT 19/025KD-04	13.12
CHALLENGE OFFICE PROD INC	11/19/2020	450699	Order for GEF recipient Dr. Jean Langevine. Campus : Burnet Title: Taking Stream Home.	473.45
CHALLENGE OFFICE PROD INC	11/19/2020	450699	SUPPLIES-PAPER	2,007.50
CHALLENGE OFFICE PROD INC	11/19/2020	450699	CLASSROOM SUPPLIES-2ND	120.50
CHALLENGE OFFICE PROD INC	11/19/2020	450699	School Supplies	380.13
CHALLENGE OFFICE PROD INC	11/19/2020	450699	CHALLENGE OFFICE	163.75
CHALLENGE OFFICE PROD INC	11/19/2020	450699	CLASSROOM SUPPLIES	11.48
CHALLENGE OFFICE PROD INC	11/19/2020	450699	Supplies for Central Middle School Art CHOICE PARTNERS 19-025KD-04	232.88
CITY ELECTRIC SUPPLY	11/19/2020	450700	SUPPLIES FOR 2020-2021 OCTOBER 2020- MAY 2021	85.52
CITY ELECTRIC SUPPLY	11/19/2020	450700	SUPPLIES FOR 2020-2021 OCTOBER 2020- MAY 2021	15.72

CHECK REGISTER
DATE ENDING 11-30-2020

CITY ELECTRIC SUPPLY	11/19/2020	450700	SUPPLIES FOR 2020-2021 OCTOBER 2020- MAY 2021	180.48
CITY OF GALVESTON	11/19/2020	450701	9/21/20 - 10/20/20 CENTRAL - SPRINKLER	880.93
CITY OF GALVESTON	11/19/2020	450701	9/21/20 - 10/20/20 SF AUSTIN FIRE LINE	324.56
CITY OF GALVESTON	11/19/2020	450701	9/22/22 - 10/22/20 ROSENBERG	372.48
CITY OF GALVESTON	11/19/2020	450701	9/21/20 - 10/20/20 MECC	439.33
CITY OF GALVESTON	11/19/2020	450701	9/21/20 - 10/20/20 SF AUSTIN	1,917.63
CITY OF GALVESTON	11/19/2020	450701	9/21/20 - 10/20/20 CENTRAL	382.80
CITY OF GALVESTON	11/19/2020	450701	9/21/220 - 10/20/20 CENTRAL - SPRINKLER	49.99
CJ CABLING	11/19/2020	450702	OPEN PO FOR NETWORK	259.75
CJ CABLING	11/19/2020	450702	OPEN PO FOR NETWORK	2,192.00
CLASSIC FORD GALVESTON	11/19/2020	450703	FOR REPAIRS MADE TO FLEET VEHICLES 2020-2021	108.24
COBURN SUPPLY CO	11/19/2020	450704	SUPPLIES FOR 2020-2021 SCHOOL YEAR OCTOBER 2020-MAY 2021	284.78
COBURN SUPPLY CO	11/19/2020	450704	SUPPLIES FOR 2020-2021 SCHOOL YEAR OCTOBER 2020-MAY 2021	272.53
COBURN SUPPLY CO	11/19/2020	450704	SUPPLIES FOR 2020-2021 SCHOOL YEAR OCTOBER 2020-MAY 2021	9.00
COBURN SUPPLY CO	11/19/2020	450704	SUPPLIES FOR 2020-2021 SCHOOL YEAR OCTOBER 2020-MAY 2021	33.30
COBURN SUPPLY CO	11/19/2020	450704	SUPPLIES FOR 2020-2021 SCHOOL YEAR OCTOBER 2020-MAY 2021	11.53
COBURN SUPPLY CO	11/19/2020	450704	SUPPLIES FOR 2020-2021 SCHOOL YEAR OCTOBER 2020-MAY 2021	92.06
COBURN SUPPLY CO	11/19/2020	450704	SUPPLIES FOR 2020-2021 SCHOOL YEAR OCTOBER 2020-MAY 2021	203.50
COBURN SUPPLY CO	11/19/2020	450704	SUPPLIES FOR 2020-2021 SCHOOL YEAR OCTOBER 2020-MAY 2021	15.82
COBURN SUPPLY CO	11/19/2020	450704	SUPPLIES FOR 2020-2021 SCHOOL YEAR OCTOBER 2020-MAY 2021	378.47
COBURN SUPPLY CO	11/19/2020	450704	SUPPLIES FOR 2020-2021 SCHOOL YEAR OCTOBER 2020-MAY 2021	60.14
COBURN SUPPLY CO	11/19/2020	450704	SUPPLIES FOR 2020-2021 SCHOOL YEAR OCTOBER 2020-MAY 2021	486.00
COBURN SUPPLY CO	11/19/2020	450704	SUPPLIES FOR 2020-2021 SCHOOL YEAR OCTOBER 2020-MAY 2021	1,142.27
COBURN SUPPLY CO	11/19/2020	450704	SUPPLIES FOR 2020-2021 SCHOOL YEAR OCTOBER 2020-MAY 2021	59.92
CODECOMBAT INC	11/19/2020	450705	Code Combat usage by SAIL PLTW students assigned to Patrick Burke-Galveston ISD	4,200.00
COMCAST	11/19/2020	450706	Open" P.O. Monthly Contracted Service Comcast for Chief Amador in the Police Department	24.42
CROWN EQUIP.CORP/CROWN LIFTR	11/19/2020	450707	Forklift Maintenance	89.00

CHECK REGISTER
DATE ENDING 11-30-2020

CROWN EQUIP.CORP/CROWN LIFTTR	11/19/2020	450707	Forklift Maintenance	150.00
DECKER, STEPHANI	11/19/2020	450708	OPEN PURCHASE ORDER FOR STEPHANI DECKER FOR FY 2020-21	2,913.75
DELL MARKETING LP	11/19/2020	450709	BURNET - DELL (360) CHROMEBOOKS	19,868.40
DELL MARKETING LP	11/19/2020	450709	CRENSHAW - (24) CHROMEBOOKS FOR STEM LAB	6,984.00
DELL MARKETING LP	11/19/2020	450709	CRENSHAW - (24) CHROMEBOOKS FOR STEM LAB	1,324.56
DPI DIGITAL PRINTING & I NEED A SIG	11/19/2020	450710	FOR PURCHASE OF BUS DECALS/REFLECTIVE 2020-2021	243.00
EXAMITY INC.	11/19/2020	450711	Examity Invoice for students taking TSI remotely-October 2020 Galveston ISD	200.00
EXAMITY INC.	11/19/2020	450711	Galveston ISD Ball HS September Proctoring College Board - Accuplacer for student TSI testing	750.00
GLAZIER FOODS COMPANY	11/19/2020	410	Food Products	76.68
GLAZIER FOODS COMPANY	11/19/2020	410	Food Products	1,551.28
GLAZIER FOODS COMPANY	11/19/2020	410	Food Products	1,283.99
GLAZIER FOODS COMPANY	11/19/2020	410	Food Products	76.68
GLAZIER FOODS COMPANY	11/19/2020	410	Food Products	1,535.99
GLAZIER FOODS COMPANY	11/19/2020	410	Food Products	118.63
GLAZIER FOODS COMPANY	11/19/2020	410	Food Products	2,867.41
GLAZIER FOODS COMPANY	11/19/2020	410	Food Products	160.58
GLAZIER FOODS COMPANY	11/19/2020	410	Food Products	2,550.30
GLAZIER FOODS COMPANY	11/19/2020	410	Food Products	118.63
GLAZIER FOODS COMPANY	11/19/2020	410	Food Products	2,937.67
GLAZIER FOODS COMPANY	11/19/2020	410	Food Products	118.63
GLAZIER FOODS COMPANY	11/19/2020	410	Food Products	(22.18)
GLAZIER FOODS COMPANY	11/19/2020	410	Food Products	118.63
GLAZIER FOODS COMPANY	11/19/2020	410	Food Products	3,141.69
GLAZIER FOODS COMPANY	11/19/2020	410	Food Products	3,557.99
GLAZIER FOODS COMPANY	11/19/2020	410	Food Products	118.63
GLAZIER FOODS COMPANY	11/19/2020	410	Food Products	1,260.93
GLAZIER FOODS COMPANY	11/19/2020	410	Food Products	1,177.09
GLAZIER FOODS COMPANY	11/19/2020	410	Food Products	3,069.80
GLAZIER FOODS COMPANY	11/19/2020	410	Food Products	76.68
GLAZIER FOODS COMPANY	11/19/2020	410	Food Products	6,121.80
GLAZIER FOODS COMPANY	11/19/2020	410	Food Products	76.68
GLAZIER FOODS COMPANY	11/19/2020	410	Food Products	195.31
GLAZIER FOODS COMPANY	11/19/2020	410	Food Products	118.63
HARDIES	11/19/2020	411	Produce Products	201.35
HARDIES	11/19/2020	411	Produce Products	293.70
HARDIES	11/19/2020	411	Produce Products	135.95
HARDIES	11/19/2020	411	Produce Products	1,268.10
HARDIES	11/19/2020	411	Produce Products	156.45
HARDIES	11/19/2020	411	Produce Products	361.55

CHECK REGISTER
DATE ENDING 11-30-2020

HARDIES	11/19/2020	411	Produce Products	136.85
HARDIES	11/19/2020	411	Produce Products	502.95
HARDIES	11/19/2020	411	Produce Products	1,769.95
HARDIES	11/19/2020	411	Produce Products	(12.25)
HARDIES	11/19/2020	411	Produce Products	474.92
HARDIES	11/19/2020	411	Produce Products	292.25
HARDIES	11/19/2020	411	Produce Products	81.31
HARDIES	11/19/2020	411	Produce Products	488.00
HARDIES	11/19/2020	411	Produce Products	102.46
HEINEMANN	11/19/2020	450712	LLI K-12 training for Hawsey Nov 9-12	635.00
HICKS CO, W U-HAUL	11/19/2020	450713	VEHICLES REGISTRATION INSPECTION 2020-2021	40.00
HICKS CO, W U-HAUL	11/19/2020	450713	VEHICLES REGISTRATION INSPECTION 2020-2021	25.50
HICKS CO, W U-HAUL	11/19/2020	450713	VEHICLES REGISTRATION INSPECTION 2020-2021	40.00
HICKS CO, W U-HAUL	11/19/2020	450713	VEHICLES REGISTRATION INSPECTION 2020-2021	40.00
HICKS CO, W U-HAUL	11/19/2020	450713	VEHICLES REGISTRATION INSPECTION 2020-2021	40.00
HICKS CO, W U-HAUL	11/19/2020	450713	VEHICLES REGISTRATION INSPECTION 2020-2021	40.00
HICKS CO, W U-HAUL	11/19/2020	450713	VEHICLES REGISTRATION INSPECTION 2020-2021	40.00
HICKS CO, W U-HAUL	11/19/2020	450713	VEHICLES REGISTRATION INSPECTION 2020-2021	40.00
HICKS CO, W U-HAUL	11/19/2020	450713	VEHICLES REGISTRATION INSPECTION 2020-2021	40.00
HICKS CO, W U-HAUL	11/19/2020	450713	VEHICLES REGISTRATION INSPECTION 2020-2021	40.00
HOME DEPOT	11/19/2020	450714	SUPPLIES FOR THE 2020-2021 SCHOOL YEAR-OCTOBER 2020-MAY 2021	621.71
HOME DEPOT	11/19/2020	450714	SUPPLIES FOR THE 2020-2021 SCHOOL YEAR-OCTOBER 2020-MAY 2021	59.63
HOME DEPOT	11/19/2020	450714	SUPPLIES FOR THE 2020-2021 SCHOOL YEAR-OCTOBER 2020-MAY 2021	(2.46)
HOME DEPOT	11/19/2020	450714	SUPPLIES FOR THE 2020-2021 SCHOOL YEAR-OCTOBER 2020-MAY 2021	32.28
HOME DEPOT	11/19/2020	450714	SUPPLIES FOR THE 2020-2021 SCHOOL YEAR-OCTOBER 2020-MAY 2021	21.60
HOME DEPOT	11/19/2020	450714	***OPEN PURCHASE ORDER*** SUPPLIES FOR RR MUSEUM WALK THROUGH STORYBOOK EVENT- FUNDS REQUEST APPROVED PURCHASE REQUEST APPROVED	442.26
HOME DEPOT	11/19/2020	450714	Open PO for Galveston Ball HS	59.88

CHECK REGISTER
DATE ENDING 11-30-2020

			trades, robotics , Fab-Lab and engineering classrooms; to support materials, supplies, and project based learning materials	
HOPKINS, DEBBIE	11/19/2020	450715	EMPLOYEE REIMBURSEMENT	84.97
HOUGHTON MIFFLIN HARCOURT PUB	11/19/2020	450716	ADDITIONAL MATH RESOURCE CONSUMABLES- SPANISH GO MATH / SCIENCE FUSION BUYBOARD AGREEMENT 573-18 INSTRUCTIONAL MATERIALS, CLASSROOM TEACHING SUPPLIES, & EQUIPMENT	117.00
IDENTIFIX INC	11/19/2020	450717	Annual Identifix Educational Direct Hit subscription renewal for Autoshop classroom	1,068.00
INTEX FLOORING LLC	11/19/2020	450718	Ball - replace carpet with LVT in 1092 Suite rooms	10,295.14
KLEEN JANITORIAL SUPPLY CO	11/19/2020	450719	custodial supplies-OCTOBER 2020-MAY 2021	121.50
KLEEN JANITORIAL SUPPLY CO	11/19/2020	412	Misc. Supplies	88.90
KLEEN JANITORIAL SUPPLY CO	11/19/2020	412	Misc. Supplies	22.42
KLEEN JANITORIAL SUPPLY CO	11/19/2020	412	Misc. Supplies	70.90
KROGER-SOUTHWEST	11/19/2020	1841	Student Water for COVID precautions	11.96
KROGER-SOUTHWEST	11/19/2020	1841	****OPEN PURCHASE ORDER**** Refreshments for Galveston BHS Robotics Competition	120.92
KROGER-SOUTHWEST	11/19/2020	1841	****OPEN PURCHASE ORDER**** Refreshments for Galveston BHS Robotics Competition	(120.92)
KROGER-SOUTHWEST	11/19/2020	1841	****OPEN PURCHASE ORDER**** Refreshments for Galveston BHS Robotics Competition	113.90
KROGER-SOUTHWEST	11/19/2020	450720	MIS. OPERATING EXPENSES	27.98
KROGER-SOUTHWEST	11/19/2020	450720	Open Kroger PO/ Registrar's & Attendance Clerks appreciation snacks/ Lea Walker	16.99
KURZ & CO.	11/19/2020	413	Bread Products	108.91
KURZ & CO.	11/19/2020	413	Bread Products	280.75
KURZ & CO.	11/19/2020	413	Bread Products	51.66
KURZ & CO.	11/19/2020	413	Bread Products	138.55
KURZ & CO.	11/19/2020	413	Bread Products	51.66
LAKESHORE LEARNING MATERIALS	11/19/2020	450721	CAMPUS SUPPLIES	40.83
LIBERTY SOURCE LP	11/19/2020	450722	PRE-K SOFTWARE (TANGO)	2,612.50
LITTLE RED BOX, LLC	11/19/2020	450723	****OPEN PURCHASE ORDER**** GROCERIES FOR MONTHLY VIRTUAL COOKING CLASSES NOV	1,784.49

CHECK REGISTER
DATE ENDING 11-30-2020

MATERA PAPER COMPANY	11/19/2020	450724	2020-MARCH 2021 50 FAMILIES PER CLASS- FUNDS REQUEST SUPPLIES NEEDED FOR VARIOUS SCHOOLS FOR THE 2020-2021 for Month of OCTOBER 2020-MAY	68.73
MATERA PAPER COMPANY	11/19/2020	450724	SUPPLIES NEEDED FOR VARIOUS SCHOOLS FOR THE 2020-2021 for Month of OCTOBER 2020-MAY	6.10
MATERA PAPER COMPANY	11/19/2020	450724	SUPPLIES NEEDED FOR VARIOUS SCHOOLS FOR THE 2020-2021 for Month of OCTOBER 2020-MAY	63.60
MATERA PAPER COMPANY	11/19/2020	450724	SUPPLIES NEEDED FOR VARIOUS SCHOOLS FOR THE 2020-2021 for Month of OCTOBER 2020-MAY	42.40
MATERA PAPER COMPANY	11/19/2020	450724	SUPPLIES NEEDED FOR VARIOUS SCHOOLS FOR THE 2020-2021 for Month of OCTOBER 2020-MAY	1.83
MATERA PAPER COMPANY	11/19/2020	450724	SUPPLIES NEEDED FOR VARIOUS SCHOOLS FOR THE 2020-2021 for Month of OCTOBER 2020-MAY	63.60
MATERA PAPER COMPANY	11/19/2020	450724	SUPPLIES NEEDED FOR VARIOUS SCHOOLS FOR THE 2020-2021 for Month of OCTOBER 2020-MAY	662.05
MATERA PAPER COMPANY	11/19/2020	450724	SUPPLIES NEEDED FOR VARIOUS SCHOOLS FOR THE 2020-2021 for Month of OCTOBER 2020-MAY	1,348.05
MATERA PAPER COMPANY	11/19/2020	450724	SUPPLIES NEEDED FOR VARIOUS SCHOOLS FOR THE 2020-2021 for Month of OCTOBER 2020-MAY	1.78
MATERA PAPER COMPANY	11/19/2020	450724	SUPPLIES NEEDED FOR VARIOUS SCHOOLS FOR THE 2020-2021 for Month of OCTOBER 2020-MAY	2.44
MATERA PAPER COMPANY	11/19/2020	450724	SUPPLIES NEEDED FOR VARIOUS SCHOOLS FOR THE 2020-2021 for Month of OCTOBER 2020-MAY	31.38
MATERA PAPER COMPANY	11/19/2020	450724	SUPPLIES NEEDED FOR VARIOUS SCHOOLS FOR THE 2020-2021 for Month of OCTOBER 2020-MAY	42.40

CHECK REGISTER
DATE ENDING 11-30-2020

MATERA PAPER COMPANY	11/19/2020	450724	SUPPLIES NEEDED FOR VARIOUS SCHOOLS FOR THE 2020-2021 for Month of OCTOBER 2020-MAY 2021	42.40
MOODY EARLY CHILDHOOD CENTER	11/19/2020	450725	MECC PAYMENTS FOR BASIC FUNDING ALLOTMENT-FLOW THRU	17,951.25
MOODY GARDEN CONVENTION CENT	11/19/2020	450726	VENUE CONTRACT-BHS GRADUATION FY 20-21	4,000.00
MOTOROLA SOLUTIONS	11/19/2020	450727	Repair & MTN Equipment for Police Department Radio Equipment HGAC CO-OP AGREEMENT RA05-18	384.90
MUSIC & ARTS CENTER	11/19/2020	450728	repairs for Ball High Band	380.00
MUSIC & ARTS CENTER	11/19/2020	450728	repair of saxophones for ball high band	115.00
NASCO	11/19/2020	450729	Supplies & Materials	166.08
NETRIX LLC	11/19/2020	450730	MICROSOFT INTUNE CLOUD-BASED	7,125.00
O'REILLY AUTO PARTS	11/19/2020	450731	Galveston Ball HS open PO to O' Reilly's for Ball HS automotive program	34.50
O'REILLY AUTO PARTS	11/19/2020	450731	Galveston Ball HS open PO to O' Reilly's for Ball HS automotive program	93.11
O'REILLY AUTO PARTS	11/19/2020	450731	Galveston Ball HS open PO to O' Reilly's for Ball HS automotive program	20.68
O'REILLY AUTO PARTS	11/19/2020	450731	Galveston Ball HS open PO to O' Reilly's for Ball HS automotive program	4.10
OTC BRANDS INC	11/19/2020	450732	BURNET - K-4 SUPPLIES FOR UNITS	32.00
OTC BRANDS INC	11/19/2020	450732	BURNET - K-4 SUPPLIES FOR UNITS	928.00
OTC BRANDS INC	11/19/2020	450732	CAMPUS SUPPLIES	65.87
OTC BRANDS INC	11/19/2020	450732	CAMPUS SUPPLIES	56.47
PARKER, BETH	11/19/2020	1842	REIMBURSEMENT	80.00
PERDUE, BRANDON, FIELDER,	11/19/2020	450733	PROPERTY VALUE AUDIT	23,079.53
PETROLEUM TRADERS CORPORATION	11/19/2020	450734	DEISEL & DASOLINE FOR ALL FLEET VEHICLES & BUSES 2020-2021	8,228.65
PITSCO EDUCATION	11/19/2020	450735	Order for GEF recipient Dr. Jean Langevine. Campus: Burnet Title: Taking Stream Home.	166.93
POSITIVE PROMOTIONS, INC.	11/19/2020	1843	BUTTONS & BUMPER STICKER	1,184.00
QUALITY HARDWOOD FLOORS, INC	11/19/2020	450736	Ball - Lower Gym Floor Repair by exterior door east side	2,100.00
REALLY GOOD STUFF LLC	11/19/2020	450737	SEL KITS FOR PARKER AND CRENSHAW	182.78
REALLY GOOD STUFF LLC	11/19/2020	450737	CLASSROOM SUPPLIES-2ND	54.74

CHECK REGISTER
DATE ENDING 11-30-2020

REGION 4 ESC BUSINESS OFFICE	11/19/2020	450738	REGISTRATIONS FOR REGION 4 -FEDERAL PROG. TRAININGS--JEFF PAYSEE & SYLVIA ANDREWS	70.00
REGION 4 ESC BUSINESS OFFICE	11/19/2020	450738	REGION 4-SESSION 1566169/MATH THAT STICKS (VIRTUAL) 11/07/2020-LISA BRUNDRETT	70.00
REGION 4 ESC BUSINESS OFFICE	11/19/2020	450738	Region 4 Open PO- SPED Training	100.00
REGION 4 ESC BUSINESS OFFICE	11/19/2020	450738	Region 4 Open PO- SPED Training	150.00
REGION 4 ESC BUSINESS OFFICE	11/19/2020	450738	Region 4 Open PO- SPED Training	200.00
REGION XI EDUCATION SERVICE CENT	11/19/2020	450739	DISCOVERY EDUCATION STREAMING BASE SUBSCRIPTION 2020-2021	8,843.94
REPUBLIC PARTS CO	11/19/2020	450740	SUPPLIES FOR 2020-2021 SCHOOL YEAR-OCTOBER 2020-MAY 2021	100.20
REPUBLIC PARTS CO	11/19/2020	450740	SUPPLIES FOR 2020-2021 SCHOOL YEAR-OCTOBER 2020-MAY 2021	66.42
REPUBLIC PARTS CO	11/19/2020	450740	FOR THE PIURCHASE OF PARTS FOR BUSES & FLEET VEHICLES 2020-2021	238.60
REPUBLIC PARTS CO	11/19/2020	450740	FOR THE PIURCHASE OF PARTS FOR BUSES & FLEET VEHICLES 2020-2021	21.99
REPUBLIC PARTS CO	11/19/2020	450740	FOR THE PIURCHASE OF PARTS FOR BUSES & FLEET VEHICLES 2020-2021	67.41
REPUBLIC PARTS CO	11/19/2020	450740	FOR THE PIURCHASE OF PARTS FOR BUSES & FLEET VEHICLES 2020-2021	32.43
RIVERSIDE INSIGHTS	11/19/2020	450741	IOWA & Logramos for 20-21 Online & Onsite	13,700.25
SCHOOL NURSE SUPPLY, INC	11/19/2020	450742	SUPPLIES-NURSE	477.51
SCHOOL NURSE SUPPLY, INC	11/19/2020	450742	School Nurse Supply, Inc. - qUOTE#0815323 - \$401.03	401.03
SCHOOL OUTFITTERS	11/19/2020	450743	GEF Grant - Michelle Lujan, "Innovation for the 21st Century," Oppe Elementary	1,399.98
SCHOOL SPECIALTY	11/19/2020	450744	BURNET - OUT DOOR DISPLAY FOR FAMILY OUTREACH AND COMMUNICATION	839.48
SCHOOL TECHNOLOGY ASSOCIATES	11/19/2020	450745	TIME CLOCK WALL MOUNT	196.34
SHERWIN-WILLIAMS CO, THE	11/19/2020	450746	SUPPLIES FOR SCHOOL YEAR OCTOBER 2020-MAY 2021 Per Region 5 ESC Coop exp	250.73
SPARKLETTS	11/19/2020	1844	drinking water for the Facilities Dept	51.72
TABE	11/19/2020	450747	REGISTRATION - TABE ONLINE	250.00

4/30/2022

CHECK REGISTER
DATE ENDING 11-30-2020

			CONFERENCE / SATURDAY - OCT. 10TH	
TASC DISTRICT VII	11/19/2020	450748	TASC/TASSP LEADERSHIP CURRICULUM FOR STUDENTS	250.00
TERMINIX PROCESING CENTER	11/19/2020	450749	Stadium - Hornet treatment	1,500.00
TEXAS GAS SERVICE	11/19/2020	450750	10/5/20 - 11/3/20 OPPE	93.33
TEXAS GAS SERVICE	11/19/2020	450750	10/2/20 - 11/02/20 AIM (ALAMO)	137.67
TEXAS GAS SERVICE	11/19/2020	450750	10/2/20 - 11/2/20 PARKER	156.17
TEXAS GAS SERVICE	11/19/2020	450750	10/5/20 - 11/3/20 TRANSPORTATION	64.12
TEXAS GAS SERVICE	11/19/2020	450750	METER READING 10/02/20-11/02/20	62.62
TEXAS GAS SERVICE	11/19/2020	450750	10/02/20-11/02/20 BURNET	132.72
TEXAS GAS SERVICE	11/19/2020	450750	10/5/20 - 11/3/20 COLLEGIATE (WEIS)	81.75
TEXAS GAS SERVICE	11/19/2020	450750	10/2/20 - 11/2/20 ADMIN BLDG	58.15
TEXAS GAS SERVICE	11/19/2020	450750	10/2/20 - 11/2/20 BALL HIGH	632.45
THOMAS BUS GULF COAST GP INC	11/19/2020	450751	FOR PURCHASE OF PARTS/LUBE & OIL 2020-2021	132.07
THOMAS BUS GULF COAST GP INC	11/19/2020	450751	FOR PURCHASE OF PARTS/LUBE & OIL 2020-2021	23.20
TMEA REGION 17	11/19/2020	450752	All Region (Band) Austin Middle School	24.00
TOPGEAR	11/19/2020	450753	FACILITIES UNIFORMS	124.95
TOPGEAR	11/19/2020	450753	FACILITIES UNIFORMS	219.87
TREASURE ISLAND TROPHIES	11/19/2020	450754	Needed Room Plaques for Ball High	250.00
UNITED PARCEL SERVICE	11/19/2020	450755	SCHEDULED PICK-UP	13.52
UTMB AT GALVESTON	11/19/2020	450756	UTMB REHAB SERVICES	8,250.00
WELLS FARGO FINANCIAL SERVICES, I	11/19/2020	450757	OPEN PURCHASE ORDER FOR LEASE AGREEMENT 2020-21	10,552.42
WEST ISLE URGENT CARE	11/19/2020	450758	Drug Testing - Workmans Comp 2020-21 School Year	35.00
WINFIELD	11/19/2020	450759	Needed Tastar Insecticide	414.56
WINFIELD	11/19/2020	450759	Needed Rye Grass Seed for Courville, Weis, Tor & the Softball Fields. BUYBOARD AGREEMENT 611-20	4,199.20
WINFIELD	11/19/2020	450759	Needed Rye Grass Seed for Courville, Weis, Tor & the Softball Fields. BUYBOARD AGREEMENT 611-20	(4,199.20)
WOOD ALTERNATOR AND STARTER S	11/19/2020	450760	****OPEN PURCHASE ORDER**** PURCHASE OF ALTERNATORS FOR BUSES 2020-21	350.25
WOODWIND & BRASSWIND	11/19/2020	1845	WOODWIND BRASSWIND - #CO10272020034W	498.75
BAY AREA REAL PROPERTY APPRAISE	11/20/2020	450762	REAL PROPERTY APPRAISAL- BOLIVAR PENINSULA	1,800.00

CHECK REGISTER
DATE ENDING 11-30-2020

DESKINS, MELISSA	11/20/2020	202100023	Contracted Services	280.00
MICHELETTI, JENNY	11/20/2020	202100024	Contracted Services	1,328.00
TOTAL				1,907,740.19

Action Sheet

MEETING DATE:

December 16, 2020

AGENDA ITEM:

Consider approval of the minutes from the Regular School Board Meeting on November 18, 2020

RECOMMENDATION:

I move that the Board of Trustees approve the minutes from the Regular School Board Meeting on November 18, 2020.

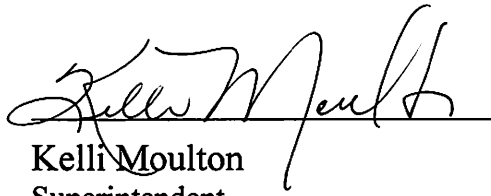

Kelli Moulton
Superintendent

Minutes of Regular Meeting

The Board of Trustees Galveston Independent School District

A Regular Meeting with members of the Galveston ISD Board of Trustees was held November 18, 2020, beginning at 6:30 PM in the Lovenberg Administration Building, 3904 Avenue T, Galveston, TX 77550.

Notice was given pursuant to Texas Government Code Section 551.127 as modified by the Texas Attorney General, that due to the state of emergency declared by Governor Abbott on behalf of the State of Texas, and President Trump on behalf of the United States of America regarding the spread of coronavirus/COVID-19 (hereafter "COVID-19"), one or more members of the Galveston ISD Board of Trustees may attend this meeting via videoconference in order to properly mitigate the spread of COVID-19, pursuant to State and local emergency/disaster declarations. Notice is given that Galveston ISD intended to conduct this meeting via videoconference. As required by the temporary suspension, Galveston ISD:

- Provided online written notice containing a free-of-charge website link, as well as an electronic copy of any agenda packet, before conducting this meeting via videoconference; specifically, the public may have used the following free-of-charge website link: <https://www.gisd.org/site/Default.aspx?PageID=5397>; or a live broadcast on Channel 17.
- Provided the public with access and a means to participate in the meeting, at 3904 Ave T Galveston, TX 77550; or by telephone at 409-766-5139; and
- Provided the public with access to a recording of the meeting.

The subjects discussed or considered or upon which any formal action may be taken are as listed below. The subjects to be discussed do not have to be taken in the order shown on this meeting notice.

Board members in attendance: Wagner, O'Neal, Jobe, Brown, Masel, Smecca, and Lakin
Administration in attendance: Kelli Moulton, Connie Morgenroth, Annette Scott, Billy Rudolph, Audrey Torres, April Pinkham, Walter Fortune, Paul Byers, and Dyann Polzin.

Audio visual recording of this meeting can be found online at:
<https://gisd.viebit.com/index.php?folder=ALL>

- 1) Call to order Open Session in the Board Room of the Lovenberg Administration Building, 3904 Avenue T, Galveston, Texas. --6:30pm
- 2) Pledge of Allegiance to the United States flag and the Texas flag.
Moved from Regular Agenda 9A - Swearing in of Trustees Masel and Smecca --6:32pm
- 3) Citizen's Request to Address the Board on Agenda and Non-Agenda Items. Please complete sign-up sheets available in the lobby prior to the start of the meeting. --6:34pm
Michelle Pedallino spoke on behalf of the SAIL program.
Elizabeth Beeton spoke against Austin closing.

Ken Jencks spoke against Austin closing.
Don Davison spoke against Austin closing.
Manuel Alvarado spoke against Austin closing.
Alma Jiminez spoke against Austin closing.
Sandra Tetley spoke against closing Austin.
Laura Beebe spoke against closing Austin.
Xochiti Gaskin spoke in favor of Middle school realignment.
Barbie Cahill spoke in favor of Middle school realignment.
Premal Patel spoke in favor of Middle school realignment.
Erin Barnhart spoke in favor of Middle school realignment.
Lauren Scott spoke in favor of Middle school realignment.
Georgia Scott spoke in favor of Middle school realignment.
Meg Fagg spoke in favor of Middle school realignment.
Thomas Overhose spoke against closing Austin.
Robert Davis spoke against closing Austin.
Paul Morgan spoke in favor of inclusion.
Janet Hoffman spoke about Ball's hybrid program not being enough for their kids to learn.
Norm Hoffman spoke about Ball's hybrid program not being enough for their kids to learn.
Leslie Clift - Does not want her children going to three middle schools. She wants the matrix removed and a lottery enacted.
Keath Jacoby - Spoke in favor of Middle school realignment.
Micah Simmons - Spoke against closing Austin.
Sara Roberts - Spoke against closing Austin.
Christie Gonzales - Spoke against closing Austin.
Zarah Ecktefaei - Spoke in favor of Middle school realignment.

4) Superintendent's Report --7:44 pm

A) Update on Returning to Learning 2020-2021

Spoke about Enrollment, Technology, COVID-19, and tips for Thanksgiving and the holidays.
--8:02 pm - Board comments - Masel - Asked that info about COVID-19 testing be more advertised. Wagner - Question about equity audit. Jobe - Will it affect teacher instruction time? Smecca - Questioned when hybrid would end at Ball high. Brown - Question about COVID-19 testing.

B) Request for Agenda items Update --8:07 pm

Wagner - Would like a presentation about how the district is working to help failing students.
Masel - Would like a presentation on block scheduling at Ball HS.

C) Board Committee Reports --8:07 pm Deferred.

- 1) Policy Committee Chair- Mr. David O'Neal
- 2) Curriculum Committee Chair- Ms. Monica Wagner
- 3) Facilities/Finance Committee Chair- Mr. Johnny Smecca

5) Financial Reports --8:09 pm

Presented by Connie Morgenroth

Board questions from Smecca and Masel. Report continued by Morgenroth.

--8:20 pm Board comments about IVP. --8:40 Report continued by Morgenroth. --8:43

Deferred maintenance report by Paul Byers. --8:51 Board comments.

6) The Board may recess into Closed Executive Session in the Library as permitted by the Texas Open Meeting Act Government Code Sections 551.071- 551.090 Subchapter D and

E. --8:57 pm -

Should any final action, final decision, or final vote be required in the opinion of the School Board with regard to any matter considered in such closed meeting then the final action, final decision, or final vote shall be either:

A) in the open meeting covered by the Notice upon the reconvening of the public meeting;
or

B) at a subsequent public meeting of the School Board upon notice thereof; as the School Board shall determine.

- A) Personnel
- B) Consultation with Attorney
- C) Real Property

7) Reestablish the open meeting of the Galveston ISD Board of Trustees. --9:27 pm

8) CONSENT AGENDA - Action Items

Motion to approve the consent agenda (Item G withheld) by Ann Masel, Second by Monica Wagner. No discussion. Unanimous in favor.

- A) Consider approval of the minutes from the October 21, 2020 Regular Meeting.
- B) Consider approval of the Board's Time Use Tracker - October 21, 2020
- C) Discuss and consider approval of the Board's Quarterly Progress Tracker.
- D) Consider approval of personnel resignations and recommendations with contracts.
- E) Consider approval of November Budget Amendments
- F) Consider approval of Gifts and Donations.
- G) Consider approval of Purchases >\$50,000 *Deferred*
- H) Discuss and consider approval of payment of Attorney fees.
- I) Discuss and consider the approval for the Causeway Galveston program to apply for a grant from the MHA Center for School Behavioral Health. The amount of the award is \$100,000.
- J) Discuss and Consider for the 2020 2021 school year, delegating contractual authority to obligate the school district under Texas Education Code (TEC) 11.1511 to the superintendent, solely for the purpose of obligating the district under TEC, 48.257 and TEC, Chapter 49, Subchapters A and D, and the rules adopted by the commissioner of education as authorized under TEC, 49.006. This includes approval of the Agreement for the Purchase of Attendance Credit or the Agreement for the Purchase of Attendance Credit (Netting Chapter 48 Funding).
- K) Discuss and consider RFCSP Contract for HVAC Supplies and Services.
- L) Discuss and consider RFCSP Contract for Maintenance and Operating Supplies
- M) Discuss and consider approval of the contract with Adaptive Behavior School East (Harris County Department of Education) for a student in GISD.
- N) Discuss and Consider approval of deferred maintenance projects, not to exceed \$460,000 utilizing fund balance, as presented.
- O) Discuss and consider the approval for the Human Capital Management Department program to apply for the Texas Education Agency Mentor Program Allotment. The estimated amount of the award is \$108,000.
- P) Consider Secondary TEAL (Texas Education Agency Login) approver status for Lea Walker.

9) REGULAR AGENDA- Action Items --9:28 pm -

- A) Administer Oath of Office to Single-Member Districts 5-E and 6-F. --6:32 pm

B) Discuss and consider reorganization of Officers of the GISD Board of Trustees.--
9:28 pm

Ann Masel moved to keep the current officers. Second by David O'Neal. Board President, Tony Brown, Vice-President Johnny Smecca and Secretary Monica Wagner. Unanimous in favor.

C) Discuss and consider Purchase of Real Property --9:30 pm

Motion by Masel, 2nd Lakin to give Dr. Moulton authorization to negotiate on the district's behalf for the purchase of real property. Unanimous in favor.

D) Discuss and consider approval of a Resolution to authorize compensation of employees for the days when the District is closed due to Coronavirus 19. --9:32 pm

Motion by Wagner, Second by Lakin --Unanimous in favor.

E) Discuss and consider approval of resolution adopting a temporary ad valorem tax exemption pursuant to Governor Greg Abbott's disaster declaration and Texas Tax Code §11.35. --9:33 pm

Motion by Smecca, Second by Masel --Unanimous in favor.

F) Discuss and consider approval of resolution to commit fund balance. --9:35pm

Explanation by Connie Morgenroth

Motion by Masel to commit 11 million of the balance for disaster recovery, Second by Smecca -- Unanimous in favor.

10) Suggested Future Agenda Items

11) Board Comments --9:44 pm

David O'Neal

--9:50 Shae Jobe

--9:51 Ann Masel

--9:51 Monica Wagner

--9:54 Mindy Lakin

--9:55 Johnny Smecca

--10:01 Tony Brown

12) Adjournment --10:05

Minutes taken by: Amedia Bly

Approved on: _____

Mr. Tony Brown, President

Mrs. Monica Wagner, Secretary

For the Board of Trustees

Action Sheet

MEETING DATE:

December 16, 2020

AGENDA ITEM:

Consider approval of the Board's Time Use Tracker – November 18, 2020.

A function of the governance structure for Galveston ISD Board of Trustees is to regularly measure the amount of time the board focuses on Framework Activities (Vision, Accountability, Structure, Advocacy, and Other).

The data generated from the tracker will inform the Board of the effective and efficient use of time relative to the District's Vision, Mission and Student Outcome Goals.

RECOMMENDATION:

I move the GISD Board approve the Board's Time Use Tracker for November 18, 2020.

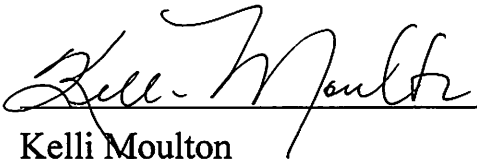

Kelli Moulton
Superintendent

Board's Time Use Tracker November 18, 2020

Framework	Activity	Minutes Used	% of Total Minutes Used	Notes
Vision	Student Outcome Goal Setting		0%	
Vision	Student Outcome Goal Monitoring		0%	
Vision	Constraints Setting		0%	
Vision	Constraints Monitoring		0%	
Accountability	Superintendent Evaluation		0%	
Accountability	Board Self- Evaluation		0%	
Structure	Voting	17	21%	1 - consent, 16 - regular
Advocacy	Community Engagement	55	69%	70 - public comment, 18 - Supt Report
Advocacy	Student/Family Engagement		0%	
Advocacy	Community Training		0%	
Other	Other	8	10%	8 - Board Comments
Total Student Outcome Goal-focused Minutes		72	90%	
Total Minutes		80	100%	

Minutes of Regular Meeting

The Board of Trustees Galveston Independent School District

A Regular Meeting with members of the Galveston ISD Board of Trustees was held November 18, 2020, beginning at 6:30 PM in the Lovenberg Administration Building, 3904 Avenue T, Galveston, TX 77550.

Notice was given pursuant to Texas Government Code Section 551.127 as modified by the Texas Attorney General, that due to the state of emergency declared by Governor Abbott on behalf of the State of Texas, and President Trump on behalf of the United States of America regarding the spread of coronavirus/COVID-19 (hereafter "COVID-19"), one or more members of the Galveston ISD Board of Trustees may attend this meeting via videoconference in order to properly mitigate the spread of COVID-19, pursuant to State and local emergency/disaster declarations. Notice is given that Galveston ISD intended to conduct this meeting via videoconference. As required by the temporary suspension, Galveston ISD:

- Provided online written notice containing a free-of-charge website link, as well as an electronic copy of any agenda packet, before conducting this meeting via videoconference; specifically, the public may have used the following free-of-charge website link: <https://www.gisd.org/site/Default.aspx?PageID=5397>; or a live broadcast on Channel 17.
- Provided the public with access and a means to participate in the meeting, at 3904 Ave T Galveston, TX 77550; or by telephone at 409-766-5139; and
- Provided the public with access to a recording of the meeting.

The subjects discussed or considered or upon which any formal action may be taken are as listed below. The subjects to be discussed do not have to be taken in the order shown on this meeting notice.

Board members in attendance: Wagner, O'Neal, Jobe, Brown, Masel, Smecca, and Lakin
Administration in attendance: Kelli Moulton, Connie Morgenroth, Annette Scott, Billy Rudolph, Audrey Torres, April Pinkham, Walter Fortune, Paul Byers, and Dyann Polzin.

Audio visual recording of this meeting can be found online at:
<https://gisd.viebit.com/index.php?folder=ALL>

- 1) Call to order Open Session in the Board Room of the Lovenberg Administration Building, 3904 Avenue T, Galveston, Texas. --6:30pm
- 2) Pledge of Allegiance to the United States flag and the Texas flag.
Moved from Regular Agenda 9A - Swearing in of Trustees Masel and Smecca --6:32pm
- 3) Citizen's Request to Address the Board on Agenda and Non-Agenda Items. Please complete sign-up sheets available in the lobby prior to the start of the meeting. --6:34pm **70**
Michelle Pedallino spoke on behalf of the SAIL program.
Elizabeth Beeton spoke against Austin closing.

Ken Jencks spoke against Austin closing.
 Don Davison spoke against Austin closing.
 Manuel Alvarado spoke against Austin closing.
 Alma Jiminez spoke against Austin closing.
 Sandra Tetley spoke against closing Austin.
 Laura Beebe spoke against closing Austin.
 Xochiti Gaskin spoke in favor of Middle school realignment.
 Barbie Cahill spoke in favor of Middle school realignment.
 Premal Patel spoke in favor of Middle school realignment.
 Erin Barnhart spoke in favor of Middle school realignment.
 Lauren Scott spoke in favor of Middle school realignment.
 Georgia Scott spoke in favor of Middle school realignment.
 Meg Fagg spoke in favor of Middle school realignment.
 Thomas Overhose spoke against closing Austin.
 Robert Davis spoke against closing Austin.
 Paul Morgan spoke in favor of inclusion.
 Janet Hoffman spoke about Ball's hybrid program not being enough for their kids to learn.
 Norm Hoffman spoke about Ball's hybrid program not being enough for their kids to learn.
 Leslie Clift - Does not want her children going to three middle schools. She wants the matrix removed and a lottery enacted.
 Keath Jacoby - Spoke in favor of Middle school realignment.
 Micah Simmons - Spoke against closing Austin.
 Sara Roberts - Spoke against closing Austin.
 Christie Gonzales - Spoke against closing Austin.
 Zarah Ecktefaei - Spoke in favor of Middle school realignment.

4) Superintendent's Report --7:44 pm **18**

A) Update on Returning to Learning 2020-2021

Spoke about Enrollment, Technology, COVID-19, and tips for Thanksgiving and the holidays.
 --8:02 pm – **5** Board comments - Masel - Asked that info about COVID-19 testing be more advertised. Wagner - Question about equity audit. Jobe - Will it affect teacher instruction time?
 Smecca - Questioned when hybrid would end at Ball high. Brown - Question about COVID-19 testing.

B) Request for Agenda items Update --8:07 pm

Wagner - Would like a presentation about how the district is working to help failing students.
 Masel - Would like a presentation on block scheduling at Ball HS.

C) Board Committee Reports --8:07 pm Deferred.

- 1) Policy Committee Chair- Mr. David O'Neal
- 2) Curriculum Committee Chair- Ms. Monica Wagner
- 3) Facilities/Finance Committee Chair- Mr. Johnny Smecca

5) Financial Reports --8:09 pm **48**

Presented by Connie Morgenroth

Board questions from Smecca and Masel. Report continued by Morgenroth.

--8:20 pm Board comments about IVP. --8:40 Report continued by Morgenroth. --8:43

Deferred maintenance report by Paul Byers. --8:51 Board comments.

6) The Board may recess into Closed Executive Session in the Library as permitted by the Texas Open Meeting Act Government Code Sections 551.071- 551.090 Subchapter D and

E. --8:57 pm - **30**

Should any final action, final decision, or final vote be required in the opinion of the School Board with regard to any matter considered in such closed meeting then the final action, final decision, or final vote shall be either:

A) in the open meeting covered by the Notice upon the reconvening of the public meeting;
or

B) at a subsequent public meeting of the School Board upon notice thereof; as the School Board shall determine.

- A) Personnel
- B) Consultation with Attorney
- C) Real Property

7) Reestablish the open meeting of the Galveston ISD Board of Trustees. --9:27 pm

8) CONSENT AGENDA - Action Items **1**

Motion to approve the consent agenda (Item G withheld) by Ann Masel, Second by Monica Wagner. No discussion. Unanimous in favor.

- A) Consider approval of the minutes from the October 21, 2020 Regular Meeting.
- B) Consider approval of the Board's Time Use Tracker - October 21, 2020
- C) Discuss and consider approval of the Board's Quarterly Progress Tracker.
- D) Consider approval of personnel resignations and recommendations with contracts.
- E) Consider approval of November Budget Amendments
- F) Consider approval of Gifts and Donations.
- G) Consider approval of Purchases >\$50,000 *Deferred*
- H) Discuss and consider approval of payment of Attorney fees.
- I) Discuss and consider the approval for the Causeway Galveston program to apply for a grant from the MHA Center for School Behavioral Health. The amount of the award is \$100,000.
- J) Discuss and Consider for the 2020 2021 school year, delegating contractual authority to obligate the school district under Texas Education Code (TEC) 11.1511 to the superintendent, solely for the purpose of obligating the district under TEC, 48.257 and TEC, Chapter 49, Subchapters A and D, and the rules adopted by the commissioner of education as authorized under TEC, 49.006. This includes approval of the Agreement for the Purchase of Attendance Credit or the Agreement for the Purchase of Attendance Credit (Netting Chapter 48 Funding).
- K) Discuss and consider RFCSP Contract for HVAC Supplies and Services.
- L) Discuss and consider RFCSP Contract for Maintenance and Operating Supplies
- M) Discuss and consider approval of the contract with Adaptive Behavior School East (Harris County Department of Education) for a student in GISD.
- N) Discuss and Consider approval of deferred maintenance projects, not to exceed \$460,000 utilizing fund balance, as presented.
- O) Discuss and consider the approval for the Human Capital Management Department program to apply for the Texas Education Agency Mentor Program Allotment. The estimated amount of the award is \$108,000.
- P) Consider Secondary TEAL (Texas Education Agency Login) approver status for Lea Walker.

9) REGULAR AGENDA- Action Items --9:28 pm - **16**

A) Administer Oath of Office to Single-Member Districts 5-E and 6-F. --6:32 pm

B) Discuss and consider reorganization of Officers of the GISD Board of Trustees.--
9:28 pm

Ann Masel moved to keep the current officers. Second by David O’Neal. Board President, Tony Brown, Vice-President Johnny Smecca and Secretary Monica Wagner. Unanimous in favor.

C) Discuss and consider Purchase of Real Property --9:30 pm

Motion by Masel, 2nd Lakin to give Dr. Moulton authorization to negotiate on the district’s behalf for the purchase of real property. Unanimous in favor.

D) Discuss and consider approval of a Resolution to authorize compensation of employees for the days when the District is closed due to Coronavirus 19. --9:32 pm

Motion by Wagner, Second by Lakin --Unanimous in favor.

E) Discuss and consider approval of resolution adopting a temporary ad valorem tax exemption pursuant to Governor Greg Abbott’s disaster declaration and Texas Tax Code §11.35. --9:33 pm

Motion by Smecca, Second by Masel --Unanimous in favor.

F) Discuss and consider approval of resolution to commit fund balance. --9:35pm

Explanation by Connie Morgenroth

Motion by Masel to commit 11 million of the balance for disaster recovery, Second by Smecca -- Unanimous in favor.

10) Suggested Future Agenda Items

11) Board Comments --9:44 pm **21**

David O’Neal

--9:50 Shae Jobe

--9:51 Ann Masel

--9:51 Monica Wagner

--9:54 Mindy Lakin

--9:55 Johnny Smecca

--10:01 Tony Brown

12) Adjournment --10:05

Minutes taken by: Amedia Bly

Approved on: _____

Mr. Tony Brown, President

Mrs. Monica Wagner, Secretary

For the Board of Trustees

Action Sheet

MEETING DATE:

December 16, 2020

AGENDA ITEM:

Discuss and consider approval of personnel resignations and recommendations with contracts.

Under Separate Cover

RECOMMENDATION:

I move that the Board of Trustees approve personnel resignations and recommendations with contracts.

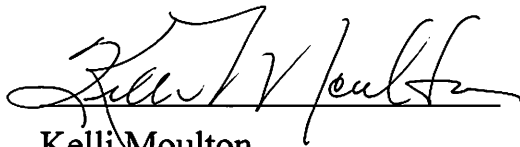

Kelli Moulton
Superintendent

Action Sheet

MEETING DATE:

December 16, 2020

AGENDA ITEM:

Consider approval of Monthly Budget Amendment (under separate cover).

RECOMMENDATION:

I move that the Board of Trustees approve the budget amendment as presented.

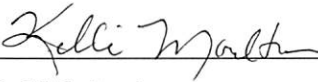

Kelli Moulton
Superintendent



Connie Morgenroth
Asst. Superintendent for Business and Operations

GALVESTON Independent School District
2020-2021 Proposed Budget Amendment
December 2020

Function	General Fund			Food Service Fund			Debt Service Fund		
	Beginning Budget	Amendments	Ending Budget	Beginning Budget	Amendments	Ending Budget	Beginning Budget	Amendments	Ending Budget
11 Instruction	\$ 38,122,655	\$ -	\$ 38,122,655	\$ -		\$ -	\$ -		\$ -
12 Instructional Resources	\$ 363,821	\$ -	\$ 363,821	\$ -		\$ -	\$ -		\$ -
13 Curriculum & Inst Staff Dev	\$ 807,761	\$ -	\$ 807,761	\$ -		\$ -	\$ -		\$ -
21 Instructional Leadership	\$ 1,717,159	\$ -	\$ 1,717,159	\$ -		\$ -	\$ -		\$ -
23 School Leadership	\$ 4,203,350	\$ -	\$ 4,203,350	\$ -		\$ -	\$ -		\$ -
31 Guidance/Counseling	\$ 1,991,893	\$ -	\$ 1,991,893	\$ -		\$ -	\$ -		\$ -
32 Social Work Services	\$ 282,584	\$ -	\$ 282,584	\$ -		\$ -	\$ -		\$ -
33 Health Services	\$ 1,023,271	\$ -	\$ 1,023,271	\$ -		\$ -	\$ -		\$ -
34 Student Transportation	\$ 3,151,129	\$ -	\$ 3,151,129	\$ -		\$ -	\$ -		\$ -
35 Food Services	\$ -	\$ -	\$ -	\$ 3,902,077		\$ 3,902,077	\$ -		\$ -
36 Extracurricular Activities	\$ 1,872,782	\$ -	\$ 1,872,782	\$ -		\$ -	\$ -		\$ -
41 General Administration	\$ 2,754,019	\$ -	\$ 2,754,019	\$ -		\$ -	\$ -		\$ -
51 Maintenance and Operations	\$ 10,223,553	\$ 78,959	\$ 10,302,512	\$ 394,430		\$ 394,430	\$ -		\$ -
52 Security and Monitoring	\$ 1,162,092	\$ -	\$ 1,162,092	\$ -		\$ -	\$ -		\$ -
53 Data Processing Services	\$ 2,115,293	\$ -	\$ 2,115,293	\$ -		\$ -	\$ -		\$ -
61 Community Services	\$ 701,792	\$ -	\$ 701,792	\$ -		\$ -	\$ -		\$ -
71 Debt Service	\$ -	\$ -	\$ -	\$ -		\$ -	\$ 7,897,200		\$ 7,897,200
81 Construction	\$ 460,000	\$ -	\$ 460,000	\$ -		\$ -	\$ -		\$ -
93 Shared Services	\$ 21,393,538	\$ -	\$ 21,393,538	\$ -		\$ -	\$ -		\$ -
95 JJAEP	\$ 60,000	\$ -	\$ 60,000	\$ -		\$ -	\$ -		\$ -
99 Intergovernmental Charges	\$ 689,067	\$ -	\$ 689,067	\$ -		\$ -	\$ -		\$ -
8911 Transfers Out	\$ -	\$ -	\$ -	\$ -		\$ -	\$ -		\$ -
TOTAL	\$ 93,095,759	\$ 78,959	\$ 93,174,718	\$ 4,296,507	\$ -	\$ 4,296,507	\$ 7,897,200	\$ -	\$ 7,897,200

Function	Explanation
51	78,959.00 PURCHASE OF BOX TRUCK
TOTAL	78,959.00

** Indicates offsetting revenues will also be recorded totaling*

Recap of Budget Increase:
78,959.00 PURCHASE OF BOX TRUCK
\$ 78,959.00 Total Increase

Action Sheet

MEETING DATE: December 16, 2020

AGENDA ITEM: Discuss and consider approval of purchases > \$50,000.

1. Consider purchase of elementary furniture, not to exceed \$115,000.
2. Consider purchase of box truck, not to exceed \$80,000.
3. Consider purchase of wireless access points and controller, not to exceed \$90,122.40.

RECOMMENDATION: I move the board approve the purchases \geq \$50,000, as presented.

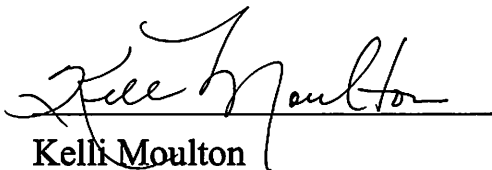
Kelli Moulton
Superintendent

Connie Morgenroth
Assistant Superintendent of Business & Operations

1. CLASSROOM FURNITURE PURCHASE – Estimated Cost \$113,267 (using bond funds)

The following 5 campus Principals have requested elementary school furniture for the following (mostly) COVID-19 related reasons:

- a. Social distance requirements
- b. Instructional control
- c. Individual work spaces
- d. Replacement of broken equipment
- e. Work group configuration
- f. Continued standardization of equipment

La. Morgan – 110 desks; 110 chairs
Kinder 20; 1st 25; 2nd 25; 3rd 20; 4th 20
Parker – 140 desks; 140 chairs
Pre-K 40; Kinder 100
Rosenberg – 110 desks; 110 desk
1st 66; 2nd 44
Burnet – 396 desks; 396 chairs
Pre-k 88; Kinder 110; 1st 66; 2nd 30; 3rd
38; 4th 42; Fine Arts 22

Oppe – 160 desks; 160 chairs
Pre-k 40; Kinder 120
Total – 916 desks; 916 chairs
BuyBoard Contract #584-19 Indeco Sales

Total Cost: \$113,266.80

2. PURCHASE OF BOX TRUCK – Estimated Cost \$78,959 (using general funds)

Over the past ten years, the high school band program has grown considerably. In addition, the board has purchased additional band equipment for the program. Besides utilizing our big box truck, we've been renting one Penske truck each year, at a cost of approximately \$8,000 for 12 weeks, to transport band equipment to the football games.

After looking into various options, we would like to ask the Board to consider the purchase of another box truck that could be used for this purpose and many others. We believe that purchasing another box truck makes economic sense. We estimate the useful life of the truck to be 15 years, so we would break even in 10 years, and would have the use of the truck all year long vs. only 3 months per year. The additional truck would be used for deliveries, and moving equipment and furniture around the District. Mr. Byers believes this truck would be utilized almost every day. The District obtained 3 cooperative quotes, and the best price was \$78,959 from Chastang Ford for a 2021 750 26' diesel box truck, under BuyBoard Contract #601-19.

3. PURCHASE OF WIRELESS CONTROLLER AND ACCESS POINTS – Estimated Cost \$90,122 (general fund \$17,563 and Erate funding \$72,559.40)

The CISCO controller that serves wireless access points throughout the District failed recently; therefore, the District must replace it. This will require upgrading access points at Oppe and Parker, as some of their access points are outdated and will not work with the updated controller.

This project qualifies for Erate (Federal) funding. MicroIntegration is the approved Erate vendor for this purchase. Their quote for the Wireless Access points for Oppe and Parker and the Cisco Controller is \$90,122.40, of which \$72,559.40 has been approved by USAC for Erate reimbursement. According to the District's Erate consultant, MicroIntegration will bill Schools and Library directly for the portion approved by USAC. The district will be responsible for the balance (\$17,563) to come from the technology budget in the general fund. We are asking the board to approve the entire purchase of \$90,122.40 with the understanding that if MicroIntegration cannot bill USAC directly, the District will need to fund the entire purchase amount and apply for Erate reimbursement.

Galveston Independent School District
Elementary School Furniture Request
December 2, 2020

Request for elementary school furniture from the principal's below are related to

- a. Covid-19 social distance requirements
- b. instructional control
- c. individual work spaces
- d. replacement of broken equipment
- e. work group configuration
- f. continued standardization of equipment



La. Morgan – 110 desk; 110 chairs

Kinder 20; 1st 25; 2nd 25; 3rd 20; 4th 20

Parker – 140 desk; 140 chairs

Pre-K 40; Kinder 100

Rosenberg – 110 desk; 110 desk

1st 66; 2nd 44

Burnet – 396 desk; 396 chairs

Pre-k 88; Kinder 110; 1st 66; 2nd 30; 3rd 38; 4th 42; Fine Arts 22

Oppe – 160 desk; 160 chairs

Pre-k 40; Kinder 120

Total – 916 desk; 916 chairs

Buy Board Contract #584-19 Indeco Sales

Total Value - \$113,266.80

Indeco

K-12 Done Right

805 East 4th Avenue • Belton, Texas 76513
800.692.4256 • info@indecosales.com

PROPOSAL

DATE	PROPOSAL#
11/28/20	11561

VALID THROUGH: / /
PROJECT#: 13-838

CUSTOMER: Galveston ISD PO BOX 660 GALVESTON TX 77553 PH# (409) 766-5100

INSTALL AT: Facilities Department and Central Receiving 4302 AVE Q GALVESTON TX 77550

CUSTOMER P.O.# SALESPERSON TERMS SHIP VIA

David Fitzmorris Net 30

#	QTY	PRODUCT	DESCRIPTION	SELL EACH	SELL EXTEND
1	140	7SD4A63.P1	ARTCO BELL CORP 7SD Series, 4L 22"-30" ADJ, 20X26, Lam-Clear Edge, with Poly Bookbox Nylon Chrome Bannister Oak TAG #1: Parker	91.71	12,839.40
2	110	7SD4A63.P1	ARTCO BELL CORP 7SD Series, 4L 22"-30" ADJ, 20X26, Lam-Clear Edge, with Poly Bookbox Nylon Chrome Bannister Oak TAG #1: Rosenberg	91.71	10,088.10
3	110	7SD4A63.P1	ARTCO BELL CORP 7SD Series, 4L 22"-30" ADJ, 20X26, Lam-Clear Edge, with Poly Bookbox Nylon Chrome Bannister Oak TAG #1: La Morgan	91.71	10,088.10
4	396	7SD4A63.P1	ARTCO BELL CORP 7SD Series, 4L 22"-30" ADJ, 20X26, Lam-Clear Edge, with Poly Bookbox Nylon Chrome Bannister Oak TAG #1: Burnet	91.71	36,317.16
5	160	7SD4A63.P1	ARTCO BELL CORP 7SD Series, 4L 22"-30" ADJ, 20X26, Lam-Clear Edge, with Poly Bookbox Nylon Chrome Bannister Oak CONTINUED...	91.71	14,673.60

Indeco

K-12 Done Right

805 East 4th Avenue • Belton, Texas 76513
800.692.4256 • info@indecosales.com

P R O P O S A L

DATE	PROPOSAL#
11/28/20	11561

VALID THROUGH: / /
PROJECT#: 13-838

CUSTOMER: Galveston ISD PO BOX 660 GALVESTON TX 77553 PH# (409) 766-5100
--

INSTALL AT: Facilities Department and Central Receiving 4302 AVE Q GALVESTON TX 77550
--

CUSTOMER P.O.# SALESPERSON TERMS SHIP VIA

David Fitzmorris Net 30

#	QTY	PRODUCT	DESCRIPTION	SELL EACH	SELL EXTEND
			TAG #1: Oppe		
6	774	7105	ARTCO BELL CORP Uniflex, 4L Chair, 15.5" Nylon Chrome Navy Indigo	31.86	24,659.64
7	142	7107	ARTCO BELL CORP Uniflex, 4L Chair, 17.5" Nylon Chrome Navy Indigo	32.40	4,600.80
Buyboard Contract 584-19					
					PRODUCT 113,266.80
ACCEPTED BY _____					
DATE ACCEPTED _____					
113					=====
TOTAL					113,266.80



To: Connie Morgenroth, Asst. Superintendent Business & Operations

From: Gwynetheia Shabazz Pope

CC: April Pinkham, Finance Director
John Pruitt, Transportation Director

Date: 12/8/2020

Re: Request for Quote (Informal) 2021 F-750 Diesel Regular Cab Box Truck
Evaluation and Award Recommendation

Enclosed for your review and approval is the award recommendation for quotes obtained on the purchase of a 2021 F-750 Diesel Regular Cab Box Truck.

HISTORY

The objective of the Request for Quotes was to obtain a cost comparison on the truck the District is interested in purchasing. We reached out to three vendors to ensure we were guaranteed the best price and best value for GISD. The quotes are attached.

Chastang Ford \$78,959.00	Buyboard contract 601-19 Vehicles, Heavy Duty Trucks
Grande Truck Center \$82,360.00	Buyboard contract 601-19 Vehicles, Heavy Duty Trucks
Rush Truck Center \$88,402.52	Buyboard contract 601-19 Vehicles, Heavy Duty Trucks

AWARD RECOMMENDATION

The Purchasing Department recommends awarding the contract to Chastang Ford in the amount of \$ 78,959.00 (plus the 800.00 fee to Buyboard) as the Best Value to the District.

Gwynetheia Shabazz Pope, CTPM, CTCM
Purchasing Coordinator

Gwynetheia Shabazz Pope

Gwynetheia V. Pope, CTPM, CTCM
Purchasing Coordinator
gwynetheiapope@gisd.org

3904 Avenue T.
Galveston, TX 77550
www.gisd.org

Main: 409.766.5100
Direct: 409.766.5158
Fax: 409.762.8841

2021 F-750 Diesel Regular Cab Base (F7D)

Price Level: 120

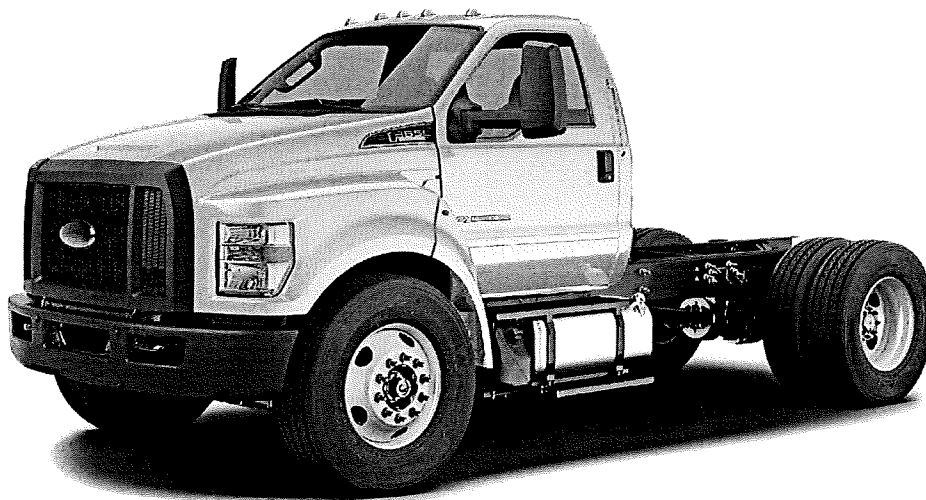

Client Proposal

Prepared by:

Ed Miller

Office: 713-678-5007

Email: EMILLER@CHASTANGFORD.COM

Quote ID: GALSD21F7D

Date: 09/18/2020





Prepared by: Ed Miller
09/18/2020

Chastang Ford | 6200 N. Loop East Houston Texas | 770261936

2021 F-750 Diesel Regular Cab Base (F7D)

Price Level: 120 | Quote ID: GALSD21F7D

As Configured Vehicle

Code	Description	MSRP
Base Vehicle		
F7D	Base Vehicle Price (F7D)	\$70,945.00
Engines		
99C	6.7L Power Stroke V8 Turbo Diesel - 270 HP @ 2400 RPM Includes Engine Exhaust Brake and manual regen capability. Torque: 700 ft.lbs. @ 1500 rpm. <i>Governed RPM: 3200. Includes CARB clean idle label - may be removed if un-necessary.</i>	STD
425	50-State Emissions	N/C
41H	Engine Block Heater, Phillips, 120 Volt/750 Watt	\$60.00
Transmissions		
44G	Ford TorqShift HD 6-Speed Automatic - Double Overdrive, less PTO Provision, less Park Pawl	STD
41A	Transmission Power Take-Off Provision w/LiveDrive Capability and Tow/Haul	\$895.00
Front Wheels & Tires		
643	Wheels, Front 22.5x8.25 White Powder Coated Steel, 10-Hole <i>(285.75MM BC) hub piloted, flanged nut, metric mount, 8.25 DC rims; with steel hubs.</i>	STD
T2B	Tires, Front Two 11R22.5G Goodyear Fuel Max RSA (497 rev/mile)	STD
Rear Wheels & Tires		
663	Wheels, Rear 22.5x8.25 White Powder Coated Steel, 10-Hole <i>(285.75MM BC) hub piloted, flanged nut, metric mount, 8.25 DC rims; with steel hubs.</i>	STD

Prices and content availability as shown are subject to change and should be treated as estimates only. Actual base vehicle, package and option pricing may vary from this estimate because of special local pricing, availability or pricing adjustments not reflected in the dealer's computer system. See salesperson for the most current information.

Note: Prices and content availability as shown are subject to change and should be treated as estimates only. Actual base vehicle, package and option pricing may vary from this estimate because of special local pricing, availability or pricing adjustments not reflected in the dealer's computer system. See salesperson for the most current information.



Prepared by: Ed Miller
09/18/2020

Chastang Ford | 6200 N. Loop East Houston Texas | 770261936

2021 F-750 Diesel Regular Cab Base (F7D)

Price Level: 120 | Quote ID: GALSD21F7D

As Configured Vehicle (cont'd)

Code	Description	MSRP
R2B	Tires, Rear Four 11R22.5G Goodyear Fuel Max RSA (497 rev/mile)	STD
Brakes		
67H	Hydraulic Brake System - Bosch HydroMax w/Traction Control <i>Full power with automatic adjustment, 4-channel ABS antilock brake system. Includes 12" x 3" (Bosch) DSSA type rear axle mounted parking brake. Orscheln lever control, right of driver.</i>	STD
Front Axle and Suspension		
43N	10,000 lb. Cap. Non-Driving - Dana E-1002I - I-Beam Type	STD
61C	Taper-Leaf Springs, Parabolic - 10,000 lb. Cap <i>2-leaf, 62" x 3.15". Also includes, standard duty, dual, double acting shock absorbers.</i>	STD
Rear Axle and Suspension		
475	21,000 lb. Single Reduction - Open - Dana / Spicer 21060S <i>NOTE: When specifying an axle ratio, check performance guidelines for startability and gradeability.</i>	STD
18P	Driveshaft Upgrade <i>A heavy duty drive line is optional. Heavy duty drive line components are required in more demanding applications, such as higher torque engines or deep reduction low gear(s). The heavier SPL-140 driveshaft is powertrain dependent and should be used when more durability is required by the vocation or customer.</i>	\$185.00
68R	Multi-Leaf Springs - 23,000 lb. Cap <i>11-leaf. Includes 2,000 lb auxiliary springs for load stabilization.</i>	\$230.00
X6B	6.17 Axle Ratio	N/C
Wheelbase		
260WB	260" Wheelbase/186" CA/120" AF/419" OAL	\$965.00

Frame

Prices and content availability as shown are subject to change and should be treated as estimates only. Actual base vehicle, package and option pricing may vary from this estimate because of special local pricing, availability or pricing adjustments not reflected in the dealer's computer system. See salesperson for the most current information.

Note: Prices and content availability as shown are subject to change and should be treated as estimates only. Actual base vehicle, package and option pricing may vary from this estimate because of special local pricing, availability or pricing adjustments not reflected in the dealer's computer system. See salesperson for the most current information.



Prepared by: Ed Miller
09/18/2020

Chastang Ford | 6200 N. Loop East Houston Texas | 770261936

2021 F-750 Diesel Regular Cab Base (F7D)

Price Level: 120 | Quote ID: GALSD21F7D

As Configured Vehicle (cont'd)

Code	Description	MSRP
535	Single Channel - Straight 'C' 15.14 SM, 80,000 PSI <i>1,211,200 RBM. High strength low alloy steel. 10.250" x 3.092" x 0.375" (260.4mm x 78.5mm x 9.5mm).</i>	STD
18D	Special Rating GVWR - Limited to 25,999 lb. GVWR	\$120.00
Exhaust		
91G	Under Cab, Right Side Outlet, Switchback-Style <i>Single, horizontal muffler, right side, under cab, outside of frame rail with rear discharge.</i>	STD
Fuel Tanks		
65B	Fuel Tank - LH 50 Gallon Rectangular - Aluminum	STD
12	12 Gal. Single Tank Fuel Fill. Mandatory Charge Applied, Based On Tank Selection	\$0.00
Electrical / Alternator / Battery		
STDALT	Extra Heavy Duty Alternator - 12-Volt, 200 Amp Denso SC5	Included
55M	Jump Start Stud - Remote Mounted	\$90.00
STDBAT	Battery - Two 750 CCA, 1500 Total, Includes Steel Battery Box <i>12Volt, Motorcraft.</i>	STD
962	Daytime Running Lamps	\$45.00
16V	Voltmeter <i>Available in message center.</i>	\$100.00

Seats

Prices and content availability as shown are subject to change and should be treated as estimates only. Actual base vehicle, package and option pricing may vary from this estimate because of special local pricing, availability or pricing adjustments not reflected in the dealer's computer system. See salesperson for the most current information.

Note: Prices and content availability as shown are subject to change and should be treated as estimates only. Actual base vehicle, package and option pricing may vary from this estimate because of special local pricing, availability or pricing adjustments not reflected in the dealer's computer system. See salesperson for the most current information.



Prepared by: Ed Miller
09/18/2020

Chastang Ford | 6200 N. Loop East Houston Texas | 770261936

2021 F-750 Diesel Regular Cab Base (F7D)

Price Level: 120 | Quote ID: GALSD21F7D

As Configured Vehicle (cont'd)

Code	Description	MSRP
88L	30/70 Air Ride Driver (Integral Air Pump) & Fixed 2-Passenger Bench - Vinyl	\$440.00
Cab Interior		
600A	Preferred Equipment Package 600A <i>Includes:</i> - Bumper, Front - Black, Full Width - Wheel Seals, Front - Oil lubricated, SKF ScotSeal PlusXL Seals - Wheel Seals, Rear - Oil lubricated, SKF ScotSeal PlusXL Seals - Manual Regen Initiation - Driver Interface in Message Center - Engine Exhaust Brake - Extra Heavy Duty Alternator - 12-Volt, 200 Amp Denso SC5 - Painted Grille - Plastic - Lights - Roof Marker/Clearance - Amber Lenses, 5 Lights - Tow Hooks, Front (2) - Frame-Mounted, Painted Black - Four Body Builder Switches - Mounted in Center Instrument Panel <i>With connector access located in engine compartment. Amperages vary by switch: 10, 15, 25, 25.</i> - Floor Covering - Black Vinyl - Intelligent Oil Life Monitor - Steering Column - Tilt / Telescoping - Steering Wheel - Black PVC w/Integral Cruise Control Switches, includes Audio Controls - Body Builder Wiring - At Back of Cab, Combined <i>Includes sealed connectors for 2 ground circuits, with combined left/stop, combined right/stop, park lamps, back up lamps. Also includes 2 additional pass through wires to cab.</i>	N/C
90P	Power Equipment Group - (Included in (90A) Appearance Group) <i>Includes power front side windows, power door locks and door trim panel.</i>	\$470.00
588	Radio: AM/FM Stereo w/2 Speakers, USB input, Clock Display and Bluetooth	STD
Cab Exterior		
54C	Mirrors, Dual - Heated Rectangular, XL2020 - 102" Width <i>Integral spot mirror, sail type, manual fold, solid black finish.</i>	\$90.00
165	Mud Flap Holder Without Flaps	\$95.00
Miscellaneous		
PAINT	Paint Type - Environmentally Friendly, "3 - Wet System"	STD

Interior Colors

Prices and content availability as shown are subject to change and should be treated as estimates only. Actual base vehicle, package and option pricing may vary from this estimate because of special local pricing, availability or pricing adjustments not reflected in the dealer's computer system. See salesperson for the most current information.

Note: Prices and content availability as shown are subject to change and should be treated as estimates only. Actual base vehicle, package and option pricing may vary from this estimate because of special local pricing, availability or pricing adjustments not reflected in the dealer's computer system. See salesperson for the most current information.



Prepared by: Ed Miller
09/18/2020

Chastang Ford | 6200 N. Loop East Houston Texas | 770261936

2021 F-750 Diesel Regular Cab Base (F7D)

Price Level: 120 | Quote ID: GALSD21F7D

As Configured Vehicle (cont'd)

Code	Description	MSRP
E_01	Gray	N/C
Primary Colors		
YZ_01	Oxford White	N/C
Upfit Options		
60-140	INSTALL 2500 LBTOMMY GATE RAIL LIFT GATE	\$6,995.00
Buy Board	Buy Board Fee <i>CONTRACT 601-19</i>	\$400.00
24 VAN	INSTALL A 24 FOOT VAN BODY	\$11,785.00
SUBTOTAL		\$93,910.00
Destination Charge		\$2,095.00
TOTAL		\$96,005.00

Prices and content availability as shown are subject to change and should be treated as estimates only. Actual base vehicle, package and option pricing may vary from this estimate because of special local pricing, availability or pricing adjustments not reflected in the dealer's computer system. See salesperson for the most current information.

Note: Prices and content availability as shown are subject to change and should be treated as estimates only. Actual base vehicle, package and option pricing may vary from this estimate because of special local pricing, availability or pricing adjustments not reflected in the dealer's computer system. See salesperson for the most current information.



Prepared by: Ed Miller
09/18/2020

Chastang Ford | 6200 N. Loop East Houston Texas | 770261936

2021 F-750 Diesel Regular Cab Base (F7D)

Price Level: 120 | Quote ID: GALSD21F7D

Pricing Summary - Single Vehicle

MSRP

Vehicle Pricing

Base Vehicle Price	\$70,945.00
Options & Colors	\$3,785.00
Upfitting	\$19,180.00
Destination Charge	\$2,095.00
Subtotal	\$96,005.00

Pre-Tax Adjustments

Code	Description	
01 ft	DISCOUNT AND CONCESSION	-\$17,046.00
Total		\$78,959.00

Customer Signature

Acceptance Date

Prices and content availability as shown are subject to change and should be treated as estimates only. Actual base vehicle, package and option pricing may vary from this estimate because of special local pricing, availability or pricing adjustments not reflected in the dealer's computer system. See salesperson for the most current information.

Note: Prices and content availability as shown are subject to change and should be treated as estimates only. Actual base vehicle, package and option pricing may vary from this estimate because of special local pricing, availability or pricing adjustments not reflected in the dealer's computer system. See salesperson for the most current information.



Prepared by: Ed Miller
09/18/2020

Chastang Ford | 6200 N. Loop East Houston Texas | 770261936

2021 F-750 Diesel Regular Cab Base (F7D)

Price Level: 120 | Quote ID: GALSD21F7D

Vehicle Dimension and Performance Summary

Performance predictions in this report represent an estimate of vehicle performance based on standard operating conditions. Variations in customer equipment, load configuration, ambient conditions, and/or operator driving techniques can cause significant variations in vehicle performance. These values are not representative of results that may be shown in actual dynamometer tests. This report should therefore be used as a guide for comparative vehicle performance.

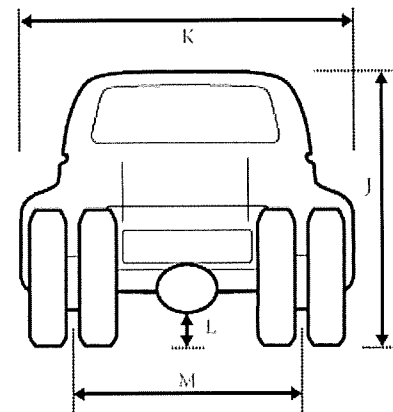
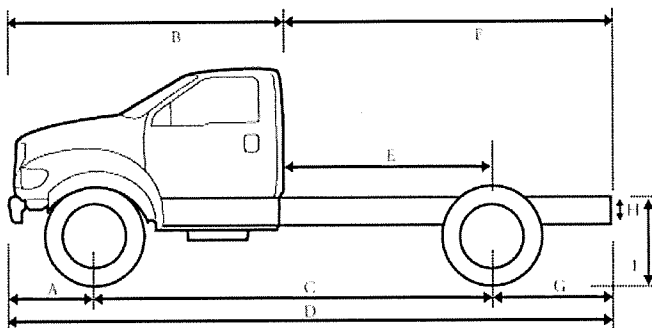

Dimensions

A	Front of Bumper to Front Axle	39.00 in.
B	Front Bumper to Back of Cab (BBC)	113.00 in.
C	Wheelbase (WB)	260.00 in.
D	Overall Length (OAL)	419.00 in.
E	Back of Cab to Rear Axle (CA)	186.00 in.
F	Back of Cab to End of Frame	306.00 in.
G	Rear Axle to End of Frame (AF)	120.00 in.
H	Frame Section Height	10.30 in.
I	Rear Frame Height Unloaded	38.20 in.
I	Rear Frame Height Loaded	36.80 in.
J	Cab Height	94.30 in.
K	Body Width	96.70 in.
L	Maximum Ground Clearance	N/A
L	Minimum Ground Clearance	N/A
M	Front Tread	83.80 in.
M	Rear Tread	72.60 in.

Prices and content availability as shown are subject to change and should be treated as estimates only. Actual base vehicle, package and option pricing may vary from this estimate because of special local pricing, availability or pricing adjustments not reflected in the dealer's computer system. See salesperson for the most current information.

Note: Prices and content availability as shown are subject to change and should be treated as estimates only. Actual base vehicle, package and option pricing may vary from this estimate because of special local pricing, availability or pricing adjustments not reflected in the dealer's computer system. See salesperson for the most current information.

2021 F-750 Diesel Regular Cab Base (F7D)

Price Level: 120

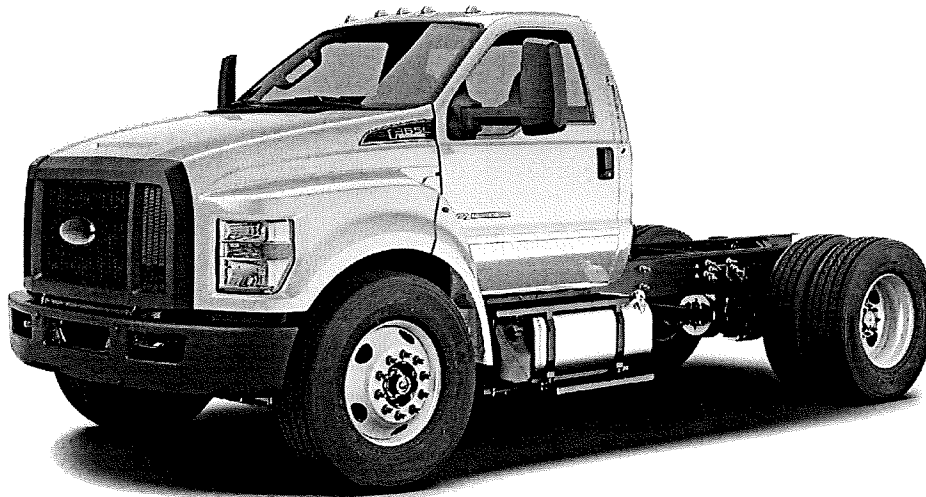

Client Proposal

Prepared by:

Ed Miller

Office: 713-678-5007

Email: EMILLER@CHASTANGFORD.COM

Quote ID: GALSD21F7D

Date: 09/18/2020



Chastang Ford | 6200 N. Loop East, Houston, Texas, 770261936

Office: 713-678-5000 | Fax: 713-678-5001



Prepared by: Ed Miller
09/18/2020

Chastang Ford | 6200 N. Loop East Houston Texas | 770261936

2021 F-750 Diesel Regular Cab Base (F7D)

Price Level: 120 | Quote ID: GALSD21F7D

As Configured Vehicle

Code	Description	MSRP
Base Vehicle		
F7D	Base Vehicle Price (F7D)	\$70,945.00
Engines		
99C	6.7L Power Stroke V8 Turbo Diesel - 270 HP @ 2400 RPM Includes Engine Exhaust Brake and manual regen capability. Torque: 700 ft.lbs. @ 1500 rpm. <i>Governed RPM: 3200. Includes CARB clean idle label - may be removed if un-necessary.</i>	STD
425	50-State Emissions	N/C
41H	Engine Block Heater, Phillips, 120 Volt/750 Watt	\$60.00
Transmissions		
44G	Ford TorqShift HD 6-Speed Automatic - Double Overdrive, less PTO Provision, less Park Pawl	STD
41A	Transmission Power Take-Off Provision w/LiveDrive Capability and Tow/Haul	\$895.00
Front Wheels & Tires		
643	Wheels, Front 22.5x8.25 White Powder Coated Steel, 10-Hole <i>(285.75MM BC) hub piloted, flanged nut, metric mount, 8.25 DC rims; with steel hubs.</i>	STD
T2B	Tires, Front Two 11R22.5G Goodyear Fuel Max RSA (497 rev/mile)	STD
Rear Wheels & Tires		
663	Wheels, Rear 22.5x8.25 White Powder Coated Steel, 10-Hole <i>(285.75MM BC) hub piloted, flanged nut, metric mount, 8.25 DC rims; with steel hubs.</i>	STD

Prices and content availability as shown are subject to change and should be treated as estimates only. Actual base vehicle, package and option pricing may vary from this estimate because of special local pricing, availability or pricing adjustments not reflected in the dealer's computer system. See salesperson for the most current information.

Note: Prices and content availability as shown are subject to change and should be treated as estimates only. Actual base vehicle, package and option pricing may vary from this estimate because of special local pricing, availability or pricing adjustments not reflected in the dealer's computer system. See salesperson for the most current information.



Prepared by: Ed Miller
09/18/2020

Chastang Ford | 6200 N. Loop East Houston Texas | 770261936

2021 F-750 Diesel Regular Cab Base (F7D)

Price Level: 120 | Quote ID: GALSD21F7D

As Configured Vehicle (cont'd)

Code	Description	MSRP
R2B	Tires, Rear Four 11R22.5G Goodyear Fuel Max RSA (497 rev/mile)	STD
Brakes		
67H	Hydraulic Brake System - Bosch HydroMax w/Traction Control <i>Full power with automatic adjustment, 4-channel ABS antilock brake system. Includes 12" x 3" (Bosch) DSSA type rear axle mounted parking brake. Orscheln lever control, right of driver.</i>	STD
Front Axle and Suspension		
43N	10,000 lb. Cap. Non-Driving - Dana E-1002I - I-Beam Type	STD
61C	Taper-Leaf Springs, Parabolic - 10,000 lb. Cap <i>2-leaf, 62" x 3.15". Also includes, standard duty, dual, double acting shock absorbers.</i>	STD
Rear Axle and Suspension		
475	21,000 lb. Single Reduction - Open - Dana / Spicer 21060S <i>NOTE: When specifying an axle ratio, check performance guidelines for startability and gradeability.</i>	STD
18P	Driveshaft Upgrade <i>A heavy duty drive line is optional. Heavy duty drive line components are required in more demanding applications, such as higher torque engines or deep reduction low gear(s). The heavier SPL-140 driveshaft is powertrain dependent and should be used when more durability is required by the vocation or customer.</i>	\$185.00
68R	Multi-Leaf Springs - 23,000 lb. Cap <i>11-leaf. Includes 2,000 lb auxiliary springs for load stabilization.</i>	\$230.00
X6B	6.17 Axle Ratio	N/C
Wheelbase		
260WB	260" Wheelbase/186" CA/120" AF/419" OAL	\$965.00

Frame

Prices and content availability as shown are subject to change and should be treated as estimates only. Actual base vehicle, package and option pricing may vary from this estimate because of special local pricing, availability or pricing adjustments not reflected in the dealer's computer system. See salesperson for the most current information.

Note: Prices and content availability as shown are subject to change and should be treated as estimates only. Actual base vehicle, package and option pricing may vary from this estimate because of special local pricing, availability or pricing adjustments not reflected in the dealer's computer system. See salesperson for the most current information.



Prepared by: Ed Miller
09/18/2020

Chastang Ford | 6200 N. Loop East Houston Texas | 770261936

2021 F-750 Diesel Regular Cab Base (F7D)

Price Level: 120 | Quote ID: GALSD21F7D

As Configured Vehicle (cont'd)

Code	Description	MSRP
535	Single Channel - Straight 'C' 15.14 SM, 80,000 PSI <i>1,211,200 RBM. High strength low alloy steel. 10.250" x 3.092" x 0.375" (260.4mm x 78.5mm x 9.5mm).</i>	STD
18D	Special Rating GVWR - Limited to 25,999 lb. GVWR	\$120.00
Exhaust		
91G	Under Cab, Right Side Outlet, Switchback-Style <i>Single, horizontal muffler, right side, under cab, outside of frame rail with rear discharge.</i>	STD
Fuel Tanks		
65B	Fuel Tank - LH 50 Gallon Rectangular - Aluminum	STD
12	12 Gal. Single Tank Fuel Fill. Mandatory Charge Applied, Based On Tank Selection	\$0.00
Electrical / Alternator / Battery		
STDALT	Extra Heavy Duty Alternator - 12-Volt, 200 Amp Denso SC5	Included
55M	Jump Start Stud - Remote Mounted	\$90.00
STDBAT	Battery - Two 750 CCA, 1500 Total, Includes Steel Battery Box <i>12Volt, Motorcraft.</i>	STD
962	Daytime Running Lamps	\$45.00
16V	Voltmeter <i>Available in message center.</i>	\$100.00
Seats		

Prices and content availability as shown are subject to change and should be treated as estimates only. Actual base vehicle, package and option pricing may vary from this estimate because of special local pricing, availability or pricing adjustments not reflected in the dealer's computer system. See salesperson for the most current information.

Note: Prices and content availability as shown are subject to change and should be treated as estimates only. Actual base vehicle, package and option pricing may vary from this estimate because of special local pricing, availability or pricing adjustments not reflected in the dealer's computer system. See salesperson for the most current information.



Prepared by: Ed Miller
09/18/2020

Chastang Ford | 6200 N. Loop East Houston Texas | 770261936

2021 F-750 Diesel Regular Cab Base (F7D)

Price Level: 120 | Quote ID: GALSD21F7D

As Configured Vehicle (cont'd)

Code	Description	MSRP
88L	30/70 Air Ride Driver (Integral Air Pump) & Fixed 2-Passenger Bench - Vinyl	\$440.00
Cab Interior		
600A	Preferred Equipment Package 600A <i>Includes:</i> - Bumper, Front - Black, Full Width - Wheel Seals, Front - Oil lubricated, SKF ScotSeal PlusXL Seals - Wheel Seals, Rear - Oil lubricated, SKF ScotSeal PlusXL Seals - Manual Regen Initiation - Driver Interface in Message Center - Engine Exhaust Brake - Extra Heavy Duty Alternator - 12-Volt, 200 Amp Denso SC5 - Painted Grille - Plastic - Lights - Roof Marker/Clearance - Amber Lenses, 5 Lights - Tow Hooks, Front (2) - Frame-Mounted, Painted Black - Four Body Builder Switches - Mounted in Center Instrument Panel <i>With connector access located in engine compartment. Amperages vary by switch: 10, 15, 25, 25.</i> - Floor Covering - Black Vinyl - Intelligent Oil Life Monitor - Steering Column - Tilt / Telescoping - Steering Wheel - Black PVC w/Integral Cruise Control Switches, includes Audio Controls - Body Builder Wiring - At Back of Cab, Combined <i>Includes sealed connectors for 2 ground circuits, with combined left/stop, combined right/stop, park lamps, back up lamps. Also includes 2 additional pass through wires to cab.</i>	N/C
90P	Power Equipment Group - (Included in (90A) Appearance Group) <i>Includes power front side windows, power door locks and door trim panel.</i>	\$470.00
588	Radio: AM/FM Stereo w/2 Speakers, USB input, Clock Display and Bluetooth	STD
Cab Exterior		
54C	Mirrors, Dual - Heated Rectangular, XL2020 - 102" Width <i>Integral spot mirror, sail type, manual fold, solid black finish.</i>	\$90.00
165	Mud Flap Holder Without Flaps	\$95.00
Miscellaneous		
PAINT	Paint Type - Environmentally Friendly, "3 - Wet System"	STD

Interior Colors

Prices and content availability as shown are subject to change and should be treated as estimates only. Actual base vehicle, package and option pricing may vary from this estimate because of special local pricing, availability or pricing adjustments not reflected in the dealer's computer system. See salesperson for the most current information.

Note: Prices and content availability as shown are subject to change and should be treated as estimates only. Actual base vehicle, package and option pricing may vary from this estimate because of special local pricing, availability or pricing adjustments not reflected in the dealer's computer system. See salesperson for the most current information.



Prepared by: Ed Miller
09/18/2020

Chastang Ford | 6200 N. Loop East Houston Texas | 770261936

2021 F-750 Diesel Regular Cab Base (F7D)

Price Level: 120 | Quote ID: GALSD21F7D

As Configured Vehicle (cont'd)

Code	Description	MSRP
E_01	Gray	N/C
Primary Colors		
YZ_01	Oxford White	N/C
Upfit Options		
60-140	INSTALL 2500 LBTOMMY GATE RAIL LIFT GATE	\$6,995.00
Buy Board	Buy Board Fee <i>CONTRACT 601-19</i>	\$400.00
24 VAN	INSTALL A 24 FOOT VAN BODY	\$11,785.00
SUBTOTAL		\$93,910.00
Destination Charge		\$2,095.00
TOTAL		\$96,005.00

Prices and content availability as shown are subject to change and should be treated as estimates only. Actual base vehicle, package and option pricing may vary from this estimate because of special local pricing, availability or pricing adjustments not reflected in the dealer's computer system. See salesperson for the most current information.

Note: Prices and content availability as shown are subject to change and should be treated as estimates only. Actual base vehicle, package and option pricing may vary from this estimate because of special local pricing, availability or pricing adjustments not reflected in the dealer's computer system. See salesperson for the most current information.



Prepared by: Ed Miller
09/18/2020

Chastang Ford | 6200 N. Loop East Houston Texas | 770261936

2021 F-750 Diesel Regular Cab Base (F7D)

Price Level: 120 | Quote ID: GALSD21F7D

Pricing Summary - Single Vehicle

MSRP

Vehicle Pricing

Base Vehicle Price	\$70,945.00
Options & Colors	\$3,785.00
Upfitting	\$19,180.00
Destination Charge	\$2,095.00
Subtotal	\$96,005.00

Pre-Tax Adjustments

Code	Description	
01 ft	DISCOUNT AND CONCESSION	-\$17,046.00
Total		\$78,959.00

Customer Signature

Acceptance Date

Prices and content availability as shown are subject to change and should be treated as estimates only. Actual base vehicle, package and option pricing may vary from this estimate because of special local pricing, availability or pricing adjustments not reflected in the dealer's computer system. See salesperson for the most current information.

Note: Prices and content availability as shown are subject to change and should be treated as estimates only. Actual base vehicle, package and option pricing may vary from this estimate because of special local pricing, availability or pricing adjustments not reflected in the dealer's computer system. See salesperson for the most current information.



Prepared by: Ed Miller
09/18/2020

Chastang Ford | 6200 N. Loop East Houston Texas | 770261936

2021 F-750 Diesel Regular Cab Base (F7D)

Price Level: 120 | Quote ID: GALSD21F7D

Vehicle Dimension and Performance Summary

Performance predictions in this report represent an estimate of vehicle performance based on standard operating conditions. Variations in customer equipment, load configuration, ambient conditions, and/or operator driving techniques can cause significant variations in vehicle performance. These values are not representative of results that may be shown in actual dynamometer tests. This report should therefore be used as a guide for comparative vehicle performance.

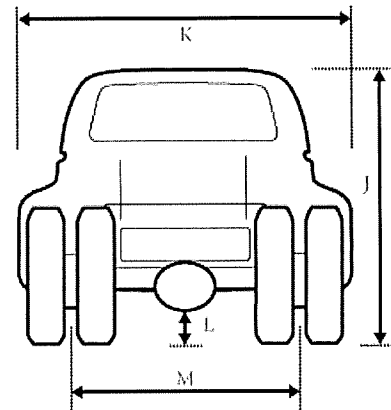
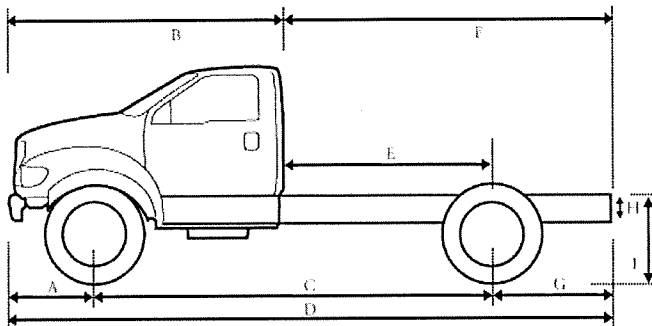

Dimensions

A	Front of Bumper to Front Axle	39.00 in.
B	Front Bumper to Back of Cab (BBC)	113.00 in.
C	Wheelbase (WB)	260.00 in.
D	Overall Length (OAL)	419.00 in.
E	Back of Cab to Rear Axle (CA)	186.00 in.
F	Back of Cab to End of Frame	306.00 in.
G	Rear Axle to End of Frame (AF)	120.00 in.
H	Frame Section Height	10.30 in.
I	Rear Frame Height Unloaded	38.20 in.
I	Rear Frame Height Loaded	36.80 in.
J	Cab Height	94.30 in.
K	Body Width	96.70 in.
L	Maximum Ground Clearance	N/A
L	Minimum Ground Clearance	N/A
M	Front Tread	83.80 in.
M	Rear Tread	72.60 in.

Prices and content availability as shown are subject to change and should be treated as estimates only. Actual base vehicle, package and option pricing may vary from this estimate because of special local pricing, availability or pricing adjustments not reflected in the dealer's computer system. See salesperson for the most current information.

Note: Prices and content availability as shown are subject to change and should be treated as estimates only. Actual base vehicle, package and option pricing may vary from this estimate because of special local pricing, availability or pricing adjustments not reflected in the dealer's computer system. See salesperson for the most current information.



Prepared by: Ed Miller
09/18/2020

Chastang Ford | 6200 N. Loop East Houston Texas | 770261936

2021 F-750 Diesel Regular Cab Base (F7D)

Price Level: 120 | Quote ID: GALSD21F7D

Vehicle Dimension and Performance Summary (cont'd)

Body Specs

Truck body style:	Van
Cab to body gap:	3.00 in.
Body length:	24.00 ft
Body tare weight:	3,600 lbs
Body width:	102 in.
Body height from ground:	150 in.
Body Centre gravity (from front):	144.00 in.

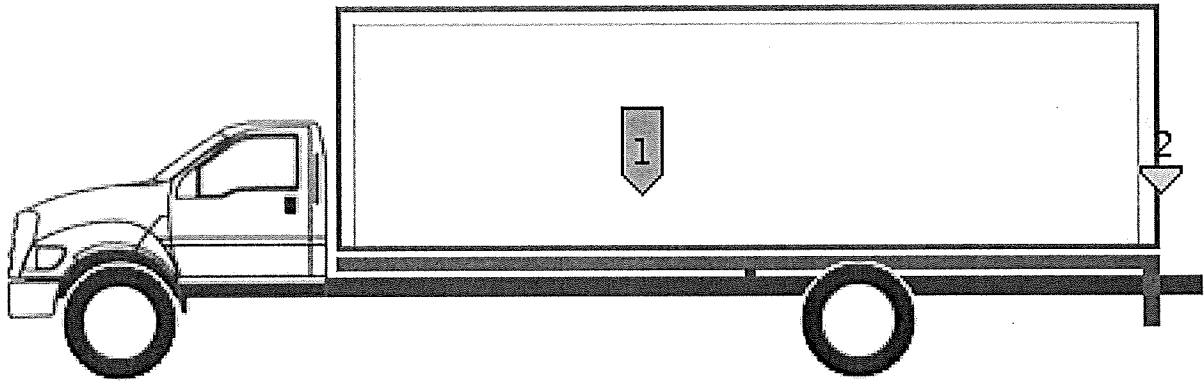

Prices and content availability as shown are subject to change and should be treated as estimates only. Actual base vehicle, package and option pricing may vary from this estimate because of special local pricing, availability or pricing adjustments not reflected in the dealer's computer system. See salesperson for the most current information.

Note: Prices and content availability as shown are subject to change and should be treated as estimates only. Actual base vehicle, package and option pricing may vary from this estimate because of special local pricing, availability or pricing adjustments not reflected in the dealer's computer system. See salesperson for the most current information.



Prepared by: Ed Miller
09/18/2020

Chastang Ford | 6200 N. Loop East Houston Texas | 770261936

2021 F-750 Diesel Regular Cab Base (F7D)

Price Level: 120 | Quote ID: GALSD21F7D

Vehicle Dimension and Performance Summary (cont'd)

Body Specs

Truck body style:	Van
Cab to body gap:	3.00 in.
Body length:	24.00 ft
Body tare weight:	3,600 lbs
Body width:	102 in.
Body height from ground:	150 in.
Body Centre gravity (from front):	144.00 in.

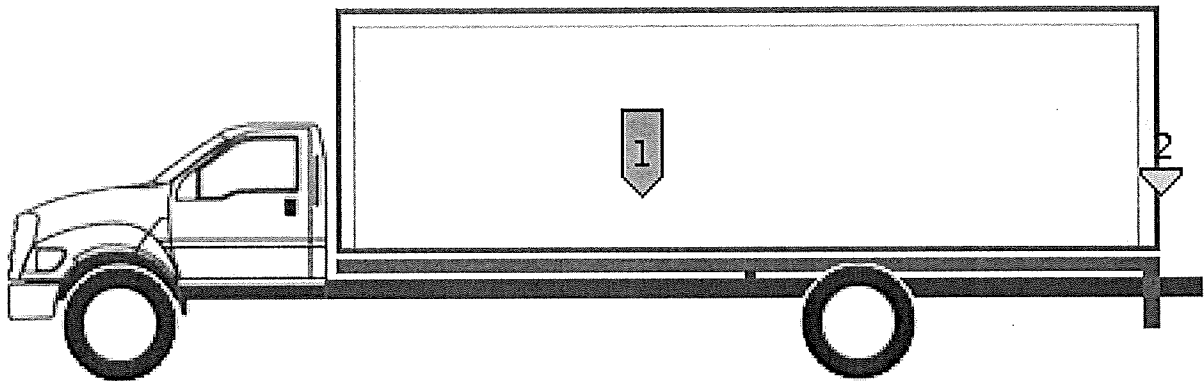

Prices and content availability as shown are subject to change and should be treated as estimates only. Actual base vehicle, package and option pricing may vary from this estimate because of special local pricing, availability or pricing adjustments not reflected in the dealer's computer system. See salesperson for the most current information.

Note: Prices and content availability as shown are subject to change and should be treated as estimates only. Actual base vehicle, package and option pricing may vary from this estimate because of special local pricing, availability or pricing adjustments not reflected in the dealer's computer system. See salesperson for the most current information.



Prepared by: Ed Miller
09/18/2020

Chastang Ford | 6200 N. Loop East Houston Texas | 770261936

2021 F-750 Diesel Regular Cab Base (F7D)

Price Level: 120 | Quote ID: GALSD21F7D

Vehicle Dimension and Performance Summary (cont'd)

Weight

GVW	Front Axle	Rear Axle	Totals
Chassis	6,325 lbs	3,792 lbs	10,117 lbs
Body	540 lbs	3,060 lbs	3,600 lbs
Occupants Weight	200 lbs	100 lbs	300 lbs
1 Max Payload - (Max Payload)	3,257 lbs	7,925 lbs	11,182 lbs
2 Point Load - (Point Load)	-322 lbs	1,122 lbs	800 lbs
TOTAL	10,000 lbs	15,999 lbs	25,999 lbs

Ratings	Front Axle	Rear Axle	GVWR
GAWR	10,000 lbs	21,000 lbs	25,999 lbs
Wheels/Tires	12,350 lbs	23,360 lbs	
Suspension	10,000 lbs	23,000 lbs	
Axle	10,000 lbs	21,000 lbs	
Legal Axle Limit	0 lbs	0 lbs	

Front And Rear GAWR Total Will Exceed Overall GVWR

Prices and content availability as shown are subject to change and should be treated as estimates only. Actual base vehicle, package and option pricing may vary from this estimate because of special local pricing, availability or pricing adjustments not reflected in the dealer's computer system. See salesperson for the most current information.

Note: Prices and content availability as shown are subject to change and should be treated as estimates only. Actual base vehicle, package and option pricing may vary from this estimate because of special local pricing, availability or pricing adjustments not reflected in the dealer's computer system. See salesperson for the most current information.



Prepared by: Ed Miller
09/18/2020

Chastang Ford | 6200 N. Loop East Houston Texas | 770261936

2021 F-750 Diesel Regular Cab Base (F7D)

Price Level: 120 | Quote ID: GALSD21F7D

Vehicle Dimension and Performance Summary (cont'd)

Start, Grade and Speed

Shift Indicator

Vehicle equipped without Park Pawl. Shift indicator will display RNDM.

Start	Ratio	Desired	Calculated
Start grade capability in 1st gear	3.97	15.00 %	28.36 %
Start grade capability in reverse	3.13	15.00 %	22.33 %
Grade	Ratio	Desired	Calculated
Maximum grade in 4th gear	1.15	3.00 %	8.87 %
Maximum grade in 5th gear	0.86	3.00 %	6.62 %
Maximum grade in 6th gear	0.67	3.00 %	5.20 %
Speed		Desired	Calculated
Top Speed (level grade)		75 mph	93 mph
<i>To meet your requirement you need a maximum axle ratio of 7.64</i>			
Top Speed on 3.0% grade		55 mph	
<i>To meet your requirement you need a maximum of 166 hp</i>			
Cruise Speed		60 mph	67 mph
Engine RPM at desired cruise speed			2,067 rpm

Variables in Use

Rear axle ratio:	6.17/6.17	Governed RPM:	3,200 rpm
Tire size:	11R22.5 (497 rev/mile)	Frontal Area:	57.28 Sq.Ft.
Gross Vehicle Weight (GVW):	25,999 lbs	Cruising RPM	2,300 rpm
Clutch engagement torque:	350 ft.lbs.	Worst road surface	Typical Highway
Torque conversion ratio:	1.85	Final Drive Ratio:	0.67
Peak engine torque:	700 ft.lbs.	Drag Coefficient	0.80
Engine Power:	270 hp @ 2,400 rpm		

Prices and content availability as shown are subject to change and should be treated as estimates only. Actual base vehicle, package and option pricing may vary from this estimate because of special local pricing, availability or pricing adjustments not reflected in the dealer's computer system. See salesperson for the most current information.

Note: Prices and content availability as shown are subject to change and should be treated as estimates only. Actual base vehicle, package and option pricing may vary from this estimate because of special local pricing, availability or pricing adjustments not reflected in the dealer's computer system. See salesperson for the most current information.



Prepared by: Ed Miller
09/18/2020

Chastang Ford | 6200 N. Loop East Houston Texas | 770261936

2021 F-750 Diesel Regular Cab Base (F7D)

Price Level: 120 | Quote ID: GALSD21F7D

Vehicle Dimension and Performance Summary (cont'd)

Shift Chart

Shift Chart displays mathematical geared speed.

Diesel engines use Governed RPM for shift points.

Gas engines use Peak Torque RPM for shift points.

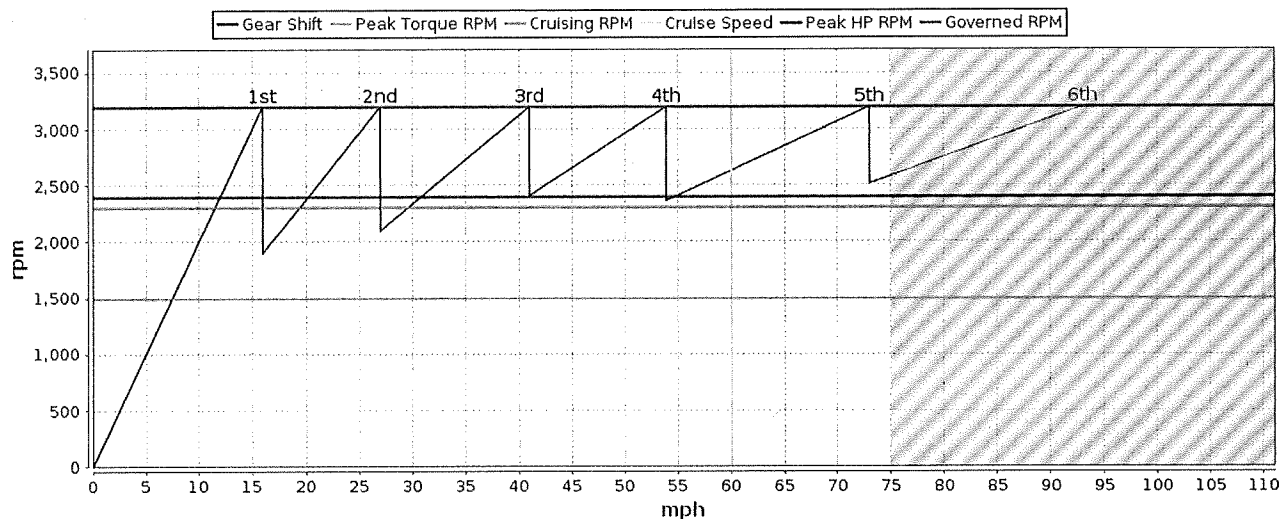

Turning Radius

Turning radius to curb: 33.79 ft
 Turning radius to bumper: 35.50 ft

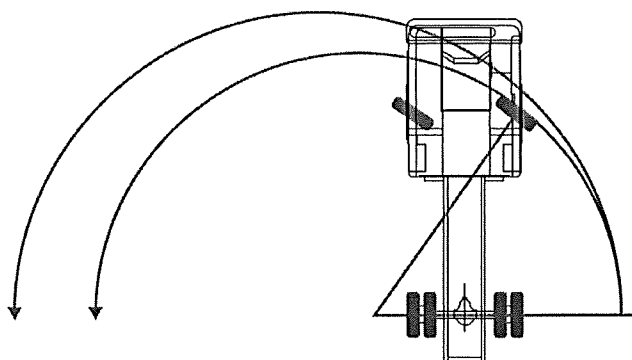

Prices and content availability as shown are subject to change and should be treated as estimates only. Actual base vehicle, package and option pricing may vary from this estimate because of special local pricing, availability or pricing adjustments not reflected in the dealer's computer system. See salesperson for the most current information.

Note: Prices and content availability as shown are subject to change and should be treated as estimates only. Actual base vehicle, package and option pricing may vary from this estimate because of special local pricing, availability or pricing adjustments not reflected in the dealer's computer system. See salesperson for the most current information.



Prepared by: Ed Miller
09/18/2020

Chastang Ford | 6200 N. Loop East Houston Texas | 770261936

2021 F-750 Diesel Regular Cab Base (F7D)

Price Level: 120 | Quote ID: GALSD21F7D

Selected Equip & Specs

Dimensions

- * **Exterior length: 419.0"**
- Exterior width: 96.7"
- * **Wheelbase: 260.0"**
- Rear track: 72.6"
- Front legroom: 41.4"
- Front hiproom: 67.6"
- * **Cab to axle: 186.0"**
- Exterior height: 94.3"
- Front track: 83.8"
- Rear tire outside width: 96.0"
- Front headroom: 40.7"
- Front shoulder room: 68.0"

Powertrain

- 270hp 6.7L OHV 32 valve intercooled turbo V-8 engine with diesel direct injection
- federal
- Rear-wheel drive
- Fuel Economy Highway: N/A
- Fuel/water separator
- Standard rear differential
- Right mounted horizontal tailpipe
- Recommended fuel : diesel
- 6 speed automatic transmission with overdrive
- Fuel Economy Cty: N/A
- 50.0 gal. rectangular Left front fuel tank
- * **Transmission PTO provision**
- Right mounted horizontal muffler

Suspension/Handling

- Front non-independent leaf spring suspension
- Hydraulic power-assist re-circulating ball Steering
- 11.0R22.5 AS front and rear tires
- Rubber auxiliary rear springs
- Rear rigid axle leaf spring suspension
- Front and rear 22.5 x 8.25 wheels
- Dual rear wheels

Body Exterior

- 2 doors
- Black door mirrors
- Side steps
- Straight front bumper ends
- Front and rear 22.5 x 8.25 white steel wheels with 10 wheel studs
- * **Driver and passenger heated, manual folding door mirrors**
- Black bumpers
- Clearcoat paint
- Hood mounted grille
- 2 front tow hook(s)

Convenience

- Manual air conditioning
- * **Power front windows**
- * **Power door locks**
- Manual telescopic steering wheel
- Cruise control with steering wheel controls
- * **Driver and passenger 1-touch down**
- Manual tilt steering wheel
- Wireless phone connectivity

Prices and content availability as shown are subject to change and should be treated as estimates only. Actual base vehicle, package and option pricing may vary from this estimate because of special local pricing, availability or pricing adjustments not reflected in the dealer's computer system. See salesperson for the most current information.

Note: Prices and content availability as shown are subject to change and should be treated as estimates only. Actual base vehicle, package and option pricing may vary from this estimate because of special local pricing, availability or pricing adjustments not reflected in the dealer's computer system. See salesperson for the most current information.



Prepared by: Ed Miller
09/18/2020

Chastang Ford | 6200 N. Loop East Houston Texas | 770261936

2021 F-750 Diesel Regular Cab Base (F7D)

Price Level: 120 | Quote ID: GALSD21F7D

Selected Equip & Specs (cont'd)

- Front cupholders
- Dual electric horn
- * **Driver and passenger door bins**
- Passenger visor mirror
- Automatic gearshift steering column lever
- Upfitter switches

Seats and Trim

- * **Seating capacity of 3**
- Fixed passenger seat
- * **Bucket driver seat, two person bench passenger seat**
- * **High back seats**
- Driver seat with 4 way direction control, passenger seat with 2 way direction control
- * **Fixed headrests**
- Fixed driver seat
- * **Driver centre front armrest**
- * **Driver seat folding back,**
- * **Driver seat air suspension,**
- Manual fore/aft seats

Entertainment Features

- AM/FM stereo radio
- Steering wheel mounted radio controls
- Streaming audio
- Auxiliary audio input
- 2 speakers
- Fixed antenna

Lighting, Visibility and Instrumentation

- Halogen aero-composite headlights
- Variable intermittent front windshield wipers
- Front reading lights
- * **Voltmeter**
- Trip computer
- RNDM
- Fully automatic headlights
- Light tinted windows
- Tachometer
- Oil pressure gauge
- Trip odometer

Safety and Security

- 4-wheel ABS brakes
- Hydraulic disc brakes
- * **Power door locks**
- Hill hold control
- ABS traction control
- With stolen vehicle tracking system

Dimensions

General Weights

* Curb	10,117 lbs.	Front GAWR	10000 lbs.
Rear GAWR	21000 lbs.	GVWR	25999 lbs.
GCWR	50000 lbs.		

Prices and content availability as shown are subject to change and should be treated as estimates only. Actual base vehicle, package and option pricing may vary from this estimate because of special local pricing, availability or pricing adjustments not reflected in the dealer's computer system. See salesperson for the most current information.

Note: Prices and content availability as shown are subject to change and should be treated as estimates only. Actual base vehicle, package and option pricing may vary from this estimate because of special local pricing, availability or pricing adjustments not reflected in the dealer's computer system. See salesperson for the most current information.



Prepared by: Ed Miller
09/18/2020

Chastang Ford | 6200 N. Loop East Houston Texas | 770261936

2021 F-750 Diesel Regular Cab Base (F7D)

Price Level: 120 | Quote ID: GALSD21F7D

Selected Equip & Specs (cont'd)

Front Weights

* Front curb weight	6,325 lbs.	Front axle capacity	10,000 lbs.
Front spring rating	10,000 lbs.	Front tire/wheel capacity	12,350 lbs.

Rear Weights

* Rear curb weight	3,792 lbs.	Rear axle capacity	21,000 lbs.
* Rear spring rating	23,000 lbs.	Rear tire/wheel capacity	23,360 lbs.

Fuel Tank type

Left front Fuel tank capacity	50.01 gal.
-------------------------------	------------

Front Frame

Height loaded	35 "	Height unloaded	37 "
---------------	------	-----------------	------

Rear Frame

* Height loaded	37 "	Height unloaded	38 "
-----------------	-------------	-----------------	------

Front And Rear GAWR Total Will Exceed Overall GVWR

Powertrain

Engine Type

Block material	Iron	Cylinders	V-8
Head material	Aluminum	Ignition	Compression
Injection	Diesel direct injection	Liters	6.7L
Orientation	Longitudinal	Recommended fuel	Diesel
Valves per cylinder	4	Valvetrain	OHV
Forced induction	Intercooled turbo		

Engine Spec

Bore	3.90"	Compression ratio	16.2:1
Displacement	406 cu.in.	Stroke	4.25"

Engine Power

Output	270 HP @ 2,400 RPM	Torque	700 ft.-lb @ 1,500 RPM
Governed RPM	3,200		

Alternator

Type	HD	Amps	200
------	----	------	-----

Battery

Cold cranking amps	1,500	Location	Forward right
Step	Yes	Type	Dual

Prices and content availability as shown are subject to change and should be treated as estimates only. Actual base vehicle, package and option pricing may vary from this estimate because of special local pricing, availability or pricing adjustments not reflected in the dealer's computer system. See salesperson for the most current information.

Note: Prices and content availability as shown are subject to change and should be treated as estimates only. Actual base vehicle, package and option pricing may vary from this estimate because of special local pricing, availability or pricing adjustments not reflected in the dealer's computer system. See salesperson for the most current information.



Prepared by: Ed Miller
09/18/2020

Chastang Ford | 6200 N. Loop East Houston Texas | 770261936

2021 F-750 Diesel Regular Cab Base (F7D)

Price Level: 120 | Quote ID: GALSD21F7D

Selected Equip & Specs (cont'd)

Engine Extras

* Block heater Yes

Transmission

Electronic control	Yes	Lock-up	Yes
Overdrive	Yes	Speed	6
Type	Automatic		

Transmission Gear Ratios

1st	3.974	2nd	2.318
3rd	1.516	4th	1.149
5th	0.858	6th	0.674
Reverse Gear ratios	3.128		

Transmission Torque Converter

Stall ratio 1.85

Transmission Extras

Driver selectable mode	Yes	Sequential shift control	Yes
Oil cooler	Regular duty	* PTO provision	Yes

Drive Type

Type Rear-wheel

Drive Feature

Traction control ABS

Drive Axle

* Ratio 6.17

Exhaust

Material	Aluminized steel	System type	Single
----------	------------------	-------------	--------

Emissions

CARB Federal

Engine Retarder

Type Yes

Driveability

Brakes

ABS	4-wheel	ABS channels	4
Type	Hydraulic disc	Vented discs	Front and rear

Prices and content availability as shown are subject to change and should be treated as estimates only. Actual base vehicle, package and option pricing may vary from this estimate because of special local pricing, availability or pricing adjustments not reflected in the dealer's computer system. See salesperson for the most current information.

Note: Prices and content availability as shown are subject to change and should be treated as estimates only. Actual base vehicle, package and option pricing may vary from this estimate because of special local pricing, availability or pricing adjustments not reflected in the dealer's computer system. See salesperson for the most current information.



Prepared by: Ed Miller
09/18/2020

Chastang Ford | 6200 N. Loop East Houston Texas | 770261936

2021 F-750 Diesel Regular Cab Base (F7D)

Price Level: 120 | Quote ID: GALSD21F7D

Selected Equip & Specs (cont'd)

Brake Assistance

Hill hold control Yes

Suspension Control

Ride Regular

Front Suspension

Independence Non-independent Type Leaf

Front Spring

Type Tapered leaf Grade Regular

Front Shocks

Type Regular

Rear Suspension

Independence Rigid axle Type Leaf

Rear Spring

Type Multi-leaf Grade Regular

Auxiliary Rubber

Steering

Activation Hydraulic power-assist Type Re-circulating ball

Steering Specs

of wheels 2

Exterior

Front Wheels

Diameter 22.5" Width 8.25"

Rear Wheels

Diameter 22.5" Width 8.25"

Dual Yes

Front Tires

Aspect 82 Diameter 22.5"

Sidewalls BSW Tread AS

Width 11.0" LT load rating G

RPM 497

Rear Tires

Aspect 82 Diameter 22.5"

Prices and content availability as shown are subject to change and should be treated as estimates only. Actual base vehicle, package and option pricing may vary from this estimate because of special local pricing, availability or pricing adjustments not reflected in the dealer's computer system. See salesperson for the most current information.

Note: Prices and content availability as shown are subject to change and should be treated as estimates only. Actual base vehicle, package and option pricing may vary from this estimate because of special local pricing, availability or pricing adjustments not reflected in the dealer's computer system. See salesperson for the most current information.



Prepared by: Ed Miller
09/18/2020

Chastang Ford | 6200 N. Loop East Houston Texas | 770261936

2021 F-750 Diesel Regular Cab Base (F7D)

Price Level: 120 | Quote ID: GALSD21F7D

Selected Equip & Specs (cont'd)

Sidewalls	BSW	Tread	AS
Width	11.0"	LT load rating	G
RPM	497		

Wheels

Front track	83.8"	Rear track	72.6"
* Turning radius (to curb)	34'	* Turning radius (to bumper)	35'
* Wheelbase	260.0"	Rear tire outside width	96.0"

Body Features

Front splash guards	Yes	* Rear splash guards	Holders only
Body material	Composite/galvanized steel	Side steps	Yes
Front tow hook(s)	2		

Body Doors

Door count	2
------------	---

Exterior Dimensions

* Length	419.0"	Body width	96.7"
Body height	94.3"	* Cab to axle	186.0"
* Axle to end of frame	120.0"	Frame section modulus	15.1cu.in.
Frame yield strength (psi)	80000.0	Frame rail depth	10.3"
Frame rail width	3.1"	Frame rail thickness	0.4"
Max RBM (in.-lbs.)	1,275,200.0	Frame rail section	9.5"
Front bumper to Front axle	39.0"	Nominal RBM (in.-lbs.)	1,211,200.0

Seating

Passenger Capacity

* Capacity	3
-------------------	----------

Driver Seat

Type	Bucket	Back	Folding
* Back type	High	* Suspension	Air
Way direction control	4	Fore/aft	Manual

Driver Headrest

* Type	Fixed
---------------	--------------

Passenger Seat

* Type	Two person bench	* Back type	High
---------------	-------------------------	--------------------	-------------

Prices and content availability as shown are subject to change and should be treated as estimates only. Actual base vehicle, package and option pricing may vary from this estimate because of special local pricing, availability or pricing adjustments not reflected in the dealer's computer system. See salesperson for the most current information.

Note: Prices and content availability as shown are subject to change and should be treated as estimates only. Actual base vehicle, package and option pricing may vary from this estimate because of special local pricing, availability or pricing adjustments not reflected in the dealer's computer system. See salesperson for the most current information.



Prepared by: Ed Miller
09/18/2020

Chastang Ford | 6200 N. Loop East Houston Texas | 770261936

2021 F-750 Diesel Regular Cab Base (F7D)

Price Level: 120 | Quote ID: GALSD21F7D

Selected Equip & Specs (cont'd)

Way direction control 2 Fore/aft Manual

Passenger Headrest

* Type Fixed

Front Armrest

Driver Yes * Centre Yes

Front Seat Trim

Material Vinyl Back material Carpet

Convenience

AC And Heat Type

Air conditioning Manual

Audio System

Auxiliary audio input Yes Radio AM/FM stereo
Radio grade Regular Seek-scan Yes

Audio Speakers

Speaker type Regular Speakers 2

Audio Controls

Steering wheel controls Yes Streaming audio Bluetooth yes

Audio Antenna

Type Fixed

Cruise Control

Cruise control With steering wheel controls

Convenience Features

12V DC power outlet 2 Wireless phone connectivity Bluetooth
Horn Dual electric Upfitter switches Yes

Door Lock Activation

* Type Power

Instrumentation Type

Display Analog

Instrumentation Gauges

Tachometer Yes Oil pressure Yes
Engine temperature Yes * Voltmeter Yes

Prices and content availability as shown are subject to change and should be treated as estimates only. Actual base vehicle, package and option pricing may vary from this estimate because of special local pricing, availability or pricing adjustments not reflected in the dealer's computer system. See salesperson for the most current information.

Note: Prices and content availability as shown are subject to change and should be treated as estimates only. Actual base vehicle, package and option pricing may vary from this estimate because of special local pricing, availability or pricing adjustments not reflected in the dealer's computer system. See salesperson for the most current information.



Prepared by: Ed Miller
09/18/2020

Chastang Ford | 6200 N. Loop East Houston Texas | 770261936

2021 F-750 Diesel Regular Cab Base (F7D)

Price Level: 120 | Quote ID: GALSD21F7D

Selected Equip & Specs (cont'd)

Transmission fluid temp	Yes	Engine hour meter	Yes
<i>Instrumentation Warnings</i>			
Battery	Yes	Lights on	Yes
Key	Yes	Service interval	Yes
Brake fluid	Yes	Transmission fluid temp	Yes
<i>Instrumentation Displays</i>			
Clock	In-radio display		
<i>Instrumentation Feature</i>			
Trip computer	Yes	Trip odometer	Yes
Shift indicator	RNDM		
<i>Steering Wheel Type</i>			
Material	Urethane	Tilting	Manual
Telescoping	Manual		
<i>Front Side Windows</i>			
* Window 1st row activation	Power		
<i>Window Features</i>			
* 1-touch down	Driver and passenger	Tinted	Light
<i>Front Windshield</i>			
Wiper	Variable intermittent		
<i>Rear Windshield</i>			
Window	Fixed		
<i>Automatic Gearshift</i>			
Location	Steering column lever		

Interior

<i>Passenger Visor</i>			
Mirror	Yes		
<i>Headliner</i>			
Coverage	Full	Material	Cloth
<i>Floor Trim</i>			
Coverage	Full	Covering	Vinyl/rubber
<i>Trim Feature</i>			

Prices and content availability as shown are subject to change and should be treated as estimates only. Actual base vehicle, package and option pricing may vary from this estimate because of special local pricing, availability or pricing adjustments not reflected in the dealer's computer system. See salesperson for the most current information.

Note: Prices and content availability as shown are subject to change and should be treated as estimates only. Actual base vehicle, package and option pricing may vary from this estimate because of special local pricing, availability or pricing adjustments not reflected in the dealer's computer system. See salesperson for the most current information.



Prepared by: Ed Miller
09/18/2020

Chastang Ford | 6200 N. Loop East Houston Texas | 770261936

2021 F-750 Diesel Regular Cab Base (F7D)

Price Level: 120 | Quote ID: GALSD21F7D

Selected Equip & Specs (cont'd)

Gear shifter material	Urethane		
<i>Lighting</i>			
Dome light type	Delay	Front reading	Yes
Variable IP lighting	Yes		
<i>Storage</i>			
*Driver door bin	Yes	Front Beverage holder(s)	Yes
Glove box	Yes	*Passenger door bin	Yes
Instrument panel	Bin	Dashboard	Yes
<i>Legroom</i>			
Front	41.4"		
<i>Headroom</i>			
Front	40.7"		
<i>Hip Room</i>			
Front	67.6"		
<i>Shoulder Room</i>			
Front	68.0"		

Prices and content availability as shown are subject to change and should be treated as estimates only. Actual base vehicle, package and option pricing may vary from this estimate because of special local pricing, availability or pricing adjustments not reflected in the dealer's computer system. See salesperson for the most current information.

Note: Prices and content availability as shown are subject to change and should be treated as estimates only. Actual base vehicle, package and option pricing may vary from this estimate because of special local pricing, availability or pricing adjustments not reflected in the dealer's computer system. See salesperson for the most current information.



Prepared by: Ed Miller
09/18/2020

Chastang Ford | 6200 N. Loop East Houston Texas | 770261936

2021 F-750 Diesel Regular Cab Base (F7D)

Price Level: 120 | Quote ID: GALSD21F7D

Warranty

Standard Warranty

Basic

Distance	Unlimited miles	Months	24 months
----------	-----------------	--------	-----------

Powertrain

Distance	Unlimited miles	Months	24 months
----------	-----------------	--------	-----------

Corrosion Perforation

Distance	Unlimited miles	Months	36 months
----------	-----------------	--------	-----------

Roadside Assistance

Distance	Unlimited miles	Months	24 months
----------	-----------------	--------	-----------

Diesel Engine

Distance	250,000 miles	Months	60 months
----------	---------------	--------	-----------

Transmission

Distance	250,000 miles	Months	60 months
----------	---------------	--------	-----------

Frame Rail

Distance	Unlimited miles	Months	60 months
----------	-----------------	--------	-----------

Prices and content availability as shown are subject to change and should be treated as estimates only. Actual base vehicle, package and option pricing may vary from this estimate because of special local pricing, availability or pricing adjustments not reflected in the dealer's computer system. See salesperson for the most current information.

Note: Prices and content availability as shown are subject to change and should be treated as estimates only. Actual base vehicle, package and option pricing may vary from this estimate because of special local pricing, availability or pricing adjustments not reflected in the dealer's computer system. See salesperson for the most current information.

November 5, 2020

Sent via email to: emiller@chastangford.com

Ed Miller
Chastang Enterprises, Inc.
6200 North Loop East
Houston TX 77026

Re: Vehicles, Heavy Duty Trucks, Police Motorcycles, Parts, and Service Labor
BuyBoard Contract 601-19

The Local Government Purchasing Cooperative (BuyBoard) awarded your company a contract under Vehicles, Heavy Duty Trucks, Police Motorcycles, Parts, and Service Labor, Contract 601-19 effective December 1, 2019 through November 30, 2020 with two possible one-year renewals. At this time, the BuyBoard is renewing your contract through November 30, 2021.

All discounts, terms, and conditions of your contract will remain the same. If you agree to this renewal, there is nothing you need to do. However, if you do not agree to this renewal, you must notify me via email at lisa.maraden@tasb.org prior to the start of the renewal term.

Reminder: Once a BuyBoard contract is awarded, vendors must generate a minimum of \$15,000 annually or they may not be offered a contract renewal.

If you have questions or comments concerning this renewal, please contact me as soon as possible at lisa.maraden@tasb.org. We appreciate your interest in The Local Government Purchasing Cooperative.

Sincerely,

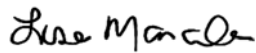

Lisa Maraden
Contract Administrator

1st renewal v.02.13.2020

DEALER 52E 909

VIN 1FDWF7DE4KDF12522

	Suggested Retail Price	Invoice Price
F75E REGULAR CAB DOCK HGT	69455 00	60553 00
260" WHEELBASE	965 00	852 00
2019 MODEL YEAR		
YZ OXFORD WHITE		
GE STEEL GRAY VINYL 30/70		
PREFERRED EQUIPMENT PKG.600A		
.SINGLE, 21K CAP OPEN		
.ENGINE EXHAUST BRAKE		
.FUEL TANK - 50 GALS ALUMINUM		
.REAR SEAT DELETE		
.ARGENT GRILLE		
.AIR CONDITIONING		
.AUXILIARY SWITCH (4)		
.PT WH 22.5X8.25 10H PWD CT DS		
.RR WH 22.5X8.25 10H PT STL DS		
99E 6.7L POWER STROKE DSL 300 HP	1995 00	1761 00
.6 SPEED AUTO TRANS DSL		
TCG GDYR 11R22.5G ENDURAM RSA	NC	NC
X6D 6.50 AXLE RATIO	NC	NC
15V VOLTMETER	100 00	88 00
163 RP MARKER/CLRNC LIGHTS AMBER	NC	NC
17M BACKUP ALARM, ELECTRIC	110 00	97 00
18D DE-RATE GVWR TO 25,999	120 00	106 00
18P DRIVESHAFT UPGRADE	185 00	164 00
21D SYNC MEDIA SYSTEM	395 00	349 00
41A TRANS POWER TAKE OFF DIESEL	895 00	790 00
41H ENGINE BLOCK HEATER	60 00	53 00
425 50 STATE EMISSIONS	NC	NC
43P FRONT AXLE - 12K CAPACITY	525 00	464 00
538 FRAME RAILS 10.25 120 PSI	650 00	574 00
54R XL2020 PWR/HTD BLACK 102"	275 00	242 00
55M JUMP START STUD	90 00	80 00
586 PREM ELEC AM/FM/CD/MP3	290 00	247 00
59A AIR HORN	90 00	80 00
59C BODY BUILDER WIRING	135 00	119 00
60A SYNTHETIC FRT WHL BEARING LUBE	50 00	45 00
607 SYN LUBE, REAR AXLE	100 00	88 00
61D FRONT SUSPENSION - 12K CAP	305 00	269 00
62B AIR COMPRESSOR - BENDIX 13.2CF	NC	NC
62D AIR DRYER	460 00	406 00
63B BATTERY - 2 - 12V 1800 CCA	60 00	53 00
67C AIR BRAKES	1770 00	1562 00
G 30/70 AIR RIDE DRIVER VINYL	395 00	349 00
90P POWER EQUIPMENT GROUP	470 00	415 00
961 REAR SHOCK ABSORBERS	165 00	146 00
962 DAYTIME RUNNING LIGHTS	45 00	39 00
DISCOUNTED EQUIPMENT		
GDYR 11R22.5G G182	120 00	106 00
TOTAL OPTIONS/OTHER	10810 00	9544 00
TOTAL VEHICLE & OPTIONS/OTHER	80265 00	70097 00
DESTINATION & DELIVERY	2095 00	2095 00
TOTAL FOR VEHICLE	82360 00	
FUEL CHARGE		37 08

197115

This invoice may not reflect the final cost of the vehicle in view of the possibility of future rebates, allowances, discounts and incentive awards from Ford Motor Company to the dealer.

Sold to					
		Order Type	Ramp Code	Batch ID	Price Level
Ship to (if other than above)		Date Inv. Prepared		Item Number	Transit Days
		Ship Through			
Invoice & Unit Identification NO.		Final Assembly Point		Finance Company and/or Bank	
HB	Invoice Total	A & Z Plan	D Plan	X Plan	FPA
			147		AA

This invoice to be used for the billing of vehicles only

Dealer's copy

DEALER 52E 909

VIN 1FDWF7DE4KDF12522

SHIPPING WEIGHT: 11819 LBS	Suggested Retail Price	Invoice Amount
TOTAL	82360.00	72229.08

197115
STK

This invoice may not reflect the final cost of the vehicle in view of the possibility of future rebates, allowances, discounts and incentive awards from Ford Motor Company to the dealer.

Sold to Grande Truck Center P.O. BOX 201210 San Antonio TX 78220		52E909 TX 78220		Order Type 1	Ramp Code CR07	Batch ID KG301	Price Level 950
Ship to (if other than above) Grande Truck Center 4562 IH 10 East San Antonio TX		52909		Date Inv. Prepared 07 30 19	Item Number 52-7115	Transit Days 01	Ship Through
Invoice & Unit Identification NO. 1FDWF7DE4KDF12522		Final Assembly Point OHIO		Finance Company and/or Bank Ford Motor Credit 000001			
HB	Invoice Total	A & Z Plan	D Plan	X Plan	FPA	AA	
2411	72229.08		148		995.00		

This invoice to be used for the billing of vehicles only

Dealer's copy

Invoice

Number 042412



GRANDE TRUCK CENTER
4562 IH 10 EAST
SAN ANTONIO, TX 78219
USA

Smyrna Truck & Cargo
2158 Atlanta Road
Smyrna, Georgia 30080

Telephone: 770-433-0112
Fax: 770-438-1504

Invoice Date 11/15/2019
Due Date 12/15/2019 NET30
Sales order SO-045276
VIN: 1FDWF7DE6KDF12523
Requisition PO# 23562
Your reference
Our reference Marshall Hale
Payment NET 30 DAYS
Invoice account 71468

Item number	Description	Quantity	Unit	Unit price	Discount	Amount
000186_202	BODY, DRY FREIGHT Quantity: 1.00 Serial number: SO-045276	1.00	ea	14,655.00	0	\$14655.00
BODY	Aluminum Sheet and Post Dry Freight Van Body 24' Length - 102" Height - 102" Width .040" Pre-painted Aluminum Sides Extruded Aluminum Corner Post Galvannealed Steel Rear Frame with Integral Rain Gutter Aluminum Tread-Brite Front Radius Cast Aluminum Corner Caps Galvanized Anti-Snag Roof Bows on 24" Centers FMVSS 108 Exterior LED Lights & Reflectors Asphaltic Undercoat -FURNISH & INSTALL A 2500LB. TUCKUNDER LIFTGATE WITH 48X80 STEEL PLATFORM	1.00				
ROOFING	Aluminum 24" x 102"	1.00				
DOOR	102X102 BODY PREMIUM PLASTIC 94 INCH WIDE X 96.875 INCH HIGH 2132 DOOR	1.00				
FLOORING	1.125" Laminated Hardwood Floor 24' Length 102" Width	1.00				
POST	Front Wall 1.375 Galvanized Steel Z-Post	1.00				
SIDE WALL POSTS	1.375" Galvanized Steel 16" Centers for 24'L x 102"H Body	1.00				
LIGHT KIT	RECESSED LIGHT KIT	1.00				
LINING	E-Track 2 Rows 24' Length -MOUNT AT 30" & 48" C/L	1.00				

Invoice

Number: 042412



POST	2 LIGHT 12GA X 11.1875 X 106.25 CURBSIDE GALVANNEALED CORNER POST	1.00
POST	2 LIGHT 12GA X 11.1875 X 106.25 ROADSIDE GALVANNEALED CORNER POST	1.00
SIDE LIN. PLY UNI 3/	SIDE LIN. PLY UNI 3/8X102X20	1.00
FRONT LINING	PLYWOOD 1/2 INCH 102" Height 102" Width	1.00
SUB FRAME	Forklift Package 102" Width	1.00
THRESHOLD	WIDE 1 INCH GALVANIZED THRESHOLD	1.00
LIGHT KIT	RECESSED LIGHT KIT	1.00
BACK UP ALARM	STANDARD BACK UP ALARM	1.00
LIGHT	DOME LIGHT W/ REAR MOUNT SWITCH	2.00
GRAB HANDLE	CURBSIDECHROME GRAB HANDLE	1.00
GRAB HANDLE	ROADSIDECHROME GRAB HANDLE	1.00
MUD FLAP	24 INCH X 36 INCH SMYRNA CARGO MUD FLAP -WEIGHT TICKET & CERTIFICATION -DELIVERY TO GRANDE FORD	1.00

Sales subtotal amount	Total discount	Total charges	Net amount	Sales tax	Round-off	Total
14,655.00	0.00	250.00	14,905.00	0.00	0.00	14,905.00 USD

Invoice

Number 042411



GRANDE TRUCK CENTER
4562 IH 10 EAST
SAN ANTONIO, TX 78219
USA

Smyrna Truck & Cargo
2158 Atlanta Road
Smyrna, Georgia 30080

Telephone: 770-433-0112
Fax: 770-438-1504

Invoice Date 11/15/2019
Due Date 12/15/2019 NET30
Sales order SO-045275
VIN: 1FDWF7DE4KDF12522
Requisition PO# 23561
Your reference
Our reference Marshall Hale
Payment NET 30 DAYS
Invoice account 71468

197115
13210

Item number	Description	Quantity	Unit	Unit price	Discount	Amount
000186_202	BODY, DRY FREIGHT Quantity: 1.00 Serial number: SO-045275.	1.00	ea	14,655.00	0	\$14655.00
BODY	Aluminum Sheet and Post Dry Freight Van Body 24' Length - 102" Height - 102" Width .040" Pre-painted Aluminum Sides Extruded Aluminum Corner Post Galvannealed Steel Rear Frame with Integral Rain Gutter Aluminum Tread-Brite Front Radius Cast Aluminum Corner Caps Galvanized Anti-Snag Roof Bows on 24" Centers FMVSS 108 Exterior LED Lights & Reflectors Asphaltic Undercoat -FURNISH & INSTALL A 2500LB. TUCKUNDER LIFTGATE WITH 48X80 STEEL PLATFORM	1.00				
ROOFING	Aluminum 24" x 102"	1.00				
DOOR	102X102 BODY PREMIUM PLASTIC 94 INCH WIDE X 96.875 INCH HIGH 2132 DOOR	1.00				
FLOORING	1.125" Laminated Hardwood Floor 24' Length 102" Width	1.00				
POST	Front Wall 1.375 Galvanized Steel Z-Post	1.00				
SIDE WALL POSTS	1.375" Galvanized Steel 16" Centers for 24' L x 102" H Body	1.00				
LIGHT KIT	RECESSED LIGHT KIT	1.00				
LINING	E-Track 2 Rows 24' Length -MOUNT AT 30" & 48" C/L	1.00				

Invoice

Number 042411



POST	2 LIGHT 12GA X 11.1875 X 106.25 CURBSIDE GALVANNEALED CORNER POST	1.00
POST	2 LIGHT 12GA X 11.1875 X 106.25 ROADSIDE GALVANNEALED CORNER POST	1.00
SIDE LIN. PLY UNI 3/	SIDE LIN. PLY UNI 3/8X102X20	1.00
FRONT LINING	PLYWOOD 1/2 INCH 102" Height 102" Width	1.00
SUB FRAME	Forklift Package 102" Width	1.00
THRESHOLD	WIDE 1 INCH GALVANIZED THRESHOLD	1.00
LIGHT KIT	RECESSED LIGHT KIT	1.00
BACK UP ALARM	STANDARD BACK UP ALARM	1.00
LIGHT	DOMELIGHT W/ REAR MOUNT SWITCH	2.00
GRAB HANDLE	CURBSIDECHROME GRAB HANDLE	1.00
GRAB HANDLE	ROADSIDECHROME GRAB HANDLE	1.00
MUD FLAP	24 INCH X 36 INCH SMYRNA CARGO MUD FLAP -WEIGHT TICKET & CERTIFICATION -DELIVERY TO GRANDE FORD	1.00
LIFTGATE	Maxon TE-25 Tuck-A-Way 2500lbs. Capacity 48" x 78.5" +Wedge Steel Platform Serial Number: 1910526106	1.00

Sales subtotal amount	Total discount	Total charges	Net amount	Sales tax	Round-off	Total
14,655.00	0.00	250.00	14,905.00	0.00	0.00	14,905.00 USD



Rush Truck Center - Dallas Medium Duty

4000 Irving Boulevard
 Dallas, TX 75247
 214-631-2050

rushtruckcenters.com

Retail Sales Order

SALES ORDER		Date 12/07/2020	
Please enter my order for the following: <input checked="" type="checkbox"/> New <input checked="" type="checkbox"/> F.E.T. Applicable <input type="checkbox"/> Used <input type="checkbox"/> F.E.T. Exempt		Galveston ISD	
Make Ford	Series F-750	Customer's Name	Galveston TX 77550
Year 2021	Body Type	Street	City State Zip
Color OXFORD WHITE	Trim	3904 Ave T	(409) 789-6002
Serial # 1FDNF7DC6MDF00238		Federal Tax ID #	Business Phone Fax
Stock # 1149112		Purchaser's Name	
To be delivered on or about		Street	City State Zip
BUY BOARD CONTRACT 601-19/	400.00	Federal Tax ID #	Business Phone Fax
2021 FORD F-750 REGULAR CAB, 6.7L DIESEL,		Aaron Davis	
AUTO TRANS, HYD BRAKES, BACK UP ALARM,		By Salesman	
25,999 GVWR, POWER EQUIPMENT,		Truck Will be Titled in _____ County.	
KEYLESS ENTRY,	80,210.00	LIENHOLDER INFORMATION	
26' DRY VAN BODY, 10' SCUFF, 2 ROWS E-TRACK,		Date of Lien	
MAXON 3,00 LB TUCK UNDER LIFT GATE ALUMINUM,	20,090.00	Lien Holder	
GOVERNMENT DISCOUNTS	(12,297.48)		
Sales Price	88,402.52	Draft Through	
Factory Paid F.E.T.	0.00		
F.E.T. Tire Credit	0.00		
Total Factory Paid F.E.T.	0.00		
Optional Extended Warranties	0.00		
Sub-Total	88,402.52		
Dealer Paid F.E.T. *	0.00	Manufacturer Rebate	
Local Taxes	0.00	Total Used Vehicle Allowance *	0.00
License, Transfer, Title, Registration Fee	0.00	Less Total Balance Owed	0.00
Dealer's Inventory Tax		Total Net Allowance on Used Vehicle(s)	0.00
Documentary Fee		Deposit or Credit Balance	0.00
Total Cash Delivered Price		Cash with Order	0.00
Total Down Payment	0.00	←.....	0.00
Unpaid Cash Balance Due on Delivery		*See Trade-in details on page 4	
A DOCUMENTARY FEE IS NOT AN OFFICIAL FEE. A DOCUMENTARY FEE IS NOT REQUIRED BY LAW, BUT MAY BE CHARGED TO CUSTOMERS FOR HANDLING DOCUMENTS RELATING TO THE SALE. A DOCUMENTARY FEE MAY NOT EXCEED A REASONABLE AMOUNT AGREED TO BY PARTIES. THIS NOTICE IS REQUIRED BY LAW.		Customer, by the execution of this Order, offers to purchase the Product(s) described above upon the Terms and Conditions contained herein. Customer acknowledges that Customer has read the Terms and Conditions of this Order on Page 2 and has received a true copy of this Order and the Terms and Conditions.	
The Dealer's Inventory Tax charge is intended to reimburse the Dealer for ad valorem taxes on its motor vehicle inventory. The charge, which is paid by the Dealer to the county tax assessor-collector, is not a tax imposed on a Customer by the government, and is not required to be charged by the Dealer to the Customer.		Customer's Signature	Date
*SUBJECT TO ADJUSTMENT - FINAL F.E.T. MAY VARY ANY F.E.T. VARIANCE RESPONSIBILITY OF DEALER		OFFER RECEIVED BY:	Date
NOTICE: THE FOLLOWING ARE IMPORTANT PROVISIONS OF THIS ORDER THIS ORDER CANCELS AND SUPERCEDES ANY PRIOR AGREEMENTS AND, AS OF THE DATE HEREOF, COMPRISES THE COMPLETE AND EXCLUSIVE STATEMENT OF THE TERMS OF THE AGREEMENT BETWEEN THE PARTIES. IF ANY REPRESENTATIONS, SPECIFICATIONS OR OTHER AGREEMENTS ARE RELIED UPON BY CUSTOMER, THEY MUST BE IN WRITING AND SPECIFICALLY IDENTIFIED AND REFERENCED IN THIS ORDER; OTHERWISE, THEY WILL NOT BE BINDING ON OR ENFORCEABLE AGAINST DEALER. THERE ARE NO UNWRITTEN ORAL AGREEMENTS BETWEEN THE PARTIES.		SALES REPRESENTATIVE	Date
		OFFER ACCEPTED BY:	Date
		AUTHORIZED REPRESENTATIVE	Date



presented by: *David Patterson*
 Micro Integration *Tel: 713-785-4596*
 10801 Hammerly *Fax: 713-785-2276*
 Suite 246
 Houston, Texas 77043

Spin # 143008053

April 29, 2020

**Galveston ISD
 Erate 2020
 Wireless for Oppe and Parker Elementary Campuses
 Cisco Option**

**Parker Elementary
 Cisco 9115 802.1AX Access Point - 44**

Manf.	Model	Description	List	Edu. Cost	Qty	Ext. Cost
Cisco	C9115AXI-B	Cisco Catalyst 9115AX Series	1,245.00	597.60	44	\$26,294.40
Cisco	NETWORK-PNP-LIC	Network Plug-n-Play Connect for zero-touch device deployment	0.00	0.00	44	\$0.00
Cisco	D-DNAS-EXT-T	Cisco DNA Spaces Extend Option for Cisco DNA 1Yr Term	0.00	0.00	44	\$0.00
Cisco	D-DNAS-EXT-3Y	Cisco DNA Spaces Extend Option for Cisco DNA 3Y	75.00	36.00	44	\$1,584.00
Cisco	DNA-A-3Y-C9115	C9115AX CISCO DNA Advantage 3 Year Term Licenses	0.00	0.00	44	\$0.00
Cisco	AIR-AP-T-RAIL-R	Ceiling Grid Clip for Aironet APs - Recessed Mount (Default)	0.00	0.00	44	\$0.00
Cisco	AIR-AP-BRACKET-1	802.11 AP Low Profile Mounting Bracket (Default)	0.00	0.00	44	\$0.00
Cisco	SW9115AX-CAPWAP-K9	Capwap software for Catalyst 9115AX	0.00	0.00	44	\$0.00
Cisco	AIR-DNA-A	Aironet CISCO DNA Advantage Term Licenses	0.00	0.00	44	\$0.00
Cisco	AIR-DNA-A-3Y	Aironet CISCO DNA Advantage Term Licenses	600.00	288.00	44	\$12,672.00
MI		Installation and Configuration		65.00	44	\$2,860.00

Parker Total \$43,410.40

**Oppe Elementary
 Cisco 9115 802.1AX Access Point - 40**

Manf.	Model	Description	List	Edu. Cost	Qty	Ext. Cost
Cisco	C9115AXI-B	Cisco Catalyst 9115AX Series	1,245.00	597.60	40	\$23,904.00
Cisco	NETWORK-PNP-LIC	Network Plug-n-Play Connect for zero-touch device deployment	0.00	0.00	40	\$0.00
Cisco	D-DNAS-EXT-T	Cisco DNA Spaces Extend Option for Cisco DNA 1Yr Term	0.00	0.00	40	\$0.00
Cisco	D-DNAS-EXT-3Y	Cisco DNA Spaces Extend Option for Cisco DNA 3Y	75.00	36.00	40	\$1,440.00
Cisco	DNA-A-3Y-C9115	C9115AX CISCO DNA Advantage 3 Year Term Licenses	0.00	0.00	40	\$0.00
Cisco	AIR-AP-T-RAIL-R	Ceiling Grid Clip for Aironet APs - Recessed Mount (Default)	0.00	0.00	40	\$0.00

Cisco	AIR-AP-BRACKET-1	802.11 AP Low Profile Mounting Bracket (Default)	0.00	0.00	40	\$0.00
Cisco	SW9115AX-CAPWAP-K9	Capwap software for Catalyst 9115AX	0.00	0.00	40	\$0.00
Cisco	AIR-DNA-A	Aironet CISCO DNA Advantage Term Licenses	0.00	0.00	40	\$0.00
Cisco	AIR-DNA-A-3Y	Aironet CISCO DNA Advantage Term Licenses	600.00	288.00	40	\$11,520.00
MI		Installation and Configuration			40	\$2,600.00

Oppe Total

\$39,464.00

Cisco 9800-L Wireless Lan Controller for up to 250 AP's

Manf.	Model	Description	List	Edu. Cost	Qty	Ext. Cost
Cisco	C9800-L-F-K9	Cisco Catalyst 9800-L Wireless Controller_Fiber Uplink	10,000.00	4800.00	1	\$4,800.00
Cisco	CON-SNT-C9800LFL	SNTC-8X5XNBD Cisco Catalyst 9800-L Wireless Controlle	1,300.00	1040.00	1	\$1,040.00
Cisco	SC9800LK9-1612	C9800L UNIVERSAL (NETWORK ESSENTIALS)	0.00	0.00	1	\$0.00
Cisco	C9800L-RMNT	C9800 Wireless Controller Rack Mount Tray	225.00	108.00	1	\$108.00
Cisco	C9800-AC-110W	Cisco Catalyst 9800 L Wireless Controller Power Supply	0.00	0.00	1	\$0.00
Cisco	CAB-AC-C5	AC Power Cord, Type C5, US, Canada	0.00	0.00	1	\$0.00
FluxLight	SFP-10G-SR	10 Gigabit Short Reach SFP+	995.00	150.00	2	\$300.00
MI		Installation and Configuration			1	\$1,000.00

9800-L Total

\$7,248.00

Total

\$90,122.40

Approved by USAC

\$72,559.40

Action Sheet

MEETING DATE:

December 16, 2020

AGENDA ITEM:

Discuss and consider approval of payment of attorney fees.

The Board has directed that attorney fees incurred by the district be brought for approval before payments are made. The district is in receipt of invoices from:

Karczewski | Bradshaw | Spalding

General Legal Matters:	\$4,525.00	Invoice #2021086 (December 7 for November)
Real Estate Matters:	\$1,135.00	Invoice #2021087 (December 7 for November)
Special Education Matters:	\$147.50	Invoice #20204992 (December 7 for November)
Hearing:	\$0	

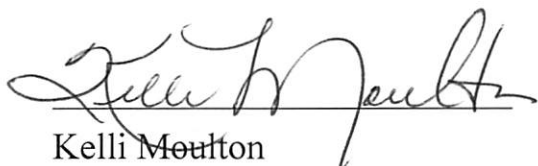

Kelli Moulton
Superintendent

Action Sheet

MEETING DATE:

December 16, 2020

AGENDA ITEM:

Discuss and consider approval of \$8,164 Change Order Increase to JW Kelso's contract for Crenshaw and MS Campus Improvements

In 2019, the Board approved a \$686,982 contract with JW Kelso for Crenshaw and Middle School improvements. After project completion, the board approved a deductive change order for \$18,551. Recently; however, it became necessary to infill cavities and crevices with spray foam under Crenshaw in area where two of the concrete columns are close together creating a perfect nesting area for birds. This change order will address this area by filling in the cavity to ensure the birds don't nest and damage the foam insulation.

This is an increase to the contract in the amount of \$8,164, for a final project cost of \$676,595.

RECOMMENDATION:

I move that the board approve the \$8,164 change order increase to JW Kelso's contract for Crenshaw and MS Campus Improvements, as presented.

Kelli Moulton
Superintendent



Connie Morgenroth
Assistant Superintendent of Business & Operations



AIA® Document G701™ – 2017

Change Order

PROJECT: <i>(Name and address)</i> Crenshaw Elementary and Middle School Campus Improvements 416 State Hwy 87, Crystal Beach, TX 77650	CONTRACT INFORMATION: Contract For: General Construction Date: April 11, 2019	CHANGE ORDER INFORMATION: Change Order Number: 002 Date: December 2, 2020
OWNER: <i>(Name and address)</i> Galveston Independent School District 3904 Avenue T Galveston, Texas 77550	ARCHITECT: <i>(Name and address)</i> PBK Architects Inc. 11 E. Greenway Plaza, 22nd Floor Houston, Texas 77046	CONTRACTOR: <i>(Name and address)</i> J.W. Kelso Company Inc. 7225 Harborside Drive Galveston, Texas 77554

THE CONTRACT IS CHANGED AS FOLLOWS:

(Insert a detailed description of the change and, if applicable, attach or reference specific exhibits. Also include agreed upon adjustments attributable to executed Construction Change Directives.)

Added Scope of Work to Fill Cavities for Increased Bird Protection.

The original Contract Sum was	\$	686,982.00
The net change by previously authorized Change Orders	\$	-18,551.00
The Contract Sum prior to this Change Order was	\$	668,431.00
The Contract Sum will be increased by this Change Order in the amount of	\$	8,164.00
The new Contract Sum including this Change Order will be	\$	676,595.00

The Contract Time will be increased by Zero (0) days.
The new date of Substantial Completion will be July 31, 2019

NOTE: This Change Order does not include adjustments to the Contract Sum or Guaranteed Maximum Price, or the Contract Time, that have been authorized by Construction Change Directive until the cost and time have been agreed upon by both the Owner and Contractor, in which case a Change Order is executed to supersede the Construction Change Directive.

NOT VALID UNTIL SIGNED BY THE ARCHITECT, CONTRACTOR AND OWNER.

PBK Architects Inc. ARCHITECT <i>(Firm name)</i>	J.W. Kelso Company Inc. CONTRACTOR <i>(Firm name)</i>	Galveston Independent School District OWNER <i>(Firm name)</i>
 SIGNATURE	 SIGNATURE	 SIGNATURE
Manuel Torres, Principal PRINTED NAME AND TITLE	Zach Williams, Vice President PRINTED NAME AND TITLE	Connie Morgenroth, Assistant Superintendent of Business & Operations PRINTED NAME AND TITLE
 DATE	 DATE	 DATE



J. W. Kelso Company, Inc.
P.O. Box 2110, Galveston, Texas 77553
7225 Harborside Drive, Galveston, Texas 77554
Phone: 409-740-0266
Fax: 409-740-0268

June 26, 2020

Paul Byers
GISD
4302 Avenue Q
Galveston, TX 77550

Re: Crenshaw ES/MS Campus Improvements GISD
CP#5 Fill Cavities for Added Bird Protection

Dear Mr. Byers,

To provide labor and material for the above mentioned project will cost a total sum of **\$8,164.00** per the following scope of work.

- Infill crevices with spray foam material for added bird protection.

Please do not hesitate to call if there are any questions.

Sincerely,
J.W. Kelso Co., Inc.

Lee Hughes
Project Manager

Batt and Rigid Building Insulation
Acoustic and Thermal Insulation
Firestop and Penetration Seals
Spray-On Fireproofing



Waterproofing & Damproofing
Spray-On Polyurethane Foam
Spray-On Insulation
Caulking & Sealants

SERVING HOUSTON AND CENTRAL TEXAS SINCE 1991

06/26/2020

Ref# 12719

ATTN: Lee Hughs

Email: lhughes@jwkelso.com

RE: Add Foam Insulation In Crevices

1. Divots will be filled back to proper thickness and touched up with its respective ignition to match existing. After the sprinklers get adjusted by others. No cost
2. Spray foam be sprayed to full depth crevices where insulation has been removed or used by the birds to create some kind of nests. Includes Foam and Ignition barrier.

\$3,512.00 Material & Misc Items

\$1,100.00 Equipment-(Generator & Lift)

\$1,440.00 48 Hours Labor Rate @ \$30.00

\$6,052.00 Subtotal

\$ 908.00 15% Over Head & Profit

TOTAL CHANGE ORDER PRICING: \$6,960.00

Please feel free to contact me with any further questions or concerns regarding this Change Order.

Thank you,

Israel Sahagun

Project Manager

Fireproof Contractors Inc.

Houston
4255 Clay Business Drive
Katy, TX 77449
(713) 690-7600
Fax: (713) 690-7635

www.fireproofcontractors.com

161

Central Texas
P.O. Box 2670
San Marcos, TX 78667
(512) 997-7600
Fax: (512) 997-7677

Action Sheet

MEETING DATE:

December 16, 2020

AGENDA ITEM:

Discuss and consider approval for construction of Crenshaw outdoor environmental classroom as outlined in APEX 3 Magnet Grant. Amount not to exceed \$57,500 using Grant funds.

The Crenshaw outdoor classroom would be ideal for environmental studies. All grade levels of students from Kindergarten to 8th grade would use the classroom to gather data about observations that revolves around Environmental Science. Learning would provide authentic experiences every day. This would be one of the most engaging schools around. Students would be learning through hands-on experiences and growing a love for the Environmental Science opportunities of a lifetime. Funding for this project is from APEX 3 Magnet Grant.

RECOMMENDATION:

I move that the Board of Trustees approve the construction of Crenshaw's outdoor classroom using APEX 3 Magnet Grant Funds for an amount not to exceed \$57,500.

Kelli Moulton
Superintendent

Annette Scott
Assistant Superintendent for
Curriculum & Instruction

FRAME

**INCOMPLETE
NOT FOR
CONSTRUCTION**

ISSUED 03/05/2018

PROJECT INFO

- CLIENT
ARTIST BOAT
- LOCATION
GALVESTON ISLAND, TX
- ARCHITECT
COLEMAN COKER
- STRUCTURAL ENGINEER
NORM HOFFMAN

DESIGN TEAM

- PEIWEI CHANG
- PIA GARCIA
- MAGGIE GAUDIO
- DANLIN HUANG
- SUDARSHAN IYENGAR
- REUBEN JOSEPH
- MIGUEL RODRIGUEZ
- JORDAN SHEETS
- DEREK SMITH
- ANDREW STONE
- BRANDON THARP
- CLAIRE TOWNLEY
- ANGELA VANELLA

SHEET INFO

DRAWN BY: Author

PROJECT NORTH: 

COVER SHEET

A1.1

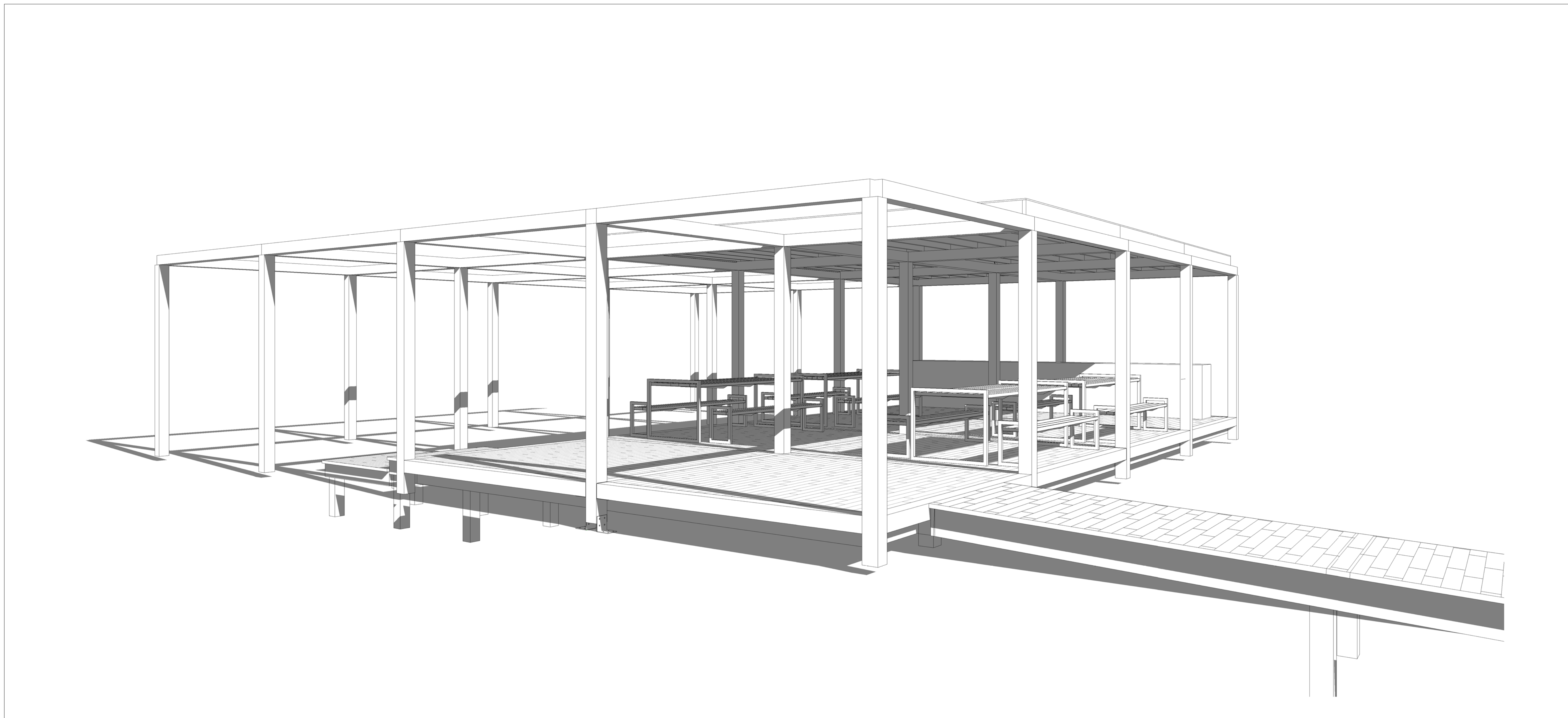

OWNER: ARTIST BOAT

GALVESTON, TX 77550
PHONE: (409) 770 - 0722
CONTACT: KARLA KLAY
ARTIST BOAT
2627 AVE O
GALVESTON, TX 77550

STRUCTURAL ENGINEER

IBIS ENGINEERING
1119 Ball St
Galveston, TX 77550
PHONE: (409) 621 - 6740
CONTACT: NORM HOFFMAN

ARCHITECT OF RECORD

THE UNIVERSITY OF TEXAS AT AUSTIN
310 INNER CAMPUS DRIVE B7500
AUSTIN, TX 78712-1009
PHONE: (512) 471 - 1922
CONTACT: COLEMAN COKER
EMAIL: CCOCKER@AUSTIN.UTEXAS.EDU

LOCAL COORDINATING ARCHITECT

BRAX EASTERWOOD DESIGN
2728 AVENUE Q - SUITE 2
GALVESTON, TX 77550
PHONE: (409) 354 - 8976
CONTACT: BRAX EASTERWOOD

CODE DATA

1. APPLICABLE CODES:
2012 INTERNATIONAL BUILDING CODE (IBC)

2012 TEXAS ACCESSIBILITY STANDARDS

2010 ADA STANDARDS FOR ACCESSIBLE DESIGN

2013 ARCHITECTURAL BARRIERS ACT,
ACCESSIBILITY GUIDELINES FOR OUTDOOR
DEVELOPED AREAS ON FEDERAL LANDS
2. YEAR CONSTRUCTED: 2018
3. USE AND OCCUPANCY CLASSIFICATION: A-3
4. CONSTRUCTION CLASSIFICATION: V-B
5. NUMBER OF STORIES:
1 ABOVE GRADE PLANE
MAX ALLOWABLE FOR TYPE V-B PER TABLE
503: 2 STORIES
6. BUILDING HEIGHT: 10'-10"
7. TOTAL BUILDING AREA: 800 SF
8. BUILDING WILL NOT BE SPRINKLERED
9. OCCUPANCY:
800 SF STANDING SPACE / 5 SF PER OCCUPANT
(PER TABLE 1004.1.2) = 160 OCCUPANTS

INDEX

Sheet List	
Sheet Number	Sheet Name
A1.1	COVER SHEET
A1.2	SITE PLAN
A2.1	FLOOR PLAN
A2.2	FRAMING PLANS - FLOOR
A2.3	FRAMING PLANS - ROOF
A3.1	BUILDING ELEVATIONS
A3.2	BUILDING SECTIONS
A4.1	DETAILS
A4.2	DETAILS
A5.3	DETAILS
A6.1	FURNITURE DETAILS
A6.2	FURNITURE DETAILS

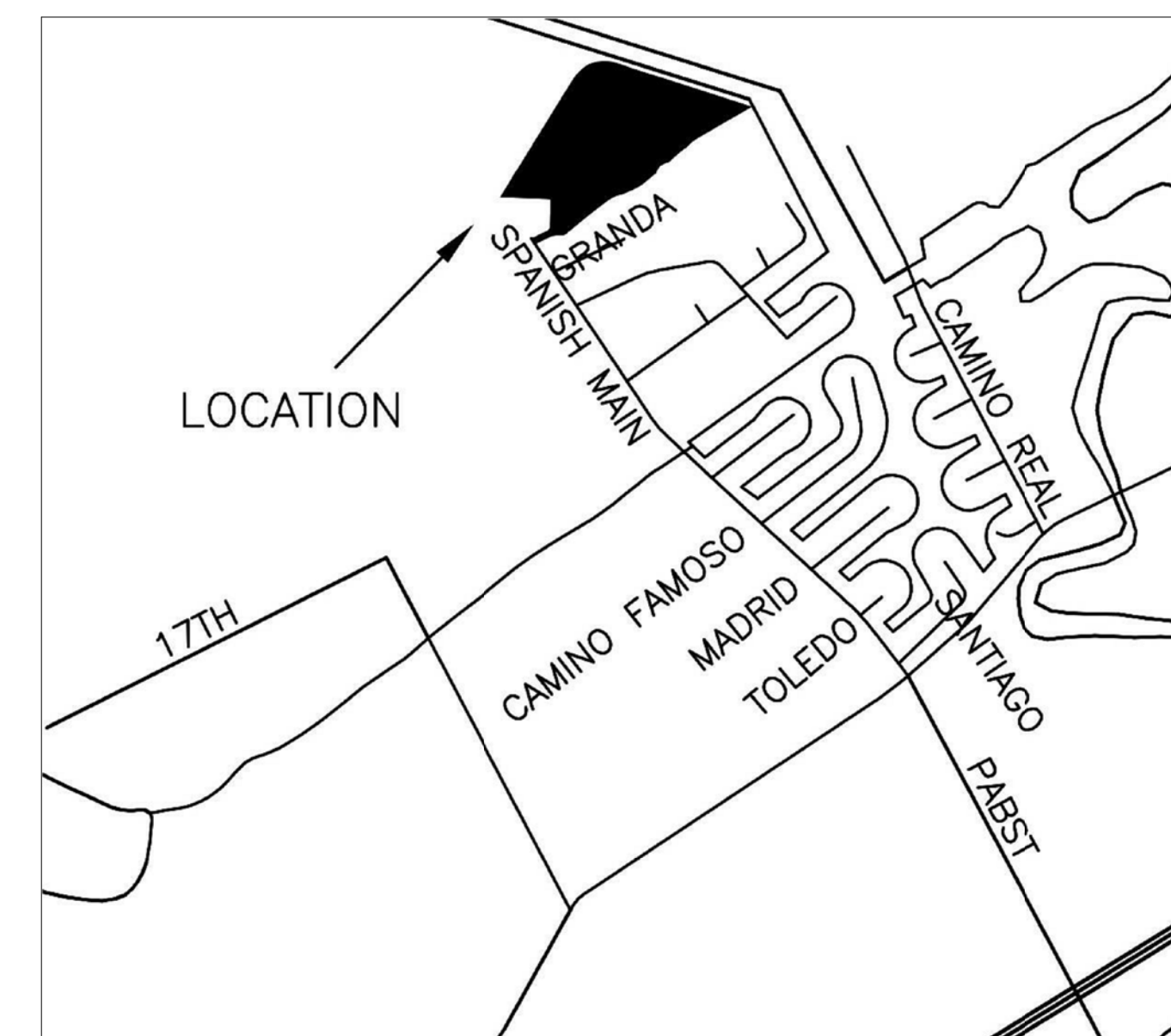

VICINITY MAP

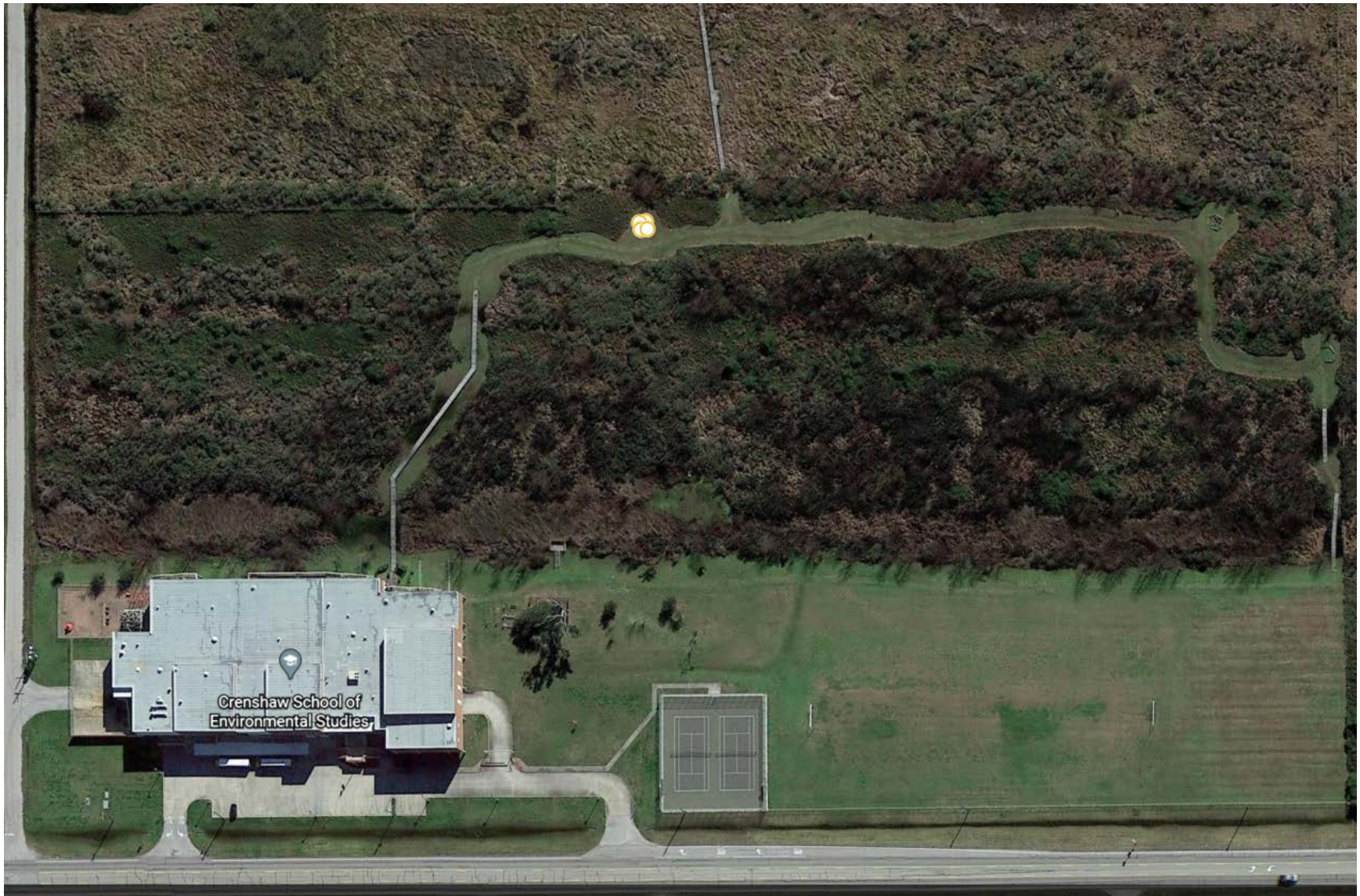













Action Sheet

MEETING DATE: December 16, 2020

AGENDA ITEM: Discuss and consider approval of resolution to extend use of sick leave in accordance with the FFCRA

Effective April 1, 2020, the federal government passed the Families First Coronavirus Response Act (FFCRA). The FFCRA required GISD and other certain employers to provide their employees with up to 80 hours of paid sick leave, in addition to expanded family and medical leave for specified reasons related to COVID-19. The provisions of the act will expire December 31, 2020.

GISD, along with other area school districts, realize the need to continue this paid sick leave in accordance to the specific terms of the FFCRA until May 28, 2021, the end of the 2021 school year. Extending this leave serves the public purpose of protecting students and staff, maintaining morale, and reducing turnover.

RECOMMENDATION: I move that the board approve the resolution to extend the use of sick leave in accordance with the FFCRA, as presented.



Kelli Moulton
Superintendent



Connie Morgenroth
Assistant Superintendent of Business & Operations

**Resolution of the Galveston Independent School District Board of Trustees Regarding
Extension of Time to Use Sick Leave in Accordance with the Families First
Coronavirus Response Act**

WHEREAS, the Families First Coronavirus Response Act (FFCRA) requires the Galveston Independent School District to provide its employees with up to 80 hours of paid sick leave for specified reasons related to COVID-19; and

WHEREAS, the entitlement of GISD employees to up to 80 hours of sick leave under the provisions of the FFCRA apply from April 1, 2020 through December 31, 2020; and

WHEREAS, the Board finds that a need exists to extend until the end of the 2020-2021 school year the ability of employees to avail themselves of up to 80 hours of paid sick leave in accordance with the terms of the FFCRA; and

WHEREAS, the Board concludes that an extension of time through May 28, 2021, the end of the 2020-2021 school year, for employees to use up to 80 hours of paid sick leave according to the terms of the FFCRA serves the public purposes of protecting students and staff, maintaining morale, and reducing turnover.

NOW, THEREFORE, BE IT RESOLVED that the Board of Trustees of the Galveston Independent School District authorizes allowing employees until May 28, 2021, the end of the 2020-2021 school year, to use up to 80 hours of paid sick leave according to the terms of the FFCRA.

Approved this 16th day of December 2020, by the Galveston ISD Board of Trustees.

By:

Anthony Brown, Board President

Attest:

Monica Wagner, Board Secretary

Action Sheet

MEETING DATE: December 16, 2020

AGENDA ITEM: Discuss and consider purchase of 4 school buses in an amount not to exceed \$469,976.

The District recommends the purchase of four (4) 77 passenger, 2022 International ICE diesel school buses at a cost of \$117,294.00 each, plus an additional \$800.00 Buy Board Fee (Buy Board Contract #549-17), for a total cost of \$469,976. These buses are equipped with the following safety features:

- Bendix Wingman Fusion Collision Mitigation system (with radar and camera)
 - Lane departure warning
 - Stability control to prevent rollover
 - Stationary object emergency braking to avoid front end collisions
 - Adaptive driving to apply brake and throttle retarder to maintain safe following distance
- Rosco 360 degree camera system
 - Allows for a full 360 degree view in the driver's rearview mirror
 - Operates side view of vehicle when turn signals are applied
 - Operates rear view of vehicle when "reverse" is selected in transmission
 - Operates front view of vehicle when service door is opened for loading and unloading
- 3 point seatbelts

The four new buses will replace three (3) 2008 International school buses and one (1) 2010 Thomas school bus. These older buses are currently out of service due to costly repairs and have been used as "part buses". This purchase will begin the replacement cycle for school buses; if the District can purchase 3 buses per year for the next three years, we will be on track to replace two buses per year after that.

RECOMMENDATION:

I move that the board approve the purchase of 4 school buses for an amount not to exceed \$469,976, as presented.



Kelli Moulton
Superintendent



Connie Morgenroth
Assistant Superintendent of Business & Operations



INTEGRATED CE S BUS

Sales Proposal For:
Galveston ISD

Presented By:
LONGHORN BUS SALES

Prepared For:
Galveston ISD
Mike Praker
3101 83rd st.
Galveston, TX 77554-
(409)740 - 1208
Reference ID: 4-77P DSL 3PT

Presented By:
LONGHORN BUS SALES
LINDA BLUME
9100 N LOOP E
HOUSTON TX 77029 -
(713)631-9306

Thank you for the opportunity to provide you with the following quotation on a new IC Corporation vehicle. I am sure the following detailed specification will meet your operational requirements, and I look forward to serving your business needs.

Model Profile
2022 INTEGRATED CE S BUS (PB105)

APPLICATION:	School Transportation
MISSION:	Requested GVWR: 29800. Calc. GVWR: 31000 Calc. Start / Grade Ability: 26.96% / 1.85% @ 55 MPH Calc. Geared Speed: 79.2 MPH
DIMENSION:	Wheelbase: 276.00, CA: N/A, Axle to Frame: 166.00
ENGINE, DIESEL:	{Cummins B6.7 240} EPA 2021, 240HP @ 2400 RPM, 560 lb-ft Torque @ 1600 RPM, 2600 RPM Governed Speed, 240 Peak HP (Max), School Bus Only
TRANSMISSION, AUTOMATIC:	{Allison 2500 PTS} 5th Generation Controls, Wide Ratio, 6-Speed with Double Overdrive, Less PTO Provision, Less Retarder, with 33,000-lb GVW and GCW Max, School Bus
CLUTCH:	Omit Item (Clutch & Control)
AXLE, FRONT NON-DRIVING:	{Meritor MFS-10-122A} I-Beam Type, 10,000-lb Capacity
AXLE, REAR, SINGLE:	{Dana Spicer S140} Single Reduction, 21,000-lb Capacity, 190 Wheel Ends Gear Ratio: 6.14
TIRE, FRONT:	(2) 11R22.5 Load Range H X MULTI ENERGY Z (MICHELIN), 501 rev/mile, 75 MPH, All-Position
TIRE, REAR:	(4) 11R22.5 Load Range H X MULTI ENERGY Z (MICHELIN), 501 rev/mile, 75 MPH, All-Position
SUSPENSION, REAR, AIR, SINGLE:	{International IROS} 21,000-lb Capacity, 9.25" Ride Height, with Shock Absorbers
PAINT:	Cab schematic 100NB Location 1: 4421, School Bus Yellow (Std) Chassis schematic N/A

Vehicle Specifications
2022 INTEGRATED CE S BUS (PB105)

December 01, 2020

Code	Description
PB10500	Base Chassis, Model INTEGRATED CE S BUS with 276.00 Wheelbase, N/A CA, and 166.00 Axle to Frame.

BODY PLANS

47AMG	BODY, BUS Conventional; 78" Headroom, 34'11" Body Length, +9 Section Rear, 78 Passenger, 276 WB <u>Includes</u> : NOTE: Body Mandates Overall Vehicle Length of Greater than 40 Feet
50UCJ	BODY PLAN, NON-SPECIAL NEEDS Conventional; 34' 11" Body Length, +9 Section Rear, 77 Passenger, 276" WB, DX9386A000
49001	BODY PLAN, APPROVED VARIATION Number 001

ENGINE

12ERS	ENGINE, DIESEL {Cummins B6.7 240} EPA 2021, 240HP @ 2400 RPM, 560 lb-ft Torque @ 1600 RPM, 2600 RPM Governed Speed, 240 Peak HP (Max), School Bus Only
12UYE	RADIATOR Aluminum, 2-Row, Cross Flow, Over Under System, 717 SqIn Louvered, with 313 SqIn Charge Air Cooler, Includes In-Tank Oil Cooler <u>Includes</u> : DEAERATION SYSTEM with Surge Tank : HOSE CLAMPS, RADIATOR HOSES Gates Shrink Band Type; Thermoplastic Coolant Hose Clamps : RADIATOR HOSES Premium, Rubber
12TSY	FAN DRIVE {Borg-Warner SA85} Viscous Type, Screw On <u>Includes</u> : FAN Nylon
12VBR	AIR CLEANER with Service Protection Element <u>Includes</u> : GAUGE, AIR CLEANER RESTRICTION Air Cleaner Mounted
12703	ANTI-FREEZE Red, Extended Life Coolant; To -40 Degrees F/ -40 Degrees C, Freeze Protection
12VVN	CRUISE CONTROL Electronic <u>Notes</u> : Cruise Control Switches Mounted on Steering Wheel are Non-Illuminated.
12WZE	EMISSION COMPLIANCE Federal, Does Not Comply with California Clean Air Idle Regulations
12VHP	FEDERAL EMISSIONS {Cummins B6.7} EPA, OBD and GHG Certified for Calendar Year 2021
12VWH	GOVERNOR Electronic Road Speed Type; for Electronic Engines and Bus Models; with 55 MPH Default
12VYV	IDLE MANAGEMENT SYSTEM Ramp Engine Speed with Air Condition On, in Neutral and Parking Brake Set, Accommodation Package
12UGN	THROTTLE, HAND CONTROL Electronic <u>Notes</u> : Cruise Control Switches Mounted on Steering Wheel are Non-Illuminated.

TRANSMISSION

13ARV	TRANSMISSION, AUTOMATIC {Allison 2500 PTS} 5th Generation Controls, Wide Ratio, 6-Speed with Double Overdrive, Less PTO Provision, Less Retarder, with 33,000-lb GVW and GCW Max, School Bus <u>Includes</u> : OIL FILTER, TRANSMISSION Mounted on Transmission
-------	---

Vehicle Specifications
2022 INTEGRATED CE S BUS (PB105)

December 01, 2020

Code	Description
	: TRANSMISSION OIL PAN Magnet in Oil Pan
13WYY	SHIFT CONTROL PARAMETERS {Allison} 1000 or 2000 Series Transmissions, Performance Programming
13WLN	TRANSMISSION OIL Synthetic; 20 thru 28 Pints

CLUTCH

11001	CLUTCH Omit Item (Clutch & Control)
-------	-------------------------------------

REAR AXLES, SUSPENSIONS

14AKC	AXLE, REAR, SINGLE {Dana Spicer S140} Single Reduction, 21,000-lb Capacity, 190 Wheel Ends . Gear Ratio: 6.14
14TBS	SUSPENSION, REAR, AIR, SINGLE {International IROS} 21,000-lb Capacity, 9.25" Ride Height, with Shock Absorbers
	<u>Notes</u> : The following features should be considered when calculating Rear GAWR: Rear Axles; Rear Suspension; Brake System; Brakes, Rear Air Cam; Brake Shoes, Rear; Special Rating, GAWR; Wheels; Tires.

FRONT AXLES

2ASH	AXLE, FRONT NON-DRIVING {Meritor MFS-10-122A} I-Beam Type, 10,000-lb Capacity
	<u>Includes</u> : AXLE, FRONT SQUARING to Plus or Minus .015 Inch, using a Special Fixture to Assure Parallelism of Springs
	<u>Notes</u> : The following features should be considered when calculating Front GAWR: Front Axles; Front Suspension; Brake System; Brakes, Front Air Cam; Wheels; Tires.

FRONT SUSPENSIONS

3ADB	SUSPENSION, FRONT, SPRING Parabolic Taper Leaf, Shackle Type, 10,000-lb Capacity, with Shock Absorbers
	<u>Includes</u> : SPRING PINS Bolt and Nut Type : SPRING PINS Rubber Bushings, Maintenance-Free
	<u>Notes</u> : The following features should be considered when calculating Front GAWR: Front Axles; Front Suspension; Brake System; Brakes, Front Air Cam; Wheels; Tires.

CABS, COWLS, BODIES

16010	COWL Flat Back
16HBA	GAUGE CLUSTER English with English Electronic Speedometer
	<u>Includes</u> : GAUGE CLUSTER (5) Engine Oil Pressure (Electronic), Water Temperature (Electronic), Fuel (Electronic), Tachometer (Electronic), Voltmeter : ODOMETER DISPLAY, Miles, Trip Miles, Engine Hours, Trip Hours, Fault Code Readout : WARNING SYSTEM Low Fuel, Low Oil Pressure, High Engine Coolant Temp, and Low Battery Voltage (Visual and Audible)
16HLJ	GAUGE, DEF FLUID LEVEL
16HGH	GAUGE, OIL TEMP, AUTO TRANS for Allison Transmission

Vehicle Specifications
2022 INTEGRATED CE S BUS (PB105)

December 01, 2020

Code	Description
16HKT	IP CLUSTER DISPLAY On Board Diagnostics Display of Fault Codes in Gauge Cluster

FRAMES

1CAC	FRAME RAILS High Strength Low Alloy Steel (50,000 PSI Yield); 10.125" x 3.062" x 0.312" (257.2mm x 77.8mm x 8.0mm); 480.1" (12195mm) Maximum OAL <u>Includes</u> : CHASSIS PAINT Chassis Painted Prior to Body Mounting : FRAME RAILS All holes Laser Aligned and Machine Punched, Powder Coated Prior to Full Assembly, Assembled in Fixture using "Grade 8" Bolts : FRAME REINFORCEMENT, SPECIAL 3.30" x 1.80" x 0.312" x 31.50" Inverted "L" in Front Shock Absorber Mounting Area
1LTV	BUMPER, FRONT Contoured, Steel, Heavy Duty
1LNT	CROSSING GATE, FRONT Omit Item <u>Includes</u> : CROSSING GATE, FRONT Matches Contour of Bumper
1SAM	CROSSMEMBER, REAR, AF (2)
1WJE	WHEELBASE RANGE 276" (700cm) Only

BRAKES

4091	BRAKE SYSTEM, AIR Dual System for Straight Truck Applications <u>Includes</u> : BRAKE LINES Color and Size Coded Nylon : DRAIN VALVE Twist-Type : GAUGE, AIR PRESSURE (2) Air 1 and Air 2 Gauges; Located in Instrument Cluster : PARKING BRAKE CONTROL Yellow Knob, Located on Instrument Panel : PARKING BRAKE VALVE For Truck : QUICK RELEASE VALVE On Rear Axle for Spring Brake Release: 1 for 4x2, 2 for 6x4 : SPRING BRAKE MODULATOR VALVE R-7 for 4x2, SR-7 with relay valve for 6x4/8x6 <u>Notes</u> : Rear Axle is Limited to 19,000-LB GAWR with Code 04091 BRAKE SYSTEM, AIR and Code 04NDC BRAKES, REAR, AIR CAM Regardless of Axle/Suspension Ordered : Rear Axle is Limited to 20,000-LB GAWR with Code 04092 BRAKE SYSTEM, AIR and Code 04NCW BRAKES, REAR, AIR CAM Regardless of Axle/Suspension Ordered
4AZS	AIR BRAKE ABS {Bendix AntiLock Brake System} 4-Channel (4 Sensor/4 Modulator) Electronic Stability Program, with Automatic Traction Control
4XDD	BRAKES, FRONT {Meritor 15X5 Q-PLUS CAST} Air S-Cam Type, Cast Spider, Fabricated Shoe, Double Anchor Pin, Size 15" X 5", 13,200-lb Capacity
4EXP	BRAKE CHAMBERS, FRONT AXLE {Bendix} 20 Sqli
4LAG	SLACK ADJUSTERS, FRONT {Gunite} Automatic
4XDR	BRAKES, REAR {Meritor 16.5X7 Q-PLUS CAST} Air S-Cam Type, Cast Spider, Fabricated Shoe, Double Anchor Pin, Size 16.5" X 7", 23,000-lb Capacity per Axle
4EXU	BRAKE CHAMBERS, REAR AXLE {Bendix EverSure} 30/30 Sqli Spring Brake
4SPA	AIR COMPRESSOR {Cummins} 18.7 CFM
4EBS	AIR DRYER {Bendix AD-9} with Heater

Vehicle Specifications
2022 INTEGRATED CE S BUS (PB105)

December 01, 2020

Code	Description
4VCY	AIR TANK LOCATION (1) Mounted Left Side to Provide Clearance for Larger Body Builder Supplied Battery Box
4722	DRAIN VALVE {Bendix DV-2} Automatic, with Heater, for Air Tank
4WZT	GVWR LIMITATION FOR BUS with Air Brakes, Limited to 33,000-lbs Maximum to meet FMVSS 121 Requirements, for Conventional Bus
4LGG	SLACK ADJUSTERS, REAR {Gunite} Automatic

STEERING

5PSA	STEERING GEAR {Sheppard M100} Power
5708	STEERING COLUMN Tilting
5CAL	STEERING WHEEL 2-Spoke, 18" Dia., Black

DRIVELINES

6DGA	DRIVELINE SYSTEM {Dana Spicer} SPL100, for 4x2/6x2
------	--

EXHAUST SYSTEMS

7BMK	EXHAUST SYSTEM Horizontal Aftertreatment System, Frame Mounted Under Right Rail, for Single Long Horizontal Tail Pipe
7SCP	ENGINE EXHAUST BRAKE for Cummins ISB/B6.7/ISL/L9 Engine with Variable Vane Turbo Charger
7WBL	TAIL PIPE (1) Horizontal, Long, Exits Left Side Through Bumper

ELECTRICAL SYSTEMS

8000	ELECTRICAL SYSTEM 12-Volt, Standard Equipment <u>Includes</u> : HAZARD SWITCH Push On/Push Off, Located on Top of Steering Column Cover : HEADLIGHT DIMMER SWITCH Integral with Turn Signal Lever : MISCELLANEOUS FEATURES Modular, Loom Protected, Grommets in all Applicable Body Openings, Assembled in Computer Assisted Fixture which Verifies Continuity and Correct Assembly Prior to Installation : PARKING LIGHT Integral with Front Turn Signal and Rear Tail Light : STARTER SWITCH Electric, Key Operated : TURN SIGNAL FLASHER : TURN SIGNAL SWITCH Self-Cancelling with Lane Change Feature : TURN SIGNALS, FRONT Includes Reflectors; Flush Mounted : WINDSHIELD WIPER SWITCH 2-Speed with Wash and Intermittent Feature (5 Pre-Set Delays), Integral with Turn Signal Lever : WIRING, CHASSIS Color Coded and Continuously Numbered
8GXK	ALTERNATOR {Leece-Neville BLP4006HN} Brushless, 12 Volt, 325 Amp Capacity, Pad Mount, with Remote Sense
8TTK	BATTERY BOX Steel, with Sliding Tray, 25.25" Wide, for Standard Batteries, 1-3 Battery Capacity, Mounted Left Side Behind Front Axle Perpendicular to Frame Rail
8MSG	BATTERY SYSTEM {Fleetrite} Maintenance-Free, (3) 12-Volt 1980CCA Total, Top Threaded Stud
8XAH	CIRCUIT BREAKERS Manual-Reset (Main Panel) SAE Type III with Trip Indicators, Replaces All Fuses

Vehicle Specifications
2022 INTEGRATED CE S BUS (PB105)

December 01, 2020

Code	Description
8TPU	COLLISION MITIGATION SYSTEM {Bendix Wingman Fusion} Adaptive Cruise Control w/Collision Mitigation & Stationary Vehicle Braking, Stationary Object Alert, Lane Departure Warning, Overspeed Alert & Action; Includes Front Radar & Camera, Driver Display, Lane Departure Warning Switch & Speakers; Safety Direct Capability, less Safety Direct Cable
8WXB	HEADLIGHT WARNING BUZZER Sounds When Head Light Switch is on and Ignition Switch is in "Off" Position
8WPB	HEADLIGHTS Halogen, Composite Aero Design, with Daytime Running Lights
8WZL	HEADLIGHTS, WIG WAG with Bus Pupil Warning Lights
8VAZ	HORN, ELECTRIC (2) Trumpet Style, Mounted on Top of Mega-Bracket
8WWJ	INDICATOR, LOW COOLANT LEVEL with Audible Alarm
8XKL	STARTING MOTOR {Mitsubishi Electric Automotive America 90P47} 12-Volt, with Soft-Start
8VZK	TURN SIGNALS, FRONT Dual Face, LED, Amber/Red, Mounted on Top of Fender, Used with Standard Flush Mounted Front Turn Signal, Side Marker Lamps, Parking Lights and Reflectors

FRONT END

9WAY	FRONT END Tilting, Fiberglass, with Three Piece Construction <u>Includes</u> : AIR INTAKE SYSTEM Integrated Pre-Cleaning System to Enhance Air Filter Life : GRILLE Removable; Fiberglass Painted Hood Color : SPLASH SHIELD Integral with Front End Assembly
9HCW	GRILLE Molded in Black
9WAB	HOOD TILT ASSIST {EASY TILT} Mechanical
9AAE	LOGOS EXTERIOR, ENGINE Badges

SPEEDOMETER, TOOLS, MISC

10020	CHASSIS PAINT Full Chassis
10060	PAINT SCHEMATIC, PT-1 Single Color, Design 100 <u>Includes</u> : PAINT SCHEMATIC ID LETTERS "NB"
10788	PAINT TYPE Urethane, One or Two Colors, Other than Imron or International.
10XAK	PROMOTIONAL PACKAGE 7 Year Unlimited Miles/km Warranty, Limited Time Program for Allison 2500 Series Transmission on School and Commercial Buses (Supplied directly through Allison)
10DAS	PROMOTIONAL PKG, CORR RESIST Corrosion Resistant Bus
10XAH	PROMOTIONAL PACKAGE LED INTR {Sound Off/OptiLuxx} LED Lights
10XAJ	PROMOTIONAL PACKAGE LED EXT {Sound Off/OptiLuxx} LED Lights

FUEL TANKS

15SJT	FUEL TANK Top Draw, Steel, Rectangular, 100 US Gal (379L), Includes Protective Cage, with Low Profile Fuel Filler Assembly and Vent Hosing, Mounted Between Frame Rails and Behind Rear Axle
15WEP	DEF TANK 16.5 US Gal (62.5L) Capacity, Frame Mounted Outside Right Rail, Behind 0 Bow

WHEELS, TIRES - FRONT

Vehicle Specifications
2022 INTEGRATED CE S BUS (PB105)

December 01, 2020

Code	Description
27DUW	WHEELS, FRONT {Accuride 51408} DISC; 22.5x8.25 Rims, Powder Coat Steel, 2-Hand Hole, 10-Stud, 285.75mm BC, Hub-Piloted, Flanged Nut, with Steel Hubs
7482133285	(2) TIRE, FRONT 11R22.5 Load Range H X MULTI ENERGY Z (MICHELIN), 501 rev/mile, 75 MPH, All-Position

WHEELS, TIRES - REAR

28DUW	WHEELS, REAR {Accuride 51408} DUAL DISC; 22.5x8.25 Rims, Powder Coat Steel, 2-Hand Hole, 10-Stud, 285.75mm BC, Hub-Piloted, Flanged Nut, with Steel Hubs
7482133285	(4) TIRE, REAR 11R22.5 Load Range H X MULTI ENERGY Z (MICHELIN), 501 rev/mile, 75 MPH, All-Position

WHEELS MISC OPTIONS

29580	WHEEL SEALS, FRONT {International} Oil-Lubricated Wheel Bearings
-------	--

BODY FEATURES

47BAK	BUMPER, REAR Painted, 12" High, 3/16" Thick
47BAR	SUPPORTS, REAR BUMPER Bolted to Frame
47AYB	BODY, REAR Includes Emergency Door <u>Includes</u> : DOOR, REAR EMERGENCY with Concealed Hinges : HEADER BUMPER Padded, Mounted Over Rear Door; Upholstered to Match Passenger Seat Color
47ARH	BOWS, ROOF 14 ga., One Piece Construction <u>Includes</u> : BOWS, ROOF Positioned Floor Line to Floor Line, Threaded Through Roof Strainers and Drip Rail
47BLU	FASTENERS, EXTERIOR MOUNTED Stainless Steel Screws; for All Exterior Body Lights, Fenders, Body Exterior Rear View Mirrors, Bumper Mounted Crossing Gate and Body Mounted Stop Arm
47DXG	FASTENERS, HANDRAIL Plusnuts & Screws
47APX	FASTENERS, HEADLINER Screws
47AZL	FLOOR, BODY with Wheel Wells
47PCA	HANDLE, ASSIST Windshield Side Mounted, Left and Right, Stainless Steel, 4 Point Mount
47APR	HEADLINER, BODY Conventional; 25'11"-34'11" Body Length, Perforated Full Length with Sound Insulation Full Length
47ARP	LIGHT BARS Plastic
47BBH	LINING, SIDE INTERIOR, LOWER Embossed Steel, Clear Coated
47AXT	RUB RAILS, BODY (4) Conventional; Steel, 31'2", 31'11", 32'8", 33'5", 34'2", 34'11", Body Length, Includes Snow Rail <u>Includes</u> : RUB RAILS Full Length, Primer Coated (Both Sides), Attached to Body without Cuts or Splices
47BBZ	SEALER Extra; Sidewall to Floor, In Wheel Pocket Area, and Rear Wall to Floor
47AZE	SIDE SHEET, BODY, EXTERIOR Conventional, 16ga., Smooth, 31'2", 31'11", 32'8", 33'5", 34'2", 34'11", Body Length
47ASG	SKIRT, BODY for Conventional, 14 1/2", 16ga

Vehicle Specifications
2022 INTEGRATED CE S BUS (PB105)

December 01, 2020

<u>Code</u>	<u>Description</u>
	<u>Includes</u> : SKIRT, BODY Extra Smooth Steel Supported by Floor Gussets
47BLD	STEP, FRONT ENTRANCE DOOR 27 1/4" Depth; 14ga Steel, Formed Treads, Naviflex Finish
47AUR	TIE DOWNS, BODY Grade 8 Bolts, Every Body Section
	<u>Includes</u> : TIE DOWNS, BODY with Formed Tab that Fits into Floor Structure to Prevent Turning
47DAJ	COVER, REAR DOOR INSIDE HANDLE Partial Coverage
47DNB	DOOR, ENTRANCE, FRONT Electric, Outward Opening, with Split Pane Glass
	<u>Includes</u> : DOOR, ENTRANCE, FRONT Aluminum Frame with Pin Style Hinges, Ball Bearing Assisted, Interchangeable Top and Bottom Glass Lock : LOCK, ENTRANCE DOOR With Key Switch
47DAK	FASTENERS, REAR DOOR Bolts and Nutserts, Rear Door To Body
47DDE	HANDLE, ASSIST, ENTRANCE DOOR Outside Entrance
47DEY	HANDLE, EXTERIOR, REAR Emergency Door; Yellow
47DDH	HOLD BACK, REAR DOOR Stationary, No Cables, with Plastic Cover
47ALP	INTERLOCK, STARTER with Key Switch, Electric Entrance Door with Locks, Outward Opening
47DDU	LATCH, REAR DOOR One Point Slide Bar, Cam Operated, with One Inch Stroke
47EWS	LOCK, ENTRANCE DOOR , Electric Close Only with Toggle Switch
47DEK	LOCK, REAR DOOR with Ignition Starter Interlock
47DRW	RELEASE, ENTRANCE DR EXTERIOR Manual Door Control Right Front Electric Entrance Door
47EVY	COMPARTMENT, LUGGAGE, LT MID 114" x 24" x 22"
	<u>Includes</u> : HINGES Rubber : LATCH, T-HANDLE, LOCKING Stainless Steel
47EWA	COMPARTMENT, LUGGAGE, RT MID 114" X 24" X 22"
47EYB	COMPARTMENT, TOOLBOX, LT FWD 13" x 15" x 25.5", with Lock
47EYE	COMPARTMENT, TOOLBOX, RT AFT 13" x 15" x 25.5", with Lock
47EBM	HOLD DOWN, BATTERY For (2) Standard Size Batteries
47LAU	INSULATION, ROOF AND SIDES 1.50", All Models
47LAT	NOISE REDUCTION, ROOF BOW Conventional; Insulation, 31'2", 31'11", 32'8", 33'5", 34'2", 34'11", Body Lengths
47MBA	UNDERCOAT, BODY Fire Resistant, Water Based, TT-C-730 Spec
	<u>Includes</u> : UNDERCOATING Performed Before and After Mounting on Chassis
47SPB	ALPHA/NUMERIC DECAL GUIDE Quantity 021-30
47MNT	ARROW, RR DOOR, INSIDE Decal; Red, .75" Stroke, Indicating Handle Direction
47MNV	ARROW, RR DOOR, OUTSIDE Decal; Black .75" Stroke, Indicating Handle Direction
47AJA	BODY CERTIFICATION TAG Metal

Vehicle Specifications
2022 INTEGRATED CE S BUS (PB105)

December 01, 2020

Code	Description
47APJ	BODY RATING TAG Metal; for State of Texas, Includes Design Capacity and Seat Capacity
47AJC	BODY TAG, METAL Capacity to Include the Total Number of Passengers
47PLX	LETTERS, DEF, I.D. Decal; "DEF ONLY", 1" Black, on DEF Filler Door
47MJR	LETTERS, DOOR, REAR Decals; "EMERGENCY DOOR", 2" Black Letters Inside and Outside
47MVA	LETTERS, HEADER Decal; "WATCH YOUR STEP", 1" Black, Above Windshield
47MRU	LETTERS, E/E WINDOW, LEFT (2) Decal Sets, "EMERGENCY EXIT", Black Inside and Outside
47NHL	LETTERS, E/E WINDOW, RIGHT (2) Decal Sets, "EMERGENCY EXIT", Black, Inside and Outside
47MAV	LETTERS, SCHOOL BUS SIDE Decal; "SCHOOL BUS"; in 8" Reflective Black Letters, Each Side
47BKK	LETTERS, SCHOOL BUS FRONT/REAR Decal; "SCHOOL BUS"; with 8" Black Reflective Letters, 3M Fluorescent Diamond Grade, Yellow On Front and Rear Cap
47MVC	LETTERS, STEPWELL Decal, "WATCH YOUR STEP", 2.5" Black, Behind Door on Step Riser
47NTE	LOGO, ROOF LINE Decal; Wing and Shield, First Body Section, Above Driver Window and Entrance Door Over Driver Window and Entrance Door
47NMG	OPERATING INSTR, REAR Decal, Inside Rear Emergency Door
47NJA	PAINT COLOR, BODY EXTERIOR 4421 School Bus Yellow
47NKR	PAINT COLOR, BODY INTERIOR Light Gray
47NJS	PAINT COLOR, BUMPER Rear, 0001 Canyon Black
47NKD	PAINT COLOR, ROOF 9219 Winter White, Beginning 5" Above Drip
47NAB	PAINT COLOR, RUB RAILS 0001 Canyon Black
47NJM	PAINT FLASHER BACKGRD 0001 Canyon Black
47NTY	PAINT HOOD AND FENDER To Match Body Exterior
47NKL	PAINT, RUB RAIL Flange to Flange
47NGJ	PAINT, WINDOW BOW CAPS 0001 Canyon Black, Side Only
47NGW	SEAL, RUB RAILS Top Edge, All Rails
47NXH	STRIPING, E/E WINDOW, LEFT {3M} (02) Perimeter, 1" Yellow Fluorescent Diamond Grade
47NWU	STRIPING, E/E WINDOW, RIGHT {3M} (02) Perimeter, 1" Yellow Fluorescent Diamond Grade
47NXN	STRIPING, PERIMETER, REAR {3M} Emergency Door, 1" Yellow Fluorescent Diamond Grade
47NWR	STRIPING, REAR END {3M} 2" Yellow Fluorescent Diamond Grade
47NWT	STRIPING, ROOF HATCH, FRONT {3M} Decal, Perimeter, 1" Yellow Fluorescent Diamond Grade
47NWH	STRIPING, ROOF HATCH, REAR {3M} Decal, Perimeter, 1" Yellow Fluorescent Diamond Grade
47NWJ	STRIPING, SEATLINE {3M} 2" Yellow Fluorescent Diamond Grade
47MTY	WIRING DIAGRAM Schematic, Electrical
	<u>Includes</u> : ACCESS PANEL for Wiring Diagram Schematic Located on Body Exterior; Below Driver Window
47SBB	SUB FLOOR, PLYWOOD Conventional; B-B Marine Grade, Less Sealed Edges, 5/8", 5 Ply, for 31'2", 31'11", 32'8", 33'5", 34'2", 34'11", Body Length
47BDA	FLOOR, COATING , Chemguard Metal Coating, Applied to Main Floor and Intermediate Sills

Vehicle Specifications
2022 INTEGRATED CE S BUS (PB105)

December 01, 2020

Code	Description
47KDC	MONITOR, POST TRIP INSPECTION {Leave No Student Behind} Accessory Controlled, with Push Button Alarm Disable at Rear of Bus Prompts Driver to Walk to Back of Bus and Push Button in Light Bar to Deactivate System
47DNN	SWITCH, LOCATION Left of Driver; Includes Master Flasher, Amber Flasher, and 2 Position Door Control

BODY FEATURES

48ANT	WINDOW, DRIVER Laminated, Clear
48ANM	WINDOW, ENTRANCE DOOR, BOTTOM Laminated, Clear
48ANE	WINDOW, ENTRANCE DOOR, TOP Laminated, Clear
48BJL	COLOR, WINDOW FRAME, PASS (26) Passenger Window, Black
48BAH	WINDOW, E/E, LEFT (2) Vertical Hinge
48BKP	WINDOW, E/E, RIGHT (2) Vertical Hinge
48AUN	WINDOW, PASSENGER, TINT Conventional; 28% Light, Laminated Glass, 78" Headroom, with 31'2", 31'11", 32'8", 33'5", 34'2", 34'11" Body Length
48ARU	WINDOW, SASH (20) 27" Sections, 9"x 23" Opening
48ASP	WINDOW, SASH +9 SECTIONS (2) 9" x 32 1/4" Opening
48APL	WINDOW, STOPS 12" Opening, Only with 78" Headroom
48PAM	WINDSHIELD 3 Flat Pieces, 73% Light, with Band
48PAY	AISLE POSITION Center, for balanced seating
48PBB	FLOOR COVERING, COLOR Black
48PUP	FLOOR COVERING, TRIM Omit
48UWV	FLOOR COVERING, TYPE Koroseal, One Piece, Vinyl, All Body Lengths, Black
48VVR	STEP TREADS {Koroseal} Pebble White Nosing Only, with Non-Metal Backing, used with Formed Treaded Steps
48PAV	WHEEL POCKET COVER Plastic, ABS
48PKC	HOSE CLAMPS, HEATER HOSE Constant Torque for Heater System
48PKR	FAN, DEFOG LEFT CENTER 6.50" Diameter, Black, Mounted Left of Center Post, 2-Speed Switch in Panel
48PPM	HEATER CUT OFF, VALVE Ball, with Butterfly Handle
48PPP	HEATER CUT OFF, VALVE INSIDE Brass Ball, Inside Driver Area
48GYV	HEATER, DEFLECTOR Kit, for Driver Heater
48GHC	HEATER, DRIVER 90,000 BTU, with Defroster and without Rear Heat Duct
	<u>Includes</u>
	: AIR FILTER
	: HEATER HOSES Premium
	: HOSE CLAMPS, HEATER HOSE Mubea Constant Tension Clamps
48PMJ	HEATER, PASS, LT REAR 84,500 BTU
	<u>Includes</u>
	: AIR FILTER
48PNW	HEATER, WATER PUMP {2 MPU 12} Self Priming, with Plastic Housing

Vehicle Specifications
2022 INTEGRATED CE S BUS (PB105)

December 01, 2020

<u>Code</u>	<u>Description</u>
48PZP	ROOF HATCH, FRONT {Specialty 9245-0200} Emergency Exit with Alarm
48PZR	ROOF HATCH, REAR {Specialty 9245-0200} Emergency Exit with Alarm
48PPS	ROOF VENT, FRONT Static
48PPC	SWITCH, HTR FAN, REAR, LT with 84,500 BTU Rear Heater Only
48PTT	ARM REST, DRIVER, RIGHT {National}
48NAT	FITTINGS, AIR SEAT for Driver Seat
48VUK	SEAT, DRIVER {National ABTS 2000} Air Suspension Dual Shock, High Back with Integral Headrest, Isolated, with 2 Position Front Cushion Adjustment, 6 to 17 Degree Seat Back Adjustment, Adjustable Lumbar Support, Includes Additional Padding, 3 Point Lap and Shoulder Belts
	<u>Includes</u> : SEAT BELT, DRIVER Adjustable D-Loop Seat Belt, Single Locking Retractor
48PXP	UPHOLSTERY, BARRIER, TYPE (1-2) Prevaill, 42 oz.
48PVK	UPHOLSTERY, DRIVER SEAT, COLOR Drivers Seat, Brown
48PVA	UPHOLSTERY, DRIVER SEAT, STYLE Plain, with Cloth Insert
48PWR	UPHOLSTERY, DRIVER SEAT, TYPE Prevaill, 42 oz.
48RAE	BARRIER, CRASH, AFT ENTRY DOOR 39", 1 Leg
48RAL	BARRIER, CRASH, AFT DRIVER 39", 1 Leg
48RGR	HAND RAIL, ENTRANCE DOOR, AFT Stainless Steel, 4", Above Step
48RGE	HAND RAIL, ENTRANCE DOOR, FWD Stainless Steel; Curved
48ACN	SEAT BELT, DRIVER, COLOR with Blaze Orange Seat Belt Webbing
48USV	SEAT BACK, PASSENGER High Back
48XGC	SEAT,PASS,3PT,LT,26",2 LEG {BTI Seating System} (01) High Back, with 3 Point Seat Belts
48YAH	SEAT,PASS,3PT,LT,39",2 LEG {BTI Seating System} (12) High Back, with 3 Point Seat Belts
48YAX	SEAT,PASS,3PT,RT,39",2 LEG {BTI Seating System} (13) High Back, with 3 Point Seat Belts
48PWA	UPHOLSTERY, PASS SEATS, COLOR Brown, for Seats, Barriers and Head Bumpers
48PHR	UPHOLSTERY, PASS SEATS, TYPE Prevaill, 42 oz.; for (25-26) Seats
48RLX	CUSHION, SEAT 15" Depth
	<u>Includes</u> : WARRANTY Four Years
48RRA	UPHOLSTERY, SEAT, STITCHING Single
	<u>Includes</u> : WARRANTY Two Years

BODY FEATURES

49MZT	INSULATION, FUEL FILLER Rubber Isolator for Fuel Filler when Exhaust are on Same Side
49AMJ	ALARM, BACKING {Ecco #575} 107 db
49AMT	CIRCUIT, PROTECTION Breakers, Manual Reset in Lieu of Fuses
	<u>Includes</u>

Vehicle Specifications
2022 INTEGRATED CE S BUS (PB105)

December 01, 2020

<u>Code</u>	<u>Description</u>
	: ACCESS PANEL for Body and Chassis Fuses/Circuit Breakers Located on Body Exterior; Below Driver Window
49AJH	CONNECTION, LIGHTS Cluster, Clearance and Side Marker To Tail Lights
49BCN	FLASHER SYSTEM (8) Warning Lights, 8-Lamp System, Electronic Relay Flasher, Non-Sequential Operation, Red Lights Activate with Door Open
49DBR	HOOD, WARNING LAMP (4) Black, 8-Lamp System, One Hood Above Two Lights
49JBU	LIGHT, ENTRY DOOR {Sound Off/OptiLuxx} LED; 4" Oval; Light Mounted in Skirt Behind Entrance Door, Wired To Step Light
49BCR	LIGHT, EXTERIOR, CHECK Automatically Activates Lights for Pre Trip Inspection
49DAG	LIGHT, INDIC, WARNING LIGHTS LED Type; Red and Amber
49JBV	LIGHT, LICENSE PLATE {Sound Off/OptiLuxx} LED, with Mounting Gasket
49JBW	LIGHT, STEP {Sound Off/OptiLuxx} 4" Round LED, White, Wired to Clearance Lights, Operated by Entrance Door
49EYH	LIGHT, STROBE LED, Specialty Man. Co. 845-4020-100, Low Profile, Double Flash, 4.50" High
49AHV	LIGHT, STROBE, STOP SIGN, FRT In Lieu Of Flashing Lights Furnished with Stop Sign, Speciality
49AHY	LIGHT, STROBE, STOP SIGN, REAR In Lieu of the two Flashing Lights Furnished with Stop Sign, Speciality
49ZNC	LIGHTS, BACK UP (2) {Sound Off/OptiLuxx} 4" Round, White, LED, with Flange
49NGD	LIGHTS, BACK UP, ADDITIONAL (2) {Sound Off/OptiLuxx} 4" Oval LED Mounted on Left and Right Skirts, Aft of Rear Wheel Pocket Area, Below Seat Line Rub Rail, Illumination at Rear Tire, Wired to Reverse Light Signal
49JBS	LIGHTS, CLUSTER {Sound Off/OptiLuxx} Oval, 4 Internal LEDs per Light; Amber Front and Red Rear
49BYY	LIGHTS, DIRECTIONAL, FRONT {Sound Off/OptiLuxx} with Park, 7" Round Amber LED, on Front Cowl
49BYZ	LIGHTS, DIRECTIONAL, REAR (2) {Sound Off/OptiLuxx} LED, 7" Round Amber
49EAX	LIGHTS, DIRECTIONAL, SIDE (4) {Sound Off/OptiLuxx} Rectangular LED Armored, 2 Each Side First Section Aft Entrance Door & Forward Rear Wheel Pocket
49JBP	LIGHTS, DOME {Sound Off/OptiLuxx} (07) LED, Rectangular Recessed Type, Mounted in Light Bar
49ESC	LIGHTS, DOME, DRIVER {Sound Off/OptiLuxx} (1) LED, Rectangular, Mounted in Light Bar in Ceiling, with Separate Switch
49BYV	LIGHTS, MARKER, FRONT & REAR (8) {Sound Off/OptiLuxx} LED, Rectangular, Armored, (4) Amber Front and (4) Red Rear
49EAW	LIGHTS, MARKER, SIDE, INTERMED {Sound Off/OptiLuxx} LED, Amber, Rectangular, Armored, Intermediate, Centered, Required for Units 30 Foot or Longer
49BYT	LIGHTS, STOP (2) {Sound Off/OptiLuxx} and Tail; 7" Round LED, Red
49ZNG	LIGHTS, STOP & TAIL ADDITIONAL (2) {Sound Off/OptiLuxx} 4" Round LED, Red, with Flange
49NGJ	LIGHTS, WARNING (8) {Sound Off/OptiLuxx} (4) 7" Round Red Strobing LED and (4) 7" Round Amber Strobing LED, 2 Front, 2 Rear Each Color
49BDL	MONITOR, LIGHT SYSTEM {Sound Off/OptiLuxx} with 16 LED or Incandescent Indicator Lights
49BZU	RADIO, ENTERTAINMENT {Custom Radio} AM/FM Stereo/USB Input, Includes Antenna and Cable, with Public Address System
49ANU	SOURCE, POWER 12 VDC, Mounted In Dash
49AWU	SPEAKERS AND WIRING (6) Flush Mounted in Light Bar

Vehicle Specifications
2022 INTEGRATED CE S BUS (PB105)

December 01, 2020

<u>Code</u>	<u>Description</u>
49ELC	STOP ARM, FRONT Electric, Composite Blade, 18" Octagon, Double Sided, 1/2" White Border, Hi Intensity Grade, Strobing LED Lights
49ELG	STOP ARM, LEFT REAR Electric, Composite Blade, 18" Octagon, Single Sided, 1/2" White Border, Hi Intensity Grade, Strobing LED Lights
49AMD	SWITCH, DRIVER PANEL, TYPE Rocker
49SAA	SWITCH, INSTRUMENT PANEL LIGHTS; Rheostat
49ANH	SWITCH, MAGNETIC, DISCONNECT Master, Ignition Operated, All Body Circuits
49EVL	SWITCH, NOISE SUPPRESSION Actuator Legend States, "NOISE SUPP ", for Separate Solenoid, with Red Switch in Panel
49AMY	SWITCH, REAR DOOR BUZZER for Emergency Door
49BLL	WIRING, VIDEO SYSTEM Power and Ground Connection Only; Connection in Flasher Plate Area with 20 Amp Fuse Protection
49HJX	MIRROR, BRACE, EXTERIOR Telescoping for Stainless Steel Breakaway Bracket
49BVH	MIRROR, CROSS VIEW, EXTERIOR (2) {Mirror Lite High Definition Busboy} Stainless Steel
49EGB	MIRROR, INSIDE 10" x 30", Clear
49EJS	MIRROR, REAR VIEW, EXTERIOR {Rosco} Stainless Steel, Motorized Head, Heated, Breakaway Bracket, Suspended
49ENK	VISOR, INTERIOR, LEFT FRONT 6" x 30", Transparent, For Left Windshield
49GDS	COMPARTMENT ABOVE DRIVER Left of the Driver <u>Includes</u> : COMPARTMENT ABOVE DRIVER Compartment Size: 39" x 10" x 10" : HINGES Piano Type
49GGE	FIRE EXTINGUISHER, DRIVER AREA 5 lb 2A-40BC Minimum with Flexible Hose and Metal Nozzle
49GAY	KIT, BODY FLUID Texas
49EBA	KIT, FIRST AID Plastic; 24 Unit, Spec State
49MZV	LATCH, COMPARTMENT Locking, for Overhead Storage Compartment
49GDG	PADDING COMPART ABOVE DRIVER Window; Safety Equipment Compartment, with Cutout for Dome Light
49GLP	REFLECTORS, REAR (2) 3", Red, Mounted with Screws
49GLM	REFLECTORS, SIDE, FRONT (2) 3", Amber; 1 Aft Drivers Window Left, 1 Aft Entrance Door Right, Mounted with Screws
49GLA	REFLECTORS, SIDE, INTERMEDIATE (2) 3" Amber, 1 Each Side, Mounted with Screws, Below The Third Rub Rail From the Top
49GLG	REFLECTORS, SIDE, REAR (2) 3", Red, Mounted with Screws
49GEP	SAFETY TRIANGLES Warning Reflectors, Ship Loose
49GUB	CUTTER, SEAT BELT {TIE TECH Safecut} for Cutting Seat Belts
49GCC	CUTTER, SEAT BELT, LOCATION Centered on Inside of Driver Compartment Lid
49JAC	DEF FILLER DOOR with Non-Locking Latch
49GUK	FENDERS, RUBBER, REAR (2)
49MZS	FUEL FILLER DOOR Non-Locking, Lever Latch, Spring Loaded to Hold in Open Position

Vehicle Specifications
2022 INTEGRATED CE S BUS (PB105)

December 01, 2020

Code	Description
49CKS	FUEL FILLER PIPE Low Profile Neck Cap and Vent Hosing, for Use with Left Side Fill for Between the Rail Fuel Tanks, for Above the Floor Fuel Fill, for 25 GPM Fill Rate Only
49GUM	INSPECTION PLATE Fuel Sending Unit 8" x 8" Steel
49GVA	MUD FLAPS, FRONT WHEELS (2) Anti-Sail and Anti-Spray
49GUY	MUD FLAPS, REAR WHEELS (2) Anti-Spray, Anti-Sail
49GWW	WINDSHIELD WASHER Kit; 6 Quart Capacity, Bottle
	<u>Includes</u> : WINDSHIELD WASHER ELECTRICAL CONNECTIONS Sealed and Locking Type
49GBV	WINDSHIELD WIPERS (2) Cowl Mounted
	<u>Includes</u> : WINDSHIELD WIPERS CONTROL Single Motor, Overlapping Wipe Pattern
49UBZ	STATE OF OPERATION Texas

Services Section:

WARRANTY

40126	WARRANTY Standard for CE, RE, BE School Bus Models, Effective with Vehicles Built March 1, 2017 or Later, CTS-3304H
40RAP	SERVICES, TOWING {Navistar} Service Call to 24-Month/Unlimited Mileage to the Nearest IC Bus Dealer for Navistar Warrantable Failure as Contract Defined; Includes Engine Failure if Supplier Declines Tow Coverage & ESC Supplied thru Navistar; \$1100 (USA) Maximum Benefit per Incident
40PLG	SRV CONTRACT, EXT VEH COVERAGE {Navistar} To 60-Month/100,000 Miles (160,000 km), Covers 100% Parts and Labor; Includes Body; Excludes Extending Warranty for Engine, Transmission, Perforation or Corrosion of Cab/Cowl Structure and Paint

BODY FEATURES

49GVN	WARRANTY 5-Year, Limited
	DOT INSPECTION - Set Govern speed @ 65mph
	PRE DELIVERY INSPECTION - Pro Air
	WEIGHT SLIP
	3PT SEAT INCENTIVE
	Defrost Kit, Pro Air
	Bus Air 136K BTU Air Conditioning PRO AIR
	6 Camera Safety Vision installed LHB, #E180005958
	ROSCO SAFE-T-SCOPE 360 CAMERA SYSTEM WITH 7" MOR-VISION ULTRA BRIGHT MONITOR IN 10"X30" MIRROR. 4 CAMERAS: FRONT,REAR,TWO SIDES. INSTALLED AT IC PLANT TULSA.
	ADDITIONAL SPA INVOICE CREDIT

Financial Summary
2022 INTEGRATED CE S BUS (PB105)

December 01, 2020

<u>Description</u>	(US DOLLAR)	<u>Price</u>
Net Sales Price:		\$469,176.00

Please feel free to contact me regarding these specifications should your interests or needs change. I am confident you will be pleased with the quality and service of an IC Corporation vehicle.

PRICE PER VEHICLE: \$117,294.00

FOUR (4) VEHICLES: \$469,176.00

BUY BOARD FEE: \$800.00

PRICE DOES NOT INCLUDE BUY BOARD FEE \$800 PER PURCHASE ORDER, PLEASE ADD IF APPLICABLE. BUY BOARD CONTRACT #630-20

Approved by Seller:

Accepted by Purchaser:

Official Title and Date

Firm or Business Name

Authorized Signature

Authorized Signature and Date

This proposal is not binding upon the seller without Seller's Authorized Signature

Official Title and Date

The TOPS FET calculation is an estimate for reference purposes only. The seller or retailer is responsible for calculating and reporting/paying appropriate FET to the IRS.

The limited warranties applicable to the vehicles described herein are Navistar, Inc.'s standard printed warranties which are incorporated herein by reference and to which you have been provided a copy and hereby agree to their terms and conditions.

Action Sheet

MEETING DATE: December 16, 2020

AGENDA ITEM: Discuss and consider approval of \$25,000 Change Order Decrease to CFI Mechanical's contract for the District-Wide MEP Renovation Project

In 2019, the Board approved a \$1,063,759 contract with CFI Mechanical for district-wide MEP renovations. The project is now complete and there is a \$25,000 deductive change order for unused Owner's Contingency that will reduce the final contract amount to \$1,038,759.

RECOMMENDATION: I move that the board approve the \$25,000 change order decrease to CFI Mechanical's contract for the district-wide MEP renovation project, as presented.

Kelli Moulton
Superintendent

Connie Morgenroth
Assistant Superintendent of Business & Operations



AIA Document G701™ – 2017

Change Order

PROJECT: (Name and address)
District-Wide MEP Renovations
CFI Mechanical Package
LEAF Project No. 18232.04

CONTRACT INFORMATION:
Contract For: Construction
Date: June 25, 2019

CHANGE ORDER INFORMATION:
Change Order Number: 01
Date: September 2, 2020

OWNER: (Name and address)
Galveston Independent School District
3904 Avenue T
Galveston, Texas 77550

ARCHITECT: (Name and address)
LEAF Engineers
11 Greenway Plaza, 22nd Floor
Houston, Texas 77046

CONTRACTOR: (Name and address)
CFI Mechanical
6109 Brittmore
Hosuton, Texas 77041

THE CONTRACT IS CHANGED AS FOLLOWS:

(Insert a detailed description of the change and, if applicable, attach or reference specific exhibits. Also include agreed upon adjustments attributable to executed Construction Change Directives.)

Credit unused Owner's Contingency in the amount of \$25,000.00 back to Original Contract Sum

The original Contract Sum was	\$	1,063,759.00
The net change by previously authorized Change Orders	\$	0.00
The Contract Sum prior to this Change Order was	\$	1,063,759.00
The Contract Sum will be decreased by this Change Order in the amount of	\$	25,000.00
The new Contract Sum including this Change Order will be	\$	1,038,759.00

The Contract Time will be increased by Zero (0) days.
The new date of Substantial Completion will be N/A

NOTE: This Change Order does not include adjustments to the Contract Sum or Guaranteed Maximum Price, or the Contract Time, that have been authorized by Construction Change Directive until the cost and time have been agreed upon by both the Owner and Contractor, in which case a Change Order is executed to supersede the Construction Change Directive.

NOT VALID UNTIL SIGNED BY THE ARCHITECT, CONTRACTOR AND OWNER.

LEAF Engineers

ARCHITECT (Firm name)

SIGNATURE
David Templeman, Project Manager

PRINTED NAME AND TITLE
September 2, 2020

DATE

CFI Mechanical

CONTRACTOR (Firm name)

SIGNATURE
Roy L. Cizmar / Service Director

PRINTED NAME AND TITLE
November 3, 2020 D011008

DATE

Galveston Independent School District

OWNER (Firm name)

SIGNATURE

PRINTED NAME AND TITLE

DATE

Action Sheet

MEETING DATE: December 16, 2020

AGENDA ITEM: Discuss and approve the 2021-2022 School Calendar

The proposed calendar has gone through several iterations with feedback from teachers, administrators, and support staff. The calendar was presented at the DEC meeting on November 16, 2020. It was also presented to the Curriculum Team and the Administrative Team for review. Through the District Education Committee, the calendar was distributed to the campuses and faculty and staff for comment. Based on the feedback received, Administration is recommending the proposed calendar. The calendar also includes three Early Release times for planning and/or professional learning as well as a Fall Parent Teacher Conference date and a Spring Parent Teacher Conference date.

RECOMMENDATION: I move that the board approve the 2021-2022 school calendar.

Kelli Moulton
Superintendent

Annette Scott
Assistant Superintendent for C & I

AUGUST 2021 T= 18 S= 7

S	M	T	W	T	F	S
1	2	3	4	5	6	7
8	9	10	11	12	13	14
15	16	17	18	19	20	21
22	{S	24	25	26	27	28
29	30	31				

SEPTEMBER 2021 T= 21 S= 21

S	M	T	W	T	F	S
			1	2	3	4
5	H	7	8	9	10	11
12	13	14	15	16	17	18
19	20	21	22	23	24	25
26	27	28	29	30		

OCTOBER 2021 T= 21 S= 20

S	M	T	W	T	F	S
					1	2
3	[4	5	6	7	8	9
10	TC	12	13	14	15	16
17	{18	19	20	21	22	23
24	25	26	ER	28	29	30
31						

NOVEMBER 2021 T= 17 S= 17

S	M	T	W	T	F	S
	1	2	3	4	5	6
7	[8	9	10	11	12	13
14	15	16	17	18	19	20
21	H	H	H	H	H	27
28	29	30				

DECEMBER 2021 T=13 S=13

S	M	T	W	T	F	S
			1	2	3	4
5	6	T	8	T	T	11
12	13	14	15	16	17	18
19	20	21	22	23	24	25
26	27	28	29	30	31	

JANUARY 2022 T=20 S=19

S	M	T	W	T	F	S
						1
2	{[W	4	5	6	7	8
9	10	11	12	13	14	15
16	H	18	19	20	21	22
23	24	25	26	27	28	29
30	31					

GALVESTON ISD- Draft 21/22

KEY:

- [] = Six Weeks
- { } = Nine Weeks
- NT = New Teacher Days
- ET = Experienced Teachers Return
- S = School Starts
- T = Testing Days
- H = Holidays
- SH = Student Holiday
- W = Teacher Prep
- ER = Early Release
- I = In-Service/Staff Development
- G = Graduation
- TC = Teacher/Parent Conference Day
- TP = Teacher Planning

Student Days - 173

1st Sem. 8/23/21 – 12/17/21

Total Days = 78

2nd Sem. 1/4/22 – 5/26/22

Total Days =95

High School = 6 Weeks

1st Six Weeks (29 days) 8/23 – 10/1

2nd Six Weeks (24 days) 10/4 – 11/5

3rd Six Weeks (25 days) 11/8 – 12/17

4th Six Weeks (28 days) 1/3 – 2/11

5th Six Weeks (34 days) 2/14 – 4/8

6th Six Weeks (33 days) 4/4 – 5/26

Elementary & Middle Schools = 9 weeks

1st Nine Weeks (38 days) 8/23 – 10/15

2nd Nine Weeks (40 days) 10/18 – 12/17

3rd Nine Weeks (47 days) 1/3 – 3/11

4th Nine Weeks (48 days) 3/28 – 5/26

Teacher Days = 187

New Teacher In-Service

August 2-6, 2021(5 days)

All Teachers

August 9 –20, 2021(10 days)

Staff Dev/In-Service/Work/Planning

- October 11, 2021 (TC)
- January 3, 2022 (W)
- February 21, 2022 (TC)
- May 27, 2022 (W)

Early Release & Early Release/Work Days

- October 27, 2021
- March 30, 2022
- May 26, 2022

End of First Semester

- December 17, 2021

Graduation – May 26, 2022

FEBRUARY 2022 T= 20 S=19

S	M	T	W	T	F	S
		1	2	3	4	5
6	7	8	9	10	11	12
13	[14	15	16	17	18	19
20	TC	22	23	24	25	26
27	28					

MARCH 2022 T= 18 S=18

S	M	T	W	T	F	S
		1	2	3	4	5
6	7	8	9	10	11	12
13	14	15	16	17	18	19
20	{21	22	23	24	25	26
27	28	29	ER	31		

APRIL 2022 T= 20 S= 20

S	M	T	W	T	F	S
					1	2
3	4	T	T	T	T	9
10	[11	12	13	14	H	16
17	18	19	20	21	22	23
24	25	26	27	28	29	30

MAY 2022 T= 20 S= 19

S	M	T	W	T	F	S
1	2	T	T	T	T	7
8	9	T	T	T	T	1
15	16	17	18	19	20	21
22	23	24	25	ER/G	W	28
29	H	31				

JUNE 2022

S	M	T	W	T	F	S
			1	2	3	4
5	6	7	8	9	10	11
12	13	14	15	16	17	18
19	H	T	T	T	T	25
26	27	28	29	30		

JULY 2022

S	M	T	W	T	F	S
					1	2
3	H	5	6	7	8	9
10	11	12	13	14	15	16
17	18	19	20	21	22	23
24	25	26	27	28	29	30
31						

Action Sheet

MEETING DATE:

December 16, 2020

AGENDA ITEM:

Discuss and consider elimination of any admissions process for GISD schools that utilizes a matrix to sort and rank students.

The GISD Board Curriculum Committee Chair has requested consideration to change the process for admissions at Austin Middle School, and subsequently all schools in GISD.

Currently, as a subset of the Schools of Choice process, 4th grade students may make application to Austin Middle School and are ranked for admission based on academic grades, STAAR scores, nationally normed assessment scores, conduct and attendance. The top-ranked 150 students are invited to attend AMS.

Discussion in the committee indicates affirmation or elimination of this practice effective 2021.

RECOMMENDATION:

I move that the GISD board of trustees approve the elimination of an admissions matrix for schools in GISD.

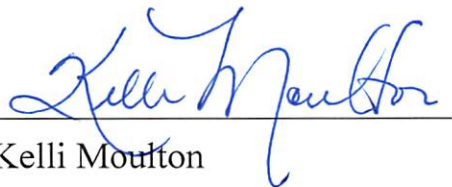

Kelli Moulton

Superintendent

Action Sheet

MEETING DATE:

December 16, 2020

AGENDA ITEM: Discuss and consider reconfiguration of GISD middle schools to establish a single 7/8 grade campus at Central Middle School.

The GISD Board Curriculum Committee Chair has requested consideration to change the current configuration of GISD middle schools from three 5-8 grade schools to one 7-8 grade campus at Central Middle School. Consideration of grade 5-6 will be determined at a later date.

Discussion in the committee indicates a board decision to help staff adequately prepare for the 2021-2022 school year.

RECOMMENDATION:

I move that the GISD board of trustees approve the reconfiguration of Central Middle School to serve all traditional GISD 7-8 grade students.



Kelli Moulton

Superintendent

Action Sheet

MEETING DATE:

December 16, 2020

AGENDA ITEM:

Discuss and consider approval of the August 31, 2020 Annual Financial and Compliance Report.

As required by the Texas Education Code and Board Policy CFC Legal, the Board shall have the District's fiscal accounts audited annually. The financial report for the August 31, 2020 fiscal year is ready to be approved.

A representative from Mitchell T. Fontenote, CPA firm will report on the examination conducted on the District's financial operations and answer any questions. The final draft report is attached for your review.

RECOMMENDATION:

I move that the board approve the August 31, 2020 Annual Financial and Compliance report, as presented.



Kelli Moulton
Superintendent



Connie Morgenroth
Assistant Superintendent of Business & Operations

Action Sheet

MEETING DATE:

December 16, 2020

AGENDA ITEM:

Discuss and Name the Lone Finalist for Superintendent of Schools.

RECOMMENDATION:

I move that the Board of Trustees select _____ as the Lone Finalist for the Superintendent of Schools.

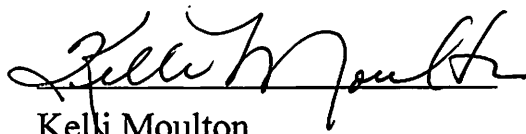

Kelli Moulton
Superintendent