

**WAUNAKEE COMMUNITY SCHOOL DISTRICT
BOARD OF EDUCATION REGULAR MEETING**

Monday, November 10, 2025

6:30 PM

Waunakee Community School District
905 Bethel Circle
Waunakee, WI 53597

Members of the public may attend Board of Education meetings in-person. Members of the public who choose to access the meeting via live stream video may do so at:

<https://www.youtube.com/channel/UClgebJT-i0GbAiYqrkpaBmA>

Public comments will be limited to 3 minutes. The Board will allow 30 minutes for public comments.

Public comments may be sent to Rebecca McDonough at district_administrator@waunakee.k12.wi.us up to one hour before the start of the Board meeting. All comments will be reviewed by the Board members. Emailed comments will be reviewed by the board but not read out loud. Emailed comments sent during any part of the board meeting (Board Development, Closed session, Open session) will be forwarded to the board but may not be reviewed by the board until after the board adjourns. Comments must include the commentator's name, address, and must identify their connection to the District (if any) and any group they are representing in order to be considered by the Board.

If you would like to address the Board in-person during the public comments section of the meeting, you will be asked to check in with District personnel when you arrive so that you can be recognized and address the Board when your name is called.

A recording of the meeting will be posted on the District webpage within 24 hours of the meeting time.

Closed Session Starts at 6:30PM

Open Session Starts at 7:00 PM

AGENDA

I. CALL TO ORDER

II. ROLL CALL

III. CLOSED SESSION - ADJOURN TO CLOSED SESSION PER WISCONSIN STATUTES 19.85 (1) (c), (e), (f), and (g).

- A. Review Closed Session Minutes for the October 13, 2025 regular meeting
- B. Update and Consideration of Legal Matters Related to the School District Including Current and Potential Actions Involving the School District.
- C. Review Individual Administrator, Teacher, Co-Curricular, Support Staff & Custodial Recommendations, Resignations, Leaves & Retirements

IV. RETURN TO OPEN SESSION

V. APPROVAL OF MINUTES

- A. Review Open Session Minutes for the October 13, 2025, regular meeting 6
and the October 30, 2025, Special meeting.

VI. APPROVAL OF AGENDA AND ADDITIONS

A motion will be necessary to approve the agenda as presented (or) with changes as recommended.

VII. PUBLIC COMMENTS **12**

Individuals may use this time to comment on any school district related items. A copy of Board Policy 187 —Public Participation at Board Meetings is enclosed for your reference. Past practice has allowed 30 minutes for this section of the agenda.

**VIII. TEACHING STAFF, STUDENT,
& BOARD REPORTS/RECOMMENDATIONS/ACTION ITEMS**

A. Student Reports

1. Student Council Report

Abigail Anderson and Alena Wagoner are the student representatives from the high school and will be present to report to the Board on what is occurring at the high school.

2. Warrior Spotlight

15

A brief update will be shared by the High School Peer Tutors.

B. Teacher's Update

Representatives from the Waunakee Teachers Association will provide an update on some of the work they are doing in the district.

C. Board Reports/Action Items

1. Board Reports on Educational Related Events, Meetings, or Trainings Attended by Individual Board Members

This section is reserved for any comments from members of the Board on meetings they attended or other informational items.

2. Spring Board Election

a. Notice of School Board Election

25

Attached is the Notice of the April 2026 School Board Election. Dawn Heinrichs (Village of Waunakee), and Joan Ensign (Town of Westport, City of Middleton and City of Madison) seats are on the ballot this spring.

b. Notification of Non-Candidacy

26

Attached is the Notification of Non-Candidacy should an incumbent choose not to run for reelection this spring. The deadline for an incumbent to file the non-candidacy form is December 26, 2025 at 5:00 p.m.

3. American Education Week November 17 - 21, 2025

27

Attached for your discussion please find letters from the board of education, drafted by Anne Blackburn and Mark Hetzel. One to be posted in the Waunakee Tribune and one to be sent to the WCSD Staff.

IX. COMMITTEE REPORTS/RECOMMENDATIONS/ACTION ITEMS

A. DEI Committee

29

The minutes from the November 3, 2025 DEI committee will be reviewed.

B. Budget Committee

30

The minutes from the November 7, 2025, budget committee will be reviewed.

1. 4K Options for 2026-2027 school year - Discussion Item

32

The administration is beginning the process to prepare 2026-2027 budget scenarios. The attached document compares a base scenario with multiple scenarios for a 4K program. The base scenario includes the following:

1. A more conservative enrollment projection
2. Utilizing the November 2024 operational referendum funds
3. Increased revenues for high-cost special ed aid and state categorical aid due to the state budget changes
4. Increased revenues for open enrollment students
5. Increased expenses for the classified staff average pay catch up per the approved operational referendum
6. Increased expenses for annual pay increases (3% CPI + 2% compensation systems), utilities (added Middle School), transportation (5%), contingency (added 100K), maintenance (added back in NAMI contract)
7. Added 3 FTE for the use of existing Middle School/New Middle School

Each of the 4K scenarios changes the base scenario and the major financial impacts are described in the charts. Administration reviewed scenarios with the budget committee and received feedback.

The November board meeting will be an opportunity to discuss this topic with all Board members and Administration will be requesting a decision in December to allow communication with the community and 4K centers.

2. Natural Gas Purchasing program — Action Item 35

In addition, the budget committee requested a review of our natural gas purchasing program. Attached please find a review shared by our vendor. Administration will be requesting a recommendation for the December 1, 2025 to April/May 2026 timeframe.

X. ADMINISTRATIVE REPORTS/RECOMMENDATIONS/ACTION ITEMS

A. Summer School

Sheila Weihert, Principal at Arboretum Elementary and Summer School Coordinator, will be present at Monday's Board Meeting to review Summer School 2025 and seek approval for course offerings for Summer School 2026.

1. 2025 Summer School Update - Informational Item 37
2. 2026 Summer School Course Offerings - Action Item 40

B. Administrative Update regarding DEI from the Director of Special Education, Tiffany Loken and the Director of Secondary Curriculum and Instruction, Tim Schell. 41

C. The Directors of Curriculum and Instruction will be available to answer any questions regarding the September Report Card Presentation.

You may find this presentation in the recording of the September 24, 2025, Curriculum committee which is posted in Boardbook. This is only a time to ask questions of the

Curriculum Directors regarding the presentation.	
D. Waunakee High School Planning (Scope) - Action Item	52
The board will take action on the Waunakee High School Planning (Scope).	
E. Announcements	
XI. <u>CONSENT AGENDA</u>	
A. Approval of Checks	
Attached in the "extras" section of BoardBook, please find a list of the accounts payable payments issued during the month of October 2025.	
B. Finance	
1. Monthly Finance Reports	87
Attached you will find the Budget Status report as of October 31, 2025.	
The cash reconciliation report for September and October will be presented at the December board meeting.	
C. Gifts and Field Trips	
1. Gifts	
a. Jeremy & Sarah Alsaker 2007 Chevy Trailblazer valued at \$4,000.	91
b. Ted and Jan Tweed Charitable Fund - \$20,000	92
This donation will provide a scholarship to both High School and Middle School for the next 5 years.	
2. Field Trips	
D. Approve Individual Teacher, Co-curricular, Support Staff & Custodial Recommendations, Resignations, Leaves & Retirements	
XII. <u>BOARD BUSINESS</u>	
A. Legislative Update	
B. Correspondence	
XIII. <u>FUTURE AGENDAS AND MEETINGS</u>	
A. Agenda Items for Next Meeting	
B. Special Meeting	
Curriculum Presentations Nov. 17, 2025 @ 4pm @ Arboretum	
C. Budget Committee	
D. Co-Curricular Committee - Dec. 2, 2025 @ 7:30am	
E. Curriculum Committee — Nov. 24, 2025 @ 4:00pm	
F. Facility Committee	
G. Human Resources Committee	
H. Policy Committee	
I. DEI Committee	
XIV. <u>RETURN TO CLOSED SESSION</u> - (if necessary) to complete agenda as listed under agenda item III	
XV. <u>RETURN TO OPEN SESSION</u>	

XVI. ACTION AS APPROPRIATE, ON ITEMS DISCUSSED IN CLOSED SESSION

XVII. ADJOURN

“Any person who has a qualifying disability as defined by the Americans with Disabilities Act who requires assistance with access or materials should contact the Waunakee Community School District Office at 849-2000, 905 Bethel Circle Drive Waunakee, WI 53597, at least twenty-four hours prior to the commencement of the meeting so that necessary arrangements can be made to accommodate the request.”

Minutes of Regular Meeting - Open

The Board of Education Waunakee Community School District

A Regular Meeting of the Board of Education of Waunakee Community School District was held Monday, October 13, 2025, beginning at 6:00 PM in the Waunakee Community School District, 905 Bethel Circle, Waunakee, WI 53597.

I. CALL TO ORDER

President Ensign called the meeting to order. A motion was made by Heinrichs, second by Sonne, to adjourn to closed session pursuant to Wisconsin Statutes 19.85 (1)(c), (e), (f) and (g) to review individual teacher contract recommendations, resignations and retirements, review individual co-curricular contract recommendations, review individual support staff/custodial staff recommendations, resignations, and retirements, and review student requests. Motion carried 7-0 on a roll call vote. Time 5:58pm

II. ROLL CALL

Eaton – Yes, Ensign- Yes, Frey – Yes, Hetzel- Yes, Heinrichs – Yes (virtual), Murray - Yes, Sonne - Yes

III. CLOSED SESSION - ADJOURN TO CLOSED SESSION PER WISCONSIN STATUTES 19.85 (1) (c), (e).(f) and (g).

- A. Review Minutes of September 8, 2025 Meeting
- B. Update and Consideration of Legal Matters Related to the School District Including Current and Potential Actions Involving the School District.
- C. Review Individual Administrator, Teacher, Co-Curricular, Support Staff & Custodial Recommendations, Resignations, Leaves & Retirements

IV. RETURN TO OPEN SESSION

A motion was made by Frey, second by Heinrichs, to adjourn closed session and reconvene in open session. Motion carried 7-0. Time: 6:17pm

V. BOARD DEVELOPMENT WORKSHOP

- A. *Great on Their Behalf* by AJ Crabill book study
The board reviewed chapters 8, 9, & 10 of the book.

Ensign reconvened in open session at 7:01 by welcoming all in attendance.

VI. APPROVAL OF MINUTES

- A. A motion was made by Heinrichs, second by Hetzel, to approve the minutes as posted.
Motion carried 7-0.

VII. APPROVAL OF AGENDA AND ADDITIONS

A motion was made by Eaton, second by Frey, to approve the agenda as posted with the modification of having the Teacher representatives report before the student representatives. This change is so the teachers may be available for parent/teacher conferences that are being

held during this time. Motion carried 7-0.

VIII. PUBLIC COMMENTS

There were no public comments for this meeting.

IX. TEACHING STAFF, STUDENT, & BOARD REPORTS/RECOMMENDATIONS/ACTION ITEMS

A. Student Reports

1. Student Council Report

Abigail Anderson and Alena Wagoner are the student representatives presented updates from the High School. They gave updates on the fall sports season, Halloween in the Halls organized by the National Honor Society, FFA, DECA/FBLA Homecoming and all the activities, upcoming student trips, and One Act performances.

2. Warrior Spotlight

A brief update was shared by the Future Educator's Club and Best Buddies.

B. Teacher/Staff Report

1. Staff Report

Marta Rocco, Autumn Pedersen, and Ellen Willrett from the WTA provided a teacher update to the board. They are celebrating all the school building's participation in Hispanic Heritage Month, the flexibility given for parent teacher conferences, the elementary schools fun runs, the dress up days at the Intermediate school and the freshmen homecoming dinner. They expressed gratitude for Kurt Eley subbing at Heritage, discussions to make transportation smoother, and Professional Development around AI.

C. Board Reports/Action Items

1. Board Reports on Educational Related Events, Meetings, or Trainings Attended by Individual Board Members

Several board members along with Dr. Brown and Mr. Schell attended the WASB Region 12 recognition and meeting. WCSD Board members Joan Ensign and Dawn Heinrichs were recognized for their participation in WASB activities.

Several board members joined Representative Joers' visit to Waunakee High School to meet with the Best Buddies program. A special thank you to Heather Murray for arranging this meeting.

2. Board Action on Board Coaching by Ted Neitzke, CESA 6.

After much discussion, a motion was made by Heinrichs, second by Eaton, to approve moving forward with the board coaching process through CESA 6, but to look for dates starting in September 2026. Motion carried 7-0.

3. Board Action on District Administrator Performance Evaluation (DAPES)

A motion was made by Sonne, second by Hetzel, to adopt this evaluation tool for use during the 2026-2027 school year. Motion carried 7-0.

X. COMMITTEE REPORTS/RECOMMENDATIONS/ACTION ITEMS

A. Curriculum Committee

The minutes of the September 24, 2025 curriculum committee was reviewed. Board members on this committee encouraged that their presentation shared be watched by all interested. It is a very good snapshot of where we are at right now.

B. Facility Committee October 6, 2025

The minutes from the October 06, 2025 facility committee meeting were reviewed.

1. Approval of Capital Maintenance Requests

Summers presented and answered questions regarding the review of the district-wide capital maintenance requests. Summers and Cramer shared additional information on the robotic mowers and the basketball hoop technology. A motion was made by Frey, second by Hetzel, to approve the capital maintenance requests as presented. Motion carried 7-0.

C. Budget Committee Meeting

The minutes of the October 6, 2025 budget committee meeting were reviewed.

1. 2025-26 Tax Levy Options

Summers presented and answered questions regarding the review of tax levy options for the 2025-26 school year.

XI. **ADMINISTRATIVE REPORTS/RECOMMENDATIONS/ACTION ITEMS**

A. Third Friday Count

Summers presented and answered questions regarding the 3rd Friday in September report.

B. Administrative Recommendations for Consideration from the Board Workshops in February, March, & August, 2025

1. Branding

Dr. Brown introduced this topic and reviewed the history. A board member asked that this be brought back for consideration. Dr. Brown asked that all board members share their thoughts on this topic. After much discussion, a motion was made by Hetzel, second by Ensign, to fully implement and use BOE approved branding guidelines districtwide with all our programs and activities, including staff representing the district on company time appropriately noted in the revised handbooks, with the exception of personal attire, unless the personal attire shows Native American imagery, beginning January 1, 2026. Motion failed 2-5 on a roll call vote.

ROLL CALL

Eaton – No, Ensign- Yes, Frey – No, Heinrichs – No, Hetzel- Yes, Murray - No, Sonne – No

A motion was made by Heinrichs, second by Eaton, to fully implement and use BOE approved branding guidelines districtwide with all our programs and activities, including staff representing the district on company time appropriately noted in the revised handbooks beginning January 1, 2026. Motion failed 3-4 on a roll call vote.

ROLL CALL

Eaton – Yes, Ensign- No, Frey – No, Heinrichs - Yes, Hetzel – No, Murray - Yes, Sonne – No

Dr. Brown instructed that at this time we will remain as we are regarding this topic.

C. Administrative Update from the Information Technology Director

Technology Director, Rick Franz, presented and answered questions regarding a presentation on the district technology department.

D. Announcements/Correspondence

1. WASB WI State Education Convention, January 21-23, 2026

The registration and hotel blocks will open on November 3, 2025. In order to book rooms, the registration process has to be started. Please let Rebecca know no later than October 24th if you are planning on attending the convention this year. For your convenience, attached please find the convention registration form.

2. School Funding Informational Sessions will be on November 19th at 9am and 6pm

XII. **CONSENT AGENDA**

The Board acknowledged the generous gifts from the Lake Melvin Yacht Club of \$3,000 and The Meffert Oil Co. for the Pride Pump campaign for \$1,000.

A motion was made by Heinrichs, second by Frey, to approve the consent agenda in full as presented. Motion carried 7-0.

- A. Approval of Checks
- B. Finance
 - 1. Monthly Finance Reports
- C. Consideration of School Safety Drills
- D. Gifts and Field Trips
 - 1. Gifts
 - a. Lake Melvin Yacht Club - \$3,000.00 to WCSD Food Service Program.
 - b. Meffert Oil Pride Pump Campaign - \$1,000.00
 - 2. Field Trips
 - a. Consideration of the MS Washington DC trip in 2027
 - b. Consideration of Music and Drama trip to Chicago, Il. on February 12, 2026
 - c. Consideration of 2025 National FFA Convention October 29-November 1, 2025 - Indianapolis, IN
 - d. Consideration of MSAN students attending National Conference in Virginia - November 12-15, 2025
- E. Approve Individual Teacher, Co-curricular, Support Staff & Custodial Recommendations, Resignations, Leaves & Retirements
 - New Teaching Staff**
Kali Rickey, Cross Categorical Special Education Teacher, PES
 - New Support Staff**
Krystle Barman, Para Educator Special Education, AES
Jimmy Chaney, Crossing Guard
Sarah Kraegel, Para Educator Special Education, PES
Laurie Mercurio, Para Educator Special Education, HES
Laura Milbrath, Para Educator Special Education, HS
 - Resignations**
Dominic Harris, Crossing Guard
Bobbi Hartley, Para Educator Special Education, HS
 - Retirements**
Tom Grunder, CD Teacher, HS

The Co-Curricular staff updates is posted on the extras section of the agenda.

XIII. BOARD BUSINESS

- A. Board Correspondence

XIV. FUTURE AGENDAS AND MEETINGS

- A. Agenda Items for Next Meeting
- B. Special Meeting - Setting the Tax Levy Meeting.
October 30, 2025 @ 5:30pm
Additional Agenda items.
- C. Budget Committee - November 7, 2025 @ 8:00am

- D. Co-Curricular Committee
- E. Curriculum Committee
- F. Facility Committee
- G. Human Resources Committee
- H. Policy Committee
- I. DEI Committee - November 3, 2025 @ 5:30pm
- XV. **RETURN TO CLOSED SESSION** – N/A
- XVI. **RETURN TO OPEN SESSION** - N/A
- XVII. **ACTION AS APPROPRIATE, ON ITEMS DISCUSSED IN CLOSED SESSION** – N/A
- XVIII. **ADJOURN**

The Board of Education adjourned at 8:37PM on a motion by Murray, second by Heinrichs, and passed unanimously by voice vote 7-0.

Respectfully submitted,

Carlena Eaton, Clerk

Date: _____
CE/rm

Minutes of Tax Levy Meeting

The Board of Education Waunakee Community School District

A Tax Levy Meeting of the Board of Education of Waunakee Community School District was held Thursday, October 30, 2025, beginning at 5:30 PM in the Waunakee Community School District, 905 Bethel Circle, Waunakee, WI 53597.

I. CALL TO ORDER

President Ensign called the meeting to order at 5:30pm.

II. ROLL CALL

Present: Eaton, Ensign, Frey, Hetzel, Sonne

Also Present: Brown (Virtually), Summers, Borowski, Lensert, Schell, Robin Savola (EUA), Jay Thomsen (Vogel Bros.)

III. APPROVE AGENDA

A motion was made by Hetzel, second by Frey, to approve the agenda as posted. Motion carried 5-0.

IV. PUBLIC COMMENTS There were no public comments for this meeting.

V. 2025- 2026 BUDGET APPROVAL AND TAX LEVY APPROVAL

Summers presented and answered questions regarding the review of the final steps of the 25-26 budget process, and to request School Board approval of the budget and tax levy. A motion was made by Hetzel, second by Sonne, to approve the budget and tax levy as presented. Motion carried on a roll call vote 5-0.

Roll Call:

Eaton – Yes, Ensign – Yes, Frey – Yes, Hetzel – Yes, Sonne – Yes.

A. Budget Changes

B. Tax Levy Changes and Certification

VI. HIGH SCHOOL PLANNING (SCOPE)

Brown, Summers, Savola (EUA), Thomsen (Vogel) presented and answered questions regarding the High School Planning – Scope. Borowski and Lensert were available to answer questions. Sonne requested information on the athletic complex regarding a team center/weather safety building. Administration will be requesting approval of design services, with bids due in the spring of 2026. The board will be taking action on this topic at the November 10, 2025 regular meeting.

A motion was made by Frey, second by Eaton, to adjourn the meeting at 7:08pm. Motion carried 5-0.

Respectfully submitted,

Carlena Eaton, Clerk

Date: _____
CE/rm

PUBLIC COMMENT PERIODS DURING BOARD MEETINGS

Policy 187

Waunakee Community School District

Page 1 of 3

While the public has the right to attend meetings of the Board of Education that have not been convened in a closed session, individuals or groups generally do not have a right to be included on a Board meeting agenda or a right to enter into the discussions or deliberations of the Board. However, without affecting the Board's discretion to authorize other forms of input or participation during Board meetings from persons who are not Board members, the Board expressly authorizes and directs limited public participation during duly-noticed public comment periods as follows:

1. The Superintendent and Board President shall ensure that the agenda and public notice of the Board's primary regular business meeting each month includes a period for public comment. During a public comment period noticed under this paragraph, interested persons may briefly address the Board on topics that are reasonably germane to some aspect of the District's policies, practices, programs, or operations, regardless of whether the speaker's topic is otherwise noticed as a specific subject matter of the meeting in question.
2. Subject to any more specific decision or directive of the Board, the Board President has discretion to include a period of public comment on the agenda and public notice of additional Board meetings. In exercising such discretion, the President may specify on the public notice of the meeting that speaker comments during the public comment period will be limited to topics that are sufficiently germane to the noticed subject matter of the meeting.

When a public comment period is expressly included on the public notice of a Board meeting and there is sufficient interest in addressing the Board, the period shall either include at least 10 individual speakers or extend for 30 actual minutes, whichever limitation permits the greater total number of speakers. However, the Board may extend the total duration of a noticed public comment period at any meeting by a majority vote.

The Superintendent, or his/her designee, will implement a viewpoint-neutral speaker registration process that establishes an order for speaking in the event that the interest in appearing before the Board at any meeting may exceed the time that is allocated for the public comment period. Each speaker, upon being recognized by the presiding officer, will state his/her name and identify his/her connection to the District (if any) and to any group they are representing in connection with their remarks.

Each speaker's presentation is normally limited to a maximum of 3 minutes. However, at a meeting the Board may vote to reduce the time limit to no shorter than 2 minutes per speaker in order to accommodate a greater total number of speakers. In addition, at the Board's discretion, a speaker's time may be briefly extended provided that, upon request, a similar extension shall be granted to other speakers at the same meeting. Any individual may speak only once during the public comment period at any meeting.

Speakers generally should not expect an immediate response or reaction to their comments from the Board. Further:

1. If, at applicable meetings, a speaker raises a topic during a public comment period that was not among the publicly-noticed subject matter of the meeting, the extent of any response to

PUBLIC COMMENT PERIODS DURING BOARD MEETINGS

Policy 187

Waunakee Community School District

Page 2 of 3

the speaker and his/her remarks shall be limited in accordance with applicable law.

2. During a public comment period, Board members will not engage in a substantive discussion of or otherwise attempt to materially investigate or reach a Board resolution of either (a) complaints or grievances regarding the conduct of individual staff members or individual students; or (b) attempts to appeal staff or administrative decisions relating to individual District employees or students. A public comment period during a Board meeting is not the preferred or established means of processing such issues or bringing such matters to the Board's attention.
3. If time or other limitations preclude an interested person from addressing the Board at a specific meeting, the person may submit written information to the Board and/or attempt to utilize a public comment period at a future meeting.

Subject to an appeal to the Board that is made by a Board member, the presiding officer of the Board meeting shall have the authority to conduct and maintain proper order in connection with any authorized public comment period, including the authority to (1) recognize speakers; (2) enforce established time limits; (3) interject and request that speakers voluntarily redirect specific complaints, grievances, or attempted appeals to more appropriate District procedures; and (4) terminate the remarks of any individual who does not adhere to established rules and procedures for public participation, who speaks in a threatening or profane manner, whose comments are repetitive of that person's previous comments, or whose conduct is disruptive and impedes the Board's ability to conduct its business in an orderly and timely fashion.

Individuals who are permitted to address the Board during a meeting are responsible for the content of their comments. The forum represented by a public comment period does not exempt a speaker from any liability arising from his/her comments (e.g., for defamation or for any breach of legally-protected confidentiality).

This policy and any rules and/or procedures that may be adopted related to the administration of public comment periods under this policy are not intended to apply to the following:

1. A meeting or any portion of a meeting that constitutes a formal public hearing on a particular topic or issue.
2. Instances where the Board seeks or agrees, by majority vote, to accept input that is relevant to a noticed agenda item from a person who is not a Board member in order to (for example) resolve a formal or informal point of information that arises during the Board's discussion of an agenda item.
3. Meetings of any standing or ad hoc committee that may be established by the Board.

Legal References:

Wisconsin Statutes

- [Section 19.81](#) [state policy on open meetings]
[Section 19.83\(2\)](#) [discussion during period of public comment]

PUBLIC COMMENT PERIODS DURING BOARD MEETINGS

Policy 187

Waunakee Community School District

Page 3 of 3

[Section 19.84\(2\)](#) [public notice of board meetings, including public comment period]
[Section 19.85](#) [exemptions to open meetings]

Cross References:

WASB PRG 187 Sample Policy 4 (with substantial local adaptation)

Adoption/Revision Date(s):

October 1989
March 1994
September 1994
January 2000
February 2002
May 2020



WAUNAKEE

COMMUNITY HIGH SCHOOL

15

Peer Tutoring & Writing Center

Chris Schiemann
WCHS Library Media Specialist

Mission Statement

Our goal as a peer tutoring & writing center is to provide a resource for all students to improve their academic skills and gain confidence in their work.



2024-2025

332

17

in person visits to Peer Tutors



2024-2025

351

18

Online paper submissions



Historical Background

- Developed by Jeannine Ramsey, prior WCHS LMS
- Site visits to Madison College Writing Center
- Interviewed stakeholders
- Instituted the program in 2015-2016
- Juniors and Seniors who were nominated by their teachers the prior spring



Our Approach with Students

- We are *not* experts
- We are *not* teachers
- We *do* model our approach for students
- We *collaborate* with students
- We provide *feedback* and another point of view
- We offer *specific* praise



Benefits for Peer Tutors

- Honing their own reflection skills
- Oral communication development with peers
- Constructive feedback with specific praise and positive feedback suggestions





HOME > ACADEMICS > LIBRARY > PEER TUTORING & WRITING CENTER

Peer Tutoring & Writing Center

Mission Statement

Our goal as a peer tutoring & writing center is to provide a resource for all students to improve their academic skills and gain confidence in their work.

The Waunakee Community High School Peer Tutoring & Writing Center is a student-staffed service for all WCHS students to get feedback on any type of writing and assistance in all subject areas. Peer Tutors are not teachers, nor will they be able to answer every question; they are successful students nominated by their teachers who volunteer to share their methods and approaches to learning with other students.

Three Options for Peer Tutoring Assistance

Stop By During the Day (BEST):



1. Before school
2. During Study Hall
3. Contact Time: zExtension: Peer Tutoring

Make an Appointment



[Click Here to Signup](#)
[Schedule of Who is Available When](#)

Online Paper Submission



[Submit Here](#)
 *Please allow 48 hours for a peer tutor to review it.



Outreach

- Bulletin Board flyers
- Classroom flyers
- Teacher promotion
- Instagram “Meet our Peer Tutors” posts
- Weekly Warrior



A decorative card for a peer tutor. At the top, the words "PEER TUTOR" are written in a large, orange, sans-serif font, arched over a circular portrait of a young woman with long brown hair, smiling. The portrait is framed by three concentric blue circles. To the right of the portrait, the number "23" is displayed. Below the portrait, the word "JUNIOR" is written in white on a dark orange rounded rectangular background. Below that, the name "CLAIRE" is written in a large, bold, black font inside a white rounded rectangular border. At the bottom, the text "Sports: Tennis, Soccer" and "Activities: NHS, FBLA, DECA, Student Council, Class Officer" is listed in a smaller black font. The card features decorative blue starburst graphics and dotted circular patterns in the corners.

PEER TUTOR

23

JUNIOR

CLAIRE

Sports: Tennis, Soccer
Activities: NHS, FBLA, DECA, Student Council,
Class Officer



QUESTIONS

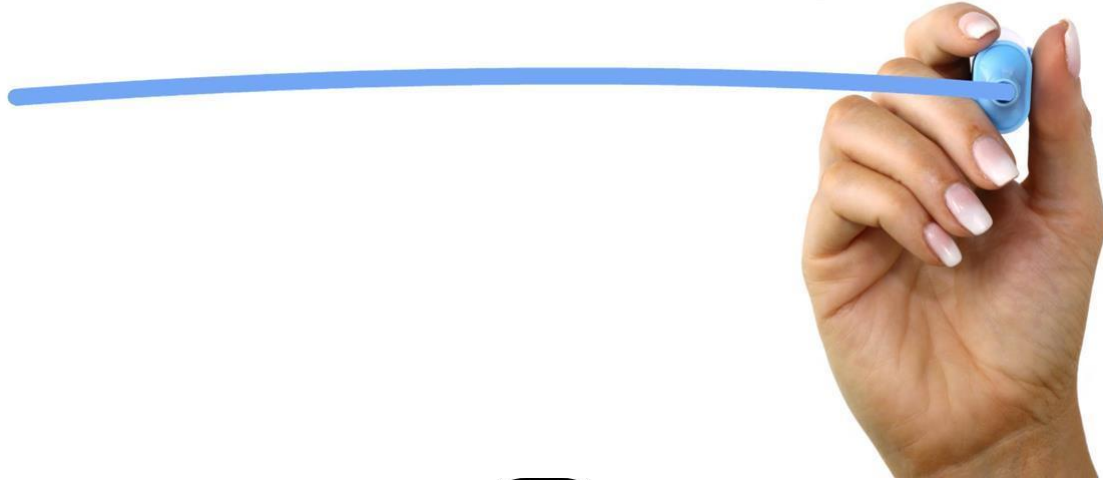

24



NOTICE OF SCHOOL BOARD ELECTION

Waunakee Community School District

April 7, 2026

NOTICE IS HEREBY GIVEN, that at an election to be held in the School District of Waunakee, on Tuesday, April 6, 2026, the following offices are to be elected to succeed the present incumbents listed. The term of offices is three years beginning on Monday, April 27, 2026, expiring on April 23, 2029.

OFFICE

INCUMBENT

School Board Member from the Village of Waunakee

Dawn Heinrichs

School Board Member from the Town of Westport,
Cities of Middleton & Madison

Joan Ensign

NOTICE IS FURTHER GIVEN, that a Campaign Registration Statement and a Declaration of Candidacy, must be filed no later than 5:00 p.m., on Tuesday, January 06, 2026 in the office of the school district clerk. Nomination papers are required, and the first day to circulate nomination papers is December 1, 2025, and the final day for filing nomination papers is 5:00 p.m. on Tuesday, January 06, 2026 in the office of the school district clerk.

NOTICE IS FURTHER GIVEN, that if a primary is necessary, the primary will be held on Tuesday, February 17, 2026.

A description of the school district boundaries can be obtained from the school district office.

Given under my hand,
on November 10, 2025

Carlena Eaton
School District Clerk

FOR OFFICE USE ONLY

NOTIFICATION OF NONCANDIDACY

I, _____, state that I am currently the
(please print name)

incumbent officeholder for the office listed below.

I will not be a candidate for this office at the next election. I understand that the timely receipt* of this notice will avoid an extension of the deadline for filing ballot access documents.

TITLE OF OFFICE: _____
(print current office, including district #, if any)

NEXT ELECTION DATE: _____

SIGNATURE: _____

DATE OF SIGNING: _____

**Notification must be received by the proper filing officer no later than 5:00 p.m. on the 2nd Friday preceding the deadline for filing ballot access documents to avoid an extension of time for filing such papers.*

The information on this form is filed in accordance with §§.8.05(1)(j), 8.10(2)(a), 8.15(1), 8.20(8)(a), 120.06(6)(b), Wis. Stats. This form is prescribed by the Wisconsin Elections Commission, 212 East Washington Avenue, 3rd Floor, P.O. Box 7984, Madison, WI 53707-7984, (608) 266-8005, FAX (608)267-0500, <http://elections.wi.gov> Email: elections@wi.gov.



ADMINISTRATION OFFICE

905 Bethel Circle
Waunakee, Wisconsin 53597
(608) 849-2000

Board of Education

To our Waunakee Community School District staff,

As we mark American Education Week, November 17–21, 2025, please know what you do matters. Public education is a promise we make to every child, and you keep that promise with consistency, skill, and heart.

We value the way you honor what’s worked for generations while adapting to what students need now. Expectations are high, resources are tight, and student needs keep changing. Still, you show up—steady, prepared, and focused on kids.

Thank you to every role that makes learning possible:

- Teachers - designing learning that challenges and supports every student.
- Specialists and Student Services (counselors, psychologists, social workers, nurses, therapists) - attending to student wellness so learning can happen.
- Paraeducators - standing shoulder-to-shoulder with students and teachers to build skills and confidence.
- Administrative Assistants and School Office Teams - keeping families informed and our buildings running smoothly.
- Custodial, Maintenance, and Grounds - safe, clean, reliable spaces that say “you belong here.”
- Food Service (Taher) - nutritious meals that fuel growing minds and bodies.
- Transportation and Crossing Guards - safe, welcoming, calm starts and ends to the school day.
- Information Technology (IT) and Library/Media - reliable tech, resources, and guidance that open doors to knowledge.
- Coaches, Advisors, and Activity Staff - expanding character, leadership, and belonging beyond the bell.
- Administrators - steady leadership, clear expectations, and support for staff and students.

- Substitutes and Volunteers - stepping in so learning doesn't stop.

Because of your exceptional professionalism and unlimited care, students learn, achieve, and grow into the best versions of themselves. That's the outcome, and you make it happen.

On behalf of the Waunakee Community School District Board of Education, thank you for honoring our traditions, for raising the bar, and for never losing sight of why we're here. We're proud of you, and we're with you.

With gratitude,
Waunakee Community School District Board of Education

Joan Ensign, President
Dawn Heinrich, Vice President
Carly Eaton, Clerk
Mark Hetzel, Treasurer
Ted Frey, Director
Heather Murray, Director
Chris Sonne, Director

Minutes of DEI Committee Meeting

The Board of Education Waunakee Community School District

A DEI Committee Meeting of the Board of Education of Waunakee Community School District was held Monday, November 3, 2025, beginning at 5:30 PM in the Waunakee Community School District, 905 Bethel Circle, Waunakee, WI 53597.

I. CALL TO ORDER

Chairperson Murray called the meeting to order at 5:30pm.

II. ROLL CALL

Present: Eaton, Heinrichs, Murray

Also Present: Brown, Loken, Schell

III. APPROVE AGENDA

A motion was made by Heinrichs, second by Eaton to approve the agenda as posted. Motion carried 3-0.

IV. PUBLIC COMMENTS There were no public comments for this meeting.

V. DEI PLAN INFORMATIONAL UPDATES

Loken presented and answered questions regarding the disproportionality plan progress for 2025-2026 and any future planning or revisions.

VI. EQUAL OPPORTUNITY SCHOOLS INTRODUCTION

Schell, as part of the DEI presentation presented and answered questions regarding Equal Opportunity Schools (EOS). EOS seeks to support public educators to increase student participation in advanced coursework, improve school community belonging, and improve post-secondary outcomes for youth.

VII. FUTURE MEETINGS - NA

VIII. ADJOURN

A motion was made by Eaton, second by Heinrichs, to adjourn the meeting at 6:20pm.

Motion carried 3-0.

Minutes of Budget Committee

The Board of Education Waunakee Community School District

A Budget Committee of the Board of Education of Waunakee Community School District was held Friday, November 7, 2025, beginning at 8:00 AM in the Waunakee Community School District, 905 Bethel Circle, Waunakee, WI 53597.

I. CALL TO ORDER

Chairman Hetzel called the meeting to order at 8:00am.

II. ROLL CALL

Present: Ensign (sub for Heinrichs), Hetzel, Sonne

Also Present: Summers, Moe, Brown (virtually), Newton (virtually)

III. APPROVAL OF AGENDA AND ADDITIONS

A motion was made by Ensign, second by Sonne, to approve the agenda as posted. Motion carried 3-0.

IV. PUBLIC COMMENTS There were no public comments for this meeting.

V. 2025-2026 PLANNING

A. Update

Summers presented and answered questions regarding the update on the process of completing the 2025-2026 budget process. Summers also presented and answered questions regarding an update on the progress and utilization of the McKinney-Vento district provided transportation.

VI. 2026-2027 PLANNING

Summers informed the committee of the process to prepare 2026–2027 budget scenarios regarding 4K. Brown introduced and explained the new state program called the Get Kids Ready Program which begins during the 2026-2027 school year. Summers review the assumptions of the base budget scenario, as well as scenarios with different 4K student counts. After much discussion regarding possible scenarios, the committee was interested to explore the scenario that includes making an 2026-27 4K contact offer to the sites. The Budget Committee also requested administration to evaluate scenarios of what would happen should a percentage of the 4K sites choose not to go with the district.

The committee also asked the administration to look offering varying amounts to the 4K partner sites and also have administration share all the benefits, in addition with the contracted amount to the sites. Administration will continue to prepare scenarios for consideration by the Board.

VII. DISCUSSION/ACTION ON PROPOSALS

Summers presented and answered questions regarding a request from the committee to share more information regarding the savings with Data Wrangler and specifically clarification at the new Heritage site. Summers also gave an update on our natural gas purchasing program and requested a recommendation for the December 1, 2025 to April/May 2026 timeframe.

Sonne made a motion, seconded by Ensign, to recommend that the full board consider locking in our natural gas purchase to 75% of expected use from December 2025 – October 2026. Motion carried 3-0.

VIII. OTHER ITEMS FOR DISCUSSION

Summers shared information about clean energy incentives and the Middle School solar program.

IX. FUTURE AGENDA ITEMS

The committee requested a comparison report the 26-27 budget.

X. ADJOURN

A motion was made by Sonne, second by Ensign to adjourn the meeting at 9:18am. Motion carried 3-0.

Wisconsin 2025–27 State Budget: 4K Program Changes Starting in 2026–27

This document summarizes the changes to Wisconsin’s Four-Year-Old Kindergarten (4K) program as enacted in the 2025–27 state budget (2025 Wisconsin Act 15), with particular focus on provisions that take effect beginning in the 2026–27 school year.

1. Get Kids Ready Program (Starting 2026–27)

- A new community-based elementary school-readiness program administered by the Department of Children and Families (DCF), called Get Kids Ready, begins during the 2026–27 school year.
- Annual funding of \$66 million supports the program.
- Payments go to licensed or certified child-care providers serving four-year-olds.
- Providers must deliver at least 437 hours of instruction annually using a curriculum aligned to the Wisconsin Model Early Learning Standards.
- Teachers must hold at least an associate or bachelor’s degree.
- Providers may not participate in Get Kids Ready if they also contract with a public school district to provide 4K in the same year.

2. FTE Counting and Outreach Requirement Changes

- Beginning with the 2025–26 school year, all 4K public education pupils are counted at 0.60 Full-Time Equivalent (FTE) for membership, revenue limits, and aid computations.
- Outreach hours are no longer required for 4K programs.
- Districts should review their pupil-counting practices and budgeting projections to align with the new rules.

3. Related Early Care and Child-Care Investments

- Child Care Bridge Payments and Wisconsin Shares reimbursement increases are included to stabilize provider capacity.
- These supports reduce parent costs and complement Get Kids Ready by expanding access to early learning options.

4. Practical Implications for Districts

- Some families may choose community providers in Get Kids Ready instead of district 4K; providers cannot participate in both a district 4K contract and Get Kids Ready in the same year.
- The 0.60 FTE rule will directly affect district revenue-limit and aid allocations. Business offices should carefully review enrollment and financial planning in light of these changes.

**Comparison of Base Scenario to various 4K Scenarios
Waunakee Community School District**

Scenario	4K students	Expense	Comments
Base Scenario	245	\$0	no changes
Scenario 1	0	(\$900,000)	No 4k program
Scenario 2	90	(\$600,000)	4K in each building
Scenario 3	168	(\$300,000)	4K in each building, keep half of partners
Scenario 4	245	\$343,000	district increases payment to providers to \$5K
Scenario 5	245	\$300,000	4K in each building, remaining 4K students at MS

Base Scenario	Prior Years		Current 2025-26	Projections				
	2023-24	2024-25		2026-27	2027-28	2028-29	2029-30	2030-31
4K Class Size	238	249	221	245	245	245	245	245
Eq. Valuation Growth		8.3%	9.6%	6.0%	6.0%	6.0%	6.0%	6.0%
Rev. Limit/Member Incr.	325	325	325	325	325	325	325	325
Referendum	\$5,127,502	\$8,127,502	\$9,650,000	\$2,600,000	\$2,100,000	\$0	\$0	\$0
Fund 10 Revenues	\$64,018,308	\$68,102,085	\$71,192,701	\$74,485,842	\$75,890,765	\$77,031,433	\$78,463,403	\$79,774,057
Fund 10 Expenditures	\$64,559,224	\$68,102,085	\$71,192,701	\$74,183,613	\$77,603,206	\$81,261,585	\$85,003,258	\$88,817,559
Surplus (Deficit)	(\$540,916)	\$0	\$0	\$302,229	(\$1,712,441)	(\$4,230,152)	(\$6,539,855)	(\$9,043,502)
Fund Balance	\$7,481,181	\$7,481,181	\$7,481,181	\$7,783,410	\$6,070,968	\$1,840,816	(\$4,699,039)	(\$13,742,541)
Fund Balance %	11.6%	11.0%	10.5%	10.5%	7.8%	2.3%	-5.5%	-15.5%
Operating Expenses	\$68,767,429	\$72,712,783	\$77,491,249	\$82,151,544	\$85,825,095	\$89,750,131	\$93,771,793	\$97,880,083
Equalization Aid	\$24,685,494	\$24,634,807	\$23,334,386	\$22,516,448	\$21,936,235	\$19,693,888	\$17,927,521	\$15,283,928
Total Tax Levy	\$41,692,918	\$44,823,271	\$47,501,003	\$51,319,511	\$53,299,417	\$56,751,237	\$59,998,861	\$63,925,799
Mill Rate	\$8.97	\$8.90	\$8.60	\$8.77	\$8.59	\$8.63	\$8.61	\$8.65

Scenario #1	Prior Years		Current 2025-26	Projections				
	2023-24	2024-25		2026-27	2027-28	2028-29	2029-30	2030-31
4K Class Size	0	0	0	-245	-245	-245	-245	-245
Fund 10 Revenues	\$0	\$0	\$0	(\$36,358)	(\$812,795)	\$782,184	(\$2,183,124)	(\$5,634,521)
Fund 10 Expenditures	\$0	\$0	\$0	(\$900,000)	(\$900,000)	(\$900,000)	(\$900,000)	(\$900,000)
Surplus (Deficit)	\$0	\$0	\$0	\$863,642	\$87,205	\$1,682,184	(\$1,283,124)	(\$4,734,521)
Equalization Aid	\$0	\$0	\$0	\$0	(\$2,797,254)	(\$3,100,972)	(\$3,823,542)	(\$3,295,546)
Total Tax Levy	\$0	\$0	\$0	\$0	\$2,057,175	\$4,126,779	\$2,087,844	(\$1,616,020)
Mill Rate	\$0.00	\$0.00	\$0.00	\$0.00	\$0.33	\$0.63	\$0.30	-\$0.22

Scenario #2	Prior Years		Current 2025-26	Projections				
	2023-24	2024-25		2026-27	2027-28	2028-29	2029-30	2030-31
4K Class Size	0	0	0	-155	-155	-155	-155	-155
Fund 10 Revenues	\$0	\$0	\$0	(\$23,002)	(\$514,221)	\$50,920	(\$1,751,140)	(\$4,023,414)
Fund 10 Expenditures	\$0	\$0	\$0	(\$600,000)	(\$600,000)	(\$600,000)	(\$600,000)	(\$600,000)
Surplus (Deficit)	\$0	\$0	\$0	\$576,998	\$85,779	\$650,920	(\$1,151,140)	(\$3,423,414)
Equalization Aid	\$0	\$0	\$0	\$0	(\$1,761,758)	(\$1,936,171)	(\$2,833,462)	(\$2,453,978)
Total Tax Levy	\$0	\$0	\$0	\$0	\$1,293,541	\$2,141,180	\$1,365,271	(\$1,112,117)
Mill Rate	\$0.00	\$0.00	\$0.00	\$0.00	\$0.21	\$0.33	\$0.20	-\$0.15

Scenario #3	Prior Years		Current 2025-26	Projections				
	2023-24	2024-25		2026-27	2027-28	2028-29	2029-30	2030-31
4K Class Size	0	0	0	-77	-77	-77	-77	-77
Fund 10 Revenues	\$0	\$0	\$0	(\$11,377)	(\$249,327)	(\$541,108)	(\$1,366,299)	(\$2,636,986)
Fund 10 Expenditures	\$0	\$0	\$0	(\$300,000)	(\$300,000)	(\$300,000)	(\$300,000)	(\$300,000)
Surplus (Deficit)	\$0	\$0	\$0	\$288,623	\$50,673	(\$241,108)	(\$1,066,299)	(\$2,336,986)
Equalization Aid	\$0	\$0	\$0	\$0	(\$864,411)	(\$949,341)	(\$1,994,656)	(\$1,740,993)
Total Tax Levy	\$0	\$0	\$0	\$0	\$637,839	\$484,659	\$768,842	(\$668,694)
Mill Rate	\$0.00	\$0.00	\$0.00	\$0.00	\$0.10	\$0.07	\$0.11	-\$0.09

Scenario #4	Prior Years		Current 2025-26	Projections				
	2023-24	2024-25		2026-27	2027-28	2028-29	2029-30	2030-31
4K Class Size	0	0	0	0	0	0	0	0
Fund 10 Revenues	\$0	\$0	\$0	\$0	\$0	\$0	\$0	\$0
Fund 10 Expenditures	\$0	\$0	\$0	\$343,000	\$343,000	\$343,000	\$343,000	\$343,000
Surplus (Deficit)	\$0	\$0	\$0	(\$343,000)	(\$343,000)	(\$343,000)	(\$343,000)	(\$343,000)
Equalization Aid	\$0	\$0	\$0	\$0	(\$50,829)	(\$68,980)	(\$81,745)	(\$98,945)
Total Tax Levy	\$0	\$0	\$0	\$0	\$50,829	\$68,980	\$81,745	\$98,945
Mill Rate	\$0.00	\$0.00	\$0.00	\$0.00	\$0.01	\$0.01	\$0.01	\$0.01

Scenario #5	Prior Years		Current 2025-26	Projections				
	2023-24	2024-25		2026-27	2027-28	2028-29	2029-30	2030-31
4K Class Size	0	0	0	0	0	0	0	0
Fund 10 Revenues	\$0	\$0	\$0	\$0	\$0	\$0	\$0	\$0
Fund 10 Expenditures	\$0	\$0	\$0	\$300,000	\$300,000	\$300,000	\$300,000	\$300,000
Surplus (Deficit)	\$0	\$0	\$0	(\$300,000)	(\$300,000)	(\$300,000)	(\$300,000)	(\$300,000)
Equalization Aid	\$0	\$0	\$0	\$0	(\$44,456)	(\$60,330)	(\$71,497)	(\$86,542)
Total Tax Levy	\$0	\$0	\$0	\$0	\$44,456	\$60,330	\$71,497	\$86,542
Mill Rate	\$0.00	\$0.00	\$0.00	\$0.00	\$0.01	\$0.01	\$0.01	\$0.01

2026-2027 4K Planning Timeline

Date	November	December	January
1			
2			Potential 4K Enrollment begins.
3			
4			
5			
6			
7	Board Budget Committee Meeting 8:00am		
8		Board Regular Monthly Meeting 7:00pm	
9			
10	Board Regular Monthly Meeting 7:00pm		
11			
12	Virtual 4K Director & WCSD Administration 3:30pm		
13			
14			
15		4K Director WCSD Administration Meeting 3:30pm	
16			
17			
18			
19	Community School Funding Information Session 9:00am & 6:00pm	4K Notification via Docusign	
20			
21			
22			
23			
24			
25			
26			
27			
28			
29			
30			
31			



Waunakee School District

Monthly Actual Price and Usage History								
	2022		2023		2024		2025	
Month	Therms	Price	Therms	Price	Therms	Price	Therms	Price
Jan	43,377	\$0.588	50,238	\$0.735	39,385	\$0.382	48,812	\$0.4494
Feb	66,658	\$0.538	43,798	\$0.530	37,122	\$0.591	40,934	\$0.4479
Mar	51,616	\$0.690	41,092	\$0.336	33,894	\$0.433	28,098	\$0.4061
Apr	41,777	\$0.504	26,397	\$0.266	26,669	\$0.255	22,810	\$0.4026
May	31,007	\$0.620	18,670	\$0.248	21,154	\$0.206	16,904	\$0.3547
Jun	19,105	\$0.742	16,160	\$0.257	19,899	\$0.269	13,619	\$0.3837
July	15,981	\$0.961	17,913	\$0.292	17,445	\$0.291	12,781	\$0.3487
Aug	15,177	\$0.677	20,247	\$0.297	22,206	\$0.216	15,025	\$0.3466
Sep	17,185	\$0.896	16,903	\$0.280	15,915	\$0.215	14,367	\$0.3307
Oct	18,445	\$0.928	25,046	\$0.288	19,455	\$0.275		
Nov	25,056	\$0.619	33,973	\$0.338	24,740	\$0.332		
Dec	34,593	\$0.612	39,211	\$0.382	39,385	\$0.382		
Total	379,976	\$0.648	349,648	\$0.421	317,268	\$0.347	213,350	\$0.405

35

Cost Comparison Fixed Price vs Market Price							
	Fixed Price		Market Price			If 100% Market Price	
Month	Therms	Price	Therms	Price	Total	Dollars	Market Price vs Actual
Dec-24	23,060	\$0.3850	16,325	\$0.378	\$15,044	\$14,876	(\$168)
Jan-25	28,710	\$0.3850	20,102	\$0.542	\$21,943	\$26,442	\$4,499
Feb-25	22,090	\$0.3850	11,804	\$0.523	\$14,675	\$21,396	\$6,722
Mar-25	19,460	\$0.3850	7,209	\$0.454	\$10,763	\$12,749	\$1,986
Apr-25	14,010	\$0.3850	7,144	\$0.431	\$8,471	\$9,825	\$1,354
					\$70,895	\$85,288	\$14,392

Term	Future Pricing
Dec 25-Apr 26	\$0.526
Dec 25-Oct 26	\$0.471
Dec 25-Oct 27	\$0.477

Us Demand

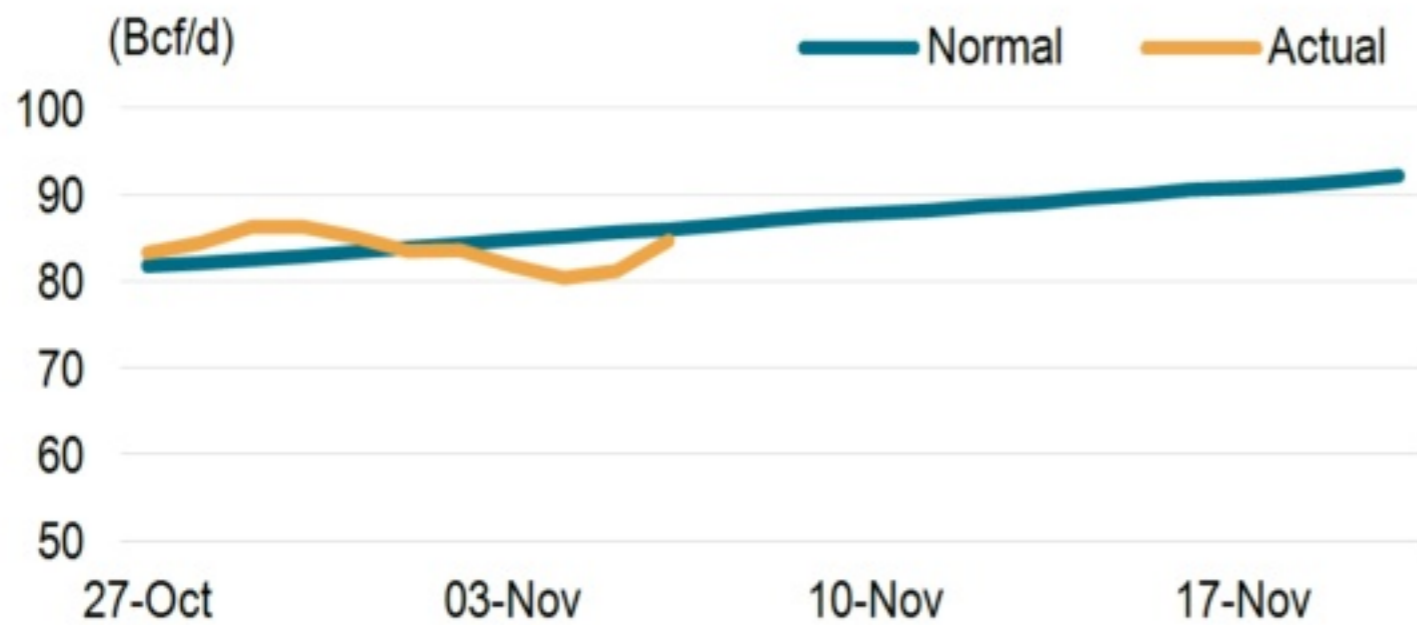

Source: S&P Global Commodity Insights.

Us Gas Storage Surplus Vs Rolling 5-Year Average

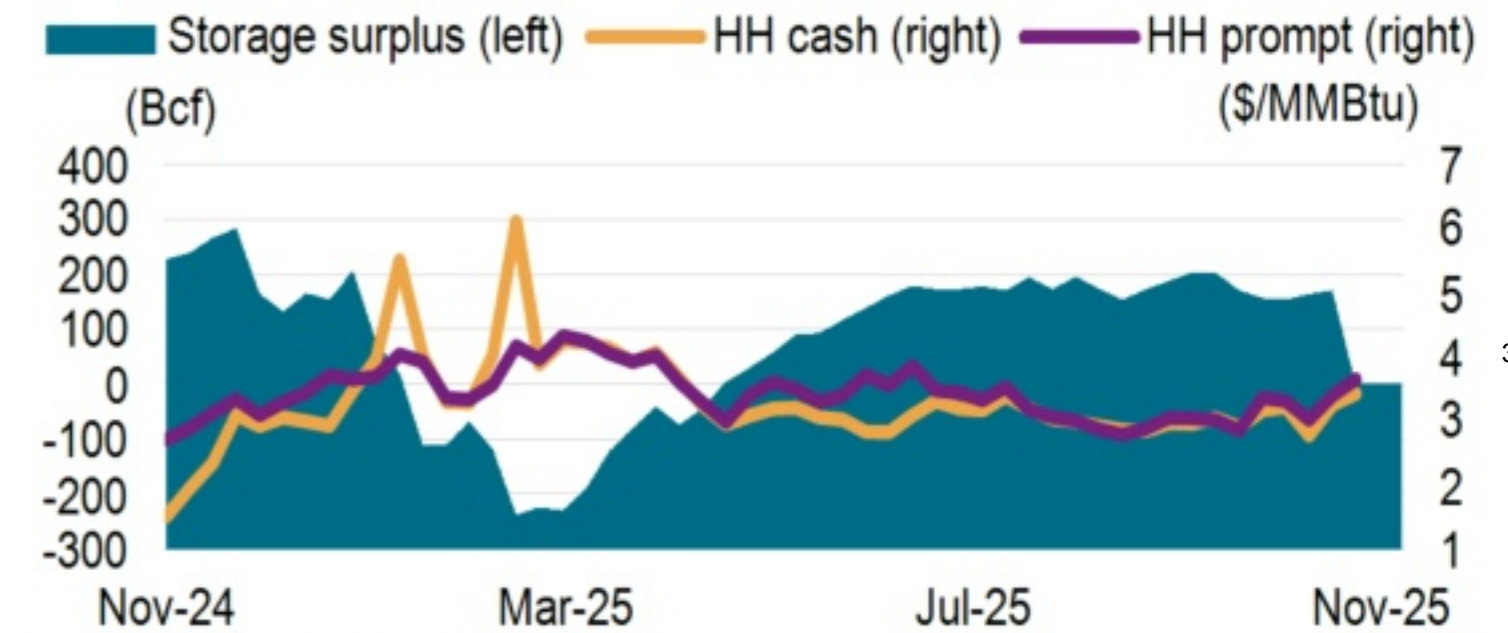

Source: S&P Global Commodity Insights.

US Gas Supply And Demand (Bcf/d)

	Recent								Forecast			HISTORY					
	31-Oct	01-Nov	02-Nov	03-Nov	04-Nov	05-Nov	06-Nov	Daily Change	07-Nov	Next 7		MTD Change			YTD Change		
										Day	8-14 Day	2025	2024	Change	2025	2024	Change
Dry Production	107.1	107.0	106.9	107.0	106.3	106.5	106.3	-0.2	106.4	106.5	106.6	106.7	102.2	4.5	106.0	101.9	4.1
Canadian Imports	5.6	5.7	5.8	5.7	5.4	5.7	6.0	0.3	6.1	6.1	6.1	5.7	6.0	-0.3	5.9	5.8	0.1
LNG Sendout	0.1	0.1	0.1	0.1	0.1	0.1	0.1	0.0	0.0	0.0	0.0	0.1	0.1	0.0	0.1	0.1	0.0
Total Supply	112.8	112.8	112.8	112.8	111.8	112.3	112.4	0.1	112.5	112.6	112.7	112.5	108.3	4.2	112.0	107.8	4.2
Power Burn	30.0	27.8	28.2	28.9	28.2	29.6	28.5	-1.1	28.6	30.1	30.2	28.5	33.3	-4.8	36.9	37.6	-0.7
Industrial	23.9	23.9	23.9	23.4	23.4	23.5	23.8	0.3	23.5	23.8	23.6	23.7	23.5	0.2	23.3	23.0	0.3
ResComm	23.6	24.3	24.0	22.2	21.7	20.8	24.8	4.0	20.5	26.5	24.1	23.0	18.0	5.0	20.1	18.1	2.0
Mexican Exports	5.8	5.7	5.8	5.9	5.6	5.5	5.6	0.1	5.7	5.7	5.7	5.7	5.7	0.0	6.4	6.5	-0.1
LNG Feedgas	17.9	17.5	16.7	17.5	17.8	17.4	17.4	0.0	17.5	17.5	17.5	17.4	12.3	5.1	15.5	12.8	2.7
Pipe Loss	7.6	7.5	7.5	7.3	7.1	7.3	7.6	0.3	7.6	7.7	7.7	7.4	7.5	-0.1	8.0	7.8	0.2
Total Demand	108.8	106.7	106.1	105.2	103.8	104.1	107.7	3.6	103.4	111.3	108.8	105.7	100.3	5.4	110.2	105.8	4.4
Balance	-0.3	-0.3	-0.3	-0.3	-0.3	-0.3	-0.3	0.0	-0.4	-0.5	0.0	-0.3	-0.3	0.0	-0.2	-0.3	0.1
Implied Storage Chg	3.7	5.7	6.2	7.1	7.6	7.9	4.4	-3.5	9.2	1.5	4.0	6.5	7.6	-1.1	1.7	1.7	0.0
Temps vs. Normal	-1.5	-2.1	-1.9	0.3	1.8	3.3	1.1	-2.2	3.4	-0.4	3.8	0.4	6.1	-5.7	0.9	2.4	-1.5

www.spglobal.com/commodityinsights



2025 Summer School in Review

DPI Reports for the past 10 years:

Year	Full Time Equivalency	Days Offered	Residents Enrolled	Non-residents Enrolled
2025	205	24	2833	0
2024	188	23	2690	0
2023	173	22	2603	0
2022	166	22	2568	0
2021	160	23	2320	0
2020	120	24	1989	0
2019	185	23	2760	9
2018	175	22	2609	8
2017	168	22	2464	22
2016	167	23	2513	22

Enrollment: Headcount of all students who have enrolled and attended at least one class.

FTE (Full Time Equivalency): Determined by totaling all student membership minutes and dividing by 48,600 (one FTE). FTE is used by the state when calculating the aid payment to the district.

2025 Summer School Highlights:

- **Registrations:** The district had a 1.78% increase in summer school registrations in 2025. We had the highest number of registrations in the program's history with a total of 9,601 class registrations. It resulted in 17 additional FTEs that were earned this summer. That was a 9.2% increase in FTEs. We had 2,833 students participate in Summer School in 2025. That is 64.8% of our student population that participated in the summer school program.
- **Growth:** In the last decade, Waunakee Community School District's student count has grown by 9.5%. During that same time period, the summer school student count has grown by almost 23%.

- **Course Offerings in 2025:** We offered additional sections of some existing courses at the elementary level in 2025. This in part increased the FTEs at the elementary level by almost 6 FTEs. We also offered two new courses at the Intermediate level. This also in part increased our FTEs at that level by almost 6 FTEs. FTEs also increased due to increased daily attendance.
- **Online Personal Finance:** An Online Personal Finance course was added for HS students. This was done because DPI added that course as a graduation requirement. The Online Finance course was added for Summer School 2025 and will be added in 2026 to allow students who missed the opportunity to take that course earlier in their HS career to take it in the summer to make up that new graduation requirement. In Summer School 2025, the district gained an additional 4.17 FTEs from offering this course. We expect the impact in 2026 to be less and those FTEs will be gone in 2027 should the course sunset.
- **Staffing:** There were 350 Summer School Staff contracts in 2025. This was a 5.5% increase from 2024. The increase was because of staffing for the additional course offerings. We also needed an additional 10 special ed paras this summer to support students.
- **Calendar for classes:** In the past, we offered six weeks of summer school first and then week seven was Camp Invention. In 2024 and 2025, we offered Camp Invention first and then the six weeks of summer school. This switch was done to provide summer school staff more time to set up their classrooms, order supplies and have supplies in house before the first day of school. This change has been favorably received by both parents and staff. As a reminder, we added the third full camp, increasing FTE considerably last year. This same FTE was held this year as we are continuing to run three full camps. We anticipate keeping this type of calendar moving forward.
- **July 4th Holiday:** Summer School 2025 core courses ran for 24 days this summer, because of when the holiday fell.
- **Remedial Registrations:** An analysis of past data showed that over the last five years, 75% of the students recommended for remedial summer school courses actually are registered for their recommended course. That percentage was very consistent from year to year. Remedial recommendations and registrations for 2025 were statistically similar to 2024. We are hopeful that future Next Path will allow us more data information to compare student achievement of those that attended and those that did not attend.

Looking Ahead:

- **Alternate Transportation:** We need to look at revising the alternate transportation policy for Summer School. The current policy of daily unlimited options for parents creates student safety concerns for our youngest learners.
- **Middle School:** 2026 Summer School is planning on using the new Middle School for 2026 MS Summer School classes.
- **HS credit recovery process:** There was a 50% decrease in registrations for credit recovery classes in 2025. 38.5% of the time staff contracted for those

summer school classes had no students in the classroom. The administration will be reviewing the way we currently plan for and serve remedial class needs. Shorter calendars may be helpful. We will look for ways to restructure and improve this area of summer school to better fit student needs and attendance.

- **Staff Badges for Summer School Employees:** We will be working on ways to expand badges for summer school staff.
- **Reports for Student Support needs:** We currently run summer school reports that identify students registered for summer school that need support because of health needs, ELL or special ed. The reports are used to get appropriate staff support in place for those students and get that staff trained prior to the start of summer school. In 2026, we want to add a report for McKinney Vento students to help identify any support needs or accommodations they might need as well, especially as it relates to transportation.
- **Adaptive Swim Lessons:** We will be looking at restructuring and adding an additional section of the Adaptive Swim Lessons offered in 2026.
- **Attendance Reporting for our Translation Families:** We will be looking at ways to make reporting summer school absences easier for our translation required families.
- **Summer School Communications:** For 2026, the Summer School Office will be preparing and sharing with Communications and IT parent contact information (email and text) for students registered for summer school. They will also be provided staff contact information as well. There will be contact groups created by building, session and/or course. Those will be provided prior to the start of summer school. In the event of any incident occurring during summer school, Communications will be able to get the appropriate communication out to the appropriate parties.
- **Process to Review Registration Vendor:** We will begin a review process of vendor selection for registration for 2027. We may be staying with our current vendor, but will review with stakeholders on the best fit for our district. Our registration system drives registration as well as predicting staffing and produces our DPI report.

2025 SUMMER CLASS OFFERINGS

Ordered by grade grouping. Please refer to the catalog description for details.
Classes should be selected based on the grade your student will be in the 2026-27 school year.

Grades K -4			
ENRICHMENT (3 week classes)	Fees	REMEDIAL (6 week classes)	Fees
CAMP KINDERGARTEN	K \$0	READY, SET, GO- READING	1 \$0
ACTIVE FUN FITNESS	1-4 \$0	READY, SET, GO- MATH	1 \$0
ARTS AND CRAFTS	1-4 \$0	JUMP START MATH	2-4 \$0
BRAIN GAMES	1-4 \$0	READING EXPRESS	2-4 \$0
BUILD IT	1-4 \$0	ENHANCING SKILLS ELE	1-4 \$0
LEGOS	1-4 \$0		
MAKING MUSIC	1-4 \$0		
BOOK CLUB	1-2 \$0		
CODING	1-2 \$0		
GOING BUGGY	1-2 \$0		
BOOK CLUB	3-4 \$0		
DUCTIVITY	3-4 \$0		
SCIENCE WORLD	3-4 \$0		
CODING	3-4 \$0		
CAMP INVENTION	1-6 \$ 75		

Grades 5-6			
ENRICHMENT (6 week classes)	Fees	REMEDIAL (6 week classes)	Fees
CODING AND GAME DESIGN	5-6 \$0	COMMUNICATION ARTS 5-6	5-6 \$0
CRAFTY CREATIONS	5-6 \$0	MATH 5-6	5-6 \$0
ESCAPE ROOM CHALLENGE	5-6 \$0	ENHANCING SKILLS WIS	5-6 \$0
GAMING	5-6 \$0		
GET IN THE GAME	5-6 \$0		
GET READY TO BABYSIT	5-6 \$0		
IMPROV COMEDY THEATER	5-6 \$0		
INVASION OF THE TOADS	5-6 \$0		
KEYBOARDING	5-6 \$0		
MAD SCIENTIST'S WORKSHOP	5-6 \$0		
PHOTOSHOP	5-6 \$0		
SCIENCE OF SUPERHEROES	5-6 \$0		
SUMMER FITNESS	5-6 \$0		
THE ARTIST IN YOU!	5-6 \$0		

Grades 7-12			
ENRICHMENT (6 week classes)	Fees	REMEDIAL (6 week classes)	Fees
ACT TEST PREP	10-12 \$0	COMMUNICATION ARTS 7-8	7-8 \$0
CALL OF THE WAUNAKEE WILD	7-8 \$0	ENHANCING SKILLS MS	7-8 \$0
CAMP INVENTION JUNIOR COUNSELOR	7-9 \$75	MATH 7-8	7-8 \$0
PLANTS TO PLASTIC AND GEAR	7-8 \$0	ENHANCING SKILLS HS	9-12 \$0
PODCASTING/RADIO BROADCASTING	7-8 \$0	REMEDIAL ENGLISH	10-12 \$0
STRENGTH AND CONDITIONING - MS BOYS	7-8 \$0	REMEDIAL MATH	10-12 \$0
STRENGTH AND CONDITIONING - MS/HS GIRLS	7-12 \$0	REMEDIAL SCIENCE	10-12 \$0
STRENGTH AND CONDITIONING - HS CO-ED	9-12 \$0	REMEDIAL SOCIAL STUDIES	10-12 \$0
STRENGTH AND CONDITIONING - HS GIRLS	9-12 \$0		
AUGUST STRENGTH TRAINING	7-12 \$0		
SUMMER ART	7-8 \$0		
HS ONLINE ENRICHMENT(virtual)	10-12 \$0		
ONLINE FINANCE(virtual)	10-12 \$0		
ONLINE PHY ED(virtual)	10-12 \$0		
SUMMER TEACHING ASSISTANT	10-12 \$0		

MUSIC 5-12			
ENRICHMENT (6 week classes)	Fees	ENRICHMENT (6 week classes)	Fees
BAND 6	6 \$0	ORCHESTRA 5	5 \$0
BAND 7-8	7-8 \$0	ORCHESTRA 6	6 \$0
BAND 9-12	9-12 \$0	ORCHESTRA 7-8	7-8 \$0
GROUP PIANO LESSONS	7-9 \$0	ORCHESTRA 9-12	9-12 \$0
GROUP GUITAR LESSONS	8-9 \$0		
MUSIC CAMPS	7-12 \$0		

SWIM K - 12)			
Classes are 2 weeks M - TH	Grade Fees	REMEDIAL (2 week classes)	Grade Fees
LEARN-TO-SWIM LEVELS 1-6	K-11 \$0	ADAPTED AQUATICS	K-12+ \$0
4K SWIM LESSONS LEVELS 1-3	4K \$0		
MS/HS- BASIC SKILLS	7-12 \$0		



WAUNAKEE
COMMUNITY SCHOOL DISTRICT

41

DEI Overview 2025-2026



Committee Structure

- Board of Education DEI Committee
- DEI Steering Committee
- Comprehensive 3 Year DEI Plan



Areas of Focus

- Increase sense of belonging
- Improve academic outcomes
- Decrease behavioral incidents



Academics: Multi-Tiered Systems of Support (MTSS)

- MTSS is a framework schools use to provide targeted support to struggling students.
- The goal of MTSS is to intervene early so students can catch up with their peers. 44
- It screens all students and aims to address academic and behavior challenges using a tiered approach to interventions.
 - Tier 1 - Universal Instruction
 - Tier 2 - Small intervention groups
 - Tier 3 - Intensive targeted intervention in small groups
- ***MTSS Work Group: Examine System Bias***



Sense of Belonging: Professional Development

- Expansion of Restorative Practices
- Belonging and Engagement Walks
- Equal Opportunity Schools
- “You Belong” Statements
- Implicit Bias



Partnerships





Equal Opportunity Schools

Elizabeth Hernandez



10th Grader

Interested in helping outreach

Trusted Adults
• John Katinsky
• Mike Kohl

Staff Advocates

Study Skills Support
• Jack Little
• Mike Kohl

Stats  **GPA 2.83**    **AP Comparable**

STAR Reading 1218/1400
PSAT89 EBRW 570/800
PSAT Total 1010/1600
PSAT89 Math 540/800

Aspirations

Educational Goal
Advanced Degree

Curriculum Program Interest
    

General Interest
  

Learning Mindsets and Skills
Community Leadership **Growth Mindset**
Purpose for Learning **Focus** **Grit**

Reported Barriers
Adult Encouragement Barrier
ULC Belonging Barrier
Welcome Barrier
School Access Barrier

Career Interest
I would like to be an activist or a spokesperson for a cause or organization.

Who I am as a Student
I'm really interested in Science and Math, and I try to get the highest class I can be in without having to struggle too much. When I face obstacles, I try to push through or, if I am really stressed, I move on to other things and go back to it later.

Would Like the School to Know
I try my hardest to get the highest grades possible.

Other Readiness Indicators
• Currently Enrolled in Advanced Courses
• Feels Classes are not Adequate Preparation for College

Student has enrolled in AP, but states:
• I don't think I can be successful/get a good grade
• I am not sure I would have classmates to study with or partner with for projects
• I am worried it might hurt my GPA

More likely to take AP if:
• I know that I would have classmates to study or partner with
• I could get extra study/homework support
• I would have access to help from student who took the class before



Universal Instruction

- Develop lessons for all grades that address hate speech/inappropriate language
- Speak Up Training
- Develop lessons for special observance months



Family Engagement

- Access to interpreters
- Transportation to school sponsored events
- Engaging parents in hiring processes
- Introduce text messaging capabilities
- Focus group: parents of students with disabilities
- Parent Night



Policies/Procedures

- Implement revised harassment policy
- Develop a plan for progressive response to harassment behavior incidents
- Continue development of content for special observance months

Questions?



WAUNAKEE

COMMUNITY SCHOOL DISTRICT

52

Waunakee Community High School

Summer 2026

October 30, 2025

VOGEL
BROS. BUILDING CO.



Mission, Vision, and Equity Statements

- **Mission Statement:** “Committed to Children...Committed to Community...Committed to Excellence”
- **Vision Statement:** The Waunakee Community School District is a collaborative learning community that works with students, staff, families, and the community to ensure that every student is ready for college and career; through a focus on data, research based best practices, and engagement with students to be active partners in their learning.
- **Equity Statement:** The Waunakee Community School District embraces the differences among our students, staff, and families. We work to provide a safe environment with access to resources, opportunities, and instruction for all students to reach their full potential in the classroom and beyond. We strive to create a culture of dialogue, acceptance, and inclusion. We are committed to engaging all students so that they may thrive academically, socially, and emotionally in an ever-changing multicultural society.

Agenda and Timeline of Events

- Goals
 - Focus on Students
 - Focus on Staff
 - Board Goal #1 - Academic Achievement
 - High School Long Term Planning (Longevity)
- Timeline
 - Scope, Time, Cost
- Scope of work for discussion
- Next steps

High School Campus

- **Long term planning**
 - Create a modern high school campus
 - One building - students to receive instruction in existing high school building during the school day
- **Short term planning**
 - Provide high school administration with the option to utilize the existing middle school⁵⁵ (south campus) building for high school student use
 - Short term financial decisions are tied to long term goals as much as possible
 - Continue to offer high school FACE cooking class that is taught at the middle school building (south campus)
 - Maximize the opportunity for teachers to have their own classroom
 - Additional lunch opportunities for students looking for a less crowded environment
 - WaunaGrow special education program (K-8) housed in existing middle school (south campus)

Summer 2026 Schedule and (SHORT TERM) Time Frame-Board of Education - November 26 Referendum

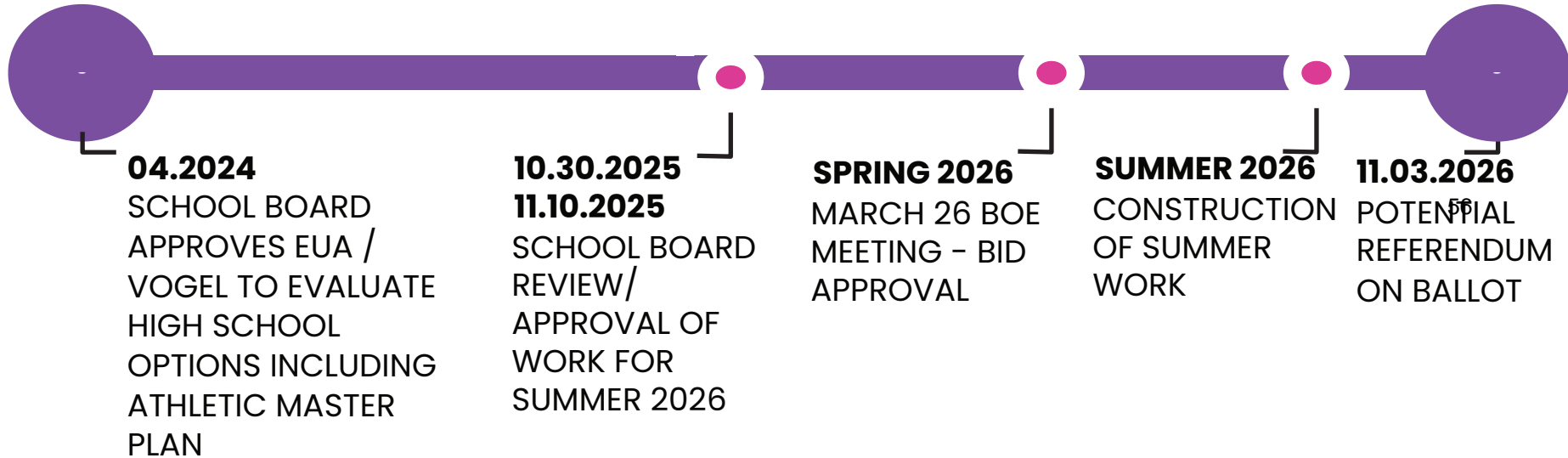

Summer 2026 Schedule and (SHORT TERM) Time Frame-Board of Education - No Referendum in 2026

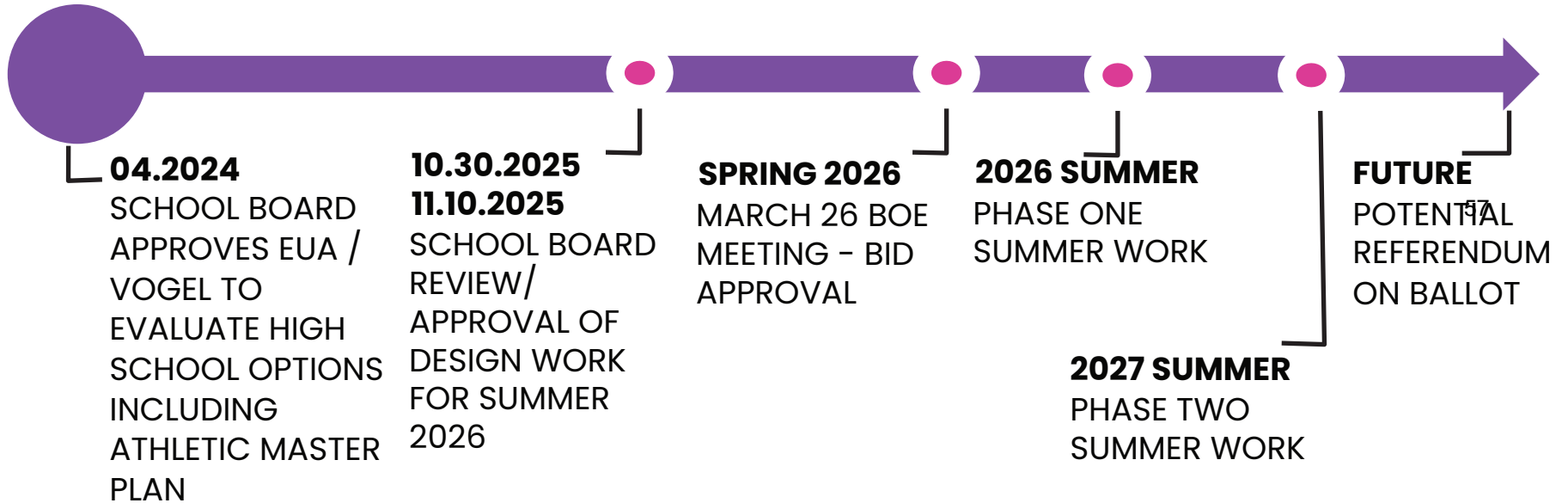

Summer 2026 Proposed Scope of Work - Budget Summary

	Construction	Soft Cost	Total
Site Safety	\$ 275,341	\$ 20,650	\$ 295,991
Building Safety/Security South (existing MS)	\$ 716,947	\$ 63,682	\$ 780,629
Classrooms - HS Department Move	\$ 104,793	\$ 466,909	\$ 571,702
Classroom FACE	\$ 145,673	\$ 46,241	\$ 191,914 ⁵⁸
Cafeteria	\$ 34,381	\$ 157,455	\$ 191,836
WaunaGrow (K-8)	\$ 214,199	\$ 48,893	\$ 263,092
Softball Press Box	\$ 243,350	\$ 18,250	\$ 261,600
		Total:	\$2,556,764

- Assumptions:
- 10% Contingency Included
- Based on work happening summer 2026
- Based on all projects happening concurrently

Site Safety - \$ 295,991

- Traffic study in board book
- 3 controlled gates
 - Used for short term and long term plan
- Change traffic flow to return cars back west during school day

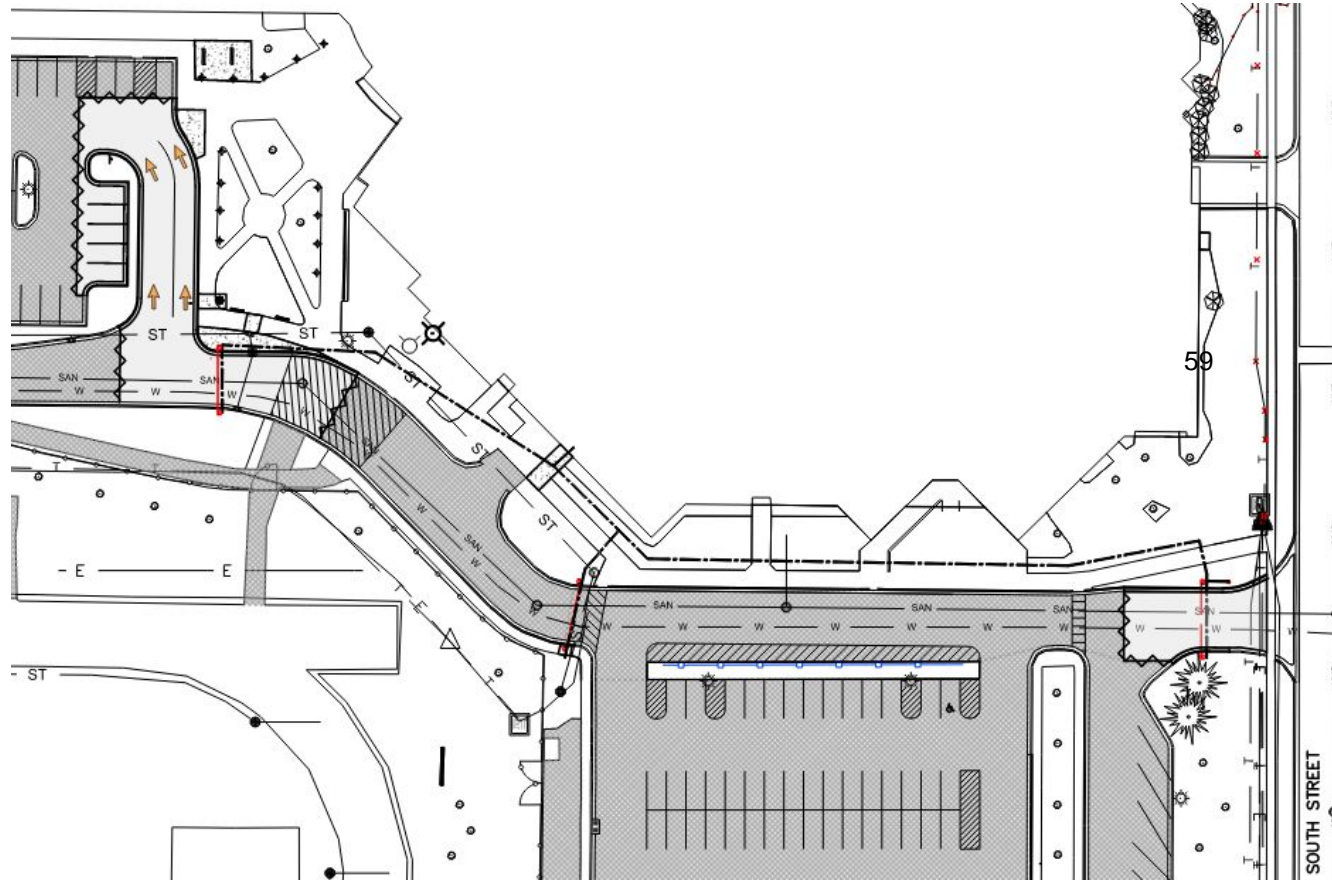

Building Safety/Security - Middle School - \$ 780,629

- Clock, Bell, PA, Security/Attendance Office
- New security/attendance office:
 - New flooring, new ceiling, door and transaction window
- Double doors at North Entry
- Convert Laundry Room to Janitor Closet:
 - Remove washer/dryer, add mop sink
- Main Office - no work

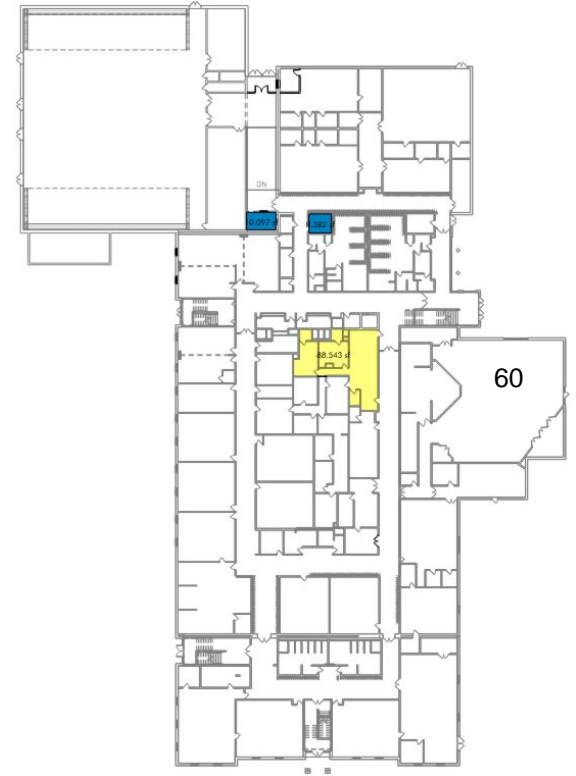

SOUTH- FIRST FLOOR

-  SPACE TO BE USED,
NO WORK NEEDED
-  SPACE TO BE USED WITH
LIGHT RENOVATION
-  SPACE TO BE USED WITH
HEAVY RENOVATION

Classrooms - HS Department Move - \$ 571,702

- 13 classrooms:
 - Age-appropriate furniture
 - New carpet in 4 classrooms
 - Located to access natural light

-  SPACE TO BE USED, NO WORK NEEDED
-  SPACE TO BE USED WITH LIGHT RENOVATION
-  SPACE TO BE USED WITH HEAVY RENOVATION



SOUTH- SECOND FLOOR

Classrooms-FACE - \$ 191,914

- Demo stations for FACE cooking classrooms:
 - Add a demo station to North and South Campus FACE Labs. Casework, electrical and mechanical modifications
 - Document cameras and screens to allow for better demonstration of skills

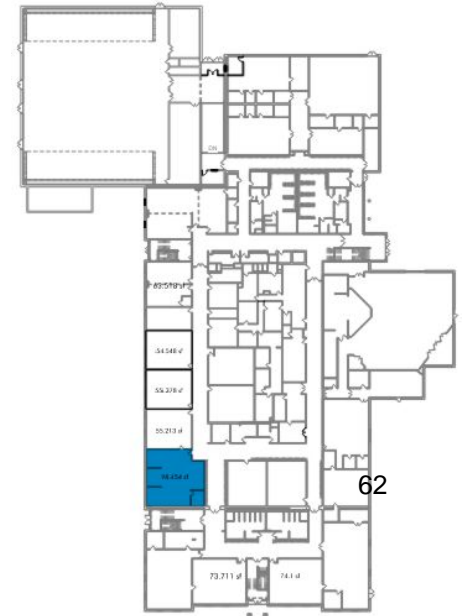
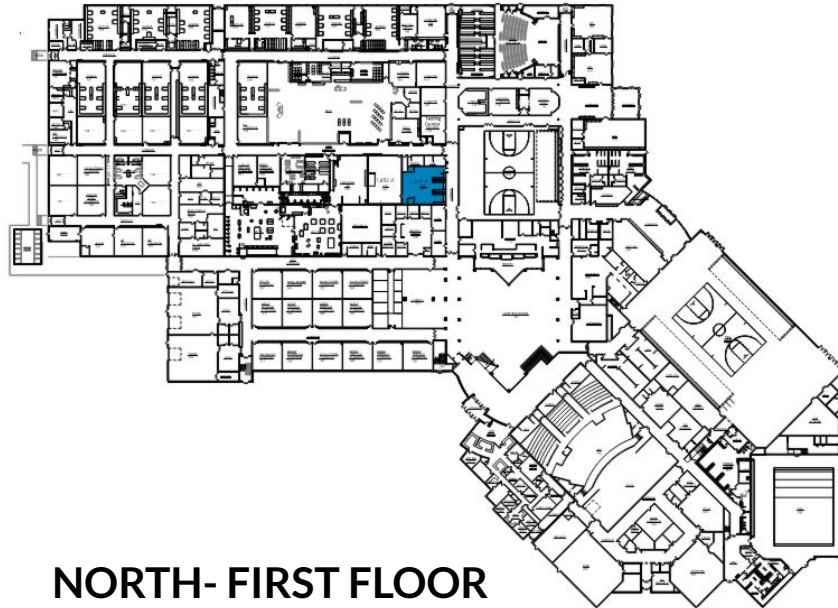

Gymnastics

- Gymnastics space
 - No work



SOUTH- FIRST FLOOR

-  SPACE TO BE USED,
NO WORK NEEDED
-  SPACE TO BE USED WITH
LIGHT RENOVATION
-  SPACE TO BE USED WITH
HEAVY RENOVATION

Cafeteria - \$191,836

- Cafeteria - provide a smaller lunch area
 - Age-appropriate furniture
 - Paint



SOUTH- FIRST FLOOR

 SPACE TO BE USED,
NO WORK NEEDED

 SPACE TO BE USED WITH
LIGHT RENOVATION

 SPACE TO BE USED WITH
HEAVY RENOVATION

WaunaGrow (K-8) - \$ 263,092

- Eliminate the need for rental space
- New interior walls, casework, flooring, ceilings, openings, kitchenette, electrical and mechanical modifications, plumbing
- New exterior signage for wayfinding

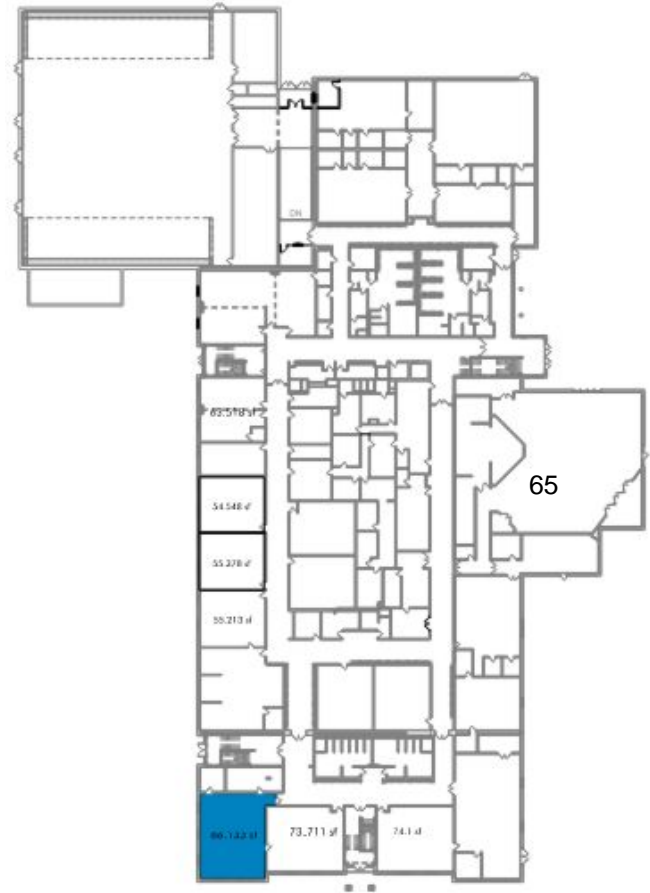

SOUTH- FIRST FLOOR

-  SPACE TO BE USED,
NO WORK NEEDED
-  SPACE TO BE USED WITH
LIGHT RENOVATION
-  SPACE TO BE USED WITH
HEAVY RENOVATION

Softball - \$ 261,600

- Press box and storage
 - Similar to existing facilities at former varsity softball field
 - Press box
 - Storage
 - Ticket/concessions window
 - Fence modifications

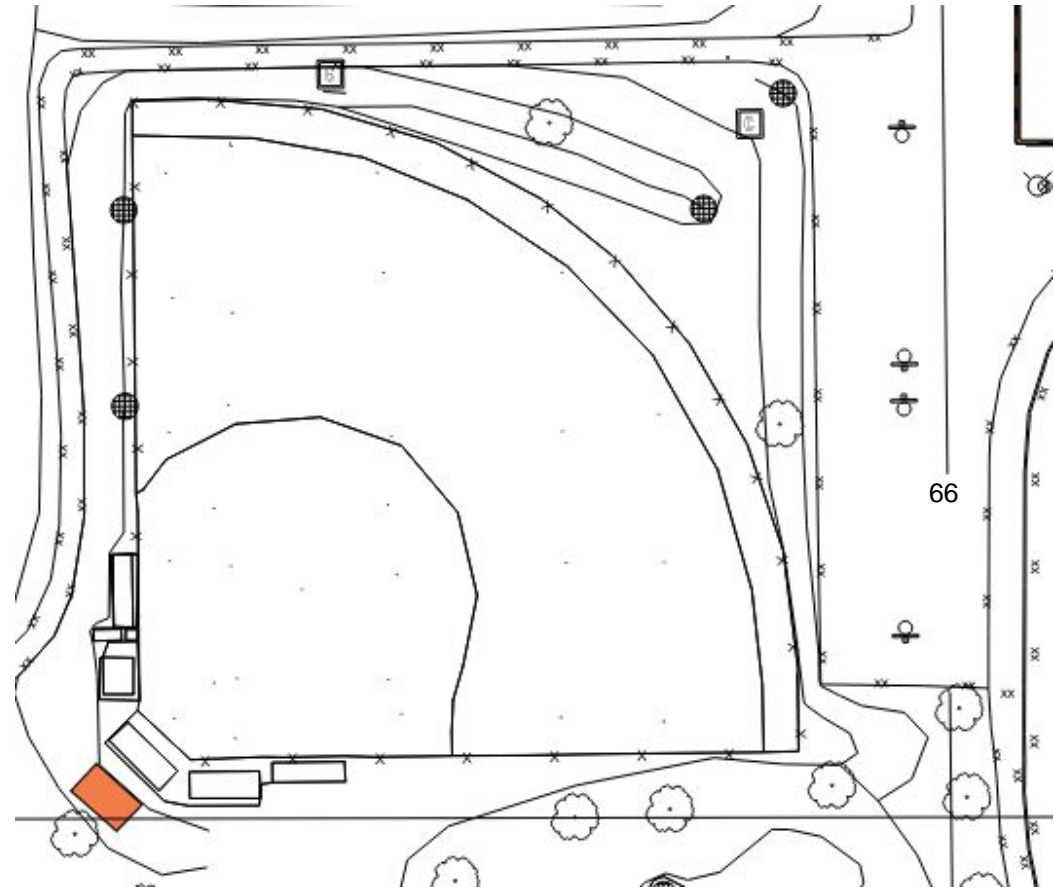

 SPACE TO BE USED WITH HEAVY RENOVATION

 NEW CONSTRUCTION

SITE PLAN

Team Room/Inclement Weather Area - \$ 790,000

- (1) Inclement weather area/Team rooms
 - New construction
- Locker area/team meeting space
- Toilet rooms for team use
- Trainer room
- Masonry construction, precast plank roof
- Mechanical, Electrical and Plumbing

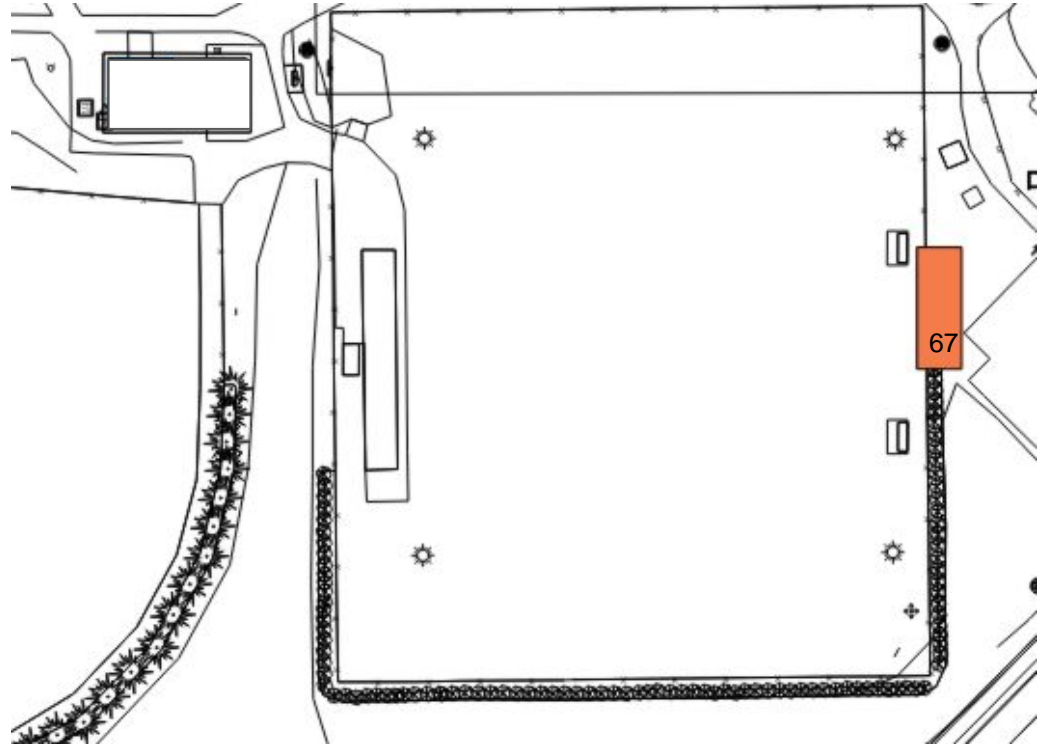

 NEW CONSTRUCTION

SITE PLAN

Summer 2026 Proposed Scope of Work - Budget Summary

	Construction	Soft Cost	Total
Site Safety	\$ 275,341	\$ 20,650	\$ 295,991
Building Safety/Security South (existing MS)	\$ 716,947	\$ 63,682	\$ 780,629
Classrooms - HS Department Move	\$ 104,793	\$ 466,909	\$ 571,702
Classroom FACE	\$ 145,673	\$ 46,241	\$ 191,914
Cafeteria	\$ 34,381	\$ 157,455	\$ 191,836 ⁶⁸
WaunaGrow (K-8)	\$ 214,199	\$ 48,893	\$ 263,092
Softball Press Box	\$ 243,350	\$ 18,250	\$ 261,600
		Total:	\$2,556,764

- POTENTIAL FUNDING SOURCES:
 - ORIGINAL HIGH SCHOOL REFERENDUM SCOPE NOT COMPLETED \$ 1,320,000
 - DEDUCTIVE CHANGE ORDER - PORTION OF NEW MIDDLE SCHOOL SAVINGS \$ 1,240,000

TOTAL \$ 2,560,000
- DESIGN FEE RANGE \$80,000-\$140,000; INCLUDES ARCHITECTURE, ENGINEERING AND FURNITURE SERVICES
(HIGH END OF THE RANGE IS INCLUDED IN THE COSTS ABOVE)

***FINAL FUNDING SOURCES AND BIDS PROPOSED TO BE APPROVED IN EARLY SPRING 2026**

Removal of Scope

- 2022 Not spent
 - Pool locker room and family room
 - Large group instructional space
 - Deferred Maintenance
 - Interior Finishes

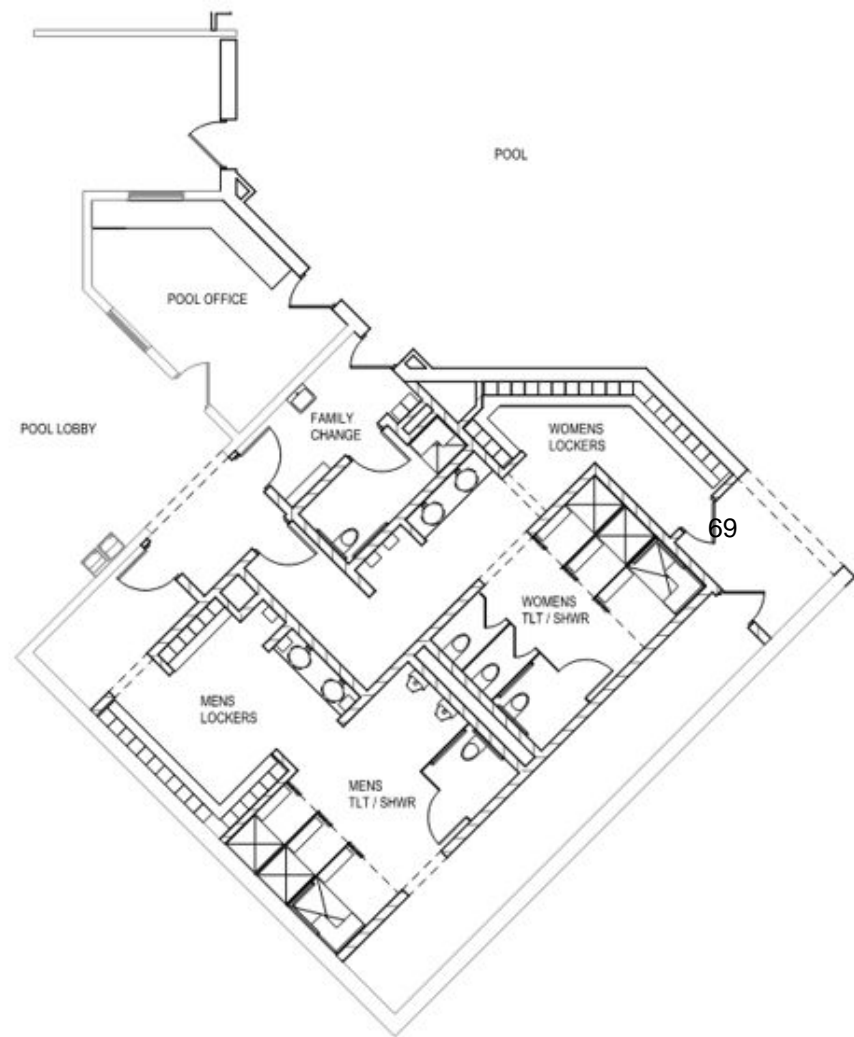

Summer 2027 Scope?

- 4K
- Fitness
- Wellness Clinic
- Peer Tutoring
- Health/Nurse
- Student Services
- World Language
- Warrior Media
- Science
- Math
- Large Group Assembly
- Conference Rooms
- Facilities Maintenance Storage
- Team Rooms/Inclement Weather Area

Next Steps

- November 10th
 - EUA and Vogel assist with answering additional questions you may have
 - Budget estimates will be provided
 - District administration will review resources that are available for consideration
 - Board to identify what scope (if any) will proceed for summer of 2026 work to be completed by September 1, 2026
- November 11th - If approved design and documentation will start.
- Winter 2026 - Documents released for bids
- March 2026 - Bids approved by School Board
- June 2026 - Construction starts



Fitness

- Fitness/Weight room
 - Convert music suite to a fitness/weight room
 - Allows for more student use
 - Demo existing walls, remove flooring
 - New walls, flooring, ceiling, openings, plumbing, electrical and mechanical modifications.

 SPACE TO BE USED,
NO WORK NEEDED

 SPACE TO BE USED WITH
LIGHT RENOVATION

 SPACE TO BE USED WITH
HEAVY RENOVATION

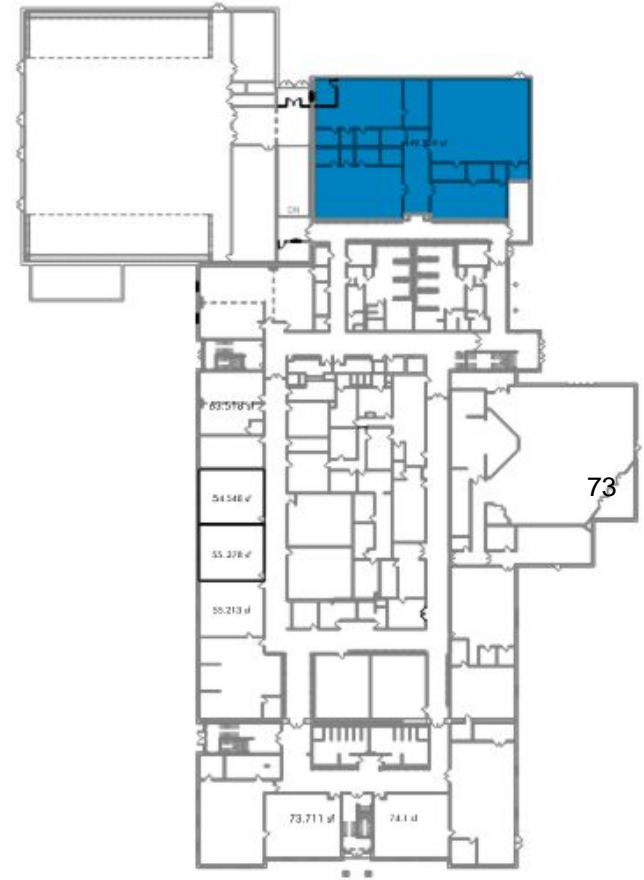

SOUTH- FIRST FLOOR

Wellness Clinic

- Eliminate the need for rental space
- New interior walls, casework, flooring, ceilings, openings, kitchenette, single use bathroom, plumbing, electrical and mechanical modifications
- New exterior signage for wayfinding

-  SPACE TO BE USED,
NO WORK NEEDED
-  SPACE TO BE USED WITH
LIGHT RENOVATION
-  SPACE TO BE USED WITH
HEAVY RENOVATION

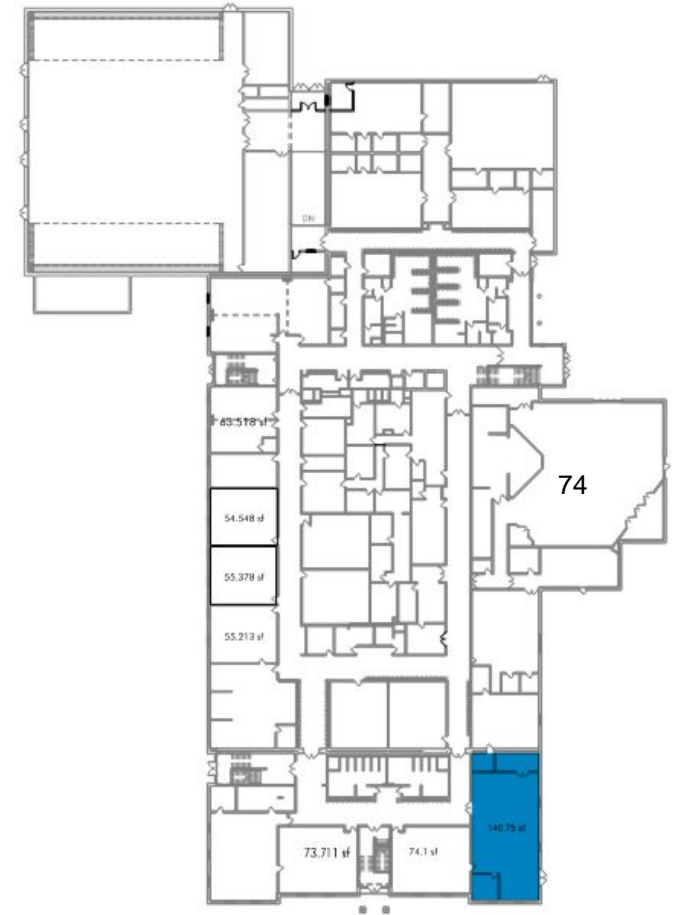

SOUTH- FIRST FLOOR

Peer Tutoring

- Use vacated offices for more privacy with peer tutoring.
- Age appropriate furniture
- Additional glass for passive supervision.

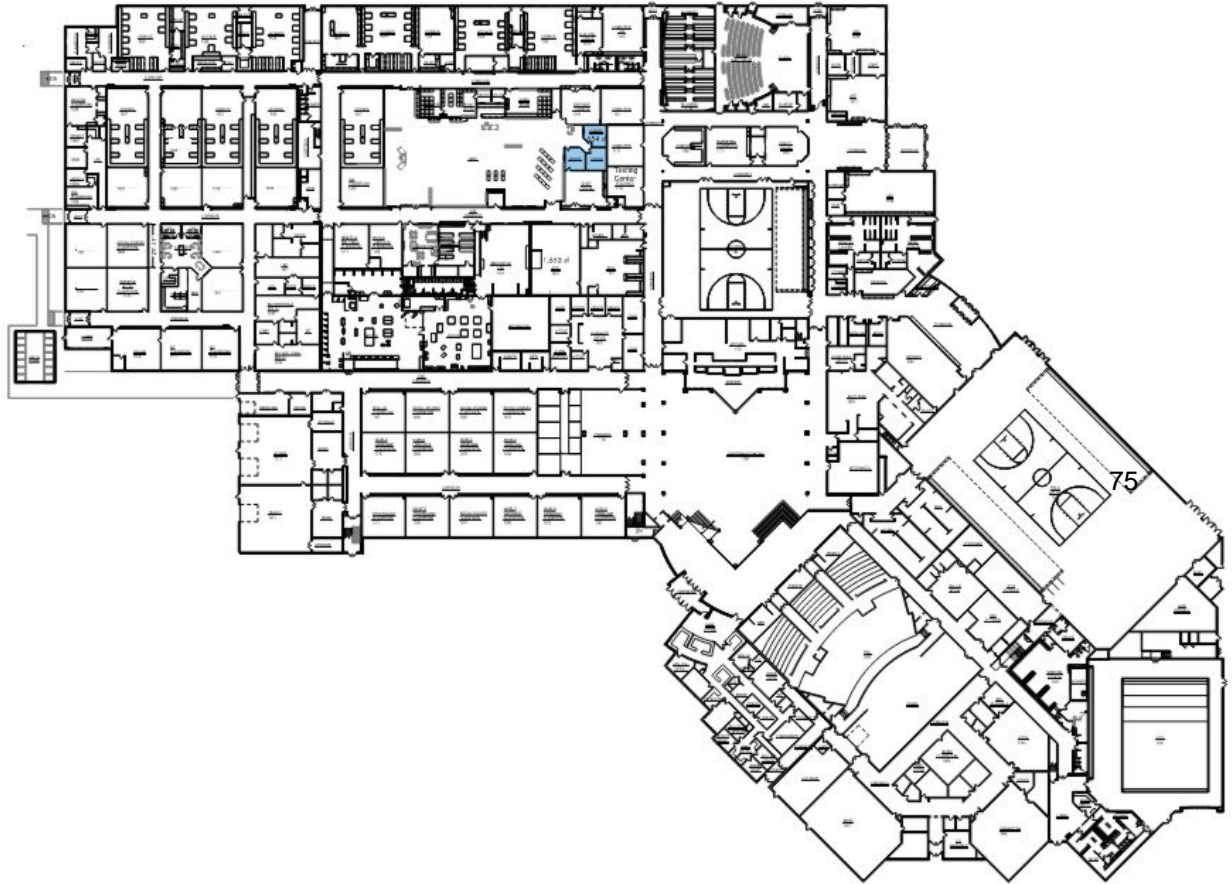

-  SPACE TO BE USED,
NO WORK NEEDED
-  SPACE TO BE USED WITH
LIGHT RENOVATION
-  SPACE TO BE USED WITH
HEAVY RENOVATION

NORTH- FIRST FLOOR

Health/Nurse

- Additional health treatment room
- Dedicated nurse office
- New walls, flooring, ceiling, openings, electrical and mechanical modifications, plumbing

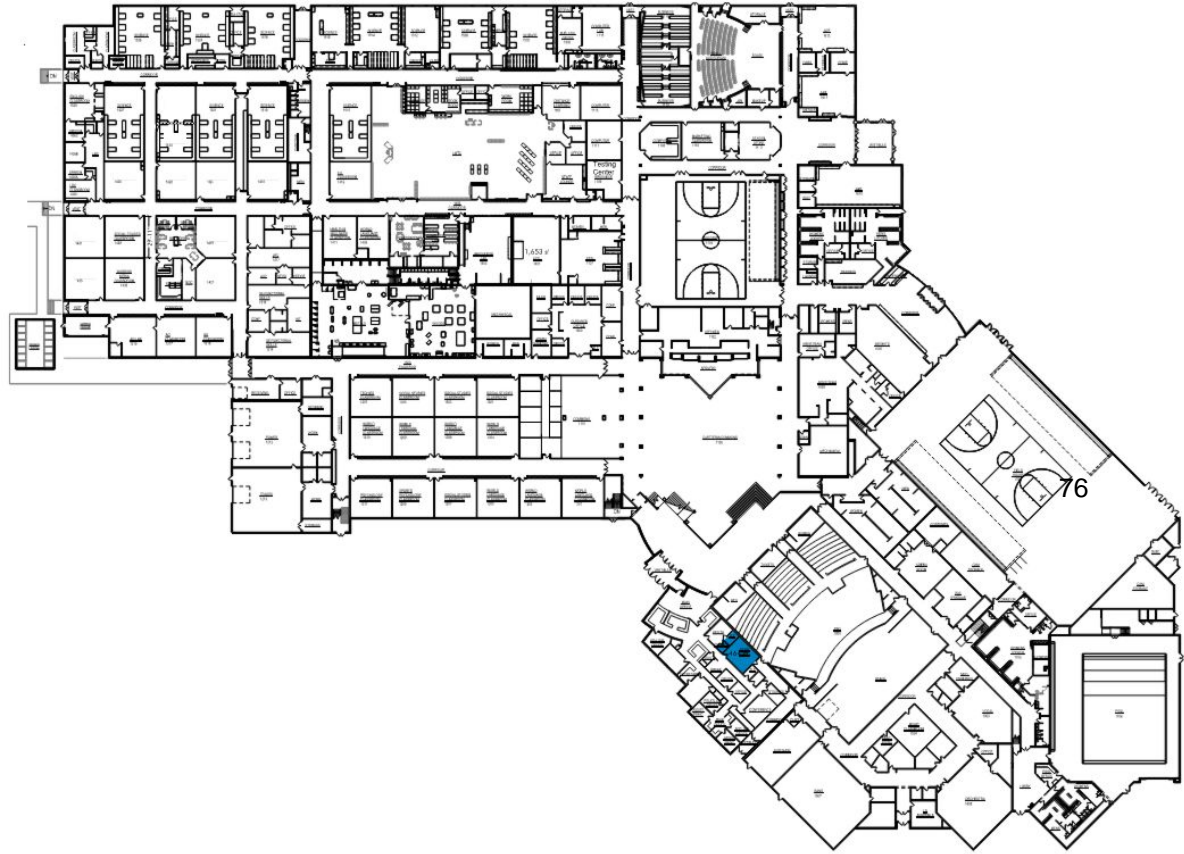

-  SPACE TO BE USED, NO WORK NEEDED
-  SPACE TO BE USED WITH LIGHT RENOVATION
-  SPACE TO BE USED WITH HEAVY RENOVATION

NORTH- FIRST FLOOR

Student Services

- Additional offices
- Telehealth space
- Reflection room
- New walls, flooring, ceiling, openings, electrical and mechanical modifications

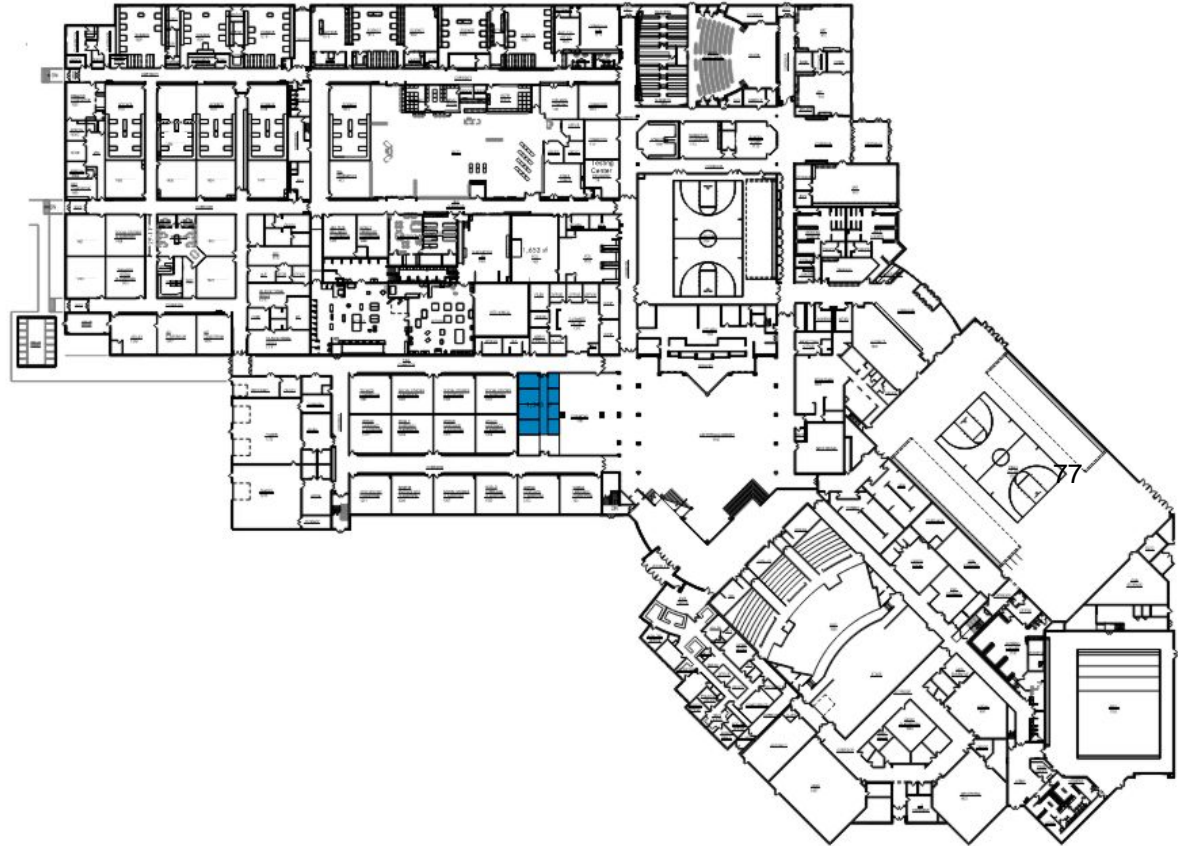

-  SPACE TO BE USED, NO WORK NEEDED
-  SPACE TO BE USED WITH LIGHT RENOVATION
-  SPACE TO BE USED WITH HEAVY RENOVATION

NORTH- FIRST FLOOR

World Language

- Small group instruction space
- Resource room
- New walls, flooring, ceiling, openings, electrical and mechanical modifications
- New Furniture

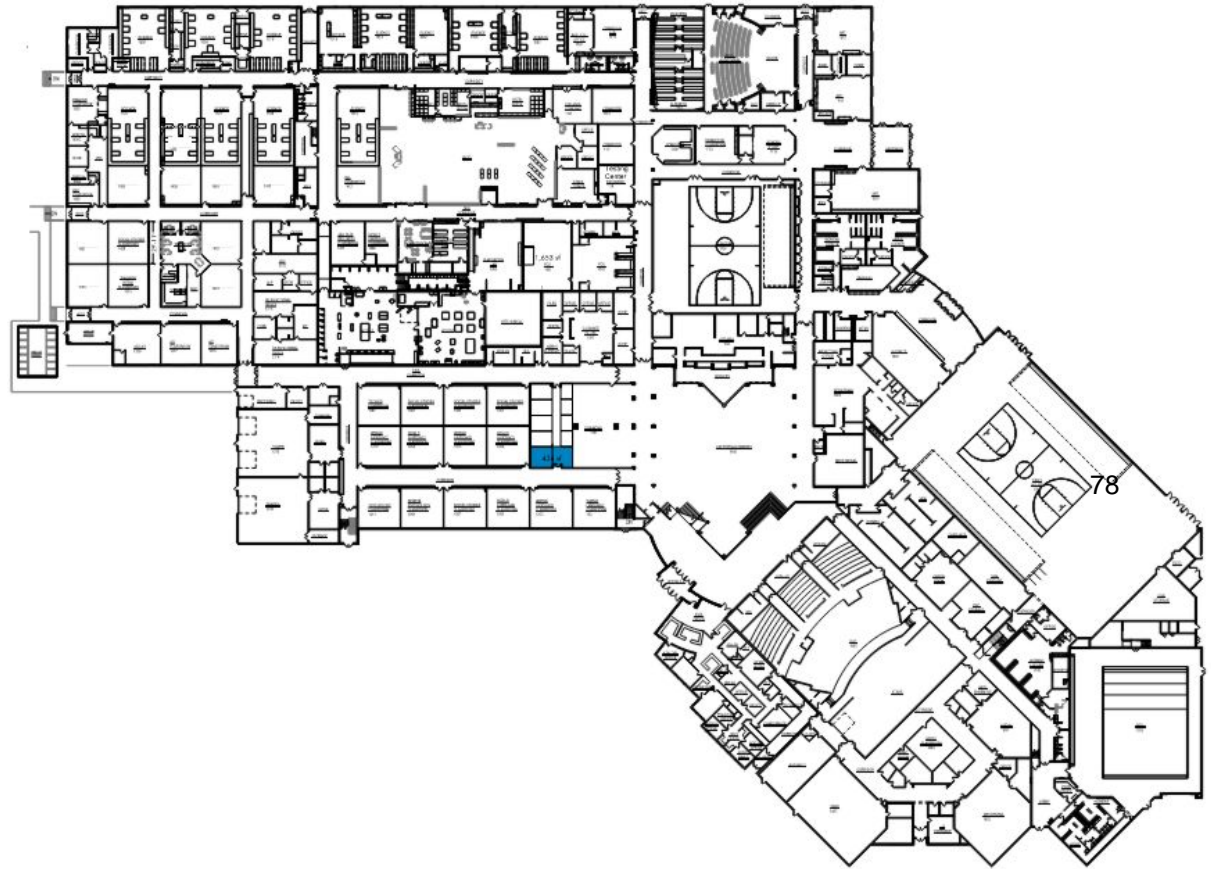

-  SPACE TO BE USED, NO WORK NEEDED
-  SPACE TO BE USED WITH LIGHT RENOVATION
-  SPACE TO BE USED WITH HEAVY RENOVATION

NORTH- FIRST FLOOR

Warrior Media

- Green room and digital lab
- Conditioned room for equipment
- New walls, flooring, ceiling, openings, electrical and mechanical modifications
- New Furniture

-  SPACE TO BE USED, NO WORK NEEDED
-  SPACE TO BE USED WITH LIGHT RENOVATION
-  SPACE TO BE USED WITH HEAVY RENOVATION

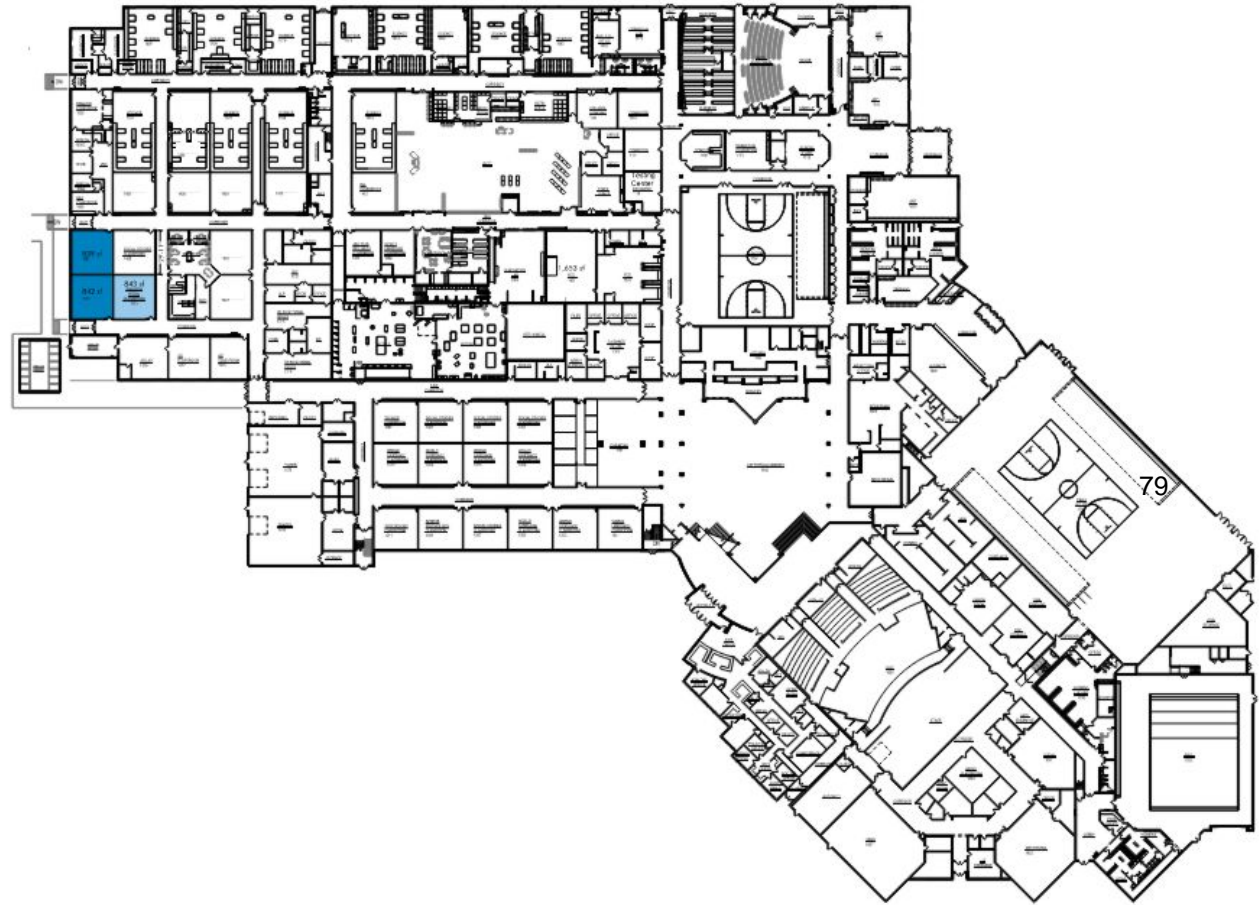

NORTH- FIRST FLOOR

Science

- An additional Life Sciences lab and lecture classroom
- Demolition of existing wall
- New walls, flooring, ceiling, openings, plumbing, electrical and mechanical modifications

-  SPACE TO BE USED, NO WORK NEEDED
-  SPACE TO BE USED WITH LIGHT RENOVATION
-  SPACE TO BE USED WITH HEAVY RENOVATION

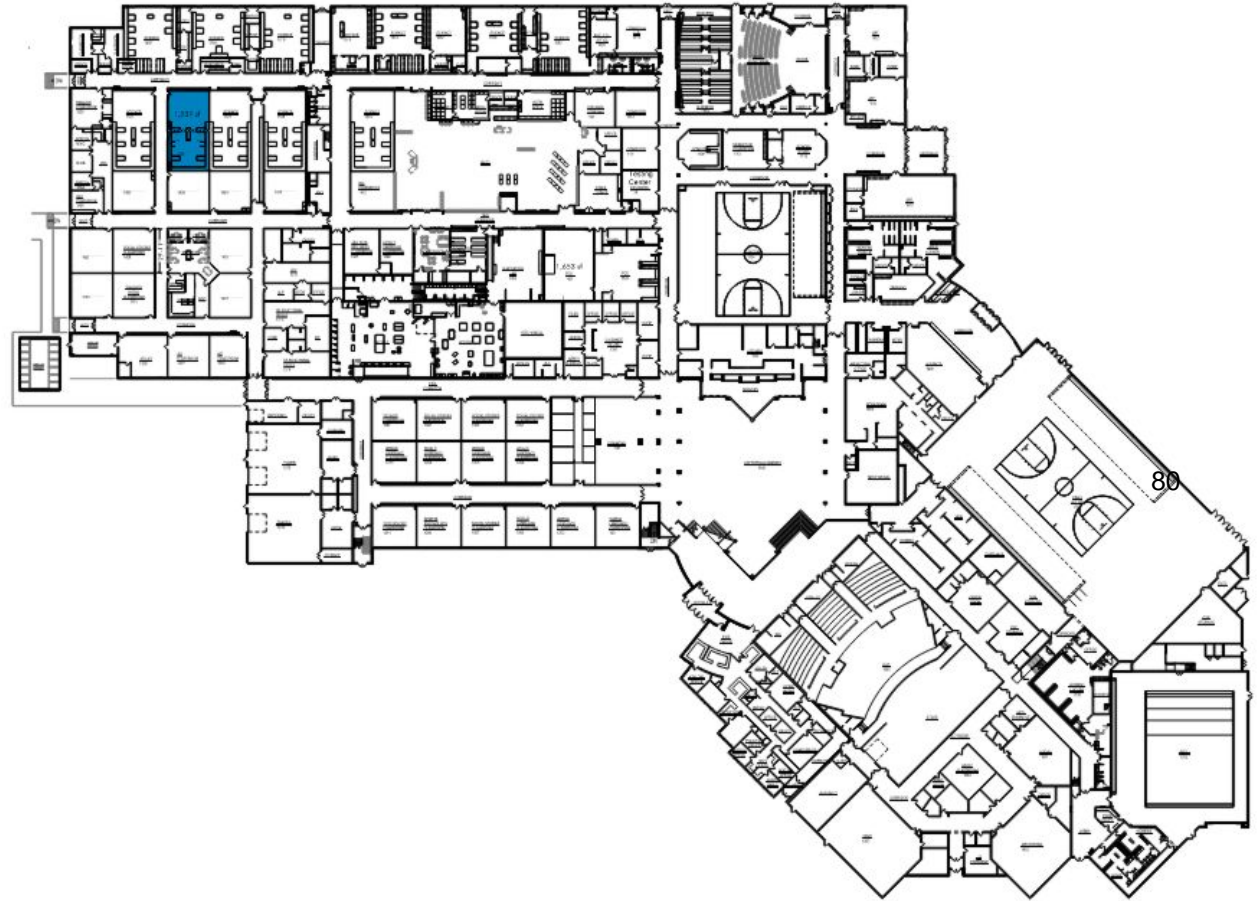

NORTH- FIRST FLOOR

Math

- 2 small group instruction spaces
- New walls, flooring, ceiling, openings, electrical and mechanical modifications
- New Furniture

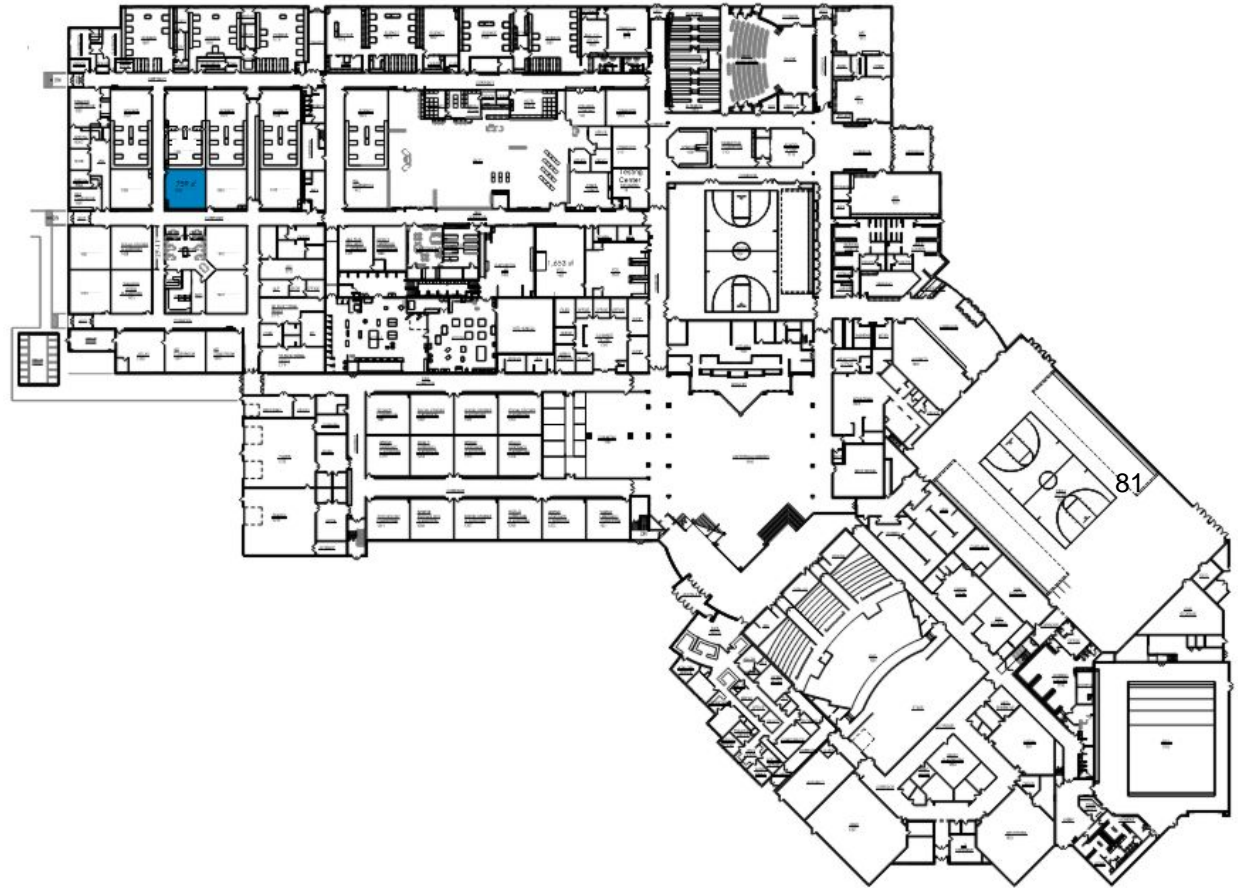

NORTH- FIRST FLOOR

-  SPACE TO BE USED, NO WORK NEEDED
-  SPACE TO BE USED WITH LIGHT RENOVATION
-  SPACE TO BE USED WITH HEAVY RENOVATION

LGA

- 2 large group assembly spaces
 - Meeting rooms for 40+ people with flexible furniture and presentation capabilities
- New walls, flooring, ceiling, openings, electrical and mechanical modifications
- New furniture

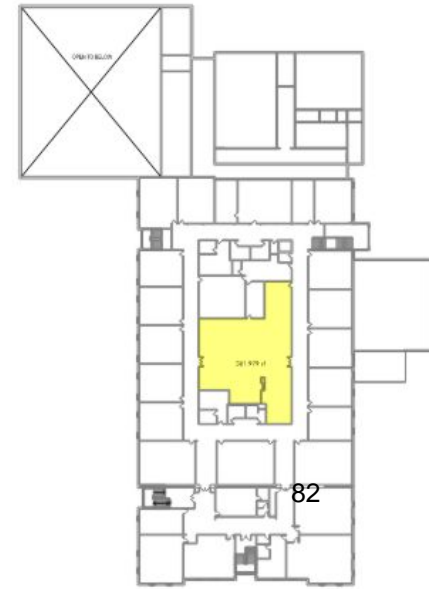

SOUTH - SECOND FLOOR

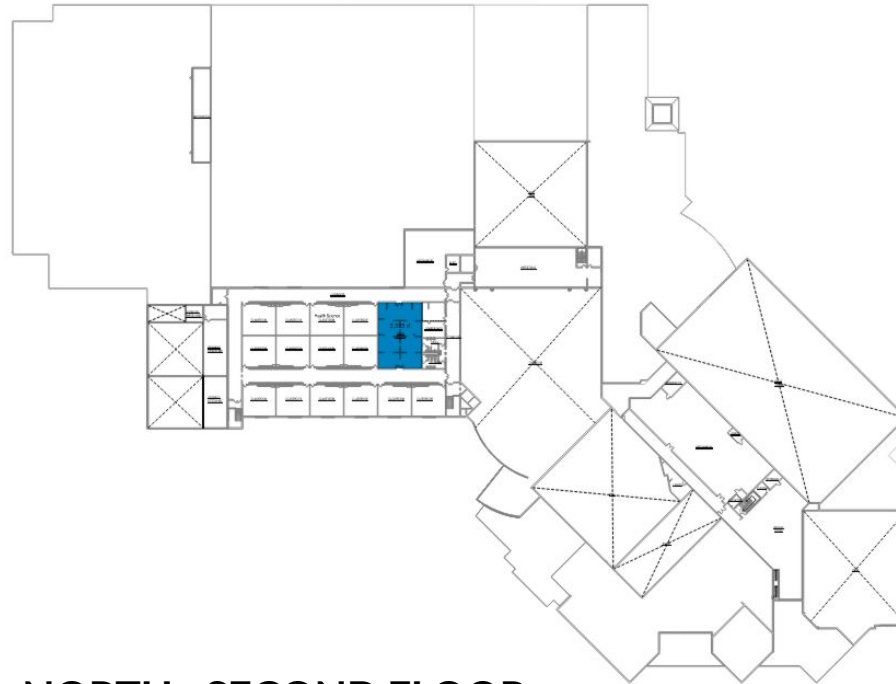

NORTH - SECOND FLOOR

-  SPACE TO BE USED, NO WORK NEEDED
-  SPACE TO BE USED WITH LIGHT RENOVATION
-  SPACE TO BE USED WITH HEAVY RENOVATION

CONFERENCE ROOMS

- Additional conference room space for medium and large groups (10-20 people)
- New walls, flooring, ceiling, openings, electrical and mechanical modifications
- New furniture

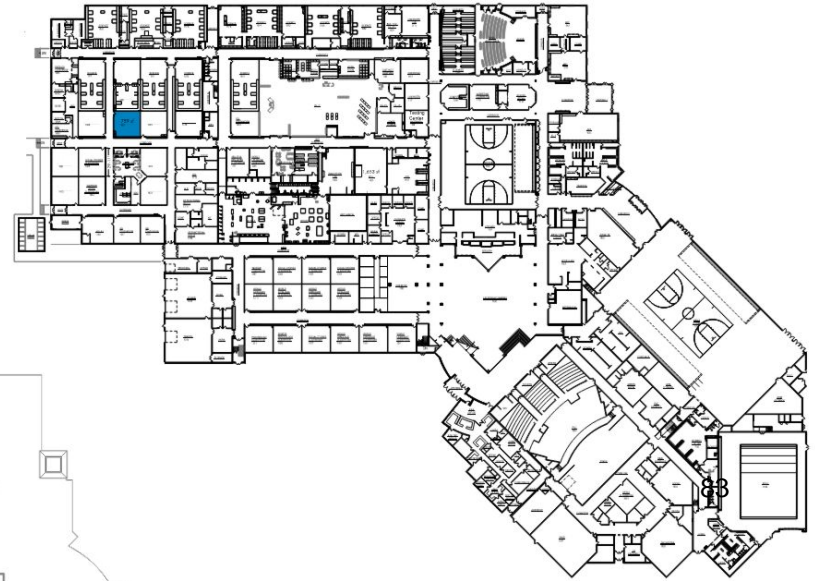

NORTH - SECOND FLOOR

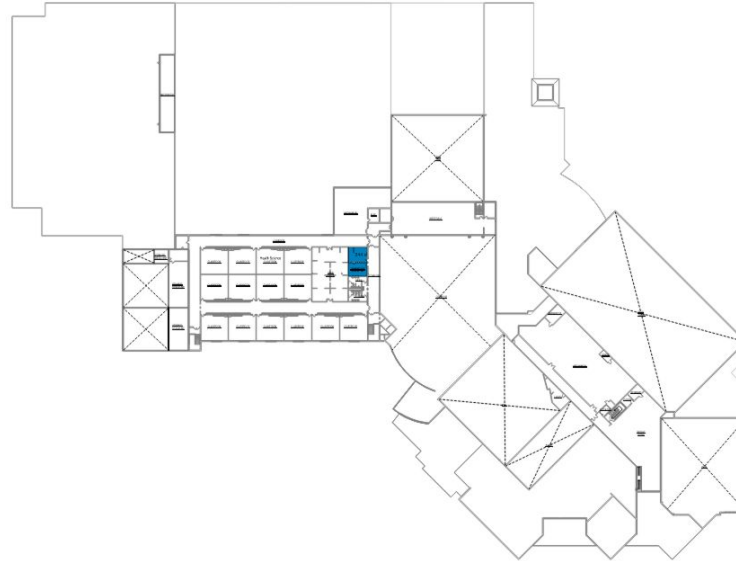

NORTH - FIRST FLOOR

-  SPACE TO BE USED, NO WORK NEEDED
-  SPACE TO BE USED WITH LIGHT RENOVATION
-  SPACE TO BE USED WITH HEAVY RENOVATION

Facilities Maintenance Storage

- Storage building for maintenance equipment located near athletic fields
- 40'x80' new construction of shed type space
- Mechanical, Electrical and Plumbing for 4 seasons.

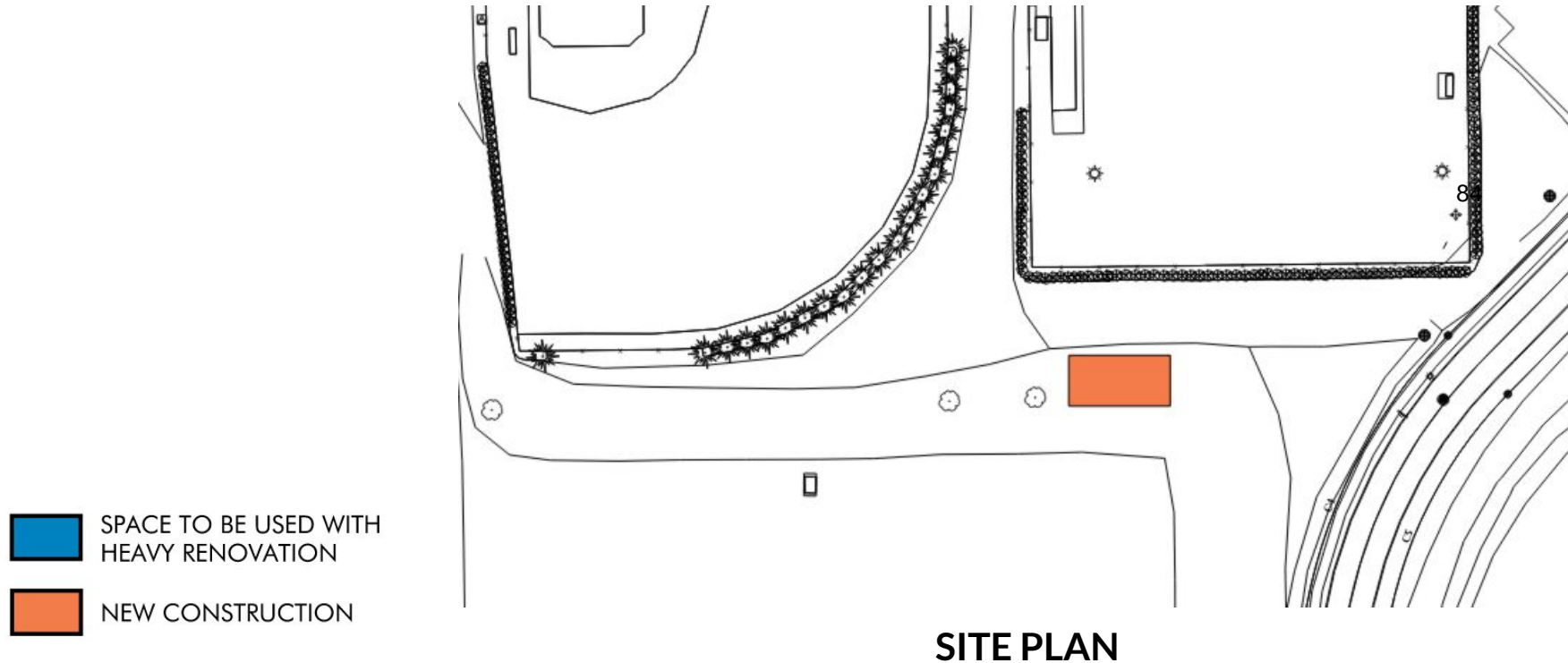

Schedule and Time Frame-Needs Assessment and Prioritization

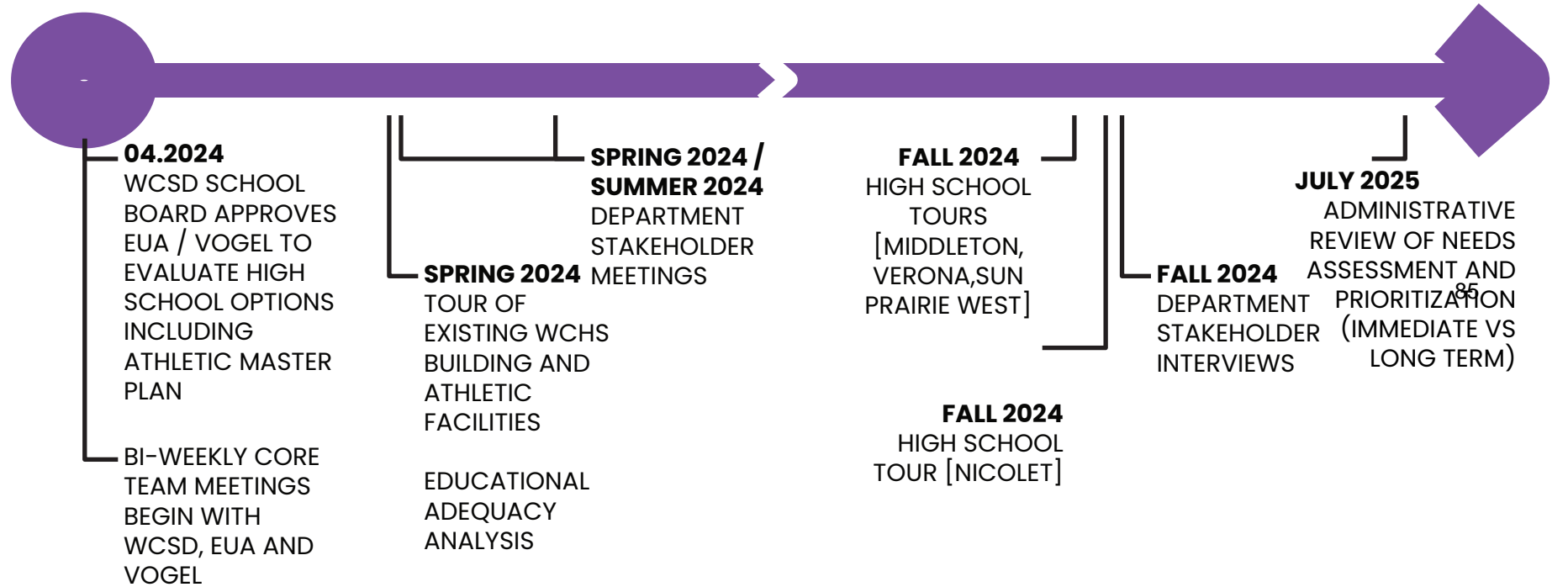

Schedule and Time Frame-Needs Assessment and Prioritization

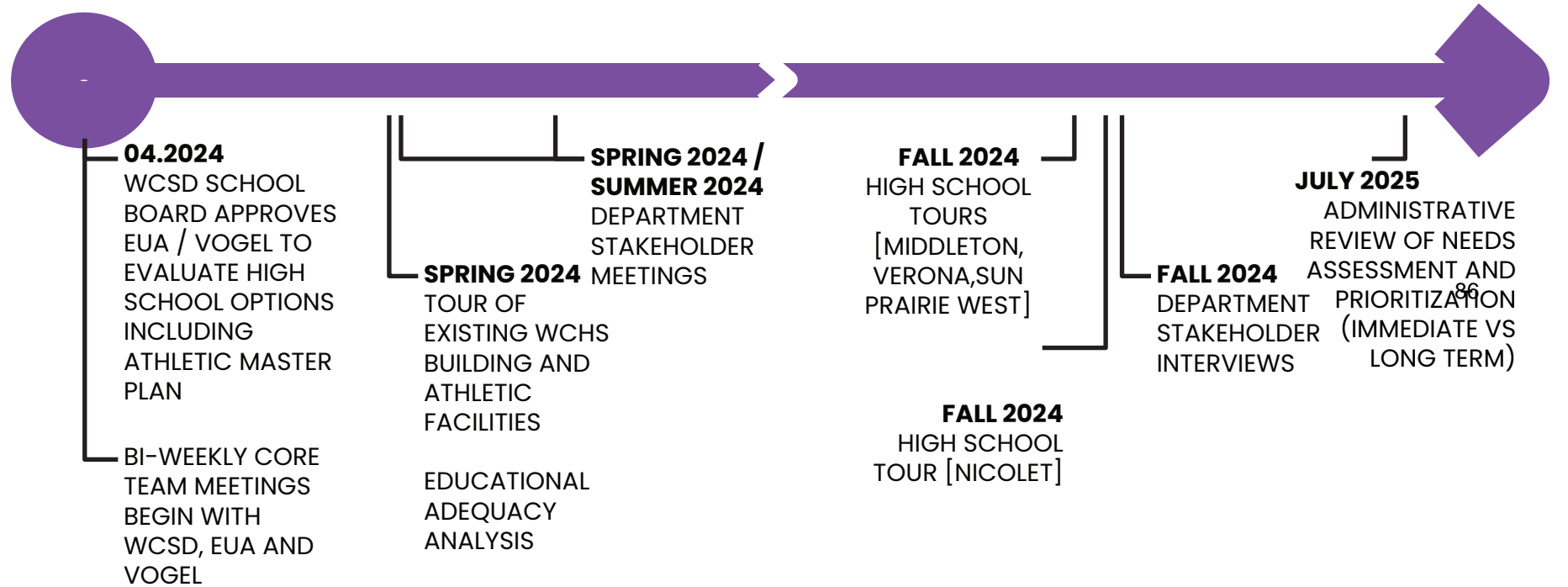

2025-2026 Budget Status Report - October 31, 2025

GENERAL FUND 10 EXPENSES

	Original Budget	Revised Budget	Spent	Ordered	% Spent/Or.	Available
Salary & Benefits (no grants)						
Personnel Costs: Salaries	38,243,560	38,243,560	9,979,894.17	27,031,915.28	96.78%	1,231,750.55
Personnel Costs: Benefits	13,039,606	13,039,606	3,445,550.76	9,410,721.41	98.59%	183,333.83
Total	51,283,166	51,283,166	13,425,444.93	36,442,636.69	97.24%	1,415,084.38

	Budget	Revised Budget	Spent	Ordered	% Spent/Or.	Available
Buildings						
Prairie School	87,510	87,510	45,033.05	5,573.69	57.83%	36,903.26
Prairie School CSF	41,522	41,522	14,881.36	7,306.57	53.44%	19,334.07
Heritage School	88,170	88,170	45,818.49	18,016.47	72.40%	24,335.04
Heritage School CSF	41,359	41,359	5,301.59	8,995.90	34.57%	27,061.51
Arboretum School	75,420	75,420	40,689.81	22,811.24	84.20%	11,918.95
Arboretum School CSF	37,697	37,697	10,048.62	4,978.61	39.86%	22,669.77
Intermediate School	160,000	160,000	47,828.15	17,433.49	40.79%	94,738.36
Intermediate School CSF	46,973	46,973	34,512.97	1,484.06	76.63%	10,975.97
Middle School	153,340	153,340	49,333.24	13,745.71	41.14%	90,261.05
Middle School CSF	47,055	47,055	10,174.30	4,800.52	31.82%	32,080.18
High School	586,365	586,365	120,937.66	142,234.64	44.88%	323,192.70
High School CSF	74,069	74,069	43,763.78	649.14	59.96%	29,656.08
Athletics	447,602	447,602	130,855.22	154,350.30	63.72%	162,396.48

Departments						
Utilities	1,083,269	1,083,269	382,297.22	671,988.11	97.32%	28,983.67
Maintenance	731,990	731,990	279,321.37	352,078.66	86.26%	100,589.97
Contingency Fund	200,000	200,000	0.00	0.00	0.00%	200,000.00
Transportation	1,724,075	1,724,075	363,054.01	1,183,700.14	89.72%	177,320.85
Technology	718,729	718,729	704,847.83	3,903.00	98.61%	9,978.17
Curriculum-Secondary	576,861	576,861	421,863.73	1,946.26	73.47%	153,051.01
Curriculum-Elementary Operatic	455,382	455,382	303,635.77	46,402.84	76.87%	105,343.39
4K District	809,900	809,900	202,377.22	595,670.47	98.54%	11,852.31
Human Resources	54,550	54,550	28,414.07	856.88	53.66%	25,279.05
Superintendent	142,208	142,208	55,452.44	43,070.97	69.28%	43,684.59
Student Services-Operations	93,500	93,500	27,446.25	2,493.40	32.02%	63,560.35
Student Services-District	110,000	110,000	16,119.29	62,594.71	71.56%	31,286.00
Business Office	566,433	566,433	277,576.54	313,482.00	104.35%	-24,625.54
District Wide	2,137,748	2,137,748	771,659.43	26,403.03	37.33%	1,339,685.54
Special Projects	0	0	9,512.50	0.00	#DIV/0!	-9,512.50
Summer School	109,515	109,515	103,753.31	0.00	94.74%	5,761.69

Grants-Fund 10						
Common School Fund-District	7,069	7,069	7,330.32	0.00	103.70%	-261.32
Title 1 Grant (Public)	95,100	95,100	19,014.99	70,858.64	94.50%	5,226.37

Title 1 Grant (Private)	2,700	2,700	0.00	0.00	0.00%	2,700.00
Title 2 Grant (Public)	45,255	45,255	10,032.94	35,115.47	99.76%	106.59
Title 2 Grant (Private)	6,797	6,797	0.00	0.00	0.00%	6,797.00
Title 3 Grant	17,204	17,204	7,824.47	4,740.50	73.04%	4,639.03
Title 4A Grant (Public)	8,672	8,672	8,671.98	0.00	100.00%	0.02
Title 4A Grant (Private)	1,328	1,328	0.00	0.00	0.00%	1,328.00
Career/Tech Ed Grant	58,704	58,704	16,915.28	0.00	28.81%	41,788.72
CEIS Federal Flo-Through	191,600	191,600	42,319.83	0.00	22.09%	149,280.17
Ed. Effectiveness Grant	33,442	33,442	9,950.70	0.00	29.76%	23,491.30
Peer Mentor Grant	12,121	12,121	3,510.00	0.00	28.96%	8,611.00
Perkins Grant	20,049	20,049	13,846.13	0.00	69.06%	6,202.87
School-Based Mental Health	0	0	56,507.44	69,525.00	#DIV/0!	-126,032.44
SAODA	25,000	25,000	0.00	0.00	0.00%	25,000.00
Youth Apprenticeship Grant	88,825	88,825	17,313.00	23,819.99	46.31%	47,692.01

Other Program Totals						
Transfer to Fund 27	7,594,427	7,594,427	0.00	0.00	0.00%	7,594,427.00
Wellness Clinic	300,000	300,000	118,685.03	205,827.41	108.17%	-24,512.44

Subtotals	Original Budget	Revised Budget	Spent	Ordered	% Spent/Or.	Available
Salary & Benefits Totals	51,283,166	51,283,166	13,425,444.93	36,442,636.69	97.24%	1,415,084.38
Building Totals	1,887,082	1,887,082	599,178.24	402,380.34	53.07%	885,523.42
Department Totals	9,514,160	9,514,160	3,947,330.98	3,304,590.47	76.22%	2,262,238.55
Grant Totals	613,866	613,866	213,237.08	204,059.60	67.98%	196,569.32
Other Program Totals	7,894,427	7,894,427	118,685.03	205,827.41	4.11%	7,569,914.56
Total Fund 10 Expenditures	71,192,701	71,192,701	18,303,876.26	40,559,494.51	82.68%	12,329,330.23

GENERAL FUND 10 REVENUES

Building/Department	Original Budget	Revised Budget	Received	Ordered	% Received	Unreceived
Prairie School	2,550	2,550	2,483.14	0.00	97.38%	66.86
Heritage School	2,250	2,250	1,878.20	0.00	83.48%	371.80
Arboretum School	5,820	5,820	6,300.79	0.00	108.26%	-480.79
Intermediate School	37,900	37,900	5,320.99	0.00	14.04%	32,579.01
Middle School	23,700	23,700	19,087.14	0.00	80.54%	4,612.86
High School	199,215	199,215	148,174.66	0.00	74.38%	51,040.34
Curriculum - Elementary	0	0	0.00	0.00	#DIV/0!	0.00
Curriculum - Secondary	10,815	10,815	5,611.79	0.00	51.89%	5,203.21
Maintenance	15,000	15,000	1,111.50	0.00	7.41%	13,888.50
Athletic Dept	71,000	71,000	56,244.09	0.00	79.22%	14,755.91
Human Resources	0	0	0.00	0.00	---%	0.00
Technology	4,200	4,200	973.00	0.00	23.17%	3,227.00
District	69,787,210	69,787,210	5,299,400.66	0.00	7.59%	64,487,809.34

Grants - Fund 10						
Common School Fund-District	296,005	296,005	0.00	0.00	0.00%	296,005.00
Title 1 Grant (Public)	95,100	95,100	0.00	0.00	0.00%	95,100.00

Title 1 Grant (Private)	2,700	2,700	0.00	0.00	0.00%	2,700.00				
Title 2 Grant (Public)	45,255	45,255	0.00	0.00	0.00%	45,255.00				
Title 2 Grant (Private)	6,797	6,797	0.00	0.00	0.00%	6,797.00				
Title 3 Grant	17,204	17,204	0.00	0.00	0.00%	17,204.00				
Title 4A Grant (Public)	8,672	8,672	0.00	0.00	0.00%	8,672.00				
Title 4A Grant (Private)	1,328	1,328	0.00	0.00	0.00%	1,328.00				
Career/Tech Ed Grant	58,704	58,704	0.00	0.00	0.00%	58,704.00				
CEIS Federal Flo-Through	191,600	191,600	0.00	0.00	0.00%	191,600.00				
Ed. Effectiveness Grant	33,442	33,442	0.00	0.00	0.00%	33,442.00				
Peer Mentor Grant	12,121	12,121	0.00	0.00	---	12,121.00				
Perkins Grant	20,049	20,049	0.00	0.00	0.00%	20,049.00				
School-Based Mental Health	130,239	130,239	0.00	0.00	---	130,239.00				
SAODA	25,000	25,000	610.15	0.00	---	24,389.85				
Youth Apprenticeship Grant	88,825	88,825	0.00	0.00	---	88,825.00				
Total Fund 10 Revenues	71,192,701	71,192,701	5,547,196.11	0.00	7.79%	65,645,504.89				

SPECIAL EDUCATION FUND 27 EXPENSES

Salaries & Benefits (no grants)	Budget	Revised Budget	Spent	Ordered	% Spent/Or.	Available
Salaries & Benefits	12,391,381	12,391,381	2,698,981.14	9,362,164.87	97.33%	330,234.99
Departments						
Special Ed-Operations	63,546	63,546	15,599.85	4,153.00	31.08%	43,793.15
Special Ed-District	237,000	237,000	34,628.98	108,370.04	60.34%	94,000.98
Transportation	157,500	157,500	27,186.99	172,813.17	126.98%	-42,500.16
Medicaid	10,000	10,000	11,389.53	0.00	113.90%	-1,389.53
Grants-Fund 27						
IDEA FlowThrough Grant	975,048	975,048	327,208.71	449,697.02	79.68%	198,142.27
IDEA PreSchool Grant	58,500	58,500	5,160.62	3,180.07	14.26%	50,159.31
Total Fund 27 Expenditures	13,892,975	13,892,975	3,120,155.82	10,100,378.17	95.16%	672,441.01

SPECIAL EDUCATION FUND 27 REVENUES

Source	Budget	Revised Budget	Received	Ordered	% Received	Unreceived
IDEA FlowThrough Grant	975,048	975,048	0.00	0.00	0.00%	975,048.00
IDEA PreSchool Grant	58,500	58,500	0.00	0.00	---	58,500.00
Special Ed Revenues	0	0	0.00	0.00	---	0.00
Aid-Sp Ed Transition Grant BBL	15,000	15,000	0.00	0.00	---	15,000.00
Other Fund 27 Revenues	12,844,427	12,844,427	0.00	0.00	0.00%	12,844,427.00
Total Fund 27 Revenues	13,892,975	13,892,975	0.00	0.00	0.00%	13,892,975.00

FOOD SERVICE FUND 50 EXPENSES						
Function	Budget	Revised Budget	Spent	Ordered	% Spent/Or.	Available
All	2,785,330	2,785,330	141,860.14	2,672,256.51	101.03%	-28,786.65
FOOD SERVICE FUND 50 REVENUES						
Source	Budget	Revised Budget	Received	Ordered	% Received	Unreceived
All	2,791,696	2,791,696	426,180.52	0.00	15.27%	2,365,515.48

CALCULATION OF BUILDING/DEPARTMENT BUDGET BALANCES October 31st, 2025

Building/Department	24-25 Carryover	25-26 Revenue Budget	25-26 Rec'd	25-26 Revenue Balance	25-26 Expense Budget	25-26 Spent / Encumbered	25-26 Expense Balance	25-26 Balance	Funds Available
Prairie School	47,635.60	2,550.00	2,483.14	66.86	87,510	50,606.74	36,903.26	36,836.40	84,472.00
Heritage School	23,346.94	2,250.00	1,878.20	371.80	88,170	63,834.96	24,335.04	23,963.24	47,310.18
Arboretum School	16,124.10	5,820.00	6,300.79	-480.79	75,420	63,501.05	11,918.95	12,399.74	28,523.84
Intermediate School	81,096.63	37,900.00	5,320.99	32,579.01	160,000	65,261.64	94,738.36	62,159.35	143,255.98
Middle School	73,627.64	23,700.00	19,087.14	4,612.86	153,340	63,078.95	90,261.05	85,648.19	159,275.83
High School	95,339.58	199,215.00	148,174.66	51,040.34	586,365	263,172.30	323,192.70	272,152.36	367,491.94
Athletic Dept	49,511.14	71,000.00	56,244.09	14,755.91	447,602	285,205.52	162,396.48	147,640.57	197,151.71
Curriculum-Elementary	33,934.06	0.00	0.00	0.00	455,382	350,038.61	105,343.39	105,343.39	139,277.45
Curriculum-Secondary	32,163.75	10,815.00	5,611.79	5,203.21	576,861	423,809.99	153,051.01	147,847.80	180,011.55
CTE Grant	114,986.26	58,704.00	0.00	58,704.00	58,704	16,915.28	41,788.72	-16,915.28	98,070.98
Human Resources	15,480.06	0.00	0.00	0.00	54,550	29,270.95	25,279.05	25,279.05	40,759.11
Maintenance	183,424.06	15,000.00	1,111.50	13,888.50	731,990	631,400.03	100,589.97	86,701.47	270,125.53
Special Education	28,375.10	0.00	0.00	0.00	63,546	19,752.85	43,793.15	43,793.15	72,168.25
Student Services	147,461.64	0.00	0.00	0.00	93,500	29,939.65	63,560.35	63,560.35	211,021.99
Superintendent	854.92	0.00	0.00	0.00	142,208	98,523.41	43,684.59	43,684.59	44,539.51
Technology	22,162.76	4,200.00	973.00	0.00	718,729	708,750.83	9,978.17	9,978.17	32,140.93
4K	19,772.05	0.00	0.00	0.00	809,900	798,047.69	11,852.31	11,852.31	31,624.36
	985,296.29							1,161,924.85	2,147,221.14



WAUNAKEE

COMMUNITY HIGH SCHOOL

301 Community Drive
Waunakee, Wisconsin 53597
(608) 849-2100

October 27, 2025

TO: Dr. Monica Kelsey-Brown
Board of Education

FROM: Brian Borowski

RE: **Donation: 2007 Chevy Trailblazer**
Jeremy and Sarah Alsaker
1100 Turnberry Court
Waunakee, WI 53597

On behalf of Mr. Cole Scott, Technology & Engineering Instructor, I am requesting your permission to accept the donation listed below. The item details are included for your reference.

- **2007 Chevy Trailblazer**
- **Approximate value of \$4,000**
- VIN: 1GNDT13S772200794
- 116,000 Miles
- The vehicle is in good condition, minor dents and scratches to body panels, some frame rust, only known mechanical issue is leaking transmission.

This donation would be a valuable addition to the Waunakee High School shop, enhancing our program by providing more opportunities for hands-on learning and practical application of coursework.

Mr. Scott and I are grateful for the Alsaker family and their donation and we hope you will consider this opportunity.

Thank you.



WAUNAKEE

COMMUNITY SCHOOL DISTRICT

ADMINISTRATION OFFICE

905 Bethel Circle
Waunakee, Wisconsin 53597
(608) 849-2000

Superintendent's Office

10/30/25

Memo To: WCSD Board of Education

From: Dr. Monica Kelsey-Brown

Re: Ted and Jan Tweed Charitable Fund

Janet Tweed, 1010 S. Holiday Dr. Waunakee, WI 53597, made a donation of \$20,000.00 to WCSD to be used for the high school and middle school music program.