

Regular Meeting
Tuesday, May 19, 2026 7:00 PM

Harleton Independent School District
17000 S.H. 154
Harleton, Texas 75651

Agenda

1. Call to Order
2. Roll Call of Board Members

3. Pledge of Allegiance and Invocation
4. Student of the Month
5. Open Forum
6. Consent Agenda
 - 6.A. Approval of Board Minutes
 - 6.B. Donations
 - 6.C. Obligations and Vouchers

 - 6.D. Financial Statement

7. Discussion Item
 - 7.A. Report of our Safety and Security Audit conducted by Region 7
 - 7.B. Discuss Outdoor AG Education Class Enclosure
8. Action Items
 - 8.A. Consider/Take Action on Delegating Hiring Authority to the Superintendent for Professional Staff, from May 20, 2026, to September 4, 2026
 - 8.B. Consider/Take Action on Field Trips
 - 8.C. Consider/Take Action on adopting a resolution that approves the determination that the District's budget is not currently sufficient to retrofit all buses with 3-point seat belts, as required by SB 546.
 - 8.D. Consider/Take Action on Purchase of Ovens for Cafeteria
 - 8.E. Consider/Take Action on Hiring a High School Science Teacher
 - 8.F. Consider/Take Action on Hiring an Elementary Dyslexia Interventionist Teacher
 - 8.G. Consider/Take Action on Hiring an Elementary Fourth Grade Math Teacher
 - 8.H. Consider/Take Action on Hiring a High School Social Studies/Coach Teacher
 - 8.I. Consider/Take Action on Hiring Head Start Teacher
 - 8.J. Consider/Take Action on Board Resolution Extending Depository Contract for Funds of Independent School Districts
9. Closed Session
 - 9.A. Pursuant to Texas Government Code Sections 551.074 for the purpose of considering the appointment, employment, evaluation, reassignment, duties, discipline, or dismissal of a public officer or employee and 551.072 Deliberations about Real Property - A governmental body may conduct a closed meeting to deliberate the purchase, exchange, lease, or value of real property is deliberation in

an open meeting would have a detrimental effect on the position of the governmental body in negotiations with a third person.

10. Superintendent Report
 - 10.A. Current Enrollment
 - 10.B. Resignations and New Hires
11. Adjourn

Harleton ISD

Regular Meeting: April 14, 2026

Members Present: Kevin Evers
Harvey Fox
Pat Mc Gill
Ben Wilson
Brian Fitzgerald
Jacob Muehlstein

Members Absent: Tim Skaggs

The meeting was called to order at 7:00 PM with a roll call of members.

Pledge was led by Jacob Muehlstein and invocation was offered by Jay Ratcliff.

Students of the Month were recognized and presented a certificate and a gift card. Elementary students of the month for April were Leslie Rodriguez and Case Galloway. Junior High student of the month for April was Lillian Smith. High School student of the month for April will be recognized next month.

Open Forum was not held.

The consent agenda was approved by general consent which consisted of:

- March 10, 2026 Board Minutes
- Obligations and Vouchers
- Financial Statement

Motion by Ben Wilson and second by Kevin Evers to approve Field Trips as presented. Voting for: Harvey Fox, Jacob Muehlstein, Brian Fitzgerald, and Pat Mc Gill. Voting against: None. Motion carried.

Motion by Ben Wilson and second by Brian Fitzgerald to approve Annotated List of Books for Library Purchase as presented. Voting for: Jacob Muehlstein, Harvey Fox, Pat Mc Gill and Kevin Evers. Voting against: None. Motion carried.

Motion by Harvey Fox and second by Ben Wilson to approve Bid for Finishing Floors on all campuses as presented. Voting for: Kevin Evers, Jacob Muehlstein, Pat Mc Gill and Brian Fitzgerald. Voting against: None. Motion carried.

Motion by Brian Fitzgerald and second by Ben Wilson to approve Student Insurance for the 2026-2027 School Year as presented. Voting for: Harvey Fox, Jacob Muehlstein, Pat Mc Gill and Kevin Evers. Voting against: None. Motion carried.

Motion by Harvey Fox and second by Kevin Evers to approve hiring Kenneth Buckner as High School Algebra I teacher as presented. Voting for: Ben Wilson, Jacob Muehlstein, Pat Mc Gill and Brian Fitzgerald. Voting against: None. Motion carried.

Motion by Harvey Fox and second by Ben Wilson to approve hiring Madison Ratcliff as High School Floral Design, AG Mechanics and Welding Teacher as presented. Voting for: Brian Fitzgerald, Jacob Muehlstein, Pat Mc Gill and Kevin Evers. Voting against: None. Motion carried.

The Board of trustees convened into Closed Session at 7:33 PM, pursuant to Texas Government Code Sections 551.074 for the purpose of considering the appointment, employment, evaluation, reassignment, duties, discipline, or dismissal of a public officer or employee and 551.076 Safety and Security.

Superintendent Report

- Enrollment
- Resignations/New Hires
- Discuss Projects and Facility Maintenance
- Invitation – Junior High Awards Ceremony
- Senior Timeline

The Board of trustees reconvened at 7:48 PM.

Motion by Ben Wilson and second by Kevin Evers to adjourn meeting at 7:49 PM. Voting for: Harvey Fox, Pat Mc Gill, Jacob Muehlstein and Brian Fitzgerald. Voting against: None. Motion carried.

Jacob Muehlstein, President

Harvey Fox, Secretary

Harleton ISD Donations

DONATION	ORGANIZATION	DATE GIVEN	VALUE	TAX DEDUCTIBLE
Sports Banquet Donations	General Fund	5/5/2025	\$737.00	
Theatre Community Show	OAP Theatre Fund	2/26/2026	\$346.00	

For the Month of April

Check Nbr	Trans Date	Payee	PO Nbr	Invoice Nbr	Fnd-Fnc-Obj.So-Org-Prog	Reason	Amount	EFT
		Carmela's Magical Venue	061221	1234	865-00-2190.HS-001-6000HQ	PROM Venue	500.00	N
		Redwater ISD- Athletics	061213	UIL OAP Clinic	865-00-2190.HS-001-6000HO	Final OAP Clinic	300.00	N
		Area VI FFA Assoc	060799	FFA Fees	865-00-2190.HS-001-6000H3	Texas ffa roster	1,411.00	N
010744	04-07-2026	Fresh Country Food Servic	061596	137090&137323	865-00-2190.HS-001-6000H3	fresh country fundraiser FFA	545.60	N
010745	04-07-2026	Amazon Capital Services	061672	19fhxxrcdyf	865-00-2190.JH-041-6000J3	JH Cheer fundraiser	148.80	N
010746	04-10-2026	Twisted Lines Apparel LLC	061470	0007157	865-00-2190.EL-101-6000E4	Archery jerseys	1,200.00	N
010747	04-14-2026	Varsity Spirit Fashion & Su	061640	24704841	865-00-2190.JH-041-6000J3	JH Pom Pom Order	530.00	N
010748	04-16-2026	Christi Siler	061811	reimbursement	865-00-2190.HS-001-6000HB	Reimb HS Cheer Supplies	241.25	N
010749	04-16-2026	Longview World of	061575	2nd Field Trip	865-00-2190.EL-101-6000E2	2nd grade field trip on 4/30	385.00	N
010750	04-16-2026	Jason A& Teresa C Bonne	061458	Kinder Trip	865-00-2190.EL-101-6000E2	Kinder Field Trip on 4/24/26	392.00	N
010751	04-16-2026	Two Aunts Investment	061810	rvbarv430yx3p	865-00-2190.EL-101-6000E2	1st grade field trip on 4/22	294.00	N
010752	04-16-2026	East Texas Oil Museum -	061789	25984	865-00-2190.EL-101-6000E2	3rd grade field trip on 5/1	350.00	N
010753	04-16-2026	Historic Jefferson Foundati	061426	4th field trip	865-00-2190.EL-101-6000E2	4th grade field trip on 5/1/26	270.00	N
010754	04-17-2026	Walkers Mill Vineyard LLC	061840	#2026	865-00-2190.HS-001-6000HQ	Prom Venue Rental	1,000.00	N
010755	04-21-2026	Marla Jones	061816	001950	865-00-2190.JH-041-6000J3	JH Cheer Camp shirts	434.00	N
010757	04-23-2026	Heather Knopp	061858	meal money	865-00-2190.HS-001-6000HO	Meal Money Thespian Contest	828.00	N
010758	04-24-2026	Phillip Haskell	061848	prom security	865-00-2190.HS-001-6000HQ	PROM SECURITY	200.00	N
050143	04-28-2026	Credit Card Center	061330	6f7236d9-0007	199-11-6299.00-001-611000	Snipe-IT Yearly Renewal	111.19	N
			061330	6f7236d9-0007	199-11-6299.00-041-611000	Snipe-IT Yearly Renewal	98.80	N
			061330	6f7236d9-0007	199-11-6299.00-101-611000	Snipe-IT Yearly Renewal	190.00	N
			061424	appr#095758	199-11-6399.00-101-611000	Supplies from Sam's	91.89	N
			061620	or#1229362	199-11-6399.12-001-611000	Tech Tools	36.97	N
			061620	or#1229362	199-11-6399.12-041-611000	Tech Tools	36.97	N
			061620	or#1229362	199-11-6399.12-101-611000	Tech Tools	36.97	N
			061586	staff lunch	199-11-6411.00-001-611000	HS Staff meal	273.62	N
			061485	or#80000002203	199-23-6399.00-041-699000	Office supplies - paper goods	151.52	N
			061477	or#10400791112	199-31-6339.00-041-622000	Snacks STAAR Test Season	72.00	N
			061477	or#10400791112	199-31-6339.00-041-699000	Snacks STAAR Test Season	100.78	N
			061501	or#80444	199-36-6399.01-001-691000	Bsb Medical-The Perfect Arm	287.50	N
			061508	or# 10181	199-36-6399.11-101-699000	State Reg fees Elem team	720.00	N
			061507	or# 10174	199-36-6399.11-101-699000	State 3D Reg fees HS team	510.00	N
			061506	or# 10178	199-36-6399.11-101-699000	State Tourney Reg Fees HS	510.00	N
			061509	10179	199-36-6399.11-101-699000	State 3D Reg fees Elem team	720.00	N
			061491	auth #039782	199-36-6412.00-999-699000	HS State Competition students	194.15	N
			061413	Hotel Stay	199-36-6412.04-001-691000	Girls Powerlifting Reg Hotels	327.00	N
			061427	Hotel Stay	199-36-6412.04-001-691000	G Pwl State Hotels	1,943.50	N
			061539	mazzio's	199-36-6412.04-001-691000	HS Powerlifting meal	71.63	N
			061432	chk# 101288	199-36-6412.04-001-691000	B Pwl State Hotels	119.75	N
			061588	appr# 039091	199-36-6412.09-001-691000	HS Track food	243.60	N

For the Month of April

Check Nbr	Check Date	Payee	PO Nbr	Invoice Nbr	Fnd-Fnc-Obj.So-Org-Prog	Reason	Amount	EFT
			061656	or#80000273017	199-36-6499.00-041-6990JH	JH staff incentives	199.92	N
			061621	staff incentive	199-36-6499.00-101-6990EL	Elem Staff Incentives	79.96	N
			061582	appr#073449	199-36-6499.00-101-6990EL	Staff luncheon supplies-Sams	200.62	N
			061613	band meal	199-36-6499.05-001-699000	HS Band meal	150.45	N
			061543	auth# 089861	199-36-6499.05-001-699000	HS Student Awards	303.75	N
			061544	superstar meal	199-36-6499.05-001-699000	HS Student Awards	165.90	N
			061486	bd meal	199-41-6411.00-701-699000	Staff meal	195.42	N
			060254	tr#238461	199-41-6419.00-702-699000	Board Meal March	170.91	N
			061333	sam's	199-41-6419.00-702-699000	Central office supplies-Sams	376.65	N
			061487	auth#021818	199-53-6411.00-750-699000	Staff meal	146.31	N
			061488	Trans#2009	199-53-6411.00-750-699000	Staff meal	127.05	N
			061486	bd meal	199-53-6411.00-750-699000	Staff meal	195.42	N
			061585	TASB Webinar	199-53-6499.00-750-699000	TASB Training	150.00	N
			061881	Notary renewal	199-53-6499.00-750-699000	Notary Renewal	10.27	N
						Totals for Check 050143	9,320.47	
050144	04-28-2026	Credit Card Center	061343	appr# 059418	865-00-2190.HS-001-6000HG	Sam's-FH and SB snacks	165.43	N
			061343	appr# 059418	865-00-2190.HS-001-6000HM	Sam's-FH and SB snacks	165.55	N
			061455	or# 20414692	865-00-2190.HS-001-6000HV	HS vending supplies	320.66	N
						Totals for Check 050144	651.64	
050721	04-29-2026	WEX Bank	061135	111588559	199-11-6311.00-001-622000	District Fuel Charges	348.87	N
			061135	111588559	199-34-6311.00-999-699000	District Fuel Charges	1,500.00	N
			061135	111588559	199-51-6311.00-999-699000	District Fuel Charges	700.00	N
						Totals for Check 050721	2,548.87	
081879	04-07-2026	CDW Government	061603	A14619F	199-11-6649.03-001-611000	Monitors for Campus Offices	1,624.00	N
			061603	A14619F	199-11-6649.03-041-611000	Monitors for Campus Offices	295.27	N
			061603	A14619F	199-11-6649.03-101-611000	Monitors for Campus Offices	1,033.45	N
						Totals for Check 081879	2,952.72	
081880	04-07-2026	Coburns	061731	11632465	199-51-6319.02-999-699000	Grounds Equip/ Blower	658.50	N
081881	04-07-2026	Dairy Queen	061328	SB Meal	199-36-6412.08-001-691000	SB meals	90.00	N
081882	04-07-2026	East Tex Filters Of Longvi	061036	605427-326	199-51-6249.00-001-699000	Monthly Filter Service	220.00	N
			061036	605268-326	199-51-6249.00-041-699000	Monthly Filter Service	140.00	N
			061036	605260-326	199-51-6249.00-101-699000	Monthly Filter Service	242.75	N
						Totals for Check 081882	602.75	
081883	04-07-2026	Datamax, Inc.	061027	LG01257021	199-11-6269.00-041-611000	Lease G-01257	1,138.48	N
081884	04-07-2026	Secal Group LLC	060555	279645-00	199-41-6399.01-701-699000	Central Office Chairs	2,673.84	N
081885	04-07-2026	Chance Marett	061716	Bsb Official	199-36-6219.00-001-691000	Bsb Officials	180.00	N
081886	04-07-2026	Anthem Sports LLC	061630	461497	199-36-6399.08-999-691000	Bsb/SB Supplies-Field Drag	571.95	N
081887	04-07-2026	Brothers Produce, Inc.	060204	March 2026	240-35-6341.00-999-699000	MAR '26 PRODUCE	1,170.90	N
081888	04-07-2026	ChromebookParts.com	061627	2771418,278940	199-11-6649.03-101-611000	Chromebook Parts	192.60	N
081889	04-07-2026	Clark Howard	061717	Bsb Official	199-36-6219.00-001-691000	Bsb Officials	195.00	N

For the Month of April

Check Nbr	Check Date	Payee	PO Nbr	Invoice Nbr	Fnd-Fnc-Obj.So-Org-Prog	Reason	Amount	EFT
081890	04-07-2026	Quentin Heath McFall	061680	SRO Duty	199-52-6219.00-999-699000	SRO Duty	360.00	N
081891	04-07-2026	Amazon Capital Services	061646	cameras/ photog	199-11-6399.02-001-622000	Cameras for Photography class	1,303.83	N
081892	04-07-2026	Garrett Bailey	061681	SRO Duty	199-52-6219.00-999-699000	SRO Duty	340.00	N
081893	04-07-2026	Daniel Matthews	061715	Bsb Official	199-36-6219.00-001-691000	Bsb Officials	180.00	N
081894	04-07-2026	Chris Merritt	061725	Bsb Official	199-36-6219.00-001-691000	BSB official	195.00	N
081895	04-08-2026	Flatt Stationers Inc	061651	299473-00	199-11-6399.00-041-6110PA	Copy Paper for JH	940.00	N
081896	04-08-2026	Flowers Baking Co of	060232	March 2026	240-35-6341.00-999-699000	MAR '26 BREAD	1,093.45	N
081897	04-08-2026	Harleton Hardware LLC	061045	March 2026	199-34-6319.00-999-699000	Hardware Supplies	100.00	N
			061045	March 2026	199-51-6319.00-999-699000	Hardware Supplies	908.90	N
Totals for Check 081897							1,008.90	
081898	04-08-2026	Hawkins ISD	061637	5 entries	199-36-6499.01-041-691000	Track Entry Fees for Hawkins	500.00	N
081899	04-08-2026	Heritage Professional Prod	061629	0025584552-001	199-36-6399.08-999-691000	Field Chalk	223.00	N
081900	04-08-2026	Eichelbaum Wardell	061749	97454	199-41-6211.00-701-699000	Legal Fees	34.50	N
081901	04-08-2026	East Texas Council of Go	061751	Harleton-2100 2	199-41-6499.00-720-699000	Annual Membership Dues	50.00	N
081902	04-08-2026	Charlie Downs	061760	Reg golf meal	199-36-6412.04-001-691000	Regional Golf Meals	732.00	N
081903	04-08-2026	Burbank Sport Nets	061617	25223	199-36-6399.02-001-691000	Baseball Supplies	787.00	N
081904	04-08-2026	Bart Bradley	061755	Bsb Official	199-36-6219.00-001-691000	Bsb Officials-UG	105.00	N
081905	04-08-2026	Gecko Pest Control LLC	061086	315468	199-51-6249.04-999-699000	Monthly Pest Control	292.41	N
			061086	315468	240-51-6249.01-999-699000	Monthly Pest Control	87.59	N
Totals for Check 081905							380.00	
081906	04-08-2026	The 6th Floor Museum De	061738	order# 346295	199-11-6412.00-001-611000	HS Forensics Field Trip	272.00	N
081907	04-08-2026	Gold Star Foods- Texas Di	061753	March 2026	240-35-6299.00-999-699000	Commodity Storage/Delivery	1,017.45	N
081908	04-08-2026	Amazon Capital Services	061604	1469pgt9tdvc	199-11-6649.03-001-611000	Speakers and Rack Cover	62.62	N
			061604	1469pgt9tdvc	199-11-6649.03-041-611000	Speakers and Rack Cover	54.64	N
			061604	1469pgt9tdvc	199-11-6649.03-101-611000	Speakers and Rack Cover	111.96	N
Totals for Check 081908							229.22	
081909	04-08-2026	Heather Knopp	061737	OAP Meal money	199-36-6412.00-999-699000	Meal Money - Area	1,152.00	N
081910	04-08-2026	Hawkins Athletic Booster	061638	track meals	199-36-6412.01-041-691000	Meals for boys and girls track	280.00	N
081911	04-08-2026	Hiland Dairy Foods	060223	March 2026	240-35-6341.00-999-699000	MAR '26 MILK	3,398.40	N
081912	04-08-2026	Cherokee Ranch Golf Club	061719	Golf entry fee	199-36-6499.01-001-691000	Boys Regional Golf Tournament	135.00	N
081913	04-08-2026	Amazon Capital Services	061623	1mk47wq1tk1k	199-11-6399.06-101-611000	2nd grade supplies	160.10	N
081914	04-08-2026	Mt Enterprise ISD	061740	District OAP fe	199-36-6412.02-001-699000	Bi-District UIL OAP	812.97	N
081915	04-09-2026	Tombell Copr	060241	155482 & 155489	240-35-6299.00-999-699000	MAR '26 LEASE/SUPPLIES	238.00	N
081916	04-09-2026	Linden-Kildare High Schoo	061635	entry fees	199-36-6499.01-041-691000	Track Entry Fee Linden	400.00	N
081917	04-09-2026	Marshall Welding Supply I	061106	841362	199-11-6269.01-001-611000	Monthly Rental Fee	17.25	N
			061106	841362	199-11-6269.01-001-622000	Monthly Rental Fee	74.75	N
			061106	841362	199-11-6269.01-041-611000	Monthly Rental Fee	17.25	N

For the Month of April

Check Nbr	Check Date	Payee	PO Nbr	Invoice Nbr	Fnd-Fnc-Obj.So-Org-Prog	Reason	Amount	EFT
			061106	841362	199-11-6269.01-101-611000	Monthly Rental Fee	17.25	N
			061106	841362	199-51-6269.00-999-699000	Monthly Rental Fee	17.25	N
						Totals for Check 081917	143.75	
081918	04-09-2026	Melody's Southwest Cons	061772	202654138&024	199-36-6219.03-001-691000	Student Drug Testing	1,519.00	N
081919	04-09-2026	Music Mountain Water Co	061536	March 2026	199-11-6499.01-001-6990HS	Monthly Water Service	68.94	N
			061536	March 2026	199-11-6499.01-041-6990JH	Monthly Water Service	73.38	N
			061536	March 2026	199-11-6499.01-101-6990EL	Monthly Water Service	127.91	N
			061536	March 2026	199-41-6419.00-702-699000	Monthly Water Service	10.93	N
			061536	March 2026	199-51-6411.00-999-699000	Monthly Water Service	20.00	N
						Totals for Check 081919	301.16	
081920	04-09-2026	Pliier International - Longvi	061754	x101039436:01	199-34-6319.00-999-699000	Bus 1 / engine parts	2,842.30	N
081921	04-09-2026	GLG Management West L	061600	HISD03232026	199-11-6412.00-001-623000	Meals for trips	60.61	N
081922	04-09-2026	Pureland Supply LLC	061642	920269	199-11-6649.03-001-611000	Projector Lamps	703.89	N
081923	04-09-2026	Republic Services #070	061118	0070003763377	199-51-6259.05-999-699000	Trash Service/ District	3,129.66	N
081924	04-09-2026	Kane Security Company	061054	36612	199-51-6249.00-001-699000	Monthly Fire Alarm Monitoring	30.00	N
			061055	36557	199-51-6249.00-001-699000	Hardware Supplies	246.42	N
						Totals for Check 081924	276.42	
081925	04-09-2026	Cherokee Ranch Golf Club	061720	Golf entry fee	199-36-6499.01-001-691000	Girs Regional Golf Tournament	700.00	N
081926	04-09-2026	Kerry Strong	061757	reimbursement	199-36-6412.09-001-691000	district track meals	344.40	N
081927	04-09-2026	Picture Perfect Speaker In	061778	2026113	199-41-6219.00-750-699000	Begining of Year Speaker	2,500.00	N
081928	04-09-2026	Harrison Central Appraisal	060905	2nd Quarter	199-99-6213.00-999-699000	Tax Collections / Appraisals	9,995.32	N
081929	04-09-2026	Harrison Central Appraisal	060908	March 2nd quart	199-41-6213.00-703-699000	Tax Collections / Appraisals	1,126.44	N
081930	04-09-2026	Region 7 Education Servic	061632	101647	199-34-6219.00-999-699000	Bus Recertification	60.00	N
			061631	101646	199-34-6219.00-999-699000	Bus Recertification	60.00	N
						Totals for Check 081930	120.00	
081931	04-09-2026	Rick's Sign Company LLC	061729	42322	199-36-6499.03-001-691000	HS Girls Basketball Banners	450.00	N
081932	04-09-2026	Sysco Food Services Of E.	060215	March 2026 2nd	240-35-6341.00-999-699000	MAR '26 GROCERY	7,961.92	N
			060215	March 2026 2nd	240-35-6341.01-999-699000	MAR '26 GROCERY	1,003.47	N
			060215	March 2026 2nd	240-35-6342.00-999-699000	MAR '26 GROCERY	1,325.33	N
						Totals for Check 081932	10,290.72	
081933	04-09-2026	Sabine Athletic Boosters	061499	65 meals	199-36-6412.01-041-691000	Track meals for boys and girls	520.00	N
081934	04-09-2026	Rainbow Floral	061703	007141	199-41-6499.01-750-699000	Flowers/ Guastella Waskom ISD	158.00	N
081935	04-09-2026	Richard Holt Plumbing	061730	66168	199-51-6249.07-999-699000	HS Kitchen leak repair	316.00	N
081936	04-10-2026	Tina M Cox	061727	reimbursement	199-41-6499.01-750-699000	Christmas Decor supplies	82.81	N
081937	04-10-2026	Flatt Stationers Inc	061723	299919-00	199-11-6399.00-001-6110PA	Copy Paper	1,410.00	N
			061287	298336-00	199-11-6399.00-101-6110PA	Elem Copy Paper	455.85	N
						Totals for Check 081937	1,865.85	

For the Month of April

Check Nbr	Check Date	Payee	PO Nbr	Invoice Nbr	Fnd-Fnc-Obj.So-Org-Prog	Reason	Amount	EFT
081938	04-10-2026	Fissco Supply	061785	S102016937.001	199-51-6319.00-999-699000	A/C supplies Band Hall HS	547.28	N
081939	04-10-2026	Lowe's Home Center	061102	March 2026	199-51-6319.00-999-699000	Maintenance Supply	3,772.45	N
081940	04-10-2026	Marshall News Messenger	061747	Farm City Ad	199-11-6399.03-001-622000	Ad in newspaper	825.00	N
081941	04-10-2026	Tatum Music Company Inc	061670	March Supplies	199-11-6399.01-041-6110BD	Band supplies	170.17	N
081942	04-10-2026	TreviPay-Walmart	061530	da1d3773	199-41-6419.00-702-699000	Walmart Drink order- CO	71.95	N
081943	04-10-2026	Edwin Kelley	061768	200996	199-34-6249.00-999-699000	Repair Labor / Bus 1	1,245.00	N
081944	04-10-2026	Sabine Athletic Boosters	061644	entry fees	199-36-6499.00-999-691000	Entry Fees-HS Trk Sabine	550.00	N
081945	04-10-2026	Whataburger Resteraunts	061634	Or# 235512	199-36-6412.08-001-691000	SB Meals-Overton	231.20	N
081946	04-10-2026	Bart Bradley	061769	Bsb Official	199-36-6219.00-001-691000	Bsb Officials-Beckville	180.00	N
081947	04-10-2026	John S Coleman	061099	AG Consulting	199-11-6219.00-001-622000	HS Ag Consulting	7,500.00	N
081948	04-10-2026	Kerry Strong	061759	tennis meals	199-36-6412.04-001-691000	Regional tennis meals	488.00	N
081949	04-10-2026	Daniel Matthews	061770	Bsb Official	199-36-6219.00-001-691000	Bsb Officials-Beckville	180.00	N
081950	04-10-2026	William M Haynes	061756	Bsb Official	199-36-6219.00-001-691000	Bsb Officials-UG	105.00	N
081951	04-10-2026	T M Lumber Company	061015	Tran #231422	199-11-6399.03-001-622000	Lumber for projects	64.94	N
081953	04-13-2026	Waskom HS	060546	Apr-26	199-93-6492.00-999-623000	SSA Payment	17,654.07	N
081954	04-13-2026	David Tyrone Brown	061685	SRO Duty	199-52-6219.00-999-699000	SRO Duty	320.00	N
081955	04-14-2026	Agency 405 - TXDPS	060260	crs20260333200	199-41-6499.01-750-699000	Background check/Criminal hist	1.00	N
081956	04-14-2026	Blick Art Materials	061353	7675948	199-11-6399.09-001-611000	Art Classroom Supplies	80.10	N
081957	04-14-2026	Dealers Electrical Supply	061786	S101910242.001	199-51-6319.00-999-699000	Lights for District	1,152.00	N
081958	04-14-2026	Jodn D Barbe Graduate S	060960	3378	199-11-6499.05-001-611000	Honor Cords and Stoles	1,578.00	N
081959	04-14-2026	Hawkins Athletic Booster	061706	track meals	199-36-6412.09-001-691000	HS Trk Meals-Hawkins	480.00	N
081960	04-14-2026	Pliler International - Longvi	061795	x101039829:01	199-34-6319.00-999-699000	Transportation Supply	404.83	N
081961	04-14-2026	Sysco Food Services Of E.	060216	April 2026 1st	240-35-6341.00-999-699000	APR '26 GROCERY	7,192.42	N
			060216	April 2026 1st	240-35-6341.01-999-699000	APR '26 GROCERY	593.43	N
			060216	April 2026 1st	240-35-6342.00-999-699000	APR '26 GROCERY	976.91	N
Totals for Check 081961							8,762.76	
081962	04-14-2026	Tatum Music Company Inc	061670	April supplies	199-11-6399.01-041-6110BD	Band supplies	194.80	N
081963	04-14-2026	Union Grove Athletics	061780	OAP contest fee	199-36-6412.00-999-699000	UIL Area Fee	671.09	N
081964	04-14-2026	TreviPay-Walmart	061771	d9e189a1,	199-11-6399.00-101-611000	Elem Entrance Decor	59.76	N
081965	04-14-2026	Whataburger Resteraunts	061655	or# 128217	199-36-6412.08-001-691000	SB Meals-Overton	45.57	N
081966	04-14-2026	Anthony Robinson	061733	8 days /lessons	199-11-6219.00-001-6110BD	percussion section lessons	1,200.00	N
081967	04-14-2026	Texas Bandmasters Assoc	061796	14956&14963	199-11-6411.01-001-6110BD	Band Director Conference	400.00	N
081968	04-14-2026	Veloz Car Wash	061787	041710	199-34-6299.00-999-699000	District Vehicle wash	660.00	N

For the Month of April

Check Nbr	Check Date	Payee	PO Nbr	Invoice Nbr	Fnd-Fnc-Obj.So-Org-Prog	Reason	Amount	EFT
081969	04-14-2026	Amazon Capital Services	061668	3R36 & CM7G	199-53-6399.00-750-699000	CO Office Supplies	39.18	N
081970	04-14-2026	Trevin Stewart	061686	SRO Duty	199-52-6219.00-999-699000	SRO Duty	340.00	N
081971	04-16-2026	JP Gould Baxter - Longvie	061815	367190,367192	199-36-6399.01-001-691000	Detergent	469.25	N
081972	04-16-2026	Pete McCarty Oil Compan	061113	20806	199-34-6311.00-999-699000	Monthly Fuel delivery	2,316.31	N
081973	04-16-2026	Tatum Music Company Inc	061602	L646621	199-11-6649.00-001-6110BD	Band instruments	10,312.00	N
081974	04-16-2026	Whataburger Resteraunts	061628	or# 235612	199-36-6412.12-001-691000	Golf Tournament meals	112.40	N
081975	04-16-2026	Verizon Wireless	061152	March 2026	199-51-6259.02-999-699000	Monthly Cell Phone	396.50	N
081976	04-16-2026	Christi Siler	061736	Trans# 70037	199-36-6399.10-001-691000	HS Cheer TGCA renewal	138.50	N
081977	04-16-2026	Amazon Capital Services	061726	1n9fdj441lh	199-12-6329.02-999-699000	replacement library books	61.57	N
081978	04-16-2026	Texas Thesbians	061807	entry fees	199-11-6499.00-001-611000	Texas Thespian Contest	500.00	N
081979	04-16-2026	Phillip Haskell	061684	SRO Duty	199-52-6219.00-999-699000	SRO Duty	640.00	N
081980	04-21-2026	Crystal Brock	061853	meal money	199-11-6412.00-001-611000	HS Student Meals	1,512.00	N
081981	04-21-2026	JP Gould Baxter - Longvie	061808	367338	199-51-6319.01-999-699000	Janitorial Supplies	2,798.23	N
081982	04-21-2026	CDW Government	061765	A18V8T,	199-11-6399.12-001-611000	Misc Cables and Flash Drives	713.03	N
			061765	A18V8T,	199-11-6399.12-041-611000	Misc Cables and Flash Drives	237.68	N
			061765	A18V8T,	199-11-6399.12-101-611000	Misc Cables and Flash Drives	237.68	N
			061674	A181E1U	199-11-6649.03-001-611000	Lenovo Chromebox	401.53	N
Totals for Check 081982							1,589.92	
081983	04-21-2026	Datamax, Inc.	061249	2940362	199-11-6269.00-001-611000	Copier Lease Payment	309.54	N
			061249	2940362	199-11-6269.00-041-611000	Copier Lease Payment	309.54	N
			061249	2940362	199-11-6269.00-101-611000	Copier Lease Payment	309.54	N
			061249	2940362	199-41-6269.00-750-699000	Copier Lease Payment	309.53	N
Totals for Check 081983							1,238.15	
081984	04-21-2026	Flinn Scientific, Inc	061168	3249989	199-11-6399.05-001-6110CH	Physics Lab Supplies	332.43	N
081985	04-21-2026	ABC Auto # 18	061080	March 2026	199-34-6319.00-999-699000	Transportation Supply	125.17	N
081986	04-21-2026	Texas Defence Articulation	061825	1045	199-52-6299.00-999-699000	Security Training	1,946.00	N
081987	04-21-2026	Cut Time LLC	061794	26-73391	199-36-6412.00-999-699000	TSSEC entry fees	770.00	N
081988	04-21-2026	Amazon Capital Services	061767	1cvypqqg94hv	199-11-6399.03-101-623000	Elem Sped Classroom Supplies	52.79	N
081989	04-21-2026	Dionne Minchew	061829	p00xj5wcc61x2	199-36-6499.00-101-6990EL	Donut truck for staff on 5/5	400.00	N
081990	04-21-2026	AUTO-CHLOR Services L	060242	9187020&918836	240-35-6299.00-999-699000	APR '26 LEASE/SUPPLIES	238.00	N
081991	04-23-2026	Kim Hopkins	061798	reimbursement	199-11-6399.06-041-611000	reimbursement for subscription	66.00	N
081992	04-23-2026	Ore City Band Boosters	061859	#11	199-36-6499.00-041-6990BD	6th grade contest fee	100.00	N
081993	04-23-2026	Gwendolyn N Wright	061862	meal money	199-11-6412.00-001-621000	Meal \$ needed by 5/4/26	1,676.00	N
081994	04-23-2026	Tyler Gowanlock	061683	SRO Duty	199-52-6219.00-999-699000	SRO Duty	320.00	N
081995	04-23-2026	Trent Maguire	061690	SRO Duty	199-52-6219.00-999-699000	SRO Duty	320.00	N

For the Month of April

Check Nbr	Check Date	Payee	PO Nbr	Invoice Nbr	Fnd-Fnc-Obj.So-Org-Prog	Reason	Amount	EFT
081996	04-23-2026	Kydia Holland	061739	meal money	199-11-6412.00-001-621000	HS Robotics Trip Meals	108.00	N
081997	04-23-2026	STG Travel Inc	061857	1077	199-11-6412.02-001-622000	FBLA Hotel Reservation	2,340.00	N
081998	04-23-2026	Quentin Heath McFall	061688	SRO Duty	199-52-6219.00-999-699000	SRO Duty	340.00	N
081999	04-23-2026	Laura Horn	061745	#2	199-36-6219.00-001-6990BD	majorette judging	200.00	N
082000	04-23-2026	Isaac Barnett	061691	SRO Duty	199-52-6219.00-999-699000	SRO Duty	340.00	N
082001	04-23-2026	Daniel Young	061687	SRO Duty	199-52-6219.00-999-699000	SRO Duty	320.00	N
082002	04-23-2026	Madisyn Shaw Elliott	061744	2026-001	199-36-6219.00-001-6990BD	majorette judging	200.00	N
082003	04-23-2026	Ashleigh Russell	061746	2026-002	199-36-6219.00-001-6990BD	majorette judging	200.00	N
082004	04-24-2026	CDW Government	061262	ah8k53e&ah8ex1	199-11-6649.03-001-611000	HS Printers for UIL	292.56	N
082005	04-24-2026	Hughes Springs ISD	061417	entry fees	199-36-6499.01-001-691000	tennis entry fee	150.00	N
082006	04-24-2026	Jw Pepper & Son, Inc	061204	368503518	199-11-6399.01-001-6110BD	Band music	20.00	N
			061204	368503518	199-11-6399.01-101-6110BD	Band music	20.00	N
			061204	368503518	199-11-6399.02-001-6110BD	Band music	75.99	N
Totals for Check 082006							115.99	
082007	04-24-2026	Linden-Kildare High Schoo	061521	entry fees	199-36-6499.00-999-691000	HS/JH Trk Entry Fees-LK	475.00	N
082008	04-24-2026	Lock Doc of Texas	061561	D0K2RJ	199-51-6249.07-999-699000	rekey &lock	1,228.50	N
082009	04-24-2026	Chance Marett	061868	Bsb Official	199-36-6219.00-001-691000	Bsb Officials-EF	180.00	N
082010	04-24-2026	Chicken Express	061758	13 meals SB	199-36-6412.08-001-691000	SB Meals-Beckville	123.37	N
082011	04-24-2026	Jones Awards	061774	4018307	199-36-6499.05-041-699000	8th grade awards	92.25	N
082012	04-24-2026	Jucys Hamburgers LLC	061814	No. 0890	199-36-6412.08-001-691000	SB Meals-EF	115.79	N
082013	04-24-2026	Gregg County Historical F	061876	121345	199-11-6412.00-101-611000	4th grade field trip on 5/6/26	57.00	N
082014	04-24-2026	Daniel Matthews	061867	Bsb Official	199-36-6219.00-001-691000	Bsb Officials-EF	180.00	N
082015	04-24-2026	Flip N Cheer LLC	061849	3626	199-11-6499.01-001-6990HS	HS Staff incentives	228.00	N
082016	04-24-2026	Mack Fuller III	061689	SRO Duty	199-52-6219.00-999-699000	SRO Duty	340.00	N
082017	04-24-2026	Timothy Cline Livingston	061682	SRO Duty	199-52-6219.00-999-699000	SRO Duty	340.00	N
082018	04-24-2026	Phillip Haskell	061692	SRO Duty	199-52-6219.00-999-699000	SRO Duty	320.00	N
082019	04-24-2026	Trevin Stewart	061693	SRO Duty	199-52-6219.00-999-699000	SRO Duty	340.00	N
082020	04-27-2026	Postmaster	061902	2026-2027	199-11-6399.02-001-611000	Post Office Box Rental	358.00	N
082021	04-27-2026	Sysco Food Services Of E.	060216	April 2026 2nd	240-35-6341.00-999-699000	APR '26 GROCERY	5,212.02	N
			060216	April 2026 2nd	240-35-6341.01-999-699000	APR '26 GROCERY	781.94	N
			060216	April 2026 2nd	240-35-6342.00-999-699000	APR '26 GROCERY	638.85	N
Totals for Check 082021							6,632.81	
082022	04-27-2026	Carolyn Jones	061898	0000095	199-11-6269.01-101-611000	Student incentive party 4/27	508.00	N
082023	04-27-2026	Verdant Commercial Capit	061144	906084627	199-11-6269.00-001-611000	Copier Lease Payment	511.72	N

For the Month of April

Check Nbr	Check Date	Payee	PO Nbr	Invoice Nbr	Fnd-Fnc-Obj.So-Org-Prog	Reason	Amount	EFT
082024	04-29-2026	Gwendolyn N Wright	061943	park& trans fee	199-11-6411.00-001-611000	Parking and transportation	500.00	N
082025	04-29-2026	Fed Ex Office and Print	061913	quote147284314	199-11-6399.05-001-6110CH	Poster for ISEF	130.41	N
082026	04-29-2026	Gwendolyn N Wright	061949	meal money	199-11-6412.00-001-621000	HS Rocketry student meals	216.00	N
Total Checks							181,640.29	

End of Report

	SEPT	OCT	NOV	DEC	JAN	FEB	MARCH
ETEX TELEPHONE							
777-2372 GROUP	\$ 859.84	\$ 859.84	\$ 859.84	\$ 830.57	\$ 859.84	\$ 859.84	\$ 859.84
T-1 CIRCUIT	\$ 449.00	\$ 449.00	\$ 449.00	\$ 449.00	\$ 449.00	\$ 449.00	\$ 449.00
TOTAL	\$ 1,308.84	\$ 1,308.84	\$ 1,308.84	\$ 1,279.57	\$ 1,308.84	\$ 1,308.84	\$ 1,308.84
CENTERPOINT ENERGY-GAS							
BUS SHOP/PRIMARY-3214374-5	\$ 72.86	\$ 56.20	\$ 55.32	\$ 201.25	\$ 457.13	\$ 459.48	\$ 871.10
JH & ELEM BLDG-3214371-1	\$ 98.29	\$ 230.72	\$ 222.34	\$ 342.79	\$ 1,014.57	\$ 625.69	\$ 1,854.61
HIGH SCHOOL BLDG-2640504-3	\$ 128.99	\$ 193.89	\$ 179.26	\$ 209.17	\$ 511.64	\$ 393.53	\$ 712.22
FIELD HOUSE-2643737-6	\$ 63.21	\$ 77.25	\$ 71.14	\$ 70.27	\$ 65.88	\$ 65.53	\$ 65.38
TOTAL	\$ 363.35	\$ 558.06	\$ 528.06	\$ 823.48	\$ 2,049.22	\$ 1,544.23	\$ 3,503.31
UPSHUR RURAL ELECTRIC							
JH GYM-16655-001	\$ 782.40						
ELEM OUTDOOR BATHROOMS-16655-045							
JH & ELEM-16655-002	\$ 6,674.14	\$ 5,677.98	\$ 4,590.23	\$ 3,413.04	\$ 3,534.30	\$ 3,534.30	\$ 3,534.30
EL PE BLDG/MUSIC RM-16655-003	\$ 705.67	\$ 603.10	\$ 488.04	\$ 526.87	\$ 934.55	\$ 1,314.14	\$ 825.03
BUS BARN-16655-004	\$ 512.85	\$ 410.69	\$ (817.59)	\$ 274.67	\$ 321.95	\$ 402.35	\$ 371.90
TENNIS COURT-16655-012	\$ 27.57	\$ 27.52	\$ 32.44	\$ 26.17	\$ 28.43	\$ 30.30	\$ 36.05
FOOTBALL FIELD-16655-022	\$ 677.40	\$ 730.35	\$ 773.93	\$ 630.18	\$ 473.28	\$ 629.93	\$ 473.28
PRESS BOX/CONCESS. STD-16655-024	\$ 485.56	\$ 458.68	\$ 364.81	\$ 204.58	\$ 138.95	\$ 125.19	\$ 144.54
FLD HSE CONCESS. STD-16655-025	\$ 745.69	\$ 619.61	\$ 500.10	\$ 368.12	\$ 402.47	\$ 558.64	\$ 421.33
EL SECURITY LIGHT-16655-026	\$ 138.69	\$ 139.02	\$ 138.96	\$ 139.01	\$ 144.34	\$ 144.87	\$ 146.57
ELEM SCHOOL SIGN-16655-027	\$ 42.11	\$ 39.42	\$ 38.48	\$ 35.72	\$ 37.80	\$ 38.18	\$ 38.78
FLD HSE SEC LIGHT#2-16655-028	\$ 23.28	\$ 23.32	\$ 23.31	\$ 23.32	\$ 24.34	\$ 24.41	\$ 24.62
HIGH SCHOOL-16655-030	\$ 8,064.21	\$ 7,421.36	\$ 6,192.01	\$ 5,121.41	\$ 5,626.83	\$ 6,794.68	\$ 5,239.74
SOFTBALL FLD CONCESS-16655-031	\$ 73.46	\$ 71.60	\$ 75.24	\$ 67.90	\$ 69.87	\$ 61.30	\$ 156.56
WEIGHT ROOM-16655-032	\$ 976.24	\$ 830.88	\$ 739.04	\$ 584.89	\$ 613.26	\$ 817.76	\$ 755.16
SEC LIGHT TENNIS-16655-033	\$ 46.41	\$ 46.55	\$ 46.53	\$ 46.54	\$ 48.68	\$ 48.88	\$ 49.58
SIGN- 16655-036	\$ 47.94	\$ 45.12	\$ 44.79	\$ 41.83	\$ 44.91	\$ 44.67	\$ 45.14
CONCESSION 16655-037	\$ 237.67	\$ 199.01	\$ 165.67	\$ 206.38	\$ 240.05	\$ 533.60	\$ 467.77
STADIUM DR SECURITY LIGHT 16655-040	\$ 46.41	\$ 46.55	\$ 46.53	\$ 46.54	\$ 48.68	\$ 48.88	\$ 49.58
SOFTBALL FLD HOUSE-16655-041	\$ 135.24	\$ 136.19	\$ 120.79	\$ 102.94	\$ 85.87	\$ 128.81	\$ 122.54
HS FREEZER BLDG-166550-042	\$ 608.16	\$ 584.70	\$ 598.68	\$ 510.79	\$ 516.16	\$ 508.03	\$ 538.02
ARCHERY BLDG-166550-043	\$ 590.93	\$ 409.71	\$ 270.81	\$ 221.98	\$ 250.60	\$ 468.47	\$ 208.17
JH GYM A/C-166550-044	\$ 717.73	\$ 1,033.30	\$ 768.75	\$ 659.31	\$ 1,702.85	\$ 2,641.86	\$ 1,455.31
TOTAL	\$22,359.76	\$ 19,554.66	\$15,201.55	\$ 13,252.19	\$15,288.17	\$ 18,899.25	\$15,103.97
HARLETON WATER SUPPLY							
ACCT # 325 OLD CAMPUS	\$ 608.53	\$ 595.97	\$ 713.05	\$ 640.19	\$ 588.93	\$ 648.73	\$ 816.06
ACCT # 006 FOOTBALL FIELD	\$ 1,960.76	\$ 817.57	\$ 831.64	\$ 403.51	\$ 260.30	\$ 126.13	\$ 182.41
ACCT # 800 HIGH SCHOOL	\$ 187.43	\$ 189.95	\$ 190.95	\$ 187.94	\$ 195.47	\$ 167.33	\$ 177.89
ACCT # 1594 CONCESSION STAND	\$ 53.77	\$ 69.85	\$ 80.20	\$ 61.81	\$ 50.75	\$ 50.75	\$ 50.75
ACCT #1600 BASEBALL FIELD	\$ 2,173.31	\$ 1,838.15	\$ 1,114.55	\$ 892.94	\$ 545.72	\$ 400.49	\$ 313.06
ACCT #652 VISITOR CONCESSION STAND	\$ 1,444.19	\$ 495.97	\$ 459.29	\$ 642.70	\$ 420.59	\$ 231.65	\$ 207.53
ACCT #878 PRACTICE FIELD	\$ 720.99	\$ 156.78	\$ 365.32	\$ 161.30	\$ 160.30	\$ 174.37	\$ 156.78
ACCT #964 ARCHERY BLDG	\$ 65.93	\$ 109.95	\$ 46.73	\$ 29.65	\$ 31.66	\$ 30.15	\$ 29.65
	\$ 7,214.91	\$ 4,274.19	\$ 3,801.73	\$ 3,020.04	\$ 2,253.72	\$ 1,829.60	\$ 1,934.13

	APRIL	MAY	JUNE	JULY	AUGUST
ETEX TELEPHONE					
777-2372 GROUP	\$ 859.84	\$ 859.84			
T-1 CIRCUIT	\$ 449.00	\$ 449.00			
TOTAL	\$ 1,308.84	\$ 1,308.84			
CENTERPOINT ENERGY-GAS					
BUS SHOP/PRIMARY-3214374-5	\$ 219.51	\$ 196.96			
JH & ELEM BLDG-3214371-1	\$ 300.83	\$ 310.45			
HIGH SCHOOL BLDG-2640504-3	\$ 125.90	\$ 424.87			
FIELD HOUSE-2643737-6	\$ 66.33	\$ 66.46			
TOTAL	\$ 712.57	\$ 998.74			
UPSHUR RURAL ELECTRIC					
JH GYM-16655-001					
ELEM OUTDOOR BATHROOMS-16655-045		\$ 52.65			
JH & ELEM-16655-002	\$ 3,626.58	\$ 4,549.16			
EL PE BLDG/MUSIC RM-16655-003	\$ 636.57	\$ 519.27			
BUS BARN-16655-004	\$ 391.77	\$ 373.22			
TENNIS COURT-16655-012	\$ 33.74	\$ 30.86			
FOOTBALL FIELD-16655-022	\$ 473.28	\$ 473.28			
PRESS BOX/CONCESS. STD-16655-024	\$ 213.60	\$ 217.63			
FLD HSE CONCESS. STD-16655-025	\$ 465.82	\$ 440.66			
EL SECURITY LIGHT-16655-026	\$ 144.58	\$ 146.56			
ELEM SCHOOL SIGN-16655-027	\$ 41.26	\$ 42.02			
FLD HSE SEC LIGHT#2-16655-028	\$ 24.37	\$ 24.62			
HIGH SCHOOL-16655-030	\$ 5,415.38	\$ 6,183.18			
SOFTBALL FLD CONCESS-16655-031	\$ 159.27	\$ 160.31			
WEIGHT ROOM-16655-032	\$ 898.84	\$ 861.57			
SEC LIGHT TENNIS-16655-033	\$ 48.77	\$ 49.57			
SIGN- 16655-036	\$ 48.53	\$ 48.59			
CONCESSION 16655-037	\$ 441.52	\$ 487.64			
STADIUM DR SECURITY LIGHT 16655-040	\$ 48.77	\$ 49.57			
SOFTBALL FLD HOUSE-16655-041	\$ 134.74	\$ 151.25			
HS FREEZER BLDG-166550-042	\$ 454.83	\$ 514.56			
ARCHERY BLDG-166550-043	\$ 251.18	\$ 216.32			
JH GYM A/C-166550-044	\$ 814.82	\$ 584.71			
TOTAL	\$ 14,768.22	\$ 16,177.20			
HARLETON WATER SUPPLY					
ACCT # 325 OLD CAMPUS	\$ 1,166.81	\$ 1,000.48			
ACCT # 006 FOOTBALL FIELD	\$ 528.63	\$ 485.42			
ACCT # 800 HIGH SCHOOL	\$ 182.41	\$ 179.39			
ACCT # 1594 CONCESSION STAND	\$ 61.31	\$ 52.26			
ACCT #1600 BASEBALL FIELD	\$ 326.63	\$ 629.13			
ACCT #652 VISITOR CONCESSION STAND	\$ 250.25	\$ 472.35			
ACCT #878 PRACTICE FIELD	\$ 156.78	\$ 156.78			
ACCT #964 ARCHERY BLDG	\$ 32.16	\$ 28.64			
TOTAL	\$ 2,704.98	\$ 3,004.45			

HARLETON ISD

As of April

Fund 199 / 6 GENERAL OPERATING FUND

	Estimated Revenue (Budget)	Revenue Realized Current	Revenue Realized To Date	Revenue Balance	Percent Realized
5000 - RECEIPTS					
5700 - REVENUE - LOCAL & INTERMED					
5710 - LOCAL REAL-PROPERTY TAXES	1,813,250.00	-61,821.00	-1,612,722.40	200,527.60	88.94%
5720 - LOCAL REVENUE REALIZED AS A RE	41,000.00	-3,588.64	-27,214.12	13,785.88	66.38%
5730 - TUITION AND FEES	49,600.00	-650.00	-4,650.00	44,950.00	9.38%
5740 - OTHER REVENUES FROM LOCAL SOUR	82,515.00	-24.45	-54,027.94	28,487.06	65.48%
5750 - REVENUES FROM COCURRICULAR E	32,100.00	.00	-38,775.70	-6,675.70	120.80%
Total REVENUE - LOCAL & INTERMED	2,018,465.00	-66,084.09	-1,737,390.16	281,074.84	86.07%
5800 - STATE PROGRAM REVENUES					
5810 - PER CAPITA AND FOUNDATION SCHO	8,009,799.00	-404,579.00	-6,115,157.00	1,894,642.00	76.35%
5820 - STATE PROGRAM REVENUES	.00	.00	.00	.00	.00%
5830 - STATE REVENUES FROM STATE OF T	.00	.00	.00	.00	.00%
Total STATE PROGRAM REVENUES	8,009,799.00	-404,579.00	-6,115,157.00	1,894,642.00	76.35%
5900 - FEDERAL PROGRAM REVENUES					
5930 - FEDERAL REV DIST BY OTH TX GOV	.00	-43,909.67	-43,909.67	-43,909.67	.00%
5940 - FED REV DISTRIBUTED BY FEDS	24,237.00	.00	-11,955.49	12,281.51	49.33%
Total FEDERAL PROGRAM REVENUES	24,237.00	-43,909.67	-55,865.16	-31,628.16	230.50%
7000 - OTHER RESOURCES NON OPER REV					
7900 - OTHER RESOURCES NON OPER REV					
7910 - OTHER RESOURCES	.00	.00	.00	.00	.00%
Total OTHER RESOURCES NON OPER REV	.00	.00	.00	.00	.00%
Total Revenue Local-State-Federal	10,052,501.00	-514,572.76	-7,908,412.32	2,144,088.68	78.67%

HARLETON ISD

Fund 199 / 6 GENERAL OPERATING FUND

As of April

	<u>Budget</u>	<u>Encumbrance YTD</u>	<u>Expenditure YTD</u>	<u>Current Expenditure</u>	<u>Balance</u>	<u>Percent Expended</u>
6000 - EXPENDITURES						
00 - NO FUNCTION						
6100 - SALARIES AND BENEFITS	.00	.00	.00	.00	.00	.00%
Total Function00 NO FUNCTION	.00	.00	.00	.00	.00	.00%
11 - INSTRUCTION						
6100 - SALARIES AND BENEFITS	-4,847,073.00	.00	3,686,704.38	446,248.99	-1,160,368.62	76.06%
6200 - CONTRACTED SERVICES	-203,531.00	27,565.83	145,418.22	12,313.31	-30,546.95	71.45%
6300 - SUPPLIES AND MATERIALS	-138,675.00	24,935.78	90,302.47	8,455.23	-23,436.75	65.12%
6400 - TRAVEL AND SUBSISTENCE	-88,485.00	19,706.55	46,500.90	9,526.46	-22,277.55	52.55%
6600 - CAPITAL OUTLAY- LAND BLD EQUIP	-198,785.00	11,680.71	148,747.62	15,084.52	-38,356.67	74.83%
Total Function11 INSTRUCTION	-5,476,549.00	83,888.87	4,117,673.59	491,628.51	-1,274,986.54	75.19%
12 - INSTRUCTIONAL RESOURCES						
6100 - SALARIES AND BENEFITS	-311,504.00	.00	207,137.28	25,363.29	-104,366.72	66.50%
6200 - CONTRACTED SERVICES	-12,375.00	.00	12,763.53	.00	388.53	103.14%
6300 - SUPPLIES AND MATERIALS	-28,400.00	4,715.48	7,200.25	53.57	-16,484.27	25.35%
6400 - TRAVEL AND SUBSISTENCE	-12,800.00	7,556.57	1,502.98	.00	-3,740.45	11.74%
6600 - CAPITAL OUTLAY- LAND BLD EQUIP	-3,000.00	.00	.00	.00	-3,000.00	-0.00%
Total Function12 INSTRUCTIONAL RESOURCES	-368,079.00	12,272.05	228,604.04	25,416.86	-127,202.91	62.11%
13 - CURR DEV & INST STAFF DEV						
6100 - SALARIES AND BENEFITS	-71,015.00	.00	3,213.35	688.74	-67,801.65	4.52%
6200 - CONTRACTED SERVICES	-13,400.00	.00	7,358.49	.00	-6,041.51	54.91%
6300 - SUPPLIES AND MATERIALS	-700.00	.00	.00	.00	-700.00	-0.00%
6400 - TRAVEL AND SUBSISTENCE	-8,230.00	.00	1,481.54	.00	-6,748.46	18.00%
Total Function13 CURR DEV & INST STAFF DEV	-93,345.00	.00	12,053.38	688.74	-81,291.62	12.91%
23 - SCHOOL LEADERSHIP						
6100 - SALARIES AND BENEFITS	-464,919.00	.00	290,350.43	39,015.46	-174,568.57	62.45%
6200 - CONTRACTED SERVICES	-1,200.00	.00	.00	.00	-1,200.00	-0.00%
6300 - SUPPLIES AND MATERIALS	-7,700.00	269.52	5,485.60	151.52	-1,944.88	71.24%
6400 - TRAVEL AND SUBSISTENCE	-10,700.00	825.00	4,813.84	.00	-5,061.16	44.99%
6600 - CAPITAL OUTLAY- LAND BLD EQUIP	-1,800.00	.00	535.43	.00	-1,264.57	29.75%
Total Function23 SCHOOL LEADERSHIP	-486,319.00	1,094.52	301,185.30	39,166.98	-184,039.18	61.93%
31 - GUIDANCE COUNSELING						
6100 - SALARIES AND BENEFITS	-248,756.00	.00	165,033.55	20,846.77	-83,722.45	66.34%
6200 - CONTRACTED SERVICES	-1,305.00	.00	1,048.50	.00	-256.50	80.34%
6300 - SUPPLIES AND MATERIALS	-5,600.00	1,008.48	663.59	172.78	-3,927.93	11.85%
6400 - TRAVEL AND SUBSISTENCE	-4,100.00	825.00	3,133.41	.00	-141.59	76.42%
6600 - CAPITAL OUTLAY- LAND BLD EQUIP	-600.00	.00	.00	.00	-600.00	-0.00%
Total Function31 GUIDANCE COUNSELING	-260,361.00	1,833.48	169,879.05	21,019.55	-88,648.47	65.25%
33 - HEALTH SERVICES						
6100 - SALARIES AND BENEFITS	-46,017.00	.00	35,766.04	4,287.71	-10,250.96	77.72%
6200 - CONTRACTED SERVICES	-1,800.00	.00	.00	.00	-1,800.00	-0.00%
6300 - SUPPLIES AND MATERIALS	-1,500.00	105.00	1,259.79	.00	-135.21	83.99%
6400 - TRAVEL AND SUBSISTENCE	-250.00	.00	.00	.00	-250.00	-0.00%
6600 - CAPITAL OUTLAY- LAND BLD EQUIP	-2,500.00	.00	.00	.00	-2,500.00	-0.00%
Total Function33 HEALTH SERVICES	-52,067.00	105.00	37,025.83	4,287.71	-14,936.17	71.11%
34 - STUDENT TRANSPORTATION						
6100 - SALARIES AND BENEFITS	-173,424.00	.00	125,216.69	15,700.23	-48,207.31	72.20%
6200 - CONTRACTED SERVICES	-75,200.00	575.00	15,878.50	2,025.00	-58,746.50	21.12%
6300 - SUPPLIES AND MATERIALS	-97,600.00	22,000.00	51,822.66	7,288.61	-23,777.34	53.10%
6400 - TRAVEL AND SUBSISTENCE	-28,300.00	1,404.50	21,694.04	.00	-5,201.46	76.66%

	<u>Budget</u>	<u>Encumbrance YTD</u>	<u>Expenditure YTD</u>	<u>Current Expenditure</u>	<u>Balance</u>	<u>Percent Expended</u>
6000 - EXPENDITURES						
93 - PAYMENTS TO FISCAL AGENTS						
6400 - TRAVEL AND SUBSISTENCE	-162,440.00	35,308.14	141,232.56	17,654.07	14,100.70	86.94%
Total Function93 PAYMENTS TO FISCAL AGENTS	-162,440.00	35,308.14	141,232.56	17,654.07	14,100.70	86.94%
99 - OTHER INTERGOVERNMENTAL						
6200 - CONTRACTED SERVICES	-38,000.00	9,995.32	30,401.61	9,995.32	2,396.93	80.00%
Total Function99 OTHER INTERGOVERNMENTAL	-38,000.00	9,995.32	30,401.61	9,995.32	2,396.93	80.00%
8000 - OTHER USES NON-OPER EXPENSE						
00 - NO FUNCTION						
8900 - OPERATING TRANSFERS OUT/RESIDU	.00	.00	.00	.00	.00	.00%
Total Function00 NO FUNCTION	.00	.00	.00	.00	.00	.00%
Total Expenditures	-10,433,566.00	362,388.79	7,591,782.50	820,482.96	-2,479,394.71	72.76%

	Estimated Revenue (Budget)	Revenue Realized Current	Revenue Realized To Date	Revenue Balance	Percent Realized
5000 - RECEIPTS					
5700 - REVENUE - LOCAL & INTERMED					
5740 - OTHER REVENUES FROM LOCAL SOUR	100.00	.00	-277.74	-177.74	277.74%
5750 - REVENUES FROM COCURRICULAR E	57,349.00	-3,236.04	-22,670.69	34,678.31	39.53%
Total REVENUE - LOCAL & INTERMED	57,449.00	-3,236.04	-22,948.43	34,500.57	39.95%
5800 - STATE PROGRAM REVENUES					
5820 - STATE PROGRAM REVENUES	25,000.00	-1,975.21	-3,552.09	21,447.91	14.21%
5830 - STATE REVENUES FROM STATE OF T	.00	.00	.00	.00	.00%
Total STATE PROGRAM REVENUES	25,000.00	-1,975.21	-3,552.09	21,447.91	14.21%
5900 - FEDERAL PROGRAM REVENUES					
5920 - FEDERAL REV FROM TEA	427,000.00	-46,201.81	-317,044.07	109,955.93	74.25%
Total FEDERAL PROGRAM REVENUES	427,000.00	-46,201.81	-317,044.07	109,955.93	74.25%
Total Revenue Local-State-Federal	509,449.00	-51,413.06	-343,544.59	165,904.41	67.43%

	<u>Budget</u>	<u>Encumbrance YTD</u>	<u>Expenditure YTD</u>	<u>Current Expenditure</u>	<u>Balance</u>	<u>Percent Expended</u>
6000 - EXPENDITURES						
35 - FOOD SERVICE						
6100 - SALARIES AND BENEFITS	-203,449.00	.00	137,084.55	16,004.17	-66,364.45	67.38%
6200 - CONTRACTED SERVICES	-28,300.00	2,319.02	18,960.65	1,493.45	-7,020.33	67.00%
6300 - SUPPLIES AND MATERIALS	-260,500.00	29,867.00	172,560.65	31,349.04	-58,072.35	66.24%
6400 - TRAVEL AND SUBSISTENCE	-700.00	250.00	.00	.00	-450.00	-.00%
6600 - CAPITAL OUTLAY- LAND BLD EQUIP	-15,000.00	.00	.00	.00	-15,000.00	-.00%
Total Function35 FOOD SERVICE	-507,949.00	32,436.02	328,605.85	48,846.66	-146,907.13	64.69%
51 - FACILITIES MAINT & OPER						
6200 - CONTRACTED SERVICES	-1,500.00	350.36	865.63	87.59	-284.01	57.71%
Total Function51 FACILITIES MAINT & OPER	-1,500.00	350.36	865.63	87.59	-284.01	57.71%
Total Expenditures	-509,449.00	32,786.38	329,471.48	48,934.25	-147,191.14	64.67%

Comparison of Revenue to Budget

HARLETON ISD

As of April

Fund 599 / 6 DEBT SERVICE FUNDS

	Estimated Revenue (Budget)	Revenue Realized Current	Revenue Realized To Date	Revenue Balance	Percent Realized
5000 - RECEIPTS					
5700 - REVENUE - LOCAL & INTERMED					
5710 - LOCAL REAL-PROPERTY TAXES	134,714.00	-4,821.35	-125,111.08	9,602.92	92.87%
5740 - OTHER REVENUES FROM LOCAL SOUR	100.00	-1.03	-57.17	42.83	57.17%
Total REVENUE - LOCAL & INTERMED	134,814.00	-4,822.38	-125,168.25	9,645.75	92.85%
5800 - STATE PROGRAM REVENUES					
5820 - STATE PROGRAM REVENUES	17,154.00	.00	-47,481.00	-30,327.00	276.79%
Total STATE PROGRAM REVENUES	17,154.00	.00	-47,481.00	-30,327.00	276.79%
7000 - OTHER RESOURCES NON OPER REV					
7900 - OTHER RESOURCES NON OPER REV					
7910 - OTHER RESOURCES	.00	.00	.00	.00	.00%
Total OTHER RESOURCES NON OPER REV	.00	.00	.00	.00	.00%
Total Revenue Local-State-Federal	151,968.00	-4,822.38	-172,649.25	-20,681.25	113.61%

	<u>Budget</u>	<u>Encumbrance YTD</u>	<u>Expenditure YTD</u>	<u>Current Expenditure</u>	<u>Balance</u>	<u>Percent Expended</u>
6000 - EXPENDITURES						
71 - DEBT SERVICE						
6500 - DEBT SERVICE	-151,968.00	.00	151,867.50	.00	-100.50	99.93%
Total Function71 DEBT SERVICE	-151,968.00	.00	151,867.50	.00	-100.50	99.93%
8000 - OTHER USES NON-OPER EXPENSE						
00 - NO FUNCTION						
8900 - OPERATING TRANSFERS OUT/RESIDU	.00	.00	.00	.00	.00	.00%
Total Function00 NO FUNCTION	.00	.00	.00	.00	.00	.00%
Total Expenditures	-151,968.00	.00	151,867.50	.00	-100.50	99.93%

HARLETON ISD
BANK ACCTS
BALANCES

INVESTMENTS

ACCT NAME	MATURITY DATE	INT. RATE	ACCT #	BAL AS OF 05-12-26	MARKET VALUE
OPERATING		0.05%	15396	\$ 1,993,392.64	AS OF 4-30-2026
DEBT SERVICE		0.05%	15479	\$ 30,736.74	
PAYROLL		0.05%	744318	\$ 72,164.65	
WORKERS COMP		0.05%	21873	\$ 4,819.20	
MONEY MARKET		0.05%	1023456	\$ 3,426.33	
TOTAL				\$ 2,104,539.56	
WILDCAT		0.05%	15339	\$ 145,476.70	
MISCELLANEOUS		0.05%	15495	\$ 362.34	
				\$ 145,839.04	
ACADEMIC ACHIEVEMENT		0.05%	15487	\$ 56,659.16	
TOTAL				\$ 2,104,539.56	
TOTAL CHECKING				\$ 2,307,037.76	
GENERAL OPERATING FUND					
CERTIFICATE OF DEPOSIT	9/28/2027	4.00%	56001565	\$ 607,508.67	
CERTIFICATE OF DEPOSIT	9/28/2027	4.00%	56001573	\$ 607,508.67	
TOTAL				\$ 3,522,055.10	
LONE STAR INVESTMENT POOL	OPERATING	3.82%	1023456-1	\$	4,682,212.18
LONE STAR INVESTMENT POOL	DEBT SERVICE	3.82%	1023456-1	\$	398,787.51
				\$	5,080,999.69

This report is in compliance with the investment strategies as established in the District's investment policy and the reporting requirements as mandated by the Public Funds Investment Act (Chapter 2256) as amended.

INVESTMENT OFFICER'S SIGNATURE 

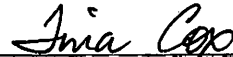
INVESTMENT OFFICER'S SIGNATURE 



Harleton
Independent School District

Jay Ratcliff
Superintendent

**HARLETON ISD
FIELD TRIP REQUEST FORM**

Employee Requesting: Christi Speer

Class or Organization Attending: HS Band Drum Majors

Location of Trip: Panola College

Purpose of the Trip: Drum Major Camp

Date Leaving: 6/14/26

Time Leaving: 8 AM

Date Returning: 6/18/26

Time Returning: 6 PM

Approximate Number of Students Attending: 2

Number of Chaperones/Teachers: 1

Number of Buses: 0

Chaperone/Teacher Names: Speer will drop students off. Speer and their parents will pick up.

Bus Drivers: 0

Estimated Cost per Student \$ 395

Student or School Funded school

If School Funded, Account Code: 199-36-6489 02-001-6990E _____

Purchase Order Entered: yes

Transportation Request Emailed: yes

Purchase Order Amount: \$790

Deposit Required: \$ _____ Credit Card or Check: _____

Paid: _____ Bal. Due: _____

Additional Information: This is the same military drum major camp we send our leaders to each year for drum major training. They stay on campus at panola and spend each day learning drum major skills and leadership skills. I do not stay at camp with them, but I often go by during the week to check on them.

Principal's Signature: *Christi Speer* Date: 4/21/26

Superintendent's Signature: _____ Date: _____

OVERNIGHT OR OUT OF STATE TRIPS MUST HAVE BOARD APPROVAL

Board Approval: Yes _____ No _____ Date: _____



Harleton
Independent School District

Jay Ratcliff
Superintendent

**HARLETON ISD
FIELD TRIP REQUEST FORM**

Employee Requesting: Katlyn French

Class or Organization Attending: FFA

Location of Trip: Fort Worth

Purpose of the Trip: State Convention

Date Leaving: July 5th Time Leaving: noon

Date Returning: July 10th Time Returning: noon

Approximate Number of Students Attending: 10

Number of Chaperones/Teachers: 2

Number of Buses: 2 vans

Chaperone/Teacher Names: _____

Bus Drivers: _____

Katlyn French

Maddison Ratcliff

Estimated Cost per Student \$ _____

Student or School Funded _____

If School Funded, Account Code: _____

Purchase Order Entered: _____

Transportation Request Emailed: _____

Purchase Order Amount: _____

Deposit Required: \$ _____ Credit Card or Check: _____

Paid: _____ Bal. Due: _____

Additional Information: _____

Principal's Signature: Crystal Brown Date: _____

Superintendent's Signature: _____ Date: _____

OVERNIGHT OR OUT OF STATE TRIPS MUST HAVE BOARD APPROVAL

Board Approval: Yes _____ No _____ Date: _____

RESOLUTION REGARDING INABILITY TO PURCHASE SCHOOL BUSES

FOR COMPLIANCE WITH SENATE BILL 546

The Harleton Independent School District Board of Trustees

WHEREAS, Senate Bill 546 establishes requirements for school districts regarding school bus fleet compliance and safety standards; and WHEREAS, the District has determined that eleven (11) new school buses are necessary to achieve full compliance with the provisions of Senate Bill 546; and WHEREAS, the estimated cost for the purchase of eleven (11) new school buses, including necessary equipment and specifications required by SB 546, is substantial and represents a significant financial obligation; and

WHEREAS, the District has conducted a comprehensive review of its current budget allocation and available financial resources; and WHEREAS, despite careful budget management and exploration of available funding sources, the district has insufficient funds in the current fiscal year budget to complete the purchase of eleven (11) new school buses; and

WHEREAS, the District remains committed to student safety and transportation excellence while maintaining fiscal responsibility and avoiding actions that would create budget shortfalls or jeopardize other essential educational programs and services; and WHEREAS, the District acknowledges its obligation to work toward compliance with SB 546 and will continue to explore funding opportunities, including but not limited to state funding assistance, grant programs, and future budget allocations; and

WHEREAS, the Board of Trustees recognizes the importance of maintaining transparency with the community regarding budgetary constraints and compliance challenges;

NOW, THEREFORE, BE IT RESOLVED by the Board of Trustees of the District that: SECTION 1: DETERMINATION The Board of Trustees hereby determines that the district is currently unable to purchase eleven (11) new school buses required for compliance with Senate Bill 546 due to insufficient budgetary resources in the current fiscal year.

SECTION 2: COMMITMENT TO FUTURE COMPLIANCE The Board directs the Superintendent and administrative staff to:

1. Continue to monitor and evaluate budgetary capacity for the purchase of compliant school buses in future fiscal years;
2. Actively pursue state funding, grants, and other financial assistance programs that may support the acquisition of school buses meeting SB 546 requirements;
3. Develop a multi-year capital improvement plan that prioritizes school bus fleet modernization and compliance with state mandates.
4. Provide regular updates to the Board regarding progress toward compliance and availability of funding sources.

SECTION 3: BUDGETARY PRUDENCE The Board reaffirms its commitment to responsible fiscal management and directs that no purchases shall be made that would create budget shortfalls or compromise the district's financial stability.

RESOLUTION REGARDING INABILITY TO PURCHASE SCHOOL BUSES

FOR COMPLIANCE WITH SENATE BILL 546

SECTION 4: COMMUNICATION The Superintendent and/or his Designee is authorized and directed to communicate this resolution to the Texas Education Agency and other appropriate state agencies, and to maintain ongoing dialogue regarding compliance timelines and available assistance.

SECTION 5: EFFECTIVE DATE This resolution shall take effect immediately upon passage.

PASSED AND ADOPTED this ____ day of _____, 20____. BOARD OF TRUSTEES

Board President

Board Secretary

ATTEST: _____
Superintendent

BUCK'S WHEEL
& EQUIPMENT

5101 N. MAIN ST
FORT WORTH, TX 76179
PHONE 817-332-1228
FAX 817-332-1817



Quote

Date	Quote #
3/16/2026	38546
Rep	

Name / Address
HARLETON ISD 17000 SH 154 HARLETON, TX 75651

Ship To

UNIT #	Customer E-mail	Customer Phone	Customer Fax
	HARPERMIKE@HARLE...	903-777-2372	

Item	Description	Qty	Rate	Total
PARTS	NEX GEN, 39" SEAT ASSEMBLY ONLY WITH (3) 3-POINT SEAT BELTS, GRAY FIREBLOCK VINYL	26	950.25	24,706.50
LABOR	REMOVE ALL EXISTING SEATS AND HARDWARE, INSTALL NEW 3PT SEAT BELT SEATS WITH NEW MOUNTING HARDWARE	1	6,500.00	6,500.00
PARTS	RETROFIT MOUNTING KIT	26	36.52	949.52
SHOP PARTS	SHOP PARTS / MISC. EXPENSE HARDWARE / WASTE FEE	1	650.00	650.00
LABOR	REPLACING FLOOR	1	7,000.00	7,000.00
	*****THIS IS A GENERIC QUOTE FOR A 77 PASSENGER BUS*****			
	*****PRICING CAN CHANGE DEPENDING ON THE MOUNTING OF THE SEATS AND IF THE FLOOR NEEDS TO BE REPLACED.*****			
	*****QUOTE VALID FOR 30 DAYS*****			

Subtotal	\$39,806.02
Sales Tax (0.0%)	\$0.00
Total	\$39,806.02

TRANS. PHONE #

TRANS. FAX #

BUCK'S WHEEL
& EQUIPMENT

5101 N. MAIN ST
FORT WORTH, TX 76179
PHONE 817-332-1228
FAX 817-332-1817



Quote

Date	Quote #
3/16/2026	38547
Rep	

Name / Address
HARLETON ISD 17000 SH 154 HARLETON, TX 75651

Ship To

UNIT #	Customer E-mail	Customer Phone	Customer Fax
	HARPERMIKE@HARLE...	903-777-2372	

Item	Description	Qty	Rate	Total
PARTS	NEX GEN, 39" SEAT ASSEMBLY ONLY WITH (3) 3-POINT SEAT BELTS, GRAY FIREBLOCK VINYL	24	950.25	22,806.00
LABOR	REMOVE ALL EXISTING SEATS AND HARDWARE, INSTALL NEW 3PT SEAT BELT SEATS WITH NEW MOUNTING HARDWARE	1	6,500.00	6,500.00
PARTS	RETROFIT MOUNTING KIT	24	36.52	876.48
SHOP PARTS	SHOP PARTS / MISC. EXPENSE HARDWARE	1	650.00	650.00
LABOR 909	REMOVE AND REPLACE THE SUBFLOOR AND VINYL FLOORING	1	7,000.00	7,000.00
	*****FLOOR MUST BE REPLACED DUE TO LIABILITY REASONS PER THE SEAT MANUFACTURER*****			
	*****THIS IS A GENERIC QUOTE FOR A 71 / 72 PASSENGER BUS*****			
	*****PRICING CAN CHANGE DEPENDING ON THE MOUNTING OF THE SEATS.*****			
	*****QUOTE VALID FOR 30 DAYS*****			

Subtotal	\$37,832.48
Sales Tax (0.0%)	\$0.00
Total	\$37,832.48

TRANS. PHONE #

TRANS. FAX #

Quote

04/17/2026

Project:
Harleton ISD - convection oven

From:
Kirby Restaurant Supply Co.
Dave Newman
809 S Eastman Rd
Longview, TX 75602
903-757-2723
903-746-0421 (Contact)

Item	Qty	Description	Sell	Sell Total
1	1 ea	CONVECTION OVEN, GAS Blodgett (Middleby) Model No. ZEPH-200-G DBL Zephrae Convection Oven, gas, double-deck, bakery depth	\$17,954.00	\$17,954.00
	1 ea	Natural gas		
	2 ea	115v/60/1-ph, 6.0 amps, 2-wire with ground, cord & plug, 1/2 hp (per deck), standard		
	1 ea	SSI-M Top Oven: Solid State Infinite control with 60 min. manual timer		
	1 ea	SSI-M Bottom Oven: Solid State Infinite control with 60 min. manual timer		
	1 ea	Venting to be determined		
	1 st	6" plate casters (set)	\$282.00	\$282.00
	1 ea	Gas manifold for double ovens	\$314.00	\$314.00
	1 ea	Krowne M7548K Royal Series Moveable Gas Connection Kit, 3/4" I.D., 48" long, stainless steel corrugated tubing & radial wrap with green antimicrobial PVC coating, quick disconnect, (1) full port gas valve, (2) 90° elbows, restraining cable with mounting hardware, 180,000 BTU/hr minimum flow capacity	\$205.00	\$205.00
			ITEM TOTAL:	\$18,755.00
2	1 ea	DELIVERY AND INSTALLATION KIRBY RESTAURANT SUPPLY Model No. KIRBY DELIVERY AND INSTALLATION DELIVERY AND INSTALLATION to include delivery to jobsite, uncrating, assembly and setting it in place for final electrical, plumbing, waste and mechanical connections by other. Customer is responsible for proper voltage and site preparation.	\$2,077.00	\$2,077.00
			ITEM TOTAL:	\$2,077.00
			Subtotal	\$20,832.00
			Total	\$20,832.00

Acceptance: _____ Date: _____

Printed Name: _____

Project Grand Total: \$20,832.00

To:
HARLETON ISD
Connie Burrell
903-777-1541 (Contact)



Project:
HARLETON ISD Elementary - Oven

From:
Reliance Refrigeration &
Restaurant Supply, LLC
David Witt
905 Alumax Dr
Nash, TX 75569
(903)794-8021
903-235-8655 (Contact)

Job Reference Number: DW13737PHI

WE ARE PLEASED TO PRESENT THESE SPECIFICATIONS AND PRICES FOR YOUR CONSIDERATION:

Reliance Refrigeration is committed to providing the best products and services for our clients, at the best pricing available. Due to the current trade relationships, some equipment may have price increases between quoting, ordering, and receiving. To secure the best pricing, please speak with your Reliance representative to consider the best options.

Item	Qty	Description	Sell	Sell Total
1	1 ea	CONVECTION OVEN, GAS  Montague Company Model No. HX2-63A Vectaire Convection Oven, gas, double-deck, bakery depth, two-speed motor, electronic ignition and solid state controls, stainless steel front, top & sides, 3" high flue deflector with stainless steel front trim, 6" high stainless steel legs, 126,000 BTU, NSF, CSA Star, CSA Flame	\$23,575.00	\$23,575.00
	1 ea	Standard K-12warranty: three year parts and labor warranty		
	1 ea	Lifetime door warranty, standard		
	1 ea	Natural gas		
	1 ea	(2) 120v/60/1ph, 7.2 amps, 1/2 hp, cord with 3-prong plug.		
	1 ea	SHIPPNG AND HANDLING SHIPPNG AND HANDLING	\$1,260.00	\$1,260.00
2	2 kt	GAS CONNECTOR HOSE KIT / ASSEMBLY  BK Resources Model No. 10-754-1 Packed 1 kt GOTek Gas Connectors Kit, 3/4" x 48", with shut-off valve and quick disconnect, braided stainless steel over a 304 corrugated stainless steel connector, protective translucent coating, includes (1) shut off valve, (1) quick connect fitting, (1) restraining cable & hardware, (2) female to Male 90° elbow, (4) screws, (4) plastic anchors, CSA (NET)	\$260.00	\$520.00
	2 kt	5 year warranty, standard		

Item	Qty	Description	Sell	Sell Total
3	1 ea	INSTALL Reliance Refrigeration & Restaurant Supply Model No. INSTALL Scope of work to be performed: - Removal & Disposal of existing equipment - Delivery & set up of new equipment - Make final connection. - Verify Equipment Functionality before departure *** Connecting to existing utilities *****	\$2,145.00	\$2,145.00
4	1 ea	SERVICES: INSTALLATION / TRAINING SERVICES Reliance Refrigeration & Restaurant Supply Model No. EXCLUDES Excludes: Electrical work of any kind, structural, painting, abatement, cutting holes in roofing/decking systems for mechanical penetrations, conduit, roofer or roof work of any kind (other than spotting holes), sheetrock work of any kind, ceiling grid repair/replacement, structural supports or framing, landscaping, irrigation repairs, and concrete work of any kind.		
Total				\$27,500.00

Service Terms and Conditions

1. Reliance Refrigeration & Restaurant Supply, hereafter referred to as DEALER, has offered a fixed contract price for equipment and/or services, referred to as GOODS, which is contingent upon the scope quoted being accepted and commenced within 30 days from proposal date. Proposals are to be interpreted exactly as specified; proposals not specifying installation, delivery, freight, tax, labor, or any materials/accessories should not assume those items in total. Labor and material breakdowns will not be provided.
2. Payments are due by the date specified on the invoice. Any payment not received by 5:00 PM on the due date will incur a 1% late fee. For payments made by mailed check, the check must be postmarked on or before the due date to avoid late fees. To ensure timely payments, please schedule your project milestones to align with your internal business payment meetings. Debit or credit card transactions exceeding \$500 will incur a 3.5% processing fee. To avoid this fee, consider paying by check or cash, or contact your representative to discuss alternative payment options. Failure to adhere to these payment terms may result in project delays and/or legal action.
3. Proposals EXCLUDE, unless otherwise stated in writing, electrical, structural, painting, abatement, cutting holes in roofing/decking systems for mechanical penetrations, conduit, roofer or roof work of any kind (other than spotting holes), sheet-rock work of any kind, structural supports or framing, landscaping, irrigation repairs, concrete work of any kind, utility upgrade, utility final connection, and start up of equipment. Payment for the work described herein shall be immediately due

upon completion of the work, unless an account is established with agreed terms. If suggested options are not chosen by the person/agent receiving services, hereafter referred to as CUSTOMER, and a failure is experienced, the DEALER is held harmless.

4. Lead times from manufacturers are estimates only. DEALER is not responsible for manufacturer lead times. DEALER works with each vendor to supply CUSTOMER with GOODS as quickly as able. Deadlines should be communicated in writing between DEALER and CUSTOMER.
5. The scope of work for GOODS is related to that described above. Any deviation from said scope of work or unforeseen problems delaying the timely completion of the job may incur an additional charge. All work will be done in accordance with state and local codes.
6. DEALER reserves the right to refuse or stop the work at any time due to unsafe or unforeseen conditions that may change the scope of work. DEALER will evaluate the conditions and submit a proposal to solve and remedy the problem. Work will continue after the CUSTOMER and DEALER have come to a signed agreement. If no agreement can be reached, DEALER will collect payment for the portions of the work completed up to the time the job ceased at the regular rates of the DEALER and the customer agrees to hold harmless from all actions, claims, demands and/or penalties.
7. If conditions and/or circumstances are encountered at the job site which are concealed physical conditions, or unknown physical conditions of an unexpected or unusual nature, which differ materially from that which is visually ascertained, CUSTOMER agrees to accept responsibility for such conditions and those circumstances outside the control of DEALER and further agrees to pay for any labor or materials, including repair to damaged equipment of DEALER caused by such conditions and/or circumstances.
8. It is the intent of this provision to make CUSTOMER responsible for all unforeseen and concealed conditions, and for that which DEALER cannot control. Accordingly, CUSTOMER further agrees to hold DEALER harmless and shall indemnify and defend DEALER and all its agents and employees from and against all claims, damages, losses and expenses, including but not limited to attorney fees, consequential damages, arising from or as a result of the performance of DEALER'S work involving, affecting, or relating to such unforeseen or concealed conditions regardless of whether such damages are caused in part by DEALER.
9. DEALER will always try to minimize the damage to the work area, but shall not be responsible for any concrete, asphalt, walls/drywall, cabinets, sod, landscaping, sprinklers, water lines, gas lines, cable TV lines, pool re-circulation lines, pool filtration lines, or any other utility lines, walkways, driveways, flooring, and/or any other structural damage to the property. Backfill for projects that require excavation will be completed to the best of the DEALERS ability. However,

weather conditions and soil type greatly affect the appearance of finished backfill.

10. Asbestos or other Hazardous Materials Remediation Work - DEALER has no information whatsoever with respect to asbestos or other hazardous materials or substances in any portion of the CUSTOMER'S property and has not conducted any investigation in connection herewith. DEALER does not perform asbestos or other hazardous materials or substance removal and DEALER shall have no responsibility whatsoever and CUSTOMER expressly releases DEALER from any liability whatsoever and for any claims arising out of its presence, release, remediation or removal and for any costs, losses or damages CUSTOMER may suffer or sustain if it is found to exist on the CUSTOMER'S property. In the event asbestos or other hazardous materials or substances are found to exist on the CUSTOMER'S property or if, in order to obtain a building permit for the work to be performed by DEALER as set forth herein, any remediation action or work, including investigation is required to be performed on the CUSTOMER'S property concerning asbestos or other hazardous materials or substances, all work by DEALER will cease until such time as CUSTOMER has, at CUSTOMER'S sole expense, caused said asbestos or other hazardous materials or substances to be removed in compliance with all applicable laws relating thereto.
11. DEALER warrants its workmanship to be free from defects unless otherwise specified in writing. This warranty becomes effective upon completion of work but does not cover faults caused by misuse, negligence, or damage caused by acts of God. Upon completion of the work, CUSTOMER agrees to exercise due diligence in inspecting the work for defective workmanship and materials. CUSTOMER agrees to notify DEALER immediately upon discovery of any alleged defective work and allow DEALER first opportunity to make repairs. The failure to allow DEALER the first opportunity to repair the allegedly defective work shall void all warranties, express and implied here-under. DEALER is not responsible for reimbursement for work performed by any other company or individual. Any workmanship warranty becomes void if payment is not received by due date. Warranties are extended only to the CUSTOMER and are non-transferrable. This warranty DOES NOT cover labor charges for the correction, replacement, or repair due to manufacturer defects. Labor charges are the responsibility of the CUSTOMER and due at the time of service.
12. RETURN POLICY: Return of GOODS must follow manufacturer guidelines. GOODS that are requested to be returned must be returned in the original packaging. GOODS that were installed and/or used are not eligible for return. GOODS that were connected to utilities are not eligible for return. CUSTOMER is responsible for any restocking fees for DEALER to receive GOODS. Some equipment is made custom for CUSTOMER and is not eligible for return. Custom-made items are not identified in any particular manner; CUSTOMER is responsible for knowledge of custom-made equipment. CUSTOMER agrees to be responsible for payment of GOODS in full, following agreed upon terms, for any situation not eligible for return.

Acceptance: _____ Date: _____

Printed Name: _____

Project Grand Total: \$27,500.00







Quote

04/24/2026

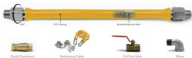
Project:
Harleton ISD

From:
Restaurant Source & Supply
Sissy Worley
12265 State Highway 64 W
Tyler, Texas 75704
903-630-3110
903-630-3110 (Contact)

Item	Qty	Description	Sell	Sell Total
1	1 ea	CONVECTION OVEN, GAS  Vulcan Model No. VC55GD Convection Oven, gas, double-deck, standard depth, solid state controls, electronic spark ignition, 5-hour timer with digital display enhancement , 150° to 500°F temperature range, (5) oven racks per deck, independently operated removable doors with windows, porcelain on steel interior, interior light, stainless steel front, top, sides & 8"H legs, (2) 1/2 HP blower motors, (2) 50,000 BTU, NSF, CSA Star, CSA Flame, ENERGY STAR® 1 ea 1 year limited parts & labor warranty, standard 1 ea Natural gas (specify elevation if over 2,000 ft.) 1 ea (2) 120v/60/1-ph, 15.4 amps total, (2) cords with plugs, standard 1 ea Gas manifold piping included with stacking kit to provide single point gas connection	\$12,266.63	\$12,266.63
			ITEM TOTAL:	\$12,266.63
4	2 ea	GAS CONNECTOR HOSE KIT / ASSEMBLY  Klinger's Trading Model No. GH75KIT48 Easyflex® Commercial Gas Connector Kit, 3/4" inside dia., includes: 48" long PVC-coated, non-flammable braided stainless steel hose with 360° rotational ends, quick disconnect, restraining cable, full port valve & (2) 90° elbows, cCSAus (NET price) (tariff exempt)	\$149.00	\$298.00
			ITEM TOTAL:	\$298.00
2	1 ea	CONVECTION OVEN, GAS	\$12,130.63	\$12,130.63

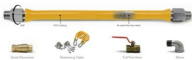
Item	Qty	Description	Sell	Sell Total
		Vulcan Model No. VC44GD Convection Oven, gas, double-deck, standard depth, solid state controls, electronic spark igniters, 60 minute timer , (5) nickel plated racks per oven, stainless steel front, top, sides & 8"H legs, stainless steel doors with windows, (2) 50,000 BTU, NSF, CSA Star, CSA Flame, ENERGY STAR®		
	1 ea	1 year limited parts & labor warranty, standard		
	1 ea	Natural gas (specify elevation if over 2,000 ft.)		
	1 ea	(2) 120v/60/1-ph, 15.4 amps total, (2) cords with plugs, standard		
	1 ea	Gas manifold piping included with stacking kit to provide single point gas connection		
			ITEM TOTAL:	\$12,130.63
5	2 ea	GAS CONNECTOR HOSE KIT / ASSEMBLY Klinger's Trading Model No. GH75KIT48 Easyflex® Commercial Gas Connector Kit, 3/4" inside dia., includes: 48" long PVC-coated, non-flammable braided stainless steel hose with 360° rotational ends, quick disconnect, restraining cable, full port valve & (2) 90° elbows, cCSAus (NET price) (tariff exempt)	\$149.00	\$298.00
				
			ITEM TOTAL:	\$298.00
3	1 ea	CONVECTION OVEN, GAS Dukers Appliance Co., USA Ltd. Model No. DCCOG2 Convection Oven, gas, double-deck, 38"W x 39-3/4"D x 68-1/2"H, standard depth, 50/50 dependent doors with double pane thermal tempered glass, 175°F to 500°F temperature range, digital controller , 2-speed-fan with adjustable cool down mode, interior lighting, (5) wire racks (per oven), removable 11-position rack guides (per oven), door interlock switches, automatic pilot system with safety shut-off, stainless steel exterior, includes leg kit with (4) stainless steel legs & locking casters, 108,000 BTU/HR, cCSAus, CSA-Sanitation	\$7,868.91	\$7,868.91
				
	1 ea	NOTE: Pricing does not include transportation, installation, removal of old unit or removal of product packaging		
	1 ea	1 year parts & labor warranty, standard		
	1 ea	Natural gas		
			ITEM TOTAL:	\$7,868.91
6	2 ea	GAS CONNECTOR HOSE KIT / ASSEMBLY Klinger's Trading Model No. GH75KIT48 Easyflex® Commercial Gas Connector Kit, 3/4" inside dia., includes: 48" long PVC-coated, non-flammable braided stainless steel hose with 360° rotational ends, quick disconnect, restraining cable, full port valve & (2) 90° elbows, cCSAus (NET price) (tariff exempt)	\$149.00	\$298.00
				
			ITEM TOTAL:	\$298.00

Restaurant Source & Supply

04/24/2026

Subtotal	\$33,160.17
Total	\$33,160.17

All Electrical, Plumbing, And Installs To Be Done By Others
All Electrical Gas & Plumbing Hooks Up To Be Done By Others.
Returned Or Canceled Items May Be Subject To 10% Restock Fees

Signed Quoted With Pay At Delivery Terms May Incur Restock Fees If Cancellation Occurs

Acceptance: _____ Date: _____

Printed Name: _____

Project Grand Total: \$33,160.17

OVENS

VULCAN**VC55G SERIES
DOUBLE DECK GAS CONVECTION OVEN
WITH REMOVABLE DOORS**

Model VC55GD
Shown with optional casters

**SPECIFICATIONS**

Double section gas convection oven, Vulcan Model No. VC55GD. Stainless steel front, sides, top and legs. Independently operated stainless steel doors with double pane windows. Non-sag insulation applied to the top, rear, sides, bottom and doors. Porcelain enamel on steel oven interiors measures 29"w x 22¹/₈"d x 20"h. One interior oven light per section. Five nickel plated oven racks per section measure 28³/₄" x 20¹/₂" with grab-and-go front cut out. Eleven position nickel plated rack guides with positive rack stops. One 50,000 BTU/hr. burner per section. 100,000 total BTU/hr. Electronic spark igniters. Furnished with a two speed 1/2 H.P. oven blower-motor per section. Oven cool switch for rapid cool down. 120 volt, 60 Hz, 1 ph power supply required. 6' cord and plug. 7.7 amps total draw per section.

Exterior Dimensions:

40"w x 40"d (includes motor & door handles) 37¹/₄"d (includes motor only) x 68³/₄"h on 8" legs.

CSA design certified. NSF listed.

**SPECIFY TYPE OF GAS WHEN ORDERING.
SPECIFY ALTITUDE WHEN ABOVE 2,000 FT.**

- VC55GD** Solid state temperature dial controls adjust from 150° to 500°F with digital display enhancement. 5-hour timer with audible alarm.

STANDARD FEATURES

- Independently operated lift-off stainless steel doors with double pane windows.
- On-board diagnostics for easy servicing
- Stainless steel front, sides and top.
- Five nickel plated grab-and-go oven racks with eleven rack positions.
- Painted legs.
- 5-hour timer with digital display enhancement.
- Cool-to-the-touch handles.
- 50,000 BTU/hr. burner.
- Electronic spark igniter.
- 1/2 H.P. two speed oven blower-motor. 120/60/1 with 6' cord and plug. 7.7 amps total draw.
- Oven cool switch for rapid cool down.
- Porcelain enamel on steel oven interior.
- 3/4" rear gas connection with combination gas valve / pressure regulator and safety solenoid system.
- One year limited parts and labor warranty.
- Three year limited warranty on doors.

OPTIONS

- Stainless steel legs.
- Casters.
- Second year extended limited parts and labor warranty.

ACCESSORIES

- Extra oven rack(s).
- Rack hanger.
- Stainless steel drip pan.
- Flexible gas hose with quick disconnect and restraining device. Consult price book for available sizes.
- Down draft flue diverter for direct vent connection.

VULCAN

a division of ITW Food Equipment Group LLC

P.O. Box 696 ■ Louisville, KY 40201 ■ Toll-free: 1-800-814-2028 ■ Local: 502-778-2791 ■ Quote & Order Fax: 1-800-444-0602

O V E N S



VC55G SERIES
DOUBLE DECK GAS CONVECTION OVEN
WITH REMOVABLE DOORS

INSTALLATION INSTRUCTIONS

1. A combination gas valve/pressure regulator and safety solenoid system is included in this unit. Natural gas is 5.0" W.C., Propane gas is 10.0" W.C.
2. An adequate ventilation system is required for commercial cooking equipment. Information may be obtained by writing to the National Fire Protection Association, Batterymarch Park, Quincy, MA 02289. When writing, refer to NFPA No. 96.
3. These units are manufactured for installation in accordance with ANSZ223.1 (latest edition), National Fuel Gas Code. Copies may be obtained from American Gas Association Inc.,

Accredited Standards Committee Z223, 400 N. Capitol St. NW, Washington, DC 20001 or the Secretary Standards Council, NFPA, 1 Batterymarch Park, Quincy, MA 02169-7471.

4. Clearances:

Combustible	Non-combustible
Rear	0"
Right Side	2"
Left Side	1"
5. This appliance is manufactured for commercial installation only and is not intended for home use.

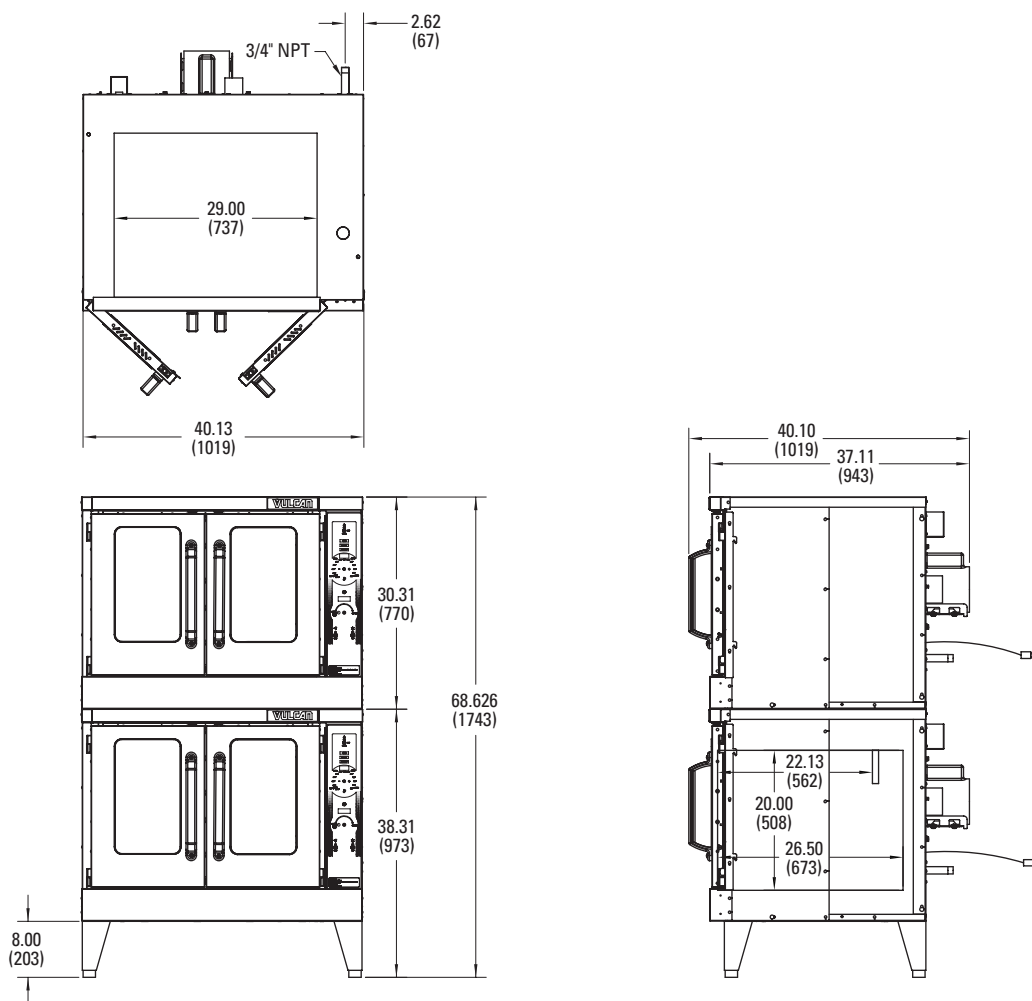

MODEL NO.	WIDTH	DEPTH (INCLUDES HANDLES)	HEIGHT	BTU/HR. PER OVEN	TOTAL BTU/HR.	ELECTRICAL	WEIGHT			
							WITH SKID & PACKAGING		WITHOUT SKID & PACKAGING	
							LBS.	KG	LBS.	KG
VC55G	40"	40"	68¾"	50,000	100,000	120/60/1	778	352	666	302



a division of ITW Food Equipment Group LLC

P.O. Box 696 ■ Louisville, KY 40201 ■ Toll-free: 1-800-814-2028 ■ Local: 502-778-2791 ■ Quote & Order Fax: 1-800-444-0602

NOTE: In line with its policy to continually improve its products, Vulcan reserves the right to change materials and specifications without notice.

COMMERCIAL GAS CONNECTOR KIT

Easyflex's Gas Connector Kit features a PVC-coated, non-flammable gas hose with a stainless steel braid. It also has 360° rotational ends allowing for flexible installation and maximum protection to the hose. Included in the kit are a quick disconnect, restraining cable, full port valve, and 2 elbows. Customized kits are also available upon request.



Quick Disconnect



Restraining Cable

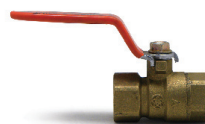

Full Port Valve



Elbow

Contents of Kits

Kit #	BJ Series Hose	Quick Disconnect	Swivel	Elbow	Full Port Valve	Restraining Cable
Kit 1	1	1	0	2	1	1

"BJ" Series Hose Sizes and Kit Model Numbers

BJ Hose Size	36" L	48" L
1/2" ID, 5/8" OD	GH50KIT36 (EFGC-012-FS-K1-36)	GH50KIT48 (EFGC-012-FS-K1-48)
3/4" ID, 1" OD	GH75KIT36 (EFGC-034-FS-K1-36)	GH75KIT48 (EFGC-034-FS-K1-48)
1" ID, 1-1/4" OD	GH100KIT36 (EFGC-100-FS-K1-36)	GH100KIT48 (EFGC-100-FS-K1-48)

"BJ" Series Hose Specifications

ID	BJ Hose Part #	Fittings	Lengths
1/2"	EFGC-012-BJ-1010	1/2" MIP x 1/2" MIP	24", 36", 48", 60", 72"
3/4"	EFGC-034-BJ-1414	3/4" MIP x 3/4" MIP	
1"	EFGC-010-BJ-1616	1" MIP x 1" MIP	

Tube & Braid Material	Stainless Steel 304 (ASTM A240)
Coating Material	Non-Flammable, Yellow PVC
Fittings Material	Zinc-Plated Steel S45C
Quick Disconnect Material	Brass
Max. Operating Pressure	1/2 psi

"BJ" Series Hose Minimum Flow Capacity

Straight Length Capacity (BTU/Hr., 0.64 Sp Gr., 1,000 BTU per cubic ft. at 0.5 inch W.C. pressure drop)

Series	ID (OD)	12"	18"	24"	30"	36"	48"	60"	72"
012	1/2" (5/8")	180,000	164,200	150,000	136,000	125,000	106,000	93,200	86,000
034	3/4" (1")	-	-	290,900	270,500	255,900	215,900	197,400	173,900
010	1" (1-1/4")	-	-	581,800	545,200	515,900	442,700	398,900	347,300

The above flow capacities are the minimum performance requirement EASYFLEX gas connectors exceed these minimum flow capacities requirements.

Design Certifications & Approvals

- Connectors for Movable (Commercial) Gas Appliances - ANSI Z21.69/CSA 6.16
- Quick Disconnect for Gas Appliances - ANSI Z21.41/CSA 6.9
- Manual Gas Valves for Appliances - ANSI Z21.15/CSA 9.1
- Swivel - UL 567_Pipe connection fittings for flammable and combustible liquids including LP gas. ANSI Z223.1/NFPA 54 National Gas Fuel Code. Cannot be used in temperatures below 32°F. For indoor use only.
- All movable (commercial) gas equipment must be secured with a restraining cable.



Job Name:
Job Location:
Submittal Date:
Engineer/Architect:
Wholesaler:
Contractor:

Easyflex Gas Connector Kit Distributed by:

3009 Bankers Industrial Drive
Atlanta, GA 30360
770 246 6006
www.klingerstrading.com



VC44G SERIES

Double Deck Gas Convection Ovens



SELL SHEET

Model VC44GD

Shown on optional casters



SPECIFIER STATEMENT

Double section gas convection oven, Vulcan Model No. (VC44GD) (VC44GC). Stainless steel front, sides, top and legs. Independently operated stainless steel doors with double pane windows. Non-sag insulation applied to the top, rear, sides, bottom and doors. Porcelain enamel on steel oven interiors measures 29" w x 22½" d x 20" h. Two interior oven lights per section. Five nickel plated oven racks per section measure 28¾" x 20½". Eleven position nickel plated rack guides with positive rack stops. One 50,000 BTU/hr. burner per section. 100,000 total BTU/hr. Electronic spark igniters. Furnished with a two speed ½ H.P. oven blower-motor per section. Oven cool switch for rapid cool down. 120 volt, 60 Hz, 1 ph power supply required. 6' cord and plug. 7.7 amps total draw per section.

Exterior Dimensions:

40¼" W x 40" D (includes motor & door handles)

40¼" W x 37¾" D (includes motor only)

70" H on 8" legs

CSA design certified. NSF listed.

Specify type of gas when ordering.

Specify altitude when above 2,000 FT.

Project _____

AIA # _____ SIS # _____

Item # _____ Quantity _____ C.S.I. Section 114000

MODELS

- VC44GD** Solid state temperature controls adjust from 150° to 500°F. 60 minute timer with audible alarm.
- VC44GC** Computer controls with digital time and temperature readouts. 99-hour timer with audible alarm. Roast and Hold cycle. One hundred programmable menu selections. Shelf I.D. programming.

Double deck ovens are supplied as separate units with a stacking kit.

STANDARD FEATURES

- Stainless steel front, sides, top and legs
- Independently operated stainless steel doors with double pane windows
- 50,000 BTU/hr. burner per section, 100,000 BTU/hr. total
- Electronic spark igniters
- ½ H.P. two speed oven blower-motor. 120/60/1 with 6' cord and plug; 7.7 amps per section; 15.4 amps total draw
- Oven cool switch for rapid cool down
- Porcelain enamel on steel oven interior
- Five nickel plated grab-and-go oven racks with eleven rack positions per section (10 total racks)
- ¾" rear gas connection with combination gas pressure regulator and safety solenoid system
- One year limited parts and labor warranty

OPTIONS

- Kosher friendly control package
- Complete prison package
 - Security screws only
- 208V or 240V, 60 Hz, 1 ph, two speed, ½ H.P. blower motor; 208V, 4.2 amps; 240V, 3.6 amps
- Casters
- Simultaneous chain driven doors
- Control panel mounted on left side of oven
- Stainless steel rear enclosure
- Second year extended limited parts and labor warranty

ACCESSORIES (PACKAGED AND SOLD SEPARATELY)

- Extra oven rack(s)
- Rack hanger(s)
- Stainless steel drip pan
- Flexible gas hose with quick disconnect and restraining device; consult price book for available sizes
- Down draft flue diverter for direct vent connection

VC44G SERIES – Double Deck Gas Convection Ovens

Approved by _____ Date _____ Approved by _____ Date _____



VC44G SERIES

Double Deck Gas Convection Ovens

INSTALLATION INSTRUCTIONS

1. A combination gas pressure regulator and safety solenoid valve system is included in this unit. Natural gas is 5.0" W.C., Propane gas is 10.0" W.C.
2. An adequate ventilation system is required for commercial cooking equipment. Information may be obtained by visiting the National Fire Protection Association website at <https://www.nfpa.org/>. Refer to NFPA No. 96.
3. These units are manufactured for installation in accordance with ANSZ223.1A (latest edition), National Fuel Gas Code. Information may be obtained from The American Gas Association website at <https://www.aga.org/>.

4. Clearances:

	Combustible	Non-combustible
Rear	0"	0"
Right Side	2"	0"
Left Side	1"	0"
5. This appliance is manufactured for commercial installation only and is not intended for home use.
6. The installation location should not experience temperatures below -20°C (-4°F).

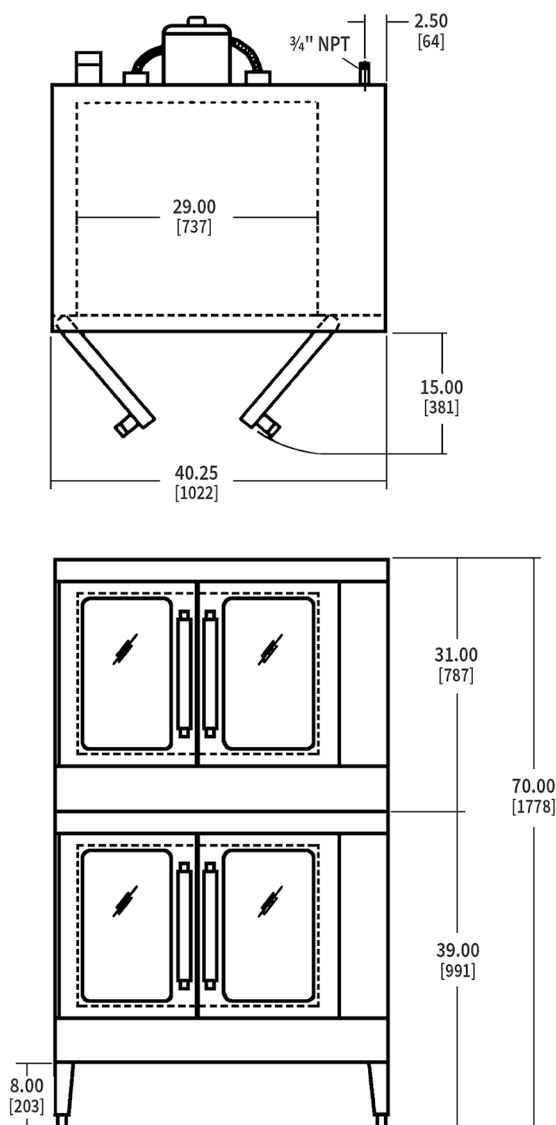

CAD and/or Revit Files Available

INSTALLATION MANUAL

40¼" W x 41⅛" D (includes motor & door handles)
 40¼" W x 37¾" D (includes motor only)
 70" H on 8" legs

Oven interior: 29" W x 22⅞" D x 20" H

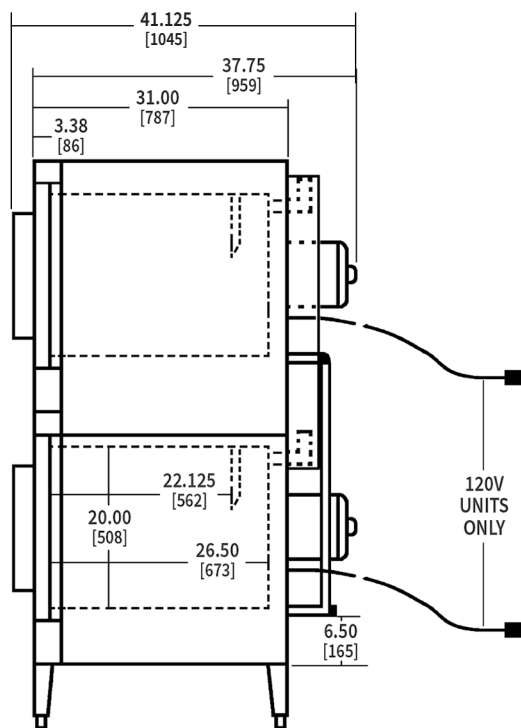

Model	Width	Depth w/handles	Height	Per Oven BTU/hr.	Total BTU/hr.	Electrical	Weight
VC44G	40¼"	41⅛"	70"	50,000	100,000	120/60/1	820 lbs (372 KG) without skids/packaging 928 lbs (422 KG) with skids/packaging

As continued product improvement is a policy of Vulcan, specifications are subject to change without notice.

COMMERCIAL GAS CONNECTOR KIT

Easyflex's Gas Connector Kit features a PVC-coated, non-flammable gas hose with a stainless steel braid. It also has 360° rotational ends allowing for flexible installation and maximum protection to the hose. Included in the kit are a quick disconnect, restraining cable, full port valve, and 2 elbows. Customized kits are also available upon request.

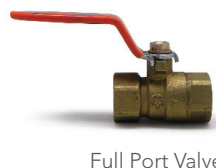

Contents of Kits

Kit #	BJ Series Hose	Quick Disconnect	Swivel	Elbow	Full Port Valve	Restraining Cable
Kit 1	1	1	0	2	1	1

"BJ" Series Hose Sizes and Kit Model Numbers

BJ Hose Size	36" L	48" L
1/2" ID, 5/8" OD	GH50KIT36 (EFGC-012-FS-K1-36)	GH50KIT48 (EFGC-012-FS-K1-48)
3/4" ID, 1" OD	GH75KIT36 (EFGC-034-FS-K1-36)	GH75KIT48 (EFGC-034-FS-K1-48)
1" ID, 1-1/4" OD	GH100KIT36 (EFGC-100-FS-K1-36)	GH100KIT48 (EFGC-100-FS-K1-48)

"BJ" Series Hose Specifications

ID	BJ Hose Part #	Fittings	Lengths
1/2"	EFGC-012-BJ-1010	1/2" MIP x 1/2" MIP	24", 36", 48", 60", 72"
3/4"	EFGC-034-BJ-1414	3/4" MIP x 3/4" MIP	
1"	EFGC-010-BJ-1616	1" MIP x 1" MIP	

Tube & Braid Material	Stainless Steel 304 (ASTM A240)
Coating Material	Non-Flammable, Yellow PVC
Fittings Material	Zinc-Plated Steel S45C
Quick Disconnect Material	Brass
Max. Operating Pressure	1/2 psi

"BJ" Series Hose Minimum Flow Capacity

Straight Length Capacity (BTU/Hr., 0.64 Sp Gr., 1,000 BTU per cubic ft. at 0.5 inch W.C. pressure drop)

Series	ID (OD)	12"	18"	24"	30"	36"	48"	60"	72"
012	1/2" (5/8")	180,000	164,200	150,000	136,000	125,000	106,000	93,200	86,000
034	3/4" (1")	-	-	290,900	270,500	255,900	215,900	197,400	173,900
010	1" (1-1/4")	-	-	581,800	545,200	515,900	442,700	398,900	347,300

The above flow capacities are the minimum performance requirement EASYFLEX gas connectors exceed these minimum flow capacities requirements.

Design Certifications & Approvals

- Connectors for Movable (Commercial) Gas Appliances - ANSI Z21.69/CSA 6.16
- Quick Disconnect for Gas Appliances - ANSI Z21.41/CSA 6.9
- Manual Gas Valves for Appliances - ANSI Z21.15/CSA 9.1
- Swivel - UL 567_Pipe connection fittings for flammable and combustible liquids including LP gas. ANSI Z223.1/NFPA 54 National Gas Fuel Code. Cannot be used in temperatures below 32°F. For indoor use only.
- All movable (commercial) gas equipment must be secured with a restraining cable.



Job Name:
Job Location:
Submittal Date:
Engineer/Architect:
Wholesaler:
Contractor:

Easyflex Gas Connector Kit Distributed by:

Klinger's
TRADING, INC.

3009 Bankers Industrial Drive
Atlanta, GA 30360
770 246 6006
www.klingerstrading.com

Item # _____
 Qty # _____
 Model # _____
 Project # _____



DUKERS
 Quality Commercial Refrigeration



CONVECTION OVEN

(Double Layer)DCCOG2

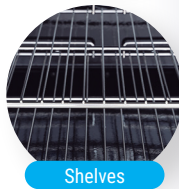

PRODUCT DESCRIPTION

- Elegant stainless steel exterior for easy cleaning.
- Durable double-pane glass with independent doors.
- Electronic spark ignition with an automatic pilot system with safety shut off.
- Oven temperature range between 175°F to 500°F
- Two speed-fan with adjustable cool down mode.
- Includes Ten adjustable shelves.
- Double-stacking options to optimize your kitchen space



HIGH QUALITY STAINLESS STEEL & ROBUST DESIGN

GAS RANGE MODEL	DIMENSION		
	Width	Depth	Height
DCCOG2	38 in	39 3/4 in	68 1/2 in



Los Angeles | San Francisco | Dallas
 Houston | Florida | Chicago | New Jersey

DETAILS & SPECIFICATIONS

DCCOG2

Front View

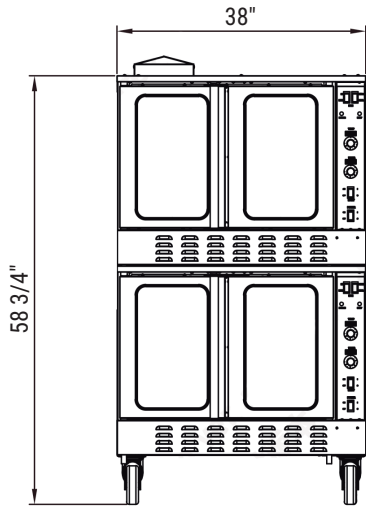

DCCOG2

GAS SOURCE	LGP/NG
POWER (W)	887 x 2
BURNER	3 x 2 count
SINGLE BURNER	18000 BTU/H
TOTAL OUTPUT	54000 x 2 BTU/H
GAS PRESSURE	NG: 4 "WC LGP: 10 "WC
NOZZLE CONTAINER	55/45
FITMENT	18
VOLTAGE	110 V
NE-MA(Plug Type)	5-15P
CURRENT	8 A x 2

Top View

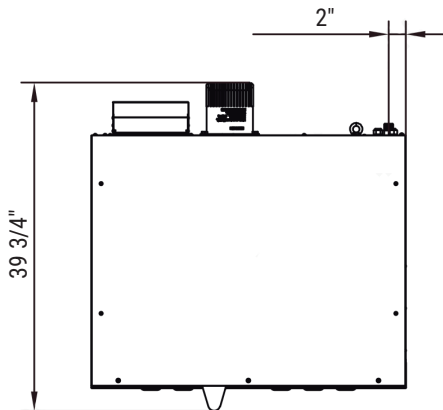

Side View

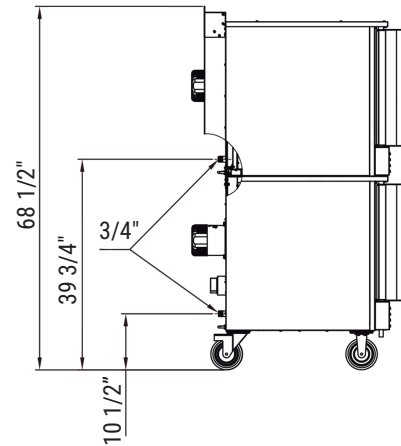

Model	Packaging Dimensions (inches)			Net Weight (lbs)	Ship Weight (lbs)
	W	D	H		
DCCOG2	41 7/10"	45 3/5"	75 1/2"	1000	1100



Los Angeles | San Francisco | Dallas
Houston | Florida | Chicago | New Jersey

Harleton ISD

Restaurant Source & Supply

1-800-931-8628

@ info@dukersusa.com

www.DukersUSA.com

Page: 11

COMMERCIAL GAS CONNECTOR KIT

Easyflex's Gas Connector Kit features a PVC-coated, non-flammable gas hose with a stainless steel braid. It also has 360° rotational ends allowing for flexible installation and maximum protection to the hose. Included in the kit are a quick disconnect, restraining cable, full port valve, and 2 elbows. Customized kits are also available upon request.



Quick Disconnect



Restraining Cable

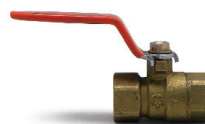

Full Port Valve



Elbow

Contents of Kits

Kit #	BJ Series Hose	Quick Disconnect	Swivel	Elbow	Full Port Valve	Restraining Cable
Kit 1	1	1	0	2	1	1

"BJ" Series Hose Sizes and Kit Model Numbers

BJ Hose Size	36" L	48" L
1/2" ID, 5/8" OD	GH50KIT36 (EFGC-012-FS-K1-36)	GH50KIT48 (EFGC-012-FS-K1-48)
3/4" ID, 1" OD	GH75KIT36 (EFGC-034-FS-K1-36)	GH75KIT48 (EFGC-034-FS-K1-48)
1" ID, 1-1/4" OD	GH100KIT36 (EFGC-100-FS-K1-36)	GH100KIT48 (EFGC-100-FS-K1-48)

"BJ" Series Hose Specifications

ID	BJ Hose Part #	Fittings	Lengths
1/2"	EFGC-012-BJ-1010	1/2" MIP x 1/2" MIP	24", 36", 48", 60", 72"
3/4"	EFGC-034-BJ-1414	3/4" MIP x 3/4" MIP	
1"	EFGC-010-BJ-1616	1" MIP x 1" MIP	

Tube & Braid Material	Stainless Steel 304 (ASTM A240)
Coating Material	Non-Flammable, Yellow PVC
Fittings Material	Zinc-Plated Steel S45C
Quick Disconnect Material	Brass
Max. Operating Pressure	1/2 psi

"BJ" Series Hose Minimum Flow Capacity

Straight Length Capacity (BTU/Hr., 0.64 Sp Gr., 1,000 BTU per cubic ft. at 0.5 inch W.C. pressure drop)

Series	ID (OD)	12"	18"	24"	30"	36"	48"	60"	72"
012	1/2" (5/8")	180,000	164,200	150,000	136,000	125,000	106,000	93,200	86,000
034	3/4" (1")	-	-	290,900	270,500	255,900	215,900	197,400	173,900
010	1" (1-1/4")	-	-	581,800	545,200	515,900	442,700	398,900	347,300

The above flow capacities are the minimum performance requirement EASYFLEX gas connectors exceed these minimum flow capacities requirements.

Design Certifications & Approvals

- Connectors for Movable (Commercial) Gas Appliances - ANSI Z21.69/CSA 6.16
- Quick Disconnect for Gas Appliances - ANSI Z21.41/CSA 6.9
- Manual Gas Valves for Appliances - ANSI Z21.15/CSA 9.1
- Swivel - UL 567_Pipe connection fittings for flammable and combustible liquids including LP gas. ANSI Z223.1/NFPA 54 National Gas Fuel Code. Cannot be used in temperatures below 32°F. For indoor use only.
- All movable (commercial) gas equipment must be secured with a restraining cable.



Job Name:
Job Location:
Submittal Date:
Engineer/Architect:
Wholesaler:
Contractor:

Easyflex Gas Connector Kit Distributed by:



3009 Bankers Industrial Drive
Atlanta, GA 30360
770 246 6006
www.klingerstrading.com

**Board Resolution Extending Depository Contract for Funds
Of Independent School Districts Under Texas Education Code,
Chapter 45, Subchapter G, School District Depositories**

Be it Resolved by the Harleton Independent School District that:
Board of Trustees

First National Bank of Hughes Springs Bank, Depository, located at Harrison County,
Name of Depository Bank *Name of County*

State of Texas, being a bank as that term is defined in section 45.201 of the Texas Education Code, and

Harleton Independent School District (CDN: 102-905) agree to extend for an additional
Name of District

two-year term from 09-01-2025 through 08-31-2027, the existing terms and conditions for banking services
and rates previously agreed to in the Depository Contract in effect from 09-01-2021 through 08-31-2023.

This agreement to extend is allowed under Texas Education Code, Section 45.205 Subchapter G.

AGREED AND ACCEPTED on behalf of Harleton Independent School District
Name of District

this the 19th day of May, 2016.

Signature of President of School Board

AGREED AND ACCEPTED on behalf of Depository this the _____ day of _____, _____.

First National Bank of Hughes Springs
Typed Name of Depository

Signature of Authorized Bank Officer

Title of Authorized Bank Officer

ACKNOWLEDGMENT

STATE OF TEXAS
COUNTY OF _____

Before me, the undersigned authority in and for said county and state, on this day personally appeared
_____ known to me to be the person whose name is subscribed to the foregoing

Authorized Bank Officer
instrument on behalf of the Depository named therein, and known to me to be an officer authorized to
execute the foregoing instrument on behalf of said Depository, and acknowledged to me that (s)he executed
the same as the act and deed of said Depository, for the purpose therein expressed and in the capacity therein
stated.

Given under my hand and seal of office this the _____ day of _____, _____.

(SEAL)

Signature of Notary

Notary Public in and for _____ County, Texas

School Enrollment

001 HARLETON HIGH SCHOOL

Grade	American Ind		Asian		Black		Nat Hawaiian		White		Hispanic/Lat Eth		Multi-Race		Total		Total
	Male	Female	Male	Female	Male	Female	Male	Female	Male	Female	Male	Female	Male	Female	Male	Female	
09	0	0	0	0	0	0	0	0	20	17	1	1	0	0	21	18	39
10	0	0	0	0	1	0	0	0	21	24	4	6	2	0	28	30	58
11	0	0	0	0	1	0	0	0	27	23	1	3	1	1	30	27	57
12	0	0	0	0	1	0	0	0	17	17	2	6	2	0	22	23	45
TOTAL	0	0	0	0	3	0	0	0	85	81	8	16	5	1	101	98	199

School Enrollment

041 HARLETON JR HIGH SCHOOL

Grade	American Ind		Asian		Black		Nat Hawaiian		White		Hispanic/Lat Eth		Multi-Race		Total		Total
	Male	Female	Male	Female	Male	Female	Male	Female	Male	Female	Male	Female	Male	Female	Male	Female	
06	0	0	0	0	0	1	0	0	17	20	6	2	0	1	23	24	47
07	0	0	1	0	0	0	0	0	31	24	1	2	1	2	34	28	62
08	0	0	0	0	0	1	0	0	28	28	0	5	1	1	29	35	64
TOTAL	0	0	1	0	0	2	0	0	76	72	7	9	2	4	86	87	173

School Enrollment

101 HARLETON ELEMENTARY SCHOOL

Grade	American Ind		Asian		Black		Nat Hawaiian		White		Hispanic/Lat Eth		Multi-Race		Total		Total
	Male	Female	Male	Female	Male	Female	Male	Female	Male	Female	Male	Female	Male	Female	Male	Female	
01	0	0	0	0	0	0	0	0	16	18	3	2	0	5	19	25	44
02	0	0	0	0	1	0	0	0	22	26	1	0	2	4	26	30	56
03	0	0	0	0	0	0	0	0	21	23	0	2	3	2	24	27	51
04	0	0	0	0	0	0	0	0	17	33	2	1	1	0	20	34	54
05	0	0	0	0	0	1	0	0	28	23	2	1	1	3	31	28	59
KG	0	0	0	0	0	0	0	0	29	18	5	2	5	1	39	21	60
PK	0	0	0	0	2	1	0	0	7	9	0	1	0	0	9	11	20
TOTAL	0	0	0	0	3	2	0	0	140	150	13	9	12	15	168	176	344

School Enrollment

999 Non-Enrolled

Grade	American Ind		Asian		Black		Nat Hawaiian		White		Hispanic/Lat Eth		Multi-Race		Total		Total
	Male	Female	Male	Female	Male	Female	Male	Female	Male	Female	Male	Female	Male	Female	Male	Female	
05	0	0	0	0	0	0	0	0	0	1	0	0	0	0	0	1	1
TOTAL	0	0	0	0	0	0	0	0	0	1	0	0	0	0	0	1	1

Totals for All Schools

Grade	American Ind		Asian		Black		Nat Hawaiian		White		Hispanic/Lat Eth		Multi-Race		Total		Total
	Male	Female	Male	Female	Male	Female	Male	Female	Male	Female	Male	Female	Male	Female	Male	Female	
01	0	0	0	0	0	0	0	0	16	18	3	2	0	5	19	25	44
02	0	0	0	0	1	0	0	0	22	26	1	0	2	4	26	30	56
03	0	0	0	0	0	0	0	0	21	23	0	2	3	2	24	27	51
04	0	0	0	0	0	0	0	0	17	33	2	1	1	0	20	34	54
05	0	0	0	0	0	1	0	0	28	24	2	1	1	3	31	29	60
06	0	0	0	0	0	1	0	0	17	20	6	2	0	1	23	24	47
07	0	0	1	0	0	0	0	0	31	24	1	2	1	2	34	28	62
08	0	0	0	0	0	1	0	0	28	28	0	5	1	1	29	35	64
09	0	0	0	0	0	0	0	0	20	17	1	1	0	0	21	18	39

Totals for All Schools

Grade	American Ind		Asian		Black		Nat Hawaiian		White		Hisp/Lat Eth		Multi-Race		Total		Total	
	Male	Female	Male	Female	Male	Female	Male	Female	Male	Female	Male	Female	Male	Female	Male	Female	Male	Female
10	0	0	0	0	1	0	0	0	21	24	4	6	2	0	28	30	58	
11	0	0	0	0	1	0	0	0	27	23	1	3	1	1	30	27	57	
12	0	0	0	0	1	0	0	0	17	17	2	6	2	0	22	23	45	
KG	0	0	0	0	0	0	0	0	29	18	5	2	5	1	39	21	60	
PK	0	0	0	0	2	1	0	0	7	9	0	1	0	0	9	11	20	
TOTAL	0	0	1	0	6	4	0	0	301	304	28	34	19	20	355	362	717	

***** End of report *****