

**LIVONIA PUBLIC SCHOOLS
BOARD OF EDUCATION**

**Committee of the Whole Meeting
November 10, 2025 - 6:30 PM
Board Room
15125 Farmington Road
Livonia, Michigan 48154**

AGENDA

- I. AUDIENCE COMMUNICATIONS**
- II. COMMITTEE OF THE WHOLE**
Bradford, Chair; Acosta; Bradford; Burton; Frank; Jarvis; Johnson;
MacFarland
- III. OPERATIONS COMMITTEE**
Burton, Chair; Johnson; MacFarland
 - A. 2026 Bond Renovation Bid Results** 2
W. Green
 - B. Purchase of Bulk Salt** 36
W. Green
 - C. Purchase of Hydration Stations** 43
W. Green
 - D. Purchase of Lockdown Shades** 55
W. Green
 - E. Purchase of Physical Education and Field House Fans** 84
W. Green
 - F. Purchase of District Generator for Central Office** 101
Complex
W. Green
- IV. FINANCE COMMITTEE**
Johnson, Chair; Acosta; Jarvis
- V. DIVISION OF INSTRUCTION COMMITTEE**
Acosta, Chair; Frank; MacFarland
- VI. BOARD POLICY COMMITTEE**
Frank, Chair; Burton; Jarvis
 - A. Board Policy and Administrative Procedures: JD -** 107
Student Code of Conduct
J. Keatts, K. Etue
 - B. Board Policy and Administrative Procedures JAB —** 113
Nondiscrimination on the Basis of Disability - Section
504
M. Sprow
- VII. HUMAN RESOURCES COMMITTEE**
MacFarland, Chair; Burton; Johnson
- VIII. LEGISLATIVE COMMITTEE**
Jarvis, Chair; Acosta; Frank



Date: November 7, 2025

To: Andrea Oquist, Superintendent

From: William Green, Assistant Superintendent of Operations and District Services

Re: 2026 Bond Renovation Bid Results

William Green, Assistant Superintendent of Operations and District Services and Brian Weber, Plante Moran Realpoint would like an opportunity to share with the Board of Education the bid results for the summer 2026 Renovation projects at Garfield, Niji-Iro, and Webster schools.

Background:

These three buildings represent the final phase of the 2021 District's bond-funded renovation efforts. The planned updates will enhance learning environments and improve space utilization for both staff and students. Bids were due and publicly opened on October 27, 2025. Following the bid opening, the Bond Team conducted a thorough review of all submissions and held interviews with potential contractors to ensure alignment with project goals and standards.

Recommendation:

Based on the evaluation process, the Bond Team recommends proceeding with the bidders outlined in Clark Construction's recommendation letter. This recommendation is supported by both Plante Moran Realpoint, the District's owner's representative, and Clark Construction, the construction manager. The total project cost for summer 2026 hard construction is \$8,761,728, with a contingency of \$613,321 and fees of \$543,178, resulting in a total project cost of \$9,918,227.

Please add this request to the agenda for the Committee of the Whole, Monday, November 10, 2025.

Thank you.

Attachments

WG/AS

c: Board of Education

November 05, 2025

Mr. Bill Green
Asst. Superintendent of District Services
Livonia Public Schools
15125 Farmington Road
Livonia, MI 48154

RE: 2021 Bond Program
Contract Award Recommendation for Construction Bids
Phase 5 – Bid Pack 1: 2026 Summer Renovations
Garfield / Webster / Niji-Iro

Dear Mr. Green:

This letter transmits an update from Plante Moran Realpoint (PMR) as it relates to the assignment to assist and advise Livonia Public Schools (LPS) in its selection of Prime Contractors for the Project listed above. This update represents the mutual efforts of PMR, Clark Construction Co., French Associates, and LPS administration and staff (the Bond Team) to present a framework in order to identify, evaluate and recommend Prime Contractors for this Project.

On October 03, 2025, Construction Documents were formally issued and made available. An advertisement for bids was published in a local newspaper, posted to the required State of Michigan websites and forwarded to multiple construction bidding websites.

On October 27, 2025, 138 bid proposals were received, and over the next several days were reviewed to determine the budget implications. Interviews were also held during this time and were attended by various members of the Bond Team.

Upon completion of the interviews, and after subsequent clarifications and discussions, the Bond Team is recommending the firms listed in Clark Construction Co.'s Award Recommendation Letter dated November 04, 2025, for contract award.

The recommendation includes the acceptance of multiple Alternates as further detailed in Clark's recommendation letter.

Including hard construction of \$8,761,728, CM general conditions, fees and staffing of \$543,178, and construction contingency of \$613,321, this Project award recommendation equals \$9,918,227.

For the Prime Contractors, the costs for this work will be detailed in AIA Contract A132 – 2019 Standard Form of Agreements between Owner and Contractor pending final review and approval of terms by district legal counsel.

The Project Team is available at the Board's convenience to answer any questions regarding bidding, the proposals, interview process, or the recommendations of the Bond Team. Please direct all questions through me via email at brian.weber@plantemoran.com.

Sincerely,

PLANTE MORAN REALPOINT



Brian Weber
Senior Vice President

Enclosures: Budget Summary
Clark Construction Co. Award Recommendation Letter
Bid Tabulations



PHASE 5 - BID PACK 1: 2026 SUMMER RENOVATIONS
BUDGET SUMMARY

	Hard Construction		
Building	Budget	Actual	Variance
Multiple - Listed below	\$ 8,900,000	\$ 8,761,728	\$ 138,272
Totals	\$ 8,900,000	\$ 8,761,728	\$ 138,272

	CM Fees/Costs		
	Budget	Actual	Variance
Reimbursables	Included within the CM Contract		
General Conditions (2%)	\$ 280,000	\$ 175,234	\$ 104,766
CM Fee (2%)	\$ 280,000	\$ 187,501	\$ 92,499
CM Staffing	\$ 180,000	\$ 180,443	\$ (443)
Totals	\$ 740,000	\$ 543,178	\$ 196,822

	Construction Contingency (7%)		
	Budget	Actual	Variance
	\$ 623,000	\$ 613,321	\$ 9,679
Totals	\$ 623,000	\$ 613,321	\$ 9,679

	Total Project Costs		
	Budget	Actual	Variance
	\$ 10,263,000	\$ 9,918,227	\$ 344,773
Totals	\$ 10,263,000	\$ 9,918,227	\$ 344,773 *

* The budget savings will be reallocated to the Owner's Contingency within the Bond Program

Schools Included:

- Garfield
- Niji-Iro
- Webster



Headquarters
 3535 Moores River Drive
 Lansing, MI 48911
 517.372.0940 phone | 517.372.0668 fax
www.clarkcc.com

Southeast MI Office
 2660 Superior Court
 Auburn Hills, MI 48326
 248.286.1000 phone

Northern MI Office
 3432 US 23 South
 Alpena, MI 49707
 989.278.2272 phone

Livonia Public Schools – Phase # 5 -Bid Package No. 1 Summer 2026 Renovations

November 4, 2025

Mr. William Green - Asst. Superintendent of District Services
 Livonia Public Schools
 15125 Farmington Rd
 Livonia, MI 48154

Re: Livonia Public Schools – 2021 Bond Program
 Contract Award Recommendations 21-2867- Phase # 5 -Bid Package No. 1 Summer 2026
 Renovations

Dear Mr. Green,

Bids for Summer 2026 Renovations were received on October 27, 2025. Bids were based on plans and specifications issued by French Associates dated September 22, 2025 including Addendums 1, 2 & 3. Clark Construction Company, French Associates, Unified Building System Engineering, C.i.i. Food Service Design, Plante Moran Realpoint and Livonia Public Schools have conducted post bid interview meetings with the low qualified recommended bidders. Bidders have submitted information in Clark Construction's pre-qualification database. The pre-qualification database includes trade contractors past financials, bonding capacity, safety rating, labor capacity during the project schedule and reference calls regarding past projects. Each Contractor has committed to meeting the requirements in the Contract Documents.

In addition to the direct Trade Contractor costs, Clark Construction Company recommends including a Construction Contingency budget of 7% for any unforeseen issues and a General Condition budget of 2% related to items such as building permits, security and safety requirements, temporary utilities, etc. No costs will be committed without prior approval of the District Administration for each item. Clark Construction, Construction Manager's Fee of 2% based on the Trade Contract cost and Construction Contingency. Any unused Contingency and associated CM Fee's will be returned to Livonia Public Schools.

Clark Construction Company recommends Livonia Public Schools enter contracts with each of the Trade Contractors for the listed amounts below. The recommended Trade Contractors provided the lowest qualified bid for the work.



Michigan's First
 Platinum Contractor

2017, 2015 & 2013 AGC
 National Safety
 Excellence Award

An Equal Opportunity
 Employer



Headquarters
 3535 Moores River Drive
 Lansing, MI 48911
 517.372.0940 phone | 517.372.0668 fax
www.clarkcc.com

Southeast MI Office
 2660 Superior Court
 Auburn Hills, MI 48326
 248.286.1000 phone

Northern MI Office
 3432 US 23 South
 Alpena, MI 49707
 989.278.2272 phone

PHASE # 5 - BID PACK #1 - 2026 Summer Renovations – AWARD

RECOMMENDATIONS

Listed below are the Bidders for which we recommend Board of Education approval to issue contracts and enclosed are Bid tabulations for the recommended Bid Categories of Work.

Bid Category & Description	Contractor	Base Bid Amount	Accepted Bid Alternates	Trade Total with Alternates
01A: Final Cleaning	NA - Bid Allowance	\$75,000.00		\$75,000.00
02A1: Demolition (Garfield)	Blue Star Demolition Inc.	\$83,500.00		\$83,500.00
02A2: Demolition (Niji-Iro & Webster)	KM Construction Inc.	\$169,000.00		\$169,000.00
03A: Concrete Flatwork	McCarthy Construction	\$110,443.00		\$110,443.00
04A: Masonry	Boss Construction Inc.	\$182,000.00		\$182,000.00
05A: Structural Steel	Suburban Fabrication	\$114,230.00		\$114,230.00
06A1: General Trades (Garfield)	National Specialty Contractors	\$399,000.00		\$399,000.00
06A2: General Trades (Niji-Iro & Webster)	Hicks Construction	\$848,008.00		\$848,008.00
07A: Roofing	JD Candler	\$52,640.00		\$52,640.00
08A: Entrances, Windows, Glass & Glazing	Preferred Glass	\$306,503.00		\$306,503.00
09A1 & A2: Metal Studs, Gypboard, Acoustic Ceilings	Pontiac Ceiling & Partition	\$512,474.00	\$107,579.00	\$607,624.00
09B1: Carpet and Resilient Flooring (Garfield)	Flooring Services	\$69,384.00		\$69,384.00
09B2: Carpet and Resilient Flooring (Niji-Iro & Webster)	Shock Brothers	\$236,850.00		\$236,850.00
09C1: Painting (Garfield)	Conci Painting	\$56,900.00	(\$7,035.00)	\$51,200
09C2: Painting (Niji-Iro & Webster)	Continental Painting	\$148,300.00	\$5,000.00	\$153,300.00
09D: Hard Tile	DF Floor Covering	\$19,393.00		\$19,393.00
011A1 & A2: Food Service Equipment	Great Lake Hotel Supply	\$226,010.00		\$226,010.00
021A: Fire Suppression	Jackson Associates	\$28,160.00	\$44,441.00	\$67,270.00
022A1: Plumbing (Garfield)	CSM Mechanical	\$128,000.00		\$128,000.00
022A2: Plumbing (Niji-Iro & Webster)	A.J. Miller Mechanical	\$227,802.00		\$227,802.00
023A1 & A2: HVAC	De-Cal	\$3,174,100.00		\$3,174,100.00
026A1 & A2 Electrical Systems	Great Lakes Power & Lighting	\$1,402,000.00	\$42,046.00	\$1,439,000.00
Trade Contracts Total:		\$8,569,697.00	\$192,031.00	\$8,761,728.00
Construction Contingency (7%):		\$599,879.00	\$13,442.00	\$613,321.00
Construction Cost Total:		\$9,169,576.00	\$205,473.00	\$9,375,049.00



Michigan's First
Platinum Contractor

2017, 2015 & 2013 AGC
National Safety
Excellence Award

An Equal Opportunity
Employer



Headquarters
 3535 Moores River Drive
 Lansing, MI 48911
 517.372.0940 phone | 517.372.0668 fax
www.clarkcc.com

Southeast MI Office
 2660 Superior Court
 Auburn Hills, MI 48326
 248.286.1000 phone

Northern MI Office
 3432 US 23 South
 Alpena, MI 49707
 989.278.2272 phone

General Conditions (2% X \$8,569,697.00): Trade Costs
 CM Fee (2% X \$9,169,576.00): Trade Costs + Contingency
 2026 Staffing
 Total Clark Contract Amendment

Clark Construction Costs		
\$171,394.00	\$3,840.00	\$175,234.00
\$183,392.00	\$4,109.00	\$187,501.00
\$180,443.00	\$0	\$180,443.00
\$535,229.00	\$7,949.00	\$543,178.00
		\$9,918,227.00

TOTAL AMOUNT OF BOARD APPROVAL

Bid Clarification Notes:

- 07A: \$6,940.00 allowance added to base bid for 360 Mobile Railing due to scope gap.
- 09A1 & A2: \$6,000.00 added to base bid for General Allowance to cover both bid packages.
- 023A1 & A2: \$13,500.00 added to base bid for Mechanical Platform due to scope gap.
- 026A1 & A2: \$15,000.00 allowance added to base bid for unforeseen conditions to cover both bid packages.
- Bid Categories 09A1 & A2, 09C1, 021A, and 026A1 & A2 have alternate costs to account for the 3 added rooms with acoustical spray.

Please contact me with any questions at mmckay@clarkcc.com

Sincerely,

Mike McKay

Digitally signed by Mike McKay
 DN: C=US, E=mmckay@clarkcc.com,
 O=Clark Construction Company,
 OU=Project Manager, CN=Mike McKay
 Date: 2025.11.05 09:12:53-05'00'

Mike McKay
 Clark Construction Company



Michigan's First
 Platinum Contractor

2017, 2015 & 2013 AGC
 National Safety
 Excellence Award

An Equal Opportunity
 Employer

Livonia Public Schools Summer 2026 Bid Tabulation

01A Final Cleaning	11
02A1 Demolition	7
02A2 Demolition	5
03A Concrete	1
04A Masonry	9
05A Structural Steel	3
06A1 General Trades	10
06A2 General Trades	6
07A Roofing	3
08A Glass & Glazing	8
09A1 Carpentry	6
09A2 Carpentry	6
09B1 Carpet & Resilient Flooring	7
09B2 Carpet & Resilient Flooring	7
09C1 Painting	7
09C2 Painting	5
09D Hard Tile	4
011A1 Food Service Equipment	2
011A2 Food Service Equipment	2
021A Fire Suppression	5
022A1 Plumbing	8
022A2 Plumbing	6
023A1 HVAC	4
023A2 HVAC	2
026A1 Electrical	2
026A2 Electrical	3
TOTAL BIDS RECEIVED	138

212867 - Phase #5 - Bid Package #1: Livonia Public Schools - Phase 5 Bid Package 1 - Summer 2026

Prepared by Clark Construction Company - 3535 Moores River Drive, Lansing, MI 48911, United States of America
 Bid Package Lead: Michael Moczy
 moczom@clarkco.com
 Project Location: 15125 Farmington Road,
 Livonia, MI 48154, United States of America

BC-001: Final Cleaning Submitted October 27, 2025	Premier Group Associates LC Submitted by Shelby Hahn	Supra Services Corp Submitted by Aashu Henrique Junior	GD Top Notch Cleaning Service Submitted by GD Top Notch	SmartCrew Cleaning Services Submitted by Carol Stratos	Pro Image Facility Services Submitted by Greg Mekhuson	Good to Go Submitted by Patrick Gallagher	Kessor Enterprises, Ltd. dba Superior Labor Solut Submitted by Ryan Roberts	Mid Mitten Cleaning Services Submitted by Stan Marshall	Limpair Submitted by Estimating Dept	TDT Construction Services Submitted by Tania Thompson	Superior Innovative Solutions Submitted by Jenis
Base Bid	\$14,740	\$17,500	\$19,455	\$25,876	\$28,363	\$40,392	\$61,223	\$62,600	\$73,100	\$78,540	\$191,651
Original Proposal, October 27, 2025	Original Proposal, October 27, 2025	Original Proposal, October 23, 2025	Original Proposal, October 21, 2025	Original Proposal, October 7, 2025	Original Proposal, October 27, 2025	Original Proposal, October 27, 2025	Original Proposal, October 21, 2025	Original Proposal, October 27, 2025	Original Proposal, October 6, 2025	Original Proposal, October 27, 2025	Original Proposal, October 27, 2025
LINE ITEMS	Unit	Unit	Unit	Unit	Unit	Unit	Unit	Unit	Unit	Unit	Unit
Total Cost	Total Cost	Total Cost	Total Cost	Total Cost	Total Cost	Total Cost	Total Cost	Total Cost	Total Cost	Total Cost	Total Cost
Final Cleaning (including bond)	\$14,740	\$17,500	\$19,455	\$25,876	\$28,363	\$40,392	\$61,223	\$62,600	\$73,100	\$78,540	\$191,651
Base Bid Total	\$14,740	\$17,500	\$19,455	\$25,876	\$28,363	\$40,392	\$61,223	\$62,600	\$73,100	\$78,540	\$191,651

BC-002A1: Selective Demolition - Garfield Generated October 27, 2025	Blue Star, Inc. Submitted by Luchrisha Stong	Superior Innovative Solutions Submitted by Wendy Lewis	KM Construction, LLC Submitted by Calvin Saidy	Industrial Demolition Services Submitted by claudell ruffin	DKI, International Inc. Submitted by Fred Yacoub	Christman Constructors, Inc. Submitted by Rachel Hollon	Great Lakes Environmental S Submitted by Ryan Cleary	Great Lakes Construction Ser Submitted by Dan Husek
Base Bid	\$83,500	\$0	\$94,990	\$106,000	\$135,000	\$139,950	\$182,000	\$205,500
	Original Proposal, October 27	Original Proposal, October 27	Revision #1, October 27, 2025	Original Proposal, October 27	Original Proposal, October 27	Original Proposal, October 27	Original Proposal, October 27	Original Proposal, October 23
LINE ITEMS	Unit Total Cost	Unit Total Cost	Unit Total Cost	Unit Total Cost	Unit Total Cost	Unit Total Cost	Unit Total Cost	Unit Total Cost
Selective Demolition - Garfield (Including Bond)								
	\$83,500	\$0	\$94,990	\$106,000	\$135,000	\$139,950	\$182,000	\$205,500

212867 - Phase #5 - Bid Package #1: Livonia Public Schools - Phase 5 Bid Package 1 - Summer 2026

Prepared by Clark Construction Company - 3535 Moores River Drive, Lansing, MI 48911, United States of America

Bid Package Lead: Michael McKay (mmckay@clarkcc.com)

Project Location: 15125 Farmington Road, Livonia, MI 48154, United States of America

BC-002A2: Selective Demolition - Niji Iro & Webster
Generated October 27, 2025

Base Bid

LINE ITEMS

Selective Demolition - Niji Iro & Webster
(Including Bond)

KM Construction, LLC
Submitted by Calvin Saidy

\$169,000

Revision #1, October 27, 2025

Unit	Total Cost
------	------------

\$169,000

DKI, International Inc.
Submitted by Fred Yacoub

\$204,000

Original Proposal, October 27, 2025

Unit	Total Cost
------	------------

\$204,000

Blue Star, Inc.
Submitted by Luchrisha Stong

\$214,000

Original Proposal, October 27, 2025

Unit	Total Cost
------	------------

\$214,000

Industrial Demolition Services
Submitted by Trevette Cochran-Moore

\$285,300

Original Proposal, October 27, 2025

Unit	Total Cost
------	------------

\$285,300

Christman Constructors, Inc.
Submitted by Rachel Hollon

\$316,000

Original Proposal, October 27, 2025

Unit	Total Cost
------	------------

\$316,000

212867 - Phase #5 - Bid Package #1: Livonia Public Schools - Phase 5 Bid Package 1 - Summer 2026

Prepared by Clark Construction Company - 3535 Moores River Drive, Lansing, MI 48911, United States of America

Bid Package Lead: Michael McKay (mmckay@clarkccc.com)

Project Location: 15125 Farmington Road, Livonia, MI 48154, United States of America

BC-004A: Masonry Generated October 27, 2025	Hicks Masonry Company LLC dba H Submitted by Julie Gantke	BYERS D. C. DETROIT INC. Submitted by Nathan Boeltge	D'Aloisio Masonry & Construction Co Submitted by Lisa Dalozak	Connolly Masonry, Inc. Submitted by John Connolly	J&J Construction Company Submitted by J&J Construction	Brazen & Greer Masonry, Inc. Submitted by Brian Carr	BNE Services, LLC Submitted by Ewan Anton
Base Bid	\$268,930	\$298,400	\$302,500	\$319,440	\$403,740	\$407,300	\$435,000
Original Proposal, October 27, 2025	Original Proposal, October 27, 2025	Original Proposal, October 27, 2025	Original Proposal, October 27, 2025	Original Proposal, October 26, 2025	Original Proposal, October 27, 2025	Original Proposal, October 24, 2025	Original Proposal, October 27, 2025
LINE ITEMS	Unit Total Cost	Unit Total Cost	Unit Total Cost	Unit Total Cost	Unit Total Cost	Unit Total Cost	Unit Total Cost
Masonry (including Bond)	\$268,930	\$298,400	\$302,500	\$319,440	\$403,740	\$407,300	\$435,000

212867 - Phase #5 - Bid Package #1: Livonia Public Schools - Phase 5 Bid Package 1 - Summer 2026

Prepared by Clark Construction Company - 3535 Moores River Drive, Lansing, MI 48911, United States of America

Bid Package Lead: Michael McKay (mmckay@clarkcc.com)

Project Location: 15125 Farmington Road, Livonia, MI 48154, United States of America

BC-005A: Structural Steel

Generated October 27, 2025

Base Bid

LINE ITEMS

Unit	Total Cost
Structural Steel (Including Bond)	\$114,230

Suburban Fabrication

Submitted by brian beasinger

\$114,230

Original Proposal, October 27, 2025

Unit	Total Cost
	\$114,230

Lapeer Steel, Inc.

Submitted by Eric Kosemba

\$156,890

Original Proposal, October 24, 2025

Unit	Total Cost
	\$156,890

Howard Structural Steel, Inc.

Submitted by Patrick Wilding

\$215,013

Original Proposal, October 27, 2025

Unit	Total Cost
	\$215,013

212867 - Phase #5 - Bid Package #1: Livonia Public Schools - Phase 5 Bid Package 1 - Summer 2026

Prepared by Clark Construction Company - 3535 Moore's River Drive, Lansing, MI 48911, United States of America
 Bid Package Lead: Michael McKinley (mmckinley@clarkco.com)
 Project Location: 15125 Farmington Road, Livonia, MI 48154, United States of America

BC-006A1: General Trades - Garfield Generated October 27, 2025	National Specialty Contractors, LLC Submitted by Derrick Tucker	Hicks Construction Company Submitted by April Dobat	Christman Constructors, Inc. Submitted by Dave Riley	Spence Brothers Submitted by Andrew Henry	BJC Services, Inc. Submitted by Nick Murray	Wally Kosorski & Company, Inc. Submitted by Christine Bowen	Graham Construction Corporation So Submitted by Dylan Buttenworth	Pinnacle Contracting LLC Submitted by Chuck Blitner	The Spieker Company Submitted by Front Desk	Clark Contracting Services Submitted by CCS Bidding
Base Bid	\$599,000	\$421,400	\$455,770	\$474,700	\$477,900	\$478,200	\$485,100	\$493,275	\$504,500	\$507,000
	Original Proposal, October 27, 2025	Original Proposal, October 27, 2025	Original Proposal, October 27, 2025	Revision #1, October 27, 2025	Original Proposal, October 27, 2025	Original Proposal, October 27, 2025	Original Proposal, October 27, 2025	Original Proposal, October 27, 2025	Original Proposal, October 27, 2025	Original Proposal, October 27, 2025
LINE ITEMS	Unit Total Cost	Unit Total Cost	Unit Total Cost	Unit Total Cost	Unit Total Cost	Unit Total Cost	Unit Total Cost	Unit Total Cost	Unit Total Cost	Unit Total Cost
General Trades - Garfield (including Bond)	\$599,000	\$421,400	\$455,770	\$474,700	\$477,900	\$478,200	\$485,100	\$493,275	\$504,500	\$507,000

212867 - Phase #5 - Bid Package #1: Livonia Public Schools - Phase 5 Bid Package 1 - Summer 2026

Prepared by Clark Construction Company - 3535 Moores River Drive, Lansing, MI 48911, United States of America

Bid Package Lead: Michael McKay (mmckay@clarkcc.com)

Project Location: 15125 Farmington Road, Livonia, MI 48154, United States of America

BC-006A2: General Trades - Niji Iro & Webster
Generated October 27, 2025

Base Bid

LINE ITEMS

General Trades - Niji Iro & Webster (Including Bond)

Hicks Construction Company
Submitted by April Dobat

\$848,008

Original Proposal, October 27, 2025

Unit	Total Cost
	\$848,008

Spence Brothers
Submitted by Andrew Henry

\$851,500

Original Proposal, October 27, 2025

Unit	Total Cost
	\$851,500

The Spieker Company
Submitted by Front Desk

\$879,500

Original Proposal, October 27, 2025

Unit	Total Cost
	\$879,500

Graham Construction Corporation So
Submitted by Dylan Butterworth

\$898,600

Revision #1, October 27, 2025

Unit	Total Cost
	\$898,600

Clark Contracting Services
Submitted by CCS Bidding

\$947,400

Original Proposal, October 27, 2025

Unit	Total Cost
	\$947,400

BJC Services, Inc.
Submitted by Nick Murray

\$1,106,000

Original Proposal, October 27, 2025

Unit	Total Cost
	\$1,106,000

212867 - Phase #5 - Bid Package #1: Livonia Public Schools - Phase 5 Bid Package 1 - Su

Prepared by Clark Construction Company - 3535 Moores River Drive, Lansing, MI 48911, United States of America

Bid Package Lead: Michael McKay (mmckay@clarkcc.com)

Project Location: 15125 Farmington Road, Livonia, MI 48154, United States of America

BC-007A: Roofing

Generated October 27, 2025

Base Bid

LINE ITEMS

Roofing (Including Bond)

JD Candler Roofing Company, Inc.

Submitted by Aaron Stadler

\$45,700

Original Proposal, October 27, 2025

Unit	Total Cost
	\$45,700

CEI Michigan, LLC

Submitted by Derek Rosiek

\$87,486

Original Proposal, October 27, 2025

Unit	Total Cost
	\$87,486

Lutz Roofing

Brandon Tomayko

\$158,000

Original Proposal, October 27, 2025

Unit	Total Cost
	\$158,000

212867 - Phase #5 - Bid Package #1: Livonia Public Schools - Phase 5 Bid Package 1 - Summer 2026

Prepared by Clark Construction Company - 3535 Moores River Drive, Lansing, MI 48911, United States of America

Bid Package Lead: Michael McKay (mmckay@clarkcc.com)

Project Location: 15125 Farmington Road, Livonia, MI 48154, United States of America

BC-008A: Entrances & Storefronts, Windows, Curtain Wall Generated October 27, 2025 Base Bid	Preferred Glass Inc Submitted by Howard Beindt \$306,503	Vertical Vics Submitted by Christa Bazinski \$42,658	Daniels Glass Co. Inc Submitted by Jeffrey Klapfer \$361,468	Trenko Glass Submitted by Kevin Trenkamp \$391,000	Environmental Glass, Inc. Submitted by Ryan Snabes \$416,900	Clinton Valley Products Submitted by Mark Juliano \$511,250	Hewett Company Submitted by William Hewett \$555,000	Butcher & Butcher Construction Co. Submitted by Matt Hearold \$566,425
Revision #1, October 27, 2025		Original Proposal, October 24, 2025	Original Proposal, October 27, 2025	Original Proposal, October 27, 2025	Original Proposal, October 27, 2025	Original Proposal, October 27, 2025	Original Proposal, October 27, 2025	Original Proposal, October 27, 2025
LINE ITEMS Entrances & Storefronts, Windows, Curtain Wall (Including Bond)	Unit Total Cost <hr/> \$306,503	Unit Total Cost <hr/> \$42,658	Unit Total Cost <hr/> \$361,468	Unit Total Cost <hr/> \$391,000	Unit Total Cost <hr/> \$416,900	Unit Total Cost <hr/> \$511,250	Unit Total Cost <hr/> \$555,000	Unit Total Cost <hr/> \$566,425

212867 - Phase #5 - Bid Package #1: Livonia Public Schools - Phase 5 Bid Package 1 - Summer 2026

Prepared by Clark Construction Company - 3535 Moores River Drive, Lansing, MI 48911, United States of America

Bid Package Lead: Michael McKay (mmckay@clarkcc.com)

Project Location: 15125 Farmington Road, Livonia, MI 48154, United States of America

BC-009A1: Carpentry - Garfield

Generated October 27, 2025

Base Bid

LINE ITEMS

Carpentry - Garfield (Including Bond)

Pontiac Ceiling and Partition Co., LLC

Submitted by David Tomlinson

\$167,728

Original Proposal, October 27, 2025

Unit	Total Cost
	\$167,728

Clark Contracting Services

Submitted by CCS Bidding

\$133,700

Original Proposal, October 27, 2025

Unit	Total Cost
	\$133,700

Turner Brooks

Submitted by Carolyn Conroy

\$182,000

Original Proposal, October 27, 2025

Unit	Total Cost
	\$182,000

BJC Services, Inc.

Submitted by Nick Murray

\$231,250

Original Proposal, October 27, 2025

Unit	Total Cost
	\$231,250

City Renovation & Trim

Submitted by Rick Smith

\$283,560

Original Proposal, October 27, 2025

Unit	Total Cost
	\$283,560

KM Construction, LLC

Submitted by Calvin Sady

\$690,000

Original Proposal, October 27, 2025

Unit	Total Cost
	\$690,000

212867 - Phase #5 - Bid Package #1: Livonia Public Schools - Phase 5 Bid Package 1 - Summer 2026

Prepared by Clark Construction Company - 3535 Moores River Drive, Lansing, MI 48911, United States of America

Bid Package Lead: Michael McKay (mmckay@clarkcc.com)

Project Location: 15125 Farmington Road, Livonia, MI 48154, United States of America

BC-009A2: Carpentry - Niji Iro & Webster Generated October 27, 2025 Base Bid	Pontiac Ceiling and Partition Co., LLC Submitted by David Tomlinson \$338,746 Revision #1, October 27, 2025	Turner Brooks Submitted by Carolyn Conroy \$415,000 Original Proposal, October 27, 2025	Clark Contracting Services Submitted by CCS Bidding \$437,100 Original Proposal, October 27, 2025	City Renovation & Trim Submitted by Rick Smith \$567,630 Original Proposal, October 27, 2025	BJC Services, Inc. Submitted by Nick Murray \$662,525 Original Proposal, October 27, 2025	Wally Kosorski & Company, Inc. Submitted by Christine Bowen \$1,007,760 Original Proposal, October 27, 2025																								
LINE ITEMS Carpentry - Niji Iro & Webster (Including Bond)	<table border="1"> <thead> <tr> <th>Unit</th> <th>Total Cost</th> </tr> </thead> <tbody> <tr> <td></td> <td>\$338,746</td> </tr> </tbody> </table>	Unit	Total Cost		\$338,746	<table border="1"> <thead> <tr> <th>Unit</th> <th>Total Cost</th> </tr> </thead> <tbody> <tr> <td></td> <td>\$415,000</td> </tr> </tbody> </table>	Unit	Total Cost		\$415,000	<table border="1"> <thead> <tr> <th>Unit</th> <th>Total Cost</th> </tr> </thead> <tbody> <tr> <td></td> <td>\$437,100</td> </tr> </tbody> </table>	Unit	Total Cost		\$437,100	<table border="1"> <thead> <tr> <th>Unit</th> <th>Total Cost</th> </tr> </thead> <tbody> <tr> <td></td> <td>\$567,630</td> </tr> </tbody> </table>	Unit	Total Cost		\$567,630	<table border="1"> <thead> <tr> <th>Unit</th> <th>Total Cost</th> </tr> </thead> <tbody> <tr> <td></td> <td>\$662,525</td> </tr> </tbody> </table>	Unit	Total Cost		\$662,525	<table border="1"> <thead> <tr> <th>Unit</th> <th>Total Cost</th> </tr> </thead> <tbody> <tr> <td></td> <td>\$1,007,760</td> </tr> </tbody> </table>	Unit	Total Cost		\$1,007,760
Unit	Total Cost																													
	\$338,746																													
Unit	Total Cost																													
	\$415,000																													
Unit	Total Cost																													
	\$437,100																													
Unit	Total Cost																													
	\$567,630																													
Unit	Total Cost																													
	\$662,525																													
Unit	Total Cost																													
	\$1,007,760																													

212867 - Phase #5 - Bid Package #1: Livonia Public Schools - Phase 5 Bid Package 1 - Summer 2026

Prepared by Clark Construction Company - 3535 Moores River Drive, Lansing, MI 48911, United States of America

Bid Package Lead: Michael McKay (mmckay@clarkcc.com)

Project Location: 15125 Farmington Road, Livonia, MI 48154, United States of America

BC-009B1: Carpet & Resilient Flooring - Garfield <small>Generated October 27, 2025</small>	Flooring Services Inc. <small>Submitted by Amy Johnston</small>	DF Floor Covering <small>Submitted by Dierma Tilton</small>	Omega Floors <small>Submitted by Holly Garrish</small>	Shock Brothers Floorcovering, Inc. <small>Submitted by Charles Shock</small>	Continental Contracting Co., LLC <small>Submitted by Luke posaj</small>	Trist Creek Flooring, Inc. <small>Submitted by Justin Fratric</small>	Premier Tile Design Inc. <small>Submitted by Eugen Ilseel</small>
Base Bid	\$69,384	\$71,147	\$81,500	\$84,450	\$87,290	\$95,800	\$102,300
	Original Proposal, October 27, 2025	Original Proposal, October 27, 2025	Original Proposal, October 26, 2025	Original Proposal, October 27, 2025	Original Proposal, October 27, 2025	Revision #1, October 27, 2025	Original Proposal, October 22, 2025
	Unit Total Cost	Unit Total Cost	Unit Total Cost	Unit Total Cost	Unit Total Cost	Unit Total Cost	Unit Total Cost
LINE ITEMS Carpet & Resilient Flooring - Garfield (Including Bond)	\$69,384	\$71,147	\$81,500	\$84,450	\$87,290	\$95,800	\$102,300

212867 - Phase #5 - Bid Package #1: Livonia Public Schools - Phase 5 Bid Package 1 - Summer 2026

Prepared by Clark Construction Company - 3535 Moores River Drive, Lansing, MI 48911, United States of America

Bid Package Lead: Michael McKay (mmckay@clarkcc.com)

Project Location: 15125 Farmington Road, Livonia, MI 48154, United States of America

BC-009B2: Carpet & Resilient Flooring - Niji Iro & Webster

Generated October 27, 2025

Base Bid

LINE ITEMS

Carpet & Resilient Flooring - Niji Iro & Webster
(Including Bond)

Unit	Total Cost	Unit	Total Cost	Unit	Total Cost	Unit	Total Cost	Unit	Total Cost	Unit	Total Cost	Unit	Total Cost
\$236,850		\$243,465		\$247,900		\$250,700		\$271,567		\$295,950		\$299,000	
	\$236,850		\$243,465		\$247,900		\$250,700		\$271,567		\$295,950		\$299,000

212867 - Phase #5 - Bid Package #1: Livonia Public Schools - Phase 5 Bid Package 1 - Summer 2026

Prepared by Clark Construction Company - 3535 Moores River Drive, Lansing, MI 48911, United States of America

Bid Package Lead: Michael McKay (mmckay@clarkcc.com)

Project Location: 15125 Farmington Road, Livonia, MI 48154, United States of America

BC-009C1: Painting & Wall Covering - Garfield	Conci Painting, LLC Submitted by Alex Dardelakos	GV Painting LLC Submitted by Josh Vutshaj	Continental Contracting Co., LLC Submitted by Luke popal	Twin Brothers Painting Submitted by Eris Vutshaj	Laci Painting LLC Submitted by Gerjol Keqi	G&T Commercial Coatings, Inc. Submitted by Tawid Langit	Detroit Spectrum Painters, Inc. Submitted by Jacob Chapman
Generated October 27, 2025	\$56,900	\$83,700	\$84,549	\$85,500	\$109,500	\$143,410	\$182,000
Original Proposal, October 27, 2025	Original Proposal, October 27, 2025	Original Proposal, October 27, 2025	Original Proposal, October 27, 2025	Original Proposal, October 27, 2025	Original Proposal, October 27, 2025	Original Proposal, October 25, 2025	Original Proposal, October 27, 2025
Base Bid	Unit Total Cost	Unit Total Cost	Unit Total Cost	Unit Total Cost	Unit Total Cost	Unit Total Cost	Unit Total Cost
LINE ITEMS Painting & Wall Covering - Garfield (Including Bond)	\$56,900	\$83,700	\$84,549	\$85,500	\$109,500	\$143,410	\$182,000

212867 - Phase #5 - Bid Package #1: Livonia Public Schools - Phase 5 Bid Package 1 - Summer 2026

Prepared by Clark Construction Company - 3535 Moores River Drive, Lansing, MI 48911, United States of America

Bid Package Lead: Michael McKay (mmckay@clarkcc.com)

Project Location: 15125 Farmington Road, Livonia, MI 48154, United States of America

BC-009C2: Painting and Wall Covering - Niji Iro & Webster
Generated October 27, 2025

Base Bid

LINE ITEMS

Painting and Wall Covering - Niji Iro & Webster
(Including Bond)

Continental Contracting Co., LLC

Submitted by Luke popaj

\$148,300

Original Proposal, October 27, 2025

Unit	Total Cost
	\$148,300

GV Painting LLC

Submitted by Josh Vushaj

\$170,500

Original Proposal, October 27, 2025

Unit	Total Cost
	\$170,500

G&T Commercial Coatings, Inc.

Submitted by Tasso Liangis

\$242,571

Original Proposal, October 25, 2025

Unit	Total Cost
	\$242,571

Twin Brothers Painting

Submitted by Eris Vushaj

\$290,975

Original Proposal, October 27, 2025

Unit	Total Cost
	\$290,975

Laci Painting LLC

Submitted by Gertjol Keqi

\$309,515

Original Proposal, October 27, 2025

Unit	Total Cost
	\$309,515

212867 - Phase #5 - Bid Package #1: Livonia Public Schools - Phase 5 Bid Package 1 - Summer 2026

Prepared by Clark Construction Company - 3535 Moores River Drive, Lansing, MI 48911, United States of America

Bid Package Lead: Michael McKay (mmckay@clarkcc.com)

Project Location: 15125 Farmington Road, Livonia, MI 48154, United States of America

BC-009D: Hard Tile Generated October 27, 2025	DF Floor Covering Submitted by Dennis Talton	E-Ideas Consulting LLC Submitted by ERVIN PRIFTI	Omega Floors Submitted by Holly Garrish	Premier Tile Design Inc. Submitted by Eugen Ilisei																														
Base Bid	\$19,393	\$21,950	\$23,250	\$47,300																														
Original Proposal, October 27, 2025	Original Proposal, October 27, 2025	Original Proposal, October 27, 2025	Original Proposal, October 26, 2025	Original Proposal, October 22, 2025																														
<table border="1"> <thead> <tr> <th>Unit</th> <th>Total Cost</th> </tr> </thead> <tbody> <tr> <td colspan="2">LINE ITEMS</td> </tr> <tr> <td>Hard Tile (Including Bond)</td> <td>\$19,393</td> </tr> </tbody> </table>	Unit	Total Cost	LINE ITEMS		Hard Tile (Including Bond)	\$19,393	<table border="1"> <thead> <tr> <th>Unit</th> <th>Total Cost</th> </tr> </thead> <tbody> <tr> <td colspan="2">LINE ITEMS</td> </tr> <tr> <td></td> <td>\$21,950</td> </tr> </tbody> </table>	Unit	Total Cost	LINE ITEMS			\$21,950	<table border="1"> <thead> <tr> <th>Unit</th> <th>Total Cost</th> </tr> </thead> <tbody> <tr> <td colspan="2">LINE ITEMS</td> </tr> <tr> <td></td> <td>\$23,250</td> </tr> </tbody> </table>	Unit	Total Cost	LINE ITEMS			\$23,250	<table border="1"> <thead> <tr> <th>Unit</th> <th>Total Cost</th> </tr> </thead> <tbody> <tr> <td colspan="2">LINE ITEMS</td> </tr> <tr> <td></td> <td>\$47,300</td> </tr> </tbody> </table>	Unit	Total Cost	LINE ITEMS			\$47,300	<table border="1"> <thead> <tr> <th>Unit</th> <th>Total Cost</th> </tr> </thead> <tbody> <tr> <td colspan="2">LINE ITEMS</td> </tr> <tr> <td></td> <td>\$47,300</td> </tr> </tbody> </table>	Unit	Total Cost	LINE ITEMS			\$47,300
Unit	Total Cost																																	
LINE ITEMS																																		
Hard Tile (Including Bond)	\$19,393																																	
Unit	Total Cost																																	
LINE ITEMS																																		
	\$21,950																																	
Unit	Total Cost																																	
LINE ITEMS																																		
	\$23,250																																	
Unit	Total Cost																																	
LINE ITEMS																																		
	\$47,300																																	
Unit	Total Cost																																	
LINE ITEMS																																		
	\$47,300																																	

212867 - Phase #5 - Bid Package #1: Livonia Public Schools - Phase 5 Bid Package 1 - Summer 2026

Prepared by Clark Construction Company - 3535 Moores River Drive, Lansing, MI 48911, United States of America

Bid Package Lead: Michael McKay (mmckay@clarkcc.com)

Project Location: 15125 Farmington Road, Livonia, MI 48154, United States of America

BC-011A1: Food Service Equipment - Garfield

Generated October 27, 2025

Base Bid

LINE ITEMS

Food Service Equipment - Garfield (Including Bond)

Great Lakes Hotel Supply Company

Submitted by Enis Guzelaydin

\$49,831

Original Proposal, October 27, 2025

Unit	Total Cost
	\$49,831

Stafford-Smith, Inc

Submitted by Kati Shaw

\$54,699

Original Proposal, October 27, 2025

Unit	Total Cost
	\$54,699

212867 - Phase #5 - Bid Package #1: Livonia Public Schools - Phase 5 Bid Package 1 - Summer 2026

Prepared by Clark Construction Company - 3535 Moores River Drive, Lansing, MI 48911, United States of America

Bid Package Lead: Michael McKay (mmckay@clarkcc.com)

Project Location: 15125 Farmington Road, Livonia, MI 48154, United States of America

BC-011A2: Food Service Equipment -
Niji Iro & Webster

Generated October 27, 2025

Base Bid

LINE ITEMS

Food Service Equipment - Niji Iro & Webster
(Including Bond)

Great Lakes Hotel Supply Company

Submitted by Enis Guzelaydin

\$176,179

Original Proposal, October 27, 2025

Unit	Total Cost
	\$176,179

212867 - Phase #5 - Bid Package #1: Livonia Public Schools - Phase 5 Bid Package 1 - Summary

Prepared by Clark Construction Company - 3535 Moores River Drive, Lansing, MI 48911, United States of America

Bid Package Lead: Michael McKay (mmckay@clarkcc.com)

Project Location: 15125 Farmington Road, Livonia, MI 48154, United States of America

BC-026A2: Electrical - Niji Iro & Webster

Generated October 27, 2025

Base Bid

LINE ITEMS

Power Solutions Group Inc. Submitted by EDDIE HAKIM	Great Lakes Power & Lighting, Inc. Submitted by Alan Thueme	Green Line Electric LLC Submitted by Greg Abb												
\$780,969	\$1,387,000	\$1,650,000												
Original Proposal, October 27, 2025	Original Proposal, October 27, 2025	Original Proposal, October 27, 2025												
<table border="0"> <tr> <td style="text-align: left;">Unit</td> <td style="text-align: right;">Total Cost</td> </tr> <tr> <td></td> <td style="text-align: right;">\$780,969</td> </tr> </table>	Unit	Total Cost		\$780,969	<table border="0"> <tr> <td style="text-align: left;">Unit</td> <td style="text-align: right;">Total Cost</td> </tr> <tr> <td></td> <td style="text-align: right;">\$1,387,000</td> </tr> </table>	Unit	Total Cost		\$1,387,000	<table border="0"> <tr> <td style="text-align: left;">Unit</td> <td style="text-align: right;">Total Cost</td> </tr> <tr> <td></td> <td style="text-align: right;">\$1,650,000</td> </tr> </table>	Unit	Total Cost		\$1,650,000
Unit	Total Cost													
	\$780,969													
Unit	Total Cost													
	\$1,387,000													
Unit	Total Cost													
	\$1,650,000													

212867 - Phase #5 - Bid Package #1: Livonia Public Schools - Phase 5 Bid Package 1 - Summer 2026

Prepared by Clark Construction Company - 3535 Moores River Drive, Lansing, MI 48911, United States of America

Bid Package Lead: Michael McKay (mmckay@clarkcc.com)

Project Location: 15125 Farmington Road, Livonia, MI 48154, United States of America

BC-021A: Fire Suppression

Generated October 27, 2025

Base Bid

LINE ITEMS

Fire Suppression (Including Bond)

Jackson Associates

Submitted by Dan Briggs

\$28,160

Original Proposal, October 24, 2025

Unit	Total Cost
	\$28,160

Absolute Fire Protection, Inc.

Submitted by Kristina Krantz

\$37,050

Original Proposal, October 21, 2025

Unit	Total Cost
	\$37,050

Professional Sprinkler, Inc.

Submitted by William Case

\$44,780

Original Proposal, October 27, 2025

Unit	Total Cost
	\$44,780

Grand Rapids Fire Protection, Incorp

Submitted by Cruz Paiz

\$50,000

Original Proposal, October 27, 2025

Unit	Total Cost
	\$50,000

Wolverine Fire Protection Co.

Submitted by Kyle Yerian

\$56,665

Original Proposal, October 27, 2025

Unit	Total Cost
	\$56,665

212867 - Phase #5 - Bid Package #1: Livonia Public Schools - Phase 5 Bid Package 1 - Summer 2026

Prepared by Clark Construction Company - 3535 Moores River Drive, Lansing, MI 48911, United States of America

Bid Package Lead: Michael McKay (mmckay@clarkcc.com)

Project Location: 15125 Farmington Road, Livonia, MI 48154, United States of America

BC-022A1: Plumbing - Garfield <small>Submitted by October 27, 2025</small>	CSM Mechanical LLC <small>Submitted by Jon Trusey</small>	Mills Mechanical <small>Submitted by Benjy Jackson</small>	De-Cal, Inc. <small>Submitted by Jordan Collins</small>	JM & Sons Plumbing Company <small>Submitted by Stefano Lubenowich</small>	Johnson & Wood, LLC <small>Submitted by Jon Clark</small>	A.J. Miller Mechanical, Inc. <small>Submitted by Dage Drebnik</small>	Ainsworth Inc. <small>Submitted by Corey Merano</small>	Alpine Mechanical Contractors <small>Submitted by David Scullerak</small>																																																						
Base Bid	\$128,000	\$130,200	\$133,450	\$137,120	\$158,500	\$159,218	\$171,438	\$257,590																																																						
<small>Original Proposal, October 27, 2025</small>	<small>Original Proposal, October 27, 2025</small>	<small>Original Proposal, October 27, 2025</small>	<small>Original Proposal, October 27, 2025</small>	<small>Original Proposal, October 27, 2025</small>	<small>Original Proposal, October 27, 2025</small>	<small>Original Proposal, October 27, 2025</small>	<small>Original Proposal, October 27, 2025</small>	<small>Original Proposal, October 27, 2025</small>																																																						
<table border="1"> <thead> <tr> <th>Unit</th> <th>Total Cost</th> </tr> </thead> <tbody> <tr> <td colspan="2">LINE ITEMS</td> </tr> <tr> <td>Plumbing - Garfield (Including Bond)</td> <td>\$128,000</td> </tr> </tbody> </table>	Unit	Total Cost	LINE ITEMS		Plumbing - Garfield (Including Bond)	\$128,000	<table border="1"> <thead> <tr> <th>Unit</th> <th>Total Cost</th> </tr> </thead> <tbody> <tr> <td colspan="2">LINE ITEMS</td> </tr> <tr> <td></td> <td>\$130,200</td> </tr> </tbody> </table>	Unit	Total Cost	LINE ITEMS			\$130,200	<table border="1"> <thead> <tr> <th>Unit</th> <th>Total Cost</th> </tr> </thead> <tbody> <tr> <td colspan="2">LINE ITEMS</td> </tr> <tr> <td></td> <td>\$133,450</td> </tr> </tbody> </table>	Unit	Total Cost	LINE ITEMS			\$133,450	<table border="1"> <thead> <tr> <th>Unit</th> <th>Total Cost</th> </tr> </thead> <tbody> <tr> <td colspan="2">LINE ITEMS</td> </tr> <tr> <td></td> <td>\$137,120</td> </tr> </tbody> </table>	Unit	Total Cost	LINE ITEMS			\$137,120	<table border="1"> <thead> <tr> <th>Unit</th> <th>Total Cost</th> </tr> </thead> <tbody> <tr> <td colspan="2">LINE ITEMS</td> </tr> <tr> <td></td> <td>\$158,500</td> </tr> </tbody> </table>	Unit	Total Cost	LINE ITEMS			\$158,500	<table border="1"> <thead> <tr> <th>Unit</th> <th>Total Cost</th> </tr> </thead> <tbody> <tr> <td colspan="2">LINE ITEMS</td> </tr> <tr> <td></td> <td>\$159,218</td> </tr> </tbody> </table>	Unit	Total Cost	LINE ITEMS			\$159,218	<table border="1"> <thead> <tr> <th>Unit</th> <th>Total Cost</th> </tr> </thead> <tbody> <tr> <td colspan="2">LINE ITEMS</td> </tr> <tr> <td></td> <td>\$171,438</td> </tr> </tbody> </table>	Unit	Total Cost	LINE ITEMS			\$171,438	<table border="1"> <thead> <tr> <th>Unit</th> <th>Total Cost</th> </tr> </thead> <tbody> <tr> <td colspan="2">LINE ITEMS</td> </tr> <tr> <td></td> <td>\$257,590</td> </tr> </tbody> </table>	Unit	Total Cost	LINE ITEMS			\$257,590	<table border="1"> <thead> <tr> <th>Unit</th> <th>Total Cost</th> </tr> </thead> <tbody> <tr> <td colspan="2">LINE ITEMS</td> </tr> <tr> <td></td> <td>\$257,590</td> </tr> </tbody> </table>	Unit	Total Cost	LINE ITEMS			\$257,590
Unit	Total Cost																																																													
LINE ITEMS																																																														
Plumbing - Garfield (Including Bond)	\$128,000																																																													
Unit	Total Cost																																																													
LINE ITEMS																																																														
	\$130,200																																																													
Unit	Total Cost																																																													
LINE ITEMS																																																														
	\$133,450																																																													
Unit	Total Cost																																																													
LINE ITEMS																																																														
	\$137,120																																																													
Unit	Total Cost																																																													
LINE ITEMS																																																														
	\$158,500																																																													
Unit	Total Cost																																																													
LINE ITEMS																																																														
	\$159,218																																																													
Unit	Total Cost																																																													
LINE ITEMS																																																														
	\$171,438																																																													
Unit	Total Cost																																																													
LINE ITEMS																																																														
	\$257,590																																																													
Unit	Total Cost																																																													
LINE ITEMS																																																														
	\$257,590																																																													

212867 - Phase #5 - Bid Package #1: Livonia Public Schools - Phase 5 Bid Package 1 - Summer 2026

Prepared by Clark Construction Company - 3535 Moores River Drive, Lansing, MI 48911, United States of America

Bid Package Lead: Michael McKay (mmckay@clarkcc.com)

Project Location: 15125 Farmington Road, Livonia, MI 48154, United States of America

BC-022A2: Plumbing - Niji Iro & Webster
Generated October 27, 2025

Base Bid

A.J. Miller Mechanical, Inc.
Submitted by Gage Dietrich

\$227,802

Original Proposal, October 27, 2025

Unit	Total Cost
------	------------

LINE ITEMS

Plumbing - Niji Iro & Webster (Including Bond)

\$227,802

Mills Mechanical
Submitted by Benny Jackson

\$229,100

Original Proposal, October 27, 2025

Unit	Total Cost
------	------------

\$229,100

De-Cal, Inc.
Submitted by Jordan Collina

\$274,000

Original Proposal, October 27, 2025

Unit	Total Cost
------	------------

\$274,000

JM & Sons Plumbing Company
Submitted by Jamie Johnson

\$286,800

Original Proposal, October 27, 2025

Unit	Total Cost
------	------------

\$286,800

Johnson & Wood, LLC
Submitted by Jon Clark

\$360,300

Original Proposal, October 27, 2025

Unit	Total Cost
------	------------

\$360,300

Alpine Mechanical Contractors
Submitted by Daniel Szaflarski

\$503,000

Original Proposal, October 27, 2025

Unit	Total Cost
------	------------

\$503,000

212867 - Phase #5 - Bid Package #1: Livonia Public Schools - Phase 5 Bid Package 1 - Summer 2026

Prepared by Clark Construction Company - 3535 Moores River Drive, Lansing, MI 48911, United States of America

Bid Package Lead: Michael McKay (mmckay@clarkcc.com)

Project Location: 15125 Farmington Road, Livonia, MI 48154, United States of America

BC-023A1: HVAC - Garfield Generated October 27, 2025	De-Cal, Inc. Submitted by Jordan Colina	Peter Basso Associates, Inc. Submitted by Whitney Andoni	Johnson & Wood, LLC Submitted by Jon Clark	Ainsworth Inc. Submitted by Korey Mersino										
Base Bid	\$1,711,800	\$62,800	\$2,074,000	\$2,375,480										
Original Proposal, October 27, 2025	Original Proposal, October 27, 2025	Original Proposal, October 27, 2025	Original Proposal, October 27, 2025	Original Proposal, October 27, 2025										
<table border="0"> <thead> <tr> <th style="text-align: left;">Unit</th> <th style="text-align: right;">Total Cost</th> </tr> </thead> </table>	Unit	Total Cost	<table border="0"> <thead> <tr> <th style="text-align: left;">Unit</th> <th style="text-align: right;">Total Cost</th> </tr> </thead> </table>	Unit	Total Cost	<table border="0"> <thead> <tr> <th style="text-align: left;">Unit</th> <th style="text-align: right;">Total Cost</th> </tr> </thead> </table>	Unit	Total Cost	<table border="0"> <thead> <tr> <th style="text-align: left;">Unit</th> <th style="text-align: right;">Total Cost</th> </tr> </thead> </table>	Unit	Total Cost	<table border="0"> <thead> <tr> <th style="text-align: left;">Unit</th> <th style="text-align: right;">Total Cost</th> </tr> </thead> </table>	Unit	Total Cost
Unit	Total Cost													
Unit	Total Cost													
Unit	Total Cost													
Unit	Total Cost													
Unit	Total Cost													
<table border="0"> <thead> <tr> <th colspan="2">LINE ITEMS</th> </tr> </thead> <tbody> <tr> <td>HVAC - Garfield (Including Bond)</td> <td style="text-align: right;">\$1,711,800</td> </tr> </tbody> </table>	LINE ITEMS		HVAC - Garfield (Including Bond)	\$1,711,800	<table border="0"> <tbody> <tr> <td></td> <td style="text-align: right;">\$62,800</td> </tr> </tbody> </table>		\$62,800	<table border="0"> <tbody> <tr> <td></td> <td style="text-align: right;">\$2,074,000</td> </tr> </tbody> </table>		\$2,074,000	<table border="0"> <tbody> <tr> <td></td> <td style="text-align: right;">\$2,375,480</td> </tr> </tbody> </table>		\$2,375,480	
LINE ITEMS														
HVAC - Garfield (Including Bond)	\$1,711,800													
	\$62,800													
	\$2,074,000													
	\$2,375,480													

212867 - Phase #5 - Bid Package #1: Livonia Public Schools - Phase 5 Bid Package 1 - Summer 2026

Prepared by Clark Construction Company - 3535 Moores River Drive, Lansing, MI 48911, United States of America

Bid Package Lead: Michael McKay (mmckay@clarkcc.com)

Project Location: 15125 Farmington Road, Livonia, MI 48154, United States of America

BC-023A2: HVAC - Niji Iro & Webster

Generated October 27, 2025

Base Bid

LINE ITEMS

HVAC - Niji Iro & Webster (Including Bond)

De-Cal, Inc.

Submitted by Jordan Colina

\$1,448,800

Original Proposal, October 27, 2025

Unit	Total Cost
	\$1,448,800

Johnson & Wood, LLC

Submitted by Jon Clark

\$1,794,000

Revision #1, October 27, 2025

Unit	Total Cost
	\$1,794,000

212867 - Phase #5 - Bid Package #1: Livonia Public Schools - Phase

Prepared by Clark Construction Company - 3535 Moores River Drive, Lansing, MI 48911, United States of America

Bid Package Lead: Michael McKay (mmckay@clarkcc.com)

Project Location: 15125 Farmington Road, Livonia, MI 48154, United States of America

BC-026A1: Electrical - Garfield

Generated October 27, 2025

Base Bid

LINE ITEMS

Green Line Electric LLC

Submitted by Greg Abb

\$850,000

Original Proposal, October 27, 2025

Unit	Total Cost
	\$850,000

Great Lakes Power & Lighting, Inc.

Submitted by Alan Thueme

\$1,387,000

Original Proposal, October 27, 2025

Unit	Total Cost
	\$1,387,000



Date: November 7, 2025

To: Andrea Oquist, Superintendent

From: William Green, Assistant Superintendent of Operations and District Services

Re: Purchase of Bulk Salt

I would like to request adding an agenda item to the November 10, 2025, Committee of the Whole Meeting to discuss the purchase of salt for our district.

Background

Each school year, we purchase bulk salt to support winter maintenance operations across the district. We currently have approximately 800 tons left from the 2024-2025 school year supply. The salt is used to treat parking lots, sidewalks, building entrances, and other high-traffic areas on school property. This proactive approach helps prevent ice buildup, reduces slip-and-fall risks, and ensures safe access for students, staff, and visitors during inclement weather. The Facilities and Operations team monitors weather conditions and applies salt as needed to maintain safety and minimize disruptions to school activities.

Recommendation

Facilities and Operations issued a public bid to Detroit Salt Company, Compass Minerals, and Morton Salt Company. Detroit Salt Company was the only respondent, indicating they would not submit a bid. Following the bid process, we requested quotes from the same companies.

We selected Detroit Salt Company to supply our usual annual quantity of 1000 tons of road salt for the 2025–2026 winter season. The cost is \$63.97 per ton, reflecting an increase of \$3.62 per ton from the 2024–2025 school year." The total cost for the purchase of salt is \$63,970. Funding for this purchase will come from the General Fund.

Please include this item on the agenda. Thank you.

Attachment

c: Board of Education

WG/AS



Livonia Public School

Facilities and Operations

Date: October 16, 2025

To: William Green, Assistant Superintendent of District Services

From: Harry C. Lau, Administrator of Facilities and Operations

Subject: Recommendation to Purchase Bulk Road Salt

I am recommending and seeking approval to purchase bulk road salt from Detroit Salt Company at a cost of \$63.97 per ton. The price difference from the 2024-25 school year is increased by \$3.62 per ton for a total increase of \$3,620. Livonia Public Schools is requesting to purchase 1,000 tons, totaling \$63,970.00. This purchase will be funded through the General Fund.

The Office of Facilities and Operations issued a public bid to three companies: Detroit Salt Company, Compass Minerals, and Morton Salt Company. The only response received was from Detroit Salt Company, indicating they would not submit a bid.

Following the bid process, we requested quotes from the same three companies. Detroit Salt Company submitted a quote at the above stated contract price of \$63.97 per ton.

Thank you for your consideration of this recommendation.

cc: A. Sutton



DETROIT SALT • COMPANY

10/09/2025

Livonia Public Schools
Attn: William Green, Superintendent of District Services
15125 Farmington Road
Livonia, MI 48154-5474

RE: Bulk Road Salt Bid
Bidding 10/13/25 at 12:00 p.m.

Dear Mr. Green,

Regarding your invitation to bid on the purchase of Bulk Road Salt, The Detroit Salt Company respectfully submits a No Bid for product at this time.

We would request that you keep us on your bidders list and that you email us the bid tabulations once opened.

Sincerely,

Steven M. Briggs

Steven M. Briggs (Oct 9, 2025 10:41:10 CDT)

Steven M. Briggs
Vice President, US Sales and Marketing
Detroit Salt Company, L.C.

12841 Sander Street, Detroit, MI 48217 | sales@detroitsalt.com

**Bulk Salt Bid
 Central Office Complex
 October 13, 2025 BID OPENING
 12:00 P.M.**

VENDORS BIDDING DESCRIPTION:	Detroit Salt Company	Morton Salt Company	Compass Minerals		
TOTAL:					
DEDUCT:					
BID BOND:					
EQUAL OPPORTUNITY:					
SWORN AND NOTARIZED FAMILIAL DISCLOSURE STATEMENT:					
IRAN SANCTIONS STATEMENT:					
ADDENDUM I:					
ADDENDUM II:					
FIRM REPRESENTATIVE PARTICIPATED IN MANDATORY PRE BID SITE INSPECTION					40
DEDUCT:					
PRICE FIRM FOR 90 DAYS:					
TERMS OF PAYMENT:					
ADDITIONAL SHEETS:					
COMMENTS:	Sent letter indicating not submitting a bid	Did not submit a bid	Did not submit a bid		
GRAND TOTAL:					
RECORDED BY: Harry Lau <i>Harry Lau</i>	DATE: 10.13.25		WITNESSED BY: <i>Patricia Bushnell</i>	DATE: 10.13.25	



SALES QUOTE

Sell To LIVONIA PUBLIC SCHOOLS
 Patrice Bushart / Keith
 15125 FARMINGTON RD
 Livonia, MI 48154
 UNITED STATES

Sales Quote No. SQ25-04420
Sales Quote Date 9/11/2025
Contract End Date 04/30/2026
Customer ID MILIV02
Payment Terms NET 30 Days



Ship to	Comments
LIVONIA PUBLIC SCHOOLS 15125 FARMINGTON RD Livonia, USA 48154	Orders are to be placed in increments of 50 tons.

Product	Unit	Location	Qty	Price per ton
SALT	Tons	Detroit, MI	1000	\$63.97

Please review 'Sell To' and 'Ship To' address information above and advise if any changes are required.

Do you wish to change the tonnage? YES ___ NO ___ New requested tonnage is _____ short tons.
 Reason for tonnage change: _____

To confirm and accept this quote, please sign this form and return via e-mail, mail or fax to SELLER within thirty (30) days of the date of this quote.
 CUSTOMER ACCEPTANCE: I accept this price quote for CUSTOMER for Season 2025/2026.
 CUSTOMER's Signature: _____ Date: _____

This quote is valid for acceptance by CUSTOMER within thirty (30) days after the date of issuance. If this form is not signed and returned by CUSTOMER to SELLER within thirty (30) days, then the quote is null and void. This quote is not binding on Seller until CUSTOMER's signed acceptance form is accepted and confirmed in writing by Seller.

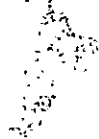



SALES QUOTE

Sell To LIVONIA PUBLIC SCHOOLS
 Patrice Bushart / Keith
 15125 FARMINGTON RD
 Livonia, MI 48154
 UNITED STATES

Sales Quote No. SQ25-04420
Sales Quote Date 9/11/2025
Contract End Date 04/30/2026
Customer ID MILIV02
Payment Terms NET 30 Days

- Delivered prices are based upon full truckload quantities from SELLER's location to specified delivery locations noted in ship-to section. Minimum order is 50 tons. Any applicable taxes are extra.
- Tonnage Commitment: SELLER agrees to supply up to 100% of the Quoted Tonnage, and CUSTOMER guarantees to purchase a minimum of 70% of the total Quoted Tonnage by contract end. Initial order must be placed by March 15, 2026. SELLER will invoice CUSTOMER for any shortfall below the minimum committed tonnage at the quoted price within thirty (30) days of the purchase deadline.

STANDARD TERMS FOR BULK DEICING SALT CUSTOMERS

"SELLER" means Detroit Salt, L.C. (for sales in Michigan) or Morton Salt, Inc

"CUSTOMER" means the customer signing the price quote; and "TONS" means short tons

1. Orders based on the price quote are subject to the terms and conditions set forth herein, and no agreement or other understanding in any way modifying or supplementing these conditions shall be binding upon SELLER unless made in writing and signed by an authorized executive of SELLER.
2. All orders are subject to product availability. SELLER reserves the right to decline any order, suspend a shipment, or terminate an existing order for any reason that affects SELLER's ability to deliver product, including, without limitation, conditions at production facilities or terminals of SELLER or SELLER's affiliates.
3. Effort will be made to ship Product as soon as possible after an order is accepted by SELLER, however SELLER shall not be responsible for any delay or failure to deliver caused wholly or in part by any cause not resulting from SELLER'S negligence, including without limitation, fire, flood, accident, strike, labor trouble, civil commotion, acts of terrorism, war, demands, requests or requirements of governmental authority, failure in production equipment, product availability, inability to obtain fuel, power, raw materials or shipping capacity or acts of God, including snow, ice or other weather-related problems. Transportation surcharges may be applied in the event of significant cost increases in transportation beyond the reasonable control of SELLER.
4. Please order at least 24 hours prior to the expected delivery date. Delivered pricing quotes are based on shipments made in dump trucks carrying a minimum quantity of 22-25 tons per shipment, except for the following: in Michigan, there is 50-ton minimum quantity (or single trailer 25-ton minimum); in Utah: a 40-ton minimum (or single trailer, 25 ton minimum or in-axle truck 18-ton minimum); in Ohio: piler delivery-200 ton minimum; a 10-ton minimum per truck pickup where offered and available. Normal delivery is 1 to 5 business days.
5. Prices quoted are good for the product sourced from the stated shipping location. Any orders for product quantities exceeding Quoted Tonnage is subject to product availability and may be declined by SELLER with no liability to Customer, or may be sourced from an alternate shipping location within SELLER's network of affiliates, and are subject to price adjustment for incremental transportation costs incurred by SELLER to fulfill such orders. SELLER reserves the right: (i) to direct Customer pickups to an alternate shipping locations within a specific market (within fifty(50) miles of the original shipping location), depending on SELLER's inventory availability, and (ii) charge a fee for any in-transit load that is diverted from its original destination in order to fulfill CUSTOMER's order. For delivered pricing quotes, if fuel costs rise to a level requiring carriers to implement a fuel surcharge, SELLER reserves the right to invoice Customer for the fuel surcharge amount as an additional charge that will be shown as a separate line item on the invoice. If implemented, the fuel surcharge amount may vary weekly, and are based on the fuel cost averages published at www.eia.doe.gov.
6. Orders placed for pickup may not be available for 24 hours from the time the order is placed.
7. SELLER warrants the product sold hereunder is suitable for ice control only. SELLER's liability is limited to providing additional material, to the extent any material is shown to be otherwise than warranted, and SELLER shall be in no event liable otherwise or for indirect or consequential damages. THIS WARRANTY IS EXCLUSIVE AND IN LIEU OF ALL OTHER WARRANTIES, INCLUDING BUT NOT LIMITED TO, ANY IMPLIED WARRANTY OF MERCHANTABILITY OR FITNESS FOR A PARTICULAR PURPOSE.
8. Any claims of quantity errors, quality issues, or damages must be made in writing to SELLER within five (5) days of delivery and must include satisfactory evidence. Customer, by acceptance of the Product, assumes all risk and responsibility incident to the handling and use of said product and for the results obtained through the use of said material, and shall indemnify and hold SELLER harmless of and from any and all claims with respect thereto.
9. The price quote does not include any sales, use or other taxes, which will be added to the price, if applicable, as a separate line item at time of invoicing. All purchases are subject to the appropriate sales tax rate, and the Customer will be charged such tax unless Customer is exempt and has provided SELLER with the appropriate sales tax exemption certificate for Customer.
10. Payment is due net thirty (30) days, subject to SELLER's Credit Department approval. SELLER reserves the right to charge a one and a half percent (1 ½%) per month service charge on amounts outstanding more than thirty (30) days from the date of the invoice, effective as of the thirty-first day from the date of invoice. SELLER also reserves the right upon notice to CUSTOMER to condition any future shipments (including those previously ordered or in transit) upon SELLER'S receipt of cash, certified or cashier's check in the amount of the invoiced price for such shipments and inclusive of all freight.
11. In the event of a product shortage, SELLER has the right to allocate available product among its customers, including itself.



Date: November 7, 2025

To: Andrea Oquist, Superintendent

From: William Green, Assistant Superintendent of Operations and District Services

Re: Purchase of Hydration Stations

I would like to discuss the results of the bid for additional Hydration Station installations at the upcoming Committee of the Whole meeting on November 10, 2025.

Background

As discussed last November and again at our Study Session this past September, LPS has been installing filters on drinking fountains inside PreK–2 classrooms as well as Hydration Stations. This continued work is part of the Filter First initiative from the Clean Drinking Water Access Act.

Hydration Stations are being installed in all school buildings at a ratio of one station per 100 students. In addition to this, we are capping all drinking fountains in classrooms beyond grade 2. Students in grades 3 and above will use Hydration Stations for their consumable water needs. Filters are also being installed in all kitchen prep sinks and other designated areas that may require water consumption. The filters LPS has installed—and continues to install—remove lead, copper, and *PFAS. As part of the Clean Drinking Water Access Act, we are required to create and maintain a drinking water management plan, which maintains records of all related work.

We are on track to have all required filters and Hydration Stations installed by June 2026 to meet the State of Michigan requirements.

Recommendation

After reviewing the proposal and evaluating past performance, the administration recommends awarding the project to Spartan Construction Inc., Livonia Michigan, in the total amount of \$483,000. The funding for this purchase will be provided through the Filter First Grant. We did not have good bid coverage as we only received one bid. After consulting with the Michigan Department of Environment, Great Lakes, and Energy (EGLE) we are cleared to go with one bidder and the company securing the bid has a great reputation and past history working with our school district.

Please include this item on the agenda. Thank you.

Attachment

c: Board of Education

WG/AS



Livonia Public Schools

Facilities and Operations

Date: October 30, 2025

To: William Green, Assistant Superintendent District Services

From: Harry C. Lau, Administrator of Facilities and Operations

Re: Letter of Recommendation – Hydration Station Installation Re-Bid

I am recommending and seeking approval to award the Hydration Station Installation Re-Bid to Spartan Construction. The project cost will be \$483,000, which will be funded through the general fund and reimbursed by the Filter First Grant.

Spartan Construction successfully completed the Armco building renovation in 2022. They were on time, on budget, and did a good job completing the Armco building.

Thank you for consideration.

cc: A. Sutton

APPENDIX B
BID PRICING FORM
LIVONIA PUBLIC SCHOOLS

REQUEST FOR BIDS FOR HYDRATION STATION INSTALLATION REBID

<u>Contractor Information</u>	
<u>Contractor Name:</u> spartan construction group Inc.	
<u>Business Address:</u> 30956 Industrial Rd. Livonia, MI 48150	
<u>Contact Person:</u> matt spisak	<u>Telephone:</u> 734-331-5061
<u>E-Mail:</u> matt@spartan-constructiongroup.com	<u>Fax:</u>

A. CONTRACTOR PRICING

1. **Lump Sum Pricing:** The Bid pricing is to be broken down into the below components. All Bid pricing is to include all costs and expenses for the Work in accordance with the RFB, the Specifications, the Minimum Compliance Requirements and the Contract. All pricing shall be on a lump sum basis which includes all costs and expenses of Contractor to complete the respective Work, such as all supplies, materials, labor, equipment, Prevailing Wage Rates, insurance, permits, bonds (if applicable), taxes, overhead/profit, etc.

<u>LUMP SUM PRICING PARAMETERS</u>		
<u>Component of Work</u>	<u>Total Amount (in US Dollars)</u>	<u>Days to Complete</u>
Base Bid	\$ 478,000.00	
Cost of Performance and Payment Bonds	\$ 5,000.00	N/A
TOTAL:	\$ 483,000.00	N/A

2. **Unit Pricing (if applicable):** In addition to the Lump Sum above, please provide unit pricing for any applicable components of the Work, i.e., equipment and its installation cost, that will be available to the School District to purchase at the identified price for a minimum of one (1) year following Substantial Completion of the Work.

<u>UNIT PRICING PARAMETERS</u>		
<u>Unit Pricing by Product</u>	<u>Total Amount (in US Dollars)</u>	
	\$ _____	
	\$ _____	
	\$ _____	
<u>Installation Costs per Product</u>	<u>Total Amount (in US Dollars)</u>	<u>Days to Complete</u>
	\$ _____	
	\$ _____	
TOTAL:	\$ _____	N/A

B. WARRANTIES

Please detail the type and length of all warranties offered by the Contractor under this Bid for the following: 1) **labor/installation**; and 2) **materials and equipment**. Please detail what is covered by each warranty, what conditions are part of the warranty and what are the exclusions to the warranty, if any.

C. OTHER RFB REQUIREMENTS

1. Please include the following with this Bid Form:
 - a) List of References (see 2.2.3 of RFB)
 - b) Provide Proof of required insurance coverages and bonds (See 2.2.4 of RFB)
 - c) List of Subcontractors (See 2.2.12 of RFB)
 - d) Provide a Copy of Contractor’s State Project Registration.

D. PREVAILING WAGE RATES

The State Prevailing Wage Rates for this project for all classes of construction mechanics required for the Work are contained behind **APPENDIX A-1**.

E. EXCEPTIONS

Please provide a detailed list of any exceptions or special considerations you have to the terms and conditions of the RFB and the Contract. This must include a detailed reference to the corresponding section of the RFB the Contract, and explanations for the same. (Use additional pages if necessary). NONE

_____.

F. ACKNOWLEDGEMENT OF ADDENDA TO RFB

The Contractor acknowledges receipt of the following addenda:

Addendum Number 1 dated 09-24-25
Addendum Number _____ dated _____
Addendum Number _____ dated _____

The undersigned declares that they have carefully examined the instructions, the Specifications, Minimum Compliance Requirements and the Contract, and agrees to furnish these items and the Work within such Specifications for the price set forth in this Bid. The undersigned and/or its representative attended the Pre-Bid Conference and fully understands the detailed Specifications presented and discussed. The undersigned hereby confirms that they have of all licenses necessary to perform the Work. The undersigned has carefully checked all of its Bid figures and understands that it shall be responsible for any error or omission in this Bid and is in receipt of all Addenda as issued. The undersigned understands that the School District reserves the right to accept or reject in whole or in part any and all Bids, to waive informalities and irregularities therein, and to award the Contract to other than the Contractor submitting the best financial Bid (low bidder) and to award the Contract to one (1) or more Contractors in the School District's sole and absolute discretion.

If award is made to our firm based upon our Bid, we agree to enter into the attached form of Contract with the School District to furnish the Work in strict accordance with this Request For Bid, the Contract and our Bid.

My signature certifies that the Bid as submitted complies with all terms and conditions as set forth in this Request For Bid and the Contract, unless specifically enumerated as an exception as part of our Bid.

The undersigned certifies that they are authorized to sign as a Representative for the undersigned Contractor.

THE BELOW CONTRACTOR HEREBY SUBMITS THIS BID PRICING FORM IN ACCORDANCE WITH THE TERMS AND CONDITIONS OF THE RFB.

Contractor Name: Spartan construction Group Inc.

Authorized Individual Name: Matt Spisak

Position/Title: President

Signature: 

Date: 10/21/25

APPENDIX D

AFFIDAVIT OF COMPLIANCE – IRAN ECONOMIC SANCTIONS ACT
Michigan Public Act No. 517 of 2012

The undersigned, the owner or authorized officer of the below-named contractor (“Contractor”), pursuant to the compliance certification requirement provided in the Livonia Public Schools’ (the “School District”) Request For Bids Hydration Station Installation Rebid (the “RFB”), hereby certifies, represents and warrants that the Contractor (including its officers, directors and employees) is not an “Iran linked business” within the meaning of the Iran Economic Sanctions Act, Michigan Public Act No. 517 of 2012 (the “Act”), and that in the event Contractor is awarded a contract as a result of the aforementioned RFB, the Contractor will not become an “Iran linked business” at any time during the course of performing the Work or any services under the contract.

The Contractor further acknowledges that any person who is found to have submitted a false certification is responsible for a civil penalty of not more than \$250,000.00 or 2 times the amount of the contract or proposed contract for which the false certification was made, whichever is greater, the cost of the School District’s investigation, and reasonable attorney fees, in addition to the fine. Moreover, any person who submitted a false certification shall be ineligible to bid on a request for bids/proposal for three (3) years from the date it is determined that the person has submitted the false certification.

CONTRACTOR:

spartan construction group inc.
Name of Contractor

By: [Signature]

Its: officer

Date: 10-20-25

STATE OF Michigan)
)ss.
COUNTY OF Wayne)

This instrument was acknowledged before me on the 20 day of October, 2025, by Matthew Sprink.

[Signature]

, Notary Public

Wayne County, Michigan

My Commission Expires: Sep 15 2030

Acting in the County of Wayne

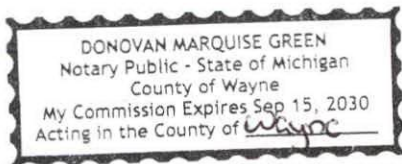

THE AMERICAN INSTITUTE OF ARCHITECTS



AIA Document A310 Bid Bond

KNOW ALL MEN BY THESE PRESENTS, that **WE SPARTAN CONSTRUCTION GROUP, INC.** 30956
Industrial Rd. Livonia, MI 48160

(Here insert full name and address or legal title of Contractor)

as Principal, hereinafter called the Principal, and The Ohio Casualty Insurance Company Boston, MA 02116
a corporation duly organized under the laws of the State of NH as Surety, hereinafter called the Surety, are held and
firmly bound unto Livonia Public Schools 15125 Farmington Road Livonia, MI 48164

(Here insert full name and address or legal title of Owner)

as Obligee, hereinafter called the Obligee, in the sum of 5.00% Att Bid
For the payment of which sum well and truly to be made, the said Principal and the said Surety, bind ourselves, our
heirs, executors, administrators, successors and assigns, jointly and severally, firmly by these presents.

WHEREAS, the Principal has submitted a bid for
Livonia Public Schools Hydration Station Replacements

(Here insert full name, address and description of project)

NOW, THEREFORE, if the Obligee shall accept the bid of the Principal and the Principal shall enter into a Contract
with the Obligee in accordance with the terms of such bid and give such bond or bonds as may be specified in the
bidding or Contract Documents with good and sufficient surety for the faithful performance of such Contract and for
the prompt payment of labor and material furnished in the prosecution thereof, or in the event of the failure of the
Principal to enter such Contract and give such bond or bonds, if the Principal shall pay to the Obligee the difference
not to exceed the penalty hereof between the amount specified in said bid and such larger amount for which the
Obligee may in good faith contract with another party to perform the Work covered by said bid then this obligation
shall be null and void, otherwise to remain in full force and effect.

Signed and sealed this 30th day of September, 2025

(Witness)

SPARTAN CONSTRUCTION GROUP, INC.
(Principal)  (Seal)

(Witness)

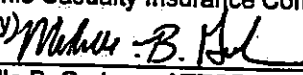
The Ohio Casualty Insurance Company
(Surety)  (Seal)
Michelle B. Graham, ATTORNEY-IN-FACT

AIA DOCUMENT A310 BID BOND AIA © FEBRUARY 1970 ED THE AMERICAN
INSTITUTE OF ARCHITECTS, 1735 N.Y. AVE., N.W. WASHINGTON, D.C. 20006



POWER OF ATTORNEY

Certificate No: 8213453-013058

Liberty Mutual Insurance Company
The Ohio Casualty Insurance Company
West American Insurance Company

KNOWN ALL PERSONS BY THESE PRESENTS: That The Ohio Casualty Insurance Company is a corporation duly organized under the laws of the State of New Hampshire, that Liberty Mutual Insurance Company is a corporation duly organized under the laws of the State of Massachusetts, and West American Insurance Company is a corporation duly organized under the laws of the State of Indiana (herein collectively called the "Companies"), pursuant to and by authority herein set forth, does hereby name, constitute and appoint, Lois C. Brink; Suzan Giacoma; Michelle B. Graham; Alexandra Johnson; Suzanne M. Mocerri

all of the city of Royal Oak state of MI each individually if there be more than one named, its true and lawful attorney-in-fact to make, execute, seal, acknowledge and deliver, for and on its behalf as surety and as its act and deed, any and all undertakings, bonds, recognizances and other surety obligations, in pursuance of these presents and shall be as binding upon the Companies as if they have been duly signed by the president and attested by the secretary of the Companies in their own proper persons.

IN WITNESS WHEREOF, this Power of Attorney has been subscribed by an authorized officer or official of the Companies and the corporate seals of the Companies have been affixed thereto this 25th day of March, 2025.



Liberty Mutual Insurance Company
The Ohio Casualty Insurance Company
West American Insurance Company

By: Nathan J. Zengerle, Assistant Secretary

State of PENNSYLVANIA ss
County of MONTGOMERY

On this 25th day of March, 2025 before me personally appeared Nathan J. Zengerle, who acknowledged himself to be the Assistant Secretary of Liberty Mutual Insurance Company, The Ohio Casualty Company, and West American Insurance Company, and that he, as such, being authorized so to do, execute the foregoing instrument for the purposes therein contained by signing on behalf of the corporations by himself as a duly authorized officer.

IN WITNESS WHEREOF, I have hereunto subscribed my name and affixed my notarial seal at Plymouth Meeting, Pennsylvania, on the day and year first above written.



Commonwealth of Pennsylvania - Notary Seal
Teresa Pastella, Notary Public
Montgomery County
My commission expires March 28, 2029
Commission number 1128044
Member, Pennsylvania Association of Notaries

By: Teresa Pastella, Notary Public

This Power of Attorney is made and executed pursuant to and by authority of the following By-laws and Authorizations of The Ohio Casualty Insurance Company, Liberty Mutual Insurance Company, and West American Insurance Company which resolutions are now in full force and effect reading as follows:

ARTICLE IV - OFFICERS: Section 12. Power of Attorney.

Any officer or other official of the Corporation authorized for that purpose in writing by the Chairman or the President, and subject to such limitation as the Chairman or the President may prescribe, shall appoint such attorneys-in-fact, as may be necessary to act in behalf of the Corporation to make, execute, seal, acknowledge and deliver as surety any and all undertakings, bonds, recognizances and other surety obligations. Such attorneys-in-fact, subject to the limitations set forth in their respective powers of attorney, shall have full power to bind the Corporation by their signature and execution of any such instruments and to attach thereto the seal of the Corporation. When so executed, such instruments shall be as binding as if signed by the President and attested to by the Secretary. Any power or authority granted to any representative or attorney-in-fact under the provisions of this article may be revoked at any time by the Board, the Chairman, the President or by the officer or officers granting such power or authority.

ARTICLE XIII - Execution of Contracts: Section 5. Surety Bonds and Undertakings.

Any officer of the Company authorized for that purpose in writing by the chairman or the president, and subject to such limitations as the chairman or the president may prescribe, shall appoint such attorneys-in-fact, as may be necessary to act in behalf of the Company to make, execute, seal, acknowledge and deliver as surety any and all undertakings, bonds, recognizances and other surety obligations. Such attorneys-in-fact subject to the limitations set forth in their respective powers of attorney, shall have full power to bind the Company by their signature and execution of any such instruments and to attach thereto the seal of the Company. When so executed such instruments shall be as binding as if signed by the president and attested by the secretary.

Certificate of Designation - The President of the Company, acting pursuant to the Bylaws of the Company, authorizes Nathan J. Zengerle, Assistant Secretary to appoint such attorneys-in-fact as may be necessary to act on behalf of the Company to make, execute, seal, acknowledge and deliver as surety any and all undertakings, bonds, recognizances and other surety obligations.

Authorization - By unanimous consent of the Company's Board of Directors, the Company consents that facsimile or mechanically reproduced signature of any assistant secretary of the Company, wherever appearing upon a certified copy of any power of attorney issued by the Company in connection with surety bonds, shall be valid and binding upon the Company with the same force and effect as though manually affixed.

I, Renee C. Llewellyn, the undersigned, Assistant Secretary, The Ohio Casualty Insurance Company, Liberty Mutual Insurance Company, and West American Insurance Company do hereby certify that the original power of attorney of which the foregoing is a full, true and correct copy of the Power of Attorney executed by said Companies, is in full force and effect and has not been revoked.

IN TESTIMONY WHEREOF, I have hereunto set my hand and affixed the seals of said Companies this 30th day of September, 2025.



By: Renee C. Llewellyn, Assistant Secretary

Not valid for mortgage, note, loan, letter of credit, currency rate, interest rate or residual value guarantees.

For bond and/or Power of Attorney (POA) verification inquiries, please call 610-832-8240 or email HOSUR@libertymutual.com



Date: November 10, 2025

To: Andrea Oquist, Superintendent

From: William Green, Assistant Superintendent of Operations and District Services

Re: Purchase of Lockdown Shades

I would like the opportunity to present to the Board of Education information regarding the installation of lockdown safety shades and the proposed quote for additional work on this project across the buildings in our school district.

Background

Over the past year, we have been working on installing Lockdown Safety Shades in schools throughout our district. Many doors/sidelights in each school building would benefit from shades. The shades can be quickly pulled down during a lockdown to prevent visibility into classrooms. This is an added security measure designed to help protect our students and staff in the event of a potential threat or the immediate need for privacy.

Recommendation

We received samples from three vendors based on our initial series of orders. Among them, Taylor Nightlock, Clio, Michigan, provided the highest quality in the exact shades we required, at a total cost of \$45,095.68.

Please add this request to the agenda of the Monday, November 10, 2025, Committee of the Whole Meeting.

Attachment

WG/AS

c: Board of Education



Taylor Brothers Door Lock, LLC.

840 Tacoma Court
Clio, MI 48420-1581

Quote

Date	Estimate #
12/18/2023	6941

Name / Address
Livonia Public Schools Phillip Francis 15125 Farmington Rd Livonia, MI 48154

Received samples from all 3 vendors and Nightlock was the best/preferred shade of the 3 companies ✓ this 1-29-24

Description	Qty	Rate	Total
LSS1236 Lockdown Safety Shade 12 in W x 36 in L	850	19 99	16,991 50
Shipping - UPS		292 55	292 55

Note: It is your responsibility to acquire any approvals needed from local code officials prior to installation. Make sure you inform local police and fire departments when locks are installed in their jurisdictions.
 Note: Refund Policy: If returning unused product, we offer a full refund minus freight costs and a 20% restocking fee. No returns or refunds on custom shades.
 Note: Install policy: Nightlock can provide professional installation anywhere in the continental US. Nightlock is not responsible for failures or damage resulting from installation by customer or third party installer.

Subtotal	\$17,284 05
Sales Tax (0.0%)	\$0 00
Total	\$17,284.05

ALP, Inc.
 1109 Grand Avenue, Unit 4
 North Bergen, NJ 07047
 201-867-8795
 info@alpsewing.com



Quote

ADDRESS

Accounts Payable- Business
 Office
 Livonia Public Schools
 15125 Farmington Rd
 Livonia, MI 48154

SHIP TO

Phillip M Francis
 Livonia Public Schools
 15125 Farmington Rd
 Livonia, MI 48154

QUOTE # 2738

DATE 12/18/2023

EXPIRATION DATE 01/31/2024

ACTIVITY	DESCRIPTION	QTY	RATE	AMOUNT
TF Custom Blackout Size	TF Custom Blackout Shade 11" W x 36" L -- designed to fit glass window pane dimensions as specified	850	16 49	14,016 50
S & H	Shipping & Handling Charges - TBD		0 00	0 00

To accept this quote, please sign and return via email or fax. No orders will be processed without a signed quote or purchase order.

TOTAL

\$14,016.50

By signing below, I am accepting responsibility as an authorized representative of the school/company making this purchase and agree to fully comply with the payment terms as established by ALP.

In the event any third parties are employed to collect any outstanding monies owed by said school/company, the undersigned agrees to pay reasonable collection costs as allowed by ALP's maximum state allowance, including attorney fees, whether or not litigation has commenced, and all costs of litigation incurred.

Fax 678-606-9323

RETURN POLICY Customers have 30 days from receipt of product to return for replacement or refund minus cost of shipping. Only standard sizes (not custom) with intact adhesive backing can be accepted for return. Damaged products must also be exchanged within 30 days.

Absolutely no returns are allowed for custom shades.

Accepted By

Accepted Date

Quote

12/18/23

**CAROLINA COVERTECH, INC DBA
SCHOOL SAFETY SOLUTION**
<https://www.schoolsafetysolution.com/>
114 Shortcut Rd
North Augusta, South Carolina 29860
United States
1 (888) 733-0406

QUOTE #
052577
BILLED TO PHILLIP FRANCIS
Livonia Public Schools
15125 Farmington Rd
Livonia, MI 48154

PRODUCT	QUANTITY	PRICE	TOTAL
HHC11X36WT <i>Custom shade size: 11 Inches W X 36 Inches L FINISHED SIZE designed to fit glass window pane measuring 8 Inches W X 32 Inches L. Includes weighted hem bar</i>	850	\$23.99	\$20,391.50
S & H FREIGHT <i>Shipping & Handling via FREIGHT</i>	1	\$399.32	\$399.32
Volume Discount <i>Discount amount reflected below</i>	1	\$0.00	\$0.00

DISCOUNT	\$2,039.15
TOTAL	\$18,751.67

PLEASE MAKE NOTE OF OUR ADDRESS:

School Safety Solution
114 Shortcut Rd
North Augusta, SC 29860
info@schoolsafetysolution.com
Follow us on LinkedIn and Facebook!

RETURN POLICY

Lockdown Shades: ONLY STANDARD SIZES with intact adhesive backing can be accepted for return. CUSTOM SIZES ARE NOT RETURNABLE. Customers have 30 days from receipt of the product to return STANDARD SIZES for replacement or refund. Shipping costs are non-refundable.

Other Products: Returns are only accepted on unused or damaged products. Customers have 30 days from receipt of the product to apply for a refund, minus the cost of shipping and handling.

Shipping charges for returned products are customers responsibility. For TeacherLock products, there is a 20% Restocking Fee assessed for returned products. For Safebolt, there will be a 25% Restocking fee assessed for all returned items.

Damaged products must be reported within 15 days.

**I have thoroughly reviewed each lockdown shade size I have requested and have read the Return Policy. I understand that custom lockdown shades are NOT RETURNABLE. By my signature below, I am confirming that I wish to place this order and that I understand the Return Policy presented by School Safety Solution for all products covered by this quote.

SIGN HERE TO ACCEPT QUOTE: _____



Taylor Brothers Door Lock, LLC.

840 Tacoma Court
Clio, MI 48420-1581

Quote

Date	Estimate #
10/17/2025	11684

Name / Address
Livonia Public Schools ap@livoniapublicschools.org

Rep
CA

Description	Qty	Rate	Total
FOR: Buchanan LSS2636 Lockdown Safety Shade 26 in. W x 36 in. L	35	32.99	1,154.65
Shipping - Provided by Nightlock		0.00	0.00

Note: It is your responsibility to acquire any approvals needed from local code officials prior to installation. Make sure you inform local police and fire departments when locks are installed in their jurisdictions.
 Note: Refund Policy: If returning unused product, we offer a full refund minus freight costs and a 20% restocking fee. No returns or refunds on custom shades.
 Note: Install policy: Nightlock can provide professional installation anywhere in the continental US.
 Nightlock is not responsible for failures or damage resulting from installation by customer or third party installer.

Subtotal	\$1,154.65
Sales Tax (0.0%)	\$0.00
Total	\$1,154.65

Phone # 855-644-4856 www.nightlock.com



Taylor Brothers Door Lock, LLC.

840 Tacoma Court
Clio, MI 48420-1581

Quote

Date	Estimate #
10/17/2025	11683

Name / Address
Livonia Public Schools ap@livoniapublicschools.org

Rep
CA

Description	Qty	Rate	Total
FOR: Churchill LSS1242 Lockdown Safety Shade 12 in. W x 42 in. L	66	20.99	1,385.34
Shipping - Provided by Nightlock		0.00	0.00

Note: It is your responsibility to acquire any approvals needed from local code officials prior to installation. Make sure you inform local police and fire departments when locks are installed in their jurisdictions.
 Note: Refund Policy: If returning unused product, we offer a full refund minus freight costs and a 20% restocking fee. No returns or refunds on custom shades.
 Note: Install policy: Nightlock can provide professional installation anywhere in the continental US.
 Nightlock is not responsible for failures or damage resulting from installation by customer or third party installer.

Subtotal	\$1,385.34
Sales Tax (0.0%)	\$0.00
Total	\$1,385.34

Phone # 855-644-4856 www.nightlock.com



Taylor Brothers Door Lock, LLC.

840 Tacoma Court
Clio, MI 48420-1581

Quote

Date	Estimate #
10/17/2025	11682

Name / Address
Livonia Public Schools ap@livoniapublicschools.org

Rep
CA

Description	Qty	Rate	Total
FOR: Coolidge LSSCU3366 Lockdown Safety Shade 33 in. W x 66 in. L	20	93.75	1,875.00
LSSCU3324 Lockdown Safety Shade 33 in. W x 24 in. L	12	43.75	525.00
LSS2642 Lockdown Safety Shade 26 in. W x 42 in. L	8	35.99	287.92
LSS2636 Lockdown Safety Shade 26 in. W x 36 in. L	8	32.99	263.92
LSSCU2689 Lockdown Safety Shade 26 in. W x 89 in. L	2	99.74	199.48
Shipping - Provided by Nightlock		0.00	0.00

Note: It is your responsibility to acquire any approvals needed from local code officials prior to installation. Make sure you inform local police and fire departments when locks are installed in their jurisdictions.
 Note: Refund Policy: If returning unused product, we offer a full refund minus freight costs and a 20% restocking fee. No returns or refunds on custom shades.
 Note: Install policy: Nightlock can provide professional installation anywhere in the continental US.
 Nightlock is not responsible for failures or damage resulting from installation by customer or third party installer.

Subtotal	\$3,151.32
Sales Tax (0.0%)	\$0.00
Total	\$3,151.32



Taylor Brothers Door Lock, LLC.

840 Tacoma Court
Clio, MI 48420-1581

Quote

Date	Estimate #
10/16/2025	11664

Name / Address
Livonia Public Schools ap@livoniapublicschools.org

Rep
CA

Description	Qty	Rate	Total
FOR: COOPER LSSCU2648 Lockdown Safety Shade 26 in. W x 48 in. L	5	68.75	343.75
LSS2642 Lockdown Safety Shade 26 in. W x 42 in. L	3	35.99	107.97
LSS1242 Lockdown Safety Shade 12 in. W x 42 in. L	5	20.99	104.95
Provided by Nightlock		0.00	0.00

Note: It is your responsibility to acquire any approvals needed from local code officials prior to installation. Make sure you inform local police and fire departments when locks are installed in their jurisdictions.
 Note: Refund Policy: If returning unused product, we offer a full refund minus freight costs and a 20% restocking fee. No returns or refunds on custom shades.
 Note: Install policy: Nightlock can provide professional installation anywhere in the continental US.
 Nightlock is not responsible for failures or damage resulting from installation by customer or third party installer.

Subtotal	\$556.67
Sales Tax (0.0%)	\$0.00
Total	\$556.67



Taylor Brothers Door Lock, LLC.

840 Tacoma Court
Clio, MI 48420-1581

Quote

Date	Estimate #
10/16/2025	11651

Name / Address
Livonia Public Schools ap@livoniapublicschools.org

Rep
CA

Description	Qty	Rate	Total
FOR: Emerson LSS2642 Lockdown Safety Shade 26 in. W x 42 in. L	11	35.99	395.89
LSSCU3248 Lockdown Safety Shade 32 in. W x 48 in. L	4	84.50	338.00
LSSCU3236 Lockdown Safety Shade 32 in. W x 36 in. L	4	63.50	254.00
LSSCU3648 Lockdown Safety Shade 36 in. W x 48 in. L	1	95.25	95.25
LSSCU3642 Lockdown Safety Shade 36 in. W x 42 in. L	1	83.25	83.25
LSSCU4848 Lockdown Safety Shade 48 in. W x 48 in. L	2	99.25	198.50
LSSCU3652 Lockdown Safety Shade 36 in. W x 52 in. L	1	103.00	103.00
LSSCU3632 Lockdown Safety Shade 36 in. W x 32 in. L	1	63.50	63.50
LSSCU3276 Lockdown Safety Shade 32 in. W x 76 in. L	2	104.75	209.50
LSSCU10148 Lockdown Safety Shade 101 in. W x 48 in. L	1	208.50	208.50
LSSCU2448 Lockdown Safety Shade 24 in. W x 48 in. L	9	63.50	571.50
LSS2636 Lockdown Safety Shade 26 in. W x 36 in. L	9	32.99	296.91
Shipping - Provided by Nightlock		0.00	0.00

Note: It is your responsibility to acquire any approvals needed from local code officials prior to installation. Make sure you inform local police and fire departments when locks are installed in their jurisdictions.
 Note: Refund Policy: If returning unused product, we offer a full refund minus freight costs and a 20% restocking fee. No returns or refunds on custom shades.
 Note: Install policy: Nightlock can provide professional installation anywhere in the continental US.
 Nightlock is not responsible for failures or damage resulting from installation by customer or third party installer.

Subtotal	\$2,817.80
Sales Tax (0.0%)	\$0.00
Total	\$2,817.80



Taylor Brothers Door Lock, LLC.

840 Tacoma Court
Clio, MI 48420-1581

Quote

Date	Estimate #
10/16/2025	11660

Name / Address
Livonia Public Schools ap@livoniapublicschools.org

Rep
CA

Description	Qty	Rate	Total
FOR: Franklin LSS1042 Lockdown Safety Shade 10 in. W x 42 in. L	9	18.99	170.91
Shipping - Provided by Nightlock		0.00	0.00

Note: It is your responsibility to acquire any approvals needed from local code officials prior to installation. Make sure you inform local police and fire departments when locks are installed in their jurisdictions.
 Note: Refund Policy: If returning unused product, we offer a full refund minus freight costs and a 20% restocking fee. No returns or refunds on custom shades.
 Note: Install policy: Nightlock can provide professional installation anywhere in the continental US.
 Nightlock is not responsible for failures or damage resulting from installation by customer or third party installer.

Subtotal	\$170.91
Sales Tax (0.0%)	\$0.00
Total	\$170.91



Taylor Brothers Door Lock, LLC.

840 Tacoma Court
Clio, MI 48420-1581

Quote

Date	Estimate #
10/16/2025	11657

Name / Address
Livonia Public Schools ap@livoniapublicschools.org

Rep
CA

Description	Qty	Rate	Total
FOR: Garfield			
LSSCU9080 Lockdown Safety Shade 90 in. W x 80 in. L	2	309.75	619.50
LSSCU2380 Lockdown Safety Shade 23 in. W x 80 in. L	2	101.25	202.50
LSSCU3280 Lockdown Safety Shade 32 in. W x 80 in. L	1	110.25	110.25
LSSCU7680 Lockdown Safety Shade 76 in. W x 80 in. L	1	261.50	261.50
LSSCU7678 Lockdown Safety Shade 76 in. W x 78 in. L	6	255.00	1,530.00
LSSCU3880 Lockdown Safety Shade 38 in. W x 80 in. L	1	130.75	130.75
LSSCU10680 Lockdown Safety Shade 106 in. W x 80 in. L	1	364.75	364.75
LSSCU13578 Lockdown Safety Shade 13.5 in. W x 78 in. L	5	60.25	301.25
LSSCU37578 Lockdown Safety Shade 37.5 in. W x 78 in. L	8	127.50	1,020.00
LSSCU35578 Lockdown Safety Shade 35.5 in. W x 78 in. L	2	120.75	241.50
LSSCU30580 Lockdown Safety Shade 30.5 in. W x 80 in. L	4	106.75	427.00
LSSCU3678 Lockdown Safety Shade 36 in. W x 78 in. L	2	120.75	241.50
LSSCU3878 Lockdown Safety Shade 38 in. W x 78 in. L	2	127.50	255.00
Shipping - Provided by Nightlock		0.00	0.00

Note: It is your responsibility to acquire any approvals needed from local code officials prior to installation. Make sure you inform local police and fire departments when locks are installed in their jurisdictions.
 Note: Refund Policy: If returning unused product, we offer a full refund minus freight costs and a 20% restocking fee. No returns or refunds on custom shades.
 Note: Install policy: Nightlock can provide professional installation anywhere in the continental US.
 Nightlock is not responsible for failures or damage resulting from installation by customer or third party installer.

Subtotal	\$5,705.50
Sales Tax (0.0%)	\$0.00
Total	\$5,705.50

Phone # 855-644-4856 www.nightlock.com



Taylor Brothers Door Lock, LLC.

840 Tacoma Court
Clio, MI 48420-1581

Quote

Date	Estimate #
10/16/2025	11650

Name / Address
Livonia Public Schools ap@livoniapublicschools.org

Rep
CA

Description	Qty	Rate	Total
FOR: Grant LSS1242 Lockdown Safety Shade 12 in. W x 42 in. L	12	20.99	251.88
LSSCU4060 Lockdown Safety Shade 40 in. W x 60 in. L	2	103.23	206.46
LSSCU4031 Lockdown Safety Shade 40 in. W x 31 in. L	2	68.25	136.50
LSS2636 Lockdown Safety Shade 26 in. W x 36 in. L	4	32.99	131.96
LSSCU1750 Lockdown Safety Shade 17 in. W x 50 in. L	1	46.75	46.75
LSSCU1734 Lockdown Safety Shade 17 in. W x 34 in. L	1	32.00	32.00
LSS2636 Lockdown Safety Shade 26 in. W x 36 in. L	1	32.99	32.99
LSSCU2026 Lockdown Safety Shade 20 in. W x 26 in. L	1	28.75	28.75
LSSCU2651 Lockdown Safety Shade 26 in. W x 51 in. L	3	73.00	219.00
LSS2636 Lockdown Safety Shade 26 in. W x 36 in. L	3	32.99	98.97
LSSCU3456 Lockdown Safety Shade 34 in. W x 56 in. L	4	104.75	419.00
LSSCU3030 Lockdown Safety Shade 30 in. W x 30 in. L	2	49.50	99.00
LSSCU2858 Lockdown Safety Shade 28 in. W x 58 in. L	8	89.50	716.00
Grant New Windows LSSCU1246 Lockdown Safety Shade 12 in. W x 46 in. L	4	30.50	122.00
LSSCU2733 Lockdown Safety Shade 27 in. W x 33 in. L	2	49.25	98.50

Note: It is your responsibility to acquire any approvals needed from local code officials prior to installation. Make sure you inform local police and fire departments when locks are installed in their jurisdictions.
 Note: Refund Policy: If returning unused product, we offer a full refund minus freight costs and a 20% restocking fee. No returns or refunds on custom shades.
 Note: Install policy: Nightlock can provide professional installation anywhere in the continental US.
 Nightlock is not responsible for failures or damage resulting from installation by customer or third party installer.

Subtotal

Sales Tax (0.0%)

Total



Taylor Brothers Door Lock, LLC.

840 Tacoma Court
Clio, MI 48420-1581

Quote

Date	Estimate #
10/16/2025	11650

Name / Address
Livonia Public Schools ap@livoniapublicschools.org

Rep
CA

Description	Qty	Rate	Total
LSSCU3224 Lockdown Safety Shade 32 in. W x 24 in. L	2	42.25	84.50
LSSCU3356 Lockdown Safety Shade 33 in. W x 56 in. L	4	101.75	407.00
LSS2636 Lockdown Safety Shade 26 in. W x 36 in. L	1	32.99	32.99
Shipping - Delivered by Nightlock **Shipping for all locations***		250.00	250.00

Note: It is your responsibility to acquire any approvals needed from local code officials prior to installation. Make sure you inform local police and fire departments when locks are installed in their jurisdictions.
 Note: Refund Policy: If returning unused product, we offer a full refund minus freight costs and a 20% restocking fee. No returns or refunds on custom shades.
 Note: Install policy: Nightlock can provide professional installation anywhere in the continental US.
 Nightlock is not responsible for failures or damage resulting from installation by customer or third party installer.

Subtotal	\$3,414.25
Sales Tax (0.0%)	\$0.00
Total	\$3,414.25



Taylor Brothers Door Lock, LLC.

840 Tacoma Court
Clio, MI 48420-1581

Quote

Date	Estimate #
10/16/2025	11667

Name / Address
Livonia Public Schools ap@livoniapublicschools.org

Rep
CA

Description	Qty	Rate	Total
FOR: Hayes LSSCU44825 Lockdown Safety Shade 44 in. W x 82.5 in. L	21	157.25	3,302.25
LSSCU28855 Lockdown Safety Shade 28 in. W x 85.5 in. L	2	103.75	207.50
LSS2642 Lockdown Safety Shade 26 in. W x 42 in. L	1	35.99	35.99
LSS2636 Lockdown Safety Shade 26 in. W x 36 in. L	1	32.99	32.99
LSS2642 Lockdown Safety Shade 26 in. W x 42 in. L	1	35.99	35.99
LSSCU425845 Lockdown Safety Shade 42.5 in. W x 84.5 in. L	2	157.25	314.50
LSSCU38579 Lockdown Safety Shade 38.5 in. W x 79 in. L	1	132.50	132.50
LSSCU385805 Lockdown Safety Shade 38.5 in. W x 80.5 in. L	1	136.00	136.00
LSSCU205305 Lockdown Safety Shade 20.5 in. W x 30.5 in. L	2	36.00	72.00
LSSCU205265 Lockdown Safety Shade 20.5 in. W x 26.5 in. L	2	31.25	62.50
Shipping - Provided by Nightlock		0.00	0.00

Note: It is your responsibility to acquire any approvals needed from local code officials prior to installation. Make sure you inform local police and fire departments when locks are installed in their jurisdictions.
 Note: Refund Policy: If returning unused product, we offer a full refund minus freight costs and a 20% restocking fee. No returns or refunds on custom shades.
 Note: Install policy: Nightlock can provide professional installation anywhere in the continental US.
 Nightlock is not responsible for failures or damage resulting from installation by customer or third party installer.

Subtotal	\$4,332.22
Sales Tax (0.0%)	\$0.00
Total	\$4,332.22

Phone # 855-644-4856 www.nightlock.com



Taylor Brothers Door Lock, LLC.

840 Tacoma Court
Clio, MI 48420-1581

Quote

Date	Estimate #
10/16/2025	11663

Name / Address
Livonia Public Schools ap@livoniapublicschools.org

Rep
CA

Description	Qty	Rate	Total
FOR: Holmes LSSCU3840 Lockdown Safety Shade 38 in. W x 40 in. L	6	83.75	502.50
LSS2642 Lockdown Safety Shade 26 in. W x 42 in. L	1	35.99	35.99
LSS2636 Lockdown Safety Shade 26 in. W x 36 in. L	4	32.99	131.96
LSSCU3640 Lockdown Safety Shade 36 in. W x 40 in. L	3	79.25	237.75
LSSCU4456 Lockdown Safety Shade 44 in. W x 56 in. L	1	106.00	106.00
LSSCU2856 Lockdown Safety Shade 28 in. W x 56 in. L	1	86.25	86.25
Shipping - Provided by Nightlock		0.00	0.00

Note: It is your responsibility to acquire any approvals needed from local code officials prior to installation. Make sure you inform local police and fire departments when locks are installed in their jurisdictions.
 Note: Refund Policy: If returning unused product, we offer a full refund minus freight costs and a 20% restocking fee. No returns or refunds on custom shades.
 Note: Install policy: Nightlock can provide professional installation anywhere in the continental US.
 Nightlock is not responsible for failures or damage resulting from installation by customer or third party installer.

Subtotal	\$1,100.45
Sales Tax (0.0%)	\$0.00
Total	\$1,100.45

Phone # 855-644-4856 www.nightlock.com



Taylor Brothers Door Lock, LLC.

840 Tacoma Court
Clio, MI 48420-1581

Quote

Date	Estimate #
10/16/2025	11648

Name / Address
Livonia Public Schools ap@livoniapublicschools.org

Rep
CA

Description	Qty	Rate	Total
FOR: HOOVER LSS1242 Lockdown Safety Shade 12 in. W x 42 in. L	22	20.99	461.78
LSSCU2150 Lockdown Safety Shade 21 in. W x 50 in. L	1	57.75	57.75
LSS2642 Lockdown Safety Shade 26 in. W x 42 in. L	1	35.99	35.99
LSS2842 Lockdown Safety Shade 28 in. W x 42 in. L	1	42.99	42.99
LSS2636 Lockdown Safety Shade 26 in. W x 36 in. L	1	32.99	32.99
LSSCU4050 Lockdown Safety Shade 40 in. W x 50 in. L	1	110.00	110.00
LSSCU1448 Lockdown Safety Shade 14 in. W x 48 in. L	6	37.00	222.00
Shipping - Provided by Nightlock		0.00	0.00

Note: It is your responsibility to acquire any approvals needed from local code officials prior to installation. Make sure you inform local police and fire departments when locks are installed in their jurisdictions.
 Note: Refund Policy: If returning unused product, we offer a full refund minus freight costs and a 20% restocking fee. No returns or refunds on custom shades.
 Note: Install policy: Nightlock can provide professional installation anywhere in the continental US.
 Nightlock is not responsible for failures or damage resulting from installation by customer or third party installer.

Subtotal	\$963.50
Sales Tax (0.0%)	\$0.00
Total	\$963.50

Phone # 855-644-4856 www.nightlock.com



Taylor Brothers Door Lock, LLC.

840 Tacoma Court
Clio, MI 48420-1581

Quote

Date	Estimate #
10/16/2025	11653

Name / Address
Livonia Public Schools ap@livoniapublicschools.org

Rep
CA

Description	Qty	Rate	Total
FOR: Johnson			
LSS0836 Lockdown Safety Shade 08 in. W x 36 in. L	2	15.99	31.98
LSS2636 Lockdown Safety Shade 26 in. W x 36 in. L	6	32.99	197.94
LSSCU2553 Lockdown Safety Shade 25 in. W x 53 in. L	1	73.00	73.00
LSSCU4251 Lockdown Safety Shade 42 in. W x 51 in. L	2	92.25	184.50
LSSCU6951 Lockdown Safety Shade 69 in. W x 51 in. L	1	151.50	151.50
LSS2636 Lockdown Safety Shade 26 in. W x 36 in. L	2	32.99	65.98
LSS0836 Lockdown Safety Shade 08 in. W x 36 in. L	1	15.99	15.99
LSSCU1751 Lockdown Safety Shade 17 in. W x 51 in. L	1	47.75	47.75
LSSCU3452 Lockdown Safety Shade 34 in. W x 52 in. L	8	97.25	778.00
LSSCU2151 Lockdown Safety Shade 21 in. W x 51 in. L	1	59.00	59.00
LSS0836 Lockdown Safety Shade 08 in. W x 36 in. L	1	15.99	15.99
LSSCU3553 Lockdown Safety Shade 35 in. W x 53 in. L	2	102.25	204.50
LSSCU2031 Lockdown Safety Shade 20 in. W x 31 in. L	2	34.25	68.50
Shipping - Provided by Nightlock		0.00	0.00

Note: It is your responsibility to acquire any approvals needed from local code officials prior to installation. Make sure you inform local police and fire departments when locks are installed in their jurisdictions.
 Note: Refund Policy: If returning unused product, we offer a full refund minus freight costs and a 20% restocking fee. No returns or refunds on custom shades.
 Note: Install policy: Nightlock can provide professional installation anywhere in the continental US.
 Nightlock is not responsible for failures or damage resulting from installation by customer or third party installer.

Subtotal	\$1,894.63
Sales Tax (0.0%)	\$0.00
Total	\$1,894.63

Phone # 855-644-4856 www.nightlock.com



Taylor Brothers Door Lock, LLC.

840 Tacoma Court
Clio, MI 48420-1581

Quote

Date	Estimate #
10/16/2025	11647

Name / Address
Livonia Public Schools ap@livoniapublicschools.org

Rep
CA

Description	Qty	Rate	Total
FOR: Kennedy LSS2642 Lockdown Safety Shade 26 in. W x 42 in. L	1	35.99	35.99
LSSCU3648 Lockdown Safety Shade 36 W X in. W x 48 in. L	3	90.75	272.25
LSSCU3848 Lockdown Safety Shade 38 in. W x 48 in. L	1	100.50	100.50
Shipping - Provided by Nightlock		0.00	0.00

Note: It is your responsibility to acquire any approvals needed from local code officials prior to installation. Make sure you inform local police and fire departments when locks are installed in their jurisdictions.
 Note: Refund Policy: If returning unused product, we offer a full refund minus freight costs and a 20% restocking fee. No returns or refunds on custom shades.
 Note: Install policy: Nightlock can provide professional installation anywhere in the continental US.
 Nightlock is not responsible for failures or damage resulting from installation by customer or third party installer.

Subtotal	\$408.74
Sales Tax (0.0%)	\$0.00
Total	\$408.74



Taylor Brothers Door Lock, LLC.

840 Tacoma Court
Clio, MI 48420-1581

Quote

Date	Estimate #
10/16/2025	11654

Name / Address
Livonia Public Schools ap@livoniapublicschools.org

Rep
CA

Description	Qty	Rate	Total
FOR: LCTC			
LSSCU1045 Lockdown Safety Shade 10 in. W x 45 in. L	1	24.75	24.75
LSSCU2476 Lockdown Safety Shade 24 in. W x 76 in. L	9	100.50	904.50
LSSCU3848 Lockdown Safety Shade 38 in. W x 48 in. L	3	95.25	285.75
LSSCU3624 Lockdown Safety Shade 36 in. W x 24 in. L	1	47.75	47.75
LSSCU2535 Lockdown Safety Shade 25 in. W x 35 in. L	1	48.25	48.25
LSSCU1216 Lockdown Safety Shade 12 in. W x 16 in. L	2	18.00	36.00
LSSCU2545 Lockdown Safety Shade 25 in. W x 45 in. L	2	62.00	124.00
LSSCU2526 Lockdown Safety Shade 25 in. W x 26 in. L	2	35.75	71.50
LSSCU3024 Lockdown Safety Shade 30 in. W x 24 in. L	2	39.75	79.50
LSSCU3048 Lockdown Safety Shade 30 in. W x 48 in. L	2	79.25	158.50
LSSCU3076 Lockdown Safety Shade 30 in. W x 76 in. L	2	98.25	196.50
Shipping - Provided by Nightlock		0.00	0.00

Note: It is your responsibility to acquire any approvals needed from local code officials prior to installation. Make sure you inform local police and fire departments when locks are installed in their jurisdictions.
 Note: Refund Policy: If returning unused product, we offer a full refund minus freight costs and a 20% restocking fee. No returns or refunds on custom shades.
 Note: Install policy: Nightlock can provide professional installation anywhere in the continental US.
 Nightlock is not responsible for failures or damage resulting from installation by customer or third party installer.

Subtotal	\$1,977.00
Sales Tax (0.0%)	\$0.00
Total	\$1,977.00

Phone # 855-644-4856 www.nightlock.com



Taylor Brothers Door Lock, LLC.

840 Tacoma Court
Clio, MI 48420-1581

Quote

Date	Estimate #
10/16/2025	11665

Name / Address
Livonia Public Schools ap@livoniapublicschools.org

Rep
CA

Description	Qty	Rate	Total
FOR: LECC LSS2642 Lockdown Safety Shade 26 in. W x 42 in. L	17	35.99	611.83
LSS2636 Lockdown Safety Shade 26 in. W x 36 in. L	17	32.99	560.83
LSSCU17547 Lockdown Safety Shade 17.5 in. W x 47 in. L	61	46.75	2,851.75
Shipping - Provided by Nightlock		0.00	0.00

Note: It is your responsibility to acquire any approvals needed from local code officials prior to installation. Make sure you inform local police and fire departments when locks are installed in their jurisdictions.
 Note: Refund Policy: If returning unused product, we offer a full refund minus freight costs and a 20% restocking fee. No returns or refunds on custom shades.
 Note: Install policy: Nightlock can provide professional installation anywhere in the continental US.
 Nightlock is not responsible for failures or damage resulting from installation by customer or third party installer.

Subtotal	\$4,024.41
Sales Tax (0.0%)	\$0.00
Total	\$4,024.41

Phone # 855-644-4856 www.nightlock.com



Taylor Brothers Door Lock, LLC.

840 Tacoma Court
Clio, MI 48420-1581

Quote

Date	Estimate #
10/16/2025	11649

Name / Address
Livonia Public Schools ap@livoniapublicschools.org

Rep
CA

Description	Qty	Rate	Total
FOR: Niji-Iro			
LSSCU1592 Lockdown Safety Shade 15 in. W x 92 in. L	2	76.00	152.00
LSSCU0956 Lockdown Safety Shade 09 in. W x 56 in. L	2	27.75	55.50
LSSCU0945 Lockdown Safety Shade 09 in. W x 45 in. L	1	22.50	22.50
Shipping - Provided by Nightlock		0.00	0.00

Note: It is your responsibility to acquire any approvals needed from local code officials prior to installation. Make sure you inform local police and fire departments when locks are installed in their jurisdictions.
 Note: Refund Policy: If returning unused product, we offer a full refund minus freight costs and a 20% restocking fee. No returns or refunds on custom shades.
 Note: Install policy: Nightlock can provide professional installation anywhere in the continental US.
 Nightlock is not responsible for failures or damage resulting from installation by customer or third party installer.

Subtotal	\$230.00
Sales Tax (0.0%)	\$0.00
Total	\$230.00

Phone # 855-644-4856 www.nightlock.com



Taylor Brothers Door Lock, LLC.

840 Tacoma Court
Clio, MI 48420-1581

Quote

Date	Estimate #
10/16/2025	11659

Name / Address
Livonia Public Schools ap@livoniapublicschools.org

Rep
CA

Description	Qty	Rate	Total
FOR: Riley LSSCU2484 Lockdown Safety Shade 24 in. W x 84 in. L	5	86.75	433.75
LSSCU4184 Lockdown Safety Shade 41 in. W x 84 in. L	2	148.25	296.50
LSSCU3984 Lockdown Safety Shade 39 in. W x 84 in. L	1	141.00	141.00
LSS2642 Lockdown Safety Shade 26 in. W x 42 in. L	2	35.99	71.98
LSSCU3880 Lockdown Safety Shade 38 in. W x 80 in. L	2	130.75	261.50
LSSCU2480 Lockdown Safety Shade 24 in. W x 80 in. L	5	105.75	528.75
LSSCU3874 Lockdown Safety Shade 38 in. W x 74 in. L	1	121.00	121.00
Shipping - Provided by Nightlock		0.00	0.00

Note: It is your responsibility to acquire any approvals needed from local code officials prior to installation. Make sure you inform local police and fire departments when locks are installed in their jurisdictions.
 Note: Refund Policy: If returning unused product, we offer a full refund minus freight costs and a 20% restocking fee. No returns or refunds on custom shades.
 Note: Install policy: Nightlock can provide professional installation anywhere in the continental US.
 Nightlock is not responsible for failures or damage resulting from installation by customer or third party installer.

Subtotal	\$1,854.48
Sales Tax (0.0%)	\$0.00
Total	\$1,854.48

Phone # 855-644-4856 www.nightlock.com



Taylor Brothers Door Lock, LLC.

840 Tacoma Court
Clio, MI 48420-1581

Quote

Date	Estimate #
10/16/2025	11658

Name / Address
Livonia Public Schools ap@livoniapublicschools.org

Rep
CA

Description	Qty	Rate	Total
FOR: Roosevelt LSS1236 Lockdown Safety Shade 12 in. W x 36 in. L	3	19.99	59.97
LSS2636 Lockdown Safety Shade 26 in. W x 36 in. L	7	32.99	230.93
Shipping - Provided by Nightlock		0.00	0.00

Note: It is your responsibility to acquire any approvals needed from local code officials prior to installation. Make sure you inform local police and fire departments when locks are installed in their jurisdictions.
 Note: Refund Policy: If returning unused product, we offer a full refund minus freight costs and a 20% restocking fee. No returns or refunds on custom shades.
 Note: Install policy: Nightlock can provide professional installation anywhere in the continental US.
 Nightlock is not responsible for failures or damage resulting from installation by customer or third party installer.

Subtotal	\$290.90
Sales Tax (0.0%)	\$0.00
Total	\$290.90

Phone # 855-644-4856 www.nightlock.com



Taylor Brothers Door Lock, LLC.

840 Tacoma Court
Clio, MI 48420-1581

Quote

Date	Estimate #
10/16/2025	11655

Name / Address
Livonia Public Schools ap@livoniapublicschools.org

Rep
CA

Description	Qty	Rate	Total
FOR: Rosedale LSSCU3476 Lockdown Safety Shade 34 in. W x 76 in. L	2	111.25	222.50
LSSCU9350 Lockdown Safety Shade 93 in. W x 50 in. L	2	200.00	400.00
LSSCU3082 Lockdown Safety Shade 30 in. W x 82 in. L	8	106.00	848.00
LSSCU1476 Lockdown Safety Shade 14 in. W x 76 in. L	1	55.50	55.50
LSSCU1852 Lockdown Safety Shade 18 in. W x 52 in. L	1	51.50	51.50
LSSCU3247 Lockdown Safety Shade 32 in. W x 47 in. L	1	82.75	82.75
LSS0836 Lockdown Safety Shade 08 in. W x 36 in. L	1	15.99	15.99
LSSCU1852 Lockdown Safety Shade 18 in. W x 52 in. L	2	51.50	103.00
Shipping - Provided by Nightlock		0.00	0.00

Note: It is your responsibility to acquire any approvals needed from local code officials prior to installation. Make sure you inform local police and fire departments when locks are installed in their jurisdictions.
 Note: Refund Policy: If returning unused product, we offer a full refund minus freight costs and a 20% restocking fee. No returns or refunds on custom shades.
 Note: Install policy: Nightlock can provide professional installation anywhere in the continental US.
 Nightlock is not responsible for failures or damage resulting from installation by customer or third party installer.

Subtotal	\$1,779.24
Sales Tax (0.0%)	\$0.00
Total	\$1,779.24



Taylor Brothers Door Lock, LLC.

840 Tacoma Court
Clio, MI 48420-1581

Quote

Date	Estimate #
10/16/2025	11668

Name / Address
Livonia Public Schools ap@livoniapublicschools.org

Rep
CA

Description	Qty	Rate	Total
FOR: Stevenson LSS2642 Lockdown Safety Shade 26 in. W x 42 in. L	4	35.99	143.96
LSS1242 Lockdown Safety Shade 12 in. W x 42 in. L	10	20.99	209.90
LSS1242 Lockdown Safety Shade 12 in. W x 42 in. L	4	20.99	83.96
LSSCU1250 Lockdown Safety Shade 12 in. W x 50 in. L	2	33.00	66.00
LSS1236 Lockdown Safety Shade 12 in. W x 36 in. L	20	19.99	399.80
LSS1242 Lockdown Safety Shade 12 in. W x 42 in. L	20	20.99	419.80
Shipping - Provided by Nightlock		0.00	0.00

Note: It is your responsibility to acquire any approvals needed from local code officials prior to installation. Make sure you inform local police and fire departments when locks are installed in their jurisdictions.
 Note: Refund Policy: If returning unused product, we offer a full refund minus freight costs and a 20% restocking fee. No returns or refunds on custom shades.
 Note: Install policy: Nightlock can provide professional installation anywhere in the continental US.
 Nightlock is not responsible for failures or damage resulting from installation by customer or third party installer.

Subtotal	\$1,323.42
Sales Tax (0.0%)	\$0.00
Total	\$1,323.42



Taylor Brothers Door Lock, LLC.

840 Tacoma Court
Clio, MI 48420-1581

Quote

Date	Estimate #
10/16/2025	11661

Name / Address
Livonia Public Schools ap@livoniapublicschools.org

Rep
CA

Description	Qty	Rate	Total
FOR: Webster LSSCU3698 Lockdown Safety Shade 36 in. W x 98 in. L	13	151.75	1,972.75
LSSCU3969 Lockdown Safety Shade 39 in. W x 69 in. L	10	115.75	1,157.50
LSSCU2085 Lockdown Safety Shade 20 in. W x 85 in. L	4	93.50	374.00
LSSCU3183 Lockdown Safety Shade 31 in. W x 83 in. L	6	110.75	664.50
LSSCU3564 Lockdown Safety Shade 35 in. W x 64 in. L	2	96.50	193.00
LSSCU2889 Lockdown Safety Shade 28 in. W x 89 in. L	2	107.25	214.50
Shipping - Provided by Nightlock		0.00	0.00

Note: It is your responsibility to acquire any approvals needed from local code officials prior to installation. Make sure you inform local police and fire departments when locks are installed in their jurisdictions.
 Note: Refund Policy: If returning unused product, we offer a full refund minus freight costs and a 20% restocking fee. No returns or refunds on custom shades.
 Note: Install policy: Nightlock can provide professional installation anywhere in the continental US.
 Nightlock is not responsible for failures or damage resulting from installation by customer or third party installer.

Subtotal	\$4,576.25
Sales Tax (0.0%)	\$0.00
Total	\$4,576.25

Phone # 855-644-4856 www.nightlock.com



Taylor Brothers Door Lock, LLC.

840 Tacoma Court
Clio, MI 48420-1581

Quote

Date	Estimate #
10/16/2025	11669

Name / Address
Livonia Public Schools ap@livoniapublicschools.org

Rep
CA

Description	Qty	Rate	Total
FOR: Frost LSSCU3444 Lockdown Safety Shade 34 in. W x 44 in. L	2	82.50	165.00
LSSCU25544 Lockdown Safety Shade 25.5 in. W x 44 in. L	1	63.00	63.00
LSSCU2654445 Lockdown Safety Shade 26.5 in. W x 44.5 in. L	1	67.00	67.00
LSSCU52485 Lockdown Safety Shade 52 in. W x 48.5 in. L	2	109.75	219.50
LSSCU5240 Lockdown Safety Shade 52 in. W x 40 in. L	1	89.50	89.50
LSSCU51565 Lockdown Safety Shade 51 in. W x 56.5 in. L	8	125.25	1,002.00
LSSCU25544 Lockdown Safety Shade 25.5 in. W x 44 in. L	6	63.00	378.00
Shipping - Provided by Nightlock		0.00	0.00

Note: It is your responsibility to acquire any approvals needed from local code officials prior to installation. Make sure you inform local police and fire departments when locks are installed in their jurisdictions.
 Note: Refund Policy: If returning unused product, we offer a full refund minus freight costs and a 20% restocking fee. No returns or refunds on custom shades.
 Note: Install policy: Nightlock can provide professional installation anywhere in the continental US.
 Nightlock is not responsible for failures or damage resulting from installation by customer or third party installer.

Subtotal	\$1,984.00
Sales Tax (0.0%)	\$0.00
Total	\$1,984.00



Livonia Public Schools

District Services

Date: November 7, 2025

To: Andrea Oquist, Superintendent

From: William Green, Assistant Superintendent of Operations and District Services

Re: Purchase of Physical Education and Field House Fans

I respectfully request that an agenda item be added to the November 10, 2025, Committee of the Whole Meeting to discuss the proposed purchase of portable fans from Big Ass Fans, located in Lexington, KY.

Background

This purchase is intended to enhance air circulation and comfort across physical education classrooms and field houses at the Upper Elementary, Middle School and High Schools. The investment will support improved air movement and temperature regulation in instructional and athletic spaces, particularly during warmer months or when HVAC performance is limited.

Recommendation

The proposed purchase includes:

- Three portable fans for Upper Elementary Schools: Riley, Johnson, and Cooper at a total cost of \$18,729.
- Six portable fans for Holmes, Emerson, and Frost Middle Schools at a total cost of \$37,458.
- Nine portable fans for the competitive gyms and field houses at Stevenson, Churchill, and Franklin High Schools at a total cost of \$56,187.

The total cost for this purchase is \$113,874, which includes an estimated \$1,500 for shipping, and will be funded through the General Fund.

Please include this item on the agenda. Thank you.

Attachment

c: Board of Education
WG/AS



Southfield 10PM

48076

What ca



Southfield 10PM

48076



Shop All Services



DIY



Log In

/ Heating, Venting & Cooling / Fans / Floor Fans / Big Ass Fans Floor Fans

Internet # 332755273 Model # F-BJ1-0601S34

Customers Also Viewed

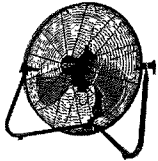

Commercial Electric 20 in 3-Speed High Velocity Floor Fan

★★★★★ (1314)

\$48⁵⁴

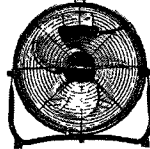

Admrfly 20 in 3-Speed High-Velocity Industrial Heavy-Duty Metal Floor Fan in

★★★★★ (6)

\$103⁶⁸

Sponsored

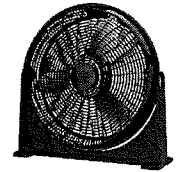

Lasko for Home

★★★★★

\$43



Need help? We are here to help! Click here to start a chat!

Big Ass Fans

BlackJack 6ft. Indoor/Outdoor HVLS Directional Fan in Black with Lockable All Terrain Wheels + Handles, Wash-Down Ready

88



★★★★★ (1) Questions & Answers (1)

\$7,450⁰⁰

\$1,242 00/mo** suggested payments with 6 months** financing Apply Now

Pickup at [Southfield](#)

Delivering to [48076](#)

<p>Ship to Store</p> <p>Oct 20 - Oct 23</p> <p>49 available</p> <p>FREE</p>	<p>Delivery</p> <p>Oct 20 - Oct 27</p> <p>49 available</p>
--	---

[Check Nearby Stores](#)

[Delivery Details](#)

Feedback

Protect This Item

Select a Home Depot Protection Plan by Allstate for

3 Year / \$500.00

No thanks

[What to Expect](#)

1	+
---	---

Add to Cart

rayrol

As low as \$401 37/mo with [PayPal](#) [Learn more](#)

Free & Easy Returns In Store or Online

Return this item within 90 days of purchase

[Read Return Policy](#)

Frequently Bought Together

CURRENT ITEM

Select

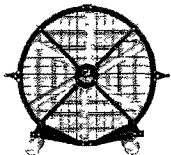

Big Ass Fans BlackJack 6ft

★★★★★ (1)

\$7,450⁰⁰

Select

Exclusive



Lasko Power Plus 20 in 3 Speed Box Fan ..

★★★★ (1652)

\$38⁴⁸

Select



Lasko 20 in 3 Speed Air Circulating Box F

★★★★ (3449)

\$24⁹⁸ /box

Subtotal: \$7,513⁴⁶

Add 3 Items to Cart



Ask about this product

Get an immediate answer with AI

Ask a question

Get an Answer

AI-generated from the text of manufacturer documentation. To verify or get additional information, please contact The Home Depot customer service.

Product Details

Specifications

Dimensions H 78 in, W 84 in, D 29 in

Dimensions

Fan diameter (in.)	73 in
Product Depth (in.)	29 in
Product Height (in.)	78 in
Product Width (in.)	84 in

Details

CFM	0
Color Family	Black
Color/Finish	Black
Control Type	Fan Control
Cord Length (ft.)	25 ft
Decibel (Sound) Rating	78 dBA
Fan Diameter (in.)	Greater than 30
Fan Features	Grounded, High Velocity, Portable, Power Cord Compartment, Reversible, Wheels, with Handle
Fan Type	Floor Fan
Indoor/Outdoor	Indoor/Outdoor
Number of Fan Speeds	Variable Speeds
Number of Fan Speeds	Variable Speeds
Plug Type	GFCI
Power Type	Plug-In
Returnable	90-Day
Voltage (volts)	120

Warranty / Certifications

Certifications and Listings

88 AMCA Certified, CE Certified, ETL Certified, OSHA Certified, SGS Certified, cETLus

Feedback



Southfield 10PM 48076 What ca



Southfield 10PM 48076

Shop All Services

DIY

Log In

CART (18)

Share

[Remove All Items](#)

Delivery

Delivering to [48076](#) (1 item)

Your Delivery Cost **\$55.00**

This cost covers all Delivery items in your cart

Feedback

Big Ass Fans

BlackJack 6ft Indoor/Outdoor HVLS Directional Fan in Black with Lockable All Terrain Wheels + Handles, Wash-Down Ready

Model #F-BJ1-0601S34

\$134,100.00
(\$7,450.00/item)

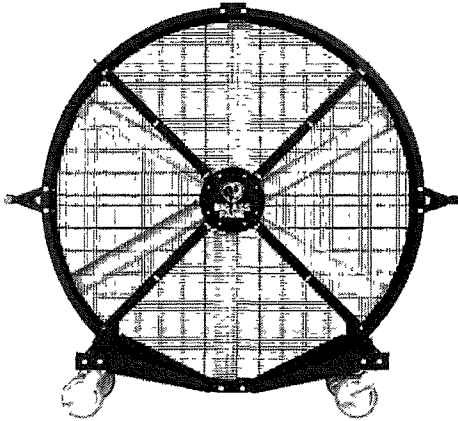

- 18 +

Recently Viewed

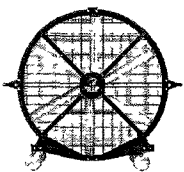

Big Ass Fans BlackJack
6ft Indoor/Outdoor

★★★★★ (1)

\$7,450⁰⁰

Add to Cart

Customers Also Purchased...

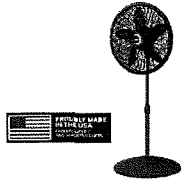

Lasko Cyclone 18 in 3 Speed Oscillating

★★★★ (4904)

\$43⁹⁸

Add to Cart

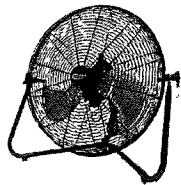

Commercial Electric 20 in 3-Speed High

★★★★☆ (1314)

\$48⁵⁴

Add to Cart



Lasko 20 in 3 Speed Air Circulating Box Fan fo

★★★★ (3449)

\$24⁹⁸ /box

Add to Cart

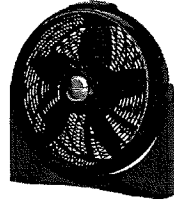

Lasko Cyclone 20 in 3 Speed Air Circulator

★★★★☆ (2117)

\$39⁹⁸

Add to Cart

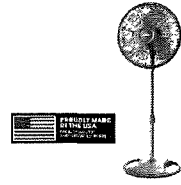

Lasko 16 in 3 Speed Oscillating Pedestal F

★★★★ (2646)

\$29⁹⁸

Add to Cart

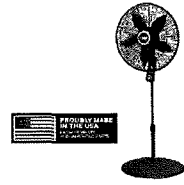

Lasko 20 in 4 Speed Oscillating Pedestal F .

★★★★ (1751)

\$73⁰⁷

Add to Cart

L S \$ \$

Feedback

Loading Recommendations

Loading Recommendations

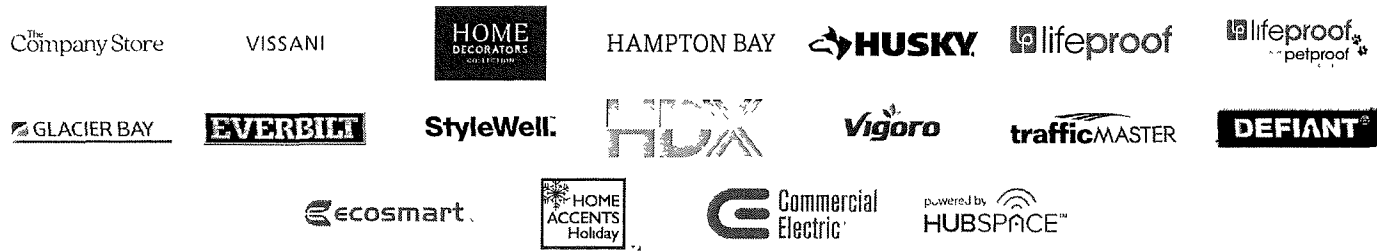

Need Help?

Visit our [Customer Service Center](#) or Text 38698

[Store Locator](#) | [©2000-2025 Home Depot](#) | [Privacy & Security Statement](#) | [Terms](#) | [My Preference Center](#) | [California Privacy Rights & Report](#) | [Limit the Use of My Sensitive Personal Information](#) | [Do Not Sell or Share My Personal Information](#) | [California Supply Chain Act](#)

[Provide Feedback](#)

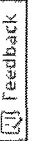



Enter a keyword or part number



Track Order

Sign In/Register

149,382.00

SHOP ALL CATEGORIES

SHOP BY INDUSTRY

EXCLUSIVE BRANDS

NEW PRODUCTS

EXPLORE SOLUTIONS

CATALOG

DEALS

Back to shopping

Share Print

Shopping Cart (18)

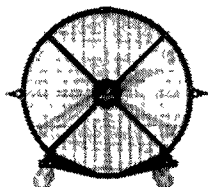

Big Ass Fans Black Jack, 72" Portable Barrel Fan

Model # WBB312700

Please Note This Item is For Lo Drumed

18

\$149,382.00 (\$8,299.00/unit)

Add to list | Save for later | Remove

Your Cart Summary

Item Total: \$149,382.00
Subtotal: \$149,382.00

Calculate Shipping

Zipcode

Enter zipcode

Total: \$149,382.00

Taxes are calc during checkout

Have A Promo Code? 92

Enter promo code

Apply

Checkout

Get Quote

Products Related To Items In Your Cart

EXCLUSIVE BRANDS



Global Industrial™ Industrial Duty Manual Pallet Jack 5500 lb

Model # W6334475

392

\$395.95

1

Add

Ships Same Day



GoGreen Power, 12/3 50' 3-Outlet Heavy Duty Extension Cord GG-

Model # W882077532

\$75.95

1

Add

Ships within 1 Business Day

Questions about your order?

Cart id # 0587341441

Call Us 1.888.978.7759 or Chat

Shopping Cart (18)

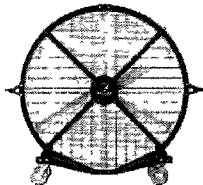

Big Ass Fans Black Jack, 72" Portable Barrel Fan

Model # WBB3112709

18

\$149,382.00
(\$8,299.00/unit)

[Save for later](#)

[Remove](#)

 Please Note This item cannot be returned

Products Related To Items In Your Cart

Your Cart Summary

Item Total \$149,382.00

Subtotal \$149,382.00

Zipcode

Enter zipcode



Total \$149,382.00

Taxes are calculated during checkout

Enter promo code



PROPOSAL

Livonia Public School District

QUOTE NUMBER: 01111313

THE ULTIMATE AIRFLOW SOLUTION

For more than 20 years, Big Ass Fans has set the standard for safer, more comfortable work conditions with airflow products purpose-built to excel in demanding environments. Our fans provide year-round relief from extreme temperatures, making people feel up to 10 °F (6 °C) cooler in summer and effectively circulating heated air in winter.

Engineered for efficient, maintenance-free operation and backed by unbeatable warranties, Big Ass fans deliver powerful airflow that keeps workers refreshed and productive. With a custom solution from Big Ass Fans, your business will reap the rewards of comfort and cost-savings for years.

Contact: **Jon West**

Email: jon.west@bigassfans.com

Phone: **(859) 629-7585**

Quote Information

Quote Number	01111313	Created Date	11/10/2025
		Expiration Date	12/10/2025
Bill To Name	Livonia Public School District	Ship To Name	Livonia Public School District
Bill To:	15125 Farmington Rd Livonia, MI 48154 US	Ship To:	15125 Farmington Rd Livonia, MI 48150 US
SFDC ID	11099741		

General Information

Sales Rep	Jon West	Contact Name	AP Livonia Public Schools
E-mail	jon.west@bigassfans.com	Contact Phone	(734)744-2554
Phone	(859) 629-7585		
Fax	859-233-0139		

Comments

Comments

Sales Tax

Sales Tax is strictly an estimate and may change based on the shipping address of the order; sales tax is also subject to the tax provisions of the "STANDARD TERMS."

Product	Description	Qty	Total Price
Black Jack, 6 ft, 120 V 1 Phase, Portable Fan, 25 ft. cord - Tariff Surcharge, Directional Fans (\$95, included)	Upper Elementary Schools (Riley, Johnson, Cooper)	3	\$18,729.00
Black Jack, 6 ft, 120 V 1 Phase, Portable Fan, 25 ft. cord - Tariff Surcharge, Directional Fans (\$570, included)	Middle Schools (Holmes, Emerson, Frost)	6	\$37,458.00
Black Jack, 6 ft, 120 V 1 Phase, Portable Fan, 25 ft. cord - Tariff Surcharge, Directional Fans (\$855, included)	High Schools Competitive Gyms and Field Houses (SHS, FHS, CHS)	9	\$56,187.00
			Subtotal: \$112,374.00
			Tax: \$ 0.00
			Estimated Shipping: \$1,500.00
			Grand Total: \$113,874.00

STANDARD TERMS - NET 30 DAYS UPON APPROVAL

Shipping and handling is an estimate.

Our proposals include an estimate of applicable itemized sales taxes which Big Ass Fans is legally obligated to collect and remit. The final, actual amount of such taxes would only be known at the time the customer is actually invoiced for the order.

Prices are subject to change without notice. Surcharges and/or Tariffs may be added or revised at any time and without notice.

All products are subject to Big Ass Fans return policy. For full details visit bigassfans.com/returns

The Buyer must insure that product specifications are consistent with actual field installation requirements. Big Ass Fans product recommendations are based on product specifications as transmitted to the company. As such, Big Ass Fans is not responsible for inaccuracies between the communicated product specifications and actual field installation requirements. The Buyer of the specified products assumes responsibility for the cost of returning or exchanging specified product where specified product does not meet field requirements.

Any variations to product types or quantities (or omissions of existing light fixtures during the survey process – and now not represented in project) will be considered “add-on” and an additional material requirement. These add-on materials will be priced separately.

Big Ass Fans customers who have been approved for term credit and are invoiced for their orders may pay their invoice through one of our customary term credit payment methods of: Check, money order, wire transfer or ACH payment. Any such term credit approved customers who subsequently elect to pay their term invoice by credit card will also be charged a convenience fee for doing so. The exact amount of the convenience fee will be communicated to the customer before the transaction is processed and the card is charged. The Fee is calculated by multiplying the amount sought to be charged to the credit card by .03. (Fee = .03 x Total Amount Paid). If the customer elects not to pay the convenience fee, the customer may use one of the other payment channels alluded to above, free of charge.

Customer is responsible for paying all applicable state and local transactional taxes resulting from the sale. As a manufacturer of tangible personal property registered to do business in all 50 US States, Big Ass Fans is obligated to collect and remit applicable sales taxes and the transaction will be treated and reported as the sale of tangible personal property sold by a manufacturer.

Notwithstanding any provision to the contrary, neither party shall be liable to the other party (or any third party) for indirect, consequential, special, incidental, or punitive damages arising from the sale of the products or this agreement. In addition, seller's total aggregate liability under this agreement shall never exceed the value of the purchase order or the previous twelve (12) months of sales hereunder, whichever is less. This provision shall survive the expiration of termination of this agreement.

INTELLECTUAL PROPERTY

Big Ass Fans retains exclusive ownership of all intellectual property rights embodied by and/or associated with the products sold.

To the extent that the Buyer takes any contrary position with any taxing authority subsequent to this transaction which results in additional and/or different transaction-based taxes for which Big Ass Fans is responsible, Big Ass Fans reserves the right to apply any sales tax collected to any such additional taxes due and/or invoice the Buyer for any other additional amounts due. Additionally, to the extent that applicable transactional taxes were not collected at the time of sale in reliance upon an Exemption Certificate or other exemption later found to be inapplicable by Big Ass Fans, in the exercise of its sole and absolute discretion, Big Ass Fans will invoice Buyer for any applicable sales or other transactional taxes.

Buyer covenants and agrees to promptly pay any such amounts to Big Ass Fans on the same terms and conditions as any other amounts owed to Big Ass Fans on the applicable Order.

The transaction and contract that is the subject of this Proposal shall be governed by the internal laws of the Commonwealth of Kentucky. Any controversy or claim arising out of or relating to this contract, or the breach thereof, shall be settled by arbitration administered by the American Arbitration Association in accordance with its Commercial Arbitration Rules, and judgment on the award rendered by the arbitrator(s) may be entered in any court having jurisdiction thereof.

Upon sales agreement being signed and submitted, order shipment date changes may not be submitted or changed by the purchasing party within 10 business days of scheduled shipment. Scheduled shipment dates may not be changed within the final 10 business days of a given month. Should a customer require that a shipment date be changed within 10 business days of scheduled shipment or within the final 10 business days of a given month, Big Ass Fans reserves the right to decline the customer's request. Secondly, Big Ass Fans reserves the right to charge a monetary fee for any shipment date change request that falls within the representative windows described above. Reconsignment fees are as follows: \$50 for small diameter fan orders and \$500 for large overhead orders.

Evaporative Cooler (Cool-Space) orders are not able to be canceled outside of the same business day in which purchase has been confirmed. Customer assumes responsibility for all necessary reconsignment fees related to shipping &/or freight charges as a result of canceled orders completed outside of the hours of 8:00AM to 5:00PM EST on the same business day purchase occurs.

This Proposal and its Associated Terms may not be modified or added to, except by a subsequent writing executed by Big Ass Fans.

PURCHASING OR USING ANY OF OUR PRODUCTS & SERVICES INDICATES YOU AGREE WITH OUR [TERMS OF SERVICE](#) AND [PRIVACY POLICY](#). (FOR FULL WARRANTY, TERMS, AND CONDITIONS FOR ALL BIG ASS PRODUCTS, VISIT BIGASSFANS.COM)

BLACK JACK[®]

With an unrivaled balance of airflow and mobility, Black Jack belongs in every facility. Offering a fully assembled steel frame and 25-foot (7.6-meter) power cord that fits any standard outlet, it's the durable and convenient choice for your dynamic airflow needs. Best of all, Black Jack's powerful IPX5-rated motor runs quietly and efficiently, keeping your people comfortable without distraction.



KEY FEATURES

- ▶ **Six aluminum airfoils** with winglets in an OSHA-compliant cage
- ▶ **Powerful airflow** provides coverage up to 120 feet (37 meters) away
- ▶ **Quiet, efficient EC motor** with variable speed control
- ▶ **Perfectly sized** to fit through standard interior doorways
- ▶ **Maneuvers indoors or out** with durable rubber wheels and handles
- ▶ **Arrives pre-assembled** and ready for operation

DIAMETER

6.5 FEET
(2.0 METERS)

FRAME

OSHA-COMPLIANT STEEL CAGE
WITH ALL-TERRAIN RUBBER WHEELS

VOLTAGE

110-125 OR 200-240
SINGLE PHASE VAC

WARRANTY

UP TO
5 YEARS



DISCOVER MORE ABOUT BLACK JACK

Learn more at bigassfans.com/black-jack
98 or call **877.BIG.FANS** for a free custom quote.

BLACK JACK

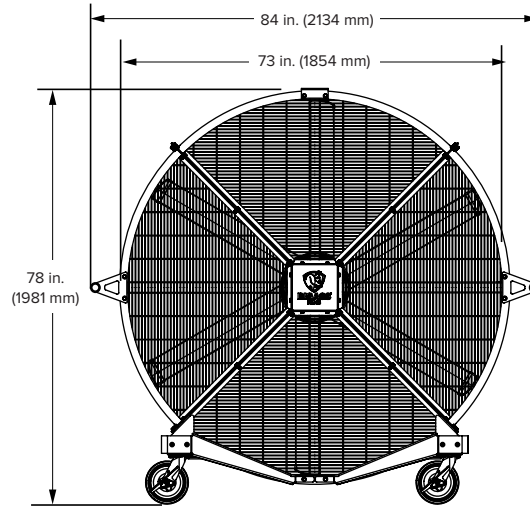
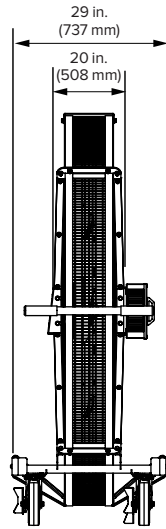

POWERFUL AIRFLOW THAT'S A BREEZE TO MANEUVER.



Technical Specifications

Input power and required breaker	Amperage	Wattage	Operating Temperature	Sound at max speed ¹	Weight
110–125 VAC, 50/60 Hz, 1 Φ, 15 A	7.8–7.1 A	473 W	-4°F to 131°F (-20°C to 55°C)	78.2 dBA	310 lb (141 kg)
200–240 VAC, 50/60 Hz, 1 Φ, 10 A	5.6–4.6 A	466 W			

Construction Features

Cage and Frame	Motor and Controller	Power Supply	Environment	Certifications	Colors
Preassembled 6.5 ft (2 m) steel frame OSHA-compliant cage All-terrain wheels with rubber treads	Direct drive ECM motor Variable speed control	25 ft (7.6 m) cord with plug fits standard power outlet Optional 10 ft (3 m) cord available	IPX5 for indoor or outdoor use Washdown construction	 UL Standard 507 and CSA Standard 22.2 No. 113 	Black Custom colors available

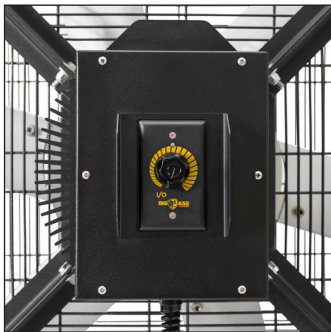

¹ Not suitable for salt air environments.

² Fans are sound tested at maximum speed in a laboratory environment. Actual results in field conditions may vary due to sound reflecting surfaces and environmental conditions.

Lead times may vary. See full warranty for coverage information.



USA
BIGASSFANS.COM
877-244-3267

CANADA
BIGASSFANS.COM
844-924-4277

AUSTRALIA
BIGASSFANS.COM/AU
1300 244 277

SINGAPORE
BIGASSFANS.COM/SG
65 6709 8500

MALAYSIA
BIGASSFANS.COM/SG
603 5565 0888

BLACK JACK



AIRFLOW

AIRFLOW VELOCITY

The three lines show air velocity from the center of the fan at three sensors of varying height.

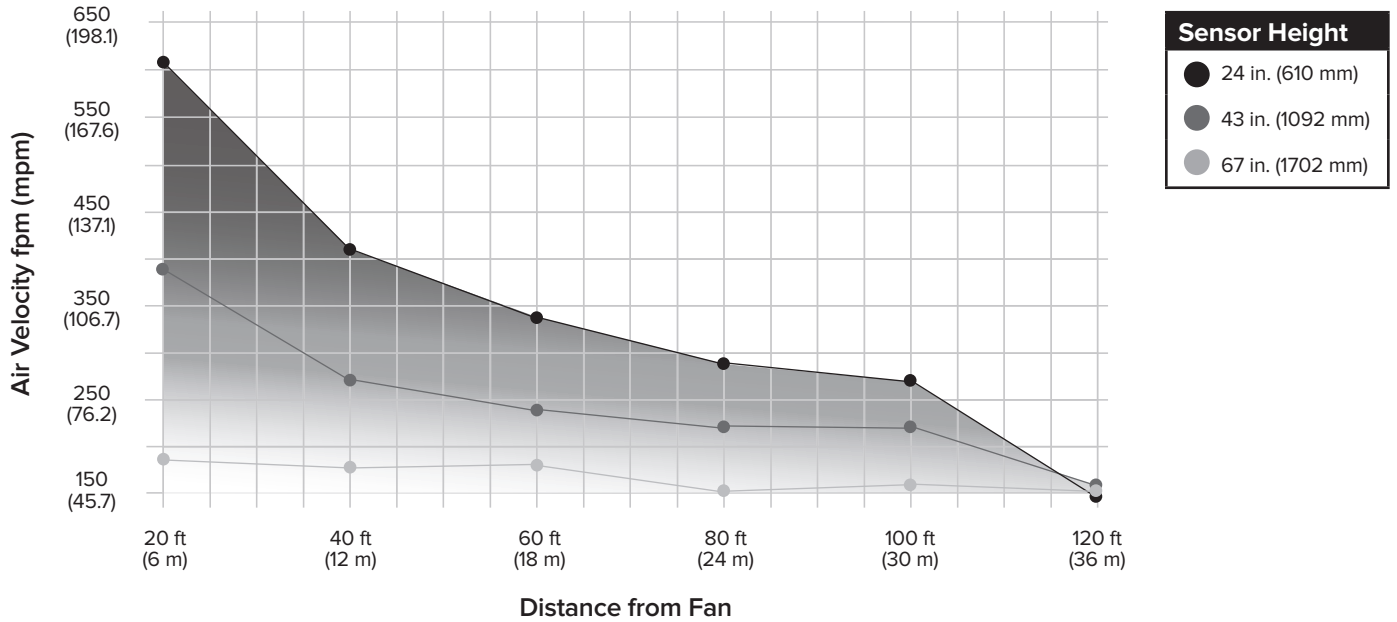

AIRFLOW DISTANCE

Shaded areas represent cooling up to 120 feet (36.6 meters). That's one-third the length of a football field! Darker shading indicates faster air velocity.

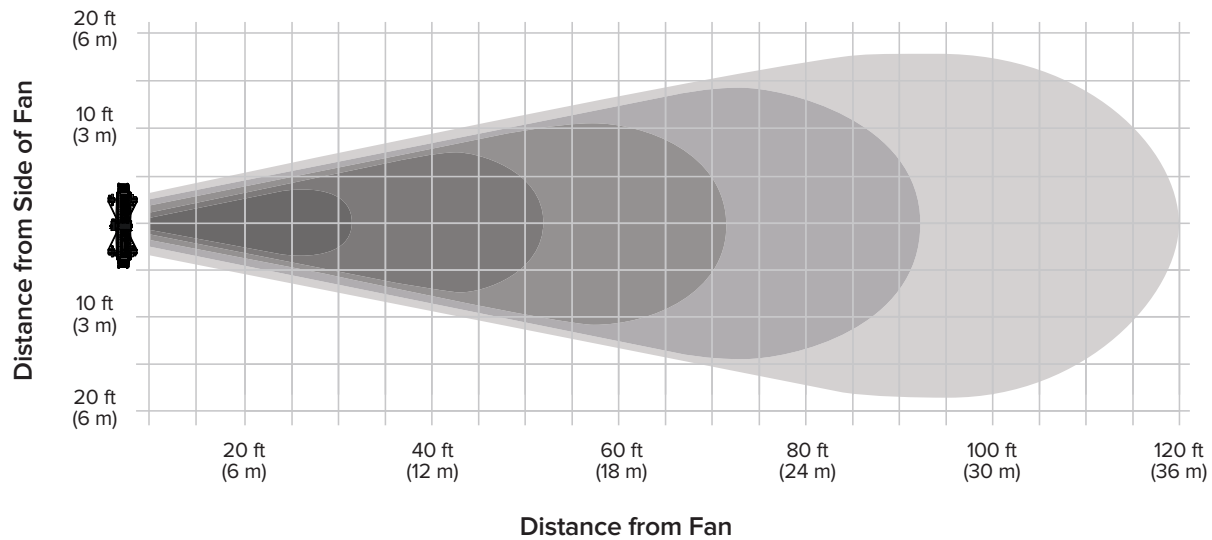

USA
BIGASSFANS.COM
877-244-3267

CANADA
E1(4)S3FANS.COM
844-924-4277

AUSTRALIA
BIGASSFANS.COM/AU
1300 244 277

SINGAPORE
BIGASSFANS.COM/SG
65 6709 8500

MALAYSIA
BIGASSFANS.COM/SG
603 5565 0888



Date: November 7, 2025

To: Andrea Oquist, Superintendent

From: William Green, Assistant Superintendent of Operations and District Services

Re: Purchase of District Generator for Central Office Complex

I would like to request adding an agenda item to the November 10, 2025, Committee of the Whole Meeting to discuss the bids for the Central Office Generator.

Background

The existing generator at the Central Office building is over 20 years old and only provides limited backup power during outages, supporting only a portion of the facility. The proposed replacement is a larger, stationary generator designed to supply full backup power to the entire building, ensuring that all critical operations can continue uninterrupted during power failures. This upgrade will significantly enhance the district's emergency preparedness and operational reliability. The current generator will remain in place as a secondary backup, offering additional support if needed for the system.

Recommendation

Following the release of construction documents and a formal bidding process, six proposals were received and carefully reviewed by the project team, which includes representatives from Plante Moran Realpoint, French Associates, and Livonia Public Schools. Based on thorough evaluation, the team recommends awarding the contract to Innovated Energy Controls LLC, Howell, Michigan, as the lowest responsible bidder. The total recommended project cost is \$435,000, which includes \$395,500 for construction and a \$39,500 contingency to cover any unforeseen expenses.

Please add this request to the agenda for the Committee of the Whole, Monday, November 10, 2025.

Attachments

WG/AS

c: Board of Education

November 4, 2025

Mr. William Green
Assistant Superintendent of District Services
Livonia Public Schools
15125 Farmington Road
Livonia, MI 48154

RE: Sinking Fund Projects
Contract Award Recommendation for Central Office Generator Upgrade

Dear Mr. Green:

This letter transmits an update from Plante Moran Realpoint (PMR) as it relates to the assignment to assist and advise Livonia Public Schools (LPS) in its selection of a Prime Contractor for the Project listed above. This update represents the mutual efforts of PMR, French Associates, LPS administration and staff (the Team) to present a framework in order to identify, evaluate and recommend a Prime Contractor firm for this Project.

On September 19, 2025, Construction Documents were formally issued and made available. An advertisement for bids was published in a local newspaper and also posted to the required State of Michigan website.

On October 30, 2025, six (6) bid proposals were received for the Project and were reviewed and evaluated by the team. Post bid interviews with the 3 apparent low bidders were conducted over the course of the following days, with various members of the Team participating. The scope of work, schedule, and other particulars regarding the work were reviewed and clarified.

Upon completion of the interviews, and after subsequent clarifications and discussions, the Team is **recommending Innovated Energy Controls LLC** for contract award as the lowest responsible bidder for the Project.

Including hard construction of \$395,500.00 and construction contingency of \$39,500.00, the total Project award **recommendation equals \$435,000.00.**

For the Prime Contractor, the costs for this work will be detailed in AIA Contract A105 – 2017 Standard Form of Agreement between Owner and Contractor, pending final review and approval of terms by district legal counsel.

The Team is available at the Board’s convenience to answer any questions regarding bidding, the proposals, interview process, or the recommendation herein. Please direct all questions through me via email at collin.frink@plantemoran.com.

Sincerely,

PLANTE MORAN REALPOINT



Collin Frink
Vice President

Enclosures: Cost Summary
Bid Tabulation



**SINKNG FUND
CENTRAL OFFICE COMPLEX GENERATOR UPGRADES
COST SUMMARY**

	Hard Construction		
Project	Budget	Actual	Variance
Central Office Generator Upgrades	\$ 1,000,000	\$ 395,500	\$ 604,500
Totals	\$ 1,000,000	\$ 395,500	\$ 604,500
	Construction Contingency		
	Budget (10%)	Actual (10%)	Variance
Project Contingency	\$ 100,000	\$ 39,500	\$ 60,500
Totals	\$ 100,000	\$ 39,500	\$ 60,500
	Total Project Costs		
	Budget	Actual	Variance
Project Total	\$ 1,100,000	\$ 435,000	\$ 665,000
Totals	\$ 1,100,000	\$ 435,000	\$ 665,000

Proposal: Central Office Generator

Location: Livonia Public Schools Central Office

Date: October 30, 2025

Contractor Name	Bid Security	Bid Formality							Base Bid Amounts	Comments / Voluntary Alternates
		EOE	Fam. Dis.	Iran	Addendum 1	Addendum 2	Addendum 3	Addendum 4		
J Ranck Electric, Inc.	X	X	X	X	X	X	X	X	\$ 476,577	Voluntary Alternate Submitted
O'Donnel Electric	X	X	X	X	X	X	X	X	\$ 421,000	
Greenline Electric	X	X	X	X	X	X	X	X	\$ 510,000	
Innovated Energy Controls	X	X	X	X	X	X	X	X	\$ 395,500	
Spartan Construction	X	X	X	X	X	X	X	X	\$ 469,000	Voluntary Alternate Submitted
Douglas Electric	X	X	X	X	X	X	X	X	\$ 423,445	



Livonia Public Schools

Instructional Services

Date: November 7, 2025

To: Andrea Oquist, Superintendent

From: Jennifer Keatts, Asst. Superintendent of Elementary Programs and Instructional Services
Kevin Etue, Director of Secondary Programs and District Services

Subject: Board Policy and Administrative Procedures: JD – Personal Electronic Devices

We are requesting to continue discussions with the Board following our most recent Study Session on Board Policy and Administrative Procedures: JD Students- Personal Electronic Devices

Please include this item on the November 10, 2025, Board Policy Committee meeting agenda. As always, please let us know if you have any questions.

Attachments

JK/KE/tg

BOARD POLICY

JD

STUDENTS STUDENT CODE OF CONDUCT

~~May 2, 2022~~
DECEMBER 15, 2025

PERSONAL ELECTRONIC COMMUNICATION DEVICES

Personal electronic devices such as cell phones, tablets, laptops, smartwatches, e-readers, and any device capable of sending, receiving, or storing digital data are permitted on school property.

~~Personal E~~lectronic communication devices (ECDs) such as cell phones, tablets, computers, and any/all other forms of technology will **not** be permitted for use **during instructional time** **unless** as approved by the classroom teacher or the building **school** administration. Students may not use ECDs on school property or during school sponsored activities to access and/or view internet websites that are otherwise blocked or prohibited for students at school.

In accordance with the district's LIVNET policy (appropriate use of technology), use of personal electronic devices to access or view internet content that is blocked or prohibited for students is not allowed on school property or during school-sponsored activities.

See Administrative Procedures - JD - Personal Electronic Devices for additional information.

ADMINISTRATIVE PROCEDURES

JD

PERSONAL ELECTRONIC DEVICES

DECEMBER 2025

These administrative procedures are established to provide clear guidelines for the responsible use of personal electronic devices by students to support a safe, respectful, and productive learning environment. These administrative procedures apply to all students on school property and participating in school-sponsored activities.

Personal Electronic Devices: Includes cell phones, tablets, laptops, smartwatches, e-readers, and any device capable of sending, receiving, or storing digital data.

Instructional Time: Periods during which students are engaged in classroom learning or school-sponsored educational activities.

Grade Band Rules:

- Lower Elementary (PreKindergarten-Fourth Grade)
 - Students are not to use electronic items including cell phones, smart watches, tablets, etc. in school unless authorized by the building administration/ appropriate staff and building protocol for electronics has been followed.
 - Administration recognizes that electronic devices are a desirable and convenient means of communication between parents and their children. Thus, authorized electronic device use is defined below:
 - Electronic devices are not to be turned on, seen, heard, or used in the school building without permission.
 - The school is not responsible for lost, stolen, or damaged electronic devices.
 - Carrying electronic devices on the student is not allowed without staff permission.
 - Personal electronic devices with tracking capabilities/GPS may be used for your student's safety. However, these devices have the capability to record sound which is not allowed in the school building or classroom. The device can be used as a GPS, but the audio option must be turned off. See LPS Board Policy, JD - Student Code of Conduct, Recording Without Permission for further details.

- See the school's student handbook for consequences and further details.
- Upper Elementary (Fifth and Sixth Grade)
 - Students are not to use electronic items including cell phones, smart watches, tablets, etc. in school unless authorized by the building administration/ appropriate staff and building protocol for electronics has been followed.
 - Administration recognizes that electronic devices are a desirable and convenient means of communication between parents and their children. Thus, authorized electronic device use is defined below:
 - Electronic devices are not to be turned on, seen, heard, or used in the school building without permission.
 - The school is not responsible for lost, stolen, or damaged electronic devices.
 - Carrying electronic devices on the student is not allowed without staff permission.
 - Personal electronic devices with tracking capabilities/GPS may be used for student's safety. However, these devices have the capability to record sound which is not allowed in the school building or classroom. The device can be used as a GPS, but the audio option must be turned off. See LPS Board Policy, JD - Student Code of Conduct, Recording Without Permission for further details.
 - See the school's student handbook for consequences and further details.
- Middle School (Seventh and Eighth Grade)
 - Personal electronic devices may be used before and after school hours.
 - Personal electronic devices may not be used during lunch times unless approved by the school's administration.
 - Personal electronic devices may not be used in the hallway, at any time, or during instructional time unless explicit staff or school administration approval is granted.
 - During the school day, personal electronic devices should be stored in the student's locker unless approved by the school's administration to be carried or stored elsewhere.
 - Personal electronic devices with tracking capabilities/GPS may be used for student's safety. However, these devices have the capability to record sound which is not allowed in the school building or classroom. The device can be used as a GPS, but the audio option must be turned off. See LPS Board Policy, JD - Student Code of Conduct, Recording Without Permission for further details.

- See the school's student handbook for consequences and further details.
- High School (Ninth-Twelfth Grade)
 - Personal electronic devices may be used before and after school hours, during passing times, and at lunch.
 - During instructional time, personal electronic devices must be stored in the student's backpack or designated classroom space.
 - Personal electronic devices may not be used during instructional time or in the hallway during instructional time unless explicit staff or school administration approval is granted.
 - Personal electronic devices with tracking capabilities/GPS may be used for student's safety. However, these devices have the capability to record sound which is not allowed in the school building or classroom. The device can be used as a GPS, but the audio option must be turned off. See LPS Board Policy, JD - Student Code of Conduct, Recording Without Permission for further details.
 - See the school's student handbook for consequences and further details.
- Postsecondary (18-26 years old)
 - Students are permitted to bring cell phones and other personal electronic devices to school.
 - Personal electronic devices must be turned off and kept out of sight at all times, except during non instructional times as permitted by the teacher/administrator.
 - Personal electronic devices with tracking capabilities/GPS may be used for student's safety. However, these devices have the capability to record sound which is not allowed in the school building or classroom. The device can be used as a GPS, but the audio option must be turned off. See LPS Board Policy, JD - Student Code of Conduct, Recording Without Permission for further details.
 - See the school's student handbook for consequences and further details.

Prohibited Use:

- Unauthorized recording (audio, video, or photos) of staff or students.
- Use during assessments unless specified by accommodations or instructions.
- Use of devices for any form of, but not limited to, academic dishonesty, cyberbullying, harassment, unauthorized communication, or access to inappropriate, harmful, or restricted content.

Emergency Use:

- Staff may direct students to use devices if necessary for safety.

Privacy and Security:

- The school and district are not responsible for lost, stolen, or damaged devices.
- Students are expected to secure their devices and avoid sharing personal information.

Enforcement:

- School administrators and staff are authorized to enforce these procedures.
- Devices may be searched by school and/or district administration if there is reasonable suspicion of a violation of law or policy, in accordance with district and legal guidelines.

Exceptions:

- Students with documented accommodations (e.g., IEP, 504 plans, health care plan) may use devices as specified.
- Exceptions may be granted for medical or other approved reasons.



Date: November 7, 2025

To: Andrea Oquist, Superintendent

From: Maegan Sprow, Director of Student Services

Subject: Board Policy and Administrative Procedures: JAB – Nondiscrimination on the Basis of Disability – Section 504

I am requesting to continue discussions with the Board following our most recent Study Session on Board Policy and Administrative Procedures: JAB: Nondiscrimination on the Basis of Disability – Section 504

Please include this item on the November 10, 2025, Board Policy Committee meeting agenda. As always, please let me know if you have any questions.

Attachments

MS/tg

**BOARD POLICY
NONDISCRIMINATION ON THE
BASIS OF HANDICAP ~~DISABILITY~~- SECTION 504**

JAB

**~~JUNE 6, 2016~~
December 15, 2025**

The School District, in accordance with Section 504 of the Rehabilitation Act of 1973 and its implementing regulations, **the Americans with Disabilities Act (ADA), and applicable federal and state law**, is committed to providing a free appropriate education to each qualified ~~handicapped student with a disability~~ within its jurisdiction, regardless of the nature or severity of the ~~handicap disability~~.

The administrative rules establish the procedure in which the School District may meet this commitment. The School District may, as an alternative or in combination with this procedure, follow the provisions established for identification, evaluation, and placement of students under the Individuals with Disabilities in Education Act (IDEA).

This Board Policy and the Administrative Procedure have been developed and adopted for the purpose of complying with the School District's educational services obligations under Section 504 of the Rehabilitation Act of 1973 and its implementing regulations, and it is not designed or intended, nor should it be construed, to grant broader rights or remedies. This Board Policy and Administrative Procedure do not, and should not be construed to, create rights or remedies enforceable in contract or by any law other than Section 504 and its implementing regulations.

The School District's administration may issue interpretative memoranda and adopt directives and procedures to implement this Section 504 of the Rehabilitation Act of 1973, Board Policy, and Administrative Procedure.

The Director of Student Services is designated as the School District's Section 504 Educational Services Coordinator. As such, the Director of Student Services is responsible for coordinating the implementation of the School District's obligations under Section 504 of the Rehabilitation Act of 1973, its implementing regulations, Board Policy, and the Administrative Procedure. A student or parent/guardian, who believes that the School District has violated its obligation under Section 504 of the Rehabilitation Act of 1973 or its implementing regulations, Board Policy, or the Administrative Procedure, may file a written complaint with the School District's Section 504 Coordinator within ten (10) calendar days of the alleged violation. The Coordinator will meet with the person who filed the complaint and conduct a reasonable investigation of the facts and circumstances surrounding the complaint. If the Coordinator determines that a violation has not occurred, the Coordinator shall, in writing, so advise the person who filed the complaint and the School District's Superintendent.

If the Coordinator determines that a violation has occurred, he/she shall put his/her determination in writing, propose a fair resolution of the complaint and deliver the determination to the person who filed the complaint and the School District Superintendent. The person who filed the complaint on the School District may appeal the Coordinator's determination to the

Superintendent by so notifying the Superintendent in writing within ten (10) calendar days of the Coordinator's determination. The Superintendent may conduct additional investigation of the facts and circumstances surrounding the complaint. The Superintendent shall affirm or reverse the Coordinator's decision and, if warranted, implement the Coordinator's proposed resolution or a modification thereof. The Superintendent's decision shall be final.

A person is not required to use the procedure outlined above and may instead file a complaint directly with the U.S. Department of Education Office for Civil Rights. ~~600 Superior Avenue East, Suite 750, OH 44114-2611~~

ADMINISTRATIVE PROCEDURE

JAB

STUDENTS NONDISCRIMINATION ON THE BASIS OF HANDICAP ~~DISABILITY~~—SECTION 504

~~JUNE 6, 2016~~
December 15, 2025

The person who filed the complaint on the School District may appeal the Coordinator's determination to the Superintendent by so notifying the Superintendent in writing within ten (10) calendar days of the Coordinator's determination. The Superintendent may conduct additional investigation of the facts and circumstances surrounding the complaint. The Superintendent shall affirm or reverse the Coordinator's decision and, if warranted, implement the Coordinator's proposed resolution or a modification thereof. The Superintendent's decision shall be final.

RULE 1 — DEFINITIONS

A student is considered ~~handicapped~~ a **student with a disability** if he or she has a physical or mental impairment which substantially limits one or more major life activity, has a record of such an impairment, or is regarded as having such an impairment.

A student is considered qualified if he or she is of an age during which non-~~handicapped~~ **disabled** students are provided such services, if it is mandatory under state law to provide such services to non-~~handicapped~~ **disabled** students, or if the School District is required to provide a free appropriate public education to the student under IDEA.

RULE 2 — EDUCATION OF QUALIFIED HANDICAPPED STUDENTS WITH A DISABILITY

The School District will provide qualified ~~handicapped~~ students **with a disability** with regular and special education and related aids and services that are designed to meet their educational needs as adequately as the needs of non-~~handicapped~~ **disabled** students are met in accordance with the procedural safeguards required by law and this Procedure.

If a qualified ~~handicapped~~ student **with a disability** needs, or is believed to need, regular or special education and related aids and services, the School District will implement the evaluation procedures of Rule 3, unless otherwise mutually agreed to by the School District and parent(s)/guardian or adult student, before taking any action with respect to the initial placement of the student in a regular or special education program and any subsequent significant change in placement.

Qualified ~~handicapped~~ students **with a disability** will be integrated with non-~~handicapped~~ **disabled** students in academic, nonacademic, and extracurricular settings to the maximum extent appropriate to their needs. To this end, qualified ~~handicapped~~ students **with a disability** will be placed in the regular education environment unless such placement cannot be achieved satisfactorily with the use of supplementary aids and services. When qualified ~~handicapped~~ students **with a disability** are placed in segregated facilities, those facilities and the services and activities provided therein will be comparable to those provided in the regular education environment.

RULE 3 — EVALUATION PROCEDURES

(a) Initiation — Parent(s)/guardian, School District staff, adult students, and other appropriate persons may make a referral to the School District for initiation of the procedures set forth below. Upon referral, and prior to the initiation of the procedures set forth below, the School District shall receive written permission from the parent(s)/guardian or adult student to conduct an evaluation.

(b) Evaluation — The School District will appoint persons to a 504 Committee, which Committee will include at least one person knowledgeable about the student, to evaluate the student and/or to review and consider available diagnostic, medical, and other pertinent evaluative information submitted by the parent(s)/guardian, adult student, and/or submitted by the School District's staff and the School District's designated nonemployee evaluators.

The School District will invite the parent(s)/guardian or adult student to be participants of the 504 Committee and shall inform them by advance written notice of the dates and times of Committee meetings.

The 504 Committee, in evaluating the student, will draw upon information from a variety of sources including, but not limited to, parent(s)/guardian or adult student input and recommendations, aptitude and achievement tests, teacher recommendations, physical condition, social or cultural background, and adaptive behavior. The 504 Committee and School District appointed evaluators, including nonemployee evaluators, may administer tests and other evaluation materials to determine the nature and extent of the student's need for regular education with related aids or services or special education and related aids or services, provided: (1) the tests and other evaluation materials have been validated for the specific purpose for which they are used and are administered by trained personnel in conformance with the instructions provided by their producer; (2) the tests and other evaluation materials include those tailored to assess specific areas of educational need and not merely those which are designed to provide a single, general intelligence quotient; and (3) the tests are selected and administered so as best to ensure that, when a test is administered to a student with impaired sensory, manual, or speaking skills, the test results accurately reflect the student's aptitude or achievement level, or whatever other factor the test purports to measure, rather than reflecting the student's impaired sensory, manual, or speaking skills (except where those skills are the factors that the test purports to measure).

(c) Eligibility and Placement — The 504 Committee will, considering all evaluative information and other input, determine whether the student is qualified and ~~handicapped~~ **disabled** within the meaning of federal law, Board Policy, and this Administrative Procedure. If the Committee determines that the student is qualified and ~~handicapped~~ **disabled**, it will next consider whether regular education with the use of supplementary aids and services or special education and related aids or services are necessary to meet the student's educational needs as adequately as the needs of non-~~handicapped~~ **disabled** students and, if so, the nature and extent to which regular education with the use of supplementary aids and services or special education and

related aids or services are necessary. The Committee will bear in mind that qualified handicapped students with a disability must be placed in the regular education environment unless it is demonstrated that such a placement cannot be achieved satisfactorily with the use of supplementary aids and services.

RULE 4 — REEVALUATION

A 504 Committee shall periodically reevaluate qualified handicapped students with a disability in accordance with federal law. Such a reevaluation shall occur before any significant change in the student's placement.

RULE 5 — NOTICE OF PROCEDURAL SAFEGUARDS

The parent/guardian or adult student will be provided written notice of their rights under Board Policy and this Administrative Procedure. The procedural rights include: the right to file a complaint with the School District appointed 504 Coordinator over an alleged violation of Section 504, Board Policy, and this Procedure; the right to have an evaluation by the 504 Committee; the right to be informed of any proposed action, or refusal to take action, relating to the 504 Committee's eligibility and/or placement decisions; the right to examine all relevant school records; the right to receive all information in the parent(s)/guardian and student's native language and primary mode of communication; the right to a reevaluation periodically or before any significant change in placement; the right to an impartial hearing if there is disagreement with the 504 Committee's proposed action or refusal to take action regarding the eligibility and/or placement of the student; the right to be represented by counsel in the impartial hearing process; the right to appeal the hearing officer's decision.

RULE 6 — DUE PROCESS HEARING

A parent(s)/guardian or adult student wishing to contest the 504 Committee's determinations may request an impartial hearing at which the parent(s)/guardian or adult student and their counsel may participate. The parent(s)/guardian or adult student's request for an impartial hearing shall be in writing and shall specifically identify the areas of disagreement with the 504 Committee's report, as well as the reasons for the disagreement. A request for an impartial hearing must be made within twenty-five (25) calendar days following the date on which the report was issued.

The Superintendent of Schools, or his/her designee, upon receipt of a complete and timely request for an impartial hearing, shall appoint an impartial hearing officer to take evidence and to issue a decision regarding the 504 Committee's action, or refusal to take action, regarding the eligibility and/or placement of the student. The impartial hearing officer shall be chosen by the District from those individuals who are identified as hearing officers by the Michigan Department of Education's Office of Administrative Law, who are willing to serve under this policy and who are not District employees. The impartial hearing officer shall not have any authority to consider any other matter without the parties' consent.

RULE 7 — HEARING RIGHTS AND RESPONSIBILITIES

At an impartial hearing conducted pursuant to federal law, Board Policy, and this Administrative Procedure, the School District and parent(s)/guardian or adult student have the following rights: (1) to be represented by counsel or other individuals knowledgeable with respect to the problems of handicapped students with disabilities; (2) to present evidence and confront and cross-examine witnesses; (3) to prohibit the introduction of evidence or the direct testimony of witnesses who have not been disclosed to that party not less than five (5) calendar days before the hearing; (4) to obtain a written or electronic verbatim recording of the hearing at the expense of the party requesting it (this provision may be waived by the School District based upon financial hardship).

The parent/guardians or adult student may have the hearing private or open to the public and the student who is the subject of the hearing may be present.

The hearing officer shall issue a written decision. The hearing officer's decision shall be promptly mailed or delivered to the School District and the parent(s)/guardian or adult student.

The parent(s)/guardian or School District may appeal the hearing officer's decision to a court of competent jurisdiction within the time and in the manner permitted by law.

~~to obtain a written or electronic verbatim recording of the hearing at the expense of the party requesting it (this provision may be waived by the School District based upon financial hardship)~~

~~The parent/guardians or adult student may have the hearing private or open to the public and the student who is the subject of the hearing may be present.~~

~~The hearing officer shall issue a written decision. The hearing officer's decision shall be promptly mailed or delivered to the School District and the parent(s)/guardian or adult student.~~

~~The parent(s)/guardian or School District may appeal the hearing officer's decision to a court of competent jurisdiction within the time and in the manner permitted by law~~