

**LIVONIA PUBLIC SCHOOLS
BOARD OF EDUCATION**

**Regular Meeting
January 30, 2023 - 6:30 PM
Board Room
15125 Farmington Road
Livonia, Michigan 48154**

AGENDA

- I. ROLL CALL: Madeline Acosta, Tammy Bonifield, Karen Bradford, Colleen Burton, Dan Centers, Liz Jarvis, Mark Johnson**
- II. PLEDGE OF ALLEGIANCE**
- III. COMMUNICATIONS**
 - A. District Update from the Superintendent**
 - B. Board Recognition Month 3**
 - C. Written Communications**
 - D. Response to Prior Audience Communications**
 - E. Audience Communications (limited to 15 minutes, with remainder taking place prior to HEARING FROM BOARD MEMBERS)**
- IV. CONSENT AGENDA--Items marked with an "*" will be considered in one motion. These routine items have been individually reviewed by Board committees and were unanimously recommended for placing on this consent agenda. Any member of the Board may remove items from the consent agenda prior to voting. 6**
- V. DISPOSITION OF MINUTES**
 - A. *Minutes of the Regular Meeting of December 12, 2022 7**
- VI. BUSINESS MATTERS**
 - A. Approval to Purchase Furniture for LCTC & Robotics - 2021 Bond 23**
 - B. Approval of IT Bid Results for LCTC & Robotics - 2021 Bond 134**
 - C. Approval of IT Bid Results for 2023 Renovations - 2021 Bond 140**
 - D. Approval of Bid Results for Security Cameras 145**
 - E. Approval of Bid Results for Early Childhood Center - 2021 Bond 151**
 - F. Approval of Bid Results for Franklin Tennis Courts 166**
 - G. Approval of TMP Contract Amendment 174**
 - H. Approval to Purchase Playground Equipment for Webster RISE Program 178**
 - I. Approval to Purchase Furniture for Stevenson Community Room 181**
- VII. INSTRUCTION MATTERS**
 - A. Recommend Expulsion for One Secondary Student 192**
- VIII. PERSONNEL MATTERS**
 - A. Teachers for Approval 1 193**

B. Teachers for Tenure	195
C. Leave of Absence	196
D. Resignation	197
E. Retirements	198
IX. HEARING FROM BOARD MEMBERS	
A. First Reading of Board Bylaw BBABA - Duties of the President	201
B. First Reading of Board Policy JI - Pledge of Allegiance	203
C. Second Reading of Board Policies:	205
IDDA - Special Education Programs	
IDDD - Programs for the Academically Talented	
II - Systemwide Assessment Program	
IIA - Testing Programs (Removal of Policy)	
IIC - Use and Dissemination of Assessment Results	
D. Approval for Board Members to Participate in MASB's Virtual Winter Institute and Take MASB Classes	214
E. Hearing from Board Members	
X. ADJOURNMENT	

33500 Van Born Road
Wayne, Michigan 48184-2497
www.resa.net

Daveda J. Colbert, Ph.D., Superintendent
James S. Beri, Board of Education President

January 6, 2023

All Wayne County School District Board of Education Members,

RE: School Board Recognition Resolution

The month of January provides us with an opportunity to celebrate the great work that is being done by school boards both in our county and throughout the State of Michigan. As board of education members, you continue to represent the citizens in your individual communities to ensure that your school district is providing quality educational opportunities for each and every child. In Wayne County, the commitment of over 200 school board members is reflected daily throughout the 33 school districts that educate the 265,000 students who attend public schools throughout the county.

At the December meeting of the Wayne RESA Board of Education, our Board approved the attached "Local School District Board of Education Recognition Resolution." This resolution represents the continued appreciation for your efforts from the Wayne RESA Board of Education members and provides a public acknowledgement of your dedication to public school education in Wayne County.

It is a small token, but represents the very strong feelings we hold about the important contributions you make to your community and the students you serve.

Thank you for your continued leadership and please be assured that your efforts are noticed, appreciated, and impactful!

Sincerely,

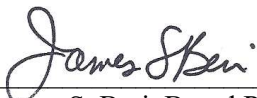

James S. Beri, Board President

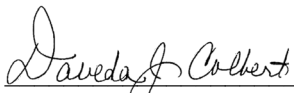

Daveda J. Colbert, Superintendent

cc: District Superintendents

**Wayne County Regional Educational Service Agency
Board of Education**

**Local School District Board of Education
Recognition Resolution**

January 2023

WHEREAS, the Boards of Education of the 33 constituent school districts of Wayne County promote quality education for each and every child attending their schools; and

WHEREAS, these committed public servants demonstrate dedication to their civic duty and voluntarily contribute countless hours of service on behalf of the students of Wayne County and their communities; and

WHEREAS, Wayne County School Boards are strong advocates for the needs of students in their communities and with policy makers in Lansing and Washington; and

WHEREAS, Wayne County School Boards are committed to ensuring healthy and safe, engaging learning environments that lead to academic success; and

WHEREAS, Wayne County School Boards understand the importance of a quality education for its students, and recognize this is the most important factor in the success of our communities, state and country; and

WHEREAS, local control continues to play a vital role in the success of public education; and

WHEREAS, especially leading through and now recovering from the effects of the pandemic, where it was confirmed how important education is to all components of our society; and

WHEREAS, School Boards have been and continue to be under immense duress and pressure to deliver improved outcomes and results now, to ensure that each and every student recovers from the interruptions of learning that took place during that time, thus deserve special recognition for their service; and

WHEREAS, the State of Michigan, and the State Board of Education have declared January 2023 as School Board Recognition Month.

NOW, THEREFORE BE IT RESOLVED, that the Wayne County Regional Educational Service Agency Board of Education in the spirit of the School Board Recognition Month, recognizes, celebrates and commends the dedication, contributions and leadership of the Wayne County School Boards of Education.

Presented and Adopted, December 14, 2022



James Beri, President

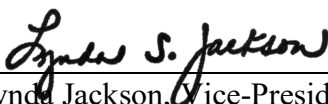

Lynda Jackson, Vice-President



Mary Blackmon, Treasurer



James Petrie, Secretary

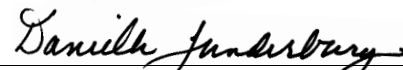

Danielle Funderburg, Trustee

STATE OF MICHIGAN



CERTIFICATE OF PROCLAMATION

ON BEHALF OF THE PEOPLE OF MICHIGAN,
I, Gretchen Whitmer, governor of Michigan, do hereby proclaim

January 2023

as

SCHOOL BOARD RECOGNITION MONTH

WHEREAS, Michigan is home to nearly 600 locally elected local school boards that work to enrich the lives of Michigan's students through education and directly influencing instruction in Michigan's public schools, and,

WHEREAS, local school board members are exceptional public servants who have dedicated and committed themselves to this duty by governing school districts, listening to parent voices, and advancing student achievement and well-being in the schools and communities they serve, and,

WHEREAS, during this month, we join with the Michigan Association of School Boards, Michigan Department of Education, local school districts and community organizations to recognize and raise awareness of the countless efforts and contributions of local school boards and school board members throughout Michigan, and,

NOW, THEREFORE, I, Gretchen Whitmer, governor of Michigan, do hereby proclaim January 2023 as School Board Recognition Month in Michigan

A handwritten signature in cursive script that reads "Gretchen Whitmer".

Gretchen Whitmer
Governor

**LIVONIA PUBLIC SCHOOLS
BOARD OF EDUCATION MEETING
January 30, 2023**

TOPIC: Consent Agenda

RECOMMENDATION:

Move that the Board of Education of the Livonia Public Schools School District approve the following consent agenda items, as recommended by the superintendent:

V.A. Minutes of the Regular Meeting of December 12, 2022

RATIONALE:

The agenda for the Board of Education meeting has certain items designated and identified by an asterisk *. These items, identified in advance with the concurrence of all Board members present, will be acted upon in a single motion.

BUDGETARY INFORMATION:

None

RESOURCE PERSONNEL:

Andrea L. Oquist, Superintendent

EXHIBITS:

Attached

Off/Supt/jw

**MINUTES
BOARD OF EDUCATION
Livonia Public Schools
Regular Meeting
December 12, 2022**

President Burton convened the meeting at 6:31 p.m.

Members Present Acosta, Bonifield, Bradford, Burton, Centers, Jarvis, Johnson

Members Absent None

Consumers Energy - Check Presentation for Energy Savings Stacy Jenkins, Administrator of Communications, and Mr. Nathan Leindecker, Energy Advisor at Consumers Energy, shared information regarding the \$237,634.72 rebate LPS received from Consumers Energy. District staff applied for the rebate and it was approved based on the increased energy efficiency achieved in LPS buildings following the replacement of roofs and boilers.

Stevenson High School State Champ Swimmer It was moved by Mr. Johnson and supported by Mrs. Acosta that the Board of Education of the Livonia Public Schools School District adopt a resolution recognizing Stevenson High School swimmer McKenzie Siroky for capturing the MHSAA Girls Division 1 Swimming State Championship title.

RESOLUTION

WHEREAS, the Trustees of the Livonia Public Schools School District Board of Education are desirous of publicly recognizing the outstanding accomplishments of students who distinguish themselves during the pursuit of their public education in the school district; and

WHEREAS, McKenzie Siroky, a senior at Stevenson High School, has distinguished herself by achieving the 2022-2023 Michigan High School Athletic Association Division 1 Girls Swim & Dive State Champion title in the 100-yard Breaststroke for the third consecutive year; and

WHEREAS, McKenzie has achieved this honor with a Stevenson High School and state record-setting time of 1:00.27 seconds; and

WHEREAS, this adds to the outstanding accomplishments McKenzie has achieved during the 2022-2023 season, including setting a new school record in the 200-yard Medley Relay, 200-yard Free Relay, and the 50-yard Freestyle; a new pool record in the 50-yard Freestyle; and a new school and state record in the 100-yard Breaststroke, in addition to being designated as an All American Swimmer in the 100-yard Breaststroke and 200-yard Medley Relay and an All State Swimmer in the 50-yard Freestyle, 200-yard Medley Relay, 200 yard Free Relay and the 100-yard Breaststroke.

NOW, THEREFORE, BE IT RESOLVED, that the Trustees of the Board of Education do hereby commend and congratulate McKenzie Siroky for her outstanding accomplishments in athletics and wish her well in her future endeavors as she applies the discipline and perseverance needed to excel in sports to all areas of her life.

Ayes: Acosta, Bonifield, Bradford, Burton, Centers, Jarvis, Johnson
Nays: None

**District Update
from the
Superintendent**

Superintendent Oquist presented highlights of recent activities taking place across the District, as well as upcoming events.

**Written
Communications**

None

**Response to Prior
Audience
Communications**

None

**Audience
Communications**

None

Consent Agenda

It was moved by Mrs. Bradford and supported by Mrs. Bonifield that the Board of Education of the Livonia Public Schools School District approve the following consent agenda items, as recommended by the superintendent:

- V.A. Minutes of the Regular Meeting of November 28, 2022
- V.B. Minutes of the Special Meeting of November 28, 2022
- V.C. Minutes of the Closed Session of November 28, 2022
- VI.A. Approval to Purchase Copy Paper
Contract Paper Group - \$84,400
- VI.G. Approval of Resolution for Summer Tax Collection
One half school property taxes collected in summer from Cities of Livonia and Westland. Annual tax collection fee assessed by Livonia is \$462,761.59; annual tax collection fee assessed by Westland is \$0.

Ayes: Acosta, Bonifield, Bradford, Burton, Centers, Jarvis, Johnson
Nays: None

**Approval of Bid
Results for
Summer 2023
Roof
Replacement**

It was moved by Mr. Centers and supported by Mrs. Bradford that the Board of Education of the Livonia Public Schools School District approve the recommendation of the Owner's Representative, Plante Moran Cresa, to award the contract for roofing replacements at Kennedy Elementary and Stevenson High School to Lutz Roofing, Lake Orion, Michigan, in the amount of \$3,570,000 plus 6% contingency in the amount of \$214,200 for a total approved project amount of \$3,784,200 and authorize the Superintendent or her designee to negotiate and execute final contracts.

Ayes: Acosta, Bonifield, Bradford, Burton, Centers, Jarvis, Johnson
Nays: None

**Approval to
Purchase Art
Tables**

It was moved by Mrs. Bonifield and supported by Mrs. Jarvis that the Board of Education of the Livonia Public Schools School District approve the purchase of art tables from Smith System, Carrollton, Texas for a total purchase price of \$90,245.21.

Ayes: Acosta, Bonifield, Bradford, Burton, Centers, Jarvis, Johnson
Nays: None

**Approval to
Purchase
Maintenance
Vehicle**

It was moved by Mrs. Acosta and supported by Mr. Johnson that the Board of Education of the Livonia Public Schools School District approve the purchase of one truck from Gorno Ford, Woodhaven, Michigan, for a total cost of \$51,698.

Ayes: Acosta, Bonifield, Bradford, Burton, Centers, Jarvis, Johnson
Nays: None

**Approval to
Purchase School
Buses – 2021
Bond**

It was moved by Mrs. Jarvis and supported by Mr. Centers that the Board of Education of the Livonia Public Schools School District approve the purchase of school buses from Holland Bus Company, Holland, Michigan for a cost of \$744,195.

Ayes: Acosta, Bonifield, Bradford, Burton, Centers, Jarvis, Johnson
Nays: None

**Approval of
Dickinson
Abatement
Contingency**

It was moved by Mr. Johnson and supported by Mrs. Jarvis that the Board of Education of the Livonia Public Schools School District approve increased contingency funding for abatement at Dickinson Center in the amount of \$37,000.

Ayes: Acosta, Bonifield, Bradford, Burton, Centers, Jarvis, Johnson
Nays: None

**Approval of 2022-
23 First Budget
Amendment**

It was moved by Mrs. Bradford and supported by Mr. Centers that the Board of Education of the Livonia Public Schools approve the amended budgets for the 2022-2023 school year: General Fund, Funded Projects Fund, Special Education Fund, Debt Retirement Fund, 2021 Bond Fund, Sinking Fund, Capital Projects Fund, Food Services Fund, Health and Welfare Fund, Scholarship Fund and School Activities Fund.



Livonia Public Schools

2022-23 First Amended General Fund & District Budgets

December 2022

**RESOLUTION FOR BUDGET ADOPTION
BY THE BOARD OF EDUCATION
LIVONIA PUBLIC SCHOOLS**

RESOLVED, that the general appropriation for Livonia Public Schools for revenues for the fiscal year 2022-23
General Fund be amended as follows:

	2021-22 Actual	2022-23 Proposed	2022-23 First Amended
Revenue			
Local	42,269,985	38,682,095	40,579,544
State	114,081,654	120,261,959	119,604,261
Federal	52,309	43,169	51,729
Other Financing Sources	2,592,400	2,592,400	2,727,064
Total Revenue	\$ 158,996,348	\$ 161,579,623	\$ 162,962,598
Fiscal Year Beginning Fund Balance	\$ 33,099,290	\$ 32,594,107	\$ 33,691,834
Revenue Plus Beginning Fund Balance (Total Available to Appropriate)	\$ 192,095,638	\$ 194,173,730	\$ 196,654,432

RESOLUTION FOR BUDGET ADOPTION BY THE BOARD OF EDUCATION LIVONIA PUBLIC SCHOOLS

RESOLVED, that the general appropriation for Livonia Public Schools for expenditures for the fiscal year 2022-23 General Fund be amended as follows:

	2021-22 Actual	2022-23 Proposed	2022-23 First Amended
Expenditures			
Instruction			
Basic Programs	79,079,405	81,018,034	83,115,932
Added Needs	14,552,624	15,333,034	15,799,236
Total Instruction	\$ 93,632,029	\$ 96,351,068	\$ 98,915,168
Support Services			
Pupil Support	9,125,223	8,416,620	8,518,792
Instructional Staff Support	7,645,941	8,486,114	7,747,679
General Administration	833,949	935,277	962,433
School Administration	10,602,534	11,170,929	11,345,033
Business Services	1,942,334	2,111,495	2,186,285
Operations and Maintenance	17,771,457	19,020,875	19,178,860
Transportation	7,381,870	8,191,485	8,063,753
Other Central Support	4,753,356	4,948,930	5,237,446
Athletics	2,412,255	2,440,789	2,440,789
Total Support Services	\$ 62,468,920	\$ 65,722,514	\$ 65,681,070
Community Services	\$ 1,390,396	\$ 2,620,489	\$ 1,784,009
Other Financing Uses	\$ 912,459	\$ -	\$ 900,000
Total Expenditures	\$ 158,403,804	\$ 164,694,071	\$ 167,280,247
Ending Fund Balance = Total Available to Appropriate less Total Expenditures	\$ 33,691,834	\$ 29,479,659	\$ 29,374,185
Fund Balance as a Percentage of Total Expenditures	21.3%	17.9%	17.6%

FUNDED PROJECTS FUND

* The Funded Projects Fund is reported in the General Fund on the Comprehensive Annual Financial Report submitted to the State.

	2021-22 Actual	2022-23 Proposed	2022-23 First Amended
Beginning Fund Balance	\$ -		\$ (877,400)
Revenues			
Local	55,368	101,735	195,763
State	6,446,287	6,571,954	10,293,308
Federal	15,965,187	26,389,559	27,544,069
Total Revenue	\$ 22,466,841	\$ 33,063,248	\$ 38,033,140
Expenditures			
Instructional	14,058,187	17,472,621	17,562,993
Support	7,436,373	13,669,151	17,313,683
Community Services	1,514,004	1,572,072	1,667,112
Other Financing Uses	335,677	349,404	611,953
Total Expenditures	\$ 23,344,241	\$ 33,063,248	\$ 37,155,741
Ending Fund Balance	\$ (877,400)	\$ -	\$ -
Revenue Detail			
Local Sources			
Dunning Foundation	12,000	-	-
LPS Foundation	30,842	21,508	63,097
Miscellaneous Local Sources	950	-	28,939
Wayne RESA	11,576	80,227	103,727
Total Local Sources	\$ 55,368	\$ 101,735	\$ 195,763
State Sources			
Section 11r(4) ESSER Per Pupil Equalization	300,420	-	-
Section 23b (2)d Innovative Summer Programs	154,179	154,180	-
Section 31a At Risk	3,705,914	4,240,933	4,675,772
Section 31aa Per-Pupil Mental Health Grant	-	-	1,424,464
Section 31n(6) Mental Health			180,000
Section 32d Great School Readiness	614,334	675,120	770,826
Section 35a Early Literacy	333,531	333,531	318,062
Section 41 Bilingual Education	146,153	146,433	158,587
Section 54d Early On	117,500	117,500	283,750
Section 61 Vocational Education	696,171	526,172	639,184
Section 97 Per-Pupil Student Safety	-	-	1,424,464
Section 97d Critical Incident Mapping	-	-	105,408
Section 99h FIRST Robotics	19,905	19,905	
Section 107 Adult Education	358,180	358,180	312,791
Total State Sources	\$ 6,446,287	\$ 6,571,954	\$ 10,293,308
Federal Sources			
CACFP Emergency Operations	965	-	
Child Care Grant	1,371,343	-	1,496,566
Emergency Connectivity	28,218	3,229,920	3,192,000
ESSER Grants	4,270,278	10,190,277	9,969,841
IDEA Grants	5,190,895	4,021,561	4,437,294
Michigan Clean Diesel	-	73,529	73,529
NSLP Equipment Assistance	31,500	31,500	-
Section 23 Grants	358,104	661,165	940,312
Section 11p Coronavirus Relief	2,283,351	-	-
Section 11t ESSER Per Pupil Equalization	-	5,538,520	5,538,520
Title I Part A	1,353,500	1,394,465	1,057,706
Title II Part A	493,194	577,940	263,776
Title III Part A English Learners	52,321	71,740	50,471
Title III Part A Immigrant Learners	28,007	29,073	19,543
Title IV, Part A SSAE	93,718	103,693	78,915
Vocational Perkins	288,472	288,472	244,089
WIOA- Adult Basic Education- Instruction	121,323	177,704	181,507
Total Federal Sources	\$ 15,965,187	\$ 26,389,559	\$ 27,544,069

SPECIAL EDUCATION FUND

	2021-22 Actual		2022-23 Proposed		2022-23 First Amended
Beginning Fund Balance	\$ 2,798,352	\$	898,352	\$	1,108,043
Revenues					
Local	10,061,177		10,340,274		13,725,609
State	6,852,962		8,490,754		7,559,006
Total Revenue	\$ 16,914,139	\$	18,831,028	\$	21,284,615
Expenditures					
Instructional	9,280,444		10,039,099		11,188,907
Support	5,824,005		6,601,929		7,228,262
Transfers to Other Funds	3,500,000		2,200,000		3,000,000
Total Expenditures	\$ 18,604,449	\$	18,841,028	\$	21,417,169
Ending Fund Balance	\$ 1,108,043	\$	888,352	\$	975,489
Expenditure Detail					
Moderate Cognitive Impairment Program	3,247,079		3,459,099		3,924,559
Visually Impaired Program	1,659,279		1,811,346		1,806,185
Skill Center Program	3,686,045		4,264,841		3,895,840
Autistic Program	6,389,392		7,105,744		8,659,182
Additional Expenditures (3%)	122,655		-		131,403
Transfer to Other Funds	3,500,000		2,200,000		3,000,000
Total Expenditures	\$ 18,604,449	\$	18,841,030	\$	21,417,169

DEBT RETIREMENT FUNDS (RESTRICTED)

	2021-22 Actual	2022-23 Proposed	2022-23 First Amended
Beginning Fund Balance	\$ 3,794,623	\$ 1,729,584	\$ 2,267,497
Revenues			
Tax Revenue	21,082,847	20,850,826	20,850,826
Interest Income	27,672	1,000	30,000
Total Revenue	\$ 21,110,519	\$ 20,851,826	\$ 20,880,826
Expenditures			
Bond Redemption	14,030,000	13,250,000	13,250,000
Bond Interest	8,605,345	8,397,994	8,397,994
Other	2,300	200,000	200,000
Total Expenditures	\$ 22,637,645	\$ 21,847,994	\$ 21,847,994
Ending Fund Balance	\$ 2,267,497	\$ 733,416	\$ 1,300,329

Expenditure Detail

Bond Redemption

2013 Bond Series 1	900,000	1,175,000	1,175,000
2013 Bond Series 2	1,450,000	1,850,000	1,850,000
2014 Refunding Bond	7,810,000	4,185,000	4,185,000
2020 Refunding Bond	-	1,245,000	1,245,000
2021 Bond Series 1	3,870,000	4,795,000	4,795,000
Bond Redemption- Total	\$ 14,030,000	\$ 13,250,000	\$ 13,250,000

Bond Interest

2013 Bond Series 1	161,000	125,000	125,000
2013 Bond Series 2	3,513,750	3,441,250	3,441,250
2014 Refunding Bond	764,750	374,250	374,250
2020 Refunding Bond	1,888,195	1,888,194	1,888,194
2021 Bond Series 1	2,277,650	2,569,300	2,569,300
Bond Interest- Total	\$ 8,605,345	\$ 8,397,994	\$ 8,397,994

2021 BOND (RESTRICTED)

	2021-22		2022-23		2022-23
	Actual		Proposed		First Amended
Beginning Fund Balance	\$ 77,547,490	\$	43,597,490	\$	65,206,723
Revenues					
Other Financing Sources	-		-		-
Interest Income	(384,277)		50,000		500,000
Total Revenue	\$ (384,277)	\$	50,000	\$	500,000
Expenditures					
Facility Improvements	11,601,599		40,000,000		60,000,000
Other	354,891		2,000,000		4,000,000
	\$ 11,956,490	\$	42,000,000	\$	64,000,000
Ending Fund Balance	\$ 65,206,723	\$	1,647,490	\$	1,706,723

SINKING FUND (RESTRICTED)

	2021-22 Actual		2022-23 Proposed		2022-23 First Amended
BEGINNING FUND BALANCE	\$ 4,436,012	\$	1,254,415	\$	3,925,250
REVENUES					
Local	7,706,045		7,937,726		7,937,726
Other Financing Sources	-		-		95,446
Total Revenue	\$ 7,706,045	\$	7,937,726	\$	8,033,172
EXPENDITURES					
Facility Improvements	8,186,807		8,000,000		10,000,000
Other	30,000		600,000		600,000
	\$ 8,216,807	\$	8,600,000	\$	10,600,000
ENDING FUND BALANCE	\$ 3,925,250	\$	592,141	\$	1,358,422

CAPITAL PROJECTS FUND (RESTRICTED)

	2021-22 Actual		2022-23 Proposed		2022-23 First Amended
BEGINNING FUND BALANCE	\$ 3,654,690	\$	3,402,097	\$	3,121,370
REVENUES					
Proceeds from Sale of Property	49,060		50,000		50,000
Transfer from Other Funds	2,395,436		500,000		1,520,000
Total Revenue	\$ 2,444,496	\$	550,000	\$	1,570,000
EXPENDITURES					
Facility Improvements	2,881,201		-		1,000,000
Other	96,615		3,000,000		-
Total Expenditures	\$ 2,977,816	\$	3,000,000	\$	1,000,000
ENDING FUND BALANCE	\$ 3,121,370	\$	952,097	\$	3,691,370

FOOD SERVICE FUND

(RESTRICTED)

		2021-22		2022-23		2022-23
		Actual		Proposed		First Amended
Beginning Fund Balance	\$	39,831	\$	2,262,821	\$	1,872,790
Revenues						
Local Sales		250,604		202,000		250,000
State Reimbursement		133,716		186,451		100,874
Federal Reimbursement		5,998,639		1,980,000		1,980,000
Other Financing Sources		-		-		-
Total Revenue	\$	6,382,959	\$	2,368,451	\$	2,330,874
Expenditures						
Support Services		4,310,000		3,250,000		3,500,000
Transfers to Other Funds		240,000		200,000		240,000
Total Expenditures	\$	4,550,000	\$	3,450,000	\$	3,740,000
Ending Fund Balance	\$	1,872,790	\$	1,181,272	\$	463,664

HEALTH & WELFARE FUND

		2021-22		2022-23		2022-23
		Actual		Proposed		First Amended
Beginning Fund Balance	\$	1,251,258	\$	1,157,241	\$	593,800
Revenues						
Employee Contributions		2,785,504		2,552,703		2,950,000
Transfer From Other Funds		18,096,252		19,495,198		20,006,555
Total Revenue	\$	20,881,756	\$	22,047,902	\$	22,956,555
Expenditures						
Premiums/Claims/Fees	\$	21,539,214	\$	22,112,309	\$	23,050,355
Ending Fund Balance	\$	593,800	\$	1,092,834	\$	500,000

SCHOLARSHIP FUND (RESTRICTED)

		2021-22 Actual		2022-23 Proposed		2022-23 First Amended
Beginning Fund Balance	\$	37,233	\$	39,314	\$	44,359
Revenues						
Local- Donations	\$	18,081	\$	6,000	\$	6,000
Expenditures						
Scholarships	\$	10,955	\$	12,000	\$	12,000
Ending Fund Balance	\$	44,359	\$	33,314	\$	38,359

SCHOOL ACTIVITIES FUND (RESTRICTED)

		2021-22 Actual		2022-23 Proposed		2022-23 First Amended
Beginning Fund Balance	\$	1,479,721	\$	1,479,721	\$	1,609,323
Revenue- School Deposits	\$	2,080,471	\$	2,000,000	\$	2,000,000
Expenditures- School Activities	\$	1,950,869	\$	2,000,000	\$	2,000,000
Ending Fund Balance	\$	1,609,323	\$	1,479,721	\$	1,609,323

Ayes: Acosta, Bonifield, Bradford, Burton, Centers, Jarvis, Johnson
Nays: None

Approval of Resolution to Authorize the Issuance and Sale of Bonds

It was moved by Mr. Centers and supported by Mrs. Jarvis that the Board of Education of the Livonia Public Schools School District approve the attached resolution authorizing the issuance of bonds, delegation of the sale of bonds, and other matters relating thereto, including the authorization of the Superintendent to execute necessary documents and agreements.

Ayes: Acosta, Bonifield, Bradford, Burton, Centers, Jarvis, Johnson
Nays: None

Teachers for Approval

It was moved by Mrs. Bonifield and supported by Mrs. Acosta that the Board of Education of the Livonia Public Schools School District accept the recommendation of the superintendent and offer employment for the 2022-23 school year to the following teachers:

Gearns, Katherine	1.0 Resource Room Teacher	Webster
Hutko, Alexandra	1.0 Resource Room Teacher	Kennedy
Vipond, Christina	1.0 Speech/Language Therapist	Frost

Ayes: Acosta, Bonifield, Bradford, Burton, Centers, Jarvis, Johnson
Nays: None

Resignation

The Board was informed of the resignation of:

Danielle Daniels	11/30/22
------------------	----------

Retirement

It was moved by Mrs. Acosta and supported by Mrs. Bradford that the Board of Education of the Livonia Public Schools School District adopt a resolution of appreciation for:

Kathryn Lamont, who will retire from the District on December 31, 2022, and has devoted 17.3 years of dedicated, loyal, and outstanding service to the Livonia Public Schools as a paraprofessional in the Transportation Department

Ayes: Acosta, Bonifield, Bradford, Burton, Centers, Jarvis, Johnson
Nays: None

First Reading of Board Policies

Proposed changes to the policies below were reviewed by the Board and will be on the agenda of the next Regular Board meeting for a second reading and potential approval.

BOARD POLICY	IDDA
INSTRUCTIONAL PROGRAM	MARCH 16, 2015
SPECIAL EDUCATION PROGRAMS	

The Board of Education provides special programs and services to meet the needs of its students with special needs. These programs and services will be coordinated by the Department of Student Services, which interprets and operates these services according

~~to law.~~

The School District will provide eligible students with Individualized Education Plans (IEP) programming and services to meet their needs. These programs and services will be coordinated by the Department of Student Services and its staff. The District will abide by all applicable laws, including State and Federal laws such as Michigan Administrative Rules for Special Education (MARSE) and Individuals with Disability Education Act (IDEA).

BOARD POLICY **IDDD**
INSTRUCTIONAL PROGRAM **JUNE 20, 1988**
PROGRAMS FOR THE GIFTED ACADEMICALLY TALENTED

~~The Board of Education shall encourage the staff to seek out those organizational arrangements, teaching methods and other instructional provisions for providing the appropriate learning and development of all academically talented and otherwise gifted students. To this end, pilot programs may be established, and studies and research conducted to ascertain appropriate curricular and instructional means for accomplishing the above objective.~~

The School District will provide academically talented students access to learning opportunities both in general education classrooms and in magnet programs, to meet their needs. These programs and services will be coordinated by the directors of elementary and secondary education with the support of the Academic Services Department.

Staff may conduct studies and research to ascertain appropriate curricular and instructional opportunities and programming for academically talented students.

BOARD POLICY **II**
INSTRUCTIONAL PROGRAM **DATE**
SYSTEMWIDE ASSESSMENT STANDARDIZED TESTING PROGRAM

The purpose of the systemwide assessment program is to plan appropriate instructional activities for each student in addition to providing the School District and each school essential information on the growth and achievement of our learners.

The School District will select and administer a series of aptitude, diagnostic and standardized achievement assessments, which provide information related to a student's learning potential as well as longitudinal achievement data on individual learners and cohorts of students in the District. Other appropriate assessments may be used for diagnostic purposes.

The School District shall assess learning based on the current standards and curriculum being used in classrooms across the District. This includes, but is not limited to, school improvement assessments, common course and grade level assessments, and unit tests. These assessments, along with standardized assessments, provide a broader picture of a student's abilities and attainment of standards. In addition, surveys and student focus groups provide a "picture" of students' thoughts, feelings and attitudes.

BOARD POLICY **IIA**
INSTRUCTIONAL PROGRAM **JUNE 20, 1988**
TESTING PROGRAMS

~~The Board of Education expects the staff to select and administer a series of mental capacity tests and standardized achievement tests, particularly in the areas of the so-called basic skills and study skills, as one source of data indicating the nature of the students' potential and of their longitudinal achievement as they progress through the schools. Other appropriate tests may be used on an optional basis for diagnostic~~

purposes.

Although it is the general attitude of this Board that reasonable limits should be placed on the administering of tests to students, it is permissible to administer selected so-called external tests to those students desiring to take the same for college entrance, scholarships, academic competition, and college placement.

The Board of Education encourages the staff to examine continually the values which reflect the objectives of the School System, the needs of students, and the circumstances in society which indicate the necessity for new or different educational experiences. As a result of such study and reexamination, the staff is further encouraged to seek better means for assessing learning in such areas as the cognitive abilities including inductive thinking, the process of inquiry, critical thinking, and the process of problem-solving. Also, it is expected that assessment means should be found or devised through which data may be gathered regarding learning in the so-called "affective domain," including such factors as feelings, attitudes, and appreciations.

LEGAL REF.:

BOARD POLICY **IIC**
INSTRUCTIONAL PROGRAM **JUNE 20, 1988**
USE AND DISSEMINATION OF TEST ASSESSMENT RESULTS

~~All parents and students 18 and over have full access to all educational records or data relating to the student. Student records will not be released to a third party without prior written consent of the parents or the student if over 18, with exceptions made for other school officials and governmental education agencies or as otherwise provided by law.~~

The District will provide all parents/guardians and students who are over 18, full access to personal educational data. Student records will not be released to a third party without prior written consent of the parent/guardian or student (if over 18), with the exceptions made for Livonia Public Schools staff, governmental educational agencies or other persons, as provided by law.

Adjournment

President Burton adjourned the meeting at 7:59 p.m.

Off/Supt/jw

**LIVONIA PUBLIC SCHOOLS
BOARD OF EDUCATION MEETING
January 30, 2023**

TOPIC: Approval to Purchase Furniture for LCTC & Robotics - 2021 Bond

RECOMMENDATION:

Move that the Board of Education of the Livonia Public Schools School District accept the recommendation from the Owner's Representative, Plante Moran Cresa, to approve the purchase and installation of furniture for LCTC and Robotics from NBS Commercial Interiors, Troy, Michigan; Interior Office Source, Milford, Michigan; KI Direct, Green Bay, Wisconsin; DEW-EL, Holland, Michigan; Interior Environments, Novi, Michigan; and Wenger, Owantonna, Minnesota for a total amount not to exceed \$285,258, which includes contingency.

RATIONALE:

This purchase is for the LCTC and Robotics programs. The new furniture will provide necessary seating and work areas for the renovated spaces and the new addition to the LCTC/Robotics building. Some examples of furniture items are tables, chairs, storage units, work benches, booths, and soft seating.

BUDGETARY INFORMATION:

2021 Bond

RESOURCE PERSONNEL:

Phillip Francis, Assistant Superintendent of District Services

EXHIBITS:

Attached

PF/ko

January 16, 2023

Mr. Phillip Francis
Asst. Superintendent of District Services
Livonia Public Schools
15125 Farmington Road
Livonia, MI 48154

RE: 2021 Bond Program
LMC Furniture Purchase Recommendation
LCTC/Robotics Addition & Renovations

Dear Mr. Francis:

This letter transmits an update from Plante Moran Cresa (PMC) as it relates to the assignment to assist and advise Livonia Public Schools (LPS) in its purchase of furniture for the Project listed above. This update represents the mutual efforts of PMC, TMP Architects, and LPS administration and staff (the Team).

Coinciding with the new LCTC/Robotics building addition and renovations, the Team has conducted multiple meetings and site visits over the course of the past few months focused on the selection of furniture to best serve the new spaces.

The Team recommends awarding the following contractors to supply and install furniture in an amount not-to-exceed **\$285,258.00** as further detailed below and within TMP's recommendation documents.

NBS Commercial Interiors	\$135,796.40
Interior Office Source	\$47,897.50
KI Direct	\$28,613.12
DEW-EL	\$3,836.14
Interior Environments	\$39,373.53
Wenger	\$16,157.59
<hr/>	
Sub-Total	\$271,674.28
Contingency (5%)	\$13,583.72
<hr/>	
Total	\$285,258.00

For the Vendors, the pricing for this work will be detailed in Purchase Order Agreements, pending final review and approval of terms by district legal counsel.

The Team is available at the Board's convenience to answer any questions regarding this recommendation. Please direct all questions through me via email at brian.weber@plantemoran.com.

Sincerely,

PLANTE MORAN CRESA



Brian Weber
Vice President

Enclosures: TMP Recommendation Letter
 Vendor Proposals
 Product Information & Layout



January 18, 2023

Mr. Phillip Francis
 Livonia Public Schools
 15125 Farmington Rd.
 Livonia, MI 48154

Re: Furnishing Recommendation
 Livonia Career Technical Center and Robotics Addition
 TMP Project No. 21036A

Dear Mr. Francis,

Quotations were received for the furniture for the Livonia Career Technical Center and Robotics Addition by multiple furniture contractors. Each furniture contractor has referenced the cooperative bid contract utilized to determine pricing within their quotes. The table below identifies each Category's associated costs, furniture manufacturer / contractor, and contract utilized. TMP recommends the procurement of furnishing packages as follows:

<u>MANUFACTURER CATEGORY</u>	<u>CONTRACT</u>	<u>AMOUNT</u>
<u>NBS Commercial Interiors</u>		
Category A: ERG International	TIPS	\$61,129.03
Category B: Steelcase	E&I	\$10,795.01
Category C: AMQ	E&I	\$29,410.32
Category D: Smith System	E&I	\$29,563.29
Category L: Safco	Omnia	\$4,898.75
<u>NBS COMMERCIAL INTERIORS TOTAL AWARD</u>		<u>\$135,796.40</u>
<u>Interior Office Source</u>		
Category F: WB Manufacturing	PEPPM	\$39,819.50
Category H: Fleetwood	NCPA	\$8,078.00
<u>INTERIOR OFFICE SOURCE TOTAL AWARD</u>		<u>\$47,897.50</u>
<u>KI Direct</u>		
Category E: KI	Sourcwell	\$28,613.12
<u>KI DIRECT TOTAL AWARD</u>		<u>\$28,613.12</u>
<u>DEW-EL</u>		
Category G: Media Technologies	NCPA	\$3,836.14
<u>DEW-EL TOTAL AWARD</u>		<u>\$3,836.14</u>
Category I: Not Used	----	-----

Livonia Public Schools
Furnishing Package
TMP Project No.: 21036A
Page No. 2

Interior Environments

Category J: Allsteel	Omnia	\$26,029.12
Category K: Watson	Omnia	\$13,344.41

<u>INTERIOR ENVIRONMENTS TOTAL AWARD</u>	\$39,373.53
---	--------------------

Wenger

Category M: Wenger	Omnia	\$16,157.59
---------------------------	-------	-------------

<u>WENGER TOTAL AWARD</u>	\$16,157.59
----------------------------------	--------------------

PACKAGE TOTAL AMOUNT: \$271,674.28

Sincerely,

TMP ARCHITECTURE, INC.



Lauren Bush, Interior Designer
LEB/leb
Enclosure (Specifications, Quotes, and Furnishing Package Presentation)

CATEGORY A:
ERG INTERNATIONAL

Livonia CTC/Robotics Furnishings
 Livonia Public School District
 TMP Project No.: 21036A
 1/12/2023

CATEGORY A: ERG International

Item	Total Qty	Manufacturer	Model No.	Location Qty	Description
<i>*(to include freight, delivery and installation)</i>					
A1	6	ERG International	8306		Raven Collection Size: 44" W Straight Unit (4 Legs) Overall Height: 33" High Fully Upholstered Back Flat Ganging Device for Soft Seating (GD2)
		<i>* Image for reference, not exact product.</i>			
					Finishes: Upholstery: CF Stinson Fuse 2.0 FSE 238 (Slate) Leg Color: Brushed Aluminum
				6	Location: Commons A101

Livonia CTC/Robotics Furnishings
 Livonia Public School District
 TMP Project No.: 21036A
 1/12/2023

CATEGORY A: ERG International

Item	Total Qty	Manufacturer	Model No.	Location Qty	Description		
A2	2	ERG International	8302		Raven Collection Size: 22" W Straight Unit (4 Legs) Overall Height: 33" High Fully Upholstered Back Flat Ganging Device for Soft Seating (GD2)		
		* Image for reference, not exact product.					
							
					Finishes: Upholstery: CF Stinson Fuse 2.0 FSE 238 (Slate) Leg Color: Brushed Aluminum	30	
				2	Location: Commons A101		

Livonia CTC/Robotics Furnishings
 Livonia Public School District
 TMP Project No.: 21036A
 1/12/2023

CATEGORY A: ERG International

Item	Total Qty	Manufacturer	Model No.	Location Qty	Description	
A3	3	ERG International	8386		Raven Collection Size: Corner Unit - Square Seat (4 legs) Overall Height: 33" High Fully Upholstered Back Flat Ganging Device for Soft Seating (GD2) Finishes: Upholstery: CF Stinson Fuse 2.0 FSE 238 (Slate) Leg Color: Brushed Aluminum Location: Commons A101	
		* Image for reference, not exact product.				
					3	

Livonia CTC/Robotics Furnishings
 Livonia Public School District
 TMP Project No.: 21036A
 1/12/2023

CATEGORY A: ERG International

Item	Total Qty	Manufacturer	Model No.	Location Qty	Description
------	-----------	--------------	-----------	--------------	-------------

A4	10	ERG International	CAP105		Capri Collection Almost Rectangle Top Rectangle Metal Base
		<i>* Image for reference, not exact product.</i>			



Finishes:
 High Pressure Laminate Top: Wilsonart,
 Manitoba Maple, 7911-60
 Base Color: Brushed Aluminum

Location:
 6 Commons A101
 4 Large Group Room B112

Livonia CTC/Robotics Furnishings
 Livonia Public School District
 TMP Project No.: 21036A
 1/12/2023

CATEGORY A: ERG International

Item	Total Qty	Manufacturer	Model No.	Location Qty	Description
A5	1	ERG International	DUN24D		Duncan Occasional Round Size: 24" dia., 18" table height 4 Legs
					<i>* Image for reference, not exact product.</i>
					
					Finishes: High Pressure Laminate Top: Wilsonart, Manitoba Maple, 7911-60 Leg Color: Brushed Aluminum
				1	Location Commons A101

Livonia CTC/Robotics Furnishings
 Livonia Public School District
 TMP Project No.: 21036A
 1/12/2023

CATEGORY A: ERG International

Item	Total Qty	Manufacturer	Model No.	Location Qty	Description
A6	3	ERG International	8380		Raven Collection 48" W Back-to-Back Banquette Size: 48" Wide x 51.5" Deep x 33" High 6 Legs Two Fabric Option Finishes: Seat Upholstery: CF Stinson Fuse 2.0, FSE 223 (Peacock) Back Upholstery: Designtex Big Dot, 3525-803 (Smoke) Leg Color: Brushed Aluminum
		* Image for reference, not exact product.			
				3	Location Commons A110



34

Livonia CTC/Robotics Furnishings
 Livonia Public School District
 TMP Project No.: 21036A
 1/12/2023

CATEGORY A: ERG International

Item	Total Qty	Manufacturer	Model No.	Location Qty	Description
A7	1	ERG International	8372		Raven Collection 48" W Straight Banquette Size: 48" Wide x 27" Deep x 33" High 4 Legs Two Fabric Option Finishes: Seat Upholstery: CF Stinson Fuse 2.0, FSE 223 (Peacock) Back Upholstery: Designtex Big Dot, 3525-803 (Smoke) Leg Color: Brushed Aluminum
				1	Location Commons A110



** Image for reference, not exact product.*

35

Livonia CTC/Robotics Furnishings
 Livonia Public School District
 TMP Project No.: 21036A
 1/12/2023

CATEGORY A: ERG International

Item	Total Qty	Manufacturer	Model No.	Location Qty	Description
A8	4	ERG International	MON42D		Monaco Collection Monaco Café Round Table Size: 42" dia., 29" Table Height 22" Base Spread Finishes: High Pressure Laminate Top: Wilsonart, Manitoba Maple, 7911-60 Leg Color: Brushed Aluminum
			<i>* Image for reference, not exact product.</i>		
				4	Location Commons A110



Livonia CTC/Robotics Furnishings
 Livonia Public School District
 TMP Project No.: 21036A
 1/12/2023

CATEGORY A: ERG International

Item	Total Qty	Manufacturer	Model No.	Location Qty	Description
A9	4	ERG International	MON3048		<p>Monaco Collection Monaco Café Rectangle Table Size: 30" x 48" x 29" Table Height 2-17" Base Spread</p> <p>Finishes: High Pressure Laminate Top: Wilsonart, Manitoba Maple, 7911-60 Leg Color: Brushed Aluminum</p> <p>Location Commons A110</p>
		* Image for reference, not exact product.		4	



Livonia CTC/Robotics Furnishings
 Livonia Public School District
 TMP Project No.: 21036A
 1/12/2023

CATEGORY A: ERG International

Item	Total Qty	Manufacturer	Model No.	Location Qty	Description
A10	12	ERG International	DAK48D/CAS3/FLIPX		<p>Dakota Collection Dakota Café Round Table Size: 48" Dia. X 29" High Table Base Spread: 38" - X With Casters, Black (CASD) Incline Nesting Legs (CIN) With Flip Top Mechanism</p> <p><i>* Image for reference, not exact product.</i></p> <div style="display: flex; justify-content: space-around; align-items: center;">  </div> <p>Finishes: High Pressure Laminate Top: Wilsonart, Manitoba Maple, 7911-60 Leg Color: Brushed Aluminum Caster Color: Black</p> <p>Location 12 Large Group Room B112</p>

CATEGORY B:

STEELCASE

Livonia CTC/Robotics Furnishings
 Livonia Public School District
 TMP Project No.: 21036A
 1/12/2023

CATEGORY B: Steelcase

Item	Total Qty	Manufacturer	Model No.	Location Qty	Description
------	-----------	--------------	-----------	--------------	-------------

**(to include freight, delivery and installation)*

B1	2	Steelcase	TS4TLP40		Steelcase Campfire Big Table with Grommets Size: 48" D x 96" W x 40" H with Modesty Panel Dual Power, TS4TPWRUSB
----	---	-----------	----------	--	---

** Image for reference, not exact product.*



Finishes:
 High Pressure Laminate: Winter on Maple 2511
 Modesty Panel: Winter on Maple 2511
 Power: Arctic White, 7241

40

Location:
 2 Commons A101

Livonia CTC/Robotics Furnishings
 Livonia Public School District
 TMP Project No.: 21036A
 1/12/2023

CATEGORY B: Steelcase

Item	Total Qty	Manufacturer	Model No.	Location Qty	Description
B2	4	Steelcase	TS31401H		<p>Jenny Lounge, Armless Fully upholstered lounge chair with tablet arm With Glides With Tablet Arm with 180 degree Swivel with High Pressure Laminate Top</p> <p>Finishes: Single Upholstery Fabric: CF Stinson, Fuse 2.0 FSE 241, Charcoal Tablet Arm: High-Pressure Laminate Winter on Maple 2511 Legs: Brushed Aluminum Legs</p> <p>Location 4 Commons A101</p>

** Image for reference, not exact product.*



CATEGORY C:

AMQ

Livonia CTC/Robotics Furnishings
 Livonia Public School District
 TMP Project No.: 21036A
 1/12/2023

CATEGORY C: AMQ

Item	Total Qty	Manufacturer	Model No.	Location Qty	Description
------	-----------	--------------	-----------	--------------	-------------

**(to include freight, delivery and installation)*

C1	76	AMQ	BXBYARMLESS		Bixby Armless Stacking and Nesting Chair With Soft Casters
----	----	-----	-------------	--	---

** Image for reference, not exact product.*



Finishes:

Frame Color: Platinum

Plastic Seat Color: Platinum PC3

Plastic Backrest: Platinum PC3

43

Locations:

4 Conference Room A102

72 Large Group Room B112

Livonia CTC/Robotics Furnishings
 Livonia Public School District
 TMP Project No.: 21036A
 1/12/2023

CATEGORY C: AMQ

Item	Total Qty	Manufacturer	Model No.	Location Qty	Description
C2	92	AMQ	BXBYARMLESS		Bixby Armless Stacking and Nesting Chair With Soft Casters
					<i>* Image for reference, not exact product.</i>
					Finishes: Frame Color: Platinum Plastic Seat Color: Wasabi PC6 Plastic Backrest: Wasabi PC6
					Locations: 36 Flex Classroom A107 36 Flex Classroom A108 4 Robotics Field A116 16 Commons A110



CATEGORY D:
SMITH SYSTEM

Livonia CTC/Robotics Furnishings
 Livonia Public School District
 TMP Project No.: 21036A
 1/12/2023

CATEGORY D: Smith System

Item	Total Qty	Manufacturer	Model No.	Location Qty	Description
------	-----------	--------------	-----------	--------------	-------------

*(to include freight, delivery and installation)

D1 72 Smith System 1265

* Image for reference, not exact product.



Planner Huddle - 6 Student
 Size: 18" Deep x 30" Wide x 22'-32" High
 Edge Type: 1 1/4in Top with 3mm Edge Band
 with casters

Finishes:

High Pressure Laminate Top: Classic Linen 4943-38

Edge Finish: Champagne

Frame Finish: Platinum

Locations:

36 Flex Classroom A107

36 Flex Classroom A108

46

Livonia CTC/Robotics Furnishings
 Livonia Public School District
 TMP Project No.: 21036A
 1/12/2023

CATEGORY D: Smith System

Item	Total Qty	Manufacturer	Model No.	Location Qty	Description
D2	2	Smith System	NL2560CLNPLTE		Elemental Adjustable Nest and Fold Table Size: 24" Deep x 60" Wide x 29"-40" High Edge Type: 1 1/4in Top with 3mm Edge Band with casters
					<i>* Image for reference, not exact product.</i>
					
					Finishes: High Pressure Laminate Top: Classic Linen 4943-38 Edge Finish: Champagne Frame Finish: Platinum Caster Finish: Platinum - PLT
				2	Locations: Robotics Field A116

Livonia CTC/Robotics Furnishings
 Livonia Public School District
 TMP Project No.: 21036A
 1/12/2023

CATEGORY D: Smith System

Item	Total Qty	Manufacturer	Model No.	Location Qty	Description
D3	1	Smith System	EL3060EG		Elemental Rectangle Table Size: 30" Deep x 60" Wide x 30" High Edge Type: 1 1/4in Top with 3mm Edge Band
					<i>* Image for reference, not exact product.</i>
					
				1	Finishes: High Pressure Laminate Top: Classic Linen 4943-38 Edge Finish: Champagne Frame Finish: Platinum Locations: Conference Room A102

CATEGORY E:

KI

Livonia CTC/Robotics Furnishings
 Livonia Public School District
 TMP Project No.: 21036A
 1/12/2023

CATEGORY E: KI

Item	Total Qty	Manufacturer	Model No.	Location Qty	Description
------	-----------	--------------	-----------	--------------	-------------

**(to include freight, delivery and installation)*

E1 6 KI DN4100H30FRPSKXGFT

Doni Café Stools
 Four-Leg Armless Café Stool
 30" High
 Glide: Felt Glides (GFT)

** Image for reference, not exact product.*



Finishes:
 Solid Color, Polypropylene: PSK Sky Blue
 Frame Color: SX Starlight Silver

50

Location
 6 Commons A101

Livonia CTC/Robotics Furnishings
 Livonia Public School District
 TMP Project No.: 21036A
 1/12/2023

CATEGORY E: KI

Item	Total Qty	Manufacturer	Model No.	Location Qty	Description
E2	12	KI	DN4100H30FRPZLSXGSL		Doni Café Stools Four-Leg Armless Café Stool 30" High Glide: Steel Glides (GSL)
					<i>* Image for reference, not exact product.</i>
					Finishes: Solid Color, Polypropylene: PZL Zesty Lime Frame Color: SX Starlight Silver
				12	Location Commons A101



Livonia CTC/Robotics Furnishings
 Livonia Public School District
 TMP Project No.: 21036A
 1/12/2023

CATEGORY E: KI

Item	Total Qty	Manufacturer	Model No.	Location Qty	Description
------	-----------	--------------	-----------	--------------	-------------

E3	3	KI	RKT301841OP/36T		Ruckus Tote Storage Tall 2-Column Unit, Open with (10) 3" and (4) 6" Totes Totes included - translucent with no lid With Casters
----	---	----	-----------------	--	--

** Image for reference, not exact product.*



Finishes:
 Shell Color: Sky Blue, SK

52

Locations:
 3 Storage A105

Livonia CTC/Robotics Furnishings
 Livonia Public School District
 TMP Project No.: 21036A
 1/12/2023

CATEGORY E: KI

Item	Total Qty	Manufacturer	Model No.	Location Qty	Description
E4	2	KI	RKT301841DR/36T		<p>Ruckus, Tote Storage, Tall, 2 Column unit with locking doors Size: 30" Wide x 18" Deep x 40 3/4" High Totes included - translucent with no lid (10) 3" and (4) 6" Totes With Casters All Lockable Storage Keyed Alike</p> <p>Finishes: Shell Color: Sky Blue, SK Beveled Pull - Satin Chrome</p> <p>Locations: 2 Robotics Field A116</p>

** Image for reference, not exact product.*



Livonia CTC/Robotics Furnishings
 Livonia Public School District
 TMP Project No.: 21036A
 1/12/2023

CATEGORY E: KI

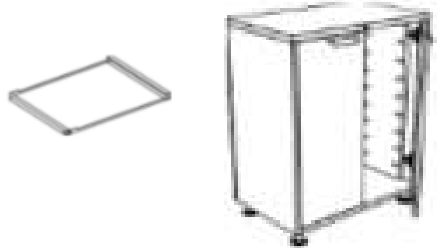
Item	Total Qty	Manufacturer	Model No.	Location Qty	Description
E5	3	KI	RKT301841DR/36T RKATSSHELF		Ruckus, Tote Storage, Tall, 2 Column unit with locking doors Size: 30" Wide x 18" Deep x 40 3/4" High Empty - No totes included With Casters Ruckus Tote Storage Removable Steel Shelf with Rail Set All Lockable Storage Keyed Alike
			<i>* Image for reference, not exact product.</i>		
					
					Finishes: Shell Color: Sky Blue, SK Beveled Pull - Satin Chrome Removable Shelf Color: Sky Blue, SK
					Locations: 3 Robotics Field A116

Livonia CTC/Robotics Furnishings
 Livonia Public School District
 TMP Project No.: 21036A
 1/12/2023

CATEGORY E: KI

Item	Total Qty	Manufacturer	Model No.	Location Qty	Description
E6	2	KI	RKT301841DR/36T		<p>Ruckus, Tote Storage, Tall, 2 Column unit with locking doors Size: 30" Wide x 18" Deep x 40 3/4" High Empty - No totes included With Casters All Lockable Storage Keyed Alike</p> <p>Finishes: Shell Color: Sky Blue, SK Beveled Pull - Satin Chrome</p> <p>Locations: 2 Robotics Field A116</p>

** Image for reference, not exact product.*



Livonia CTC/Robotics Furnishings
 Livonia Public School District
 TMP Project No.: 21036A
 1/12/2023

CATEGORY E: KI

Item	Total Qty	Manufacturer	Model No.	Location Qty	Description
E7	3	KI	RKT301828OP/36T		<p>Ruckus Tote Storage, Short 2-Column Unit, Open with (8) 3" and (2) 6" Totes Size: 30" Wide x 18" Deep x 27 3/4" High (8) 3" totes and (2) 6" totes With Casters</p> <p>Finishes: Shell Color: Sky Blue, SK</p> <p>Locations: 3 Robotics Studio A124</p>
		<p><i>* Image for reference, not exact product.</i></p> 			

Livonia CTC/Robotics Furnishings
 Livonia Public School District
 TMP Project No.: 21036A
 1/12/2023

CATEGORY E: KI

Item	Total Qty	Manufacturer	Model No.	Location Qty	Description
------	-----------	--------------	-----------	--------------	-------------

E8	3	KI	RKT301828OP/3T		Ruckus Tote Storage, Short 2-Column Unit, Open with (12) 3" Totes Size: 30" Wide x 18" Deep x 27 3/4" High With Casters
----	---	----	----------------	--	--

** Image for reference, not exact product.*



Finishes:
 Shell Color: Sky Blue, SK

57

Locations:
 3 Robotics Studio A117

Livonia CTC/Robotics Furnishings
 Livonia Public School District
 TMP Project No.: 21036A
 1/12/2023

CATEGORY E: KI

Item	Total Qty	Manufacturer	Model No.	Location Qty	Description
E9	4	KI	RKT301828OP/3T		Ruckus Tote Storage, Short 2-Column Unit, Open with (6) 6" Totes Size: 30" Wide x 18" Deep x 27 3/4" High With Casters
					<i>* Image for reference, not exact product.</i>
					
					Finishes: Shell Color: Sky Blue, SK
				4	Locations: Robotics Studio A117

Livonia CTC/Robotics Furnishings
 Livonia Public School District
 TMP Project No.: 21036A
 1/12/2023

CATEGORY E: KI

Page No. 10 of 10

Item	Total Qty	Manufacturer	Model No.	Location Qty	Description
E10	50	KI	618WA		600 Series Industrial Stool Adjustable Height, 19"-27" High Self-leveling glides
					<i>* Image for reference, not exact product.</i>
					
					Finishes: Seat: Wood Frame Color: Warm Grey, WG
					Locations: 20 Robotics Studio A117 6 Robotics Studio A118 24 Robotics Studio A124

CATEGORY F:
WB MANUFACTURING

Livonia CTC/Robotics Furnishings
 Livonia Public School District
 TMP Project No.: 21036A
 1/12/2023

CATEGORY F: WB Manufacturing

Item	Total Qty	Manufacturer	Model No.	Location Qty	Description
------	-----------	--------------	-----------	--------------	-------------

**(to include freight, delivery and installation)*

F1 10 WB Manufacturing TOR9107

** Image for reference, not exact product.*



TORO Table with True Maple Top
 Fully Welded 16-gauge 1" x 2" heavy duty steel apron
 Size: 48" x 48"
 Adjustable Legs: 1.5" square, steel tube -
 22" - 38" overall height with nylon glides

Finishes:
 Top: Maple Butcher Block 1.75" Thick Top
 Legs: Smooth Silver (G4)
 Frame: Smooth Silver (G4)

Location:
 4 Robotics Studio A117
 6 Robotics Studio A124

Livonia CTC/Robotics Furnishings
 Livonia Public School District
 TMP Project No.: 21036A
 1/12/2023

CATEGORY F: WB Manufacturing

Item	Total Qty	Manufacturer	Model No.	Location Qty	Description
F2	7	WB Manufacturing	TOR9069		<p>TORO Table with True Maple Top Fully Welded 16-gauge 1" x 2" heavy duty steel apron Size: 24" x 48" Adjustable Legs: 1.5" square, steel tube - 22" - 38" overall height with nylon glides With Half Depth Shelf</p> <p>Finishes: Top: Maple Butcher Block 1.75" Thick Top Legs: Smooth Silver (G4) Frame: Smooth Silver (G4)</p> <p>Location: 4 Robotics Studio A117 3 Robotics Studio A124</p>
					<p><i>* Image for reference, not exact product.</i></p> 

Livonia CTC/Robotics Furnishings
 Livonia Public School District
 TMP Project No.: 21036A
 1/12/2023

CATEGORY F: WB Manufacturing

Item	Total Qty	Manufacturer	Model No.	Location Qty	Description
F3	2	WB Manufacturing	TOR9070		<p>TORO Table with True Maple Top Fully Welded 16-gauge 1" x 2" heavy duty steel apron Size: 24" x 54" Adjustable Legs: 1.5" square, steel tube - 22" - 38" overall height with nylon glides</p> <p><i>* Image for reference, not exact product.</i></p>  <p>Finishes: Top: Maple Butcher Block 1.75" Thick Top Legs: Smooth Silver (G4) Frame: Smooth Silver (G4)</p> <p>Location: 2 Robotics Studio A117</p>

Livonia CTC/Robotics Furnishings
 Livonia Public School District
 TMP Project No.: 21036A
 1/12/2023

CATEGORY F: WB Manufacturing

Item	Total Qty	Manufacturer	Model No.	Location Qty	Description
F4	4	WB Manufacturing	TOR9092		<p>TORO Table with True Maple Top Fully Welded 16-gauge 1" x 2" heavy duty steel apron Size: 36" x 60" Adjustable Legs: 1.5" square, steel tube - 22" - 38" overall height with nylon glides With Half Depth Shelf</p> <p>Finishes: Top: Maple Butcher Block 1.75" Thick Top Legs: Smooth Silver (G4) Frame: Smooth Silver (G4)</p> <p>Location: 4 Robotics Studio A118</p>

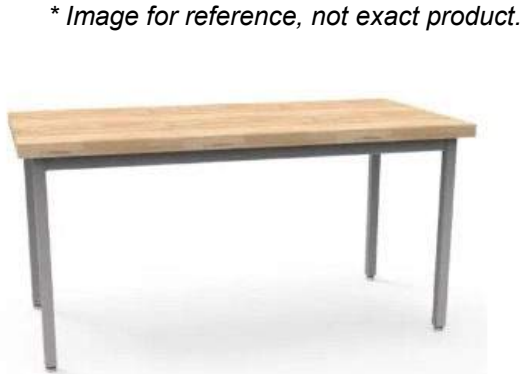

CATEGORY G:
MEDIA TECHNOLOGIES

Livonia CTC/Robotics Furnishings
 Livonia Public School District
 TMP Project No.: 21036A
 1/12/2023

CATEGORY G: Media Technologies

Item	Total Qty	Manufacturer	Model No.	Location Qty	Description
------	-----------	--------------	-----------	--------------	-------------

**(to include freight, delivery and installation)*

G1	2	Media Tech	CBLOX-17-17		Media Technologies Blox Seating Cylinder 17" Dia x 17" H High Density Foam Core
----	---	------------	-------------	--	---

** Image for reference, not exact product.*



Finishes:
 Upholstery: Designtex Rise, Penny 3809-701

Location:
 2 Commons A101

Livonia CTC/Robotics Furnishings
 Livonia Public School District
 TMP Project No.: 21036A
 1/12/2023

CATEGORY G: Media Technologies

Item	Total Qty	Manufacturer	Model No.	Location Qty	Description
G2	2	Media Tech	CBLOX-17-17		Media Technologies Blox Seating Cylinder 17" Dia x 17" H High Density Foam Core
					<i>* Image for reference, not exact product.</i>
					Finishes: Upholstery: Designtex Rise, Grass 3809-502
				2	Location: Commons A101



Livonia CTC/Robotics Furnishings
 Livonia Public School District
 TMP Project No.: 21036A
 1/12/2023

CATEGORY G: Media Technologies

Item	Total Qty	Manufacturer	Model No.	Location Qty	Description
G3	1	Media Tech	CBLOX-17-17		Media Technologies Blox Seating Cylinder 17" Dia x 17" H High Density Foam Core
					<i>* Image for reference, not exact product.</i>
					Finishes: Upholstery: Designtex Rise, Pool 3809-403
				1	Location: Commons A101



Livonia CTC/Robotics Furnishings
 Livonia Public School District
 TMP Project No.: 21036A
 1/12/2023

CATEGORY G: Media Technologies

Item	Total Qty	Manufacturer	Model No.	Location Qty	Description
G4	2	Media Tech	CBLOX-17-17		Media Technologies Blox Seating Cylinder 17" Dia x 17" H High Density Foam Core
					<i>* Image for reference, not exact product.</i>
					Finishes: Upholstery: CF Stinson, La Scalina LAS 14 Flow
				2	Location: Commons A101



CATEGORY H:

FLEETWOOD

Livonia CTC/Robotics Furnishings
 Livonia Public School District
 TMP Project No.: 21036A
 1/12/2023

CATEGORY H: Fleetwood Furniture

Item	Total Qty	Manufacturer	Model No.	Location Qty	Description
------	-----------	--------------	-----------	--------------	-------------

**(to include freight, delivery and installation)*

H1	3	Fleetwood	25RS640		Crank Height Adjustable Table Size: 60" Wide x 42" Depth Adjustable height with crank 2" diameter levelers - all legs 11.5" height adjustable legs Tubular base Metal Modesty Panel
----	---	-----------	---------	--	---

** Image for reference, not exact product.*



3	Robotics Studio A118
---	----------------------

Finishes:
 Top: Solid Maple Block
 Base: Silver Paint

Locations:
 Robotics Studio A118

CATEGORY I:

NOT USED

CATEGORY J:

ALLSTEEL

Livonia CTC/Robotics Furnishings
 Livonia Public School District
 TMP Project No.: 21036A
 1/12/2023

CATEGORY J: Allsteel

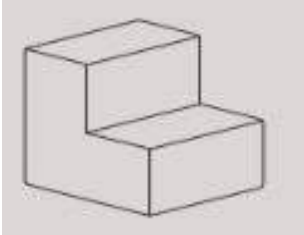
Item	Total Qty	Manufacturer	Model No.	Location Qty	Description
<i>*(to include freight, delivery and installation)</i>					
J1	5	Allsteel	S922S2		Allsteel Rise Rise 2-Tier Seating Dimensions: 34" H x 36" W x 40" D Non-Powered Finishes: Upholstery: CF Stinson Fuse 2.0, FSE 238 (Slate)
		<i>* Image for reference, not exact product.</i>			
					
				5	Large Group Room B112

Livonia CTC/Robotics Furnishings
 Livonia Public School District
 TMP Project No.: 21036A
 1/12/2023

CATEGORY J: Allsteel

Item	Total Qty	Manufacturer	Model No.	Location Qty	Description
J2	3	Allsteel	S922S2		Allsteel Rise Rise 2-Tier Seating Dimensions: 34" H x 36" W x 40" D Non-Powered Finishes: Upholstery: CF Stinson Fuse 2.0, FSE 227 (Chive)
				3	Location: Large Group Room B112

** Image for reference, not exact product.*

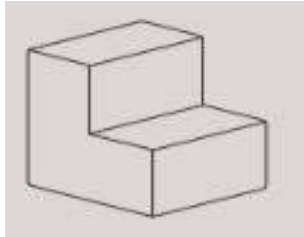

Livonia CTC/Robotics Furnishings
 Livonia Public School District
 TMP Project No.: 21036A
 1/12/2023

CATEGORY J: Allsteel

Item	Total Qty	Manufacturer	Model No.	Location Qty	Description
J3	1	Allsteel	S922S3		Allsteel Rise Rise 3-Tier Seating Dimensions: 34" H x 36" W x 40" D Non-Powered Finishes: Upholstery: CF Stinson Fuse 2.0, FSE 227 (Chive)
				1	Large Group Room B112

** Image for reference, not exact product.*

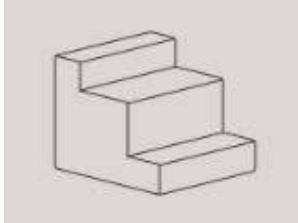

Livonia CTC/Robotics Furnishings
 Livonia Public School District
 TMP Project No.: 21036A
 1/12/2023

CATEGORY J: Allsteel

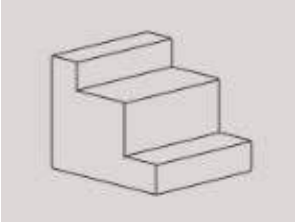
Item	Total Qty	Manufacturer	Model No.	Location Qty	Description	
J4	1	Allsteel	S922S3		Allsteel Rise Rise 3-Tier Seating Dimensions: 34" H x 36" W x 40" D Non-Powered Finishes: Upholstery: CF Stinson Fuse 2.0, FSE 223 Peacock) Location: 2 Large Group Room B112	
		* Image for reference, not exact product.				
						

Livonia CTC/Robotics Furnishings
 Livonia Public School District
 TMP Project No.: 21036A
 1/12/2023

CATEGORY J: Allsteel

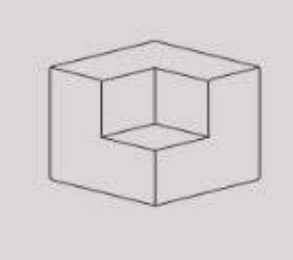
Item	Total Qty	Manufacturer	Model No.	Location Qty	Description
J5	2	Allsteel	S922S21C		Allsteel Rise Rise 2-Tier Inside Corner Dimensions: 34" H x 40" W x 40" D
					<i>* Image for reference, not exact product.</i>
					
					Finishes: Upholstery: CF Stinson Fuse 2.0, FSE 223 Peacock)
				2	Location: Large Group Room B112

CATEGORY K:

WATSON

Livonia CTC/Robotics Furnishings
 Livonia Public School District
 TMP Project No.: 21036A
 1/12/2023

CATEGORY K: Watson

Item	Total Qty	Manufacturer	Model No.	Location Qty	Description
------	-----------	--------------	-----------	--------------	-------------

*(to include freight, delivery and installation)

K1	11	Watson Furniture	WEM204660		Etch Mobile Markerboard Size: 46" Wide x 20" Deep x 60" High with casters and Marker Cloth
----	----	------------------	-----------	--	--

* Image for reference, not exact product.



Finishes:
 Powdercoat Finish: Sapphire, SAP

- Locations:
- 2 Commons A101
 - 6 Robotics Studio A124
 - 1 Commons A110
 - 2 Large Group Room B112

Livonia CTC/Robotics Furnishings
 Livonia Public School District
 TMP Project No.: 21036A
 1/12/2023

CATEGORY K: Watson

Item	Total Qty	Manufacturer	Model No.	Location Qty	Description
K2	11	Watson Furniture	WEMC020304		Etch Magnetic Marker Cup Accessory Size: 3" Wide x 4" High x 2" Deep
					<i>* Image for reference, not exact product.</i>
					
					Finishes: Manufacturer's Standard Finish
					Locations:
				2	Commons A101
				6	Robotics Studio A124
				1	Commons A110
				2	Large Group Room

CATEGORY L:

SAFCO

Livonia CTC/Robotics Furnishings
 Livonia Public School District
 TMP Project No.: 21036A
 1/12/2023

CATEGORY L: Safco

Item	Total Qty	Manufacturer	Model No.	Location Qty	Description
------	-----------	--------------	-----------	--------------	-------------

**(to include freight, delivery and installation)*

L1	5	Safco	6244BL		Safco Boltless Steel and Particleboard Shelving Wood Deck with 5 Shelves Size: 48" W x 24" D x 72" H
----	---	-------	--------	--	--

** Image for reference, not exact product.*



Finishes:
 Metal: Black
 Shelves: Natural Wood

Locations:
 2 Robotics Studio Storage A119
 3 Storage A105

Livonia CTC/Robotics Furnishings
 Livonia Public School District
 TMP Project No.: 21036A
 1/12/2023

CATEGORY L: Safco

Item	Total Qty	Manufacturer	Model No.	Location Qty	Description
------	-----------	--------------	-----------	--------------	-------------

L2	9	Safco	6247BL		Safco Boltless Steel and Particleboard Shelving Wood Deck with 5 Shelves Size: 36" W x 24" D x 72" H
----	---	-------	--------	--	--

** Image for reference, not exact product.*



Finishes:
 Metal: Black
 Shelves: Natural Wood

Locations:
 3 Storage A121
 3 Storage A122
 3 Storage A123

CATEGORY M:

WENGER

Livonia CTC/Robotics Furnishings
 Livonia Public School District
 TMP Project No.: 21036A
 1/12/2023

CATEGORY M: Wenger

Item	Total Qty	Manufacturer	Model No.	Location Qty	Description
------	-----------	--------------	-----------	--------------	-------------

*(to include freight, delivery and installation)

M1 1 Wenger CUSTOM

** Image for reference, not exact product.*

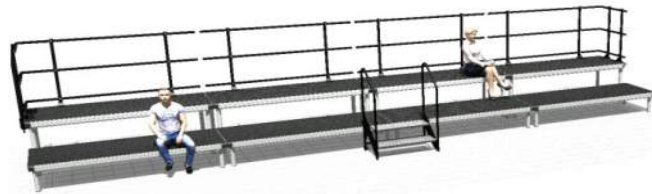

Wenger StageTek Audience Seating
 Based on Quote No. 3262777
 Overall Dimensions: 32'-0" x 6'-0"
 (8) StageTek Rectangular Deck 3'x8'
 (16) StageTek Fixed Leg 32" Elevation
 (32) StageTek Fixed Leg 16" Elevation
 (14) StageTek Connect, 2 Leg Rectangular
 (12) Leg Storage Clip, 4 pk
 (4) StageTek Standard Guardrail 8'
 (2) StageTek Standard Guardrail 3'
 (8) Leg Straps, 45", 2 pk
 (1) StageTek 2-Step Stairway 16/24" with Rail
 (3) Staging Universal Deck and Rail Cart

Finishes:
 Rectangular Desk: Cracked Ice, Black
 Metal Finish: Black

Location:
 1 Robotics Field A116



2595 Bellingham • Troy, MI 48083 • 248.823.5400 • 248.823.5401 Fax
 2211 Old Earhart Rd. Ste.190 • Ann Arbor, MI 48105 • 248.823.5400 • 248.823.5401 Fax
 3201 Pine Tree Rd. Ste. A • Lansing, MI 48911 • 517.886.0072 • 248.823.5401 Fax
 5160 Alliance Dr. • Bay City, MI 48706 • 989.895.8574 • 989.895.8545 Fax
 4 North St. Clair St. • Toledo, OH 43604 • 419.662.2040 • 248.823.5401 Fax

Quotation 357940

Quote Date 01/09/23
Customer Order
Project 222305
Customer L00002
Terms NET 10 DAYS
Expiration Date
Account Representative ANNE MARIE TREMBERTH (HCT)

yourNBS.com **Remit Payments to:** NBS, 6973 Reliable Parkway, Chicago, IL 60686

Quote To

Livonia Public Schools
 15125 FARMINGTON RD
 LIVONIA, MI, 48154-5413

Ship To

Lauren Bush
 Livonia Career Technical Center
 8985 Newburgh Rd
 Livonia, MI, 48150

Phone +1 (313) 523-9156
Fax +1 (734) 421-4870

Phone +1 (248) 338-4561

Lbush@tmp-architecture.com

Sales Location Troy

Target install dates: 7.31.23 - 8.11.23
3-4 days needed for NBS install

Following contracts utilized for pricing on this quote:

E&I Contract: STC, AMQ, Smith System

Omnia: Safco

TIPS + Add'l project discounting: ERG

School is responsible for contract membership enrollment. Changes to specifications and quantity could affect tiered contract pricing.

Pricing valid for 30 days.

Please verify finish selections prior to order placement.

If due to unforeseen circumstances the building is not ready to receive furniture, additional fees may be incurred to double handle and/or store the furniture. Circumstances include, but are not limited to construction delays and COVID-19.

Storage Free for 30 days, after which storage is charged per SF per month.

Quote includes Non-Union labor for NBS to receive, deliver and install during Normal Business Hours; any owner requested changes requiring additional delivery trip(s) will result in additional charges to be quoted separately.

Overtime Labor (evening after hours and weekends) additional.

Purchase Order and 40% Deposit is required before order placement; please reference NBS quote number on PO. Receipt of PO indicates owner approval of product as specified; upon release of order, no changes, cancellations or returns can be made.

***NOTE: DEPOSIT WAIVED FOR LPS**

Thank you!

Lead time: 14-16 weeks

TITLE OF PRODUCT TRANSFERS UPON RECEIPT BY CUSTOMER.

Description	Quantity	Unit Price	Extended Price												
Category C AMQ															
1 BXBYARMLESS - AMQ Bixby Chair Armless Cushion: No Cushion Frame Finish: Paint PC03 - Platinum Seat Shell Finish: Plastic PL03 - Platinum Back Shell Finish: Plastic PL03 - Platinum Castors or Glides: Soft Castors Accessories: No Accessory Storage Tray: No Storage Tray AMQ SOLUTI Tag For C1	76	152.04	11,555.04												
<table border="0"> <tr> <td style="text-align: right;">Qty</td> <td>Description</td> </tr> <tr> <td style="border-top: 1px solid black;"></td> <td style="border-top: 1px solid black;"></td> </tr> <tr> <td>4</td> <td>Conference Room A102</td> </tr> <tr> <td>72</td> <td>Large Group Room B112</td> </tr> </table>	Qty	Description			4	Conference Room A102	72	Large Group Room B112							
Qty	Description														
4	Conference Room A102														
72	Large Group Room B112														
2 BXBYARMLESS - AMQ Bixby Chair Armless Cushion: No Cushion Frame Finish: Paint PC03 - Platinum Seat Shell Finish: Plastic PL06 - Wasabi Back Shell Finish: Plastic PL06 - Wasabi Castors or Glides: Soft Castors Accessories: No Accessory Storage Tray: No Storage Tray AMQ SOLUTI Tag For C2	92	152.04	13,987.68												
<table border="0"> <tr> <td style="text-align: right;">Qty</td> <td>Description</td> </tr> <tr> <td style="border-top: 1px solid black;"></td> <td style="border-top: 1px solid black;"></td> </tr> <tr> <td>36</td> <td>Flex Classroom A107</td> </tr> <tr> <td>36</td> <td>Flex Classroom A108</td> </tr> <tr> <td>4</td> <td>Robotics Field A116</td> </tr> <tr> <td>16</td> <td>Commons A110</td> </tr> </table>	Qty	Description			36	Flex Classroom A107	36	Flex Classroom A108	4	Robotics Field A116	16	Commons A110			
Qty	Description														
36	Flex Classroom A107														
36	Flex Classroom A108														
4	Robotics Field A116														
16	Commons A110														
3 LOT - Non-Union, normal hours. Receive, Deliver, and Installation of Product. One phase. Elevator access, as necessary Free and clear space No Removal of Existing Product Overtime Labor, if required, would be an additional charge. Storage free for 30 days. After which storage is charged per LF per month.	1	3,867.60	3,867.60												

TITLE OF PRODUCT TRANSFERS UPON RECEIPT BY CUSTOMER.

yourNBS.com

Remit Payments to: NBS, 6973 Reliable Parkway, Chicago, IL 60686

Description	Quantity	Unit Price	Extended Price
3 ROSE MOVIN			
Sub Total			29,410.32
Total			29,410.32

Category D Smith System

4	SMPLN01265 - Planner Huddle Desk-Circle, 6-Student Worksurface Finish: SMITH SYSTEM LAMINATE 494360 - CLASSIC LINEN LAMINATE Edge Type: F - 1 1/4in Top w 3mm Edgbnd Edge Finish: Smith System Plastic CHAMPAGN - CHAMPAGNE Leg Finish: SMITH SYSTEM PAINT PLT - PLATINUM SMITH SYST Tag For D1	72	213.60	15,379.20
---	---	----	--------	-----------

Qty Description

36	Flex Classroom A107
36	Flex Classroom A108

5	SMEMTNL2460 - Elemental; Table-Nest and fold, With casters, 24D x 60W Worksurface Finish: Smith System Laminate 494360 - CLASSIC LINEN LAMINATE Edge Type: F-1 1/4in Top w 3mm Edgbnd Edge Finish: Smith System Plastic CHAMPAGN - CHAMPAGNE Leg Finish: Smith System Paint PLT - Platinum Height: EJ - Adjustable Height SMITH SYST Tag For D2	2	763.80	1,527.60
---	---	---	--------	----------

Qty Description

2	Robotics Field A116
---	---------------------

6	SMEMTEL3060 - Elemental; Table-Rectangle, 30D x 60W Worksurface Finish: Smith System Laminate 494360 - CLASSIC LINEN LAMINATE Edge Type: F-1 1/4in Top w 3mm Edgbnd Edge Finish: Smith System Plastic CHAMPAGN - CHAMPAGNE Leg Finish: Smith System Paint PLT - Platinum Height: EG - Fixed Height w/ Glide SMITH SYST Tag For D3	1	390.00	390.00
---	---	---	--------	--------

Qty Description

1	Conference Room A102
---	----------------------

TITLE OF PRODUCT TRANSFERS UPON RECEIPT BY CUSTOMER.

89

ACCEPTED BY _____ TITLE _____ DATE _____

Description	Quantity	Unit Price	Extended Price
7 17576 - 3" CASTER PK 4LK 3/8THD PU TRD SMITH SYST Tag For for use with D1 & D3 TABLE	73	61.20	4,467.60
9 FREIGHT - FREIGHT SMITH SYST	1	2,550.00	2,550.00
10 LOT - Non-Union, normal hours. Receive, Deliver, and Installation of Product. One phase. Elevator access, as necessary Free and clear space No Removal of Existing Product Overtime Labor, if required, would be an additional charge. Storage free for 30 days. After which storage is charged per LF per month. ROSE MOVIN	1	5,248.89	5,248.89

Sub Total	29,563.29
Total	29,563.29

Category L Global alternate

11 6244BL - Boltless Steel & Particle Board Shelving 48 x 24 X 72, Black 5 SHELVES SAFCO PROD Tag For L1	5	228.66	1,143.30
12 6247BL - Boltless Steel & Particle Board Shelving 36 x 24"x 72 Black 5 shelves SAFCO PROD Tag For L2	9	195.05	1,755.45
13 LOT - Non-Union, normal hours. Receive, Deliver, and Installation of Product. One phase. Elevator access, as necessary Free and clear space No Removal of Existing Product Overtime Labor, if required, would be an additional charge. Storage free for 30 days. After which storage is charged per LF per month. ROSE MOVIN	1	2,000.00	2,000.00



2595 Bellingham • Troy, MI 48083 • 248.823.5400 • 248.823.5401 Fax
 2211 Old Earhart Rd. Ste.190 • Ann Arbor, MI 48105 • 248.823.5400 • 248.823.5401 Fax
 3201 Pine Tree Rd. Ste. A • Lansing, MI 48911 • 517.886.0072 • 248.823.5401 Fax
 5160 Alliance Dr. • Bay City, MI 48706 • 989.895.8574 • 989.895.8545 Fax
 4 North St. Clair St. • Toledo, OH 43604 • 419.662.2040 • 248.823.5401 Fax

Quotation 357940
 Page 5 / 10 (cont'd)

yourNBS.com

Remit Payments to: NBS, 6973 Reliable Parkway, Chicago, IL 60686

Description	Quantity	Unit Price	Extended Price
Sub Total			4,898.75
Total			4,898.75

Category B Steelcase

14 **TS4TLP40** - Campfire; Big Table, Power cutout, 96W x 48D x 40H 2 2,627.06 5,254.12
TOP OPT: *OPT:TOP OPTION
HPL TOP: HPL TOP
TOP-SURF: TOP SURFACE
LAM HPL: *TOP-SURF:LAMINATE (HPL)
2511: WINTER ON MAPLE
CON OPT: *OPT:CONTRASTING MODESTY PNL OPTION
NOCONMOD: NO CONTRASTING MODESTY PANEL
PWR OPT: *OPT:POWER OPTIONS
1PWR1USB: RECEPTACLE 1 PWR 1 USB
GROMMET: GROMMET
TEXTPNT: *GROMMET:TEXTURED PAINT
7241: ARCTIC WHITE

STEELCASE

Tag For B1

Qty Description

2 Commons A101

15 **COM FABRIC** - CF STINSON FUSE 2.0 CHARCOAL 1 425.00 425.00
 NBS TROY
 Tag For B2

16 **TS31401H** - Jenny; Chair, High pressure laminate, No arms 4 1,094.80 4,379.20
EDGE: 6037 WINTER ON MAPLE
TOP-SURF: 2511 WINTER ON MAPLE
UPHLSTRY: 5999 MISC FABRIC
 CF STINSON INC - Acct 140021
 Purchaser: VENDOR
 Pattern: FUSE 2.0 -FSE
 Color: CHARCOAL -241
 Direction: HORIZONTAL

LEG OPT: *OPT:LEG OPTIONS

ALUMINUM: ALUMINUM LEGS

STEELCASE

Tag For B2

Qty Description

TITLE OF PRODUCT TRANSFERS UPON RECEIPT BY CUSTOMER.

91

ACCEPTED BY _____ TITLE _____ DATE _____

yourNBS.com

Remit Payments to: NBS, 6973 Reliable Parkway, Chicago, IL 60686

Description	Quantity	Unit Price	Extended Price	
16	4 COMMONS A101			
18	<p>LOT - Non-Union, normal hours. Receive, Deliver, and Installation of Product. One phase. Elevator access, as necessary Free and clear space No Removal of Existing Product</p> <p>Overtime Labor, if required, would be an additional charge.</p> <p>Storage free for 30 days. After which storage is charged per LF per month. ROSE MOVIN</p>	1	736.69	736.69
Sub Total			10,795.01	
Total			10,795.01	
Category A Erg				
19	<p>8306 - 8306/GD2 RAVEN 44"W STRAIGHT MODULAR UNIT SEAT HEIGHT: 18" BACK HEIGHT: 33" FABRIC: GRADE 5 BACK: CF STINSON FUSE 2.0 SLATE FSE-238 FABRIC DIR BACK: RAILROAD OR OFF THE BOLT TBD SEAT: CF STINSON FUSE 2.0 SLATE FSE-238 FABRIC DIR SEAT: RAILROAD OR OFF THE BOLT TBD LEGS: BRUSHED ALUMINUM GD2: FLAT GANGING DEVICE ERG INTERN</p> <p>Tag For A1</p>	6	1,713.04	10,278.24
	<p>Qty Description</p> <hr/> <p>6 Commons A101</p>			
20	<p>GD2 - FLAT GANGING DEVICE ERG INTERN</p> <p>Tag For A1</p>	5	52.43	262.15
21	<p>8302 - 8302/GD2 RAVEN 22"W STRAIGHT MODULAR UNIT SEAT HEIGHT: 18" BACK HEIGHT: 33" FABRIC: GRADE 5 BACK: CF STINSON FUSE 2.0 SLATE FSE-238 FABRIC DIR BACK: RAILROAD OR OFF THE BOLT TBD SEAT: CF STINSON FUSE 2.0 SLATE FSE-238 FABRIC DIR SEAT: RAILROAD OR OFF THE BOLT TBD LEGS: BRUSHED ALUMINUM</p>	2	1,038.80	2,077.60

TITLE OF PRODUCT TRANSFERS UPON RECEIPT BY CUSTOMER.

92

ACCEPTED BY _____ TITLE _____ DATE _____

Description	Quantity	Unit Price	Extended Price						
21 GD2: FLAT GANGING DEVICE ERG INTERN Tag For A2 <table border="0" style="margin-left: 40px;"> <tr> <td style="text-align: right;">Qty</td> <td>Description</td> </tr> <tr> <td style="border-top: 1px solid black; text-align: right;">2</td> <td style="border-top: 1px solid black;">Commons A101</td> </tr> </table>	Qty	Description	2	Commons A101					
Qty	Description								
2	Commons A101								
22 GD2 - FLAT GANGING DEVICE ERG INTERN Tag For A2	1	52.43	52.43						
23 8386 - 8386/GD2 RAVEN CORNER UNIT W/ SQUARE BACK SEAT HEIGHT: 18" BACK HEIGHT: 33" FABRIC: GRADE 5 BACK: CF STINSON FUSE 2.0 SLATE FSE-238 FABRIC DIR BACK: RAILROAD OR OFF THE BOLT TBD SEAT: CF STINSON FUSE 2.0 SLATE FSE-238 FABRIC DIR SEAT: RAILROAD OR OFF THE BOLT TBD GD2: FLAT GANGING DEVICE ERG INTERN Tag For A3 <table border="0" style="margin-left: 40px;"> <tr> <td style="text-align: right;">Qty</td> <td>Description</td> </tr> <tr> <td style="border-top: 1px solid black; text-align: right;">3</td> <td style="border-top: 1px solid black;">Commons A101</td> </tr> </table>	Qty	Description	3	Commons A101	3	1,810.06	5,430.18		
Qty	Description								
3	Commons A101								
24 GD2 - FLAT GANGING DEVICE ERG INTERN Tag For A3	2	52.43	104.86						
25 CAP105-LAM - CAPRI TABLE TABLE W/ LAMINATE TOP TABLE HEIGHT: 26" BASE SHAPE: RECTANGLE TOP SHAPE: ALMOST RECTANGLE - 13"X18" LAMINATE: WILSONART MANITOBA MAPLE 7911-60 EDGE DETAIL: GR 6F .75" MULTIPLY FLAT EDGE STAIN: STANDARD TBD BASE: BRUSHED ALUMINUM ERG INTERN Tag For A4 <table border="0" style="margin-left: 40px;"> <tr> <td style="text-align: right;">Qty</td> <td>Description</td> </tr> <tr> <td style="border-top: 1px solid black; text-align: right;">6</td> <td style="border-top: 1px solid black;">Commons A101</td> </tr> <tr> <td style="text-align: right;">4</td> <td>Large Group Room B112</td> </tr> </table>	Qty	Description	6	Commons A101	4	Large Group Room B112	10	491.47	4,914.70
Qty	Description								
6	Commons A101								
4	Large Group Room B112								
26 DUN24D - DUNCAN 24"D OCCASIONAL TABLE TABLE HEIGHT: 18" LAMINATE: WILSONART MANITOBA MAPLE 7911-60 LEGS: BRUSHED ALUMINUM	1	1,027.04	1,027.04						

TITLE OF PRODUCT TRANSFERS UPON RECEIPT BY CUSTOMER.

Description	Quantity	Unit Price	Extended Price
26 ERG INTERN Tag For A5 <div style="margin-left: 100px;"> Qty Description <hr/> 1 Commons A101 </div>			
27 8380 - 8380/2FO RAVEN 48"W BACK TO BACK BANQUETTE SEAT HEIGHT: 18" BACK HEIGHT: 33" OVERALL DEPTH: 51.5" FABRIC: GRADE 6 BACK: DESIGNTEX BIG DOT SMOKE 3525-803 FABRIC DIR BACK: RAILROAD OR OFF THE BOLT TBD SEAT: CF STINSON FUSE 2.0 PEACOCK FSE 223 FABRIC DIR SEAT: RAILROAD OR OFF THE BOLT TBD LEGS: BRUSHED ALUMINUM 2FO: TWO FABRIC OPTION ERG INTERN Tag For A6 <div style="margin-left: 100px;"> Qty Description <hr/> 3 Commons A110 </div>	3	3,808.77	11,426.31
28 8372 - 8372/2FO RAVEN 48" W BANQUETTE SEAT HEIGHT: 18" BACK HEIGHT: 33" FABRIC: GRADE 6 BACK: DESIGNTEX BIG DOT SMOKE 3525-803 FABRIC DIR BACK: RAILROAD OR OFF THE BOLT TBD SEAT: CF STINSON FUSE 2.0 PEACOCK FSE 223 FABRIC DIR SEAT: RAILROAD OR OFF THE BOLT TBD LEGS: BRUSHED ALUMINUM 2FO: TWO FABRIC OPTION ERG INTERN Tag For A7 <div style="margin-left: 100px;"> Qty Description <hr/> 1 Commons A110 </div>	1	2,035.46	2,035.46
29 MON24D - MON42D/SF MONACO 42"D TABLE TABLE HEIGHT: 29" BASE SPREAD: 1-22"S BASE LAMINATE: WILSONART MANITOBA MAPLE 7911-60 EDGE DETAIL: GR 3A 3MM X 1.25" FLAT PVC EDGE COLOR: STANDARD TBD BASE: BRUSHED ALUMINUM SF: POWDERCOAT FINISH ERG INTERN Tag For A8	4	808.50	3,234.00

TITLE OF PRODUCT TRANSFERS UPON RECEIPT BY CUSTOMER.

Description	Quantity	Unit Price	Extended Price				
29 <table border="0" style="width: 100%;"> <tr> <td style="text-align: right;">Qty</td> <td>Description</td> </tr> <tr> <td style="text-align: right;">4</td> <td>Commons A110</td> </tr> </table>	Qty	Description	4	Commons A110			
Qty	Description						
4	Commons A110						
30 MON3048-PVC - MON3048/SF MONACO 30X48 TABLE TABLE HEIGHT: 29" BASE SPREAD: 2-17"SQ BASES LAMINATE: WILSONART MANITOBA MAPLE 7911-60 EDGE DETAIL: GR 3A 3MM X 1.25" FLAT PVC EDGE COLOR: STANDARD TBD BASE: BRUSHED ALUMINUM SF: POWDERCOAT FINISH ERG INTERN Tag For A9 <table border="0" style="width: 100%;"> <tr> <td style="text-align: right;">Qty</td> <td>Description</td> </tr> <tr> <td style="text-align: right;">4</td> <td>Commons A110</td> </tr> </table>	Qty	Description	4	Commons A110	4	795.27	3,181.08
Qty	Description						
4	Commons A110						
31 DAK48D-PVC - DAK48D/CAS3/FLIPX DAKOTA 48"D TABLE TABLE HEIGHT: 29" BASE SPREAD: 1-38"X BASE LAMINATE: WILSONART MANITOBA MAPLE 7911-60 EDGE DETAIL: GR 3A 3MM X 1.25" FLAT PVC EDGE COLOR: STANDARD TBD BASE: BRUSHED ALUMINUM CAS3: 3"D BLACK LOCKING CASTERS FLIPX: FLIP TOP MECHANISM ERG INTERN Tag For A10 <table border="0" style="width: 100%;"> <tr> <td style="text-align: right;">Qty</td> <td>Description</td> </tr> <tr> <td style="text-align: right;">12</td> <td>Large Group Room B112</td> </tr> </table>	Qty	Description	12	Large Group Room B112	12	1,108.87	13,306.44
Qty	Description						
12	Large Group Room B112						
32 LOT - Non-Union, normal hours. Receive, Deliver, and Installation of Product. One phase. Elevator access, as necessary Free and clear space No Removal of Existing Product Overtime Labor, if required, would be an additional charge. Storage free for 30 days. After which storage is charged per LF per month. ROSE MOVIN	1	3,798.54	3,798.54				
Sub Total			61,129.03				
Total			61,129.03				
33 CONTINGENCY - Estimating 3-4 days for install If due to unforeseen circumstances the building is not ready to TITLE OF PRODUCT TRANSFERS UPON RECEIPT BY CUSTOMER.	1	N/C	N/C				



2595 Bellingham • Troy, MI 48083 • 248.823.5400 • 248.823.5401 Fax
 2211 Old Earhart Rd. Ste.190 • Ann Arbor, MI 48105 • 248.823.5400 • 248.823.5401 Fax
 3201 Pine Tree Rd. Ste. A • Lansing, MI 48911 • 517.886.0072 • 248.823.5401 Fax
 5160 Alliance Dr. • Bay City, MI 48706 • 989.895.8574 • 989.895.8545 Fax
 4 North St. Clair St. • Toledo, OH 43604 • 419.662.2040 • 248.823.5401 Fax

Quotation 357940
 Page 10 / 10 (cont'd)

yourNBS.com

Remit Payments to: NBS, 6973 Reliable Parkway, Chicago, IL 60686

Description	Quantity	Unit Price	Extended Price
<p>33 receive furniture, including construction delays, additional fees may be incurred to double handle and/or store the furniture. Installation is quoted as one phase.</p> <p>Additional Trip charge cost to return to site and complete installation: \$300</p> <p>Storage fee per month: \$1365 for all product ROSE MOVIN</p>			

Quotation Totals	
Sub Total	135,796.40
Grand Total	135,796.40

End of Quotation

TITLE OF PRODUCT TRANSFERS UPON RECEIPT BY CUSTOMER.

ACCEPTED BY _____ TITLE _____ DATE _____

FAMILIAL RELATIONSHIP DISCLOSURE STATEMENT

As required by Public Act 232 of 2004, all bids shall be accompanied by a sworn and notarized statement disclosing any familial relationship that exists between the owner or any employee of the bidder and any member of the Northville Public Schools Board of Education or the Superintendent of Schools. The Board of Education shall not accept a bid that does not include this sworn and notarized disclosure statement.

The undersigned, the owner or authorized officer of NBS (the "Bidder"), pursuant to the familial disclosure requirement provided in the Livonia Public Schools advertisement for construction bids, hereby represent and warrant, except as provided below, that no familial relationships exist between the owner(s) or any employee of the company and any member of the Livonia Public Schools Board of Education or the Superintendent of Schools. If such a relationship exists, please explain:

Attach additional pages if necessary

By: [Signature] (Bidder Signature)
Title: workplace specialist (type or print)
Date: 12/20/22

Subscribed and Sworn to Before Me:

This 20th day of December, 2022 A.D., in and for the
County of Oakland, Michigan.

My Commission expires 2/7/27.

[Signature]
Signature of Notary

BRETT BARKACS
NOTARY PUBLIC - STATE OF MICHIGAN
COUNTY OF OAKLAND
My Commission Expires February 7, 2027
Acting in the County of Oakland

NON-COLLUSION AFFIDAVIT

STATE OF MICHIGAN)
)
WAYNE COUNTY) ss:

The undersigned bidder or agent, being duly sworn on oath, says that he/she has not, nor has any other member, representative, or agent of the firm, company, corporation or partnership represented by him/her, entered into any combination, collusion or agreement with any person relative to the price to be bid by anyone at such letting nor to prevent any person from bidding nor to induce anyone to refrain from bidding, and that this bid is made without reference to any other bid and without any agreement, understanding or combination with any other person in reference to such bidding.

He/she further says that no person or persons, firms, or corporation has, have or will receive directly or indirectly, any rebate, gift, fee, commission or thing of value on account of such sale.

NBS

Bidder (Firm)

Signature of Bidder or Agent

Subscribed and sworn to before me this 29th day of December, 2022.

My commission expires: 2/7/27

County of residence: Oakland



Notary Public Signature

Seal

BRETT BARKACS
NOTARY PUBLIC – STATE OF MICHIGAN
COUNTY OF OAKLAND
My Commission Expires February 7, 2027
Acting in the County of Oakland

CERTIFICATION OF COMPLIANCE – IRAN ECONOMIC SANCTIONS ACT
Michigan Public Act No. 517 of 2012

The undersigned, the owner, or authorized officer of the below-named company (the "Company"), pursuant to the compliance certification requirement provided in the Livonia Public Schools Request For Proposal (the "RFP"), hereby certifies, represents, and warrants that the Company (which includes its officers, directors and employees) is not an "Iran Linked Business" within the meaning of the Iran Economic Sanctions Act, Michigan Public Act No. 517 of 2012 (the "Act"), and that in the event the Company is awarded a contract by the Livonia Public Schools Board of Education as a result of the aforementioned RFP, the Company is not and will not become an "Iran Linked Business" at any time during the course of performing any services under the contract.

The Company further acknowledges that any person who is found to have submitted a false certification is responsible for a civil penalty of not more than \$250,000.00 or two (2) times the amount of the contract or proposed contract for which the false certification was made, whichever is greater, the cost of the Livonia Public Schools' investigation, and reasonable attorney fees, in addition to the fine. Moreover, any person who submitted a false certification shall be ineligible to bid on a request for proposal for three (3) years from the date that it is determined that the person has submitted the false certification.

NBS
Name of Company
Anne Marie Trembuth
workplace Specialist
Name and Title of Authorized Representative

[Signature]
Signature

12/20/22
Date

END OF SECTION



QUOTATION: 22CAH-607768/C

Livonia Stem - Dec 16

CREATED 11/1/2022 | REVISED 1/11/2023 | Valid Through 2/28/2023



Livonia Stem - Dec 16

KI is pleased to present the enclosed quotation. The following items are included:

- Quote
- Summary
- Itemized Quote
- Detailed PO requirements
- Product Options

Quote Number: 22CAH-607768/C

CREATED 11/1/2022 | REVISED 1/11/2023 | Valid Through 2/28/2023

PRODUCT TOTALS	\$28,613.12
See Quote Detail Summary	\$0.00
GRAND TOTAL	\$28,613.12

Contract Information:

OT8142BZ1 Sourcewell #121919-KII -Delv/Inst

Requested Delivery Date: To be Determined

Sold To

Livonia Public Schools
 15125 Farmington Rd
 Livonia, MI 48154
 P. (734) 744-2500 F. (734) 744-2570

End User

Livonia Public Schools
 15125 Farmington Rd
 Livonia, MI 48154
 P. (734) 744-2500 F. (734) 744-2570

Ship To

To be Determined

Installation

To be Determined

Sales Team:

Chris Halatek
 Dealer Rep
 chris.halatek@ki.com
 248-408-0978



Daryl Wendt
 Inside Sales
 daryl.wendt@ki.com
 (877) 639-0643







Client Notes:

Delivered and Installed Normal Hours M-F
 Sourcewell KI Contract

CREATED 11/1/2022
VALID THROUGH 2/28/2023
Prepared By Chris Halatek
Quote Filename Livonia Stem - Dec 16 - 22CAH-607768/C



Line	Model	Qty.	Sell Price	Extended Total	TBD Options
Tag 1: Category E					
2.1	DN4100H30 S22348645	6	\$294.00	\$2,264.00	
	*Modified-Doni Four-Leg Armless 30" Stool,Poly,Solid Color				
	Poly Seat & Back Color	Compliance to TB 117-2013	/NFR		
	Poly Seat & Back Color NFR	NA	NA		
	Poly Seat & Back Color NFR	PSK Sky Blue	*Modified		
	Poly Seat & Back Color NFR	Per Order Net Upcharge	Per Order One Time 500.00		
			Charge for Setup Chg		
	Frame Color	Starlight Silver Metallic	Fee		
	Glide Option	Felt glides	/SX		
		Additional 15 working days lead-time is required	/GFT		
		NON-STANDARD POLY- \$500 Setup Fee. If SKU total on order exceeds 100 units, fee will be waived (SKU=Product/Color)	Note: Lead-time Change External Note		
	MK: E1 Price Description: Delivered/Open Market Lead Time: 6 - 8 Weeks; Ships from GREEN BAY, WI Please Note: Leadtime calculated on 1/11/2023 and is subject to change.				
2.4	DN4100H30	12	\$294.00	\$3,528.00	
		Doni Four-Leg Armless 30" Stool,Poly,Solid Color			
	Poly Seat & Back Color	Compliance to TB 117-2013	/NFR		
	Poly Seat & Back Color NFR	Zesty Lime	/PZL		
	Frame Color	Starlight Silver Metallic	/SX		
	Glide Option	Steel glides	/GSL		
	MK: E2 Price Description: Delivered/Open Market Lead Time: 3 - 5 Weeks; Ships from GREEN BAY, WI Please Note: Leadtime calculated on 1/11/2023 and is subject to change.				
2.5	RKT301841OP/36T	3	\$903.84	\$2,711.52	
		Ruckus,Tote Storage,Tall,2-Column unit,Open,30"Wx18"Dx40-3/4"H,includes (10)3" totes,(4)6"totes			
	Storage Base	4 black casters	/4CW		
	Paint Color	Sky Blue	/SK		
	MK: E3 Price Description: Delivered/Open Market Lead Time: 4 - 6 Weeks; Ships from PEMBROKE, ONT Please Note: Leadtime calculated on 1/11/2023 and is subject to change.				
2.6	RKT301841DR/36T	2	\$1,057.28	\$2,114.56	
		Ruckus,Tote Storage,Tall,2-Column unit,w/Doors,30"Wx18"Dx40-3/4"H,includes (10)3" totes,(4)6"totes			
	Pull Option	Beveled pull Satin Chrome	/S5		
	Storage Base	4 black casters	/4CW		
	Paint Color	Sky Blue	/SK		
	Door Color	Sky Blue	/FSK		
	Lock Option	Key alike	/KA		
	Lock Color	Satin Chrome	/SCL		
	National Key Alike	Key Alike Lock #116	/L116		
	MK: E4 Price Description: Delivered/Open Market Lead Time: 4 - 6 Weeks; Ships from PEMBROKE, ONT Please Note: Leadtime calculated on 1/11/2023 and is subject to change.				

CREATED 11/1/2022
VALID THROUGH 2/28/2023
Prepared By Chris Halatek
Quote Filename Livonia Stem - Dec 16 - 22CAH-607768/C

Line	Model		Qty.		Sell Price	Extended Total	TBD Options
2.7	RKT301841DR/XT	Ruckus,Tote Storage,Tall,2-Column unit,w/Doors,30"Wx18"Dx40-3/4"H,Empty (Totes Must be Ordered Separately)	3		\$856.24	\$2,568.72	
		Pull Option Beveled pull Satin Chrome /S5 Storage Base 4 black casters /4CW Paint Color Sky Blue /SK Door Color Sky Blue /FSK Lock Option Key alike /KA Lock Color Satin Chrome /SCL National Key Alike Key Alike Lock #116 /L116 MK: E5 Price Description: Delivered/Open Market Lead Time: 4 - 6 Weeks; Ships from PEMBROKE, ONT Please Note: Leadtime calculated on 1/11/2023 and is subject to change.					
2.8	RKATSSHELF S22348647	*Modified-Ruckus Tote storage removeable steel shelf with rail set	3		\$32.48	\$97.44	
		Paint Color NA Paint Color SKY BLUE *Modified Additional 10 working days lead-time is required Note: Lead-time Change MK: E5 Price Description: Delivered/Open Market Lead Time: 6 - 8 Weeks; Ships from PEMBROKE, ONT Please Note: Leadtime calculated on 1/11/2023 and is subject to change.					
2.9	RKT301841DR/XT	Ruckus,Tote Storage,Tall,2-Column unit,w/Doors,30"Wx18"Dx40-3/4"H,Empty (Totes Must be Ordered Separately)	2		\$856.24	\$1,712.48	
		Pull Option Beveled pull Satin Chrome /S5 Storage Base 4 black casters /4CW Paint Color Sky Blue /SK Door Color Sky Blue /FSK Lock Option Key alike /KA Lock Color Satin Chrome /SCL National Key Alike Key Alike Lock #116 /L116 MK: E6 Price Description: Delivered/Open Market Lead Time: 4 - 6 Weeks; Ships from PEMBROKE, ONT Please Note: Leadtime calculated on 1/11/2023 and is subject to change.					
2.10	RKT301828OP/36T	Ruckus,Tote Storage,Short,2-Column Unit,Open,30"Wx18"Dx27-3/4"H,includes (8)3" totes,(2)6" totes	3		\$751.52	\$2,254.56	
		Storage Base 4 black casters /4CW Paint Color Sky Blue /SK MK: E7A Price Description: Delivered/Open Market Lead Time: 4 - 6 Weeks; Ships from PEMBROKE, ONT Please Note: Leadtime calculated on 1/11/2023 and is subject to change.					
2.11	RKT301828OP/3T	Ruckus,Tote Storage,Short,2-Column unit,Open,30"Wx18"Dx27-3/4"H,includes (12)3" Totes	3		\$762.16	\$2,286.48	
		Storage Base 4 black casters /4CW Paint Color Sky Blue /SK MK: E7B Price Description: Delivered/Open Market Lead Time: 4 - 6 Weeks; Ships from PEMBROKE, ONT Please Note: Leadtime calculated on 1/11/2023 and is subject to change.					



CREATED 11/1/2022
VALID THROUGH 2/28/2023
Prepared By Chris Halatek
Quote Filename Livonia Stem - Dec 16 - 22CAH-607768/C

Line	Model	Qty.	Sell Price	Extended Total	TBD Options
2.12	RKT301828OP/6T  Ruckus, Tote Storage, Short, 2-Column Unit, Open, 30"Wx18"Dx27-3/4"H, includes (6) 6" Totes Storage Base 4 black casters /4CW Paint Color Sky Blue /SK MK: E7C Price Description: Delivered/Open Market Lead Time: 4 - 6 Weeks; Ships from PEMBROKE, ONT Please Note: Leadtime calculated on 1/11/2023 and is subject to change.	4	\$707.84	\$2,831.36	
2.14	618WA  600 Series Industrial Stool, Wood Seat, Adj Ht, 19-27"H Stool Frame Color Warm Grey /WG MK: E8 Price Description: Delivered/Open Market Lead Time: 4 - 6 Weeks; Ships from BONDUEL, WI Please Note: Leadtime calculated on 1/11/2023 and is subject to change.	50	\$124.88	\$6,244.00	
Tag 1: Category E				WorkGroup Product Subtotal	\$28,613.12

Quote Summary

Product SubTotal: \$28,613.12
Estimated Sales Tax: See Notes
Quote Total: \$28,613.12

NOTES:

- Images shown above are intended for approximate visual reference only and may not represent the exact models, numbers, descriptions or options selected. Refer to the model number/description/options shown for full product specifications.
- Sales Tax (For Shipment within the United States Only): Estimated sales/use tax will be calculated when order is entered. It is the customer's responsibility to pay any applicable sales/use tax due upon invoicing. A customer will not be charged sales tax if (1) a Resale Certificate, (2) an Exempt Organization Certificate, or (3) a Direct Pay permit is on file with KI's Finance Department. If no certificate is on file, the appropriate sales/use tax rate in effect at shipment will be applied and tax will be added to the customer's invoice.
- This project contains non-standard items which are not returnable and not cancelable. The warranty on non-standard product that alters function is 1 year. The warranty on non-standard product that does not alter function, but only finish (i.e., paint or plastic color, laminate, grommet removal) matches that of the standard product. Modification to U.L. Listed products eliminates the listing. Product will not have U.L. Listing labels unless specifically spelled out on this quote.

PROJECT LEAD TIME SUMMARY:

- Manufacturing lead time begins once the order is complete and acknowledged. Delivery dates are determined per order based on the longest lead time per shipping location and are confirmed on the order acknowledgement.

<u>Shipping Location</u>	<u>MFG Lead Time Range</u>
BONDUEL, WI	4 - 6 Weeks
GREEN BAY, WI	6 - 8 Weeks
PEMBROKE, ONT	6 - 8 Weeks
- Lead times are subject to change based on quantities, manufacturing capacity and surface material selections. Laminate and/or fabrics outside the standard KI in-grade program may have extended lead time.
- For more information or questions regarding delivery consolidation, contact KI Customer Service.

Customer represents that the product information contained within this quote is complete and accurate. Changes to quantities and/or options/finishes will affect this quote. If applicable, other charges such as freight, tax, installation and/or delivery fees may be added at time of order.

Sales resulting from purchase orders issued by the customer to KI (Whether related to this quotation or otherwise) are governed and controlled by the Terms and Conditions found at www.KI.com/terms

Prepared by Chris Halatek
Market Code: 2=2=K-12

Opportunity #: 607768

Quote Filename: Livonia Stem - Dec 16 - 22CAH-607768

Final Considerations:

To ensure your Purchase Order (PO) is processed quickly and efficiently, please adhere to the following requirements:

1. All purchase orders must be issued to KI or KI c/o the dealer with this address:
KI
1330 Bellevue Street
Green Bay, WI 54302
2. The following items must be included on all purchase orders:
 - Sold To/Bill To Information: complete legal name, address, telephone number and fax number
 - Ship To Information: complete legal name, address, contact name, contact phone number
 - Purchase Order Number: a customer-specific identifier, typically a sequential purchase order number or requisition number
 - Issue Date: date the purchase order was issued
 - Sales Tax: applicable sales tax will be added upon KI invoicing. If tax exempt, customer must provide or have the tax exempt certificate on file at KI
 - Purchase Order Total: total of all items and services included on the purchase order
 - Authorization: signature of authorized purchasing agent or buying entity
 - Order Details: reference a fully optioned KI quote (ex: 11KGH-85432) or include all the information listed below
 - Quantity of each item
 - Complete model number, including all finish and option information (by line item)
 - Net purchase price (by line item)
 - Extended net purchase price (all line items)
 - Any additional applicable charges (ex: installation and/or delivery charges)
 - Contract name and/or number if pricing is based on a contract reference
3. Signatures on a quote or a worksheet cannot be accepted as a purchase order.
4. In the event that you do not have a formal Purchase Order process, please contact your KI Sales Representative or call 1-800-424-2432, and we will assist you with creating a PO.

We appreciate your cooperation in providing us with all the required information listed above on your Purchase Order. Complete information helps us serve you better. Thank you for your order.

Purchase Orders that do not meet these requirements will be placed on hold until complete information is received by KI. Purchase orders on hold are not released to manufacturing or assigned a delivery date. KI order lead times begin once the order is released to manufacturing.

FAMILIAL RELATIONSHIP DISCLOSURE STATEMENT

As required by Public Act 232 of 2004, all bids shall be accompanied by a sworn and notarized statement disclosing any familial relationship that exists between the owner or any employee of the bidder and any member of the Northville Public Schools Board of Education or the Superintendent of Schools. The Board of Education shall not accept a bid that does not include this sworn and notarized disclosure statement.

The undersigned, the owner or authorized officer of Interior Office Source Inc. (the "Bidder"), pursuant to the familial disclosure requirement provided in the Livonia Public Schools advertisement for construction bids, hereby represent and warrant, except as provided below, that no familial relationships exist between the owner(s) or any employee of the company and any member of the Livonia Public Schools Board of Education or the Superintendent of Schools. If such a relationship exists, please explain:

Attach additional pages if necessary

By: [Signature] (Bidder Signature)
Title: PRESIDENT (type or print)
Date: 12-19-22

Subscribed and Sworn to Before Me:

This 19th day of December, 2022 A.D., in and for the
County of Livingston, Michigan.

My Commission expires 09/09/2027

Melanie Alice Murrell
Signature of Notary

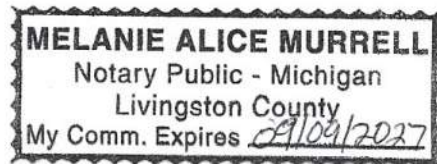

NON-COLLUSION AFFIDAVIT

STATE OF MICHIGAN)
)
WAYNE COUNTY) ss:

The undersigned bidder or agent, being duly sworn on oath, says that he/she has not, nor has any other member, representative, or agent of the firm, company, corporation or partnership represented by him/her, entered into any combination, collusion or agreement with any person relative to the price to be bid by anyone at such letting nor to prevent any person from bidding nor to induce anyone to refrain from bidding, and that this bid is made without reference to any other bid and without any agreement, understanding or combination with any other person in reference to such bidding.

He/she further says that no person or persons, firms, or corporation has, have or will receive directly or indirectly, any rebate, gift, fee, commission or thing of value on account of such sale.

INTERIOR OFFICE SOURCE
Bidder (Firm)

Signature of Bidder or Agent

Subscribed and sworn to before me this 19th day of December, 2022

My commission expires: 09/09/2027

County of residence: Livingston

Melanie Alice Murrell
Notary Public Signature

Seal



CERTIFICATION OF COMPLIANCE – IRAN ECONOMIC SANCTIONS ACT
Michigan Public Act No. 517 of 2012

The undersigned, the owner, or authorized officer of the below-named company (the "Company"), pursuant to the compliance certification requirement provided in the Livonia Public Schools Request For Proposal (the "RFP"), hereby certifies, represents, and warrants that the Company (which includes its officers, directors and employees) is not an "Iran Linked Business" within the meaning of the Iran Economic Sanctions Act, Michigan Public Act No. 517 of 2012 (the "Act"), and that in the event the Company is awarded a contract by the Livonia Public Schools Board of Education as a result of the aforementioned RFP, the Company is not and will not become an "Iran Linked Business" at any time during the course of performing any services under the contract.

The Company further acknowledges that any person who is found to have submitted a false certification is responsible for a civil penalty of not more than \$250,000.00 or two (2) times the amount of the contract or proposed contract for which the false certification was made, whichever is greater, the cost of the Livonia Public Schools' investigation, and reasonable attorney fees, in addition to the fine. Moreover, any person who submitted a false certification shall be ineligible to bid on a request for proposal for three (3) years from the date that it is determined that the person has submitted the false certification.

INTERIOR OFFICE SOURCE
Name of Company

JOHN J. REIS PRESIDENT
Name and Title of Authorized Representative

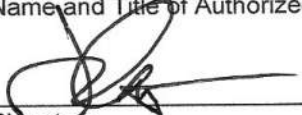
Signature

12-19-22
Date

END OF SECTION



2195 South Milford Road, Milford MI 48381 Tel: 810-599-68

Date: 12/30/2022

Customer:	Livonia Public School	Job Info:	Quote Number
Project Name:	Livonia CTC Robotics Addition Furnishing:	Contact: Chris Halatek	
Address:	8985 Newburgh Road	Contact Number: 248-408-0978	Ship to: 2195 S Milford Road
City, State Zip:	Livonia, MI 48150	Contact Email : chris.halatek@interiorofficesource.com	Suite E
Email:		Customer PO	Milford MI 48381
Phone:		Vendor Wisconsin Bench	
		Contract Peppm	PA- 528897-298
Project Number	TMP 20136A Category F	Terms Net 30	

Product Information:

Quantity:	Model #		Finishes	Sell Each:	Extended Sell
10	TOR9107-ASJG4-M-FJ	Toro Table with True Maple Top 48 x 48" D with Maple Butcher Block 1.75" Thick Top 1.5" Square Adjustable Leg 22-38"H Non Maring Nylon Glide TAG F1	True Maple Hard Block Paint Silver G4	\$ 1,658.00	\$ 16,580.00
7	TOR9069-ADJG4-M	Toro Table with True Maple Top 24 x 48" D with Maple Butcher Block 1.75" Thick Top 1.5" Square Adjustable Leg 22-38"H With Half Shelf CSHF Centered Non Maring Nylon Glide TAG F2	True Maple Hard Block Paint Silver G4	\$ 1,607.00	\$ 11,249.00
2	TOR9070ADJG4-M-HSHF 24	Toro Table with True Maple Top 24" x 54" D with Maple Butcher Block 1.75" Thick Top 1.5" Square Adjustable Leg 22-38"H Non Maring Nylon Glide TAG F3	True Maple Hard Block Paint Silver G4	1095.75	\$ 2,191.50
4	TOR9092-ADJG4-M-HSHF	Toro Table with True Maple Top 36 x 60" D with Maple Butcher Block 1.75" Thick Top 1.5" Square Adjustable Leg 22-38"H With Half Shelf CSHF Centered Non Maring Nylon Glide TAG F4	True Maple Hard Block Paint Silver G4	1924.75	\$ 7,699.00
		Installation 2023 Freight Included with PEPPM			\$ 2,100.00
		Quote expires 30 days		\$ 6,285.50	\$ 39,819.50

09



Customer: Livonia Public School District
Project Name: CTC Robotics aAddition Furnishings
Address: 8985 Newburgh Road
City, State Zip: Livonia, MI 48154
Email:
Phone:
Category TMP: H
Project Number: 21036A

Job Info:
Contact: Chris Halatek
Contact Number: 248-408-0978
Contact Email : chris.halatek@interiorofficesource.com
Customer PO: 2020-00001407
Vendor: [Fleetwood Furniture](#)
Contract: NCPA 07-27
Terms: Net 30

Quote Number: FT21036A
Date: 12/30/2002
Ship to: The Interior Group

Product Information:

Quantity:	Model #		Finishes	Sell Each:	Extended Sell
3	25RS640	Tables Butcher Block top 60 W x 42D x 27-38.5H Adjustable Height with Crank	Maple Top	\$ 2,526.00	\$ 7,578.00
			Silver Paint		
		Tag H1			
		PO to Interior Office Source			
3		Installation First Floor, M-F 7AM - 3PM Freight Included with NCPA Contract Net 30			\$ 500.00
		Pricing expires in 60 Days			110
				\$	8,078.00



Livonia Public Schools

PRICE PROPOSAL

Date: 1/3/2023

Quote Number: 1713-26664

Valid For 25 Days

Prepared by: Steve Timmer

Confidential

© 2023 Dew-El Corporation. The information in this transmittal is proprietary to Dew-El Corporation. It is provided on the condition that it remains in confidence between Dew-El Corporation and the recipient of this quote. Do Not Copy, Distribute nor Share the Contents of this proposal without the written permission of Dew-El Corporation.

Project Scope

Bill To

Livonia Public Schools
 15125 Farmington Road
 Livonia, MI 48154

Install To

Livonia Career Technical Center
 8985 Newburgh Rd
 Livonia, MI 48150

Project Investment

Project Total	\$3,836.14
Tax (0%)	\$0.00
Grand Total	\$3,836.14

Payment Schedule

100% Due Net 30	Net 30 \$3,836.14
-----------------	-----------------------------

Price Summary by Phase

Option	Phase / TAG	Price	Tax	Total
Livonia CTC and Robotics	Commons A101	\$2,936.14	\$0.00	\$2,936.14
	Freight	\$400.00	\$0.00	\$400.00
	Installation	\$500.00	\$0.00	\$500.00
		\$3,836.14	\$0.00	\$3,836.14
Grand Total		\$3,836.14	\$0.00	\$3,836.14

Dew-El Corporation
 10841 Paw Paw Drive
 Holland, MI 49424
 Phone: (616) 396-6554
 Fax: (616) 396-6669
 http://www.Dew-El.com



QUOTATION

1713-26664

VALID UNTIL 1/28/2023

BILL TO

Livonia Public Schools
 15125 Farmington Road
 Livonia, MI 48154

INSTALL TO



Livonia Career Technical Center
 8985 Newburgh Rd
 Livonia, MI 48150

Salesperson
 Steve Timmer

Payment Terms
 Net 30

Livonia CTC and Robotics

Commons A101

LINE #	QTY	UNIT	PART # / DESCRIPTION	PRICE EA	EXT PRICE
1	2.00	EA	CBLOX-17-17-G3 / Blox Seating - Cylinder 17" Dia x 17"H, Grade 3 High-Density Foam Interior, Grade 2 Fabric Exterior Cylinder Shape Fabric: Designtex Rise Penny 3809-701 Tag: G1	\$375.50	\$751.01
					
2	2.00	EA	CBLOX-17-17-G3 / Blox Seating - Cylinder 17" Dia x 17"H, Grade 3 High-Density Foam Interior, Grade 2 Fabric Exterior Cylinder Shape Fabric: Designtex Rise Grass 3809-502 Tag: G2	\$375.50	\$751.01
					
3	1.00	EA	CBLOX-17-17-G3 / Blox Seating - Cylinder 17" Dia x 17"H, Grade 3 High-Density Foam Interior, Grade 2 Fabric Exterior Cylinder Shape Fabric: Designtex Rise Pool 3809-403 Tag: G3	\$375.51	\$375.51
					
4	2.00	EA	CBLOX-17-17-G8 / Blox Seating - Cylinder 17" Dia x 17"H, Grade 8 High-Density Foam Interior, Grade 2 Fabric Exterior Cylinder Shape Fabric: CF Stinson La Scalina LAS14 Flow Tag: G4	\$529.30	\$1,058.61
					

Freight

LINE #	QTY	UNIT	PART # / DESCRIPTION	PRICE EA	EXT PRICE
5	1.00	EA	Freight / Freight / Shipping / Packaging	\$400.00	\$400.00

Installation

LINE #	QTY	UNIT	PART # / DESCRIPTION	PRICE EA	EXT PRICE
6	1.00	EA	INSTALL / Labor to Receive, Deliver, Install, and remove debris	\$500.00	\$500.00

Dew-El Corporation
10841 Paw Paw Drive
Holland, MI 49424
Phone: (616) 396-6554
Fax: (616) 396-6669
<http://www.Dew-El.com>



QUOTATION

1713-26664

VALID UNTIL 1/28/2023

Livonia CTC and Robotics

CUSTOMER SIGN OFF

subtotal	\$3,836.14
sales tax	\$0.00
total	\$3,836.14

Authorized Signature

Accepted Date

Print Name

FAMILIAL RELATIONSHIP DISCLOSURE STATEMENT

As required by Public Act 232 of 2004, all bids shall be accompanied by a sworn and notarized statement disclosing any familial relationship that exists between the owner or any employee of the bidder and any member of the Northville Public Schools Board of Education or the Superintendent of Schools. The Board of Education shall not accept a bid that does not include this sworn and notarized disclosure statement.

The undersigned, the owner or authorized officer of Dew-EI Corporation (the "Bidder"), pursuant to the familial disclosure requirement provided in the Livonia Public Schools advertisement for construction bids, hereby represent and warrant, except as provided below, that no familial relationships exist between the owner(s) or any employee of the company and any member of the Livonia Public Schools Board of Education or the Superintendent of Schools. If such a relationship exists, please explain:

Attach additional pages if necessary

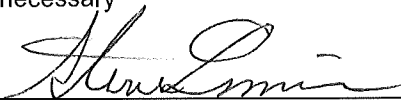
By: Steve Timmer  (Bidder Signature)

Title: Learning Environment Specialist (type or print)

Date: 12/21/2022

Subscribed and Sworn to Before Me:

This 22nd day of December, 2022 A.D., in and for the

County of Ottawa, Michigan.

My Commission expires 10-03-2023.



Signature of Notary

RAQUEL PENA ROSAS
Notary Public, State of Michigan
County of Ottawa
My Commission Expires 10/03/2023
Acting County of Ottawa

NON-COLLUSION AFFIDAVIT

STATE OF MICHIGAN)
)
WAYNE COUNTY) ss:

The undersigned bidder or agent, being duly sworn on oath, says that he/she has not, nor has any other member, representative, or agent of the firm, company, corporation or partnership represented by him/her, entered into any combination, collusion or agreement with any person relative to the price to be bid by anyone at such letting nor to prevent any person from bidding nor to induce anyone to refrain from bidding, and that this bid is made without reference to any other bid and without any agreement, understanding or combination with any other person in reference to such bidding.

He/she further says that no person or persons, firms, or corporation has, have or will receive directly or indirectly, any rebate, gift, fee, commission or thing of value on account of such sale.

Dew-EI Corporation

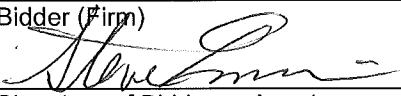
Bidder (Firm)

Signature of Bidder or Agent

Subscribed and sworn to before me this 22nd day of December, 20 22.

My commission expires: 10-03-2023

County of residence: Ottawa



Notary Public Signature

Seal

RAQUEL PENA ROSAS
Notary Public, State of Michigan
County of Ottawa
My Commission Expires 10/03/2023
Acting County of Ottawa

CERTIFICATION OF COMPLIANCE – IRAN ECONOMIC SANCTIONS ACT
Michigan Public Act No. 517 of 2012

The undersigned, the owner, or authorized officer of the below-named company (the "Company"), pursuant to the compliance certification requirement provided in the Livonia Public Schools Request For Proposal (the "RFP"), hereby certifies, represents, and warrants that the Company (which includes its officers, directors and employees) is not an "Iran Linked Business" within the meaning of the Iran Economic Sanctions Act, Michigan Public Act No. 517 of 2012 (the "Act"), and that in the event the Company is awarded a contract by the Livonia Public Schools Board of Education as a result of the aforementioned RFP, the Company is not and will not become an "Iran Linked Business" at any time during the course of performing any services under the contract.

The Company further acknowledges that any person who is found to have submitted a false certification is responsible for a civil penalty of not more than \$250,000.00 or two (2) times the amount of the contract or proposed contract for which the false certification was made, whichever is greater, the cost of the Livonia Public Schools' investigation, and reasonable attorney fees, in addition to the fine. Moreover, any person who submitted a false certification shall be ineligible to bid on a request for proposal for three (3) years from the date that it is determined that the person has submitted the false certification.

Dew-El Corporation
Name of Company

Steve Timmer
Name and Title of Authorized Representative

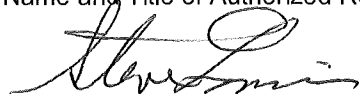
Signature

12/21/2022
Date

END OF SECTION



Dew-El Corporation would like to thank you for the opportunity to quote your furniture needs. The attached proposal outlines the specifications and pricing based on the information provided. By signing and returning this quote, you agree to be bound by the terms and conditions contained herein which shall become the fully integrated agreement between you, the Client, and Dew-El Corporation.

DELIVERY AND INSTALLATION

1. Delivery/installation services are performed during normal business hours Monday through Friday 8:00am to 5:00pm unless otherwise specified; Client may incur additional charges for services performed after hours and/or weekends. All labor is quoted as a single-phase installation unless noted otherwise. If additional trips or phases are required due to the Client not being prepared for delivery or the site not being ready, it may result in added cost to the labor quote. Product will be delivered and installed on a mutually agreed upon date. All available spaces must be ready for furniture; installation of all carpet, painting, lighting, and ceiling tiles must be completed. If delivery and/or installation are requested by the Client to an uncompleted space, Client accepts responsibility for any damage to or theft of the product. The Client may request partial delivery and/or installation when placing the order. If so, the Client agrees to both take delivery and pay for all delivered items on a partial basis.
2. Prior to the installation, Dew-El Corporation is to be informed of the following guidelines or restrictions for proper access to the building: dock accessibility, sidewalks, parking lots, elevator access above the first floor, time restrictions, security checks or any safety requirements needed for access to your facility during the time of the installation. Any notification that delivery and/or installation cannot be accepted must be communicated to Dew-El Corporation no later than 12:00pm on the business day prior to the scheduled delivery and/or installation date. Dew-El Corporation requests product to be shipped by our manufacturers according to customer needs. If a Client has requested product to be installed by a specific date, Dew-El Corporation will work with the manufacturer to have all product received in time for the installation date requested by the customer. Dew-El Corporation shall not be held liable for manufacturing/delivery delays outside of Dew-El Corporation's control. If for any reason the customer delays the original installation date, Dew-El Corporation reserves the right to invoice for all product shipped according to the customer requested delivery date.

SALES TAX

Prices quoted include sales tax, and taxes will be included upon invoicing, unless an exemption certificate is furnished by the Client. If tax-exempt, please send a copy of your exemption certificate along with your signed quote.

PAYMENT TERMS

1. The following estimate is valid for 30 days. Payment terms are net due 30 days from invoice date, which is initiated upon shipment and/or fulfillment of service.
2. In the event of project delays due to construction, trades or equipment, the Client is expected to bring payments to a net retainage of 90% of the estimate. The Client is permitted to hold as retainage an amount equal to the value of uncompleted work, damaged or incorrect items.
3. Should Client default in payment of this Contract, charges shall be added from the date of default at the rate of one and one half percent (1 1/2%) per month, (18% per annum).
4. Client agrees to pay a Transaction Convenience fee of three point eight percent (3.8%) of the sell price shown on the proposal (including applicable sales tax) when the method of payment is in any form other than Dew-El Corporation's standard payment methods, which include cash, check, or ACH/direct deposit.

ACCEPTANCE

All sales are final; specified product is non-returnable and non-refundable. Claims for defects, errors or shortages must be made in writing within twenty business days after delivery. Failure to make a claim within such period shall constitute acceptance of the items.

CANCELLATIONS AND CHANGES

To accept the following estimate, drawings, specifications and delivery and installation conditions please sign both below and the last page of the estimate. If a purchase order is required for payment, that order number must be provided at the time of order placement. Any change(s) to an existing order may incur additional fees once the order has been placed. Such charges may include but not limited to; date moves, product changes/deletions, and "ship to" changes. Your signature approves Dew-El Corporation Terms and Conditions stated above.

Authorized Signature _____ Date _____

Title _____ PO No. _____

Company _____

Pricing for Media Technologies is provided according to National Purchasing Contract NCPA #07-42



Proposal

Interior Environments - Novi
48700 Grand River Ave
Novi, MI 48374
Phone: (248) 213-3010

Order Number	12145
Date	01/05/2023
Customer PO No	
Customer Name	Livonia Public Schools
Salesperson	Bari Pfeiffer
Terms	NET 30
Page	1 of 6

T Livonia Public Schools
O 15125 Farmington Rd
 Livonia, MI 48154

ATTN: INVOICE CONTACT
 Email: ap@livoniapublicschools.org

S Livonia Career Technical Center
H 8985 Newburg Rd
I Livonia, MI 48150
P

T ATTN: Lauren Bush
O Phone: 248-338-4561
 Email: lbush@tmp-architecture.com

Prepared for : Bari Pfeiffer

Allsteel - Omnia Contract R191802
 Watson - NCPA 07-48

Due to the current challenges in the global supply chain and labor environment, pricing and lead times remain in a state of flux. Our team will do it's best to communicate any changes as they arise and provide the best available solutions to meet your needs. Thank you for your business and understanding.

Group	Quantity	Description	Unit Price	Extended Amount
ALLSTEEL	1.0		26,029.12	26,029.12

Line	Quantity	Description	Unit Price	Extended Amount
1	5.00 Each	Allsteel S922S2--.FSC-\$(5)-.FSE-238 Rise - 2 Tier .FSC:FSC Mixed Wood \$(5):Grade 5 Uph .FSE:Fuse 2.0 238:Slate Tag: Tag TG: LARGE GROUP ROOM B112 Tag L1: J1	1,645.42	8,227.10
2	3.00 Each	Allsteel S922S2--.FSC-\$(5)-.FSE-227 Rise - 2 Tier .FSC:FSC Mixed Wood \$(5):Grade 5 Uph .FSE:Fuse 2.0 227:Chive Tag: Tag TG: LARGE GROUP ROOM B112 Tag L1: J2	1,645.42	4,936.26
3	1.00 Each	Allsteel S922S3--.FSC-\$(5)-.FSE-227 Rise- 3 Tier .FSC:FSC Mixed Wood \$(5):Grade 5 Uph .FSE:Fuse 2.0 227:Chive Tag: Tag TG: LARGE GROUP ROOM B112 Tag L1: J3	1,810.06	1,810.06
4	2.00 Each	Allsteel S922S3--.FSC-\$(5)-.FSE-223	1,810.06	3,620.12



Proposal

Interior Environments - Novi
 48700 Grand River Ave
 Novi, MI 48374
 Phone: (248) 213-3010

Order Number	12145
Date	01/05/2023
Customer PO No	
Customer Name	Livonia Public Schools
Salesperson	Bari Pfeiffer
Terms	NET 30
Page	2 of 6

		Rise- 3 Tier .FSC:FSC Mixed Wood \$(5):Grade 5 Uph .FSE:Fuse 2.0 223:Peacock Tag: Tag TG: LARGE GROUP ROOM B112 Tag L1: J4		
5	2.00 Each	Allsteel S922S2IC--.FSC-\$(5)-.FSE-223 2-Tier Inside Corner Rise .FSC:FSC Mixed Wood \$(5):Grade 5 Uph .FSE:Fuse 2.0 223:Peacock Tag: Tag TG: LARGE GROUP ROOM B112 Tag L1: J5	2,224.11	4,448.22
6	1.00 Each	Rose Moving and Storage LABOR---- INSTALLATION :(8) 2 TIER RISE :(3) 3 TIER RISE :(2) 2 TIER INSIDE CORNER RISE Tag: Tag TG: LARGE GROUP ROOM B112 Tag L1: GROUP J	1,855.00	1,855.00
7	1.00 Each	Allsteel TARIFF ALLSTEEL TARIFF Tag: Tag TG: LARGE GROUP ROOM B112 Tag L1: GROUP J	1,132.36	1,132.36

Group	Quantity	Description	Unit Price	Extended Amount
WATSON	1.0		13,344.41	13,344.41

Line	Quantity	Description	Unit Price	Extended Amount
9	11.00 Each	Watson Furniture Group WEM204660M--SAP ETCH MOBILE MARKERBOARD, 20"D x 46"W x 60"H SAP:POWDER FINISH- Sapphire Tag: Tag TG: (2) COMMONS A101, (6) ROBOTICS STUDIO A124, (1) COMMONS A110, (2) LARGE GROUP B112 Tag L1: K1	958.50	10,543.50
10	11.00 Each	Watson Furniture Group WEMC020304--SAP ETCH MARKER CUP, 2"D x 3"W x 4"H SAP:POWDER FINISH- Sapphire Tag: Tag TG: (2) COMMONS A101, (6) ROBOTICS STUDIO A124, (1) COMMONS A110, (2) LARGE GROUP B112 Tag L1: K1	45.00	495.00
11	1.00	Rose Moving and Storage	1,570.00	1,570.00



Proposal

Interior Environments - Novi
48700 Grand River Ave
Novi, MI 48374
Phone: (248) 213-3010

Order Number	12145
Date	01/05/2023
Customer PO No	
Customer Name	Livonia Public Schools
Salesperson	Bari Pfeiffer
Terms	NET 30
Page	3 of 6

	Each	LABOR--- INSTALLATION :(11) ETCH MOBILE MARKERBOARD :(11) ETCH MARKER CUP Tag: Tag TG: (2) COMMONS A101, (6) ROBOTICS STUDIO A124, (1) COMMONS A110, (2) LARGE GROUP B112 Tag L1: GROUP K		
12	1.00 Each	Watson Furniture Group TARIFF WATSON TARIFF Tag: Tag TG: (2) COMMONS A101, (6) ROBOTICS STUDIO A124, (1) COMMONS A110, (2) LARGE GROUP B112 Tag L1: GROUP K	735.91	735.91

Order Sub-Total :	\$39,373.53
TOTAL ORDER :	\$39,373.53
Required Deposit 50.0% :	\$19,686.77

PLEASE REVIEW THIS QUOTATION AND NOTIFY US PROMPTLY OF ANY CORRECTIONS REQUIRED THANK YOU FOR THE OPPORTUNITY TO BE OF SERVICE

A FINANCE CHARGE OF 1-1/2% PER MONTH WHICH IS AN ANNUAL PERCENTAGE RATE OF 18% WILL BE CHARGED ON ACCOUNTS PAST DUE.

Signature: _____ Name: _____ Title: _____ Date: _____



Proposal

Interior Environments - Novi
48700 Grand River Ave
Novi, MI 48374
Phone: (248) 213-3010

Order Number	12145
Date	01/05/2023
Customer PO No	
Customer Name	Livonia Public Schools
Salesperson	Bari Pfeiffer
Terms	NET 30
Page	4 of 6

Balco Interiors LLC and IE Connect LLC - d/b/a INTERIOR ENVIRONMENTS TERMS AND CONDITIONS OF SALE

1. PROPOSALS AND ORDERS

- A. **TERM:** All prices quoted by Interior Environments ("Seller") are valid for 30 days from date of proposal.
- B. **OFFER AND ACCEPTANCE:** All orders for the purchase of goods and services from Seller require a proposal prepared by Seller which has been approved and signed by an authorized signatory of Buyer. Seller's proposal shall constitute an offer and Buyer's approval of the proposal shall constitute acceptance of that offer. If Buyer submits a purchase order before Seller issues a proposal, Seller's proposal shall constitute a counteroffer and Buyer's approval of the Seller's proposal shall constitute acceptance of that counter offer without any additional terms or conditions.
- C. **AGREEMENT:** Following the offer and acceptance described above and Seller's payment as provided in paragraph 2 below, an "Agreement" between the parties shall be deemed to have been formed with such Agreement comprised solely of Seller's proposal together with these Terms and Conditions of Sale. The Agreement shall be deemed to supersede any prior written or oral agreements and any different or conflicting terms in any quote, invoice, Buyer purchase order, shipper or any other document. For the avoidance of doubt, any different, additional or conflicting terms provided on any ancillary Buyer document(s) are expressly rejected by Seller.
- D. **MODIFICATIONS/CHANGES/CANCELLATIONS:** Any requested modification to an Agreement is subject to the approval of Seller and the manufacturer or supplier of the goods ordered. Buyer will pay any and all additional charges resulting from order modifications, cancellations, and changes. Express Ship Orders cannot be changed or cancelled. All goods are custom manufactured to customer specifications and, therefore, cannot be returned. Restocking programs are not available. Any modifications of an Agreement must be made via a signed and dated revised proposal.

2. CREDIT APPROVAL AND DEPOSITS

All orders are subject to credit approval. A deposit of 50% is required on all orders greater than \$5,000.00. No interest shall accrue on such deposits. Orders less than \$5,000.00 must be paid in full. The Agreement is deemed entered upon such payment by Buyer.

3. OWNERSHIP AND RISK OF LOSS

Transfer of title to the goods as between Seller and Buyer shall be deemed to have occurred when the Agreement is entered, and thereafter Buyer shall insure against risk of loss. If the goods are first received on behalf of Buyer by Seller, such goods shall be considered held by Seller subject to bailment for the sole benefit of Buyer.

4. PAYMENT

- A. **TIMING:** Any remaining balance on goods purchased under this Agreement and any related installation or other services will be invoiced upon delivery of the goods to the job site or, if installed by Seller, following substantial completion. Direct shipments from manufacturers will be invoiced upon shipment from the manufacturer. Any goods being held at Buyer's request, due to delays or otherwise, will be invoiced for product only upon Seller's receipt of same with separate invoicing for installation or other related services upon substantial completion.
- B. **PAYMENT TERMS:** Seller has the right to increase its prices at any time upon notice to Buyer to reflect any and all unusual or unforeseen increases in Seller cost, provided that any such increase shall be limited to the increase actually incurred by Seller. Buyer will not offset or recoup any claim against amounts due Seller. All invoices are due on the date noted on the related invoice. A monthly service charge of 1.5% (18% A.P.R.) will be assessed on all unpaid balances, including accrued but unpaid monthly service charges, after the invoice due date. A service charge of three percent (3%) of the invoice amount will be added to all invoices paid by credit card.
- C. **FREIGHT:** Buyer is solely responsible for any applicable freight and handling charges, including tariffs, for delivery from the manufacturer to Seller and is FOB origin. If not included in the proposal, such charges are not included in a price quotation and will be invoiced to Buyer separately after the Seller is invoiced by the carrier or manufacturer.
- D. **TAXES:** Buyer is solely responsible for any applicable sales, use, excise, or other taxes. If not included in the proposal, applicable taxes will be invoiced separately. If Buyer possesses tax-exempt status, a certificate of resale, or tax exemption is to be provided prior to order placement.
- E. **DELAYS:** If Buyer is unable or unwilling to receive goods at the prescribed shipping site on the mutually agreed delivery date any goods



Proposal

Interior Environments - Novi
48700 Grand River Ave
Novi, MI 48374
Phone: (248) 213-3010

Order Number	12145
Date	01/05/2023
Customer PO No	
Customer Name	Livonia Public Schools
Salesperson	Bari Pfeiffer
Terms	NET 30
Page	5 of 6

thereafter stored by Seller will be at Buyer's expense until such time as Buyer is able to accept delivery. Seller shall have no obligation or liability to Buyer whatsoever for failure to ship goods by a particular date.

5. DELIVERY AND INSTALLATION

- A. **DELIVERY AND INSTALLATION:** Any contracted delivery and installation will be made during Seller's normal business hours of 7:00 a.m. to 3:30 p.m., Monday through Friday. Overtime delivery or installation performed at the Buyer's request will be subject to labor rates reflecting time-and-a-half for weekdays and double time for weekends and holidays. If applicable trade regulations require employing union tradesmen to complete the installation or delivery, any additional incremental costs will be invoiced to and paid by the Buyer. Seller shall not be liable for failure or delay in installation due to the installation site not being ready for installation. Any shipping, delivery, and performance dates are estimates only, and time is not of the essence. Seller may ship or direct shipments of all the goods at one time or in portions from time to time. Seller has the right, but not the obligation, to determine the method of shipment and routing of the goods, unless otherwise stated in Seller's delivery and installation proposal or acknowledgment.
- B. **SELLER'S RESPONSIBILITIES:** Unless received by Buyer or Buyer's agent directly, Seller will receive, inspect, stage, and if contracted, install Buyer's goods. All furnishings will be left clean and in working order. Carton and packing materials will be removed to the Buyer's waste disposal containers, and the premises will be left broom clean. At Seller's option, Seller may direct shipments directly to the job site.
- C. **BUYER'S ACCEPTANCE:** Buyer agrees to have an agent on the premises at the agreed upon time to accept goods, deliveries, installation, and completed work. All goods and services shall be considered accepted after Buyer or his agent has signed an acknowledgement document(s). All claims or exceptions must be made in writing the date the work is substantially complete. Notwithstanding the foregoing, if Buyer or Buyer's agent is unavailable or unwilling to sign acknowledgment document(s), Buyer shall be deemed to have accepted the goods and services "as is" or as otherwise noted by Seller on the acknowledgement document.
- D. **DROP SHIPMENTS:** In case of drop shipments where goods are delivered without installation, Buyer will receive, inspect, and install ordered goods. Buyer is also responsible for filing necessary freight claims in the event of damage. Buyer shall have no claims against Seller due to damage and may not withhold payment on account thereof.
- E. **CONDITION OF JOB SITE:** Buyer's job site shall be clean, clear of all obstructions, and free of debris prior to any Seller installation. Charges will be assessed to the Buyer for excessive handling, storage and transportation incurred because of site conditions, activity of other trades, or other reasons not specifically identified in the price quotation, at a standard hourly rate, or at actual charges plus fees, if labor is performed by a third party.
- F. **JOB SITE SERVICES:** Buyer will furnish electrical current, heating, lighting, trash disposal containers, hoisting and/or elevator services, and suitable unobstructed dock space and staging areas at the job site without charge to Seller if Seller is to provide installation. If Seller is required to remove or handle existing furniture, the additional cost of moving and transporting shall be billed to the Buyer on an hourly basis. Once installation has begun, Buyer agrees to assume any expense incurred by Seller due to changes made at the Buyer's request or for any reason beyond Seller's reasonable commercial control.
- G. **ELECTRICAL INSTALLATION:** A licensed electrician may be required to install electrical product including outlets, task lights, and hook-ups to base building power. If Seller determines that an electrician is required, Buyer will be responsible for contracting and paying the electrician.
- H. **PROTECTION OF DELIVERED GOODS:** Buyer is responsible for security and safekeeping of goods after delivery to Buyer's site, or into storage negotiated by Buyer if the job site is not ready on an agreed upon delivery date, and Buyer shall assume any risk of damage or loss thereof.
- I. **CONCEALED DAMAGED GOODS:** Buyer is required to report all concealed or damage packaged goods within seven (7) business days or receipt. In addition, Buyer is required to report all damage goods revealed upon unpackaging within seven (7) days of the same. Likewise, Buyer is required to and must send pictures of damaged goods, packages and labels to initiate any available warranty claim(s). Failure to report damages within the required reporting period with the required information may negate any warranty claims and Buyer shall accept responsibility for any and all costs associated with replacement or repairs of damaged goods.

6. ADDITIONAL TERMS

- A. **DISCLAIMER OF WARRANTIES: BUYER AGREES THAT THE GOODS ARE OF THE SIZE AND DESIGN SELECTED BY BUYER AND THAT BUYER IS SATISFIED THAT SAME IS SUITABLE FOR BUYER'S PURPOSES. SELLER HAS MADE NO REPRESENTATION**



Proposal

Interior Environments - Novi
48700 Grand River Ave
Novi, MI 48374
Phone: (248) 213-3010

Order Number	12145
Date	01/05/2023
Customer PO No	
Customer Name	Livonia Public Schools
Salesperson	Bari Pfeiffer
Terms	NET 30
Page	6 of 6

OR WARRANTY AS TO ANY MATTER WHATSOEVER. SELLER DISCLAIMS AND BUYER EXPRESSLY WAIVES AS TO SELLER, ALL WARRANTIES WITH RESPECT TO THE GOODS, INCLUDING BUT NOT LIMITED TO ALL EXPRESS OR IMPLIED WARRANTIES OF MERCHANTABILITY AND FITNESS FOR A PARTICULAR PURPOSE, QUALITY, CAPACITY, OR WORKMANSHIP. NOTHING CONTAINED HEREIN SHALL DIMINISH THE RIGHT OF BUYER TO EXERCISE ALL RIGHTS AND REMEDIES AGAINST THE MANUFACTURER OF THE GOODS FOR MANUFACTURER WARRANTIES. IN NO EVENT SHALL SELLER BE LIABLE UNDER ANY THEORY AT LAW OR EQUITY FOR ANY LOSS OF USE, REVENUE, ANTICIPATED PROFIT OR SPECIAL, INDIRECT, INCIDENTAL OR CONSEQUENTIAL DAMAGES ARISING OUT OF OR RELATED TO THE DESIGN AND USE OF THE GOODS. SELLER SHALL ADVISE BUYER OF ALL RELATED MANUFACTURERS' WARRANTIES UPON BUYER'S REQUEST.

- B. **RESALE:** On any resale of the goods, Buyer shall contractually limit its buyer's warranty against both Buyer and Seller to the same extent that Paragraph 6(A) above limits the warranty offered by Seller.
- C. **ACTS BEYOND REASONABLE CONTROL:** Seller shall not be liable for any delay or failure to deliver any or all of the goods caused by installation site delays, labor disputes, strikes, acts of God, or other delays beyond the reasonable control of Seller.
- D. **ASSIGNMENT:** Buyer shall not assign its rights or obligations under this Agreement without the prior written consent of Seller.
- E. **INDEMNIFICATION:** Buyer shall indemnify, defend, and hold harmless Seller with respect to all damages, losses, claims, and expenses, including, without limitation, consequential and incidental damages and reasonable attorney fees arising from or related to : i) Buyer's breach of any of Buyer's obligations under this Agreement and from; ii) Seller's interior design, project management, delivery, installation, or any other services except when caused by Seller's gross negligence or willful misconduct.
- F. **DEFAULT:** If Buyer fails to pay any amount herein provided within ten (10) days after the same is due and payable, or if Buyer fails to observe, keep, or perform any other provision of this Agreement, then Seller shall have the right to exercise any one or more of the following remedies without prejudice to such remedies as may otherwise exist at law or in equity: i) to declare the entire amount due hereunder immediately due and payable without notice or demand to Buyer; ii) to sue for and recover all payments, then accrued or thereafter accruing; iii) to take possession of the goods provided hereunder, without demand or notice wherever located, without any court order or other process of law. Buyer hereby grants free and full access to the premises and hereby waives any and all damages occasioned by such taking of possession.
- G. **NO WAIVER:** Seller's waiver of any right on one occasion shall not be a waiver of any future exercise of that right.
- H. **TIME FOR BRINGING ACTION:** Any action that Buyer brings against Seller that arises out of or relates to the goods and services provided by Seller to Buyer must be brought by Buyer within one year after the cause of action occurs.
- I. **LAW:** The Agreement shall be deemed entered into, and performed in substantial part, in Oakland County, Michigan. The Agreement shall be governed by and construed in accordance with the laws of the State of Michigan, without regard to its conflict of law provisions. The parties hereto agree to submit to the exclusive personal jurisdiction of the state or federal courts serving Oakland County, Michigan for the resolution of any claim or cause of action that arises from or related to this Agreement or the goods or services provided by Seller.

FAMILIAL RELATIONSHIP DISCLOSURE STATEMENT

As required by Public Act 232 of 2004, all bids shall be accompanied by a sworn and notarized statement disclosing any familial relationship that exists between the owner or any employee of the bidder and any member of the Northville Public Schools Board of Education or the Superintendent of Schools. The Board of Education shall not accept a bid that does not include this sworn and notarized disclosure statement.

The undersigned, the owner or authorized officer of Interior Environments (the "Bidder"), pursuant to the familial disclosure requirement provided in the Livonia Public Schools advertisement for construction bids, hereby represent and warrant, except as provided below, that no familial relationships exist between the owner(s) or any employee of the company and any member of the Livonia Public Schools Board of Education or the Superintendent of Schools. If such a relationship exists, please explain:

Attach additional pages if necessary

By: Basi Patel (Bidder Signature)
Title: Account Manager (type or print)
Date: 12/21/22

Subscribed and Sworn to Before Me:

This 21st day of December, 2022 A.D., in and for the
County of Oakland, Michigan.

My Commission expires 4/22/2026.

[Signature]
Signature of Notary

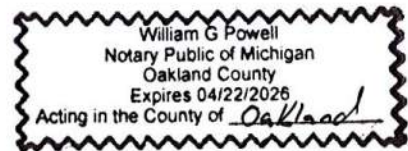

NON-COLLUSION AFFIDAVIT

STATE OF MICHIGAN)
)
WAYNE COUNTY) ss:

The undersigned bidder or agent, being duly sworn on oath, says that he/she has not, nor has any other member, representative, or agent of the firm, company, corporation or partnership represented by him/her, entered into any combination, collusion or agreement with any person relative to the price to be bid by anyone at such letting nor to prevent any person from bidding nor to induce anyone to refrain from bidding, and that this bid is made without reference to any other bid and without any agreement, understanding or combination with any other person in reference to such bidding.

He/she further says that no person or persons, firms, or corporation has, have or will receive directly or indirectly, any rebate, gift, fee, commission or thing of value on account of such sale.

Interior Environments

Bidder (Firm)
Bari Patel

Signature of Bidder or Agent

Subscribed and sworn to before me this 21st day of December, 2022.

My commission expires: 04/22/2026

County of residence: Oakland

[Signature]

Notary Public Signature

Seal

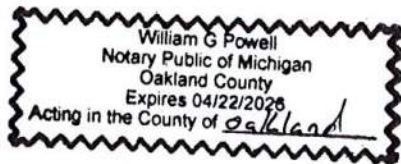

CERTIFICATION OF COMPLIANCE – IRAN ECONOMIC SANCTIONS ACT
Michigan Public Act No. 517 of 2012

The undersigned, the owner, or authorized officer of the below-named company (the "Company"), pursuant to the compliance certification requirement provided in the Livonia Public Schools Request For Proposal (the "RFP"), hereby certifies, represents, and warrants that the Company (which includes its officers, directors and employees) is not an "Iran Linked Business" within the meaning of the Iran Economic Sanctions Act, Michigan Public Act No. 517 of 2012 (the "Act"), and that in the event the Company is awarded a contract by the Livonia Public Schools Board of Education as a result of the aforementioned RFP, the Company is not and will not become an "Iran Linked Business" at any time during the course of performing any services under the contract.

The Company further acknowledges that any person who is found to have submitted a false certification is responsible for a civil penalty of not more than \$250,000.00 or two (2) times the amount of the contract or proposed contract for which the false certification was made, whichever is greater, the cost of the Livonia Public Schools' investigation, and reasonable attorney fees, in addition to the fine. Moreover, any person who submitted a false certification shall be ineligible to bid on a request for proposal for three (3) years from the date that it is determined that the person has submitted the false certification.

Interior Environments

Name of Company

Bari Pfeiffer, Account Manager

Name and Title of Authorized Representative

Bari Pfeiffer
Signature

12-21-22

Date

END OF SECTION

Wenger Corporation
 555 Park Drive
 Owatonna, MN 55060-4940
 United States



Phone: 507-455-4100
 Fax: 507-455-4258

Quote Number: 3262783

Stagetek Audience Seating OMNIA updated
 12.12.2022

QUOTE

Date: 12/12/2022
 Page: 1 of 3
 Cust #: 00137299

<p>Quote To:</p> <p>Livonia Career & Technical Ctr 8985 Newburgh Rd Livonia MI 48150-3497 United States</p> <p>Phone: Fax: E-Mail:</p>	<p>Date: 12/12/2022 Expires: 2/24/2023 Reference: Terms: Net 30 Days Created By: Christy Mullerleile</p> <p>Salesperson: Theresa Bartok Phone: +1 (507) 774-8527 E-Mail: Theresa.Bartok@wengercorp.com</p>
---	--

Quote Comments:

Since the pandemic, significant supply chain issues have been creating disruption across many industries globally. At Wenger Corporation, our purchasing team is working with our suppliers to mitigate the impact of the disruptions.

Unfortunately, we are facing shortages in key areas such as steel, plastic and wood resulting in delays in meeting our customers' orders/timelines.

Freight quoted is for a one time shipment. As a result, once orders are placed, delivery dates may change.

****PLEASE NOTE: Customer requested split shipments will result in an additional freight charge.****

We apologize for any inconvenience this may cause. We value your business and thank you for your patience during these unusual circumstances.

Customer to verify all items on this quote before placing order

** Wenger is an approved vendor for Region 4 ESC/OMNIA Partners, Public Sector. All items on this quotation are available through Contract #R191204. This contract is in effect through 10/31/2023.*

Line	PartNum/Description	Qty	Net Price	Ext. Price
1.00	280A200.112 StageTek Rectangular Deck Cracked Ice 3'x8',Center Brace	8 EA	\$774.00	\$6,192.00
2.00	280B100.136 StageTek Fixed Leg 32" Elevation	16 EA	\$18.00	\$288.00
3.00	280B100.123 StageTek Fixed Leg 16" Elevation	32 EA	\$12.00	\$384.00
4.00	281A340 STAGETEK,CONNECT,2 LEG,RECT	14 EA	\$28.00	\$392.00
5.00	281A600 LEG STORAGE CLIP,4 PK	12 EA	\$16.00	\$192.00

USD

Wenger Corporation
 555 Park Drive
 Owatonna, MN 55060-4940
 United States



Phone: 507-455-4100
 Fax: 507-455-4258

Quote Number: 3262783

Stagetek Audience Seating OMNIA updated
 12.12.2022

QUOTE

Date: 12/12/2022
 Page: 2 of 3
 Cust #: 00137299

6.00	281C404.127 StageTek Standard Guardrail 8'	4 EA	\$266.00	\$1,064.00
7.00	281C404.118 StageTek Standard Guardrail 3'	2 EA	\$194.00	\$388.00
8.00	113K001 Staging Universal Deck & Rail Cart	3 EA	\$672.00	\$2,016.00
9.00	281A304 LEG STRAP,45",2 PK	8 EA	\$0.00	\$0.00
10.00	281A100 StageTek 2-Step Stairway 16/24" With Rail	1 EA	\$475.00	\$475.00
11.00	Freight Freight Services	1 EA	\$2,216.19	\$2,216.19
12.00	Install Installation Services	1 EA	\$1,866.94	\$1,866.94

INSTALLATION WITH INSIDE DELIVERY

*******MAIN FLOOR INSTALL ONLY*******

This pricing includes complete delivery and installation, which includes unloading, assembling and removal of debris by Wenger-trained technicians, at non-prevailing, non-union wage rates, to 1st floor locations.

2nd floor or greater may incur additional fees. Check with your representative for further details.

NOTE: ** At time of order please provide COVID protocol requirements and any campus safety/security requirements and directions for compliance. ******

Notwithstanding anything to the contrary in this agreement, Wenger shall not be liable for delay or non-performance caused by any of the following circumstances when beyond its control: acts of God, explosions, riots, labor disputes (provided Wenger has exercised reasonable commercial efforts to avoid it), failures of utilities or public services, civil unrest, foreign or domestic governmental regulation or order, public health emergencies, natural disasters, cyber-attacks, wars, acts of foreign enemies, sabotage, or terrorism, including sub-supplier delays caused by any of the above provided the same are not caused or contributed to by the negligence or fault of Wenger ("Force Majeure").

If you are a tax-exempt organization and quote includes tax, please send a copy of your tax-exempt certificate and we will remove the sales tax. Thank you

Note: The pricing shown above includes complete delivery, unloading, assembly, installation, and removal of debris by Wenger trained technicians.

FAMILIAL RELATIONSHIP DISCLOSURE STATEMENT

As required by Public Act 232 of 2004, all bids shall be accompanied by a sworn and notarized statement disclosing any familial relationship that exists between the owner or any employee of the bidder and any member of the Northville Public Schools Board of Education or the Superintendent of Schools. The Board of Education shall not accept a bid that does not include this sworn and notarized disclosure statement.

The undersigned, the owner or authorized officer of Wenger Corporation (the "Bidder"), pursuant to the familial disclosure requirement provided in the Livonia Public Schools advertisement for construction bids, hereby represent and warrant, except as provided below, that no familial relationships exist between the owner(s) or any employee of the company and any member of the Livonia Public Schools Board of Education or the Superintendent of Schools. If such a relationship exists, please explain:

None

Attach additional pages if necessary

By: _____ (Bidder Signature)

Title: Theresa Bartok, Senior Acquisitions Sales Representative (type or print)

Date: December 21, 2022

Subscribed and Sworn to Before Me:

This 21st day of December, 2022 A.D., in and for the

County of Steele, ~~Michigan~~ Minnesota

My Commission expires January 31, 2025.

Lola Ann McDermott

Signature of Notary

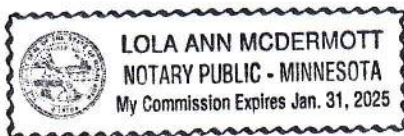

NON-COLLUSION AFFIDAVIT

Minnesota

STATE OF ~~MICHIGAN~~)
Steele) ss:
~~WAYNE~~ COUNTY)

The undersigned bidder or agent, being duly sworn on oath, says that he/she has not, nor has any other member, representative, or agent of the firm, company, corporation or partnership represented by him/her, entered into any combination, collusion or agreement with any person relative to the price to be bid by anyone at such letting nor to prevent any person from bidding nor to induce anyone to refrain from bidding, and that this bid is made without reference to any other bid and without any agreement, understanding or combination with any other person in reference to such bidding.

He/she further says that no person or persons, firms, or corporation has, have or will receive directly or indirectly, any rebate, gift, fee, commission or thing of value on account of such sale.

Wenger Corporation
Bidder (Firm)

Theresa Bartok
Signature of Bidder or Agent
Theresa Bartok, Senior Acquisitions Sales Representative

Subscribed and sworn to before me this 21st day of December, 2022.

My commission expires: January 31, 2025

County of residence: Steele

Lola Ann McDermott
Notary Public Signature

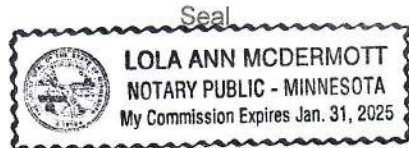

CERTIFICATION OF COMPLIANCE – IRAN ECONOMIC SANCTIONS ACT
Michigan Public Act No. 517 of 2012

The undersigned, the owner, or authorized officer of the below-named company (the "Company"), pursuant to the compliance certification requirement provided in the Livonia Public Schools Request For Proposal (the "RFP"), hereby certifies, represents, and warrants that the Company (which includes its officers, directors and employees) is not an "Iran Linked Business" within the meaning of the Iran Economic Sanctions Act, Michigan Public Act No. 517 of 2012 (the "Act"), and that in the event the Company is awarded a contract by the Livonia Public Schools Board of Education as a result of the aforementioned RFP, the Company is not and will not become an "Iran Linked Business" at any time during the course of performing any services under the contract.

The Company further acknowledges that any person who is found to have submitted a false certification is responsible for a civil penalty of not more than \$250,000.00 or two (2) times the amount of the contract or proposed contract for which the false certification was made, whichever is greater, the cost of the Livonia Public Schools' investigation, and reasonable attorney fees, in addition to the fine. Moreover, any person who submitted a false certification shall be ineligible to bid on a request for proposal for three (3) years from the date that it is determined that the person has submitted the false certification.

Wenger Corporation

Name of Company

Theresa Bartok, Senior Acquisitions Sales Representative

Name and Title of Authorized Representative

Theresa Bartok

Signature

December 21, 2022

Date

END OF SECTION

Wenger Corporation
555 Park Drive
Owatonna, MN 55060-4940
United States



Phone: 507-455-4100
Fax: 507-455-4258

Quote Number: 3262783

Stagetek Audience Seating OMNIA updated
12.12.2022

QUOTE

Date: 12/12/2022
Page: 3 of 3
Cust #: 00137299

Lines Total	\$15,474.13
Total Taxes	\$683.46

Quote Total	\$16,157.59
--------------------	--------------------



MUSIC EDUCATION AND PERFORMING ARTS

Owatonna Office: Phone 800.4WENGER (493-6437) Worldwide +1.507.455.4100 | Parts & Service 800.887.7145 | wengercorp.com | 555 Park Drive, PO Box 448 | Owatonna | MN 55060-0448

Syracuse Office: Phone 800.836.1885 Worldwide +1.315.451.3440 | jrclancy.com | 7041 Interstate Island Road | Syracuse | NY 13209-9713

ATHLETICS Phone 800.493.6437 | email gearboss@wengercorp.com | gearboss.com | 555 Park Drive, PO Box 448 | Owatonna | MN 55060-0448

**LIVONIA PUBLIC SCHOOLS
BOARD OF EDUCATION MEETING
January 30, 2023**

TOPIC: Approval of IT Bid Results for LCTC & Robotics - 2021 Bond

RECOMMENDATION:

Move that the Board of Education of the Livonia Public Schools School District accept the recommendation from the Owner's Representative, Plante Moran Cresa, to approve Digital Age Technology, Davison, Michigan, as the technology contractor for the renovation of LCTC and the new robotics center, in the amount of \$113,177, which includes contingency, and authorize the Superintendent or her designee to negotiate and execute final contracts with the recommended contractor.

RATIONALE:

The technology contractor will be responsible for technology projects for the LCTC renovation and the Robotics addition. The scope of work includes providing voice, audio/video, and data systems for this building.

BUDGETARY INFORMATION:

2021 Bond

RESOURCE PERSONNEL:

Phillip Francis, Assistant Superintendent of District Services

EXHIBITS:

Attached

PF/ko

January 16, 2023

Mr. Phillip Francis
Asst. Superintendent of District Services
Livonia Public Schools
15125 Farmington Road
Livonia, MI 48154

RE: 2021 Bond Program
Contract Award Recommendation for Technology Contractor Bids
LCTC/Robotics Addition & Renovations

Dear Mr. Francis:

This letter transmits an update from Plante Moran Cresa (PMC) as it relates to the assignment to assist and advise Livonia Public Schools (LPS) in its selection of a Technology Contractor for the Projects listed above. This update represents the mutual efforts of PMC, IDS and LPS administration and staff (the Bond Team) to present a framework in order to identify, evaluate and recommend Vendors for these Projects.

On October 31, 2022, Bid Documents were formally issued and made available. An advertisement for bids was published in a local newspaper and also posted to the required State of Michigan websites.

On November 21, 2022, two (2) bid proposals were received and publicly opened. Over the next few days, the bid proposals were reviewed to determine the budget implications. Interviews were held with the bidders on November 30, 2022. The scope of work, project schedule, phasing, manpower requirements, and other particulars regarding the work were reviewed and discussed.

Upon completion of the interviews, and after subsequent clarifications and discussions, the Bond Team is recommending **Digital Age Technologies, Inc.** for contract award as detailed in IDS' recommendation letter dated December 2, 2022.

Including the Base Bid Amount of \$105,177 and a contingency in the amount of \$8,000, the total Project award recommendation equals **\$113,177.00**.

The costs for this work will be detailed in the Contract, which was included in this RFP, pending final review and approval of terms by district legal counsel.

The Project Team is available at the Board's convenience to answer any questions regarding bidding, the proposals, interview process, or the recommendations of the Bond Team. Please direct all questions through me via email at brian.weber@plantemoran.com.

Mr. Phillip Francis
Livonia Public Schools

January 16, 2023
Page 2

Sincerely,

PLANTE MORAN CRESA



Brian Weber
Vice President

Enclosures: Summary of Costs
 IDS Recommendation Letter
 Vendor Proposal



LCTC/ROBOTICS - TECHNOLOGY CONTRACTOR
BUDGET SUMMARY

	Base Cost		
Buildings	Budget	Actual	Variance
LCTC/Robotics	\$ 200,000	\$ 105,177	\$ 94,823
Totals	\$ 200,000	\$ 105,177	\$ 94,823

	Contingency		
Buildings	Budget	Actual	Variance
LCTC/Robotics	\$ 20,000	\$ 8,000	\$ 12,000
Totals	\$ 20,000	\$ 8,000	\$ 12,000

	Total Project Costs		
Buildings	Budget	Actual	Variance
LCTC/Robotics	\$ 220,000	\$ 113,177	\$ 106,823
Totals	\$ 220,000	\$ 113,177	\$ 106,823

December 2, 2022

Mr. Phillip Francis
 Assistant Superintendent of district Services
 Livonia Public Schools
 15125 Farmington Road
 Livonia, MI 48154

Project Name: Livonia Public Schools
 LCTC Renovations and Robotics Addition – Technology
 Livonia, Michigan

IDS Project No.: 21191-1000 BP 02

Dear Mr. Francis:

Bid specifications and drawings for the technology requirements of the LCTC Renovations and Robotics Addition project were issued on October 31, 2022. The bid package scope consists of providing relocation of existing voice, audio/video, and data systems for the renovations of the existing building and the addition of new technologies for the Robotics Addition.

Representatives from three (3) companies attended the pre-bid conference on November 7, 2022. The pre-bid conference was not mandatory.

Two (2) bids were received on November 21, 2022, as follows:

Bidder	Bid Bond	Familial Disclosure	Iran Sanctions Affidavit	Criminal Background Affidavit	Base Bid
Digital Age Technologies, Inc.	Yes	Yes	Yes	Yes	\$105,177.00
AmComm Telecommunications	Yes	Yes	Yes	Yes	\$133,709.00

The bidders included the required Bid Bond, Familial Disclosure, Affidavit of Compliance and Criminal Background Affidavit with their bid submissions.

The technology team has reviewed the bids and conducted a post-bid interview with the low apparent bidder, Digital Age Technologies, on November 30, 2022. The bid was determined to be complete and compliant with the requirements of the bidding documents. The bill of materials pricing was determined to be in line with current industry trends and historical competitive bidding pricing models for projects of a similar size and scope.

IDS recommends the award of the LCTC Renovations and Robotics Addition - Technology to the lowest qualified bidder, **Digital Age Technologies, Inc., in the amount of \$105,177.00.**

In addition to the award amount, IDS is also recommending a construction contingency be established in the amount of \$8,000.00.

Sincerely,

Integrated Design Solutions, LLC

Scott Smith
 Senior Associate

Rock Morey
 Project Manager

5211 cascade road se, ste. 300
 grand rapids, mi 49546

1441 w. long lake road, ste. 200
 troy, mi 48098

248-823-2100 www.ids-michigan.com

Mr. Tim Klan
IDS Project No. 21191-1000
April 12, 2022
Page 2

ec: T. Klan, LPS
B. Weber, PMC
File

**LIVONIA PUBLIC SCHOOLS
BOARD OF EDUCATION MEETING
January 30, 2023**

TOPIC: Approval of IT Bid Results for 2023 Renovations - 2021 Bond

RECOMMENDATION:

Move that the Board of Education of the Livonia Public Schools School District accept the recommendation from the Owner's Representative, Plante Moran Cresa, to approve Phase 2 of the Technology Contractor bid from AMcomm Telecommunications, Brighton, Michigan, in the amount of \$240,000, which includes contingency, and authorize the Superintendent or her designee to negotiate and execute final contracts with the recommended contractor.

RATIONALE:

The technology contractor will be responsible for Phase 2 Bond technology projects at Cleveland Elementary, Rosedale Elementary, Riley Upper Elementary, Frost Middle School, and Franklin High School in the summer of 2023. The majority of the technology work will be done in the LMC renovations. The scope includes providing voice, audio/video, and data systems for the LMCs in the listed schools, including the new Idea Factories.

BUDGETARY INFORMATION:

2021 Bond Fund

RESOURCE PERSONNEL:

Phillip Francis, Assistant Superintendent of District Services

EXHIBITS:

Attached

PF/ko



Real Estate Consultants

Plante Moran Cresa, LLC
3000 Town Center, Suite 100
Southfield, MI 48075

Tel: 248.223.3500 | Fax: 248.223.3150

pmcresa.com

January 17, 2023

Mr. Phillip Francis
Asst. Superintendent of District Services
Livonia Public Schools
15125 Farmington Road
Livonia, MI 48154

RE: 2021 Bond Program
Contract Award Recommendation for Technology Contractor Bids
Cleveland ES / Rosedale ES / Riley UES / Frost MS / Franklin HS

Dear Mr. Francis:

This letter transmits an update from Plante Moran Cresa (PMC) as it relates to the assignment to assist and advise Livonia Public Schools (LPS) in its selection of a Technology Contractor for the Projects listed above. This update represents the mutual efforts of PMC, IDS and LPS administration and staff (the Bond Team) to present a framework in order to identify, evaluate and recommend Vendors for these Projects.

On December 19, 2022, Bid Documents were formally issued and made available. An advertisement for bids was published in a local newspaper and also posted to the required State of Michigan websites.

On January 9, 2023, three (3) bid proposals were received and publicly opened. Over the next few days, the bid proposals were reviewed to determine the budget implications. An interview was held with the bidders on January 12, 2023. The scope of work, project schedule, phasing, manpower requirements, and other particulars regarding the work were reviewed and discussed.

Upon completion of the interviews, and after subsequent clarifications and discussions, the Bond Team is recommending **AMcomm Telecommunications** as the lowest responsible bidder for contract award as detailed in IDS' recommendation letter dated January 13, 2023.

Including the base bid amount of \$220,000.00 and a contingency in the amount of \$20,000, the total Project award recommendation equals **\$240,000.00**.

AMcomm Telecommunications	\$	220,000.00
Contingency	\$	20,000.00
Total	\$	240,000.00

The costs for this work will be detailed in the Contract, which was included in this RFP, pending final review and approval of terms by district legal counsel.

The Project Team is available at the Board's convenience to answer any questions regarding bidding, the proposals, interview process, or the recommendations of the Bond Team. Please direct all questions through me via email at brian.weber@plantemorán.com.

Sincerely,

PLANTE MORAN CRESA



Brian Weber
Vice President

Enclosures: Summary of Costs
 IDS Recommendation Letter



TECHNOLOGY - 2023 CONSTRUCTION
BUDGET SUMMARY

	Base Cost		
Buildings	Budget	Actual	Variance
Listed Below	\$ 230,000	\$ 220,000	\$ 10,000
Totals	\$ 230,000	\$ 220,000	\$ 10,000

	Contingency		
Buildings	Budget	Actual	Variance
Listed Below	\$ 20,000	\$ 20,000	\$ -
Totals	\$ 20,000	\$ 20,000	\$ -

	Total Project Costs		
Buildings	Budget	Actual	Variance
Listed Below	\$ 250,000	\$ 240,000	\$ 10,000
Totals	\$ 250,000	\$ 240,000	\$ 10,000

Includes the following sites:

- Rosedale Elementary
- Cleveland Elementary
- Riley Upper Elementary
- Frost Middle
- Franklin High

January 13, 2023

Mr. Phillip Francis
 Assistant Superintendent of district Services
 Livonia Public Schools
 15125 Farmington Road
 Livonia, MI 48154

Project Name: Livonia Public Schools
 Media Center Renovations – Technology
 Livonia, Michigan

IDS Project No.: 21191-1000 BP 04

Dear Mr. Francis:

Bid specifications and drawings for the technology requirements of the Phase II Media Center Renovations – Technology project were issued on December 19, 2022. The bid package scope consists of providing relocation of existing voice, audio/video, and data systems for the renovations of the existing building media centers and kitchens.

Representatives from three (3) companies attended the pre-bid conference on December 22, 2022. The pre-bid conference was not mandatory.

Three (3) bids were received on November January 9, 2023 as follows:

Bidder	Bid Bond	Familial Disclosure	Iran Sanctions Affidavit	Criminal Background Affidavit	Base Bid
Digital Age Technologies, Inc.	Yes	Yes	Yes	Yes	Incomplete
Sound Planning Communications	Yes	Yes	Yes	Yes	\$151,137.22
AMcomm Telecommunications	Yes	Yes	Yes	Yes	\$220,000.00

The bidders included the required Bid Bond, Familial Disclosure, Affidavit of Compliance and Criminal Background Affidavit with their bid submissions.

The technology team has reviewed the bids and conducted post-bid interviews with the bidders providing a complete bid response on January 12, 2023. The bid response from Digital Age Technologies did not enumerate their total base bid in either numbers or words and was rejected. The bid submitted by Sound Planning Communications was missing enumeration and pricing for data cabling and was withdrawn by the bidder. The bid By AMcomm Telecommunications was determined to be complete and compliant with the requirements of the bidding documents. The bill of materials pricing was determined to be in line with current industry trends and historical competitive bidding pricing models for projects of a similar size and scope, and the bidder agreed to extended unit pricing for an additional year beyond the substantial completion date of this project for future work.

IDS recommends the award of the Media Center Renovations – Technology Bid Pack 04 to the lowest qualified bidder, AMcomm Telecommunications, in the amount of \$220,000.00.

In addition to the award amount, IDS is also recommending a construction contingency be established in the amount of \$20,000.00.

Sincerely,

Rock Morey
 Project Manager

ec: T. Klan, LPS
 B. Weber, PMC
 File

**LIVONIA PUBLIC SCHOOLS
BOARD OF EDUCATION MEETING
January 30, 2023**

TOPIC: **Approval of Bid Results for Security Cameras**

RECOMMENDATION:

Move that the Board of Education of the Livonia Public Schools School District accept the recommendation from the Owner’s Representative, Plante Moran Cresa, to approve the purchase and installation of security cameras, including licensing for ten years, from Sentinel Technologies, Chicago, Illinois, in the amount of \$1,890,542.66, which includes contingency.

RATIONALE:

This purchase will replace security cameras and provide additional security camera coverage, both interior and exterior, to all buildings in the District and allow for cloud storage of any saved footage. This is a planned Bond project.

BUDGETARY INFORMATION:

State of Michigan Section 97 Grant and 2021 Bond

RESOURCE PERSONNEL:

Phillip Francis, Assistant Superintendent of District Services

EXHIBITS:

Attached

PF/ko

January 19, 2023

Mr. Phillip Francis
Asst. Superintendent of District Services
Livonia Public Schools
15125 Farmington Road
Livonia, MI 48154

RE: 2021 Bond Program
Contract Award Recommendation for Technology Contractor Bids
Security Cameras – District Wide

Dear Mr. Francis:

This letter transmits an update from Plante Moran Cresa (PMC) as it relates to the assignment to assist and advise Livonia Public Schools (LPS) in its selection of a Technology Contractor for the Projects listed above. This update represents the mutual efforts of PMC, IDS and LPS administration and staff (the Bond Team) to present a framework in order to identify, evaluate and recommend Vendors for these Projects.

On October 20, 2022, Bid Documents were formally issued and made available. An advertisement for bids was published in a local newspaper and also posted to the required State of Michigan websites.

On November 10, 2022, twenty (20) bid proposals were received and publicly opened. Over the next few days, the bid proposals were reviewed to determine the budget implications. Interviews were held with the bidders over the course of the next few weeks. The scope of work, project schedule, phasing, manpower requirements, and other particulars regarding the work were reviewed and discussed.

Upon completion of the interviews, and after subsequent clarifications and discussions, the Bond Team is recommending **Sentinel** for contract award as detailed in IDS' recommendation letter dated January 13, 2023.

Including the Base Bid Amount of \$1,230,009.38, acceptance of Alternate 02 in the amount of \$360,533.28 and a contingency amount of \$300,000.00, the total Project award recommendation equals **\$1,890,542.66**.

The costs for this work will be detailed in the Contract, which was included in this RFP, pending final review and approval of terms by district legal counsel.

The Project Team is available at the Board's convenience to answer any questions regarding bidding, the proposals, interview process, or the recommendations of the Bond Team. Please direct all questions through me via email at brian.weber@plantemoran.com.

Sincerely,

PLANTE MORAN CRESA



Brian Weber
Vice President

Enclosures: Summary of Costs
 IDS Recommendation Letter



TECHNOLOGY - SECURITY CAMERAS
BUDGET SUMMARY

	Base Cost		
Buildings	Budget	Actual	Variance
District-Wide	\$ 1,410,000	\$ 1,590,542.66	\$ (180,542.66)
Totals	\$ 1,410,000	\$ 1,590,542.66	\$ (180,542.66)

	Contingency		
Buildings	Budget	Actual	Variance
District-Wide	\$ 140,000	\$ 300,000.00	\$ (160,000.00)
Totals	\$ 140,000	\$ 300,000.00	\$ (160,000.00)

	Total Project Costs		
Buildings	Budget	Actual	Variance
District-Wide	\$ 1,550,000	\$ 1,890,542.66	\$ (340,542.66)
Totals	\$ 1,550,000	\$ 1,890,542.66	\$ (340,542.66)

January 13, 2023

Mr. Phillip Francis
 Assistant Superintendent of district Services
 Livonia Public Schools
 15125 Farmington Road
 Livonia, MI 48154

Project Name: Livonia Public Schools
 Security Camera Upgrades
 Livonia, Michigan

IDS Project No.: 21191-1000 BP03

Dear Mr. Francis:

Bid specifications and drawings for the Security Camera Upgrades project were issued on October 20, 2022. The bid documents allowed for bidders to submit cloud based and/or on-premises video management systems for the district to consider. The bid scope included demolition of existing security cameras and installation of new security cameras. Reuse, relocate and provide new Category 6 data cabling and provide a new video management system. Also included was aiming, programming, testing, and documentation services. The bid documents requested pricing for 5 years (Base Bid), 7 years (Mandatory Alternate 1) and 10 years (Mandatory Alternate 2) of warranty, support and licensing to provide a turnkey security camera and video management system in all the District's buildings. The bid documents reflected an engineered solution and provided quantities and types of cameras as well as desired camera coverage for both interior and exterior locations.

Representatives from twenty-five (25) companies attended the pre-bid conference on October 27, 2022. The pre-bid conference was not mandatory.

Twenty (20) bids from seventeen (17) companies were received on November 10, 2022, as follows:

Bidder	Bid Bond	Required Affidavits	Base Bid	MA 1 7 year warranty & licensing	MA 2 10 year warranty & licensing
Vector Tech Group	Yes	Yes	\$131,012.00	N/A	N/A
Sentinel - Bid 2	Yes	Yes	\$1,230,009.38	N/A	\$360,533.28
Sentinel - Bid 1 (withdrawn)	Yes	Yes	\$1,437,587.40	\$72,304.64	\$175,484.48
Telecom Technicians	Yes	Yes	\$1,495,471.00	\$2,720.00	\$6,800.00
Amcomm Telecommunications	Yes	Yes	\$1,507,100.00	N/A	N/A
Delta Network Services	Yes	Yes	\$1,525,430.57	\$17,356.34	\$43,390.86
Modern Fire & Security Systems	Yes	Yes	\$1,568,474.13	\$156,847.41	N/A
Moss Telecom	Yes	Yes	\$1,625,719.13	N/A	N/A
Creek Enterprises	Yes	Yes	\$1,663,898.00	\$357,738.00	\$534,111.00
People Driven Technologies	Yes	Yes	\$1,711,265.27	\$147,655.20	\$369,138.00
Security 101	Yes	Yes	\$1,731,257.98	\$188,955.78	\$274,843.56
ADT Commercial	Yes	Yes	\$1,749,461.47	\$49,771.00	\$100,067.00
CBTS	Yes	Yes	\$1,877,718.99	N/A	N/A
Knightwatch - Bid 2	Yes	Yes	\$1,886,422.02	\$144,361.76	\$309,014.78
Convergent Technologies	Yes	Yes	\$1,999,771.00	\$245,000.00	\$785,000.00
D/A Central	Yes	Yes	\$2,022,858.00	\$95,000.00	\$287,500.00
Inacomp TSG	Yes	Yes	\$2,295,550.00	N/A	\$732,105.57
CDW Education - Bid 1	Yes	Yes	\$2,337,488.14	\$41,429.99	N/A
Knightwatch - Bid 1	Yes	Yes	\$2,363,950.05	\$264,528.90	\$593,929.51
CDW Education - Bid 2	Yes	Yes	\$3,261,059.37	N/A	\$335,458.20

During the technology team's review of the bids, it was determined that Vector Tech Group's bid submission was noncompliant as they did not include security cameras and the video management system as part of their bid. Amcomm Telecommunications bid did not include Mandatory Alternate pricing for 7 years and 10 years of warranty, support and licensing as required.

Interviews were conducted with Sentinel, Telecom Technicians and Delta Network Services.

Sentinel: Sentinel submitted two (2) bids for two (2) different cloud based security camera systems. During the technology team's review, various pricing and equipment discrepancies were noted between Sentinel's Base Bid, their Bid Form and their included Bill of Materials for both of their submitted bid responses. Sentinel subsequently withdrew their Bid No. 1 as well as Voluntary Alternate No. 1 for their Bid No. 2 response for an alternate camera model. During their interview, Sentinel stated they would provide the quantity and types of cameras necessary to achieve the coverage and design intent of the Bid Documents for their Base Bid amount as submitted. Additional performance discrepancies were noted with some of their submitted equipment and cabling. Sentinel stated they would provide equipment and cabling models that meet the Bid Specifications. The manufacturer that Sentinel submitted includes a standard 10 year hardware warranty. Sentinel's Mandatory Alternate pricing discrepancies were discussed and clarified, and Sentinel stated that their Mandatory Alternate No. 2 included pricing for 10 years of licensing for all the equipment being provided.

Telecom Technicians: Telecom Technicians submitted a bid for an on-premises based security camera system. During the technology team's review, discrepancies were noted in the quantity of cameras included in their Bill of Materials. Telecom Technicians subsequently clarified that using their included unit pricing, the cost to add those cameras to their Base Bid would be \$31,533.00. Additional performance discrepancies were noted with the cabling part number submitted. Telecom Technicians stated they would provide cabling that meets the Bid Specifications. The manufacturer Telecom Technicians submitted does not offer warranties longer than five (5) years. Telecom Technicians mandatory alternate prices included labor only for them to troubleshoot the issue. Replacement/repair of the equipment is not included in their pricing.

Delta Network Services: Delta Network Services submitted a bid for an on-premises based security camera system. During the technology team's review, discrepancies were noted in the quantity of cameras included in their Bill of Materials. Delta Network Services subsequently clarified that using their included unit pricing, the cost to add those cameras and additional server storage to their Base Bid would be \$47,269.35. Additional performance discrepancies were noted with the cabling part number submitted. Delta Network Services stated they would provide cabling that meets the Bid Specifications. Delta Network Services Mandatory Alternate pricing included all warranty, support and licensing costs in their pricing for all equipment with the exception of the storage appliances. The manufacturer would only provide a five (5) year warranty. Delta Network Services received confirmation from the manufacturer that their Mandatory Alternate pricing as submitted does include the storage appliances for a total period of seven (7) years. The manufacturer was not able to offer a warranty extension to ten (10) years for the storage appliances.

After the interviews, the Livonia team requested additional product demonstrations from the bidders. While all three (3) solutions were deemed acceptable, the Livonia team strongly preferred the video management system interface, analytics and search capabilities of the cloud based solution submitted by Sentinel as Bid No. 2. **IDS recommends award of the Security Camera Upgrades bid to Sentinel in the amount of \$1,590,542.66 which includes Base Bid \$1,230,009.38 + Mandatory Alternate 2 for a 10 year warranty and licensing \$360,533.28. In addition to the award amount, IDS is recommending a construction contingency be established in the amount of \$300,000.00.**

Sincerely,

Integrated Design Solutions, LLC



Scott Smith
Senior Associate



Rock Morey
Project Manager

ec: T. Klan, LPS
B. Weber, PMC
File

**LIVONIA PUBLIC SCHOOLS
BOARD OF EDUCATION MEETING
January 30, 2023**

TOPIC: Approval of Bid Results for Early Childhood Center - 2021 Bond

RECOMMENDATION:

Move that the Board of Education of the Livonia Public Schools School District approve the recommendation from its Owner's Representative, Plante Moran Cresa, and its Construction Manager, Clark Construction Company, to approve the contractors identified and the construction project budgets for the Early Childhood Center Addition and Renovations, in the total amount of \$27,668,021 which includes costs for hard construction, fees, and contingency and authorize the Superintendent or her designee to negotiate and execute final contracts on behalf of the Board of Education with the awarded contractors.

RATIONALE:

The recommended contractors for this project will provide the construction work needed to complete the renovations and addition of the Early Childhood Center. This is a planned project from the 2021 Bond.

BUDGETARY INFORMATION:

2021 Bond

RESOURCE PERSONNEL:

Phillip Francis, Assistant Superintendent of District Services

EXHIBITS:

Attached

PF/ko

January 19, 2023

Mr. Phillip Francis
Asst. Superintendent of District Services
Livonia Public Schools
15125 Farmington Road
Livonia, MI 48154

RE: 2021 Bond Program
Contract Award Recommendation for Construction Bids
LPS Early Childhood Center – Addition & Renovations

Dear Mr. Francis:

This letter transmits an update from Plante Moran Cresa (PMC) as it relates to the assignment to assist and advise Livonia Public Schools (LPS) in its selection of Prime Contractors for the Project listed above. This update represents the mutual efforts of PMC, Clark Construction Co., TMP Architects, and LPS administration and staff (the Bond Team) to present a framework in order to identify, evaluate and recommend Prime Contractors for this Project.

On December 6, 2022, Construction Documents were formally issued and made available. An advertisement for bids was published in a local newspaper, posted to the required State of Michigan websites and forwarded to multiple construction bidding websites.

On January 10, 2023, 90 bid proposals were received, and over the next several days were reviewed to determine the budget implications. Interviews were also held during this time and were attended by various members of the Bond Team.

Upon completion of the interviews, and after subsequent clarifications and discussions, the Bond Team is recommending the firms listed in Clark Construction Co.'s Award Recommendation Letter dated January 19, 2023 for contract award.

The recommendation includes the acceptance of Alternate #3 for the installation of a movable glass partition at the front office conference room for an added amount of \$34,168 as further detailed in Clark's recommendation letter.

Including hard construction of \$25,125,337.00, CM costs and fees of \$1,035,164.00, and construction contingency of \$1,507,520, this Project award recommendation equals **\$27,668,021**.

For the Prime Contractors, the costs for this work will be detailed in AIA Contract A132 – 2019 Standard Form of Agreements between Owner and Contractor pending final review and approval of terms by district legal counsel.

The Project Team is available at the Board's convenience to answer any questions regarding bidding, the proposals, interview process, or the recommendations of the Bond Team. Please direct all questions through me via email at brian.weber@plantemoran.com.

Sincerely,

PLANTE MORAN CRESA



Brian Weber
Vice President

Enclosures: Budget Summary
 Clark Construction Co. Award Recommendation Letter
 Summary of Costs
 Bid Tabulations



LPS EARLY CHILDHOOD CENTER - ADDITION & RENOVATIONS
BUDGET SUMMARY

	Hard Construction*		
Building	Budget	Actual	Variance
ECC	\$ 23,970,000	\$ 25,125,337	\$ (1,155,337)
Totals	\$ 23,970,000	\$ 25,125,337	\$ (1,155,337)

	CM Fees/Costs		
	Budget	Actual	Variance
Staffing	Included within the CM Contract		
Reimbursables	Included within the CM Contract		
General Conditions (2%)	\$ 479,400	\$ 502,507	\$ (23,107)
CM Fee (2%)	\$ 512,920	\$ 532,657	\$ (19,737)
Totals	\$ 992,320	\$ 1,035,164	\$ (42,844)

	Construction Contingency (6%)		
Building	Budget	Actual	Variance
ECC	\$ 1,676,000	\$ 1,507,520	\$ 168,480
Totals	\$ 1,676,000	\$ 1,507,520	\$ 168,480

	Total Project Costs		
Building	Budget	Actual	Variance
ECC	\$ 26,638,320	\$ 27,668,021	\$ (1,029,701)
Totals	\$ 26,638,320	\$ 27,668,021	\$ (1,029,701) **

*Roofing and Playground bid packages are not included. These will be presented at a later date.

**The budget overage will be funded from the Owner's Contingency within the Bond Program



Headquarters
 3535 Moores River Drive
 Lansing, MI 48911
 517.372.0940 phone | 517.372.0668 fax
www.clarkcc.com

Southeast MI Office
 2660 Superior Court
 Auburn Hills, MI 48326
 248.286.1000 phone

Northern MI Office
 3432 US 23 South
 Alpena, MI 49707
 989.278.2272 phone

Livonia Public Schools – Phase # 2 Bid Package No. 5 Early Childhood Center

1/19/23

Mr. Phillip M. Francis - Asst. Superintendent of District Services
 Livonia Public Schools
 15125 Farmington Rd
 Livonia, MI 48154

Re: Livonia Public Schools – 2021 Bond Program
 Contract Award Recommendations 21-2867
 Phase # 2 Bid Package # 5 – Early Childhood Center

Dear Mr. Francis,

Bids for phase #2, Bid Package #5 were received on January 10th, for 22 bid categories from the plans and specifications issued by TMP Architecture dated 11/30/22. Clark Construction Company, TMP Architecture, along with Plante Moran Cresa have conducted post bid interview meetings with the low qualified recommended bidders. The bidders have also been through our pre-qualification process. The pre-qualification process includes the review of the trade contractors past financials, bonding capacity, safety rating, labor capacity during the project schedule and reference calls regarding past projects. We have received each Contractor’s assurance that they are committed to meeting the requirements of the Contract Documents.

In addition to the direct Trade Contractor costs, Clark Construction Company recommends including a Construction Contingency amount of 6% for any unforeseen issues, General Condition budget amount of 2% related to items such as building permits, security and safety requirements, temporary utilities, etc. No costs will be committed without prior approval of the District Administration for each item. Clark Construction, Construction Manager’s Fee of 2% based on the Trade Contract cost plus the contingency cost.

We are recommending the Board award contracts in the amount of \$25,125,337 Clark Construction Company recommends Livonia Public Schools enter into Contracts with each of the Trade Contractors listed below. The recommended Trade Contractors provided the lowest qualified bid for the Work.

BID PACK #5 – AWARD RECOMMENDATIONS

Listed below are the Bidders for which we recommend Board of Education approval to issue contracts and enclosed are Bid tabulations for the recommended Bid Categories of Work.



Michigan’s First
 Platinum Contractor

2017, 2015 & 2013 AGC
 National Safety
 Excellence Award

An Equal Opportunity
 Employer



Headquarters
 3535 Moores River Drive
 Lansing, MI 48911
 517.372.0940 phone | 517.372.0668 fax
www.clarkcc.com

Southeast MI Office
 2660 Superior Court
 Auburn Hills, MI 48326
 248.286.1000 phone

Northern MI Office
 3432 US 23 South
 Alpena, MI 49707
 989.278.2272 phone

Bid Category & Description	Contractor	Bid Amount
02A - Building & Selective Demolition	Blue Star, Inc.	\$ 966,900
03A - Concrete Flatwork	Midtown Group LLC	\$ 594,200
03B - Building Foundations	Midtown Group LLC	\$ 1,025,000
04A - Masonry	D'Aloisio Masonry and Construction Company	\$ 695,620
05A - Structural Steel	Duke and Duke Services	\$ 2,243,300
06A - Rough -Finish Carpentry & General Trades	Wally Kosorski & Co.,Inc.	\$ 1,907,400
07A - Roofing		No Bid
07B - Metal Panels & Siding	Liberty Sheet Metal, Inc.	\$ 693,795
08A - Entrances & Storefronts, Windows, Curtain Wall	Daniels Glass, Inc.	\$ 878,346
09A - Metal Studs, Gypboard & Acoustic Ceilings	Pontiac Ceiling and Partition Co.,LLC,	\$ 4,475,200
09B - Hard Tile	Omega Floors, Inc	\$ 78,600
09C - Carpet & Resilient Flooring	Shock Brothers Floorcovering, Inc.	\$ 592,850
09D - Painting & Wall Covering	Conci Painting, LLC	\$ 224,500
10A - Toilet Accessories	Rayhaven Group, Inc	\$ 33,435
10C - Metal Lockers	Rayhaven Group, Inc.	\$ 2,000
011A - Food Service	Great Lakes Hotel Supply Company	\$ 115,030
012A - Manufactured Casework	FCI Group, LLC	\$ 477,600
012C - Window Treatments	The Sheer Shop, Inc.	\$ 26,881
021A - Fire Protection	Phantom Fire Protection Inc.	\$ 307,680
022A - Plumbing	Contrast Mechanical, Inc	\$ 1,455,000
023A - HVAC	Quality Aire Systems, Inc.	\$ 2,788,000
026A - Electrical	Green Line Electric, LLC	\$ 2,090,000
031A - Earthwork & Utilities	Eastside Equipment, LLC dba Simone Construction Services	\$ 3,454,000
Trade Contracts Total:		\$ 25,125,337
Construction contingency (6%)		\$ 1,507,520
Construction Cost Total		\$ 26,632,857
Clark Construction Cost:		
General Conditions (2% x \$25,125,337)		\$ 502,507
Construction Manager's Fee (2% x \$26,621,730)		\$ 532,657
Total amount of Board Approval		\$ 27,668,021

*07A – Roofing bids were not received and this bid category will be rebid at later date.



Michigan's First
 Platinum Contractor

2017, 2015 & 2013 AGC
 National Safety
 Excellence Award

An Equal Opportunity
 Employer



Headquarters
3535 Moores River Drive
Lansing, MI 48911
517.372.0940 phone | 517.372.0668 fax
www.clarkcc.com

Southeast MI Office
2660 Superior Court
Auburn Hills, MI 48326
248.286.1000 phone

Northern MI Office
3432 US 23 South
Alpena, MI 49707
989.278.2272 phone

** 02, 09A, 09D Bid Categories low bidder did not qualify there bid and sent Clark Construction emails that they would like to pull their bid due to estimating errors.

The bidders had four alternates they also submitted cost for and Livonia Bond Team, TMP Architecture and Clark Construction has decided to accept the following alternates

- 1) Will not accept the Alternate # 1 - the Mechanical screen walls will stay in place
- 2) Will not accept the Alternate # 2 - Keep the Casework as designed in the documents
- 3) Will accept the Alternate # 3 - Install the Nana Wall in between rooms A133 and A134. This is an addition cost of \$34,168.
- 4) Will not accept the Alternate # 4 - Not to accept the Block and Brick masonry around the dumpster and generator enclosures.

The costs associated with these alternates have been added or deducted to the trade contractors base bid amount in the recommendation letter.

Sincerely,

Andrew J. Holewinski
Clark Construction Company



Michigan's First
Platinum Contractor

2017, 2015 & 2013 AGC
National Safety
Excellence Award

An Equal Opportunity
Employer



ALTERNATES - TOTAL CONSTRUCTION COST

Alternate 01 - Remove Mechanical Screen Walls	Alternate Bid Cost
005A - Structural Steel	\$ (11,830)
007B - Metal Panels & Siding	\$ (72,485)
009A - Metal Studs, Gypboard & Acoustic Ceilings	\$ (3,200)
023A - HVAC	
TOTALS	\$ (87,515)

Not Accepted

Alternate 02 - Remove Millwork in Classrooms	Alternate Bid Cost
012A - Manufactured Casework	\$ (80,000)
TOTALS	\$ (80,000)

Not Accepted

Alternate 03 - Add Nanawall Between Conference Room A133 and A134	Alternate Bid Cost
003B - Building Foundations	
005A - Structural Steel	\$ 3,300
008A - Entrances & Storefronts, Windows, Curtain Wall	\$ 31,868
009A - Metal Studs, Gypboard & Acoustic Ceilings	\$ (800)
009B - Painting & Wall Covering	\$ (200)
TOTALS	\$ 34,168

Accepted



ALTERNATES - TOTAL CONSTRUCTION COST

Alternate 04 - Provide Masonry Enclosure at Generator/Transformer Fence Enclosure	Alternate Bid Cost
003B - Building Foundations	\$ 40,500
004A - Masonry	\$ 69,350
032D - Fencing	
031A - Earthwork & Utilities	\$ 16,000
7 General Trade - Wood Gate	
TOTALS	\$ 125,850

Not Accepted

)



Livonia Schools Early Childhood Center - BID RESULTS

002A - Building & Selective Demolition								
Contractor	Blue Star, Inc.	Christman Constructors, Inc.	Adamo Demolition Co.	Demolition Contractors, Inc. Dba Pitsch Wrecking, Inc.	Detroit Dismantling Corporation	Homrich Wrecking, Inc. dba Homrich, Inc.		
Base Bid	\$ 966,900	\$ 659,300	\$ 1,164,270	\$ 972,000	\$ 1,200,000	\$ 1,417,000	\$ -	\$ -
Alternate 01 - Remove Mechanical Screen Walls	\$ -	\$ -	\$ -	\$ -	\$ -	\$ -	\$ -	\$ -
Alternate 02 - Remove Millwork in Classrooms	\$ -	\$ -	\$ -	\$ -	\$ -	\$ -	\$ -	\$ -
Alternate 03 - Add Nanawall Between Conference Room A133 and A134	\$ -	\$ -	\$ -	\$ -	\$ -	\$ -	\$ -	\$ -
Alternate 04 - Provide Masonry Enclosure at Generator/Transformer Fence Enclosure	\$ -	\$ -	\$ -	\$ -	\$ -	\$ -	\$ -	\$ -

003A - Concrete Flatwork								
Contractor	Albanelli Cement Contractors, Inc.	McCarthy Construction Company	Eastside Equipment, LLC dba Simone Construction Services	Spence Brothers	Fessler & Bowman, Inc.	Midtown Group LLC	DSP Contracting	
Base Bid	\$ 721,400	\$ 688,563	\$ 694,700	\$ -	\$ 801,000	\$ 594,200	\$ 731,260	\$ -
Alternate 01 - Remove Mechanical Screen Walls	\$ -	\$ -	\$ -	\$ -	\$ -	\$ -	\$ -	\$ -
Alternate 02 - Remove Millwork in Classrooms	\$ -	\$ -	\$ -	\$ -	\$ -	\$ -	\$ -	\$ -
Alternate 03 - Add Nanawall Between Conference Room A133 and A134	\$ -	\$ -	\$ -	\$ -	\$ -	\$ -	\$ -	\$ -
Alternate 04 - Provide Masonry Enclosure at Generator/Transformer Fence Enclosure	\$ -	\$ -	\$ -	\$ -	\$ -	\$ -	\$ -	\$ -

003B - Building Foundations								
Contractor	Fessler & Bowman, Inc.	Midtown Group LLC	Spence Brothers	Brenca Contractors, Inc.	DeMaria Building Company, Inc.	JJ Barney Const. Inc.		
Base Bid	\$ 1,293,000	\$ 1,025,000	\$ 1,139,900	\$ -	\$ 1,763,693	\$ 1,129,900	\$ -	\$ -
Alternate 01 - Remove Mechanical Screen Walls	\$ -	\$ -	\$ -	\$ -	\$ -	\$ -	\$ -	\$ -
Alternate 02 - Remove Millwork in Classrooms	\$ -	\$ -	\$ -	\$ -	\$ -	\$ -	\$ -	\$ -
Alternate 03 - Add Nanawall Between Conference Room A133 and A134	\$ 9,500	\$ -	\$ 4,500	\$ -	\$ 2,750	\$ 3,975	\$ -	\$ -
Alternate 04 - Provide Masonry Enclosure at Generator/Transformer Fence Enclosure	\$ 42,500	\$ 40,500	\$ 40,500	\$ 44,000	\$ 74,000	\$ 44,875	\$ -	\$ -

004A - Masonry								
Contractor	Baker Construction Co., Inc.	Hicks Masonry Company LLC, dbaHMC Mason Contractors	Leidal & Hart Mason Contractors, Inc.	Brazen & Greer Masonry Inc	D'Aloisio Masonry and Construction Company	J & J Construction Company		
Base Bid	\$ 879,850	\$ 732,470	\$ 958,800	\$ 867,000	\$ 695,620	\$ 784,100	\$ -	\$ -
Alternate 01 - Remove Mechanical Screen Walls	\$ -	\$ -	\$ -	\$ -	\$ -	\$ -	\$ -	\$ -
Alternate 02 - Remove Millwork in Classrooms	\$ -	\$ -	\$ -	\$ -	\$ -	\$ -	\$ -	\$ -
Alternate 03 - Add Nanawall Between Conference Room A133 and A134	\$ -	\$ -	\$ -	\$ -	\$ -	\$ -	\$ -	\$ -
Alternate 04 - Provide Masonry Enclosure at Generator/Transformer Fence Enclosure	\$ 75,500	\$ 85,650	\$ 95,600	\$ 67,900	\$ 69,350	\$ 83,000	\$ -	\$ -

005A - Structural Steel								
Contractor	Howard Structural Steel, Inc.	Casadei Steel Inc.	Duke and Duke Services					
Base Bid	\$ 2,478,792	\$ 3,048,548	\$ 2,240,000	\$ -	\$ -	\$ -	\$ -	\$ -
Alternate 01 - Remove Mechanical Screen Walls	\$ (41,700)	\$ 166,953	\$ (11,830)	\$ -	\$ -	\$ -	\$ -	\$ -
Alternate 02 - Remove Millwork in Classrooms	\$ -	\$ -	\$ -	\$ -	\$ -	\$ -	\$ -	\$ -
Alternate 03 - Add Nanawall Between Conference Room A133 and A134	\$ (11,636)	\$ 4,882	\$ 3,300	\$ -	\$ -	\$ -	\$ -	\$ -
Alternate 04 - Provide Masonry Enclosure at Generator/Transformer Fence Enclosure	\$ -	\$ -	\$ -	\$ -	\$ -	\$ -	\$ -	\$ -



Livonia Schools Early Childhood Center - BID RESULTS

006A - Rough.Finish Carpentry & General Trades								
Contractor	City Contracting Services	Spence Brothers	Wally Kosorski & Co.,Inc.	Spieker Co.				
Base Bid	\$ 2,182,000	\$ 2,249,000	\$ 1,907,400	\$ 2,094,000	\$ -	\$ -	\$ -	\$ -
Alternate 01 - Remove Mechanical Screen Walls	\$ -	\$ -	\$ -	\$ -	\$ -	\$ -	\$ -	\$ -
Alternate 02 - Remove Millwork in Classrooms	\$ -	\$ -	\$ -	\$ -	\$ -	\$ -	\$ -	\$ -
Alternate 03 - Add Nanawall Between Conference Room A133 and A134	\$ -	\$ -	\$ -	\$ -	\$ -	\$ -	\$ -	\$ -
Alternate 04 - Provide Masonry Enclosure at Generator/Transformer Fence Enclosure	\$ -	\$ -	\$ -	\$ 18,000	\$ -	\$ -	\$ -	\$ -

007B - Metal Panels & Siding								
Contractor	Liberty Sheet Metal, Inc.							
Base Bid	\$ 693,795	\$ -	\$ -	\$ -	\$ -	\$ -	\$ -	\$ -
Alternate 01 - Remove Mechanical Screen Walls	\$ 72,485	\$ -	\$ -	\$ -	\$ -	\$ -	\$ -	\$ -
Alternate 02 - Remove Millwork in Classrooms	\$ -	\$ -	\$ -	\$ -	\$ -	\$ -	\$ -	\$ -
Alternate 03 - Add Nanawall Between Conference Room A133 and A134	\$ -	\$ -	\$ -	\$ -	\$ -	\$ -	\$ -	\$ -
Alternate 04 - Provide Masonry Enclosure at Generator/Transformer Fence Enclosure	\$ -	\$ -	\$ -	\$ -	\$ -	\$ -	\$ -	\$ -

008A - Entrances & Storefronts, Windows, Curtain Wall								
Contractor	Peterson Glass Company	Daniels Glass, Inc.	Aalcor, Inc.	Butcher & Butcher Construction Co., Inc.				
Base Bid	\$ 976,000	\$ 846,478	\$ 957,500	\$ 1,235,218	\$ -	\$ -	\$ -	\$ -
Alternate 01 - Remove Mechanical Screen Walls	\$ -	\$ -	\$ -	\$ -	\$ -	\$ -	\$ -	\$ -
Alternate 02 - Remove Millwork in Classrooms	\$ -	\$ -	\$ -	\$ -	\$ -	\$ -	\$ -	\$ -
Alternate 03 - Add Nanawall Between Conference Room A133 and A134	\$ 34,000	\$ 31,868	\$ 30,700	\$ 38,663	\$ -	\$ -	\$ -	\$ -
Alternate 04 - Provide Masonry Enclosure at Generator/Transformer Fence Enclosure	\$ -	\$ -	\$ -	\$ -	\$ -	\$ -	\$ -	\$ -

009A - Metal Studs, Gypboard & Acoustic Ceilings								
Contractor	Stenco Construction LLC	Pontiac Ceiling and Partition Co.,LLC, aka National Door Systems, LLC	Turner Brooks Inc.					
Base Bid	\$ 4,774,000	\$ 4,476,000	\$ 3,920,000	\$ -	\$ -	\$ -	\$ -	\$ -
Base Bid Valid								
Alternate 01 - Remove Mechanical Screen Walls	\$ -	\$ (3,200)	\$ -	\$ -	\$ -	\$ -	\$ -	\$ -
Alternate 02 - Remove Millwork in Classrooms	\$ -	\$ -	\$ -	\$ -	\$ -	\$ -	\$ -	\$ -
Alternate 03 - Add Nanawall Between Conference Room A133 and A134	\$ -	\$ (800)	\$ 1,890	\$ -	\$ -	\$ -	\$ -	\$ -
Alternate 04 - Provide Masonry Enclosure at Generator/Transformer Fence Enclosure	\$ -	\$ -	\$ -	\$ -	\$ -	\$ -	\$ -	\$ -



Livonia Schools Early Childhood Center - BID RESULTS

009B - Painting & Wall Covering								
Contractor	Conci Painting Inc	GV Painting, LLC	Continental Contracting LLC	G & T Commercial Coatings, Inc.				
Base Bid	\$ 224,700	\$ 279,100	\$ 345,000	\$ 169,448	\$ -	\$ -	\$ -	\$ -
Alternate 01 - Remove Mechanical Screen Walls	\$ -	\$ -	\$ -	\$ -	\$ -	\$ -	\$ -	\$ -
Alternate 02 - Remove Millwork in Classrooms	\$ -	\$ -	\$ -	\$ -	\$ -	\$ -	\$ -	\$ -
Alternate 03 - Add Nanawall Between Conference Room A133 and A134	\$ (200)	\$ (1,150)	\$ -	\$ (1,300)	\$ -	\$ -	\$ -	\$ -
Alternate 04 - Provide Masonry Enclosure at Generator/Transformer Fence Enclosure	\$ -	\$ -	\$ -	\$ -	\$ -	\$ -	\$ -	\$ -

009C - Carpet & Resilient Flooring								
Contractor	Turner Brooks Inc.	Omega Floors, inc	Shock Brothers Floorcovering, Inc.					
Base Bid	\$ 650,770	\$ 633,000	\$ 592,850	\$ -	\$ -	\$ -	\$ -	\$ -
Alternate 01 - Remove Mechanical Screen Walls	\$ -	\$ -	\$ -	\$ -	\$ -	\$ -	\$ -	\$ -
Alternate 02 - Remove Millwork in Classrooms	\$ -	\$ -	\$ -	\$ -	\$ -	\$ -	\$ -	\$ -
Alternate 03 - Add Nanawall Between Conference Room A133 and A134	\$ -	\$ -	\$ -	\$ -	\$ -	\$ -	\$ -	\$ -
Alternate 04 - Provide Masonry Enclosure at Generator/Transformer Fence Enclosure	\$ -	\$ -	\$ -	\$ -	\$ -	\$ -	\$ -	\$ -

009D - Hard Tile								
Contractor	R&G Painting	Michielutti Bros Inc	Artisan Tile Inc	Omega Floors, inc				
Base Bid	\$ 121,000	\$ 104,600	\$ 99,301	\$ 78,600	\$ -	\$ -	\$ -	\$ -
Alternate 01 - Remove Mechanical Screen Walls	\$ -	\$ -	\$ -	\$ -	\$ -	\$ -	\$ -	\$ -
Alternate 02 - Remove Millwork in Classrooms	\$ -	\$ -	\$ -	\$ -	\$ -	\$ -	\$ -	\$ -
Alternate 03 - Add Nanawall Between Conference Room A133 and A134	\$ -	\$ -	\$ -	\$ -	\$ -	\$ -	\$ -	\$ -
Alternate 04 - Provide Masonry Enclosure at Generator/Transformer Fence Enclosure	\$ -	\$ -	\$ -	\$ -	\$ -	\$ -	\$ -	\$ -

011A - Food Service								
Contractor	Stafford-Smith, Inc.	Great Lakes Hotel Supply Company						
Base Bid	\$ 118,766	\$ 115,030	\$ -	\$ -	\$ -	\$ -	\$ -	\$ -
Alternate 01 - Remove Mechanical Screen Walls	\$ -	\$ -	\$ -	\$ -	\$ -	\$ -	\$ -	\$ -
Alternate 02 - Remove Millwork in Classrooms	\$ -	\$ -	\$ -	\$ -	\$ -	\$ -	\$ -	\$ -
Alternate 03 - Add Nanawall Between Conference Room A133 and A134	\$ -	\$ -	\$ -	\$ -	\$ -	\$ -	\$ -	\$ -
Alternate 04 - Provide Masonry Enclosure at Generator/Transformer Fence Enclosure	\$ -	\$ -	\$ -	\$ -	\$ -	\$ -	\$ -	\$ -

012A - Manufactured Casework								
Contractor	FCI Group, LLC							
Base Bid	\$ 477,600	\$ -	\$ -	\$ -	\$ -	\$ -	\$ -	\$ -
Alternate 01 - Remove Mechanical Screen Walls	\$ -	\$ -	\$ -	\$ -	\$ -	\$ -	\$ -	\$ -
Alternate 02 - Remove Millwork in Classrooms	\$ 80,000	\$ -	\$ -	\$ -	\$ -	\$ -	\$ -	\$ -
Alternate 03 - Add Nanawall Between Conference Room A133 and A134	\$ -	\$ -	\$ -	\$ -	\$ -	\$ -	\$ -	\$ -
Alternate 04 - Provide Masonry Enclosure at Generator/Transformer Fence Enclosure	\$ -	\$ -	\$ -	\$ -	\$ -	\$ -	\$ -	\$ -



Livonia Schools Early Childhood Center - BID RESULTS

031A - Earthwork & Utilities								
Contractor	Nagle Paving Company	Best Asphalt, Inc.	Eastside Equipment, LLC dba Simone Construction Services	Fessler & Bowman, Inc.				
Base Bid	\$ 4,994,900	\$ 3,470,000	\$ 3,454,000	\$ 3,469,730	\$ -	\$ -	\$ -	\$ -
Alternate 01 - Remove Mechanical Screen Walls	\$ -	\$ -	\$ -	\$ -	\$ -	\$ -	\$ -	\$ -
Alternate 02 - Remove Millwork in Classrooms	\$ -	\$ -	\$ -	\$ -	\$ -	\$ -	\$ -	\$ -
Alternate 03 - Add Nanawall Between Conference Room A133 and A134	\$ -	\$ -	\$ -	\$ -	\$ -	\$ -	\$ -	\$ -
Alternate 04 - Provide Masonry Enclosure at Generator/Transformer Fence Enclosure	\$ (5,000)	\$ (23,850)	\$ 16,000	\$ (18,000)	\$ -	\$ -	\$ -	\$ -

010A - Toilet Accessories								
Contractor	R.E. Leggette Co.	Rayhaven Group, Inc.						
Base Bid	\$ 46,595	\$ 33,435	\$ -	\$ -	\$ -	\$ -	\$ -	\$ -
Alternate 01 - Remove Mechanical Screen Walls	\$ -	\$ -	\$ -	\$ -	\$ -	\$ -	\$ -	\$ -
Alternate 02 - Remove Millwork in Classrooms	\$ -	\$ -	\$ -	\$ -	\$ -	\$ -	\$ -	\$ -
Alternate 03 - Add Nanawall Between Conference Room A133 and A134	\$ -	\$ -	\$ -	\$ -	\$ -	\$ -	\$ -	\$ -
Alternate 04 - Provide Masonry Enclosure at Generator/Transformer Fence Enclosure	\$ -	\$ -	\$ -	\$ -	\$ -	\$ -	\$ -	\$ -

010C - Metal Lockers								
Contractor	Rayhaven Group, Inc.							
Base Bid	\$ 2,000	\$ -	\$ -	\$ -	\$ -	\$ -	\$ -	\$ -
Alternate 01 - Remove Mechanical Screen Walls	\$ -	\$ -	\$ -	\$ -	\$ -	\$ -	\$ -	\$ -
Alternate 02 - Remove Millwork in Classrooms	\$ -	\$ -	\$ -	\$ -	\$ -	\$ -	\$ -	\$ -
Alternate 03 - Add Nanawall Between Conference Room A133 and A134	\$ -	\$ -	\$ -	\$ -	\$ -	\$ -	\$ -	\$ -
Alternate 04 - Provide Masonry Enclosure at Generator/Transformer Fence Enclosure	\$ -	\$ -	\$ -	\$ -	\$ -	\$ -	\$ -	\$ -

Andrew Holewinski

From: Sean Webber <swebber@christmanconstructors.com>
Sent: Thursday, January 12, 2023 7:59 AM
To: Andrew Holewinski
Cc: Andrew Holman
Subject: LPS Early Childhood Center Proposal Withdrawal

Please Be Cautious

This email was sent from an address outside of clarkcc.com. Please be sure this message is coming from a trusted address.

Good morning Andrew,

As discussed in the post bid meeting, I identified scope items following bid submission that were not included in our proposal. additional roof removal work added to the demolition scope of work in addendum 3. The omission of this work resulted in an will be withdrawing our proposal for this project.

Thank you for your time and good luck with the project.

Sean Webber
Estimator - Demolition and Restoration Services
Christman Constructors, Inc.
14111 Farmington Road
Livonia, MI 48154
p. 734-245-0136

Our Purpose: To Unite Great People in Great Achievement

Our People: Experts. Leaders. Partners.



**LIVONIA PUBLIC SCHOOLS
BOARD OF EDUCATION MEETING
January 30, 2023**

TOPIC: Approval of Bid Results for Franklin Tennis Courts

RECOMMENDATION:

Move that the Board of Education of the Livonia Public Schools School District accept the recommendation from its Owner's Representative, Plante Moran Cresa, and its Designer, Foresite Design, Inc., to approve the contractors identified and the construction project budget for the Franklin High School Tennis Courts Project in the total amount of \$1,213,740, which includes costs for hard construction and contingency, and authorize the Superintendent or her designee to negotiate and execute final contracts on behalf of the Board of Education with the awarded contractors.

RATIONALE:

This is a planned Sinking Fund project based on the District's 10-year facility plan. It will provide needed updates and improvements at the Franklin High School tennis courts.

BUDGETARY INFORMATION:

Sinking Fund

RESOURCE PERSONNEL:

Phillip Francis, Assistant Superintendent of District Services

EXHIBITS:

Attachments

PF/ko

January 16, 2023

Mr. Phillip Francis
Asst. Superintendent of District Services
Livonia Public Schools
15125 Farmington Road
Livonia, MI 48154

RE: Sinking Fund Projects
Contract Award Recommendation for Construction Bids
Franklin HS Tennis Court Replacement

Dear Mr. Francis:

This letter transmits an update from Plante Moran Cresa (PMC) as it relates to the assignment to assist and advise Livonia Public Schools (LPS) in its selection of Prime Contractors for the Project listed above. This update represents the mutual efforts of PMC, Foresite Design, Inc., LPS administration and staff (the Team) to present a framework in order to identify, evaluate and recommend Prime Contractors for these Projects.

On November 28, 2022, Construction Documents were formally issued and made available. An advertisement for bids was published in a local newspaper and also posted to the required State of Michigan website.

On December 13, 2022, five (5) bid proposals for two (2) bid categories were received for the Project and were subsequently reviewed to determine the budget implications. Interviews were conducted on December 14, 2022 and were attended by representatives from Foresite Design, PMC, and LPS. The scope of work, project schedule, manpower requirements, and other particulars regarding the work were reviewed and discussed.

Upon completion of the interviews, and after subsequent clarifications and discussions, the Team is recommending the firms listed in Foresite Design's letter dated January 9, 2023.

Including hard construction of \$1,123,834 and construction contingency of \$89,906 (8%), this Project award recommendation equals **\$1,213,740.00**.

For the Prime Contractors, the costs for this work will be detailed in AIA Contract A105 – 2017 Standard Form of Agreement between Owner and Contractor, pending final review and approval of terms by district legal counsel.

The Project Team is available at the Board's convenience to answer any questions regarding bidding, the proposals, interview process, or the recommendation herein. Please direct all questions through me via email at brian.weber@plantemoran.com.

Mr. Phillip Francis
Livonia Public Schools

January 16, 2023
Page 2

Sincerely,

PLANTE MORAN CRESA



Brian Weber
Vice President

Enclosures: Budget Summary
 Foresite Design, Inc. Recommendation Letter
 Bid Tabulation



SINKING FUND - FRANKLIN HS TENNIS COURT REPLACEMENT
CONSTRUCTION BUDGET SUMMARY

	Hard Construction		
Buildings	Budget	Actual	Variance
Franklin HS - Tennis	\$ 1,142,600	\$ 1,123,834	\$ 18,766
Totals	\$ 1,142,600	\$ 1,123,834	\$ 18,766

	Construction Contingency (8%)		
Buildings	Budget	Actual	Variance
Franklin HS - Tennis	\$ 91,400	\$ 89,906	\$ 1,494
Totals	\$ 91,400	\$ 89,906	\$ 1,494

	Total Project Costs		
Buildings	Budget	Actual	Variance
Franklin HS - Tennis	\$ 1,234,000	\$ 1,213,740	\$ 20,260
Totals	\$ 1,234,000	\$ 1,213,740	\$ 20,260

January 9, 2023

Philip Francis
Director of Operations
Livonia Public Schools
15125 Farmington Road
Livonia, MI 48154

RE: Livonia Public Schools
Franklin High School – 2023 Tennis Renovations
Letter of Recommendation

Dear Mr. Francis,

Enclosed, for your review, is a tabulation sheet of the bids submitted on December 13, 2022, for the Livonia Public Schools – Franklin High School 2023 Tennis Renovations. Proposals were separated into two bid categories, which we received a total of five bids.

Post Bid Interviews were conducted with the apparent low bidders on December 14th, 2022. Our recommendations for award to the lowest responsible bidders are as follows:

Proposal A Site Work:

We recommend **Nagle Paving Company** of Novi, Michigan to complete the work as identified in Proposal A Site Work for the contract sum of **\$977,690.00**. The contract sum is based on the following breakdown:

Proposal A Base Bid:	\$ 977,690.00
Total	\$ 977,690.00

Proposal B Fencing:

We recommend **RMD Holdings d/b/a Nationwide Construction Group** of Richmond, Michigan to complete the work as identified in Proposal B Fencing for the contract sum of **\$146,144.00**. The contract sum is based on the following breakdown:

Proposal B Base Bid:	\$ 146,144.00
Total	\$ 146,144.00

- The vendor recommended for award was not the “as-read” low bidder for this category but deemed to be the most responsive following the Post Bid Evaluations.

The total amount recommended for award is as follows:

Nagle Paving Company	\$ 977,690.00
RMD Holdings d/b/a Nationwide Construction Group	\$ 146,144.00
Recommended Project Total	\$ 1,123,834.00



Please advise our office of additional information that may be required from the recommended Contractor(s) so that we may secure on your behalf for presentation at the next Board of Education meeting.

If you have any questions or concerns pertaining to this information, please do not hesitate to contact our office.

Sincerely,

FORESITE DESIGN, INC.



Michael Sims

Encl : (2)



**Livonia Public Schools
Franklin High School
Tennis Court Reconstruction 2023**

Bids Due: 12/13/22 @ 2:00 P.M.

BIDDER:	BID SECURITY		IRAN SANCTION DOCUMENT		FAMILIAL DSCL.		ADD. #1		Proposal A - Site Work		
	BB	CC	Y	N	Y	N	Y	N	BASE BID	Alt #1: Re-install aggregate stone	REMARKS
Nagle Paving	BB	CC	Y	N	Y	N	Y	N	\$977,690.00	-\$20,000.00	Vol Alt (1)
	BB	CC	Y	N	Y	N	Y	N			
	BB	CC	Y	N	Y	N	Y	N			
	BB	CC	Y	N	Y	N	Y	N			
	BB	CC	Y	N	Y	N	Y	N			
	BB	CC	Y	N	Y	N	Y	N			
	BB	CC	Y	N	Y	N	Y	N			

****Bold Indicates Apparent Low Bidder**



**Livonia Public Schools
Franklin High School
Tennis Court Reconstruction 2023**

Bids Due: 12/13/22 @ 2:00 P.M.

BIDDER:	BID SECURITY		IRAN SANCTION DOCUMENT		FAMILIAL DSCL.		ADD. #1		Proposal B - Fencing	
	BB	CC	Y	N	Y	N	Y	N	BASE BID	REMARKS
Motor City Fence	BB	CC	Y	N	Y	N	Y	N	\$108,664.00	
Nationwide Construction Group	BB	CC	Y	N	Y	N	Y	N	\$146,144.00	
Action Traffic	BB	CC	Y	N	Y	N	Y	N	\$154,550.00	
American Fence	BB	CC	Y	N	Y	N	Y	N	\$200,834.00	
	BB	CC	Y	N	Y	N	Y	N		
	BB	CC	Y	N	Y	N	Y	N		
	BB	CC	Y	N	Y	N	Y	N		
	BB	CC	Y	N	Y	N	Y	N		

173

****Bold Indicates Apparent Low Bidder**



**LIVONIA PUBLIC SCHOOLS
BOARD OF EDUCATION MEETING
January 30, 2023**

TOPIC: **Approval of TMP Contract Amendment**

RECOMMENDATION:

Move that the Board of Education of the Livonia Public Schools School District approve the recommendation from the Owner’s Representative, Plante Moran Cresa, to approve a contract amendment for TMP Architecture, Inc., Bloomfield Hills, Michigan, in the amount of \$621,125.

RATIONALE:

This amendment is for additional design needs, requested by the district, for LCTC/Robotics and the Early Childhood Center projects.

BUDGETARY INFORMATION:

2021 Bond

RESOURCE PERSONNEL:

Phillip Francis, Assistant Superintendent of District Services

EXHIBITS:

Attached

PF/ko

January 19, 2023

Mr. Phillip Francis
Assistant Superintendent of District Services
Livonia Public Schools
15125 Farmington Road
Livonia, MI 48154

RE: 2021 Bond Program
Architectural/Engineering Design Services – Contract Amendment
Project #2 – LCTC/Robotics and Early Childhood Center Projects

Dear Mr. Francis:

This letter transmits an update from Plante Moran Cresa (PMC) as it relates to a request from TMP Architects for additional services associated with the design and construction administration phases of the LCTC/Robotics and Early Childhood Center projects within the 2021 Bond Program.

As a result of owner-requested changes to the scope of Work detailed in the initial AE RFP documents, TMP submitted a proposal for additional services based on increased design scope and corresponding extended construction administration phases. Following subsequent discussions with PMC, LPS and district legal counsel, the Project Team is recommending **Amendment No. 3 in the amount of \$621,125.00.**

LCTC/Robotics	\$ 137,525.00
Early Childhood Center	\$ 483,600.00
Total	\$ 621,125.00

If you have any questions regarding the above information, please feel free to contact me at 248-675-9812 or brian.weber@plantemoran.com. The Project Team is also available at the Board's convenience to answer any questions.

Sincerely,
PLANTE MORAN CRESA



Brian Weber
Owner Representative

CC: Dana Abrahams, Clark Hill
Attachments: Contract Amendment No. 3

AMENDMENT No. 3
TO AIA B132-2009 STANDARD FORM OF AGREEMENT BETWEEN OWNER AND ARCHITECT

THIS THIRD AMENDMENT TO THE STANDARD FORM OF AGREEMENT BETWEEN OWNER AND ARCHITECT (AIA B132-2009) (the “Third Amendment”) made and entered into as of January 31, 2023, (the “Effective Date”), is attached to and made part of the Standard Form of Agreement Between Owner and Architect, (AIA B132-2009), dated June 14, 2021, the First Amendment dated August 24, 2021, and the Second Amendment dated October 8, 2021 (collectively the “Agreement”), by and between **Livonia Public Schools**, a Michigan general powers school district, whose address is 15125 Farmington Road, Livonia, Michigan 48154 (hereinafter the “Owner”) and **TMP Architecture, Inc.**, whose address is 1191 West Square Lake Road, Bloomfield Hills, Michigan 48302 (hereinafter the “Architect”).

RECITALS

WHEREAS, Owner and Architect entered into a Standard Form of Agreement Between Owner and Architect for certain services and Projects more fully described therein; and

WHEREAS, Owner and Architect desire to modify the terms and conditions of the Agreement, based on the modifications contained in this Third Amendment.

NOW THEREFORE, for good and valuable consideration, the receipt and sufficiency of which are hereby acknowledged, the parties hereto agree as follows:

A. THE FOLLOWING PARAGRAPH WITHIN THE AGREEMENT IS AMENDED AND RESTATED IN ITS ENTIRETY AS FOLLOWS, AS IF THE SAME HAD BEEN ORIGINALLY INCORPORATED THEREIN:

§ 11.1 Compensation for Basic Services shall include an additional Fixed Fee of One Hundred Thirty Seven Thousand Five Hundred Twenty Five and 00/100 Dollars (\$137,525.00) for Livonia Career Technical Center/Robotics Additional Design Services (hereinafter “LCTC/Robotics”) and an additional Fixed Fee of Four Hundred Eighty Three Thousand Six Hundred and 00/100 Dollars (\$483,600.00) for Early Childhood Center Additional Design Services (hereinafter “ECC”), as detailed in Attachment A. Therefore, the total Compensation due the Architect under the Agreement is a Fixed Fee of One Million Eight Hundred Fifty Three Thousand One Hundred Twenty Five and 00/100 Dollars (\$1,853,125.00). Reimbursable Expenses shall remain the same as a not exceed amount of Sixty Six Thousand Five Hundred and 00/100 Dollars (\$66,500.00).

Document	Amount	Reimbursable Expenses	Revised Contract Amount
Base Contract	\$ 1,180,000.00	\$ 66,500.00	\$ 1,246,500.00
Amendment #1	52,000.00	0.00	1,298,500.00
Amendment #2	0.00	0.00	1,298,500.00
Amendment #3 – LCTC/Robotics	137,525.00	0.00	1,436,025.00
Amendment #3 – ECC	483,600.00	0.00	1,919,625.00
Totals:	\$ 1,853,125.00	\$ 66,500.00	\$ 1,919,625.00

B. THE AGREEMENT IS HEREBY RATIFIED AND REAFFIRMED, AND SHALL CONTINUE IN FULL FORCE AND EFFECT IN ACCORDANCE WITH THE PROVISIONS THEREOF EXCEPT AS MODIFIED BY THIS THIRD AMENDMENT. IN THE EVENT OF A CONFLICT BETWEEN THIS THIRD AMENDMENT AND THE AGREEMENT, THIS THIRD AMENDMENT SHALL CONTROL.

The parties have caused this Third Amendment to the Standard Form of Agreement Between Owner and Architect (AIA B132-2009) to be executed as of the Effective Date as first written above.

LIVONIA PUBLIC SCHOOLS,

TMP ARCHITECTURE, INC.,

OWNER *(Signature)*



ARCHITECT *(Signature)*

Andrea Oquist, Superintendent
(Printed name and title)

John Castellana, Chairman
(Printed name and title)

(date)

1/12/2023
(date)

**LIVONIA PUBLIC SCHOOLS
BOARD OF EDUCATION MEETING
January 30, 2023**

TOPIC: Approval to Purchase Playground Equipment for Webster RISE Program

RECOMMENDATION:

Move that the Board of Education of the Livonia Public Schools School District approve the purchase of elementary playground equipment for the Webster Elementary RISE Program from Kidstuff Playsystems, in care of Kennedy Recreation, Clinton Township, Michigan, in the amount of \$137,020, which includes contingency, and authorize the Superintendent or her designee to negotiate and execute final contracts on behalf of the Board of Education.

RATIONALE:

This purchase, for Webster's "Reaching Independence through Special Education" (RISE), is from our Capital Projects fund to replace older structures that were at end of life and needed to be removed. Pricing comes from the 1Government Procurement Alliance (1GPA) purchasing cooperative, which fulfills the Board's bid obligation, and includes an additional 3% contingency for any unforeseen issues occurring during installation.

BUDGETARY INFORMATION:

Capital Projects

RESOURCE PERSONNEL:

Phillip Francis, Assistant Superintendent of District Services

EXHIBITS:

Attached

PF/ko



Kidstuff Playsystems

"Your Best Playground Value"



Livonia Public Schools
 Webster Elementary 2023 - Special Needs Center
 1GPA - Playground Solutions #23-07P-06

Kennedy Recreation



P.O./Quote No: 1262023-JFK1
 Proposal Date: 1/26/2023
 Sales Rep: JFK
 Sales Rep Phone #: 586-228-9390
 Sales Rep Email: JFKLU58@yahoo.com

All Purchase orders/Contracts and Checks in care of:
Kennedy Recreation
 19683 Tanglewood Circle
 Clinton Twp MI 48038
 1GPA #23-07P-06

Customer Information:

Bill To:

Ship To:

Name: Livonia Public Schools	Name: Webster Elementary Wayne
Address: 15125 Farmington RD	Address: 32401 Pembroke ST
Address: Livonia, MI 48154	Address: Livonia, MI 48152
Contact: Harry Lau	Contact: Harry Lau
Phone: 734-812-8597	Phone: 734-812-8597
Tax ID #:	Fax:

We are pleased to present a quotation for the items and services, as listed:

Qty	Product #s	Description / Colors	Unit Cost	Unit Freight	Unit Installation	Total
PLAYGROUND & SITE FURNISHINGS ITEMS						
Risk Management Sign						
1	67107	Safety Sign	\$1,292.00			\$1,292.00
1	89603	Three Throw	\$1,776.00			\$1,776.00
1	71601	Music Wall	\$4,513.00			\$4,513.00
1	7141-02	Playsystem 5-12 yrs	\$65,516.00			\$65,516.00
		3.5" Post System with ADA Transfer Station				
		Hex Decks with Roofs				
		Overhead Ladder, Turning Bar and Crunch Bar				
		360 Sprial Slide, Double Slide				
		Clatter Bridge				
		4 ADA Ground level events				
Swings						
1	41102	4' Diameter ADA Basket/Net Swing for 3 Children	\$5,429.00			\$5,429.00
1	Custom	8' tall 3.5" Arch Swings	\$12,826.00			\$12,826.00
		4 Full ADA Swings				
		6 Belt Seats				
120		Border Timber 4' with Stake	\$57.00		\$14.00	\$8,520.00
3		Accessible Wheelchair Ramp	\$575.00		\$65.00	\$1,920.00
1	Freight	Shipping from Indiana	\$3,187.00			\$3,187.00
1	Install	CPSI Installation	\$36,338.00			\$36,338.00
Recommended Additions						
1	R20C4836	3' x 4' Slide Mat	\$132.00		\$50.00	\$182.00
11	R20C4872	4' x 6' Dbl Slide/Swing Mat	\$225.00		\$75.00	\$300.00
1	R20OCT48	8' x 8' Tire Swing/Tuffit Swing Mat	\$863.00		\$200.00	\$1,063.00
1	Freight	Shipping from IN	\$1,588.00			\$1,588.00
SITE PREP: ' x ' = 3744 ' SQ PLAY AREA						
1.5	2700' Roll	Geotex Felt - 1 Layer	\$770.00	Included	\$220.00	\$1,485.00
200	Cubic Yards	Engineered Wood Fiber 12" Settled	\$38.00		Blown- In	\$7,600.00
Product certified to meet ASTM standards for impact-attenuation & ADA accessibility.						

	Lineal Feet	Barrier Fencing	\$1.00			Fenced
	Storage	Locked Trailer w/Drop-Off & Pick-Up	\$710.00			\$0.00
	Dumpster	Disposal of Packing Materials	\$620.00			USE Schools
	Sanitary	Portable Toilet (1 month)	\$100.00			USE Schools
	Site Restore	Rake/Seed/Straw 6' Perimeter	\$0.55			\$0.00
						Subtotal: \$ 153,535.00
						Less 1GPA 20% and FREE Freight \$ 23,693.00
						Net Total: \$ 129,842.00
						Sales Tax: \$ -
						Grand Total: \$ 129,842.00
Equipment, Materials, Freight, Installation & Sales Tax						

We propose hereby to furnish materials and/or labor, in complete accordance with above specifications
 Note: This proposal may be withdrawn by us, if not accepted by: **Month 2/15/2023.**
 for the sum of **ONE HUNDRED TWENTY THREE THOUSAND EIGHT HUNDRED FORTY TWO DOLLARS.**



All Purchase orders/Contracts and Checks in care of:
Kennedy Recreation
19683 Tanglewood Circle
Clinton Twp MI 48038
1GPA #23-07P-06

Acceptance of Proposal: The above prices, specifications and conditions are satisfactory and are hereby accepted. You are authorized to do the work as specified. Payment will be as outlined below. Past due accounts subject to 1 1/2% month charge and legal fees associated with collection.

Customer is responsible for unloading, counting & properly signing the bill of lading when equipment is delivered. Customer is responsible for storage until installation.
 All material is guaranteed to be as specified.
 All work to be completed in a workman-like manner, according to standard practices.
 Any alteration or deviation from the above specifications involving extra cost will be done only upon written orders, and will become an extra charge over and above the estimate.
 All agreements contingent upon strikes, accidents or delays beyond our control.
 Owner to carry fire, tornado and other necessary insurance.
 Our workers are fully covered by Workers Compensation Insurance.

Terms & Conditions: Terms are 50% deposit on equipment with order. Payment is due upon completion.

Signature: _____
 Customer

Printed Name: _____
 Customer

Sales Rep: Jamie Kennedy
 Authorized Signature - Kennedy recreation Inc.

- Notes:
1. Equipment prices include freight and installation charges in lump sum prices.
 2. Full Installation includes concrete blocks and cement for all footings.
 Community Build prices DO NOT INCLUDE MATERIALS FOR FOOTINGS, which must be supplied by customer.
 3. Surfacing materials installation is included in lump sum price.
 4. Site restoration is not included, unless specified above.

- NOTES ON DELIVERY, RECEIPT AND STORAGE OF EQUIPMENT UNTIL INSTALLATION:**
1. Storage trailer charge includes receiving shipment and off-loading into storage trailer.
 We recommend that trailer be parked as close to playground site as possible.
 Protect asphalt from damage with blocks or plywood.
 2. If no storage trailer is desired, then customer MUST UNLOAD AND STORE EQUIPMENT.
 3. If receiving goods, sign Bill of Lading, AFTER making sure that all items are received.
 4. You will need several people to unload all items and store them securely until installation.
 5. **If any packages arrive with damages, REFUSE DELIVERY OF THESE ITEMS and note refusal on Bill of Lading.**

**LIVONIA PUBLIC SCHOOLS
BOARD OF EDUCATION MEETING
January 30, 2023**

TOPIC: Approval to Purchase Furniture for Stevenson Community Room

RECOMMENDATION:

Move that the Board of Education of the Livonia Public Schools School District approve the purchase of furniture for the Stevenson High School Community Room from Interior Environments, Novi, Michigan, for a total amount of \$53,136.29.

RATIONALE:

This purchase is for the Stevenson High School Community Room, which is used by Stevenson students, staff, and families, district administration, and other district organizations and groups. Due to the varied groups using it, the district's capital projects fund will be utilized to outfit this space.

BUDGETARY INFORMATION:

Capital Projects

RESOURCE PERSONNEL:

Phillip Francis, Assistant Superintendent of District Services

EXHIBITS:

Attached

PF/ko



182

STEVENSON COMMUNITY ROOM

PRODUCT & PRICING | 12.23.2022



**interior
environments**



We create workspaces of enduring value that are as unique as our clients.

Process

Team

Service

Our process and delivering the best client experience is every bit as important as our product. We bring value by understanding our customers journey and aligning our process to match your needs. We really get to know you by listening and strategizing. We streamline the design process to bring your vision to life and exceed expectation and deliver results.

Your Dedicated K-12 Team



Bari Pfeiffer
Account Manager

248.635.7908 | bpfeiffer@ieoffices.com



Becky Gusoff
Sr. Project Designer

734.673.0546 | bgusoff@ieoffices.com



Steve Cojei
President - Owner

248.921.1700 | scojei@ieoffices.com



Salina Reynolds
Design Manager

248.996.6229 | sreynolds@ieoffices.com



Katie VanderVeen
Account Manager

708.642.0183 | kvanderveen@ieoffices.com



Lisa Costella
Project Designer

248.301.1972 | lcostella@ieoffices.com



Betsy Pethoud
Field Project Manager

248.996.6270 | bpethoud@ieoffices.com



Alicia Mahone
Project Coordinator

248.305.1942 | amahone@ieoffices.com

Community Room

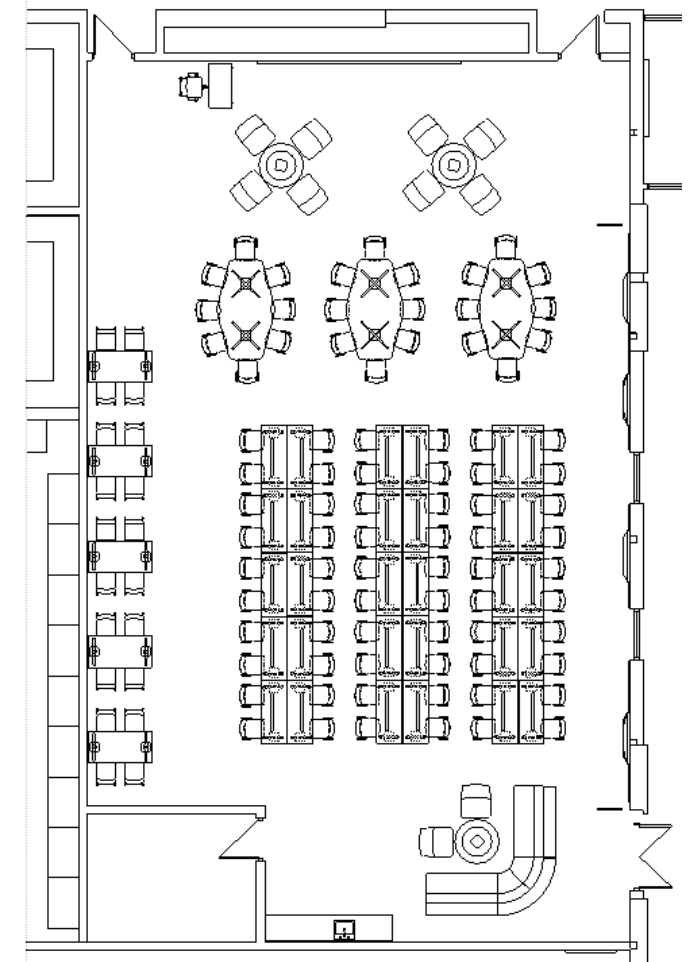
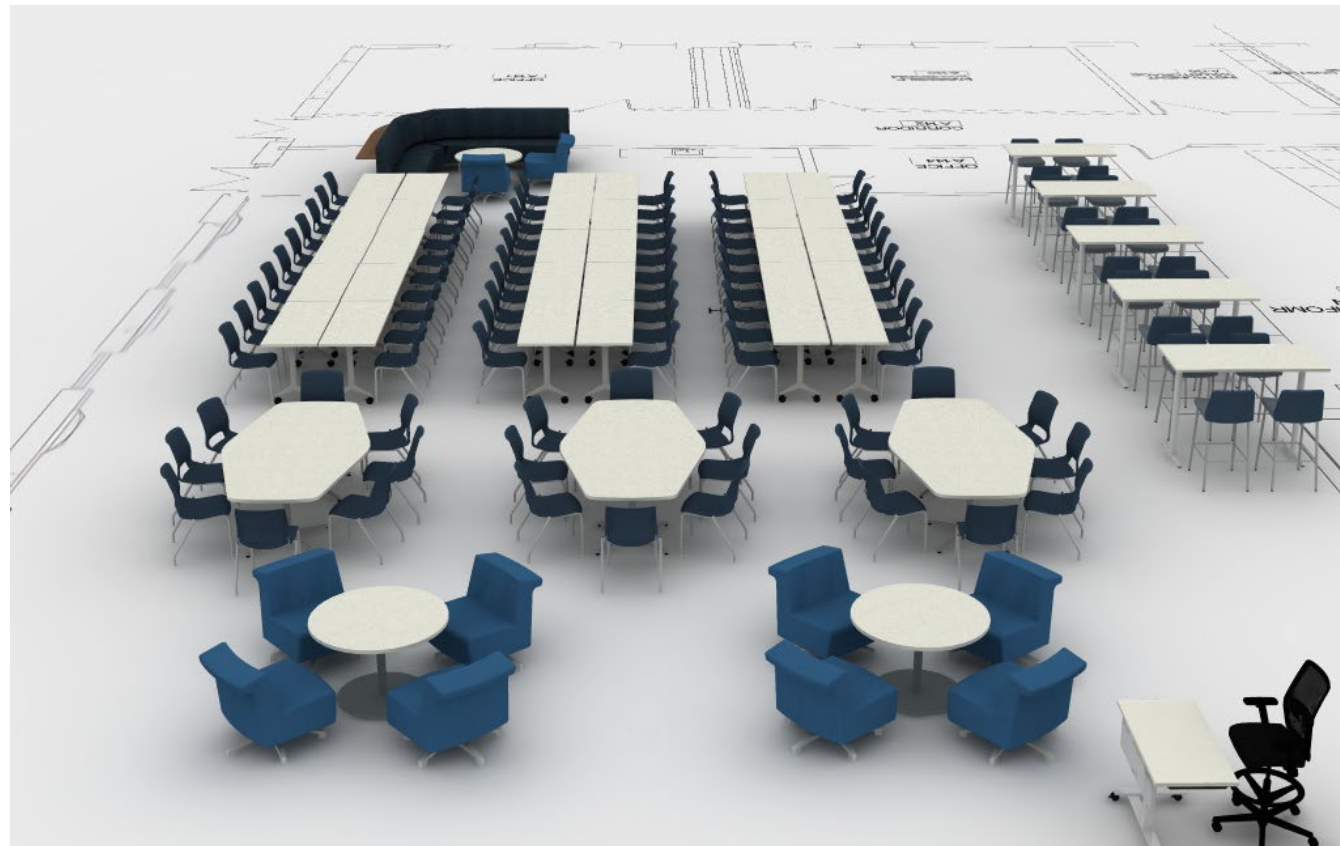

185

INCLUDES:

EXISTING

- OFS COACT LOUNGE SEATING
- (3) ROUND TABLES
- (10) LINGER LOUNGE CHAIRS

NEW

- (3) 54"X96" ALLSTEEL STRUCTURE DIAMOND TOP CONFERENCE TABLE WITH X BASE
- (5) 30"X60" HON ARRANGE CAFÉ HEIGHT TABLE WITH T LEGS
- (30) 24"X60" ALLSTEEL AWARE TABLE WITH FIXED T LEGS
- (1) HEIGHT ADJUSTABLE LAYER TEACHER'S DESK
- (84) HON MOTIVATE 4-LEG STACK CHAIRS
- (20) HON FLOCK 4-LEG STOOL
- (1) HON IGNITION STOOL

Conference Tables



*ALLSTEEL - STRUCTURE
54"X96"DIAMOND TABLES
X BASE*

*HON - MOTIVATE 4 LEG CHAIR
18" SEAT HEIGHT
POLY SHELL WITH GLIDES*

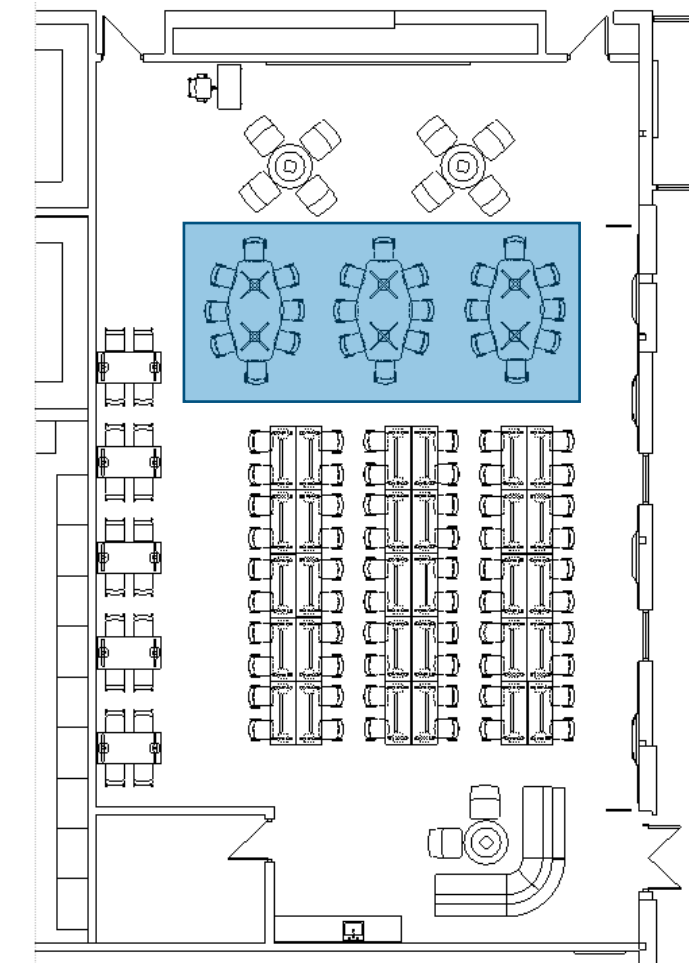

186

LAMINATE

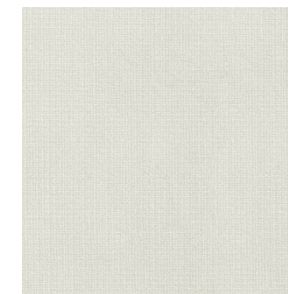

SILVER MESH

LAMINATE



LOFT

PAINT

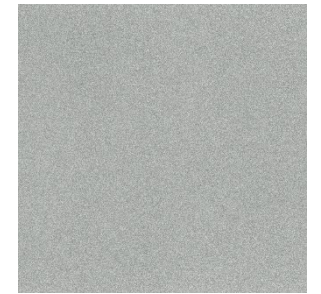

TEXTURED SILVER

CHAIR SHELL



REGATTA

PAINT

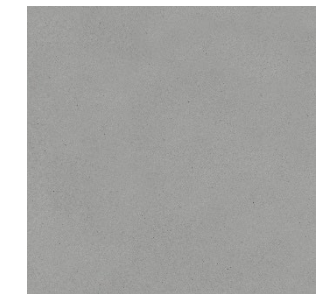

PLATINUM METALLIC

Standard Height Tables



*ALLSTEEL - AWARE
24"X60" RECTANGLE TABLES
T LEGS*

*HON – MOTIVATE 4 LEG CHAIR
18" SEAT HEIGHT
POLY SHELL WITH GLIDES*

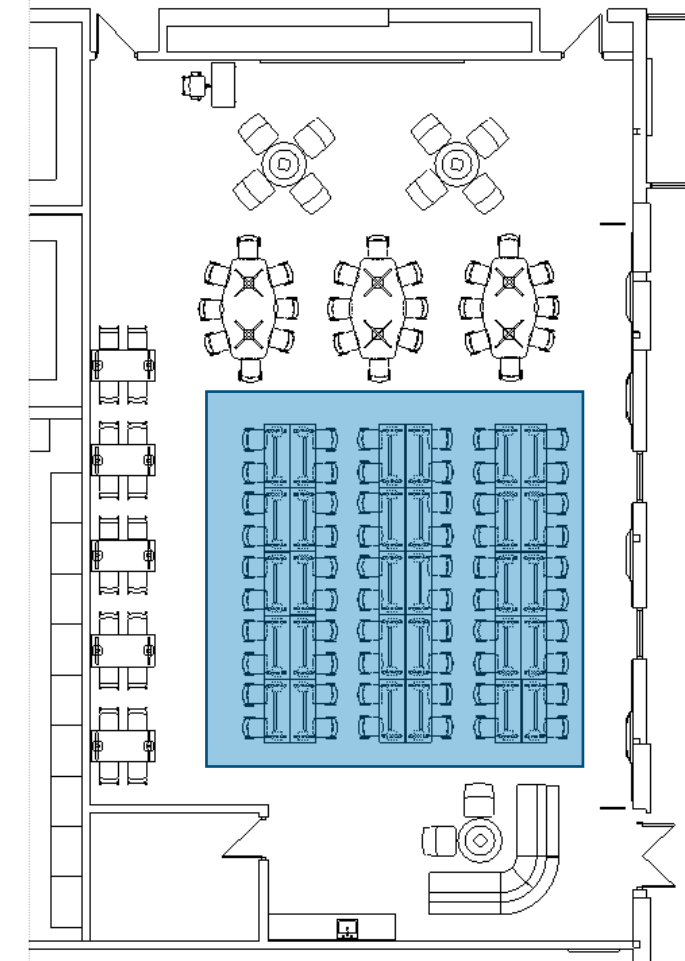

187

LAMINATE

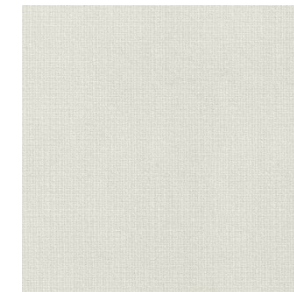

SILVER MESH

LAMINATE

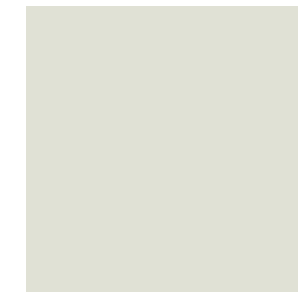

LOFT

PAINT

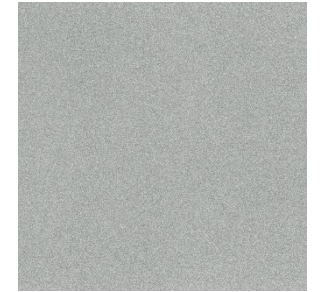

TEXTURED SILVER

CHAIR SHELL



REGATTA

PAINT

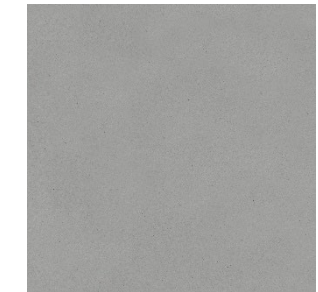

PLATINUM METALLIC

Café Height Tables



*HON - ARRANGE
30"X60" RECTANGLE TABLES
CAFÉ HEIGHT T LEGS*

*HON - FLOCK DUAL FABRIC 4 LEG STOOL
BAR HEIGHT*

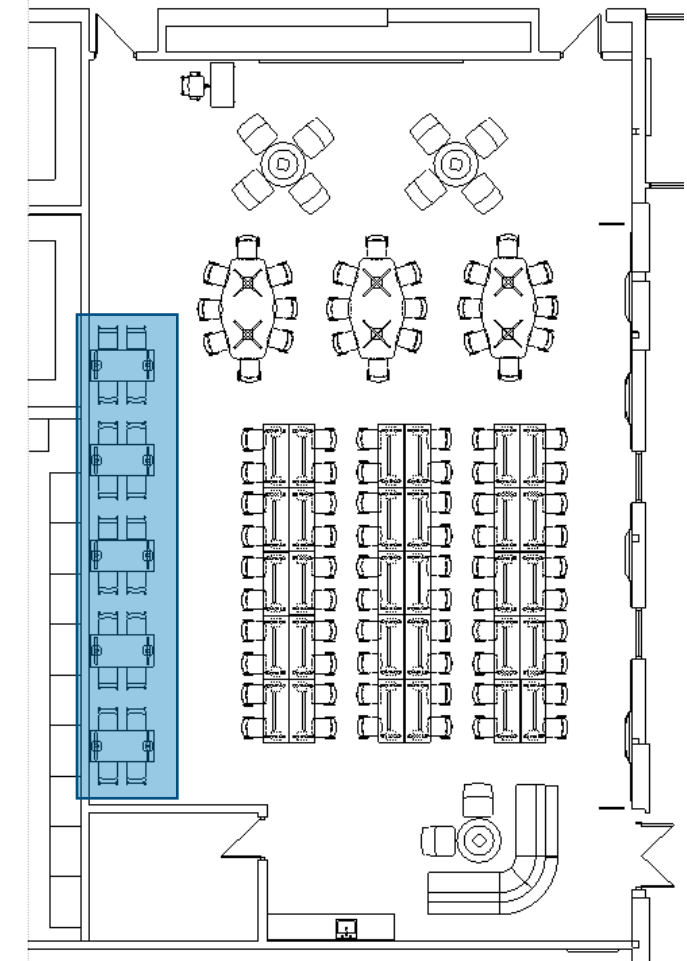

LAMINATE

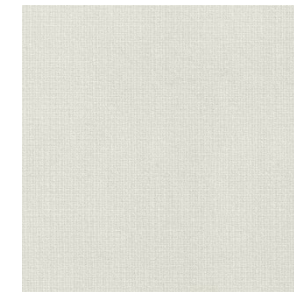

SILVER MESH

LAMINATE

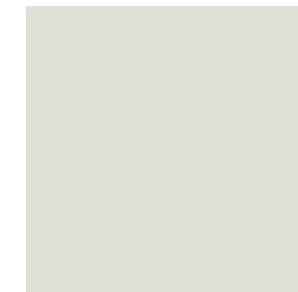

LOFT

PAINT

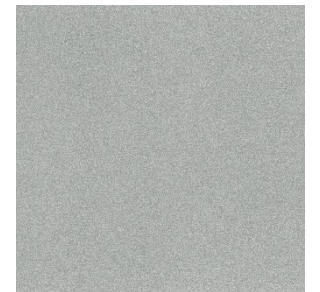

TEXTURED SILVER

SEATING FABRIC

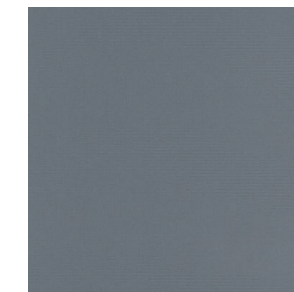

MOXIE, RIVERSTONE

SEATING FABRIC

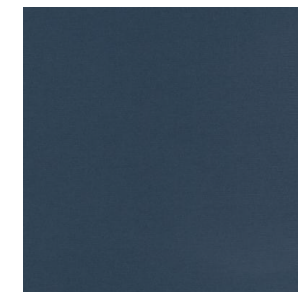

MOXIE, BLUEBERRY

PAINT

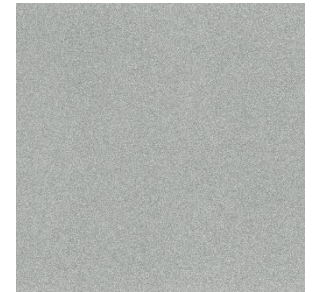

TEXTURED SILVER

Teacher's Station



*OFS – LAYER HEIGHT ADJUSTABLE TEACHER'S DESK
21"X42" DESK
CAFÉ HEIGHT T LEGS*

*HON – IGNITION 2 TASK STOOL
LIMITED SYNCHRO-TILT
HEIGHT AND WIDTH ADJUSTABLE ARMS
ALL SURFACE CASTERS*

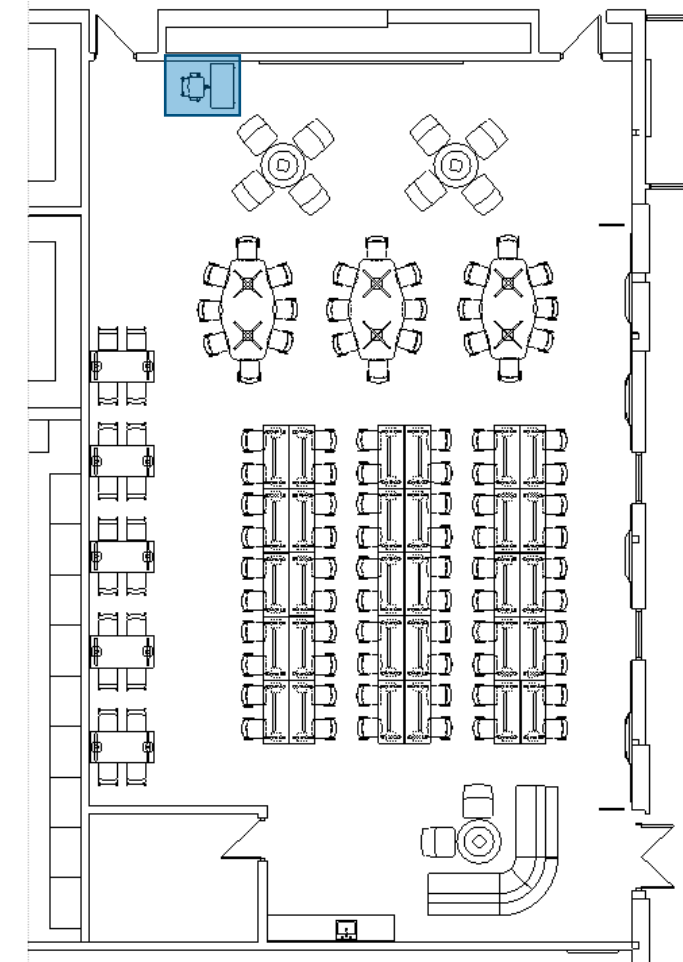

LAMINATE

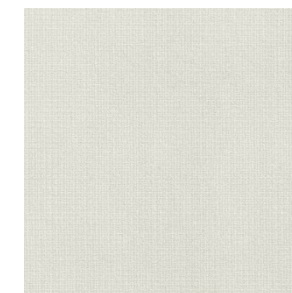

SILVER MESH

EDGE LAMINATE

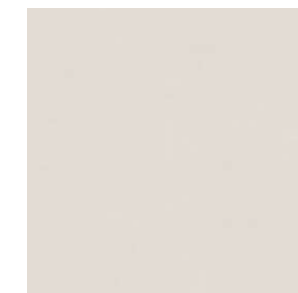

OFS GREY

PAINT

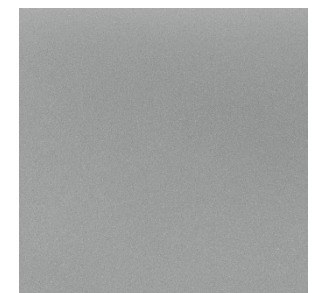

SILVER

Teacher's Station

Livonia Public Schools
Stevenson Community Room



DESCRIPTION	QTY	UNIT PRICING	EXTENDED PRICING
Tables			
Allsteel Structure 54" x 96" Diamond Top with X Bases	3	\$ 1,097.49	\$ 3,292.47
Allsteel Aware standard height table 24" x 60" T Legs with casters	30	\$ 463.05	\$ 13,891.50
Hon Arrange café height table 30"x 60" T Legs	5	\$ 712.35	\$ 3,561.75
Seating			
Hon Motivate 4 leg chair - poly shell with glides - Set of 2	42	\$ 248.93	\$ 10,455.06
Hon Flock Upholstered 4 Leg stool	20	\$ 505.35	\$ 10,107.00
Hon Ignition 2.0 Task Stool	1	\$ 320.84	\$ 320.84
Teacher Desk			
OFS 21" x 42"	1	\$ 1,459.22	\$ 1,459.22
Sub-Total:			\$ 43,087.84
FURNITURE SUB-TOTAL			\$ 43,087.84
CONTINGENCY			\$ 4,308.78
FREIGHT			\$ 1,000.00
INSTALLATION (NON-UNION)			\$ 4,739.66
GRAND TOTAL			\$ 53,136.29

190

PRICING IS BUDGETARY AND WILL BE ADJUSTED BASED ON FINAL DESIGN, FINISH SELECTIONS AND QUANTITIES

10% CONTINGENCY FOR FINISHES & UPGRADES

Create space.

**LIVONIA PUBLIC SCHOOLS
BOARD OF EDUCATION MEETING
January 30, 2023**

TOPIC: Recommend Expulsion of One Secondary Student

RECOMMENDATION:

Move that the Board of Education of the Livonia Public Schools School District expel one high school student for violations of the Livonia Public Schools' Board of Education policies.

RATIONALE:

A disciplinary hearing was held on January 17, 2023, and the Hearing Officer has ruled to expel the student. The timeline for an appeal of this decision has passed without a request.

BUDGETARY INFORMATION:

None

RESOURCE PERSONNEL:

Kevin Etue, Director of Secondary Programs and District Services

EXHIBITS:

None

**LIVONIA PUBLIC SCHOOLS
BOARD OF EDUCATION MEETING
January 30, 2023**

TOPIC: **Approval of Teachers**

RECOMMENDATION:

Move that the Board of Education of the Livonia Public Schools School District accept the recommendation of the superintendent and offer employment for the 2022-23 school year to the teachers listed on the attached document.

RATIONALE:

These teachers have been interviewed, along with many other applicants, for the vacancies that existed in our instructional program. We believe these teachers are the most qualified for the positions and recommend they be approved for employment.

BUDGETARY INFORMATION:

The positions listed are within the 2022-23 budget.

RESOURCE PERSONNEL:

Anthony Abbate, Director of Human Resources
Jennifer Keatts, Director of Human Resources

EXHIBIT:

Attached

ljn

**2022-2023 School Year
New Teachers for Board of Education Approval
1/26/2023**

NAME	DEGREE/SCHOOL	FTE	ASSIGNMENT	MOST RECENT EXPERIENCE	TOTAL YEARS OF EXPERIENCE	STEP
Dardini, McKenna	Bachelor of Science in Elementary Cognitive Impairment Eastern Michigan University	(1.0)	Teacher Frost Middle School January 9, 2023	Frost Middle School Cooper Elementary School Student Teacher	6 months	Step 0 (BS) 5 years probation
Dunn, Allyson	Master of Arts Teaching Educational Technology Madonna University Bachelor of Arts in History Madonna University	(1.0)	Teacher Cooper Elementary School December 19, 2022	Warrendale Charter Academy Middle School Social Studies Teacher	12.5 years	Step 7 (MA) 5 years probation 194
Hurley, Thomas	Master of Education Bilingual-Bicultural Education Wayne State University Bachelor of Arts in Interdisciplinary Studies: Social Science Education Michigan State University	(1.0)	Social Studies Teacher Franklin High School January 26, 2023	Crestwood High School Social Studies Teacher	8 years	Step 8 (M.Ed.) 2 years probation
Kefallinos, Yanni	Bachelor of Arts in Social Studies History Eastern Michigan University	(1.0)	Social Studies Teacher Stevenson High School (.8) Franklin High School (.2) January 30, 2023	Fordson High School Student Teacher	6 months	Step 0 (BA) 5 years probation

**LIVONIA PUBLIC SCHOOLS
BOARD OF EDUCATION MEETING
January 30, 2023**

TOPIC: Granting of Tenure Status to Specified Teachers

RECOMMENDATION:

Move that the Board of Education of the Livonia Public Schools School District accept the recommendation of the superintendent and acknowledge that tenure status has been granted to the following teachers, effective on the respective date:

<u>Name</u>	<u>Date</u>
Kelly Billin	November 22, 2021
Alison Boike	January 26, 2023
Brittany Cornellier	January 10, 2023
Gillian Drutchas	January 29, 2023
Erin Horback	January 29, 2023

RATIONALE :

These teachers have successfully completed the District's requirements for probationary teachers including years of service, evaluations, and overall performance, as well as student growth. We have carefully reviewed all of the supporting documents and based upon our review, as well as the recommendations of building principals, these individuals have achieved tenure status with the Livonia Public Schools.

RESOURCE PERSONNEL:

Jennifer Keatts, Director of Human Resources
Anthony Abbate, Director of Human Resources

EXHIBIT:

None

**LIVONIA PUBLIC SCHOOLS
BOARD OF EDUCATION MEETING
January 30, 2023**

TOPIC: **Leave of Absence**

RECOMMENDATION:

Move that the Board of Education of the Livonia Public Schools School District accept the recommendation of the superintendent and approve the request for a leave of absence as listed below:

<u>Name</u>	<u>Date Effective</u>
Alison Frazier	January 17, 2023

BUDGETARY INFORMATION:

None

RESOURCE PERSONNEL:

Anthony Abbate, Director of Human Resources
Jennifer Keatts, Director of Human Resources

EXHIBIT:

None

**LIVONIA PUBLIC SCHOOLS
BOARD OF EDUCATION MEETING
January 30, 2023**

TOPIC: **Resignation**

RECOMMENDATION:

As authorized in the Board of Education motion of June 13, 2022, the following resignation has been accepted by the superintendent:

<u>Name</u>	<u>Date Effective</u>
Kimberly Zarzycki	January 20, 2023

BUDGETARY INFORMATION:

None

RESOURCE PERSONNEL:

Jennifer Keatts, Director of Human Resources
Anthony Abbate, Director of Human Resources

EXHIBIT:

None

**LIVONIA PUBLIC SCHOOLS
BOARD OF EDUCATION MEETING
January 30, 2023**

TOPIC: Resolution of Appreciation for Employees Who are Retiring

RECOMMENDATION:

Move that the Board of Education of the Livonia Public Schools School District adopt the attached resolutions of appreciation for services rendered by:

**Janet Cronin
Joan McCloskey
Rossann Padgen**

BUDGETARY INFORMATION:

None

RESOURCE PERSONNEL:

Jennifer Keatts, Director of Human Resources
Anthony Abbate, Director of Human Resources

EXHIBIT:

Attached resolution

**LIVONIA PUBLIC SCHOOLS
BOARD OF EDUCATION MEETING
January 30, 2023**

RESOLUTION

Janet Cronin

WHEREAS, It has been brought to the attention of the Board of Education of the Livonia Public Schools School District that Janet Cronin retired from the district on December 23, 2022; and,

WHEREAS, Janet Cronin has devoted 15.4 years of dedicated, loyal, and outstanding service to the Livonia Public Schools as a paraprofessional at Western Wayne Skill Center, Webster Elementary, Livonia Career Technical Center, Grant Elementary, Churchill High School and Frost Middle School; and,

WHEREAS, She has given conscientious, careful, and loyal service to the students, staff, and community during her tenure with the Livonia Public Schools;

NOW, THEREFORE, BE IT RESOLVED That the Board of Education does hereby express its deep appreciation to Janet Cronin for her countless contributions to our school system and extends best wishes for an enjoyable and rewarding retirement.

Joan McCloskey

WHEREAS, It has been brought to the attention of the Board of Education of the Livonia Public Schools School District that Joan McCloskey retired from the district on January 13, 2023; and,

WHEREAS, Joan McCloskey has devoted 23.1 years of dedicated, loyal, and outstanding service to the Livonia Public Schools as a bus driver in the Transportation Department; and,

WHEREAS, She has given conscientious, careful, and loyal service to the students, staff, and community during her tenure with the Livonia Public Schools;

NOW, THEREFORE, BE IT RESOLVED That the Board of Education does hereby express its deep appreciation to Joan McCloskey for her countless contributions to our school system and extends best wishes for an enjoyable and rewarding retirement.

Rossann Padgen

WHEREAS, It has been brought to the attention of the Board of Education of the Livonia Public Schools School District that Rossann Padgen retired from the district on January 13, 2023; and,

WHEREAS, Rossann Padgen has devoted 33.5 years of dedicated, loyal, and outstanding service to the Livonia Public Schools as a paraprofessional at Jackson Early Childhood Center, Hoover Elementary, Coolidge Elementary, Grant Elementary, Perrinville Early Childhood Center and Roosevelt Elementary; and,

WHEREAS, She has given conscientious, careful, and loyal service to the students, staff, and community during her tenure with the Livonia Public Schools;

NOW, THEREFORE, BE IT RESOLVED That the Board of Education does hereby express its deep appreciation to Rossann Padgen for her countless contributions to our school system and extends best wishes for an enjoyable and rewarding retirement.

BYLAWS OF THE BOARD

BBABA

BOARD OPERATIONS DUTIES OF THE PRESIDENT

FEBRUARY 24, 2020

The president of the Board shall preside at all regular meetings, special meetings, closed sessions, committee meetings, and study sessions; shall have the option to make and second motions, shall vote on all agenda items unless a conflict of interest exists; shall plan cooperatively with the superintendent the agendas for such meetings; shall represent and speak for the Board when requested to do so and only on action which the Board has already taken; shall sign documents as required by law and correspondence as authorized by the Board; shall appoint Board members as committee chairpersons and members as soon as feasible following the meeting of the election of officers; shall make other committee appointments; and shall perform such other duties as authorized by the Board.

LEGAL REF.: MCL 380.11a(6)

**LIVONIA PUBLIC SCHOOLS
BOARD OF EDUCATION MEETING
January 30, 2023**

TOPIC: First Reading of Board Policy

RECOMMENDATION:

The Policy Committee has reviewed the proposed policy:

- **Board Policy JI – Students, Pledge of Allegiance**

RATIONALE:

This is the first reading for this policy and is provided for Board review and possible adoption at a future meeting.

BUDGETARY INFORMATION:

None

RESOURCE PERSONNEL:

Andrea Oquist, Superintendent

EXHIBITS:

Attached

Off/Supt/jw

BOARD POLICY

JI

STUDENTS PLEDGE OF ALLEGIANCE

DATE

In accordance with the Revised School Code, the opportunity to recite the pledge of allegiance to the flag of the United States will be offered each school day to all students. A student will not be compelled, against the student's objection or the objection of the student's parent or legal guardian, to recite the pledge of allegiance. A student will not be subject to any penalty or retaliation at school for not reciting the pledge of allegiance.

LEGAL REF.: MCL 380.1347a

**LIVONIA PUBLIC SCHOOLS
BOARD OF EDUCATION MEETING
January 30, 2023**

TOPIC: **Second Reading & Adoption of Board Policies**

RECOMMENDATION:

Move that the Board of Education of the Livonia Public Schools School District accept the recommendation of the Policy Committee and adopt Board Policy language per the attached documents for the following policies:

INSTRUCTIONAL PROGRAM

- **IDDA - Special Education Programs**
- **IDDD - Programs for the Academically Talented**
- **II - Systemwide Assessment Program**
- **IIA - Testing Programs (Removal of Policy)**
- **IIC - Use and Dissemination of Assessment Results**

RATIONALE:

The Board Policy Committee has met with staff to review proposed language for the above policies and is recommending approval by the entire Board. This language was submitted for first reading at the Board meeting of December 12, 2022.

BUDGETARY INFORMATION:

None

RESOURCE PERSONNEL:

Theresa O'Brien, Chief Academic Officer

EXHIBITS:

Attached Policies

Off/Supt/jw

BOARD POLICY

IDDA

INSTRUCTIONAL PROGRAM SPECIAL EDUCATION PROGRAMS

JANUARY 30, 2023

The School District will provide eligible students with Individualized Education Plans (IEP) programming and services to meet their needs. These programs and services will be coordinated by the Department of Student Services and its staff. The District will abide by all applicable laws, including State and Federal laws such as Michigan Administrative Rules for Special Education (MARSE) and Individuals with Disability Education Act (IDEA).

LEGAL REF.: 20 USC 1400 *et seq.*; 34 CFR Part 300; 29 USC 705(20), 794-794b; 34 CFR Part 104; MCL 380.4 *et seq.* 380.1311; 380.1703; 380.1751 to 380.1766; 388.1009a; 388.1651a, 388.1652; 388.1653a; 388.1654; 388.1656; R340.1701 *et seq.*

BOARD POLICY

IDDA

INSTRUCTIONAL PROGRAM SPECIAL EDUCATION PROGRAMS

MARCH 16, 2015

~~The Board of Education provides special programs and services to meet the needs of its students with special needs. These programs and services will be coordinated by the Department of Student Services, which interprets and operates these services according to law.~~

The School District will provide eligible students with Individualized Education Plans (IEP) programming and services to meet their needs. These programs and services will be coordinated by the Department of Student Services and its staff. The District will abide by all applicable laws, including State and Federal laws such as Michigan Administrative Rules for Special Education (MARSE) and Individuals with Disability Education Act (IDEA).

LEGAL REF.: 20 USC 1400 *et seq.*; 34 CFR Part 300; 29 USC 705(20), 794-794b; 34 CFR Part 104;
MCL, 380.4 *et seq.* 380.1311; 380.1703; 380.1751 to 380.1766; 388.1009a; 388.1651a, 388.1652; 388.1653a; 388.1654; 388.1656; R340.1701 *et seq.*

BOARD POLICY

IDDD

INSTRUCTIONAL PROGRAM PROGRAMS FOR THE ACADEMICALLY TALENTED

JANUARY 30, 2023

The School District will provide academically talented students access to learning opportunities both in general education classrooms and in magnet programs, to meet their needs. These programs and services will be coordinated by the directors of elementary and secondary education with the support of the Academic Services Department.

Staff may conduct studies and research to ascertain appropriate curricular and instructional opportunities and programming for academically talented students.

BOARD POLICY

IDDD

INSTRUCTIONAL PROGRAM PROGRAMS FOR THE GIFTED **ACADEMICALLY TALENTED**

~~JUNE 20, 1988~~

~~The Board of Education shall encourage the staff to seek out those organizational arrangements, teaching methods and other instructional provisions for providing the appropriate learning and development of all academically talented and otherwise gifted students. To this end, pilot programs may be established, and studies and research conducted to ascertain appropriate curricular and instructional means for accomplishing the above objective.~~

The School District will provide academically talented students access to learning opportunities both in general education classrooms and in magnet programs, to meet their needs. These programs and services will be coordinated by the directors of elementary and secondary education with the support of the Academic Services Department.

Staff may conduct studies and research to ascertain appropriate curricular and instructional opportunities and programming for academically talented students.

BOARD POLICY

II

INSTRUCTIONAL PROGRAM SYSTEMWIDE ASSESSMENT PROGRAM

JANUARY 30, 2023

The purpose of the systemwide assessment program is to plan appropriate instructional activities for each student in addition to providing the School District and each school essential information on the growth and achievement of our learners.

The School District will select and administer a series of aptitude, diagnostic and standardized achievement assessments, which provide information related to a student's learning potential as well as longitudinal achievement data on individual learners and cohorts of students in the District. Other appropriate assessments may be used for diagnostic purposes.

The School District shall assess learning based on the current standards and curriculum being used in classrooms across the District. This includes, but is not limited to, school improvement assessments, common course and grade level assessments, and unit tests. These assessments, along with standardized assessments, provide a broader picture of a student's abilities and attainment of standards. In addition, surveys and student focus groups provide a "picture" of students' thoughts, feelings and attitudes.

BOARD POLICY

IIA

INSTRUCTIONAL PROGRAM TESTING PROGRAMS

JUNE 20, 1988

The Board of Education expects the staff to select and administer a series of mental capacity tests and standardized achievement tests, particularly in the areas of the so-called basic skills and study skills, as one source of data indicating the nature of the students' potential and of their longitudinal achievement as they progress through the schools. Other appropriate tests may be used on an optional basis for diagnostic purposes.

Although it is the general attitude of this Board that reasonable limits should be placed on the administering of tests to students, it is permissible to administer selected so-called external tests to those students desiring to take the same for college entrance, scholarships, academic competition, and college placement.

The Board of Education encourages the staff to examine continually the values which reflect the objectives of the School System, the needs of students, and the circumstances in society which indicate the necessity for new or different educational experiences. As a result of such study and reexamination, the staff is further encouraged to seek better means for assessing learning in such areas as the cognitive abilities including inductive thinking, the process of inquiry, critical thinking, and the process of problem-solving. Also, it is expected that assessment means should be found or devised through which data may be gathered regarding learning in the so-called "affective domain," including such factors as feelings, attitudes, and appreciations.

LEGAL REF.: MCL 388.1081*et seq.*; R340.1101 TO R340.1107

BOARD POLICY

IIC

INSTRUCTIONAL PROGRAM USE AND DISSEMINATION OF ASSESSMENT RESULTS

JANUARY 30, 2023-

The District will provide all parents/guardians and students who are over 18, full access to personal educational data. Student records will not be released to a third party without prior written consent of the parent/guardian or student (if over 18), with the exceptions made for Livonia Public Schools staff, governmental educational agencies, or other persons, as provided by law.

LEGAL REF.: 20 USC 1232g *et seq.*

BOARD POLICY

IIC

INSTRUCTIONAL PROGRAM

~~JUNE 20, 1988~~

USE AND DISSEMINATION OF TEST ASSESSMENT RESULTS

~~All parents and students 18 and over have full access to all educational records or data relating to the student. Student records will not be released to a third party without prior written consent of the parents or the student if over 18, with exceptions made for other school officials and governmental education agencies or as otherwise provided by law.~~

The District will provide all parents/guardians and students who are over 18, full access to personal educational data. Student records will not be released to a third party without prior written consent of the parent/guardian or student (if over 18), with the exceptions made for Livonia Public Schools staff, governmental educational agencies, or other persons, as provided by law.

LEGAL REF.: 20 USC 1232g *et seq.*

**LIVONIA PUBLIC SCHOOLS
BOARD OF EDUCATION MEETING
January 30, 2023**

**TOPIC: Approval for Board Members to Participate in
MASB’s Virtual Winter Institute and Take MASB Classes**

RECOMMENDATION:

Move that the Board of Education of the Livonia Public Schools School District approve that Board Trustees Madeline Acosta, Tammy Bonifield, Liz Jarvis, and Mark Johnson participate in MASB’s Virtual Winter Institute February 24-26, 2023, and take MASB classes, for a total cost of \$2,178.

RATIONALE:

Board members are encouraged to attend educational, leadership, and developmental workshops, conferences, and seminars which will assist them in the performance of their duties. Per Board Policy BBBC, expenditures require Board approval.

BUDGETARY INFORMATION:

All within prescribed budget allocations. Some MASB courses qualify for reimbursement from the State of Michigan.

RESOURCE PERSONNEL:

Andrea L. Oquist, Superintendent

EXHIBITS:

None

Off/Supt/jw