

**LIVONIA PUBLIC SCHOOLS
BOARD OF EDUCATION**

**Regular Meeting
September 28, 2020 - 7:00 PM
Board Room
15125 Farmington Road
Livonia, Michigan 48154**

AGENDA

- I. ROLL CALL: Tammy Bonifield, Karen Bradford, Colleen Burton,
Dan Centers, Crystal Frank, Liz Jarvis, Mark Johnson**
- II. PLEDGE OF ALLEGIANCE**
- III. COMMUNICATIONS**
 - A. Recognition of Board Members for MASB Awards**
 - B. District Update from the Superintendent**
 - C. Written Communications**
 - D. Audience Communications (limited to 15 minutes, with remainder
following Personnel Matters)**
 - E. Response to Prior Audience Communications**
- IV. CONSENT AGENDA--Items marked with an "*" will be considered in one
motion. These routine items have been individually reviewed by Board
committees and were unanimously recommended for placing on this
consent agenda. Any member of the Board may remove items from the
consent agenda prior to voting.**
- V. DISPOSITION OF MINUTES**
 - A. *Minutes of the Regular Meeting of August 17, 2020**
- VI. INSTRUCTION MATTERS**
 - A. Approval of Extended COVID-19 Continuity of Learning Plan**
 - B. Approval to Purchase i-Ready Instructional Licenses**
 - C. Approval to Purchase Program Supplies - State Grant**
- VII. BUSINESS MATTERS**
 - A. Approval of Resolution for Bond Refinancing**
 - B. *Approval to Purchase Bulk Salt**
 - C. *Approval of Waste Removal Contract Extension**
 - D. *Approval to Purchase Pizza for School Meal Program**
 - E. *Approval to Purchase Dairy Products for School Meal Program**
 - F. Approval of School Meal Program Vendor**
 - G. Approval to Purchase Technology for School Meal Program**
 - H. Approval to Purchase Thermal Monitoring and Control Systems**
 - I. Approval to Purchase Plexiglass**
 - J. Approval to Purchase Folding Chairs & Storage Dollies - 2013 Bond**
 - K. Approval to Purchase Choral Risers - 2013 Bond**
- VIII. PERSONNEL MATTERS**
 - A. Teachers for Approval**
 - B. Teachers for Tenure**

- C. Leaves of Absence**
- D. Resignations**
- E. Retirements**
- IX. HEARING FROM BOARD MEMBERS**
- X. ADJOURNMENT**

**LIVONIA PUBLIC SCHOOLS
BOARD OF EDUCATION MEETING
September 28, 2020**

TOPIC: Consent Agenda

RECOMMENDATION:

Move that the Board of Education of the Livonia Public Schools School District approve the following consent agenda items, as recommended by the superintendent:

- V.A. Minutes of the Regular Meeting of August 17, 2020
- VII.B. Approval to Purchase Bulk Salt
- VII.C. Approval of Waste Removal Contract Extension
- VII.D. Approval to Purchase Pizza for School Meal Program
- VII.E. Approval to Purchase Dairy Products for School Meal Program

RATIONALE:

The agenda for the Board of Education meeting has certain items designated and identified by an asterisk *. These items, identified in advance with concurrence of the Board President, will be acted upon in a single motion.

BUDGETARY INFORMATION:

None

RESOURCE PERSONNEL:

Andrea L. Oquist, Superintendent

EXHIBITS:

Attached
Off/Supt/jw

**MINUTES
BOARD OF EDUCATION
Livonia Public Schools
15125 Farmington Road
VIRTUAL Regular Meeting
August 17, 2020**

President Johnson convened the virtual meeting at 7:23 p.m. This meeting was held in compliance with the Stay-Home, Stay-Safe Executive Order. In addition, Executive Order 2020-154 temporarily authorizes a public meeting to be held remotely.

Members Present

Bonifield, Bradford, Burton, Centers, Frank, Jarvis, Johnson

Members Absent

None

Written Communication

None

Audience Communication

Communications were received from two individuals regarding the *Return to Learn* plan and were read aloud by Stacy Jenkins, administrator of communications.

Response to Prior Audience Communication

None

District Update from the Superintendent

Superintendent Oquist shared that on the day following the August 10 Regular meeting (when the Board approved the District's Return to Learn (RTL) plan), communication was sent to families with a summary of the RTL plan and an FAQ. A link to the Wayne County Health Department manual will be provided on the District's website, and PPE procurement and distribution continues.

Consent Agenda

It was moved by Mrs. Frank and supported by Mrs. Jarvis that the Board of Education of the Livonia Public Schools School District approve the following consent agenda items, as recommended by the superintendent:

- V.A. Minutes of the Regular Meeting of July 27, 2020
- V.B. Minutes of the Organizational Meeting of July 27, 2020
- V.C. Minutes of the Special Meeting of August 3, 2020
- V.D. Minutes of the Special Meeting of August 10, 2020
- VI.A. Approval of 2020-2021 Tuition Rate (\$10,947.00 for nonresident students for 2020-21)

VI.B. Purchase of Copy Paper for 2020-2021
(\$103,872.42 from Contract Paper Company)

Ayes: Bonifield, Bradford, Burton, Centers, Frank, Jarvis, Johnson
Nays: None

**Refunding of
Prior Bonds**

It was moved by Mr. Centers and supported by Mrs. Bradford that the Board of Education of the Livonia Public Schools School District approve a resolution to ratify the refunding of the 2013 Bonds, Series I and 2014 Refunding Bonds.

Ayes: Bonifield, Bradford, Burton, Centers, Frank, Jarvis, Johnson
Nays: None

**Purchase of
Data Center
Hardware**

It was moved Mrs. Jarvis and supported by Mrs. Frank that the Board of Education of the Livonia Public Schools School District approve the purchase of data center hardware and services from CDW-G, Vernon Hills, Illinois in the amount of \$296,650.47.

Ayes: Bonifield, Bradford, Burton, Centers, Frank, Jarvis, Johnson
Nays: None

**Purchase of
Carts and
Laptops**

It was moved by Mrs. Bonifield and supported by Mr. Centers that that the Board of Education of the Livonia Public Schools School District approve the purchase of laptop computers and charging carts from CDW-G, Vernon Hills, Illinois in the amount of \$153,306.00.

Ayes: Bonifield, Bradford, Burton, Centers, Frank, Jarvis, Johnson
Nays: None

**Purchase of
Personal
Protective
Equipment**

It was moved by Mrs. Burton and supported by Mrs. Bradford that the Board of Education of the Livonia Public Schools School District approve the purchase of Personal Protective Equipment from Ferguson Facilities Supply, Belleville, Michigan in the amount of \$54,650.00 and School Specialty, Chicago, Illinois in the amount of \$122,296.00 for a total purchase price of \$176,946.00.

Ayes: Bonifield, Bradford, Burton, Centers, Frank, Jarvis, Johnson
Nays: None

**Purchase of
Furniture for Art
Classrooms –
2013 Bond**

It was moved by Mrs. Bradford and supported by Mrs. Burton that the Board of Education of the Livonia Public Schools School District approve the purchase of elementary art room furniture from Interior Environments, Novi, Michigan in the amount of \$41,753.18 and Smith Systems, Plano, Texas in the amount of \$94,820.25 for a

total purchase price of \$136,573.43.

Ayes: Bonifield, Bradford, Burton, Centers, Frank, Jarvis, Johnson
Nays: None

**Purchase of
Technology for
Special
Education –
ACT 18**

It was moved by Mr. Centers and supported by Mrs. Jarvis that the Board of Education of the Livonia Public Schools School District approve the purchase of technology for Special Education students and staff, utilizing ACT 18 funds, for a total amount of \$96,509.65.

Ayes: Bonifield, Bradford, Burton, Centers, Frank, Jarvis, Johnson
Nays: None

**Approval of
Teachers**

It was moved by Mrs. Frank and supported by Mrs. Bradford that the Board of Education of the Livonia Public Schools School District accept the recommendation of the superintendent and offer employment for the 2020-21 school year to the following teachers:

<u>Name</u>	<u>Location</u>	<u>Date Effective</u>
Linde Guenther	1.0 Cleveland Elementary	8/31/2020
Kristen Jones	1.0 Student Services (Psychologist)	8/31/2020
Claire Matthews	1.0 Roosevelt Elementary	8/31/2020
Asako Okano	0.6 Niji-Iro (Japanese)	8/11/2020
Gabrielle Popp	1.0 Student Services (VI)	8/31/2020
Chelsea Wilk	1.0 Jackson Center (Young 5's)	8/31/2020

Ayes: Bonifield, Bradford, Burton, Centers, Frank, Jarvis, Johnson
Nays: None

**Recall of
Teachers**

It was moved by Mrs. Jarvis and supported by Mrs. Burton that the Board of Education accept the recommendation of the superintendent and recall to the district employment as a teacher for the 2020-21 school year:

<u>Name</u>	<u>Assignment</u>
Josephine Luna	.58 Shared Time Teacher
Zachary Seasock	1.0 Social Studies, Holmes Middle School

Ayes: Bonifield, Bradford, Burton, Centers, Frank, Jarvis, Johnson
Nays: None

**Leaves of
Absence**

It was moved by Mrs. Bonifield and supported by Mrs. Bradford that the Board of Education of the Livonia Public Schools School District accept the recommendation of the superintendent and approve the request for leave of absence as listed below:

<u>Name</u>	<u>Date Effective</u>
Whitney Cabbie	November 20, 2020
Rebecca Gezahegn	August 31, 2020

Ayes: Bonifield, Bradford, Burton, Centers, Frank, Jarvis, Johnson
Nays: None

Resignations

The Board was informed that a resignation was accepted for:

<u>Name</u>	<u>Date Effective</u>
Caitlin Ball	August 6, 2020

Retirements

It was moved by Mr. Centers and supported by Mrs. Burton that the Board of Education of the Livonia Public Schools School District adopt resolutions of appreciation for services rendered by:

Jacqueline Beitz, who will retire from the district on October 31, 2020, and who will have devoted 34.2 years of dedicated, loyal, and outstanding service to the students of Cass Elementary and Jackson Early Childhood Center as an assistant coordinator in the school-aged childcare program, assistant supervisor in the school-aged childcare program, supervisor of the school-aged childcare program and an assistant building administrator.

Kenneth Braun, who retired from the district on June 20, 2020, and devoted 21 years of dedicated, loyal, and outstanding service to the students of Frost Middle School as a teacher.

Debra Glen, who retired from the district on June 30, 2020, and devoted 30 years of dedicated, loyal, and outstanding service to the students of Stevenson High School, Frost Middle School, Churchill High School, and Emerson Middle School as a teacher.

Carol Kelly, who retired from the district on June 5, 2020, and devoted 10.6 years of dedicated, loyal, and outstanding service to the Livonia Public Schools as an associate teacher in the Great Start Readiness Program.

Gail Wilhelm-Liles, who retired from the district on June 12, 2020, and devoted 27 years of dedicated, loyal, and outstanding service to the Livonia Public Schools as a transportation paraprofessional in the Transportation Department.

Ayes: Bonifield, Bradford, Burton, Centers, Frank, Jarvis, Johnson
Nays: None

Second Reading & Adoption of Board Policies

It was moved by Mrs. Burton and supported by Mr. Frank that the Board of Education of the Livonia Public Schools School District accept the recommendation of the Policy Committee and adopt Board Policy language for:

GAAA Personnel / Nondiscrimination Policy

BOARD POLICY

PERSONNEL

NONDISCRIMINATION

It is the policy of the Board of Education that Livonia Public Schools School District will not discriminate against any person on the basis of sex, race, color, national origin, religion, height, weight, marital status, handicap, disability, sexual orientation, sexual identity, or transgender status. The District reaffirms its long-standing policy of compliance with all applicable federal and state laws and regulations prohibiting discrimination including, but not limited to, Titles VI and VII of the Civil Rights Act of 1964, 42 U.S.C. §§ 2000d, et seq., and 42 U.S.C. §§ 2000e, et seq.; Title IX of the

GAAA

August 17, 2020

**GAB
Personnel /
Non-
discriminatory
Employment
Practices**

Educational Amendments of 1972, 20 U.S.C. §§ 1681, et seq., Section 504 of the Rehabilitation Act of 1973, 29 U.S.C. § 794; the Americans with Disabilities Act of 1990, 42 U.S.C §§ 12101, et seq., the Handicappers' Civil Rights Act, MCL §§ 37.1101, et seq.; and the Elliott-Larsen Civil Rights Act, MCL §§ 37.2101, et seq.

The Director of Student Services is appointed the Civil Rights Coordinator regarding complaints of disability/handicap discrimination involving educational services, programs, and activities. The Director of Human Resources is appointed the Civil Rights Coordinator regarding all other complaints of discrimination.

**GAEA
Personnel /
Discriminatory
Harassment of
Employees or
Applicants for
Employment**

The Civil Rights Coordinator is designated to receive and resolve complaints from any person who believes that he/she may have been discriminated against in violation of this policy. Any person who believes he/she has been discriminated against in violation of this policy should file a written complaint with the Civil Rights Coordinator within ten (10) calendar days of the alleged violation. The Civil Rights Coordinator will then take the following action. First, determine whether the complaint concerns allegations of (a) discrimination on the basis of sex in the educational programs and activities which it operates, including employment, admissions, recruitment, referrals, and collective bargaining, or (b) sexual harassment. If the allegations concern either of these matters, then the Civil Rights Coordinator must notify the Title IX Coordinator and the complaint shall be resolved in accordance with the Title IX grievance procedures of Administrative Procedure JAA. Second, commence an investigation of the complaint, if the Title IX grievance procedures are not applicable based upon the conduct alleged. Third, arrange for a meeting to occur with the complainant, which may include School District staff who are knowledgeable of the facts and circumstances of the particular complaint or who have particular expertise which will assist in resolving the complaint. Fourth, complete the investigation of the complaint and provide in writing a reply to the complainant. If the Civil Rights Coordinator determines that a violation has occurred, he/she shall propose a fair resolution of the complaint and deliver the determination to the complainant and the School District's Superintendent. The complainant may appeal the Civil Rights Coordinator's determination to the Superintendent by so notifying the Superintendent in writing within ten (10) calendar days of the Civil Rights Coordinator's determination. The Superintendent may conduct additional investigation of the facts and circumstances surrounding the complaint. The Superintendent shall affirm or reverse the Civil Rights Coordinator's decision and, if warranted, implement the Civil Rights Coordinator's proposed resolution or a modification thereof. The Superintendent's decision shall be final.

A person is not required to use the procedure outlined above and may instead file a complaint directly with the U.S. Department of Education Office for Civil Rights, 600 Superior Avenue East, Suite 750, OH 44114-2611.

Individuals who make complaints in good faith or are involved in the investigation of the complaint in accordance with this policy, shall be free from retaliation, threats, intimidation, coercion, discrimination and reprisal for reporting of the incident or participating in an investigation.

The District shall keep confidential the identity of the complainants, respondents, and witnesses, except as may be permitted by FERPA, or as required by law.

Retaliation is a separate violation distinct from the underlying complaint. Claims of retaliation, submitted in good faith and in writing to the Civil Rights Coordinator, shall be investigated pursuant to the procedures of this Board Policy. Individuals who engage in retaliation will be subject to corrective action or disciplinary action as indicated above, regardless of whether there has been a finding of cause for the

underlying complaint.

**BOARD POLICY
PERSONNEL**

**GAB
August 17, 2020**

NON-DISCRIMINATORY EMPLOYMENT PRACTICES

The Board of Education recognizes that discrimination is an institutional and societal problem which must be addressed by creating and maintaining an educational employment environment free of bias and prejudice. The school district shall continually review its educational programs and employment practices and decisions toward the goal of eliminating discrimination. The school district shall strive to create in the educational community an awareness of bias and prejudice and shall actively promote understanding and respect for all persons regardless of race, color, national origin, age, religion, sex, handicap, disability, height, weight, marital status, sexual orientation, sexual identity, or transgender status. Any employee who has notice of discrimination or harassment on the basis of sex of an employee or applicant shall immediately notify the Title IX Coordinator.

**BOARD POLICY
PERSONNEL**

**GAEA
August 17, 2020**

**DISCRIMINATORY HARASSMENT OF EMPLOYEES
OR APPLICANTS FOR EMPLOYMENT**

Discriminatory harassment of employees or applicants for employment by School District employees, Board members, vendors, contractors or others doing business with the School District, students, parents, invitees, guests, volunteers, etc., will not be tolerated. "Discriminatory harassment" means unwelcome sexual advances, requests for sexual favors or other verbal or physical conduct relating to an individual's sex, race, color, national origin, age, religion, height, weight, marital status, disability, sexual orientation, sexual identity, or transgender status when (a) submission to the conduct is made a condition of obtaining employment; (b) submission to, or rejection of, the conduct is used as a factor in decisions affecting the individual's employment; or (c) such conduct or communication has the purpose or effect of substantially interfering with the individual's employment, or creates an intimidating, hostile or offensive work environment.

Any employee or applicant who believes that he or she has suffered discriminatory harassment shall immediately report the incident(s) to the Director of Human Resources. In the event the employee or applicant cannot report to the Director of Human Resources, the employee shall report the incident(s) to the Superintendent. In the event that the employee or applicant is charging the Superintendent or a Board member with discriminatory harassment, he or she shall immediately report the incident(s) to the Board President. In the event that the employee or applicant is charging the Board President with such harassment, he or she shall report the incident to the Vice President of the Board. Any employee who has notice of discrimination or harassment on the basis of sex of an employee or applicant shall immediately notify the Title IX Coordinator. Any member of administration who becomes aware of discriminatory harassment of an employee or applicant on the basis of a protected class other than sex shall immediately notify the Director of Human Resources. Reports of discriminatory harassment may be made orally or in writing.

The School District guarantees that an employee or applicant reporting an incident(s) of discriminatory harassment will not suffer any form of reprisal.

In determining whether the alleged conduct constitutes discriminatory harassment, the totality of their circumstances, the nature of the conduct and the context in which the

alleged incident(s) occurred will be investigated. The School District has the responsibility of investigating and resolving complaints of discriminatory harassment. The School District shall first determine whether the complaint concerns allegations of (a) discrimination on the basis of sex in the educational programs and activities which it operates, including employment, admissions, recruitment, referrals, and collective bargaining, or (b) sexual harassment. If the allegations concern either of these matters, then the Director of Human Resources must notify the Title IX Coordinator and the complaint shall be resolved in accordance with the Title IX grievance procedures of Administrative Procedure JAA. If the Title IX grievance procedures are not applicable based upon the conduct alleged, then the allegations will be investigated in accordance with the procedures set forth Policy GAAA.

In cases where the alleged discriminatory harassment was committed by the Superintendent or a member of the Board of Education, the School District will appoint outside legal counsel to investigate the alleged incident(s). The results of an investigation and any action taken thereon will be communicated to the complaining person.

The School District considers discriminatory harassment to be a major offense which will result in corrective action, regardless of the offender's position with the School District. Corrective action of a School District employee may include disciplinary action, up to and including, termination of employment. Corrective action of a student may include disciplinary action, up to and including, expulsion.

**BOARD POLICY
STUDENTS
EQUAL EDUCATIONAL OPPORTUNITIES**

**JAA
August 17, 2020**

The school district prohibits unlawful discrimination on the basis of race, color, religion, sex, national origin, age, height, weight, marital status, handicap, disability, sexual orientation, sexual identity, or transgender status in any of its education programs or activities.

Students and other persons will not be denied participation in or the benefit of any educational program or activity, or discriminated against in any manner that violates state or federal law, on the basis of race, color, religion, sex, national origin, age, height, weight, marital status, handicap, disability or sexual orientation, sexual identity, or transgender status.

The Director of Student Services is appointed the Civil Rights Coordinator regarding complaints of disability/handicap discrimination involving educational services, programs, and activities. The Director of Human Resources is appointed the Civil Rights Coordinator regarding all other complaints of discrimination. These individuals are responsible for coordinating the implementation of the school district's obligations under state and federal laws that prohibit conduct also prohibited by this policy. A student or other person who believes that the school district or its board of education has not complied with the law or this policy may file a written complaint with the school district's civil rights coordinator within ten calendar days of the alleged violation. The coordinator shall first determine whether the complaint concerns allegations of (a) discrimination on the basis of sex in the educational programs and activities which it operates, including employment, admissions, recruitment, referrals, and collective bargaining, or (b) sexual harassment. If the allegations concern either of these matters, then the complaint shall be resolved in accordance with the Title IX complaint procedures set forth in Administrative Procedure JAA. If the Title IX complaint procedures are not applicable based upon the conduct alleged, then the School District has the responsibility of investigating and resolving complaints of

discriminatory harassment in accordance with the procedures set forth in this policy. The coordinator will meet with the person who filed the complaint and conduct a reasonable investigation into the facts and circumstances surrounding the complaint. If the coordinator determines that a violation has not occurred, the coordinator shall, in writing, so advise the person who filed the complaint and the school district's superintendent. If the coordinator determines that a violation has occurred, the coordinator shall put a determination in writing, propose a fair resolution of the complaint, and deliver the determination to the person who filed the complaint and the Superintendent.

The person who filed the complaint or the school district may appeal the coordinator's determination to the superintendent by so notifying the Superintendent within ten calendar days of the coordinator's determination. The Superintendent shall affirm or reverse the coordinator's determination and, if warranted, implement the coordinator's proposed resolution or a modification thereof. The Superintendent's decision shall be final.

**BOARD POLICY
STUDENTS
DISCRIMINATORY HARASSMENT
OF STUDENTS**

**JCED
August 17, 2020**

Discriminatory harassment of students by School District employees, Board members, vendors, contractors or others doing business with the School District, fellow students, parents, invitees, guests, volunteers, etc., will not be tolerated. "Discriminatory harassment" means unwelcome sexual advances, requests for sexual favors or other verbal or physical conduct relating to an individual's race, color, national origin, age, religion, height, weight, marital status, handicap, disability, sexual orientation, sexual identity, or transgender status when (a) submission to the conduct is made a condition of utilizing or benefiting from the services, activities or programs of the School District; (b) submission to, or rejection of, the conduct is used as the basis for a decision to exclude, expel or limit the student in terms, conditions, or privileges of the School District; or (c) the conduct has the purpose or effect of substantially interfering with the student's education, creates an intimidating, hostile or offensive educational environment. "Discriminatory harassment" on the basis of sex includes any of the following types of misconduct based upon sex: (a) an employee's conditioning the provision of an aid, benefit or service on an individual's participation in unwelcome sexual conduct (i.e., quid pro quo); (b) unwelcome conduct determined by a reasonable person to be so severe, pervasive, and objectively offensive that it effectively denies a person equal access to an education program or activity; or (3) sexual assault, dating violence, domestic violence, or stalking. Any student who believes that he or she has suffered discriminatory harassment shall report the incident(s) to his or her counselor or building principal. In the event that the student is charging the building principal with such discriminatory harassment, he or she shall report the incident(s) to the Superintendent. In the event that the student is charging the Superintendent or a Board member with such discriminatory harassment, he or she shall report the incident(s) to the Board President. In the event that the student is charging the Board President with such discriminatory harassment, he or she shall report the incident to the Vice President of the Board.

The School District guarantees that any student reporting incident(s) of discriminatory harassment will not suffer any form of reprisal.

Upon receipt of any student reporting that he or she suffered discriminatory harassment, the School District shall first determine whether the report concerns allegations of (a) discrimination on the basis of sex in the educational programs and

activities which it operates, including employment, admissions, recruitment, referrals, and collective bargaining, or (b) sexual harassment. If the allegations concern either of these matters, then the Title IX Coordinator must be immediately notified and the incident shall be resolved in accordance with the Title IX grievance procedures of Administrative Procedure JAA. If the Title IX grievance procedures are not applicable based upon the conduct alleged, then the incident will be investigated in accordance with the procedures set forth in this policy. In determining whether the alleged conduct constitutes discriminatory harassment, the totality of the circumstances, the nature of the conduct and the context in which the alleged incident(s) occurred will be investigated. The School District has the responsibility of investigating and resolving complaints of discriminatory harassment. In cases where the alleged discriminatory harassment was committed by the Superintendent or a member of the Board of Education, the School District will appoint outside legal counsel to investigate the alleged incident(s). The results of an investigation and any action taken thereon will be communicated to the complaining person.

The School District considers discriminatory harassment to be a major offense which will result in corrective action, regardless of the offender's position with the School District. Corrective action of a School District employee may include disciplinary action, up to and including, termination of employment. Corrective action of a student may include disciplinary action, up to and including, expulsion.

Ayes: Bonifield, Bradford, Burton, Centers, Frank, Jarvis, Johnson
Nays: None

Adjournment

President Johnson adjourned the meeting at 8:18 p.m.

Off/Supt/jw

**LIVONIA PUBLIC SCHOOLS
BOARD OF EDUCATION MEETING
September 28, 2020**

TOPIC: Approval of Extended COVID-19 Continuity of Learning Plan

RECOMMENDATION:

Move that the Board of Education of the Livonia Public Schools School District approve the *Extended COVID-19 Continuity of Learning Plan* for the remainder of the 2020-2021 school year. This plan includes a gradual return to in-person instruction, beginning on Monday, October 5, 2020.

RATIONALE:

This plan was developed to provide for a gradual return to in-person instruction for LPS students, while at the same time focusing on the safety of students and staff during the COVID-19 pandemic. The District's *Return to Learn Plan* is consistent with guidelines within the Michigan Safe Schools Roadmap and from the Wayne County Department of Health.

RESOURCE PERSONNEL:

Superintendent and LPS Administrative Team

EXHIBIT:

Presentation During Board Meeting on 9/21/2020

Off/Supt/jw

**LIVONIA PUBLIC SCHOOLS
BOARD OF EDUCATION MEETING
September 28, 2020**

TOPIC: Approval to Purchase i-Ready Instructional Licenses

RECOMMENDATION:

Move that the Board of Education of the Livonia Public Schools School District approve the purchase of the online adaptive instruction and assessment program, i-Ready Diagnostic Assessments for Math and Reading, from Curriculum Associates, for a total of \$302,221.00. This total includes free professional development, for a savings of \$55,635.00.

RATIONALE:

The purchase of i-Ready Diagnostic and Instruction will provide all kindergarten through sixth grade students with a State of Michigan approved assessment and instruction based on their personalized results. This will provide teachers with their students' strengths and weaknesses in reading and math. Additionally, students in grades seven, eight and nine will use the diagnostic portion of the program this year.

BUDGETARY INFORMATION:

The funding for this purchase will come from a mixture of Early Literacy Grant funds, 31A At-Risk state funds, and Academic Services Department funds.

RESOURCE PERSONNEL:

Theresa O'Brien, Chief Academic Officer

EXHIBITS:

Attachment

Curriculum Associates®

Prepared For:

Theresa O'Brien
Livonia Public School District
15125 Farmington Rd,
Livonia, MI 48154

8/14/2020

Dear Theresa O'Brien,

Thank you for requesting a price quote from Curriculum Associates. The chart below provides a summary of the products and/or services included. If you have any questions or would like any changes, please contact us.

Quote ID: 221721.4 Valid through: 12/31/2020

Product	List Price	Net Price
i-Ready	\$325,856.00	\$278,221.00
Professional Development	\$32,000.00	\$24,000.00
	List Total:	\$357,856.00
	Savings:	\$55,635.00
	Shipping/Tax/Other:	\$0.00
	Total:	\$302,221.00

Thank you again for your interest in Curriculum Associates.

Sincerely

Jeffrey Tompkins
313-316-0141
jtompkins@cainc.com

Please submit this quote with your purchase order

Curriculum Associates®

Quote ID: 221721.4 Date: 8/14/2020 Valid through: 12/31/2020

Prepared For:

Theresa O'Brien
Livonia Public School District
15125 Farmington Rd,
Livonia, MI 48154
tobrien@livoniapublicschools.org

Your Representative:

Jeffrey Tompkins
313-316-0141
jtompkins@cainc.com

Buchanan Elementary School 16400 Hubbard St, Livonia, MI 48154

Total Building Enrollment: 485

Product Name	Grade	Item #	Qty	List Price	Net Price	Total
i-Ready Assessment and Personalized Instruction Math and Reading Site License 351-500 Students 1 Year	Multiple	15003.0	1	\$17,490.00	\$16,615.50	\$16,615.50
i-Ready Implementation Support Services - Provisioning, Tech Support, Hosting, Data Management, Implementation Planning, Data Reviews, and Check ins (1 Year)	Multiple	27939.0	1	\$1,500.00	\$0.00	\$0.00
Subtotal:						\$16,615.50
Shipping:						\$0.00
Tax:						\$0.00
School Subtotal:						\$16,615.50

Churchill High School 8900 Newburgh Rd, Livonia, MI 48150

Total Building Enrollment: 1328

Product Name	Grade	Item #	Qty	List Price	Net Price	Total
i-Ready Assessment Math Per Student License Grades 9-12 1 Year	Multiple	14928.0	332	\$6.00	\$2.00	\$664.00
i-Ready Math Instruction Add On Per Student License 1 Year	Multiple	13178.0	25	\$24.00	\$21.60	\$540.00
i-Ready Assessment Reading Per Student License Grades 9-12 1 Year	Multiple	14936.0	332	\$6.00	\$2.00	\$664.00
i-Ready Reading Instruction Add On Per Student License 1 Year	Multiple	13171.0	25	\$24.00	\$21.60	\$540.00
Subtotal:						\$2,408.00
Shipping:						\$0.00
Tax:						\$0.00
School Subtotal:						\$2,408.00

Cleveland Elementary School 28030 Cathedral St, Livonia, MI 48150

Total Building Enrollment: 489

Product Name	Grade	Item #	Qty	List Price	Net Price	Total
i-Ready Assessment and Personalized Instruction Math and Reading Site License 351-500 Students 1 Year	Multiple	15003.0	1	\$17,490.00	\$16,615.50	\$16,615.50
i-Ready Implementation Support Services - Provisioning, Tech Support, Hosting, Data Management, Implementation Planning, Data Reviews, and Check ins (1 Year)	Multiple	27939.0	1	\$1,500.00	\$0.00	\$0.00
Subtotal:						\$16,615.50
Shipping:						\$0.00
Tax:						\$0.00

School Subtotal: \$16,615.50

Coolidge Elementary School 30500 Curtis Rd, Livonia, MI 48152

Total Building Enrollment: 495

Product Name	Grade	Item #	Qty	List Price	Net Price	Total
i-Ready Assessment and Personalized Instruction Math and Reading Site License 351-500 Students 1 Year	Multiple	15003.0	1	\$17,490.00	\$16,615.50	\$16,615.50
i-Ready Implementation Support Services - Provisioning, Tech Support, Hosting, Data Management, Implementation Planning, Data Reviews, and Check ins (1 Year)	Multiple	27939.0	1	\$1,500.00	\$0.00	\$0.00
Subtotal:						\$16,615.50
Shipping:						\$0.00
Tax:						\$0.00
School Subtotal:						\$16,615.50

Cooper Upper Elementary School 28550 Ann Arbor Trl, Westland, MI 48185

Total Building Enrollment: 649

Product Name	Grade	Item #	Qty	List Price	Net Price	Total
i-Ready Assessment and Personalized Instruction Math and Reading Site License 501-800 Students 1 Year	Multiple	15004.0	1	\$20,600.00	\$19,570.00	\$19,570.00
i-Ready Implementation Support Services - Provisioning, Tech Support, Hosting, Data Management, Implementation Planning, Data Reviews, and Check ins (1 Year)	Multiple	27939.0	1	\$1,500.00	\$0.00	\$0.00
Subtotal:						\$19,570.00
Shipping:						\$0.00
Tax:						\$0.00
School Subtotal:						\$19,570.00

Emerson Middle School 29100 W Chicago St, Livonia, MI 48150

Total Building Enrollment: 732

Product Name	Grade	Item #	Qty	List Price	Net Price	Total
i-Ready Assessment Math Per Student License 1 Year	Multiple	13086.0	732	\$6.00	\$5.40	\$3,952.80
i-Ready Math Instruction Add On Per Student License 1 Year	Multiple	13178.0	25	\$24.00	\$21.60	\$540.00
i-Ready Assessment Reading Per Student License 1 Year	Multiple	13088.0	732	\$6.00	\$5.40	\$3,952.80
i-Ready Reading Instruction Add On Per Student License 1 Year	Multiple	13171.0	25	\$24.00	\$21.60	\$540.00
Subtotal:						\$8,985.60
Shipping:						\$0.00
Tax:						\$0.00
School Subtotal:						\$8,985.60

Franklin High School 31000 Joy Rd, Livonia, MI 48150

Total Building Enrollment: 1430

Product Name	Grade	Item #	Qty	List Price	Net Price	Total
i-Ready Assessment Math Per Student License Grades 9-12 1 Year	Multiple	14928.0	358	\$6.00	\$2.00	\$716.00
i-Ready Math Instruction Add On Per Student License 1 Year	Multiple	13178.0	25	\$24.00	\$21.60	\$540.00
i-Ready Assessment Reading Per Student License Grades 9-12 1 Year	Multiple	14936.0	358	\$6.00	\$2.00	\$716.00
i-Ready Reading Instruction Add On Per Student License 1 Year	Multiple	13171.0	25	\$24.00	\$21.60	\$540.00
Subtotal:						\$2,512.00

Shipping:	\$0.00
Tax:	\$0.00
School Subtotal:	\$2,512.00

Frost Middle School 14041 Stark Rd, Livonia, MI 48154

Total Building Enrollment: 631

Product Name	Grade	Item #	Qty	List Price	Net Price	Total
i-Ready Assessment Math Per Student License 1 Year	Multiple	13086.0	631	\$6.00	\$5.40	\$3,407.40
i-Ready Math Instruction Add On Per Student License 1 Year	Multiple	13178.0	25	\$24.00	\$21.60	\$540.00
i-Ready Assessment Reading Per Student License 1 Year	Multiple	13088.0	631	\$6.00	\$5.40	\$3,407.40
i-Ready Reading Instruction Add On Per Student License 1 Year	Multiple	13171.0	25	\$24.00	\$21.60	\$540.00
Subtotal:						\$7,894.80
Shipping:						\$0.00
Tax:						\$0.00
School Subtotal:						\$7,894.80

Grant Elementary School 9300 Hubbard St, Livonia, MI 48150

Total Building Enrollment: 532

Product Name	Grade	Item #	Qty	List Price	Net Price	Total
i-Ready Assessment and Personalized Instruction Math and Reading Site License 501-800 Students 1 Year	Multiple	15004.0	1	\$20,600.00	\$19,570.00	\$19,570.00
i-Ready Implementation Support Services - Provisioning, Tech Support, Hosting, Data Management, Implementation Planning, Data Reviews, and Check ins (1 Year)	Multiple	27939.0	1	\$1,500.00	\$0.00	\$0.00
Subtotal:						\$19,570.00
Shipping:						\$0.00
Tax:						\$0.00
School Subtotal:						\$19,570.00

Hayes Elementary School 30600 Louise St, Westland, MI 48185

Total Building Enrollment: 512

Product Name	Grade	Item #	Qty	List Price	Net Price	Total
i-Ready Assessment and Personalized Instruction Math and Reading Site License 501-800 Students 1 Year	Multiple	15004.0	1	\$20,600.00	\$19,570.00	\$19,570.00
i-Ready Implementation Support Services - Provisioning, Tech Support, Hosting, Data Management, Implementation Planning, Data Reviews, and Check ins (1 Year)	Multiple	27939.0	1	\$1,500.00	\$0.00	\$0.00
Subtotal:						\$19,570.00
Shipping:						\$0.00
Tax:						\$0.00
School Subtotal:						\$19,570.00

Holmes Middle School 16200 Newburgh Rd, Livonia, MI 48154

Total Building Enrollment: 737

Product Name	Grade	Item #	Qty	List Price	Net Price	Total
i-Ready Assessment Math Per Student License 1 Year	Multiple	13086.0	737	\$6.00	\$5.40	\$3,979.80
i-Ready Math Instruction Add On Per Student License 1 Year	Multiple	13178.0	25	\$24.00	\$21.60	\$540.00
i-Ready Assessment Reading Per Student License 1 Year	Multiple	13088.0	737	\$6.00	\$5.40	\$3,979.80

i-Ready Reading Instruction Add On Per Student License 1 Year	Multiple	13171.0	25	\$24.00	\$21.60	\$540.00
					Subtotal:	\$9,039.60
					Shipping:	\$0.00
					Tax:	\$0.00
					School Subtotal:	\$9,039.60

Hoover Elementary School 15900 Levan Rd, Livonia, MI 48154

Total Building Enrollment: 500

Product Name	Grade	Item #	Qty	List Price	Net Price	Total
i-Ready Assessment and Personalized Instruction Math and Reading Site License 351-500 Students 1 Year	Multiple	15003.0	1	\$17,490.00	\$16,615.50	\$16,615.50
i-Ready Implementation Support Services - Provisioning, Tech Support, Hosting, Data Management, Implementation Planning, Data Reviews, and Check ins (1 Year)	Multiple	27939.0	1	\$1,500.00	\$0.00	\$0.00
					Subtotal:	\$16,615.50
					Shipping:	\$0.00
					Tax:	\$0.00
					School Subtotal:	\$16,615.50

Johnson Upper Elementary Sch 8400 N Hix Rd, Westland, MI 48185

Total Building Enrollment: 506

Product Name	Grade	Item #	Qty	List Price	Net Price	Total
i-Ready Assessment and Personalized Instruction Math and Reading Site License 501-800 Students 1 Year	Multiple	15004.0	1	\$20,600.00	\$19,570.00	\$19,570.00
i-Ready Implementation Support Services - Provisioning, Tech Support, Hosting, Data Management, Implementation Planning, Data Reviews, and Check ins (1 Year)	Multiple	27939.0	1	\$1,500.00	\$0.00	\$0.00
					Subtotal:	\$19,570.00
					Shipping:	\$0.00
					Tax:	\$0.00
					School Subtotal:	\$19,570.00

Kennedy Elementary School 14201 Hubbard St, Livonia, MI 48154

Total Building Enrollment: 437

Product Name	Grade	Item #	Qty	List Price	Net Price	Total
i-Ready Assessment and Personalized Instruction Math and Reading Site License 351-500 Students 1 Year	Multiple	15003.0	1	\$17,490.00	\$16,615.50	\$16,615.50
i-Ready Implementation Support Services - Provisioning, Tech Support, Hosting, Data Management, Implementation Planning, Data Reviews, and Check ins (1 Year)	Multiple	27939.0	1	\$1,500.00	\$0.00	\$0.00
					Subtotal:	\$16,615.50
					Shipping:	\$0.00
					Tax:	\$0.00
					School Subtotal:	\$16,615.50

Livonia Public School District 15125 Farmington Rd, Livonia, MI 48154

Total Building Enrollment: 8905

Product Name	Grade	Item #	Qty	List Price	Net Price	Total
--------------	-------	--------	-----	------------	-----------	-------

i-Ready Assessment and Personalized Instruction Prof Dev On Site Add on Leadership Session (Up to 3 hrs)	Multiple	19984.0	1	\$0.00	\$0.00	\$0.00
i-Ready Assessment and Personalized Instruction Prof Dev On Site Practicing User Helping all Learners Succeed Session (up to 6 hrs)	Multiple	16927.0	2	\$2,000.00	\$1,500.00	\$3,000.00
i-Ready Assessment and Personalized Instruction Prof Dev On Site New User Getting Good Data Session (up to 6 hrs)	Multiple	14432.0	7	\$2,000.00	\$1,500.00	\$10,500.00
i-Ready Assessment and Personalized Instruction Prof Dev On Site Practicing User Delivering Differentiated Instruction Session (up to 6 hrs)	Multiple	16965.0	7	\$2,000.00	\$1,500.00	\$10,500.00
					Subtotal:	\$24,000.00
					Shipping:	\$0.00
					Tax:	\$0.00
					School Subtotal:	\$24,000.00

Niji-Iro Japanese Immersion Es 36611 Curtis Rd, Livonia, MI 48152

Total Building Enrollment: 54

Product Name	Grade	Item #	Qty	List Price	Net Price	Total
i-Ready Assessment and Personalized Instruction Math and Reading Site License 200 or fewer Students 1 Year	Multiple	15001.0	1	\$7,350.00	\$6,982.50	\$6,982.50
i-Ready Implementation Support Services - Provisioning, Tech Support, Hosting, Data Management, Implementation Planning, Data Reviews, and Check ins (1 Year)	Multiple	27939.0	1	\$1,500.00	\$0.00	\$0.00
					Subtotal:	\$6,982.50
					Shipping:	\$0.00
					Tax:	\$0.00
					School Subtotal:	\$6,982.50

Randolph Elementary School 14470 Norman St, Livonia, MI 48154

Total Building Enrollment: 484

Product Name	Grade	Item #	Qty	List Price	Net Price	Total
i-Ready Assessment and Personalized Instruction Math and Reading Site License 351-500 Students 1 Year	Multiple	15003.0	1	\$17,490.00	\$16,615.50	\$16,615.50
i-Ready Implementation Support Services - Provisioning, Tech Support, Hosting, Data Management, Implementation Planning, Data Reviews, and Check ins (1 Year)	Multiple	27939.0	1	\$1,500.00	\$0.00	\$0.00
					Subtotal:	\$16,615.50
					Shipping:	\$0.00
					Tax:	\$0.00
					School Subtotal:	\$16,615.50

Riley Upper Elementary School 15555 Henry Ruff St, Livonia, MI 48154

Total Building Enrollment: 704

Product Name	Grade	Item #	Qty	List Price	Net Price	Total
i-Ready Assessment and Personalized Instruction Math and Reading Site License 501-800 Students 1 Year	Multiple	15004.0	1	\$20,600.00	\$19,570.00	\$19,570.00
i-Ready Implementation Support Services - Provisioning, Tech Support, Hosting, Data Management, Implementation Planning, Data Reviews, and Check ins (1 Year)	Multiple	27939.0	1	\$1,500.00	\$0.00	\$0.00
					Subtotal:	\$19,570.00
					Shipping:	\$0.00

Tax:	\$0.00
School Subtotal:	\$19,570.00

Roosevelt Elementary School 30200 Lyndon St, Livonia, MI 48154

Total Building Enrollment: 359

Product Name	Grade	Item #	Qty	List Price	Net Price	Total
i-Ready Assessment and Personalized Instruction Math and Reading Site License 351-500 Students 1 Year	Multiple	15003.0	1	\$17,490.00	\$16,615.50	\$16,615.50
i-Ready Implementation Support Services - Provisioning, Tech Support, Hosting, Data Management, Implementation Planning, Data Reviews, and Check ins (1 Year)	Multiple	27939.0	1	\$1,500.00	\$0.00	\$0.00
Subtotal:						\$16,615.50
Shipping:						\$0.00
Tax:						\$0.00
School Subtotal:						\$16,615.50

Rosedale Elementary School 36651 Ann Arbor Trl, Livonia, MI 48150

Total Building Enrollment: 281

Product Name	Grade	Item #	Qty	List Price	Net Price	Total
i-Ready Assessment and Personalized Instruction Math and Reading Site License 201-350 Students 1 Year	Multiple	15002.0	1	\$12,320.00	\$11,704.00	\$11,704.00
i-Ready Implementation Support Services - Provisioning, Tech Support, Hosting, Data Management, Implementation Planning, Data Reviews, and Check ins (1 Year)	Multiple	27939.0	1	\$1,500.00	\$0.00	\$0.00
Subtotal:						\$11,704.00
Shipping:						\$0.00
Tax:						\$0.00
School Subtotal:						\$11,704.00

Stevenson High School 33500 6 Mile Rd, Livonia, MI 48152

Total Building Enrollment: 1752

Product Name	Grade	Item #	Qty	List Price	Net Price	Total
i-Ready Assessment Math Per Student License Grades 9-12 1 Year	Multiple	14928.0	438	\$6.00	\$2.00	\$876.00
i-Ready Math Instruction Add On Per Student License 1 Year	Multiple	13178.0	25	\$24.00	\$21.60	\$540.00
i-Ready Assessment Reading Per Student License Grades 9-12 1 Year	Multiple	14936.0	438	\$6.00	\$2.00	\$876.00
i-Ready Reading Instruction Add On Per Student License 1 Year	Multiple	13171.0	25	\$24.00	\$21.60	\$540.00
Subtotal:						\$2,832.00
Shipping:						\$0.00
Tax:						\$0.00
School Subtotal:						\$2,832.00

Webster Elementary School 32401 Pembroke St, Livonia, MI 48152

Total Building Enrollment: 315

Product Name	Grade	Item #	Qty	List Price	Net Price	Total
i-Ready Assessment and Personalized Instruction Math and Reading Site License 201-350 Students 1 Year	Multiple	15002.0	1	\$12,320.00	\$11,704.00	\$11,704.00

i-Ready Implementation Support Services - Provisioning, Tech Support, Hosting, Data Management, Implementation Planning, Data Reviews, and Check ins (1 Year)	Multiple	27939.0	1	\$1,500.00	\$0.00	\$0.00
					Subtotal:	\$11,704.00
					Shipping:	\$0.00
					Tax:	\$0.00
					School Subtotal:	\$11,704.00

Total	
List Total:	\$357,856.00
Savings:	\$55,635.00
Merchandise Total:	\$302,221.00
Voucher/Credit:	\$0.00
Estimated Tax:	\$0.00
Estimated Shipping:	\$0.00
Total:	\$302,221.00

Special Notes
All i-Ready purchases require professional development. 10% discount applied to i-Ready per student licenses and 5% discount applied to i-Ready site licenses based on scope of quote.

F.O.B.: N. Billerica, MA 01862
Shipping: Shipping based on MDSE total
Terms: Net 30 days, pending credit approval
Fed. ID: #26-3954988

Please submit this quote with your purchase order

Y22

**LIVONIA PUBLIC SCHOOLS
BOARD OF EDUCATION MEETING
September 28, 2020**

TOPIC: **Approval to Purchase Program Supplies**

RECOMMENDATION:

Move that the Board of Education of the Livonia Public Schools School District approve the purchase of supplies for a multisensory approach to reading instruction from the Institute for Multi-Sensory Education, for a total amount of \$95,167.50.

RATIONALE:

Student Services is requesting additional supplies to enhance reading instruction.

BUDGETARY INFORMATION:

These purchases will be paid for with a State Grant.

RESOURCE PERSONNEL:

Jennifer Taiariol, Director of Student Services

EXHIBITS:

Attached



Powerful. Reading. Instruction.

24800 Denso Drive, Suite 202
 Southfield, MI 48033
 Phone: 800-646-9788 Fax: 248-735-2927

Price Quote

DATE 9/16/2020
 Quotation # 2020-103

Quote For:
 Livonia Public Schools
 15125 Farmington Rd.
 Livonia, MI 48154

QUANTITY	DESCRIPTION	UNIT PRICE	AMOUNT
35	K teachers, Level 1 Teacher Practice & Assessment (\$4.95 each)	\$ 4.95	\$173.25
33	Gr 1 teachers, Level 1 Teacher Practice & Assessment (\$4.95 each)	\$ 4.95	\$163.35
32	Gr 2 teachers, Level 2 Teacher Practice & Assessment (\$4.95 each)	\$ 4.95	\$158.40
13	K Template Bundle - \$45/bundle	\$ -	\$0.00
13	Gr 1 Template Bundle - \$45/bundle	\$ -	\$0.00
13	Gr 2 Template Bundle - \$45/bundle	\$ -	\$0.00
1,050	Level 1 Spelling Practice & Assessment Initial (\$6.50 each)	\$ 6.50	\$6,825.00
990	Level 1 Spelling Practice & Assessment Initial (\$6.50 each)	\$ 6.50	\$6,435.00
990	Level 1 Spelling Practice & Assessment Mid/Final (5.50 each)	\$ 5.50	\$5,445.00
960	Level 2 Student Spelling Book I,M &F (\$7.50 each)	\$ 7.50	\$7,200.00
2,650	OG in a Bag (\$25.95 each x 2650 students)	\$ 25.95	\$68,767.50

TOTAL **\$ 95,167.50**

Please email the signed copy of your approved purchase order to accounting@imse.com

Your Quote is good for 90 days after the Quote Date shown above.

THANK YOU FOR YOUR BUSINESS!

**LIVONIA PUBLIC SCHOOLS
BOARD OF EDUCATION MEETING
September 28, 2020**

TOPIC: **Approval of Resolution for Bond Refinancing**

RECOMMENDATION:

Move that the Board of Education of the Livonia Public Schools School District approve the attached resolution to ratify the refunding of the 2013 Bonds, Series I and 2014 Refunding Bonds.

RATIONALE:

Approval will ratify the refunding of the 2013 Building and Site Bonds, Series I, dated June 27, 2013 and the 2014 Refunding Bonds, dated February 13, 2014, and ratifies and affirms Superintendent Andrea Oquist's acceptance of the offer from JP Morgan Securities LLC, Chicago, Illinois (the underwriter) for the purchase of the refunding bond issue.

BUDGETARY INFORMATION:

None.

RESOURCE PERSONNEL:

Alison Smith, Director of Finance

EXHIBITS:

Attached.

kp

Livonia Public Schools School District, Wayne County, Michigan (the “Issuer”)

A regular meeting of the board of education of the Issuer (the “Board”) was held:

in the Administration Office, 15125 Farmington Road, Livonia, Michigan, 48154, within the boundaries of the Issuer,

electronically pursuant to Executive Order through _____ with identification number _____ on the 28th day of September, 2020, at 7 o’clock in the p.m. (the “Meeting”)

The Meeting was called to order by Mark Johnson, President.

Present: Members

Absent: Members

The following preamble and resolution were offered by Member _____ and supported by Member _____:

WHEREAS:

1. By resolution adopted on August 17, 2020 (the “Bond Resolution”), this Board authorized the issuance of not to exceed One Hundred Four Million Dollars (\$104,000,000) 2020 Refunding Bonds (General Obligation - Unlimited Tax) (Federally Taxable) (the “Bonds”) for the purpose of refunding that portion of the Issuer’s 2013 School Building and Site Bonds, Series I which are callable on or after May 1, 2023, and are due and payable May 1, 2025 through May 1, 2043, inclusive, and the Issuer’s 2014 Refunding Bonds which are callable on or after May 1, 2023, and are due and payable May 1, 2025 (collectively, the “Refunded Bonds”); and

2. In the Bond Resolution, the Issuer authorized the Superintendent of Schools and/or the Director of Finance (each an “Authorized Officer”) to accept the offer of an underwriter to purchase the Bonds within the parameters set forth in such resolution; and

3. Based upon information provided by the Issuer’s financial consulting firm and J.P. Morgan Securities LLC (the “Underwriter”), the Issuer selected a negotiated sale to allow for flexibility in the timing, sale and structure of the Bonds in response to changing market conditions and to allow for flexibility in sizing the defeasance escrow necessary to accomplish the refunding of the Refunded Bonds; and

4. The Underwriter presented an offer to purchase the Bonds to an Authorized Officer on September 24, 2020, which an Authorized Officer accepted pursuant to the authority delegated in the Bond Resolution.

NOW, THEREFORE, BE IT RESOLVED THAT:

1. The Authorized Officer’s acceptance of the Underwriter’s offer as set forth in the bond purchase agreement (the “Bond Purchase Agreement”), and the terms and conditions set forth therein, presented to the Authorized Officer on September 24, 2020, to purchase the Bonds in the principal amount of \$90,770,000 at a purchase price of \$90,637,320.16, which is the par value of

the Bonds, less the Underwriter's discount of \$132,679.84, is hereby ratified and affirmed. The Bonds shall be issued in the aggregate principal sum of \$90,770,000 and designated 2020 Refunding Bonds (General Obligation - Unlimited Tax) (Federally Taxable). The Underwriter has agreed in the Bond Purchase Agreement that it shall initially offer the Bonds to the public at the yields set forth in Exhibit A hereto.

2. The Bonds shall be dated October 21, 2020, and shall mature on May 1 of the years 2021 and 2023 through 2043, inclusive, on which interest is payable commencing May 1, 2021 and semi-annually thereafter on November 1 and May 1 at the rates and in the principal amounts set forth in Exhibit A and shall be subject to optional redemption as set forth herein. The Bonds shall be initially offered to the public at the initial offering yields as set forth in Exhibit A hereto.

3. The Bonds or portions of Bonds in multiples of \$5,000, maturing on or after May 1, 2031, shall be subject to redemption prior to maturity, at the option of the Issuer in such order as the Issuer may determine and by lot within any maturity, on any date occurring on or after May 1, 2030, at par plus accrued interest to the redemption date.

4. Notice of redemption of any Bond shall be given not less than thirty (30) days and not more than sixty (60) days prior to the date fixed for redemption by mail to the registered owner's or owners' registered address shown on the registration books kept by the Paying Agent (the "Paying Agent"). The Bonds shall be called for redemption in multiples of \$5,000, and Bonds of denominations of more than \$5,000 shall be treated as representing the number of Bonds obtained by dividing the denomination of the Bond by \$5,000, and such Bonds may be redeemed in part. The notice of redemption for Bonds redeemed in part shall state that upon surrender of the Bond to be redeemed a new Bond or Bonds in an aggregate principal amount equal to the unredeemed portion of the Bond surrendered shall be issued to the registered owner thereof.

If less than all of the Bonds of any maturity shall be called for redemption prior to maturity, unless otherwise provided, the particular Bonds or portions of Bonds to be redeemed shall be selected by the Paying Agent, in such manner as the Paying Agent in its discretion may deem proper, in the principal amounts designated by the Issuer. Any Bonds selected for redemption which are deemed to be paid in accordance with the provisions of the Bond Resolution and this resolution will cease to bear interest on the date fixed for redemption. Upon presentation and surrender of such Bonds at the corporate trust office of the Paying Agent, such Bonds shall be paid and redeemed.

5. Blank Bonds with the manual or facsimile signatures of the President and Secretary of the Board affixed thereto, shall, upon issuance and delivery and from time to time thereafter as necessary, be delivered to the Paying Agent for safekeeping to be used for registration and transfer of ownership.

The Bonds are registered as to principal and interest and are transferable as provided in the Bond Resolution only upon the books of the Issuer kept for that purpose by the Paying Agent, by the registered owner thereof in person or by an agent of the owner duly authorized in writing, upon the surrender of the Bond together with a written instrument of transfer satisfactory to the Paying Agent duly executed by the registered owner or agent thereof and thereupon a new Bond or Bonds in the same aggregate principal amount and of the same maturity shall be issued to the transferee in exchange therefor as provided in the Bond Resolution, and upon payment of the charges, if any,

therein provided. The Bonds are issuable in denominations of \$5,000, or any integral multiple thereof, not exceeding the aggregate principal amount for each maturity.

If any Bond shall become mutilated, the Issuer, at the expense of the holder of the Bonds, shall furnish or cause to be furnished, and the Paying Agent shall authenticate and deliver, a new Bond of like tenor in exchange and substitution of the mutilated Bond, upon surrender to the Paying Agent of the mutilated Bond. If any Bond issued under this resolution shall be lost, destroyed or stolen, evidence of the loss, destruction or theft and indemnity may be submitted to the Paying Agent, and if satisfactory to the Paying Agent and the Issuer, the Issuer at the expense of the owner, shall furnish or cause to be furnished, and the Paying Agent shall authenticate and deliver a new Bond of like tenor and bearing the statement required by Act 354, Public Acts of Michigan, 1972, as amended, being sections 129.131 to 129.134, inclusive, of the Michigan Compiled Laws, or any applicable law hereafter enacted, in lieu of and in substitution of the Bond so lost, destroyed or stolen. If any such Bond shall have matured or shall be about to mature, instead of issuing a substitute Bond, the Paying Agent may pay the same without surrender thereof.

6. The Huntington National Bank, Grand Rapids, Michigan, is hereby approved as Escrow Agent under the proposed Escrow Agreement (the "Escrow Agreement") presented to the Board. The Escrow Agreement providing for payment and redemption of the Refunded Bonds is hereby approved. The President or Secretary shall execute and deliver the Escrow Agreement substantially in the form presented to the Board with such changes and completions as shall be necessary as determined by Thrun Law Firm, P.C., in order to accomplish refunding the Refunded Bonds in accordance with the law and the Bond Resolution. The Escrow Agent is further authorized to act as the Issuer's Agent, an attorney-in-fact for the purpose of acquiring on behalf of the Issuer the federal securities, if necessary, as defined in the Escrow Agreement to meet the Board's obligations under the Escrow Agreement.

7. Upon delivery of the Bonds, the accrued interest, if any, shall be deposited in the Debt Retirement Fund for the Bonds and the balance of the Bond proceeds shall be used as follows:

A. The approximate sum of \$264,707.50 shall be used to pay the cost of issuance of the Bonds, and any balance remaining from that sum shall be deposited in the Debt Retirement Fund for the Bonds.

B. The sum of \$90,192,230.31 from the Bonds, together with funds on hand from the 2013 Debt Retirement Fund Account in the amount of \$1,879,390.00 and the 2014 Debt Retirement Fund Account in the amount of \$3,232,011.00, shall be paid to the Escrow Agent and then invested by it as provided in the Bond Resolution and Exhibit C of the Escrow Agreement for payment of principal and interest on the Refunded Bonds. Any funds from the Bond proceeds not used for the Escrow Account shall be deposited in the Debt Retirement Fund for the Bonds.

C. The sum of \$176,414.80 from the Bonds shall be used to purchase municipal bond insurance for the Bonds from Build America Mutual Assurance Company, New York, New York (the "Insurer").

8. The President and Secretary are hereby authorized to provide the Bonds in conformity with the specifications of this resolution by causing their manual or facsimile signatures to be affixed thereto, and upon the manual execution by the authorized signatory of the

Paying Agent, the Treasurer be and is hereby authorized and directed to cause said Bonds to be delivered to the Underwriter upon receipt of the purchase price and accrued interest, if any.

9. The Preliminary Official Statement, dated September 17, 2020, is deemed final for purposes of SEC Rule 15c2-12(b)(1), relating to the Bonds and its use and distribution by the Underwriter is hereby authorized, approved and confirmed.

10. An Authorized Officer is authorized and directed to execute and deliver the final Official Statement on behalf of the Issuer. An Authorized Officer is further authorized to approve, execute and deliver any amendments and supplements to the final Official Statement necessary to assure that the statements therein are true, as of the time the Bonds are delivered to the Underwriter, and that it does not contain any untrue statement of a material fact and does not omit to state a material fact necessary in order to make the statements, in light of the circumstances under which they were made, not misleading. In the absence of an Authorized Officer, the President may execute the above documents.

11. The President or Vice President, the Secretary, the Treasurer, the Superintendent, the Director of Finance, and/or all other officers, agents and representatives of the Issuer and each of them shall execute, issue and deliver any certificates, statements, warranties, representations, or documents necessary to effect the purposes of this resolution, the Bonds or the Bond Purchase Agreement.

12. The officers, agents and employees of the Issuer are authorized to take all other actions necessary and convenient to facilitate sale and delivery of the Bonds.

13. The Issuer hereby authorizes the purchase of municipal bond insurance from the Insurer. The cost of the insurance is hereby approved in the amount of \$176,414.80. The Insurance Commitment for the municipal bond insurance for the Bonds rendered by the Insurer, attached hereto as Exhibit C, is hereby accepted, and the President, the Vice President, or an Authorized Officer is hereby authorized to execute acceptance of the Insurance Commitment and the administration is authorized to provide the documents required by the Insurance Commitment.

14. The Issuer hereby appoints The Huntington National Bank, Grand Rapids, Michigan, as Paying Agent-Bond Registrar and directs an Authorized Officer to execute for and on behalf of the Issuer a Paying Agent-Bond Registrar Agreement.

15. The debt levy heretofore certified for the 2020 tax year is hereby reallocated for the July and/or December 2020 levy as shown on the attached Exhibit B.

16. All resolutions and parts of resolutions insofar as they conflict with the provisions of this resolution be and the same are hereby rescinded.

Ayes: Members

Nays: Members

Resolution declared adopted.

Secretary, Board of Education

The undersigned duly qualified and acting Secretary of the Board of Education of Livonia Public Schools School District, Wayne County, Michigan, hereby certifies that the foregoing constitutes a true and complete copy of a resolution adopted by the Board at the Meeting, the original of which is part of the Board's minutes. The undersigned further certifies that notice of the meeting was given to the public pursuant to the provisions of the "Open Meetings Act" (Act 267, Public Acts of Michigan, 1976, as amended).

Secretary, Board of Education

MFH/klg



EXHIBIT A



555 Bnwood Circle
Suite 333
Ann Arbor, MI 48108
734-994-9700
734-994-9710 fax
www.pfm.com

\$90,770,000
LIVONIA PUBLIC SCHOOLS SCHOOL DISTRICT
COUNTY OF WAYNE, STATE OF MICHIGAN
2020 REFUNDING BONDS
(GENERAL OBLIGATION - UNLIMITED TAX)
(FEDERALLY TAXABLE)
BOND PRODUCTION REPORT

Sale Date: 9/23/2020 First Coupon Date: 5/1/2021
Dated Date: 10/21/2020 First Call Date: 5/1/2030
Delivery Date: 10/21/2020 First Call Premium: 100%

Principal Due	Principal	Bond Type	Cumulative Bond Years	Coupon	Yield	Price	Yield to Maturity	Price to Maturity	Gross Production
5/1/2021	\$1,000,000	Serial	528	0.311%	0.311%	100.000	0.311%	100.000	\$1,000,000.00
5/1/2022	0	Serial	528			100.000		100.000	0.00
5/1/2023	1,245,000	Serial	3,675	0.528%	0.528%	100.000	0.528%	100.000	1,245,000.00
5/1/2024	1,255,000	Serial	8,102	0.741%	0.741%	100.000	0.741%	100.000	1,255,000.00
5/1/2025	6,920,000	Serial	39,434	0.871%	0.871%	100.000	0.871%	100.000	6,920,000.00
5/1/2026	4,285,000	Serial	63,121	1.163%	1.163%	100.000	1.163%	100.000	4,285,000.00
5/1/2027	4,300,000	Serial	91,190	1.313%	1.313%	100.000	1.313%	100.000	4,300,000.00
5/1/2028	4,315,000	Serial	123,673	1.519%	1.519%	100.000	1.519%	100.000	4,315,000.00
5/1/2029	4,335,000	Serial	160,641	1.629%	1.629%	100.000	1.629%	100.000	4,335,000.00
5/1/2030	4,355,000	Serial	202,134	1.719%	1.719%	100.000	1.719%	100.000	4,355,000.00
5/1/2031	4,370,000	Serial	248,141	1.879%	1.879%	100.000	1.879%	100.000	4,370,000.00
5/1/2032	4,385,000	Serial	298,690	2.019%	2.019%	100.000	2.019%	100.000	4,385,000.00
5/1/2033	4,405,000	Serial	353,875	2.109%	2.109%	100.000	2.109%	100.000	4,405,000.00
5/1/2034	4,420,000	Serial	413,668	2.209%	2.209%	100.000	2.209%	100.000	4,420,000.00
5/1/2035	4,435,000	Serial	478,098	2.309%	2.309%	100.000	2.309%	100.000	4,435,000.00
5/1/2036	4,470,000	Serial	547,507	2.516%	2.516%	100.000	2.516%	100.000	4,470,000.00
5/1/2037	4,510,000	Serial	622,048	2.616%	2.616%	100.000	2.616%	100.000	4,510,000.00
5/1/2038	4,545,000	Serial	701,711	2.716%	2.716%	100.000	2.716%	100.000	4,545,000.00
5/1/2039	4,580,000	Serial	786,569	2.816%	2.816%	100.000	2.816%	100.000	4,580,000.00
5/1/2040	4,615,000	Serial	876,689	2.866%	2.866%	100.000	2.866%	100.000	4,615,000.00
5/1/2041	4,645,000	Serial	972,041	2.916%	2.916%	100.000	2.916%	100.000	4,645,000.00
5/1/2042	4,670,000	Serial	1,072,576	2.966%	2.966%	100.000	2.966%	100.000	4,670,000.00
5/1/2043	4,710,000	Serial	1,178,681	3.016%	3.016%	100.000	3.016%	100.000	4,710,000.00
5/1/2044	0	Serial	1,178,681			100.000		100.000	0.00
	<u>\$90,770,000</u>								<u>\$90,770,000.00</u>

Par Amount:	\$90,770,000.00
Production (Discount)/Premium:	0.00
Gross Production:	90,770,000.00 100.00000%
Bond Insurance:	(176,414.80) -0.19435%
Underwriter's Discount:	(132,679.84) -0.14617%
Bid:	<u>90,460,905.36 99.65947%</u>
Accrued:	0.00
Net to Issuer:	<u>\$90,460,905.36</u>

Gross Interest Cost:	\$28,429,184.75
Net Discount/(Premium):	309,094.64
Net Interest Cost:	<u>\$28,738,279.38</u>

Bond Years:	1,178,681
Average Coupon:	2.41195%
Average Life:	12.9854
Weighted Average Life:	12.9854
Net Interest Rate:	2.43817% @ 99.65947%
True Interest Cost:	2.40890% @ 99.65947%
Arbitrage Yield:	2.39552% @ 99.80565%

kcg

THRUN
LAW FIRM, P.C.



565 Branwood Circle
Suite 333
Ann Arbor, MI 48108

734.964.9700
734.964.9710 fax
www.pfm.com

LIVONIA PUBLIC SCHOOLS SCHOOL DISTRICT

Tax Base for Voted Bonds	Split Levy Tax Base
Taxable Value	100%
Plus Equivalent FT/CFT Valuation	
Total Tax Base	
Less TIFA/DDA Captures	
Net Tax Base	
For State Reimbursement related to Bonds Voted Prior to 2015	
Exempt Personal Property	

E.P.P. Reimbursable Mills: 4.10	2013 SCHOOL BUILDING AND SITE BONDS, SERIES I - UTNQ		2014 REFUNDING BONDS - UTNQ		2016 SCHOOL BUILDING AND SITE BONDS, SERIES II - UTNQ		2020 REFUNDING BONDS - UTNQ	Total Mills
	Yes	Yes	Yes	Yes	Yes	Yes		
Voted Prior to 2015:								
July Mills	0.570	0.950	0.950	0.530	0.000	0.000	2.050	
December Mills	0.570	0.950	0.950	0.530	0.000	0.000	2.050	
Re-Allocated Mills	-0.780	0.310	0.310	0.000	0.470	0.000	0.000	
Total Mills	0.360	2.210	2.210	1.060	0.470	0.470	4.100	

DEBT RETIREMENT FUND CASH FLOW

06/30/2020 Fund Balance	\$1,191,067	\$2,428,572	\$1,366,678	\$0	\$4,986,317
Debt Fund Contribution	(1,879,390)	(3,232,011)	0	0	(5,111,401)
Revenue from July '20 levy (92.0%)	785,181	4,820,139	2,311,922	1,025,097	8,942,339
State Reimbursement for July Levy	115,145	191,909	107,065	0	414,119
Balance prior to Nov. '20 Payments	\$212,003	\$4,208,609	\$3,785,665	\$1,025,097	\$9,231,374
11/01/20 Payment	(103,000)	(567,500)	(1,791,250)	0	(2,461,750)
11/02/20 Balance	\$109,003	\$3,641,109	\$1,994,415	\$1,025,097	\$6,769,624
Revenue from Dec. '20 levy (92.0%)	785,181	4,820,139	2,311,922	1,025,097	8,942,339
State Reimbursement for Dec. Levy	115,145	191,909	107,065	0	414,119
Balance prior to May '21 Payments	\$1,009,329	\$8,653,156	\$4,413,401	\$2,050,195	\$16,126,082
05/01/21 Payments	(1,003,000)	(7,972,500)	(3,166,250)	(1,998,189)	(14,139,939)
05/01/21 Transfer Agent Fees	(500)	(500)	(500)	(500)	(2,000)
05/02/21 Balance	\$5,829	\$680,156	\$1,246,651	\$51,506	\$1,984,143
Plus: County Delinq. Reimbursement (7.0%)*	136,553	838,285	402,073	178,278	1,555,189
06/30/21 Balance	\$142,383	\$1,518,442	\$1,648,725	\$229,784	\$3,539,333
Current Levy Cycle Debt Service	\$1,106,000	\$8,540,000	\$4,957,500	\$1,998,189	\$16,601,689
Ending Balance as % of Current Levy Cycle's Debt Service	12.87%	17.78%	33.26%	11.50%	21.32%
May 2nd Balance as % of Current Levy Cycle's Debt Service	0.53%	7.96%	25.15%	2.58%	11.95%
Next Levy Cycle Total Debt Service	\$1,061,000	\$8,574,750	\$4,963,750	\$1,888,195	\$16,487,695
Ending Balance as % of Next Levy Cycle's Debt Service	13.42%	17.71%	33.22%	12.17%	21.47%

EXHIBIT C



MUNICIPAL BOND INSURANCE COMMITMENT

ISSUER: Livonia Public Schools School District, Michigan
MEMBER: Livonia Public Schools School District, Michigan
Effective Date: September 21, 2020
Expiration Date: December 19, 2020
BONDS: 2020 Refunding Bonds (General Obligation - Unlimited Tax) (Federally Taxable) in aggregate principal amount not to exceed \$92,125,000
Net Insurance Payment: 0.148% of the Total Debt Service on the Bonds assuming a MSC Refunding Credit related to 2014 Bonds: \$2,405.33*

BUILD AMERICA MUTUAL ASSURANCE COMPANY (“BAM”) hereby commits, subject to the terms and conditions contained herein or added hereto, to issue its Municipal Bond Insurance Policy (the “Policy”) relating to the Bonds referenced above (the “Bonds”) issued by or on behalf of the Member. To keep this Commitment in effect after the Expiration Date set forth above, a written request for renewal must be submitted to BAM prior to such Expiration Date. BAM reserves the right to grant or deny a renewal in its sole discretion.

THE MUNICIPAL BOND INSURANCE POLICY SHALL BE ISSUED IF THE FOLLOWING CONDITIONS ARE SATISFIED:

1. The documents to be executed and delivered in connection with the issuance and sale of the Bonds (collectively, the “Security Documents”), shall not contain any untrue or misleading statement of a material fact and shall not fail to state a material fact necessary in order to make the information contained therein not misleading.
2. No event shall occur which would permit any underwriter or purchaser of the Bonds, otherwise required, not to be required to underwrite or purchase the Bonds on the date scheduled for the issuance and delivery thereof (the “Closing Date”).

*Preliminary. Member Surplus Contribution Refunding Credit (and resulting net insurance payment) - subject to change based on the actual principal amount of (i) BAM-insured bonds refunded and (ii) refunding Bonds insured by BAM.

3. As of the Closing Date, there shall have been no material omissions or material adverse changes in, as to or affecting (i) the Member or the Bonds, including, without limitation, the security for the Bonds or (ii) any disclosure document relating to the Bonds (including any financial statements and other information included or incorporated by reference therein) (the "Official Statement"), the Security Documents to be executed and delivered with respect to the Bonds, any project to be financed with the proceeds of the Bonds (if applicable), the legal opinions to be delivered in connection with the issuance and sale of the Bonds, or any other information submitted to BAM with respect to the issuance and sale of the Bonds, including the proposed debt service schedule of the Bonds, from information previously provided to BAM in writing.

4. The applicable Security Documents shall contain the document provisions set forth in Exhibit A hereto and shall be in form and substance acceptable to BAM. No variation shall be permitted therefrom except as specifically approved by BAM in writing prior to the Closing Date.

5. The Bonds shall contain no reference to BAM, the Policy or the insurance evidenced thereby except as may be approved in writing by BAM. BOND PROOFS SHALL BE APPROVED IN WRITING BY BAM PRIOR TO PRINTING. The Bonds shall bear a Statement of Insurance in the form found on BAM's website (www.buildamerica.com) and in Exhibit B hereto entitled "DOCUMENT, PRINTING AND DISCLOSURE INFORMATION FOR PUBLIC FINANCE TRANSACTIONS".

6. The Official Statement shall contain the language provided by BAM and only such other references to BAM as BAM shall supply or approve in writing, and BAM shall be provided with final drafts of any preliminary and final Official Statement at least two business days prior to printing/electronic posting. BAM SHALL BE PROVIDED WITH AN ELECTRONIC COPY OF THE OFFICIAL STATEMENT SEVEN (7) DAYS PRIOR TO CLOSING, unless BAM shall agree in writing to a shorter period.

7. BAM shall be provided with:

(a) Copies of all Security Document drafts prepared subsequent to the date of this Commitment (blacklined to reflect all revisions from previously reviewed drafts) for review and approval. Final drafts of such documents shall be provided at least three (3) business days prior to the issuance of the Policy, unless BAM shall agree in writing to a shorter period. Copies of all drafts of the Security Documents shall be delivered to the BAM contacts specified in Exhibit 1.

(b) Copies of any consulting reports, feasibility studies, rate reports, engineer's reports or similar expert reports for review and approval, along with any revisions thereto (blacklined to reflect all revisions from previously reviewed drafts). Final drafts of such documents shall be provided at least three (3) business days prior to the issuance of the Policy, unless BAM shall agree in writing to a shorter period.

(c) The amortization schedule for, and final maturity date of, the Bonds, which schedule shall be acceptable to BAM. Please be aware that BAM will only insure fixed rate Bonds.

(d) A No-Litigation Certificate or a description of any material pending litigation relating to the Member or the Bonds and any opinions BAM shall request in connection therewith.

(e) A description of any material change in the Member's financial position from and after the date of the financial statements provided to BAM.

(f) Executed copies of all Security Documents, the Official Statement and the various legal opinions delivered in connection with the issuance and sale of the Bonds (which shall be dated the Closing Date and which, except for the opinions of counsel relating to the adequacy of disclosure, shall be addressed to BAM or accompanied by a letter of such counsel permitting BAM to rely on such opinion as if such opinion were addressed to BAM), including, without limitation, the unqualified approving opinion of bond counsel, in form and substance satisfactory to BAM. The foregoing shall be in form and substance acceptable to BAM. (For your information, the form of legal opinion, primary market disclosure certificate and officer's certificate to be delivered by BAM at Closing is attached hereto as Exhibit C.)

(g) Evidence of wire transfer in federal funds of an amount equal to the Insurance Payment, unless alternative arrangements for the payment of such amount acceptable to BAM have been made prior to the Closing Date.

8. In the event the Bonds are sold in a private placement transaction, (i) BAM shall receive a closing certificate, in form and substance acceptable to BAM, covering the matters in Paragraphs 7 (d) and (e), (ii) the Issuer shall agree to provide BAM with continuing disclosure consistent with any Continuing Disclosure Agreement for any previously issued public debt of the Issuer (irrespective of whether or not that debt remains outstanding) or enter into such other agreement for continuing disclosure acceptable to BAM and (iii) the Issuer shall provide BAM with copies of all documents and agreements, including without limitation any term sheet, side agreement and/or purchase agreement, executed or delivered in connection with the Bonds, which documents and agreements shall be in form and substance acceptable to BAM.

9. Bonds must have an underlying, long-term rating of at least:

A	Standard and Poor's
NR	Moody's Investors Service

10. Promptly, but in no event more than thirty (30) days after the Closing Date, BAM shall receive a link to or PDF file of, or two (2) CD-ROMs of, the final closing transcript of proceedings, or if a link or PDF file cannot be provided or a CD-ROM is not available, such other electronic form as BAM shall accept.

11. To maintain this commitment until the Expiration Date set forth above, BAM must receive a copy of the signature page of this Commitment fully executed by an authorized officer of the undersigned by the earlier of the date on which the Official Statement containing disclosure language regarding BAM is circulated and ten (10) days after the date of this Commitment.

12. Standard & Poor's Ratings Services will separately present a bill for its fees relating to the Bonds. There is no incremental Standard & Poor's fee for the BAM-Insured rating. Payment of such bill by the Member should be made directly to such rating agency. Payment of the rating fee is not a condition to the release of the Policy by BAM.

REPRESENTATION AND AGREEMENT BY BAM

(a) BAM is a mutual insurance corporation organized under the laws of, and domiciled in, the State of New York.

(b) BAM covenants that it will only insure obligations of states, political subdivisions, an integral part of states or political subdivisions or entities otherwise eligible for the exclusion of income under Section 115 of the Internal Revenue Code of 1986, as amended, or any successor thereto.

(c) BAM covenants that it will not seek to convert to a stock insurance corporation.

(d) The issuance of the Policy qualifies the Member as a member of BAM until the Bonds are no longer outstanding. As a member of BAM, the Member is entitled to certain rights and privileges as provided in BAM's charter and by-laws and as may otherwise be provided under New York law, including the right to receive dividends if and when declared by BAM's Board of Directors. No dividends have been paid to date, and BAM has no current expectation that any dividends will be paid.

(e) The Policy is non-assessable and creates no contingent mutual liability.

(f) Refundings.

If (1) the Security Documents relating to the Bonds permit a legal defeasance (such that the bonds are no longer treated as outstanding under the Security Documents), (2) refunding bonds ("Refunding Bonds") will be issued for the purpose of legally defeasing such then outstanding BAM-insured Bonds (in this context, the "Refunded Bonds") and (3) upon their issuance (A) such Refunding Bonds have a final maturity date that is not later than the final Maturity Date of the Refunded Bonds, (B) the average annual debt service on the Refunding Bonds does not exceed the average annual debt service on the Refunded Bonds, and (C) the net proceeds of such Refunding Bonds are applied solely towards the legal defeasance of the Refunded Bonds and related costs of issuance, then, if BAM is requested to, and in its sole discretion determines to, offer a municipal bond insurance policy covering the Refunding Bonds (the "Refunding Policy") BAM will credit the then available Member Surplus Contribution for the Refunded Bonds against the insurance payment then charged with respect to the Refunding Bonds (proportionate to the amount of Refunding Bonds insured by BAM). If the Security Documents are silent on the matter of a legal defeasance, BAM may, in its sole and absolute discretion, accept such certificates, opinions and reports from or on behalf of the Member in connection with the issuance of such Refunding Bonds in order to establish to its satisfaction that the Refunding Bonds will be issued to retire the outstanding Refunded Bonds and that the Refunding Bonds comply with the criteria

set forth in clause (3) of the preceding sentence for the purpose of determining whether a supplemental Member Surplus Contribution is or is not required to be made at that time.

**BUILD AMERICA MUTUAL
ASSURANCE COMPANY**

A handwritten signature in black ink, appearing to be initials or a stylized name, positioned above a horizontal line.

Authorized Officer

September 21, 2020
Date

AGREED AND ACCEPTED

1. The undersigned agrees and accepts the conditions set forth above and further agrees that (i) if the Bonds (and any of the Bonds to be issued on the same date and for which BAM has issued a commitment) are insured by a policy of municipal bond insurance, such insurance shall be provided by BAM in accordance with the terms of this Commitment; (ii) it has made an independent investigation and decision as to whether to insure the payment when due of the principal of and interest on the Bonds and whether the Policy is appropriate or proper for it based upon its judgment and upon advice from such legal and financial advisers as it has deemed necessary; (iii) BAM has not made, and therefore it is not relying on, any recommendation from BAM that the Bonds be insured or that a Policy be obtained, it being understood and agreed that any communications from BAM (whether written or oral) referring to, containing information about or negotiating the terms and conditions of the Policy, and any related insurance document or the documentation governing the Bonds, do not constitute a recommendation to insure the Bonds or obtain the Policy; (iv) the undersigned acknowledges that BAM has not made any representation, warranty or undertaking, and has not given any assurance or guaranty, in each case, expressed or implied, as to its future financial strength or the rating of BAM's financial strength by the rating agency; (v) the undersigned acknowledges that a credit or claims-paying rating of BAM assigned by a Rating Agency reflects only the views of, and an explanation of the significance of any such rating may be obtained only from, the assigning Rating Agency, any such rating may change or be suspended, placed under review or withdrawn by such Rating Agency if circumstances so warrant, and BAM compensates a Rating Agency to maintain a credit or claims-paying ability rating thereon, but such payment is not in exchange for any specific rating or for a rating within any particular range; (vi) the undersigned acknowledges that BAM may in its sole and absolute discretion at any time request that a Rating Agency withdraw any rating maintained in respect of BAM; and (vii) BAM has made no representation that any dividend will be declared or paid while the Bonds are outstanding, the undersigned has no reason for expecting that any dividend will be declared or paid and the potential receipt of any dividend was not a reason for acquiring the Policy.

Notwithstanding anything to the contrary set forth herein, upon issuance of the Policy, the provisions set forth under subparagraphs (ii) through (vii) above and the representations and agreements of BAM shall survive the expiration or termination of this Commitment.

2. The undersigned member hereby appoints Jeffrey Fried, General Counsel of Build America Mutual Assurance Company ("Build America"), as proxy with the power to appoint his substitute, and hereby authorizes him to represent and to cast all of the votes to which the undersigned is entitled to cast as of the record date for the annual meeting of Build America members to be held on Tuesday, April 27, 2021, or at any adjournment or postponement thereof. This proxy is solicited on behalf of the management of Build America and will empower the holder to vote on the undersigned member's behalf for the election of members of the Board of Directors and such other business as may properly come before said annual meeting. This proxy can be revoked by giving Build America written notice of revocation (by email to generalcounsel@buildamerica.com, or by

U.S. mail or private carrier to General Counsel, Build America, 200 Liberty Street, New York, NY 10281) received by Build America on or before April 23, 2021. This proxy may also be revoked if the undersigned member attends the annual meeting and chooses to vote in person.

**LIVONIA PUBLIC SCHOOLS SCHOOL DISTRICT,
MICHIGAN**

By: _____
Authorized Officer

Date



**LIVONIA PUBLIC SCHOOLS
BOARD OF EDUCATION MEETING
September 28, 2020**

TOPIC: **Approval to Purchase Bulk Salt**

RECOMMENDATION:

Move that the Board of Education of the Livonia Public Schools School District approve the purchase of bulk road salt from the Detroit Salt Company, Detroit, Michigan, through the State of Michigan MiDEAL Extended Purchasing Program, for a total cost of \$75,030.00.

RATIONALE:

This purchase will provide necessary materials for parking lot and sidewalk winter maintenance.

BUDGETARY INFORMATION:

The source of funds for this purchase will be the General Fund.

RESOURCE PERSONNEL:

Phillip Francis, Director of Operations

EXHIBITS:

Attached

PF/ko



Date: September 16, 2020

To: Andrea Oquist, Superintendent

From: Phillip Francis, Director of Operations

Re: Bulk Salt Purchase

I would like to discuss the purchase of bulk road salt at the next Committee of the Whole meeting on Monday, September 21, 2020. This was originally discussed at the September 14, 2020 Study Session where the proposal to purchase was brought to the Board. The source of funds for this purchase is the General Fund.

We are proposing the purchase of 1,500 tons of road salt for the 2020-21 winter season, at a cost of \$50.02 per ton, for a total cost of \$75,030.00 from Detroit Salt Company via the MiDEAL Purchase Consortium. This is a decrease of \$2.36 per ton from last year.

The school district is required to purchase 80% of the road salt, which would be 1,200 tons, at a cost of \$60,024. The contract permits us to buy a percentage depending on the needs of the school district. If we have more inclement weather than the 1,500 tons can cover, we are allowed to purchase an additional 30% of bulk salt at our contract price.

The bulk road salt purchased for the last three winter seasons is listed below:

2017-18: Purchased 2,100 tons and used 1,700 tons

2018-19: Purchased 1,700 tons and used 1,500 tons

2019-20: Purchased 1,700 tons and used 1,500 tons

Please contact me if you have questions.

Attachment

PF/ko

c: Board of Education

**LIVONIA PUBLIC SCHOOLS
BOARD OF EDUCATION MEETING
September 28, 2020**

TOPIC: **Approval of Waste Removal Contract Extension**

RECOMMENDATION:

Move that the Board of Education of the Livonia Public Schools School District approve the recommendation to extend the current contract for districtwide waste removal services with Detroit Disposal and Recycling, Detroit, Michigan, with a 2% cost increase, for the 2020-2021 school year.

RATIONALE:

This service is for waste removal at all of the school district's buildings.

BUDGETARY INFORMATION:

General Fund

RESOURCE PERSONNEL:

Phillip Francis, Director of Operations

EXHIBITS:

Attached

PF/ko



Livonia Public Schools

Facilities and Operations

Date: September 10, 2020
To: Phillip Francis, Director of Operations
From: Harry C. Lau, Administrator of Facilities and Operations
Re: Recommendation to Extend the District Trash Collection for One Year

I am recommending and seeking approval to extend Livonia Public Schools' contract with Detroit Disposal for one year from today's date, September 10, 2020. The reason for this extension is the bidding atmosphere due to the pandemic is volatile.

Detroit Disposal is agreeable to the extension with a 2% cost of living increase. The price comparison is listed below.

<u>Container Size</u>	<u>Current Price</u>	<u>2020-21 Price</u>
6 yard container	\$ 8.74	\$ 8.92
8 yard container	\$11.49	\$11.72
10 yard container	\$14.39	\$14.68
20 yard open top	\$250.00 load	\$255.00 load
30 yard open top	\$275.00 load	\$280.00 load
40 yard open top	\$300.00 load	\$306.00 load

Thank you for your consideration in this matter.

cc: K. Oaks

**LIVONIA PUBLIC SCHOOLS
BOARD OF EDUCATION MEETING
September 28, 2020**

TOPIC: Approval to Purchase Pizza for School Meal Program

RECOMMENDATION:

Move that the Board of Education of the Livonia Public Schools School District approve the purchase of pizza from Pizza Hut, Livonia, Michigan in the amount of \$120,000.00 for the District's 2020-2021 School Lunch Program.

RATIONALE:

Pizza Hut has supplied the District with pizza lunches for the past two school years after being awarded the contract as the low responsible bidder. This is a continuation for the 2020-2021 school year.

BUDGETARY INFORMATION:

Costs are lower based on the number of students who will be in the Livonia Virtual School this year. The source of funds for these purchases will be the Food and Nutrition Services Fund.

RESOURCE PERSONNEL:

Phillip Francis, Director of Operations

EXHIBITS:

Attached

PF/ko



Date: September 16, 2020

To: Andrea Oquist, Superintendent

From: Phillip Francis, Director of Operations

Re: Purchase of Pizza for School Meal Program

I would like to discuss the Food and Nutrition Services purchase of pizza for the current school year at the next Committee of the Whole meeting on Monday, September 21, 2020. This was originally discussed at the September 14, 2020 Study Session.

Pizza Hut is our current pizza vendor for school meals. We entered into a three-year contract with them in September of 2018; they were the low responsible bidder at that time. This is the third year of that contract and we are recommending the pizza purchase in the amount of \$120,000.00 from the Food Service Fund for the 2020-21 school year. This number is lower than in the past, based on the students who will be in the Livonia Virtual School this year.

Please contact me if you have questions.

Attachment

PF/ko

c: Board of Education

**LIVONIA PUBLIC SCHOOLS
BOARD OF EDUCATION MEETING
September 28, 2020**

TOPIC: Purchase of Dairy Products for School Meal Program

RECOMMENDATION:

Move that the Board of Education of the Livonia Public Schools School District approve the purchase of milk and dairy supplies from Cedar Crest Dairy Inc., Hudsonville, Michigan in the amount of \$160,000.00 for the 2020-2021 school year.

RATIONALE:

Contract pricing was obtained through consortium bid pricing via HPS Group Purchasing Organization, which satisfies the Board's bid requirements.

BUDGETARY INFORMATION:

The source of funds for these purchases will be the Food Service Fund

RESOURCE PERSONNEL:

Phillip Francis, Director of Operations

EXHIBITS:

Attached

PF/ko



3275 N. M-37 Hwy.
 P.O. Box 247
 Middleville, MI 49333-0247
 800-632-4572
 hpsgpo.com

June 3, 2020

Rob Becker
 President
 Cedar Crest Dairy, Inc.
 5850 Balsam Dr. P.O. Box 38 Hudsonville, MI 49426-0038

Dear Rob,

By this letter, the HPS FSAAC, SFPAC, on behalf of HPS, notifies you that HPS is exercising its option to extend the term of the current HPS #434 (Rev. #3) for MILK AND DAIRY PRODUCTS (MI) that is due to expire on 6/30/2020 for an additional term beginning 7/1/2020 and ending 6/30/2021. All other terms and conditions of the Agreement remain in full force and effect, including without limitation your obligation to furnish HPS monthly or quarterly electronic statistical reports, via xls or txt format, concerning the purchases of each member/participant made pursuant to the Agreement (see item #19 on the Terms and Conditions sheet), and to pay HPS a recording fee equal to one tenth of one percent (.1%) for total sales.

Please acknowledge this extension by signing this form and returning it to HPS. Please feel free to contact me should you have any questions or require further information regarding this extension. HPS is looking forward to continuing this mutually beneficial arrangement.

Sincerely,

HPS

AGREED: Cedar Crest Dairy, Inc.

NAME: Christina Costanza

NAME: Rob Becker

TITLE: Contract Portfolio Analyst

TITLE: President

DATE: 6/08/2020

DATE: 6/4/2020

SIGNATURE: 

SIGNATURE: 

CC/tm Enclosures: Current Contract, Terms & Conditions Sheet



3275 N. M-37 Highway • P.O. Box 247
Middleville, MI 49333-0247
(800) 632-4572
www.hpsnet.com

EXHIBIT B

June 14, 2017

Rob Becker
President
Cedar Crest Dairy, Inc.
5850 Balsam Drive, PO Box 38
Hudsonville, MI 49426

RE: HPS MASTER GROUP AGREEMENT #434 (REV. #3) - Milk & Dairy Products (MI)

Dear Rob:

This is to advise you that your Company's proposal on Milk & Dairy Products (MI) for HPS's member/participant institutions, was accepted as best proposal by the HPS School Food Purchasing/Food Service Adm. Advisory Committee. As used in this Master Group Agreement, "HPS," "we," "us," and "our" refer to HPS LLC, a Delaware nonprofit limited liability company, and its subsidiary, HPS MI, Inc., a Delaware nonprofit corporation, as their interests may appear. We accept this proposal under the terms and conditions as set forth in the HPS Request for Proposals, including all its Appendices and Exhibits, and your proposal dated 4/19/2017. As the successful vendor, you are expected to follow up with planned visits to each eligible HPS member/participant to explain the program and pass along literature. Furthermore, if prices are available through distributors, it will be your responsibility to inform all distributors of the HPS pricing prior to the effective date of this Master Group Agreement. It will also be your responsibility to notify distributors of any future price changes in a like manner.

REPORTS TO HPS:

As per your response to item #19 on the Terms and Conditions sheet on your proposal, we will expect to receive your first dollar volume electronic report by participating institution to the HPS Office on or before 8/15/2017, via XLS or TXT file format. Also, you are responsible for dollar volume reports whether purchases are made via a distributor or direct.

You agree to pay HPS a recording fee equal to one tenth of one percent (.1%) of Total Sales, due thirty (30) days after each quarter or month (depending on how you report). For purposes of this Master Group Agreement, "Total Sales" means your gross sales to our members and participants (or to member's or participant's representatives including affiliates, subsidiaries, subcontractors, contractors, agents or other representatives) net of any discounts and return credits within the same reporting period. Any recording fee paid after the effective date of this Master Group Agreement is final, and not subject to be offset, nor will future adjustments be made for returns of vendor product purchases made by HPS members/participants. HPS will allocate recording fees between HPS LLC (for tax-exempt, nonprofit member activity) and HPS MI, Inc. (for taxable, for-profit participant activity), as appropriate.

Any payment due hereunder must be submitted with the corresponding electronic statistical dollar volume report. Should you be unable to meet this commitment for any reason, you must pay interest on the outstanding amount, accruing on a daily basis from and after the due date until any

outstanding amount has been paid in full, at a rate equal to the prime rate of interest announced by Comerica Bank, Grand Rapids, MI, plus two percent (2%).

Payment for recording fee payment to HPS can be made by electronic funds transfer (EFT). Call the HPS accounting department at 269-795-3308 for details regarding EFT payment information. An alternative payment method is by check made payable to HPS and mailed to 3275 N. M37 Hwy., P.O. Box 247, Middleville, MI 49333-0247.

Please provide HPS with an electronic version of all applicable agreement information including price list, commitment form, etc. in either Microsoft Word or Microsoft Excel.

AVAILABILITY: You guarantee availability of Milk & Dairy Products (MI) for duration of this Master Group Agreement.

The initial term of this Master Group Agreement is two (2) years, commencing on the date stated on the contract summary sheet that we will provide for your signature. We have the option to extend the term for up to two (2) additional periods of two (2) years each, by written notice to you before expiration of the then-current term.

Any current or future HPS Institution (as defined in the Request for Proposals) may make purchases under this Master Group Agreement upon entering into an Individual Member/Participant Agreement with you referencing this Master Group Agreement, as more fully described in the Request for Proposals. This Master Group Agreement may be terminated by us by giving 60 days written notice of such termination to you. Except as otherwise provided below, termination of this Master Group Agreement will constitute termination of all Individual Member/Participant Agreements executed by and between you and any participating HPS Institution pursuant to this Master Group Agreement. Any participating HPS institution also may terminate its participation under this Master Group Agreement and any Individual Member/Participant Agreement by giving you 60 days written notice of such termination. If this Master Group Agreement is terminated by HPS, a participating HPS institution may elect to continue its existing Individual Agreement with you pursuant to the existing terms and conditions of the Individual Agreement. If a participating HPS institution elects to continue its Individual Agreement with you, the participating HPS institution will notify you in writing of this election within 30 days of the termination of this Master Group Agreement and the Individual Member Agreements by HPS.

Your agreement with HPS includes this Master Group Agreement, the Request for Proposals, the Appendices, Exhibits, and other documents identified in the Request for Proposals, and your proposal, all of which are incorporated into this Master Group Agreement in the order of priority set forth in the Request for Proposals. Your agreement with the foregoing will be indicated by your signing and returning to us a copy of this Master Group Agreement. Please be advised that HPS will not send notice of this Master Group Agreement to our member/participant institutions until a signed copy of this Master Group Agreement copy has been received in our office. Therefore, it is imperative that this document be signed and returned to my attention at your earliest convenience. You may not assign this Master Group Agreement, by operation of law or otherwise, without the prior written consent of HPS.

We look forward to a mutually beneficial relationship between your company and our member/participant institutions.

Sincerely,

Katie Hayward

Katie Hayward
Contract Analyst
KH/tm

AGREED: Cedar Crest Dairy, Inc.

NAME: *Pat Barber*

TITLE: *Proc*

DATE: *8/15/17*

**LIVONIA PUBLIC SCHOOLS
BOARD OF EDUCATION MEETING
September 28, 2020**

TOPIC: Approval of School Meal Program Vendor

RECOMMENDATION:

Move that the Board of Education of the Livonia Public Schools School District approve the recommendation of Van Eerden Foodservice Company, Grand Rapids, Michigan, to supply the district with food items and non-food products for the 2020-2021 school year in an amount not to exceed \$1,250,000.00.

RATIONALE:

Van Eerden Food Service is the local distributor for the MOR Cooperative, which has been awarded both the distribution bid and the manufacturer direct food and supply bid by Wayne County RESA and approved by the Michigan Department of Education (MDE).

BUDGETARY INFORMATION:

The source of funds for this purchase will be the Food Service Fund.

RESOURCE PERSONNEL:

Phillip Francis, Director of Operations

EXHIBITS:

Attached

PF/ko



Date: September 16, 2020
To: Andrea Oquist, Superintendent
From: Phillip Francis, Director of Operations
Re: Approval of School Meal Program Vendor

I would like to request adding an agenda item to the Monday, September 21, 2020 Committee of the Whole meeting to discuss the approval of Van Eerden Foodservice as the District's meal program distributor to provide food and non-food supplies for the 2020-21 school year in the amount of \$1,250,000.00 from the Food Service Fund.

Van Eerden Foodservice is the local distributor for the MOR Cooperative, which has been awarded both the distribution bid and the manufacturer direct food and supply bid by Wayne County RESA and approved by the Michigan Department of Education (MDE). This satisfies the Board's bid requirement.

Please let me know if there are any questions. Thank you.

PF/ko

Attachment

c: Board of Education

**LIVONIA PUBLIC SCHOOLS
BOARD OF EDUCATION MEETING
September 28, 2020**

TOPIC: Approval to Purchase Technology for School Meal Program

RECOMMENDATION:

Move that the Board of Education of the Livonia Public Schools School District approve the purchase of computers, monitors and scanners for the Food and Nutrition Service Department from CDW-G, Vernon Hills, Illinois in the amount of \$75,809.00.

RATIONALE:

This technology package is a required update to all of the schools' kitchens in order to continue the use of the Point of Sale (POS) system the District utilizes. The current system runs on Windows 7, which is an outdated operating system. This technology package is required in order to continue to use the POS software system utilized by the department in all schools.

BUDGETARY INFORMATION:

The source of funds for this purchase will be the Food Service Fund

RESOURCE PERSONNEL:

Phillip Francis, Director of Operations

EXHIBITS:

Attached.

PF/ko

QUOTE CONFIRMATION



DEAR TYLER DUNCAN,

Thank you for considering CDW•G for your computing needs. The details of your quote are below. [Click here](#) to convert your quote to an order.

QUOTE #	QUOTE DATE	QUOTE REFERENCE	CUSTOMER #	GRAND TOTAL
LPRJ002	8/25/2020	FOOD SERVICES 800 MINI	1271134	\$75,809.00

QUOTE DETAILS				
ITEM	QTY	CDW#	UNIT PRICE	EXT. PRICE
BTO HP 800 G5 I5-9600T 256/8 WP Mfg. Part#: 33010117 Contract: REMC Supplies, Furniture & Technology 2019 (2019 Supplies, Furn&Tech)	43	6210325	\$690.00	\$29,670.00
Elo 2202L - LCD monitor - Full HD (1080p) - 22" Mfg. Part#: E351600 UNSPSC: 43211902 Contract: REMC Supplies, Furniture & Technology 2019 (2019 Supplies, Furn&Tech)	43	4967202	\$449.00	\$19,307.00
Kensington MicroSaver 2.0 Keyed Laptop Lock - Master security cable Mfg. Part#: K65042 UNSPSC: 43211612 Contract: REMC Supplies, Furniture & Technology 2019 (2019 Supplies, Furn&Tech)	43	4536467	\$39.00	\$1,677.00
Elo Extended Warranty - extended service agreement - 4 years - shipment Mfg. Part#: E894921 UNSPSC: 81112307 Electronic distribution - NO MEDIA Contract: REMC Supplies, Furniture & Technology 2019 (2019 Supplies, Furn&Tech)	43	5546583	\$89.00	\$3,827.00
HP ESP Only HP e-Care Pack Next Business Day Hardware Support Mfg. Part#: U7899E UNSPSC: 81111812 Electronic distribution - NO MEDIA Contract: REMC Supplies, Furniture & Technology 2019 (2019 Supplies, Furn&Tech)	43	585482	\$89.00	\$3,827.00
Genovation MiniTerm 905 - keypad - with display, barcode scanner - light gr Mfg. Part#: 905-S UNSPSC: 43211706 Contract: REMC Supplies, Furniture & Technology 2019 (2019 Supplies, Furn&Tech)	43	2231230	\$335.00	\$14,405.00
APC Back-UPS ES 550VA UPS Mfg. Part#: BE550G UNSPSC: 26111701 Contract: REMC Supplies, Furniture & Technology 2019 (2019 Supplies, Furn&Tech)	43	1524034	\$72.00	\$3,096.00

PURCHASER BILLING INFO	SUBTOTAL	\$75,809.00
Billing Address: LIVONIA PUBLIC SCHOOLS ACCTS PAYABLE 15125 FARMINGTON RD LIVONIA, MI 48154-5474 Phone: (734) 523-9164 Payment Terms: NET 30-VERBAL	SHIPPING	\$0.00
	SALES TAX	\$0.00
	GRAND TOTAL	\$75,809.00
	Please remit payments to:	
DELIVER TO	CDW Government 75 Remittance Drive Suite 1515 Chicago, IL 60675-1515	
Shipping Address: LIVONIA PUBLIC SCHOOLS TYLER DUNCAN 15125 FARMINGTON RD LIVONIA, MI 48154-5474 Shipping Method: UPS Ground (1- 2 day)		

Need Assistance? CDW•G SALES CONTACT INFORMATION

	Jesse Hafterson		(866) 809-9887		jesshaf@cdwg.com
---	-----------------	--	----------------	--	------------------

This quote is subject to CDW's Terms and Conditions of Sales and Service Projects at <http://www.cdwg.com/content/terms-conditions/product-sales.aspx>
For more information, contact a CDW account manager

© 2020 CDW•G LLC, 200 N. Milwaukee Avenue, Vernon Hills, IL 60061 | 800.808.4239

**LIVONIA PUBLIC SCHOOLS
BOARD OF EDUCATION MEETING
September 28, 2020**

TOPIC: Approval to Purchase Thermal Monitoring and Control Systems

RECOMMENDATION:

Move that the Board of Education of the Livonia Public Schools School District approve the purchase of Thermal Monitoring and Control Systems from Global Office Solutions, Novi, Michigan, for a total cost of \$37,485.00.

RATIONALE:

This purchase will provide machines that take touchless body temperatures via the wrist. These will be utilized at all building entry points, including Central Office. Pricing is through the Michigan Association of Counties/Collaborative Procurement + more (MAC/CoPro+), which satisfies the Board's bid requirement.

BUDGETARY INFORMATION:

The source of funds for this purchase will be the General Fund.

RESOURCE PERSONNEL:

Phillip Francis, Director of Operations

EXHIBITS:

Attached

PF/ko



Global Office Solutions
 22759 Heslip Drive
 Novi, MI 48375
 Phone 800-331-8990
 Fax 248-449-9101

SALES QUOTE

Innovative solutions. Precise execution.



Sales Quote Number Q109455

Sales Quote Date 09/10/20

Page 1

Sell
 To Livonia Public Schools
 CANDY WELDON
 15125 FARMINGTON RD
 ACCOUNTS PAYABLE
 LIVONIA, MI 48154

Ship
 To LIVONIA PUBLIC SCHOOLS
 Harry Lau
 15125 FARMINGTON RD
 LIVONIA, MI 48154
 (734) 744-2500

Ship Via

Customer ID 4137

Terms Net 30 Days

SalesPerson 960

Item No.	Description	Unit	Quantity	Unit Price	Total Price
GOSTMPS1	Thermo Pass Infrared	Each	63	595 00	37,485 00
	Non Refundable MUST HAVE PO				

Amount Subject to Sales Tax	0.00	Amount Exempt from Sales Tax	37,485.00	Subtotal	37,485.00
				Invoice Discount	0 00
				Total Sales Tax:	0 00
			56	Total	37,485 00

Proposal



Proposal #: 16199.LIV092020

Please refer to this number when ordering

Date: 8/10/2020

Bill To: _____ **Ship To:** _____ **From:** _____

PHILLIP FRANCIS / DIRECTOR OF OPERATIONS

Account #: 413983
 LIVONIA PUBLIC SCHOOLS
 15125 FARMINGTON RD
 LIVONIA, MI 48154-5474
 Phone: 734-523-9164
 Fax: 734-523-0012
 Email: pfrancis@livoniapublicschools.org

Account #: 169898
 LIVONIA PS WAREHOUSE
 15125 FARMINGTON RD
 LIVONIA, MI 48154-5413
 Phone: 734-523-9164
 Attn: PHILLIP FRANCIS

Jill McCrie
 Phone: (734) 255-0930
 Fax: (920) 882-4472
 Jill.McCrie@schoolsspecialty.com
 Territory No: 16199/117

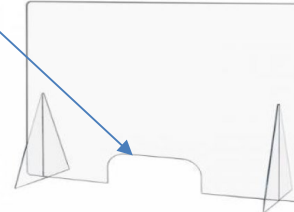
				Valid for 10 Days		
Item #	Qty	Page	Description	List Price	Your Price	Amount
XXXXXX	500	#N/A	ELKAY ACRYLIC PROTECTIVE BARRIER SINGLE PANEL DESK OR TABLETOP. 36"W X 27"H. 1/4" T CLEAR ACRYLIC, ROUNDED CORNERS, FRAMELESS, SPECIFY: WITH OR WITHOUT PASS-THRU FLAT PACKED FOR SITE ASSEMBLY BY OTHERS. COMMERCIAL GRADE VELCRO IS INCLUDED, BUT NOT REQUIRED*** LEAD TIME: 4 WEEKS AEPA COOPERATIVE BID AWARD PRICING REFERENCE IFB018-D DELIVERED PRICING - INCLUDES FREIGHT (BASED ON QTY)	\$113.00	\$68.93	\$34,465.00
				<div style="border: 1px solid black; padding: 5px;"> ***THIS PRODUCT IS DESIGNED TO BE PORTABLE. VELCRO MOUNTS PROVIDED FOR </div> 		
Customer Phone 1-888-388-3224				Page 1 TOTAL		\$34,465.00
Service: FAX: 1-888-388-6344 orders@schoolsspecialty.com				TOTAL All Pages		\$34,465.00

PROPOSAL QUALIFICATIONS

PRICES FIRM TO: 8/20/2020	SHIPMENT BY: Best Way	<input checked="" type="checkbox"/> DELIVERED PRICING	Installation:
SHIP BY:	INVOICE TERMS: Net 30	<input checked="" type="checkbox"/> Tailgate Delivery Only	<input checked="" type="checkbox"/> by owner
		<input type="checkbox"/> Lift Gate Truck Required	<input type="checkbox"/> by S.S.
		<input type="checkbox"/> Inside Delivery	<input type="checkbox"/> other
		<input checked="" type="checkbox"/> One Location	
		<input type="checkbox"/> Multiple Locations	

© 2015 School Specialty, Inc.

• THIS PROPOSAL AFFORDS **SPECIAL ONE-TIME PRICING** FOR THE PRODUCTS AND QUANTITIES LISTED

• **TO GUARANTEE PRICE(S) PROPOSED THIS FORM MUST ACCOMPANY YOUR ORDER**

• IF ANY QUANTITIES ARE CHANGED, PRICES WILL BE SUBJECT TO RENEGOTIATION

• PRICES PROPOSED ARE ONLY VALID UNTIL THE EXPIRATION DATE SHOWN

Proposed By: Jill McCrie

Title: Strategic Account Manager

**LIVONIA PUBLIC SCHOOLS
BOARD OF EDUCATION MEETING
September 28, 2020**

TOPIC: Approval to Purchase Folding Chairs and Storage Dollies - 2013 Bond

RECOMMENDATION:

Move that the Board of Education of the Livonia Public Schools School District approve the purchase of folding chairs and folding chair dollies from School Specialty, Chicago, Illinois in the amount of \$50,769.43.

RATIONALE:

The chairs and folding chair dollies are used throughout the District for various school activities. Pricing comes from the REMC bid award, which satisfies the Board's bid requirement.

BUDGETARY INFORMATION:

The source of funds for this purchase will be the 2013 Bond.

RESOURCE PERSONNEL:

Phillip Francis, Director of Operations

EXHIBITS:

Attached

PF/ko

Proposal



Proposal #: 16199.LIV072320.r2

Please refer to this number when ordering

Date: 8/14/2020
Bill To:



Ship To:

From:

HARRY LAU
Account #: 413983
LIVONIA PUBLIC SCHOOLS
15125 FARMINGTON RD
LIVONIA, MI 48154-5474
Phone: 734-523-9164
Fax: 734-523-0012
Email: hlau@livoniapublicschools.org

Account #: 169898
LIVONIA PS WAREHOUSE
15125 FARMINGTON RD
LIVONIA, MI 48154-5413
Phone: 734-523-9164
Attn: HARRY LAU

Jill McCrie
Phone: (734) 255-0930
Fax: (920) 882-4472
Jill.McCrie@schoolsspecialty.com
Territory No: 16199/117

				Valid for 30 Days		
Item #	Qty	Page	Description	List Price	Your Price	Amount
<u>FOLDING CHAIRS & DOLLIES</u>						
2009333	1300	-	NPS 600 SERIES LIGHTWEIGHT FOLDING CHAIR, CHARCOAL SLATE WITH SILVERTONE FRAME (620) 300 LB WEIGHT CAPACITY	\$58.28	\$34.39	\$44,707.00
						
677299	33	405 - 278	DY50 VERTICAL STORAGE FOLDING CHAIR DOLLY. CAPACITY OF 40 600 SERIES FOLDING CHAIRS	\$357.41	\$183.71	\$6,062.43
						
				REMC BID AWARD PRICING BID # 7788609700 DELIVERED PRICING - INCL. FREIGHT		
				You Saved: \$36,789.10		
Customer Phone 1-888-388-3224				Page 1 TOTAL		\$50,769.43
Service: FAX: 1-888-388-6344 orders@schoolsspecialty.com				TOTAL All Pages		\$50,769.43

PRICES FIRM TO:			SHIPMENT BY:		DELIVERED PRICING		Installation:	
10/13/2020			Best Way		<input checked="" type="checkbox"/> Tailgate Delivery Only		<input checked="" type="checkbox"/> by owner	
SHIP BY:			INVOICE TERMS:		<input type="checkbox"/> Lift Gate Truck Required		<input type="checkbox"/> by S.S.	
			Net 30		<input type="checkbox"/> Inside Delivery		<input type="checkbox"/> other	
					<input checked="" type="checkbox"/> One Location			
					<input type="checkbox"/> Multiple Locations			

© 2015 School Specialty, Inc.

- THIS PROPOSAL AFFORDS **SPECIAL ONE-TIME PRICING** FOR THE PRODUCTS AND QUANTITIES LISTED
- TO GUARANTEE PRICE(S) PROPOSED **THIS FORM MUST ACCOMPANY YOUR ORDER**
- IF ANY QUANTITIES ARE CHANGED, PRICES WILL BE SUBJECT TO RENEGOTIATION
- PRICES PROPOSED ARE ONLY VALID UNTIL THE EXPIRATION DATE SHOWN

Proposed By: Jill McCrie

Title: Strategic Account Manager

**LIVONIA PUBLIC SCHOOLS
BOARD OF EDUCATION MEETING
September 28, 2020**

TOPIC: Approval to Purchase Choral Risers – 2013 Bond

RECOMMENDATION:

Move that the Board of Education of the Livonia Public Schools School District approve the purchase of choral risers from School Specialty, Chicago, Illinois in the amount of \$81,166.59.

RATIONALE:

Choral risers are used throughout the District for various school performances. Pricing comes from the REMC bid award, which satisfies the Board's bid requirement.

BUDGETARY INFORMATION:

The source of funds for this purchase will be the 2013 Bond.

RESOURCE PERSONNEL:

Phillip Francis, Director of Operations

EXHIBITS:

Attached

PF/ko

Proposal



Proposal #: 16199.072720.r2-RISERS

Please refer to this number when ordering

Date: 8/14/2020

Bill To: _____ **Ship To:** _____ **From:** _____

HARRY LAU

Account #: 413983
LIVONIA PUBLIC SCHOOLS
15125 FARMINGTON RD
LIVONIA, MI 48154-5474
Phone: 734-523-9164
Fax: 734-523-0012
Email: hlau@livoniapublicschools.org

Account #: 169898
LIVONIA PS WAREHOUSE
15125 FARMINGTON RD
LIVONIA, MI 48154-5413
Phone: 734-523-9164
Attn: HARRY LAU

Jill McCrie
Phone: (734) 255-0930
Fax: (920) 882-4472
Jill.McCrie@schoolsspecialty.com
Territory No: 16199/117

Valid for 30 Days

Item #	Qty	Page	Description	List Price	Your Price	Amount
1283517	3	405 - 90	NPS TRANSPORT PORTABLE CHORAL RISER, 60"L X 54"D X 24"H, TAPERED. MOBILE FOR TRANSPORT & QUICK SET-UP DBL WALLED EXTRUDED ALUMINUM FRAME 3/4" PLYWOOD, GREY CARPETED PLATFORM	\$1,353.77	\$812.26	\$2,436.78
1283518	3	405 - 90	TAPERED TRANSPORT FOLDABLE CHORAL BACK GUARD RAIL FOR 3 LEVEL RISER	\$237.09	\$142.25	\$426.75
1442293	2	405 - 90	SIDE GUARD RAIL FOR 3 LEVEL RISER	\$118.87	\$71.32	\$142.64
EACH 3-SECTION TAPERED RISER SET >>>						\$3,006.17



Customer Phone 1-888-388-3224 **x 27 SETS = \$81,166.59**
Service: FAX: 1-888-388-6344 **TOTAL All Pages \$81,166.59**
orders@schoolsspecialty.com

PROPOSAL QUALIFICATIONS

PRICES FIRM TO: 10/13/2020 SHIP BY:	SHIPMENT BY: Best Way INVOICE TERMS: Net 30	<input checked="" type="checkbox"/> DELIVERED PRICING <input checked="" type="checkbox"/> Tailgate Delivery Only <input type="checkbox"/> Lift Gate Truck Required <input type="checkbox"/> Inside Delivery <input checked="" type="checkbox"/> One Location <input type="checkbox"/> Multiple Locations	Installation: <input checked="" type="checkbox"/> by owner <input type="checkbox"/> by S.S. <input type="checkbox"/> other
---	--	---	--

© 2015 School Specialty, Inc.

- THIS PROPOSAL AFFORDS **SPECIAL ONE-TIME PRICING** FOR THE PRODUCTS AND QUANTITIES LISTED
- **TO GUARANTEE PRICE(S) PROPOSED THIS FORM MUST ACCOMPANY YOUR ORDER**
- IF ANY QUANTITIES ARE CHANGED, PRICES WILL BE SUBJECT TO RENEGOTIATION
- PRICES PROPOSED ARE ONLY VALID UNTIL THE EXPIRATION DATE SHOWN

Proposed By: Jill McCrie

Title: Strategic Account Manager

LIVONIA PUBLIC SCHOOLS
 Teachers for Board Approval
 September 28, 2020

Name	Degree/School	Assignment	Experience	
Abel, Macy	Bachelor of Arts Elementary Education & Language Arts Michigan State University	(1.0) Elementary Teacher Riley Upper Elementary August 31, 2020	Substitute Teacher Waterford School District	4 months
Adams, Kristy	Bachelor of Science in Elementary Education Eastern Michigan University	(1.0) Elementary Teacher Johnson Upper Elementary August 31, 2020	Substitute Teacher EDUStaff Pompon Head Coach Plymouth Canton Community Schools Pompon Head Coach Garden City Public Schools	2 years 4 years 4 years
Bagian, Peggy	Master of Education Literacy Studies Grand Valley State University Bachelor of Science Elementary Education & Mathamatics Eastern Michigan University	(1.0) Elementary Teacher Cooper Upper Elementary August 31, 2020	5th Grade Teacher Eastridge Elementary - Aurora, CO 4th Grade Math Teacher Washington Parks - Redford Charter Twp. 4th Grade Teacher Golden Acres Elementary - Pasadena, TX	3 years 2 years 2 years
Berman, Madison	Bachelor of Arts Elementary Education & Social Studies Michigan State University	(1.0) Elementary Teacher Cooper Upper Elementary August 31, 2020	Student Teacher Intern Southfield Public Schools	8 months
Birchmeier, Chelsea	Master of Arts Secondary Tecacher Education U of M Ann Arbor Bachelor of Arts English Literature & History U of M Ann Arbor	(1.0) Secondary ELA Teacher Churchill High School September 3, 2020	Skyline High School English Teacher Ann Arbor Public Schools Teacher Wayne Westland Community Schools	1 year 5 years
Bixler, Olivia	Bachelor of Science Elementary Education Eastern Michigan University	(1.0) Elementary Teacher Webster Elementary August 31, 2020	Lead Teacher Bemis Farms PreSchool & Childcare	2 years
Bone, Casey	Bachelor of Science Elementary Education Eastern Michigan University	(1.0) Elementary Teacher Cleveland Elementary August 31, 2020	Long-term Substitute-Bird Elementary EDUStaff Premier Substitute EDUStaff	6 months 5 months

LIVONIA PUBLIC SCHOOLS
Teachers for Board Approval
September 28, 2020

Name	Degree/School	Assignment	Experience
Brown, Brittany	Bachelor of Science Elementary Education Eastern Michigan University	(1.0) Elementary Teacher Buchanan Elementary August 31, 2020	Substitute Teacher EDUStaff 3 months
Brown, Kelly	Bachelor of Science Early Childhood Education Western Michigan University	(1.0) Elementary Teacher Johnson Upper Elementary September 2, 2020	Teacher Warrendale Charter Academy - Detroit 2 years
Cadotte, Elizabeth	Bachelor of Arts Social Relations & Policy Secondary Social Studies & History Michigan State University	(1.0) Secondary Social Studies Frost Middle School August 31, 2020	Student Teacher Everett High School - Lansing Student Innovation Team Member Michigan State University The hub for Innovation, Learning & Tech. 5 months 1 year
Ciuffetelli, Thomas	Bachelor or Arts Physical Education Eastern Michigan University	(1.0) PE Teacher Frost Middle School August 31, 2020	PE Teacher Redford Union Schools 14 years
Cleveland, Eleanor	Bachelor of Arts Special Education - Learning Disabilities Michigan State University	(1.0) Elementary Teacher Johnson Upper Elementary August 31, 2020	Youth Volunteer Corps Coordinator YMCA Camp Director YMCA 6 months 1 year
Collins, Nicole	Master of Arts in Teaching Curriculum & Instruction Marygrove College Bachelor of Science Social Studies & Political Science Eastern Michigan University	(1.0) Secondary Social Studies Churchill High School August 31, 2020	Support Services & Social Studies Teacher Arts Academy in the Woods 13 years
Conley, Tracy	Master of Arts Educational Meda & Technology Eastern Michigan University Bachelor of Arts Elementary Education U of M - Dearborn	(1.0) Elementary Teacher Riley Upper Elementary September 2, 2020	5th Grade Teacher Melvindale-Northern Allen Park Schools Substitute Teacher PESG Substitute Teacher EDUStaff 3 years 1 year 1 year

LIVONIA PUBLIC SCHOOLS
 Teachers for Board Approval
 September 28, 2020

Name	Degree/School	Assignment	Experience
Culp, Jaclynn	Bachelor of Science Elementary Education & Social Studies Eastern Michigan University	(1.0) Elementary Teacher Roosevelt Elementary August 31, 2020	Substitute Teacher EDUStaff 2 years
Currie, Sara	Master of Arts Education/Curriculum & Instruction University of Phoenix, MA Bachelor of Science Elementary Education Triple minor in Math, Science & Behavior Eastern Michigan University	(1.0) Elementary Teacher Roosevelt Elementary August 31, 2020	1st. Grade Teacher Ecorse Public Schools 1st. Grade, 3rd. Grade & Kidergarten Teacher National Heritage Academies 3 years 9 years
Drolet, Angela	Master of Education Special Education & Learning Disabilities U of M - Dearborn Bachelor of Arts Early Childhood Education & Mathematics & Science U of M - Dearborn	(1.0) Elementary Teacher Buchanan Elementary August 31, 2020	Teacher South Lyon Community Schools Teacher West Bloomfield Schools 5 years 2 years
Duffy, Alicia	Master of Arts School Psychology University of Detroit Mercy Bachelor of Science Psychology/Social Work Eastern Michigan University	(1.0) School Psychologist Student Services September 8, 2020	School Psychologist Taylor Public Schools School Psychologist St. Joseph County ISD 1 year 3 years
Durand, Amanda	Master of Arts Social Work Wayne State University Bachelor of Science Social Work	(1.0) Social Worker Student Services 31-Aug-20	Substitute Paraprofessional EDUStaff 2 years
Elwood, Rebecca	Bachelor of Arts Early Childhood Education & Elementary Education Eastern Michigan University	(1.0) Elementary Teacher Randolph Elementary August 31, 2020	Elementary Teacher Aiken County Public Schools Graniteville, SC 3 years

LIVONIA PUBLIC SCHOOLS
 Teachers for Board Approval
 September 28, 2020

Name	Degree/School	Assignment	Experience	
Field, Heather	Master of Education Reading Specialist Grand Valley State University	(1.0) Elementary Teacher Randolph Elementary August 31, 2020	3rd. Grade Teacher Huron Valley Public Schools	1 year
	Bachelor of Arts Elementary Education & English Hope College		1st. Grade Teacher West Ottawa Public Schools	7 years
Filiatraut, Janice	Master of Education Marygrove College	(1.0) Elementary Teacher Hoover Elementary August 31, 2020	Curriculum Coordinator St. Michael Elementary	2 years
	Bachelor of Science Elementary Education		STEM/Enrichment Prog. Coordinator/Instructor St. Michael Elementary	3 years
	Eastern Michigan University		2nd. Grade Teacher	10 years
			St. Michael Elementary Elementary Tutor Teacher Livonia Public Schools	5 years 6 years
Flannigan, Melissa	Bachelor of Science Secondary Math & Physics Saginaw Valley State University	(1.0) Secondary Math Teacher Franklin High School September 3, 2020	Student Teacher Clifford Smart Middle School - Commerce MI	1 year
			Substitute Teacher EDUStaff	2 years
Gallagher, Kristin	Bachelor of Science Elementary Education & Early Childhood	(1.0) Elementary Teacher Rosedale Elementary August 31, 2020	Student Teacher Ferndale Lower Elementary School	5 months
	Wayne State University		Head Camp Counselor Camp Mirage - Plymouth MI	3 years
Genord, Haylie	Bachelor of Science Elementary Education & Early Childhood	(1.0) Elementary Teacher Randolph Elementary August 31, 2020	Student Teacher South Lyon Schools	4 months
	Eastern Michigan University		Substitute Teacher South Lyon Schools	1 year

LIVONIA PUBLIC SCHOOLS
 Teachers for Board Approval
 September 28, 2020

Name	Degree/School	Assignment	Experience
Griffith, Kimberly	Master of Teaching Physical Education & Health Wayne State University Bachelor of Arts Communication Sciences & Disorders Wayne State University	(1.0) Physical Education Teacher Frost Middle School August 31, 2020	PE Teacher Waterford Schools Special Education Paraprofessional Livonia Public Schools 1 year 2 years
Held, Heather	Bachelor of Science Special Education & Language Arts Western Michigan University	(1.0) Resource Room Teacher Cooper Upper Elementary August 31, 2020	Special Education Teacher Brandon School District 5 years
Kernan, Kristine	Master of Science in Nursing University of Detroit Mercy Bachelor of Science in Nursing Oakland University	(1.0) Health Science Teacher Livonia Career Center 31-Aug-20	Clinical Nurse Beaumont Health System 5 years
Kummerl, Zada	Bachelor of Science Elementary Education & Math Grand Valley State University	(1.0) Elementary Teacher Cooper Upper Elementary August 31, 2020	Long-term Sub Cooper Upper Elementary 4th. Grade Teacher Jonesville, MI Substitute Teacher EDUStaff 3 months 4.5 months 1.5 years
Lovett, Sydney	Bachelor of Science Elementary Education Oakland University	(1.0) Elementary Teacher Riley Upper Elementary August 31, 2020	Nanny - Troy MI Student Teaching Long Meadow Elementary - Rochester MI Assistant Teacher KinderCare Learning Centers 3 months 8 months 2.5 years
Marshall, Brenna	Bachelor of Science Elementary Education & Language Arts Central Michigan University	(1.0) Elementary Teacher Coolidge Elementary 31-Aug-20	Substitute Teacher Livonia Public Schools Assistant Teacher IXL Learning Center - Hamburg MI 6 months 4 months
Mifsud, Lindsey	Bachelor of Science Early Childhood Education & Learning Central Michigan University	(1.0) Elementary Teacher Coolidge Elementary August 31, 2020	4th. Grade Teacher Cabrine Grade School Assistant Teacher New Morning School Assistant Teacher - Childtime Daycare 1 year 3 months 5 months

LIVONIA PUBLIC SCHOOLS
 Teachers for Board Approval
 September 28, 2020

Name	Degree/School	Assignment	Experience
Miller, Hannah	Bachelor of Arts Social Studies & History Eastern Michigan University	(1.0) Secondary Social Studies Holmes Middle School August 31, 2020	Substitute Teacher EDUStaff Long-term Sub Ypsilanti Community Schools 1.5 years 2 years
Misenar, Jillian	Bachelor of Science Elementary Education Eastern Michigan University	(1.0) Elementary Teacher Webster Elementary August 31, 2020	Upper Elementary Dean Metro Charter Academy - Romulus MI 5th. Grade Teacher, at-risk Reading Teacher & K-8 Behavior Specialist, Interim Dean Laurus Academy - Southfield MI Senior Practicum Coordinator Henry Ford Academy - Detroit 1 year 4 years 4 years
Mulville, Jill	Master of Arts Early Childhood Education Eastern Michigan University Bachelor of Science Elementary Education & Math Eastern Michigan University	(1.0) Early Childhood Program Jackson Early Childhood Center September 2, 2020	5th. Grade Math & Science Teacher Southfield Christian School 2nd. & 5th. Grade Teacher Oroville Christian School - Oroville CA 1 year 2 years
Nelson, Levi	Bachelor of Science Physical Education Grand Valley State University	(.43) Physical Education Teacher Shared Time September 2, 2020	Student Teaching West Ottawa High School Operations Supervisor Port Huron KOA Resort 4 months 1 year
O'Brien, Allison	Bachelor of Arts Elementary Education & Language Arts Michigan State University	(1.0) Elementary Teacher Coolidge Elementary 31-Aug-20	Coordinator/Instructor Day Camp 5 years
Olson, Amanda	Master of Arts Literacy Education & Reading Specialist Madonna University Bachelor of Arts Elementary Education & Spanish Albion College	(1.0) Elementary Teacher Grant Elementary August 31, 2020	Elementary Teacher Wayne-Westland Community Schools 8 years

LIVONIA PUBLIC SCHOOLS
 Teachers for Board Approval
 September 28, 2020

Name	Degree/School	Assignment	Experience
Osborne, Whitney	Master of Science Educational Leadership Madonna University Bachelor of Science Family & Consumer Science Madonna University	(1.0) Family & Consumer Science Stevenson High School September 2, 2020	Family & Consumer Science Teacher Brighton Area Schools Family & Consumer Science Teacher Saline Area Schools Family & Consumer Science Teacher Wayne-Westland Community Schools 1 year 3 years 3 years
Pilaftsidis, Maria	Bachelor of Arts Art Education - Painting & Sculpting Martin Malharro University - Argentina	(1.0) Art Teacher Franklin High School September 3, 2020	Visual Arts Instructor & department chair Washtenaw Internarion High School 10 years
Richardson, Lindsay	Bachelor of Science Elementary Education & Social Studies Wayne State University	(1.0) Elementary Teacher Cleveland Elementary August 31, 2020	Kindergarten Teacher Lincoln Park Public Schools Kindergarten Teacher Wyandotte Public Schools Long-term Substitute PESG 2 years 2 months 1 year
Ronayne, Kennedy	Bachelor of Arts Elementary Education & Language Arts Michigan State University	(1.0) Elementary Teacher Riley Upper Elementary August 31, 2020	Premier Substitute Teacher Northville Public Schools 1 year
Rosner, Stacy	Bachelor Arts English & Spanish Michigan State University	(1.0) Spanish Teacher Holmes Middle School September 3, 2020	Language Arts Teacher International Christian School of Lima Secondary Spanish Teacher Britton-Deerfield Schools Shared Time Spanish Teacher Livonia Public Schools 2 years 1 year 1 year
Salvia, Kathryn	Bachelor of Arts Fine Arts, Illustration College for Creative Studies	(1.0) Art Teacher Stevenson High School August 31, 2020	Teacher Assistant College for Creative Studies Teacher Aide A Growing Place Preschool & Childcare Center 1 year 5 years
Schroeder, Katelyn	Bachelor of Science Elementary Education & Math Eastern Michigan University	(1.0) Elementary Teacher Riley Upper Elementary August 31, 2020	Student Teacher Hamilton Elementary - Westland 4 months

LIVONIA PUBLIC SCHOOLS
Teachers for Board Approval
September 28, 2020

Name	Degree/School	Assignment	Experience	2 years
Smith, Kiley	Bachelor of Science Adolescent to Young Adult Education Integrated Social Studies/History Ohio University	(1.0) Secondary Social Studies (.5) Emerson Middle School (.5) Franklin High School September 3, 2020	High School Social Studies Teacher Avondale High School Educational Leader Detroit Historical Society	1 year
Smith, Mackenzie	Bachelor of Arts Elementary Education & Language Arts Michigan State University	(1.0) Elementary Teacher Hoover Elementary August 31, 2020	Cultural Ambassador & ESL Teacher Ministerio de Ed. - Madrid Spain Lead Counselor Harbor Point Association Substitute Walled Lake Schools	9 months
Spagnolo, Juliana	Bachelor of Science Elementary Education & Language Arts Oakland University	(1.0) Elementary Teacher Kennedy Elementary September 2, 2020	Long-term Substitute EDUStaff	5 months
Sparrow, Sarah	Bachelor of Science Elementary Education & Integrated Science Eastern Michigan University	(1.0) Elementary Teacher Buchanan Elementary August 31, 2020	Long-term Substitute EDUStaff	8 months
Straub, Ashley	Master of Education Curriculum & Instruction Concordia University Bachelor of Science Elementary Education & Early Childhood Education Eastern Michigan University	(1.0) Elementary Teacher Kennedy Elementary August 31, 2020	Kindergarten Teacher South Pointe Scholars Academy - Ypsilanti Long-term Substitute Smith Elementary School	8 years
Vanek, Kathryn	Bachelor of Science Elementary Education & Social Work University of Illinois, Urbana-Champaign	(1.0) Elementary Teacher Grant Elementary August 31, 2020	1st. Grade Dual English Teacher Schaumburg School - IL	1 year
Ware, Martha	Master of Arts Educational Leadership Wayne State University Bachelor of Science Career & Technical Education Western Michigan University	(1.0) Family & Consumer Science Stevenson High School September 2, 2020	Teacher Wayne-Westland Community Schools	21 years

LIVONIA PUBLIC SCHOOLS
 Teachers for Board Approval
 September 28, 2020

Name	Degree/School	Assignment	Experience
Warnick, Melissa	Master of Education Curriculum & Instruction American College of Education Bachelor of Arts Interdisciplinary Studies in Social Science Michigan State University	(1.0) Secondary Social Studies Churchill High School September 14, 2020	Social Studies Instructor Arts Academy in the Woods - Fraser 5 years
Widner, Lillian	Bachelor of Science Elementary Education & Early Childhood Education University of Toledo OH	(1.0) Elementary Teacher Coolidge Elementary August 31, 2020	Premier Substitute Plymouth-Canton Schools 6 months
Woodhall, Kaila	Bachelor of Science Elementary Education Eastern Michigan University	(1.0) Elementary Teacher Cooper Upper Elementary September 2, 2020	Teacher Monroe Public Schools Substitute Teacher EDUStaff 1 year 3 years
Wurster, Anna	Bachelor of Science Elementary Education & Language Arts Eastern Michigan University	(1.0) Elementary Teacher Kennedy Elementary August 31, 2020	Long-term Substitute EDUStaff 6 months
Yost, Haley	Bachelor of Science Elementary Education Central Michigan University	(1.0) Elementary Teacher Buchanan Elementary August 31, 2020	Substitute EDUStaff 1 year
Young, Paige	Master of Arts Teaching & Elementary Reading & Literacy Marygrove College Bachelor of Arts Elementary Education & Language Arts Grand Valley State University	(1.0) Elementary Teacher Webster Elementary August 31, 2020	Elementary Teacher South Lyon Community Schools 6 years

**LIVONIA PUBLIC SCHOOLS
BOARD OF EDUCATION MEETING
September 28, 2020**

TOPIC: Granting of Tenure Status to Specified Teachers

RECOMMENDATION:

Move that the Board of Education of the Livonia Public Schools School District accept the recommendation of the superintendent and acknowledge that tenure status has been granted to the following teachers, effective on the respective date:

<u>Name</u>	<u>Date</u>	<u>Name</u>	<u>Date</u>
Jeffrey Backus	August 31, 2020	Shelby Longworth	August 31, 2020
Lauren Bauer	August 28, 2020	Brittany Matties	August 31, 2020
Mark Bryden	August 28, 2020	Aaron Moran	September 6, 2020
Kay Campbell	August 7, 2020	Elizabeth Napier	August 31, 2020
Nicole Dennis	September 3, 2020	Stacie Oke	August 28, 2020
Joy Dunn	August 17, 2020	Steven Pascoe	August 31, 2020
Benjamin Edwards	September 24, 2020	Elizabeth Peers	September 4, 2020
Amanda Feheley	August 31, 2020	Alicia Robinson	August 31, 2020
Lindsey Freitag	August 31, 2020	Brian Rodgers	August 31, 2020
Ali Garrett	August 31, 2020	Lisa Salowich	August 28, 2020
Nicole Geverink	September 19, 2020	Laura Stevens	August 28, 2020
Melissa Haapala	August 31, 2020	Alex Tedesco	August 31, 2020
Miki Higa	August 7, 2020	Michelle Vanesley	August 28, 2020
Sarah Jacobsen	September 4, 2020	Andrew Wahl	August 31, 2020
Elizabeth Kilpatrick	August 31, 2020	Natalie Wahl	August 31, 2020
William Kramer	August 31, 2020		

RATIONALE :

These teachers have successfully completed the District's requirements for probationary teachers including years of service, evaluations, and overall performance, as well as student growth. We have carefully reviewed all of the supporting documents and based upon our review, as well as the recommendations of building principals, these individuals have achieved tenure status with the Livonia Public Schools.

RESOURCE PERSONNEL:

Keith McDonald, Director of Human Resources

EXHIBIT:

None

**LIVONIA PUBLIC SCHOOLS
BOARD OF EDUCATION MEETING
September 28, 2020**

TOPIC: Leaves of Absence

RECOMMENDATION:

Move that the Board of Education of the Livonia Public Schools School District accept the recommendation of the superintendent and approve the requests for a leave of absence as listed below:

<u>Name</u>	<u>Date effective</u>
Brenda Kleinow	FMLA to Child Care Leave 2020-21
Abigail Mencotti	FMLA to Child Care Leave 2020-21
Brittany Stall	Child Care Leave 2020-21
Laura Steele	FMLA to Child Care Leave 2020-21

BUDGETARY INFORMATION:

None

RESOURCE PERSONNEL:

Keith W. McDonald, Director of Human Resources

EXHIBIT:

None

ljn
Leave.cap

**LIVONIA PUBLIC SCHOOLS
BOARD OF EDUCATION MEETING
September 28, 2020**

TOPIC: Resignations

RECOMMENDATION:

As authorized in the Board of Education motion of June 15, 2020, resignations have been accepted by the superintendent for the persons listed below:

<u>Name</u>	<u>Date Effective</u>
Charlotte Collins (Shared Time)	August 27, 2020
Jessica Gibson (Shared Time)	August 21, 2020
Katherine Nihem	August 20, 2020
Missina Ormsby	September 4, 2020
Caitlin Schreuder (Great Start Readiness)	September 9, 2020
Nicholas Storey	August 31, 2020
Sheila Wofford-Glenn (Shared Time)	August 19, 2020

BUDGETARY INFORMATION:

None

RESOURCE PERSONNEL:

Keith W. McDonald, Director of Human Resources

EXHIBIT:

None

ljn
Resign-cap

**LIVONIA PUBLIC SCHOOLS
BOARD OF EDUCATION MEETING
September 28, 2020**

TOPIC: Resolutions of Appreciation for Employees Who Are Retiring

RECOMMENDATION:

Move that the Board of Education of the Livonia Public Schools School District adopt the attached resolutions of appreciation for the services rendered by:

**Katherine Barnes
Steven DiMarco
Lynne Feathers
Linda Gould
Anthony Grech
Cynthia Ignash
Fatino Kincaide
Mary Beth Klawender
Kevin Leja
Anthony Mazzella
Susan Sutton
Terese Wesley
Deborah Wutka
Julie Wyett**

BUDGETARY INFORMATION:

None

RESOURCE PERSONNEL:

Keith McDonald, Director of Human Resources

EXHIBIT:

Attached resolutions

**LIVONIA PUBLIC SCHOOLS
BOARD OF EDUCATION MEETING
September 28, 2020**

RESOLUTION

Katherine Barnes

WHEREAS, It has been brought to the attention of the Board of Education of the Livonia Public Schools School District that Katherine Barnes retired from the district on August 28, 2020; and,

WHEREAS, Katherine Barnes has devoted 24 years of dedicated, loyal, and outstanding service to the students of Cleveland Elementary, Rosedale Elementary, Cass Elementary and Webster Elementary as a teacher; and,

WHEREAS, She has made many contributions to the educational profession and has touched the lives of countless students during her tenure with the Livonia Public Schools;

NOW, THEREFORE, BE IT RESOLVED That the Board of Education does hereby congratulate Katherine Barnes on her years of service to the educational profession and expresses publicly its sincere appreciation and offers its best wishes for her retirement.

Steven DiMarco

WHEREAS, It has been brought to the attention of the Board of Education of the Livonia Public Schools School District that Steven DiMarco retired from the district on June 20, 2020; and,

WHEREAS, Steven DiMarco has devoted 20 years of dedicated, loyal, and outstanding service to the students of Franklin High School, Holmes Middle School, Churchill High School and Cooper Upper Elementary as a teacher; and,

WHEREAS, He has made many contributions to the educational profession and has touched the lives of countless students during his tenure with the Livonia Public Schools;

NOW, THEREFORE, BE IT RESOLVED That the Board of Education does hereby congratulate Steven DiMarco on his years of service to the educational profession and expresses publicly its sincere appreciation and offers its best wishes for his retirement.

Lynne Feathers

WHEREAS, It has been brought to the attention of the Board of Education of the Livonia Public Schools School District that Lynne Feathers retired from the district on June 12, 2020; and,

WHEREAS, Lynne Feathers has devoted 14 years of dedicated, loyal, and outstanding service to the Livonia Public Schools as a special education paraprofessional at Cleveland Elementary, Riley Upper Elementary, Johnson Upper Elementary and Webster Elementary; and,

WHEREAS, She has given conscientious, careful, and loyal service to the students, staff, and community during her tenure with the Livonia Public Schools;

NOW, THEREFORE, BE IT RESOLVED That the Board of Education does hereby express its deep appreciation to Lynne Feathers for her countless contributions to our school system and extends best wishes for an enjoyable and rewarding retirement.

Linda Gould

WHEREAS, It has been brought to the attention of the Board of Education of the Livonia Public Schools School District that Linda Gould retired from the district on August 26, 2020; and,

WHEREAS, Linda Gould has devoted 13.3 years of dedicated, loyal, and outstanding service to the Livonia Public Schools as a bus driver in the transportation department; and,

WHEREAS, She has given conscientious, careful, and loyal service to the students, staff, and community during her tenure with the Livonia Public Schools;

NOW, THEREFORE, BE IT RESOLVED That the Board of Education does hereby express its deep appreciation to Linda Gould for her countless contributions to our school system and extends best wishes for an enjoyable and rewarding retirement.

Anthony Grech

WHEREAS, It has been brought to the attention of the Board of Education of the Livonia Public Schools School District that Anthony Grech retired from the district on August 31, 2020; and,

WHEREAS, Anthony Grech has devoted 21 years of dedicated, loyal, and outstanding service to the Livonia Public Schools as a paraprofessional at Dickinson Center and bus driver in the transportation department; and,

WHEREAS, He has given conscientious, careful, and loyal service to the students, staff, and community during his tenure with the Livonia Public Schools;

NOW, THEREFORE, BE IT RESOLVED That the Board of Education does hereby express its deep appreciation to Anthony Grech for his countless contributions to our school system and extends best wishes for an enjoyable and rewarding retirement.

Cynthia Ignash

WHEREAS, It has been brought to the attention of the Board of Education of the Livonia Public Schools School District that Cynthia Ignash retired from the district on June 30, 2020; and,

WHEREAS, Cynthia Ignash has devoted 25 years of dedicated, loyal, and outstanding service to the Livonia Public Schools as a paraprofessional at McKinley Elementary, Coolidge Elementary, Marshall Elementary, Roosevelt Elementary, Washington Elementary, Hull Elementary, Cass Elementary, Perrinville Early Childhood Center and Randolph Elementary; and,

WHEREAS, She has given conscientious, careful, and loyal service to the students, staff, and community during her tenure with the Livonia Public Schools;

NOW, THEREFORE, BE IT RESOLVED That the Board of Education does hereby express its deep appreciation to Cynthia Ignash for her countless contributions to our school system and extends best wishes for an enjoyable and rewarding retirement.

Fatino Kincaide

WHEREAS, It has been brought to the attention of the Board of Education of the Livonia Public Schools School District that Fatino Kincaide will retire from the district on October 30, 2020; and,

WHEREAS, Fatino Kincaide has devoted 33.5 years of dedicated, loyal, and outstanding service to the students of Cleveland Elementary, Coolidge Elementary, McKinley Elementary, Taylor Elementary, Johnson Elementary, Cass Elementary, Hayes Elementary, Kennedy Elementary and Cooper Upper Elementary as a teacher; and,

WHEREAS, She has made many contributions to the educational profession and has touched the lives of countless students during her tenure with the Livonia Public Schools;

NOW, THEREFORE, BE IT RESOLVED That the Board of Education does hereby congratulate Fatino Kincaide on her years of service to the educational profession and expresses publicly its sincere appreciation and offers its best wishes for her retirement.

Mary E. Klawender

WHEREAS, It has been brought to the attention of the Board of Education of the Livonia Public Schools School District that Mary E. Klawender retired from the district on June 30, 2020; and,

WHEREAS, Mary E. Klawender has devoted 25.3 years of dedicated, loyal, and outstanding service to the students of Franklin High School as a teacher; and,

WHEREAS, She has made many contributions to the educational profession and has touched the lives of countless students during her tenure with the Livonia Public Schools;

NOW, THEREFORE, BE IT RESOLVED That the Board of Education does hereby congratulate Mary E. Klawender on her years of service to the educational profession and expresses publicly its sincere appreciation and offers its best wishes for her retirement.

Kevin Leja

WHEREAS, It has been brought to the attention of the Board of Education of the Livonia Public Schools School District that Kevin Leja retired from the district on August 31, 2020; and,

WHEREAS, Kevin Leja had devoted 31.4 years of dedicated, loyal, and outstanding service to the Livonia Public Schools as a custodian at Churchill High School, Stevenson High School and Kennedy Elementary; and,

WHEREAS, He has given conscientious, careful, and loyal service to the students, staff, and community during his tenure with the Livonia Public Schools;

NOW, THEREFORE, BE IT RESOLVED That the Board of Education does hereby express its deep appreciation to Kevin Leja for his countless contributions to our school system and extends best wishes for an enjoyable and rewarding retirement.

Anthony Mazzella

WHEREAS, It has been brought to the attention of the Board of Education of the Livonia Public Schools School District that Anthony Mazzella retired from the district on August 31, 2020; and,

WHEREAS, Anthony Mazzella has devoted 34 years of dedicated, loyal, and outstanding service to the Livonia Public Schools as a custodian and building supervisor at Adams Elementary, Garfield Elementary, Hayes Elementary, Stevenson High School, Franklin High School and Hoover Elementary; and,

WHEREAS, He has given conscientious, careful, and loyal service to the students, staff, and community during his tenure with the Livonia Public Schools;

NOW, THEREFORE, BE IT RESOLVED That the Board of Education does hereby express its deep appreciation to Anthony Mazzella for his countless contributions to our school system and extends best wishes for an enjoyable and rewarding retirement.

Susan Sutton

WHEREAS, It has been brought to the attention of the Board of Education of the Livonia Public Schools School District that Susan Sutton retired from the district on July 3, 2020; and,

WHEREAS, Susan Sutton has devoted 26 years of dedicated, loyal, and outstanding service to the students of Tyler Elementary and Grant Elementary as a teacher; and,

WHEREAS, She has made many contributions to the educational profession and has touched the lives of countless students during her tenure with the Livonia Public Schools;

NOW, THEREFORE, BE IT RESOLVED That the Board of Education does hereby congratulate Susan Sutton on her years of service to the educational profession and expresses publicly its sincere appreciation and offers its best wishes for her retirement.

Terese Wesley

WHEREAS, It has been brought to the attention of the Board of Education of the Livonia Public Schools School District that Terese Wesley retired from the district on August 28, 2020; and,

WHEREAS, Terese Wesley has devoted 17.1 years of dedicated, loyal, and outstanding service to the students of McKinley Elementary, Coolidge Elementary, Riley Elementary, Coolidge Elementary, Buchanan Elementary and Grant Elementary as a special education paraprofessional and teacher; and,

WHEREAS, She has made many contributions to the educational profession and has touched the lives of countless students during her tenure with the Livonia Public Schools;

NOW, THEREFORE, BE IT RESOLVED That the Board of Education does hereby congratulate Terese Wesley on her years of service to the educational profession and expresses publicly its sincere appreciation and offers its best wishes for her retirement.

Deborah Wutka

WHEREAS, It has been brought to the attention of the Board of Education of the Livonia Public Schools School District that Deborah Wutka retired from the district on June 15, 2020; and,

WHEREAS, Deborah Wutka has devoted 27.5 years of dedicated, loyal, and outstanding service to students throughout the district as a school psychologist; and,

WHEREAS, She has made many contributions to the educational profession and has touched the lives of countless students during her tenure with the Livonia Public Schools;

NOW, THEREFORE, BE IT RESOLVED That the Board of Education does hereby congratulate Deborah Wutka on her years of service to the educational profession and expresses publicly its sincere appreciation and offers its best wishes for her retirement.

Julie Wyett

WHEREAS, It has been brought to the attention of the Board of Education of the Livonia Public Schools School District that Julie Wyett retired from the district on June 20, 2020; and,

WHEREAS, Julie Wyett has devoted 29 years of dedicated, loyal, and outstanding service to the students of Cleveland Elementary as a literacy coach and teacher; and,

WHEREAS, She has made many contributions to the educational profession and has touched the lives of countless students during her tenure with the Livonia Public Schools;

NOW, THEREFORE, BE IT RESOLVED That the Board of Education does hereby congratulate Julie Wyett on her years of service to the educational profession and expresses publicly its sincere appreciation and offers its best wishes for her retirement.