



Ford Administration
1620 E. Elza, Hazel Park, MI 48030 | 248-658-5200 | F: 248-544-5223
www.hazelparkschools.org

Agenda

Regular Meeting

Ford Administration Building

1620 E Elza Avenue

Hazel Park, MI 48030

November 18, 2024

5:30 PM

LOCATION AND FORMAT: The meeting will be held at the Ford Administration Building, 1620 E Elza Hazel Park, Michigan. It will be live-streamed on YouTube. Members of the public wishing to speak during the public comment portion of the meeting may do so in-person or by emailing Board President, Rick Nagy, prior to the meeting at rick.nagy@myhpsd.org.

CALL TO ORDER

ROLL CALL

PLEDGE OF ALLEGIANCE

APPROVAL OF THE AGENDA (ACTION ITEM)

SPECIAL ORDER OF BUSINESS

- A. Student of the Month
- B. Junior High Representative
- C. High School Representative
- D. Advantage Representative

PUBLIC COMMENT

The Board of Education recognizes the value of public comment on education items and the importance of allowing members of the public to express themselves on District matters.

During this portion of public comment, each statement made by a participant shall be limited to three (3) minutes and participants must identify themselves by name and address.

CONSENT AGENDA (Action Items)

The Board of Education shall use a consent agenda to keep routine matters within a reasonable time frame. A member of the Board may request any item to be removed from the consent agenda and defer it for more discussion and specific action.

A. Approval of Minutes

1) Board Meetings

- a. 11.4.24 Special Board Of Education Meeting Unofficial Minutes

1. *11.4.24 Board Of Education Special Meeting Closed Session Minutes	
2) Committee Meetings	
a. 11.11.24 Board Of Education Committee of the Whole Unofficial Minutes	11
1. *11.11.24 Board Of Education Committee of the Whole Closed Session Minutes	
B. <u>Monthly Financial Reports</u>	<u>15</u>
C. <u>Personnel Recommendations</u>	<u>31</u>
D. <u>Conference Requests (Under \$500)</u>	<u>32</u>
E. <u>Superintendent Conference</u>	<u>33</u>
NEW BUSINESS	
A. Longfellow RFP (Action Item)	35
B. Freedom Of Information Act (FOIA) (Informational Item)	196
C. Door Change Request (Action Item)	197
D. Basketball Backstop (Action Item)	208
E. Facility Usage Agreement (Action Item)	213
F. Junior High Washington DC Trip (Action Item)	222
G. Business Consultant (Action Item)	242
H. Additional Part-Time Security Guards (Action Item)	243
I. Board Member Conference Reimbursement (Action Item)	244
J. January Board Meeting Times (Action Item)	249
CLOSED SESSION	
A. Motion to recess into closed session under Section 8(f) of the Open Meetings Act to review and consider the contents of an application for employment. In compliance with this act, all candidate interviews will be held in an open meeting unless otherwise specified by law.	
SUPERINTENDENT REPORT	
A. Enrollment	250
B. Fundraisers	251
C. ADK Grant Winner	252
REQUESTS FOR FUTURE AGENDA ITEMS	
CALENDAR DATES	
A. Monday, December 2, 2024 - Board of Education Workshop - 5:00pm	
B. Monday, December 9, 2024 - Board of Education Committee of the Whole - 3:00pm	
C. Monday, December 16, 2024 - Board of Education Regular Meeting - 5:30pm	
PUBLIC COMMENT	
<i>During this portion of public comment, each statement made by a participant shall be limited to one (1) minute and participants must identify themselves by name and address.</i>	
BOARD MEMBER AND ADMINISTRATION COMMENTS	

ADJOURNMENT

Any person with a disability who needs accommodation for participation in this meeting should contact the Superintendent's office at (248) 658-5220 at least five (5) days in advance of the meeting to request assistance.

All Official minutes of school board meetings are stored and available for inspection in the Ford Administration office at the above address.

This notice is given in compliance with Act No. 267 of the Public Acts Michigan, 1976



**SCHOOL DISTRICT OF THE
CITY OF HAZEL PARK
COUNTY OF OAKLAND AND STATE OF MICHIGAN
SPECIAL MEETING**

CALL TO ORDER

The Special Meeting of the Hazel Park Board of Education was held at the Ford Administration on November 4, 2024 and was called to order by President Nagy at 5:00 PM. President Nagy asked for a moment of silence for Mr. Frank Stagg, a former teacher in Hazel Park and Mr. Ken Scott, a former staff member's husband and lifelong Hazel Park resident.

ROLL CALL

Members Present: Beaton, Fortress, Hinton, Laframboise, Rattee, Nagy
Members Absent: Baldwin
Others Present: Dulmage, Cales, Papasian-Broadwell

PLEDGE OF ALLEGIANCE

APPROVAL OF THE AGENDA (Action Item)

Moved by Fortress, supported by Rattee, that the Board of Education approve the Agenda, as written.

Discussion

Roll Call Vote

Yeas: Fortress, Rattee, Beaton, Hinton, Laframboise, Nagy
Nays:

Motion carried.

SPECIAL ORDER OF BUSINESS

- A. Student of the Month
- B. New Staff Introductions
- C. Junior High Representative
- D. High School Representative
- E. Advantage Representative
- F. Promise Zone Presentation

PUBLIC COMMENT

- | | |
|----------------------|---|
| 1. Janice Howard | Mrs. Howard shared concerns for Hazel Park Junior Vikings. |
| 2. Andrew Kremhelmer | Mr. Kremhelmer shared his opinion on a time for change, adding a reminder that election day is tomorrow. Encouraging the community to get out and vote. |
| 3. Kim Allen | Ms. Allen shared concerns for Hazel Park Junior Vikings. |
| 4. Sasha Salzman | Ms. Salzman shared a special recognition for Mrs. Monterosso at United Oaks along with other staff members. Would like more parent involvement for special education parents. |

CONSENT AGENDA (Action Items)

- A. Approval of Minutes
 - 1) Board Meetings
 - a. September 16, 2024 - Regular Meeting
 - b. September 24, 2024 - Special Meeting
 - 2) Committee Meetings
 - a. October 14, 2024 - Committee of the Whole
- B. Monthly Financial Reports
- C. Personnel Recommendations
- D. Conference Requests (under \$500)

Moved by Fortress, supported by Rattee, that the Board of Education approve the consent agenda, as written.

Discussion

Roll Call Vote

Yeas: Fortress, Rattee, Beaton, Hinton, Laframboise, Nagy

Nays:

Motion carried.

NEW BUSINESS

- A. National Principals Month (Action Item)

Moved by Fortress, supported by Rattee, that the Board of Education approve the resolution for National Principals Month, as presented.

Discussion

Roll Call Vote

Yeas: Fortress, Rattee, Beaton, Hinton, Laframboise, Nagy

Nays:

Motion carried.

- B. PowerSchool (Action Item)

Moved by Fortress, supported by Rattee, that the Board of Education approve the purchase of PowerSchool professional services, as presented.

Discussion

Roll Call Vote

Yeas: Fortress, Rattee, Beaton, Hinton, Laframboise, Nagy

Nays:

Motion carried.

- C. Quaver Music (Action Item)

Moved by Fortress, supported by Rattee, that the Board of Education approve the purchase of a Quaver Music in an amount not to exceed \$6,300.

Discussion

Roll Call Vote

Yeas: Fortress, Rattee, Beaton, Hinton, Laframboise, Nagy

Nays:

Motion carried.

D. ELLevation Multilingual Program Management Platform (Action Item)

Moved by Fortress, supported by Rattee, that the Board of Education approve the purchase of the ELLevation in an amount not to exceed \$23,000.

Discussion

Roll Call Vote

Yeas: Fortress, Rattee, Beaton, Hinton, Laframboise, Nagy

Nays:

Motion carried.

E. High School - 2024 Thespian Festival (Action Item)

Moved by Fortress, supported by Rattee, that the Board of Education approve funding for the Hazel Park delegation to attend the Thespian Festival for the 2024-2025 school year.

Discussion

Roll Call Vote

Yeas: Fortress, Rattee, Beaton, Hinton, Laframboise, Nagy

Nays:

Motion carried.

F. High School NYC Trip (Action Item)

Moved by Fortress, supported by Rattee, that the Board of Education approve the trip to NYC for the High School Drama Honor Society, as presented.

Discussion

Roll Call Vote

Yeas: Fortress, Rattee, Beaton, Hinton, Laframboise, Nagy

Nays:

Motion carried.

G. 1.0 FTE Speech/Language Pathologist (Action Item)

Moved by Fortress, supported by Rattee, that the Board of Education approve the hiring of a 1.0 FTE Speech and Language Pathologist.

Discussion

Roll Call Vote

Yeas: Fortress, Rattee, Beaton, Hinton, Laframboise, Nagy

Nays:

Motion carried.

H. Webster Additional Paraprofessionals (Action Item)

Moved by Fortress, supported by Rattee, that the Board of Education approve the hiring of two 1:1 Paraprofessionals for Webster Early Childhood Center's Braided PreSchool.

Discussion

Roll Call Vote

Yeas: Fortress, Rattee, Beaton, Hinton, Laframboise, Nagy

Nays:

Motion carried.

I. Additional Part-Time Evening Security Personnel (Action Item)

Moved by Fortress, supported by Rattee, that the Board of Education approve the hiring of two additional part time security guards for HPHS & HPJH, as presented.

Amended motion: Moved by Fortress, supported by Rattee to remove motion and table the Additional Part-Time Evening Security Personnel and bring to Committee of the Whole for November.

Discussion

Roll Call Vote

Yeas: Fortress, Rattee, Beaton, Hinton, Laframboise, Nagy

Nays:

Motion carried.

J. Special Education Testing Materials (Action Item)

Moved by Fortress, supported by Rattee, that the Board of Education approve the purchase of materials and training to implement Q-Interactive Web Based Evaluation Tools at a cost not to exceed \$14,000.

Discussion

Roll Call Vote

Yeas: Fortress, Rattee, Beaton, Hinton, Laframboise, Nagy

Nays:

Motion carried.

K. Transportation Garage Gate (Action Item)

Moved by Fortress, supported by Rattee, that the Board of Education approve the replacement of the existing gate not to exceed \$7,520.00.

Discussion

Roll Call Vote

Yeas: Fortress, Rattee, Beaton, Hinton, Laframboise, Nagy

Nays:

Motion carried.

L. Edison Compressor Replacement (Action Item)

Moved by Fortress, supported by Rattee, that the Board of Education approve the compressor replacement for the freezer to ensure continued safe operation at Edison at a cost not to exceed \$9000.

Discussion

Roll Call Vote

Yeas: Fortress, Rattee, Beaton, Hinton, Laframboise, Nagy

Nays:

Motion carried.

M. Business Manager Salary (Action Item)

Moved by Fortress, supported by Rattee, that the Board of Education approve the increase in salary for Crystal Mubarak, as presented.

Amended motion: Moved by Fortress, supported by Rattee to remove motion and table the Business Manager Salary until the Audit has been completed.

Discussion

Roll Call Vote

Yeas: Fortress, Rattee, Beaton, Hinton, Laframboise, Nagy

Nays:

Motion carried.

N. MVCA Contract Amendment for Adjustment of Grade/Band Cap (Action Item)

Moved by Fortress, supported by Rattee, that the Board of Education approve the Contract Amendment for MVCA, as presented.

Discussion

Roll Call Vote

Yeas: Fortress, Rattee, Beaton, Hinton, Laframboise, Nagy

Nays:

Motion carried.

O. Conference Requests (Over \$500) (Action Item)

Moved by Fortress, supported by Rattee, that the Board of Education approve the conference requests for over \$500, as presented.

Discussion

Roll Call Vote

Yeas: Fortress, Rattee, Beaton, Hinton, Laframboise, Nagy

Nays:

Motion carried.

P. 2024 State Aid Note (Action Item)

Moved by Fortress, supported by Rattee, that the Board of Education approve the 2024 State Aid Note Resolution, as presented.

Discussion

Roll Call Vote

Yeas: Fortress, Rattee, Beaton, Hinton, Laframboise, Nagy

Nays:

Motion carried.

Q. Student Discipline (Action Item)

Moved by Fortress, supported by Rattee, that the Board of Education approve the Student Discipline, as presented.

Discussion

Roll Call Vote

Yeas: Fortress, Rattee, Beaton, Hinton, Laframboise, Nagy

Nays:

Motion carried.

CLOSED SESSION

- A. Motion to recess into closed session (a) to consider the dismissal, suspension, or disciplining of, or to hear complaints or charges brought against or to consider a periodic personnel evaluation of a public officer, employee, staff members, or individual agent, if the individual requests a closed hearing. An individual requesting a closed hearing may rescind the request at any time, in which case the matter at issue shall be considered after the rescission only in open sessions; which is exempt from disclosure pursuant to Section 8(a) of the Open Meeting Act.

Moved by Fortress, supported by Rattee, that the Board of Education move in to closed session for the purpose of 8(a)

Discussion

Roll Call Vote

Yeas: Fortress, Rattee, Beaton, Hinton, Laframboise, Nagy

Nays:

Motion carried.

Moved to closed session at 6:42pm

Meeting returned to open session at 7:46pm

Moved by Fortress, supported by Rattee, that the Board of Education return to open session.

Discussion

Roll Call Vote

Yeas: Fortress, Rattee, Beaton, Hinton, Laframboise, Nagy

Nays:

Motion carried.

SUPERINTENDENT REPORT

- A. ADK Grant Winners
- B. Fundraisers
- C. Enrollment

REQUESTS FOR FUTURE AGENDA ITEMS

CALENDAR DATES

- A. *November 11, 2024 Committee of the Whole 3:00pm*
- B. *November 18, 2024 Board of Education Regular Meeting 5:30pm*
- C. *November 19, 2024 Portrait of a Learner 5:00pm*

PUBLIC COMMENT

- 1. Janice Howard Mrs. Howard shared concerns over letter received for husband.
- 2. Kim Allen Ms. Allen shared opinion in support of Mr. Howard.

BOARD MEMBER AND ADMINISTRATION COMMENTS

Deborah Laframboise, Trustee

The football game will be against Armada at 7:00pm. The play for our drama students will be December 5th, 6th and 7th at the Junior High. And go vote!

Heidi Fortress, Trustee

Last weekend Debbie, Bev and I attended a conference in Lansing. It was fantastic! I learned a lot and I bought the speakers books and also won a painting. There was a lot of great information was shared. It was very long but it was also a lot of fun and very educational. Thank you Board for allowing me to attend. Congrats to the football team! I hope the city and the school can come together and keep the program strong. I'm looking forward to the unveiling of the muriel at the Library.

Beverly Hinton, Trustee

The conference was an awesome experience! Lots of reminders that there is a board of 7 for a reason. How to run an effective meeting, goals and missions, the purpose and how to use them effectively. Sam Glen was great, kicking the attitude, he talked about getting past the attitude and not holding people accountable for their opinions. Dr Brown was another keynote speaker at the conference, he spoke about reflecting on yourself. Thank you Board for allowing me to attend. It was also said that rules don't govern behavior. Thank you Karla for the pumpkins and the Farmer's Market. You did a great job pulling that together. The principals thank you again as you set the tone for your buildings.

Monica Rattee, Treasurer

I think everything has already been said but I'm looking forward to the sports.

April Beaton, Trustee

Congratulations to the football team. We're at a monumental time in the school, it's the end of the 1st card marking. It's not just monumental for students but also for the staff. I'm so proud of all of you.

Amy Kruppe, Superintendent

(No comments to share at this time)

Rick Nagy, President

Thank you for being here and I forgot to mention we had another great loss to our community as Father Bob has passed away. He was not only a member of the church but he was an Auxiliary Police Officer. This is such a great loss to Hazel Park.

Adjournment

Moved and supported that the meeting be adjourned at 7:55pm.

Unanimous Approval.



SCHOOL DISTRICT OF THE
CITY OF HAZEL PARK
COUNTY OF OAKLAND AND STATE OF MI
COMMITTEE OF THE WHOLE MEETING
November 11, 2024 3:00 PM

CALL TO ORDER

The Committee of the Whole Meeting of the Hazel Park Board of Education was held on November 11, 2024 and was called to order by President Nagy at 3:00 p.m.

ROLL CALL

Members Present: Beaton, Fortress, Hinton, Laframboise, Rattee, Nagy
Members Absent: Baldwin
Others Present: Kruppe, Dulmage, Cales

APPROVAL OF THE AGENDA (ACTION ITEM)

Moved by Fortress, supported by Rattee, that the Board of Education approve the agenda as written.

Discussion

Roll Call Vote

Yeas: Fortress, Rattee, Beaton, Hinton, Laframboise, Nagy
Nays:

Motion carried.

PUBLIC COMMENT - None

NEW BUSINESS

A. BUILDINGS & GROUNDS

1) Longfellow RFP

Discussion: Mr. John Davids, Architect of Record, reported that two bids were received for the Longfellow project. After reviewing both, King Scott recommends Spartan Construction, whose bid came in under budget and who has a successful track record with the district. The project is expected to be completed by June 2025. This will be taken to the November regular meeting for a vote.

2) Jardon Swing

Discussion: Dr. Kruppe provided an update on the Jardon swing purchased last year, noting that it can be installed in the courtyard. Mr. Davids will create landscape sketches, and the courtyard's catch basin will require repairs.

3) Basketball Backstop

Discussion: Dr. Kruppe presented a quote for two new basketball backstops for the high school, including installation. Electrical work will be handled in-house by district electricians. The board inquired if the quoting company would also provide ongoing service for the backstops, with an answer to be provided when this is taken to the November regular meeting for a vote.

B. PERSONNEL

1) Facility Usage Agreement

Discussion: Dr. Kruppe presented the Facility Usage Agreement, and the board discussed implementing mandatory security for all events. Additionally, groups in categories 3 and 4 will be charged a usage fee under the updated agreement. This will be taken to the November regular meeting for a vote.

2) Basketball Coach

Discussion: Dr. Kruppe shared a hiring request for a coach with a felony on their record. The Board requested further information at the regular meeting, with a closed session scheduled for discussion.

C. POLICY

1) Financial Oversight

Discussion: This will be brought back to the December Committee of the Whole.

D. FINANCE

1) Audit/Personnel Update

Discussion: Dr. Kruppe provided an update on the audit and personnel changes following the departure of the Assistant Superintendent of Business and Operations. Some journal entries remain pending, and with auditors closed for Veteran's Day, no completion date for the audit is currently available.

2) Check Register & CC Statement

Discussion: All items were reviewed, with some questions pending answers to be addressed at the November regular meeting.

E. OTHER

1) LEO

Discussion: Dr. Dulmage reported that elementary instructional coaches are now networking statewide, sharing best practices to improve teaching strategies. Expanded Tier 2 and Tier 3 supports are benefiting students across the county. Coaches are also receiving grant-funded training, enhancing instructional quality throughout our district.

2) Grants

- a) Oakland Schools - EPIC Program
- b) 2023 Stronger Connections Funding Cohort 2
- c) DFC - Year 2
- d) 35j Professional Development, Curriculum and Supports Grant
- e) 23H - Improvement for Math

Discussion: All grant information will be placed in the Board's shared folder in the Drive. Oakland schools - Epic Program is for middle school training. 2023 Stronger Connections Funding Cohort 2 is used to offset the cost of restorative practice training. The DFC Year 2 grant is financial oversight for the Hazel Park Community Coalition. And, the 35j has been written to offset the American Reading Company (ARC) training. Lastly, the 23H is also an ISD grant with multiple consortiums for Math improvement.

3) Future Board Meetings

Discussion: The board discussed waiting until the January meeting to complete the list of meeting dates and times when the new board has joined.

4) January Board Meeting Times

Discussion: It was discussed that the time should remain the same for January with the exception of Committee of the Whole because one of the new board members cannot attend until after 4:15pm.

5) Board Member Training

- a) First-Time Trustee Orientation Dinner - December 18th, 2024 @ 6:00pm (Oakland Schools)

Discussion: The January 6th workshop will be CBA 101 to help the new board members to understand the basics of their new responsibilities.

F. CLOSED SESSION

- 1) Motion to recess into closed session (e) to consult with its attorney regarding connection of specific pending litigation, but only if an open meeting would have a detrimental financial effect on litigating or settlement position of the public body pursuant to Section 8(e) of the Open Meetings Act.

Moved by Laframboise, supported by Hinton, that the Board of Education approve recessing into closed session (e) to consult with its attorney regarding connection of specific pending litigation pursuant to Section 8(e) of the Open Meetings Act.

Discussion

Roll Call Vote

Yeas: Laframboise, Hinton, Beaton, Fortress, Rattee, Nagy
Nays:

Motion carried.

Moved to Closed Session 5:00pm.

Moved by Rattee, supported by Beaton, that the Board of Education return to open session.

Discussion

Roll Call Vote

Yeas: Rattee, Beaton, Fortress, Hinton, Laframboise, Nagy

Nays:

Motion carried.

REQUEST FOR FUTURE AGENDA ITEMS

PUBLIC COMMENT - None

BOARD MEMBER AND ADMINISTRATION COMMENTS

Deborah Laframboise, Trustee (No comments to share)

Heidi Fortress, Trustee (No comments to share)

Beverly Hinton, Trustee I would like to give a shout out to our Veterans! Thank you for all that you do, for all the freedoms you have given us.

Monica Rattee, Treasurer (No comments to share)

April Beaton, Trustee (No comments to share)

Dr. Kruppe, Superintendent (No comments to share)

Rick Nagy, President (No comments to share)

Moved and supported that the meeting be adjourned by 5:22 pm.

Unanimous approval.



Hazel Park School District

ALL IN ALL THE TIME

Amy Kruppe, Ed.D.
Superintendent

Ford Administration

1620 E. Elza, Hazel Park, MI 48030 • Phone 248-658-5200 | Fax 248-544-5443

TO: The School District of the City of Hazel Park
Board of Education

FROM: Crystal Mubarak
Director of Business

RE: Treasurer's Report October, 2024

DATE: November 4, 2024

Attached is the check register (including current period voids), a listing of ACH debits, wire transfers, and P-Card purchases made during the period

GENERAL FUND (11)		1,155,808.87	
	<i>Total - General Fund</i>	<u>\$ 1,155,808.87</u>	
CENTER PROGRAM (22)		17,562.06	
COMMUNITY SERVICE (23)		639.71	
FOOD SERVICE FUND (25)		287,350.19	
COMMON DEBT (31-39)		0.00	
CAPITAL PROJECTS (41-49)		12,225.81	
	<i>Total - Special Revenue Funds</i>	<u>\$ 317,777.77</u>	
TRUST FUNDS (51)		0.00	
INTERNAL ACCOUNT FUNDS (29)		12,186.86	
	<i>Total - Other Funds</i>	<u>\$ 12,186.86</u>	
TOTAL CHECK DISBURSEMENTS		<u><u>\$ 1,485,773.50</u></u>	\$ 1,485,773.50
ACH DEBITS			2,289,351.78
PAYROLL			1,766,170.57
OUTGOING WIRE TRANSFERS			2,814,951.69
P-CARD PURCHASES			<u>101,928.37</u>
			6,972,402.41
TOTAL DISBURSEMENTS IN PERIOD			<u><u>\$ 8,458,175.91</u></u>

I certify that the disbursements listed on the attached check registers and listing of ACH debits, wire transfers, and P-Card purchases were payments made for obligations of The School District of the City of Hazel Park and that all materials or services listed on the invoices have been received or performed.

Crystal Mubarak
Director of Business

Monthly Summary of EFT's from HP Bank Accounts

Sep-22

<u>Date</u>	<u>Amount</u>	<u>Bank Acct Taken From</u>	<u>Reason</u>
10/2/2024	\$302.59	Gen Funds	Latchkey Fees
10/7/2024	\$6,096.69	Gen Funds	Health Equity Payment October 4th Payroll
10/23/2024	\$5,673.78	Gen Funds	Health Equity Payment October 18th Payroll
10/3/2024	\$12,569.75	Gen Funds	EduStaff Payment
10/17/2024	\$19,329.47	Gen Funds	EduStaff Payment
10/31/2024	\$17,476.79	Gen Funds	EduStaff Payment
10/8/2024	\$23,271.74	Gen Funds	Penserv Payment October 4th Payroll
10/24/2024	\$22,655.42	Gen Funds	Penserv Payment October 18th Payroll
10/4/2024	\$48,216.68	Tax W/H	Payroll State Tax Withholding October 4th
10/23/2024	\$41,555.19	Tax W/H	Payroll State Tax Withholding October 18th
10/4/2024	\$336,470.92	Tax W/H	Payroll Federal Tax Withholding October 4th
10/22/2024	\$281,921.09	Tax W/H	Payroll Federal Tax Withholding October 18th
10/7/2024	\$427,624.23	Ret W/H	Payroll Retirement Withholding September 20th
10/17/2024	\$531,853.01	Ret W/H	Payroll Retirement Withholding October 4th
10/30/2024	\$514,334.43	MESSA	MESSA Payments

\$2,289,351.78 Total ACH Debits

<u>Date</u>	<u>Amount</u>	<u>Payroll</u>
10/4/2024	\$908,673.53	General Payroll on October 4th
10/18/2024	\$857,497.04	General Payroll on October 18th

\$1,766,170.57 Total Payroll

<u>Date</u>	<u>Amount</u>	<u>Wires</u>
10/28/2024	\$2,814,951.69	MVCA Wire State Aid

\$2,814,951.69 Total Wires

<u>Date</u>	<u>Amount</u>	<u>P-Card Purchases</u>
10/22/2024	\$101,928.37	General P-Card charges Huntington Bank

\$101,928.37 Total P-Card Purchases

Hazel Park Schools
Budget to Actual by St Revenue and St Function
As of 10/31/2024

St Revenue/Function	Description	Original Budget	Encumbrance	Actual	Balance	Percent
Type: 4 Revenue						
St Revenue: 100	Revenue from Local Sources	6,310,500.00	0.00	3,720,688.71	1,983,825.29	58.96%
St Revenue: 300	Rev from State Sources	43,062,068.00	0.00	0.00	28,907,259.00	0.00%
St Revenue: 400	Rev from Federal Sources	1,862,829.00	0.00	0.00	7,553,087.00	0.00%
St Revenue: 500	Incoming Transfer/Oth Transact	2,940,000.00	0.00	0.00	2,430,209.40	0.00%
St Revenue: 600	Fund Modifications	1,687,000.00	0.00	0.00	1,619,040.36	0.00%
	Revenue Total:	55,862,397.00	0.00	3,720,688.71	42,493,421.05	6.66%
Type: 5 Expense						
St. Function:110	Basic Programs	21,884,914.00	287,502.80	6,127,382.31	15,757,531.69	28.00%
St. Function:120	Added Needs	11,112,868.00	7,410.46	2,900,712.87	5,725,180.13	26.10%
St. Function:210	Support Services-Pupil	4,178,712.00	1,491.56	1,177,158.23	1,767,954.77	28.17%
St. Function:220	Support Services-Inst Staff	3,741,471.00	43,742.97	980,596.39	1,454,819.61	26.21%
St. Function:230	Support Services-General Admin	793,531.00	1,900.37	361,736.48	371,589.52	45.59%
St. Function:240	Support Services-School Admin	2,584,742.00	5,560.64	672,046.36	1,413,188.64	26.00%
St. Function:250	Support Services-Business	810,588.00	7,916.00	316,307.31	413,412.69	39.02%
St. Function:260	Operations and Maintenance	5,965,755.00	94,783.11	1,938,115.20	3,401,969.80	32.49%
St. Function:270	Pupil Transportation Services	978,544.00	5,685.00	259,932.98	59,750.02	26.56%
St. Function:280	Support Services-Central	2,185,108.00	22,061.29	780,564.11	696,783.89	35.72%
St. Function:290	Support Services-Other	813,672.00	73,680.75	161,525.28	355,205.01	19.85%
St. Function:330	Community Activities	330,297.00	0.00	105,254.24	(86,723.63)	31.87%
St. Function:390	Other Community Services	393,000.00	537.04	143,710.38	68,512.48	36.57%
St. Function:440	Pymts to Other Govmnt	293,000.00	0.00	0.00	266,665.00	0.00%
St. Function:510	Debt Services - Long Term Only	33,000.00	0.00	0.00	33,000.00	0.00%
St. Function:600	Transfers Out	293,000.00	0.00	11,343.75	280,744.25	3.87%
	Expense Total:	56,392,202.00	552,271.99	15,936,385.89	29,817,758.87	28.26%
	Grand Total:	-529,806.00		-12,215,697.18	12,675,662.18	

Hazel Park Schools

Check Register by Fund

Check Date From 10/1/2024 TO 10/31/2024

Check Date	Check#	PE ID	Vendor Name	PO#	Amount
Fund: 110					
10/04/2024	EH 00001285	100045	A & I ENTERPRISES		174,643.14
10/04/2024	EH 00001286	100550	AMAZON CAPITAL SERVICES INC	P2500103	1,177.48
10/04/2024	EH 00001287	100503	HEMPLE, CHARLES		80.00
10/04/2024	EH 00001288	100745	KSS ENTERPRISES		9,016.03
10/04/2024	EH 00001289	101330	MICHIGAN STAGE		9,000.00
10/04/2024	EH 00001290	100397	SCHOOL SPECIALTY	P2500094	4,721.44
10/04/2024	HP 00504011	101392	ACCELERATE4KIDS FOUNDATION		2,400.00
10/04/2024	HP 00504012	101162	ALRO STEEL CORPORATION		625.19
10/04/2024	HP 00504014	100354	AUTO ZONE		216.71
10/04/2024	HP 00504015	100448	CDW-G	P2500090	37,705.05
10/04/2024	HP 00504016	100322	CITY HAZEL PARK WATER		4,946.38
10/04/2024	HP 00504017	101449	DCA PRODUCTS INC		1,063.00
10/04/2024	HP 00504018	100361	DOWNRIVER REFRIGERATION SUPPLY		279.33
10/04/2024	HP 00504019	100313	DTE ENERGY		1,192.33
10/04/2024	HP 00504021	100446	FAR THERAPEUTIC & PERFORMING ARTS		168.75
10/04/2024	HP 00504022	100455	GRAINGER		36.89
10/04/2024	HP 00504023	100707	HARRIS, JEFFREY		40.00
10/04/2024	HP 00504024	101435	HERRON, CHLOE		80.00
10/04/2024	HP 00504025	101138	HODGSON, JASON		120.00
10/04/2024	HP 00504026	100830	INTERACTIVE ENERGY GROUP LLC		264.15
10/04/2024	HP 00504027	100521	INTERNATIONAL PLUMBING CO		14,830.00
10/04/2024	HP 00504028	101419	LIVING ARTS		1,250.00
10/04/2024	HP 00504029	100089	MCNAUGHTON-MCKAY ELECTRIC COMP		263.05
10/04/2024	HP 00504030	100481	OAKLAND COMMUNITY COLLEGE		1,209.75
10/04/2024	HP 00504031	101447	PHAUP, DANNY RAY		40.00
10/04/2024	HP 00504032	101448	POUGET, GAGE		104.48
10/04/2024	HP 00504033	100468	PROGRESSIVE PLUMBING SUPPLY		130.68
10/04/2024	HP 00504034	100525	ROBERT BROOKE & ASSOCIATES INC	P2500091	563.38
10/04/2024	HP 00504035	100796	SAVVAS LEARNING COMPANY LLC	P2500098	910.00
10/04/2024	HP 00504036	101434	SCOTT, RONALD		40.00

User: MILLERM - Matthew Miller Page 11/04/2024

Report: OSAP5009 - OSAP5009: Check Register by Fund 1 Current Time: 09:29:49

Selection:

OH_DTL.[oh_ck_dt] <= '10/31/2024' AND OH_DTL.[oh_ck_dt] >= '10/01/2024'

Hazel Park Schools

Check Register by Fund

Check Date From 10/1/2024 TO 10/31/2024

Check Date	Check#	PE ID	Vendor Name	PO#	Amount
10/04/2024	HP 00504037	101431	TIMS GLASS INC		120.00
10/04/2024	HP 00504039	100364	VIGILANTE SECURITY INC		179.00
10/04/2024	HP 00504040	100378	BUCKLES & BUCKLES		103.33
10/04/2024	HP 00504041	100512	CHAPTER 13 TRUSTEE - T. TERRY		1,115.00
10/04/2024	HP 00504042	100609	DAVID RUSKIN		556.58
10/04/2024	HP 00504043	100387	MISDU		551.60
10/04/2024	HP 00504044	101139	SCHEER GREEN AND BURKE CO. LPA		356.73
10/04/2024	HP 00504045	101439	VELO LAW OFFICE		100.00
10/14/2024	EH 00001291	100351	AIRGAS GREAT LAKES		59.65
10/14/2024	EH 00001292	100550	AMAZON CAPITAL SERVICES INC	P2500125	5,051.23
10/14/2024	EII 00001293	100802	CURRICULUM ASSOCIATES LLC	P2500068	21,391.60
10/14/2024	EH 00001294	100430	JG POLY SALES		95.80
10/14/2024	EII 00001295	100745	KSS ENTERPRISES		10,415.65
10/14/2024	EH 00001296	100380	OAKLAND SCHOOLS	P2500142	274.38
10/14/2024	EH 00001297	100538	PROJECT LEAD THE WAY INC	P2500111	1,657.00
10/14/2024	EH 00001298	100428	ROYAL ROOFING		477.00
10/14/2024	EH 00001299	100397	SCHOOL SPECIALTY	P2500105	1,611.86
10/14/2024	EH 00001300	100504	SET SEG		51,382.00
10/14/2024	EII 00001301	100515	STAFF CONNECTIONS LLC		7,084.75
10/14/2024	HP 00504047	100544	ASCENSION MICHIGAN EMPLOYER SOLUTIONS		50.00
10/14/2024	HP 00504048	100354	AUTO ZONE		29.40
10/14/2024	HP 00504049	100935	BIRMINGHAM PUBLIC SCHOOLS		200.00
10/14/2024	HP 00504050	100462	CENGAGE LEARNING	P2500099	26,757.50
10/14/2024	HP 00504051	100309	CONSUMERS ENERGY		3,403.33
10/14/2024	HP 00504052	100185	DETROIT NATIVE SUN NEWSPAPER GROUP		1,180.00
10/14/2024	HP 00504053	100361	DOWNRIVER REFRIGERATION SUPPLY		240.73
10/14/2024	HP 00504054	100313	DTE ENERGY		25,046.21
10/14/2024	HP 00504056	100392	FLINN SCIENTIFIC INC	P2500131	144.10
10/14/2024	HP 00504057	100576	LEARNING WITHOUT TEARS	P2500112	13,674.38
10/14/2024	HP 00504058	101282	LEWIS TIRE SERVICE		445.00
10/14/2024	HP 00504060	100413	MCGRAW HILL BOOK CO	P2500079	2,566.94

User: MILLERM - Matthew Miller

Page 2

Report: OSAP5009 - OSAP5009: Check Register by Fund

Selection:

OH_DTL.[oh_ek_dt] <= '10/31/2024' AND OH_DTL.[oh_ek_dt] >= '10/01/2024'

Current Date: 11/04/2024

Current Time: 09:29:49

Hazel Park Schools

Check Register by Fund

Check Date From 10/1/2024 TO 10/31/2024

Check Date	Check#	PE ID	Vendor Name	PO#	Amount
10/14/2024	HP 00504061	101052	NORTHSTAR MAT SERVICE		696.48
10/14/2024	HP 00504062	100202	ORKIN LLC		160.99
10/14/2024	HP 00504063	101259	POWERSCHOOL GROUP LLC		2,825.00
10/14/2024	HP 00504065	101450	UHY CERTIFIED PUBLIC ACCOUNTANTS		15,375.00
10/14/2024	HP 00504066	101264	ULLIANCE INC		3,441.48
10/14/2024	HP 00504067	100395	WEINGARTZ SUPPLY COMPANY		86.97
10/15/2024	HP 00504069	101268	IDEMIA		66.25
10/15/2024	HP 00504070	101268	IDEMIA		66.25
10/15/2024	HP 00504071	101268	IDEMIA		66.25
10/15/2024	HP 00504072	101268	IDEMIA		66.25
10/15/2024	HP 00504073	101268	IDEMIA		66.25
10/15/2024	HP 00504074	101268	IDEMIA		66.25
10/15/2024	HP 00504075	101268	IDEMIA		66.25
10/15/2024	HP 00504076	101268	IDEMIA		66.25
10/15/2024	HP 00504077	101268	IDEMIA		66.25
10/15/2024	HP 00504078	101268	IDEMIA		66.25
10/28/2024	EH 00001302	100045	A & I ENTERPRISES		198,809.96
10/28/2024	EH 00001303	100351	AIRGAS GREAT LAKES		628.18
10/28/2024	EH 00001304	100550	AMAZON CAPITAL SERVICES INC	P2500133	3,493.64
10/28/2024	EH 00001305	100495	C G NEWSPAPERS		255.00
10/28/2024	EH 00001307	100431	CLARK HILL PLC		15,545.50
10/28/2024	EH 00001308	101071	DAKTRONICS INC		40.00
10/28/2024	EH 00001309	100861	FORTRESS, HEIDI		50.00
10/28/2024	EH 00001310	100503	HEMPLE, CHARLES		120.00
10/28/2024	EH 00001311	100056	HINTON, BEVERLY		50.00
10/28/2024	EH 00001312	100292	INVEST CENTERS LLC		282,687.61
10/28/2024	EH 00001313	100430	JG POLY SALES		367.40
10/28/2024	EH 00001315	100745	KSS ENTERPRISES		9,509.95
10/28/2024	EH 00001316	100520	PEDIATRIC HEALTH CONSULTANTS INC		1,502.68
10/28/2024	EH 00001317	100428	ROYAL ROOFING		939.00
10/28/2024	EH 00001318	100397	SCHOOL SPECIALTY	P2500149	1,943.73

User: MILLERM - Matthew Miller Page 3

Report: OSAP5009 - OSAP5009: Check Register by Fund Current Date: 11/04/2024

Selection:

OH_DTL.[oh_ek_dt] <= '10/31/2024' AND OH_DTL.[oh_ek_dt] >= '10/01/2024' Current Time: 09:29:49

Hazel Park Schools

Check Register by Fund

Check Date From 10/1/2024 TO 10/31/2024

Check Date	Check#	PE ID	Vendor Name	PO#	Amount
10/28/2024	EH 00001319	100515	STAFF CONNECTIONS LLC		7,619.00
10/28/2024	EH 00001320	100357	STAPLES BUSINESS ADVANTGE	P2500126	4,593.62
10/28/2024	EII 00001322	100897	TRANSPORTANT INC		4,339.00
10/28/2024	HP 00504079	101104	AMERICAN READING COMPANY INC	P2500007	3,000.00
10/28/2024	HP 00504080	100544	ASCENSION MICHIGAN EMPLOYER SOLUTIONS		279.00
10/28/2024	HP 00504081	100346	BIG D LOCK & KEY		114.00
10/28/2024	HP 00504082	100735	BURKES SPORT HAVEN	P2500053	260.00
10/28/2024	HP 00504083	100512	CHAPTER 13 TRUSTEE - T. TERRY		1,115.00
10/28/2024	HP 00504084	101457	CHEMSEARCHIFE		2,124.19
10/28/2024	HP 00504085	100321	CITY OF HAZEL PARK		4,214.01
10/28/2024	HP 00504086	100517	CLAWSON PUBLIC SCHOOLS		275.00
10/28/2024	HP 00504087	100308	COCHRANE SUPPLY		151.20
10/28/2024	HP 00504089	100888	CONSTELLATION		187.18
10/28/2024	HP 00504090	100309	CONSUMERS ENERGY		110.08
10/28/2024	IIP 00504091	100609	DAVID RUSKIN		556.58
10/28/2024	HP 00504092	100453	DECKER EQUIPMENT		859.71
10/28/2024	HP 00504093	101403	DETROIT RADIO LLC	P2500019	4,400.00
10/28/2024	HP 00504094	100313	DTE ENERGY		42,192.88
10/28/2024	HP 00504096	100640	FIBER LINK INC		171.75
10/28/2024	HP 00504097	100707	HARRIS, JEFFREY		40.00
10/28/2024	IIP 00504098	101138	HODGSON, JASON		120.00
10/28/2024	HP 00504099	100488	HOME DEPOT CREDIT SERVICES		1,754.88
10/28/2024	IIP 00504100	101224	HOPSKIPDRIVE INC		41,490.75
10/28/2024	HP 00504101	100079	INTEGRITY TESTING & SAFETY ADM		62.00
10/28/2024	HP 00504102	101329	LAKE SHORE CHEERLEADING		150.00
10/28/2024	HP 00504103	101172	LAMPHERE HIGH SCHOOL		150.00
10/28/2024	HP 00504104	101350	LUCAS, ALLISON		240.00
10/28/2024	HP 00504106	100089	MCNAUGHTON-MCKAY ELECTRIC COMP		454.76
10/28/2024	HP 00504107	100589	MILLENNIUM BUSINESS SYSTEMS		468.71
10/28/2024	HP 00504108	100387	MISDU		551.60
10/28/2024	HP 00504111	100001	OAKLAND UNIVERSITY		32,376.00

User: MILLERM - Matthew Miller Page 4

Report: OSAP5009 - OSAP5009: Check Register by Fund Current Date: 11/04/2024

Selection:

OH_DTL.[oh_ek_dt] <= '10/31/2024' AND OH_DTL.[oh_ek_dt] >= '10/01/2024' Current Time: 09:29:49

Hazel Park Schools

Check Register by Fund

Check Date From 10/1/2024 TO 10/31/2024

Check Date	Check#	PE ID	Vendor Name	PO#	Amount
10/28/2024	HP 00504113	100497	OTIS ELEVATOR		2,932.65
10/28/2024	HP 00504114	101456	PRIMEX WIRELESS INC		780.36
10/28/2024	HP 00504115	101455	RPM		137.08
10/28/2024	HP 00504116	101139	SCHEER GREEN AND BURKE CO. LPA		356.73
10/28/2024	HP 00504117	100652	SCHOLASTIC INC	P2500118	7,706.69
10/28/2024	HP 00504118	101372	SCHOOLCRAFT COLLEGE		3,397.00
10/28/2024	HP 00504120	100749	SONITROL GREAT LAKES		569.43
10/28/2024	HP 00504121	100399	STATE OF MICHIGAN - LARA		375.00
10/28/2024	HP 00504122	100235	TOP NOTCH PRINTING LLC		650.00
10/28/2024	HP 00504123	101439	VELO LAW OFFICE		100.00
10/28/2024	HP 00504124	100364	VIGILANTE SECURITY INC		1,064.00
10/28/2024	HP 00504125	100996	WILSON, SHARON		690.00
Fund: 220					1,155,808.87
10/04/2024	EH 00001286	100550	AMAZON CAPITAL SERVICES INC	P2500106	1,278.25
10/04/2024	HP 00504013	101104	AMERICAN READING COMPANY INC	P2500002	5,570.00
10/04/2024	HP 00504020	101132	ENTECH MEDICALL STAFFING		557.89
10/04/2024	HP 00504021	100446	FAR THERAPEUTIC & PERFORMING ARTS		2,531.25
10/14/2024	EH 00001293	100802	CURRICULUM ASSOCIATES LLC	P2500068	1,389.02
10/14/2024	HP 00504055	101132	ENTECH MEDICALL STAFFING		557.89
10/14/2024	HP 00504061	101052	NORTHSTAR MAT SERVICE		123.15
10/28/2024	EH 00001304	100550	AMAZON CAPITAL SERVICES INC	P2500148	1,381.43
10/28/2024	EH 00001320	100357	STAPLES BUSINESS ADVANTGE	P25000050	658.91
10/28/2024	HP 00504088	101459	COHEN, BASYA		408.00
10/28/2024	EP 00504095	101132	ENTECH MEDICALL STAFFING		3,106.27
Fund: 230					17,562.06
10/04/2024	EH 00001286	100550	AMAZON CAPITAL SERVICES INC	P2500114	266.82
10/14/2024	EH 00001292	100550	AMAZON CAPITAL SERVICES INC	P2500124	268.38
10/14/2024	HP 00504061	101052	NORTHSTAR MAT SERVICE		104.51
Fund: 230					639.71

Current Date: 11/04/2024

Current Time: 09:29:49

User: MILLERM - Matthew Miller Page 5

Report: OSAP5009 - OSAP5009: Check Register by Fund Selection:

OH_DTL.[oh_ek_dt] <= '10/31/2024' AND OH_DTL.[oh_ek_dt] >= '10/01/2024'

Hazel Park Schools

Check Register by Fund

Check Date From 10/1/2024 TO 10/31/2024

Check Date	Check#	PE ID	Vendor Name	PO#	Amount
Fund: 250					
10/14/2024	HP 00504059	101315	MACOMB SALES & SERVICE LLC		3,150.00
10/28/2024	EH 00001306	100118	CHARTWELLS DINING SERVICES		282,662.29
10/28/2024	HP 00504105	101315	MACOMB SALES & SERVICE LLC		1,520.40
10/28/2024	HP 00504124	100364	VIGILANTE SECURITY INC		17.50
			Fund 250 Total:		287,350.19
Fund: 290					
10/14/2024	HP 00504046	101124	ALNET		75.00
10/14/2024	HP 00504064	100856	SHOWCASE AMERICA UNLIMITED		500.00
10/14/2024	HP 00504068	101395	WEST MUSIC COMPANY INC		1,318.00
10/28/2024	EH 00001304	100550	AMAZON CAPITAL SERVICES INC	P2500046	70.35
10/28/2024	HP 00504109	101458	MITTEN OUTDOOR ADVENTURE & EVENTS		810.00
10/28/2024	HP 00504110	100481	OAKLAND COMMUNITY COLLEGE		8,483.51
10/28/2024	HP 00504112	101196	ONE CUSTOM CITY		780.00
10/28/2024	HP 00504119	100856	SHOWCASE AMERICA UNLIMITED		150.00
			Fund 290 Total:		12,186.86
Fund: 420					
10/28/2024	EH 00001314	100948	KINGSCOTT ASSOCIATES INC		7,299.73
10/28/2024	EH 00001321	100087	TMP ARCHITECTURE INC		4,926.08
			Fund 420 Total:		12,225.81
			Grand Total:		1,485,773.50

End of Report

Huntington Bank
Commercial Card Summary (P-Card)
For Month Ending - October 2024

<u>Date of Trans</u>	<u>Card Holder</u>	<u>Vendor</u>	<u>Amount</u>
10/31/2024	CARLA BEACH	BJS WHOLESALE #383	100.41
10/17/2024	CARLA BEACH	FAMILY DOLLAR	12.72
10/17/2024	CARLA BEACH	OFFICEMAX/DEPOT 6026	81.90
10/09/2024	CARLA BEACH	AMAZON MARK* P25RT5EP3	194.20
10/23/2024	GINA BREW	SULLIVANS FLEET SERVIC	1,110.51
10/20/2024	GINA BREW	BSN SPORTS LLC	(147.19)
10/06/2024	GINA BREW	SQ *OAKLAND COUNTY TRA	75.00
10/04/2024	GINA BREW	HOLLAND MOTOR HOMES AN	168.91
10/25/2024	JAMIE BUCZKO	CROWNE PLAZA HOTELS	174.90
10/25/2024	JAMIE BUCZKO	CROWNE PLAZA HOTELS	174.90
10/25/2024	JAMIE BUCZKO	CROWNE PLAZA HOTELS	174.90
10/25/2024	JAMIE BUCZKO	AMERICAN RED CROSS	45.00
10/20/2024	JAMIE BUCZKO	NASN	154.00
10/18/2024	JAMIE BUCZKO	MICHASSOCSA	1,481.68
10/10/2024	JAMIE BUCZKO	DELTA	428.95
10/09/2024	JAMIE BUCZKO	AMERICAN ASSOC OF SCHO	795.00
10/08/2024	JAMIE BUCZKO	THE ATS STORE LLC RP	24.97
10/02/2024	JAMIE BUCZKO	OAKLAND SCHOOLS	315.00
10/02/2024	JAMIE BUCZKO	BARNES & NOBLE #2923	889.00
10/31/2024	KRISTY CALES	A 1 FINGERPRINT	75.00
10/30/2024	KRISTY CALES	A 1 FINGERPRINT	75.00
10/29/2024	KRISTY CALES	A 1 FINGERPRINT	75.00
10/29/2024	KRISTY CALES	MDE EDUCATOR LICENSE	45.00
10/29/2024	KRISTY CALES	A 1 FINGERPRINT	75.00
10/20/2024	KRISTY CALES	MDE EDUCATOR LICENSE	405.00
10/17/2024	KRISTY CALES	A 1 FINGERPRINT	75.00
10/16/2024	KRISTY CALES	A 1 FINGERPRINT	75.00
10/16/2024	KRISTY CALES	A 1 FINGERPRINT	75.00
10/15/2024	KRISTY CALES	A 1 FINGERPRINT	75.00
10/15/2024	KRISTY CALES	A 1 FINGERPRINT	75.00
10/11/2024	KRISTY CALES	A 1 FINGERPRINT	75.00
10/11/2024	KRISTY CALES	A 1 FINGERPRINT	75.00
10/10/2024	KRISTY CALES	A 1 FINGERPRINT	75.00
10/09/2024	KRISTY CALES	A 1 FINGERPRINT	75.00
10/09/2024	KRISTY CALES	A 1 FINGERPRINT	75.00
10/09/2024	KRISTY CALES	A 1 FINGERPRINT	75.00
10/08/2024	KRISTY CALES	A 1 FINGERPRINT	75.00
10/08/2024	KRISTY CALES	A 1 FINGERPRINT	75.00
10/08/2024	KRISTY CALES	A 1 FINGERPRINT	75.00
10/08/2024	KRISTY CALES	A 1 FINGERPRINT	75.00
10/02/2024	KRISTY CALES	A 1 FINGERPRINT	75.00
10/02/2024	KRISTY CALES	A 1 FINGERPRINT	75.00
10/02/2024	KRISTY CALES	A 1 FINGERPRINT	75.00
10/02/2024	KRISTY CALES	A 1 FINGERPRINT	75.00
10/01/2024	KRISTY CALES	MDE EDUCATOR LICENSE	45.00
10/01/2024	KRISTY CALES	A 1 FINGERPRINT	75.00
10/01/2024	KRISTY CALES	MDE EDUCATOR LICENSE	45.00
10/31/2024	DEBRA DIMAS	MICHAELS STORES 5073	11.98
10/31/2024	DEBRA DIMAS	WM SUPERCENTER #2559	18.72
10/31/2024	DEBRA DIMAS	LITTLE CAESARS #174	6.35
10/29/2024	DEBRA DIMAS	AMAZON MARK* 9E3XM71B3	24.99
10/28/2024	DEBRA DIMAS	AMAZON RETA* BN7FY71R3	63.18
10/28/2024	DEBRA DIMAS	AMAZON MARK* DC8V409U3	55.02
10/28/2024	DEBRA DIMAS	AMAZON MARK* QH3C70P73	175.79
10/25/2024	DEBRA DIMAS	TST*NEW YORK BAGEL - F	133.00
10/23/2024	DEBRA DIMAS	OTC BRANDS *800-875-8	160.91
10/22/2024	DEBRA DIMAS	AMAZON MKTPL*3L9CA6N13	16.49
10/22/2024	DEBRA DIMAS	AMAZON MKTPL*8W64M84M3	57.45
10/20/2024	DEBRA DIMAS	TST*NEW YORK BAGEL - F	116.40

10/17/2024	DEBRA DIMAS	EDDIES PIZZA	24.00
10/13/2024	DEBRA DIMAS	AMAZON MKTPL*OO1VJ4ES3	6.99
10/11/2024	DEBRA DIMAS	TST*NEW YORK BAGEL - F	156.30
10/10/2024	DEBRA DIMAS	SAMS CLUB #6659	87.64
10/09/2024	DEBRA DIMAS	AMAZON MARK* ST81156Y3	28.98
10/08/2024	DEBRA DIMAS	CVS/PHARMACY #08103	5.88
10/06/2024	DEBRA DIMAS	TST*NEW YORK BAGEL - F	116.40
10/27/2024	KARLA GRAESSLEY	AMAZON RETA* 3X2C92183	21.14
10/25/2024	KARLA GRAESSLEY	SAMSCLUB.COM	1,706.56
10/09/2024	KARLA GRAESSLEY	AMAZON MKTPL*SP9WO7AZ3	17.16
10/06/2024	KARLA GRAESSLEY	HOLIDAY INNS	108.15
10/04/2024	KARLA GRAESSLEY	NOODLES&CO.	28.20
10/01/2024	KARLA GRAESSLEY	AMAZON.COM*GB9OE5HK3	120.93
10/30/2024	KRISTINA HERRON	EA GRAPHICS	872.00
10/29/2024	KRISTINA HERRON	PAYPAL *TENFOURTEEN	110.00
10/27/2024	KRISTINA HERRON	LITTLE CAESARS #174	68.40
10/25/2024	KRISTINA HERRON	PAYPAL *TENFOURTEEN	110.00
10/25/2024	KRISTINA HERRON	CHEERLEADING.COM	511.20
10/23/2024	KRISTINA HERRON	KROGER #447	21.15
10/23/2024	KRISTINA HERRON	PHOTODAY ORDER	142.44
10/20/2024	KRISTINA HERRON	PAYPAL *TENFOURTEEN	110.00
10/20/2024	KRISTINA HERRON	TLF*THRIFTY FLORIST	93.18
10/20/2024	KRISTINA HERRON	DOLLAR TREE	7.95
10/15/2024	KRISTINA HERRON	DICKSSPORTINGGOODS.COM	47.09
10/11/2024	KRISTINA HERRON	PAYPAL *TENFOURTEEN	110.00
10/06/2024	KRISTINA HERRON	MHSAA	216.00
10/04/2024	KRISTINA HERRON	KROGER #447	12.72
10/08/2024	JULIA KENNEDY	U OREGON ONLINE PAYMNT	49.99
10/08/2024	JULIA KENNEDY	U OREGON ONLINE PAYMNT	49.99
10/08/2024	JULIA KENNEDY	U OREGON ONLINE PAYMNT	49.99
10/23/2024	KEVIN KNOBLOCK	OAKLAND SCHOOLS	20.00
10/23/2024	KEVIN KNOBLOCK	OAKLAND SCHOOLS	20.00
10/09/2024	KEVIN KNOBLOCK	OAKLAND SCHOOLS	20.00
10/25/2024	MICHELLE KRAUSE	KENSINGTON METROPARK	90.00
10/13/2024	MICHELLE KRAUSE	WOLCOTT METROPARK	90.00
10/28/2024	HEIDI KUNZ	GFS STORE #1907	45.98
10/28/2024	HEIDI KUNZ	GFS STORE #1907	25.97
10/27/2024	HEIDI KUNZ	BJS WHOLESALE #383	44.52
10/27/2024	HEIDI KUNZ	SAMS CLUB #6659	29.46
10/25/2024	HEIDI KUNZ	AMAZON MKTPL*K24WK1UN3	105.74
10/25/2024	HEIDI KUNZ	AMAZON MARK* T05HB8343	47.99
10/25/2024	HEIDI KUNZ	AMAZON MARK* T05HB8343	35.71
10/22/2024	HEIDI KUNZ	SAMS CLUB #6659	47.84
10/22/2024	HEIDI KUNZ	SAMS CLUB #6659	18.92
10/21/2024	HEIDI KUNZ	AMAZON MARK* D02WW7HR3	181.37
10/21/2024	HEIDI KUNZ	SAMS CLUB #6659	44.74
10/21/2024	HEIDI KUNZ	SAMS CLUB #6659	36.44
10/20/2024	HEIDI KUNZ	AMZN MKTP US*S18QY0X13	4.20
10/18/2024	HEIDI KUNZ	SAMSCLUB #6659	18.36
10/18/2024	HEIDI KUNZ	AMAZON MKTPL*BA1PD6B93	19.99
10/18/2024	HEIDI KUNZ	AMAZON MKTPL*BA1PD6B93	19.95
10/17/2024	HEIDI KUNZ	KROGER #743	18.26
10/16/2024	HEIDI KUNZ	MYBINDING.COM	80.13
10/13/2024	HEIDI KUNZ	AMAZON MKTPL*YJ85G4563	136.33
10/11/2024	HEIDI KUNZ	INCLUSIVE TLC SPECIAL	215.00
10/04/2024	HEIDI KUNZ	SAMSCLUB #6659	20.66
10/28/2024	TAMMY MCHENRY	AMAZON MKTPL*FG2GA37W3	69.57
10/28/2024	TAMMY MCHENRY	AMAZON MARK* TJ98Q46G3	130.77
10/25/2024	TAMMY MCHENRY	MUSIC THEATRE INTL	1,880.00
10/25/2024	TAMMY MCHENRY	EDUCATIONAL THEATRE AS	255.00
10/22/2024	TAMMY MCHENRY	KROGER #447	54.44
10/21/2024	TAMMY MCHENRY	AMAZON.COM*5Y26972H3	141.24
10/20/2024	TAMMY MCHENRY	AMAZON.COM*9N0KE1IQ3	39.45
10/18/2024	TAMMY MCHENRY	PAYPAL *KEVINCONNOR	115.00
10/18/2024	TAMMY MCHENRY	MUSIC THEATRE INTERNAT	95.00

10/17/2024	TAMMY MCHENRY	AMAZON MKTPL*7I2UI7YO3	46.18
10/16/2024	TAMMY MCHENRY	AMAZON MKTPL*AT6W27BV3	62.97
10/16/2024	TAMMY MCHENRY	AMZN MKTP US*MX6B63N53	127.98
10/11/2024	TAMMY MCHENRY	AMAZON MKTPL*6Q80G2FP3	111.26
10/11/2024	TAMMY MCHENRY	SAMS CLUB #6659	320.76
10/09/2024	TAMMY MCHENRY	AMAZON MKTPL*068549TQ3	11.99
10/07/2024	TAMMY MCHENRY	AMAZON MKTPL*OV7AY4V53	9.99
10/07/2024	TAMMY MCHENRY	AMAZON.COM*Z09382IC3	42.84
10/07/2024	TAMMY MCHENRY	THE HOME DEPOT #2731	319.58
10/07/2024	TAMMY MCHENRY	AMAZON.COM*IF6VA9483	23.58
10/06/2024	TAMMY MCHENRY	AMAZON MARK* 887UP3MB3	202.34
10/06/2024	TAMMY MCHENRY	SAMSCLUB #6659	143.82
10/04/2024	TAMMY MCHENRY	AMAZON MKTPL*ZF4084MC3	671.98
10/03/2024	TAMMY MCHENRY	AMAZON MARK* VT4DZ8Y63	21.99
10/02/2024	TAMMY MCHENRY	AMAZON MARK* V02ZK5MS3	23.64
10/31/2024	CORRI NASTASI	TST*NEW YORK BAGEL - F	136.35
10/31/2024	CORRI NASTASI	KROGER GIFT CARDS CS	1,330.00
10/31/2024	CORRI NASTASI	VERELLEN ORCHARDS	105.04
10/30/2024	CORRI NASTASI	WAL-MART #3487	10.98
10/30/2024	CORRI NASTASI	SP ACTIONBASEDLEARNI	483.95
10/30/2024	CORRI NASTASI	AMAZON.COM*W40WN1QU3	11.44
10/30/2024	CORRI NASTASI	AMAZON MKTPL*4H06O8YN3	30.99
10/28/2024	CORRI NASTASI	AMAZON MKTPL*7N5123GT3	97.90
10/27/2024	CORRI NASTASI	AMAZON.COM*Q76TKOFT3	10.38
10/25/2024	CORRI NASTASI	AMAZON.COM*LW0AM4LA3	24.15
10/23/2024	CORRI NASTASI	KROGER #759	60.82
10/23/2024	CORRI NASTASI	AMAZON.COM*FA0VO7O83	34.82
10/22/2024	CORRI NASTASI	AMAZON MARK* CG9TA80O3	58.97
10/20/2024	CORRI NASTASI	SAMS CLUB #6664	90.79
10/17/2024	CORRI NASTASI	TST*NEW YORK BAGEL - F	136.35
10/14/2024	CORRI NASTASI	AMAZON MARK* GU3919TZ3	42.38
10/13/2024	CORRI NASTASI	KROGER #447	9.58
10/11/2024	CORRI NASTASI	AMAZON.COM*RP8GE9G83	6.99
10/11/2024	CORRI NASTASI	AMAZON.COM*S07FE3N33	37.75
10/10/2024	CORRI NASTASI	TST*NEW YORK BAGEL - F	136.35
10/10/2024	CORRI NASTASI	AMZN MKTP US*QB48O7DU3	17.42
10/09/2024	CORRI NASTASI	SAMSCLUB #6664	12.84
10/09/2024	CORRI NASTASI	SAMS CLUB #6664	13.98
10/09/2024	CORRI NASTASI	SAMSCLUB #6664	55.96
10/07/2024	CORRI NASTASI	AMAZON MARK* 8C4TZ8TW3	60.99
10/07/2024	CORRI NASTASI	AMAZON MARK* YF4P36G53	60.99
10/06/2024	CORRI NASTASI	LITTLE CAESARS #174	86.82
10/03/2024	CORRI NASTASI	TST*NEW YORK BAGEL - F	136.35
10/01/2024	CORRI NASTASI	AMAZON MKTPL*UK8RV8GW3	14.99
10/24/2024	SHEILA OKANE	AMAZON MARK* 1M7BQ4JH3	54.22
10/23/2024	SHEILA OKANE	AMAZON MARK* DK9YK2W03	10.59
10/15/2024	SHEILA OKANE	LIBIB.COM	11.00
10/30/2024	MEGAN PAPASIAN-BROADWELL	LRP PUBLICATIONS	55.45
10/23/2024	MEGAN PAPASIAN-BROADWELL	U OF O PBIS APPS	791.65
10/31/2024	JAMES PATERSON	CARD FEE	25.00
10/27/2024	ACCOUNTS PAYABLE	AMAZON MARK* 502R91N03	41.81
10/23/2024	ACCOUNTS PAYABLE	ECOLAB INC	250.00
10/18/2024	ACCOUNTS PAYABLE	ECOLAB INC	99.11
10/18/2024	ACCOUNTS PAYABLE	ECOLAB INC	99.11
10/18/2024	ACCOUNTS PAYABLE	ECOLAB INC	274.01
10/18/2024	ACCOUNTS PAYABLE	ECOLAB INC	174.90
10/17/2024	ACCOUNTS PAYABLE	ECOLAB INC	169.07
10/17/2024	ACCOUNTS PAYABLE	ECOLAB INC	114.27
10/17/2024	ACCOUNTS PAYABLE	ECOLAB INC	99.11
10/16/2024	ACCOUNTS PAYABLE	TMOBILE*AUTO PAY	400.33
10/16/2024	ACCOUNTS PAYABLE	CORRIGAN MOVING SYSTEM	308.68
10/16/2024	ACCOUNTS PAYABLE	REPUBLIC SERVICES TRAS	217.50
10/16/2024	ACCOUNTS PAYABLE	REPUBLIC SERVICES TRAS	4,231.04
10/13/2024	ACCOUNTS PAYABLE	GRINDERZEE	110.84
10/09/2024	ACCOUNTS PAYABLE	ECOLAB INC	99.11

10/09/2024	ACCOUNTS PAYABLE	RIDDELL ALL AMERICAN	129.00
10/09/2024	ACCOUNTS PAYABLE	RIDDELL ALL AMERICAN	289.00
10/09/2024	ACCOUNTS PAYABLE	ECOLAB INC	139.92
10/09/2024	ACCOUNTS PAYABLE	ECOLAB INC	87.45
10/07/2024	ACCOUNTS PAYABLE	AMAZON MKTPL*1V75U7U93	28.97
10/07/2024	ACCOUNTS PAYABLE	AMAZON MARK* 4S2UQ8EO3	35.73
10/06/2024	ACCOUNTS PAYABLE	MPS	312.00
10/02/2024	ACCOUNTS PAYABLE	PROCARE SOFTWARE	368.00
10/01/2024	ACCOUNTS PAYABLE	ECOLAB INC	250.00
10/01/2024	ACCOUNTS PAYABLE	MPS	4,454.92
10/31/2024	GREG RICHARDSON	TONYS ACE HDWE	9.07
10/31/2024	GREG RICHARDSON	TONYS ACE HDWE	17.09
10/31/2024	GREG RICHARDSON	TONYS ACE HDWE	19.16
10/30/2024	GREG RICHARDSON	TONYS ACE HDWE	15.94
10/30/2024	GREG RICHARDSON	TONYS ACE HDWE	45.50
10/29/2024	GREG RICHARDSON	TONYS ACE HDWE	22.96
10/27/2024	GREG RICHARDSON	TONYS ACE HDWE	15.18
10/27/2024	GREG RICHARDSON	TONYS ACE HDWE	630.16
10/27/2024	GREG RICHARDSON	TONYS ACE HDWE	98.07
10/27/2024	GREG RICHARDSON	TONYS ACE HDWE	3.06
10/25/2024	GREG RICHARDSON	TONYS ACE HDWE	46.28
10/25/2024	GREG RICHARDSON	TONYS ACE HDWE	53.16
10/25/2024	GREG RICHARDSON	TONYS ACE HDWE	6.26
10/25/2024	GREG RICHARDSON	TONYS ACE HDWE	8.16
10/24/2024	GREG RICHARDSON	TONYS ACE HDWE	44.45
10/24/2024	GREG RICHARDSON	TONYS ACE HDWE	43.08
10/24/2024	GREG RICHARDSON	TONYS ACE HDWE	35.10
10/23/2024	GREG RICHARDSON	TONYS ACE HDWE	75.95
10/23/2024	GREG RICHARDSON	TONYS ACE HDWE	26.19
10/23/2024	GREG RICHARDSON	TONYS ACE HDWE	24.30
10/23/2024	GREG RICHARDSON	TONYS ACE HDWE	8.64
10/22/2024	GREG RICHARDSON	TONYS ACE HDWE	48.43
10/20/2024	GREG RICHARDSON	TONYS ACE HDWE	77.16
10/20/2024	GREG RICHARDSON	TONYS ACE HDWE	3.16
10/20/2024	GREG RICHARDSON	TONYS ACE HDWE	25.63
10/20/2024	GREG RICHARDSON	TONYS ACE HDWE	5.68
10/18/2024	GREG RICHARDSON	MICHIGAN AIR PRODUCTS	240.00
10/18/2024	GREG RICHARDSON	TONYS ACE HDWE	36.64
10/18/2024	GREG RICHARDSON	TONYS ACE HDWE	16.12
10/17/2024	GREG RICHARDSON	TONYS ACE HDWE	14.42
10/17/2024	GREG RICHARDSON	TONYS ACE HDWE	24.68
10/16/2024	GREG RICHARDSON	TONYS ACE HDWE	75.61
10/15/2024	GREG RICHARDSON	TONYS ACE HDWE	38.54
10/13/2024	GREG RICHARDSON	TONYS ACE HDWE	23.73
10/13/2024	GREG RICHARDSON	TONYS ACE HDWE	70.18
10/13/2024	GREG RICHARDSON	TONYS ACE HDWE	15.75
10/11/2024	GREG RICHARDSON	TONYS ACE HDWE	42.67
10/10/2024	GREG RICHARDSON	TONYS ACE HDWE	44.59
10/09/2024	GREG RICHARDSON	TONYS ACE HDWE	11.04
10/08/2024	GREG RICHARDSON	TONYS ACE HDWE	18.34
10/07/2024	GREG RICHARDSON	DETROIT AIR COMPRESSOR	290.12
10/06/2024	GREG RICHARDSON	TONYS ACE HDWE	41.47
10/04/2024	GREG RICHARDSON	TONYS ACE HDWE	64.57
10/04/2024	GREG RICHARDSON	TONYS ACE HDWE	186.74
10/04/2024	GREG RICHARDSON	TONYS ACE HDWE	63.62
10/03/2024	GREG RICHARDSON	TONYS ACE HDWE	28.49
10/02/2024	GREG RICHARDSON	TONYS ACE HDWE	9.11
10/02/2024	GREG RICHARDSON	TONYS ACE HDWE	30.38
10/01/2024	GREG RICHARDSON	TONYS ACE HDWE	11.38
10/01/2024	GREG RICHARDSON	TONYS ACE HDWE	42.33
10/01/2024	GREG RICHARDSON	TONYS ACE HDWE	24.60
10/31/2024	JOAN RYBINSKI	KROGER #447	73.78
10/25/2024	JOAN RYBINSKI	BJS WHOLESALE #383	221.50
10/24/2024	RAMONA SOULEYRETTE	AWL*PEARSON EDUCATION	235.32
10/22/2024	RAMONA SOULEYRETTE	DOLLAR TREE	36.25

10/22/2024	RAMONA SOULEYRETTE	IMSE	125.00
10/13/2024	RAMONA SOULEYRETTE	EVERYDAYSPEECHSLP	599.99
10/10/2024	RAMONA SOULEYRETTE	AWL*PEARSON EDUCATION	65.70
10/10/2024	RAMONA SOULEYRETTE	AWL*PEARSON EDUCATION	60.00
10/08/2024	RAMONA SOULEYRETTE	BUILDING WINGS LLC	932.85
10/06/2024	RAMONA SOULEYRETTE	AWL*PEARSON EDUCATION	121.40
10/30/2024	ROCHELLE TASSIE	AMAZON MARK* TS5058Q13	166.42
10/27/2024	ROCHELLE TASSIE	AMAZON MKTPL*XC7QP7ED3	168.58
10/27/2024	ROCHELLE TASSIE	AMAZON MARK* AY1PZ12X3	35.99
10/27/2024	ROCHELLE TASSIE	AMAZON MARK* GP93Q7OE3	99.52
10/22/2024	ROCHELLE TASSIE	AMAZON MARK* 5D18Z7G93	263.98
10/20/2024	ROCHELLE TASSIE	AMAZON MARK* 1398Z9XL3	26.99
10/18/2024	ROCHELLE TASSIE	AMAZON.COM*533TI2PO3	79.96
10/15/2024	ROCHELLE TASSIE	AMAZON MARK* S89ON7W33	107.75
10/14/2024	ROCHELLE TASSIE	AMAZON MKTPL*J19FX17H3	192.69
10/14/2024	ROCHELLE TASSIE	AMAZON MKTPL*ZD1ZT7SU3	14.99
10/09/2024	ROCHELLE TASSIE	AMAZON MKTPL*E69OB3NQ3	304.41
10/06/2024	ROCHELLE TASSIE	AMAZON MARK* A900D5AZ3	168.50
10/04/2024	ROCHELLE TASSIE	AMAZON MKTPL*SZ5Z74Y43	14.99
10/04/2024	ROCHELLE TASSIE	AMAZON MKTPL*0245W0TW3	236.13
10/02/2024	ROCHELLE TASSIE	AMAZON MARK* 4T8XI4UH3	277.75
10/27/2024	JR VIKINGS	GRINDERZEE	82.65
10/27/2024	JR VIKINGS	LITTLE CAESARS #174	77.47
10/25/2024	JR VIKINGS	NUWAYCOMBAT	671.12
10/25/2024	JR VIKINGS	SAMS CLUB #6659	65.24
10/22/2024	JR VIKINGS	SQ *CONCESSIONS - HPS	89.00
10/17/2024	JR VIKINGS	SAMS CLUB #6659	201.08
10/06/2024	JR VIKINGS	AMAZON MKTPL*HZ9TT9133	31.48
10/02/2024	JR VIKINGS	SQ *ALLSTAR CREATIONZ	157.20
10/02/2024	JR VIKINGS	AMAZON MARK* EJ6XT34H3	9.41
10/01/2024	JR VIKINGS	MEIJER # 222	73.30
10/01/2024	JR VIKINGS	SAMSCLUB #6659	111.40
10/27/2024	RYANN VOSS	DECKER EQUIP SCHOOL FI	6,434.05
10/27/2024	RYANN VOSS	DECKER EQUIP SCHOOL FI	2,254.20
10/27/2024	RYANN VOSS	AMZN MKTP US*XP0VR4U23	149.99
10/24/2024	RYANN VOSS	DECKER EQUIP SCHOOL FI	4,432.60
10/24/2024	RYANN VOSS	DECKER EQUIP SCHOOL FI	5,771.35
10/24/2024	RYANN VOSS	AMAZON.COM*6774E4C83	17.99
10/23/2024	RYANN VOSS	DECKER EQUIP SCHOOL FI	1,509.35
10/23/2024	RYANN VOSS	DECKER EQUIP SCHOOL FI	2,525.15
10/16/2024	RYANN VOSS	DECKER EQUIP SCHOOL FI	2,668.69
10/13/2024	RYANN VOSS	SETON IDENTIFICATION P	231.61
10/10/2024	RYANN VOSS	DECKER EQUIP SCHOOL FI	105.15
10/08/2024	RYANN VOSS	VISTAPRINT	50.86
10/04/2024	RYANN VOSS	DECKER EQUIP SCHOOL FI	771.20
10/02/2024	RYANN VOSS	MICHASSOCSA	198.00
10/02/2024	RYANN VOSS	ALLSTATE SIGN & PLAQUE	438.70
10/01/2024	RYANN VOSS	DECKER EQUIP SCHOOL FI	599.78
10/27/2024	BRADLEY WILKINS	MICRO CENTER #055-RETA	174.95
10/27/2024	BRADLEY WILKINS	ALOHI * FAXPLUS	199.79
10/23/2024	BRADLEY WILKINS	CELLULAR GENIUS	535.60
10/20/2024	BRADLEY WILKINS	PRECISION ROLLER	64.47
10/20/2024	BRADLEY WILKINS	CDW GOVT #ZR00567492	5,000.00
10/20/2024	BRADLEY WILKINS	AMAZON MARK* 4A6BU8J93	31.48
10/18/2024	BRADLEY WILKINS	FACEBK *589LBBCH72	(10.00)
10/18/2024	BRADLEY WILKINS	IN *BERESFORD COMPANY	305.00
10/18/2024	BRADLEY WILKINS	FACEBK *CYUWXBLH72	(13.00)
10/18/2024	BRADLEY WILKINS	FACEBK *KUPUXBLH72	(9.00)
10/18/2024	BRADLEY WILKINS	FACEBK *LEZXQB4J72	(6.00)
10/18/2024	BRADLEY WILKINS	FACEBK *G78YDBQH72	(8.00)
10/18/2024	BRADLEY WILKINS	FACEBK *LQXQJC8J72	(15.00)
10/18/2024	BRADLEY WILKINS	FACEBK *NJCYQB4J72	(7.00)
10/18/2024	BRADLEY WILKINS	FACEBK *XZ3MBBCH72	(11.00)
10/18/2024	BRADLEY WILKINS	FACEBK *623ETBGH72	(16.71)
10/18/2024	BRADLEY WILKINS	FACEBK *5BEKZFY8E2	63.00

10/18/2024	BRADLEY WILKINS	FACEBK *55ZFJC8J72	(6.01)
10/17/2024	BRADLEY WILKINS	FACEBK *55ZFJC8J72	6.01
10/17/2024	BRADLEY WILKINS	FACEBK *8AKYJDC8E2	57.00
10/17/2024	BRADLEY WILKINS	AMZN MKTP US*079XF0NH3	1,175.22
10/17/2024	BRADLEY WILKINS	FACEBK *LEZXQB4J72	6.00
10/17/2024	BRADLEY WILKINS	FACEBK *NJCYQB4J72	7.00
10/17/2024	BRADLEY WILKINS	AMAZON MKTPL*2O4RL2LX3	66.07
10/17/2024	BRADLEY WILKINS	CELLULAR GENIUS	535.60
10/17/2024	BRADLEY WILKINS	FACEBK *CYUWXBLH72	13.00
10/17/2024	BRADLEY WILKINS	FACEBK *623ETBGH72	16.71
10/17/2024	BRADLEY WILKINS	FACEBK *G78YDBQH72	8.00
10/17/2024	BRADLEY WILKINS	FACEBK *KUPUXBLH72	9.00
10/17/2024	BRADLEY WILKINS	FACEBK *LQXQJC8J72	15.00
10/17/2024	BRADLEY WILKINS	FACEBK *XZ3MBBCH72	11.00
10/17/2024	BRADLEY WILKINS	FACEBK *589LBBCH72	10.00
10/16/2024	BRADLEY WILKINS	SPECTRUM WIRELESS (USA	3,437.01
10/15/2024	BRADLEY WILKINS	TEL SYSTEMS	3,938.39
10/15/2024	BRADLEY WILKINS	AMZN MKTP US*OF2YZ23O3	699.69
10/14/2024	BRADLEY WILKINS	AMAZON MARK* PB3283EY3	190.00
10/13/2024	BRADLEY WILKINS	APPLE.COM/BILL	105.99
10/11/2024	BRADLEY WILKINS	BLUE CHIP HOTEL & CASI	574.53
10/11/2024	BRADLEY WILKINS	BLUE CHIP HOTEL & CASI	278.49
10/11/2024	BRADLEY WILKINS	BLUE CHIP HOTEL & CASI	278.49
10/11/2024	BRADLEY WILKINS	BLUE CHIP HOTEL & CASI	278.49
10/09/2024	BRADLEY WILKINS	KNUCKLEHEADS SPORTS BA	84.50
10/09/2024	BRADLEY WILKINS	GALVESTON STEAKHOUSE I	150.13
10/07/2024	BRADLEY WILKINS	TST* RITZ KLUB TAVERN	53.61
10/07/2024	BRADLEY WILKINS	AMAZON MARK* ZI8WS1PF0	56.93
10/06/2024	BRADLEY WILKINS	SOUNDTRAP US INC	399.00
10/04/2024	BRADLEY WILKINS	AMAZON.COM*3M2253193	1,405.99
10/03/2024	BRADLEY WILKINS	VOXTELESYS LLC	1,562.72
10/02/2024	BRADLEY WILKINS	GOOGLE *CLOUD X46RKZ	9.67
10/01/2024	BRADLEY WILKINS	PRECISION ROLLER	102.51
10/31/2024	SHANA WILLIAMS	JAVA HUTT CAFE	8.80
10/30/2024	SHANA WILLIAMS	PAYPAL *MHHPCHAMBER	100.00
10/25/2024	SHANA WILLIAMS	TST*ANITAS KITCHEN - F	37.74
10/30/2024	DANIEL WROBBEL	SAAD WHOLESALE MEATS	374.00
10/28/2024	DANIEL WROBBEL	SAAD WHOLESALE MEATS	(499.00)
10/27/2024	DANIEL WROBBEL	THE WEBSTAUANT STORE	(52.37)
10/27/2024	DANIEL WROBBEL	THE WEBSTAUANT STORE	(0.20)
10/27/2024	DANIEL WROBBEL	THE WEBSTAUANT STORE	959.17
10/25/2024	DANIEL WROBBEL	SAAD WHOLESALE MEATS	499.00
10/22/2024	DANIEL WROBBEL	AK MOBILE NOTARY	104.73
10/22/2024	DANIEL WROBBEL	SAMSCLUB.COM	124.78
10/16/2024	DANIEL WROBBEL	GFS STORE #1907	240.44
10/16/2024	DANIEL WROBBEL	TOP NOTCH PRINTING	200.00
10/11/2024	DANIEL WROBBEL	MEIJER268 *PRODUCT	(450.72)
10/11/2024	DANIEL WROBBEL	MEIJER268 *PRODUCT	(35.00)
10/06/2024	DANIEL WROBBEL	THE WEBSTAUANT STORE	17.65
10/31/2024	LINDA YATES	WILLIAM H SADLIER	201.87
10/31/2024	LINDA YATES	OAKLAND SCHOOLS	50.00
10/29/2024	LINDA YATES	PROJECT LEAD THE WAY,	200.75
10/24/2024	LINDA YATES	GVSU WEB PAYMENTS	10.00
10/24/2024	LINDA YATES	AFP*MICHIGAN ASSOCIATI	250.00
10/24/2024	LINDA YATES	OAKLAND SCHOOLS	60.00
10/22/2024	LINDA YATES	SP HARKLA	100.00
10/22/2024	LINDA YATES	AMERICAN COUNCIL ON TH	350.00
10/17/2024	LINDA YATES	FSP*SHAPE-MICHIGAN	193.00
10/17/2024	LINDA YATES	COLLEGEBOARD WORKSHOPS	175.00
10/17/2024	LINDA YATES	SP HARKLA	125.00
10/17/2024	LINDA YATES	OAKLAND SCHOOLS	20.00
10/17/2024	LINDA YATES	OAKLAND SCHOOLS	20.00
10/16/2024	LINDA YATES	OAKLAND SCHOOLS	20.00
10/15/2024	LINDA YATES	AFP*MICHIGAN ASSOCIATI	250.00
10/13/2024	LINDA YATES	OAKLAND SCHOOLS	(25.00)

10/09/2024	LINDA YATES	OAKLAND SCHOOLS	25.00
10/09/2024	LINDA YATES	NYTIMES DISC*	4.00
10/09/2024	LINDA YATES	KROGER #602	25.00
10/09/2024	LINDA YATES	OAKLAND SCHOOLS	60.00
10/08/2024	LINDA YATES	SP ROBOLINK	553.11
10/04/2024	LINDA YATES	TOP NOTCH PRINTING	200.00
10/04/2024	LINDA YATES	KROGER #602	25.00
10/03/2024	LINDA YATES	AFP*MICHIGAN ASSOCIATI	250.00
10/01/2024	LINDA YATES	MICHIGAN ASSOCIATION O	75.00

101,744.98



Ford Administration
1620 E. Elza, Hazel Park, MI 48030 | 248-658-5200 | F: 248-544-5223
www.hazelparkschools.org

To: Hazel Park Board of Education
From: Dr. Amy Kruppe, Superintendent
Subject: Personnel Recommendations Report
Date: November 18, 2024

Please see the personnel actions as indicated on the *Hazel Park Board of Education Personnel Recommendations* report for the November 18, 2024 Board of Education regular meeting. The packet also includes supporting documentation.

Goal Statement - Resources

The Hazel Park School District will maximize its resources to assure high quality education by fostering financial stability, preserving and utilizing quality facilities, and integrating state-of-the-art technology.

Recommendation

That the Board of Education approve the Personnel Recommendations as presented.

**APPROVED AND RECOMMENDED FOR
BOARD ACTION**

Amy Y. Kruppe, Ed.D.
Superintendent



Attendee	EVENT	DATES OF EVENT	Location	ESTIMATED COST
Battice, Sarah	Tobi Dynavox Winter Conference	11/14/14 - 11/15/24	Virtual	\$0.00
Bryant, Taylor	School Social Worker: Community of Practice: Election Day Event	11/5/24	Walsh College	\$20.00
Davanzo, Cady	Oakland Schools 5th Annual Early Childhood Special Education Conference	11/15/24	Oakland Schools	\$20.00
Pierce, Whitney	SHAPE Conference	11/7/24 - 11/8/24	Lansing, MI	\$190.00
Stevens, Nancy	Applied Physical Training (Advanced NCI)	10/22/24 - 10/5/24	Pontiac, MI	\$0.00
Ulrych, Katherine	Improving Focus & Behavior in the Classroom	11/20/24	Virtual	\$100.00
Parmelee, Sarah	AVMR 2 (Math Recovery)	3/5/25, 3/28/25, 4/23/25, 5/13/25	Oakland Schools	\$0.00
Westbury, Lauri	AVMR 2 (Math Recovery)	3/5/25, 3/28/25, 4/23/25, 5/13/25	Oakland Schools	\$0.00
Hill, Shymia	ACTFL Annual Conference	11/22/24 - 11/24/24	Philadelphia, Pa	\$350.00
Agueros, Heather	GSRP Annual Recruitment and Enrollment	11/22/24	Oakland Schools	\$0.00
Jones, Kathy	Exploring Military Careers at the Selfridge Air National Gaurd Base	11/5/24	Selfidge Air Base	\$0.00
O'Brieht, Karli	Early Childhood - Providing Behavior Support in the Early Childhood Classroom	11/1/24	Virtual	\$10.00
Page, Hope	IEP Essentials (3 day event)	2/4/25; 2/25/25; 3/4/25	Oakland Schools	\$60.00
Zeigler, Radiance	MASP Annual Conference	10/28/24-10/29/24	Novi, MI	\$250.00
Cucchiara, Jill	GSRP Annual Recruitment and Enrollment	11/22/24	Oakland Schools	\$0.00
Roberts, Sherri	Oakland Schools 5th Annual Early Childhood Special Education Conference	11/15/24	Oakland Schools	\$20.00
Barshaw, Lenore	OCTA Meetings	10/15/24; 11/19/24; 12/17/24; 1/21/25; 2/21/25; 3/18/25; 4/22/25; 5/20/25	Oakland Schools	\$50.00
Bellini, James	School Social Worker: Community of Practice: Election Day Event	11/5/24	Walsh College	\$0.00
Baber, Brendan	Adult Transition Programs and Services (ATPS)	12/19/24; 3/20/25	Oakland Schools	\$75.00
Bowker, Ashley	Assistive Technology P.L.A.Y.D.A.T.E.	12/13/24	Ann Arbor, MI	\$0.00
Brossard, Lee	AVMR1 (Math Recovery)	11/1/24, 11/15/24, 12/4/24, 12/11/24	Ford Building	\$0.00
Brossard, Lee	Comprehensive Orton-Gillingham Plus Virtual Course	11/18/24 - 11/22/24	Virtual	\$0.00
Geldhof, Samantha	3P Network	10/24/24, 6/18/25, 6/19/25	Cranbrook Inst. of Science	\$0.00
Page, Hope	AVMR1 Math Recovery Intervention Training	11/1/24, 11/15/24, 12/4/24, 12/11/24	Ford Building	\$0.00
Tompkins, Susan	Comprehensive Orton-Gillingham Plus Virtual Course	10/8/24, 10/9/24, 1/6.25, 1/7/25,	Virtual	\$0.00
Williams, Shearon	Using the CETA to Promote Evidence-Based Classroom Practices	1/27/25; 2/10/25; 2/24/25; 3/10/25; 4/14/25; 5/12/25	Zoom/Virtual	\$0.00



Ford Administration
1620 E. Elza, Hazel Park, MI 48030 | 248-658-5200 | F: 248-544-5223
www.hazelparkschools.org

To: Hazel Park Board of Education
From: Dr. Amy Kruppe, Superintendent
Subject: 2025 MASA Midwinter Conference
Date: November 18, 2024

MASA's Midwinter Conference is an annual members-only event that includes carefully curated learning opportunities specifically for Michigan's district leaders. Participants will engage with educational thought leaders, explore opportunities to improve the education landscape, and walk away with innovative strategies to advance both their district and their own professional development.

The insights and knowledge gained from this conference will directly contribute to our ongoing efforts to enhance education within our district. We believe that participating in such events is essential for staying at the forefront of educational advancements and best practices. Below you will find a detailed breakdown of estimated costs for your review.

Registration: \$ 550
Hotel: \$ 609 (3 nights)
Total trip: \$ 1,159

Fund: General fund.

Goal Statement

Curriculum & Instruction: Hazel Park Schools will develop innovative, independent, and persistent learners who think critically, communicate effectively, and positively influence the local and global community.

Recommendation

That the Board of Education approve Dr Kruppe to attend the 2025 MASA Midwinter Conference, as presented.

**APPROVED AND RECOMMENDED FOR
BOARD ACTION**

Amy Y. Kruppe, Ed.D.
Superintendent





HAZEL PARK
SCHOOLS



Ford Administration
1620 E. Elza, Hazel Park, MI 48030 | 248-658-5200 | F: 248-544-5223
www.hazelparkschools.org

To: Board of Education
From: Dr. Amy Kruppe, Superintendent
Subject: Longfellow RFP
Date: November 18, 2024

This memo presents the responses received to the Request for Proposal (RFP) issued for the renovations and updates required to transition the Longfellow building into the Hazel Park Community Center. The work proposed in each response will ensure the facility is appropriately equipped to support a range of community programs and activities.

The RFP's included with this memo has detailed proposals outlining work scopes, projected timelines, and cost estimates. The first proposal offers a comprehensive renovation package with an anticipated completion date of May 2025, while the second response anticipates completion by June 2025. Please review the attached summaries.

Funding Sources: Community Center Grant

Strategic Goal Alignment:

Resources: The Hazel Park School District will maximize its resources to assure high quality education by fostering financial stability, preserving and utilizing quality facilities, and integrating state-of-the-art technology.

Community Relations: The Hazel Park School District through strong community relations and collaboration with all stakeholders will develop high-achieving students.

Recommendation

That the Board of Education approve the RFP for the Longfellow Community Center, as presented..

**APPROVED AND RECOMMENDED FOR
BOARD ACTION**

Amy Y. Kruppe, Ed.D.
Superintendent



Post Bid Review Form

Project: Hazel Park Community Center Remodeling
A/E #: 4500.070
Date / Time: 10/30/2024 10:00 AM
Bid Package: Full Scope
Attendees: Tony Dattilio, Keith Norush, Sara King, Ryan Alm, Rebecca Tritt

- 1. Base Bid: **\$544,700.00** Include Addenda #s: **1**
- 5. Alternates? Yes No
- 6. Voluntary Alternates? Yes No
- 7. Mark up for additional work
 - SELF-PERFORMED **9%**
 - MATERIAL **9%**
 - SUB-CONTRACTOR **9%**
 - LABOR **9%**
- 9. Union Labor? Yes No
- 11. Sales Tax Included? Yes No
- 12. Warranty Included? Yes No
- 13. Permits Included? Yes No
- 14. Cleanup Included? Yes No
- 15. Reviewed expectations for safe / clean behaviors? Yes No
 - Temporary protection required? Yes No
 - Temporary protection included? Yes No
- 16. Temporary heat required? Yes No
 - Temporary heat included? Yes No
- 18. Has contractor visited site? Yes No
- 19. Does Bid contain qualifications or exclusions to scope of work? Yes No
- 20. Were any exceptions to contract terms and conditions noted in Bid? Yes No
- 21. Has the contractor reviewed the insurance coverage and limits Yes No

PORTAGE
 950 Trade Centre Way, Suite 130
 Portage, MI 49002
 T:800.632.7815

GRAND RAPIDS
 801 Broadway NW, Suite 306
 Grand Rapids, MI 49504
 T: 800.632.7815

CHELSEA
 300 N. Main Street, Suite 204
 Chelsea, MI 48118
 T:800.632.7815

ROYAL OAK
 818 W. Eleven Mile Road
 Royal Oak, MI 48067
 T: 800.632.7815

- Can they obtain the specified coverage limits? Yes No
22. Does the contractor understand the schedule start and completion dates? Yes No
- Have they included all costs to meet them? Yes No
23. Time required for shop drawings and submittals *4-6 weeks*
24. Does Bid account for all overtime and shift time necessary to complete work and meet schedule? Yes No
25. Contractor’s proposed field organization:
PM – TBD
Super – TBD
Estimator - Keith Norush
26. Contractor’s site requirements (i.e. site trailer, parking, etc.):
No site needs, just parking for contractors
27. Proposed Major Contractor:
TMX Contracting
Royal West Roofing
28. Does the Contractor have an understanding of the Owner facilities, utilities, power, storage, etc.?.? Yes No
29. Does the Contractor have a safety plan? Yes No
- Name of Safety Representative: *Sara King & Anna Halstead*
30. Does Contractor have documented procedures for process control (including drawings, submittals, inspection/surveillance, and training)? Yes No
- OneDrive/Excel logging, Raken app*
Job specific safety training, EMR .73
31. Bid Price Summary
- | | | |
|----|--------------------|----------------------------|
| a. | BASE BID | \$544,700.00 |
| b. | Alt A1 | \$34,375.00 |
| c. | Alt A2 | \$44,900.00 |
| d. | Alt M1 | \$249,000.00 |
| | TOTAL | <u>\$872,975.00</u> |

PORTAGE
 950 Trade Centre Way, Suite 130
 Portage, MI 49002
 T:800.632.7815

GRAND RAPIDS
 801 Broadway NW, Suite 306
 Grand Rapids, MI 49504
 T: 800.632.7815

CHELSEA
 300 N. Main Street, Suite 204
 Chelsea, MI 48118
 T:800.632.7815

ROYAL OAK
 818 W. Eleven Mile Road
 Royal Oak, MI 48067
 T: 800.632.7815

32. Remarks or comments:

Access Controls included in bid

This conference is in no way intended to indicate the award of a contract.

For: Summit

Signed:

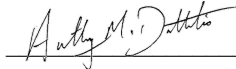

Print Name:

Tony Dattilio

Date:

10/31/2024

Kingscott Associates, Inc.



Ryan Alm

10/30/2024

PORTAGE

950 Trade Centre Way, Suite 130
Portage, MI 49002
T:800.632.7815

GRAND RAPIDS

801 Broadway NW, Suite 306
Grand Rapids, MI 49504
T: 800.632.7815

CHELSEA

300 N. Main Street, Suite 204
Chelsea, MI 48118
T:800.632.7815

ROYAL OAK

818 W. Eleven Mile Road
Royal Oak, MI 48067
T: 800.632.7815

PROPOSAL

To: Hazel Park Schools
 1620 E. Elza
 Hazel Park, MI 48030

Project: Longfellow Community Center Remodel

Location: 570 E. Mapledale Ave., Hazel Park, MI 48030

Attn: Ryan Alm
 586-764-0112

Arch/Eng'r: Kingscott Associates, Inc.
 Arch/Eng'r Project No.: 4500.07

We propose to provide the following described scope for the sum of..... **\$544,700.00**

Labor, materials, equipment and supervision to complete the Longfellow Community Center Remodel project per drawings dated 9/25/24, specifications dated 9/25/24 and addendum 1 dated 10/14/24.

- Alternate M1 **\$34,375.00**
- Alternate 1 **\$44,900.00**
- Alternate 2 **\$249,000.00**

Total for all alternates and base bid combined. **\$872,975.00**

Please Note:

- A)
- B)

Proposal price includes **ALLOWANCE(S)** for:

Permits (e.g. bldg., sewer, water, R.O.W., soil erosion) and related fees (e.g. inspection, tap, assessment, review, surety) of. **\$7,500.00**
Public utility charges (including meters) of..... **\$0.00**

Terms and Conditions

1. This proposal is based on:
 - (a) Price(s) and fee(s) firm for 20 days (see item 1f for exceptions).
 - (b) AIA Document A201 2007 edition General Conditions (unless stated otherwise in bid documents).
 - (c) Construction performed during regular work hours (except minor tie-in work or specifically stated in proposal).
 - (d) Payment terms net 30 days after our invoice is submitted.
 - (e) Owner promptly providing to us a recorded Notice of Commencement and copies of all Notices of Furnishings and/or requests for Notices of Commencement.
 - (f) CPI not increasing more than 1% and/or material/energy prices not increasing from date of this proposal.
2. This proposal excludes:
 - (a) Building and site conditions such as dewatering, unstable ground, interferences (e.g. utilities, rock, concrete, conduits), locating utility lines or other problematic conditions.
 - (b) Recognition, testing and/or removal of contaminated or hazardous gases/materials, including asbestos and lead (proposal assumes the owner will provide written notification to us if there are any contaminated or hazardous gases/materials, including asbestos and lead, on the premises with specific location(s) before construction begins).
 - (c) Winter conditions and associated costs.
 - (d) Liability in excess of our insurance coverage (proposal assumes property insurance by owner).
 - (e) General conditions and supervision costs for scope changes and owner/architect caused delays.
 - (f) Liability for any loss, damage or delay caused by acts beyond our control including acts of God, weather, failure of supplier/mfr. to perform and labor disputes.
 - (g) 3rd party inspections/testing and SWPPP for stormwater.

This proposal shall be the contract agreement or this proposal shall be part of a separate owner/contractor agreement.

Purchaser: _____

The Summit Company, Inc.

Sign/Date: _____



Keith Norush

Kingscott Associates, Inc.
Architects/Engineers
Portage, Michigan

Hazel Park Schools
Longfellow Community Center Remodeling
Hazel Park, Michigan

BID FORM

Owner:
Hazel Park Schools
Hazel Park, Michigan

The undersigned, having carefully examined the Notice to Bidders, Instruction to Bidders, the premise and conditions affecting this work, together with drawings and specifications for the **Hazel Park Schools, Longfellow Community Center Remodeling, Hazel Park, Michigan** and other documents related thereto, does hereby propose to furnish labor, materials, services and equipment necessary to complete all work, called for by and in accordance with the drawings and specifications for same, dated **September 25, 2024** including addenda numbered

#1 Dated 10/14/24.

TIME OF COMPLETION

The undersigned agrees to start work upon receipt of the Contract and shall achieve Final Completion by **July 1, 2025**. Construction is to happen beginning **January 1, 2025** with substantial completion on or before **June 1, 2025**. (Note: Contract will be issued after the November 4, 2024 School Board Meeting)

BID SECURITY

Enclosed herewith find (Certified Check), (Cashier's Check), (Bid Bond), in the amount of \$ _____ being 5% percent of the maximum bid herein, made payable to **Hazel Park Schools**. The proceeds of which are to remain the property of the **Hazel Park Schools**, if bidder does not, within ten (10) days after notice of acceptance of bid, enter into a written contract.

EXCEPTIONS AND/OR SUBSTITUTIONS

We have submitted our proposal(s) complete as specified and in accordance with the Construction Documents WITH/WITHOUT (circle one) exceptions or substitutions. (Explain the exceptions or substitutions below).

BIDDER STATUS:

(Check One)

 Individual Partnership Corporation

Submitted By:
Company

The Summit Company, Inc.

Address

13191 Wayne Rd., Livonia, MI 48150

Telephone/Fax

734-261-3500

Email

Tdattilio@summitcompany.net

Signature/Date

Tony M. Dattilio 10/22/24

Print Name/Title

Tony Dattilio, President

SCHEDULE

The proposed schedule may be a deciding factor in the selection of the successful bidder. Please indicate the proposed schedule as follows:

Proposed Material Delivery Date: Jan 31, 2025

Proposed Installation Start Date: Feb 1, 2025

Proposed Completion Date: May, 2025

END OF SECTION

Kingscott Associates, Inc.
Architects/Engineers
Portage, Michigan

Hazel Park Schools
Longfellow Community Center Remodeling
Hazel Park, Michigan

AFFIDAVIT OF BIDDER #1

The undersigned, the owner or authorized officer of The Summit Company, Inc (the "Bidder"), pursuant to the familial disclosure requirement provided in advertisement for construction bids and Instructions to Bidders, hereby represent and warrant, except as provided below, that no familial relationships exist between the owner(s) or any employee of and any other member of the Board of Education or Administration of **Hazel Park Schools**, or the Superintendent of **Hazel Park Schools**.

List any Familial Relationships:

BIDDER: The Summit Company, INC
By: Anthony Dattilo Tony Dattilo
Its: President

STATE OF MICHIGAN)
COUNTY OF Wayne)ss

This instrument was acknowledged before me on the 22nd day of October, in the year 2024, by Sara King.

Sara King
Notary Public
Wayne County, Michigan



My Commission Expires: 11/17/29
Acting in the County of: Wayne

Kingscott Associates, Inc.
Architects/Engineers
Portage, Michigan

Hazel Park Schools
Longfellow Community Center Remodeling
Hazel Park, Michigan

AFFIDAVIT OF BIDDER #2

The undersigned, the owner or authorized officer of The Summit Company, Inc.
(the "Bidder"), hereby certify that they are not an Iran-linked business nor on the U.S.
Government Services Administration's Excluded Parties List.

BIDDER: The Summit Company, INC.
By: Anthony Dattilio Tony Dattilio
Its: President

STATE OF MICHIGAN)
)ss
COUNTY OF Wayne)

This instrument was acknowledged before me on the 22nd day of October, in the year
2024, by Sara King

Sara King
Wayne, Notary Public
County, Michigan

Sara King
Notary Public State of Michigan
Wayne County
My Commission Expires 11/17/2029
Acting in the County of Wayne

My Commission Expires: 11/17/29

Acting in the County of: Wayne

AIA[®] Document A310[™] – 2010

Bid Bond

CONTRACTOR:

(Name, legal status and address)

The Summit Company Inc
13191 Wayne Road
Livonia, MI 48150

SURETY:

(Name, legal status and principal place of business)

Hudson Insurance Company
100 William Street, 5th Floor
New York, NY 10038

OWNER:

(Name, legal status and address)

Hazel Park Schools
1620 E. Elza Avenue
Hazel Park, MI 48030

BOND AMOUNT: Five Percent (5%) of Amount Bid

This document has important legal consequences. Consultation with an attorney is encouraged with respect to its completion or modification.

Any singular reference to Contractor, Surety, Owner or other party shall be considered plural where applicable.

PROJECT:

(Name, location or address, and Project number, if any)

Longfellow Community Center Remodeling

The Contractor and Surety are bound to the Owner in the amount set forth above, for the payment of which the Contractor and Surety bind themselves, their heirs, executors, administrators, successors and assigns, jointly and severally, as provided herein. The conditions of this Bond are such that if the Owner accepts the bid of the Contractor within the time specified in the bid documents, or within such time period as may be agreed to by the Owner and Contractor, and the Contractor either (1) enters into a contract with the Owner in accordance with the terms of such bid, and gives such bond or bonds as may be specified in the bidding or Contract Documents, with a surety admitted in the jurisdiction of the Project and otherwise acceptable to the Owner, for the faithful performance of such Contract and for the prompt payment of labor and material furnished in the prosecution thereof; or (2) pays to the Owner the difference, not to exceed the amount of this Bond, between the amount specified in said bid and such larger amount for which the Owner may in good faith contract with another party to perform the work covered by said bid, then this obligation shall be null and void, otherwise to remain in full force and effect. The Surety hereby waives any notice of an agreement between the Owner and Contractor to extend the time in which the Owner may accept the bid. Waiver of notice by the Surety shall not apply to any extension exceeding sixty (60) days in the aggregate beyond the time for acceptance of bids specified in the bid documents, and the Owner and Contractor shall obtain the Surety's consent for an extension beyond sixty (60) days.

If this Bond is issued in connection with a subcontractor's bid to a Contractor, the term Contractor in this Bond shall be deemed to be Subcontractor and the term Owner shall be deemed to be Contractor.

When this Bond has been furnished to comply with a statutory or other legal requirement in the location of the Project, any provision in this Bond conflicting with said statutory or legal requirement shall be deemed deleted herefrom and provisions conforming to such statutory or other legal requirement shall be deemed incorporated herein. When so furnished, the intent is that this Bond shall be construed as a statutory bond and not as a common law bond.

Signed and sealed this 22nd day of October, 2024

(Witness)

(Witness)

The Summit Company Inc

(Principal)

(Seal)

(Title)

Hudson Insurance Company

(Surety)

(Seal)

(Title)

Susan L Small, Attorney-in-Fact

Init.

Proposed Contractor List**Longfellow Community Center Remodel**

Hazel Park Schools

570 E. Mapledale Ave., Hazel Park, MI 48030

Scope of Work	Contractor	Contact	Phone
General Contracting	The Summit Company	Tony Dattilio	(734) 845-6506
Demolition	The Summit Company		
Carpentry	The Summit Company		
Millwork	Distinctive Interiors		
Roofing	Royal West Roofing		
Doors & Hardware	Architectural Hardware		
Flooring	Carpet Workroom		
Painting	Axtell Service Inc.		
HVAC	TMX Contracting		
Controls	K & S Ventures		
Electrical	TBD - will determine if we are awarded the contract.		

*We prefer you contact Summit regarding project information.

Post Bid Review Form

Project: Hazel Park Community Center Remodeling
A/E #: 4500.070
Date / Time: 10/29/2024 8:00 AM
Bid Package: Full Scope
Attendees: Matt Spisak, Ryan Alm, Amber Klavon, Rebecca Tritt, Reiley, McDonnell

- 1. Base Bid: **\$457,000.00** Include Addenda #s: **1&2**
- 5. Alternates? Yes No
- 6. Voluntary Alternates? Yes No
- 7. Mark up for additional work
 - SELF-PERFORMED **12%**
 - MATERIAL **12%**
 - SUB-CONTRACTOR **12%**
 - LABOR **12%**
- 9. Union Labor? Yes No
- 11. Sales Tax Included? Yes No
- 12. Warranty Included? Yes No
- 13. Permits Included? Yes No
- 14. Cleanup Included? Yes No
- 15. Reviewed expectations for safe / clean behaviors? Yes No
 - Temporary protection required? Yes No
 - Temporary protection included? Yes No
- 16. Temporary heat required? Yes No
 - Temporary heat included? Yes No
- 18. Has contractor visited site? Yes No
- 19. Does Bid contain qualifications or exclusions to scope of work? Yes No
 - Access Controls, allowance included for \$1500 per card reader for two totaling \$3000**
- 20. Were any exceptions to contract terms and conditions noted in Bid? Yes No

PORTAGE
 950 Trade Centre Way, Suite 130
 Portage, MI 49002
 T:800.632.7815

GRAND RAPIDS
 801 Broadway NW, Suite 306
 Grand Rapids, MI 49504
 T: 800.632.7815

CHELSEA
 300 N. Main Street, Suite 204
 Chelsea, MI 48118
 T:800.632.7815

ROYAL OAK
 818 W. Eleven Mile Road
 Royal Oak, MI 48067
 T: 800.632.7815

- 21. Has the contractor reviewed the insurance coverage and limits Yes No
 Can they obtain the specified coverage limits? Yes No
- 22. Does the contractor understand the schedule start and completion dates? Yes No
 Have they included all costs to meet them? Yes No
- 23. Time required for shop drawings and submittals *6-8 weeks*
- 24. Does Bid account for all overtime and shift time necessary to complete work and meet schedule? Yes No
- 25. Contractor's proposed field organization:
Will send a list of subs
Brian Beach PM
Jake Irwin Superintendent
- 26. Contractor's site requirements (i.e. site trailer, parking, etc.):
No site needs, just parking for contractors
- 27. Proposed Major Contractor:
Self-perfrom carpet and demo
Quality Air Systems is mechanical, major
- 28. Does the Contractor have an understanding of the Owner facilities, utilities, power, storage, etc.? Yes No
- 29. Does the Contractor have a safety plan? Yes No
 Name of Safety Representative: *Salvatore Amato*
- 30. Does Contractor have documented procedures for process control (including drawings, submittals, inspection/surveillance, and training)? Yes No

Pro-Core

31. Bid Price Summary

a.	BASE BID	\$457,000.00
b.	Alt A1	\$50,000.00
c.	Alt A2	\$38,000.00
d.	Alt M1	\$250,000.00
	TOTAL	<u>\$795,000.00</u>

PORTAGE
 950 Trade Centre Way, Suite 130
 Portage, MI 49002
 T:800.632.7815

GRAND RAPIDS
 801 Broadway NW, Suite 306
 Grand Rapids, MI 49504
 T: 800.632.7815

CHELSEA
 300 N. Main Street, Suite 204
 Chelsea, MI 48118
 T:800.632.7815

ROYAL OAK
 818 W. Eleven Mile Road
 Royal Oak, MI 48067
 T: 800.632.7815

32. Remarks or comments:

\$1,500 included per card reader for two totaling \$3000
\$22,850 bid bond amount

This conference is in no way intended to indicate the award of a contract.

For: Spartan

Signed: Matthew Spisak

Print Name: Matthew Spisak

Date: 10/31/24

Kingscott Associates, Inc.



Ryan Alm

10/29/2024

PORTAGE

950 Trade Centre Way, Suite 130
Portage, MI 49002
T:800.632.7815

GRAND RAPIDS

801 Broadway NW, Suite 306
Grand Rapids, MI 49504
T: 800.632.7815

CHELSEA

300 N. Main Street, Suite 204
Chelsea, MI 48118
T:800.632.7815

ROYAL OAK

818 W. Eleven Mile Road
Royal Oak, MI 48067
T: 800.632.7815

Kingscott Associates, Inc.
Architects/Engineers
Portage, Michigan

Hazel Park Schools
Longfellow Community Center Remodeling
Hazel Park, Michigan

BID FORM

Owner:
Hazel Park Schools
Hazel Park, Michigan

The undersigned, having carefully examined the Notice to Bidders, Instruction to Bidders, the premise and conditions affecting this work, together with drawings and specifications for the **Hazel Park Schools, Longfellow Community Center Remodeling, Hazel Park, Michigan** and other documents related thereto, does hereby propose to furnish labor, materials, services and equipment necessary to complete all work, called for by and in accordance with the drawings and specifications for same, dated **September 25, 2024** including addenda numbered

1 and 2.

TIME OF COMPLETION

The undersigned agrees to start work upon receipt of the Contract and shall achieve Final Completion by **July 1, 2025**. Construction is to happen beginning **January 1, 2025** with substantial completion on or before **June 1, 2025**. (Note: Contract will be issued after the November 4, 2024 School Board Meeting)

BID SECURITY

Enclosed herewith find (Certified Check), (Cashier's Check), (Bid Bond), in the amount of \$ 5% being 5% percent of the maximum bid herein, made payable to **Hazel Park Schools**. The proceeds of which are to remain the property of the **Hazel Park Schools**, if bidder does not, within ten (10) days after notice of acceptance of bid, enter into a written contract.

EXCEPTIONS AND/OR SUBSTITUTIONS

We have submitted our proposal(s) complete as specified and in accordance with the Construction Documents WITH (WITHOUT) (circle one) exceptions or substitutions. (Explain the exceptions or substitutions below).

BASE BID TOTAL for Hazel Park Schools, Longfellow Community Center, Hazel Park, Michigan

Four hundred and fifty seven thousand Dollars (\$ 457,000.00)

ALTERNATE M1 TOTAL

Additive Deductive

NET CHANGE TO BASE BID TOTAL \$ 50,000.00

Fifty thousand Dollars

ALTERNATE A1 TOTAL

Additive Deductive

NET CHANGE TO BASE BID TOTAL \$ 38,000.00

Thirty eight thousand Dollars

ALTERNATE A2 TOTAL

Additive Deductive

NET CHANGE TO BASE BID TOTAL \$ 250,000.00

Two hundred and fifty thousand Dollars

BID TOTAL (INCLUDING ALL THREE ALTERNATES) for Hazel Park Schools, Longfellow Community Center, Hazel Park, Michigan

Seven hundred and ninety five thousand Dollars (\$ 795,000.00)

ACCEPTANCE:

The undersigned agree(s) to accept a contract for the work covered by this proposal, in accordance with the contract and bidding documents.

The Owner reserves the right to accept or reject any and all proposals or parts of the same.

(CONTINUED)

Kingscott Associates, Inc.
Architects/Engineers
Portage, Michigan

Hazel Park Schools
Longfellow Community Center Remodeling
Hazel Park, Michigan

AFFIDAVIT OF BIDDER #2

The undersigned, the owner or authorized officer of Spartan Construction Group, Inc.
(the "Bidder"), hereby certify that they are not an Iran-linked business nor on the U.S.
Government Services Administration's Excluded Parties List.

BIDDER: Spartan Construction Group, Inc.
By: Matthew Spisak
Matthew Spisak
Its: President

STATE OF MICHIGAN)
COUNTY OF Wayne)ss

This instrument was acknowledged before me on the 22nd day of October, in the year
2024, by Diane L Currie
Diane L Currie

Diane L Currie
, Notary Public
Wayne County, Michigan

DIANE L CURRIE
NOTARY PUBLIC, STATE OF MICHIGAN
COUNTY OF WAYNE
My Commission Expires 12-21-2030
Acting in the County of Wayne

My Commission Expires: 12/21/2030
Acting in the County of: WAYNE

THE AMERICAN INSTITUTE OF ARCHITECTS



AIA Document A310 Bid Bond

KNOW ALL MEN BY THESE PRESENTS, that **WE SPARTAN CONSTRUCTION GROUP, INC. 30956**
Industrial Rd. Livonia, MI 48150

(Here insert full name, and address or legal title of Contractor)

as Principal, hereinafter called the Principal, and **The Ohio Casualty Insurance Company Boston, MA 02116**
a corporation duly organized under the laws of the State of NH as Surety, hereinafter called the Surety, are held and
firmly bound unto **Hazel Park Schools 1620 East Elza Avenue Hazel Park, MI 48030**

(Here insert full name, and address or legal title of Owner)

as Obligee, hereinafter called the Obligee, in the sum of **5.00%** Att Bid

For the payment of which sum well and truly to be made, the said Principal and the said Surety, bind ourselves, our
heirs, executors, administrators, successors and assigns, jointly and severally, firmly by these presents.

WHEREAS, the Principal has submitted a bid for

Hazel Park Schools Longfellow Community Center Remodeling

(Here insert full name, address and description of project)

NOW, THEREFORE, if the Obligee shall accept the bid of the Principal and the Principal shall enter into a Contract
with the Obligee in accordance with the terms of such bid and give such bond or bonds as may be specified in the
bidding or Contract Documents with good and sufficient surety for the faithful performance of such Contract and for
the prompt payment of labor and material furnished in the prosecution thereof, or in the event of the failure of the
Principal to enter such Contract and give such bond or bonds, if the Principal shall pay to the Obligee the difference
not to exceed the penalty hereof between the amount specified in said bid and such larger amount for which the
Obligee may in good faith contract with another party to perform the Work covered by said bid then this obligation
shall be null and void, otherwise to remain in full force and effect.

Signed and sealed this **22nd** day of **October, 2024**

Sal Amato

(Witness)

SPARTAN CONSTRUCTION GROUP, INC.

(Principal)

Matthew Spisak

(Seal)

Officer

The Ohio Casualty Insurance Company

(Surety)

(Seal)

Suzan Giacona
Suzan Giacona, ATTORNEY-IN-FACT

(Witness)

AIA DOCUMENT A310 BID BOND AIA © FEBRUARY 1970 ED THE AMERICAN
INSTITUTE OF ARCHITECTS, 1735 N.Y. AVE., N.W. WASHINGTON, D.C. 20006



This Power of Attorney limits the acts of those named herein, and they have no authority to bind the Company except in the manner and to the extent herein stated.

Liberty Mutual Insurance Company
The Ohio Casualty Insurance Company
West American Insurance Company

Certificate No: 8208616-013058

POWER OF ATTORNEY

KNOWN ALL PERSONS BY THESE PRESENTS: That The Ohio Casualty Insurance Company is a corporation duly organized under the laws of the State of New Hampshire, that Liberty Mutual Insurance Company is a corporation duly organized under the laws of the State of Massachusetts, and West American Insurance Company is a corporation duly organized under the laws of the State of Indiana (herein collectively called the "Companies"), pursuant to and by authority herein set forth, does hereby name, constitute and appoint, Alexandra Johnson, John W. McNish, Lois C. Brink, Michelle B. Graham, Suzan Giacona, Suzanne M. Mocerri

all of the city of Royal Oak state of MI each individually if there be more than one named, its true and lawful attorney-in-fact to make, execute, seal, acknowledge and deliver, for and on its behalf as surety and as its act and deed, any and all undertakings, bonds, recognizances and other surety obligations, in pursuance of these presents and shall be as binding upon the Companies as if they have been duly signed by the president and attested by the secretary of the Companies in their own proper persons.

IN WITNESS WHEREOF, this Power of Attorney has been subscribed by an authorized officer or official of the Companies and the corporate seals of the Companies have been affixed thereto this 19th day of August, 2022.



Liberty Mutual Insurance Company
The Ohio Casualty Insurance Company
West American Insurance Company

By: [Signature]
David M. Carey, Assistant Secretary

State of PENNSYLVANIA ss
County of MONTGOMERY

On this 19th day of August, 2022 before me personally appeared David M. Carey, who acknowledged himself to be the Assistant Secretary of Liberty Mutual Insurance Company, The Ohio Casualty Company, and West American Insurance Company, and that he, as such, being authorized so to do, execute the foregoing instrument for the purposes therein contained by signing on behalf of the corporations by himself as a duly authorized officer.

IN WITNESS WHEREOF, I have hereunto subscribed my name and affixed my notarial seal at Plymouth Meeting, Pennsylvania, on the day and year first above written.



Commonwealth of Pennsylvania - Notary Seal
Teresa Pastella, Notary Public
Montgomery County
My commission expires March 28, 2025
Commission number 1126044
Member, Pennsylvania Association of Notaries

By: [Signature]
Teresa Pastella, Notary Public

This Power of Attorney is made and executed pursuant to and by authority of the following By-laws and Authorizations of The Ohio Casualty Insurance Company, Liberty Mutual Insurance Company, and West American Insurance Company which resolutions are now in full force and effect reading as follows:

ARTICLE IV - OFFICERS: Section 12. Power of Attorney.

Any officer or other official of the Corporation authorized for that purpose in writing by the Chairman or the President, and subject to such limitation as the Chairman or the President may prescribe, shall appoint such attorneys-in-fact, as may be necessary to act in behalf of the Corporation to make, execute, seal, acknowledge and deliver as surety any and all undertakings, bonds, recognizances and other surety obligations. Such attorneys-in-fact, subject to the limitations set forth in their respective powers of attorney, shall have full power to bind the Corporation by their signature and execution of any such instruments and to attach thereto the seal of the Corporation. When so executed, such instruments shall be as binding as if signed by the President and attested to by the Secretary. Any power or authority granted to any representative or attorney-in-fact under the provisions of this article may be revoked at any time by the Board, the Chairman, the President or by the officer or officers granting such power or authority.

ARTICLE XIII - Execution of Contracts: Section 5. Surety Bonds and Undertakings.

Any officer of the Company authorized for that purpose in writing by the chairman or the president, and subject to such limitations as the chairman or the president may prescribe, shall appoint such attorneys-in-fact, as may be necessary to act in behalf of the Company to make, execute, seal, acknowledge and deliver as surety any and all undertakings, bonds, recognizances and other surety obligations. Such attorneys-in-fact subject to the limitations set forth in their respective powers of attorney, shall have full power to bind the Company by their signature and execution of any such instruments and to attach thereto the seal of the Company. When so executed such instruments shall be as binding as if signed by the president and attested by the secretary.

Certificate of Designation - The President of the Company, acting pursuant to the Bylaws of the Company, authorizes David M. Carey, Assistant Secretary to appoint such attorneys-in-fact as may be necessary to act on behalf of the Company to make, execute, seal, acknowledge and deliver as surety any and all undertakings, bonds, recognizances and other surety obligations.

Authorization - By unanimous consent of the Company's Board of Directors, the Company consents that facsimile or mechanically reproduced signature of any assistant secretary of the Company, wherever appearing upon a certified copy of any power of attorney issued by the Company in connection with surety bonds, shall be valid and binding upon the Company with the same force and effect as though manually affixed.

I, Renee C. Llewellyn, the undersigned, Assistant Secretary, The Ohio Casualty Insurance Company, Liberty Mutual Insurance Company, and West American Insurance Company do hereby certify that the original power of attorney of which the foregoing is a full, true and correct copy of the Power of Attorney executed by said Companies, is in full force and effect and has not been revoked.

IN TESTIMONY WHEREOF, I have hereunto set my hand and affixed the seals of said Companies this 22nd day of October, 2024.



By: [Signature]
Renee C. Llewellyn, Assistant Secretary

Not valid for mortgage, note, loan, letter of credit, currency rate, interest rate or residual value guarantees.

For bond and/or Power of Attorney (POA) verification inquiries, please call 610-832-8240 or email HOSUR@libertymutual.com.



October 29th, 2024

Hazel Park Schools Longfellow Community Center

List Of Subcontractors

Scope Of Work	Contractor
Selective Demolition	Self Perform
Carpentry	Self Perform
Roofing	Esko Roofing
Doors/ Frames/ Hardware	A&C Builders Hardware
Glazing	Glasco
Millwork	Distinctive Millwork
Flooring	Trist Creek Flooring
Painting	Trio Painting
Mechanical	Quality Aire Systems
Electrical	CC Electrical

November 7, 2024

Hazel Park Schools
1620 E. Elza
Hazel Park, MI 48030
Attention: Amy Kruppe
Re: Longfellow Community Center Remodeling Project
A/E # 04500.07

Dear Dr. Kruppe,

On Tuesday, October 22, 2024, at 2:00 PM local time, bids were taken for the Longfellow Community Center Remodeling work. Two valid bids were submitted at \$457,000 and \$544,700, not including the bid alternates. There were three bid alternates listed for various work scope; these are listed below.

There was a third bid submitted for \$78,359, but this bid has since been withdrawn due to an error by the contractor. As this bid has been withdrawn, it is excluded from this document.

The lower of the two bids was from Spartan Construction Group, Inc. at \$457,000 for the base bid amount. Based on the post-bid interview, it appears that Spartan Construction Group, Inc. has satisfied the requirements of the bid documents. Spartan Construction Group, Inc. has completed previous work for Hazel Park Schools in recent years.

In addition to the base bid, the project also included three bid alternates. The descriptions are as follows:

Alternate M-1 – Installation of two additional mechanical units to supply cooling to two additional rooms as indicated on drawings. Spartan Construction Group, Inc. submitted a bid for alternate M-1 at \$50,000.00. Kingscott recommends accepting this additive bid alternate.

Alternate A-1 – Replacement of two sets of vestibule doors and storefront at west entrance including card readers and door operators as indicated on drawings. Spartan Construction Group, Inc. submitted a bid for alternate A-1 at \$38,000.00. Kingscott recommends accepting this additive bid alternate.

Alternate A-2 – Roof replacement at three areas totaling 10,500 square feet as indicated on drawings. Spartan Construction Group, Inc. submitted a bid for alternate A-2 at \$250,000.00. Kingscott recommends accepting this additive bid alternate.



Based on our review of the bid form and on the result of the post-bid interview, Kingscott Associates, Inc. recommends that Hazel Park Schools enter into a contract with Spartan Construction Group, Inc. for the Longfellow Community Center Remodeling project as outlined in the plans and specifications prepared by Kingscott Associates, Inc. dated September 25, 2024, including Addendum 1 and 2, for the base bid project in the amount of \$457,000 (including the performance bond). Kingscott also recommends acceptance of Alternate M-1 in the amount of \$50,000.00, A-1 in the amount of \$38,000.00, A-2 in the amount of \$250,000.00. The total award amount is \$795,000.00.

Along with this letter of recommendation, we have included the bid tab results and the bid forms from both bidders. If you have any questions or concerns, please feel free to contact me.

Sincerely,

KINGSCOTT

A handwritten signature in black ink, appearing to read 'Ryan Alm'.

Ryan Alm, AIA
Project Manager

KALAMAZOO
259 E. Michigan Ave., Suite 308
Kalamazoo, MI 49007
T: 800.632.7815

GRAND RAPIDS
801 Broadway NW, Suite 306
Grand Rapids, MI 49504
T: 800.632.7815

59

CHELSEA
300 N. Main Street, Suite 204
Chelsea, MI 48118
T: 800.632.7815

ROYAL OAK
818 W. Eleven Mile Road
Royal Oak, MI 48067
T: 800.632.7815

Company	Base Bid	Alternate M-1	Alternate A-1	Alternate A-2	Total Bid	Addenda	Forms
Allied	\$78,359.00	-	\$7,600.00	-	-	1	Yes
Spartan	\$457,000.00	\$50,000.00	\$38,000.00	\$250,000.00	\$795,000.00	1 & 2	Yes
Summit	\$544,700.00	\$34,375.00	\$44,900.00	\$249,000.00	\$872,975.00	1	Yes

Kingscott Associates, Inc.
Architects/Engineers
Portage, Michigan

Hazel Park Schools
Longfellow Community Center Remodeling
Hazel Park, Michigan

BID FORM

Owner:
Hazel Park Schools
Hazel Park, Michigan

The undersigned, having carefully examined the Notice to Bidders, Instruction to Bidders, the premise and conditions affecting this work, together with drawings and specifications for the **Hazel Park Schools, Longfellow Community Center Remodeling, Hazel Park, Michigan** and other documents related thereto, does hereby propose to furnish labor, materials, services and equipment necessary to complete all work, called for by and in accordance with the drawings and specifications for same, dated **September 25, 2024** including addenda numbered

1 and 2.

TIME OF COMPLETION

The undersigned agrees to start work upon receipt of the Contract and shall achieve Final Completion by **July 1, 2025**. Construction is to happen beginning **January 1, 2025** with substantial completion on or before **June 1, 2025**. (Note: Contract will be issued after the November 4, 2024 School Board Meeting)

BID SECURITY

Enclosed herewith find (Certified Check), (Cashier's Check), (Bid Bond), in the amount of \$ 5% being 5% percent of the maximum bid herein, made payable to **Hazel Park Schools**. The proceeds of which are to remain the property of the **Hazel Park Schools**, if bidder does not, within ten (10) days after notice of acceptance of bid, enter into a written contract.

EXCEPTIONS AND/OR SUBSTITUTIONS

We have submitted our proposal(s) complete as specified and in accordance with the Construction Documents WITH (WITHOUT) (circle one) exceptions or substitutions. (Explain the exceptions or substitutions below).

BASE BID TOTAL for Hazel Park Schools, Longfellow Community Center, Hazel Park, Michigan

Four hundred and fifty seven thousand Dollars (\$ 457,000.00)

ALTERNATE M1 TOTAL

Additive Deductive

NET CHANGE TO BASE BID TOTAL \$ 50,000.00
Fifty thousand Dollars

ALTERNATE A1 TOTAL

Additive Deductive

NET CHANGE TO BASE BID TOTAL \$ 38,000.00
Thirty eight thousand Dollars

ALTERNATE A2 TOTAL

Additive Deductive

NET CHANGE TO BASE BID TOTAL \$ 250,000.00
Two hundred and fifty thousand Dollars

BID TOTAL (INCLUDING ALL THREE ALTERNATES) for Hazel Park Schools, Longfellow Community Center, Hazel Park, Michigan

Seven hundred and ninety five thousand Dollars (\$ 795,000.00)

ACCEPTANCE:

The undersigned agree(s) to accept a contract for the work covered by this proposal, in accordance with the contract and bidding documents.

The Owner reserves the right to accept or reject any and all proposals or parts of the same.

(CONTINUED)

Kingscott Associates, Inc.
Architects/Engineers
Portage, Michigan

Hazel Park Schools
Longfellow Community Center Remodeling
Hazel Park, Michigan

AFFIDAVIT OF BIDDER #1

The undersigned, the owner or authorized officer of Spartan Construction Group Inc. (the "Bidder"), pursuant to the familial disclosure requirement provided in advertisement for construction bids and Instructions to Bidders, hereby represent and warrant, except as provided below, that no familial relationships exist between the owner(s) or any employee of and any other member of the Board of Education or Administration of **Hazel Park Schools**, or the Superintendent of **Hazel Park Schools**.

List any Familial Relationships:

BIDDER: Spartan Construction Group Inc.

By: Matthew Spisak
Matthew Spisak

Its: President

STATE OF MICHIGAN)
)ss
COUNTY OF WAYNE)

This instrument was acknowledged before me on the 22nd day of October, in the year 2024, by Diane L Currie
Diane L Currie

Diane L Currie
, Notary Public
WAYNE County, Michigan

DIANE L CURRIE
NOTARY PUBLIC, STATE OF MICHIGAN
COUNTY OF WAYNE
My Commission Expires 12-21-2030
Acting in the County of WAYNE

My Commission Expires: 12/21/2030

Acting in the County of: WAYNE

THE AMERICAN INSTITUTE OF ARCHITECTS



AIA Document A310 Bid Bond

KNOW ALL MEN BY THESE PRESENTS, that **WE SPARTAN CONSTRUCTION GROUP, INC. 30956**
Industrial Rd. Livonia, MI 48150

(Here insert full name, and address or legal title of Contractor)

as Principal, hereinafter called the Principal, and **The Ohio Casualty Insurance Company Boston, MA 02116**
a corporation duly organized under the laws of the State of NH as Surety, hereinafter called the Surety, are held and
firmly bound unto **Hazel Park Schools 1620 East Elza Avenue Hazel Park, MI 48030**

(Here insert full name, and address or legal title of Owner)

as Obligee, hereinafter called the Obligee, in the sum of **5.00%** Att Bid

For the payment of which sum well and truly to be made, the said Principal and the said Surety, bind ourselves, our
heirs, executors, administrators, successors and assigns, jointly and severally, firmly by these presents.

WHEREAS, the Principal has submitted a bid for

Hazel Park Schools Longfellow Community Center Remodeling

(Here insert full name, address and description of project)

NOW, THEREFORE, if the Obligee shall accept the bid of the Principal and the Principal shall enter into a Contract
with the Obligee in accordance with the terms of such bid and give such bond or bonds as may be specified in the
bidding or Contract Documents with good and sufficient surety for the faithful performance of such Contract and for
the prompt payment of labor and material furnished in the prosecution thereof, or in the event of the failure of the
Principal to enter such Contract and give such bond or bonds, if the Principal shall pay to the Obligee the difference
not to exceed the penalty hereof between the amount specified in said bid and such larger amount for which the
Obligee may in good faith contract with another party to perform the Work covered by said bid then this obligation
shall be null and void, otherwise to remain in full force and effect.

Signed and sealed this **22nd** day of **October, 2024**

Sal Amato

SPARTAN CONSTRUCTION GROUP, INC.

(Principal) *Matthew Spisak* (Seal)

(Witness)

Officer

Alexander Johnson

The Ohio Casualty Insurance Company
(Surety) *Suzan Giacona* (Seal)

(Witness)

Suzan Giacona, ATTORNEY-IN-FACT

AIA DOCUMENT A310 BID BOND AIA © FEBRUARY 1970 ED THE AMERICAN
INSTITUTE OF ARCHITECTS, 1735 N.Y. AVE., N.W. WASHINGTON, D.C. 20006



This Power of Attorney limits the acts of those named herein, and they have no authority to bind the Company except in the manner and to the extent herein stated.

Liberty Mutual Insurance Company
The Ohio Casualty Insurance Company
West American Insurance Company

Certificate No: 8208616-013058

POWER OF ATTORNEY

KNOWN ALL PERSONS BY THESE PRESENTS: That The Ohio Casualty Insurance Company is a corporation duly organized under the laws of the State of New Hampshire, that Liberty Mutual Insurance Company is a corporation duly organized under the laws of the State of Massachusetts, and West American Insurance Company is a corporation duly organized under the laws of the State of Indiana (herein collectively called the "Companies"), pursuant to and by authority herein set forth, does hereby name, constitute and appoint, Alexandra Johnson, John W. McNish, Lois C. Brink, Michelle B. Graham, Suzan Giacona, Suzanne M. Mocerri

all of the city of Royal Oak state of MI each individually if there be more than one named, its true and lawful attorney-in-fact to make, execute, seal, acknowledge and deliver, for and on its behalf as surety and as its act and deed, any and all undertakings, bonds, recognizances and other surety obligations, in pursuance of these presents and shall be as binding upon the Companies as if they have been duly signed by the president and attested by the secretary of the Companies in their own proper persons.

IN WITNESS WHEREOF, this Power of Attorney has been subscribed by an authorized officer or official of the Companies and the corporate seals of the Companies have been affixed thereto this 19th day of August, 2022.



Liberty Mutual Insurance Company
The Ohio Casualty Insurance Company
West American Insurance Company

By: [Signature]
David M. Carey, Assistant Secretary

State of PENNSYLVANIA ss
County of MONTGOMERY

On this 19th day of August, 2022 before me personally appeared David M. Carey, who acknowledged himself to be the Assistant Secretary of Liberty Mutual Insurance Company, The Ohio Casualty Company, and West American Insurance Company, and that he, as such, being authorized so to do, execute the foregoing instrument for the purposes therein contained by signing on behalf of the corporations by himself as a duly authorized officer.

IN WITNESS WHEREOF, I have hereunto subscribed my name and affixed my notarial seal at Plymouth Meeting, Pennsylvania, on the day and year first above written.



Commonwealth of Pennsylvania - Notary Seal
Teresa Pastella, Notary Public
Montgomery County
My commission expires March 28, 2025
Commission number 1126044
Member, Pennsylvania Association of Notaries

By: [Signature]
Teresa Pastella, Notary Public

This Power of Attorney is made and executed pursuant to and by authority of the following By-laws and Authorizations of The Ohio Casualty Insurance Company, Liberty Mutual Insurance Company, and West American Insurance Company which resolutions are now in full force and effect reading as follows:

ARTICLE IV - OFFICERS: Section 12. Power of Attorney.

Any officer or other official of the Corporation authorized for that purpose in writing by the Chairman or the President, and subject to such limitation as the Chairman or the President may prescribe, shall appoint such attorneys-in-fact, as may be necessary to act in behalf of the Corporation to make, execute, seal, acknowledge and deliver as surety any and all undertakings, bonds, recognizances and other surety obligations. Such attorneys-in-fact, subject to the limitations set forth in their respective powers of attorney, shall have full power to bind the Corporation by their signature and execution of any such instruments and to attach thereto the seal of the Corporation. When so executed, such instruments shall be as binding as if signed by the President and attested to by the Secretary. Any power or authority granted to any representative or attorney-in-fact under the provisions of this article may be revoked at any time by the Board, the Chairman, the President or by the officer or officers granting such power or authority.

ARTICLE XIII - Execution of Contracts: Section 5. Surety Bonds and Undertakings.

Any officer of the Company authorized for that purpose in writing by the chairman or the president, and subject to such limitations as the chairman or the president may prescribe, shall appoint such attorneys-in-fact, as may be necessary to act in behalf of the Company to make, execute, seal, acknowledge and deliver as surety any and all undertakings, bonds, recognizances and other surety obligations. Such attorneys-in-fact subject to the limitations set forth in their respective powers of attorney, shall have full power to bind the Company by their signature and execution of any such instruments and to attach thereto the seal of the Company. When so executed such instruments shall be as binding as if signed by the president and attested by the secretary.

Certificate of Designation - The President of the Company, acting pursuant to the Bylaws of the Company, authorizes David M. Carey, Assistant Secretary to appoint such attorneys-in-fact as may be necessary to act on behalf of the Company to make, execute, seal, acknowledge and deliver as surety any and all undertakings, bonds, recognizances and other surety obligations.

Authorization - By unanimous consent of the Company's Board of Directors, the Company consents that facsimile or mechanically reproduced signature of any assistant secretary of the Company, wherever appearing upon a certified copy of any power of attorney issued by the Company in connection with surety bonds, shall be valid and binding upon the Company with the same force and effect as though manually affixed.

I, Renee C. Llewellyn, the undersigned, Assistant Secretary, The Ohio Casualty Insurance Company, Liberty Mutual Insurance Company, and West American Insurance Company do hereby certify that the original power of attorney of which the foregoing is a full, true and correct copy of the Power of Attorney executed by said Companies, is in full force and effect and has not been revoked.

IN TESTIMONY WHEREOF, I have hereunto set my hand and affixed the seals of said Companies this 22nd day of October, 2024.



By: [Signature]
Renee C. Llewellyn, Assistant Secretary

Not valid for mortgage, note, loan, letter of credit, currency rate, interest rate or residual value guarantees.

For bond and/or Power of Attorney (POA) verification inquiries, please call 610-832-8240 or email HOSUR@libertymutual.com.



Page: 1
Date: 10/22/24
Proposal No.: 24235

PROPOSAL

To: Hazel Park Schools
1620 E. Elza
Hazel Park, MI 48030

Project: Longfellow Community Center Remodel
Location: 570 E. Mapledale Ave., Hazel Park, MI 48030

Attn: Ryan Alm
586-764-0112

Arch/Eng'r: Kingscott Associates, Inc.
Arch/Eng'r Project No.: 4500.07

We propose to provide the following described scope for the sum of..... \$544,700.00

Labor, materials, equipment and supervision to complete the Longfellow Community Center Remodel project per drawings dated 9/25/24, specifications dated 9/25/24 and addendum 1 dated 10/14/24.

- Alternate M1 \$34,375.00
• Alternate 1 \$44,900.00
• Alternate 2 \$249,000.00

Total for all alternates and base bid combined. \$872,975.00

Please Note:

- A)
B)

Proposal price includes ALLOWANCE(S) for:

Permits (e.g. bldg., sewer, water, R.O.W., soil erosion) and related fees (e.g. inspection, tap, assessment, review, surety) of.. \$7,500.00
Public utility charges (including meters) of..... \$0.00

Terms and Conditions

- 1. This proposal is based on:
(a) Price(s) and fee(s) firm for 20 days (see item 1f for exceptions).
(b) AIA Document A201 2007 edition General Conditions (unless stated otherwise in bid documents).
(c) Construction performed during regular work hours (except minor tie-in work or specifically stated in proposal).
(d) Payment terms net 30 days after our invoice is submitted.
(e) Owner promptly providing to us a recorded Notice of Commencement and copies of all Notices of Furnishings and/or requests for Notices of Commencement.
(f) CPI not increasing more than 1% and/or material/energy prices not increasing from date of this proposal.
2. This proposal excludes:
(a) Building and site conditions such as dewatering, unstable ground, interferences (e.g. utilities, rock, concrete, conduits), locating utility lines or other problematic conditions.
(b) Recognition, testing and/or removal of contaminated or hazardous gases/materials, including asbestos and lead (proposal assumes the owner will provide written notification to us if there are any contaminated or hazardous gases/materials, including asbestos and lead, on the premises with specific location(s) before construction begins).
(c) Winter conditions and associated costs.
(d) Liability in excess of our insurance coverage (proposal assumes property insurance by owner).
(e) General conditions and supervision costs for scope changes and owner/architect caused delays.
(f) Liability for any loss, damage or delay caused by acts beyond our control including acts of God, weather, failure of supplier/mfr. to perform and labor disputes.
(g) 3rd party inspections/testing and SWPPP for stormwater.

This proposal shall be the contract agreement or this proposal shall be part of a separate owner/contractor agreement.

Purchaser: _____

The Summit Company, Inc.

Sign/Date: _____

Keith Norush (handwritten signature)

Keith Norush

Kingscott Associates, Inc.
Architects/Engineers
Portage, Michigan

Hazel Park Schools
Longfellow Community Center Remodeling
Hazel Park, Michigan

BID FORM

Owner:
Hazel Park Schools
Hazel Park, Michigan

The undersigned, having carefully examined the Notice to Bidders, Instruction to Bidders, the premise and conditions affecting this work, together with drawings and specifications for the **Hazel Park Schools, Longfellow Community Center Remodeling, Hazel Park, Michigan** and other documents related thereto, does hereby propose to furnish labor, materials, services and equipment necessary to complete all work, called for by and in accordance with the drawings and specifications for same, dated **September 25, 2024** including addenda numbered

#1 Dated 10/14/24.

TIME OF COMPLETION

The undersigned agrees to start work upon receipt of the Contract and shall achieve Final Completion by **July 1, 2025**. Construction is to happen beginning **January 1, 2025** with substantial completion on or before **June 1, 2025**. (Note: Contract will be issued after the November 4, 2024 School Board Meeting)

BID SECURITY

Enclosed herewith find (Certified Check), (Cashier's Check), (Bid Bond), in the amount of \$ _____ being 5% percent of the maximum bid herein, made payable to **Hazel Park Schools**. The proceeds of which are to remain the property of the **Hazel Park Schools**, if bidder does not, within ten (10) days after notice of acceptance of bid, enter into a written contract.

EXCEPTIONS AND/OR SUBSTITUTIONS

We have submitted our proposal(s) complete as specified and in accordance with the Construction Documents WITH/WITHOUT (circle one) exceptions or substitutions. (Explain the exceptions or substitutions below).

BASE BID TOTAL for Hazel Park Schools, Longfellow Community Center, Hazel Park, Michigan

Five hundred forty-four thousand seven hundred Dollars (\$ 544,700)

ALTERNATE M1 TOTAL

Additive Deductive

NET CHANGE TO BASE BID TOTAL \$ 34,375
Thirty-four thousand three hundred seventy-five Dollars

ALTERNATE A1 TOTAL

Additive Deductive

NET CHANGE TO BASE BID TOTAL \$ 44,900
Forty-four thousand nine hundred Dollars

ALTERNATE A2 TOTAL

Additive Deductive

NET CHANGE TO BASE BID TOTAL \$ 249,000
Two hundred forty-nine thousand Dollars

BID TOTAL (INCLUDING ALL THREE ALTERANTES) for Hazel Park Schools, Longfellow Community Center, Hazel Park, Michigan

Eight hundred seventy-two thousand nine hundred seventy-five Dollars (\$ 872,975)

ACCEPTANCE:

The undersigned agree(s) to accept a contract for the work covered by this proposal, in accordance with the contract and bidding documents.

The Owner reserves the right to accept or reject any and all proposals or parts of the same.

(CONTINUED)

BIDDER STATUS:

(Check One)

 Individual Partnership Corporation

Submitted By:
Company

The Summit Company, Inc.

Address

13191 Wayne Rd., Livonia, MI 48150

Telephone/Fax

734-261-3500

Email

Tdattilio@summitcompany.net

Signature/Date

Tony M. Dattilio 10/22/24

Print Name/Title

Tony Dattilio, President

SCHEDULE

The proposed schedule may be a deciding factor in the selection of the successful bidder. Please indicate the proposed schedule as follows:

Proposed Material Delivery Date: Jan 31, 2025

Proposed Installation Start Date: Feb 1, 2025

Proposed Completion Date: May, 2025

END OF SECTION

Kingscott Associates, Inc.
Architects/Engineers
Portage, Michigan

Hazel Park Schools
Longfellow Community Center Remodeling
Hazel Park, Michigan

AFFIDAVIT OF BIDDER #1

The undersigned, the owner or authorized officer of The Summit Company, Inc (the "Bidder"), pursuant to the familial disclosure requirement provided in advertisement for construction bids and Instructions to Bidders, hereby represent and warrant, except as provided below, that no familial relationships exist between the owner(s) or any employee of and any other member of the Board of Education or Administration of **Hazel Park Schools**, or the Superintendent of **Hazel Park Schools**.

List any Familial Relationships:

BIDDER: The Summit Company, INC
By: Anthony Dattilo Tony Dattilo
Its: President

STATE OF MICHIGAN)
COUNTY OF Wayne)ss

This instrument was acknowledged before me on the 22nd day of October, in the year 2024, by Sara King.

Sara King
Notary Public
Wayne County, Michigan



My Commission Expires: 11/17/29
Acting in the County of: Wayne

Kingscott Associates, Inc.
Architects/Engineers
Portage, Michigan

Hazel Park Schools
Longfellow Community Center Remodeling
Hazel Park, Michigan

AFFIDAVIT OF BIDDER #2

The undersigned, the owner or authorized officer of The Summit Company, Inc.
(the "Bidder"), hereby certify that they are not an Iran-linked business nor on the U.S.
Government Services Administration's Excluded Parties List.

BIDDER: The Summit Company, INC.
By: Anthony Dattilio Tony Dattilio
Its: President

STATE OF MICHIGAN)
)ss
COUNTY OF Wayne)

This instrument was acknowledged before me on the 22nd day of October, in the year
2024, by Sara King

Sara King
Wayne, Notary Public
County, Michigan

Sara King
Notary Public State of Michigan
Wayne County
My Commission Expires 11/17/2029
Acting in the County of Wayne

My Commission Expires: 11/17/29

Acting in the County of: Wayne

AIA[®] Document A310[™] – 2010

Bid Bond

CONTRACTOR:

(Name, legal status and address)

The Summit Company Inc
13191 Wayne Road
Livonia, MI 48150

SURETY:

(Name, legal status and principal place of business)

Hudson Insurance Company
100 William Street, 5th Floor
New York, NY 10038

OWNER:

(Name, legal status and address)

Hazel Park Schools
1620 E. Elza Avenue
Hazel Park, MI 48030

BOND AMOUNT: Five Percent (5%) of Amount Bid

This document has important legal consequences. Consultation with an attorney is encouraged with respect to its completion or modification.

Any singular reference to Contractor, Surety, Owner or other party shall be considered plural where applicable.

PROJECT:

(Name, location or address, and Project number, if any)

Longfellow Community Center Remodeling

The Contractor and Surety are bound to the Owner in the amount set forth above, for the payment of which the Contractor and Surety bind themselves, their heirs, executors, administrators, successors and assigns, jointly and severally, as provided herein. The conditions of this Bond are such that if the Owner accepts the bid of the Contractor within the time specified in the bid documents, or within such time period as may be agreed to by the Owner and Contractor, and the Contractor either (1) enters into a contract with the Owner in accordance with the terms of such bid, and gives such bond or bonds as may be specified in the bidding or Contract Documents, with a surety admitted in the jurisdiction of the Project and otherwise acceptable to the Owner, for the faithful performance of such Contract and for the prompt payment of labor and material furnished in the prosecution thereof; or (2) pays to the Owner the difference, not to exceed the amount of this Bond, between the amount specified in said bid and such larger amount for which the Owner may in good faith contract with another party to perform the work covered by said bid, then this obligation shall be null and void, otherwise to remain in full force and effect. The Surety hereby waives any notice of an agreement between the Owner and Contractor to extend the time in which the Owner may accept the bid. Waiver of notice by the Surety shall not apply to any extension exceeding sixty (60) days in the aggregate beyond the time for acceptance of bids specified in the bid documents, and the Owner and Contractor shall obtain the Surety's consent for an extension beyond sixty (60) days.

If this Bond is issued in connection with a subcontractor's bid to a Contractor, the term Contractor in this Bond shall be deemed to be Subcontractor and the term Owner shall be deemed to be Contractor.

When this Bond has been furnished to comply with a statutory or other legal requirement in the location of the Project, any provision in this Bond conflicting with said statutory or legal requirement shall be deemed deleted herefrom and provisions conforming to such statutory or other legal requirement shall be deemed incorporated herein. When so furnished, the intent is that this Bond shall be construed as a statutory bond and not as a common law bond.

Signed and sealed this 22nd day of October, 2024

(Witness)

(Witness)

The Summit Company Inc

(Principal)

(Seal)

(Title)

Hudson Insurance Company

(Surety)

(Seal)

(Title)

Susan L Small, Attorney-in-Fact

Init.

AIA Document A310[™] – 2010. Copyright © 1963, 1970 and 2010 by The American Institute of Architects. All rights reserved. WARNING: This AIA[®] Document is protected by U.S. Copyright Law and International Treaties. Unauthorized reproduction or distribution of this AIA[®] Document, or any portion of it, may result in severe civil and criminal penalties, and will be prosecuted to the maximum extent possible under the law. This document was created on 01/27/2012 07:23:12 under the terms of AIA Documents-on-Demand[™] order no. 2008397483, and is not for resale. This document is licensed by The American Institute of Architects for one-time use only, and may not be reproduced prior to its completion. 061110

e. City Hazel Park State MI Zip 48030-2358
 f. Federal ID Number 38-6003088 DUNS Number 039866926 Unique Entity Id. WUTWHMJLM
 7L5

g. Agency Type

- Consortium of local governments
- Faith-based (providing nonreligious services to public)
- Local unit of government (tribal, county, city, village, or township)
- 501 (c) 3 Private, Non-Profit
- 501 (c) 19, Non-Profit Organization
- Public
- Regional/statewide organization
- School
- College or University
- Other

Project Information

a. Project Name MI Community Center Grant - 2024

b. Is implementing agency same As Applicant Yes No

c. Implementing Agency Name

d. Project Start Date Oct-01-2023 End Date Jun-30-2026

e. Amount of Funds Requested \$1,000,000.00 Project Cost \$1,020,000.00

City Hazel Park State MI Zip 48030-2358
Telephone (248) 658-5225 Fax
E-mail Address james.paterson@myhpsd.org

b. Primary Grant Contact

Name Amy Kruppe
Title Superintendent
Mailing Address 1620 E. Elza
City Hazel Park State MI Zip 48030-2358
Telephone (224) 629-6435 Fax
E-mail Address amy.kruppe@myhpsd.org

c. Financial Officer

Name Jason Zirnis
Title Financial Officer
Mailing Address 1620 E. Elza
City Hazel Park State MI Zip 48030-2358
Telephone (810) 434-2081 Fax
E-mail Address jason.zirnis@myhpsd.org

d. Authorized Official

Name Amy Kruppe
Title Superintendent
Mailing Address 1620 E. Elza
City Hazel Park State MI Zip 48030-2358
Telephone (224) 629-6435 Fax
E-mail Address amy.kruppe@myhpsd.org

e. Chief Executive Officer

Oakland

Wayne

2. Michigan House district(s) where Project serves

Select one more more Michigan House district(s) from the list below:

State House District 8

3. Michigan Senate district(s) where Project serves

Select one or more Michigan Senate district(s) from the list below:

State Senate District 3

4. U.S. Congress district(s) where Project serves

Select one or more U.S. Congress district(s) from the list below:

US Congress District 11

the "**MI New Economy**" agenda that set a goal of lifting 100,000 families out of working poverty during the next five years. It also supports the recommendations of the **Michigan Poverty Task Force**, whose goal is to address the disparities that affect Michiganders' abilities to afford necessities such as housing, child care, food, health care and transportation.

The Michigan Department of Labor and Economic Opportunity (LEO) is allocating \$60 million for this grant program for community center projects as described in this application. This funding is supported through the American Rescue Plan Act, Coronavirus State and Local Fiscal Recovery Funds (SLFRF) program, which has the goal to build a strong, resilient, and equitable recovery by making investments that support long-term growth and opportunity. Grants will be provided to Community Centers supporting communities that have been negatively impacted due to the pandemic. LEO will award multiple grants: **Minimum awards - \$150,000, Maximum Awards - \$2,500,000.**

Eligible Applicants

Eligible Applicants – Entities that provide Community Center activities could include, Municipalities, Local government agencies, Consortium of local governments, Nonprofits, Faith-based organizations (providing nonreligious services to public), Schools, Colleges, or Universities. Noneligible Applicants: for-profit entities, hospitals, trade associations, credit unions, insurance trusts, fraternal order.

ELIGIBILITY REQUIREMENTS

A Community Center, for the purpose of this project, is defined as a building or other place in which people may gather to receive support services and to participate in social, educational, recreational, and cultural activities. Centers are typically free and open to the community in which they are located or serve. Community Center grants will provide financial assistance to strengthen Michigan communities by enhancing services that provide education support, workforce training, health services, recreation activities, older adult programming, meeting space, and other community needs. Preference will be given to communities that are below the average median income, according to the most recent federal decennial census and to Centers serving the ALICE population. 78

Eligible and Ineligible Costs

Eligible costs: acquisition of property, planning and design costs – including architectural plans, construction and materials costs, renovation costs, infrastructure to equip facilities as needed, programming, and development.

- Local or State Government
- College or University
- 501 (c) 19, Non-Profit Organization

- School
- Other
- Public

1. **Nonprofit Status** - if your organization is a 501(c)3 Nonprofit, operating in Michigan, it must be certified by the Internal Revenue Service. Recipients are required to provide an IRS letter of determination of nonprofit status.

Please upload an IRS letter of determination of nonprofit status

2. **Criteria Requirements:** Applicant must meet one or both of the following criteria.

Criteria	Response
Serves an eligible community according to guidance from the United States Department of the Treasury for the use of state and local fiscal recovery funds under the American Rescue Plan act of 2021, Public Law 117-2 to promote economic recovery.	<input checked="" type="radio"/> Yes <input type="radio"/> No
Owned or operated by a nonprofit, faith-based organization, government entity impacted or disproportionately impacted by the COVID-19 pandemic. Organization must have a demonstrated partnership with the community in which the community center is or will be located.	<input checked="" type="radio"/> Yes <input type="radio"/> No

3. **Criteria Requirements:** Applicants must meet the following Criteria.

Criteria	Response
Community has been negatively impacted as a result of COVID-19	<input checked="" type="radio"/> Yes <input type="radio"/> No
Community Center services are provided at no cost and are open to the community in which they are located or serve.	<input checked="" type="radio"/> Yes <input type="radio"/> No
Community center is located in a high-need area.	<input checked="" type="radio"/> Yes <input type="radio"/> No

	<ul style="list-style-type: none"> 13. National Honor Society 14. Peer Educators 15. Student Council 16. SAT tutoring 17. Reading Nights 18. Social emotional learning 19. Support psychological counseling 20. Youth Assistance. <p>This List is not exhaustive but it is representative of the breadth of programming available year-round, outside the traditional academic school day in the Hazel Park Schools.</p>	
Access to career or workforce training services	<p>The school district has the Detroit Economic Club's Career Readiness Academy "DECCA", which provides a seven month program involving career mentorship, economics, networking and professional etiquette with four field trips per school year. This program prepares students for professional career along with manufacturing and skilled trades.</p> <p>The Michigan Works! program will have space available for job training and education as needed or desired.</p>	15
Indoor or outdoor spaces publicly accessible for recreational or athletic activities	<ul style="list-style-type: none"> 1. Hazel Park High School 2. Hazel Park Junior High School 3. United Oaks Elementary School 4. Hoover Elementary School 5. Webb Elementary School 6. Ford Administrative building as well as the surrounding playground and fields. 7. Longfellow Elementary School and grounds (currently vacant) - this is the proposed site for the the MI Community Center Grant funding. 	3,000

It is encouraged to blend other funding sources to ensure the success of your program. Make sure that you check any regulations to determine if it is allowed for you to blend federal funding sources. It is allowed for you to receive other ARPA funding for your organization, but it cannot be in support of the same programmatic effort you are proposing with this grant application. Include if you have applied for the MI Nonprofit Relief Grant, the MI Nonprofit Impact Grants, the Blight Elimination, MI SPARK Grant (MI Department of Natural Resources). **In the table below, list funding sources supporting this effort.**

Type	Grant or Program Name - Description	Awarding Entity	Date Awarded	Amount
Private	General Fund	Hazel Park Schools	04/19/2024	20,000.00
		TOTAL		20,000.00

Organizational Capacity

Explain how your organization has the capacity to operate the proposed program. Reviewers will assess the extent to which the applicant demonstrates the organizational background and capacity to manage the grant. This would include staffing, structures, compliance, and accountability systems and data collection. Reviewers will consider the quality of the application's response to the following criteria.

Please provide your responses to the questions in the following pages.

1. Organizational Background

1.a. Organizational Background - Organization History (Max 4,000 characters)

The Hazel Park School District was formed in 1884 under the name of School District Number 8.

We believe:

1. The school district supports the social, emotional, physical, and academic needs of each child in a caring, healthy, and safe environment.
2. All students have the ability to learn.
3. A culture that celebrates diversity and promotes equity.
4. Student achievement and social-emotional learning are at the core of every decision.
5. Students are successful when staff, families and the community are engaged and support learning.
6. Research-based curriculum, aligned with state standards is the foundation for high-quality instruction.
7. Student driven learning environments foster self-efficacy and individual ownership of learning.
8. Student success is fostered and supported through multiple pathways toward graduation.

The Hazel Park Schools have demonstrated a long standing history of meeting the community needs as reflected by the creation of the Hazel Park Youth Assistance program in 1953. The program was created by then Hazel Park School Superintendent Wilfred Webb and then Oakland County Probate Judge Eugene Arthur Moore. This program has been successfully adopted by virtually all of the school districts serving the Oakland County communities. A 1992 longitudinal study conducted by Michigan State University concluded that Youth Assistance had a 90% success rate which met the criteria for a high quality program.

most recently, the District has managed, or currently manage grant programs which include but are not limited to:

1. Title I, Title II, Title III, and Title IV.
2. Oakland County Community Coalition grants.
3. Elementary and Secondary School Relief Fund "ESSER", Title I, Title II and Title III.
4. COPS Secure Our Schools grants.
5. Community Schools grants program with Oakland County.

The district has been managing grants from all levels of government along with private grants for many decades and is very familiar with the rigorous nature of some of the requirements.

1.c. Organizational Background - Grant Management (Max 3,000 characters)

The District will be working with non profit organizations within the city, county and state including Michigan Works, United Way, Easter Seals, Youth Assistance, Hazel Park Community Coalition and Gleaners. There are already existing partnerships with these entities in the areas of psychologists, social workers, family supports and food security. Our Business Office also oversees Community Schools Director that ensures provision of wrap around services and family supports.

As already referenced the District founded and indeed maintains a robust relationship with Youth Assistance to reduce the likelihood of a school to prison pipeline developing. The District was also a decade ahead of the rest of the nation in the provision of educational services for special needs students when it established the Marta Jardon facility in 1966. Federal legislation on this area did not occur until 1976.

Hazel Park is one of the few districts within the State of Michigan that has established a Promise Zone which ensures a college scholarship for students that attend Hazel Park Schools.

83

1.d. Organizational Background - Diversity, Equity, and Inclusion (Max 3,000 characters)

The Hazel Park School District is an open enrollment district within the statutory definition under Michigan law, which means we accept students from all other school districts. As such we have a significant number of students from nearby school districts across Oakland, Wayne and Macomb Counties. The immediately adjacent cities are Detroit

The Detroit Economic Club's Career Readiness Academy provides students and opportunity to be mentored and trained in a wide variety of both professional fields and skilled trades.

The Hazel Park Schools has had the Jardon Vocational Education program for special needs students for over 50 years. This program partners with various employers in the area to develop the workplace skills of its special needs students by allowing them to experience real world employment at various locations. Each program is individually tailored to the students abilities and needs.

Hazel Park Schools have a long history of leading from the front on education and workforce development dating back to the 1950's. The Jardon Vocational program was over a decade ahead of the country in meeting students needs and facilitating what are today considered educational best practices. The District has also provided for the social emotional learning needs of students K through the age of 26 at its Center program located a Edison School. This program educates students from across Oakland County.

2. Staff Roles - Project Team Summary

Describe the staff experience and qualifications to implement the scope of service. In the chart below identify the roles and responsibilities of the staff implementing the project including both grant oversight and monitoring. Indicate if staff is considered key to the successful completion of the work. The Respondent must be able to staff a project team which possesses talent and expertise in the field of the requirements of this RFP. Identify staff leads assigned by name and title. Include experience and any other appropriate information regarding the work team's qualification to implement the scope of services. Indicate which of these individuals is considered key to the successful completion of the work. Resumes of qualifications should be supplied for proposed project personnel.

Staff Name	Title	Project Role - Responsibility	Experience	Key Personne l	Resume
Amy Kruppe	Superintendent	Project Lead	22 years as a School Superintendent that	Yes	Amy Kruppe Resume

The Hazel Park Schools have an entire business office that oversees an annual budget in excess of \$40,000,000. The Director of this office, Jason Zirnis, has been identified in this application and is familiar with the grant oversight process. Additionally, our Superintendent, Dr. Amy Kruppe, has previously worked as a Business Manager in a prior school district. Both of these individuals have a significant amount of experience monitoring grant activities and since our request is for a construction grant that would allow the renovation and modernization of an existing school building, our Facilities and Maintenance staff will also contribute to the monitoring of the grant activities in real time along with potentially providing assistance as needed.

Each grant is monitored monthly or more often as needed, and is specially coded within our Business Plus software system. There are also separate Google Docs that set up have triggers for action and check points to ensure compliance.

The District has decades of individual and institutional experience in dealing with grant monitoring along with oversight and reporting.

3.b. Compliance and Accountability - Oversight (Max 3,000 characters)

The Hazel Park Schools Superintendent and Business Manager have extensive experience in the areas of compliance with the rules and regulations of grant terms and rules. All grants have specific conditions that must be met or the grant itself could be jeopardized. The Hazel Park School District is diligent in their efforts to be good stewards of all monies received, and take very seriously our fiduciary duties. Failing to comply with the terms and conditions attached to any grant would result in squandering precious resources that the community desperately needs.

To that end, Dr. Kruppe and the Assistant Superintendent for the business office, Jason Zirnis both personally evaluate and approve or deny expenditures of grant funds. Changes to any grant expenditures are subjected to further oversight by the elected Hazel Park School Board. Mr. Zirnis has served for spent the last 10 years as a Director of Business in school and has 7 years experience as a Senior Auditor where his duties included auditing school districts, cities, townships and other governmental entities. Mr. Zirnis was also a Senior Accountant for 6 years with the firm Arthur Andersen.

Scope

This policy applies to any fraud, or suspected fraud, involving employees as well as consultants, vendors, contractors, outside agencies doing business with employees of such agencies, and any other parties with a business relationship with the District.

Policy

Fraud and fraudulent activity is strictly prohibited.

Each employee or agent of the District shall be responsible for reporting any observed or suspected fraud or fraudulent activity to the Business Office, the Superintendent or the Board President.

All administrators shall be vigilant for any conduct that may appear to constitute fraud within the areas of their responsibility.

All reporting and investigation shall be done in accordance with the District's Whistleblower's Guideline. (AG 1411).

Fraud – Definitions

Fraud is defined as the intentional, false representation or concealment of a material fact for the purpose of inducing another to act upon his/her injury.

The following are examples of prohibited acts:

1. falsification of any District record with the intent to conceal information to the District's detriment or the individual's advantage, particularly financial records
2. forgery of a check, bank draft, wire transfer or any other District financial document
3. unauthorized alteration of a financial document or account belonging to the District
4. misappropriation of funds, supplies or other assets of the District
5. impropriety in the handling or reporting of money or financial transactions
6. disclosing confidential and proprietary information to outside parties for personal gain (either directly or indirectly)
7. asking for or accepting anything of material value from contractors, vendors or persons providing services or materials to the District, except as provided in gift policies
8. unauthorized destruction, removal, or use of records, furniture, fixtures and/or equipment for personal gain

As a school district the compilation of data is a routine process with which we are very comfortable. The data elements that can be collected would originate with the usage level of the facility itself along with the constituent programs located within. Each of these programs compile data and outcomes for themselves and the Hazel Park School District.

This data can be contrasted with existing metrics on educational achievement, workplace development as measured by employment levels and increased access to programming that previously did not exist. Employment and grade point averages are relatively straight forward to measure, as are increased enrollment in services that are accessed.

Usage levels of each program and the facility will be a baseline, and will assist in determining the benefits provided. For example, the benefit from providing access to a social worker or psychologist is clear. What is less clear is how to measure the future harms that may have been avoided but for the provision of these services. Similar to food security and physical activities, they are difficult to quantify, but most would agree that there are real benefits from these services.

The World Health Organization has recognized that the pandemic created a sense of isolation that would be alleviated by having a free and accessible Community Center that provides a wide array of opportunities for usage.

5. Optional - Include any other information that is believed to be pertinent.

In the June 16, 2022 World Health Organization "WHO" Mental Health Report they stated that "Since the start of the pandemic, mental health service providers have tried to mitigate service disruptions, for example by delivering care via alternative routes when public health and social measures were in place. Community-based initiatives were often faster to adapt, finding innovative ways to provide psychosocial support, including through digital technologies and informal supports."

The WHO also recommended integrating Mental Health and Psychosocial Support (MHPSS) within all aspects of preparedness and response for all public health emergencies. To minimize the mental health consequences of the COVID-19 pandemic WHO also recommended:

- Ensure widespread availability of mental health and psychosocial support, including by scaling up access to self-help and supporting community initiatives.
- Support recovery from COVID-19 by building mental health services for the future.

The COVID-19 pandemic, like other ongoing crises, has made strengthening mental health systems more urgent all over the world.

Cost of care has been known to be a major barrier to health care access and the demographics of this community along with the student population within Hazel Park Schools indicate a significantly lower than average income level that has prevented access to not only health care but also broadband internet and job training.

The population of the City of Hazel Park is 16,000 people, the School District educates 3,000 students and these numbers will not entirely overlap as the Hazel Park School District has % of students that reside out of district.

1.b. Community Need - Describe Community Economic Need

- List the median wage of your community on the chart below and identify if it falls below the average state median income level.
- You may use the information provided by the Michigan Center for Data and Analytics median household income at the city/township level.

Median Household Income in Michigan Townships and Cities Sourced from the 2017-21 American Community Survey and the Median Household Income spreadsheet

The World Health Organization has determined that a great number of people have reported psychological distress and symptoms of depression, anxiety or post traumatic stress. And there have been worrying signs of more widespread suicidal thoughts and behaviours, including among health care workers. Some groups of people have been affected much more than others.

Studies have revealed that households with annual incomes below \$100,000 were disproportionately negatively affected by job or wage losses since the start of the outbreak along with reduced access to meaningful health care, which includes psychological services.

The award of this grant to the Hazel Park Schools would allow the district to convert an existing school building into a dedicated Community Center. The existence of this center would provide the community with a meeting area along with a vast array of programming at no cost to the public. The services that would be housed in the community center would encompass health services, physical activities, workforce development, educational assistance, designated services for senior citizens and green technology development.

The Community Center would greatly assist with the sense of isolation and provide desperately needed services that would help alleviate the negative consequences that Hazel Park experienced as a result of the COVID pandemic. The City of Hazel Park has a median household income of \$53,000, significantly below the State of Michigan median income of \$63,000, along with 9.6% of the population below the age of 65 lacking health insurance.

These statistics reveal that the City of Hazel Park was disproportionately impacted in a wide variety of ways and would greatly benefit from being awarded this grant.

2. Community Demographics and Access

2.a. Community Demographics - Geographic Location

- a. List the geographic location of the proposed project and identify the anticipated or known beneficiaries of the program. Beneficiaries could include different age groups or other known identifiable groups supporting.

	Number of people served	Challenges
All Hazel Park Schools programming which include the entire City of Hazel Park	16,000	16,000
A portion of the City of Ferndale that is within the Hazel Park Schools boundary	2,000	2,000
Baldwin House Senior Living Center	200	200
Hazel Park Schools Students	2,900	2,900
All students of Hazel Park Schools which includes a significant population from Wayne and Macomb Counties	800	600

2.c. Community Demographics - Access to Community Center and its Services

The project site is currently identified as Longfellow School and is currently vacant as a result of declining student populations. It is located within the City of Hazel Park within a quarter mile of a bus stop located on John R. Rd. The bus stop is located on a major artery which connects to another major artery that serves all the adjacent communities that may have students or community members that would be served by this Community Center.

Due to the geographic size of the City of Hazel Park and the small lot sizes of the vast majority of houses within the City of Hazel Park, it is safe to assume approximately 1/4th of the population would be within walking distance or one half mile of the proposed Community Center. A safe estimate would be over 4,000 residents would find the center walkable. All the streets within the community have sidewalks and paved roads. The proposed location also possesses off street parking for all vehicle traffic.

The City of Hazel Park is bordered by Eight Mile Rd to the south along with being at the intersection of I-75 and I-696. It is centrally located with borders on both Wayne and Macomb Counties.

2.d. Community Demographics - Support of Poverty Task Force Goals

This project fits into the Michigan poverty task force goals and recommendations by mitigating the harms that resulted from social isolation and workforce development.

Name	Attachment
The City of Hazel Park	<u>Ed Klobucher Recommendation ltr.pdf</u>
Hazel Park Community Coalition Executive Director Kimberly Hart	<u>Letter of recommendation - Community Center.pdf</u>
Hazel Park Promise Zone	<u>HPPZ Letter of Support .pdf</u>
State Representative Mike McFall	<u>Hazel Park Grant Mike McFall.pdf</u>
The Arc Oakland County	<u>ARC Oakland County Letter of Support.pdf</u>
Baldwin House Senior Living	<u>Baldwin House HP Community Center Support 8.25.23.pdf</u>

While not a requirement for funding, is this project part of a community plan?



Yes



No

3.b. Community Support - Strategies to Welcome Community

The Community Center will be administered, staffed and programmed by the Hazel Park School District which has a diverse population within the schools. The District is an "open enrollment" district which welcomes all students that wish to attend and as a result has a significant population from a variety of communities with a diverse population.

Hazel Park Schools also hosts the Roosevelt Invest Academy which is currently located within an existing Hazel Park Elementary School that was previously Roosevelt Elementary School. This school educates refugees from all over the world, particularly the Middle East. Many of these students are english as a second language "ESL" and often times are 1st generation students within the United States.

91

The Hazel Park School District has embraced a focus on social emotional learning and has adopted best practices in these areas as they relate to access. These best practices would also be included in the administration of the community center.

3.c. Community Support - Project Partner List

	Foundation	and mentoring	
--	------------	---------------	--

Capital Project Grant and Program Grant Narratives

There are two additional sections of the grant application. Determine which sections you need to complete.

- 1. **Capital Project Grant**
 - If you are only requesting Capital Project funds, you only need to fill out the Capital Project Grant Narrative Section. Your request cannot be for more than \$2,500,000.

- 2. **Program Grant**
 - If you are only requesting Program funds, you only need to fill out the Program Grant Narrative Section. Your request cannot be for more than \$2,500,000.

- 3. **Capital Project Grant and Program Grant**
 - If you are selecting to receive both Capital and Program funds, you must fill out both remaining sections. Your request cannot be for more than \$2,500,000.

Select Project Type

- Capital Project Grant
- Program Grant

1. Capital Project Description

1. Capital Project Description - Overview

The Hazel Park Schools have an underutilized school building (Longfellow Elementary School), that is in need of renovations to provide the envisioned services and programs. The existing structure contains a full kitchen, gymnasium, media center, multiple classroom spaces with restrooms and office spaces. The building would require renovation, modernization and revitalization due to the age of the facility and the improvement of existing technology.

The project was developed by the Hazel Park Schools Superintendent Dr. Amy Kruppe, and the City of Hazel Park City Manager Ed Klobucher along with the Oakland County Executives Office and numerous stakeholder groups.

2. Capital Project Description - Community Impact

The goal of the project is to provide a wide variety of programs and services to the community, which include wrap around service and training. The existing structure will be renovated to become a multi use facility that can accomodate physical activities in the gymnasium, training in the classrooms, community meeting spaces, internet access, mental health counseling, health care, job training, food services training, meals for eligible community members, tutoring, mentoring, adult education and workforce training.

This list is not exhaustive however the community will benefit from the increased access to services that would otherwise be unavailable to the community. A number of these services are unavailable to the community as reflected by the most recent census data that reflects a significantly below average income and broadband internet access compounded by a higher than average percentage of the population below the household poverty level.

93

3. Capital Project Description - Programs Offered and Beneficiaries

The Capital Project will serve the entire City of Hazel Park, a portion of the City of Ferndale which is located within

Capital Project Grant Narrative for MI Community Center Grant - 2024
 Agency: Hazel Park School District
 Application: MI Community Center Grant - 2024

and Activities (1)

Capital improvements and project implementation. The objective is to increase community access to programming and services that may otherwise be unavailable through a broad array of programming and services including health care, senior programming, physical activities, workplace training, broadband internet access, public meeting spaces, food preparation and food security programs. The program will be a centralized location of sufficient size to accommodate all the various service providers and wrap-around services at a central location.

	Responsible Staff	From Date	To Date	Expected Outcome
3 Central	Jason Zirnis	04/15/2024	04/29/2024	Solicit at least 3 Bids for Architectural Services in compliance with State and Federal Law.
3 Central	Jason Zirnis	05/03/2024	06/07/2024	Successful completion of architectural plans and drawings. Receipt of at least 3 competitive bids for each individual project needed in compliance with state and federal law.
3 Central	Jason Zirnis	06/17/2024	07/01/2024	Receipt of at least 3 competitive bids for each individual project needed in compliance with state and federal law.
3 Central	Jason Zirnis and existing Hazel Park Staff	07/15/2024	06/30/2025	Completion of all construction projects in a satisfactory manner. Receipt of at least 3 competitive bids for each individual project needed in

Capital Project Grant Narrative for MI Community Center Grant - 2024
Agency: Hazel Park School District
Application: MI Community Center Grant - 2024

					compliance with state and federal law.
--	--	--	--	--	--

Existing programs are spread throughout the district at various locations and the accommodation sizes are not optimal. The square footage limitations within existing facilities. A good example would be the gymnasium within Longfellow, there are no other similarly available spaces within the community that are consistently available to the community at large 40+ hours a week. Physical activities, conditioning and therapy would be available throughout traditional business hours. A remodel of the existing school would also provide for confidential meeting space for all traditional health and mental health screening, treatment and counseling.

In the absence of providing increased square footage through a remodel of Longfellow elementary this type of programming is simply not available in existing facilities that are almost entirely co-located within existing schools and therefore must be prioritized behind the core school functions and restricted to students. Opening an existing school to unfettered access by the public is not possible for logistical reasons and school safety considerations. Today's schools must be ever mindful of school access and their core missions which focus on the students' education.

The three choices are as follows:

1. To renovate the existing building at a cost of \$1,000,000. The City of Hazel Park and its land locked with very little vacant land for development. The renovation would be significantly less expensive since it currently provides over 31,000 sq/ft of usable space with more than 2 dozen parking spaces, a turnaround entry for vehicles, a large playground and direct access to a significant residential area, schools and senior living centers. The current building has already been adapted to provide the services that are expected in today's community centers, especially since an existing school structure synergizes well with the programming expectations.
2. To construct a new building of 31,490 sq/ft, which is the size Longfellow currently provides, would conservatively cost \$500/sq/ft. Therefore the construction alone would be \$15,475,000 not including the property acquisition cost. A comparably sized parcel currently for sale in Hazel Park is 24095 Vance and the seller's price is \$899,000. To construct a new building would greatly exceed \$16,000,000 which is obviously significantly more than the \$1,000,000 grant. 96
3. The final option is to purchase an existing building within Hazel Park and renovate it. A comparable that is currently for sale is 1785 E. Nine Mile Rd. That building is priced at \$675,000 and is only 7274 sq/ft, less than 1/4

2. To construct a new building of 31,490 sq/ft, which is the size Longfellow currently provides, would conservatively cost \$500/sq/ft. Therefore the construction alone would be \$15,475,000 not including the property acquisition cost. A comparably sized parcel currently for sale in Hazel Park is 24095 Vance and the seller's price is \$899,000. To construct a new building would greatly exceed \$16,000,000 which is obviously significantly more than the \$1,000,000 grant.

3. The final option is to purchase an existing building within Hazel Park and renovate it. A comparable that is currently for sale is 1785 E. Nine Mile Rd. That building is priced at \$675,000 and is only 7274 sq/ft, less than 1/4 the size of Longfellow, and it has very limited parking, perhaps 10 or 12 spots. As it is an existing manufacturing or light industrial site, the renovation costs would be prohibitive.

The estimate of cost is based on the current Longfellow building value being assessed and insured at \$10,697,000.

Third, lease an existing property located within the City of Hazel Park. This option is untenable due to cost and availability. The City of Hazel Park is entirely developed and there are very few, if any, buildings of sufficient size that could accomodate the proposed programming. Comparables and lease costs are difficult to project.

The most recent facilities assessment was conducted by TMP Architecture in 2021. At that time the "cost must do", and "cost need to do" was \$2,337,485. The passage of time and current construction market would increase the amount beyond the \$1,000,000 grant, assuming the Hazel Park Schools were fortunate enough to receive the full amount sought.

Since the grant award was \$1,000,000, significantly less than the requested amount, the revised revitalization schedule reflects this limitation. A phased approach will be required beyond the \$1,000,000 limit at this time. Future funding sources will need to be identified.

As a result of the reduced funding a new roof and high efficiency HVAC systems have been removed from the scope of this project. The existing roof is over 30 years old.

	improve aesthetics. This preventative step is also necessary to increase the life expectancy of the structure.	
Paved sidewalk	Create a sidewalk from the existing structure to the Baldwin House Senior Living Center. A gate sized portion of fence would also be removed.	0-10 years
Mechanical Utilities	Improving and expanding all existing mechanical utilities	30-40 years
Electrical Utilities	Increased and improved electrical and low voltage building wide.	30-40 years
Interior - New paint, ceilings and flooring throughout the majority of the facility. Additional casework and materials.	A complete refresh of the interior due to the age of the building. A significant part of the flooring is original to the building construction.	20-30 years

3. Construction, Renovation and Maintenance - Maintain Investment

What mechanisms and resources are in place to maintain this investment?

- General Fund Support Millage Endowment Fund
 Grants Friends Group Dedicated Staffing
 Other

Based upon the existing and planned mechanisms and resources, explain how you will maintain the investment and for how long.

The Hazel Park Schools have a vested interest in maintaining this property, not only for the District and its future, but the entire community and region. This type of investment is necessary to improve outcomes for the public as a whole.

The School District also has existing facilities and maintenance staffing and equipment, as well as a cooperative agreement with the City of Hazel Park. The existing capacity is a fixed cost that this grant will not be responsible for providing. All the maintenance and equipment costs are covered by the

The grant award of \$1,000,000 is insufficient to allow replacement of the existing 30+ year old roof. Future funding sources must be identified to allow a replacement roof installation at this time.

How are you assisting the community with accessing energy efficient resources.

There will be programming within the Community Center that will address energy efficiency resources including assistance with accessing energy efficiency credits. Instruction on the use of residential solar energy and how to obtain Federal tax credits. The installation of solar PV units currently provide a 30% tax credit for units installed between 2022-2032.

The use and implementation of urban farming programming will also be periodically provided along with brochures and documents on demand.

5. Construction, Renovation and Maintenance - Sustainability - Volunteer Support

Volunteer efforts exist at all the constituent groups within the Hazel Park Schools. Volunteers currently serve programs like the United Way, Gleaners, Robotics, mentoring, tutoring, Parent Teacher Association, reading assistance, Girls on the Run organization, Band Boosters, Athletic Boosters and many more organizations.

The number of hours contributed by these groups would conservatively be estimated to be in the hundreds or thousands of hours per year.

New efforts would include using the City's ability to increase awareness along with the Schools efforts to increase awareness and participation. The collaboration with the County and all the constituent programming groups would significantly raise awareness and participation.

3. Clarity of Scope

1. Clarity of Scope - Target Dates

- Provide your target dates for the following project milestones.
- Public input planning and design bidding and contract execution construction Programming and activation.

Activation	construction is completed.
------------	----------------------------

2. Clarity of Scope - Site Development Plan

- Conceptual site development plan is required

Please upload your Conceptual site development plan

Revised Longfellow Model _1_.pdf

3. Clarity of Scope - Licensed Architect

All projects are required by state law (MCL 339.2011) to have a licensed engineer, architect, or landscape architect (prime professional) prepare all plans, specifications and bid documents and verify that all construction has been completed according to acceptable standards.

Do you have a architect, engineer, or landscape architect under contract or on staff for this project? Yes No

- If yes, please provide their name and explain the competitive selection process to retain them.
- If no, explain process for acquiring one.

Identified	Architect, Engineer Name	Address	Process to select
No			Any and all monies spent from the grant monies will be bid competitively and pursuant to state and federal law. We will engage an architect at some point in the near future but before doing so we will be competitively posting it for at least 14 days and soliciting at least 3 different bidders.

4. Clarity of Scope - Environmental Contaminations

Type of Permit	Permitting Agency	Requirements	Status
Initial Consultation and planning	The State of Michigan	Determination of continued school status will determine necessary permitting	pending
Initial Consultation and planning	The City of Hazel Park	Determination of continued school status will determine necessary permitting	pending

If no permits are needed – explain process in making that determination

6. Clarity of Scope - Construction Company

Have you selected a construction company to complete the project? Yes No

- If yes, provide their name and explain the competitive selection process use.
- If no provide the competitive selection process you will use.

Identified	Construction Company Name	Address	Process to select
No			Competitive bid process requiring a minimum of 3 bids and is compliant with state and federal law along with school board policy.

101

7. Clarity of Scope - Construction Plans

Have construction plans and specifications been created? Yes No

If Yes, please upload your construction plans below

--	--

1. Accessibility - Group Feedback

- Select what groups you have received feedback from and upload the associated support documentation. Provide design review(s) of your project.
- Groups could include: Center for Independent Living, Center for Assisted Living, Local or Regional Disability Network, Physical or Recreational Therapist, Individual input, Formal or Group Input

Group	Feedback Received	Supporting Documentation
Center for Independent Living	<input checked="" type="checkbox"/>	Baldwin House HP Community Center Support 8.25.23.pdf
Center for Assisted Living	<input type="checkbox"/>	
Local or Regional Disability Network	<input checked="" type="checkbox"/>	ARC Oakland County Letter of Support.pdf
Physical or Recreational Therapist	<input type="checkbox"/>	
Individual input	<input type="checkbox"/>	
Formal or Group Input	<input type="checkbox"/>	
Other	<input type="checkbox"/>	

Provide design review(s) of your project

The Baldwin House Senior Living Center abuts the proposed community center site that is the subject of this grant. With the removal of 10 feet of existing fencing and the construction of approximately 100 feet of concrete sidewalk, the residents of Baldwin House can access the community center at their convenience without needing transportation. This project would make the center much more accessible and walkable.

2. Accessibility - Unique Features

A sidewalk will be installed connecting the entrance of the Community Center directly to the Senior Living Center that abuts the property. This will include removal of a portion of the fencing along with exterior improvements.

2. Capital Project Budget Narrative

3. Budget Narrative – Demonstrate Cost Effectiveness and Budget Adequacy

Preplanning	Description	Grant Funds	Matching Funds	Attach
Total Preplanning				

Project Permitting, plan design, oversight Cap 25%	Description	Grant Funds	Matching Funds	Attach
Total Project Permitting, plan design, oversight				

Construction	Description	Grant Funds	Matching Funds	Attach
Construction Cost Estimates	Revised Construction Costs	1,000,000.00	20,000.00	Hazel Park Community Center Grant Application Construction Estimates.pdf
Total Construction		1,000,000.00	20,000.00	

Budget Summary for MI Community Center Grant - 2024
 Agency: Hazel Park School District
 Application: MI Community Center Grant - 2024

Totals	Grant Funds	Matching Funds	Narrative
0.00	0.00	0.00	
0.00	0.00	0.00	
0.00	0.00	0.00	
0.00	0.00	0.00	
0.00	0.00	0.00	
1,020,000.00	1,000,000.00	20,000.00	

Certification for MI Community Center Grant - 2024
Agency: Hazel Park School District
Application: MI Community Center Grant - 2024

FOR OFFICIAL USE ONLY:

Version # _____

APP # 230330

I am certifying the information submitted is accurate and represents your organization's request for funding. The information on this application and the attachment hereto are true, complete, and accurate to the best of my knowledge and will not be obligated into third-party contract by Dec. 31, 2024. I understand that if funded, this project will need to be completed by Dec. 31, 2026. If I am not the CEO of my organization, I have uploaded a certification statement from the CEO.

James Paterson

James Paterson

Administrator

04/29/2024

Organization?

Yes No

Certification statement from the CEO

Dr Amy Kruppe Certification .pdf

List Of Attachments for MI Community Center Grant - 2024
 Agency: Hazel Park School District
 Application: MI Community Center Grant - 2024

ONLY:

Version # _____

APP # 230330

File	File Name
Amy Kruppe Resume Current.pdf	670_0_Amy Kruppe Resume Curre
Jason Zirnis Resume.pdf	670_1_Jason Zirnis Resume.pdf
Stephanie_Dulmage - Resume.pdf	670_2_Stephanie_Dulmage - Resu
JAMES PATERSON Resume 8-22-23.pdf	670_3_JAMES PATERSON Resum
Ed Klobucher Recommendation ltr.pdf	982_0_Ed Klobucher Recommendation
Letter of recommendation - Community Center.pdf	982_1_Letter of recommendation -
PPZ Letter of Support .pdf	982_2_HPPZ Letter of Support .pdf
Hazel Park Grant Mike McFall.pdf	982_3_Hazel Park Grant Mike McF
ARC Oakland County Letter of Support.pdf	982_4_ARC Oakland County Letter
Baldwin House HP Community Center Support 8.25.23.pdf	982_5_Baldwin House HP Commu
Revised Longfellow Model _1_.pdf	753_Revised Longfellow Model _1
Needs to School District.pdf	791_1_Needs to School District.pdf
Baldwin House HP Community Center Support 8.25.23.pdf	795_0_Baldwin House HP Commu
ARC Oakland County Letter of Support.pdf	795_2_ARC Oakland County Letter
Hazel Park Community Center Grant Application Construction Estimates.pdf	842_0_Hazel Park Community Cen
Amy Kruppe Certification .pdf	Estimates.pdf 679_Dr Amy Kruppe Certification .

strategic planning to reach goals, generating revenue through cost-saving initiatives, and ensuring all students have the tools necessary to be successful. In search of a superintendent role to dedicate servant leadership to a community and lead all children to academic and personal fulfillment.

Key Accomplishments:

- Achieved a \$100K grant to provide social/emotional support to students.
- Increased AP course offerings from three to 11 to better prepare students for college.
- Removed District from deficit for the first time in 15 years.

EXPERTISE

Staff Development | Business/Operations Management | Human Resources | Intervention Response | Special Education | Community Relations | Diversity & Inclusion | Cost Savings | Revenue Generation | Program Implementation & Management | Interdepartmental Communication | Technology Implementation | Contract Negotiation

CAREER HISTORY

Superintendent

Hazel Park School District | Hazel Park, MI | JULY 2015 – PRESENT

Superintendent of School District of 3,500 students in one of the Promise Zone Schools in the state of Michigan. Oversee all District functions and operations support in the turnaround process during the DEP.

Accomplishments:

- Reduced school deficit from -\$8M to +\$1.6M by utilizing grants and staff more effectively; refinanced two bonds, saving the district over \$7M.
- Wrote a grant for \$120K to provide computers to the community.
- Achieved a \$100K grant for emotional support to students. Received \$30K to move forward with PBIS emotional support for students.
- Increased salaries to become more competitive to attract optimal talent within the school district.
- Improved AP courses from three to 11 to ready students for college, resulting in increased participation.

Implementations/Operations:

- Transitioned in-person schooling to online in the wake of the pandemic; developed K-8 virtual school during/post-pandemic. Provide safe and secure return to school plan based on CDC recommendations.
- Worked with the Midwest Equity Center in Indiana to implement Diversity, Equity, & Inclusion team.
- Supported the redesign of MTSS program to assist struggling students.
- Reviewed contractual services and replaced them with full-time staff to save budgetary money.

- Adopted next-generation science standard/curriculum to increase student success; implemented algebra for all 8th graders. Applied SchoolNet for teaching system.
- Implemented technology devices for all students K-8 to ensure needs were met.
- Automated application system and attendance system AESOP.
- Created and supported NWEA and Aimsweb throughout the district.
- Negotiated all services and insurance liabilities with unions.
- Supported redesign of MTSS program for district success.

Superintendent

Niles Township District for Special Education | Morton Grove, IL | JULY 2002 – JUNE 2007

Directed the support of 1,000 special education students. Led an administrative team of six Directors of Special Education supporting all school districts. State Approved Director for ten School Districts in Niles Township.

- Managed all legal, financial, and programs of Member Districts related to Special Education Programming.

Assistant Superintendent of Special Education

Naperville Community School District 203 | Naperville, IL | JUNE 1997 – JUNE 2002

Oversaw eight Central Office Administrators who provided service to over 2,000 students with disabilities in 21 different schools. Developed systemic procedures throughout. Managed legal procedures for Special Education due to process hearings.

- Developed evaluation systems, strategic plans, and curriculum programs for over 20,000 students.

EDUCATION

Doctor of Education (Ed.D.) in Educational Leadership | Lewis University

- Certificate of Advanced Studies

Master of Arts in Educational Leadership | National Louis University

Bachelor of Arts in Special Education | Elmhurst College

110

COMMITTEES

- Chair of Oakland Schools Superintendent, Special Education Committee
- Gradual Return to School & Superintendents Legislative Committee for Oakland Schools
- Oakland County's Community Response to Poverty and Homelessness Task Force
- Michigan Association of Superintendents Educational Effectiveness Subgroup

all task undertaken. Key areas of knowledge and skills relevant to the tasks expected to be performed;

- ◆ Financial Statement Audits
- ◆ Internal Control Review
- ◆ Public Presentations
- ◆ Budgeting and Projections
- ◆ General Ledger Accounting
- ◆ Federal Grant Management
- ◆ Financial Reconciliation
- ◆ Financial Analysis
- ◆ Personnel Management

Education

University of Windsor, Windsor, Ontario, Canada

Bachelor of Commerce, Accounting, 1997

Bachelors of Arts, Psychology, 2006

Relevant Work Experience

Director of Business, Fitzgerald Public Schools

2014 to current

Supervised a staff of three accountants and maintained a General Fund budget of \$30 million in addition to managing the Food Service, Sinking and Debt Fund activity. Revised Federal and State internal control procedures as well as internal procedures to identify procedural inefficiencies causing delays in processing payments to vendors and employee wages.

- ❖ Completed the refinancing of 2 Series of Bonds with over 1 Million in savings to residents
- ❖ 4 unqualified financial audits with no significant deficiencies or material weaknesses
- ❖ Prepared numerous budgets between 2015 and 2019 fiscal years with actual to final budget for general fund (excluding grants) within 2% for each year.
- ❖ Prepared and participated in board and committee presentations
- ❖ Served on District team for teachers union contract negotiations
- ❖ Cleared a two year State audit of Title I funding
- ❖ Coordinated Federal, State and internal audits with no internal control weakness or deficiencies identified
- ❖ Provided financial analysis for internal decision making
- ❖ Facilitated resolutions to vendor and employee payment issues through the implementation of numerous internal control procedures
- ❖ Negotiate significant savings in insurance and utilized alternative funding to save general fund dollars (E-rate, supplemental grant, direct/indirect cost rate maximization, etc)

Federal grant management to general accounting procedures.

- ❖ Annually achieved in excess of 40 hours of continuing professional education

Senior Accountant, Arthur Andersen

1999 to 2005

I performed audits of medium to large private and publicly traded companies with a specialization in technology and construction industries. Specialized services performed include due diligence projects and internal control identification, assessment and recommendations for improvement.

Other Relevant Information

Proficient in AS400 platforms, Microsoft Office, QuickBooks, Bi-Tech, Peachtree and Creative Solutions software packages.

Past President of the Macomb/St. Clair School Business Officials Association

Member of the Michigan School Business Officials, currently sitting on Elections Committee

Currently enrolled in the CFO Certification from Michigan School Business Officials (expected completion May 2019 with one course remaining)

Completed Michigan School Business Officials Leadership Institute – Cohort 6

Associate Board Member, Extra Credit Union

Currently working to produce an AS400 Budgeting best practice for Macomb County Districts

Local Organizations: CubMaster Pack 111 and Mite Hockey Coach

112

References

Paul J. Bodiya, Chief Financial Officer

2021 - 2021	Supes Academy <i>Michigan Leadership Institute</i>
2018 - 2020	Doctor of Education - Organizational Leadership Graduated with Honors <i>Oakland University, Rochester, MI</i> Capstone Topic: Building Leader Capacity to Lead Data-Informed Action in K-12 Districts
2011 - 2013	Education Specialist-Educational Leadership Graduated with Honors <i>Oakland University, Rochester, MI</i>
1987 - 1989	Master of Art-Reading <i>Oakland University, Rochester, MI</i>
1981 - 1986	Bachelor of Arts -Elementary Education <i>University of Michigan, Dearborn, MI</i>

Administrative and Leadership Positions

2023 - Present	<p>Assistant Superintendent of Teaching and Learning <i>Hazel Park School District</i></p> <p>Provide leadership and strategic visioning as a member of the Executive Council; Direct and oversee the development and implementation of multiple curricula, instruction, and supervision functions across and within various departments; provide oversight, facilitation, and leadership to the entire district, in support of PK-12 students across diverse backgrounds and abilities; Supervision of the district Teaching and Learning Department including:</p> <ul style="list-style-type: none"> • Facilitation of EC-12 Curriculum, Instruction, and Assessments • Direct supervision of Teaching and Learning Department personnel; general and special education • Implementation of the district's Multi-Tiered System of Support • Coordination and Implementation of the curriculum, instruction, and data components of Power School • Supervision of K-12 instructional coaches and ESL personnel • Responsible for developing and monitoring the teaching and learning department budget • Direct, manage, and implement continuous improvement and accountability • Implementation of state, federal, and local grants • Facilitation of the Curriculum Writing Team and Curriculum Council • Coordination and facilitation of district-wide professional Learning • Provide guidance and supervision for PK-12 building administration
----------------	---

- Implement the district hiring and talent management process for certified staff, including building and central office level leaders
- Collaborate with higher education partners to design and implement embedded teacher preparation programs and alternative degree/education pathways

Fiscal Responsibilities

- Organize, facilitate, and supervise district-wide administration of state, local, and contracted assessments to foster a data-informed culture
- Co-develop and manage the K-12 curriculum, instruction, and assessment budget to maximize district resources and optimize student outcomes
- Provide guidance, professional learning, and coaching for PK-12 leaders to expand instructional leadership skills and support effective school operations
- Procurement and oversight of grants to support building and district programming, and positive student outcomes
- Manage the Implementation of state and federal grants

Noteworthy Accomplishments:

- *Developed and implemented district systems and procedures for compliance with the 3rd Grade Reading Law, student growth components of educator evaluations, and state-level testing*
- *Directed the planning, organization, and launch of a K-8 virtual academy*
- *Led the redesign of the curriculum adoption and renewal and standards alignment process for grades K-12*
- *Redesigned the instructional coaching model to align with the District's Strategic Plan*
- *Cultivated partnership projects and initiatives with Oakland University's School of Education including a teacher pipeline program with numerous pathways to engage in the school environment*
- *Developed and implemented, through a collaborative stakeholder process, the Early Childhood-8 Literacy Roadmap*
- *Visioned and built the district-wide K-12 STEM Pathway, including the launch of a district-wide FIRST Robotics program*
- *Coordinated and implemented the district's Return to Learn state mandated plan and supported district-wide pandemic response actions*

2013 - 2016

District Curriculum Coordinator

West Bloomfield School District

Provided

- Responsible for K-12 instructional technology and related professional development
- Introduced, developed, and conducted virtual professional learning
- Oversaw the adoption and implementation of the district data warehouse system
- Led the development of a district technology vision, articulated actions plans, and provided input for technology bond expenditures
- Provided building-level support and consultation for staff and administration
- Designed and conducted professional development in the areas of instructional technology, assessment practices, data protocols, school improvement, MTSS, and Cultures of Thinking

Noteworthy Accomplishments

- *Established and facilitated various stakeholder committees to facilitate the effective utilization of technology to enhance and*

2017 - Present	Community Center and Winter Relief Grants - 5 Years <i>United Way of Southeast Michigan</i> 585,000
2020 - 2021	Oakland Together Early Childhood Education Response & Recovery Grant <i>United Way of Southeast Michigan</i>
2018 - 2020	Keysight Technologies Foundation <i>Keysight Technologies</i> Provided additional funds to expand the FIRST Robotics presence and competitive edge at Hazel Park High School
2018 - 2021	Amazon AP Computer Science Grant-Hazel Park High School <i>Amazon</i>
2016 - 2019	Summer Mini-Grants-Hazel Park Youth Empowerment Solutions (YES) <i>Alliance of Coalitions for Healthy Communities</i>
2016 - 2021	Michigan Department of Education <i>FIRST Robotics Grants</i>
2016 - 2018	Hazel Park Junior High - PLTW Grant <i>Project Lead The Way</i> Two-year implementation grant supporting the expansion of PLTW courses for all students in grades 6-8.

Service to the Field and Community

2021 - Present	Hazel Park Community Coalition Board Vice President <i>Hazel Park Community Coalition</i>
2014 - Present	Galileo Institute Advisory Board <i>Oakland University</i>
2017 - 2021	Hazel Park Community Coalition <i>School Sector Board Representative</i>
2018 - 2019	Oakland University School of Education and Human Services <i>Quality Assurance Committee</i>
2014 - 2018	Edgemon Oakland University Youth Conference Leadership Committee

- Elementary and Secondary Administration K-12 (ES)

Membership

2020 - 2023

Michigan Association of School Administrators (MASA)

2018 - 2019

International Women's Table (Oakland University)

SUMMARY

experience in multiple practice areas including Contracts, Labor, General Counsel and Employment.

SKILLS

- Contract Negotiations
- Transaction Review
- General Counsel
- Risk Management
- Litigation
- Governmental Law

WORK HISTORY

MAY 2023-PRESENT

General Counsel for Hazel Park Schools

- Contract Negotiations
- Human Resources Guidance
- Title VI, Title VII, and Title IX Training
- ADA and FOIA Coordinator
- Security Coordinator
- Grant Applications

FEBRUARY 2019-February 2023

Manager Civil/Criminal Division and Judicial Assistant | Oakland County Circuit Court

- Manage the general jurisdiction division of the 6th Circuit Court of Oakland County 117
- Advise the Circuit Court bench of forthcoming significant changes to the legal landscape which will impact legal decisions or require modification of processes
- Project and forecast needs of the court and its constituent parts and develop processes to address those needs

School Board Attorney for Hazel Park Schools |

- Legal advisor to the School Board and Administration
- Contract review and negotiations with all bargaining units

FEBRUARY 1995-FEBRUARY 2019

Magistrate | 43rd District Court

- Felony and misdemeanor arraignments
- Issuance of criminal and administrative search warrants
- Adjudicate civil infractions and conduct all informal hearings
- Assisting in the administration and management of the Hazel Park District Court including all aspects of supervision of the clerical staff
- Lead the relocation of the court to temporary facilities for a complete renovation of the existing structure
- Established the Michigan Indigent Defense Commission structure and budget for the 43rd District Court Hazel.

SEPTEMBER 1993-JANUARY 2016

Sole Practitioner |

- General Practice which including significant contract review and transaction negotiations

118

JULY 1992-SEPTEMBER 1993

Attorney | Cummings McClorey, Davis and Acho

- Legal Counsel for the Michigan Municipal Risk Management

- Review of all briefs in motions for summary disposition.

EDUCATION

Juris Doctor

Michigan State University College of Law (formerly Detroit College of Law),

Bachelor of Science: Dual Major in Geology and Economics
Eastern Michigan University, Ypsilanti, Michigan

COMMUNITY

State Bar of Michigan Character and Fitness Committee member of the District 1 Committee.

Director of the Hazel Park Education Foundation.

Elected member of the State Bar of Michigan Representative Assembly for Oakland County.

ACCOMPLISHMENTS

- September 2020 Admitted to practice in the Supreme Court of the United States of America
- August 1992 - Admitted to practice in the United States District Court, Eastern District of Michigan
- May 1992 - Admitted to practice in the State of Michigan

August 22, 2023

Michigan Community Center and Neighborhood Grant Program
Michigan Department of Labor and Economic Opportunity

To Whom It May Concern:

I am writing in support of the Hazel Park School District's application for a Michigan Community Center Grant. This grant would turn a dilapidated and underutilized former elementary school into a thriving community center that would benefit our community's students and adults alike. The City of Hazel Park and the Hazel Park School District have a strong record of partnership and resource sharing. Both entities freely share services and facilities, and, while our current city-owned recreation / community center is currently being renovated and expanded, it will still be nowhere near large enough to accommodate the type of programming called for by this state grant. That is why the availability of the former elementary school presents such a timely and unique opportunity for the Hazel Park community.

Hazel Park has never been a rich area, but we do have a long history of adaptability and resilience in the face of adversity. A State of Michigan Community Center Grant would be of immense value to Hazel Park, and we would fully utilize that value. A Center would help improve educational outcomes for students, promote economic opportunity and community involvement for our residents, as well as provide much-needed services for our senior citizens. Please favorably consider the Hazel Park Schools application for a Michigan Community Center Grant. Thank you.

120

Sincerely,



August 19, 2023

Dear Dr. Kruppe,

I am writing this letter to express my enthusiastic support for the establishment of a community center in the city of Hazel Park. As I work in this tight knit community for nearly 2 years, I believe that a community center will play a vital role in enhancing the quality of life for our residents of Hazel Park. Community centers serve as a place for social interaction, learning, and personal growth. They provide a safe space where individuals from diverse backgrounds can come together, share experiences, and form meaningful connections.

From youth programs that promote education and skill development to sports and wellness initiatives that encourage a healthier lifestyle, a well-equipped community center can address many needs for our city. Moreover, a community center can foster a sense of belonging and unity. With having events and recreational activities, it encourages neighbors to engage in positive interactions that contribute to a stronger, more resilient community.

I am confident that such a facility will not only enrich our lives but also strengthen our ties as neighbors and friends. It has the potential to uplift individuals, families, and the community as a whole. I am committed to supporting this initiative in any way I can, whether through volunteer efforts, spreading the word, or participating in fundraising activities.

I am excited about the positive impact a community center can bring to Hazel Park and am hopeful for the success of this endeavor. Please do not hesitate to reach out if you require further assistance or if there are ways I can contribute to the fulfillment of this project.

August 23, 2023

To Whom It May Concern,

As a partner of Hazel Park Schools, I am writing to affirm the Hazel Park Promise Zone's support for the Hazel Park School District. The Hazel Park Promise Zone Authority and College Access Network work within Hazel Park Schools to provide a tuition-free path to an associate degree for all resident graduates of Hazel Park Schools. In addition, the Hazel Park Promise Zone provides comprehensive college access services, postsecondary success coaching, and community mentors to all graduates of Hazel Park Schools for up to six years post-high school graduation.

We have had tremendous success since 2012 (when the Hazel Park Promise Zone Authority was first established) in increasing Hazel Park High School students' college-going culture and postsecondary attainment. However, research indicates that the earlier we can begin exposing students to the many postsecondary opportunities available to them, the more they will be prepared to avail themselves of these opportunities once they get to high school. We would like to begin working with students and their families in the elementary and middle school years so that they are fully prepared and have a postsecondary plan long before they get to high school. We want every student in Hazel Park Schools to have as many opportunities as possible to succeed in life and beyond.

The Hazel Park Promise Zone proudly partners with Hazel Park Schools and looks forward to our continued partnership to improve the coordination, integration, accessibility, and effectiveness of services for children and families attending schools in vulnerable districts.

In short, we proudly support Hazel Park Schools within our community and hope you strongly consider their proposal.¹²²

Please feel free to reach out with any questions.

Sincerely,

Moussa Traore
Interim Executive Director

August 24, 2023

Dear Dr. Kruppe,

I am writing to express my enthusiastic support for the establishment of a community center in the City of Hazel Park. As the representative for Hazel Park in the State House of Representatives and as a resident of the community, I believe that being awarded the State of Michigan Department of Labor and Economic Opportunity Community Center grant will play a vital role in enhancing the quality of life for our residents.

The Hazel Park community suffered significantly from the pandemic and the award of this grant would allow both the school district and city to provide much needed programming. The conversion of turning an existing school into a community center provides significant value at a discount since costly new construction would be avoided. This is the type of partnership that is good for the community as well as the taxpayers of the State of Michigan.

Please do not hesitate to contact my office if I can be of any further assistance.

Sincerely,

A handwritten signature in black ink, appearing to read "M. A. McFall". The signature is fluid and cursive, with the first name "M." and the last name "McFall" clearly legible.

Mike McFall

August 27, 2020
Michigan Department of Labor
and Economic Opportunity
195 N Michigan Ave
Shelby, MI 49455

Re: Community Center Grant Application

To Whom It May Concern:

On behalf of The Arc of Oakland County, I am reaching out to submit a formal letter of support for the Community Center Grant for which the Hazel Park Schools is applying.

The Arc of Oakland County works to provide expert, individual advocacy and other necessary programs for and on behalf of children and adults with intellectual and developmental disabilities and their families. We count over 2,500 new persons who annually receive our services.

The Arc of Oakland County advocates for the rights and full participation of all children and adults with intellectual and developmental disabilities. We strive to improve systems of supports and services; connect families; inspire our community and influence public policy.

We firmly believe establishing this Community Center at Longfellow Elementary would provide a location for socialization and community engagement, which would be beneficial for the families we serve. The members within our community would have the opportunity to attend a range of activities,¹²⁴ events, and classes that cater to their diverse needs and interests. Furthermore, a Community Center will create a space for people with or without disabilities to gather and create a sense of unity while they engage in different programs, workshops, and recreational activities.

In conclusion, I respectfully request consideration for a Community Center at Longfellow Elementary School to improve the lives of the individuals in Oakland County. Thank you very much.

SENIOR LIVING

August 24, 2023

Re: Michigan Community Center Grant Program; Michigan Department of Labor and Economic Opportunity

To Whom It May Concern:

I am writing to share our support for the proposed community center to convert Hazel Park Schools Longfellow Elementary. As a concerned business located at 777 E. Woodward Heights, near the proposed site, that is working to keep older adults engaged and active, we believe that this idea makes sense, particularly considering the aging of the population over the next 25 to 30 years.

We have seen first-hand the sense of belonging and companionship that comes from interacting with peers. With a community center, residents will have the opportunity to participate in activities, events, and classes that cater to diverse interests and needs. Moreover, a community center will foster a strong sense of unity and support within the community. It can serve as a venue for support groups, wellness programs, and educational workshops. These resources will not only address the physical and emotional needs of our residents but also offer guidance and assistance to their families and caregivers. The collaborative atmosphere will encourage residents to share their experiences, wisdom, and talents, thus creating a vibrant and interconnected community.

In addition, the establishment of a community center, near Baldwin House Hazel Park, will give us an opportunity to promote the safe and affordable senior living option that is here in the community. Many residents are not aware of the benefits of our senior living community and the benefits of on-site socialization, access to 3rd party health care, and a micro-mart available 24/7 to access food, snacks, and beverages when they need them. Having this located so close, will

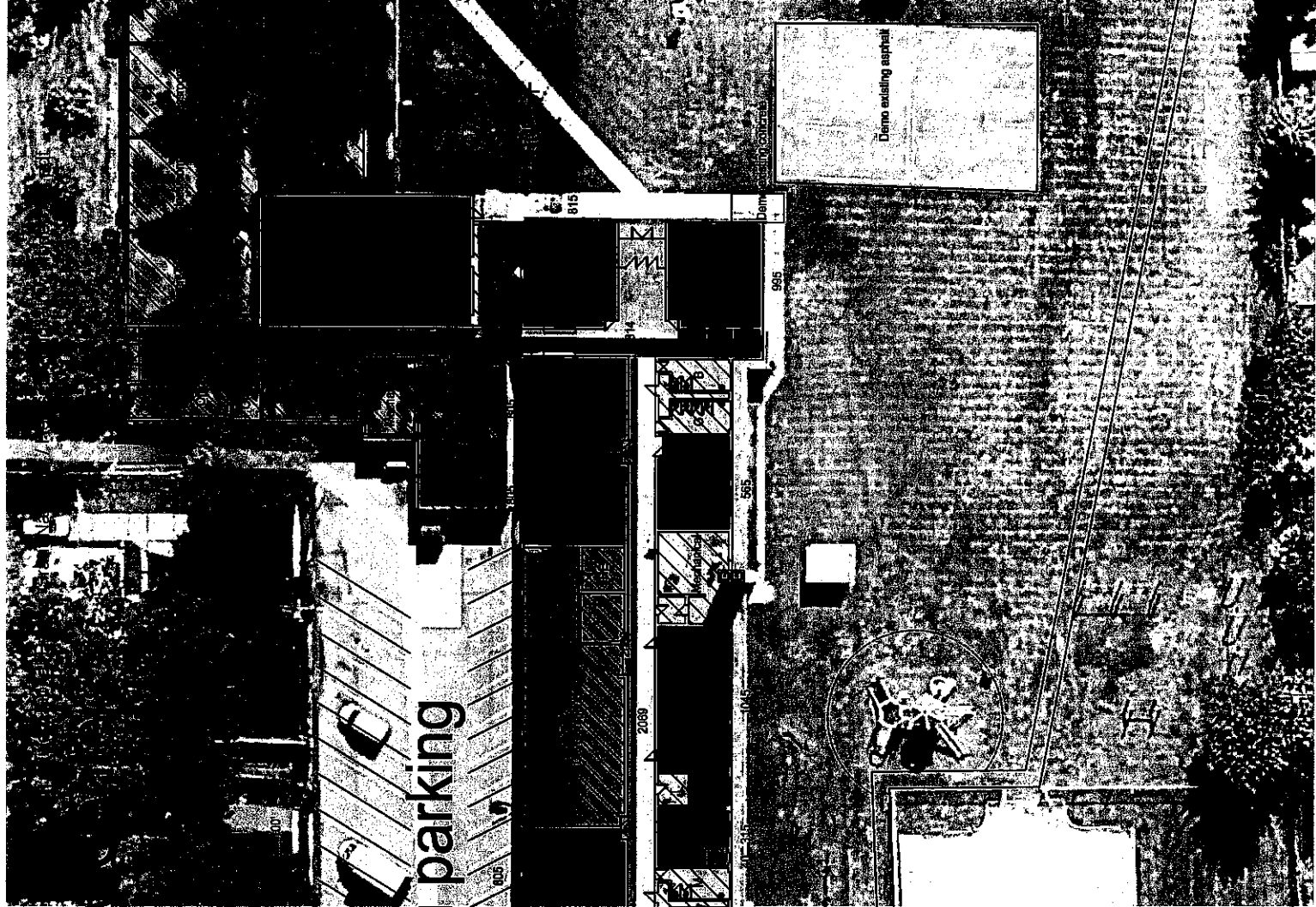

parking

Demo existing asphalt

June 11, 2004

Hazel Park School District
23136 Hughes
Hazel Park, MI 48030

Attention: Mr. Fred M. Nix

Dear Mr. Nix:

Enclosed is the Right-of-Way agreement for the property in Hazel Park, Michigan. I have included a copy for your records.

Please execute and return one copy of the document in the enclosed self-addressed envelope as soon as possible. All printing on the Right-of-Way document must be made with black ink to comply with recording requirements.

Thank you for your assistance in this matter. If you have any questions, please feel free to contact me at 248.594.7137.

Sincerely yours,

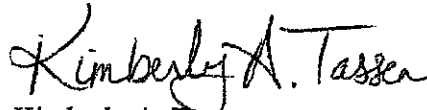

Kimberly A. Tassen
Right-of-Way Facilitator
Royal Oak Service Center

416 Hitchman's Woodland Park a Subdivision of part of the West 1/2 of Section 25, Town 1 North, Range 11 East, Royal Oak Township, Oakland County, Michigan, according to the plat thereof as recorded in Liber 30 of Plats, on page 12, Oakland County Records.

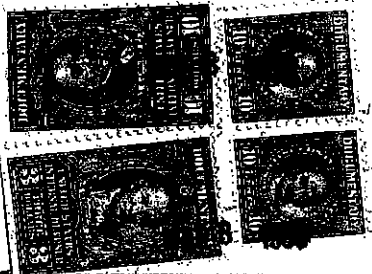

Longfellow

for the sum of One Dollar (\$1.00) and other valuable considerations.

subject to Easements and restrictions of record.

Dated this 24th day of February A. D. 19 50
Signed, Sealed and Delivered in Presence of: Signed and Sealed:

Orval M. O'Toole
Orval M. O'Toole

Salvator Leo Mauro (L. S.)
Salvator Leo Mauro

Lloyd S. Mitchell
Lloyd S. Mitchell

Eva Mauro (L. S.)
Eva Mauro

_____ (L. S.)

_____ (L. S.)

In the STATE OF MICHIGAN, COUNTY OF Oakland ss.

On this 24th day of February A. D. 19 50 before me personally appeared Salvator Leo Mauro and Eva Mauro, his wife.

to me known to be the person ^S described in and who executed the foregoing instrument and acknowledged that they

TITLE INSURANCE -- ABSTRACTS -- ESCROWS

TITLE INSURANCE -- ABSTRACTS -- ESCROWS

of Meagher Lumber and Coal Company, a Michigan Corporation
~~and that the said instrument is the instrument of the corporation aforesaid~~
and that said instrument was signed and sealed in behalf of said
Corporation by authority of its Board of Directors and that said
officer acknowledged said instrument to be the free act and deed of said
Meagher Lumber and Coal Company

Nina Jones Notary Public,
Nina Jones

Wayne County, Mich

My commission expires June 15, 1952

NOTE

If the corporation has no corporate seal, strike out the words between the figures (1) and (2) in the last clause of the instrument and in the acknowledgement.

Meagher Lumber and Coal Co., Mich

and executed by Salvator Mauro and Eva Mauro, his wife, parties
of the first part, to Meagher Lumber and Coal Company, a Michigan Corporation
party
of the second part, and recorded in the Register's Office for the County of Oakland
and State of Michigan in Liber 2315 of Mortgages, on Page 493-492
on the 7th day of September A. D. 19 48

Property: Lot 415 and 1/2 of Lot 416 of Hitchman's Woodland Park
Subdivision in the Township of Royal Oak, according to recorded
Plat, located on South side of Garfield, Oakland County, Mich.

----- is fully paid, satisfied and discharged. 130

In Witness Whereof, Said Meagher Lumber and Coal Company
has caused these presents to be signed by its President ¹ ~~XXXXXX~~
~~company and its authorized agent,~~ this 4th day of March A. D. 19 50

In Presence of

Company
DETROIT, MICHIGAN

Long
1920

This Policy of Title Insurance Witnesseth that the Abstract and Title Guaranty Company of Detroit, Michigan, in consideration of the payment of the agreed premium and charges for examination of title, does hereby insure. SCHOOL DISTRICT #8 TOWNSHIP OF ROYAL OAK

its ^{{successors} ~~heirs or assigns~~ } against all loss or damage, not exceeding -----

One thousand-----dollars

which the insured shall sustain by reason of failure or unmarketability of the title of

School District No. 8, Township of Royal Oak,

_____ to the real estate or interest in real estate described in Schedule A, at the date hereof, excepting only such liens, incumbrances and other matters as are set forth in Schedule B, and subject to the conditions and stipulations, which, together with the aforesaid schedules, are hereto annexed and made a part of this policy.

In Witness Whereof, the Abstract and Title Guaranty Company has caused its corporate seal to be affixed and these presents to be signed by its duly authorized officer

this 8th day of March in the year one

2. Description of the real estate.

Land in the City of Hazel Park, County of Oakland and State of Michigan, described as:

Lot 415 and West 1/2 of Lot 416 Hitchman's Woodland Park a Subdivision of part of the West 1/2 of Section 25, Town 1 North, Range 11 East, Royal Oak Township, Oakland County, Michigan, according to the plat thereof as recorded in Liber 30 of Plats, on Page 12, Oakland County Records.

* * *

SCHEDULE B.

This policy does not insure against any loss or damage arising from:

1. Rights of parties in possession.
2. Existing water, mineral, oil, exploitation rights, easements or encroachments of any nature, or any variation in location, area, or dimension of the land from the descriptions in the chain of title and not appearing therein.
3. Restrictions upon the use of the premises not appearing in the chain of title.
4. Mechanics' Liens not of record.

Conditions of This Policy

1 The Abstract and Title Guaranty

Company will, at its own cost, defend the insured in all actions or proceedings founded on a claim of title or incumbrance prior to date to this policy and thereby insured against. This Company shall have the right, at its own cost, to maintain or defend any action relating to the title hereby insured, or upon or under any covenant relating to such title.

2. No claim for damages shall arise under this policy except under Section 1 of these conditions, and except also in the following cases: (A) Where there has been a final determination in a court of competent jurisdiction, under which the insured may be dispossessed or evicted from the premises covered by this policy or from some part or undivided share or interest therein. (B) Where there has been a final determination adverse to the title as insured, in such a court, upon a lien or incumbrance not excepted in this policy. (C) Where the insured shall have contracted in good faith in writing to sell the insured estate or interest, and the title has been rejected because of unmarketability or an incumbrance not excepted in this policy, and notice in writing of such rejection shall have been given to this company within ten days thereafter. For thirty days after receiving such notice this company shall have the option of paying the loss, of which the insured must present proper proof, or of maintaining or defending either in its own name or, at its option, in the name of the insured some proper action or proceeding, begun, or to be begun in a court of competent jurisdiction, for the purpose of determining the validity of the alleged objection and only in case a final determination is made in such action or proceeding, sustaining the objection to the title, shall this company be liable on this policy. (D) Where a purchaser at a sale under the judgment or order of a court of competent jurisdiction has been relieved by the court from a purchase of the insured estate or interest by reason of the unmarketability of the title, or the existence of some lien or incumbrance not excepted in this policy. (E) Where the insured shall have negotiated a loan on the security of a mortgage on an estate or interest in land insured by this policy, and the title shall have been rejected by the proposed lender because of unmarketability or an incumbrance not excepted in this policy, this Company, if there is no dispute as to the facts, will consent to the submission of the question of the validity of the title, as insured, to some court of competent jurisdiction, and upon the judgment of such court shall then depend the liability of this company, but in no event shall this company be obligated to make any loan in place of the one so rejected. (F) Where the insured shall have transferred the title insured by an instrument containing covenants in regard to title or warranty thereof, and there has been a final judgment rendered in a court of competent jurisdiction against the insured, or the heirs, executors, administrators or successors of the insured on any of such covenants or warranty, because of an incumbrance or a failure of title insured against by this policy.

3. No transfer of this policy shall be made, except by written assent of the Company.

4. Any untrue statement made by the insured or the agent

such paper or pleading, then this policy shall be void, provided, however, that no failure to give such notice shall affect this company's liability, if such failure has not prejudiced and cannot in the future prejudice this company. This company will pay, in addition to the loss, all costs imposed on the insured in litigation carried on by it for the insured under the requirements of this policy; but it will in no case be liable for the fees of any counsel or attorney employed by the insured.

6. In every case where the liability of this company has been definitely fixed in accordance with these conditions, the loss or damage shall be payable within thirty days thereafter, provided, however, that in every case this company may demand a valuation of the insured estate or interest, to be made by three arbitrators or any two of them, one to be chosen by the insured, and one by this company, and the two thus chosen selecting an umpire; and then no right of action shall accrue until thirty days after such valuation shall have been served upon this company, and the insured shall have tendered a conveyance or transfer of the insured estate or interest to a purchaser to be named by this company at such valuation, less the amount of any incumbrance on said insured estate or interest not hereby insured against, and this company shall have failed within that time, said tender being during that time kept good, to find a purchaser for the estate or interest upon such terms. And provided, also, that this company shall always have the right to appeal from any adverse determination; but no appeal shall operate to delay the payment of the loss, if the insured shall give to this company satisfactory security for the repayment to this company of the amount of such loss in case there shall be, ultimately, a determination in favor of this company; and provided, further, that in every case, this company shall have the option of settling the claims or paying this policy in full; and the payment or tender of payment to the full amount of this policy shall determine all liability of this company under it. All payments under this policy shall reduce the amount of the insurance to the extent of such payments. No payment or settlement can be demanded without producing this policy for indorsement of the fact of such payment or settlement. If this policy is lost, indemnity must be furnished to the satisfaction of this company.

7. Whenever this company shall have settled a claim under this policy, it shall be entitled to all the rights and remedies which the insured would have had against any other person or property in respect to such claim had this policy not been made, and the insured will transfer or cause to be transferred to this company such rights, and permit it to use the name of the insured for the recovery or defense thereof. If the payment does not cover the loss of the insured, this company shall be subrogated to such rights, in the proportion which said payment bears to the amount of said loss not covered by said payment. And the insured warrants that such right of subrogation shall vest in this company unaffected by any act of the insured.

8. This policy does not insure against any loss, damage, costs, or diminution of use arising out of the forfeiture of title, or the taking or abridgement of any property right, through the enforcement of

Flushing and Title Guaranty
Company



Owner's Policy
of
Title Insurance

725 Griswold St.
Abstract and Title Guaranty Bldg.
Abstract and Title Guaranty Bldg. Mt. Clemens, Mich.

Detroit, Mich.
Pontiac, Mich.

_____ being known as
416 Garfield Street, together with all improvements and appurtenances,
including all lighting fixtures, shades, Venetian blinds, curtain rods, storm windows and storm doors, screens and awnings,

_____ if any, now on the premises,
and to pay therefor the sum of Five hundred and no/100 (\$500.00) _____ Dollars,
subject to the existing building and use restrictions, easements and zoning ordinances, if any, upon the following conditions,

THE SALE TO BE CONSUMMATED BY:

(Fill in one of the four following paragraphs, and strike out the remainder.)

~~Cash~~ 1. Delivery of the usual Warranty Deed conveying a marketable title. Payment of purchase money is to be
~~Sale~~ made in cash or certified check. House to be removed from location on or
before April 1, 1950

~~Cash Sale~~ 2. Delivery of the usual Warranty Deed conveying a marketable title. Payment of purchase money is to be
~~with New~~ made in cash or certified check. Purchaser agrees that if he is to finance this transaction by obtaining a mort-
~~Mortgage~~ gage, he will do so at his own expense within _____ days from the acceptance of this offer.

~~Sale to~~ 3. Delivery of the usual Warranty Deed conveying a marketable title, subject to mortgage to be deducted
~~Existing~~ from the purchase price. Payment of the purchase money is to be made in cash or certified check less the
~~Mortgage~~ amount owing upon an existing mortgage now on the premises, with accrued interest to date of consumma-
tion, held by _____

_____ upon which there is unpaid
the sum of approximately _____ Dollars,

with interest at _____ per cent, which mortgage requires payments of _____ Dollars
on the _____ day of each and every month, which payments { do not include prepaid taxes and
do include prepaid taxes and insurance. If the Seller has any accumulated funds held in escrow for the payment of any prepaid items,
the Purchaser agrees to reimburse the Seller upon the proper assignment of same. The Purchaser agrees to
assume and pay said mortgage.

~~Sale on~~ 4. Payment of the sum of _____ Dollars
~~Land~~ in cash or certified check, and the execution of a Land Contract upon the BURTON ABSTRACT AND TITLE Co.
~~Contract~~ form, acknowledging payment of that sum and calling for the payment of the remainder of the purchase money
within _____ years from the date of Contract in monthly payments of not less than

_____ Dollars each, which include interest payments
at the rate of _____ per cent per annum, and which { do not include prepaid taxes and insurance.
do include prepaid taxes and insurance.

The covenants herein shall bind and inure to the benefit of the executor, administrators, successors and assigns of the respective parties.

By the execution of this instrument the Purchaser acknowledges the receipt of a copy of this offer.

The closing of this deal shall take place at the office of Lloyd's Realty

Additional conditions, if any: _____

IN PRESENCE OF:
Ernest M. O'Toole

Salvatore L. Manno
Ira Manno L.S.
Purchaser

Dated 2/7/58

Address _____
Phone _____

BROKER'S ACKNOWLEDGMENT OF DEPOSIT

Received from the above named Purchaser the deposit money above mentioned, which will be applied as indicated in Paragraphs 10 and 11 above, or will be returned forthwith after tender if the foregoing offer and deposit is declined.

Address 1920 E. 10 MI. RD., Ferndale, Mich. Lloyd's Realty
Broker

Phone Li. 1-8250 By _____

ACCEPTANCE OF OFFER

TO THE ABOVE NAMED PURCHASER AND BROKER:

The foregoing offer is accepted in accordance with the terms stated, and upon consummation Seller agrees to pay the above Broker a commission of _____ Dollars _____ per cent of the sale price.

The receipt of the above mentioned deposit money on account of the purchase price is acknowledged, which deposit is to be held by { Seller in accordance with Paragraph 11 above. If the deposit money is forfeited for non-performance by Purchaser, the Seller agrees that one-half of such deposit shall be paid to the Broker (not exceeding the amount of commission) for services rendered.

By the execution of this instrument the Seller acknowledges the receipt of a copy of this agreement.

IN PRESENCE OF: _____ School District No. 18, Royal Oak Twp.

South side Garfield Avenue

being known as

Street, together with all improvements and appurtenances, including all lighting fixtures, shades, Venetian blinds, curtain rods, storm windows and storm doors, screens and awnings,

and to pay therefor the sum of Eleven thousand seven hundred twenty and no/100 (\$11,720.00) Dollars, subject to the existing building and use restrictions, assessments and zoning ordinances, if any, upon the following conditions,

THE SALE TO BE CONSUMMATED BY:

(Fill in one of the four following paragraphs, and strike out the remainder.)

Cash Sale 1. Delivery of the usual Warranty Deed conveying a marketable title. Payment of purchase money is to be made in cash or certified check.

Cash Sale with New Mortgage 2. Delivery of the usual Warranty Deed conveying a marketable title. Payment of purchase money is to be made in cash or certified check. Purchaser agrees that if he is to finance this transaction by obtaining a mortgage, he will do so at his own expense within _____ days from the acceptance of this offer.

Sale to Existing Mortgage 3. Delivery of the usual Warranty Deed conveying a marketable title, subject to mortgage to be deducted from the purchase price. Payment of the purchase money is to be made in cash or certified check less the amount owing upon an existing mortgage now on the premises, with accrued interest to date of consummation, held by _____

_____ upon which there is unpaid the sum of approximately _____ Dollars,

with interest at _____ per cent, which mortgage requires payments of _____ Dollars on the _____ day of each and every month, which payments { do not include prepaid taxes and insurance. If the Seller has any accumulated funds held in escrow for the payment of any prepaid items, the Purchaser agrees to reimburse the Seller upon the proper assignment of same. The Purchaser agrees to assume and pay said mortgage. } do

Sale on Land Contract 4. Payment of the sum of _____ Dollars in cash or certified check, and the execution of a Land Contract upon the BURTON ABSTRACT AND TITLE CO. form, acknowledging payment of that sum and calling for the payment of the remainder of the purchase money within _____ years from the date of Contract in monthly payments of not less than _____

_____ Dollars each, which include interest payments at the rate of _____ per cent per annum, and which { do not include prepaid taxes and insurance. } do

respective parties.

By the execution of this instrument the Purchaser acknowledges the receipt of a copy of this offer.

The closing of this deal shall take place at the office of Lloyd's Realty, Agent for school Dist.

Additional conditions, if any: No. 8, Royal Oak Twp.

IN PRESENCE OF:

Ernest M. C. Tule

School Dist. No. 8, Royal Oak Twp.

O. Everett Hysmith L.S.

O. Everett Hysmith L.S.
Secretary

Address _____

Dated 2/8/58 Phone _____

BROKER'S ACKNOWLEDGMENT OF DEPOSIT

Received from the above named Purchaser the deposit money above mentioned, which will be applied as indicated in Paragraphs 10 and 11 above, or will be returned forthwith after tender if the foregoing offer and deposit is declined.

Address 1920 E. 10 Mi. Rd., Ferndale, Mich. Lloyd's Realty

Phone Li. 1-8250 By Ernest M. C. Tule Broker

Salesman

ACCEPTANCE OF OFFER

TO THE ABOVE NAMED PURCHASER AND BROKER:

The foregoing offer is accepted in accordance with the terms stated, and upon consummation Seller agrees to pay the above Broker a commission of { _____ } Dollars _____ per cent of the sale price.

The receipt of the above mentioned deposit money on account of the purchase price is acknowledged, which deposit is to be held by { ~~Broker~~ Seller } in accordance with Paragraph 11 above. If the deposit money is forfeited for non-performance by Purchaser, the Seller agrees that one-half of such deposit shall be paid to the Broker (not exceeding the amount of commission) for services rendered.

By the execution of this instrument the Seller acknowledges the receipt of a copy of this agreement.

IN PRESENCE OF:

Ernest M. C. Tule

Salvatore L. Mauri L.S.

TITLE INSURANCE -- ABSTRACTS -- ESCROWS

park, a Subdivision of part of the West 1/2 of Section 25, Town 1 North Range 11 East, Royal Oak Township, Oakland County, Michigan, according to plat thereof as recorded in Liber 30 on page 12, Oakland County Records.

REGISTER OF DEEDS
Oakland County Mich. } a.s. MAY 8 1950
Received for record
at _____ Vol. K _____ and recorded in
Liber 3572 Page 6-17
of Oakland County Register of Deeds Records.

55
Longfellow

Orrin McQuaid
ORRIN McQUAID, Register of Deeds



TITLE INSURANCE -- ABSTRACTS -- ESCROWS

for the sum of One Dollar (\$1.00) and other valuable considerations.

subject to Easements and restrictions of record.

Dated this 14th day of March A. D. 19 50
Signed, Sealed and Delivered in Presence of:

Signed and Sealed:

Raymond J. Severson
RAYMOND J. SEVERSON

John L. Tryke (L.S.)
JOHN L. TRYKE

Bruce C. Winslow
BRUCE C. WINSLOW

(L.S.)

(L.S.)

(L.S.)

In the STATE OF MICHIGAN, COUNTY OF Stamper ss.

On this 14th day of March
appeared John L. Tryke, a single man;

A. D. 19 50 before me personally

to me known to be the person described in and who executed the foregoing instrument and acknowledged that he

SPECIALIZING IN GREATER
NORTH WOODWARD PROPERTIES

Lloyd's REALTY

MILLIN J. DELK
JAMES E. JONES
ORVAL M. O'TOOLE

1920 EAST TEN MILE ROAD
Ferndale 20, Michigan Phone: Lincoln 1-8250

Mr. John L. Tryke

Lot #866 Hitchman's Woodland Park
Subdivision

March 15, 1960

COMMISSION STATEMENT

Adjustment as per closing statement:

Selling price	\$440.00	
Commission due Lloyd's Realty.....	11.00	
Title Insurance & Search.....	<u>12.00</u>	
Settlement in full.....	23.00	140

Lloyd's Realty by

Lloyd S Mitchell

**1949
CITY TAXES**

DUE JULY 1st
PAYABLE ON OR BEFORE
JULY 31ST WITHOUT PENALTY.
PENALTY \$2 PER MONTH
THEREAFTER.

**TAX RECEIPT
CITY OF HAZEL PARK, MICH.**

No. 02571

**TREASURER'S OFFICE
44-48 W. NINE MILE RD.
GRAN JOHN MI**

After March 1st, 1950 Taxes will be payable
at the County Treasurer's Office, Pontiac, Mich.,
with 4% Penalty and 1/4 of 1% interest per
month UNTIL PAID.

**MAKE ALL CHECKS PAYABLE TO
CITY TREASURER, CITY OF HAZEL PARK**

**Your Taxes Go Delinquent!
PAY NOW!**

NAME AND ADDRESS:

CL366 JOHN L TRYKE
 1908 CLINTON AVE
SD 8 MINN MINN

DESCRIPTION OF THE PROPERTY:
HITCHMAN'S WOODLAND PARK
LOT 366

GENERAL TAX DISTRIBUTION:

141

Gen. \$ 15.00 M

Sewer 2.28 M

CITY TREASURER

Woods Park Public Schools
Woods Park, Michigan

March 13, 1950

Dear Sirs;

Mr. John L. Tryke
1908 Clinton Ave.
Minneapolis, Minnesota

Dear Mr. Tryke:

In reply to your letter of March 9, I wish to state that Lloyd's Realty is attempting to close the property case in your behalf at the earliest possible time.

I talked with Mr. O'Toole, of Lloyd's Realty, since receiving your letter and he states that he has written you relative to final arrangements.

Very truly yours,

Superintendent of Schools

Miss
Mara

Hazel Park Park
Hazel Park, Mich

Dear Sirs;
On Febr. 20
"agreement" for
to be signed and
did so and as
to Lloyd's Real
Michigan;
haven't heard
from them
to it, wrote
they didn't

RECEIVED
FEB 20 1901
MICHIGAN

with you to
your throat
in one breath
your dangle
in end; it
to buy little
little from

you
Jo
1/1

P.S. This is in
role of both
Nitchman's
Part 1 sub.

a subdivision of part of the west half of Section 26, town 1 north, range 11 east, Royal Oak Township, according to the plat thereof as recorded in libber 30 of Plats on page 12, Oakland County Records.

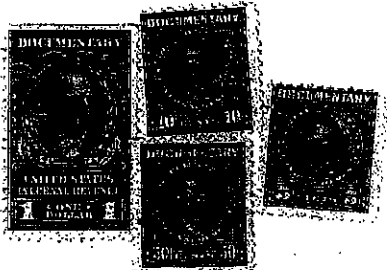

Long

for the sum of One--(\$1.00) dollar and other good and valuable consideration subject to the restrictions of record.

Dated this March 30 th. day of March A.D. 19 50

Signed, Sealed and Delivered in Presence of:

Signed and Sealed:

Frank Castelli
* Frank Castelli
1921 Cameron, Detroit, Mich.

tu
his mark
NICHOLA CASTELLI (L.S.)

Harold G. Griger
* Harold G. Griger
1027 E. 9 Mile Rd. Hazel Park, Mich.

Mamie Castelli (L.S.)
* MAMIE CASTELLI (L.S.)

STATE OF MICHIGAN ss.
County of ~~Wayne~~ Oakland

On this 30 th. day of March A.D. 19 50 before me personally appeared Nichola Castelli and Mamie Castelli, his wife,

to me known to be the person s described in and who executed the foregoing instrument and acknowledged that executed the same as their free act and deed.

Harold G. Griger
Harold G. Griger

My commission expires July 1, A.D. 19 52

Notary Public, ~~Wayne~~ Oakland County, Michigan

BURTON ABSTRACT AND TITLE COMPANY HAS OPERATED CONTINUOUSLY SINCE 1886

MAKE YOUR REAL ESTATE TRANSFERS SAFE BY USING BURTON TITLE INSURANCE

Owner: Nichola Castelli: Lots 367, 368, 369.

Elio Grattarola and Marie Grattarola, his wife: Lots 372, 373, 374,

*over

Encumbrances and exceptions to title:

1. Rights of parties in possession.
 2. Existing water, mineral, oil, exploitation rights, shorements, easements or any variation in location or dimensions not appearing in the chain of title.
 3. Restrictions upon the use of the premises not appearing in the chain of title.
 4. Mechanic Liens not of record.
 5. Taxes or special assessments not open for payment in the office of the County Treasurer.
6. Building and use restrictions as recited in Liber 733, page 138, Deed Records.
 7. An easement over the rear 6 feet of said lots for public utilities.
 8. County and City taxes for the year 1949 are not examined.

Dated March 10, 1950 at 8 am.



Attorney

To: Harold Criger
1027 E. Nine Mile Road
Hazel Park, Michigan

146

We agree to procure from the Burton Abstract and Title Company, on request WITHIN 90 DAYS FROM THE DATE HEREOF, a policy of title insurance in the amount of \$ 7,635.00 as follows:

Form of Policy to be issued: Owner's Policy.

Party to be insured: School District No. 8 Royal Oak Township.

Estate or interest to be insured:

CLOSING STATEMENT;

Lots in Hitchman's Woodland Park Sub. (# 367, 368, and 369)

Seller: Nichola and ~~Mamie~~ Mamie Castell.

Buyer : School District # 8 Royal Oak Twp.

Price: \$1430.00

Paid for option----- \$ 71.50

Due for deed----- \$1358.50

Credits:

Adjustment of taxes:

City Taxes \$12.04--- 3 months \$3.00

County and School \$18.63--- 8 months 12.42

15.42

~~XX~~

~~1223.02~~
~~1545.96~~
1373.92

Expense: Title Policy \$9.75

Rev. stamps 1.65

11.40

11.40

Received payment as stated above.

~~XXXXXXXXXXXX~~
\$1362.52

Don't Let Your Taxes Go Delinquent
PAY NOW!

CL367 NICHOLA CASTELLI
 19211 CAMERON
 SD 8 DETROIT 3 MICH

Gen. \$ 15.00 M

Sewer 2.28 M

DESCRIPTION OF THE PROPERTY: 25
 HITCHMAN'S WOODLAND PARK
 LOT 367

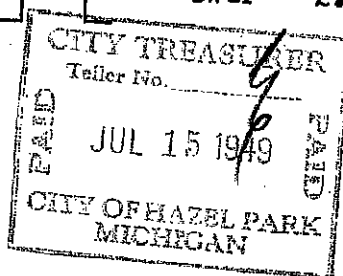

VALUATION	CITY TAX	BLACKTOP	SIDEWALK			INTEREST	TOTAL TAX	1% COLLECTION FEE	TOTAL
220	380							4	384
								PENALTY	
								TOTAL	

WARNING

Compare this statement with your deed or contract before paying tax. If you pay on wrong description the law holds you wholly responsible.

CHECKS

Are accepted only as conditional payment of taxes and if payment is denied upon presentation to the bank the tax will be restored as unpaid to the tax roll without further notice and will be subject to all interest and penalty charges.

RETURN THIS STATEMENT
 WITH YOUR REMITTANCE

PAID NOW!

CL368

SD 8

DESCRIPTION, OR LINE NUMBER: 25

HITCHMAN'S WOODLAND PARK
LOT 368

Gen. \$ 15.00 M

Sewer 2.28 M

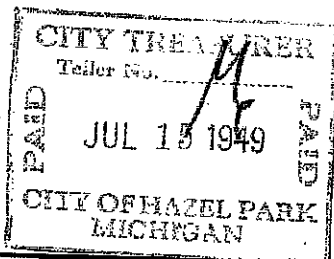

ATION	CITY TAX	BLACKTOP	SIDEWALK			INTEREST	TOTAL TAX	IS COLLECTION FEE	TOTAL
20	380							4	384
								PENALTY	
								TOTAL	

WARNING

Compare this statement with your deed or contract before paying tax. If you pay on wrong description the law holds you wholly responsible.

CHECKS

Are accepted only as conditional payment of taxes and if payment is denied upon presentation to the bank the tax will be restored as unpaid to the tax roll without further notice and will be subject to all interest and penalty charges.

RETURN THIS STATEMENT WITH YOUR REMITTANCE!

CL369

NICHOLA CASTELLI

19211 CAMERON

SD 8

DETROIT 3 MICH

Gen. \$ 15.00 M

Sewer 2.28 M

DESCRIPTION OF PROPERTY: 25

HITCHMAN'S WOODLAND PARK

LOT 369

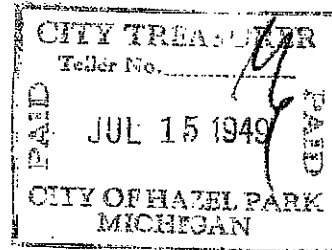

DESCRIPTION	CITY TAX	BLACKTOP	SIDEWALK			INTEREST	TOTAL TAX	1% COLLECTION FEE	TOTAL
250	432							4	436
								PENALTY	
								TOTAL	

WARNING

Compare this statement with your deed or contract before paying tax. If you pay on wrong description the law holds you wholly responsible.

CHECKS

Are accepted only as conditional payment of taxes and if payment is denied upon presentation to the bank the tax will be restored as unpaid to the tax roll without further notice and will be subject to all interest and penalty charges.

**RETURN THIS STATEMENT
WITH YOUR REMITTANCE!**

Don't Let Your Taxes Go Delin
PAY NOW!

CL368

SD 8

TIN, R1E, SEC 25
 HITCHMAN'S WOODLAND PARK
 LOT 368

CREDIT DEBIT
 No. as before
 No. of large

PAID
 JAN 9 1950
 CITY OF HAZEL PARK
 MICHIGAN

VALUATION	GENERAL TAX	TAX	TAX	TAX			TOTAL TAX	1% COLLECTION FEE	TOTAL
220	588							6	594

WARNING
 Compare this statement with your deed or contract before paying tax. If you pay on wrong description the law holds you wholly responsible.

CHECKS
 Are accepted only as conditional payment of taxes and if payment is denied upon presentation to the bank the tax will be restored as unpaid to the tax roll without further notice and will be subject to all interest and penalty charges.

PENALTY	
TOTAL	

1950 DOG LICENSE DUE AND PAYABLE JANUARY 1, 1950
 MALES \$1.00; FEMALES \$2.00; DOUBLE ASSESSMENT MARCH 1, 1950

RETURN THIS STATEMENT WITH YOUR REMITTANCE!

11.40

11.40

DON'T LET YOUR TAXES GO D
PAY NOW

CL369

NICHOLA CASTELLI
19211 CAMERON
DETROIT 3 MICH

SD 8

FIN, RLIE, SEC 25
HITCHMAN'S WOODLAND PARK
LOT 369

City of Hazel Park
School Dept
JAN 9 1950

CITY TREASURER
 TELER No. _____
 JAN 9 1950
 CITY OF HAZEL PARK
 MICHIGAN
 PAID

ALUATION	GENERAL TAX	TAX	TAX	TAX	TAX	TAX	TOTAL TAX	COLLECTION FEE	TOTAL
250	668							7	675
								PENALTY	
								TOTAL	

WARNING
Compare this statement with your deed or contract before paying tax. If you pay on wrong description the law holds you wholly responsible.

CHECKS
Are accepted only as conditional payment of taxes and if payment is denied upon presentation to the bank the tax will be restored as unpaid to the tax roll without further notice and will be subject to all interest and penalty charges.

1950 DOG LICENSE DUE AND PAYABLE JANUARY 1, 1950
MALES \$1.00; FEMALES \$2.00; DOUBLE ASSESSMENT. MARCH 1, 1950

RETURN THIS STATEMENT WITH YOUR REMITTANCE!

TITLE INSURANCE -- ABSTRACTS -- ESCROWS

TITLE INSURANCE -- ABSTRACTS -- ESCROWS

Woodland Park, a Subdivision of part of the West 1/2 of Section 25, Town 1 North, Range 11 East, Royal Oak Township, Oakland County, Michigan, according to plat thereof as recorded in Liber 30 on page 12, Oakland County Records.



Longfellow.

REGISTER OF DEEDS } s.s. MAY 8 1950
Oakland County Mich.
Received for record _____
at _____, and recorded in
Liber *30* Page *61*
of Oakland County Register of Deeds Records.

Orrin McQuaid.
ORRIN McQUAID, Register of Deeds

for the sum of One Dollar (\$1.00) and other valuable considerations.

subject to Easements and restrictions of record.

Dated this *14th* day of March
Signed, Sealed and Delivered in Presence of:

A. D. 19 50
Signed and Sealed:

Lloyd S. Mitchell
Lloyd S. Mitchell

Seberon Shields (L.S.)
Seberon Shields

Orval M. O'Toole
Orval M. O'Toole

(L.S.)

(L.S.)

(L.S.)

In the STATE OF MICHIGAN, COUNTY OF Oakland ss.

On this *14th* day of March
appeared: Seberon Shields, a single man

A. D. 19 50 before me personally

to me known to be the person described in and who executed the foregoing instrument and acknowledged that he

Including all lighting fixtures, shades, Venetian blinds, curtain rods, storm doors, screens and awnings, street, together with all improvements and appurtenances, if any, now on the premises,

and to pay therefor the sum of Eight hundred forty and no/100-(\$840.00) Dollars, subject to the existing building and use restrictions, assessments and zoning ordinances, if any, upon the following conditions:

THE SALE TO BE CONSUMMATED BY:

(Fill in one of the four following paragraphs, and strike out the remainder.)

Cash Sale 1. Delivery of the usual Warranty Deed conveying a marketable title. Payment of purchase money is to be made in cash or certified check.

Cash Sale 2. Delivery of the usual Warranty Deed conveying a marketable title. Payment of purchase money is to be made in cash or certified check. Purchaser agrees that if he is to finance this transaction by obtaining a mortgage, he will do so at his own expense within _____ days from the acceptance of this offer.

Sale to Existing Mortgage 3. Delivery of the usual Warranty Deed conveying a marketable title, subject to mortgage to be deducted from the purchase price. Payment of the purchase money is to be made in cash or certified check less the amount owing upon an existing mortgage now on the premises, with accrued interest to date of consummation, held by _____.

the sum of approximately _____ Dollars, with interest at _____ per cent, which mortgage requires payments of _____ Dollars on the _____ day of each and every month, which payments _____ do not include prepaid taxes and insurance. If the Seller has any accumulated funds held in escrow for the payment of any prepaid items, the Purchaser agrees to reimburse the Seller upon the proper assignment of same. The Purchaser agrees to assume and pay said mortgage.

Sale on Land Contract 4. Payment of the sum of _____ Dollars in cash or certified check, and the execution of a Land Contract upon the Burton Abstract and Title Co. form, acknowledging payment of that sum and calling for the payment of the remainder of the purchase money within _____ years from the date of Contract in monthly payments of not less than _____ Dollars each, which include interest payments at the rate of _____ per cent per annum, and which _____ do not include prepaid taxes and insurance.

5. If the Seller's title to said land is evidenced by an existing land contract with unperfected terms and conditions substantially as above set forth and the cash payment to be made by the undersigned on consummation hereof will pay out the equity, an assignment of the vendor's interest in the land contract, with an agreement by the undersigned to assume the balance owing thereon, will be accepted in lieu of the contract proposed in Paragraph 4 above. If the Seller

March 15, 1950

COMMISSION STATEMENT

Adjustment as per closing statement:

Selling price.....	\$840.00
Commission due Lloyd's Realty 2 1/2%.....	21.00
Title insurance and Search.....	<u>12.00</u>
Total.....	33.00

Lloyd's Realty by Lloyd S Mitchell

School District No. 8, Township of Royal Oak Everett Hyman
Secy.

BURTON ABSTRACT AND TITLE COMPANY HAS OPERATED CONTINUOUSLY SINCE 1866

WOODLAND PARK a subdivision of part of the west half of Section 25, town 1 north, Range 11 East, Royal Oak Township, according to the plat thereof as recorded in Liber 30 of Plats on page 12, Oakland County Records.



Long

MAKE YOUR REAL ESTATE TRANSFERS SAFE BY USING BURTON TITLE INSURANCE

for the sum of One-(\$1.00)-dollar and other good and valuable consideration subject to Restrictions of record.

Dated this 29 th. day of March A.D. 19 50

Signed, Sealed and Delivered in Presence of:

Signed and Sealed:

Harold G. Griger
Harold G. Griger

Elio Grattarola (L.S.)
Elio Grattarola

* Kenneth D. Griger

Marie Grattarola (L.S.)
Marie Grattarola

* _____ (L.S.)

* _____ (L.S.)

* _____ (L.S.)

* _____ (L.S.)

STATE OF MICHIGAN }
County of ~~Wayne~~ Oakland

On this 29 th. day of March A.D. 19 50 before me personally appeared ELIO GRATTAROLA and MARIE GRATTAROLA, his wife,

to me known to be the person s described in and who executed the foregoing instrument and acknowledged that executed the same as their free act and deed.

Harold G. Griger

My commission expires July 1, A.D. 19 52

Notary Public, ~~Wayne~~ Oakland County, Michigan
Oakland

WARRANTY DEED
STATUTORY FORM

The deed on the reverse side of this sheet complies with the provisions of Act 187 P.A. 1881 (M.S.A. 26.571).

In using the form be sure that the following instructions are observed:

1. Print, typewrite or stamp the names of grantor, witnesses and notary below the signatures. (Marked *).
2. Fill in the street and town or city address of the grantee (M.S.A. 26.1221).
3. Male grantees must indicate marital status (M.S.A. 26.561).
4. Grantor should affix the required U. S. revenue stamps amounting to 55 cents for each \$500 or fraction thereof of the actual consideration less any encumbrances not removed by the sale. When the consideration is less than \$100 no stamps are required.
5. The terms used in designating the grantees will determine whether the estate is to be held by the grantee as joint tenants, as tenants in common, as tenants by entitles, or as holders of community property. The proper wording to be used should be obtained from an attorney.
6. If there is not sufficient space on the face of the deed for all of the necessary data the remainder may be placed on the reverse side if the fact is clearly indicated on the face.
7. All writing must be in BLACK or dark blue ink as the deed must be photographed for the record and red, light green and similar inks will not photograph satisfactorily.

Closing Statement:

lots number 372, 373, 374, 375 and 376 Hitchman's Woodland Park, Sub.

Seller : Elio Grattarola and Maria Grattarola, his wife,

Buyer: SCHOOL DISTRICT NUMBER 8 ROYAL OAK TOWNSHIP:

Price: \$2125.00

Paid for option----- 106.25

\$2018.75

Credit : Adjustment of taxes:

City- \$19.20----- 3months \$4.80

County & School- \$29.70 - 8 Mo. \$19.80

24.60

Total-

~~xxx24x13~~
2043.35

Expense: ~~xxxxxxx~~ Title Policy \$16.25

Revenue Stamps 2.75

19.00

amount due Seller for deed----- \$ 2024.35

Received payment as stated above.

Don't Let Your Taxes Go Delin
PAY NOW!

CL372 ELIO GRATTAROLA
 968 FERNHILL AVE
 SD 8 DETROIT MICH

Gen. \$ 15.00 M

Sewer 2.28 M

DESCRIPTION OF PROPERTY: 25
 HITCHMAN'S WOODLAND PARK
 LOT 372

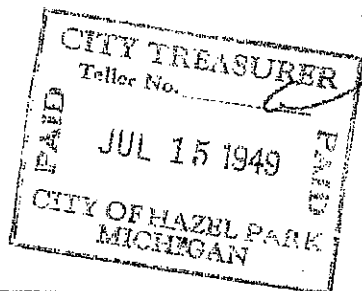

VALUATION	CITY TAX	BLACKTOP	SIDEWALK			INTEREST	TOTAL TAX	1% COLLECTION FEE	TOTAL
220	380							4	384

WARNING

Compare this statement with your deed or contract before paying tax. If you pay on wrong description the law holds you wholly responsible.

CHECKS

Are accepted only as conditional payment of taxes and if payment is denied upon presentation to the bank the tax will be restored as unpaid to the tax roll without further notice and will be subject to all interest and penalty charges.

PENALTY	
TOTAL	

RETURN THIS STATEMENT WITH YOUR REMITTANCE

Don't Let Your Taxes Go Delinquent
PAY NOW!

CL374

ELIO GRATTAROLA

Gen. \$ 15.00 M

Sewer 2.28 M

SD 8

DESCRIPTION OF PROPERTY: 25

HITCHMAN'S WOODLAND PARK

LOT 374

CITY TREASURER
 Teller No. _____
 PAID JUL 15 1949
 CITY OF HAZEL PARK
 MICHIGAN
 PAID

VALUATION	CITY TAX	BLACKTOP	SIDEWALK			INTEREST	TOTAL TAX	COLLECTION FEE	TOTAL
220	380							4	384
								PENALTY	
								TOTAL	

WARNING

Compare this statement with your deed or contract before paying tax. If you pay on wrong description the law holds you wholly responsible.

CHECKS

Are accepted only as conditional payment of taxes and if payment is denied upon presentation to the bank the tax will be restored as unpaid to the tax roll without further notice and will be subject to all interest and penalty charges.

**RETURN THIS STATEMENT
 WITH YOUR REMITTANCE!**

Don't Let Your Taxes Go Delinquent
PAY NOW!

Gen. \$ 15.00 M

CL375

ELIO GRATTAROLA

Sewer 2.28 M

SD 8

DESCRIPTION OF PROPERTY: 25
 TEN, NINE, SECO: 25
 HITCHMAN'S WOODLAND PARK
 LOT 305

CITY TREASURER
 Teller No. _____
 JUL 15 1949
 CITY OF HAZEL PARK
 MICHIGAN
 PAID PAID

VALUATION	CITY TAX	BLACKTOP	SIDEWALK			INTEREST	TOTAL TAX	1% COLLECTION FEE	TOTAL
220	380							4	384

WARNING

Compare this statement with your deed or contract before paying tax. If you pay on wrong description the law holds you wholly responsible.

CHECKS

Are accepted only as conditional payment of taxes and if payment is denied upon presentation to the bank the tax will be restored as unpaid to the tax roll without further notice and will be subject to all interest and penalty charges.

PENALTY	
TOTAL	

**RETURN THIS STATEMENT
 WITH YOUR REMITTANCE!**

Don't Let Your Taxes Go Delinquent
PAY NOW!

CL376

ELIO GRATTAROLA

Gen. \$ 15.00 M

SD 8

Sewer 2.28 M

DESCRIPTION, DISTRICT, PERCENTAGE
 HITCHMAN'S WOODLAND PARK
 LOT 376

CITY TREASURER
 Teller No. _____
 JUL 15 1949
 CITY OF HAZEL PARK
 MICHIGAN
 PAID PAID

VALUATION	CITY TAX	BLACKTOP	SIDEWALK			INTEREST	TOTAL TAX	1% COLLECTION FEE	TOTAL
220	330							4	384

WARNING

Compare this statement with your deed or contract before paying tax. If you pay on wrong description the law holds you wholly responsible.

CHECKS

Are accepted only as conditional payment of taxes and if payment is denied upon presentation to the bank the tax will be restored as unpaid to the tax roll without further notice and will be subject to all interest and penalty charges.

PENALTY	
TOTAL	

RETURN THIS STATEMENT
 WITH YOUR REMITTANCE

Don't Let Your Taxes Go Delinquent
PAY NOW!

CL372 ELIO GRATTAROLA
 968 FERNHILL AVE
 SD 8 DETROIT MICH

FIN, RILE, SEC 25
 HITCHMAN'S WOODLAND PARK
 LOT 372

Property Debt 23.75 %
 at Large 9.10 %
 at Large 2.43 %
 (plus 1953)

CITY OF HAZEL PARK MICHIGAN
 Teller No. _____
 DEC 17 1949
 PAID

50.58 %
 8.57 %

VALUATION	GENERAL TAX	TAX	TAX	TAX			TOTAL TAX	1% COLLECTION FEE	TOTAL
220	588							6	594
								PENALTY	
								TOTAL	

WARNING

Compare this statement with your deed or contract before paying tax. If you pay on wrong description the law holds you wholly responsible.

CHECKS

Are accepted only as conditional payment of taxes and if payment is denied upon presentation to the bank the tax will be restored as unpaid to the tax roll without further notice and will be subject to all interest and penalty charges.

1950 DOG LICENSE DUE AND PAYABLE JANUARY 1, 1950
 MALES \$1.00; FEMALES \$2.00; DOUBLE ASSESSMENT MARCH 1, 1950

RETURN THIS STATEMENT WITH YOUR REMITTANCE!

Don't Let Your Taxes Go Delinquent
PAY NOW!

CL373 ELIO GRATTAROLA

SD 8

FIN, R11E, SEC 25
 HITCHMAN'S WOODLAND PARK
 LOT 373

CITY TREASURER
 Teller No. _____
PAID
 DEC 17 1949
 CITY OF HAZEL PARK
 MICHIGAN

VALUATION	GENERAL TAX	TAX	TAX	TAX			TOTAL TAX	15% COLLECTION FEE	TOTAL
220	588							6	594
<p>WARNING</p> <p>Compare this statement with your deed or contract before paying tax. If you pay on wrong description the law holds you wholly responsible.</p>								<p>CHECKS</p> <p>Are accepted only as conditional payment of taxes and if payment is denied upon presentation to the bank the tax will be restored as unpaid to the tax roll without further notice and will be subject to all interest and penalty charges.</p>	
								PENALTY	
								TOTAL	

1950 DOB LICENSE DUE AND PAYABLE JANUARY 1, 1950
 MALES \$1.00; FEMALES \$2.00; DOUBLE ASSESSMENT MARCH 1, 1950

RETURN THIS STATEMENT WITH YOUR REMITTANCE!

Don't Let Your Taxes Go Delinquent
PAY NOW!

CL374 ELIO GRATTAROLA

SD 8

T1N, R11E, SEC 25
 HITCHMAN'S WOODLAND PARK
 LOT 374

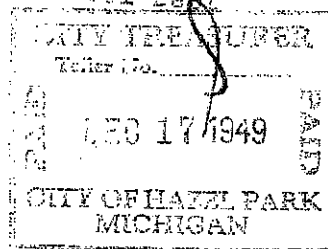

VALUATION	GENERAL TAX	TAX	TAX	TAX			TOTAL TAX	1% COLLECTION FEE	TOTAL
220	588							6	594
WARNING									
Compare this statement with your deed or contract before paying tax. If you pay on wrong description the law holds you wholly responsible.								CHECKS	
								Are accepted only as conditional payment of taxes and if payment is denied upon presentation to the bank this tax will be restored as unpaid to the tax roll without further notice and will be subject to all interest and penalty charges.	
								PENALTY	
								TOTAL	

1950 DDB LICENSE DUE AND PAYABLE JANUARY 1, 1950
MALES \$1.00; FEMALES \$2.00; DOUBLE ASSESSMENT MARCH 1, 1950

RETURN THIS STATEMENT WITH YOUR REMITTANCE!

Don't Let Your Taxes Go Delinquent
PAY NOW!

CL375 ELIO GRATTAROLA

SD 8

T1N, R11E, SEC 25
 HITCHMAN'S WOODLAND PARK
 LOT 375

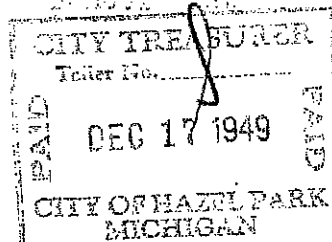

VALUATION	GENERAL TAX	TAX	TAX	TAX		TOTAL TAX	1% COLLECTION FEE	TOTAL
220	5.88						6	5.94
							PENALTY	
							TOTAL	

WARNING

Compare this statement with your deed or contract before paying tax. If you pay on wrong description the law holds you wholly responsible.

CHECKS

Are accepted only as conditional payment of taxes and if payment is denied upon presentation to the bank the tax will be restored as unpaid to the tax roll without further notice and will be subject to all interest and penalty charges.

1950 DOG LICENSE DUE AND PAYABLE JANUARY 1, 1950
 MALES \$1.00; FEMALES \$2.00; DOUBLE ASSESSMENT, MARCH 1, 1950

RETURN THIS STATEMENT WITH YOUR REMITTANCE!

Don't Let Your Taxes Go Delinquent
PAY NOW!

CL376 ELIO GRATTAROLA

SD 8

T1N, R11E, SEC 25
 HITCHMAN'S WOODLAND PARK
 LOT 376

5.94
2.97

Property Dept. .25 %
 City of Hazel Park 9.10 %
 State of Michigan 7.00 %

CITY TREASURER
 Teller No. _____
PAID
 DEC 17 1949
PAID
 CITY OF HAZEL PARK
 MICHIGAN

VALUATION	GENERAL TAX	TAX	TAX	TAX		TOTAL TAX	1% COLLECTION FEE	TOTAL
220	588						6	594
<p style="text-align: center;">WARNING</p> <p>Compare this statement with your deed or contract before paying tax. If you pay on wrong description the law holds you wholly responsible.</p>							<p style="text-align: center;">CHECKS</p> <p>Are accepted only as conditional payment of taxes and if payment is denied upon presentation to the bank the tax will be restored as unpaid to the tax roll without further notice and will be subject to all interest and penalty charges.</p>	
							TOTAL	

1950 DOB LICENSE DUE AND PAYABLE JANUARY 1, 1950
MALES \$1.00; FEMALES \$2.00; DOUBLE ASSESSMENT MARCH 1, 1950

RETURN THIS STATEMENT WITH YOUR REMITTANCE!

BURTON ABSTRACT AND TITLE COMPANY HAS OPERATED CONTINUOUSLY SINCE 1866

whose address is 22750 Highland Avenue, Hazel Park, Michigan

part Y of the second part,

Witnesseth, That the said party of the first part, for and in consideration of the sum of One Dollar and other considerations - - - - - Dollars

to it in hand paid by the said part Y of the second part, the receipt whereof is hereby confessed and acknowledged, does by these presents grant, bargain, sell, remise, release, alien and confirm unto the said part Y of the second part, and to its successors ~~here~~ and assigns, Forever, all the following land, situate and being in the City of Hazel Park County of Oakland and State of Michigan, known and described as follows, to wit:

Lot Three hundred seventy-seven (377) of HITCHMAN'S WOODLAND PARK SUBDIVISION of part of the west one-half of Section 25, T.1 N.R.11 E. 12 according to the plat recorded in Liber 30 of Plats, page 12 Oakland County Records.

This property is sold subject to an easement as shown on the plat of said subdivision.

Subject to restrictions of record



Rev. 55 Longfellow 7357

CLERK OF COUNTY TREASURY'S CERTIFICATE
No. 4 Dated April 23, 1950
I hereby certify that the above described TAX
LISES or TITLES held by the State or any its
individual against this tax classification, and
not taxes on same recorded in the last years
preceding to the date of this instrument, as
appears by the records in his office except
as stated otherwise on this certificate
CLERK OF COUNTY TREASURY

CLERK OF DEEDS
Oakland County Mich. APR 28 1950
Received for record
at 2:36 o'clock P.M. and recorded in
Liber 3571 Page 216
of Oakland County Registrar of Deeds Records.

Oliver H. Smith,
GUYMON McCLAND, Register of Deeds

MAKE YOUR REAL ESTATE TRANSFERS SAFE BY USING BURTON TITLE INSURANCE

Company
DETROIT, MICHIGAN

This Policy of Title Insurance Witnesseth that the Abstract and Title Guaranty Company of Detroit, Michigan, in consideration of the payment of the agreed premium and charges for examination of title, does hereby insure. SCHOOL DISTRICT #8

TOWNSHIP OF ROYAL OAK

its ^{{successors} ~~heirs and assigns~~ } against all loss or damage, not exceeding -----

Five hundred-----dollars

which the insured shall sustain by reason of failure or unmarketability of the title of

Redford Land Co., a Michigan Corporation

_____ to the real estate or interest in real estate described in Schedule A, at the date hereof, excepting only such liens, incumbrances and other matters as are set forth in Schedule B, and subject to the conditions and stipulations, which, together with the aforesaid schedules, are hereto annexed and made a part of this policy.

In Witness Whereof, the Abstract and Title Guaranty Company has caused its corporate seal to be affixed and these presents to be signed by its duly authorized officer

this 18th day of April in the year one

thousand nine hundred fifty.

2. Description of the real estate.

Land in the City of Hazel Park, County of Oakland, and State of Michigan, described as:

Lot 377 Hitchman's Woodland Park a Subdivision of part of the West 1/2 of Section 25, Town 1 North, Range 11 East, Royal Oak Township, Oakland County, Michigan, according to the plat thereof as recorded in Liber 30 of Plats, on Page 12, Oakland County Records.

* * *

SCHEDULE B.

This policy does not insure against any loss or damage arising from:

1. Rights of parties in possession.
2. Existing water, mineral, oil, exploitation rights, easements or encroachments of any nature, or any variation in location, area, or dimension of the land from the descriptions in the chain of title and not appearing therein.
3. Restrictions upon the use of the premises not appearing in the chain of title.
4. Mechanics' Liens not of record.
5. Special assessments unless the roll is open for payment in the office of a County Treasurer or the office of the City Treasurer, if the land is within the City of Detroit.
6. Easement over the rear 6 feet of said lot as shown on plat.

Conditions of This Policy

1 The Abstract and Title Guaranty

Company will, at its own cost, defend the insured in all actions or proceedings founded on a claim of title or incumbrance prior to date to this policy and thereby insured against. This Company shall have the right, at its own cost, to maintain or defend any action relating to the title hereby insured, or upon or under any covenant relating to such title.

2. No claim for damages shall arise under this policy except under Section I of these conditions, and except also in the following cases: (A) Where there has been a final determination in a court of competent jurisdiction, under which the insured may be dispossessed or evicted from the premises covered by this policy or from some part or undivided share or interest therein. (B) Where there has been a final determination adverse to the title as insured, in such a court, upon a lien or incumbrance not excepted in this policy. (C) Where the insured shall have contracted in good faith in writing to sell the insured estate or interest, and the title has been rejected because of unmarketability or an incumbrance not excepted in this policy, and notice in writing of such rejection shall have been given to this company within ten days thereafter. For thirty days after receiving such notice this company shall have the option of paying the loss, of which the insured must present proper proof, or of maintaining or defending either in its own name or, at its option, in the name of the insured some proper action or proceeding, begun, or to be begun in a court of competent jurisdiction, for the purpose of determining the validity of the alleged objection and only in case a final determination is made in such action or proceeding, sustaining the objection to the title, shall this company be liable on this policy. (D) Where a purchaser at a sale under the judgment or order of a court of competent jurisdiction has been relieved by the court from a purchase of the insured estate or interest by reason of the unmarketability of the title, or the existence of some lien or incumbrance not excepted in this policy. (E) Where the insured shall have negotiated a loan on the security of a mortgage on an estate or interest in land insured by this policy, and the title shall have been rejected by the proposed lender because of unmarketability or an incumbrance not excepted in the policy, this Company, if there is no dispute as to the facts, will consent to the submission of the question of the validity of the title, as insured, to some court of competent jurisdiction, and upon the judgment of such court shall then depend the liability of this company, but in no event shall this company be obligated to make any loan in place of the one so rejected. (F) Where the insured shall have transferred the title insured by an instrument containing covenants in regard to title or warranty thereof, and there has been a final judgment rendered in a court of competent jurisdiction against the insured, or the heirs, executors, administrators or successors of the insured on any of such covenants or warranty, because of an incumbrance or a failure of title insured against by this policy.

3. No transfer of this policy shall be made, except by written assent of the Company.

4. Any untrue statement made by the insured or the agent

such paper or pleading, then this policy shall be void, provided, however, that no failure to give such notice shall affect this company's liability, if such failure has not prejudiced and cannot in the future prejudice this company. This company will pay, in addition to the loss, all costs imposed on the insured in litigation carried on by it for the insured under the requirements of this policy; but it will in no case be liable for the fees of any counsel or attorney employed by the insured.

6. In every case where the liability of this company has been definitely fixed in accordance with these conditions, the loss or damage shall be payable within thirty days thereafter, provided, however, that in every case this company may demand a valuation of the insured estate or interest, to be made by three arbitrators or any two of them, one to be chosen by the insured, and one by this company, and the two thus chosen selecting an umpire; and then no right of action shall accrue until thirty days after such valuation shall have been served upon this company, and the insured shall have tendered a conveyance or transfer of the insured estate or interest to a purchaser to be named by this company at such valuation, less the amount of any incumbrance on said insured estate or interest not hereby insured against, and this company shall have failed within that time, said tender being during that time kept good, to find a purchaser for the estate or interest upon such terms. And provided, also, that this company shall always have the right to appeal from any adverse determination; but no appeal shall operate to delay the payment of the loss, if the insured shall give to this company satisfactory security for the repayment to this company of the amount of such loss in case there shall be, ultimately, a determination in favor of this company; and provided, further, that in every case, this company shall have the option of settling the claims or paying this policy in full; and the payment or tender of payment to this company under it. All payments under this policy shall reduce the amount of the insurance to the extent of such payments. No payment or settlement can be demanded without producing this policy for indorsement of the fact of such payment or settlement. If this policy is lost, indemnity must be furnished to the satisfaction of this company.

7. Whenever this company shall have settled a claim under this policy, it shall be entitled to all the rights and remedies which the insured would have had against any other person or property in respect to such claim had this policy not been made, and the insured will transfer or cause to be transferred to this company such rights, and permit it to use the name of the insured for the recovery or defense thereof. If the payment does not cover the loss of the insured, this company shall be subrogated to such rights, in the proportion which said payment bears to the amount of said loss not covered by said payment. And the insured warrants that such right of subrogation shall vest in this company unaffected by any act of the insured.

8. This policy does not insure against any loss, damage, costs, or diminution of use arising out of the forfeiture of title, or the taking or abridgement of any property right, through the enforcement of

**Abstract and Title Guaranty
Company**



**Owner's Policy
of
Title Insurance**

725 Orchard St.
Abstract and Title Guaranty Bldg.
Abstract and Title Guaranty Bldg. Mt. Clemens, Mich.

Detroit, Mich.
Pontiac, Mich.
Mt. Clemens, Mich.

TITLE INSURANCE -- ABSTRACTS -- ESCROWS

Hitchman's Woodland Park a Subdivision of part of the West 1/2 of Section 25, Town 1 North, Range 11 East, Royal Oak Township, Oakland County, Michigan, according to the plat thereof as recorded in Liber 30 of Plats, on page 12, Oakland County Records.



Lanzetta

REGISTER OF DEEDS }
Oakland County Mich. } s.s. MAY 8 1950

Received for record
at _____ of block _____ and recorded in
Liber _____ Page _____
of Oakland County Register of Deeds Records.

Orrin McQuaid
ORRIN McQUAID, Register of Deeds

for the sum of One Dollar (\$1.00) and other valuable considerations.

subject to Easements and restrictions of record.

Dated this Fourth day of April

A. D. 19 50

Signed, Sealed and Delivered in Presence of:

Signed and Sealed:

V. D. Farrand
V. D. Farrand

Ettore Scocchio
Ettore Scocchio (L. S.)

Leora Batcheller
Leora Batcheller

Leonilda Scocchio
Leonilda Scocchio (L. S.)

(L. S.)

(L. S.)

California
in the STATE OF MICHIGAN, COUNTY OF Los Angeles ss.

On this Fourth day of April A. D. 19 50 before me personally
appeared *Ettore Scocchio and Leonilda Scocchio, his wife*

I, _____ the person s described in and who executed the foregoing instrument and acknowledged that they

TITLE INSURANCE -- ABSTRACTS -- ESCROWS

Ettore Scocchio

Lots #378, 379 & 380 Hitchman's Woodland
Park Subdivision.

March 1, 1950

COMMISSION STATEMENT

Selling price.....	\$1275.00
Commission due Lloyd's Realty.....	31.88
Title Insurance & Search.....	<u>12.00</u>
Settlement in full,.....	\$45.88

Lloyd's Realty by Lloyd S Mitchell

179

School Dist. No. 8, Royal Oak Township Ernest Hyonich

Witnesseth, That the said part SS of the first part, for and in consideration of the sum of One Dollar (\$1.00) and other valuable considerations Dollars,

to them in hand paid by the said part V of the second part, the receipt whereof is hereby confessed and acknowledged, do by these presents grant, bargain, sell, remise, release, alien and confirm unto the said part V of the second part, and its SUCCESSORS heirs and assigns, FOREVER, all that certain piece or parcel of land situate and being in the City of Hazel Park County of Oakland and State of Michigan, and described as follows, to-wit: Lot No. 413 Hitchman's Woodland Park Subdivision

Long fellow



REGISTER OF DEEDS
Oakland County Mich. } S.S. AUG 7 1950

Received for record
at 12:16 o'clock P.M. and recorded in
Lib. 2616 Page 517-18
of Oakland County Register of Deeds Records.

Orrin McQuaid
ORRIN McQUAID, Register of Deeds

NOTICE TO TAXPAYERS: The State of Michigan levies a tax on all real estate. The tax is assessed on the value of the property as of the first day of January in each year. The tax is payable on or before the first day of March in each year. If the tax is not paid by that date, interest will be charged on the amount due. The tax is payable to the County Treasurer. The County Treasurer will issue a receipt for the amount paid. If you have any questions, please contact the County Treasurer's Office.

Together with all and singular the hereditaments and appurtenances thereunto belonging or in anywise appertaining: To Have and to Hold the said premises, as herein described, with the appurtenances, unto

In Witness Whereof, The said parties of the first part ha^{ve} hereunto set their hands and

seal & the day and year first above written.
Signed, Sealed and Delivered in Presence of

[L. S.] Charles S. Berman

[L. S.] Maxine Berman

[L. S.] _____

[L. S.] _____

Robert E. Hill
Abe Berman

STATE OF MICHIGAN

County of OAKLAND

On this TWENTY NINTH day of July in the year 1935 before me, one thousand nine hundred and fifty

in and for said County, personally appeared CHARLES S BERMAN + MAXINE BERMAN

to me known to be the person described in and who executed the within instrument, who acknowledged the same to be THEIR free act and deed.

Notary Public, Edith L. Flynn
Notary Public, Edith L. Flynn
My commission expires Notary Public, Oakland County, Michigan

My Commission Expires September 29, 1935

1. Where changes is made to corporation or partnership, the following may be inserted, "in succession," and draw a line through the word "here".

and
ed,
ate
ion

TITLE INSURANCE -- ABSTRACTS -- ESCROWS

park, a subdivision or part of the West 1/2 of Section 25, Town 1 North, Range 11 East, Royal Oak Township, Oakland County, Michigan, according to plat thereof as recorded in Liber 30 on page 12, Oakland County Records.



Longfellow

REGISTER OF DEEDS
Oakland County Mich. } ss. MAY 8 1950
Received for record _____
at _____ and recorded in
Liber *25-24* Page *611*
of Oakland County Register of Deeds Records.

Orrin McQuaid
ORRIN McQUAID, Register of Deeds

TITLE INSURANCE -- ABSTRACTS -- ESCROWS

for the sum of One Dollar (\$1.00) and other valuable consideration.
subject to Easements and Restrictions of Record.

Dated this *15th* day of March A. D. 19 50
Signed, Sealed and Delivered in Presence of: Signed and Sealed:

Lloyd S. Mitchell
Lloyd S. Mitchell
Orval M. O'Toole
Orval M. O'Toole

Angelo Gallerani (L.S.)
Angelo Gallerani
Ernesta Gallerani (L.S.)
Ernesta Gallerani

(L.S.)
(L.S.)

In the STATE OF MICHIGAN, COUNTY OF Oakland ss.
On this *15th* day of March A. D. 19 50 before me personally
appeared *Angelo Gallerani and Ernesta Gallerani, his wife.*

to me known to be the person ^S described in and who executed the foregoing instrument and acknowledged that they

WITNESSETH: that the said party of the first part, for and in consideration of the sum of Seven hundred twenty-five (\$725.00) dollars to it in hand paid by the said party of the second part, the receipt whereof is hereby confessed and acknowledged, does by these presents, grant, bargain, sell, remise, release, alien and confirm unto the said party of the second part, and his heirs and assigns FOREVER, And that certain piece or parcel of land, situate and being in the Township of Royal Oak county of Oakland and state of Michigan, known and described as follows, to-wit: Lot numbered Four hundred four-teen (14) of HITCHMAN'S WOODLAND PARK SUBDIVISION of part of the west half of Section 25, T. 1 N. R. 11 E. according to the plat re- corded in Liber 30 of Plans, page 12 Oakland County Records.

This property is sold subject to an easement as shown on the plat of said subdivision.

RESTRICTIONS:—As a part of the consideration of said deed, second party hereby agrees that no building shall be erected on the prem- ises except a dwelling house costing not less than Fifteen Hundred Dollars and to be set back twenty feet from the front lot line and the buildings which ordinarily go with a dwelling house. On Joan R Street and on the Van Mile Road, stores and business places may be erected costing not less than Two Thousand Dollars and the buildings which ordinarily go with stores. On Joan R Street and on the Van Mile Road no business places may be built up to the front lot line. No building, or any portion of same, shall be sold, rented or allowed to be occupied by any person of negro blood.



[Faint, illegible text, likely a signature or additional notary information.]

Together with all and singular appurtenances and appurtenances thereto in anywise so pertaining, TO HAVE AND TO HOLD the said premises, with the appurtenances unto the said party of the second part, and to his heirs and assigns FOREVER.

RECEIVED

AMERICAN NATIONAL BANK

[Handwritten signature]

AMERICAN NATIONAL BANK

AMERICAN NATIONAL BANK

AMERICAN NATIONAL BANK

AMERICAN NATIONAL BANK

AMERICAN NATIONAL BANK

AMERICAN NATIONAL BANK

AMERICAN NATIONAL BANK

AMERICAN NATIONAL BANK

AMERICAN NATIONAL BANK

AMERICAN NATIONAL BANK

DATE

20th JAN 1950

AMERICAN NATIONAL BANK

[Handwritten signature]

AMERICAN NATIONAL BANK

AMERICAN NATIONAL BANK

AMERICAN NATIONAL BANK

AMERICAN NATIONAL BANK

AMERICAN NATIONAL BANK

Secretary

[Handwritten signature]

President

[Handwritten signature]

AMERICAN NATIONAL BANK

AMERICAN NATIONAL BANK

and sealed with its corporate seal, the day and year first above written.



[Handwritten signature]

[Handwritten signature]

changed, sealed and delivered in presence of

Angelo Gallerani and
Ernesta Gallerani, his wife.

414 Hitchmans Woodland Park
Subdivision
March 1, 1950

COMMISSION STATEMENT

Adjustment as per closing statement:

Selling price.....	\$500.00
Commission due Lloyd's Realty.....	11.63
Title Insurance & Search.....	<u>12.00</u>
Settlement in full.....	\$33.63 - 23.63

*10.00 overpayment
returned by check # 2033*

Lloyd's Realty by Lloyd S Mitchell

School Dist. No. 8, Royal Oak Township by Everet Hyomink
Secy.

East half of lot 410 and all of lots number 417, 420, 419, 420, 421, 422 and 423 "HITCHMAN'S WOODLAND PARK" a subdivision of part of the west half of Section 25, town 1 north, range 11 east, Royal Oak Township, according to the plat thereof as recorded in liber 30 of Plats on page 12, Oakland County Records.



BURTON ABSTRACT AND TITLE COMPANY HAS OPERATED CONTINUOUSLY SINCE 1866

MAKE YOUR REAL ESTATE TRANSFERS SAFE BY USING BURTON TITLE INSURANCE

for the sum of **ONE-(\$1.00)-dollar** and other good and valuable consideration
 subject to **Restrictions of record.**

Long

Dated this **29** th. day of **March** A.D. 19 **50**

Signed, Sealed and Delivered in Presence of:

Signed and Sealed:

Harold G. Criger
 * **Harold G. Criger**

Fred Desantis
 * **FRED DESANTIS** (L.S.)

Kenneth D. Criger
 * **Kenneth D. Criger**

Mary Desantis
 * **MARY DESANTIS** (L.S.)

 * (L.S.)

 * (L.S.)

STATE OF MICHIGAN
 COUNTY OF **Oakland**

On this **29** th. day of **March** A.D. 19 **50** before me personally
 appeared **FRED DESANTIS and MARY DESANTIS, his wife**

to me known to be the person **S** described in and who executed the foregoing instrument and acknowledged that
 executed the same as **their** free act and deed.

My commission expires **July 1,** A.D. 19**52**

Harold G. Criger
 Notary Public, **Oakland** County, Michigan
Harold G. Criger **Oakland**

WARRANTY DEED
STATUTORY FORM

The deed on the reverse side of this sheet conforms with the provisions of Act 187 P.A. 1981 (M.S.A. 46.371).

In using the form be sure that the following instructions are observed:

1. Print, typewrite or stamp the names of grantee, witnesses and notary below the signatures. (Marked *).
2. Fill in the street and town or city address of the grantee (M.S.A. 26.1221).
3. Male grantors must indicate marital status (M.S.A. 26.581).
4. Grantor should affix the required U. S. revenue stamps amounting to 55 cents for each \$500 or fraction thereof of the actual consideration less any encumbrance not removed by the sale. When the consideration is less than \$100 no stamps are required.
5. The terms used in designating the grantees will determine whether the estate is to be held by the grantees as joint tenants, as tenants in common, as tenants by entireties, or as holders of community property. The proper wording to be used should be obtained from an attorney.
6. If there is not sufficient space on the face of the deed for all of the necessary data the remainder may be placed on the reverse side if the fact is clearly indicated on the face.
7. All writing must be in BLACK or dark blue ink as the deed must be photographed for the record and red, light green and similar inks will not photograph satisfactorily.

Closing Statement
Lots in Hitchman's Woodland Park Sub.
(E. 122 of lot 416 and all of lots 417 to 423 Inc.)

Seller: Fred DeSantis and Mary DeSantis

Buyer: School District # 8 Royal Oak Twp.

Price \$4080.00

Paid for option-----\$ 204.00

3876.00

Credits:

Adjustment of taxes--

City taxes: \$32.03---- 3 months. \$8.00

County & School \$49.50---- 8 months. \$33.00

41.00

total --- 3917.00

Title Policy \$26.00

Revenue Stamps \$ 4.95

Totale----- \$30.95

30.95

Amount due seller on closing-----\$3886.05

Received payment as above.

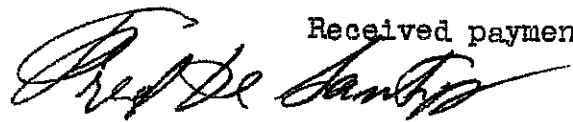

Don't Let Your Taxes Go Delinquent
PAY NOW!

CL417-23 FRED DE SANTIS
19260 HULL ST
SD 8 DETROIT MICH

Gen. \$ 15.00 M

Sewer 2.28 M

DESCRIPTION, OR PROPERTY: 25
HITCHMAN'S WOODLAND PARK
@ 1/2 OF LOT 416 & ALL OF LOTS
417 TO 423 INCL

CITY TREASURER
 Teller No. _____
PAID JUL 30 1949 **PAID**
CITY OF HAZEL PARK
MICHIGAN

VALUATION	CITY TAX	BLACKTOP	SIDEWALK			INTEREST	TOTAL TAX	1% COLLECTION FEE	TOTAL
1835	3171							32	3203
								PENALTY	
								TOTAL	

WARNING

Compare this statement with your deed or contract before paying tax. If you pay on wrong description the law holds you wholly responsible.

CHECKS

Are accepted only as conditional payment of taxes and if payment is denied upon presentation to the bank the tax will be restored as unpaid to the tax roll without further notice and will be subject to all interest and penalty charges.

RETURN THIS STATEMENT WITH YOUR REMITTANCE!

2153

Don't Let Your Taxes Go De
PAY NOW

CL417-23 FRED DE SANTIS
 19260 HULL ST
 SD 8 DETROIT MICH
 T1N, R11E, SEC 25
 HITCHMAN'S WOODLAND PARK
 E 1/2 OF LOT 416 & ALL OF LOTS
 417 TO 423 INCL

CITY TREASURER
 PAID JAN 7 1950 PAID
 CITY OF HAZEL PARK
 MICHIGAN

VALUATION	GENERAL TAX	TAX	TAX	TAX		TOTAL TAX	15% COLLECTION FEE	TOTAL
1835	4901						49	4950
<p style="text-align: center;">WARNING</p> <p>Compare this statement with your deed or contract before paying tax. If you pay on wrong description the law holds you wholly responsible.</p> <p style="text-align: center;">CHECKS</p> <p>Are accepted only as conditional payment of taxes and if payment is denied upon presentation to the bank the tax will be restored as unpaid to the tax roll without further notice and will be subject to all interest and penalty charges.</p>							PENALTY	
							TOTAL	

1950 DOG LICENSE DUE AND PAYABLE JANUARY 1, 1950
 MALES \$1.00; FEMALES \$2.00; DOUBLE ASSESSMENT MARCH 1, 1950

**RETURN THIS STATEMENT
 WITH YOUR REMITTANCE!**

August 24, 2023

Re: Michigan Community Center Grant Program; Michigan Department of Labor and Economic Opportunity

To Whom It May Concern:

I am writing to share our support for the proposed community center to convert Hazel Park Schools Longfellow Elementary. As a concerned business located at 777 E. Woodward Heights, near the proposed site, that is working to keep older adults engaged and active, we believe that this idea makes sense, particularly considering the aging of the population over the next 25 to 30 years.

We have seen first-hand the sense of belonging and companionship that comes from interacting with peers. With a community center, residents will have the opportunity to participate in activities, events, and classes that cater to diverse interests and needs. Moreover, a community center will foster a strong sense of unity and support within the community. It can serve as a venue for support groups, wellness programs, and educational workshops. These resources will not only address the physical and emotional needs of our residents but also offer guidance and assistance to their families and caregivers. The collaborative atmosphere will encourage residents to share their experiences, wisdom, and talents, thus creating a vibrant and interconnected community.

In addition, the establishment of a community center, near Baldwin House Hazel Park, will give us an opportunity to promote the safe and affordable senior living option that is here in the community. Many residents are not aware of the benefits of our senior living community and the benefits of on-site socialization, access to 3rd party health care, and a micro-mart available 24/7 to access food, snacks, and beverages when they need them. Having this located so close, will clearly benefit our current and future residents.

Michigan Department of Labor
and Economic Opportunity
195 N Michigan Ave
Shelby, MI 49455

Re: Community Center Grant Application

To Whom It May Concern:

On behalf of The Arc of Oakland County, I am reaching out to submit a formal letter of support for the Community Center Grant for which the Hazel Park Schools is applying.

The Arc of Oakland County works to provide expert, individual advocacy and other necessary programs for and on behalf of children and adults with intellectual and developmental disabilities and their families. We count over 2,500 new persons who annually receive our services.

The Arc of Oakland County advocates for the rights and full participation of all children and adults with intellectual and developmental disabilities. We strive to improve systems of supports and services; connect families; inspire our community and influence public policy.

We firmly believe establishing this Community Center at Longfellow Elementary would provide a location for socialization and community engagement, which would be beneficial for the families we serve. The members within our community would have the opportunity to attend a range of activities, events, and classes that cater to their diverse needs and interests. Furthermore, a Community Center will create a space for people with or without disabilities to gather and create a sense of unity while they engage in different programs, workshops, and recreational activities.

In conclusion, I respectfully request consideration for a Community Center at Longfellow Elementary School to improve the lives of the individuals in Oakland County. Thank you very much.

Sincerely,



Community Center

Building Size - SF

33,500

	High Priority	Medium Priority	Low Priority
	666,612	\$ -	\$ -
	2026	2027	2028
	10.00%	21.98%	30.52%
	\$ 66,661	\$ -	\$ -
GRADE COSTS WITH ESCALATION:	\$ 733,053	\$ -	\$ -
	0.50%	3,665	\$ -
CONSTRUCTION SUBTOTALS:	\$ 736,719	\$ -	\$ -
	15.00%	110,508	\$ -
CONSTRUCTION TOTALS:	\$ 847,227	\$ -	\$ -
	0.00%	-	\$ -
TECHNOLOGY SUBTOTAL:	\$ -	\$ -	\$ -
	0.00%	-	\$ -
TECHNOLOGY w/ DESIGN TOTAL:	\$ -	\$ -	\$ -
	LSUM	-	\$ -
	2.00%	16,945	\$ -
	LSUM	-	\$ -
	10.00%	84,723	\$ -
	8.50%	79,216	\$ -

CONSTRUCTION & OWNER COSTS:

\$ 1,028,109

\$ -

\$ -

April 29, 2024

I, Amy Kruppe, hereby certify the information contained in this Michigan Community Center Grant application and support the attached grant application. I am Superintendent/Chief Executive of the City of Hazel Park School District.

Signature:

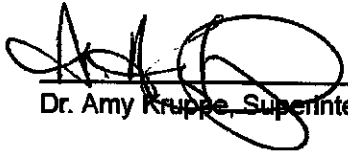

Dr. Amy Kruppe, Superintendent

Date: April 29, 2024



Ford Administration
1620 E. Elza, Hazel Park, MI 48030 | 248-658-5200 | F: 248-544-5443
www.hazelparkschools.org

October 18, 2024

Andrew Carlton
andrew@notionize.org
www.notionize.org

Dear Mr Carlton,

This written notice is a response to your October 18, 2024 email requesting records under the Freedom of Information Act. Pursuant to FOIA MCL 15.234(5), Hazel Park Schools is notifying you that the information sought is available on our public website at <https://www.hazelparkschools.org/our-district/staff-directory/>

Please contact me at your earliest convenience if you should have any questions or concerns.

Respectfully,

James Paterson
FOIA Coordinator

Cc: Jamie Buczko

By: Email



Ford Administration
1620 E. Elza, Hazel Park, MI 48030 | 248-658-5200 | F: 248-544-5223
www.hazelparkschools.org

To: Hazel Park Board of Education
From: Dr. Amy Kruppe
Subject: Door Change Request
Date: November 18, 2024

We are requesting approval for a necessary change order in the ongoing door replacement project funded through the COPS Grant. This change order is required to address compliance issues identified during a recent inspection, which revealed that the originally specified doors do not meet current Fire Marshal Code standards. This adjustment is essential to ensure the safety and regulatory compliance of our facilities.

The original door specifications were selected based on the initial project scope; however, the Fire Marshal's inspection determined that the doors do not meet certain fire resistance and safety criteria. Updating the specifications will enable our facilities to fully comply with fire safety codes, ensuring the protection of the school and its occupants in emergency situations. Fortunately, there is no change in the project timeline with this change, allowing us to maintain our schedule and complete the installation as initially planned.

While this change will incur additional costs, adhering to Fire Marshal requirements is crucial to uphold our high safety standards and avoid potential fines or project delays. With this change order, we will proceed with doors that meet all fire safety regulations and are eligible for continued support under the COPS Grant.

Strategic Goal Alignment - The request for allocating the dollars focuses on the following

- **Resources:** The Hazel Park School District will maximize its resources to assure high quality education by fostering financial stability, preserving and utilizing quality facilities, and integrating state-of-the-art technology.

Funding Source: COPS Grant

Recommendation: We are requesting approval for this change order to meet fire code requirements and proceed with the project in alignment with Fire Marshal guidelines.



AIA® Document G714® – 2017

Construction Change Directive

PROJECT: *(name and address)*
Hazel Park Schools District Wide Door
Assessment PIA #23-119

CONTRACT INFORMATION:
Contract For: General Construction

CCD INFORMATION:
Directive Number: 001

Date:

Date: November 8, 2024

OWNER: *(name and address)*
Hazel Park Schools
1620 East Elza Avenue
Hazel Park, MI 48030-2358

ARCHITECT: *(name and address)*
PARTNERS in Architecture, PLC
65 Market Street
Mount Clemens, MI 48043

CONTRACTOR: *(name and address)*
City Contracting Services, Inc.
1414 N. Campbell Road
Royal Oak, MI 48067

The Contractor is hereby directed to make the following change(s) in this Contract:
(Insert a detailed description of the change and, if applicable, attach or reference specific exhibits.)

Proceed with scope of work as described below:
Work includes but is not limited to:
Refer to Drawings A0-02
Revised ratings of doors as indicated in schedule

All material invoices and time cards will be submitted for record.
Upon completion, a change order will be issued based on final costs.

Attachments - Section 088000, Drawing A0-02

PROPOSED ADJUSTMENTS

- The proposed basis of adjustment to the Contract Sum or Guaranteed Maximum Price is:
 - Lump Sum decrease of \$0.00
 - Unit Price of \$ per
 - Cost, as defined below, plus the following fee:
(Insert a definition of, or method for determining, cost)
 - As follows: As provided in Section 7.3.3 of AIA Document A201-2017

- The Contract Time is proposed to remain unchanged. The proposed adjustment, if any, is (0 days).

NOTE: The Owner, Architect and Contractor should execute a Change Order to supersede this Construction Change Directive to the extent they agree upon adjustments to the Contract Sum, Contract Time, or Guaranteed Maximum price for the change(s) described herein.

When signed by the Owner and Architect and received by the Contractor, this document becomes effective IMMEDIATELY as a Construction Change Directive (CCD), and the Contractor shall proceed with the change(s) described above.

Contractor signature indicates agreement with the proposed adjustments in Contract Sum and Contract Time set forth in this CCD.

PARTNERS in Architecture, PLC
ARCHITECT *(Firm name)*

Hazel Park Schools
OWNER *(Firm name)*

City Contracting Services, Inc.
CONTRACTOR *(Firm name)*

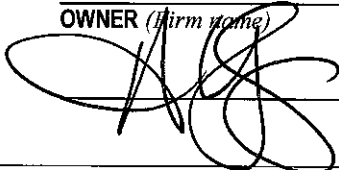

SIGNATURE
Matt Showalter, RA

PRINTED NAME AND TITLE
November 8, 2024

DATE

SIGNATURE
Jason Zirnis, Asst. Superintendent
for Business & Operations

PRINTED NAME AND TITLE

DATE

SIGNATURE
Seth Helfman, President

PRINTED NAME AND TITLE

DATE

SECTION 088000 - GLAZING

PART 1 - GENERAL

1.1 SUMMARY

- A. Section Includes:
 - 1. Glass products.
 - 2. Insulating glass.
 - 3. Glazing sealants.
 - 4. Glazing tapes.
 - 5. Miscellaneous glazing materials.

1.2 COORDINATION

- A. Coordinate glazing channel dimensions to provide necessary bite on glass, minimum edge and face clearances, and adequate sealant thicknesses, with reasonable tolerances to achieve proper safety margins for glazing retention under each design load case, load case combination, and service condition.

1.3 ACTION SUBMITTALS

- A. Product Data: For each type of product.
- B. Glass Samples: For each type of glass product other than clear monolithic vision glass; 12 inches square.
- C. Glazing Schedule: List glass types and thicknesses for each size opening and location. Use same designations indicated on Drawings.

1.4 INFORMATIONAL SUBMITTALS

- A. Preconstruction adhesion and compatibility test report.
- B. Sample warranties.

1.5 QUALITY ASSURANCE

- A. Sealant Testing Agency Qualifications: An independent testing agency qualified according to ASTM C1021 to conduct the testing indicated.

1.6 WARRANTY

- A. Manufacturer's Special Warranty for Insulating Glass: Manufacturer agrees to replace insulating-glass units that deteriorate within specified warranty period. Deterioration of insulating glass is defined as failure of hermetic seal under normal use that is not attributed to glass breakage or to maintaining and cleaning insulating glass contrary to manufacturer's written instructions. Evidence of failure is obstruction of vision by dust, moisture, or film on interior surfaces of glass.

1. Warranty Period: 10 years from date of Substantial Completion.

PART 2 - PRODUCTS

- A. Fire Rated Glazing Basis-of-Design Product: Subject to compliance with requirements, provide Technical Glass Products or comparable product by one of the following:

1. Safety and Fire Technology Inc. (SAFTIFIRST).
2. McGrory Glass.
3. Pilkington North America.

2.2 GLASS PRODUCTS, GENERAL

- A. Glazing Publications: Comply with published recommendations of glass product manufacturers and organizations below unless more stringent requirements are indicated. See these publications for glazing terms not otherwise defined in this Section or in referenced standards.
1. NGA Publications: "Laminated Glazing Reference Manual" and "Glazing Manual."
 2. IGMA Publication for Insulating Glass: SIGMA TM-3000, "North American Glazing Guidelines for Sealed Insulating Glass Units for Commercial and Residential Use."
- B. Safety Glazing Labeling: Where safety glazing is indicated, permanently mark glazing with certification label of the SGCC or another certification agency acceptable to authorities having jurisdiction. Label shall indicate manufacturer's name, type of glass, thickness, and safety glazing standard with which glass complies.
- C. Insulating-Glass Certification Program: Permanently marked either on spacers or on at least one component lite of units with appropriate certification label of the IGCC.
- D. Thickness: Where glass thickness is indicated, it is a minimum. Provide glass that complies with performance requirements and is not less than thickness indicated.
- E. Strength: Where annealed float glass is indicated, provide annealed float glass, heat-strengthened float glass, or fully tempered float glass. Where heat-strengthened float glass is indicated, provide heat-strengthened float glass or fully tempered float glass. Where fully tempered float glass is indicated, provide fully tempered float glass.

2.3 GLASS PRODUCTS

- A. Clear Annealed Float Glass: ASTM C1036, Type I, Class 1 (clear), Quality-Q3.

- B. Fully Tempered Float Glass: ASTM C1048, Kind FT (fully tempered), Condition A (uncoated) unless otherwise indicated, Type I, Class 1 (clear) or Class 2 (tinted) as indicated, Quality-Q3.

2.4 GLAZING SEALANTS

A. General:

1. Compatibility: Compatible with one another and with other materials they contact, including glass products, seals of insulating-glass units, and glazing channel substrates, under conditions of service and application, as demonstrated by sealant manufacturer based on testing and field experience.
2. Suitability: Comply with sealant and glass manufacturers' written instructions for selecting glazing sealants suitable for applications indicated and for conditions existing at time of installation.
3. Colors of Exposed Glazing Sealants: As selected by Architect from manufacturer's full range of industry colors.

2.5 GLAZING TAPES

- A. Back-Bedding Mastic Glazing Tapes: Preformed, butyl-based, 100 percent solids elastomeric tape; nonstaining and nonmigrating in contact with nonporous surfaces; with or without spacer rod as recommended in writing by tape and glass manufacturers for application indicated; and complying with ASTM C1281 and AAMA 800 for products indicated below:

1. AAMA 804.3 tape, where indicated.

- B. Expanded Cellular Glazing Tapes: Closed-cell, PVC foam tapes; factory coated with adhesive on both surfaces; and complying with AAMA 800 for the following types:

1. AAMA 810.1, Type 1, for glazing applications in which tape acts as primary sealant.

2.6 MISCELLANEOUS GLAZING MATERIALS

- A. Cleaners, Primers, and Sealers: Types recommended by sealant or gasket manufacturer.

B. Setting Blocks:

1. Elastomeric material with Shore A durometer hardness of 85, plus or minus 5.

C. Edge Blocks:

1. Elastomeric material with Shore A durometer hardness per manufacturer's written instructions.
2. Type recommended in writing by sealant or glass manufacturer.

- D. Cylindrical Glazing Sealant Backing: ASTM C1330, Type O (open-cell material), of size and density to control glazing sealant depth and otherwise produce optimum glazing sealant performance.

PART 3 - EXECUTION

3.1 GLAZING, GENERAL

- A. Comply with combined written instructions of manufacturers of glass, sealants, gaskets, and other glazing materials, unless more stringent requirements are indicated, including those in referenced glazing publications.
- B. Protect glass edges from damage during handling and installation. Remove damaged glass from Project site and legally dispose of off Project site. Damaged glass includes glass with edge damage or other imperfections that, when installed, could weaken glass, impair performance, or impair appearance.
- C. Apply primers to joint surfaces where required for adhesion of sealants, as determined by preconstruction testing.
- D. Install setting blocks in sill rabbets, sized and located to comply with referenced glazing publications, unless otherwise required by glass manufacturer. Set blocks in thin course of compatible sealant suitable for heel bead.
- E. Do not exceed edge pressures stipulated by glass manufacturers for installing glass lites.
- F. Provide spacers for glass lites where length plus width is larger than 50 inches.
- G. Provide edge blocking where indicated or needed to prevent glass lites from moving sideways in glazing channel, as recommended in writing by glass manufacturer and in accordance with requirements in referenced glazing publications.

3.2 TAPE GLAZING

- A. Position tapes on fixed stops so that, when compressed by glass, their exposed edges are flush with or protrude slightly above sightline of stops.
- B. Install tapes continuously, but not necessarily in one continuous length. Do not stretch tapes to make them fit opening.
- C. Cover vertical framing joints by applying tapes to heads and sills first, then to jambs. Cover horizontal framing joints by applying tapes to jambs, then to heads and sills.
- D. Place joints in tapes at corners of opening with adjoining lengths butted together, not lapped. Seal joints in tapes with compatible sealant approved by tape manufacturer.
- E. Apply heel bead of elastomeric sealant.
- F. Center glass lites in openings on setting blocks, and press firmly against tape by inserting dense compression gaskets formed and installed to lock in place against faces of removable stops. Start gasket applications at corners and work toward centers of openings.
- G. Apply cap bead of elastomeric sealant over exposed edge of tape.

PARTNERS 23-119
GLAZING
088000-6

- 2) Interlayer Color: Clear
- e. Inner Lite: Class 1 (clear) float glass
 - 1) Thickness: 1/8 inch

3.6 LAMINATED SECURITY GLASS SCHEDULE

A. Glass Type (LSG-10): Laminated security glass.

- 1. Basis-of-Design Product: LTI Smart Glass, Inc. "School Guard SG4".
 - a. Nominal Thickness: 1/4 inch.
 - b. Refer to Alternates section and Unit Price section for locations

3.7 FIRE RATED GLASS SCHEDULE

A. Fire Glass Units – 20 Minutes (FG-10):

- 1. "Fire Glass 20" as supplied by Technical Glass Products; or "SuperLite I" by SaffiFirst or approved equal.
 - a. Impact safety rated. Complies with ANSI Z97.1 and CPSC 16CFR1201 (Cat I & II).
 - b. Provide at locations with Fire Rating: 20 minutes as indicated.
 - c. Thickness: 1/4"

B. Fire Glass Units – 45 Minutes (FG-11):

- 1. "Superlite X 45" as supplied by SaffiFirst or approved equal by TGP.
 - a. Impact safety rated. Complies with CPSC 16CFR1201 (Cat I & II).
 - b. Provide at locations with Fire Rating: 45 minutes as indicated.
 - c. Thickness: 3/4"

END OF SECTION 088000

3.3 GASKET GLAZING (DRY)

- A. Cut compression gaskets to lengths recommended by gasket manufacturer to fit openings exactly, with allowance for stretch during installation.
- B. Insert soft compression gasket between glass and frame or fixed stop so it is securely in place with joints miter cut and bonded together at corners.
- C. Installation with Drive-in Wedge Gaskets: Center glass lites in openings on setting blocks, and press firmly against soft compression gasket by inserting dense compression gaskets formed and installed to lock in place against faces of removable stops. Start gasket applications at corners and work toward centers of openings. Compress gaskets to produce a weathertight seal without developing bending stresses in glass. Seal gasket joints with sealant recommended in writing by gasket manufacturer.
- D. Installation with Pressure-Glazing Stops: Center glass lites in openings on setting blocks, and press firmly against soft compression gasket. Install dense compression gaskets and pressure-glazing stops, applying pressure uniformly to compression gaskets. Compress gaskets to produce a weathertight seal without developing bending stresses in glass. Seal gasket joints with sealant recommended in writing by gasket manufacturer.
- E. Install gaskets so they protrude past face of glazing stops.

3.4 CLEANING AND PROTECTION

- A. Immediately after installation, remove nonpermanent labels and clean surfaces.
- B. Protect glass from contact with contaminating substances resulting from construction operations. Examine glass surfaces adjacent to or below exterior concrete and other masonry surfaces at frequent intervals during construction, but not less than once a month, for buildup of dirt, scum, alkaline deposits, or stains.
 - 1. If, despite such protection, contaminating substances do contact with glass, remove substances immediately as recommended in writing by glass manufacturer. Remove and replace glass that cannot be cleaned without damage to coatings.
- C. Remove and replace glass that is damaged during construction period.

3.5 LAMINATED GLASS SCHEDULE

- A. Glass Type (LG-10): Clear laminated annealed or heat-strengthened float glass.
 - 1. Minimum Thickness: ¼ inch (6 mm).
 - a. Provide at clear laminated safety glass at all non fire rated doors.
 - b. Kind LA, consisting of two lites of annealed float glass
 - c. Outer Lite: Class 1 (clear) float glass
 - 1) Thickness: 1/8 inch
 - d. Plastic Interlayer
 - 1) Thickness: 0.030 inch, but not less than that required to comply as a type II safety glass material.



Partners in Architecture, P.C.
10000 Park Road, Suite 100
Dallas, Texas 75244
Phone: 972.383.8800
Fax: 972.383.8801

OWNER:
Hazel Park Schools

PROJECT NAME:
District Wide Door Assessment High School

PROJECT NO:
23-119

DATE:
04-17-2024

BY:
J. Blanton

DATE:
11-05-2024

PROJECT NO:
23-119

PROJECT NAME:
District Wide Door Assessment High School

SHEET NO:
AO-02

Table with columns: Door / Opening Schedule, Location, Size, Material, Frame, Type, etc.

Table with columns: Material, Size, Frame, Type, etc.

Table with columns: Material, Size, Frame, Type, etc.

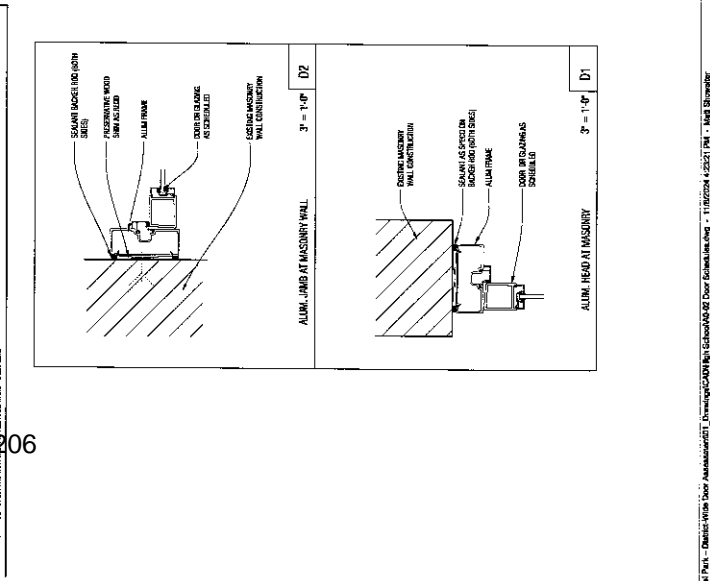



Ford Administration
1620 E. Elza, Hazel Park, MI 48030 | 248-658-5200 | F: 248-544-5223
www.hazelparkschools.org

To: Hazel Park Board of Education
From: Dr. Amy Kruppe
Subject: Approval Request for Basketball Backstops
Date: November 18, 2024

We are proposing the installation of two ceiling-suspended, retractable basketball backstops to enhance the functionality and quality of our sports facilities. This project includes professional installation of high-durability backstops equipped with advanced control features and safety enhancements designed for long-term, reliable use.

Currently, our high school supports five basketball teams—three boys' teams and two girls' teams. The previous backboards were removed during the recent bleacher installation, limiting practice space for all teams. Reinstalling these backstops will provide the essential facilities our teams need to practice and compete effectively.

Total Cost: \$17,320.00

Strategic Goal Alignment - The request for allocating the dollars focuses on the following

Community Relations: The Hazel Park School District through strong community relations and collaboration with all stakeholders will develop high-achieving students.

Climate and Culture: The Hazel Park School District will provide a unified system of support for all students, embracing diversity, and fostering a positive school climate.

Funding Source: General Fund

Recommendation: That the Board approve the purchase and installation of two Basketball Backdrops not to exceed \$17,320.00, as presented.

**APPROVED AND RECOMMENDED FOR
BOARD ACTION**

Amy Y. Kruppe, Ed.D.
Superintendent



Carter Crompton, Inc.
5090 W. Frances Rd
Clio, MI 48420

PROPOSAL

Date: 11-7-24

Prepared for: Hazel Park High School
23400 Hughes Ave.
Hazel Park, MI 48030

Attention: Mr. CJ Goff cgoff22@yahoo.com
P# 586-801-2920

Project: **(2) Ceiling suspended retractable basketball backstops.**

Description:

1. (20) H-D Compression beam clamps.
2. (4) Support bridges 24'.
3. (2) 23' Sub-frame pipes.
4. (6) Support drop hangers.
5. (4) 9' Header pipes.
6. (8) 4-Ways.
7. (2) H-D Ceiling suspended retractable mono post mainframes. 25 Yr. warranty
8. (2) Knee braces.
9. (2) 120V Gear driven electric hoist. 5 Yr. warranty
10. (2) Momentary key switches.
11. Preset limit switches.
12. (2) Auto-locks. (safety straps) 5 Yr. warranty
13. (2) 42" x 72" Glass backboards. Limited lifetime warranty
14. (2) 2000+ Breakaway rims. 4 Yr. warranty
15. (2) PMCE Bolt on backboard edge padding. 5 Yr. warranty
16. Delivered and installed.

Total cost: \$ 17,320.00

NOTE: All electrical work to be done by others.

Thank you for the opportunity to submit this proposal, we appreciate your consideration.

TERMS: 50% Deposit with the order, balance due day of completion.

VALID: 30 Days.

Carter Jr. C# 810-577-7099

WINCH-QR4 110V 60HZ single phase Motorized Basketball Backstop Winch

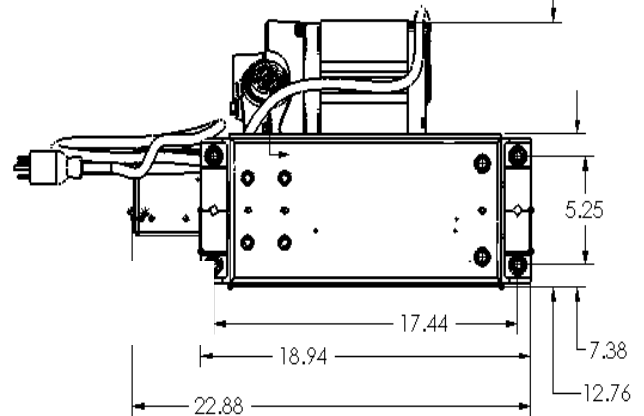
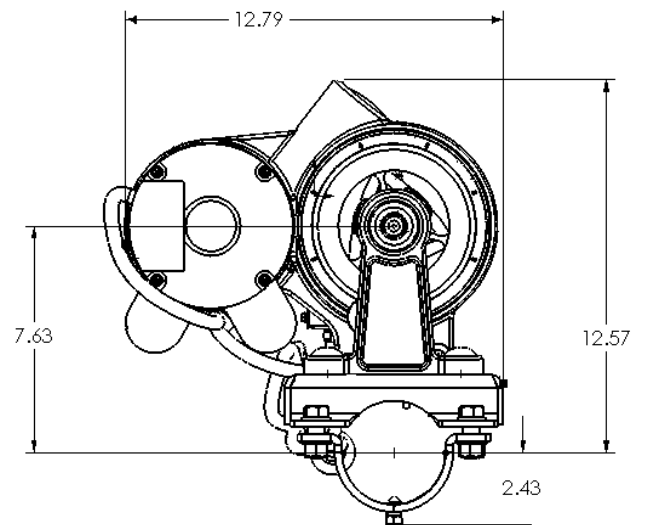
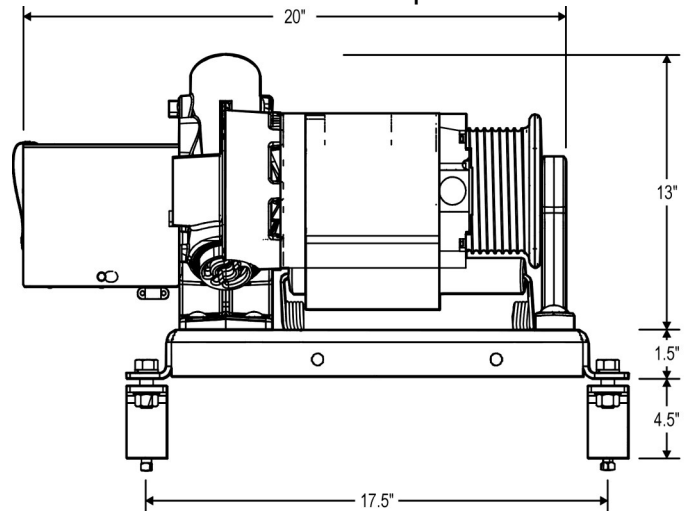
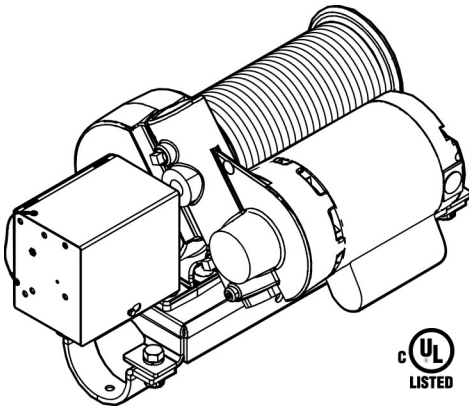

Part Number: WINCH-QR4-220V-60HZ-1PH
Lifting Capacity: 1250 Lbs / 566 Kg
Lifting Speed: 9.6 feet per minute
Motor: 3/4 Horse Power, 220v 60 HZ, single phase
POWER: 5.6 AMPS
Duty Intermittent; 10 Minutes Per Hour
Cable Drum Diameter: 4.5 Inch / 11.5 Cm
Cable Drum Capacity: 35 feet/12 Meters capacity on first layer ¼ Inch / .64 Cm Aircraft Cable (Cable not supplied)
Gear Case: Double Reduction Lifetime Sealed Oil Bath. Precision machined positive locking direct drive with all metal gears and precision sealed ball bearings
Limit Switch: Gear driven direct drive limit switch with upper and lower settings. Positive locking for accuracy.
 Wire Lanyard prevents control cover from falling
Mounting: Pipe, Wall or Truss mount capable
Weight: 78 Lbs / 35 Kilograms



LynRus Gymnasium Products
 204 West 1700 South
 Salt Lake City, Utah, 84115
www.lynrus.com
 801-486-8104

Specifications—Winch-QR4

Winch shall be rated to deliver 1250lbs/ 566kgs of vertical lifting at a line speed of 9.6 feet/2.75 meters per minute. Available cable travel shall be 32 feet/9.75 meters on one layer. Cable drum shall be manufactured from T6 heat treated aluminum alloy and shall be fully supported for maximum strength. The drum shall be helically grooved for 1/4" 7 x 19 aircraft cable. Grooving shall provide proper spooling of the cable and ensure excellent repeatability of stop positions. Drum shall be equipped with a spring tensioned pressure roller to ensure cable tracking under slack cable conditions. Winch shall be a universal mount with a 360 degree rotation allowing multiple cable routes. Winch shall employ an inherently self locking double reduction worm drive. Gearbox shall be a precision machined using only metal components for maximum gear life. The gear box shall be fully sealed and shall not require any additional lubrication for the life of the unit. Winch shall have direct drive user adjustable limit switch for up and down travel positions. Winch shall be driven by 3/4 HP, instantly reversing, 110V single-phase electric motor utilizing a 3-wire control system. Motor shall have an automatic reset overload protection, and shall draw 11.5 full load amps. Winch shall be C UL Rated

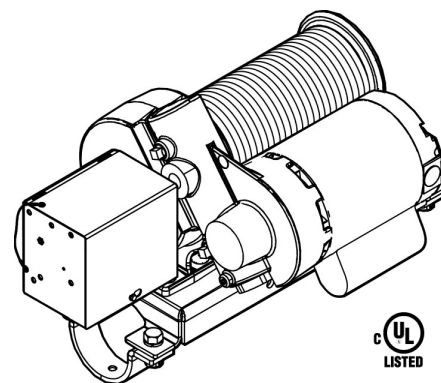

Options:

3 Position Key Switch. For secure and direct operation.

Power Wireless Remote Control. For remote control operation of electric winch.

Key switch to receptacle wiring

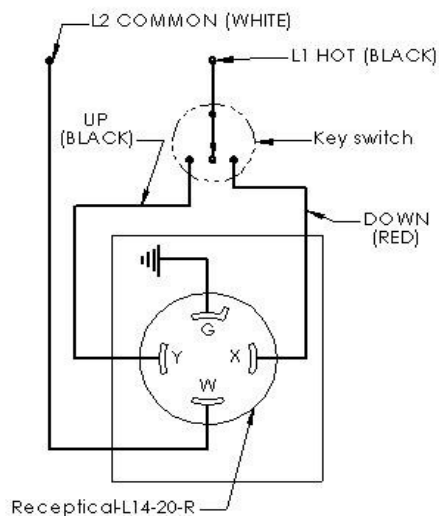

Wiring with pigtail

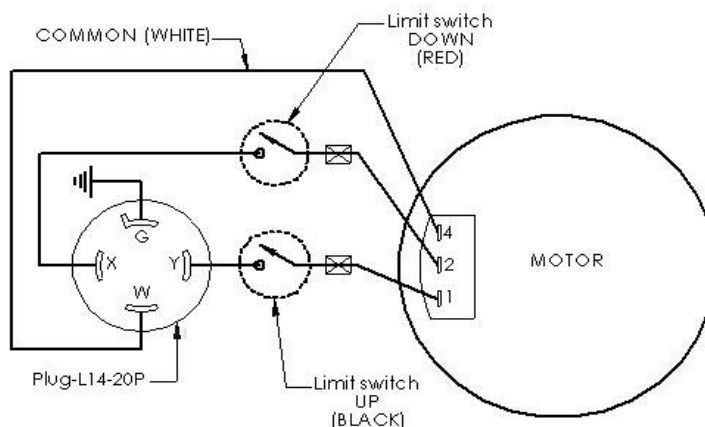

LynRus Aluminum Products - 204 West 1700 South
Salt Lake City, Utah, 84115 - www.lynrus.com - 801-486-8104

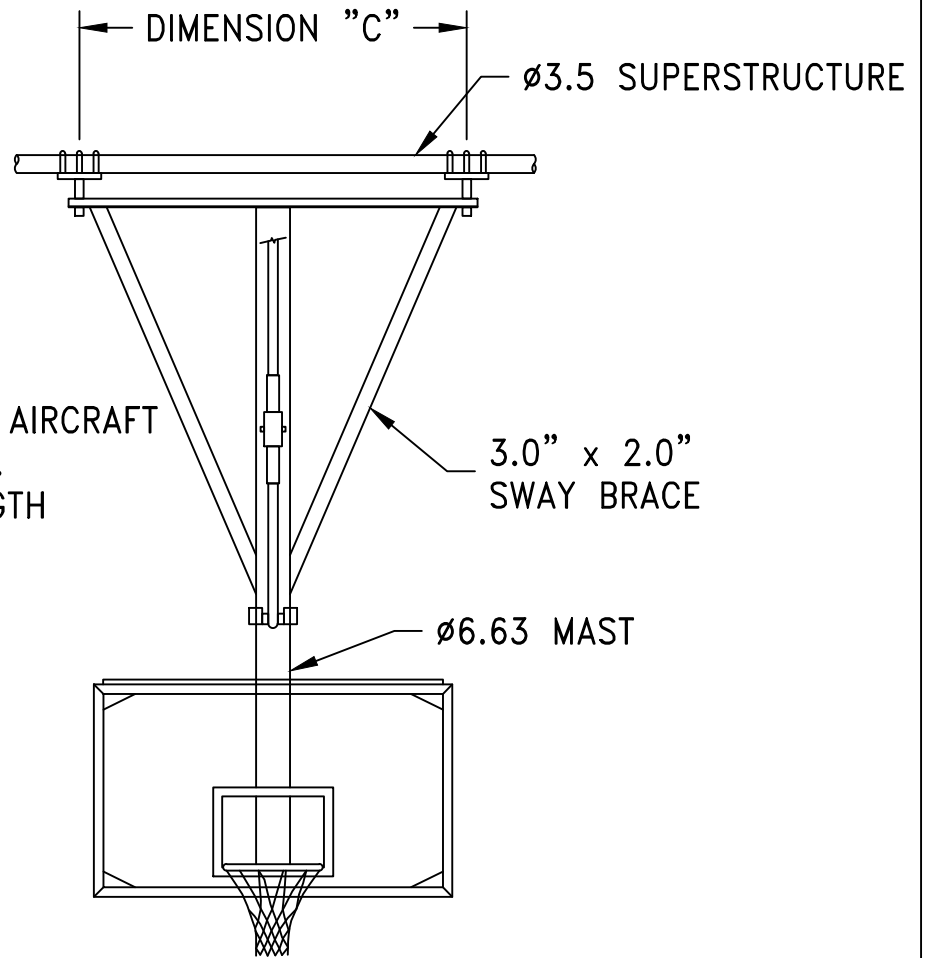
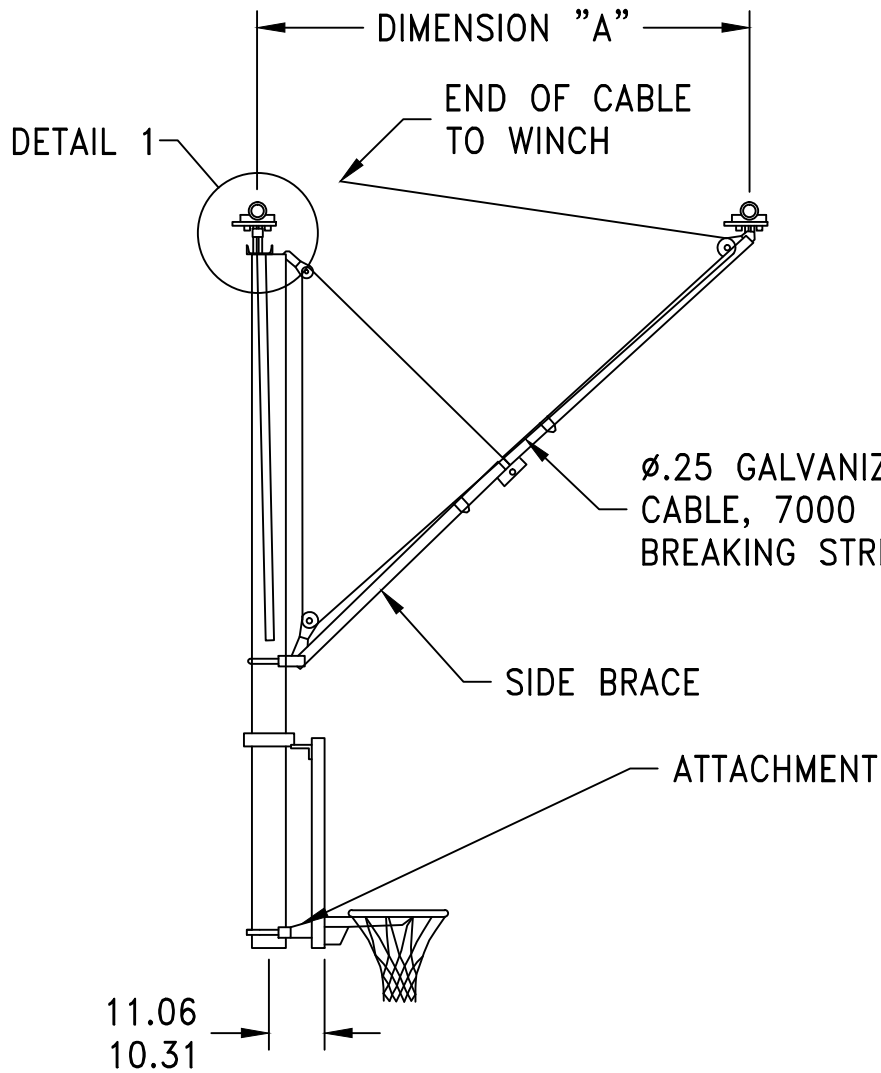



Ford Administration
1620 E. Elza, Hazel Park, MI 48030 | 248-658-5200 | F: 248-544-5223
www.hazelparkschools.org

To: Board of Education
From: Dr. Amy Kruppe, Superintendent
Subject: Review of Facility Usage Agreement
Date: November 18, 2024

Per the Board's request to review our current Facility Usage Agreement. It was suggested that we incorporate a structured fee to support the costs associated with maintenance, utilities, and staffing required to accommodate external events.

The Board feels the adjustment would allow us to manage facility usage more sustainably, offsetting wear and tear on our buildings and grounds, offsetting funds to pay for required staffing and ensuring availability for district needs.

Funding Sources: N/A

Strategic Goal Alignment:

Resources: The Hazel Park School District will maximize its resources to assure high quality education by fostering financial stability, preserving and utilizing quality facilities, and integrating state-of-the-art technology.

Community Relations: The Hazel Park School District through strong community relations and collaboration with all stakeholders will develop high-achieving students.

Recommendation

That the Board of Education approve the review of the Facility Usage Agreement and the proposed charge for outside organizations.

**APPROVED AND RECOMMENDED FOR
BOARD ACTION**

Amy Y. Kruppe, Ed.D.
Superintendent



**Hazel Park Schools
Building Rental Guidelines/ Costs**

The Board of Education recognizes the importance of community engagement and permits the reasonable use of its buildings and grounds by responsible community groups. This section outlines the classifications of users, the application process, regulations, fees, and other important details related to the use of District facilities.

The use of District facilities is classified into four categories:

- Class I – School Groups: Groups affiliated with the District's educational mission.
- Class II – Youth Groups: Non-District youth-oriented groups.
- Class III – Other Non-Profit Community Groups: Community-based, non-profit organizations.
- Class IV – Other Groups: Includes profit-making organizations and other groups approved by the Superintendent.

To utilize District facilities, groups must adhere to a straightforward process. Initially, they submit an application for facility use to on the school district website. Following approval, the application advances for final approval to the district. Upon successful review, approved applications result in the issuance of a permit, granting permission for the requested facility use. This systematic approach ensures transparency, accountability, and the efficient allocation of District resources for community engagement.

Fees are determined by the Superintendent and may vary based on the classification of the user group.

Waivers may be eligible for fee waivers or reduced charges at the discretion of the Superintendent.

Permit holders shoulder several critical responsibilities when using District facilities. They must supervise activities diligently to ensure the safety of participants and prevent any potential injuries or damages. Additionally, holders are required to indemnify the District against any liabilities or costs that may arise during the use of the facilities. Obtaining liability insurance coverage as mandated by the District is also a crucial requirement to mitigate risks effectively. Depending on the nature of the event, additional security measures may be necessary, and the associated costs are borne by the user. Furthermore, understanding the cancellation terms and conditions, including advance notice requirements and specific circumstances, is essential for permit holders. Moreover, any decorations used must receive prior approval and must comply with legal standards to maintain the integrity of District property.

Certain additional guidelines must be strictly adhered to when using District facilities. Proper licensing is mandatory for any food service activities, and the public sale of

materials is strictly prohibited on school premises. Furthermore, alcohol consumption and smoking are strictly forbidden to uphold a safe and healthy environment for all. The use of District equipment and supplies is limited and must be approved in advance to ensure responsible utilization. Lastly, facility usage hours are determined based on the school schedule and specific usage hours to align with the District's operational needs and priorities. These guidelines collectively contribute to the safe, organized, and efficient utilization of District facilities.

The costs for renting various District facilities depend on factors such as the classification of the user group and the specific space needed. For detailed information on hourly rates, please refer to the attached rental space chart. This chart provides a comprehensive breakdown of the costs associated with renting different types of facilities within the District, helping users make informed decisions regarding their budget and space requirements.

In addition to facility rental fees, custodial services are available at an extra cost per hour per person. The cost and need of custodial services vary based on the classification of the user group. These services ensure that the facilities are maintained in a clean and orderly manner before, during, and after use, contributing to a positive experience for all users.

We are implementing a new charge for mandated security during facility rentals. For indoor activities, a security fee of \$25 per hour will be assessed. This charge will cover the cost associated with having a staff member stationed at the entry doors to monitor and maintain secure access throughout the event.

For requests involving areas not listed in the rental space chart or specific services not mentioned, individuals or groups are encouraged to reach out to the appropriate District representative. These requests will be carefully considered and evaluated for feasibility and approval. Direct communication with District representatives allows for tailored solutions and ensures that all user needs are addressed effectively and efficiently.

The guidelines outlined here govern the use of District facilities, ensuring responsible and productive community engagement. This includes permitting the reasonable use of buildings and grounds by responsible community groups, with the condition that such use does not disrupt daily school activities or jeopardize the condition of District facilities. Approval for rental or use of District facilities must be obtained in advance from the Superintendent or designated authority. Additionally, the Superintendent issues administrative guidelines that further regulate the use and rental processes for District facilities, prioritizing the District's educational mission and the well-being of its students and staff.

The Board of Education upholds a policy that allows for the reasonable utilization of its buildings and grounds, referred to as "facilities," by well-organized and responsible community groups. While these facilities are primarily intended for educational purposes and are funded by taxpayers for such use, they may also serve the broader community for activities that enhance educational, recreational, cultural, and civic endeavors for children and the community at large. The allocation of facility usage prioritizes the school program as the first priority, with other uses categorized into four classes. Within each class, facilities are made accessible on a non-discriminatory basis, ensuring fair and equitable access for all user groups.

A. Class I — School Groups

This classification includes groups whose membership and sponsor are members of the student body, District staff, community education, parent groups sponsored by the school, and/or recognized bargaining units representing District employees, or which have been approved by the Superintendent as supporting the educational needs of or promoting readiness for students potentially entering the District.

B. Class II — Youth Groups

This classification includes groups not affiliated with or sponsored by the District, but which are youth-oriented and whose membership thus largely consists of District students or youth who reside in the District. Examples include the Boy Scouts and Girl Scouts, the Little League or other youth athletic organizations.

C. Class III — Other Non-Profit Community Groups

This classification includes not-for-profit groups whose membership largely consists of members of the community who are not students of the District or who reside in the District. Examples include civic organizations, local government agencies, and other recreational activities.

D. Class IV - Other Groups

Other groups, including profit-making organizations, will be permitted to use District facilities when the anticipated use is not harmful to the public image of the District, as determined by the Superintendent or designee in his or her discretion, and will not result in misuse, overuse, or abuse of school property.

General Regulations

To maintain a smooth school day and activities, District facilities are open to Classes II, III, and IV groups at least fifteen (15) minutes after school ends or on non-school days

like weekends. However, government units can use facilities during school hours for Federal, State, or local elections.

Using District facilities incurs fees set by the Superintendent. Class I or II groups may receive fee waivers or reductions as decided by the Superintendent or designee.

Before conducting any activities in District facilities, groups must submit an application for approval by District representatives. Applications follow a District-provided form which can be accessed on the website facility availability confirmation. You can submit a facility usage request using our scheduling platform FMX found both on our website and here: <https://myhpsd.gofmx.com/scheduling/requests/new> Upon availability approval, they proceed to the district for final clearance. The District retains the right to reject applications from groups with groups for the following reason, including but not limited to a history of property damage, violation of usage permits, regulations or laws. An approved application serves as a permit. However, permit holders can't deviate from permit terms unless:

1. Unforeseen circumstances require the school to use a permitted facility or maintenance work is needed to continue normal school operations. In such cases, the District may cancel the permit and return fees to the permit holder.
2. An organization with a permit can cancel its use by notifying the District in writing at least ten (10) calendar days before the scheduled time. Fees are refunded if cancellation occurs more than ten (10) days before the scheduled use; otherwise, the permit holder is responsible for the full fees.

The following terms and conditions are incorporated into each application and permit:

1. The permit holder is responsible for supervising the activities of persons using the facility for which it has obtained a permit and shall take reasonable steps to prevent injuries or damage to persons and property.
2. The District shall be fully released from and indemnified against any and all liability and costs whatsoever to persons or property for injuries or damages resulting from the use of the facilities described in the permit or any other use to which the permit holder puts the facility.
3. The permit holder will reimburse the District for the full cost of repairing any damage, over and above ordinary wear, to the facility during the permit holder's use of the facility, including damage caused by any member of the public.
4. **Liability insurance coverage, shall be obtained at the user's cost and be in the amount of \$2 million dollars.** Such insurance shall be in a form acceptable to District administrators, and a certificate of insurance coverage shall be furnished to the District before use of the facilities. The user shall provide a reasonable security deposit and/or security measures (including, without limitation, security personnel) as directed, at the user's cost.
5. The District shall be fully indemnified and released from any claim asserted by a municipality for reimbursement of additional expense for fire and/or police protection resulting from the use of a facility by an organization or individual.
6. No permit holder shall assign or sublease its permit.

7. Permit holders shall not use a District facility as their mailing address.
8. The permit holder shall indicate in all literature and other promotional materials in connection with the event to which the permit applies that the permit holder is not affiliated with the District and shall not use an image or the name of the District or facility in materials promoting the event to which the permit applies.

Permits granting use of a facility expire with the close of the school year on June 30. Annual, seasonal, and extended time use applications should be submitted at least two (2) months before the proposed starting date of the use. The District reserves the right to use, for any purpose, any portion of a facility not specifically reserved by the permit at the same time the permit is in effect.

A permit holder shall not serve food during an event unless proper licensing has been secured from the Oakland County Department of Health and approved by the district. The public sale of materials, except as incidental to the program for which a permit has been issued, is prohibited on District premises. The District reserves the right to utilize its in house provider for food services

The District representative must approve any decorations erected in connection with a permitted use. Any such decorations must also satisfy any legal requirements of the State of Michigan and local municipalities. Approved decorations must be erected so as not to damage or destroy District property. Decorations shall be removed from the facility by the permit holder before 8:00 a.m. on the day after the use.

With respect to fire prevention and safety, smoking on school property is prohibited. The use of open flames at a District facility, except as part of the school curriculum, is prohibited. Exits and corridors must be kept free of obstructions to ingress and egress.

The possession or use of alcoholic beverages on school property is prohibited.

Permit holders shall not use District supplies or materials. Permit holders' supplies and materials may be stored in a District building only with the permission of the building administrator.

Permit holders may use District equipment only if and to the extent stated in the permit.

Appropriate shoes must be worn by participants using gymnasium floors.

NO animals (unless approved by the administration) shall be allowed on the school ground or in the facilities included by not limited to the athletic stadiums.

No bikes, scooters, skateboards or strollers are allowed on the track or football field.

A use permit is subject to immediate cancellation if these regulations or any other requirements imposed by the District are not followed or if there is a violation of the law while District facilities are being used. Violations of the procedures may lead to an organization forfeiting the ability to rent or use the facilities with the school district in the future.

I agree to the terms and conditions set above.

[Individual Representing]
[Name of Outside Group]

Date

Those wishing to use Camp Hazelwood should contact ryann.voss@myhpsd.org .
Discounts for daily or week usage may be available.

<u>Rental Space</u>	<u>Class I: School Groups</u>	<u>Class II: Youth Groups</u>	<u>Class III: Other Non-Profit Groups (Per hour costs)</u>	<u>Class IV: Other Groups (Per hour costs)</u>	<u>Deposit due one week after permit approval</u>
Classroom	\$0	\$0	\$10	\$20	\$100
Media Center	\$0	\$0	\$15	\$30	\$100
Cafeteria	\$0	\$0	\$15	\$30	\$100
Large Gym (HS)	\$0	\$0	\$40	\$80	\$200
Aux. Gym HS	\$0	\$0	\$30	\$60	\$200
MS Gym	\$0	\$0	\$30	\$60	\$200
Elementary Gym	\$0	\$0	\$25	\$50	\$200
HS pools w/o lifeguards	\$0	\$0	\$40	\$80	\$200
HS pool with lifeguards	\$0	\$35 per lifeguards	\$75 with one lifeguard +\$35 for each after	\$110 with one lifeguard +\$35 for each after	\$200
Football field	\$0	\$0	\$175 an hour	\$250 an hour	\$500
Turf practice field	\$0	\$0	\$125 an hour	\$200 an hour	\$500
Other fields	\$0	\$0	\$75 a game	\$125 a game	\$200
Board room	\$0	\$0	\$50 an hour	\$75 an hour	\$100
Camp Hazelwood	\$0	\$0	\$75 an hour	\$100 an hour	\$250
Auditorium High School	\$0	\$0	\$80 an hour	\$100 an hour	\$200
Auditorium Junior High	\$0	\$0	\$60 an hour	\$80 an hour	\$160
Custodial per person	\$0	\$0	\$50 an hour	\$75 an hour	
Security Indoor Events	\$0	\$0	\$25 an hour	\$25 an hour	\$50
Other areas upon request					



Ford Administration
1620 E. Elza, Hazel Park, MI 48030 | 248-658-5200 | F: 248-544-5223
www.hazelparkschools.org

To: Hazel Park Board of Education
From: Dr. Amy Kruppe, Superintendent
Date: November 18, 2024
Re: HPJH Washington DC Trip

Thank you for your support of last year's successful 8th-grade Washington, D.C. trip. The positive response from students and families, along with the valuable educational experiences, has led us to request approval for this year's trip from May 6–9, 2025.

The cost for each student is \$874, covering transportation, lodging, meals, attractions, guided tours, and medical coverage. Informational meetings in 2024 provided families ample time for payment plans, and we are seeking community support to offer scholarships where needed.

The agenda includes key historic sites like the White House, Arlington Cemetery, and various national memorials, plus educational experiences in the National Zoo and several museums.

For those unable to attend, a 4-day Virtual Washington, D.C. Trip will be offered, engaging students in Washington-focused digital activities to ensure an inclusive experience for all.

Strategic Goal Alignment

Curriculum & Instruction: Hazel Park Schools will develop innovative, independent and persistent learners who think critically, communicate effectively, and positively influence the local and global community.

Climate and Culture: The Hazel Park School District will provide a unified system of support for all students, embracing diversity, and fostering a positive school climate.

Recommendation

That the Board of Education approve the overnight trip for Hazel Park Junior High's 8th grade class, as presented.

**APPROVED AND RECOMMENDED FOR
BOARD ACTION**

Amy Y. Kruppe, Ed.D.
Superintendent



The reviews are in—you can expect
life-changing moments ahead

Washington, D.C. Trip Meeting



224



WorldStrides[®]

Educational Travel & Experiences



In this meeting...

- 01 Our Trip** and all that we're going to see and do
- 02 What's Included** in our travel program
- 03 Our Travel Partner** WorldStrides and why we are so excited to work with them
- 04 How to Sign Up** for this incredible opportunity

225



Arlington National Cemetery



Tomb of the Fallen Soldier



Marine Corps Memorial ²²⁶

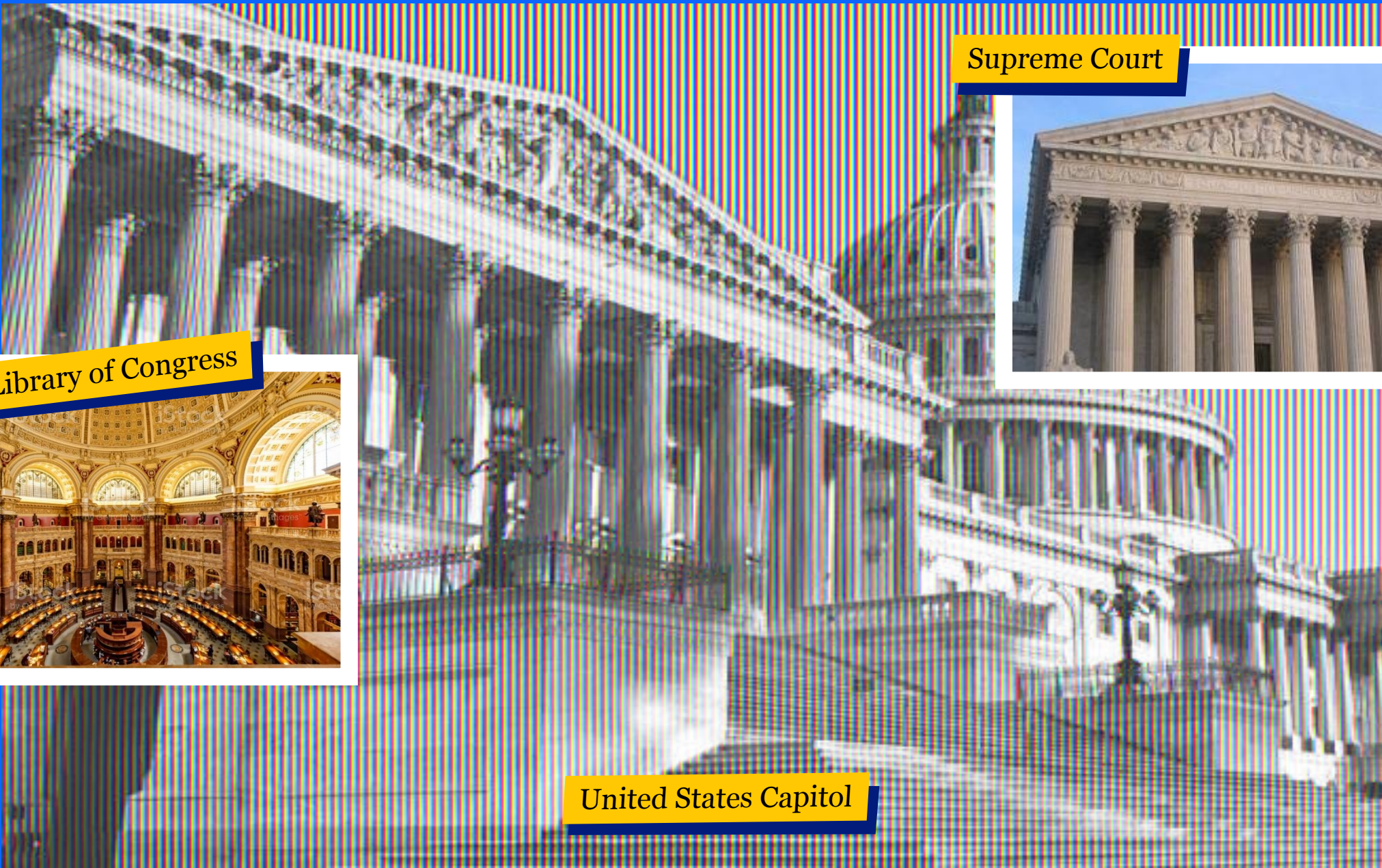

Supreme Court



Library of Congress

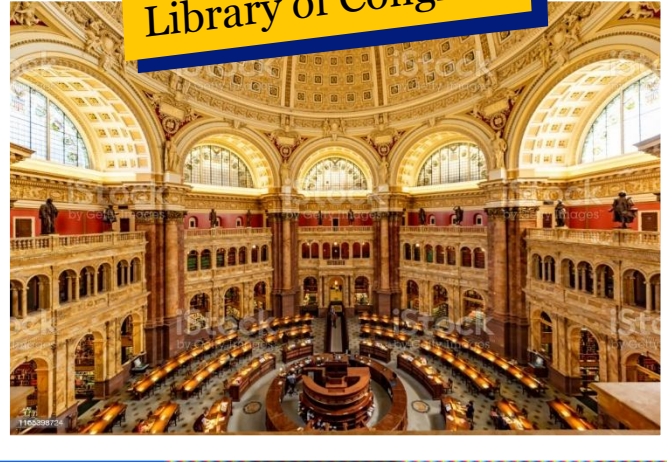

United States Capitol

227



Jefferson Memorial



Lincoln Memorial

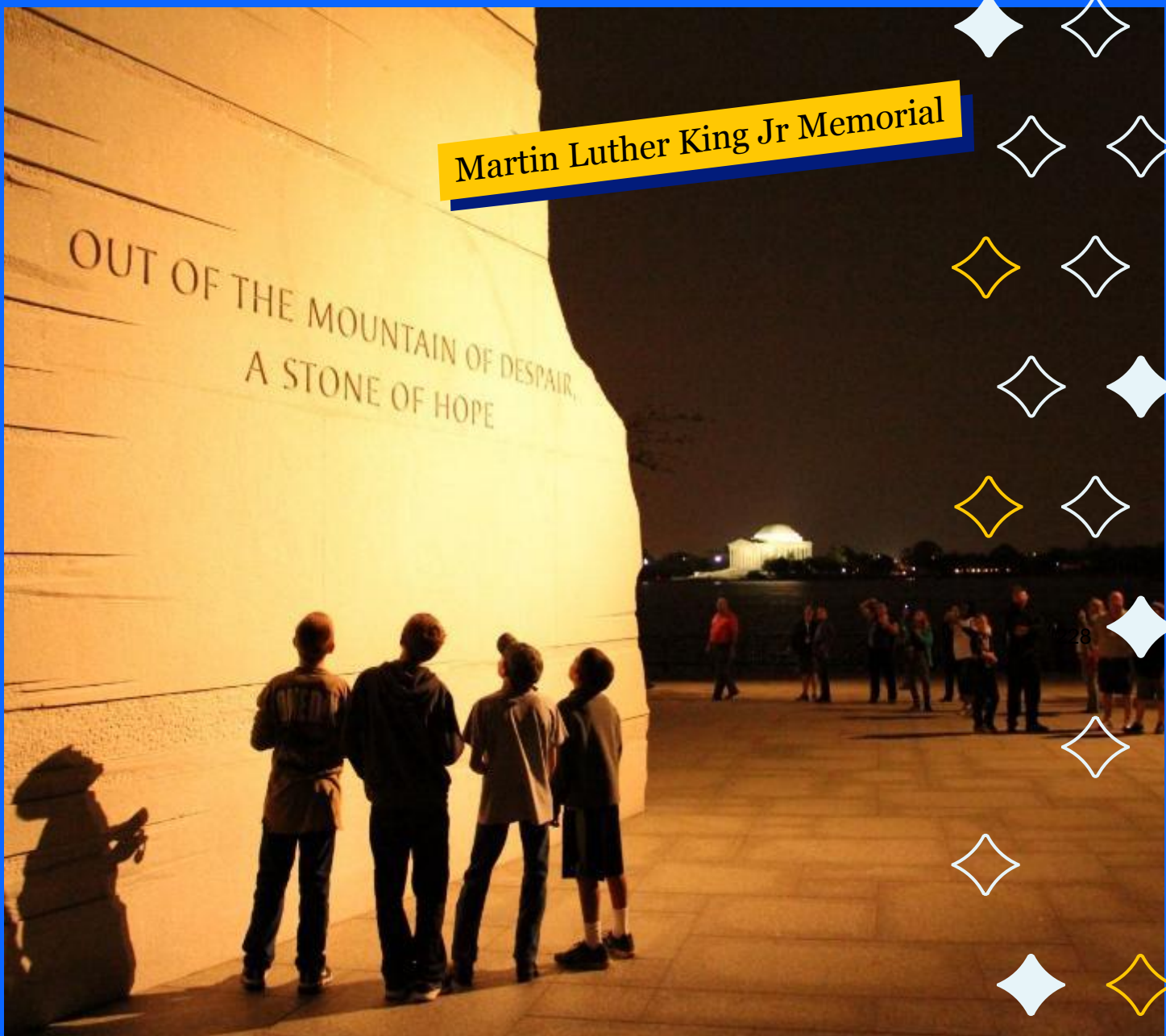

Martin Luther King Jr Memorial

Smithsonian Museums

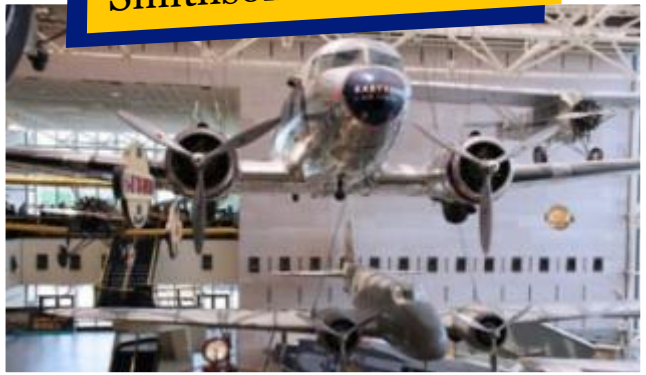

World War II Memorial

White House



Korean War Memorial



Vietnam Veterans Memorial



Washington Monument



230

A trip to remember!

WASHINGTON D.C. OUR NATION'S CAPITAL

Our trip includes

- Hotel Accommodations
- Transportation to & from our destination, and throughout the trip
- Meals
- Attractions & Activities
- Course Leader
- Academic Credit
- Discovery Journals
- Safety and Support



232



Our trip details

Advantage Payment Plan Available

Sign up by November 21, 2024, and pay only \$125 per month until the trip balance has been paid in full, even if that is after the trip takes place!

Sign up today!

worldstrides.com/register

Trip Dates: May 6th -9th, 2025

Price: Student Price: \$874. Adults in a double room:\$1,005

Deposit: \$115 required to secure your spot!

Our Registration Deadline is: November 21st, 2024

Trip ID: 220870

233

Full Refund Protection Plan: \$149

Provides a full refund of all monies paid to WorldStrides (minus the cost of the FRP program and any other non-refundable fees) should you have to cancel for any reason.

Deliver the Deepest Learning



-
- LEAP into action: Learning through Exploring and Actively Participating
 - Our trademarked learning-by-doing philosophy
 - Dynamic approach full of hands-on activities and fun



234



Earn Academic Credit Through Travel

- Online courses reflect themes and topics explored during your **travel program**. You'll choose courses from your custom menu!
- Students in grades 6-12 at time of travel are eligible to earn free **high school credit**
- Students in grades 9-12 at time of travel are eligible to earn free **college credit** in conjunction with our partner, George Mason University
- A **real differentiator** on college applications





FLAG Financial Assistance

- More than **\$2.5 million** in financial assistance given out each year
- Families with an annual adjusted gross income of **\$85,000** or less may qualify
- Learn how much may be available to you by calling **800-468-5899**





Gift of Education

- Students can send e-cards, share links on social media, or send letters to friends and family
- 100% of the money raised goes to offset the trip price

Get started at!

worldstridesfundraising.com



The screenshot shows the WorldStrides website with a navigation bar containing 'WorldStrides Local level & Expenses', 'Gift of Education', 'Fundraising Ideas', and 'Scholarships and Financial Assistance'. The main heading reads 'WorldStrides Fundraising Can Get You There' above a night photograph of the Jefferson Memorial. Below this, a paragraph states: 'WorldStrides is committed to giving every student the opportunity to experience the life-changing things that happen on our programs every day. That's why we have a whole website dedicated to funds and fundraising. Let's do this together!' Three main options are presented: 'Send an E-Card' (Our most successful fundraising tool! Raise money...), 'Share on Facebook' (Want to spread the word and also fund using...), and 'Set-Up a Fundraiser' (Rely on the experience of thousands of participants...).



Affordable Payment Plans

- Only a **small deposit** required to sign up
 - Remaining balance spread out into **smaller monthly** installments
 - Payments can be **auto-deducted** from your account
-

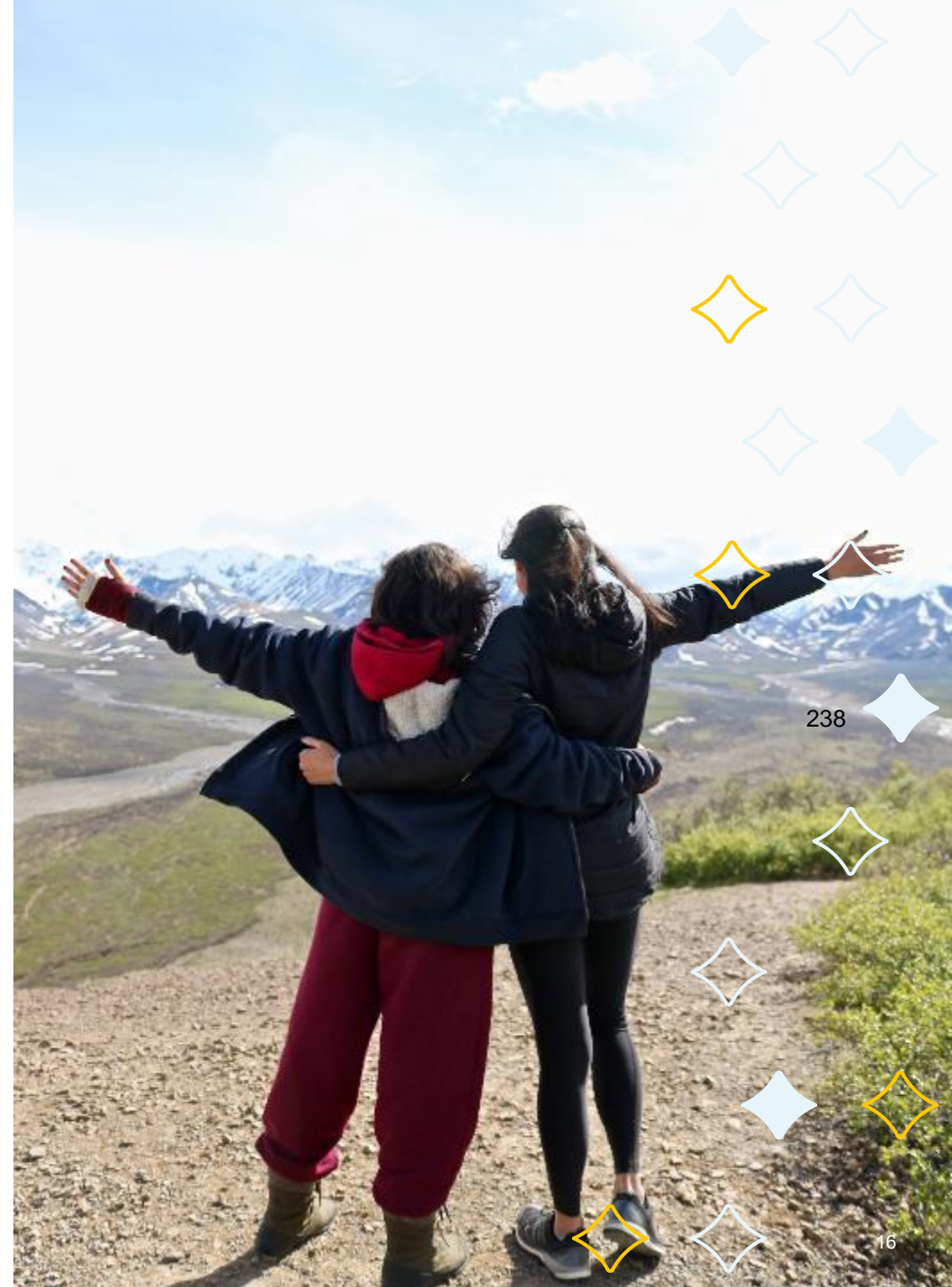

Selecting a payment plan when signing up

worldstrides.com/register

Payment Options

WorldStrides offers multiple ways to pay for your trip. Please choose the payment plan option below that best meets your needs.

We also offer an **Advantage Payment Plan** or an **Extended Payment Option** which can lower my monthly payment amount. You can contact a Customer Service Representative to help you switch to this payment plan after completing your online registration.

Pay Monthly Pay In Full

EZPay: I would like monthly payments automatically deducted from my checking account, credit card, or debit card, saving me time and money.
 Manual Pay: I would like a monthly invoice sent. A \$6.00 processing fee will be added to each invoice.

Automated Payment Deductions (EZPay)

By using your Checking Account and EZPay you can lower your monthly payments and spread out your monthly installments over time.

Checking Account Credit Card / Debit Card

Choose a deposit amount for each traveler (Minimum deposit of \$89.00 for each traveler due today)

Traveler 1 Payment Schedule

Initial Payment

\$280 Monthly | **14** Payments

Review payment schedule for Traveler 1

Your Initial Payment	\$89.00
14 standard monthly payments:	\$280.00
FINAL payment due 03-20-2025	\$108.00

Extended plans are also available by calling WorldStrides Customer Service.

Automated Monthly Payment Plans are available.

You will see the initial deposit and then your monthly payment amounts. You can call Customer Service to see how much money may be available to you through financial assistance and that amount will be deducted off your final payment.

239



WorldStrides®

Educational Travel & Experiences

Thank you for attending!

Sign up TONIGHT!
Our Trip ID is 220870



Online: worldstrides.com/register



Phone: 800-468-5899



Questions?
Email Carla.beach@myhpsd.org



We can't wait to see you all in Washington, D.C.



Ford Administration
1620 E. Elza, Hazel Park, MI 48030 | 248-658-5200 | F: 248-544-5223
www.hazelparkschools.org

To: Hazel Park Board of Education
From: Dr. Amy Kruppe
Subject: Business Consultant
Date: November 18, 2024

We are requesting approval to hire a Business Office Consultant to assist with critical tasks and provide support during the ongoing transition within our Business Office. The consultant's primary focus will be ensuring that financial processes remain accurate, compliant, and timely. Additionally, the consultant will conduct a thorough review of both past and current accounts to identify and address any discrepancies or areas for improvement.

This support is essential to maintaining the integrity of our financial operations and ensuring compliance with state and federal guidelines. The consultant will also provide expertise to address any procedural gaps and assist in training new personnel, facilitating a smooth transition for the department.

The proposed consultant has extensive experience in school business operations and will work on a short-term basis. The scope of services will be reviewed periodically to ensure alignment with district needs. The cost of this engagement, at \$125 per hour, will be covered through the district's allocated funds for professional services. The consultant will be on-site a minimum of two days per week, and we will provide monthly updates on progress at the Committee of the Whole meeting.

Strategic Goal Alignment - The request for allocating the dollars focuses on the following

- **Resources:** The Hazel Park School District will maximize its resources to assure high quality education by fostering financial stability, preserving and utilizing quality facilities, and integrating state-of-the-art technology.

Funding Source: General Funds

Recommendation: We are requesting approval to hire a Business Consultant at the rate of \$125 an hour for our Business Office operations, as presented.



Ford Administration
1620 E. Elza, Hazel Park, MI 48030 | 248-658-5200 | F: 248-544-5223
www.hazelparkschools.org

To: Dr. Amy Kruppe, Superintendent
From: Kristy Cales, Human Resource Director
Subject: Additional Part Time Security Guards
Date: November 18, 2024

We are seeking approval to add two additional part time security guards, one for each school, Hazel Park High School and Hazel Park Junior High School. These employees will work up to 20 hours per week at a rate of \$15.90/hour. They will be utilized as needed for evening events and practices at both buildings. We would require their use for building rentals and chargeback their cost to the Level 3 & 4 rentals. Tentative hours worked are 4pm - 8pm Monday through Friday.

Funding Sources: General Fund

Strategic Goal Alignment:

Resources: The Hazel Park School District will maximize its resources to assure high quality education by fostering financial stability, preserving and utilizing quality facilities, and integrating state-of-the-art technology.

Community Relations: The Hazel Park School District through strong community relations and collaboration with all stakeholders will develop high-achieving students.

Recommendation

That the Board of Education approves the hiring of two additional part time security guards for HPHS & HPJH, as presented.

**APPROVED AND RECOMMENDED FOR
BOARD ACTION**

Amy Y. Kruppe, Ed.D.
Superintendent





Ford Administration
1620 E. Elza, Hazel Park, MI 48030 | 248-658-5300 | F: 248-544-5443
www.hazelparkschools.org

Board Member Expense Reimbursement Form

Submit to the Superintendent, who will include this request in the monthly list of bills presented to the School Board. Please print and attach any receipts for all expenditures.

Name: Deborah LaFrenboise Title/Office: Trustee

Travel Destination: Lansing, Mi Purpose: Annual Conference

Departure Date: 10-24-24 Return Date: 10-26-24

[X] Receipts attached

[] Approved expense advancement (voucher) attached, if applicable*

Table with columns: Date, Mileage (Miles, Cost), Comm. Travel Expenses, Lodging, Meals (Brkfst, Lunch, Dinner), Other (Item, Cost), Daily Cost. Includes rows for dates 10-24, 10-25, 10-26 and a Total row.

Deborah LaFrenboise
Submitting Board Member's Signature

11-4-24
Date

[Signature]
Superintendent Signature

11/5/24
Date

School Board Action: [] Approved [] Denied

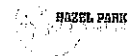



Hyatt House Lansing/University Area
 3150 E. Michigan Ave.
 Lansing, MI 48912
 Tel: 517-337-2626
 Fax: 517-337-2616
 hyatthouselansinguniversityarea.com

INVOICE

Debbie Laframboise

Confirmation No. 1231869201
 Group Name
 Booking No. 4764519981

Room No. 0260
 Arrival 10-24-24
 Departure 10-26-24
 Folio Window 1
 Folio No. 18468

Date	Description	Charges	Credits
10-24-24	Accommodation	136.00	
10-24-24	Occupancy Tax	9.52	
10-24-24	Sales Tax	8.16	
10-25-24	Accommodation	137.00	
10-25-24	Occupancy Tax	9.59	
10-25-24	Sales Tax	8.22	
10-26-24	Visa	XXXXXXXXXXXX7820 XX/XX	292.11
10-26-24	Sales Tax	-16.38	
Total		292.11	292.11

Guest Signature

Balance 0.00

I agree that my liability for this bill is not waived and I agree to be held personally liable in the event that the indicated person, company or association fails to pay for any part or the full amount of these charges.

WE HOPE YOU ENJOYED YOUR STAY WITH US!

World of Hyatt Summary

No Membership to be credited

Join World of Hyatt today and start earning points for stays, dining and more. Visit www.worldofhyatt.com

Thank you for choosing Hyatt House Lansing/University Area. Our goal is to provide every guest with an exceptional stay, and we are interested in any comments regarding your visit. Please let us know your thoughts at LANXL-Guest.Service@hyatt.com or contact us by telephone at 517-337-2626.

Please remit payment to:
 Hyatt House Lansing/University Area
 3150 E. Michigan Ave.
 Lansing, MI 48912

BROWNDOG AT THE SHUFFLE
325 Riverfront Drive
Lansing, MI 48912

BOBCAT BONNIE'S
Ferndale
637 E Michigan Ave
Lansing, MI 48912

Server: Dougie 10/26/2024
Table 41/2 5:32 PM
Guests: 1 40053
BWL D BONNIES 14.00
SOFT DRINK 4.00
Subtotal 18.00
Tax 1.08
Total 19.08
Balance Due 19.08

Thanks for joining us!
Follow us on Facebook and Instagram
@bobcatbonniesferndale

Thanks for visiting
Nuthouse Sports Grill!
420 E. Michigan Avenue
Lansing, MI 48933

Server: Mercedes 10/24/2024
Table 18/2 5:27 PM
Guests: 3 20009
Nutty Cheese Bread 10.95
Coke 3.25
HALF NACHO 8.95
Subtotal 23.15
Tax 1.39
Total 24.54
Balance Due 24.54

Had a great time? Leave us a great review!
Have a great day!

Dine In

Debby 248-275-4613

Server: FRONT C
Check #23
Ordered: 10/25/24 4:36 PM
1 MICHIGAN SALAD \$17.75
1 HOUSE FRIES \$5.00
1 FAYGO ROCK & RYE \$2.50
Subtotal \$25.25
Tax \$1.51
Tip \$5.35
Total \$32.11

Input Type C (EMV Chip Read)
VISA CREDIT xxxxxxxx7820

Transaction Type Sale
Authorization Approved
Approval Code 08979D
Payment ID brnyTTJYrWWT
Application ID A0000000031010
Application Label VISA CREDIT
Terminal ID fbb071b14b6615b0
Card Reader BBPOS

DEBORAH LAFRAMBOISE

Powered by Toast



Ford Administration
1620 E. Elza, Hazel Park, MI 48030 | 248-658-5200 | F: 248-544-5443
www.hazelparkschools.org

Board Member Expense Reimbursement Form

Submit to the Superintendent, who will include this request in the monthly list of bills presented to the School Board. Please print and attach any receipts for all expenditures.

Name: Heidi Fortress

Title/Office: Board Trustee

Travel Destination: Lansing

Purpose: MASB Conf

Departure Date: 10/24

Return Date: 10/27

Receipts attached

Approved expense advancement (voucher) attached, if applicable*

Date	Mileage		Comm. Travel Expenses	Lodging	Meals			Other		Daily Cost
	Miles	Cost			Brkfst (\$15 max)	Lunch (\$20 max)	Dinner (\$30 max)	Item	Cost	
10/24							17.97			
10/25							26.48			
10/26							15.90			
Subtotal										60.05
Advances										
Total (a negative amount indicates refund due from Board Member)										60.05

Heidi Fortress
Submitting Board Member's Signature

10/30/24
Date

[Signature]
Superintendent Signature

11/4/2024
Date

School Board Action:

Approved

Denied



BROWNDOG AT THE SHUFFLE
325 Riverfront Drive
Lansing, MI 48912

Dine In

Heidi 248-877-2277

Server: FRONT C
Check #22
Ordered: 10/25/24 4:35 PM

1 MICHIGAN SALAD \$17.75
1 FAYGO RED POP \$2.50

Subtotal \$20.25
Tax \$1.21
Tip \$4.72
Total \$26.18

Input Type C (EMV Chip Read)
Mastercard Debit xxxxxxxx8497

Transaction Type Sale
Authorization Approved
Approval Code 866593
Payment ID mbJR9RgsJwX
Application ID A000000041010
Application Label Mastercard Debit
Terminal ID fbb071b14b6615b0
Card Reader BBPOS

HEIDI M FORTRESS
Powered by Toast

Thanks for visiting
Nuthouse Sports Grill!
420 E. Michigan Avenue
Lansing, MI 48933

Server: Mercedes DOB: 10/24/2024
Table 18/1 5/50006

SALE

VC 2097164
Card #XXXXXXXXXX8497
Magnetic card present: FORTRESS HEIDI M

Card Entry Method: S

Approval: 591112

Amount: \$17.97
+ Tip: _____
= Total: _____

I agree to pay the above
total amount according to the
card issuer agreement.

Thanks for visiting Nuthouse Sports Grill!
Had a great time? Leave us a great review!
Have a great day!

Guest Copy

BOBCAT BONNIE'S
Ferndale
637 E Michigan Ave
Lansing, MI 48912

Server: Dougie
Table 41/3
Guests: 1

PLT D LOAFMEAT

Subtotal 15.00
Tax 0.90

Total 15.90

Balance Due 15.90

Thanks for joining us!
Follow us on Facebook and Instagram
@bobcatbonniesferndale



Ford Administration
1620 E. Elza, Hazel Park, MI 48030 | 248-658-5200 | F: 248-544-5223
www.hazelparkschools.org

To: Hazel Park Board of Education
From: Dr. Amy Kruppe, Superintendent
Date: November 18, 2024
Re: January Board Meeting Times

At the Committee of the Whole, it was recommended to keep the January 2025 meeting times consistent, with an exception for the Committee of the Whole meeting due to our new board member's availability. The suggested January schedule is as follows:

- January 6, 2025 – Board Workshop at 5:00 p.m.
- January 13, 2025 – Committee of the Whole at 5:00 p.m.
- January 27, 2025 – Organizational Meeting at 5:30 p.m.

This adjustment accommodates the board member's need to attend meetings starting after 4:15 p.m.

Strategic Goal Alignment

Climate and Culture: The Hazel Park School District will provide a unified system of support for all students, embracing diversity, and fostering a positive school climate.

Recommendation

That the Board of Education approve the January meeting times, as presented.

**APPROVED AND RECOMMENDED FOR
BOARD ACTION**

Amy Y. Kruppe, Ed.D.
Superintendent



Sponsors Name	Organization	Type of Fundraiser	Purpose	Beginning Date	Principal/Athlet	Superintenden	Board Shared
Hoover	Hoover	2024 Otis Spunkmeyer Cookie Dough & Fourmet Treats	Raising funds for school events, including but not limited to ROAR celebrations, Read At Home Prizes, Holiday Events and other school activities.	October 23, 2024	Yes	Yes	11/18/24



Ford Administration
1620 E. Elza, Hazel Park, MI 48030 | 248-658-5200 | F: 248-544-5223
www.hazelparkschools.org

To: Hazel Park Board of Education
From: Dr. Amy Kruppe, Superintendent
Date: November 18, 2024
Re: ADK November Winners

On behalf of ADK-Mu, we would like to congratulate our November Classroom Teacher Grant winners! Kari Obriecht (Webster) will be purchasing fidget toys and play food. Danielle Seikaly (HPS) will be buying sketchbooks for her art students.

ADK has already awarded eight grants this school year! We will continue to accept applications for classroom grants.