



Ford Administration
1620 E. Elza, Hazel Park, MI 48030 | T: 248-658-5200 | F: 248-544-5223
www.hazelparkschools.org

Agenda
Committee of the Whole Meeting

Ford Administration Building
1620 E Elza Avenue
Hazel Park, MI 48030
November 11, 2024
3:00 PM

LOCATION AND FORMAT: The meeting will be held at the Ford Administration Building, 1620 E Elza Hazel Park, Michigan. It will be live-streamed on YouTube. Members of the public wishing to speak during the public comment portion of the meeting may do so in-person or by emailing Board President, Rick Nagy, prior to the meeting at rick.nagy@myhpsd.org.

CALL TO ORDER

ROLL CALL

APPROVAL OF THE AGENDA (ACTION ITEM)

PUBLIC COMMENT

The Board of Education recognizes the value of public comment on education items and the importance of allowing members of the public to express themselves on District matters. During this portion of public comment, each statement made by a participant shall be limited to three (3) minutes and participants must identify themselves by name and address.

NEW BUSINESS

A. BUILDINGS & GROUNDS

- 1) Longfellow RFP 3
- 2) Jardon Swing 43
- 3) Basketball Backstop 44

B. PERSONNEL

- 1) Additional Part-Time Evening Security Personnel 49
- 2) Facility Usage Agreement 50
- 3) Basketball Coach 59

C. POLICY

- 1) Financial Oversight

D. FINANCE

- 1) Audit/Personnel Update

2) Check Register & CC Statement	60
E. OTHER	
1) LEO	76
2) Grants	77
a. Oakland Schools - EPIC Program	79
b. 2023 Stronger Connections Funding Cohort 2	81
c. DFC - Year 2	117
d. 35j Professional Development, Curriculum and Supports Grant	125
e. 23H - Improvement for Math	147
3) Future Board Meetings	
4) January Board Meeting Times	
5) Board Member Training	
a. First-Time Trustee Orientation Dinner - December 18th, 2024 @ 6:00pm (Oakland Schools)	

F. CLOSED SESSION

- 1) Motion to recess into closed session (e) to consult with its attorney regarding connection of specific pending litigation, but only if an open meeting would have a detrimental financial effect on litigating or settlement position of the public body pursuant to Section 8(e) of the Open Meetings Act.

REQUESTS FOR FUTURE AGENDA ITEMS

PUBLIC COMMENT

During this portion of public comment, each statement made by a participant shall be limited to one (1) minute and participants must identify themselves by name and address.

ADJOURNMENT

Any person with a disability who needs accommodation for participation in this meeting should contact the Superintendent's office at (248) 658-5220 at least five (5) days in advance of the meeting to request assistance.

All Official minutes of school board meetings are stored and available for inspection in the Ford Administration office at the above address.

This notice is given in compliance with Act No. 267 of the Public Acts Michigan, 1976



Ford Administration
1620 E. Elza, Hazel Park, MI 48030 | 248-658-5200 | F: 248-544-5223
www.hazelparkschools.org

To: Board of Education
From: Dr. Amy Kruppe, Superintendent
Subject: Longfellow RFP
Date: November 11, 2024

This memo presents the responses received to the Request for Proposal (RFP) issued for the renovations and updates required to transition the Longfellow building into the Hazel Park Community Center. The work proposed in each response will ensure the facility is appropriately equipped to support a range of community programs and activities.

The RFP's included with this memo has detailed proposals outlining work scopes, projected timelines, and cost estimates. The first proposal offers a comprehensive renovation package with an anticipated completion date of May 2025, while the second response anticipates completion by June 2025. Please review the attached summaries.

Funding Sources: Community Center Grant

Strategic Goal Alignment:

Resources: The Hazel Park School District will maximize its resources to assure high quality education by fostering financial stability, preserving and utilizing quality facilities, and integrating state-of-the-art technology.

Community Relations: The Hazel Park School District through strong community relations and collaboration with all stakeholders will develop high-achieving students.

Recommendation

That the Board of Education approve the RFP for the Longfellow Community Center, as presented..

**APPROVED AND RECOMMENDED FOR
BOARD ACTION**

Amy Y. Kruppe, Ed.D.
Superintendent



Post Bid Review Form

Project: Hazel Park Community Center Remodeling
A/E #: 4500.070
Date / Time: 10/30/2024 10:00 AM
Bid Package: Full Scope
Attendees: Tony Dattilio, Keith Norush, Sara King, Ryan Alm, Rebecca Tritt

- 1. Base Bid: **\$544,700.00** Include Addenda #s: **1**
- 5. Alternates? Yes No
- 6. Voluntary Alternates? Yes No
- 7. Mark up for additional work
 - SELF-PERFORMED **9%**
 - MATERIAL **9%**
 - SUB-CONTRACTOR **9%**
 - LABOR **9%**
- 9. Union Labor? Yes No
- 11. Sales Tax Included? Yes No
- 12. Warranty Included? Yes No
- 13. Permits Included? Yes No
- 14. Cleanup Included? Yes No
- 15. Reviewed expectations for safe / clean behaviors? Yes No
 - Temporary protection required? Yes No
 - Temporary protection included? Yes No
- 16. Temporary heat required? Yes No
 - Temporary heat included? Yes No
- 18. Has contractor visited site? Yes No
- 19. Does Bid contain qualifications or exclusions to scope of work? Yes No
- 20. Were any exceptions to contract terms and conditions noted in Bid? Yes No
- 21. Has the contractor reviewed the insurance coverage and limits Yes No

PORTAGE
 950 Trade Centre Way, Suite 130
 Portage, MI 49002
 T:800.632.7815

GRAND RAPIDS
 801 Broadway NW, Suite 306
 Grand Rapids, MI 49504
 T: 800.632.7815

CHELSEA
 300 N. Main Street, Suite 204
 Chelsea, MI 48118
 T:800.632.7815

ROYAL OAK
 818 W. Eleven Mile Road
 Royal Oak, MI 48067
 T: 800.632.7815

- Can they obtain the specified coverage limits? Yes No
- 22. Does the contractor understand the schedule start and completion dates? Yes No
- Have they included all costs to meet them? Yes No
- 23. Time required for shop drawings and submittals *4-6 weeks*
- 24. Does Bid account for all overtime and shift time necessary to complete work and meet schedule? Yes No
- 25. Contractor’s proposed field organization:
 - PM – TBD*
 - Super – TBD*
 - Estimator - Keith Norush*
- 26. Contractor’s site requirements (i.e. site trailer, parking, etc.):
 - No site needs, just parking for contractors*
- 27. Proposed Major Contractor:
 - TMX Contracting*
 - Royal West Roofing*
- 28. Does the Contractor have an understanding of the Owner facilities, utilities, power, storage, etc.?.? Yes No
- 29. Does the Contractor have a safety plan? Yes No
- Name of Safety Representative: *Sara King & Anna Halstead*
- 30. Does Contractor have documented procedures for process control (including drawings, submittals, inspection/surveillance, and training)? Yes No
- OneDrive/Excel logging, Raken app*
- Job specific safety training, EMR .73*
- 31. Bid Price Summary

a.	BASE BID	\$544,700.00
b.	Alt A1	\$34,375.00
c.	Alt A2	\$44,900.00
d.	Alt M1	\$249,000.00
	TOTAL	<u>\$872,975.00</u>

PORTAGE
 950 Trade Centre Way, Suite 130
 Portage, MI 49002
 T:800.632.7815

GRAND RAPIDS
 801 Broadway NW, Suite 306
 Grand Rapids, MI 49504
 T: 800.632.7815

CHELSEA
 300 N. Main Street, Suite 204
 Chelsea, MI 48118
 T:800.632.7815

ROYAL OAK
 818 W. Eleven Mile Road
 Royal Oak, MI 48067
 T: 800.632.7815

32. Remarks or comments:

Access Controls included in bid

This conference is in no way intended to indicate the award of a contract.

For: Summit

Signed:

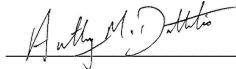

Print Name:

Tony Dattilio

Date:

10/31/2024

Kingscott Associates, Inc.



Ryan Alm

10/30/2024

PORTAGE

950 Trade Centre Way, Suite 130
Portage, MI 49002
T:800.632.7815

GRAND RAPIDS

801 Broadway NW, Suite 306
Grand Rapids, MI 49504
T: 800.632.7815

CHELSEA

300 N. Main Street, Suite 204
Chelsea, MI 48118
T:800.632.7815

ROYAL OAK

818 W. Eleven Mile Road
Royal Oak, MI 48067
T: 800.632.7815

PROPOSAL

To: Hazel Park Schools
 1620 E. Elza
 Hazel Park, MI 48030

Project: Longfellow Community Center Remodel

Location: 570 E. Mapledale Ave., Hazel Park, MI 48030

Attn: Ryan Alm
 586-764-0112

Arch/Eng'r: Kingscott Associates, Inc.
 Arch/Eng'r Project No.: 4500.07

We propose to provide the following described scope for the sum of..... **\$544,700.00**

Labor, materials, equipment and supervision to complete the Longfellow Community Center Remodel project per drawings dated 9/25/24, specifications dated 9/25/24 and addendum 1 dated 10/14/24.

- Alternate M1 **\$34,375.00**
- Alternate 1 **\$44,900.00**
- Alternate 2 **\$249,000.00**

Total for all alternates and base bid combined. **\$872,975.00**

Please Note:

- A)
- B)

Proposal price includes **ALLOWANCE(S)** for:

Permits (e.g. bldg., sewer, water, R.O.W., soil erosion) and related fees (e.g. inspection, tap, assessment, review, surety) of. **\$7,500.00**
Public utility charges (including meters) of..... **\$0.00**

Terms and Conditions

1. This proposal is based on:
 - (a) Price(s) and fee(s) firm for 20 days (see item 1f for exceptions).
 - (b) AIA Document A201 2007 edition General Conditions (unless stated otherwise in bid documents).
 - (c) Construction performed during regular work hours (except minor tie-in work or specifically stated in proposal).
 - (d) Payment terms net 30 days after our invoice is submitted.
 - (e) Owner promptly providing to us a recorded Notice of Commencement and copies of all Notices of Furnishings and/or requests for Notices of Commencement.
 - (f) CPI not increasing more than 1% and/or material/energy prices not increasing from date of this proposal.
2. This proposal excludes:
 - (a) Building and site conditions such as dewatering, unstable ground, interferences (e.g. utilities, rock, concrete, conduits), locating utility lines or other problematic conditions.
 - (b) Recognition, testing and/or removal of contaminated or hazardous gases/materials, including asbestos and lead (proposal assumes the owner will provide written notification to us if there are any contaminated or hazardous gases/materials, including asbestos and lead, on the premises with specific location(s) before construction begins).
 - (c) Winter conditions and associated costs.
 - (d) Liability in excess of our insurance coverage (proposal assumes property insurance by owner).
 - (e) General conditions and supervision costs for scope changes and owner/architect caused delays.
 - (f) Liability for any loss, damage or delay caused by acts beyond our control including acts of God, weather, failure of supplier/mfr. to perform and labor disputes.
 - (g) 3rd party inspections/testing and SWPPP for stormwater.

This proposal shall be the contract agreement or this proposal shall be part of a separate owner/contractor agreement.

Purchaser: _____

The Summit Company, Inc.

Sign/Date: _____



Keith Norush

Kingscott Associates, Inc.
Architects/Engineers
Portage, Michigan

Hazel Park Schools
Longfellow Community Center Remodeling
Hazel Park, Michigan

BID FORM

Owner:
Hazel Park Schools
Hazel Park, Michigan

The undersigned, having carefully examined the Notice to Bidders, Instruction to Bidders, the premise and conditions affecting this work, together with drawings and specifications for the **Hazel Park Schools, Longfellow Community Center Remodeling, Hazel Park, Michigan** and other documents related thereto, does hereby propose to furnish labor, materials, services and equipment necessary to complete all work, called for by and in accordance with the drawings and specifications for same, dated **September 25, 2024** including addenda numbered

#1 Dated 10/14/24.

TIME OF COMPLETION

The undersigned agrees to start work upon receipt of the Contract and shall achieve Final Completion by **July 1, 2025**. Construction is to happen beginning **January 1, 2025** with substantial completion on or before **June 1, 2025**. (Note: Contract will be issued after the November 4, 2024 School Board Meeting)

BID SECURITY

Enclosed herewith find (Certified Check), (Cashier's Check), (Bid Bond), in the amount of \$ _____ being 5% percent of the maximum bid herein, made payable to **Hazel Park Schools**. The proceeds of which are to remain the property of the **Hazel Park Schools**, if bidder does not, within ten (10) days after notice of acceptance of bid, enter into a written contract.

EXCEPTIONS AND/OR SUBSTITUTIONS

We have submitted our proposal(s) complete as specified and in accordance with the Construction Documents WITH/WITHOUT (circle one) exceptions or substitutions. (Explain the exceptions or substitutions below).

BIDDER STATUS:

(Check One)

 Individual Partnership Corporation

Submitted By:
Company

The Summit Company, Inc.

Address

13191 Wayne Rd., Livonia, MI 48150

Telephone/Fax

734-261-3500

Email

Tdattilio@summitcompany.net

Signature/Date

Tony M. Dattilio 10/22/24

Print Name/Title

Tony Dattilio, President

SCHEDULE

The proposed schedule may be a deciding factor in the selection of the successful bidder. Please indicate the proposed schedule as follows:

Proposed Material Delivery Date: Jan 31, 2025

Proposed Installation Start Date: Feb 1, 2025

Proposed Completion Date: May, 2025

END OF SECTION

Kingscott Associates, Inc.
Architects/Engineers
Portage, Michigan

Hazel Park Schools
Longfellow Community Center Remodeling
Hazel Park, Michigan

AFFIDAVIT OF BIDDER #1

The undersigned, the owner or authorized officer of The Summit Company, Inc (the "Bidder"), pursuant to the familial disclosure requirement provided in advertisement for construction bids and Instructions to Bidders, hereby represent and warrant, except as provided below, that no familial relationships exist between the owner(s) or any employee of and any other member of the Board of Education or Administration of **Hazel Park Schools**, or the Superintendent of **Hazel Park Schools**.

List any Familial Relationships:

BIDDER: The Summit Company, INC
By: Anthony Dattilio Tony Dattilio
Its: President

STATE OF MICHIGAN)
COUNTY OF Wayne)ss

This instrument was acknowledged before me on the 22nd day of October, in the year 2024, by Sara King.

Sara King
Notary Public
Wayne County, Michigan



My Commission Expires: 11/17/29
Acting in the County of: Wayne

Kingscott Associates, Inc.
Architects/Engineers
Portage, Michigan

Hazel Park Schools
Longfellow Community Center Remodeling
Hazel Park, Michigan

AFFIDAVIT OF BIDDER #2

The undersigned, the owner or authorized officer of The Summit Company, Inc.
(the "Bidder"), hereby certify that they are not an Iran-linked business nor on the U.S.
Government Services Administration's Excluded Parties List.

BIDDER: The Summit Company, INC.
By: Anthony Dattilio Tony Dattilio
Its: President

STATE OF MICHIGAN)
)ss
COUNTY OF Wayne)

This instrument was acknowledged before me on the 22nd day of October, in the year
2024, by Sara King

Sara King
Wayne, Notary Public
County, Michigan

Sara King
Notary Public State of Michigan
Wayne County
My Commission Expires 11/17/2029
Acting in the County of Wayne

My Commission Expires: 11/17/29

Acting in the County of: Wayne

AIA[®] Document A310[™] – 2010

Bid Bond

CONTRACTOR:

(Name, legal status and address)

The Summit Company Inc
13191 Wayne Road
Livonia, MI 48150

SURETY:

(Name, legal status and principal place of business)

Hudson Insurance Company
100 William Street, 5th Floor
New York, NY 10038

OWNER:

(Name, legal status and address)

Hazel Park Schools
1620 E. Elza Avenue
Hazel Park, MI 48030

BOND AMOUNT: Five Percent (5%) of Amount Bid

This document has important legal consequences. Consultation with an attorney is encouraged with respect to its completion or modification.

Any singular reference to Contractor, Surety, Owner or other party shall be considered plural where applicable.

PROJECT:

(Name, location or address, and Project number, if any)

Longfellow Community Center Remodeling

The Contractor and Surety are bound to the Owner in the amount set forth above, for the payment of which the Contractor and Surety bind themselves, their heirs, executors, administrators, successors and assigns, jointly and severally, as provided herein. The conditions of this Bond are such that if the Owner accepts the bid of the Contractor within the time specified in the bid documents, or within such time period as may be agreed to by the Owner and Contractor, and the Contractor either (1) enters into a contract with the Owner in accordance with the terms of such bid, and gives such bond or bonds as may be specified in the bidding or Contract Documents, with a surety admitted in the jurisdiction of the Project and otherwise acceptable to the Owner, for the faithful performance of such Contract and for the prompt payment of labor and material furnished in the prosecution thereof; or (2) pays to the Owner the difference, not to exceed the amount of this Bond, between the amount specified in said bid and such larger amount for which the Owner may in good faith contract with another party to perform the work covered by said bid, then this obligation shall be null and void, otherwise to remain in full force and effect. The Surety hereby waives any notice of an agreement between the Owner and Contractor to extend the time in which the Owner may accept the bid. Waiver of notice by the Surety shall not apply to any extension exceeding sixty (60) days in the aggregate beyond the time for acceptance of bids specified in the bid documents, and the Owner and Contractor shall obtain the Surety's consent for an extension beyond sixty (60) days.

If this Bond is issued in connection with a subcontractor's bid to a Contractor, the term Contractor in this Bond shall be deemed to be Subcontractor and the term Owner shall be deemed to be Contractor.

When this Bond has been furnished to comply with a statutory or other legal requirement in the location of the Project, any provision in this Bond conflicting with said statutory or legal requirement shall be deemed deleted herefrom and provisions conforming to such statutory or other legal requirement shall be deemed incorporated herein. When so furnished, the intent is that this Bond shall be construed as a statutory bond and not as a common law bond.

Signed and sealed this 22nd day of October, 2024

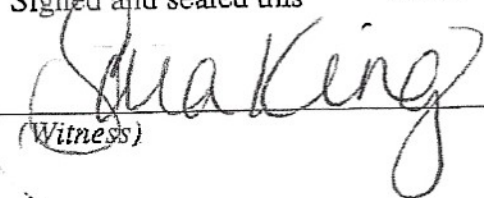

(Witness)

(Witness)

The Summit Company Inc

(Principal)

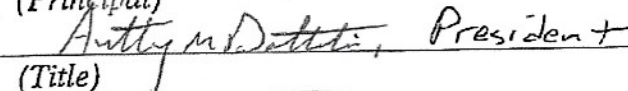
(Seal)



(Title)

Hudson Insurance Company

(Surety)

(Seal)

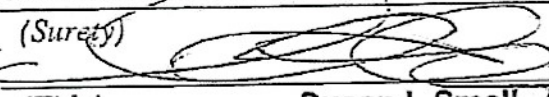
(Title)

Susan L Small, Attorney-in-Fact

Init.

AIA Document A310[™] – 2010. Copyright © 1963, 1970 and 2010 by The American Institute of Architects. All rights reserved. WARNING: This AIA[®] Document is protected by U.S. Copyright Law and International Treaties. Unauthorized reproduction or distribution of this AIA[®] Document, or any portion of it, may result in severe civil and criminal penalties, and will be prosecuted to the maximum extent possible under the law. This document was created on 01/27/2012 07:23:12 under the terms of AIA Documents-on-Demand[™] order no. 2008397483, and is not for resale. This document is licensed by The American Institute of Architects for one-time use only, and may not be reproduced prior to its completion. 061110

Proposed Contractor List

Longfellow Community Center Remodel

Hazel Park Schools

570 E. Mapledale Ave., Hazel Park, MI 48030

Scope of Work	Contractor	Contact	Phone
General Contracting	The Summit Company	Tony Dattilio	(734) 845-6506
Demolition	The Summit Company		
Carpentry	The Summit Company		
Millwork	Distinctive Interiors		
Roofing	Royal West Roofing		
Doors & Hardware	Architectural Hardware		
Flooring	Carpet Workroom		
Painting	Axtell Service Inc.		
HVAC	TMX Contracting		
Controls	K & S Ventures		
Electrical	TBD - will determine if we are awarded the contract.		

*We prefer you contact Summit regarding project information.

Post Bid Review Form

Project: Hazel Park Community Center Remodeling
A/E #: 4500.070
Date / Time: 10/29/2024 8:00 AM
Bid Package: Full Scope
Attendees: Matt Spisak, Ryan Alm, Amber Klavon, Rebecca Tritt, Reiley, McDonnell

1. Base Bid: **\$457,000.00** Include Addenda #s: **1&2**
5. Alternates? Yes No
6. Voluntary Alternates? Yes No
7. Mark up for additional work
 - SELF-PERFORMED **12%**
 - MATERIAL **12%**
 - SUB-CONTRACTOR **12%**
 - LABOR **12%**
9. Union Labor? Yes No
11. Sales Tax Included? Yes No
12. Warranty Included? Yes No
13. Permits Included? Yes No
14. Cleanup Included? Yes No
15. Reviewed expectations for safe / clean behaviors? Yes No
 - Temporary protection required? Yes No
 - Temporary protection included? Yes No
16. Temporary heat required? Yes No
 - Temporary heat included? Yes No
18. Has contractor visited site? Yes No
19. Does Bid contain qualifications or exclusions to scope of work? Yes No
 - Access Controls, allowance included for \$1500 per card reader for two totaling \$3000**
20. Were any exceptions to contract terms and conditions noted in Bid? Yes No

PORTAGE
 950 Trade Centre Way, Suite 130
 Portage, MI 49002
 T:800.632.7815

GRAND RAPIDS
 801 Broadway NW, Suite 306
 Grand Rapids, MI 49504
 T: 800.632.7815

CHELSEA
 300 N. Main Street, Suite 204
 Chelsea, MI 48118
 T:800.632.7815

ROYAL OAK
 818 W. Eleven Mile Road
 Royal Oak, MI 48067
 T: 800.632.7815

- 21. Has the contractor reviewed the insurance coverage and limits Yes No
 Can they obtain the specified coverage limits? Yes No
- 22. Does the contractor understand the schedule start and completion dates? Yes No
 Have they included all costs to meet them? Yes No
- 23. Time required for shop drawings and submittals *6-8 weeks*
- 24. Does Bid account for all overtime and shift time necessary to complete work and meet schedule? Yes No
- 25. Contractor's proposed field organization:
Will send a list of subs
Brian Beach PM
Jake Irwin Superintendent
- 26. Contractor's site requirements (i.e. site trailer, parking, etc.):
No site needs, just parking for contractors
- 27. Proposed Major Contractor:
Self-perfrom carpet and demo
Quality Air Systems is mechanical, major
- 28. Does the Contractor have an understanding of the Owner facilities, utilities, power, storage, etc.? Yes No
- 29. Does the Contractor have a safety plan? Yes No
 Name of Safety Representative: *Salvatore Amato*
- 30. Does Contractor have documented procedures for process control (including drawings, submittals, inspection/surveillance, and training)? Yes No

Pro-Core

31. Bid Price Summary

a.	BASE BID	\$457,000.00
b.	Alt A1	\$50,000.00
c.	Alt A2	\$38,000.00
d.	Alt M1	\$250,000.00
	TOTAL	<u>\$795,000.00</u>

PORTAGE
 950 Trade Centre Way, Suite 130
 Portage, MI 49002
 T:800.632.7815

GRAND RAPIDS
 801 Broadway NW, Suite 306
 Grand Rapids, MI 49504
 T: 800.632.7815

CHELSEA
 300 N. Main Street, Suite 204
 Chelsea, MI 48118
 T:800.632.7815

ROYAL OAK
 818 W. Eleven Mile Road
 Royal Oak, MI 48067
 T: 800.632.7815

32. Remarks or comments:

\$1,500 included per card reader for two totaling \$3000
\$22,850 bid bond amount

This conference is in no way intended to indicate the award of a contract.

For: Spartan

Signed: Matthew Spisak

Print Name: Matthew Spisak

Date: 10/31/24

Kingscott Associates, Inc.



Ryan Alm

10/29/2024

PORTAGE

950 Trade Centre Way, Suite 130
Portage, MI 49002
T:800.632.7815

GRAND RAPIDS

801 Broadway NW, Suite 306
Grand Rapids, MI 49504
T: 800.632.7815

CHELSEA

300 N. Main Street, Suite 204
Chelsea, MI 48118
T:800.632.7815

ROYAL OAK

818 W. Eleven Mile Road
Royal Oak, MI 48067
T: 800.632.7815

Kingscott Associates, Inc.
Architects/Engineers
Portage, Michigan

Hazel Park Schools
Longfellow Community Center Remodeling
Hazel Park, Michigan

BID FORM

Owner:
Hazel Park Schools
Hazel Park, Michigan

The undersigned, having carefully examined the Notice to Bidders, Instruction to Bidders, the premise and conditions affecting this work, together with drawings and specifications for the **Hazel Park Schools, Longfellow Community Center Remodeling, Hazel Park, Michigan** and other documents related thereto, does hereby propose to furnish labor, materials, services and equipment necessary to complete all work, called for by and in accordance with the drawings and specifications for same, dated **September 25, 2024** including addenda numbered

1 and 2.

TIME OF COMPLETION

The undersigned agrees to start work upon receipt of the Contract and shall achieve Final Completion by **July 1, 2025**. Construction is to happen beginning **January 1, 2025** with substantial completion on or before **June 1, 2025**. (Note: Contract will be issued after the November 4, 2024 School Board Meeting)

BID SECURITY

Enclosed herewith find (Certified Check), (Cashier's Check), (Bid Bond), in the amount of \$ 5% being 5% percent of the maximum bid herein, made payable to **Hazel Park Schools**. The proceeds of which are to remain the property of the **Hazel Park Schools**, if bidder does not, within ten (10) days after notice of acceptance of bid, enter into a written contract.

EXCEPTIONS AND/OR SUBSTITUTIONS

We have submitted our proposal(s) complete as specified and in accordance with the Construction Documents WITH (WITHOUT) (circle one) exceptions or substitutions. (Explain the exceptions or substitutions below).

BASE BID TOTAL for Hazel Park Schools, Longfellow Community Center, Hazel Park, Michigan

Four hundred and fifty seven thousand Dollars (\$ 457,000.00)

ALTERNATE M1 TOTAL

Additive Deductive

NET CHANGE TO BASE BID TOTAL \$ 50,000.00
Fifty thousand Dollars

ALTERNATE A1 TOTAL

Additive Deductive

NET CHANGE TO BASE BID TOTAL \$ 38,000.00
Thirty eight thousand Dollars

ALTERNATE A2 TOTAL

Additive Deductive

NET CHANGE TO BASE BID TOTAL \$ 250,000.00
Two hundred and fifty thousand Dollars

BID TOTAL (INCLUDING ALL THREE ALTERNATES) for Hazel Park Schools, Longfellow Community Center, Hazel Park, Michigan

Seven hundred and ninety five thousand Dollars (\$ 795,000.00)

ACCEPTANCE:

The undersigned agree(s) to accept a contract for the work covered by this proposal, in accordance with the contract and bidding documents.

The Owner reserves the right to accept or reject any and all proposals or parts of the same.

(CONTINUED)

THE AMERICAN INSTITUTE OF ARCHITECTS



AIA Document A310 Bid Bond

KNOW ALL MEN BY THESE PRESENTS, that **WE SPARTAN CONSTRUCTION GROUP, INC. 30956**

Industrial Rd. Livonia, MI 48150

(Here insert full name, and address or legal title of Contractor)

as Principal, hereinafter called the Principal, and **The Ohio Casualty Insurance Company Boston, MA 02116**

a corporation duly organized under the laws of the State of NH as Surety, hereinafter called the Surety, are held and firmly bound unto **Hazel Park Schools 1620 East Elza Avenue Hazel Park, MI 48030**

(Here insert full name, and address or legal title of Owner)

as Obligee, hereinafter called the Obligee, in the sum of **5.00%** Att Bid

For the payment of which sum well and truly to be made, the said Principal and the said Surety, bind ourselves, our heirs, executors, administrators, successors and assigns, jointly and severally, firmly by these presents.

WHEREAS, the Principal has submitted a bid for

Hazel Park Schools Longfellow Community Center Remodeling

(Here insert full name, address and description of project)

NOW, THEREFORE, if the Obligee shall accept the bid of the Principal and the Principal shall enter into a Contract with the Obligee in accordance with the terms of such bid and give such bond or bonds as may be specified in the bidding or Contract Documents with good and sufficient surety for the faithful performance of such Contract and for the prompt payment of labor and material furnished in the prosecution thereof, or in the event of the failure of the Principal to enter such Contract and give such bond or bonds, if the Principal shall pay to the Obligee the difference not to exceed the penalty hereof between the amount specified in said bid and such larger amount for which the Obligee may in good faith contract with another party to perform the Work covered by said bid then this obligation shall be null and void, otherwise to remain in full force and effect.

Signed and sealed this **22nd** day of **October, 2024**

Sal Amato

SPARTAN CONSTRUCTION GROUP, INC.

(Principal)

Matthew Spisak

(Seal)

(Witness)

Officer

Alexander Johnson

The Ohio Casualty Insurance Company

(Surety)

(Seal)

(Witness)

Suzan Giacoma
Suzan Giacoma, ATTORNEY-IN-FACT

AIA DOCUMENT A310 BID BOND AIA © FEBRUARY 1970 ED THE AMERICAN INSTITUTE OF ARCHITECTS, 1735 N.Y. AVE., N.W. WASHINGTON, D.C. 20006



This Power of Attorney limits the acts of those named herein, and they have no authority to bind the Company except in the manner and to the extent herein stated.

Liberty Mutual Insurance Company
The Ohio Casualty Insurance Company
West American Insurance Company

Certificate No: 8208616-013058

POWER OF ATTORNEY

KNOWN ALL PERSONS BY THESE PRESENTS: That The Ohio Casualty Insurance Company is a corporation duly organized under the laws of the State of New Hampshire, that Liberty Mutual Insurance Company is a corporation duly organized under the laws of the State of Massachusetts, and West American Insurance Company is a corporation duly organized under the laws of the State of Indiana (herein collectively called the "Companies"), pursuant to and by authority herein set forth, does hereby name, constitute and appoint, Alexandra Johnson, John W. McNish, Lois C. Brink, Michelle B. Graham, Suzan Giacona, Suzanne M. Mocerri

all of the city of Royal Oak state of MI each individually if there be more than one named, its true and lawful attorney-in-fact to make, execute, seal, acknowledge and deliver, for and on its behalf as surety and as its act and deed, any and all undertakings, bonds, recognizances and other surety obligations, in pursuance of these presents and shall be as binding upon the Companies as if they have been duly signed by the president and attested by the secretary of the Companies in their own proper persons.

IN WITNESS WHEREOF, this Power of Attorney has been subscribed by an authorized officer or official of the Companies and the corporate seals of the Companies have been affixed thereto this 19th day of August, 2022.



Liberty Mutual Insurance Company
The Ohio Casualty Insurance Company
West American Insurance Company

By: David M. Carey
David M. Carey, Assistant Secretary

State of PENNSYLVANIA ss
County of MONTGOMERY

On this 19th day of August, 2022 before me personally appeared David M. Carey, who acknowledged himself to be the Assistant Secretary of Liberty Mutual Insurance Company, The Ohio Casualty Company, and West American Insurance Company, and that he, as such, being authorized so to do, execute the foregoing instrument for the purposes therein contained by signing on behalf of the corporations by himself as a duly authorized officer.

IN WITNESS WHEREOF, I have hereunto subscribed my name and affixed my notarial seal at Plymouth Meeting, Pennsylvania, on the day and year first above written.



Commonwealth of Pennsylvania - Notary Seal
Teresa Pastella, Notary Public
Montgomery County
My commission expires March 28, 2025
Commission number 1126044
Member, Pennsylvania Association of Notaries

By: Teresa Pastella
Teresa Pastella, Notary Public

This Power of Attorney is made and executed pursuant to and by authority of the following By-laws and Authorizations of The Ohio Casualty Insurance Company, Liberty Mutual Insurance Company, and West American Insurance Company which resolutions are now in full force and effect reading as follows:

ARTICLE IV - OFFICERS: Section 12. Power of Attorney.

Any officer or other official of the Corporation authorized for that purpose in writing by the Chairman or the President, and subject to such limitation as the Chairman or the President may prescribe, shall appoint such attorneys-in-fact, as may be necessary to act in behalf of the Corporation to make, execute, seal, acknowledge and deliver as surety any and all undertakings, bonds, recognizances and other surety obligations. Such attorneys-in-fact, subject to the limitations set forth in their respective powers of attorney, shall have full power to bind the Corporation by their signature and execution of any such instruments and to attach thereto the seal of the Corporation. When so executed, such instruments shall be as binding as if signed by the President and attested to by the Secretary. Any power or authority granted to any representative or attorney-in-fact under the provisions of this article may be revoked at any time by the Board, the Chairman, the President or by the officer or officers granting such power or authority.

ARTICLE XIII - Execution of Contracts: Section 5. Surety Bonds and Undertakings.

Any officer of the Company authorized for that purpose in writing by the chairman or the president, and subject to such limitations as the chairman or the president may prescribe, shall appoint such attorneys-in-fact, as may be necessary to act in behalf of the Company to make, execute, seal, acknowledge and deliver as surety any and all undertakings, bonds, recognizances and other surety obligations. Such attorneys-in-fact subject to the limitations set forth in their respective powers of attorney, shall have full power to bind the Company by their signature and execution of any such instruments and to attach thereto the seal of the Company. When so executed such instruments shall be as binding as if signed by the president and attested by the secretary.

Certificate of Designation - The President of the Company, acting pursuant to the Bylaws of the Company, authorizes David M. Carey, Assistant Secretary to appoint such attorneys-in-fact as may be necessary to act on behalf of the Company to make, execute, seal, acknowledge and deliver as surety any and all undertakings, bonds, recognizances and other surety obligations.

Authorization - By unanimous consent of the Company's Board of Directors, the Company consents that facsimile or mechanically reproduced signature of any assistant secretary of the Company, wherever appearing upon a certified copy of any power of attorney issued by the Company in connection with surety bonds, shall be valid and binding upon the Company with the same force and effect as though manually affixed.

I, Renee C. Llewellyn, the undersigned, Assistant Secretary, The Ohio Casualty Insurance Company, Liberty Mutual Insurance Company, and West American Insurance Company do hereby certify that the original power of attorney of which the foregoing is a full, true and correct copy of the Power of Attorney executed by said Companies, is in full force and effect and has not been revoked.

IN TESTIMONY WHEREOF, I have hereunto set my hand and affixed the seals of said Companies this 22nd day of October, 2024.



By: Renee C. Llewellyn
Renee C. Llewellyn, Assistant Secretary

Not valid for mortgage, note, loan, letter of credit, currency rate, interest rate or residual value guarantees.

For bond and/or Power of Attorney (POA) verification inquiries, please call 610-832-8240 or email HOSUR@libertymutual.com.



October 29th, 2024

Hazel Park Schools Longfellow Community Center

List Of Subcontractors

Scope Of Work	Contractor
Selective Demolition	Self Perform
Carpentry	Self Perform
Roofing	Esko Roofing
Doors/ Frames/ Hardware	A&C Builders Hardware
Glazing	Glasco
Millwork	Distinctive Millwork
Flooring	Trist Creek Flooring
Painting	Trio Painting
Mechanical	Quality Aire Systems
Electrical	CC Electrical

November 7, 2024

Hazel Park Schools
1620 E. Elza
Hazel Park, MI 48030
Attention: Amy Kruppe
Re: Longfellow Community Center Remodeling Project
A/E # 04500.07

Dear Dr. Kruppe,

On Tuesday, October 22, 2024, at 2:00 PM local time, bids were taken for the Longfellow Community Center Remodeling work. Two valid bids were submitted at \$457,000 and \$544,700, not including the bid alternates. There were three bid alternates listed for various work scope; these are listed below.

There was a third bid submitted for \$78,359, but this bid has since been withdrawn due to an error by the contractor. As this bid has been withdrawn, it is excluded from this document.

The lower of the two bids was from Spartan Construction Group, Inc. at \$457,000 for the base bid amount. Based on the post-bid interview, it appears that Spartan Construction Group, Inc. has satisfied the requirements of the bid documents. Spartan Construction Group, Inc. has completed previous work for Hazel Park Schools in recent years.

In addition to the base bid, the project also included three bid alternates. The descriptions are as follows:

Alternate M-1 – Installation of two additional mechanical units to supply cooling to two additional rooms as indicated on drawings. Spartan Construction Group, Inc. submitted a bid for alternate M-1 at \$50,000.00. Kingscott recommends accepting this additive bid alternate.

Alternate A-1 – Replacement of two sets of vestibule doors and storefront at west entrance including card readers and door operators as indicated on drawings. Spartan Construction Group, Inc. submitted a bid for alternate A-1 at \$38,000.00. Kingscott recommends accepting this additive bid alternate.

Alternate A-2 – Roof replacement at three areas totaling 10,500 square feet as indicated on drawings. Spartan Construction Group, Inc. submitted a bid for alternate A-2 at \$250,000.00. Kingscott recommends accepting this additive bid alternate.



Based on our review of the bid form and on the result of the post-bid interview, Kingscott Associates, Inc. recommends that Hazel Park Schools enter into a contract with Spartan Construction Group, Inc. for the Longfellow Community Center Remodeling project as outlined in the plans and specifications prepared by Kingscott Associates, Inc. dated September 25, 2024, including Addendum 1 and 2, for the base bid project in the amount of \$457,000 (including the performance bond). Kingscott also recommends acceptance of Alternate M-1 in the amount of \$50,000.00, A-1 in the amount of \$38,000.00, A-2 in the amount of \$250,000.00. The total award amount is \$795,000.00.

Along with this letter of recommendation, we have included the bid tab results and the bid forms from both bidders. If you have any questions or concerns, please feel free to contact me.

Sincerely,

KINGSCOTT

A handwritten signature in black ink, appearing to read 'Ryan Alm'.

Ryan Alm, AIA
Project Manager

KALAMAZOO
259 E. Michigan Ave., Suite 308
Kalamazoo, MI 49007
T: 800.632.7815

GRAND RAPIDS
801 Broadway NW, Suite 306
Grand Rapids, MI 49504
T: 800.632.7815

27

CHELSEA
300 N. Main Street, Suite 204
Chelsea, MI 48118
T: 800.632.7815

ROYAL OAK
818 W. Eleven Mile Road
Royal Oak, MI 48067
T: 800.632.7815

Company	Base Bid	Alternate M-1	Alternate A-1	Alternate A-2	Total Bid	Addenda	Forms
Allied	\$78,359.00	-	\$7,600.00	-	-	1	Yes
Spartan	\$457,000.00	\$50,000.00	\$38,000.00	\$250,000.00	\$795,000.00	1 & 2	Yes
Summit	\$544,700.00	\$34,375.00	\$44,900.00	\$249,000.00	\$872,975.00	1	Yes

Kingscott Associates, Inc.
Architects/Engineers
Portage, Michigan

Hazel Park Schools
Longfellow Community Center Remodeling
Hazel Park, Michigan

BID FORM

Owner:
Hazel Park Schools
Hazel Park, Michigan

The undersigned, having carefully examined the Notice to Bidders, Instruction to Bidders, the premise and conditions affecting this work, together with drawings and specifications for the **Hazel Park Schools, Longfellow Community Center Remodeling, Hazel Park, Michigan** and other documents related thereto, does hereby propose to furnish labor, materials, services and equipment necessary to complete all work, called for by and in accordance with the drawings and specifications for same, dated **September 25, 2024** including addenda numbered

1 and 2.

TIME OF COMPLETION

The undersigned agrees to start work upon receipt of the Contract and shall achieve Final Completion by **July 1, 2025**. Construction is to happen beginning **January 1, 2025** with substantial completion on or before **June 1, 2025**. (Note: Contract will be issued after the November 4, 2024 School Board Meeting)

BID SECURITY

Enclosed herewith find (Certified Check), (Cashier's Check), (Bid Bond), in the amount of \$ 5% being 5% percent of the maximum bid herein, made payable to **Hazel Park Schools**. The proceeds of which are to remain the property of the **Hazel Park Schools**, if bidder does not, within ten (10) days after notice of acceptance of bid, enter into a written contract.

EXCEPTIONS AND/OR SUBSTITUTIONS

We have submitted our proposal(s) complete as specified and in accordance with the Construction Documents WITH (WITHOUT) (circle one) exceptions or substitutions. (Explain the exceptions or substitutions below).

BASE BID TOTAL for Hazel Park Schools, Longfellow Community Center, Hazel Park, Michigan

Four hundred and fifty seven thousand Dollars (\$ 457,000.00)

ALTERNATE M1 TOTAL

Additive Deductive

NET CHANGE TO BASE BID TOTAL \$ 50,000.00

Fifty thousand Dollars

ALTERNATE A1 TOTAL

Additive Deductive

NET CHANGE TO BASE BID TOTAL \$ 38,000.00

Thirty eight thousand Dollars

ALTERNATE A2 TOTAL

Additive Deductive

NET CHANGE TO BASE BID TOTAL \$ 250,000.00

Two hundred and fifty thousand Dollars

BID TOTAL (INCLUDING ALL THREE ALTERNATES) for Hazel Park Schools, Longfellow Community Center, Hazel Park, Michigan

Seven hundred and ninety five thousand Dollars (\$ 795,000.00)

ACCEPTANCE:

The undersigned agree(s) to accept a contract for the work covered by this proposal, in accordance with the contract and bidding documents.

The Owner reserves the right to accept or reject any and all proposals or parts of the same.

(CONTINUED)

Kingscott Associates, Inc.
Architects/Engineers
Portage, Michigan

Hazel Park Schools
Longfellow Community Center Remodeling
Hazel Park, Michigan

AFFIDAVIT OF BIDDER #2

The undersigned, the owner or authorized officer of Spartan Construction Group, Inc.
(the "Bidder"), hereby certify that they are not an Iran-linked business nor on the U.S.
Government Services Administration's Excluded Parties List.

BIDDER: Spartan Construction Group, Inc.
By: Matthew Spisak
Matthew Spisak
Its: President

STATE OF MICHIGAN)
)ss
COUNTY OF Wayne)

This instrument was acknowledged before me on the 22nd day of October, in the year
2024, by Diane L Currie
Diane L Currie

Diane L Currie

, Notary Public
Wayne County, Michigan

DIANE L CURRIE
NOTARY PUBLIC, STATE OF MICHIGAN
COUNTY OF WAYNE
My Commission Expires 12-21-2030
Acting in the County of Wayne

My Commission Expires: 12/21/2030
Acting in the County of: WAYNE

THE AMERICAN INSTITUTE OF ARCHITECTS



AIA Document A310 Bid Bond

KNOW ALL MEN BY THESE PRESENTS, that **WE SPARTAN CONSTRUCTION GROUP, INC. 30956**

Industrial Rd. Livonia, MI 48150

(Here insert full name, and address or legal title of Contractor)

as Principal, hereinafter called the Principal, and **The Ohio Casualty Insurance Company Boston, MA 02116**

a corporation duly organized under the laws of the State of NH as Surety, hereinafter called the Surety, are held and firmly bound unto **Hazel Park Schools 1620 East Elza Avenue Hazel Park, MI 48030**

(Here insert full name, and address or legal title of Owner)

as Obligee, hereinafter called the Obligee, in the sum of **5.00%** Att Bid

For the payment of which sum well and truly to be made, the said Principal and the said Surety, bind ourselves, our heirs, executors, administrators, successors and assigns, jointly and severally, firmly by these presents.

WHEREAS, the Principal has submitted a bid for

Hazel Park Schools Longfellow Community Center Remodeling

(Here insert full name, address and description of project)

NOW, THEREFORE, if the Obligee shall accept the bid of the Principal and the Principal shall enter into a Contract with the Obligee in accordance with the terms of such bid and give such bond or bonds as may be specified in the bidding or Contract Documents with good and sufficient surety for the faithful performance of such Contract and for the prompt payment of labor and material furnished in the prosecution thereof, or in the event of the failure of the Principal to enter such Contract and give such bond or bonds, if the Principal shall pay to the Obligee the difference not to exceed the penalty hereof between the amount specified in said bid and such larger amount for which the Obligee may in good faith contract with another party to perform the Work covered by said bid then this obligation shall be null and void, otherwise to remain in full force and effect.

Signed and sealed this **22nd** day of **October, 2024**

Sal Amato

(Witness)

SPARTAN CONSTRUCTION GROUP, INC.

(Principal)

Matthew Spisak

(Seal)

Officer

The Ohio Casualty Insurance Company

(Surety)

(Seal)

Suzan Giacona
Suzan Giacona, ATTORNEY-IN-FACT

(Witness)

AIA DOCUMENT A310 BID BOND AIA © FEBRUARY 1970 ED THE AMERICAN INSTITUTE OF ARCHITECTS, 1735 N.Y. AVE., N.W. WASHINGTON, D.C. 20006



This Power of Attorney limits the acts of those named herein, and they have no authority to bind the Company except in the manner and to the extent herein stated.

Liberty Mutual Insurance Company
The Ohio Casualty Insurance Company
West American Insurance Company

Certificate No: 8208616-013058

POWER OF ATTORNEY

KNOWN ALL PERSONS BY THESE PRESENTS: That The Ohio Casualty Insurance Company is a corporation duly organized under the laws of the State of New Hampshire, that Liberty Mutual Insurance Company is a corporation duly organized under the laws of the State of Massachusetts, and West American Insurance Company is a corporation duly organized under the laws of the State of Indiana (herein collectively called the "Companies"), pursuant to and by authority herein set forth, does hereby name, constitute and appoint, Alexandra Johnson, John W. McNish, Lois C. Brink, Michelle B. Graham, Suzan Giacona, Suzanne M. Mocerri

all of the city of Royal Oak state of MI each individually if there be more than one named, its true and lawful attorney-in-fact to make, execute, seal, acknowledge and deliver, for and on its behalf as surety and as its act and deed, any and all undertakings, bonds, recognizances and other surety obligations, in pursuance of these presents and shall be as binding upon the Companies as if they have been duly signed by the president and attested by the secretary of the Companies in their own proper persons.

IN WITNESS WHEREOF, this Power of Attorney has been subscribed by an authorized officer or official of the Companies and the corporate seals of the Companies have been affixed thereto this 19th day of August, 2022.



Liberty Mutual Insurance Company
The Ohio Casualty Insurance Company
West American Insurance Company

By: David M. Carey
David M. Carey, Assistant Secretary

State of PENNSYLVANIA ss
County of MONTGOMERY

On this 19th day of August, 2022 before me personally appeared David M. Carey, who acknowledged himself to be the Assistant Secretary of Liberty Mutual Insurance Company, The Ohio Casualty Company, and West American Insurance Company, and that he, as such, being authorized so to do, execute the foregoing instrument for the purposes therein contained by signing on behalf of the corporations by himself as a duly authorized officer.

IN WITNESS WHEREOF, I have hereunto subscribed my name and affixed my notarial seal at Plymouth Meeting, Pennsylvania, on the day and year first above written.



Commonwealth of Pennsylvania - Notary Seal
Teresa Pastella, Notary Public
Montgomery County
My commission expires March 28, 2025
Commission number 1126044
Member, Pennsylvania Association of Notaries

By: Teresa Pastella
Teresa Pastella, Notary Public

This Power of Attorney is made and executed pursuant to and by authority of the following By-laws and Authorizations of The Ohio Casualty Insurance Company, Liberty Mutual Insurance Company, and West American Insurance Company which resolutions are now in full force and effect reading as follows:

ARTICLE IV - OFFICERS: Section 12. Power of Attorney.

Any officer or other official of the Corporation authorized for that purpose in writing by the Chairman or the President, and subject to such limitation as the Chairman or the President may prescribe, shall appoint such attorneys-in-fact, as may be necessary to act in behalf of the Corporation to make, execute, seal, acknowledge and deliver as surety any and all undertakings, bonds, recognizances and other surety obligations. Such attorneys-in-fact, subject to the limitations set forth in their respective powers of attorney, shall have full power to bind the Corporation by their signature and execution of any such instruments and to attach thereto the seal of the Corporation. When so executed, such instruments shall be as binding as if signed by the President and attested to by the Secretary. Any power or authority granted to any representative or attorney-in-fact under the provisions of this article may be revoked at any time by the Board, the Chairman, the President or by the officer or officers granting such power or authority.

ARTICLE XIII - Execution of Contracts: Section 5. Surety Bonds and Undertakings.

Any officer of the Company authorized for that purpose in writing by the chairman or the president, and subject to such limitations as the chairman or the president may prescribe, shall appoint such attorneys-in-fact, as may be necessary to act in behalf of the Company to make, execute, seal, acknowledge and deliver as surety any and all undertakings, bonds, recognizances and other surety obligations. Such attorneys-in-fact subject to the limitations set forth in their respective powers of attorney, shall have full power to bind the Company by their signature and execution of any such instruments and to attach thereto the seal of the Company. When so executed such instruments shall be as binding as if signed by the president and attested by the secretary.

Certificate of Designation - The President of the Company, acting pursuant to the Bylaws of the Company, authorizes David M. Carey, Assistant Secretary to appoint such attorneys-in-fact as may be necessary to act on behalf of the Company to make, execute, seal, acknowledge and deliver as surety any and all undertakings, bonds, recognizances and other surety obligations.

Authorization - By unanimous consent of the Company's Board of Directors, the Company consents that facsimile or mechanically reproduced signature of any assistant secretary of the Company, wherever appearing upon a certified copy of any power of attorney issued by the Company in connection with surety bonds, shall be valid and binding upon the Company with the same force and effect as though manually affixed.

I, Renee C. Llewellyn, the undersigned, Assistant Secretary, The Ohio Casualty Insurance Company, Liberty Mutual Insurance Company, and West American Insurance Company do hereby certify that the original power of attorney of which the foregoing is a full, true and correct copy of the Power of Attorney executed by said Companies, is in full force and effect and has not been revoked.

IN TESTIMONY WHEREOF, I have hereunto set my hand and affixed the seals of said Companies this 22nd day of October, 2024.



By: Renee C. Llewellyn
Renee C. Llewellyn, Assistant Secretary

Not valid for mortgage, note, loan, letter of credit, currency rate, interest rate or residual value guarantees.

For bond and/or Power of Attorney (POA) verification inquiries, please call 610-832-8240 or email HOSUR@libertymutual.com.



Page: 1
Date: 10/22/24
Proposal No.: 24235

PROPOSAL

To: Hazel Park Schools
1620 E. Elza
Hazel Park, MI 48030

Project: Longfellow Community Center Remodel
Location: 570 E. Mapledale Ave., Hazel Park, MI 48030

Attn: Ryan Alm
586-764-0112

Arch/Eng'r: Kingscott Associates, Inc.
Arch/Eng'r Project No.: 4500.07

We propose to provide the following described scope for the sum of..... \$544,700.00

Labor, materials, equipment and supervision to complete the Longfellow Community Center Remodel project per drawings dated 9/25/24, specifications dated 9/25/24 and addendum 1 dated 10/14/24.

- Alternate M1 \$34,375.00
• Alternate 1 \$44,900.00
• Alternate 2 \$249,000.00

Total for all alternates and base bid combined. \$872,975.00

Please Note:

- A)
B)

Proposal price includes ALLOWANCE(S) for:

Permits (e.g. bldg., sewer, water, R.O.W., soil erosion) and related fees (e.g. inspection, tap, assessment, review, surety) of.. \$7,500.00
Public utility charges (including meters) of..... \$0.00

Terms and Conditions

- 1. This proposal is based on:
(a) Price(s) and fee(s) firm for 20 days (see item 1f for exceptions).
(b) AIA Document A201 2007 edition General Conditions (unless stated otherwise in bid documents).
(c) Construction performed during regular work hours (except minor tie-in work or specifically stated in proposal).
(d) Payment terms net 30 days after our invoice is submitted.
(e) Owner promptly providing to us a recorded Notice of Commencement and copies of all Notices of Furnishings and/or requests for Notices of Commencement.
(f) CPI not increasing more than 1% and/or material/energy prices not increasing from date of this proposal.
2. This proposal excludes:
(a) Building and site conditions such as dewatering, unstable ground, interferences (e.g. utilities, rock, concrete, conduits), locating utility lines or other problematic conditions.
(b) Recognition, testing and/or removal of contaminated or hazardous gases/materials, including asbestos and lead (proposal assumes the owner will provide written notification to us if there are any contaminated or hazardous gases/materials, including asbestos and lead, on the premises with specific location(s) before construction begins).
(c) Winter conditions and associated costs.
(d) Liability in excess of our insurance coverage (proposal assumes property insurance by owner).
(e) General conditions and supervision costs for scope changes and owner/architect caused delays.
(f) Liability for any loss, damage or delay caused by acts beyond our control including acts of God, weather, failure of supplier/mfr. to perform and labor disputes.
(g) 3rd party inspections/testing and SWPPP for stormwater.

This proposal shall be the contract agreement or this proposal shall be part of a separate owner/contractor agreement.

Purchaser: _____

The Summit Company, Inc.

Sign/Date: _____

Keith Norush (handwritten signature)

Keith Norush

Kingscott Associates, Inc.
Architects/Engineers
Portage, Michigan

Hazel Park Schools
Longfellow Community Center Remodeling
Hazel Park, Michigan

BID FORM

Owner:
Hazel Park Schools
Hazel Park, Michigan

The undersigned, having carefully examined the Notice to Bidders, Instruction to Bidders, the premise and conditions affecting this work, together with drawings and specifications for the **Hazel Park Schools, Longfellow Community Center Remodeling, Hazel Park, Michigan** and other documents related thereto, does hereby propose to furnish labor, materials, services and equipment necessary to complete all work, called for by and in accordance with the drawings and specifications for same, dated **September 25, 2024** including addenda numbered

#1 Dated 10/14/24.

TIME OF COMPLETION

The undersigned agrees to start work upon receipt of the Contract and shall achieve Final Completion by **July 1, 2025**. Construction is to happen beginning **January 1, 2025** with substantial completion on or before **June 1, 2025**. (Note: Contract will be issued after the November 4, 2024 School Board Meeting)

BID SECURITY

Enclosed herewith find (Certified Check), (Cashier's Check), (Bid Bond), in the amount of \$ _____ being 5% percent of the maximum bid herein, made payable to **Hazel Park Schools**. The proceeds of which are to remain the property of the **Hazel Park Schools**, if bidder does not, within ten (10) days after notice of acceptance of bid, enter into a written contract.

EXCEPTIONS AND/OR SUBSTITUTIONS

We have submitted our proposal(s) complete as specified and in accordance with the Construction Documents WITH/WITHOUT (circle one) exceptions or substitutions. (Explain the exceptions or substitutions below).

BIDDER STATUS:

(Check One)

 Individual Partnership Corporation

Submitted By:
Company

The Summit Company, Inc.

Address

13191 Wayne Rd., Livonia, MI 48150

Telephone/Fax

734-261-3500

Email

Tdattilio@summitcompany.net

Signature/Date

Tony M. Dattilio 10/22/24

Print Name/Title

Tony Dattilio, President

SCHEDULE

The proposed schedule may be a deciding factor in the selection of the successful bidder. Please indicate the proposed schedule as follows:

Proposed Material Delivery Date: Jan 31, 2025

Proposed Installation Start Date: Feb 1, 2025

Proposed Completion Date: May, 2025

END OF SECTION

Kingscott Associates, Inc.
Architects/Engineers
Portage, Michigan

Hazel Park Schools
Longfellow Community Center Remodeling
Hazel Park, Michigan

AFFIDAVIT OF BIDDER #1

The undersigned, the owner or authorized officer of The Summit Company, Inc (the "Bidder"), pursuant to the familial disclosure requirement provided in advertisement for construction bids and Instructions to Bidders, hereby represent and warrant, except as provided below, that no familial relationships exist between the owner(s) or any employee of and any other member of the Board of Education or Administration of **Hazel Park Schools**, or the Superintendent of **Hazel Park Schools**.

List any Familial Relationships:

BIDDER: The Summit Company, INC
By: Anthony Dattilo Tony Dattilo
Its: President

STATE OF MICHIGAN)
COUNTY OF Wayne)ss

This instrument was acknowledged before me on the 22nd day of October, in the year 2024, by Sara King.

Sara King
Notary Public
Wayne County, Michigan



My Commission Expires: 11/17/29
Acting in the County of: Wayne

Kingscott Associates, Inc.
Architects/Engineers
Portage, Michigan

Hazel Park Schools
Longfellow Community Center Remodeling
Hazel Park, Michigan

AFFIDAVIT OF BIDDER #2

The undersigned, the owner or authorized officer of The Summit Company, Inc.
(the "Bidder"), hereby certify that they are not an Iran-linked business nor on the U.S.
Government Services Administration's Excluded Parties List.

BIDDER: The Summit Company, INC.
By: Anthony Dattilio Tony Dattilio
Its: President

STATE OF MICHIGAN)
COUNTY OF Wayne)ss

This instrument was acknowledged before me on the 22nd day of October, in the year
2024, by Sara King

Sara King
Wayne, Notary Public
County, Michigan

Sara King
Notary Public State of Michigan
Wayne County
My Commission Expires 11/17/2029
Acting in the County of Wayne

My Commission Expires: 11/17/29

Acting in the County of: Wayne

AIA[®] Document A310[™] – 2010

Bid Bond

CONTRACTOR:

(Name, legal status and address)

The Summit Company Inc
13191 Wayne Road
Livonia, MI 48150

SURETY:

(Name, legal status and principal place of business)

Hudson Insurance Company
100 William Street, 5th Floor
New York, NY 10038

OWNER:

(Name, legal status and address)

Hazel Park Schools
1620 E. Elza Avenue
Hazel Park, MI 48030

BOND AMOUNT: Five Percent (5%) of Amount Bid

This document has important legal consequences. Consultation with an attorney is encouraged with respect to its completion or modification.

Any singular reference to Contractor, Surety, Owner or other party shall be considered plural where applicable.

PROJECT:

(Name, location or address, and Project number, if any)

Longfellow Community Center Remodeling

The Contractor and Surety are bound to the Owner in the amount set forth above, for the payment of which the Contractor and Surety bind themselves, their heirs, executors, administrators, successors and assigns, jointly and severally, as provided herein. The conditions of this Bond are such that if the Owner accepts the bid of the Contractor within the time specified in the bid documents, or within such time period as may be agreed to by the Owner and Contractor, and the Contractor either (1) enters into a contract with the Owner in accordance with the terms of such bid, and gives such bond or bonds as may be specified in the bidding or Contract Documents, with a surety admitted in the jurisdiction of the Project and otherwise acceptable to the Owner, for the faithful performance of such Contract and for the prompt payment of labor and material furnished in the prosecution thereof; or (2) pays to the Owner the difference, not to exceed the amount of this Bond, between the amount specified in said bid and such larger amount for which the Owner may in good faith contract with another party to perform the work covered by said bid, then this obligation shall be null and void, otherwise to remain in full force and effect. The Surety hereby waives any notice of an agreement between the Owner and Contractor to extend the time in which the Owner may accept the bid. Waiver of notice by the Surety shall not apply to any extension exceeding sixty (60) days in the aggregate beyond the time for acceptance of bids specified in the bid documents, and the Owner and Contractor shall obtain the Surety's consent for an extension beyond sixty (60) days.

If this Bond is issued in connection with a subcontractor's bid to a Contractor, the term Contractor in this Bond shall be deemed to be Subcontractor and the term Owner shall be deemed to be Contractor.

When this Bond has been furnished to comply with a statutory or other legal requirement in the location of the Project, any provision in this Bond conflicting with said statutory or legal requirement shall be deemed deleted herefrom and provisions conforming to such statutory or other legal requirement shall be deemed incorporated herein. When so furnished, the intent is that this Bond shall be construed as a statutory bond and not as a common law bond.

Signed and sealed this 22nd day of October, 2024

(Witness)

(Witness)

The Summit Company Inc

(Principal)

(Seal)

(Title)

Hudson Insurance Company

(Surety)

(Seal)

(Title)

Susan L Small, Attorney-in-Fact

Init.

AIA Document A310[™] – 2010. Copyright © 1963, 1970 and 2010 by The American Institute of Architects. All rights reserved. WARNING: This AIA[®] Document is protected by U.S. Copyright Law and International Treaties. Unauthorized reproduction or distribution of this AIA[®] Document, or any portion of it, may result in severe civil and criminal penalties, and will be prosecuted to the maximum extent possible under the law. This document was created on 01/27/2012 07:23:12 under the terms of AIA Documents-on-Demand[™] order no. 2008397483, and is not for resale. This document is licensed by The American Institute of Architects for one-time use only, and may not be reproduced prior to its completion. 061110



Ford Administration
1620 E. Elza, Hazel Park, MI 48030 | 248-658-5200 | F: 248-544-5223
www.hazelparkschools.org

To: Hazel Park Board of Education
From: Dr. Amy Kruppe
Subject: Installation of Sensory Swing at Jardon
Date: November 11, 2024

This memo is provide an update to the previous swing that was purchased for Jardon.

Strategic Goal Alignment - The request for allocating the dollars focuses on the following
Climate and Culture: The Hazel Park School District will provide a unified system of support for all students, embracing diversity, and fostering a positive school climate.

Funding Source: Center fund

Recommendation: N/A





Ford Administration
1620 E. Elza, Hazel Park, MI 48030 | 248-658-5200 | F: 248-544-5223
www.hazelparkschools.org

To: Hazel Park Board of Education
From: Dr. Amy Kruppe
Subject: Approval Request for Basketball Backstops
Date: November 11, 2024

We are proposing the installation of two ceiling-suspended, retractable basketball backstops to enhance the functionality and quality of our sports facilities. This project includes professional installation of high-durability backstops equipped with advanced control features and safety enhancements designed for long-term, reliable use.

Currently, our high school supports five basketball teams—three boys' teams and two girls' teams. The previous backboards were removed during the recent bleacher installation, limiting practice space for all teams. Reinstalling these backstops will provide the essential facilities our teams need to practice and compete effectively.

Total Cost: \$17,320.00

Strategic Goal Alignment - The request for allocating the dollars focuses on the following

Community Relations: The Hazel Park School District through strong community relations and collaboration with all stakeholders will develop high-achieving students.

Climate and Culture: The Hazel Park School District will provide a unified system of support for all students, embracing diversity, and fostering a positive school climate.

Funding Source: General Fund

Recommendation: That the Board approve the purchase and installation of two Basketball Backdrops not to exceed \$17,320.00, as presented.

**APPROVED AND RECOMMENDED FOR
BOARD ACTION**

Amy Y. Kruppe, Ed.D.
Superintendent



Carter Crompton, Inc.
5090 W. Frances Rd
Clio, MI 48420

PROPOSAL

Date: 11-7-24

Prepared for: Hazel Park High School
23400 Hughes Ave.
Hazel Park, MI 48030

Attention: Mr. CJ Goff cgoff22@yahoo.com
P# 586-801-2920

Project: **(2) Ceiling suspended retractable basketball backstops.**

Description:

1. (20) H-D Compression beam clamps.
2. (4) Support bridges 24'.
3. (2) 23' Sub-frame pipes.
4. (6) Support drop hangers.
5. (4) 9' Header pipes.
6. (8) 4-Ways.
7. (2) H-D Ceiling suspended retractable mono post mainframes. 25 Yr. warranty
8. (2) Knee braces.
9. (2) 120V Gear driven electric hoist. 5 Yr. warranty
10. (2) Momentary key switches.
11. Preset limit switches.
12. (2) Auto-locks. (safety straps) 5 Yr. warranty
13. (2) 42" x 72" Glass backboards. Limited lifetime warranty
14. (2) 2000+ Breakaway rims. 4 Yr. warranty
15. (2) PMCE Bolt on backboard edge padding. 5 Yr. warranty
16. Delivered and installed.

Total cost: \$ 17,320.00

NOTE: All electrical work to be done by others.

Thank you for the opportunity to submit this proposal, we appreciate your consideration.

TERMS: 50% Deposit with the order, balance due day of completion.

VALID: 30 Days.

Carter Jr. C# 810-577-7099

WINCH-QR4 110V 60HZ single phase Motorized Basketball Backstop Winch

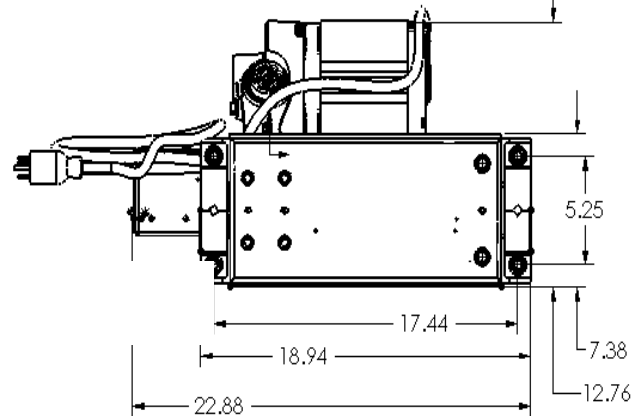
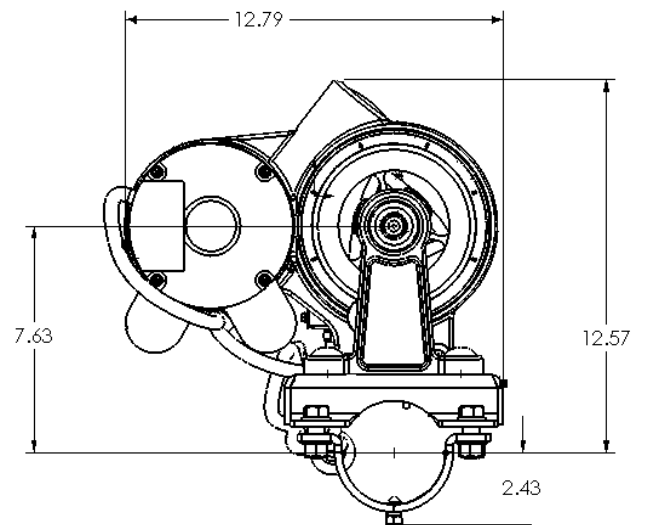
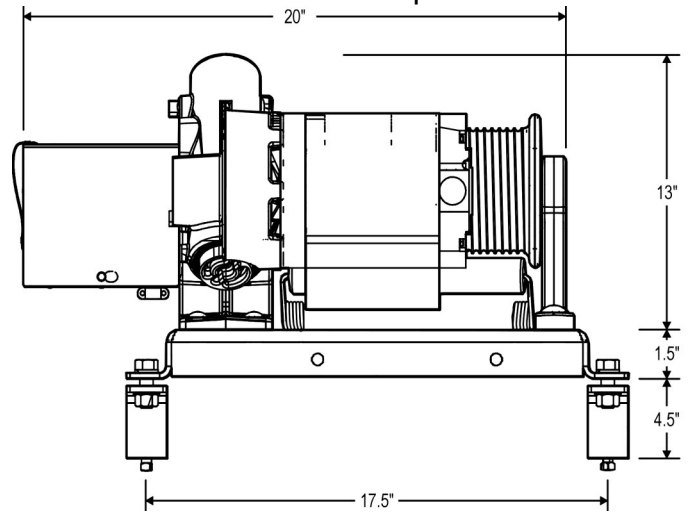
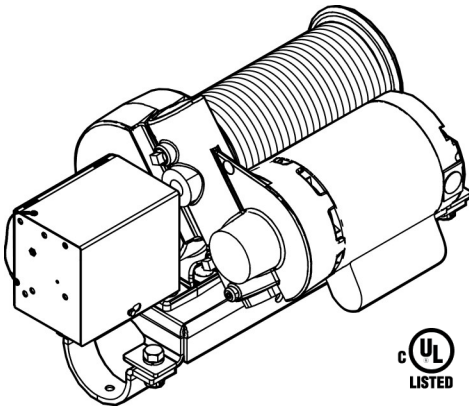

Part Number: WINCH-QR4-220V-60HZ-1PH
Lifting Capacity: 1250 Lbs / 566 Kg
Lifting Speed: 9.6 feet per minute
Motor: 3/4 Horse Power, 220v 60 HZ, single phase
POWER: 5.6 AMPS
Duty Intermittent; 10 Minutes Per Hour
Cable Drum Diameter: 4.5 Inch / 11.5 Cm
Cable Drum Capacity: 35 feet/12 Meters capacity on first layer 1/4 Inch / .64 Cm Aircraft Cable (Cable not supplied)
Gear Case: Double Reduction Lifetime Sealed Oil Bath. Precision machined positive locking direct drive with all metal gears and precision sealed ball bearings
Limit Switch: Gear driven direct drive limit switch with upper and lower settings. Positive locking for accuracy. Wire Lanyard prevents control cover from falling
Mounting: Pipe, Wall or Truss mount capable
Weight: 78 Lbs / 35 Kilograms



LynRus Gymnasium Products
 204 West 1700 South
 Salt Lake City, Utah, 84115
 www.lynrus.com
 801-486-8104

Specifications—Winch-QR4

Winch shall be rated to deliver 1250lbs/ 566kgs of vertical lifting at a line speed of 9.6 feet/2.75 meters per minute. Available cable travel shall be 32 feet/9.75 meters on one layer. Cable drum shall be manufactured from T6 heat treated aluminum alloy and shall be fully supported for maximum strength. The drum shall be helically grooved for 1/4" 7 x 19 aircraft cable. Grooving shall provide proper spooling of the cable and ensure excellent repeatability of stop positions. Drum shall be equipped with a spring tensioned pressure roller to ensure cable tracking under slack cable conditions. Winch shall be a universal mount with a 360 degree rotation allowing multiple cable routes. Winch shall employ an inherently self locking double reduction worm drive. Gearbox shall be a precision machined using only metal components for maximum gear life. The gear box shall be fully sealed and shall not require any additional lubrication for the life of the unit. Winch shall have direct drive user adjustable limit switch for up and down travel positions. Winch shall be driven by 3/4 HP, instantly reversing, 110V single-phase electric motor utilizing a 3-wire control system. Motor shall have an automatic reset overload protection, and shall draw 11.5 full load amps. Winch shall be C UL Rated

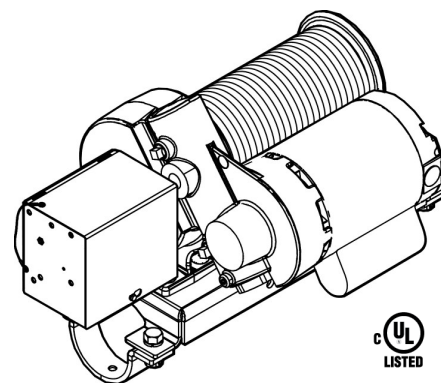

Options:

3 Position Key Switch. For secure and direct operation.

Power Wireless Remote Control. For remote control operation of electric winch.

Key switch to receptacle wiring

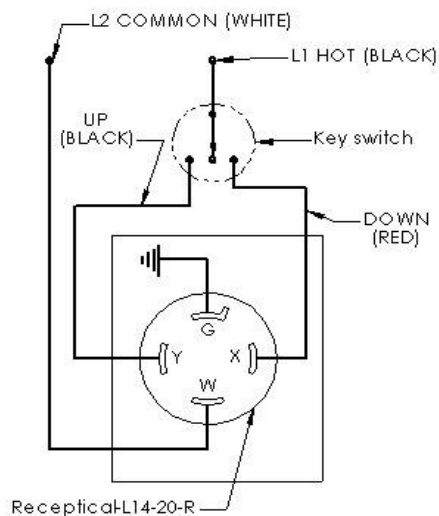

Wiring with pigtail

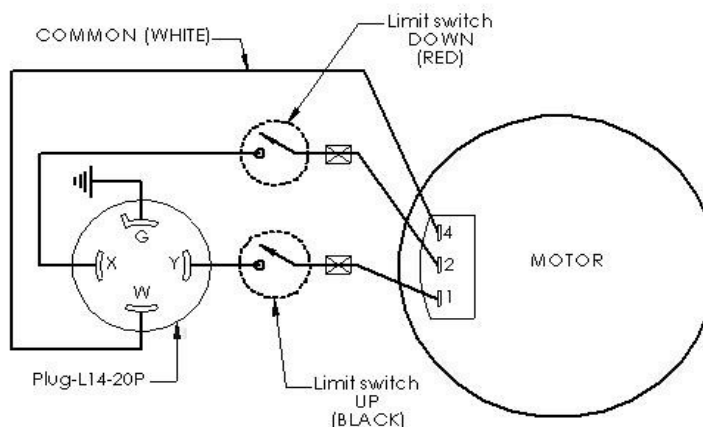

LynRus Aluminum Products - 204 West 1700 South
Salt Lake City, Utah, 84115 - www.lynrus.com - 801-486-8104

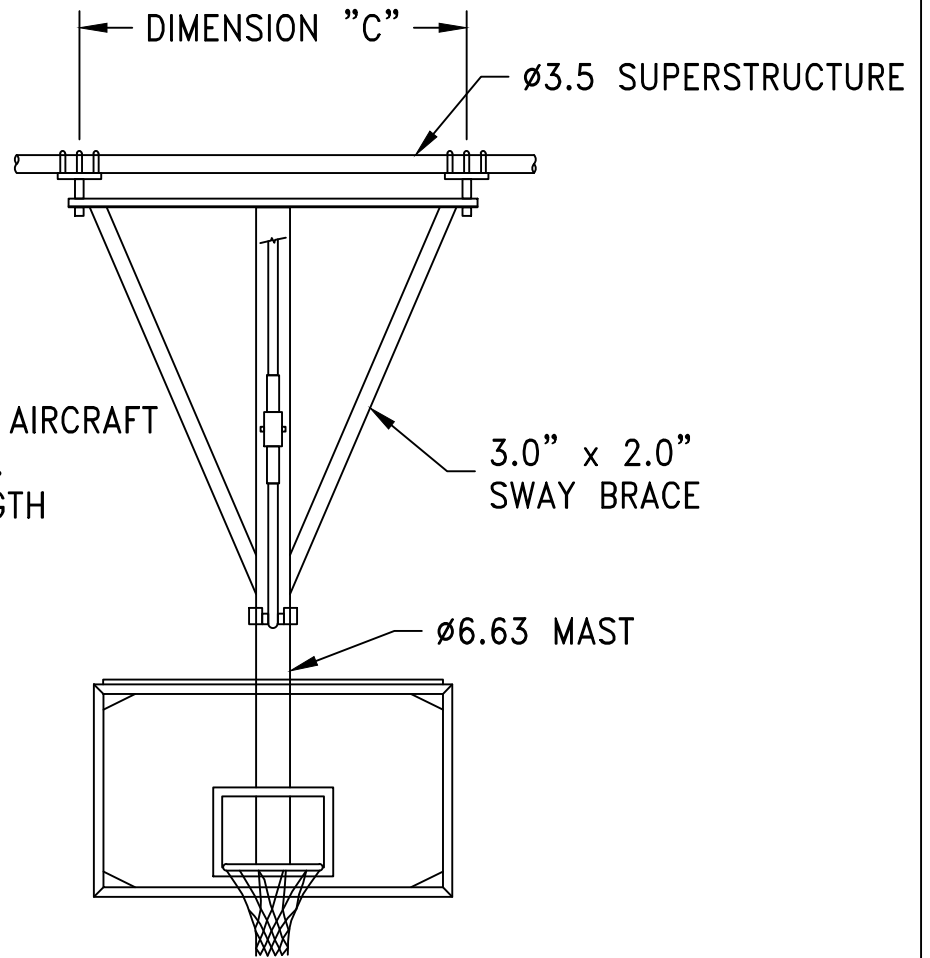
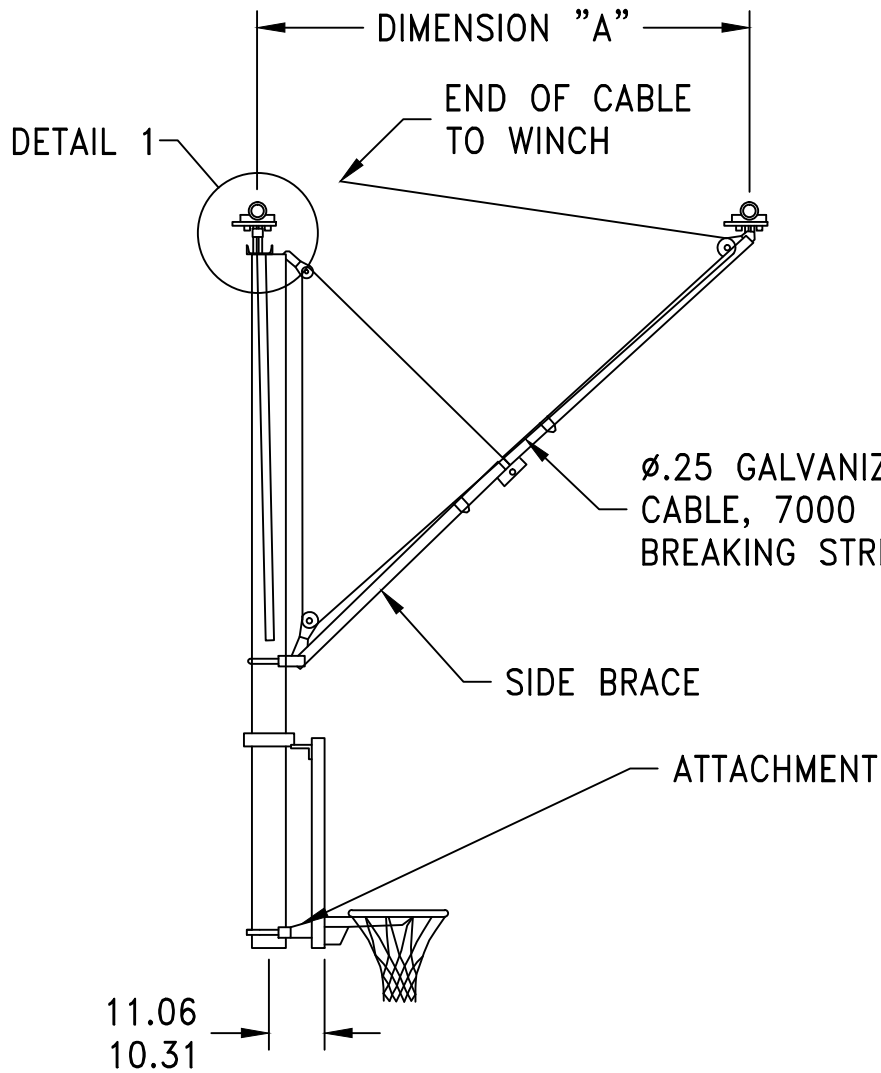



Ford Administration
1620 E. Elza, Hazel Park, MI 48030 | 248-658-5200 | F: 248-544-5223
www.hazelparkschools.org

To: Dr. Amy Kruppe, Superintendent
From: Kristy Cales, Human Resource Director
Subject: Additional Part Time Security Guards
Date: November 11, 2024

We are seeking approval to add two additional part time security guards, one for each school, Hazel Park High School and Hazel Park Junior High School. These employees will work up to 20 hours per week at a rate of \$15.90/hour. They will be utilized as needed for evening events and practices at both buildings. Tentative hours worked are 4pm - 8pm Monday through Friday.

Funding Sources: General Fund

Strategic Goal Alignment:

Resources: The Hazel Park School District will maximize its resources to assure high quality education by fostering financial stability, preserving and utilizing quality facilities, and integrating state-of-the-art technology.

Community Relations: The Hazel Park School District through strong community relations and collaboration with all stakeholders will develop high-achieving students.

Recommendation

That the Board of Education approves the hiring of two additional part time security guards for HPHS & HPJH, as presented.

**APPROVED AND RECOMMENDED FOR
BOARD ACTION**

Amy Y. Kruppe, Ed.D.
Superintendent





Ford Administration
1620 E. Elza, Hazel Park, MI 48030 | 248-658-5200 | F: 248-544-5223
www.hazelparkschools.org

To: Board of Education
From: Dr. Amy Kruppe, Superintendent
Subject: Review of Facility Usage Agreement
Date: November 11, 2024

Per the Board's request to review our current Facility Usage Agreement. It was suggested that we incorporate a structured fee to support the costs associated with maintenance, utilities, and staffing required to accommodate external events.

The Board feels the adjustment would allow us to manage facility usage more sustainably, offsetting wear and tear on our buildings and grounds, offsetting funds to pay for required staffing and ensuring availability for district needs.

Funding Sources: N/A

Strategic Goal Alignment:

Resources: The Hazel Park School District will maximize its resources to assure high quality education by fostering financial stability, preserving and utilizing quality facilities, and integrating state-of-the-art technology.

Community Relations: The Hazel Park School District through strong community relations and collaboration with all stakeholders will develop high-achieving students.

Recommendation

That the Board of Education approve the review of the Facility Usage Agreement and the proposed charge for outside organizations.

**APPROVED AND RECOMMENDED FOR
BOARD ACTION**

Amy Y. Kruppe, Ed.D.
Superintendent



**Hazel Park Schools
Building Rental Guidelines/ Costs**

The Board of Education recognizes the importance of community engagement and permits the reasonable use of its buildings and grounds by responsible community groups. This section outlines the classifications of users, the application process, regulations, fees, and other important details related to the use of District facilities.

The use of District facilities is classified into four categories:

- Class I – School Groups: Groups affiliated with the District's educational mission.
- Class II – Youth Groups: Non-District youth-oriented groups.
- Class III – Other Non-Profit Community Groups: Community-based, non-profit organizations.
- Class IV – Other Groups: Includes profit-making organizations and other groups approved by the Superintendent.

To utilize District facilities, groups must adhere to a straightforward process. Initially, they submit an application for facility use to on the school district website. Following approval, the application advances for final approval to the district. Upon successful review, approved applications result in the issuance of a permit, granting permission for the requested facility use. This systematic approach ensures transparency, accountability, and the efficient allocation of District resources for community engagement.

Fees are determined by the Superintendent and may vary based on the classification of the user group.

Waivers may be eligible for fee waivers or reduced charges at the discretion of the Superintendent.

Permit holders shoulder several critical responsibilities when using District facilities. They must supervise activities diligently to ensure the safety of participants and prevent any potential injuries or damages. Additionally, holders are required to indemnify the District against any liabilities or costs that may arise during the use of the facilities. Obtaining liability insurance coverage as mandated by the District is also a crucial requirement to mitigate risks effectively. Depending on the nature of the event, additional security measures may be necessary, and the associated costs are borne by

the user. Furthermore, understanding the cancellation terms and conditions, including advance notice requirements and specific circumstances, is essential for permit holders. Moreover, any decorations used must receive prior approval and must comply with legal standards to maintain the integrity of District property.

Certain additional guidelines must be strictly adhered to when using District facilities. Proper licensing is mandatory for any food service activities, and the public sale of materials is strictly prohibited on school premises. Furthermore, alcohol consumption and smoking are strictly forbidden to uphold a safe and healthy environment for all. The use of District equipment and supplies is limited and must be approved in advance to ensure responsible utilization. Lastly, facility usage hours are determined based on the school schedule and specific usage hours to align with the District's operational needs and priorities. These guidelines collectively contribute to the safe, organized, and efficient utilization of District facilities.

The costs for renting various District facilities depend on factors such as the classification of the user group and the specific space needed. For detailed information on hourly rates, please refer to the attached rental space chart. This chart provides a comprehensive breakdown of the costs associated with renting different types of facilities within the District, helping users make informed decisions regarding their budget and space requirements.

In addition to facility rental fees, custodial services are available at an extra cost per hour per person. The cost and need of custodial services vary based on the classification of the user group. These services ensure that the facilities are maintained in a clean and orderly manner before, during, and after use, contributing to a positive experience for all users.

For requests involving areas not listed in the rental space chart or specific services not mentioned, individuals or groups are encouraged to reach out to the appropriate District representative. These requests will be carefully considered and evaluated for feasibility and approval. Direct communication with District representatives allows for tailored solutions and ensures that all user needs are addressed effectively and efficiently.

The guidelines outlined here govern the use of District facilities, ensuring responsible and productive community engagement. This includes permitting the reasonable use of buildings and grounds by responsible community groups, with the condition that such use does not disrupt daily school activities or jeopardize the condition of District facilities. Approval for rental or use of District facilities must be obtained in advance from the Superintendent or designated authority. Additionally, the Superintendent issues administrative guidelines that further regulate the use and rental processes for District

facilities, prioritizing the District's educational mission and the well-being of its students and staff.

The Board of Education upholds a policy that allows for the reasonable utilization of its buildings and grounds, referred to as "facilities," by well-organized and responsible community groups. While these facilities are primarily intended for educational purposes and are funded by taxpayers for such use, they may also serve the broader community for activities that enhance educational, recreational, cultural, and civic endeavors for children and the community at large. The allocation of facility usage prioritizes the school program as the first priority, with other uses categorized into four classes. Within each class, facilities are made accessible on a non-discriminatory basis, ensuring fair and equitable access for all user groups.

A. Class I — School Groups

This classification includes groups whose membership and sponsor are members of the student body, District staff, community education, parent groups sponsored by the school, and/or recognized bargaining units representing District employees, or which have been approved by the Superintendent as supporting the educational needs of or promoting readiness for students potentially entering the District.

B. Class II — Youth Groups

This classification includes groups not affiliated with or sponsored by the District, but which are youth-oriented and whose membership thus largely consists of District students or youth who reside in the District. Examples include the Boy Scouts and Girl Scouts, the Little League or other youth athletic organizations.

C. Class III — Other Non-Profit Community Groups

This classification includes not-for-profit groups whose membership largely consists of members of the community who are not students of the District or who reside in the District. Examples include civic organizations, local government agencies, and other recreational activities.

D. Class IV - Other Groups

Other groups, including profit-making organizations, will be permitted to use District facilities when the anticipated use is not harmful to the public image of the District, as determined by the Superintendent or designee in his or her discretion, and will not result in misuse, overuse, or abuse of school property.

General Regulations

To maintain a smooth school day and activities, District facilities are open to Classes II, III, and IV groups at least fifteen (15) minutes after school ends or on non-school days like weekends. However, government units can use facilities during school hours for Federal, State, or local elections.

Using District facilities incurs fees set by the Superintendent. Class I or II groups may receive fee waivers or reductions as decided by the Superintendent or designee.

Before conducting any activities in District facilities, groups must submit an application for approval by District representatives. Applications follow a District-provided form which can be accessed on the website facility availability confirmation. You can submit a facility usage request using our scheduling platform FMX found both on our website and here: <https://myhpsd.gofmx.com/scheduling/requests/new> Upon availability approval, they proceed to the district for final clearance. The District retains the right to reject applications from groups with groups for the following reason, including but not limited to a history of property damage, violation of usage permits, regulations or laws. An approved application serves as a permit. However, permit holders can't deviate from permit terms unless:

1. Unforeseen circumstances require the school to use a permitted facility or maintenance work is needed to continue normal school operations. In such cases, the District may cancel the permit and return fees to the permit holder.
2. An organization with a permit can cancel its use by notifying the District in writing at least ten (10) calendar days before the scheduled time. Fees are refunded if cancellation occurs more than ten (10) days before the scheduled use; otherwise, the permit holder is responsible for the full fees.

The following terms and conditions are incorporated into each application and permit:

1. The permit holder is responsible for supervising the activities of persons using the facility for which it has obtained a permit and shall take reasonable steps to prevent injuries or damage to persons and property.
2. The District shall be fully released from and indemnified against any and all liability and costs whatsoever to persons or property for injuries or damages resulting from the use of the facilities described in the permit or any other use to which the permit holder puts the facility.
3. The permit holder will reimburse the District for the full cost of repairing any damage, over and above ordinary wear, to the facility during the permit holder's use of the facility, including damage caused by any member of the public.
4. **Liability insurance coverage, shall be obtained at the user's cost and be in the amount of \$2 million dollars.** Such insurance shall be in a form acceptable to District administrators, and a certificate of insurance coverage shall be furnished to the District before use of the facilities. The user shall provide a reasonable security deposit and/or security measures (including, without limitation, security personnel) as directed, at the user's cost.

5. The District shall be fully indemnified and released from any claim asserted by a municipality for reimbursement of additional expense for fire and/or police protection resulting from the use of a facility by an organization or individual.
6. No permit holder shall assign or sublease its permit.
7. Permit holders shall not use a District facility as their mailing address.
8. The permit holder shall indicate in all literature and other promotional materials in connection with the event to which the permit applies that the permit holder is not affiliated with the District and shall not use an image or the name of the District or facility in materials promoting the event to which the permit applies.

Permits granting use of a facility expire with the close of the school year on June 30. Annual, seasonal, and extended time use applications should be submitted at least two (2) months before the proposed starting date of the use. The District reserves the right to use, for any purpose, any portion of a facility not specifically reserved by the permit at the same time the permit is in effect.

A permit holder shall not serve food during an event unless proper licensing has been secured from the Oakland County Department of Health and approved by the district. The public sale of materials, except as incidental to the program for which a permit has been issued, is prohibited on District premises. The District reserves the right to utilize its in house provider for food services

The District representative must approve any decorations erected in connection with a permitted use. Any such decorations must also satisfy any legal requirements of the State of Michigan and local municipalities. Approved decorations must be erected so as not to damage or destroy District property. Decorations shall be removed from the facility by the permit holder before 8:00 a.m. on the day after the use.

With respect to fire prevention and safety, smoking on school property is prohibited. The use of open flames at a District facility, except as part of the school curriculum, is prohibited. Exits and corridors must be kept free of obstructions to ingress and egress.

The possession or use of alcoholic beverages on school property is prohibited.

Permit holders shall not use District supplies or materials. Permit holders' supplies and materials may be stored in a District building only with the permission of the building administrator.

Permit holders may use District equipment only if and to the extent stated in the permit.

Appropriate shoes must be worn by participants using gymnasium floors.

NO animals (unless approved by the administration) shall be allowed on the school ground or in the facilities included by not limited to the athletic stadiums.

No bikes, scooters, skateboards or strollers are allowed on the track or football field.

A use permit is subject to immediate cancellation if these regulations or any other requirements imposed by the District are not followed or if there is a violation of the law while District facilities are being used. Violations of the procedures may lead to an organization forfeiting the ability to rent or use the facilities with the school district in the future.

I agree to the terms and conditions set above.

[Individual Representing]
[Name of Outside Group]

Date

Those wishing to use Camp Hazelwood should contact ryann.voss@myhpsd.org .
 Discounts for daily or week usage may be available.

<u>Rental Space</u>	<u>Class 1: School Groups</u>	<u>Class II: Youth Groups</u>	<u>Class III Other Non-Profit Groups</u> (Per hour costs)	<u>Class IV: Other Groups:</u> (Per hour costs)	<u>Deposit due one week after permit approval</u>
<u>Classroom</u>	<u>\$0</u>	<u>\$0</u>	<u>\$10</u>	<u>\$20</u>	<u>\$100</u>
<u>Media Center</u>	<u>\$0</u>	<u>\$0</u>	<u>\$15</u>	<u>\$30</u>	<u>\$100</u>
<u>Cafeteria</u>	<u>\$0</u>	<u>\$0</u>	<u>\$15</u>	<u>\$30</u>	<u>\$100</u>
<u>Large Gym (HS)</u>	<u>\$0</u>	<u>\$0</u>	<u>\$40</u>	<u>\$80</u>	<u>\$200</u>
<u>Aux. Gym (HS</u>	<u>\$0</u>	<u>\$0</u>	<u>\$30</u>	<u>\$60</u>	<u>\$200</u>
<u>MS Gym</u>	<u>\$0</u>	<u>\$0</u>	<u>\$30</u>	<u>\$60</u>	<u>\$200</u>
<u>Elementary Gym</u>	<u>\$0</u>	<u>\$0</u>	<u>\$25</u>	<u>\$50</u>	<u>\$200</u>

<u>HS pools w/o lif guards</u>	<u>\$0</u>	<u>\$0</u>	<u>\$40</u>	<u>\$80</u>	<u>\$200</u>
<u>HS pool with life guards</u>	<u>\$0</u>	<u>\$35 per life guards</u>	<u>\$75 with one life guard +\$35 for each guard needed</u>	<u>\$110 with one life guard+\$35 for each after</u>	<u>\$200</u>
<u>Football</u>	<u>\$0</u>	<u>\$0</u>	<u>\$175 an hour</u>	<u>\$250 an hour</u>	<u>\$500</u>

<u>game field</u>					
<u>Turf practice field</u>	<u>\$0</u>	<u>\$0</u>	<u>\$125 an hour</u>	<u>\$200 an hour</u>	<u>\$500</u>
<u>Other fields</u>	<u>\$0</u>	<u>\$0</u>	<u>\$75 a game</u>	<u>\$125 a game</u>	<u>\$200</u>
<u>Board room</u>	<u>\$0</u>	<u>\$0</u>	<u>\$50 an hour</u>	<u>\$75 an hour</u>	<u>\$100</u>
<u>Camp Hazelwood</u>	<u>\$0</u>	<u>\$0</u>	<u>\$75 an hour</u>	<u>\$100 an hour</u>	<u>\$250</u>
<u>Auditorium High School</u>	<u>\$0</u>	<u>\$0</u>	<u>\$80 an hour</u>	<u>\$100 an hour</u>	<u>\$200</u>
<u>Auditorium Junior High</u>	<u>\$0</u>	<u>\$0</u>	<u>\$60 an hour</u>	<u>\$80 an hour</u>	<u>\$160</u>
<u>Custodial per person</u>	<u>\$0</u>	<u>\$0</u>	<u>\$50 an hour</u>	<u>\$75 an hour</u>	
<u>Other areas upon request</u>					



Ford Administration
1620 E. Elza, Hazel Park, MI 48030 | 248-658-5200 | F: 248-544-5223
www.hazelparkschools.org

To: Board of Education
From: Dr. Amy Kruppe, Superintendent
Subject: Recommendation to Hire Basketball Coach
Date: November 11, 2024

We have reviewed the application of an individual interested in a coaching position with our basketball program. While this candidate has a felony on their record, they possess the skills, experience, and positive impact that could benefit our student-athletes. This individual also has many years of experience as a coach at the recreational level. After a thorough review process, including consideration of their rehabilitation efforts and commitment to positive community engagement, we believe this individual could be an asset to our program.

We are prepared to discuss this recommendation in greater detail, including any specific conditions or oversight measures that could be put in place to ensure a safe and supportive environment for our students. We value the Board's input as we move forward with this candidate.

Funding Sources: General Fund

Strategic Goal Alignment:

Resources: The Hazel Park School District will maximize its resources to assure high quality education by fostering financial stability, preserving and utilizing quality facilities, and integrating state-of-the-art technology.

Community Relations: The Hazel Park School District through strong community relations and collaboration with all stakeholders will develop high-achieving students.

Recommendation

That the Board of Education approve the hiring of a Basketball Coach, as presented.

**APPROVED AND RECOMMENDED FOR
BOARD ACTION**

Amy Y. Kruppe, Ed.D.
Superintendent





Hazel Park School District

ALL IN ALL THE TIME

Amy Kruppe, Ed.D.
Superintendent

Ford Administration

1620 E. Elza, Hazel Park, MI 48030 • Phone 248-658-5200 | Fax 248-544-5443

TO: The School District of the City of Hazel Park
Board of Education

FROM: Crystal Mubarak
Director of Business

RE: Treasurer's Report October, 2024

DATE: November 4, 2024

Attached is the check register (including current period voids), a listing of ACH debits, wire transfers, and P-Card purchases made during the period

GENERAL FUND (11)		1,155,808.87	
	<i>Total - General Fund</i>	<u>\$ 1,155,808.87</u>	
CENTER PROGRAM (22)		17,562.06	
COMMUNITY SERVICE (23)		639.71	
FOOD SERVICE FUND (25)		287,350.19	
COMMON DEBT (31-39)		0.00	
CAPITAL PROJECTS (41-49)		12,225.81	
	<i>Total - Special Revenue Funds</i>	<u>\$ 317,777.77</u>	
TRUST FUNDS (51)		0.00	
INTERNAL ACCOUNT FUNDS (29)		12,186.86	
	<i>Total - Other Funds</i>	<u>\$ 12,186.86</u>	
TOTAL CHECK DISBURSEMENTS		<u><u>\$ 1,485,773.50</u></u>	\$ 1,485,773.50
ACH DEBITS			2,289,351.78
PAYROLL			1,766,170.57
OUTGOING WIRE TRANSFERS			2,814,951.69
P-CARD PURCHASES			<u>101,928.37</u>
			6,972,402.41
TOTAL DISBURSEMENTS IN PERIOD			<u><u>\$ 8,458,175.91</u></u>

I certify that the disbursements listed on the attached check registers and listing of ACH debits, wire transfers, and P-Card purchases were payments made for obligations of The School District of the City of Hazel Park and that all materials or services listed on the invoices have been received or performed.

Crystal Mubarak
Director of Business

Monthly Summary of EFT's from HP Bank Accounts

Oct-24

<u>Date</u>	<u>Amount</u>	<u>Bank Acct Taken From</u>	<u>Reason</u>
10/2/2024	\$302.59	Gen Funds	Latchkey Fees
10/7/2024	\$6,096.69	Gen Funds	Health Equity Payment October 4th Payroll
10/23/2024	\$5,673.78	Gen Funds	Health Equity Payment October 18th Payroll
10/3/2024	\$12,569.75	Gen Funds	EduStaff Payment
10/17/2024	\$19,329.47	Gen Funds	EduStaff Payment
10/31/2024	\$17,476.79	Gen Funds	EduStaff Payment
10/8/2024	\$23,271.74	Gen Funds	Penserv Payment October 4th Payroll
10/24/2024	\$22,655.42	Gen Funds	Penserv Payment October 18th Payroll
10/4/2024	\$48,216.68	Tax W/H	Payroll State Tax Withholding October 4th
10/23/2024	\$41,555.19	Tax W/H	Payroll State Tax Withholding October 18th
10/4/2024	\$336,470.92	Tax W/H	Payroll Federal Tax Withholding October 4th
10/22/2024	\$281,921.09	Tax W/H	Payroll Federal Tax Withholding October 18th
10/7/2024	\$427,624.23	Ret W/H	Payroll Retirement Withholding September 20th
10/17/2024	\$531,853.01	Ret W/H	Payroll Retirement Withholding October 4th
10/30/2024	\$514,334.43	MESSA	MESSA Payments

\$2,289,351.78 Total ACH Debits

<u>Date</u>	<u>Amount</u>	<u>Payroll</u>
10/4/2024	\$908,673.53	General Payroll on October 4th
10/18/2024	\$857,497.04	General Payroll on October 18th

\$1,766,170.57 Total Payroll

<u>Date</u>	<u>Amount</u>	<u>Wires</u>
10/28/2024	\$2,814,951.69	MVCA Wire State Aid

\$2,814,951.69 Total Wires

<u>Date</u>	<u>Amount</u>	<u>P-Card Purchases</u>
10/22/2024	\$101,928.37	General P-Card charges Huntington Bank

\$101,928.37 Total P-Card Purchases

Hazel Park Schools
Budget to Actual by St Revenue and St Function
As of 10/31/2024

St Revenue/Function	Description		Original Budget	Encumbrance	Actual	Balance	Percent
Type: 4 Revenue							
St Revenue: 100	Revenue from Local Sources	Total:	6,310,500.00	0.00	3,720,688.71	1,983,825.29	58.96%
St Revenue: 300	Rev from State Sources	Total:	43,062,068.00	0.00	0.00	28,907,259.00	0.00%
St Revenue: 400	Rev from Federal Sources	Total:	1,862,829.00	0.00	0.00	7,553,087.00	0.00%
St Revenue: 500	Incoming Transfer/Oth Transact	Total:	2,940,000.00	0.00	0.00	2,430,209.40	0.00%
St Revenue: 600	Fund Modifications	Total:	1,687,000.00	0.00	0.00	1,619,040.36	0.00%
Type: 4		RevenueTotal:	55,862,397.00	0.00	3,720,688.71	42,493,421.05	6.66%
Type: 5 Expense							
St. Function:110	Basic Programs	Total:	21,884,914.00	287,502.80	6,127,382.31	15,757,531.69	28.00%
St. Function:120	Added Needs	Total:	11,112,868.00	7,410.46	2,900,712.87	5,725,180.13	26.10%
St. Function:210	Support Services-Pupil	Total:	4,178,712.00	1,491.56	1,177,158.23	1,767,954.77	28.17%
St. Function:220	Support Services-Instr Staff	Total:	3,741,471.00	43,742.97	980,596.39	1,454,819.61	26.21%
St. Function:230	Support Services-General Admin	Total:	793,531.00	1,900.37	361,736.48	371,589.52	45.59%
St. Function:240	Support Services-School Admin	Total:	2,584,742.00	5,560.64	672,046.36	1,413,188.64	26.00%
St. Function:250	Support Services-Business	Total:	810,588.00	7,916.00	316,307.31	413,412.69	39.02%
St. Function:260	Operations and Maintenance	Total:	5,965,755.00	94,783.11	1,938,115.20	3,401,969.80	32.49%
St. Function:270	Pupil Transportation Services	Total:	978,544.00	5,685.00	259,932.98	59,750.02	26.56%
St. Function:280	Support Services-Central	Total:	2,185,108.00	22,061.29	780,564.11	696,783.89	35.72%
St. Function:290	Support Services-Other	Total:	813,672.00	73,680.75	161,525.28	355,205.01	19.85%
St. Function:330	Community Activities	Total:	330,297.00	0.00	105,254.24	(86,723.63)	31.87%
St. Function:390	Other Community Services	Total:	393,000.00	537.04	143,710.38	68,512.48	36.57%
St. Function:440	Pymts to Other Govnmt	Total:	293,000.00	0.00	0.00	266,665.00	0.00%
St. Function:510	Debt Services - Long Term Only	Total:	33,000.00	0.00	0.00	33,000.00	0.00%
St. Function:600	Transfers Out	Total:	293,000.00	0.00	11,343.75	280,744.25	3.87%
Type: 5		ExpenseTotal:	56,392,202.00	552,271.99	15,936,385.89	29,817,758.87	28.26%
Grand Total:			-529,806.00		-12,215,697.18	12,675,662.18	

Hazel Park Schools
Check Register by Fund
Check Date From 10/1/2024 TO 10/31/2024

Check Date	Check#	PE ID	Vendor Name	PO#	Amount
Fund: 110					
10/04/2024	EH 00001285	100045	A & I ENTERPRISES		174,643.14
10/04/2024	EH 00001286	100550	AMAZON CAPITAL SERVICES INC	P2500103	1,177.48
10/04/2024	EH 00001287	100503	HEMPLE, CHARLES		80.00
10/04/2024	EH 00001288	100745	KSS ENTERPRISES		9,016.03
10/04/2024	EH 00001289	101330	MICHIGAN STAGE		9,000.00
10/04/2024	EH 00001290	100397	SCHOOL SPECIALTY	P2500094	4,721.44
10/04/2024	HP 00504011	101392	ACCELERATE4KIDS FOUNDATION		2,400.00
10/04/2024	HP 00504012	101162	ALRO STEEL CORPORATION		625.19
10/04/2024	HP 00504014	100354	AUTO ZONE		216.71
10/04/2024	HP 00504015	100448	CDW-G	P2500090	37,705.05
10/04/2024	HP 00504016	100322	CITY HAZEL PARK WATER		4,946.38
10/04/2024	HP 00504017	101449	DCA PRODUCTS INC		1,063.00
10/04/2024	HP 00504018	100361	DOWNRIVER REFRIGERATION SUPPLY		279.33
10/04/2024	HP 00504019	100313	DTE ENERGY		1,192.33
10/04/2024	HP 00504021	100446	FAR THERAPEUTIC & PERFORMING ARTS		168.75
10/04/2024	HP 00504022	100455	GRAINGER		36.89
10/04/2024	HP 00504023	100707	HARRIS, JEFFREY		40.00
10/04/2024	HP 00504024	101435	HERRON, CHLOE		80.00
10/04/2024	HP 00504025	101138	HODGSON , JASON		120.00
10/04/2024	HP 00504026	100830	INTERACTIVE ENERGY GROUP LLC		264.15
10/04/2024	HP 00504027	100521	INTERNATIONAL PLUMBING CO		14,830.00
10/04/2024	HP 00504028	101419	LIVING ARTS		1,250.00
10/04/2024	HP 00504029	100089	MCNAUGHTON-MCKAY ELECTRIC COMP		263.05
10/04/2024	HP 00504030	100481	OAKLAND COMMUNITY COLLEGE		1,209.75
10/04/2024	HP 00504031	101447	PHAUP, DANNY RAY		40.00
10/04/2024	HP 00504032	101448	POUGET, GAGE		104.48
10/04/2024	HP 00504033	100468	PROGRESSIVE PLUMBING SUPPLY		130.68
10/04/2024	HP 00504034	100525	ROBERT BROOKE & ASSOCIATES INC	P2500091	563.38
10/04/2024	HP 00504035	100796	SAVVAS LEARNING COMPANY LLC	P2500098	910.00
10/04/2024	HP 00504036	101434	SCOTT, RONALD		40.00

Hazel Park Schools
Check Register by Fund
Check Date From 10/1/2024 TO 10/31/2024

Check Date	Check#	PE ID	Vendor Name	PO#	Amount
10/04/2024	HP 00504037	101431	TIMS GLASS INC		120.00
10/04/2024	HP 00504039	100364	VIGILANTE SECURITY INC		179.00
10/04/2024	HP 00504040	100378	BUCKLES & BUCKLES		103.33
10/04/2024	HP 00504041	100512	CHAPTER 13 TRUSTEE - T. TERRY		1,115.00
10/04/2024	HP 00504042	100609	DAVID RUSKIN		556.58
10/04/2024	HP 00504043	100387	MISDU		551.60
10/04/2024	HP 00504044	101139	SCHEER GREEN AND BURKE CO. LPA		356.73
10/04/2024	HP 00504045	101439	VELO LAW OFFICE		100.00
10/14/2024	EH 00001291	100351	AIRGAS GREAT LAKES		59.65
10/14/2024	EH 00001292	100550	AMAZON CAPITAL SERVICES INC	P2500125	5,051.23
10/14/2024	EH 00001293	100802	CURRICULUM ASSOCIATES LLC	P2500068	21,391.60
10/14/2024	EH 00001294	100430	JG POLY SALES		95.80
10/14/2024	EH 00001295	100745	KSS ENTERPRISES		10,415.65
10/14/2024	EH 00001296	100380	OAKLAND SCHOOLS	P2500142	274.38
10/14/2024	EH 00001297	100538	PROJECT LEAD THE WAY INC	P2500111	1,657.00
10/14/2024	EH 00001298	100428	ROYAL ROOFING		477.00
10/14/2024	EH 00001299	100397	SCHOOL SPECIALTY	P2500105	1,611.86
10/14/2024	EH 00001300	100504	SET SEG		51,382.00
10/14/2024	EH 00001301	100515	STAFF CONNECTIONS LLC		7,084.75
10/14/2024	HP 00504047	100544	ASCENSION MICHIGAN EMPLOYER SOLUTIONS		50.00
10/14/2024	HP 00504048	100354	AUTO ZONE		29.40
10/14/2024	HP 00504049	100935	BIRMINGHAM PUBLIC SCHOOLS		200.00
10/14/2024	HP 00504050	100462	CENGAGE LEARNING	P2500099	26,757.50
10/14/2024	HP 00504051	100309	CONSUMERS ENERGY		3,403.33
10/14/2024	HP 00504052	100185	DETROIT NATIVE SUN NEWSPAPER GROUP		1,180.00
10/14/2024	HP 00504053	100361	DOWNRIVER REFRIGERATION SUPPLY		240.73
10/14/2024	HP 00504054	100313	DTE ENERGY		25,046.21
10/14/2024	HP 00504056	100392	FLINN SCIENTIFIC INC	P2500131	144.10
10/14/2024	HP 00504057	100576	LEARNING WITHOUT TEARS	P2500112	13,674.38
10/14/2024	HP 00504058	101282	LEWIS TIRE SERVICE		445.00
10/14/2024	HP 00504060	100413	MCGRAW HILL BOOK CO	P2500079	2,566.94

64

User: MILLERM - Matthew Miller

Page

Current Date: 11/04/2024

Report: OSAP5009 - OSAP5009: Check Register by Fund

2

Current Time: 09:29:49

Selection:

OH_DTL.[oh_ck_dt] <= '10/31/2024' AND OH_DTL.[oh_ck_dt] >= '10/01/2024'

Hazel Park Schools
Check Register by Fund
Check Date From 10/1/2024 TO 10/31/2024

Check Date	Check#	PE ID	Vendor Name	PO#	Amount
10/14/2024	HP 00504061	101052	NORTHSTAR MAT SERVICE		696.48
10/14/2024	HP 00504062	100202	ORKIN LLC		160.99
10/14/2024	HP 00504063	101259	POWERSCHOOL GROUP LLC		2,825.00
10/14/2024	HP 00504065	101450	UHY CERTIFIED PUBLIC ACCOUNTANTS		15,375.00
10/14/2024	HP 00504066	101264	ULLIANCE INC		3,441.48
10/14/2024	HP 00504067	100395	WEINGARTZ SUPPLY COMPANY		86.97
10/15/2024	HP 00504069	101268	IDEMIA		66.25
10/15/2024	HP 00504070	101268	IDEMIA		66.25
10/15/2024	HP 00504071	101268	IDEMIA		66.25
10/15/2024	HP 00504072	101268	IDEMIA		66.25
10/15/2024	HP 00504073	101268	IDEMIA		66.25
10/15/2024	HP 00504074	101268	IDEMIA		66.25
10/15/2024	HP 00504075	101268	IDEMIA		66.25
10/15/2024	HP 00504076	101268	IDEMIA		66.25
10/15/2024	HP 00504077	101268	IDEMIA		66.25
10/15/2024	HP 00504078	101268	IDEMIA		66.25
10/28/2024	EH 00001302	100045	A & I ENTERPRISES		198,809.96
10/28/2024	EH 00001303	100351	AIRGAS GREAT LAKES		628.18
10/28/2024	EH 00001304	100550	AMAZON CAPITAL SERVICES INC	P2500133	3,493.64
10/28/2024	EH 00001305	100495	C G NEWSPAPERS		255.00
10/28/2024	EH 00001307	100431	CLARK HILL PLC		15,545.50
10/28/2024	EH 00001308	101071	DAKTRONICS INC		40.00
10/28/2024	EH 00001309	100861	FORTRESS, HEIDI		50.00
10/28/2024	EH 00001310	100503	HEMPLE, CHARLES		120.00
10/28/2024	EH 00001311	100056	HINTON, BEVERLY		50.00
10/28/2024	EH 00001312	100292	INVEST CENTERS LLC		282,687.61
10/28/2024	EH 00001313	100430	JG POLY SALES		367.40
10/28/2024	EH 00001315	100745	KSS ENTERPRISES		9,509.95
10/28/2024	EH 00001316	100520	PEDIATRIC HEALTH CONSULTANTS INC		1,502.68
10/28/2024	EH 00001317	100428	ROYAL ROOFING		939.00
10/28/2024	EH 00001318	100397	SCHOOL SPECIALTY	P2500149	1,943.73

Hazel Park Schools
Check Register by Fund
Check Date From 10/1/2024 TO 10/31/2024

Check Date	Check#	PE ID	Vendor Name	PO#	Amount
10/28/2024	EH 00001319	100515	STAFF CONNECTIONS LLC		7,619.00
10/28/2024	EH 00001320	100357	STAPLES BUSINESS ADVANTGE	P2500126	4,593.62
10/28/2024	EH 00001322	100897	TRANSPORTANT INC		4,339.00
10/28/2024	HP 00504079	101104	AMERICAN READING COMPANY INC	P2500007	3,000.00
10/28/2024	HP 00504080	100544	ASCENSION MICHIGAN EMPLOYER SOLUTIONS		279.00
10/28/2024	HP 00504081	100346	BIG D LOCK & KEY		114.00
10/28/2024	HP 00504082	100735	BURKES SPORT HAVEN	P2500053	260.00
10/28/2024	HP 00504083	100512	CHAPTER 13 TRUSTEE - T. TERRY		1,115.00
10/28/2024	HP 00504084	101457	CHEMSEARCHFE		2,124.19
10/28/2024	HP 00504085	100321	CITY OF HAZEL PARK		4,214.01
10/28/2024	HP 00504086	100517	CLAWSON PUBLIC SCHOOLS		275.00
10/28/2024	HP 00504087	100308	COCHRANE SUPPLY		151.20
10/28/2024	HP 00504089	100888	CONSTELLATION		187.18
10/28/2024	HP 00504090	100309	CONSUMERS ENERGY		110.08
10/28/2024	HP 00504091	100609	DAVID RUSKIN		556.58
10/28/2024	HP 00504092	100453	DECKER EQUIPMENT		859.71
10/28/2024	HP 00504093	101403	DETROIT RADIO LLC	P2500019	4,400.00
10/28/2024	HP 00504094	100313	DTE ENERGY		42,192.88
10/28/2024	HP 00504096	100640	FIBER LINK INC		171.75
10/28/2024	HP 00504097	100707	HARRIS, JEFFREY		40.00
10/28/2024	HP 00504098	101138	HODGSON , JASON		120.00
10/28/2024	HP 00504099	100488	HOME DEPOT CREDIT SERVICES		1,754.88
10/28/2024	HP 00504100	101224	HOPSKIPDRIVE INC		41,490.75
10/28/2024	HP 00504101	100079	INTEGRITY TESTING & SAFETY ADM		62.00
10/28/2024	HP 00504102	101329	LAKE SHORE CHEERLEADING		150.00
10/28/2024	HP 00504103	101172	LAMPHERE HIGH SCHOOL		150.00
10/28/2024	HP 00504104	101350	LUCAS, ALLISON		240.00
10/28/2024	HP 00504106	100089	MCNAUGHTON-MCKAY ELECTRIC COMP		454.76
10/28/2024	HP 00504107	100589	MILLENNIUM BUSINESS SYSTEMS		468.71
10/28/2024	HP 00504108	100387	MISDU		551.60
10/28/2024	HP 00504111	100001	OAKLAND UNIVERSITY		32,376.00

Hazel Park Schools
Check Register by Fund
Check Date From 10/1/2024 TO 10/31/2024

Check Date	Check#	PE ID	Vendor Name	PO#	Amount	
10/28/2024	HP 00504113	100497	OTIS ELEVATOR		2,932.65	
10/28/2024	HP 00504114	101456	PRIMEX WIRELESS INC		780.36	
10/28/2024	HP 00504115	101455	RPM		137.08	
10/28/2024	HP 00504116	101139	SCHEER GREEN AND BURKE CO. LPA		356.73	
10/28/2024	HP 00504117	100652	SCHOLASTIC INC	P2500118	7,706.69	
10/28/2024	HP 00504118	101372	SCHOOLCRAFT COLLEGE		3,397.00	
10/28/2024	HP 00504120	100749	SONITROL GREAT LAKES		569.43	
10/28/2024	HP 00504121	100399	STATE OF MICHIGAN - LARA		375.00	
10/28/2024	HP 00504122	100235	TOP NOTCH PRINTING LLC		650.00	
10/28/2024	HP 00504123	101439	VELO LAW OFFICE		100.00	
10/28/2024	HP 00504124	100364	VIGILANTE SECURITY INC		1,064.00	
10/28/2024	HP 00504125	100996	WILSON, SHARON		690.00	
			Fund	110	Total:	1,155,808.87
Fund: 220						
10/04/2024	EH 00001286	100550	AMAZON CAPITAL SERVICES INC	P2500106	1,278.25	
10/04/2024	HP 00504013	101104	AMERICAN READING COMPANY INC	P2500002	5,570.00	
10/04/2024	HP 00504020	101132	ENTECH MEDICALL STAFFING		557.89	
10/04/2024	HP 00504021	100446	FAR THERAPEUTIC & PERFORMING ARTS		2,531.25	
10/14/2024	EH 00001293	100802	CURRICULUM ASSOCIATES LLC	P2500068	1,389.02	
10/14/2024	HP 00504055	101132	ENTECH MEDICALL STAFFING		557.89	
10/14/2024	HP 00504061	101052	NORTHSTAR MAT SERVICE		123.15	
10/28/2024	EH 00001304	100550	AMAZON CAPITAL SERVICES INC	P2500148	1,381.43	
10/28/2024	EH 00001320	100357	STAPLES BUSINESS ADVANTGE	P2500050	658.91	
10/28/2024	HP 00504088	101459	COHEN, BASYA		408.00	
10/28/2024	HP 00504095	101132	ENTECH MEDICALL STAFFING		3,106.27	
			Fund	220	Total:	17,562.06
Fund: 230						
10/04/2024	EH 00001286	100550	AMAZON CAPITAL SERVICES INC	P2500114	266.82	
10/14/2024	EH 00001292	100550	AMAZON CAPITAL SERVICES INC	P2500124	268.38	
10/14/2024	HP 00504061	101052	NORTHSTAR MAT SERVICE		104.51	
			Fund	230	Total:	639.71

Hazel Park Schools
Check Register by Fund
Check Date From 10/1/2024 TO 10/31/2024

Check Date	Check#	PE ID	Vendor Name	PO#	Amount
Fund: 250					
10/14/2024	HP 00504059	101315	MACOMB SALES & SERVICE LLC		3,150.00
10/28/2024	EH 00001306	100118	CHARTWELLS DINING SERVICES		282,662.29
10/28/2024	HP 00504105	101315	MACOMB SALES & SERVICE LLC		1,520.40
10/28/2024	HP 00504124	100364	VIGILANTE SECURITY INC		17.50
			Fund	250	Total:
					287,350.19
Fund: 290					
10/14/2024	HP 00504046	101124	ALNET		75.00
10/14/2024	HP 00504064	100856	SHOWCASE AMERICA UNLIMITED		500.00
10/14/2024	HP 00504068	101395	WEST MUSIC COMPANY INC		1,318.00
10/28/2024	EH 00001304	100550	AMAZON CAPITAL SERVICES INC	P2500046	70.35
10/28/2024	HP 00504109	101458	MITTEN OUTDOOR ADVENTURE & EVENTS		810.00
10/28/2024	HP 00504110	100481	OAKLAND COMMUNITY COLLEGE		8,483.51
10/28/2024	HP 00504112	101196	ONE CUSTOM CITY		780.00
10/28/2024	HP 00504119	100856	SHOWCASE AMERICA UNLIMITED		150.00
			Fund	290	Total:
					12,186.86
Fund: 420					
10/28/2024	EH 00001314	100948	KINGSCOTT ASSOCIATES INC		7,299.73
10/28/2024	EH 00001321	100087	TMP ARCHITECTURE INC		4,926.08
			Fund	420	Total:
					12,225.81
			Grand Total:		1,485,773.50

68

End of Report

Huntington Bank
Commercial Card Summary (P-Card)
For Month Ending - October 2024

<u>Date of Trans</u>	<u>Card Holder</u>	<u>Vendor</u>	<u>Amount</u>
10/31/2024	CARLA BEACH	BJS WHOLESALE #383	100.41
10/17/2024	CARLA BEACH	FAMILY DOLLAR	12.72
10/17/2024	CARLA BEACH	OFFICEMAX/DEPOT 6026	81.90
10/09/2024	CARLA BEACH	AMAZON MARK* P25RT5EP3	194.20
10/23/2024	GINA BREW	SULLIVANS FLEET SERVIC	1,110.51
10/20/2024	GINA BREW	BSN SPORTS LLC	(147.19)
10/06/2024	GINA BREW	SQ *OAKLAND COUNTY TRA	75.00
10/04/2024	GINA BREW	HOLLAND MOTOR HOMES AN	168.91
10/25/2024	JAMIE BUCZKO	CROWNE PLAZA HOTELS	174.90
10/25/2024	JAMIE BUCZKO	CROWNE PLAZA HOTELS	174.90
10/25/2024	JAMIE BUCZKO	CROWNE PLAZA HOTELS	174.90
10/25/2024	JAMIE BUCZKO	AMERICAN RED CROSS	45.00
10/20/2024	JAMIE BUCZKO	NASN	154.00
10/18/2024	JAMIE BUCZKO	MICHASSOCSA	1,481.68
10/10/2024	JAMIE BUCZKO	DELTA	428.95
10/09/2024	JAMIE BUCZKO	AMERICAN ASSOC OF SCHO	795.00
10/08/2024	JAMIE BUCZKO	THE ATS STORE LLC RP	24.97
10/02/2024	JAMIE BUCZKO	OAKLAND SCHOOLS	315.00
10/02/2024	JAMIE BUCZKO	BARNES & NOBLE #2923	889.00
10/31/2024	KRISTY CALES	A 1 FINGERPRINT	75.00
10/30/2024	KRISTY CALES	A 1 FINGERPRINT	75.00
10/29/2024	KRISTY CALES	A 1 FINGERPRINT	75.00
10/29/2024	KRISTY CALES	MDE EDUCATOR LICENSE	45.00
10/29/2024	KRISTY CALES	A 1 FINGERPRINT	75.00
10/20/2024	KRISTY CALES	MDE EDUCATOR LICENSE	405.00
10/17/2024	KRISTY CALES	A 1 FINGERPRINT	75.00
10/16/2024	KRISTY CALES	A 1 FINGERPRINT	75.00
10/16/2024	KRISTY CALES	A 1 FINGERPRINT	75.00
10/15/2024	KRISTY CALES	A 1 FINGERPRINT	75.00
10/15/2024	KRISTY CALES	A 1 FINGERPRINT	75.00
10/11/2024	KRISTY CALES	A 1 FINGERPRINT	75.00
10/11/2024	KRISTY CALES	A 1 FINGERPRINT	75.00
10/10/2024	KRISTY CALES	A 1 FINGERPRINT	75.00
10/09/2024	KRISTY CALES	A 1 FINGERPRINT	75.00
10/09/2024	KRISTY CALES	A 1 FINGERPRINT	75.00
10/09/2024	KRISTY CALES	A 1 FINGERPRINT	75.00
10/08/2024	KRISTY CALES	A 1 FINGERPRINT	75.00
10/08/2024	KRISTY CALES	A 1 FINGERPRINT	75.00
10/08/2024	KRISTY CALES	A 1 FINGERPRINT	75.00
10/08/2024	KRISTY CALES	A 1 FINGERPRINT	75.00
10/02/2024	KRISTY CALES	A 1 FINGERPRINT	75.00
10/02/2024	KRISTY CALES	A 1 FINGERPRINT	75.00
10/02/2024	KRISTY CALES	A 1 FINGERPRINT	75.00
10/02/2024	KRISTY CALES	A 1 FINGERPRINT	75.00
10/01/2024	KRISTY CALES	MDE EDUCATOR LICENSE	45.00
10/01/2024	KRISTY CALES	A 1 FINGERPRINT	75.00
10/01/2024	KRISTY CALES	MDE EDUCATOR LICENSE	45.00
10/31/2024	DEBRA DIMAS	MICHAELS STORES 5073	11.98
10/31/2024	DEBRA DIMAS	WM SUPERCENTER #2559	18.72
10/31/2024	DEBRA DIMAS	LITTLE CAESARS #174	6.35
10/29/2024	DEBRA DIMAS	AMAZON MARK* 9E3XM71B3	24.99
10/28/2024	DEBRA DIMAS	AMAZON RETA* BN7FY71R3	63.18
10/28/2024	DEBRA DIMAS	AMAZON MARK* DC8V409U3	55.02
10/28/2024	DEBRA DIMAS	AMAZON MARK* QH3C70P73	175.79
10/25/2024	DEBRA DIMAS	TST*NEW YORK BAGEL - F	133.00
10/23/2024	DEBRA DIMAS	OTC BRANDS *800-875-8	160.91
10/22/2024	DEBRA DIMAS	AMAZON MKTPL*3L9CA6N13	16.49
10/22/2024	DEBRA DIMAS	AMAZON MKTPL*8W64M84M3	57.45
10/20/2024	DEBRA DIMAS	TST*NEW YORK BAGEL - F	116.40

10/17/2024	DEBRA DIMAS	EDDIES PIZZA	24.00
10/13/2024	DEBRA DIMAS	AMAZON MKTPL*OO1VJ4ES3	6.99
10/11/2024	DEBRA DIMAS	TST*NEW YORK BAGEL - F	156.30
10/10/2024	DEBRA DIMAS	SAMS CLUB #6659	87.64
10/09/2024	DEBRA DIMAS	AMAZON MARK* ST81156Y3	28.98
10/08/2024	DEBRA DIMAS	CVS/PHARMACY #08103	5.88
10/06/2024	DEBRA DIMAS	TST*NEW YORK BAGEL - F	116.40
10/27/2024	KARLA GRAESSLEY	AMAZON RETA* 3X2C92183	21.14
10/25/2024	KARLA GRAESSLEY	SAMSCLUB.COM	1,706.56
10/09/2024	KARLA GRAESSLEY	AMAZON MKTPL*SP9W07AZ3	17.16
10/06/2024	KARLA GRAESSLEY	HOLIDAY INNS	108.15
10/04/2024	KARLA GRAESSLEY	NOODLES&CO.	28.20
10/01/2024	KARLA GRAESSLEY	AMAZON.COM*GB9OE5HK3	120.93
10/30/2024	KRISTINA HERRON	EA GRAPHICS	872.00
10/29/2024	KRISTINA HERRON	PAYPAL *TENFOURTEEN	110.00
10/27/2024	KRISTINA HERRON	LITTLE CAESARS #174	68.40
10/25/2024	KRISTINA HERRON	PAYPAL *TENFOURTEEN	110.00
10/25/2024	KRISTINA HERRON	CHEERLEADING.COM	511.20
10/23/2024	KRISTINA HERRON	KROGER #447	21.15
10/23/2024	KRISTINA HERRON	PHOTODAY ORDER	142.44
10/20/2024	KRISTINA HERRON	PAYPAL *TENFOURTEEN	110.00
10/20/2024	KRISTINA HERRON	TLF*THRIFTY FLORIST	93.18
10/20/2024	KRISTINA HERRON	DOLLAR TREE	7.95
10/15/2024	KRISTINA HERRON	DICKSSPORTINGGOODS.COM	47.09
10/11/2024	KRISTINA HERRON	PAYPAL *TENFOURTEEN	110.00
10/06/2024	KRISTINA HERRON	MHSAA	216.00
10/04/2024	KRISTINA HERRON	KROGER #447	12.72
10/08/2024	JULIA KENNEDY	U OREGON ONLINE PAYMNT	49.99
10/08/2024	JULIA KENNEDY	U OREGON ONLINE PAYMNT	49.99
10/08/2024	JULIA KENNEDY	U OREGON ONLINE PAYMNT	49.99
10/23/2024	KEVIN KNOBLOCK	OAKLAND SCHOOLS	20.00
10/23/2024	KEVIN KNOBLOCK	OAKLAND SCHOOLS	20.00
10/09/2024	KEVIN KNOBLOCK	OAKLAND SCHOOLS	20.00
10/25/2024	MICHELLE KRAUSE	KENSINGTON METROPARK	90.00
10/13/2024	MICHELLE KRAUSE	WOLCOTT METROPARK	90.00
10/28/2024	HEIDI KUNZ	GFS STORE #1907	45.98
10/28/2024	HEIDI KUNZ	GFS STORE #1907	25.97
10/27/2024	HEIDI KUNZ	BJS WHOLESALE #383	44.52
10/27/2024	HEIDI KUNZ	SAMS CLUB #6659	29.46
10/25/2024	HEIDI KUNZ	AMAZON MKTPL*K24WK1UN3	105.74
10/25/2024	HEIDI KUNZ	AMAZON MARK* T05HB8343	47.99
10/25/2024	HEIDI KUNZ	AMAZON MARK* T05HB8343	35.71
10/22/2024	HEIDI KUNZ	SAMS CLUB #6659	47.84
10/22/2024	HEIDI KUNZ	SAMS CLUB #6659	18.92
10/21/2024	HEIDI KUNZ	AMAZON MARK* D02WW7HR3	181.37
10/21/2024	HEIDI KUNZ	SAMS CLUB #6659	44.74
10/21/2024	HEIDI KUNZ	SAMS CLUB #6659	36.44
10/20/2024	HEIDI KUNZ	AMZN MKTP US*SI8QY0X13	4.20
10/18/2024	HEIDI KUNZ	SAMSCLUB #6659	18.36
10/18/2024	HEIDI KUNZ	AMAZON MKTPL*BA1PD6B93	19.99
10/18/2024	HEIDI KUNZ	AMAZON MKTPL*BA1PD6B93	19.95
10/17/2024	HEIDI KUNZ	KROGER #743	18.26
10/16/2024	HEIDI KUNZ	MYBINDING.COM	80.13
10/13/2024	HEIDI KUNZ	AMAZON MKTPL*YJ65G4563	136.33
10/11/2024	HEIDI KUNZ	INCLUSIVE TLC SPECIAL	215.00
10/04/2024	HEIDI KUNZ	SAMSCLUB #6659	20.66
10/28/2024	TAMMY MCHENRY	AMAZON MKTPL*FG2GA37W3	69.57
10/28/2024	TAMMY MCHENRY	AMAZON MARK* TJ98Q46G3	130.77
10/25/2024	TAMMY MCHENRY	MUSIC THEATRE INTL	1,880.00
10/25/2024	TAMMY MCHENRY	EDUCATIONAL THEATRE AS	255.00
10/22/2024	TAMMY MCHENRY	KROGER #447	54.44
10/21/2024	TAMMY MCHENRY	AMAZON.COM*5Y26972H3	141.24
10/20/2024	TAMMY MCHENRY	AMAZON.COM*9N0KE1IQ3	39.45
10/18/2024	TAMMY MCHENRY	PAYPAL *KEVINCONNOR	115.00
10/18/2024	TAMMY MCHENRY	MUSIC THEATRE INTERNAT	95.00

10/17/2024	TAMMY MCHENRY	AMAZON MKTPL*7I2UI7YO3	46.18
10/16/2024	TAMMY MCHENRY	AMAZON MKTPL*AT6W27BV3	62.97
10/16/2024	TAMMY MCHENRY	AMZN MKTP US*MX6B63N53	127.98
10/11/2024	TAMMY MCHENRY	AMAZON MKTPL*6Q80G2FP3	111.26
10/11/2024	TAMMY MCHENRY	SAMS CLUB #6659	320.76
10/09/2024	TAMMY MCHENRY	AMAZON MKTPL*068549TQ3	11.99
10/07/2024	TAMMY MCHENRY	AMAZON MKTPL*OV7AY4V53	9.99
10/07/2024	TAMMY MCHENRY	AMAZON.COM*Z09382IC3	42.84
10/07/2024	TAMMY MCHENRY	THE HOME DEPOT #2731	319.58
10/07/2024	TAMMY MCHENRY	AMAZON.COM*IF6VA9483	23.58
10/06/2024	TAMMY MCHENRY	AMAZON MARK* 887UP3MB3	202.34
10/06/2024	TAMMY MCHENRY	SAMSCLUB #6659	143.82
10/04/2024	TAMMY MCHENRY	AMAZON MKTPL*ZF4084MC3	671.98
10/03/2024	TAMMY MCHENRY	AMAZON MARK* VT4DZ8Y63	21.99
10/02/2024	TAMMY MCHENRY	AMAZON MARK* V02ZK5MS3	23.64
10/31/2024	CORRI NASTASI	TST*NEW YORK BAGEL - F	136.35
10/31/2024	CORRI NASTASI	KROGER GIFT CARDS CS	1,330.00
10/31/2024	CORRI NASTASI	VERELLEN ORCHARDS	105.04
10/30/2024	CORRI NASTASI	WAL-MART #3487	10.98
10/30/2024	CORRI NASTASI	SP ACTIONBASEDLEARNI	483.95
10/30/2024	CORRI NASTASI	AMAZON.COM*W40WN1QU3	11.44
10/30/2024	CORRI NASTASI	AMAZON MKTPL*4H06O8YN3	30.99
10/28/2024	CORRI NASTASI	AMAZON MKTPL*7N5123GT3	97.90
10/27/2024	CORRI NASTASI	AMAZON.COM*Q76TK0FT3	10.38
10/25/2024	CORRI NASTASI	AMAZON.COM*LW0AM4LA3	24.15
10/23/2024	CORRI NASTASI	KROGER #759	60.82
10/23/2024	CORRI NASTASI	AMAZON.COM*FA0VO7O83	34.82
10/22/2024	CORRI NASTASI	AMAZON MARK* CG9TA80O3	58.97
10/20/2024	CORRI NASTASI	SAMS CLUB #6664	90.79
10/17/2024	CORRI NASTASI	TST*NEW YORK BAGEL - F	136.35
10/14/2024	CORRI NASTASI	AMAZON MARK* GU3919TZ3	42.38
10/13/2024	CORRI NASTASI	KROGER #447	9.58
10/11/2024	CORRI NASTASI	AMAZON.COM*RP8GE9G83	6.99
10/11/2024	CORRI NASTASI	AMAZON.COM*S07FE3N33	37.75
10/10/2024	CORRI NASTASI	TST*NEW YORK BAGEL - F	136.35
10/10/2024	CORRI NASTASI	AMZN MKTP US*QB48O7DU3	17.42
10/09/2024	CORRI NASTASI	SAMSCLUB #6664	12.84
10/09/2024	CORRI NASTASI	SAMS CLUB #6664	13.98
10/09/2024	CORRI NASTASI	SAMSCLUB #6664	55.96
10/07/2024	CORRI NASTASI	AMAZON MARK* 8C4TZ8TW3	60.99
10/07/2024	CORRI NASTASI	AMAZON MARK* YF4P36G53	60.99
10/06/2024	CORRI NASTASI	LITTLE CAESARS #174	86.82
10/03/2024	CORRI NASTASI	TST*NEW YORK BAGEL - F	136.35
10/01/2024	CORRI NASTASI	AMAZON MKTPL*UK8RV8GW3	14.99
10/24/2024	SHEILA OKANE	AMAZON MARK* 1M7BQ4JH3	54.22
10/23/2024	SHEILA OKANE	AMAZON MARK* DK9YK2W03	10.59
10/15/2024	SHEILA OKANE	LIBIB.COM	11.00
10/30/2024	MEGAN PAPASIAN-BROADWELL	LRP PUBLICATIONS	55.45
10/23/2024	MEGAN PAPASIAN-BROADWELL	U OF O PBIS APPS	791.65
10/31/2024	JAMES PATERSON	CARD FEE	25.00
10/27/2024	ACCOUNTS PAYABLE	AMAZON MARK* 502R91N03	41.81
10/23/2024	ACCOUNTS PAYABLE	ECOLAB INC	250.00
10/18/2024	ACCOUNTS PAYABLE	ECOLAB INC	99.11
10/18/2024	ACCOUNTS PAYABLE	ECOLAB INC	99.11
10/18/2024	ACCOUNTS PAYABLE	ECOLAB INC	274.01
10/18/2024	ACCOUNTS PAYABLE	ECOLAB INC	174.90
10/17/2024	ACCOUNTS PAYABLE	ECOLAB INC	169.07
10/17/2024	ACCOUNTS PAYABLE	ECOLAB INC	114.27
10/17/2024	ACCOUNTS PAYABLE	ECOLAB INC	99.11
10/16/2024	ACCOUNTS PAYABLE	TMOBILE*AUTO PAY	400.33
10/16/2024	ACCOUNTS PAYABLE	CORRIGAN MOVING SYSTEM	308.68
10/16/2024	ACCOUNTS PAYABLE	REPUBLIC SERVICES TRAS	217.50
10/16/2024	ACCOUNTS PAYABLE	REPUBLIC SERVICES TRAS	4,231.04
10/13/2024	ACCOUNTS PAYABLE	GRINDERZEE	110.84
10/09/2024	ACCOUNTS PAYABLE	ECOLAB INC	99.11

10/09/2024	ACCOUNTS PAYABLE	RIDDELL ALL AMERICAN	129.00
10/09/2024	ACCOUNTS PAYABLE	RIDDELL ALL AMERICAN	289.00
10/09/2024	ACCOUNTS PAYABLE	ECOLAB INC	139.92
10/09/2024	ACCOUNTS PAYABLE	ECOLAB INC	87.45
10/07/2024	ACCOUNTS PAYABLE	AMAZON MKTPL*1V75U7U93	28.97
10/07/2024	ACCOUNTS PAYABLE	AMAZON MARK* 4S2UQ8EO3	35.73
10/06/2024	ACCOUNTS PAYABLE	MPS	312.00
10/02/2024	ACCOUNTS PAYABLE	PROCARE SOFTWARE	368.00
10/01/2024	ACCOUNTS PAYABLE	ECOLAB INC	250.00
10/01/2024	ACCOUNTS PAYABLE	MPS	4,454.92
10/31/2024	GREG RICHARDSON	TONYS ACE HDWE	9.07
10/31/2024	GREG RICHARDSON	TONYS ACE HDWE	17.09
10/31/2024	GREG RICHARDSON	TONYS ACE HDWE	19.16
10/30/2024	GREG RICHARDSON	TONYS ACE HDWE	15.94
10/30/2024	GREG RICHARDSON	TONYS ACE HDWE	45.50
10/29/2024	GREG RICHARDSON	TONYS ACE HDWE	22.96
10/27/2024	GREG RICHARDSON	TONYS ACE HDWE	15.18
10/27/2024	GREG RICHARDSON	TONYS ACE HDWE	630.16
10/27/2024	GREG RICHARDSON	TONYS ACE HDWE	98.07
10/27/2024	GREG RICHARDSON	TONYS ACE HDWE	3.06
10/25/2024	GREG RICHARDSON	TONYS ACE HDWE	46.28
10/25/2024	GREG RICHARDSON	TONYS ACE HDWE	53.16
10/25/2024	GREG RICHARDSON	TONYS ACE HDWE	6.26
10/25/2024	GREG RICHARDSON	TONYS ACE HDWE	8.16
10/24/2024	GREG RICHARDSON	TONYS ACE HDWE	44.45
10/24/2024	GREG RICHARDSON	TONYS ACE HDWE	43.08
10/24/2024	GREG RICHARDSON	TONYS ACE HDWE	35.10
10/23/2024	GREG RICHARDSON	TONYS ACE HDWE	75.95
10/23/2024	GREG RICHARDSON	TONYS ACE HDWE	26.19
10/23/2024	GREG RICHARDSON	TONYS ACE HDWE	24.30
10/23/2024	GREG RICHARDSON	TONYS ACE HDWE	8.64
10/22/2024	GREG RICHARDSON	TONYS ACE HDWE	48.43
10/20/2024	GREG RICHARDSON	TONYS ACE HDWE	77.16
10/20/2024	GREG RICHARDSON	TONYS ACE HDWE	3.16
10/20/2024	GREG RICHARDSON	TONYS ACE HDWE	25.63
10/20/2024	GREG RICHARDSON	TONYS ACE HDWE	5.68
10/18/2024	GREG RICHARDSON	MICHIGAN AIR PRODUCTS	240.00
10/18/2024	GREG RICHARDSON	TONYS ACE HDWE	36.64
10/18/2024	GREG RICHARDSON	TONYS ACE HDWE	16.12
10/17/2024	GREG RICHARDSON	TONYS ACE HDWE	14.42
10/17/2024	GREG RICHARDSON	TONYS ACE HDWE	24.68
10/16/2024	GREG RICHARDSON	TONYS ACE HDWE	75.61
10/15/2024	GREG RICHARDSON	TONYS ACE HDWE	38.54
10/13/2024	GREG RICHARDSON	TONYS ACE HDWE	23.73
10/13/2024	GREG RICHARDSON	TONYS ACE HDWE	70.18
10/13/2024	GREG RICHARDSON	TONYS ACE HDWE	15.75
10/11/2024	GREG RICHARDSON	TONYS ACE HDWE	42.67
10/10/2024	GREG RICHARDSON	TONYS ACE HDWE	44.59
10/09/2024	GREG RICHARDSON	TONYS ACE HDWE	11.04
10/08/2024	GREG RICHARDSON	TONYS ACE HDWE	18.34
10/07/2024	GREG RICHARDSON	DETROIT AIR COMPRESSOR	290.12
10/06/2024	GREG RICHARDSON	TONYS ACE HDWE	41.47
10/04/2024	GREG RICHARDSON	TONYS ACE HDWE	64.57
10/04/2024	GREG RICHARDSON	TONYS ACE HDWE	186.74
10/04/2024	GREG RICHARDSON	TONYS ACE HDWE	63.62
10/03/2024	GREG RICHARDSON	TONYS ACE HDWE	28.49
10/02/2024	GREG RICHARDSON	TONYS ACE HDWE	9.11
10/02/2024	GREG RICHARDSON	TONYS ACE HDWE	30.38
10/01/2024	GREG RICHARDSON	TONYS ACE HDWE	11.38
10/01/2024	GREG RICHARDSON	TONYS ACE HDWE	42.33
10/01/2024	GREG RICHARDSON	TONYS ACE HDWE	24.60
10/31/2024	JOAN RYBINSKI	KROGER #447	73.78
10/25/2024	JOAN RYBINSKI	BJS WHOLESALE #383	221.50
10/24/2024	RAMONA SOULEYRETTE	AWL*PEARSON EDUCATION	235.32
10/22/2024	RAMONA SOULEYRETTE	DOLLAR TREE	36.25

10/22/2024	RAMONA SOULEYRETTE	IMSE	125.00
10/13/2024	RAMONA SOULEYRETTE	EVERYDAYSPEECHSLP	599.99
10/10/2024	RAMONA SOULEYRETTE	AWL*PEARSON EDUCATION	65.70
10/10/2024	RAMONA SOULEYRETTE	AWL*PEARSON EDUCATION	60.00
10/08/2024	RAMONA SOULEYRETTE	BUILDING WINGS LLC	932.85
10/06/2024	RAMONA SOULEYRETTE	AWL*PEARSON EDUCATION	121.40
10/30/2024	ROCHELLE TASSIE	AMAZON MARK* TS5O58Q13	166.42
10/27/2024	ROCHELLE TASSIE	AMAZON MKTPL*XC7QP7ED3	168.58
10/27/2024	ROCHELLE TASSIE	AMAZON MARK* AY1PZ12X3	35.99
10/27/2024	ROCHELLE TASSIE	AMAZON MARK* GP93Q7OE3	99.52
10/22/2024	ROCHELLE TASSIE	AMAZON MARK* 5D18Z7G93	263.98
10/20/2024	ROCHELLE TASSIE	AMAZON MARK* 1398Z9XL3	26.99
10/18/2024	ROCHELLE TASSIE	AMAZON.COM*533TI2PO3	79.96
10/15/2024	ROCHELLE TASSIE	AMAZON MARK* S89ON7W33	107.75
10/14/2024	ROCHELLE TASSIE	AMAZON MKTPL*J19FX17H3	192.69
10/14/2024	ROCHELLE TASSIE	AMAZON MKTPL*ZD1ZT7SU3	14.99
10/09/2024	ROCHELLE TASSIE	AMAZON MKTPL*E69OB3NQ3	304.41
10/06/2024	ROCHELLE TASSIE	AMAZON MARK* A900D5AZ3	168.50
10/04/2024	ROCHELLE TASSIE	AMAZON MKTPL*SZ5Z74Y43	14.99
10/04/2024	ROCHELLE TASSIE	AMAZON MKTPL*0245W0TW3	236.13
10/02/2024	ROCHELLE TASSIE	AMAZON MARK* 4T8XI4UH3	277.75
10/27/2024	JR VIKINGS	GRINDERZEE	82.65
10/27/2024	JR VIKINGS	LITTLE CAESARS #174	77.47
10/25/2024	JR VIKINGS	NUWAYCOMBAT	671.12
10/25/2024	JR VIKINGS	SAMS CLUB #6659	65.24
10/22/2024	JR VIKINGS	SQ *CONCESSIONS - HPS	89.00
10/17/2024	JR VIKINGS	SAMS CLUB #6659	201.08
10/06/2024	JR VIKINGS	AMAZON MKTPL*HZ9TT9133	31.48
10/02/2024	JR VIKINGS	SQ *ALLSTAR CREATIONZ	157.20
10/02/2024	JR VIKINGS	AMAZON MARK* EJ6XT34H3	9.41
10/01/2024	JR VIKINGS	MEIJER # 222	73.30
10/01/2024	JR VIKINGS	SAMSClub #6659	111.40
10/27/2024	RYANN VOSS	DECKER EQUIP SCHOOL FI	6,434.05
10/27/2024	RYANN VOSS	DECKER EQUIP SCHOOL FI	2,254.20
10/27/2024	RYANN VOSS	AMZN MKTP US*XP0VR4U23	149.99
10/24/2024	RYANN VOSS	DECKER EQUIP SCHOOL FI	4,432.60
10/24/2024	RYANN VOSS	DECKER EQUIP SCHOOL FI	5,771.35
10/24/2024	RYANN VOSS	AMAZON.COM*6774E4C83	17.99
10/23/2024	RYANN VOSS	DECKER EQUIP SCHOOL FI	1,509.35
10/23/2024	RYANN VOSS	DECKER EQUIP SCHOOL FI	2,525.15
10/16/2024	RYANN VOSS	DECKER EQUIP SCHOOL FI	2,668.69
10/13/2024	RYANN VOSS	SETON IDENTIFICATION P	231.61
10/10/2024	RYANN VOSS	DECKER EQUIP SCHOOL FI	105.15
10/08/2024	RYANN VOSS	VISTAPRINT	50.86
10/04/2024	RYANN VOSS	DECKER EQUIP SCHOOL FI	771.20
10/02/2024	RYANN VOSS	MICHASSOCSA	198.00
10/02/2024	RYANN VOSS	ALLSTATE SIGN & PLAQUE	438.70
10/01/2024	RYANN VOSS	DECKER EQUIP SCHOOL FI	599.78
10/27/2024	BRADLEY WILKINS	MICRO CENTER #055-RETA	174.95
10/27/2024	BRADLEY WILKINS	ALOHI * FAXPLUS	199.79
10/23/2024	BRADLEY WILKINS	CELLULAR GENIUS	535.60
10/20/2024	BRADLEY WILKINS	PRECISION ROLLER	64.47
10/20/2024	BRADLEY WILKINS	CDW GOVT #ZR00567492	5,000.00
10/20/2024	BRADLEY WILKINS	AMAZON MARK* 4A6BU8J93	31.48
10/18/2024	BRADLEY WILKINS	FACEBK *589LBBCH72	(10.00)
10/18/2024	BRADLEY WILKINS	IN *BERESFORD COMPANY	305.00
10/18/2024	BRADLEY WILKINS	FACEBK *CYUWXBLH72	(13.00)
10/18/2024	BRADLEY WILKINS	FACEBK *KUPUXBLH72	(9.00)
10/18/2024	BRADLEY WILKINS	FACEBK *LEZXQB4J72	(6.00)
10/18/2024	BRADLEY WILKINS	FACEBK *G78YDBQH72	(8.00)
10/18/2024	BRADLEY WILKINS	FACEBK *LQXQJC8J72	(15.00)
10/18/2024	BRADLEY WILKINS	FACEBK *NJCYQB4J72	(7.00)
10/18/2024	BRADLEY WILKINS	FACEBK *XZ3MBBCH72	(11.00)
10/18/2024	BRADLEY WILKINS	FACEBK *623ETBGH72	(16.71)
10/18/2024	BRADLEY WILKINS	FACEBK *5BEKZFY8E2	63.00

10/18/2024	BRADLEY WILKINS	FACEBK *55ZFJC8J72	(6.01)
10/17/2024	BRADLEY WILKINS	FACEBK *55ZFJC8J72	6.01
10/17/2024	BRADLEY WILKINS	FACEBK *8AKYJDC8E2	57.00
10/17/2024	BRADLEY WILKINS	AMZN MKTP US*079XF0NH3	1,175.22
10/17/2024	BRADLEY WILKINS	FACEBK *LEZXQB4J72	6.00
10/17/2024	BRADLEY WILKINS	FACEBK *NJCYQB4J72	7.00
10/17/2024	BRADLEY WILKINS	AMAZON MKTPL*2O4RL2LX3	66.07
10/17/2024	BRADLEY WILKINS	CELLULAR GENIUS	535.60
10/17/2024	BRADLEY WILKINS	FACEBK *CYUWXBLH72	13.00
10/17/2024	BRADLEY WILKINS	FACEBK *623ETBGH72	16.71
10/17/2024	BRADLEY WILKINS	FACEBK *G78YDBQH72	8.00
10/17/2024	BRADLEY WILKINS	FACEBK *KUPUXBLH72	9.00
10/17/2024	BRADLEY WILKINS	FACEBK *LQXQJC8J72	15.00
10/17/2024	BRADLEY WILKINS	FACEBK *XZ3MBBCH72	11.00
10/17/2024	BRADLEY WILKINS	FACEBK *589LBBCH72	10.00
10/16/2024	BRADLEY WILKINS	SPECTRUM WIRELESS (USA	3,437.01
10/15/2024	BRADLEY WILKINS	TEL SYSTEMS	3,938.39
10/15/2024	BRADLEY WILKINS	AMZN MKTP US*OF2YZ23O3	699.69
10/14/2024	BRADLEY WILKINS	AMAZON MARK* PB3283EY3	190.00
10/13/2024	BRADLEY WILKINS	APPLE.COM/BILL	105.99
10/11/2024	BRADLEY WILKINS	BLUE CHIP HOTEL & CASI	574.53
10/11/2024	BRADLEY WILKINS	BLUE CHIP HOTEL & CASI	278.49
10/11/2024	BRADLEY WILKINS	BLUE CHIP HOTEL & CASI	278.49
10/11/2024	BRADLEY WILKINS	BLUE CHIP HOTEL & CASI	278.49
10/09/2024	BRADLEY WILKINS	KNUCKLEHEADS SPORTS BA	84.50
10/09/2024	BRADLEY WILKINS	GALVESTON STEAKHOUSE I	150.13
10/07/2024	BRADLEY WILKINS	TST* RITZ KLUB TAVERN	53.61
10/07/2024	BRADLEY WILKINS	AMAZON MARK* ZI8WS1PF0	56.93
10/06/2024	BRADLEY WILKINS	SOUNDTRAP US INC	399.00
10/04/2024	BRADLEY WILKINS	AMAZON.COM*3M2253193	1,405.99
10/03/2024	BRADLEY WILKINS	VOXTELESYS LLC	1,562.72
10/02/2024	BRADLEY WILKINS	GOOGLE *CLOUD X46RKZ	9.67
10/01/2024	BRADLEY WILKINS	PRECISION ROLLER	102.51
10/31/2024	SHANA WILLIAMS	JAVA HUTT CAFE	8.80
10/30/2024	SHANA WILLIAMS	PAYPAL *MHHPCHAMBER	100.00
10/25/2024	SHANA WILLIAMS	TST*ANITAS KITCHEN - F	37.74
10/30/2024	DANIEL WROBBEL	SAAD WHOLESALE MEATS	374.00
10/28/2024	DANIEL WROBBEL	SAAD WHOLESALE MEATS	(499.00)
10/27/2024	DANIEL WROBBEL	THE WEBSTAUANT STORE	(52.37)
10/27/2024	DANIEL WROBBEL	THE WEBSTAUANT STORE	(0.20)
10/27/2024	DANIEL WROBBEL	THE WEBSTAUANT STORE	959.17
10/25/2024	DANIEL WROBBEL	SAAD WHOLESALE MEATS	499.00
10/22/2024	DANIEL WROBBEL	AK MOBILE NOTARY	104.73
10/22/2024	DANIEL WROBBEL	SAMSCLUB.COM	124.78
10/16/2024	DANIEL WROBBEL	GFS STORE #1907	240.44
10/16/2024	DANIEL WROBBEL	TOP NOTCH PRINTING	200.00
10/11/2024	DANIEL WROBBEL	MEIJER268 *PRODUCT	(450.72)
10/11/2024	DANIEL WROBBEL	MEIJER268 *PRODUCT	(35.00)
10/06/2024	DANIEL WROBBEL	THE WEBSTAUANT STORE	17.65
10/31/2024	LINDA YATES	WILLIAM H SADLIER	201.87
10/31/2024	LINDA YATES	OAKLAND SCHOOLS	50.00
10/29/2024	LINDA YATES	PROJECT LEAD THE WAY,	200.75
10/24/2024	LINDA YATES	GVSU WEB PAYMENTS	10.00
10/24/2024	LINDA YATES	AFP*MICHIGAN ASSOCIATI	250.00
10/24/2024	LINDA YATES	OAKLAND SCHOOLS	60.00
10/22/2024	LINDA YATES	SP HARKLA	100.00
10/22/2024	LINDA YATES	AMERICAN COUNCIL ON TH	350.00
10/17/2024	LINDA YATES	FSP*SHAPE-MICHIGAN	193.00
10/17/2024	LINDA YATES	COLLEGEBOARD WORKSHOPS	175.00
10/17/2024	LINDA YATES	SP HARKLA	125.00
10/17/2024	LINDA YATES	OAKLAND SCHOOLS	20.00
10/17/2024	LINDA YATES	OAKLAND SCHOOLS	20.00
10/16/2024	LINDA YATES	OAKLAND SCHOOLS	20.00
10/15/2024	LINDA YATES	AFP*MICHIGAN ASSOCIATI	250.00
10/13/2024	LINDA YATES	OAKLAND SCHOOLS	(25.00)

10/09/2024	LINDA YATES	OAKLAND SCHOOLS	25.00
10/09/2024	LINDA YATES	NYTIMES DISC*	4.00
10/09/2024	LINDA YATES	KROGER #602	25.00
10/09/2024	LINDA YATES	OAKLAND SCHOOLS	60.00
10/08/2024	LINDA YATES	SP ROBOLINK	553.11
10/04/2024	LINDA YATES	TOP NOTCH PRINTING	200.00
10/04/2024	LINDA YATES	KROGER #602	25.00
10/03/2024	LINDA YATES	AFP*MICHIGAN ASSOCIATI	250.00
10/01/2024	LINDA YATES	MICHIGAN ASSOCIATION O	75.00

101,744.98



Ford Administration
1620 E. Elza, Hazel Park, MI 48030 | 248-658-5200 | F: 248-544-5223
www.hazelparkschools.org

To: Dr. Amy Kruppe, Superintendent
From: Dr. Stephanie Dulmage, Assistant Superintendent of Teaching and Learning
Subject: 2024-2025 LEO Update
Date: November 18, 2024

Cultivating Leadership Capacity 2024-2025 - Update

The Cultivating Continuous Improvement (CCI) series required the Literacy Leadership Team (LLT) to analyze the current status and take action on the three essential conditions for change: systems, leadership, and coaching. These conditions are the foundation for impacting staff capacity and student outcomes. This year, districts were allowed to expand their team and focus on both literacy and math. Our Literacy Leadership Team includes an elementary principal, K-8 instructional coaches, the math curriculum coordinator, and central office leaders. To date, the LLT has engaged in the following activities:

- Participation in county-level CCI meetings on September 11th. During this meeting, our team collaborated on an action plan to target vocabulary development across the disciplines. The plan includes professional learning and coaching, and a process for collecting and analyzing students' understanding of academic and domain-specific vocabulary. This focus supports the following actions outlined in the strategic plan:
 - Implement cycles of inquiry, using improvement science and the Plan-Do-Study-Act method, to improve foundational literacy skills.
 - System-wide implementation of disciplinary literacy strategies to improve vocabulary and writing.
- Collaboration with the ISD consultants to support the implementation of ARC Core, satisfy the LEO requirements, and develop a cross-district partnership of ARC implementing districts, with specific respect to conducting cross-site labs. In February, the ISD consultants will participate in instructional walk-throughs during an ARC Leadership Learning Day. This visit satisfies a LEO requirement and allows our county-level consultants to learn more about ARC Core so they may support Hazel Park as well as surrounding districts.

Funding Source: Not Applicable

Strategic Goal Alignment:

- Curriculum & Instruction: Hazel Park Schools will develop innovative, independent, and persistent learners who think critically, communicate effectively, and positively influence the local and global community.
- Climate and Culture: The Hazel Park School District will provide a unified system of support for all students, embracing diversity, and fostering a positive school climate.





Ford Administration
1620 E. Elza, Hazel Park, MI 48030 | 248-658-5200 | F: 248-544-5223
www.hazelparkschools.org

To: Hazel Park Board of Education
From: Dr. Amy Kruppe
Subject: November Grant Updates
Date: November 11, 2024

As we continue into the school year, I would like to provide you with an update on the grants our school district has received. These grants will play a crucial role in supporting our programs and initiatives throughout the year.

Grant Updates:

1. Oakland Schools - EPIC Program:

Amount: Oakland Schools will provide funding to support district participation

Purpose: The Essential Practices in Instruction: Capacity & Coherence (EPIC2) is a multi-year initiative designed to improve 3rd-6th grade math outcomes by enhancing instructional practices and leadership. Targeted districts receive support from Oakland Schools, including professional learning, resources, and monthly collaboration with a math consultant. EPIC2 focuses on equitable teaching practices and district-wide coherence, with funding provided for resources and participation.

2. 2023 Stronger Connections Funding Cohort 2:

Amount: \$10,000

Purpose: The Title IV, Part A Stronger Connections grant budget for Hazel Park Schools supports a multi-year restorative practices initiative to create safer, healthier learning environments. Funds are allocated across key areas: personnel for training facilitators and team support, contractual services for external training, professional development including workshops and retreats, travel expenses for training access, and materials for workshops. Administrative costs cover project management and coordination. The phased budget includes \$25,000 each for the launch and initial implementation stages, followed by \$10,000 each for full and continued implementation, ensuring sustained support and quality improvement.

3. 2024-25 Community School Grant:

Amount: \$125,000

Purpose: The CDC's Drug-Free Communities (DFC) Support Program award incorporates funding requirements and conditions for Hazel Park Schools, focusing on establishing safer, drug-free environments. The budget narrative and allocation revisions must be submitted by October 30, 2024. Key personnel such as the Authorized Organization Representative, Program Director, and Project Coordinator need to be confirmed. Some budget items, including salaries and restricted supplies, require adjustments. Matching funds are essential, varying by grant year, and carryover of unobligated funds is permitted. Reporting requirements include an annual progress report and biennial core measures data, assessing students' use and perceptions of substances. Noncompliance may result in corrective actions.





4. 35j Year One and Year Two:

Amount: \$308,202

Purpose: The Strategic 35j Plan outlines key actions including ensuring all Pre-K-5 educators, including coaches and administrators, complete professional learning aligned with reading science, covering best practices in language comprehension, word recognition, and abundant reading materials. Training must be accessible both synchronously and asynchronously, with pre- and post-assessment data to monitor progress. Hazel Park Schools has chosen the American Reading Company for their Pre-K-5 curriculum and professional development. For **Year 2** funding, districts must provide evidence of 100% teacher participation in training and share the website link for curriculum posting.

5. 23H Improvement of Math

Amount: Oakland Schools will provide funding to support district participation

Purpose: Section 23h of the 2023-2024 School Aid Bill allocated \$25 million to enhance math teaching and learning, leading to Oakland Schools’ collaborative application with KRESA, MISTEM, and others, to expand Math Recovery specialists across Michigan. Hazel Park Schools received approval to train up to 14 teachers in Math Recovery's Add+VantageMR® (AVMR) 1 program, focusing on foundational numeracy for K-5 students, and to appoint one Math Recovery Specialist.

The AVMR 1 training covers diagnostic assessments, instructional strategies, individualized interventions, and data-driven instruction. The specialist training adds advanced skills in areas like place value and multi-digit operations.

Through this grant, Hazel Park gains a total benefit of \$9,380 for AVMR training, while similar training directly from the US Math Recovery Council would cost nearly \$20,000. Additional benefits include local course delivery, support from ISD consultants, and enhanced district and county relationships, which support long-term math instructional development.

Strategic Goal Alignment - The request for allocating the dollars focuses on the following

Curriculum & Instruction: Hazel Park Schools will develop innovative, independent and persistent learners who think critically, communicate effectively, and positively influence the local and global community.

Resources: The Hazel Park School District will maximize its resources to assure high quality education by fostering financial stability, preserving and utilizing quality facilities, and integrating state-of-the-art technology.

Community Relations: The Hazel Park School District through strong community relations and collaboration with all stakeholders will develop high-achieving students.

Climate and Culture: The Hazel Park School District will provide a unified system of support for all students, embracing diversity, and fostering a positive school climate.

Funding Source: N/A

Recommendation N/A

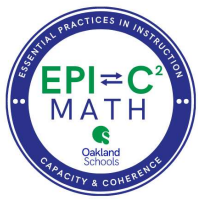

District Letter of Commitment for Participation in *EPI=C²*+

Essential Practices in Instruction \Rightarrow Capacity & Coherence (*EPI=C²*) has been developed in response to declining performance from 3rd to 6th grade on the MATHEMATICS M-STEP. *EPI=C²* is a multi-year initiative designed to increase an organization's capacity to support effective practices leading to increased student outcomes in mathematics.

EPI=C² districts with the greatest need are invited to partner with an Oakland Schools Liaison to receive more intensified support called *EPI=C²*+(pronounced EPIC Plus). Based on your district's 3rd through 6th grade mathematics M-STEP data, we invite you to partner with us

Our three goals and intended outcomes for continuous improvement:

- Enhanced, **equitable instructional practices** grounded in research (focus grades 4-6 with emphasis on 6th grade)
- Increased **confidence and efficacy of instructional leaders** (both administrative and non-administrative)
- Increased **district system coherence**

Oakland Schools Provides:	District Commits To:
<p>Professional Learning / Support</p> <ul style="list-style-type: none"> ● Support for district leaders in facilitating conversations around defining vision, goals, and action plans for mathematics instruction. ● Research-based professional learning, resources, and materials aligned with EPIC goals. ● At least six hours a month, direct support to math Non-Administrative Instructional Leader (NAIL) and/or teachers, explicitly connected to goals of EPIC with an OS math consultant. (whole group, small group, one-on-one) ● Invitation for all 4-6 grade teachers to join the EPIC Teachers Network which brings together teachers from districts receiving EPIC+ support across the county. Teachers will work toward improving their self-identified problems of practice in the context of their district's instructional vision. <p>Funding</p> <ul style="list-style-type: none"> ● Funding for stipends, substitutes, materials, resources, and professional learning opportunities to support district participation in EPIC+ activities. <p>Communication</p> <ul style="list-style-type: none"> ● At a minimum, monthly communication and updates regarding the progress towards goals of EPIC+. 	<p>Representation/Attendance</p> <ul style="list-style-type: none"> ● Participation in Cultivating Continuous Improvement (CCI) and Oakland County Mathematics Leadership Team (MLT) <ul style="list-style-type: none"> ○ CCI team includes at least one central office representative, at least one building principal and a designated Non-Administrative Instructional Leader (NAIL) in math ○ Oakland County Mathematics Leadership Team (MLT) participation - designated math NAIL ● Designating a non-administrative instructional leader (NAIL) in 4-6th grade mathematics (formal role may vary: e.g., coach, teacher, coordinator, interventionist, etc.) <p>Data</p> <ul style="list-style-type: none"> ● Collect and report required data (e.g., CCI Metrics and access to and/or evaluation of interim assessment data) to support the implementation and progress monitoring of EPIC+. <p>Engagement Support</p> <ul style="list-style-type: none"> ● Designate at least six hours a month, in district, for NAIL, with OS math consultant collaboration, to work directly with teachers connected to the goals of EPIC <p>Communication</p> <ul style="list-style-type: none"> ● Initial meeting, in summer, between OS liaison district representative, building leader, and NAIL ● Meeting and/or Communication with OS and district, building leaders

By signing this document you are in agreement with the above commitments, and want to be included in the *EPI*↔*C*²⁺ program.

Superintendent or District Designee Name: amy y kruppe

Superintendent or District Designee Signature: amy y kruppe
amy y kruppe (Oct 22, 2024 18:29 EDT)



Cover Page

**Michigan Department of Education
OFFICE OF HEALTH AND SAFETY
P.O. Box 30008
Lansing, MI 48909**

AUTHORITY: Title IV, Part A of the Elementary and Secondary Education Act of 1965 (ESEA)

Direct questions on this application to MDE-TitleIVASCG@michigan.gov.

COMPLETION: Voluntary (Consideration for funding will not be possible if form is not filed).

2023 Stronger Connections Funding Cohort 2

Entity

Entity information below is maintained in the Education Entity Master (EEM). If corrections are needed please update EEM.

Entity Name **Agreement Number**

Hazel Park, School District of the City of - 63130 *63130*

Entity Address

1620 E ELZA AVE

City **Zip Code** **Entity County**

HAZEL PARK *480302358* *Oakland County*

Main Contact Person

Contact Name

Amy kruppe

Contact information listed below is maintained in MILogin. If corrections are needed please have user update their MILogin profile.

Telephone Number

224-629-6435

Email Address

amy.kruppe@myhpsd.org

Secondary Contact Person

Contact Name

Jason Zirmis

Contact information listed below is maintained in MILogin. If corrections are needed please have user update their MILogin profile.

Telephone Number

248-586-5217

Email Address

vector.zirnis@myhpsd.org

Assurances and Certifications

Save the Page to Proceed

Assurances and Certifications

Assurances and Certifications

ASSURANCE REGARDING SANCTIONS AGAINST IRAN-LINKED BUSINESSES

The applicant assures that, for any request for proposals or contract renewal for work performed under this grant, it will collect a certification from each bidder that the bidder is not an Iran-Linked Business. An Iran-linked business is not eligible to submit a bid on a request for proposal with a public entity. Recipients must comply with all conditions under P.A. 517 of 2012, "Iran Economic Sanction Act," April 1, 2013.

ASSURANCE CONCERNING MATERIALS DEVELOPED WITH FUNDS AWARDED UNDER THIS GRANT

The grantee assures that the following statement will be included on any publication or project materials developed with funds awarded under this program, including reports, films, brochures, and flyers: "These materials were developed under a grant awarded by the Michigan Department of Education."

CERTIFICATION REGARDING NONDISCRIMINATION UNDER FEDERALLY AND STATE ASSISTED PROGRAMS

The grantee hereby agrees that it will comply with all federal and Michigan laws and regulations prohibiting discrimination and, in accordance therewith, no person, on the basis of race, color, religion, national origin or ancestry, age, sex, marital status or handicap, shall be discriminated against, excluded from participation in, denied the benefits of, or otherwise be subjected to discrimination in any program or activity for which it is responsible or for which it receives financial assistance from the U.S. Department of Education or the Michigan Department of Education.

CERTIFICATION REGARDING TITLE II OF THE AMERICANS WITH DISABILITIES ACT (ADA), P.L. 101-336, STATE AND LOCAL GOVERNMENT SERVICES

The Americans with Disabilities Act (ADA) provides comprehensive civil rights protections for individuals with disabilities. Title II of the ADA covers programs, activities, and services of public entities. Title II requires that, "No qualified individual with a disability shall, by reason of such disability be excluded from participation in or be denied the benefits of the services, programs, or activities of a public entity, or be subjected to discrimination by such entity." In accordance with Title II ADA provisions, the applicant has conducted a review of its employment and program/service delivery processes and has developed solutions to correcting barriers identified in the review.

CERTIFICATION REGARDING TITLE III OF THE AMERICANS WITH DISABILITIES ACT (ADA), P.L. 101-336, PUBLIC ACCOMMODATIONS AND COMMERCIAL FACILITIES

The Americans with Disabilities Act (ADA) provides comprehensive civil rights protections for individuals with disabilities. Title III of the ADA covers public accommodations (private entities that affect commerce, such as museums, libraries, private schools and day care centers) and only addresses existing facilities and readily achievable barrier removal. In accordance with Title III provisions, the applicant has taken the necessary action to ensure that individuals with a disability are provided full and equal access to the goods, services, facilities, privileges, advantages, or accommodations offered by the applicant. In addition, a Title III entity, upon receiving a grant from the Michigan Department of Education, is required to meet the higher standards (i.e., program accessibility standards) as set forth in Title III of the ADA for the program or service for which they receive a grant.

ASSURANCE REGARDING COMPLIANCE WITH GRANT PROGRAM REQUIREMENTS

Grantee agrees to comply with all applicable requirements of all state statutes, federal laws, executive orders, regulations, policies, and award conditions governing this program. Grantee understands and agrees that if it materially fails to comply with the terms and conditions of the grant award, the Michigan Department of Education may withhold funds otherwise due to the grantee from this grant program, any other federal grant programs or the State School Aid Act of 1979 as amended, until the grantee comes into compliance, or the matter has been adjudicated and the amount disallowed has been recaptured (forfeited). The Department may withhold up to 100 percent of any payment based on a monitoring finding, audit finding or pending final report.

Important Information

Save the Page to Proceed

Important Information

Important Information

For questions about the Stronger Connections Grant (SCG) allocations and/or this application process, contact the SCG Team at MDE-TitleIVASCG@michigan.gov.

GRANT AWARD LIMITATIONS

Is the T4PA SCG a formula or competitive grant?

The T4PA SCG is a competitive grant. The SEA, in this case MDE, must develop a T4PA SCG subgrants competition. The competition must seek applications from high-need LEAs to use funds for activities under section 4108 of the ESEA. However, MDE may design its T4PA SCG LEA subgrant competition in a manner that prioritizes a certain scope of LEA activities within the breadth of one or more specific allowable activities.

What is Michigan's definition of a high-need LEA?

Michigan defines a high-need LEA as having high rates of poverty with schools over 40% free and reduced lunch percentages, chronically absent students and exclusionary discipline, high student to mental health professional ratio, referrals to juvenile justice system, bullying/harassment, community/school violence, substance abuse or places that experienced a traumatic event.

What is MDE's application process for the T4PA SCG program?

This application will be completed in NexSys.

Which LEAs are eligible for the T4PA SCG program?

Traditional public districts, community schools and Science Technology Engineering and Mathematics (STEM) schools that received a Title IV, Part A award in State Fiscal Year 2023 are eligible to complete the T4PA SCG application. There may be some LEAs that have recently come into existence for which MDE does not have sufficient poverty, exclusionary discipline, or chronic absenteeism data to competitively score the application and therefore will not receive a T4PA SCG application.

Review Grant Selections

Stronger Connections Funding Cohort 2

Do Not Apply

Apply Now

Apply Later

[X]

Demonstration of Need

What data does the district and school currently have that shows inequities and disparities to having a safe and supportive school environment?

The data from the district reveals significant inequities and disparities impacting the safety and supportiveness of the school environment, particularly for students from economically disadvantaged and minority backgrounds. Here's a breakdown of the key insights:

Chronic Absenteeism:

Overall: 38.7% of students are chronically absent.

Racial Disparities: Chronic absenteeism affects 71.8% of Caucasian students and 73.9% of Black students, showing a disparity that impacts minority groups at a notably high rate.

Economic Disparities: A staggering 74.3% of economically disadvantaged students are chronically absent, while only 67% of students who are not economically disadvantaged face this issue. This indicates a direct correlation between economic status and absenteeism, highlighting the need for targeted support to mitigate barriers for economically disadvantaged students.

Academic Proficiency:

Reading: Only 19.2% of students reached proficiency in reading during the 2022-2023 school year. This low rate s

Math: Proficiency in math shows an even sharper gap, with only 8.8% of 8th-grade students reaching proficiency. By 11th grade, only 12.17% achieve proficiency in math, demonstrating ongoing struggles in core subjects that may hinder future educational and career opportunities.

Socioeconomic Challenges:

With over 70% of students classified as at-risk due to socioeconomic status, there is a clear indication that external challenges contribute to academic, attendance, and social engagement issues. These socioeconomic factors can directly impact students' feelings of safety and belonging in the school environment, as those who feel welcome and supported are generally more engaged and successful.

In conclusion, the data underscores the need for targeted, equitable interventions to address absenteeism, academic support, and social-emotional resources, especially for minority and economically disadvantaged students. Addressing these disparities can foster a safer, more inclusive environment that encourages engagement, attendance, and academic growth for all students.

Answers should include, but not be limited to:

1. District level data as well as building level data describing where the district plans to use the funding.
2. Data MUST be presented showing all students as well as subpopulations, inequities, and disparities:
 - Related to student discipline, climate surveys
 - Bullying/harassment
 - High rates of chronic absenteeism
 - Referrals to the juvenile justice system
 - High reports of "threatening behavior, exclusionary discipline (including incidents of seclusion and restraints, students with section 504 plans, behavior intervention plans, and/or IEPs)
 - High student to mental health professional ratio
 - Subpopulations could include, but are not limited to:
 - Gender
 - Race
 - English as a second language
 - Special needs/accommodations

What are the strengths of the district and/or buildings to leverage safe and supportive schools efforts?

Hazel Park Schools have several strengths to leverage in their efforts to create safe and supportive environments through Restorative Practices:

Commitment to Positive School Climate and Culture: The district is actively pursuing a multi-year plan focused on Restorative Practices, which have been proven to enhance school climate by fostering positive relationships, decreasing conflict, and encouraging a supportive atmosphere. This strong foundation aligns with the district's commitment to a healthy, collaborative, and inclusive school culture.

Focus on Proactive and Equitable Discipline: Hazel Park Schools' transition from punitive measures to proactive, relational approaches in handling discipline issues emphasizes equity and understanding. This proactive stance promotes inclusivity and reduces disciplinary disparities, creating a fairer environment for all students and aligning with compliance standards such as Michigan's MCL 380.1310c.

Restorative Practices Implementation Teams (RPITs): Each building's dedicated RPIT provides a strong leadership framework to guide restorative implementation effectively, allowing each school to tailor practices to their unique community and student needs. These teams support the development of social-emotional learning (SEL) competencies and a seamless integration of restorative principles into daily operations.

Structured, Stage-Based Implementation Plan: The district's four-stage implementation model—ranging from the Launch phase through to Continuous Quality Improvement—ensures that Restorative Practices are integrated progressively, with fidelity, and adjusted as needed. This staged approach provides staff with consistent training and support, enhancing confidence and competence in Restorative Practices, while gradually transforming the school climate.

Alignment with Academic and Social-Emotional Goals: By embedding Restorative Practices into the school's goals, Hazel Park Schools aim to bolster both academic performance and social-emotional growth, recognizing that students who feel valued and engaged are more likely to succeed. This dual focus reinforces the district's commitment to holistic student development and the cultivation of skills essential for both academic and personal success.

District-Wide Vision and Long-Term Support: The district's clear, data-driven vision and support for a whole-school transformation create an aligned, collective focus on safety and support across all buildings. This cohesive approach strengthens relationships among stakeholders, including students, staff, and families, laying the groundwork for a resilient, community-centered school culture.

Together, these strengths position Hazel Park Schools to be a model for creating a safe, supportive environment through Restorative Practices that promotes equity, reduces discipline gaps, and enhances students' overall learning experiences.

What are the root causes related to this specific data being provided?

ChatGPT said:

ChatGPT

The data provided reveals several root causes that contribute to the high levels of chronic absenteeism and low academic proficiency in Hazel Park Schools. Here's an analysis of the primary causes linked to these challenges:

1. Lack of Belonging and Engagement

Impact on Absenteeism: Students who do not feel a strong sense of belonging or engagement at school are more likely to be chronically absent. This is especially apparent in the significant absenteeism rates among both Black (73.9%) and Caucasian (71.8%) students, as well as economically disadvantaged students (74.3%). This suggests that many students may feel disconnected from their school environment, either culturally or socially, leading to low motivation to attend.

Impact on Academic Performance: A lack of belonging can also diminish students' willingness to engage in academic activities, reducing their effort in subjects like reading and math. This lack of engagement is likely contributing to low proficiency levels, as only 19.2% are proficient in reading, 8.8% in 8th-grade math, and 12.17% in 11th-grade math.

2. Socio-Economic Needs

Impact on Absenteeism: Economic challenges make it harder for families to provide the consistent support needed for regular school attendance. Economic stress can lead to unstable housing, food insecurity, and other factors that disproportionately affect attendance, as seen in the high absenteeism rate (74.3%) among economically disadvantaged students.

Impact on Academic Performance: Socio-economic hardships can limit students' access to resources like tutoring, books, or digital tools, all of which are crucial for academic growth. These limitations can hinder their ability to reach proficiency, particularly in subjects like reading and math, where resources for practice and extra help make a significant difference.

3. Lack of Consistent Attendance

Impact on Academic Performance: Chronic absenteeism disrupts learning continuity, affecting students' understanding and retention of essential skills. This lack of consistent attendance is evident in both the attendance and academic performance data, where high absenteeism correlates with low proficiency levels across reading and math, particularly in critical years like 8th and 11th grade. Without regular attendance, students miss out on cumulative learning experiences that are fundamental to academic progress.

4. Frequent School Changes

Impact on Absenteeism: Students who change schools often, whether due to housing instability, family circumstances, or other factors, may struggle with social integration and maintaining consistent attendance. This instability can make it harder for students to build relationships with peers and teachers, leading to an increased risk of feeling disconnected or unwelcome in new settings.

Impact on Academic Performance: School changes disrupt a student's learning flow, often leading to academic gaps and difficulties adjusting to new curricula or teaching styles. Students who experience frequent moves may miss foundational lessons, which can compound over time and result in low proficiency rates, as observed in reading and math outcomes.

Addressing these root causes requires a comprehensive approach that combines Restorative Practices, targeted support for socio-economic needs, consistent attendance initiatives, and strategies to foster a greater sense of belonging and school stability. These efforts can create a more supportive environment where students feel valued, attend regularly, and are better equipped for academic success.

Implementation Plan

Implementation plans should define and contain data and research to support the activities and programs of a safe and healthy school community. SEAs and LEAs are strongly encouraged to invest T4PA SCG funds on evidence-based interventions that have been shown to significantly improve student safety and health as well as academic outcomes. ESEA section 8101(21) defines the term “evidence-based and the definition includes four tiers of evidence.

Specifically, “evidence-based, when used with respect to an SEA, LEA, or school activity, means an activity, strategy, or intervention that demonstrates a statistically significant effect on improving student outcomes or other relevant outcomes based on:

- Strong evidence from at least one well-designed and well-implemented experimental study (“tier 1)
- Moderate evidence from at least one well-designed and well-implemented quasi-experimental study (“tier 2)
- Promising evidence from at least one well-designed and well-implemented correlational study with statistical controls for selection bias (“tier 3)
- Demonstrating a rationale based on high-quality research findings or positive evaluation that such activity, strategy, or intervention is likely to improve student outcomes or other relevant outcomes and includes ongoing efforts to examine the effects of such activity, strategy, or intervention (“tier 4)

List the objectives of the project.

The objectives of the Restorative Practices project for Hazel Park Schools are:

Enhance Social-Emotional Learning (SEL) Competencies: Develop and strengthen SEL skills among both students and staff to foster emotional awareness, empathy, and relationship-building, essential for a positive school environment.

Shift to Restorative and Proactive Practices: Transition from traditional, punitive discipline methods to restorative approaches that address conflicts constructively, support student growth, and reduce the likelihood of exclusionary discipline.

Create a Supportive School Climate and Culture: Establish an inclusive school environment that enhances relationships, reduces conflict, and supports effective teaching and learning for long-term positive impact on school climate, culture, and safety.

Close the Discipline Gap and Promote Equity: Address disparities in disciplinary actions among student populations that may face discrimination, helping to interrupt the school-to-prison pipeline and promote equitable treatment.

Improve Academic Focus and Social Development: Foster a school culture where academic goals are prioritized and aligned with students’ social development, creating a balanced and engaging learning experience for all students.

Build Collaborative Restorative Practices Implementation Teams (RPITs): Establish and support RPITs in each building, ensuring the consistent, guided implementation of restorative practices tailored to each school’s needs.

Implement a Sustainable, Multi-Year Transformation: Facilitate a whole-school climate and culture shift over several years to ensure lasting improvements in behavior, relationships, and overall school safety across all district buildings.

Summarize the activities of the project.

The project activities for implementing Restorative Practices (RP) in Hazel Park Schools span over four stages, guiding the district's transition toward a supportive, whole-school climate and culture:

Stage 1: Launch (Spring & Summer 2024)

Establish Restorative Practices Implementation Teams (RPITs) at each building to develop a vision, set goals, analyze baseline data, and define accountability.

Provide initial RP training for administrators and teachers to introduce restorative practices and plan staffing for RP support.

Key activities: Administrator training, RPIT retreat, train-the-trainer sessions, and introductory RP training for teachers.

Stage 2: Initial Implementation (Fall 2024 - Spring 2025)

Begin implementing RP in each building with ongoing support for RPIITs to set goals, review progress, and engage the community.

Regular check-ins with RPIITs to refine implementation, observe progress, and support through consultation and modeling.

Key activities: Quarterly RPIIT meetings, intermediate training for trainers, and mid-year effectiveness assessments.

Stage 3: Full Implementation (Summer 2025 - Spring 2026)

Integrate RP across all Multi-Tiered Systems of Support (MTSS) tiers, with most staff consistently applying RP practices.

RPIITs hold a retreat to plan for the new academic year and provide ongoing support to ensure RP fidelity and effectiveness.

Key activities: Annual planning retreat, training for new staff, and regular check-ins with RPIITs.

Stage 4: Continued Implementation and Continuous Quality Improvement (Summer 2026 - Spring 2027)

RPIITs focus on improving RP fidelity and outcomes, addressing obstacles, and refining practices through data analysis.

Ongoing data collection, reflection, and planning to enhance RP effectiveness and expand successful approaches.

Key activities: Annual planning retreat, continued new staff training, and routine check-ins with RPIITs.

Throughout these stages, Hazel Park Schools aim to establish a model of restorative practices that fosters safety, enhances SEL skills, boosts academic performance, and increases both staff and student engagement.

What comprehensive, evidence-based practices will be used to meet students' behavioral, physical, and mental well-being needs through positive school climates that increase access to multi-tiered supports?

To meet students' behavioral, physical, and mental well-being needs through positive school climates and to enhance access to multi-tiered supports, Hazel Park Schools will implement the following comprehensive, evidence-based practices based on Restorative Practices (RP):

1. Establishment of Restorative Practices Implementation Teams (RPITs)

Purpose: Each school will form an RPIT dedicated to overseeing the implementation of restorative practices.

Activities: These teams will assess the current school climate, identify readiness for change, and develop a vision for integrating restorative practices into daily operations.

Impact: By leading the charge for change, RPITs will promote a culture that values relationships and collaboration among all stakeholders, ensuring that student voices are heard and respected.

2. Development of Social-Emotional Learning (SEL) Competencies

Goal: To enhance the emotional and social skills of both students and staff, focusing on emotional regulation, empathy, and conflict resolution.

Implementation: RPITs will integrate SEL training into professional development, equipping staff to model and teach these competencies effectively.

Outcome: Improved SEL skills will help students feel more connected to their school community, enhancing their overall mental well-being and reducing behavioral issues.

3. Transition to Proactive Discipline Approaches

Strategy: Shift from punitive disciplinary measures to restorative practices that focus on repairing harm and building community.

Practices: Implement restorative circles and mediation to address conflicts, allowing students to understand the impact of their actions and engage in constructive dialogue.

Result: This approach will help close discipline gaps, reduce exclusionary practices, and create a safer, more supportive environment that fosters accountability.

4. Ongoing Staff Training and Support

Focus: Provide continuous professional development on restorative practices and SEL integration to ensure all staff are equipped to foster a positive school climate.

Methods: Training will include workshops, coaching, and collaborative learning opportunities tailored to the needs of educators.

Effect: Increased staff competency will lead to more effective classroom management, better student relationships, and a more cohesive approach to discipline and support.

5. Community Engagement and Support Systems

Objective: Build partnerships with families and community organizations to enhance the support network for students.

Actions: Facilitate workshops and forums to involve parents and community members in discussions about restorative practices and SEL.

Benefit: A strong community connection will provide additional resources and support for students, helping to address behavioral and mental health needs holistically.

6. Data-Driven Continuous Improvement

Approach: Regularly collect and analyze data on student behavior, attendance, and academic performance to assess the effectiveness of implemented practices.

Use of Data: This will guide adjustments to strategies and interventions, ensuring they are meeting the evolving needs of students.

Outcome: Continuous evaluation will promote a culture of accountability and improvement, ensuring that all students have equitable access to support services.

Through these comprehensive, evidence-based practices, Hazel Park Schools aim to create a positive school climate that supports the behavioral, physical, and mental well-being of all students, fostering their academic success and personal growth.

Project Adoption and Community Connections

Provide an explanation of how the district will adopt the new practices and activities.

The district will adopt new practices and activities to implement Restorative Practices (RP) through a structured, multi-year approach that emphasizes collaboration, training, and continuous improvement. Here's how the district plans to do this:

1. Formation of Restorative Practices Implementation Teams (RPITs)

Strategy: Each school will establish a dedicated RPIT to lead the implementation process. These teams will consist of educators, administrators, and community members who are committed to fostering a restorative school culture.

Activities: The RPIITs will create a vision for restorative practices, assess the current school environment, and identify strengths and areas for improvement. This collaborative effort will ensure that all voices are considered in shaping the implementation process.

2. Comprehensive Training and Professional Development

Initial Training: The district will provide initial training for all staff on restorative practices, emphasizing their importance in fostering a supportive school environment. This training will introduce the principles of RP, SEL competencies, and the transition from punitive to proactive discipline strategies.

Ongoing Support: Continuous professional development will be offered, including workshops, coaching sessions, and check-ins to support staff as they integrate these practices into their daily routines. Facilitated training will be provided by experts from the Neutral Zone, ensuring that staff feel confident and competent in their roles.

3. Implementation Stages

Structured Phases: The adoption of restorative practices will be carried out in four key stages: Launch, Initial Implementation, Full Implementation, and Continued Implementation with Continuous Quality Improvement. Each stage includes specific activities, training, and support to ensure that the implementation is effective and aligned with the district's goals.

Feedback and Reflection: At the end of each stage, RPIITs will reflect on the implementation process, assess progress, and make necessary adjustments based on data and stakeholder feedback. This iterative process will help refine practices and ensure fidelity in implementation.

4. Community Engagement and Communication

Outreach: The district will engage families and the community in the implementation process by holding informational sessions, workshops, and forums to discuss the goals and benefits of restorative practices.

Building Relationships: By fostering partnerships with community organizations, the district will create a supportive network for students, ensuring that they have access to additional resources and services that promote their well-being.

5. Data-Driven Decision Making

Baseline Data Collection: The RPIITs will identify and collect baseline data on key metrics, such as attendance, discipline referrals, and academic performance, to assess the current state of the school environment.

Monitoring Progress: The district will continuously collect and analyze data throughout the implementation process to evaluate the effectiveness of restorative practices. This data will inform ongoing adjustments to strategies and interventions, ensuring that they meet the needs of all students.

6. Alignment with District Goals

Vision Alignment: The adoption of restorative practices will align with the district's overarching goals of improving school climate, fostering positive relationships, and enhancing academic outcomes.

Support from Leadership: District leadership will actively support and advocate for the implementation of restorative practices, ensuring that resources are allocated effectively and that staff are held accountable for integrating these practices into their work.

By adopting these strategies and maintaining a commitment to restorative practices, Hazel Park Schools will create a positive, supportive environment that enhances students' behavioral, physical, and mental well-being, ultimately leading to improved academic success and personal growth.

How will the district engage students, families, educators, staff, and community organizations in selecting and implementing prevention and interventions that create safe, inclusive, and supportive learning environments?

The district will engage students, families, educators, staff, and community organizations in the selection and implementation of prevention and intervention strategies to create safe, inclusive, and supportive learning environments through a multifaceted approach that prioritizes collaboration, input, and ongoing support. Here's how this engagement will take place:

1. Inclusive Stakeholder Involvement

Restorative Practices Implementation Teams (RPITs): Each school will form RPIITs that include a diverse group of stakeholders—students, parents, teachers, administrators, and community members. These teams will work collaboratively to assess the school environment and identify the most pressing needs and effective interventions.

Regular Meetings: RPIITs will hold regular meetings that encourage open dialogue, ensuring that all voices are heard in the decision-making process regarding the selection of restorative practices and interventions.

2. Family and Community Engagement

PTA and Community Forums: The district will leverage existing structures, such as the Parent-Teacher Association (PTA) and community engagement events, to solicit input from families and community members. These forums will provide opportunities for discussions about school culture, climate, and restorative practices.

Surveys and Feedback: The district will conduct surveys to gather feedback from families and community members about their experiences and perceptions of the school environment. This information will guide the selection of interventions that meet the specific needs of the community.

3. Education and Training for Stakeholders

Training Sessions: The district will provide training sessions for educators, staff, and families on restorative practices and their importance in fostering a positive school climate. This education will empower stakeholders to understand the benefits of restorative approaches and actively participate in their implementation.

Community Workshops: The district will host workshops for community organizations to explore how they can support restorative practices in schools and engage in partnerships that enhance student well-being.

4. Data-Driven Decision Making

Analyzing Baseline Data: RPIITs will analyze current data related to student behavior, attendance, and academic performance to identify specific areas for intervention. This data will be shared with all stakeholders to promote transparency and collective understanding.

Monitoring and Adjusting Interventions: The district will continuously monitor the effectiveness of selected interventions and seek input from stakeholders to make necessary adjustments. Regular feedback loops will ensure that the implemented practices remain relevant and effective.

5. Focus on Relationship Building

Community Partnerships: The district will engage community organizations that focus on youth development, mental health, and social services. Collaborating with these organizations will provide additional resources and support for families and students.

Creating a Welcoming Environment: Schools will focus on building positive relationships among students, families, and staff, fostering a sense of belonging that encourages collaboration and participation in school activities.

6. Empowering Students

Student Leadership Opportunities: The district will create opportunities for student leadership within the RPIITs and other school committees. By empowering students to voice their perspectives and contribute to decision-making, schools can ensure that interventions are aligned with the needs and interests of the student body.

Peer Support Programs: The implementation of peer-led support programs will promote inclusivity and provide students with a platform to share their experiences, fostering a sense of community and belonging.

Conclusion

By actively engaging all stakeholders—students, families, educators, staff, and community organizations—in the selection and implementation of prevention and interventions, Hazel Park Schools will create a collaborative environment that prioritizes safety, inclusivity, and support. This comprehensive approach will enhance the overall school climate and contribute to the success and well-being of all students.

Budget Narrative

In addition to the general budget pages, a budget narrative is required to illustrate how funds will be used to achieve the goals of the Title IV, Part A Stronger Connections grant proposal.

LEA applicants are required to provide a budget narrative that supports the grant activities in the box below. All supplemental program activities and funding must support high-need LEAs to establish safer and healthier learning environments. Please summarize how the funds will be spent by each applicable category such as personnel, fringe benefits, travel, contractual services, professional development, equipment, supplies & materials, and/or administrative costs.

Budget Narrative for Title IV, Part A Stronger Connections Grant Proposal

This budget narrative outlines the proposed expenditures for the multi-year implementation of restorative practices in Hazel Park Schools, aimed at creating safer and healthier learning environments. The budget is categorized into various sections to clearly illustrate how funds will be utilized to achieve the project goals.

1. Personnel Costs

Training Facilitators: Funds will be allocated for contracted services with Neutral Zone to facilitate various training sessions, retreats, and meetings. This includes costs for administrator meetings, day-long retreats, and training of trainers.

Implementation Team Support: Compensation for staff members participating in the Restorative Practices Implementation Teams (RPITs) will be included, as their involvement is crucial to the project's success.

2. Contractual Services

Training Costs: This includes fees for the Restorative Practices Institute and related training sessions. For example:

3-Day Training of Trainers: \$12,000 (3 days at \$4,000 per day minus partner discount).

RP Institute for New Staff: \$395 per participant for any new staff enrolled in the institute.

Consultation and Support: Funds will be set aside for ongoing consultation and support from Neutral Zone to ensure the effective implementation of restorative practices across all school buildings.

3. Professional Development

Workshops and Retreats: Significant portions of the budget are dedicated to professional development, including:

Day-long Retreats: \$4,000 each for planning sessions (3 planned over the course of the project).

Quarterly Meetings: Funds will cover the costs of meetings for the RPIITs to reflect on the implementation process, assess progress, and refine practices.

Training Materials: Provision of training notebooks and guidebooks (Community Building, Circles, and Restorative Practice Strategies) to support district-wide training efforts at a cost of \$12 per set.

4. Travel Expenses

Mileage Reimbursement: Travel expenses for staff participating in training, meetings, and retreats will be reimbursed at a rate of \$0.655 per mile. This is crucial for ensuring staff can access training and support across different school buildings.

5. Supplies and Materials

Training Materials: This includes the purchase of materials for workshops and training sessions, such as handouts, guides, and any other resources needed for effective learning.

Administrative Supplies: Funds for general administrative costs associated with organizing meetings, training sessions, and community engagement activities.

6. Administrative Costs

Project Management: A portion of the budget will be allocated to cover administrative costs associated with managing the grant activities, including coordination between various stakeholders, scheduling meetings, and tracking progress.

Total Budget Summary

Stage 1: Launch: \$25,000 (excluding travel and summer enrollment costs)

Stage 2: Initial Implementation: \$25,000 (excluding travel and summer enrollment costs)

Stage 3: Full Implementation: \$10,000 (excluding travel and summer enrollment costs)

Stage 4: Continued Implementation and Quality Improvement: \$10,000 (excluding travel and summer enrollment costs)

Conclusion

The proposed budget supports the goals of establishing safer and healthier learning environments through comprehensive training and implementation of restorative practices in Hazel Park Schools. By prioritizing personnel costs, contractual services for expert facilitation, professional development opportunities, and necessary supplies, the district aims to foster a positive school climate that enhances student and staff well-being.

Evaluation and Sustainability Plan

LEA applicants must provide an evaluation plan for how the district will use team-based problem-solving and data-based decision making to monitor fidelity and evaluate outcomes that create sustainable implementation practices that continue safe and healthy activities post-grant funding.

The evaluation plan should include how the district will determine progress toward overall project objectives.

The evaluation plan for Hazel Park Schools will leverage team-based problem-solving and data-driven decision-making to monitor the fidelity of the restorative practices implementation and evaluate its outcomes. This structured approach aims to ensure sustainable practices that promote a safe and healthy learning environment beyond the grant funding period.

1. Evaluation Framework Overview

Building-Level Implementation Teams (BLITs): Each school will have dedicated teams responsible for overseeing the implementation of restorative practices. These teams will consist of educators, administrators, and support staff, ensuring a comprehensive perspective on the practices being employed.

Multi-Tiered System of Supports (MTSS) Teams: MTSS teams will be utilized to assess the efficacy of restorative practices at different tiers, focusing on universal, targeted, and intensive interventions for both behavioral and academic support.

Title I Teams: These teams will specifically monitor the impact of restorative practices on student populations that receive Title I services, ensuring that all interventions are equitable and effective.

2. Data Collection and Monitoring

SWISS Data: The School-Wide Information System (SWISS) will be utilized to collect data on student behavior, disciplinary incidents, and engagement levels. This data will be regularly reviewed to assess changes in behavior patterns and to identify areas that require additional support.

PowerSchool Data: Academic performance data from PowerSchool will be monitored to evaluate the impact of restorative practices on student achievement and engagement. This will include metrics such as attendance rates, grades, and student participation in restorative activities.

Feedback Mechanisms: Surveys and feedback forms will be distributed to students, staff, and families to gauge perceptions of the school climate and the effectiveness of restorative practices. This qualitative data will complement quantitative metrics.

3. Progress Monitoring

Regular Team Meetings: Implementation teams will meet quarterly to analyze data from SWISS and PowerSchool, discussing trends, successes, and areas for improvement. These meetings will facilitate ongoing dialogue about the fidelity of implementation and any adjustments needed to strategies.

Action Plans: Based on data reviews, teams will create action plans to address identified challenges. This iterative process will ensure that all stakeholders are actively involved in decision-making and problem-solving.

Goal Setting: Specific, measurable goals will be established at the outset of the implementation and revisited regularly. Progress toward these goals will be assessed through data analysis and team reflections.

4. Evaluating Outcomes

Fidelity of Implementation: Evaluation of fidelity will involve assessing whether restorative practices are being applied as intended. This will include observing restorative circles, reviewing documentation, and collecting feedback from participants.

Student Outcomes: The district will analyze changes in behavioral incidents, academic performance, and overall student engagement.

Improved outcomes will be evidenced by reductions in disciplinary actions, increased attendance, and higher academic achievement.

Sustainability Measures: As the grant period concludes, the district will evaluate the systems put in place to ensure sustainability. This includes training new staff, maintaining ongoing support for implementation teams, and securing funding sources for continued training and resources.

5. Reporting and Communication

Annual Reports: The district will compile annual reports summarizing findings, progress toward objectives, and recommendations for future practice. These reports will be shared with all stakeholders, including families, educators, and community partners, fostering transparency and ongoing collaboration.

Community Engagement: Engaging the broader community in understanding the evaluation results and impact of restorative practices will be essential. Community forums, newsletters, and presentations will be utilized to share successes and solicit feedback.

Conclusion

The evaluation plan for implementing restorative practices in Hazel Park Schools emphasizes a collaborative, data-driven approach that involves all stakeholders. By leveraging existing structures such as building-level implementation teams, MTSS teams, and Title I teams, the district will ensure continuous monitoring of fidelity and outcomes. This comprehensive evaluation will help to sustain effective practices beyond the grant funding, ultimately fostering a safe and healthy educational environment for all students.

How will the district evaluate process and outcome goals at the 1 year end of grant time intervals?

The evaluation plan for Hazel Park Schools will leverage team-based problem-solving and data-driven decision-making to monitor the fidelity of the restorative practices implementation and evaluate its outcomes. This structured approach aims to ensure sustainable practices that promote a safe and healthy learning environment beyond the grant funding period.

1. Evaluation Framework Overview

Building-Level Implementation Teams (BLITs): Each school will have dedicated teams responsible for overseeing the implementation of restorative practices. These teams will consist of educators, administrators, and support staff, ensuring a comprehensive perspective on the practices being employed.

Multi-Tiered System of Supports (MTSS) Teams: MTSS teams will be utilized to assess the efficacy of restorative practices at different tiers, focusing on universal, targeted, and intensive interventions for both behavioral and academic support.

Title I Teams: These teams will specifically monitor the impact of restorative practices on student populations that receive Title I services, ensuring that all interventions are equitable and effective.

2. Data Collection and Monitoring

SWISS Data: The School-Wide Information System (SWISS) will be utilized to collect data on student behavior, disciplinary incidents, and engagement levels. This data will be regularly reviewed to assess changes in behavior patterns and to identify areas that require additional support.

PowerSchool Data: Academic performance data from PowerSchool will be monitored to evaluate the impact of restorative practices on student achievement and engagement. This will include metrics such as attendance rates, grades, and student participation in restorative activities.

Feedback Mechanisms: Surveys and feedback forms will be distributed to students, staff, and families to gauge perceptions of the school climate and the effectiveness of restorative practices. This qualitative data will complement quantitative metrics.

3. Progress Monitoring

Regular Team Meetings: Implementation teams will meet quarterly to analyze data from SWISS and PowerSchool, discussing trends, successes, and areas for improvement. These meetings will facilitate ongoing dialogue about the fidelity of implementation and any adjustments needed to strategies.

Action Plans: Based on data reviews, teams will create action plans to address identified challenges. This iterative process will ensure that all stakeholders are actively involved in decision-making and problem-solving.

Goal Setting: Specific, measurable goals will be established at the outset of the implementation and revisited regularly. Progress toward these goals will be assessed through data analysis and team reflections.

4. Evaluating Outcomes

Fidelity of Implementation: Evaluation of fidelity will involve assessing whether restorative practices are being applied as intended. This will include observing restorative circles, reviewing documentation, and collecting feedback from participants.

Student Outcomes: The district will analyze changes in behavioral incidents, academic performance, and overall student engagement. Improved outcomes will be evidenced by reductions in disciplinary actions, increased attendance, and higher academic achievement.

Sustainability Measures: As the grant period concludes, the district will evaluate the systems put in place to ensure sustainability. This includes training new staff, maintaining ongoing support for implementation teams, and securing funding sources for continued training and resources.

5. Reporting and Communication

Annual Reports: The district will compile annual reports summarizing findings, progress toward objectives, and recommendations for future practice. These reports will be shared with all stakeholders, including families, educators, and community partners, fostering transparency and ongoing collaboration.

Community Engagement: Engaging the broader community in understanding the evaluation results and impact of restorative practices will be essential. Community forums, newsletters, and presentations will be utilized to share successes and solicit feedback.

Conclusion

The evaluation plan for implementing restorative practices in Hazel Park Schools emphasizes a collaborative, data-driven approach that involves all stakeholders. By leveraging existing structures such as building-level implementation teams, MTSS teams, and Title I teams, the district will ensure continuous monitoring of fidelity and outcomes. This comprehensive evaluation will help to sustain effective practices beyond the grant funding, ultimately fostering a safe and healthy educational environment for all students.

Participation of Private Schools

[X]

The District Has:

- NO private schools within the district boundary

OR:

The District Has:

- Private schools within the district boundaries but NONE are participating AND,
- Sent timely and appropriate invitations to all eligible private schools and has retained evidence of the invitations and the private school officials' response.

OR:

The District Has:

- Private schools within the district boundary that are participating the Title IV, Part A Stronger Connections Grant AND,
- Engaged in timely and meaningful consultation with each participating private school.

Budget Summary

Instructions:

- Budget Summary provides a compile of the budget items
- As appropriate, an individual program Budget Summary may display the following line(s): Allocations, Administrative Costs, Carryover, Indirect Costs
- If Indirect Costs are allowable, enter the amount in the textbox provided on this page
- Contact Information section: list individuals responsible for completing the budget section
- Completion of the Budget Summary is required for submission
- To add budget items, select the Budget Items page link in the side navigation menu
- The Budget Detail link provides a complete list of all individual budget items
- Some Program Offices may use the Flag Budget Item functionality to communicate allowability on specific budget items.
 - If Flag Budget Items are utilized, those pages are located in the budget section of the side navigation menu

Funding Source

Michigan Title IV, Part A: Stronger Connections

Agreement Number	Program Number	Project Number	CFDA Number	Starting Date	Ending Date	Fiscal Year
63130	234014	SCG25	84.424F	10/01/2023	09/30/2026	2025 99

Function Codes	Salaries 1000	Benefits 2000	Purchased Services 3000, 4000	Supplies & Materials 5000	Capital Outlay 6000	Other Expenses 7000, 8000	Total
----------------	------------------	------------------	-------------------------------------	---------------------------------	---------------------------	---------------------------------	-------

220 - Support Services - Instructional Staff	\$0	\$0	\$14,000	\$0	\$0	\$0	\$14,000
----------------------------------------------	-----	-----	----------	-----	-----	-----	----------

SUBTOTAL	\$0	\$0	\$14,000	\$0	\$0	\$0	\$14,000
----------	-----	-----	----------	-----	-----	-----	----------

Grant Member Indirect Total \$

Indirect Costs **Maximum Indirect Allowed**

\$268

Max allowed: 3.22% \$451

TOTAL	\$0	\$0	\$14,000	\$0	\$0	\$0	\$14,268
--------------	-----	-----	----------	-----	-----	-----	----------

Administrative Cost Percent 1.91%

Contact Information

***Business Office Representative**

***Phone**

***Email**

Jason Zirn

(224) 629-6435

jason.zirn@myhpsd.org

***Project Contact Person**

***Phone**

***Email**

Amy Kruppe

(224) 629-6435

amy.kruppe@myhpsd.org

Budget Item

Instructions:

- To add a Budget Item complete all fields on the page (fields will vary based on Program requirements)
- Once all budget item fields have been completed, click **Save**
 - If errors exist, an error message will be displayed
- To add another Budget Item, click **Add** in the upper right-hand corner of the Budget Item screen
 - Repeat this process until all budget items are added
- To update an existing Budget Item, navigate to the budget item through the Budget Items pop-out menu (on the side navigation menu), select Budget Item, update as appropriate, and click **Save**
- To delete a Budget Item, navigate to the appropriate budget item and click **Delete** in the upper right-hand corner of the Budget Item screen

Funding Source

<i>Michigan Title IV, Part A: Stronger Connections</i>					
Program Number	Project Number	CFDA Number	Starting Date	Ending Date	Fiscal Year
234014	SCG25	84.424F	10/01/2023	09/30/2026	2025

Select the appropriate Function Code for this budget item:

101

221: *Improvement of Instruction*

Provide a specific description for this budget item. Do not repeat the Function Code description selected in the drop down menu or the heading(s) of the box(es) used below:

administrative meeting to support training of restorative practices

Enter the dollar amount associated with the budget item. Enter an amount in only one box unless the item is Personnel. Personnel must have both Salaries and Benefits. To enter Capital Outlay, use the link for Capital Outlay.

Salaries	Benefits	Purchased Services	Supplies & Materials	Other Expenses	Total
(1000)	(2000)	(3000,4000)	(5000)	(7000,8000)	
\$	\$	\$1,000	\$	\$	\$1,000
FTE		Hours			

Flag	Comment	Previous Total	Change +/-
		\$0	\$0

Budget Item

Instructions:

- To add a Budget Item complete all fields on the page (fields will vary based on Program requirements)
- Once all budget item fields have been completed, click **Save**
 - If errors exist, an error message will be displayed
- To add another Budget Item, click **Add** in the upper right-hand corner of the Budget Item screen
 - Repeat this process until all budget items are added
- To update an existing Budget Item, navigate to the budget item through the Budget Items pop-out menu (on the side navigation menu), select Budget Item, update as appropriate, and click **Save**
- To delete a Budget Item, navigate to the appropriate budget item and click **Delete** in the upper right-hand corner of the Budget Item screen

Funding Source

<i>Michigan Title IV, Part A: Stronger Connections</i>					
Program Number	Project Number	CFDA Number	Starting Date	Ending Date	Fiscal Year
234014	SCG25	84.424F	10/01/2023	09/30/2026	2025

Select the appropriate Function Code for this budget item:

103

221: Improvement of Instruction

Provide a specific description for this budget item. Do not repeat the Function Code description selected in the drop down menu or the heading(s) of the box(es) used below:

Quarterly meetings with building implementation team . Elementary and secondary meeting individually.

Enter the dollar amount associated with the budget item. Enter an amount in only one box unless the item is Personnel. Personnel must have both Salaries and Benefits. To enter Capital Outlay, use the link for Capital Outlay.

Salaries	Benefits	Purchased Services	Supplies & Materials	Other Expenses	Total
(1000)	(2000)	(3000,4000)	(5000)	(7000,8000)	
\$	\$	\$1,000	\$	\$	\$1,000
FTE		Hours			

Flag	Comment	Previous Total	Change +/-
		\$0	\$0

Budget Item

Instructions:

- To add a Budget Item complete all fields on the page (fields will vary based on Program requirements)
- Once all budget item fields have been completed, click **Save**
 - If errors exist, an error message will be displayed
- To add another Budget Item, click **Add** in the upper right-hand corner of the Budget Item screen
 - Repeat this process until all budget items are added
- To update an existing Budget Item, navigate to the budget item through the Budget Items pop-out menu (on the side navigation menu), select Budget Item, update as appropriate, and click **Save**
- To delete a Budget Item, navigate to the appropriate budget item and click **Delete** in the upper right-hand corner of the Budget Item screen

Funding Source

<i>Michigan Title IV, Part A: Stronger Connections</i>					
Program Number	Project Number	CFDA Number	Starting Date	Ending Date	Fiscal Year
234014	SCG25	84.424F	10/01/2023	09/30/2026	2025

Select the appropriate Function Code for this budget item:

105

221: Improvement of Instruction

Provide a specific description for this budget item. Do not repeat the Function Code description selected in the drop down menu or the heading(s) of the box(es) used below:

midyear reflection and feedback for changes and additional content with administration

Enter the dollar amount associated with the budget item. Enter an amount in only one box unless the item is Personnel. Personnel must have both Salaries and Benefits. To enter Capital Outlay, use the link for Capital Outlay.

Salaries	Benefits	Purchased Services	Supplies & Materials	Other Expenses	Total
(1000)	(2000)	(3000,4000)	(5000)	(7000,8000)	
\$	\$	\$1,000	\$	\$	\$1,000
FTE		Hours			

Flag	Comment	Previous Total	Change +/-
		\$0	\$0

Budget Item

Instructions:

- To add a Budget Item complete all fields on the page (fields will vary based on Program requirements)
- Once all budget item fields have been completed, click **Save**
 - If errors exist, an error message will be displayed
- To add another Budget Item, click **Add** in the upper right-hand corner of the Budget Item screen
 - Repeat this process until all budget items are added
- To update an existing Budget Item, navigate to the budget item through the Budget Items pop-out menu (on the side navigation menu), select Budget Item, update as appropriate, and click **Save**
- To delete a Budget Item, navigate to the appropriate budget item and click **Delete** in the upper right-hand corner of the Budget Item screen

Funding Source

<i>Michigan Title IV, Part A: Stronger Connections</i>					
Program Number	Project Number	CFDA Number	Starting Date	Ending Date	Fiscal Year
234014	SCG25	84.424F	10/01/2023	09/30/2026	2025

Select the appropriate Function Code for this budget item:

107

221: Improvement of Instruction

Provide a specific description for this budget item. Do not repeat the Function Code description selected in the drop down menu or the heading(s) of the box(es) used below:

2 quarter BIT team meetings.

Enter the dollar amount associated with the budget item. Enter an amount in only one box unless the item is Personnel. Personnel must have both Salaries and Benefits. To enter Capital Outlay, use the link for Capital Outlay.

Salaries	Benefits	Purchased Services	Supplies & Materials	Other Expenses	Total
(1000)	(2000)	(3000,4000)	(5000)	(7000,8000)	
\$	\$	\$1,000	\$	\$	\$1,000
FTE		Hours			

Flag	Comment	Previous Total	Change +/-
		\$0	\$0

Budget Item

Instructions:

- To add a Budget Item complete all fields on the page (fields will vary based on Program requirements)
- Once all budget item fields have been completed, click **Save**
 - If errors exist, an error message will be displayed
- To add another Budget Item, click **Add** in the upper right-hand corner of the Budget Item screen
 - Repeat this process until all budget items are added
- To update an existing Budget Item, navigate to the budget item through the Budget Items pop-out menu (on the side navigation menu), select Budget Item, update as appropriate, and click **Save**
- To delete a Budget Item, navigate to the appropriate budget item and click **Delete** in the upper right-hand corner of the Budget Item screen

Funding Source

<i>Michigan Title IV, Part A: Stronger Connections</i>					
Program Number	Project Number	CFDA Number	Starting Date	Ending Date	Fiscal Year
234014	SCG25	84.424F	10/01/2023	09/30/2026	2025

Select the appropriate Function Code for this budget item:

109

221: *Improvement of Instruction*

Provide a specific description for this budget item. Do not repeat the Function Code description selected in the drop down menu or the heading(s) of the box(es) used below:

spring meeting with impementation team @1000 to support quarterly reviews

Enter the dollar amount associated with the budget item. Enter an amount in only one box unless the item is Personnel. Personnel must have both Salaries and Benefits. To enter Capital Outlay, use the link for Capital Outlay.

Salaries	Benefits	Purchased Services	Supplies & Materials	Other Expenses	Total
(1000)	(2000)	(3000,4000)	(5000)	(7000,8000)	
\$	\$	\$1,000	\$	\$	\$1,000
FTE		Hours			

Flag	Comment	Previous Total	Change +/-
		\$0	\$0

Budget Item

Instructions:

- To add a Budget Item complete all fields on the page (fields will vary based on Program requirements)
- Once all budget item fields have been completed, click **Save**
 - If errors exist, an error message will be displayed
- To add another Budget Item, click **Add** in the upper right-hand corner of the Budget Item screen
 - Repeat this process until all budget items are added
- To update an existing Budget Item, navigate to the budget item through the Budget Items pop-out menu (on the side navigation menu), select Budget Item, update as appropriate, and click **Save**
- To delete a Budget Item, navigate to the appropriate budget item and click **Delete** in the upper right-hand corner of the Budget Item screen

Funding Source

<i>Michigan Title IV, Part A: Stronger Connections</i>					
Program Number	Project Number	CFDA Number	Starting Date	Ending Date	Fiscal Year
234014	SCG25	84.424F	10/01/2023	09/30/2026	2025

Select the appropriate Function Code for this budget item:

111

221: *Improvement of Instruction*

Provide a specific description for this budget item. Do not repeat the Function Code description selected in the drop down menu or the heading(s) of the box(es) used below:

full day training of all certified staff on restorative practices in the classroom . November 5th.

Enter the dollar amount associated with the budget item. Enter an amount in only one box unless the item is Personnel. Personnel must have both Salaries and Benefits. To enter Capital Outlay, use the link for Capital Outlay.

Salaries	Benefits	Purchased Services	Supplies & Materials	Other Expenses	Total
(1000)	(2000)	(3000,4000)	(5000)	(7000,8000)	
\$	\$	\$4,000	\$	\$	\$4,000
FTE		Hours			

Flag	Comment	Previous Total	Change +/-
		\$0	\$0

Budget Item

Instructions:

- To add a Budget Item complete all fields on the page (fields will vary based on Program requirements)
- Once all budget item fields have been completed, click **Save**
 - If errors exist, an error message will be displayed
- To add another Budget Item, click **Add** in the upper right-hand corner of the Budget Item screen
 - Repeat this process until all budget items are added
- To update an existing Budget Item, navigate to the budget item through the Budget Items pop-out menu (on the side navigation menu), select Budget Item, update as appropriate, and click **Save**
- To delete a Budget Item, navigate to the appropriate budget item and click **Delete** in the upper right-hand corner of the Budget Item screen

Funding Source

<i>Michigan Title IV, Part A: Stronger Connections</i>					
Program Number	Project Number	CFDA Number	Starting Date	Ending Date	Fiscal Year
234014	SCG25	84.424F	10/01/2023	09/30/2026	2025

Select the appropriate Function Code for this budget item:

113

221: *Improvement of Instruction*

Provide a specific description for this budget item. Do not repeat the Function Code description selected in the drop down menu or the heading(s) of the box(es) used below:

Day long retreat for team to plan 2025-2026

Enter the dollar amount associated with the budget item. Enter an amount in only one box unless the item is Personnel. Personnel must have both Salaries and Benefits. To enter Capital Outlay, use the link for Capital Outlay.

Salaries	Benefits	Purchased Services	Supplies & Materials	Other Expenses	Total
(1000)	(2000)	(3000,4000)	(5000)	(7000,8000)	
\$	\$	\$5,000	\$	\$	\$5,000
FTE		Hours			

Flag	Comment	Previous Total	Change +/-
		\$0	\$0

Flagged Budget Items

Instructions:

- Flagged Budget Items displays the budget items in detail
- If Flagged Budget Item has been used by the Program Office Reviewer, a flag for allowability of the individual budget item will be displayed in the flag field along with any comments
- Budget Item detail can be accessed by clicking the function code link
- Availability to update flagged budget items is dependent on the flag for the individual budget item and application status:
 - Modifications Required:
 - Recipients must first change the application status to a Modifications in Progress Status
 - Unallowable budget items must be deleted from the budget section
 - Modifications required budget items must be updated appropriately based on comments provided by the Reviewer
 - Approved budget items are locked and will not allow edits
 - Amendment In Progress:
 - All budget items are available to update as allowable by program guidelines

Flagged Budget Items

Entity

Hazel Park, School District of the City of - 63130

Flag	Comment	Function Code	Description	Salaries	Benefits	Purchased Services	Supplies & Materials	Capital Outlay	Other	Total
		221: Improvement of Instruction	administrative meeting to support training of restorative practices	\$0	\$0	\$1000	\$0	\$0	\$0	\$1000
		221: Improvement of Instruction	Quarterly meetings with building implementation team .	\$0	\$0	\$1000	\$0	\$0	\$0	\$1000
		221: Improvement of Instruction	Elementary and secondary meeting individually. full day training of all certified staff on restorative practices in the classroom . November 5th.	\$0	\$0	\$4000	\$0	\$0	\$0	\$4000

<u>221: Improvement of Instruction</u>	<i>midyear reflection and feedback for changes and additional content with administration</i>	\$0	\$0	\$1000	\$0	\$0	\$0	\$1000
<u>221: Improvement of Instruction</u>	<i>2 quarter BIT team meetings.</i>	\$0	\$0	\$1000	\$0	\$0	\$0	\$1000
<u>221: Improvement of Instruction</u>	<i>spring meeting with impementation team @1000 to support quarterly reviews</i>	\$0	\$0	\$1000	\$0	\$0	\$0	\$1000
<u>221: Improvement of Instruction</u>	<i>Day long retreat for team to plan 2025-2026</i>	\$0	\$0	\$5000	\$0	\$0	\$0	\$5000

Total \$14000

Approved Total \$

Modifications Required Total \$

Unallowable Total \$



Recipient Information

1. Recipient Name

HAZEL PARK SCHOOL DISTRICT
1620 E Elza Ave
Community Schools
Hazel Park, MI 48030-2358

2. Congressional District of Recipient

11

3. Payment System Identifier (ID)

1386003088A2

4. Employer Identification Number (EIN)

386003088

5. Data Universal Numbering System (DUNS)

6. Recipient's Unique Entity Identifier (UEI)

WUTWHMJLM7L5

7. Project Director or Principal Investigator

Dr. Stephanie Dulmage
Program Director
stephanie.dulmage@myhpsd.org
248-658-5234

8. Authorized Official

Mr. Jason Zirniss
AOR
jason.zirniss@myhpsd.org
248-658-5234

Federal Agency Information

CDC Office of Financial Resources

9. Awarding Agency Contact Information

Mr. Dervin Capers
Grant Management Specialist
GTE1@cdc.gov
7704882523

10. Program Official Contact Information

Bianca Anderson
Public Health Advisor
qky4@cdc.gov
404-498-2089

Federal Award Information

11. Award Number

5 NH28CE003608-02-00

12. Unique Federal Award Identification Number (FAIN)

NH28CE003608

13. Statutory Authority

Drug-Free Communities Act, 21 USC 1531 et seq., P.L. 105-20

14. Federal Award Project Title

Hazel Park Community Coalition Drug Free Communities Grant 2023

15. Assistance Listing Number

93.276

16. Assistance Listing Program Title

Drug-Free Communities Support Program Grants

17. Award Action Type

Non-Competing Continuation

18. Is the Award R&D?

No

Summary Federal Award Financial Information

19. Budget Period Start Date	09/30/2024	- End Date	09/29/2025
20. Total Amount of Federal Funds Obligated by this Action			\$125,000.00
20a. Direct Cost Amount			\$125,000.00
20b. Indirect Cost Amount			\$0.00
21. Authorized Carryover			\$0.00
22. Offset			\$0.00
23. Total Amount of Federal Funds Obligated this budget period			\$0.00
24. Total Approved Cost Sharing or Matching, where applicable			\$125,000.00
25. Total Federal and Non-Federal Approved this Budget Period			\$250,000.00
26. Period of Performance Start Date	09/30/2023	- End Date	09/29/2028
27. Total Amount of the Federal Award including Approved Cost Sharing or Matching this Period of Performance			\$500,000.00

28. Authorized Treatment of Program Income

ADDITIONAL COSTS

29. Grants Management Officer - Signature

Kevin Heath
Grants Management Specialist

30. Remarks



Recipient Information
Recipient Name HAZEL PARK SCHOOL DISTRICT 1620 E Elza Ave Community Schools Hazel Park, MI 48030-2358
Congressional District of Recipient 11
Payment Account Number and Type 1386003088A2
Employer Identification Number (EIN) Data 386003088
Universal Numbering System (DUNS)
Recipient's Unique Entity Identifier (UEI) WUTWHMJLM7L5
31. Assistance Type Project Grant
32. Type of Award Other

33. Approved Budget (Excludes Direct Assistance)	
I. Financial Assistance from the Federal Awarding Agency Only	
II. Total project costs including grant funds and all other financial participation	
a. Salaries and Wages	\$71,250.00
b. Fringe Benefits	\$28,500.00
c. Total Personnel Costs	\$99,750.00
d. Equipment	\$0.00
e. Supplies	\$6,000.00
f. Travel	\$4,750.00
g. Construction	\$0.00
h. Other	\$0.00
i. Contractual	\$14,500.00
j. TOTAL DIRECT COSTS	\$125,000.00
k. INDIRECT COSTS	\$0.00
l. TOTAL APPROVED BUDGET	\$125,000.00
m. Federal Share	\$125,000.00
n. Non-Federal Share	\$125,000.00

34. Accounting Classification Codes						
FY-ACCOUNT NO.	DOCUMENT NO.	ADMINISTRATIVE CODE	OBJECT CLASS	CFDA NO.	AMT ACTION FINANCIAL ASSISTANCE	APPROPRIATION
4-9390LJF	23NH28CE003608	CE	410U	93.276	\$125,000.00	75-24-0943



DEPARTMENT OF HEALTH AND HUMAN SERVICES Notice of Award

Centers for Disease Control and Prevention

Award# 5 NH28CE003608-02-00

FAIN# NH28CE003608

Federal Award Date: 09/19/2024

Direct Assistance

BUDGET CATEGORIES	PREVIOUS AMOUNT (A)	AMOUNT THIS ACTION (B)	TOTAL (A + B)
Personnel	\$0.00	\$0.00	\$0.00
Fringe Benefits	\$0.00	\$0.00	\$0.00
Travel	\$0.00	\$0.00	\$0.00
Equipment	\$0.00	\$0.00	\$0.00
Supplies	\$0.00	\$0.00	\$0.00
Contractual	\$0.00	\$0.00	\$0.00
Construction	\$0.00	\$0.00	\$0.00
Other	\$0.00	\$0.00	\$0.00
Total	\$0.00	\$0.00	\$0.00

AWARD ATTACHMENTS

HAZEL PARK SCHOOL DISTRICT

5 NH28CE003608-02-00

1. Terms and Conditions

Budget Period: 02
Fiscal Agent Name: Hazel Park Schools
Coalition Name: Hazel Park Community Coalition

AWARD INFORMATION

Incorporation: In addition to the federal laws, regulations, policies, and CDC General Terms and Conditions for Non-research awards at <https://www.cdc.gov/grants/federal-regulations-policies/index.html>, the Centers for Disease Control and Prevention (CDC) hereby incorporates Notice of Funding Opportunity (NOFO) number CDC-RFA-CE23-0004, entitled Drug-Free Communities (DFC) Support Program, and application dated March 13, 2024, as may be amended, which are hereby made a part of this Non-research award, hereinafter referred to as the Notice of Award (NOA).

Total Approved Funding is included in Summary Federal Award Financial Information on page 1 of the NOA. All future year funding will be based on satisfactory programmatic progress and the availability of funds.

The federal award amount is subject to adjustment based on total allowable costs incurred and/or the value of any third-party in-kind contribution when applicable.

Note: Refer to the Payment Information section for Payment Management System (PMS) subaccount information.

Financial Assistance Mechanism: Grant

Key Personnel: In addition to the Principal Investigator/Project Director identified in this Notice of Award, the application and work plan included individuals considered key personnel. In accordance 45 CFR Part 75.308, the recipient must request prior approval from CDC to change the following individual/position:

Jason Zirnis – Authorized Organization Representative
TBD – Program Director/Principal Investigator
TBD – Project Coordinator

Budget Revision Requirement: By October 30, 2024 the recipient must submit a revised budget with a narrative justification. Failure to submit the required information in a timely manner may adversely affect the future funding of this project. If the information cannot be provided by the due date, you are required to contact the GMS/GMO identified in the CDC Staff Contacts section of this notice before the due date.

Expanded Authority: The recipient is permitted the following expanded authority in the administration of the award.

- Carryover of unobligated balances from one budget period to a subsequent budget period. Unobligated funds may be used for purposes within the scope of the project as originally approved. Recipients will report use, or intended use, of carried over unobligated funds in Section 12 "Remarks" of the annual Federal Financial Report. If the GMO determines that some or all of the unobligated funds are not necessary to complete the project, the GMO may restrict the recipient's authority to automatically carry over unobligated balances in the future, use the balance to reduce or offset CDC funding for a subsequent budget period, or use a combination of these actions.

FUNDING RESTRICTIONS AND LIMITATIONS

Administrative Restrictions:

SALARIES (Federal): Calculation is incorrect. Re-calculate level of effort times the salary rate, then submit a revised budget. The revised budget must be submitted via GrantSolutions as an amendment and GMO approval is provided via Notice of Award.

PERSONNEL – The names of the correct key personnel are not identified on the budget. The recipient must update the budget with the names of the current Authorized Organization Representative, Principal Investigator and identify the Project Coordinator. The revised budget must be submitted via GrantSolutions as an amendment and GMO approval is provided via Notice of Award.

Programmatic Restrictions:

SUPPLIES (Federal): Restricting \$1000 for gift cards and other rewards. Need to ensure that the gift cards are not more than \$30 per person. Program Officer recommends a revised budget. The revised budget must be submitted via GrantSolutions as an amendment and GMO approval is provided via Notice of Award.

OTHER (Federal): Restricting \$500 for Other. Based on categories, federal budget narrative categories total is \$125,500 and not \$125,000. Program Officer recommends a revised budget to deduct \$500 from this category. The revised budget must be submitted via GrantSolutions as an amendment and GMO approval is provided via Notice of Award.

Unallowable Cost: The following item of cost has been added to the DFC Funding Restrictions. All other terms and conditions issued with the original award remain in effect throughout the budget period unless otherwise changed, in writing, by the Grants Management Officer.

- **Vaping Detection Devices:** DFC funds may not be used for Vaping Detection Devices.

Indirect Costs:

Indirect costs are not approved for this award, because indirect costs were not requested, or an approved Indirect Cost Rate Agreement has not been established. To have indirect costs approved for this grant, submit an approved indirect cost rate agreement to the grants management specialist no later than October 30, 2024.

Missing Contractual Elements – The contracts listed below are not approved and the recipient may not begin the contract until *Name of Contractors* are provided via Grant Solutions as a Notification of Contractor amendment and GMO approval is provided via Notice of Award.

Contractor 2 – Speakers for Substance Abuse Education
Contractor 3 – Speakers and Trainers Substance Use Programming

Matching Funds Requirement: The required level of non-federal participation for the Drug Free Communities Grant Program is listed below:.

Grant Year	Matching Requirement
1-6	100%
7-8	125%
9-10	150%

Matching is generally calculated on the basis of the federal award amount and is comprised of recipient contributions proposed to support anticipated costs of the project during a specific budget period (confirmation of the existence of funding is supplied by the recipient via their Federal Financial Report). The recipient must be able to account separately for stewardship of the federal funding and for any required matching; it is subject to monitoring, oversight, and audit. The recipient may not use matching expenditures to count toward any Maintaining State Funding requirement.

When a recipient requests a carryover of unobligated funds from prior year(s), matching funds equal to the new requirement must be on record in the CDC grant file, or the recipient must provide evidence with the carryover request.

REPORTING REQUIREMENTS

DFC Progress Report:

In addition to the CDC Annual Performance/Progress Report (APR) which also serves as the non-competing continuation application, all DFC Recipients are required to submit a DFC Progress Report in August of the current calendar year (e.g. August 2024). The CDC program office will be in communication about the exact date. The report must be submitted through the DFC Me system (<https://dfcme.ondcp.eop.gov/>). For more information on the DFC Me system, please contact the DFC National Evaluation Team at dfc_evaluators@icf.com.

Core Measures Data

DFC recipients are required to provide core measures data every two years, via the DFC Me system, on the following core measures for alcohol, tobacco, marijuana, and (illicit) use of prescription drugs for three grades (6th-12th) with a recommended combination of at least one middle school grade and at least one high school grade:

1. Past 30-day use
2. Perception of risk or harm
3. Perception of parental disapproval of use
4. Perception of peer disapproval of use

Year 6 Recipients

Year 6 recipients who received continuous funding between Years 5 and 6 will remain on the core measure reporting schedule established in the first five years of DFC funding.

Year 6 recipients who have not had sequential years of DFC funding will need to speak with the DFC National Evaluation Team to determine when to report core measures. Please contact the DFC National Evaluation Team at dfc_evaluators@icf.com for more information.

PROGRAM OR FUNDING GENERAL REQUIREMENTS

Key Personnel Requirements: The following are updates to the DFC Key Personnel Requirements. All other terms and conditions issued with the original award remain in effect throughout the budget period unless otherwise changed, in writing, by the Grants Management Officer.

Authorized Organization Representative (AOR)

- The AOR must not be the same person as the project coordinator.

Program Director or Principal Investigator (PD/PI)

- The PI/PD is no longer required to be an employee of the recipient organization.

Award Expectations and Noncompliance: We can take corrective actions if your performance is poor. This means CDC may impose other enforcement actions in accordance with [45 CFR 75.371-Remedies for Noncompliance](#).

PAYMENT INFORMATION

Payment Management System Subaccount: Funds awarded in support of approved activities have been obligated in a subaccount in the PMS, herein identified as the “P Account”. Funds must be used in support of approved activities in the NOFO and the approved application.

The grant document number identified beginning on the bottom of Page 2 of the Notice of Award must be known in order to draw down funds.

Cover Page

**Michigan Department of Education
OFFICE OF EDUCATIONAL SUPPORTS
P.O. Box 30008
Lansing, MI 48909**

AUTHORITY: P.A. 103 of 2023.

Direct questions regarding this form to: Kellie Flaminio, MDE-
EarlyLiteracy@michigan.gov

COMPLETION: Required

2024 35j Professional Development, Curriculum and Supports Grant

Entity

Entity information below is maintained in the Education Entity Master (EEM). If corrections are needed please update EEM.

Entity Name **Agreement Number**

Hazel Park, School District of the City of - 63130 *63130*

Entity Address

1620 E ELZA AVE

City **Zip Code** **Entity County**

HAZEL PARK *480302358* *Oakland County*

Main Contact Person

Contact Name

Amy kruppe

Contact information listed below is maintained in MILogin. If corrections are needed please have user update their MILogin profile.

Telephone

224-629-6435

Email Address

amy.kruppe@myhpsd.org

Secondary Contact Person

Contact Name

Jason Zirmis

Contact information listed below is maintained in MILogin. If corrections are needed please have user update their MILogin profile.

Telephone Number

248-586-5217

Email Address

vector.zirnis@myhpsd.org

Assurances and Certifications

Save the Page to Proceed

Assurances and Certifications

ASSURANCES AND CERTIFICATIONS

— ASSURANCES FOR STATE AID GRANTS —

GRANT AWARD LIMITATIONS

State program grant allocations and awards are based on available legislative appropriations for specific grant programs. The state legislature has the prerogative to make changes in the state budget during the fiscal year. Final grant awards are contingent upon the MDE receiving sufficient state funding to award grants under the program. Not all projects will be fully funded when the total of applicant funding requests exceeds available state funds.

ASSURANCE REGARDING SANCTIONS AGAINST IRAN-LINKED BUSINESSES

The applicant assures that, for any request for proposals or contract renewal for work performed under this grant, it will collect a certification from each bidder that the bidder is not an Iran-Linked Business. An Iran-linked business is not eligible to submit a bid on a request for proposal with a public entity. Recipients must comply with all conditions under P.A. 517 of 2012, “Iran Economic Sanction Act,” April 1, 2013.

ASSURANCE CONCERNING MATERIALS DEVELOPED WITH FUNDS AWARDED UNDER THIS GRANT

The grantee assures that the following statement will be included on any publication or project materials developed with funds awarded under this program, including reports, films, brochures, and flyers: “These materials were developed under a grant awarded by the Michigan Department of Education.”

CERTIFICATION REGARDING NONDISCRIMINATION UNDER FEDERALLY AND STATE ASSISTED PROGRAMS

The applicant hereby agrees that it will comply with all Federal and Michigan laws and regulations prohibiting discrimination, and in accordance therewith, shall not discriminate against any person on the basis of religion, race, color, national origin or ancestry, age, sex, sexual orientation, gender identity or expression, height, weight, familial status, or marital status, exclude from participation in, deny the benefits of, or otherwise subject to discrimination in any program or activity for which it is responsible or for which it receives financial assistance from a U.S. Federal Agency or the Michigan Department of Education.

[Michigan Public Act 453 of 1976 (Elliott-Larsen Civil Rights Act), as amended by PA 6 of 2023]; [Title VI and Title VII of the Civil Rights Act of 1964 (45 U.S.C. 2000d through 2000d-4); Title IX of the Education Amendments of 1972 (20 U.S.C. 1681-1683); Age Discrimination Act of 1975 (42 U.S.C. 6101 et seq.)]

CERTIFICATION REGARDING TITLE II OF THE AMERICANS WITH DISABILITIES ACT (ADA), P.L. 101-336, STATE AND LOCAL GOVERNMENT SERVICES

The Americans with Disabilities Act (ADA) provides comprehensive civil rights protections for individuals with disabilities. Title II of the ADA covers programs, activities, and services of public entities. Title II requires that, "No qualified individual with a disability shall, by reason of such disability be excluded from participation in or be denied the benefits of the services, programs, or activities of a public entity, or be subjected to discrimination by such entity." In accordance with Title II ADA provisions, the applicant has conducted a review of its employment and program/service delivery processes and has developed solutions to correcting barriers identified in the review.

CERTIFICATION REGARDING TITLE III OF THE AMERICANS WITH DISABILITIES ACT (ADA), P.L. 101-336, PUBLIC ACCOMMODATIONS AND COMMERCIAL FACILITIES

The Americans with Disabilities Act (ADA) provides comprehensive civil rights protections for individuals with disabilities. Title III of the ADA covers public accommodations (private entities that affect commerce, such as museums, libraries, private schools and day care centers) and only addresses existing facilities and readily achievable barrier removal. In accordance with Title III provisions, the applicant has taken the necessary action to ensure that individuals with a disability are provided full and equal access to the goods, services, facilities, privileges, advantages, or accommodations offered by the applicant. In addition, a Title III entity, upon receiving a grant from the Michigan Department of Education, is required to meet the higher standards (i.e., program accessibility standards) as set forth in Title III of the ADA for the program or service for which they receive a grant.

ASSURANCE REGARDING COMPLIANCE WITH GRANT PROGRAM REQUIREMENTS

Grantee agrees to comply with all applicable requirements of all state statutes, federal laws, executive orders, regulations, policies, and award conditions governing this program. Grantee understands and agrees that if it materially fails to comply with the terms and conditions of the grant award, the Michigan Department of Education may withhold funds otherwise due to the grantee from this grant program, any other federal grant programs or the State School Aid Act of 1979 as amended, until the grantee comes into compliance or the matter has been adjudicated and the amount disallowed has been recaptured (forfeited). The Department may withhold up to 100 percent of any payment based on a monitoring finding, audit finding or pending final report.

Important Information

Save the Page to Proceed

Important Information

35j Important Information –

Budget Information - 3/27/24

To see the allocation and “Budget Summary” page you need to do the following:

- You will first need to click on “Modifications in Progress” at the bottom of the left-hand scrolling bar.
- Then you can move your application to “Apply Now” through the “Review Grant Selections.” At this point, you should be able to see the “Budget Summary” page.
- Once on the “Budget Summary” page, click the “Save” button in the top right to see your district’s allocation.
- Once you have added the budget items and made the necessary changes, then you can scroll down on the left-side scrolling bar to “Modifications Submitted” and select this button.
- MDE will then receive notification that your budget has been submitted for review.

Eligible LEAs will need to submit a budget for approval, aligned with the allocation and approved plan by April 5, 2024, to start receiving grant funds in the May state aid payment or May 3, 2024, to start receiving grant funds in the June state aid payment.

Please refer to the 35j FAQs for information regarding allowable use of funds. If you have any questions, email MDE-EarlyLiteracy@michigan.gov.

Overview

According to MCL 388.1635j, the purpose of the Professional Development, Curriculum, and Supports grant is to provide funds and support to districts and intermediate districts to improve literacy instructional practices by investing in quality, research-based best practices, and professional learning.

To be eligible for funds under 35j, districts must use the funding for all of the following purposes:

- Ensure 100% of Pre-K-5 educators, including administrators, coaches, and instructional coaches, complete selected professional learning training that is aligned to reading science.
- Complement existing efforts to improve literacy instruction.
- Develop and implement a comprehensive literacy system that is aligned to reading science.
- Use a valid screening tool, as determined by MDE, to identify gaps in current literacy practices and complete a needs assessment.
- Submit a plan to MDE targeting identified focus areas to address gaps in literacy practices.
- Report to MDE and post on its website which Pre-K to 5 literacy curriculum and benchmark assessment the district utilized.

There are two phases to the application process: districts must first be determined eligible. Once a list of eligible districts is compiled then allocations for each district will be determined. Eligible districts will then need to submit a budget for approval, aligned with the allocation and approved plan. Plans and budgets will be submitted through this NexSys grant platform. More information on the grant program can be found on the Professional Development, Curriculum, and Supports grant webpage (<https://www.michigan.gov/mde/services/academic-standards/literacy/section-35j>)

Application Instructions

Part 1 - Review Grant Selection

1. Find the “Review Grant Selections” page which is directly under this page on the left-hand scrolling bar.
2. Once within the page, select “Apply Later” and ensure to click the “Save” button in the top right corner. ***Do NOT select Apply Now until you have been told to do so by the department***

Part 2 – Uploading Targeted Literacy Plan into NexSys

1. Find the “Strategic 35j Plan” page within the Program Information Section.
2. After reading each of the eligibility assurances in their entirety, check off each of the boxes. Note: Checking off these boxes does not

preclude applicants from reading through the “Assurances and Certifications” page, as additional assurances are listed on this page.

3. *All boxes must be checked off on the “Strategic 35j Plan” page.*
4. *When uploading the targeted literacy plan through the Document Source subsection on the page, please ensure the document uses this naming convention – districtname_35jTargetedLiteracyPlan. This will help reviewers in tracking plans across districts.*
 1. *If you are an ISD applying on behalf of multiple districts, please use the “Add” button in the top left to give each district/PSA its own plan page.*
5. *Ensure to hit the save button (found in the top right portion of the page) after completing the page.*

If you have any questions regarding the 35j grant, please contact MDE-EarlyLiteracy@michigan.gov.

Part 3 – Initial Eligibility Determined & Next Steps

After initial eligibility has been determined by the department, districts will need to create and upload their budget in Nex.Sys for approval.

35j is a formula grant that will result in an equal amount per pupil based on the number of pupils in the district, or intermediate district in grades Pre-K to 5 based on 22-23 end of school year count. If every eligible district applies for funding, it will result in \$209.84 per pupil Pre-K to 5.

Amendment Justification

Amendment Justification

Provide a detailed description of the changes/updates made to this application.

updated second year plan.

Amendment Justification History

Amendment Justification History:

Review Grant Selections

35j Professional Development, Curriculum and Supports Grant

Do Not Apply

Apply Now

Apply Later

[X]

Budget Summary

Instructions:

- Budget Summary provides a compile of the budget items
- As appropriate, an individual program Budget Summary may display the following line(s): Allocations, Administrative Costs, Carryover, Indirect Costs
- If Indirect Costs are allowable, enter the amount in the textbox provided on this page
- Contact Information section: list individuals responsible for completing the budget section
- Completion of the Budget Summary is required for submission
- To add budget items, select the Budget Items page link in the side navigation menu
- The Budget Detail link provides a complete list of all individual budget items
- Some Program Offices may use the Flag Budget Item functionality to communicate allowability on specific budget items.
 - If Flag Budget Items are utilized, those pages are located in the budget section of the side navigation menu

Funding Source

35j Professional Development, Curriculum and Supports Grant

Agreement Number	Program Number	Project Number	CFDA Number	Starting Date	Ending Date	Fiscal Year
63130	24S740	232435	156523	10/01/2023	09/30/2025	2024 133

Function Codes	Salaries 1000	Benefits 2000	Purchased Services 3000, 4000	Supplies & Materials 5000	Capital Outlay 6000	Other Expenses 7000, 8000	Total
110 - Basic Programs	\$0	\$0	\$0	\$224,417	\$0	\$0	\$224,417
220 - Support Services - Instructional Staff	\$15,000	\$6,000	\$62,865	\$0	\$0	\$0	\$83,865
SUBTOTAL	\$15,000	\$6,000	\$62,865	\$224,417	\$0	\$0	\$308,282
TOTAL	\$15,000	\$6,000	\$62,865	\$224,417	\$0	\$0	\$308,282
Total Allocation Amount ,							\$308,282
Total Availability							\$308,282
Availability Balance							\$0

Contact Information

***Business Office Representative**

***Phone**

***Email**

Jason Zirnis

(249) 658-5200

jason.zirnis@myhpsd.org

***Project Contact Person**

***Phone**

***Email**

Amy Kruppe

(224) 629-6435

amy.kruppe@myhpsd.org

Budget Item

Instructions:

- To add a Budget Item complete all fields on the page (fields will vary based on Program requirements)
- Once all budget item fields have been completed, click **Save**
 - If errors exist, an error message will be displayed
- To add another Budget Item, click **Add** in the upper right-hand corner of the Budget Item screen
 - Repeat this process until all budget items are added
- To update an existing Budget Item, navigate to the budget item through the Budget Items pop-out menu (on the side navigation menu), select Budget Item, update as appropriate, and click **Save**
- To delete a Budget Item, navigate to the appropriate budget item and click **Delete** in the upper right-hand corner of the Budget Item screen

Funding Source

35j Professional Development, Curriculum and Supports Grant					
Program Number	Project Number	CFDA Number	Starting Date	Ending Date	Fiscal Year
		156523		09/30/2025	0

*Select the appropriate Function Code for this Budget Item:

111: Elementary

*Select the Priority Area with Strategy:

Develop and implement a comprehensive literacy system

*Funding Year:

Year 2

Provide a specific description for this budget item. Do not repeat the Function Code description selected in the drop down menu or the heading(s) of the box(es) used below:

Materials for 2024-2025 school year for K-5 ARC materials

Enter the dollar amount associated with the budget item. Enter an amount in only one box unless the item is Personnel. Personnel must have both Salaries and Benefits. To enter Capital Outlay, use the link for Capital Outlay.

Salaries	Benefits	Purchased Services	Supplies & Materials	Other Expenses	Total
(1000)	(2000)	(3000,4000)	(5000)	(7000,8000)	
\$	\$	\$	\$78,000	\$	\$78,000

If Salaries, enter the FTE or Hours

FTE **Hours**

Flag	Comment	Previous Total	Change +/-
Approved		\$78000	\$0

Budget Item

Instructions:

- To add a Budget Item complete all fields on the page (fields will vary based on Program requirements)
- Once all budget item fields have been completed, click **Save**
 - If errors exist, an error message will be displayed
- To add another Budget Item, click **Add** in the upper right-hand corner of the Budget Item screen
 - Repeat this process until all budget items are added
- To update an existing Budget Item, navigate to the budget item through the Budget Items pop-out menu (on the side navigation menu), select Budget Item, update as appropriate, and click **Save**
- To delete a Budget Item, navigate to the appropriate budget item and click **Delete** in the upper right-hand corner of the Budget Item screen

Funding Source

35j Professional Development, Curriculum and Supports Grant					
Program Number	Project Number	CFDA Number	Starting Date	Ending Date	Fiscal Year
24S740	232435	156523	10/01/2023	09/30/2025	2024

*Select the appropriate Function Code for this Budget Item:

111: Elementary

*Select the Priority Area with Strategy:

Develop and implement a comprehensive literacy system

*Funding Year:

Year 1

Provide a specific description for this budget item. Do not repeat the Function Code description selected in the drop down menu or the heading(s) of the box(es) used below:

Materials to support science of reading support program. K-5. Change: ARC materials to support science of reading. This includes texts and instruction materials. Progress is assess through ARC Urla and I-ready

Enter the dollar amount associated with the budget item. Enter an amount in only one box unless the item is Personnel. Personnel must have both Salaries and Benefits. To enter Capital Outlay, use the link for Capital Outlay.

Salaries	Benefits	Purchased Services	Supplies & Materials	Other Expenses	Total
(1000)	(2000)	(3000,4000)	(5000)	(7000,8000)	
\$	\$	\$	\$88,572	\$	\$88,572

If Salaries, enter the FTE or Hours

FTE Hours

Flag	Comment	Previous Total	Change +/-
Approved		\$88572	\$0

Budget Item

Instructions:

- To add a Budget Item complete all fields on the page (fields will vary based on Program requirements)
- Once all budget item fields have been completed, click **Save**
 - If errors exist, an error message will be displayed
- To add another Budget Item, click **Add** in the upper right-hand corner of the Budget Item screen
 - Repeat this process until all budget items are added
- To update an existing Budget Item, navigate to the budget item through the Budget Items pop-out menu (on the side navigation menu), select Budget Item, update as appropriate, and click **Save**
- To delete a Budget Item, navigate to the appropriate budget item and click **Delete** in the upper right-hand corner of the Budget Item screen

Funding Source

35j Professional Development, Curriculum and Supports Grant					
Program Number	Project Number	CFDA Number	Starting Date	Ending Date	Fiscal Year
24S740	232435	156523	10/01/2023	09/30/2025	2024

*Select the appropriate Function Code for this Budget Item:

118: Pre-Kindergarten

*Select the Priority Area with Strategy:

Develop and implement a comprehensive literacy system

*Funding Year:

Year 1

Provide a specific description for this budget item. Do not repeat the Function Code description selected in the drop down menu or the heading(s) of the box(es) used below:

Material strategies and essentials for EC. from science of reading ARC program. Students are assessed with materials from Creative Curriculum .

Enter the dollar amount associated with the budget item. Enter an amount in only one box unless the item is Personnel. Personnel must have both Salaries and Benefits. To enter Capital Outlay, use the link for Capital Outlay.

Salaries	Benefits	Purchased Services	Supplies & Materials	Other Expenses	Total
(1000)	(2000)	(3000,4000)	(5000)	(7000,8000)	
\$	\$	\$	\$57,845	\$	\$57,845

If Salaries, enter the FTE or Hours

FTE **Hours**

Flag	Comment	Previous Total	Change +/-
Approved		\$57845	\$0

Budget Item

Instructions:

- To add a Budget Item complete all fields on the page (fields will vary based on Program requirements)
- Once all budget item fields have been completed, click **Save**
 - If errors exist, an error message will be displayed
- To add another Budget Item, click **Add** in the upper right-hand corner of the Budget Item screen
 - Repeat this process until all budget items are added
- To update an existing Budget Item, navigate to the budget item through the Budget Items pop-out menu (on the side navigation menu), select Budget Item, update as appropriate, and click **Save**
- To delete a Budget Item, navigate to the appropriate budget item and click **Delete** in the upper right-hand corner of the Budget Item screen

Funding Source

35j Professional Development, Curriculum and Supports Grant					
Program Number	Project Number	CFDA Number	Starting Date	Ending Date	Fiscal Year
		156523		09/30/2025	0

*Select the appropriate Function Code for this Budget Item:

221: Improvement of Instruction

*Select the Priority Area with Strategy:

Professional Learning

*Funding Year:

Year 2

Provide a specific description for this budget item. Do not repeat the Function Code description selected in the drop down menu or the heading(s) of the box(es) used below:

stipends for staff members that complete LETRS training . \$1000 for 15 staff members.

Enter the dollar amount associated with the budget item. Enter an amount in only one box unless the item is Personnel. Personnel must have both Salaries and Benefits. To enter Capital Outlay, use the link for Capital Outlay.

Salaries (1000)	Benefits (2000)	Purchased Services (3000,4000)	Supplies & Materials (5000)	Other Expenses (7000,8000)	Total
\$15,000	\$6,000	\$	\$	\$	\$21,000

If Salaries, enter the FTE or Hours

FTE	Hours
	600.00

Flag	Comment	Previous Total	Change +/-
Approved		\$21000	\$0

Budget Item

Instructions:

- To add a Budget Item complete all fields on the page (fields will vary based on Program requirements)
- Once all budget item fields have been completed, click **Save**
 - If errors exist, an error message will be displayed
- To add another Budget Item, click **Add** in the upper right-hand corner of the Budget Item screen
 - Repeat this process until all budget items are added
- To update an existing Budget Item, navigate to the budget item through the Budget Items pop-out menu (on the side navigation menu), select Budget Item, update as appropriate, and click **Save**
- To delete a Budget Item, navigate to the appropriate budget item and click **Delete** in the upper right-hand corner of the Budget Item screen

Funding Source

35j Professional Development, Curriculum and Supports Grant					
Program Number	Project Number	CFDA Number	Starting Date	Ending Date	Fiscal Year
		156523		09/30/2025	0

*Select the appropriate Function Code for this Budget Item:

221: Improvement of Instruction

*Select the Priority Area with Strategy:

Professional Learning

*Funding Year:

Year 2

Provide a specific description for this budget item. Do not repeat the Function Code description selected in the drop down menu or the heading(s) of the box(es) used below:

Professional coaching for the K-5 staff for ARC .

Enter the dollar amount associated with the budget item. Enter an amount in only one box unless the item is Personnel. Personnel must have both Salaries and Benefits. To enter Capital Outlay, use the link for Capital Outlay.

Salaries	Benefits	Purchased Services	Supplies & Materials	Other Expenses	Total
(1000)	(2000)	(3000,4000)	(5000)	(7000,8000)	
\$	\$	\$62,865	\$	\$	\$62,865

If Salaries, enter the FTE or Hours

FTE **Hours**

Flag	Comment	Previous Total	Change +/-
Approved		\$62865	\$0

Flagged Budget Items

Instructions:

- Flagged Budget Items displays the budget items in detail
- If Flagged Budget Item has been used by the Program Office Reviewer, a flag for allowability of the individual budget item will be displayed in the flag field along with any comments
- Budget Item detail can be accessed by clicking the function code link
- Availability to update flagged budget items is dependent on the flag for the individual budget item and application status:
 - Modifications Required:
 - Recipients must first change the application status to a Modifications in Progress Status
 - Unallowable budget items must be deleted from the budget section
 - Modifications required budget items must be updated appropriately based on comments provided by the Reviewer
 - Approved budget items are locked and will not allow edits
 - Amendment In Progress:
 - All budget items are available to update as allowable by program guidelines

Flagged Budget Items

Entity

Hazel Park, School District of the City of - 63130

140

Flag	Comment	Function Code	Description	Salaries	Benefits	Purchased Services	Supplies & Materials	Capital Outlay	Other	Total
Approved		111: Elementary	Materials to support science of reading support program. K-5. Change: ARC materials to support science of reading. This includes texts and instruction materials. Progress is assess through ARC Urla and I-ready	\$0	\$0	\$0	\$88572	\$0	\$0	\$88572
Approved		111: Elementary	Materials for 2024-2025 school year for K-5 ARC materials	\$0	\$0	\$0	\$78000	\$0	\$0	\$78000

<i>Approved</i>	<u>118: Pre-Kindergarten</u>	<i>Material strategies and essentials for EC. from science of reading ARC program. Students are assessed with materials from Creative Curriculum .</i>	\$0	\$0	\$0	\$57845	\$0	\$0	\$57845
<i>Approved</i>	<u>221: Improvement of Instruction</u>	<i>stipends for staff members that complete LETRS training . \$1000 for 15 staff members.</i>	\$15000	\$6000	\$0	\$0	\$0	\$0	\$21000
<i>Approved</i>	<u>221: Improvement of Instruction</u>	<i>Professional coaching for the K-5 staff for ARC .</i>	\$0	\$0	\$62865	\$0	\$0	\$0	\$62865

Total \$308282

Approved Total \$308282

Modifications Required Total \$

Unallowable Total \$ 141

Strategic 35j Plan

Instructions:

1. Type a descriptive title for the document that will be uploaded.
2. Click the **Select** button and search for the document.
3. Once selected, the path to the file will appear in the Document Source field.
4. Click the **Save** button.
5. To upload another document, click the **Add** button.

NOTE: When the file is named to be uploaded, **DO NOT** leave any spaces, place a period between the words OR use any special characters, e.g. "/", in the document name. Attachments may be in **Word, PDF, JPG, XLS or GIF** format. The maximum file upload size is 15MB per files uploaded on each page. The descriptive title entered does not have to be the same as the file name, and it can include spaces.

Strategic 35j Plan

By checking off each box, you understand that the specific steps are required followed by each of these assurances with a checkbox.

[X]

Ensure 100% of Pre-K-5 educators including administrators, coaches, and instructional coaches complete the selected professional learning training.

The selected professional learning must be aligned to reading science (also referred to as the science of reading) and include all the following literacy best practices:

- **Language comprehension** (Background knowledge; Explicit vocabulary instruction; Language Structures; Verbal reasoning; Literacy knowledge)
- **Word recognition** (Phonological awareness; Decoding; Sight; Recognition of familiar words; Encoding)
- **Abundant reading materials** (Diverse classroom libraries; Relevant text; High interest topics)
- Supports educators in understanding how literacy best practices should be represented and organized in class-wide reading curriculum resources to provide daily instruction to students in all the skills and processes needed for reading at or above grade level expectations.
- Provides instructional routines, resources for enhancing literacy curriculum resources to strengthen instruction in literacy best practices.
- Supports educators in understanding the types of assessment practices needed to identify students with reading difficulties and for monitoring their progress in reading intervention instruction.
- Be offered using a professional development platform that includes the following:
 - Allows educators synchronous (live learning with a trainer of record) and asynchronous (learning on the participant's own schedule and timeline accessing readings and an online learning platform)
 - Provides participants pre and post assessment data to understand the knowledge gained having participated in the learning.
 - Allows districts to monitor 100% participant completion

[X]

Complement existing efforts to improve literacy instruction.

[X]

Develop and implement a comprehensive literacy system.

[X]

Literacy curriculum eligible for funding must be aligned to reading science.

[X]

Use a valid screening tool, as determined by MDE, to identify gaps in current literacy practices and complete a needs assessment (required component to be eligible for year 2 funding).

[X]

The district or intermediate district must post to their website their pre-K to grade 5 literacy curriculum and benchmark assessments and share the link to MDE (required component to be eligible for year 2 funding).

[X]

Submit a plan to MDE targeting identified focus areas to address gaps in literacy practices.

Name of the selected professional learning training that meets the criteria outlined in the assurances:

Hazel Park Schools is using the American reading company. coaches work with all staff.

Name of the Pre-K to 5 curriculum:

Pre-K

American Reading Company

K

American Reading Company

1

American Reading Company

2

American Reading Company

3

American Reading Company

4

American Reading Company

5

American Reading company

Upload your district's or intermediate district's literacy plan to target identified focus areas to address gaps in literacy practices

***Title**

ARC Core literacy

***Document Source**

Literacy Plan, Professional Learning, and Approved Assessment.pdf

Year 2 Amendments

Instructions: To be approved for year two funding, previously approved districts must complete a phase two application which includes:

- Documentation ensuring 100% of current pre-K to grade 5 teachers are registered for and/or are on target to complete the selected professional learning.
- The link to the district or intermediate district's website where the pre-K to grade 5 literacy curriculum and benchmark assessments are posted.

1. Type a descriptive title for the document that will be uploaded.
2. Click the **Select** button and search for the document.
3. Once selected, the path to the file will appear in the Document Source field.
4. Click the **Save** button.
5. To upload another document, click the **Add** button.

NOTE: When the file is named to be uploaded, **DO NOT** leave any spaces, place a period between the words OR use any special characters, e.g. "/", in the document name. Attachments may be in **Word, PDF, JPG, XLS or GIF** format. The maximum file upload size is 15MB per files uploaded on each page. The descriptive title entered does not have to be the same as the file name, and it can include spaces.

Year 2 Amendments

Title

Professional Develop for K-5 teachers

Document Source

35j Evidence - K-5 Literacy-Based Professional Development, Core Curriculum, and Benchmark Assessments.pdf

Attachments

Instructions:

1. Type a descriptive title for the document that will be uploaded.
2. Click the **Select** button and search for the document.
3. Once selected, the path to the file will appear in the Document Source field.
4. Click the **Save** button.
5. To upload another document, click the **Add** button.

NOTE: When the file is named to be uploaded, **DO NOT** leave any spaces, place a period between the words OR use any special characters, e.g. "/", in the document name. Attachments may be in **Word, PDF, JPG, XLS or GIF** format. The maximum file upload size is 15MB per files uploaded on each page. The descriptive title entered does not have to be the same as the file name, and it can include spaces.

Attachments**Title**

MICIP Reading Goals and CNA - 2023-24

Document Source

MICIP - K-8 2023-2024 Plan.pdf

State of Michigan Attachments

Instructions:

1. Type a descriptive title for the document that will be uploaded.
2. Click the **Select** button and search for the document.
3. Once selected, the path to the file will appear in the Document Source field.
4. Click the **Save** button.
5. To upload another document, click the **Add** button.

NOTE: When the file is named to be uploaded, **DO NOT** leave any spaces, place a period between the words OR use any special characters, e.g. "/", in the document name. Attachments may be in **Word, PDF, JPG, XLS or GIF** format. The maximum file upload size is 15MB per files uploaded on each page. The descriptive title entered does not have to be the same as the file name, and it can include spaces.

State of Michigan Attachments**Title**

35j Budget Review

Document Source

Hazel Park, School District of the City of 63130 - Eligibility Review.pdf



Ford Administration
1620 E. Elza, Hazel Park, MI 48030 | 248-658-5200 | F: 248-544-5223
www.hazelparkschools.org

To: Dr. Amy Kruppe, Superintendent
From: Dr. Stephanie Dulmage, Assistant Superintendent of Teaching and Learning
Subject: 23H Improvement of Mathematics Teaching and Learning - Grant Award
Date: November 18, 2024

23h Improvement of Mathematics Teaching and Learning Grant

Section 23h of the 2023-2024 School Aid Bill provided \$25,000,000 to support mathematics teaching and learning. This past Spring, Oakland Schools invited districts to participate in a multi-ISD consortium application with KRESA, MISTEM, and Oakland Schools. The application focused on the expansion of math recovery specialists statewide through intermediate school districts. Fortunately, the application was approved, allowing Hazel Park to provide Math Recovery Training for up to 14 teachers and 1 Math Recovery Specialist.

Math Recovery's Add+VantageMR® (AVMR) 1 training focuses on foundational numeracy skills, particularly in number sense and early arithmetic strategies, for students in grades K-5. The training equips educators with tools to assess and support students' understanding of number concepts, counting principles, and early addition and subtraction. Key components include:

- Diagnostic Assessment Tools
- Instructional Strategies
- Individualized Interventions
- Data-Driven Instruction

Math Recovery specialist training includes advanced training in AVMR1 and AVMR2 (place value, multi-digit addition and subtraction, and multiplication and division strategies). This training positions the math recovery specialist to provide more targeted support to students and coaching/collaboration with other math recovery training staff members.

Since the award went to the ISDs, Hazel Park School District does not receive direct grant funds. As noted, Hazel Park received 14 seats for AVMR-related courses and 1 seat for MRSp1 (Specialist). The value for these seats and other supports is listed below:

- 14 AVMR1 & 2 seats @ 434.50 + additional materials & lunch total benefit total - $\$520 \times 14 = \$7,280$
- 1 Specialist seat @ 1,800 + additional materials & lunch total benefit total - $\$2,100 \times 1 = \$2,100$
 - Total benefit for AVMR + Specialist courses = \$9,380 through 23h grant
- *If Hazel Park needed to pay the US Math Recovery Council directly to enroll in these courses the total cost would be:*





**HAZEL PARK
SCHOOLS**

- *AVMR 14 x \$995 = \$13,930*
- *Specialist 1 x \$6,000 = \$6,000*
- *Total benefit at USMRC cost = \$19,930*

Additional benefits include relationship building across the district through the AVMR course taking place in Hazel Park, and within the county (instead of remotely through USMRC), and follow-up support from an ISD consultant. through me and other Oakland Schools consultants. The convenience and consistency gained from the ISD support, contribute to lasting partnerships and ongoing development opportunities within the county.

Strategic Plan Alignment

Funding Source: Not Applicable

Strategic Goal Alignment:

- Curriculum & Instruction: Hazel Park Schools will develop innovative, independent, and persistent learners who think critically, communicate effectively, and positively influence the local and global community.
- Climate and Culture: The Hazel Park School District will provide a unified system of support for all students, embracing diversity, and fostering a positive school climate.