



Ford Administration
1620 E. Elza, Hazel Park, MI 48030 | 248-658-5200 | F: 248-544-5223
www.hazelparkschools.org

Agenda

Regular Meeting

Ford Administration Building

1620 E Elza Avenue

Hazel Park, MI 48030

December 12, 2022

7:00 PM

LOCATION AND FORMAT: The meeting will be held at the Ford Administration Building, 1620 E Elza Hazel Park, Michigan. It will be live-streamed on YouTube. Members of the public wishing to speak during the public comment portion of the meeting may do so in-person or by emailing Board President, Laura Adkins, prior to the meeting at laura.adkins@hazelparkschools.org.

CALL TO ORDER

ROLL CALL

PLEDGE OF ALLEGIANCE

APPROVAL OF THE AGENDA (ACTION ITEM)

PUBLIC COMMENT

The Board of Education recognizes the value of public comment on education items and the importance of allowing members of the public to express themselves on District matters.

During this portion of public comment, each statement made by a participant shall be limited to three (3) minutes and participants must identify themselves by name and address.

SPECIAL ORDER OF BUSINESS

- A. Marching Band
- B. Advanced Placement Recognition
- C. United Oaks Presentation
- D. Volleyball Team
- E. Advantage Representative
- F. Junior High Representatives
- G. High School Representatives
- H. MI HEART Presentation

CONSENT AGENDA (Action Items)

The Board of Education shall use a consent agenda to keep routine matters within a reasonable time frame. A member of the Board may request any item to be removed from the consent agenda and defer it for more discussion and specific action.

A. <u>Approval of Minutes</u>	
1) Board Meetings	3
2) Committee Meetings	
B. <u>Monthly Financial Reports</u>	12
C. <u>Personnel Recommendations</u>	23
D. <u>Conference Requests</u>	24

NEW BUSINESS

A. Budget Amendment #1 (Action Item)	25
B. Food Service/Sinking Fund Project for BID (Action Item)	30
C. Natatorium Cost & Approval (Action Item)	41
D. Masonry Approval (Action Item)	93
E. PBIS Data (Informational)	94
F. School of Choice Resolution (Action Item)	117
G. Freedom Of Information Act (Informational)	

SUPERINTENDENT REPORT

A. Attendance	118
B. Fundraisers	120
C. Discipline Presentation	121
D. Administrative Coaching	129

REQUESTS FOR FUTURE AGENDA ITEMS

CALENDAR DATES

PUBLIC COMMENT

During this portion of public comment, each statement made by a participant shall be limited to one (1) minute and participants must identify themselves by name and address.

BOARD MEMBER AND ADMINISTRATION COMMENTS

ADJOURNMENT

Any person with a disability who needs accommodation for participation in this meeting should contact the Superintendent's office at (248) 658-5220 at least five (5) days in advance of the meeting to request assistance.

All Official minutes of school board meetings are stored and available for inspection in the Ford Administration office at the above address.

This notice is given in compliance with Act No. 267 of the Public Acts Michigan, 1976



SCHOOL DISTRICT OF THE
CITY OF HAZEL PARK
COUNTY OF OAKLAND AND STATE OF MI
REGULAR MEETING
November 14, 2022 7:00 PM

CALL TO ORDER

The Regular Meeting of the Hazel Park Board of Education was held on November 14, 2022 and was called to order by President Adkins at 7:00 p.m.

ROLL CALL

Members Present: Adkins, Baldwin, Fortress, Nagy, Noth, Rice
Members Absent: Hinton
Others Present: Kruppe, Zirniss, Dulmage, Wilkins

PLEDGE OF ALLEGIANCE

APPROVAL OF THE AGENDA (ACTION ITEM)

Moved by Fortress, supported by Noth, that the Board of Education approve the agenda as written, with the removal of item E, the Pool Update.

Discussion

Roll Call Vote

Yeas: Fortress, Noth, Baldwin, Nagy, Rice, Adkins

Nays:

Motion carried.

PUBLIC COMMENT - None

SPECIAL ORDER OF BUSINESS

A. Webb Elementary Presentation

Mrs. Nastasi and three fifth grade students presented to the Board of Education regarding their October theme of Anti-Bullying with a focus on Kindness. They had many events and fun activities to learn these valuable lessons on how to recognize it, what it means and what to do if you see it. Mrs Nastasi also started each morning with tips to help the students handle these difficult situations.

B. Junior High Representatives

Thomas Barkle and Madison Rattee presented information on what was happening at the Junior High. Thomas spoke of some things that had been improved upon since last month when he voiced some new concerns, such as the drinking fountains not working properly. Madison spoke of the great events happening

like the Washington DC trip. She also shared some other areas she would like to see improve such as more clubs, dances, and activities for the students to participate in. She also requested to get foreign language classes and National Junior Honor Society brought to the Junior High.

C. High School Representatives

Sarah Griffiths and Jenna Durbrow spoke of events that took place at the high school. They spoke about the Band and their accomplishments, as well as the volleyball team. Sarah shared that one of the National Honor Society students will be receiving a \$2000 scholarship. Jenna spoke about the pool and the excitement the students have for the opening. She talked about girls wrestling and clubs that have more members than previous years.

D. Advantage Representatives

Jariyah Collins presented the exciting things happening at Advantage. She talked about spirit week and the fun the students had participating in it. The Basketball team won 2nd place in their tournament but she also spoke of some concerns on the labels that get placed on students of this alternative program and continued to explain that some just learn better in a smaller style setting. She stated she would like to see a better library for the students as well as other suggestions.

CONSENT AGENDA (Action Items)

- A. Approval of Minutes
 - 1. Board Meetings
- B. Monthly Financial Reports
- C. Personnel Recommendations
- D. Conference Requests

Moved by Noth, supported by Baldwin, that the Board of Education approve the consent agenda, as presented.

Discussion

Roll Call Vote

Yeas: Noth, Baldwin, Fortress, Nagy, Rice, Adkins

Nays:

Abstain:

Motion carried.

NEW BUSINESS

- A. Audit Presentation and Approval (Action Item)

Moved by Noth, supported by Rice, that the Board of Education approve the Audit Presentation.

Discussion

Roll Call Vote

Yeas: Noth, Rice, Baldwin, Fortress, Nagy, Adkins

Nays:

Abstain:

Motion carried.

November 14, 2022

B. IPM (Action Item)

Moved by Noth, supported by Rice, that the Board of Education approve the Integrated Pest Management, as presented.

Discussion

Roll Call Vote

Yeas: Noth, Rice, Baldwin, Fortress, Nagy, Adkins

Nays:

Abstain:

Motion carried.

C. Review Sinking Fund Plan (Informational Item)

D. Vehicle Change Approval (Action Item)

Moved by Fortress, supported by Baldwin, that the Board of Education approve the purchase of the Salt Dogg and the V-Plow with the residual funds from the truck approved purchase.

Discussion

Roll Call Vote

Yeas: Fortress, Baldwin, Nagy, Noth, Rice, Adkins

Nays:

Abstain:

Motion carried.

~~E. Pool Update~~

F. American Reading Company (Action Item)

Moved by Noth, supported by Fortress., that the Board of Education approve the purchase of materials to support the continued implementation of ARC Core in an amount not to exceed 85,000.

Discussion

Roll Call Vote

Yeas: Noth, Fortress, Baldwin, Nagy, Rice, Adkins

Nays:

Abstain:

Motion carried.

G. Additional Latchkey Paraprofessional (Action Item)

Moved by Fortress, supported by Nagy, that the Board of Education approve a third latchkey paraprofessional for the 2022-2023 school year at Hoover Elementary, as presented.

Discussion

Roll Call Vote

Yeas: Fortress, Nagy, Baldwin, Rice, Adkins

Nays:

Abstain: Noth (familial conflict)

Motion carried.

H. LEO Quarterly Written Report (Informational Item)

November 14, 2022

I. District Radios (Action Item)

Moved by Noth, supported by Rice, that the Board of Education approve the purchase of additional district radios to address safety concerns as we continue to improve upon safety at all our schools in the district.

Discussion

Roll Call Vote

Yeas: Noth, Rice, Baldwin, Fortress, Nagy, Adkins

Nays:

Abstain:

Motion carried.

J. Letter of Agreement - Incorrect Payout (Action Item)

Moved by Fortress, supported by Nagy, that the Board of Education approve the Incorrect Payout, as presented.

Discussion

Roll Call Vote

Yeas: Fortress, Nagy, Baldwin, Noth, Rice, Adkins

Nays:

Abstain:

Motion carried.

K. Letter of Agreement - Nancy Stevens Planning Periods (Action Item)

Moved by Baldwin, supported by Noth, that the Board of Education approve the Nancy Stevens Planning Periods, as presented.

Discussion

Roll Call Vote

Yeas: Baldwin, Noth, Fortress, Nagy, Rice, Adkins

Nays:

Abstain:

Motion carried.

L. Letter of Agreement - Payment of Days to HPEA Sick Bank (Action Item)

Moved by Baldwin, supported by Noth, that the Board of Education approve the Payment of Days to HPEA Sick Bank, as presented.

Discussion

Roll Call Vote

Yeas: Baldwin, Noth, Fortress, Nagy, Rice, Adkins

Nays:

Abstain:

Motion carried.

M. Letter of Agreement - Summer Program 2022, 2023 & 2024 (Action Item)

Moved by Baldwin, supported by Noth, that the Board of Education approve the Summer Program 2022, 2023 & 2024, as presented.

November 14, 2022

Discussion

Roll Call Vote

Yeas: Baldwin, Noth, Fortress, Nagy, Rice, Adkins

Nays:

Abstain:

Motion carried.

N. Letter of Agreement - Teacher Choice Professional Development (Action Item)

Moved by Baldwin, supported by Noth, that the Board of Education approve the Teacher Choice Professional Development, as presented.

Discussion

Roll Call Vote

Yeas: Baldwin, Noth, Fortress, Nagy, Rice, Adkins

Nays:

Abstain:

Motion carried.

O. Letter of Agreement - United Oaks Grant Funds (Action Item)

Moved by Baldwin, supported by Rice, that the Board of Education approve the United Oaks Grant Funds, as presented.

Discussion

Roll Call Vote

Yeas: Baldwin, Rice, Fortress, Nagy, Noth, Adkins

Nays:

Abstain:

Motion carried/failed

P. Letter of Agreement - Welcome Back Proud Michigan Educator (Action Item)

Moved by Baldwin, supported by Nagy, that the Board of Education approve the Welcome Back Proud Michigan Educator, as presented.

Discussion

Roll Call Vote

Yeas: Baldwin, Nagy, Fortress, Noth, Rice, Adkins

Nays:

Abstain:

Motion carried.

Q. Letter of Agreement - Healthy Communities Coalition Grant 2022-23 (Action Item)

Moved by Baldwin, supported by Nagy, that the Board of Education approve the Healthy Communities Coalition Grant 2022-23, as presented.

November 14, 2022

Discussion

Roll Call Vote

Yeas: Baldwin, Fortress, Nagy, Noth, Rice, Adkins

Nays:

Abstain:

Motion carried.

R. Letter of Agreement - Covid Leave 2022 (Action Item)

Moved by Nagy, supported by Baldwin, that the Board of Education approve the LOA for Covid Leave 2022, as presented.

Discussion

Roll Call Vote

Yeas: Nagy, Baldwin, Fortress, Nagy, Noth, Rice, Adkins

Nays:

Abstain:

Motion carried.

S. Letter of Agreement - Christopher Benedetto Retroactive Pay (Action Item)

Moved by Nagy, supported by Baldwin, that the Board of Education approve the LOA for Christopher Benedetto's Retroactive Pay, as presented.

Discussion

Roll Call Vote

Yeas: Nagy, Baldwin, Fortress, Nagy, Noth, Rice, Adkins

Nays:

Abstain:

Motion carried.

T. Letter of Agreement - Uncertified Bargaining Unit Members (Action Item)

Moved by Baldwin, supported by Nagy, that the Board of Education approve the LOA for Uncertified Bargaining Unit Members, as presented.

Discussion

Roll Call Vote

Yeas: Baldwin, Nagy, Fortress, Noth, Rice, Adkins

Nays:

Abstain:

Motion carried.

U. Letter of Agreement - Mitchell Dance Grievance (Action Item)

Moved by Noth, supported by Rice, that the Board of Education approve the LOA for Mitchell Dance Grievance, as presented.

Discussion

Roll Call Vote

Yeas: Noth, Rice, Baldwin, Fortress, Nagy, Adkins

Nays:

Abstain:

Motion carried.

V. Letter of Agreement - Ancillary Staff Outside Experience Credit (Action Item)

Moved by Noth, supported by Baldwin, that the Board of Education approve the LOA for Uncertified Bargaining Unit Members, as presented.

Discussion

Roll Call Vote

Yeas: Noth, Baldwin, Fortress, Nagy, Rice, Adkins

Nays:

Abstain:

Motion carried.

SUPERINTENDENT REPORT

A. MSBO Business Manager Academy (Informational Item)

Dr Kruppe shared with the Board of Education that Mr. Imran Mirza has completed his MSBO Business Office

B. School Board Training (Informational Item)

Dr Kruppe made suggestions on different sessions for School Board Training with the new Board Members

C. Attendance (Informational Item)

REQUESTS FOR FUTURE AGENDA ITEMS

CALENDAR DATES

PUBLIC COMMENT

BOARD MEMBER AND ADMINISTRATION COMMENTS

Rick Nagy, Trustee -

Congrats to the new Board members and Bev. Thank you everyone for being here and have a great Thanksgiving everyone!

Melissa Baldwin, Board Vice President -

Thanks to all the students who came out. To the high school who spoke on a sensitive issue, I commend you because that is not easy. Congrats to Debbie, Monica and Bev. Band and Volleyball did great, its so exciting to see. Happy Thanksgiving everyone! Oh, and the play was great! If you can come out and support the next one.

Dawn Rice, Board Trustee -

Thank you, I appreciate everyone! Happy Thanksgiving!

Rachel Noth, Board Trustee -

Great feedback! I am so pleased we are following policies. Just some reminders, the Tree Lighting is next Tuesday and the Choir and Band will be attending. Congratulations to Debbie, Monica and Bev. I just hope now that the election is over, everyone can keep the kiddos at heart. Happy Thanksgiving everyone!

Heidi Fortress, Board Treasurer -

It was great to hear about the scholarship, I hope we can bring her to a meeting to recognize that. I would love to sponsor a couple kids for some of the NHS events. Happy Thanksgiving!

Dr. Amy Kruppe, Superintendent -

The Tree Lighting begins at 6pm and we will be doing a Boot & Shoe Drive. Donations can be brought here to Ford, to the Library and also to the Tree Lighting. Community Engagement will have crafts for the kids to make during the event. Also, Ferndale opened up a story walk at Martin Road Park. I was invited to participate and it was a great event as we work towards strengthening our relationship with the city of Ferndale.

Laura Adkins, Board President -

Yes, Community Engagement will be at the Tree Lighting. We will also be doing a Resource Fair, and the Senior Concert. Its always so great having the kids here! Congratulations to Debbie, Monica and Bev. I appreciate the update on training, there are a lot of great activities. I'm hoping the auditorium proposal will be coming soon and I suggest the new board really considers working on their social media policy in the coming year. Happy Thanksgiving everyone!

ADJOURNMENT

Moved and supported that the meeting be adjourned at 8:42 pm
Unanimous Approval.

Respectfully Submitted,

Beverly Hinton, Secretary
Hazel Park Board of Education



SCHOOL DISTRICT OF THE
CITY OF HAZEL PARK
COUNTY OF OAKLAND AND STATE OF MICHIGAN
SPECIAL MEETING

CALL TO ORDER

The Special Meeting of the Hazel Park Board of Education was held on December 5, 2022 and was called to order by President Adkins at 6:34 PM.

ROLL CALL

Members Present: Adkins, Baldwin, Hinton, Nagy, Noth

Members Absent: Fortress, Rice

Others Present: Kruppe

APPROVAL OF THE AGENDA (Action Item)

Moved by Baldwin, supported by Hinton, that the Board of Education approve the agenda as written.

Discussion

Roll Call Vote

Yeas Baldwin, Hinton, Nagy, Noth, Adkins

Nays:

Motion carried.

PUBLIC COMMENT - None

BOARD ROUND TABLE

CLOSED SESSION

- A. Motion to recess into closed session for Superintendent evaluation pursuant to Section 8(a) of the Open Meetings Act.

Moved by Baldwin, supported by Hinton, to recess into closed session for Superintendent evaluation pursuant to Section 8(a) of the Open Meetings Act.

Discussion

Roll Call Vote:

Yeas: Baldwin, Hinton, Nagy, Noth, Adkins

Nays:

Motion carried.

President Adkins called the meeting back to order at 7:39pm.

Board Members and Administration Comments

Moved and supported that the meeting be adjourned at 7:51 p.m.

Unanimous Approval.

Respectfully Submitted,

Beverly Hinton, Secretary
Hazel Park Board of Education



Ford Administration
Matthew Miller, Business Office Manager
1620 E. Elza, Hazel Park, MI 48030 | 248-658-5213 | F: 248-544-5443
www.hazelparkschools.org

TO: The School District of the City of Hazel Park
Board of Education

FROM: Jason Zirmis
Assistant Superintendent, Business & Operations

RE: Treasurer's Report October, 2022

DATE: December 8, 2022

Attached is the check register (including current period voids), a listing of ACH debits, wire transfers, and P-Card purchases made during the period

GENERAL FUND (11)		2,056,718.51	
	<i>Total - General Fund</i>	<u>\$ 2,056,718.51</u>	
CENTER PROGRAM (22)		25,188.21	
COMMUNITY SERVICE (23)		652.23	
FOOD SERVICE FUND (25)		197,368.81	
COMMON DEBT (31-39)		0.00	
CAPITAL PROJECTS (41-49)		214,995.72	
	<i>Total - Special Revenue Funds</i>	<u>\$ 438,204.97</u>	
INTERNAL ACCOUNT FUNDS (29)		1,684.99	
	<i>Total - Other Funds</i>	<u>\$ 1,684.99</u>	
TOTAL CHECK DISBURSEMENTS		<u><u>\$ 2,496,608.47</u></u>	\$ 2,496,608.47
ACH DEBITS			1,360,488.55
PAYROLL			1,349,488.71
OUTGOING WIRE TRANSFERS			2,640,217.60
P-CARD PURCHASES			174,366.64
			<u>5,524,561.50</u>
TOTAL DISBURSEMENTS IN PERIOD			<u><u>\$ 8,021,169.97</u></u>

I certify that the disbursements listed on the attached check registers and listing of ACH debits, wire transfers, and P-Card purchases were payments made for obligations of The School District of the City of Hazel Park and that all materials or services listed on the invoices have been received or performed.

Jason Zirmis
Assistant Superintendent, Business & Operations

Monthly Summary of EFT's from HP Bank Accounts

Oct-21

<u>Date</u>	<u>Amount</u>	<u>Bank Acct Taken From</u>	<u>Reason</u>
10/4/2021	\$315.30	Gen Funds	Latchkey Fees
10/15/2021	\$285.65	Gen Funds	AFLAC Payment October 8th Payroll
10/26/2021	\$201.47	Gen Funds	AFLAC Payment October 22nd Payroll
10/8/2021	\$3,550.66	Gen Funds	Health Equity Payment October 8th Payroll
10/7/2021	\$5,203.80	Gen Funds	EduStaff Payment
10/21/2021	\$7,599.20	Gen Funds	EduStaff Payment
10/12/2021	\$18,040.47	Gen Funds	Penserv Payment August 27th Payroll
10/22/2021	\$17,834.12	Gen Funds	Penserv Payment October 8th Payroll
10/8/2021	\$32,264.65	Tax W/H	Payroll State Tax Withholding October 8th
10/2/2021	\$31,699.80	Tax W/H	Payroll State Tax Withholding October 22nd
10/8/2021	\$211,916.52	Tax W/H	Payroll Federal Tax Withholding October 8th
10/22/2021	\$207,647.51	Tax W/H	Payroll Federal Tax Withholding October 22nd
10/14/2021	\$343,866.85	Ret W/H	Payroll Retirement Withholding October 8th
10/22/2021	\$301,469.46	Ret W/H	Payroll Retirement Withholding October 22nd
10/18/2021	\$18,724.44	DTE	September DTE Payments
10/27/2021	\$2,047.66	Consumers	September Consumers Payments

\$1,205,858.22 Total ACH Debits

<u>Date</u>	<u>Amount</u>	<u>Payroll</u>
10/8/2021	\$633,931.43	General Payroll on October 8th
10/22/2021	\$617,152.47	General Payroll on October 22nd

\$1,251,083.90 Total Payroll

<u>Date</u>	<u>Amount</u>	<u>Wires</u>
10/22/2021	\$2,570,399.75	MVCA Wire State Aid

\$2,570,399.75 Total Wires

<u>Date</u>	<u>Amount</u>	<u>P-Card Purchases</u>
10/21/2021	\$270,357.34	General P-Card charges Huntington Bank

\$270,357.34 Total P-Card Purchases

Hazel Park Schools
Budget to Actual by St Revenue and St Function
As of 10/31/2021

St Revenue/Function	Description	Original Budget	Encumbrance	Actual	Balance	Percent
Type: 4 Revenue						
St Revenue: 100	Revenue from Local Sources	Total: 5,565,278.40	0.00	3,097,770.05	2,467,508.35	55.66%
St Revenue: 300	Rev from State Sources	Total: 27,440,953.46	0.00	2,538,644.89	24,902,308.57	9.25%
St Revenue: 400	Rev from Federal Sources	Total: 5,323,130.00	0.00	1,149,200.00	4,173,930.00	21.59%
St Revenue: 500	Incoming Transfer/Oth Transact	Total: 2,380,209.40	0.00	274,174.00	2,106,035.40	11.52%
St Revenue: 600	Fund Modifications	Total: 1,569,040.36	0.00	0.00	1,569,040.36	0.00%
Type: 4	RevenueTotal:	42,278,611.62	0.00	7,059,788.94	35,218,822.68	16.70%
Type: 5 Expense						
St. Function:110	Basic Programs	Total: 19,059,579.88	134,413.60	4,295,143.87	14,764,436.01	22.54%
St. Function:120	Added Needs	Total: 8,221,581.26	1,425.00	1,620,959.24	6,600,622.02	19.72%
St. Function:210	Support Services-Pupil	Total: 2,449,653.37	4,710.02	678,352.54	1,771,300.83	27.69%
St. Function:220	Support Services-Instr Staff	Total: 1,610,429.25	3,318.03	788,032.13	822,397.12	48.93%
St. Function:230	Support Services-General Admin	Total: 646,988.52	8,047.40	236,807.96	410,180.56	36.60%
St. Function:240	Support Services-School Admin	Total: 2,081,369.84	857.65	578,551.36	1,502,818.48	27.80%
St. Function:250	Support Services-Business	Total: 757,166.28	2,173.27	260,327.48	496,838.80	34.38%
St. Function:260	Operations and Maintenance	Total: 4,471,426.19	150,291.85	1,646,914.10	2,824,512.09	36.83%
St. Function:270	Pupil Transportation Services	Total: 317,126.07	0.00	93,117.31	224,008.76	29.36%
St. Function:280	Support Services-Central	Total: 1,325,197.03	1,199.66	527,680.83	797,516.20	39.82%
St. Function:290	Support Services-Other	Total: 580,337.23	26,736.78	81,216.41	499,120.82	13.99%
St. Function:330	Community Activities	Total: 15,912.00	28,456.00	1,620.00	14,292.00	10.18%
St. Function:390	Other Community Services	Total: 57,846.47	0.00	26,254.02	31,592.45	45.39%
St. Function:440	Pymts to Other Govmnt	Total: 209,706.64	0.00	266,665.00	-56,958.36	127.16%
St. Function:510	Debt Services - Long Term Only	Total: 33,000.00	0.00	33,000.00	0.00	100.00%
St. Function:600	Transfers Out	Total: 292,088.00	0.00	23,043.75	269,044.25	7.89%
Type: 5	ExpenseTotal:	42,129,408.03	361,629.26	11,157,686.00	30,971,722.03	26.48%
Grand Total:		149,203.59	-361,629.26	-4,097,897.06	4,247,100.65	

Hazel Park Schools

Check Register by Fund

Check Date From 10/1/2021 TO 10/31/2021

Check Date	Check#	PE ID	Vendor Name	PO#	Amount
Fund: 110					
10/07/2021	EH 00000131	100431	CLARK HILL PLLC		1,497.50
10/07/2021	EH 00000132	100056	HINTON, BEVERLY	P2200007	25.00
10/07/2021	EH 00000133	100044	HP PROMISE ZONE	P2200012	25.00
10/07/2021	EH 00000134	100860	MELISSA BALDWIN	P2200005	25.00
10/07/2021	EH 00000135	100125	SCHLAK, KRISTY	P2200017	25.00
10/07/2021	EH 00000136	100397	SCHOOL SPECIALTY	P2200107	1,906.69
10/07/2021	EH 00000137	100504	SET INC.		48,248.66
10/07/2021	EH 00000138	100357	STAPLES BUSINESS ADVANTGE	P2200102	134.16
10/07/2021	HP 00500430	100049	5 STAR OUTDOOR LLC		1,800.00
10/07/2021	HP 00500431	100550	AMAZON CAPITAL SERVICES INC	P2200120	2,043.42
10/07/2021	HP 00500432	100551	AMAZON COM SERVICES INC	P2200140	22.77
10/07/2021	HP 00500433	100969	ANDREW MARTIN		80.00
10/07/2021	HP 00500434	100350	ASCENSION MICHIGAN AT WORK		246.00
10/07/2021	HP 00500435	100544	ASCENSION MICHIGAN AT WORK		132.00
10/07/2021	HP 00500436	100346	BIG D LOCK & KEY	P2200030	166.50
10/07/2021	HP 00500437	100512	CHAPT 13 TRUSTEE-TAMMY L TERRY		420.00
10/07/2021	HP 00500438	100011	CHAPTER 13 TRUSTEE		108.00
10/07/2021	HP 00500439	100111	CLARK, DENNIS		120.00
10/07/2021	HP 00500440	100953	DAVID BADER P67307		166.86
10/07/2021	HP 00500441	100625	DAVID MAGIERA		225.00
10/07/2021	HP 00500442	100609	DAVID RUSKIN		1,127.58
10/07/2021	HP 00500443	100031	DEAF COMMUNITY ADVOCACY NETWORK		220.00
10/07/2021	HP 00500444	100523	DICK BLICK		484.40
10/07/2021	HP 00500445	100976	DRAMATISTS PLAY SERVICE INC		390.00
10/07/2021	HP 00500446	100718	GRACENOTES LLC		35.00
10/07/2021	HP 00500447	100008	HAZEL PARK YOUTH ASSISTANCE	P2200006	25.00
10/07/2021	HP 00500448	100487	HEINEMANN	P2200085	7,252.43
10/07/2021	HP 00500449	100521	INTERNATIONAL PLUMBING CO		765.00
10/07/2021	HP 00500450	100968	JAMMARR HANES		40.00
10/07/2021	HP 00500451	100971	KRISTINA HERRON		110.00

Current Date: 11/09/2021
Current Time: 09:08:51

Page 1

User: MILLERM - Matthew Miller
Report: OSAP5009 - OSAP5009: Check Register by Fund
Selection:

OH_DTL.[oh_ek_dt] <= '10/31/2021' AND OH_DTL.[oh_ek_dt] >= '10/01/2021'

Hazel Park Schools

Check Register by Fund

Check Date From 10/1/2021 TO 10/31/2021

Check Date	Check#	PE ID	Vendor Name	PO#	Amount
10/07/2021	HP 00500452	100433	LAKESHORE LEARNING MATERIALS	P2200132	318.00
10/07/2021	HP 00500453	100413	MCGRAW HILL BOOK CO		508.37
10/07/2021	HP 00500454	100327	MICHIGAN EDUCATION SPECIAL		305,452.59
10/07/2021	HP 00500455	100352	MICHIGAN SCHOOL BAND		375.00
10/07/2021	HP 00500456	100387	MISDU		912.65
10/07/2021	HP 00500457	100850	MRO BUILT		6,355.00
10/07/2021	HP 00500458	100380	OAKLAND SCHOOLS	P2200066	3,191.00
10/07/2021	HP 00500459	100380	OAKLAND SCHOOLS	P2200066	1,561.00
10/07/2021	HP 00500460	100021	PEARSON CLINICAL ASSESSMENT		246.60
10/07/2021	HP 00500462	100565	ROLAR PROPERTY SERVICES INC.		8,250.00
10/07/2021	HP 00500463	100973	SCOTT GUTHRIE		40.00
10/07/2021	HP 00500464	100740	SPECTRUM WIRELESS USA INC		55.00
10/07/2021	HP 00500466	100573	T T COMPUTERS COMMUNICATION INC		1,357.35
10/21/2021	EH 00000139	100045	A & I ENTERPRISES		161,078.88
10/21/2021	EH 00000141	100574	INSTITUTE FOR EXCELLENCE IN ED	P2200009	1,500.00
10/21/2021	EH 00000142	100292	INVEST CENTERS LLC		218,872.19
10/21/2021	EH 00000143	100520	PEDIATRIC HEALTH CONSULTANTS INC		6,100.00
10/21/2021	EH 00000144	100397	SCHOOL SPECIALTY	P2200145	648.47
10/21/2021	EH 00000145	100504	SET INC.		37,292.00
10/21/2021	EH 00000146	100357	STAPLES BUSINESS ADVANTGE	P2200157	353.91
10/21/2021	HP 00500467	100090	A G CENTRAL MUSIC	P2200141	139.00
10/21/2021	HP 00500468	100458	ACE TRANSPORTATION		1,120.00
10/21/2021	HP 00500469	100550	AMAZON CAPITAL SERVICES INC	P2200148	13,058.45
10/21/2021	HP 00500470	100551	AMAZON COM SERVICES INC	P2200125	289.64
10/21/2021	HP 00500471	100290	ASCENSION MICHIGAN AT WORK		700.00
10/21/2021	HP 00500472	100406	BALFOUR COLL		69.95
10/21/2021	HP 00500474	100735	BURKES SPORT HAVEN		785.95
10/21/2021	HP 00500475	100984	C & P TREE SERVICE		2,500.00
10/21/2021	HP 00500476	100526	CAROLINA BIOLOGICAL SUPPLY CO	P2200064	4.48
10/21/2021	HP 00500477	100512	CHAPT 13 TRUSTEE-TAMMY L TERRY		420.00
10/21/2021	HP 00500478	100011	CHAPTER 13 TRUSTEE		108.00

Current Date: 11/09/2021
Current Time: 09:08:51

Page 2

User: MILLERM - Matthew Miller
Report: OSAP5009 - OSAP5009: Check Register by Fund
Selection:

OH_DTL.[oh_ek_dt] <= '10/31/2021' AND OH_DTL.[oh_ek_dt] >= '10/01/2021'

Hazel Park Schools

Check Register by Fund

Check Date From 10/1/2021 TO 10/31/2021

Check Date	Check#	PE ID	Vendor Name	PO#	Amount
10/21/2021	HP 00500479	100111	CLARK, DENNIS		120.00
10/21/2021	HP 00500480	100985	CLIA LABORATORY		180.00
10/21/2021	HP 00500481	100812	CONTRACT PAPER GROUP	P2200104	1,029.20
10/21/2021	HP 00500482	100953	DAVID BADER P67307		166.86
10/21/2021	HP 00500483	100625	DAVID MAGIERA		200.00
10/21/2021	HP 00500484	100609	DAVID RUSKIN		1,127.58
10/21/2021	HP 00500486	100446	FAR THERAPEUTIC & PERFORMING ARTS	P2200059	181.36
10/21/2021	HP 00500487	100640	FIBER LINK INC		279.00
10/21/2021	HP 00500488	100079	INTEGRITY TESTING & SAFETY ADM		97.00
10/21/2021	HP 00500489	100839	K 12 MANAGEMENT DBA FuelEd		20,950.00
10/21/2021	HP 00500490	100971	KRISTINA HERRON		110.00
10/21/2021	HP 00500491	100433	LAKESHORE LEARNING MATERIALS	P2200156	160.98
10/21/2021	HP 00500492	100072	MAKEMUSIC INC	P2200101	2,488.24
10/21/2021	HP 00500493	100413	MCGRAW HILL BOOK CO	P2200061	280.59
10/21/2021	HP 00500494	100387	MISDU		912.65
10/21/2021	HP 00500495	100040	NZY	P2200153	199.68
10/21/2021	HP 00500496	100380	OAKLAND SCHOOLS		1,897.33
10/21/2021	HP 00500497	100000	OFFICE DEPOT	P2200088	234.55
10/21/2021	HP 00500498	100021	PEARSON CLINICAL ASSESSMENT	P2200152	602.32
10/21/2021	HP 00500499	100947	PIONEER RESEARCH		449.60
10/21/2021	HP 00500501	100525	ROBERT BROOKE & ASSOCIATES INC	P2200091	503.27
10/21/2021	HP 00500502	100370	ROVIN CERAMICS	P2200113	1,733.38
10/21/2021	HP 00500503	100599	School Nurse Supply Inc	P2200100	273.82
10/21/2021	HP 00500504	100973	SCOTT GUTHRIE		40.00
10/21/2021	HP 00500505	100408	SEXTON ENTERPRIZE INC		425.00
10/21/2021	HP 00500506	100749	SONITROL GREAT LAKES		279.84
10/21/2021	HP 00500507	100740	SPECTRUM WIRELESS USA INC	P2200106	275.00
10/21/2021	HP 00500509	100613	WARREN FITZGERALD HIGH SCHOOL		250.00
10/21/2021	HP 00500510	100463	WINDSTREAM		980.12
Fund 110 Total:					877,957.82

Fund: 220

User: MILLERM - Matthew Miller Page 3
 Report: OSAP5009 - OSAP5009: Check Register by Fund
 Selection: OH_DTL.[oh_ek_dt] <= '10/31/2021' AND OH_DTL.[oh_ek_dt] >= '10/01/2021'
 Current Date: 11/09/2021
 Current Time: 09:08:51

Hazel Park Schools

Check Register by Fund

Check Date From 10/1/2021 TO 10/31/2021

Check Date	Check#	PE ID	Vendor Name	PO#	Amount
10/07/2021	HP 00500431	100550	AMAZON CAPITAL SERVICES INC		1,259.87
10/07/2021	HP 00500461	100543	PETTY CASH		259.14
10/07/2021	HP 00500465	100515	STAFF CONNECTIONS LLC		5,454.00
10/21/2021	EH 00000143	100520	PEDIATRIC HEALTH CONSULTANTS INC		2,091.30
10/21/2021	EH 00000146	100357	STAPLES BUSINESS ADVANTGE	P2200131	264.35
10/21/2021	HP 00500469	100550	AMAZON CAPITAL SERVICES INC		1,136.47
10/21/2021	HP 00500486	100446	FAR THERAPEUTIC & PERFORMING ARTS	P2200059	3,532.39
10/21/2021	HP 00500498	100021	PEARSON CLINICAL ASSESSMENT	P2200046	404.60
10/21/2021	HP 00500508	100515	STAFF CONNECTIONS LLC		5,486.50
			Fund 220 Total:		19,888.62
Fund: 250					
10/21/2021	EH 00000140	100118	CHARTWELLS DINING SERVICES		162,324.93
10/21/2021	HP 00500500	100954	RITEWAY SERVICE INC		1,285.21
			Fund 250 Total:		163,610.14
Fund: 290					
10/21/2021	HP 00500473	100266	BIANCHI PHOTO & BANNER		455.00
10/21/2021	HP 00500474	100735	BURKES SPORT HAVEN		85.00
			Fund 290 Total:		540.00
Fund: 420					
10/21/2021	HP 00500485	100038	DELTA NETWORK SERVICES LLC	P2200001	15,590.40
			Fund 420 Total:		15,590.40
Fund: 460					
10/21/2021	EH 00000147	100880	VOLUME CASES	P2200146	19,925.66
			Fund 460 Total:		19,925.66
			Grand Total:		1,097,512.64

End of Report

Huntington Bank
Commercial Card Summary (P-Card)
For Month Ending - October 2021

<u>Date of Trans</u>	<u>Card Holder</u>	<u>Vendor</u>	<u>Amount</u>
10/31/2021	MEGAN PAPASIAN-BROADWELL	AMZN MKTP US*HQ89D25N3	24.93
10/31/2021	MEGAN PAPASIAN-BROADWELL	AMZN MKTP US*GU19Z5G73	25.95
10/31/2021	MEGAN PAPASIAN-BROADWELL	AMZN MKTP US*UL12X4K23	99.99
10/31/2021	MEGAN PAPASIAN-BROADWELL	AMZN MKTP US*2U4SV4MO3	11.39
10/31/2021	GREG RICHARDSON	TONYS ACE HDWE	6.26
10/31/2021	ACCOUNTS PAYABLE	INCLUSIVE TLC SPECIAL	299.00
10/31/2021	GREG RICHARDSON	TONYS ACE HDWE	32.28
10/31/2021	CHRISTINE LUPTAK	VIGILANTE SECURITY INC	1,089.00
10/31/2021	MEGAN PAPASIAN-BROADWELL	AMZN MKTP US*468JZ1O63	47.99
10/31/2021	MEGAN PAPASIAN-BROADWELL	ESPECIALNEE	824.95
10/31/2021	CORRI NASTASI	APPLE FRITTER DOUGHNUT	349.44
10/31/2021	THOMAS OESTRIKE	MR. MIGUELS	(13.34)
10/31/2021	ROCHELLE TASSIE	LITTLE CAESARS #0030	42.40
10/31/2021	MEGAN PAPASIAN-BROADWELL	HOBBY-LOBBY # 419	59.54
10/31/2021	MEGAN PAPASIAN-BROADWELL	MEIJER # 222	43.41
10/29/2021	MEGAN PAPASIAN-BROADWELL	SQ *DEBBY'S DOLLAR	68.50
10/29/2021	MEGAN PAPASIAN-BROADWELL	AMZN MKTP US*EY7SB1WV3	99.90
10/29/2021	BRADLEY WILKINS	TOBII DYNVOX SYSTEMS	487.00
10/29/2021	THOMAS OESTRIKE	MR. MIGUELS	200.00
10/29/2021	THOMAS OESTRIKE	MR. MIGUELS	35.76
10/28/2021	AMY KRUPPE	ENGAGING SCHOOLS INC	352.80
10/28/2021	MEGAN PAPASIAN-BROADWELL	ADOBE PRODUCTS	9.99
10/28/2021	JAMIE BUCZKO	WALMART.COM AA	44.56
10/28/2021	DEBRA DIMAS	WF* WAYFAIR 3646007672	718.56
10/28/2021	THOMAS OESTRIKE	EDDIES PIZZA	35.41
10/27/2021	STEPHANIE DULMAGE	TEACHING STRATEGIES,LL	279.58
10/27/2021	MEGAN PAPASIAN-BROADWELL	AMZN MKTP US*LZ5U67AQ3	35.00
10/27/2021	MEGAN PAPASIAN-BROADWELL	AMZN MKTP US*LZ5U67AQ3	34.99
10/27/2021	BRADLEY WILKINS	SWANK MOTION PICTURES	3,406.00
10/27/2021	MEGAN PAPASIAN-BROADWELL	MEIJER # 222	13.11
10/26/2021	CORRI NASTASI	TST* NEW YORK BAGEL -	100.00
10/26/2021	TAMMY SCHOLZ	MASSP & MASC/MAHS	150.00
10/26/2021	MEGAN PAPASIAN-BROADWELL	MYBINDING.COM	187.36
10/26/2021	GREG RICHARDSON	TONYS ACE HDWE	1.40
10/26/2021	CORRI NASTASI	SAMS CLUB #6657	197.50
10/25/2021	DEBRA DIMAS	LEARNING GIZMO S INC	27.56
10/25/2021	SHEILA OKANE	OTC BRANDS INC	104.77
10/24/2021	CORRI NASTASI	SAMSCLUB #6659	8.48
10/24/2021	CORRI NASTASI	SAMS CLUB #6659	164.16
10/24/2021	DEBRA DIMAS	AMAZON.COM*2Y8L377T0	30.95
10/24/2021	AMY KRUPPE	WPY*DIVERSIFIED MANAGE	99.00
10/24/2021	JASON ZIRNIS	UNIVERSAL WHOLESALE PL	23.85
10/24/2021	GREG RICHARDSON	TONYS ACE HDWE	20.89
10/24/2021	GINA BREW	SULLIVANS FLEET SERVIC	450.12
10/24/2021	GINA BREW	SULLIVANS FLEET SERVIC	4,389.17
10/24/2021	THOMAS OESTRIKE	GFS STORE #0950	94.19
10/24/2021	THOMAS OESTRIKE	GFS STORE #0178	459.84
10/24/2021	CHRISTINE LUPTAK	ORKIN LLC 002	123.00
10/24/2021	ROCHELLE TASSIE	OTC BRANDS INC	58.83
10/22/2021	STEPHANIE DULMAGE	TEACHING STRATEGIES,LL	330.00
10/22/2021	THOMAS OESTRIKE	PAYPAL *DFX DANCE	308.00
10/22/2021	THOMAS OESTRIKE	PAYPAL *DFX DANCE	508.00
10/22/2021	MATTHEW MILLER	INTEGRITY BUSINESS SOL	107.30
10/22/2021	CHRISTINE LUPTAK	APOC SALES INC.	1,949.01
10/22/2021	CHRISTINE LUPTAK	GEMINI FORMS AND SYSTE	37.80

10/21/2021	ACCOUNTS PAYABLE	SAVVAS LEARNING	4,843.25
10/21/2021	MEGAN PAPASIAN-BROADWELL	DOLLAR TREE	65.00
10/21/2021	CORRI NASTASI	AMAZON.COM*2Y2S70L92	112.90
10/21/2021	CHRISTINE LUPTAK	BIGD LOCK & KEY	34.50
10/21/2021	CHRISTINE LUPTAK	BILLINGS LAWN EQUIPMEN	188.13
10/20/2021	BRADLEY WILKINS	AMPLIFIED IT, LLC	1,854.00
10/20/2021	GREG RICHARDSON	TONYS ACE HDWE	28.46
10/20/2021	JAMIE BUCZKO	OAKLAND SCHOOLS-RC INT	300.00
10/20/2021	CORRI NASTASI	AMZN MKTP US*2Y72F9PZ1	49.98
10/20/2021	CORRI NASTASI	USPS.COM POSTAL STORE	60.00
10/20/2021	MATTHEW MILLER	SONITROL GREAT LAKES M	294.98
10/20/2021	MATTHEW MILLER	INSTENT INDUSTRIES	8,638.10
10/20/2021	MATTHEW MILLER	COMMUNICATION MATRIX	25.00
10/20/2021	MICHELLE KRAUSE	GFS STORE #0240	115.88
10/19/2021	CORRI NASTASI	TST* NEW YORK BAGEL -	100.00
10/19/2021	MEGAN PAPASIAN-BROADWELL	AMZN MKTP US*2Y5QA2A01	85.35
10/19/2021	MEGAN PAPASIAN-BROADWELL	SAMSCLUB #6659	13.88
10/19/2021	MEGAN PAPASIAN-BROADWELL	SAMSCLUB #6659	18.22
10/19/2021	MEGAN PAPASIAN-BROADWELL	SAMSCLUB #6659	102.13
10/19/2021	ACCOUNTS PAYABLE	CLEAR RATE COMMUNICATI	1,884.56
10/19/2021	ROCHELLE TASSIE	ALLSTAR SERVICES OF MI	150.00
10/18/2021	MEGAN PAPASIAN-BROADWELL	AMZN MKTP US*2Y29J0JP1	67.87
10/18/2021	MEGAN PAPASIAN-BROADWELL	AMZN MKTP US*2Y1C16ZC0	34.98
10/18/2021	BRADLEY WILKINS	DRI*ISUMSOFT	31.75
10/18/2021	CORRI NASTASI	AMAZON.COM*2Y4PP0JP1	22.58
10/18/2021	CORRI NASTASI	AMAZON.COM*2Y0O08331	23.63
10/18/2021	CORRI NASTASI	SAMS CLUB #6664	51.10
10/17/2021	JAMIE BUCZKO	BURLINGTON STORES 356	275.81
10/17/2021	JAMIE BUCZKO	MI ASSOC SCH ADM	125.00
10/17/2021	CORRI NASTASI	AMZN MKTP US*277039SF2	17.99
10/17/2021	CORRI NASTASI	AMZN MKTP US*2Y49N34B0	35.98
10/17/2021	CHRISTINE LUPTAK	REPUBLIC SERVICES TRAS	4,103.24
10/17/2021	ROCHELLE TASSIE	JOANN STORES #690	(8.57)
10/17/2021	GREG RICHARDSON	TONYS ACE HDWE	14.24
10/17/2021	MEGAN PAPASIAN-BROADWELL	MFASCO HEALTH & SAFETY	451.36
10/17/2021	MEGAN PAPASIAN-BROADWELL	AMZN MKTP US*277AS68A2	29.65
10/17/2021	MEGAN PAPASIAN-BROADWELL	AMZN MKTP US*274OW0Y90	45.89
10/17/2021	ACCOUNTS PAYABLE	REPUBLIC SERVICES TRAS	222.82
10/17/2021	ACCOUNTS PAYABLE	TMOBILE*AUTO PAY	353.59
10/17/2021	MATTHEW MILLER	PROJECT LEAD THE WAY,	253.50
10/17/2021	MATTHEW MILLER	SCHOLASTIC, INC.	186.78
10/17/2021	MATTHEW MILLER	SCHOLASTIC, INC.	21.78
10/17/2021	MATTHEW MILLER	SCHOLASTIC, INC.	130.90
10/17/2021	MATTHEW MILLER	PORTA PHONE COMPANY	277.17
10/17/2021	ACCOUNTS PAYABLE	CORRIGAN MOVING SYSTEM	292.00
10/17/2021	MATTHEW MILLER	DTE ENERGY	576.49
10/17/2021	MATTHEW MILLER	DTE ENERGY	1,146.18
10/17/2021	THOMAS OESTRIKE	WOODWORK CAREER ALLIAN	103.00
10/17/2021	CHRISTINE LUPTAK	GRAINGER	263.12
10/17/2021	MEGAN PAPASIAN-BROADWELL	MEIJER # 222	11.80
10/15/2021	TAMMY SCHOLZ	AMZN MKTP US*2769I6I10	13.44
10/15/2021	TAMMY SCHOLZ	AMZN MKTP US*272YU0YS1	9.44
10/15/2021	TAMMY SCHOLZ	AMAZON.COM*275KE7U70 A	111.24
10/15/2021	MEGAN PAPASIAN-BROADWELL	AMZN MKTP US*273IL3WK1	69.96
10/15/2021	MEGAN PAPASIAN-BROADWELL	AMZN MKTP US*272BZ7WU1	105.98
10/15/2021	GREG RICHARDSON	TONYS ACE HDWE	34.19
10/15/2021	GREG RICHARDSON	TONYS ACE HDWE	9.49
10/15/2021	SHEILA OKANE	LIBIB.COM	11.00
10/14/2021	ROCHELLE TASSIE	AMZN MKTP US*278DU4XX2	21.84
10/14/2021	ROCHELLE TASSIE	DOLLARTREE	11.00
10/14/2021	ROCHELLE TASSIE	JOANN STORES #690	41.17

10/14/2021	MEGAN PAPASIAN-BROADWELL	AMZN MKTP US*279Z83VC2	17.98
10/14/2021	BRADLEY WILKINS	MSBO	85.00
10/14/2021	GREG RICHARDSON	TONYS ACE HDWE	18.98
10/14/2021	GREG RICHARDSON	TONYS ACE HDWE	33.20
10/14/2021	GREG RICHARDSON	TONYS ACE HDWE	163.21
10/14/2021	DEBRA SCOTT	MICHIGANASS	290.00
10/14/2021	ROCHELLE TASSIE	AMZN MKTP US*2775A4VQ2	8.41
10/14/2021	TAMMY SCHOLZ	BURKE S SPORTS HAVEN	503.60
10/13/2021	BRADLEY WILKINS	APPLE.COM/US	104.94
10/13/2021	BRADLEY WILKINS	APPLE.COM/US	104.94
10/13/2021	CORRI NASTASI	TST* NEW YORK BAGEL -	100.00
10/13/2021	ACCOUNTS PAYABLE	CONSUMERS ENERGY CO	238.71
10/13/2021	ACCOUNTS PAYABLE	CONSUMERS ENERGY CO	271.89
10/13/2021	CHRISTINE LUPTAK	NATASSOC4EDUYNGCHD	66.00
10/13/2021	ROCHELLE TASSIE	DOLLAR TREE	20.00
10/12/2021	TAMMY SCHOLZ	AMAZON.COM*278AL1Q31 A	249.75
10/12/2021	MEGAN PAPASIAN-BROADWELL	SAMS CLUB #6659	69.90
10/12/2021	MEGAN PAPASIAN-BROADWELL	KROGER #447	30.92
10/12/2021	JASON ZIRNIS	FEDERAL PIPE & SUPPLY	172.00
10/12/2021	JASON ZIRNIS	AMZN MKTP US*2710W1TL2	1,990.58
10/12/2021	JASON ZIRNIS	AMZN MKTP US*270IL15H0	839.88
10/12/2021	MICHELLE KRAUSE	SCHOLASTIC EDUCATION	1.50
10/12/2021	MICHELLE KRAUSE	SCHOLASTIC EDUCATION	17.98
10/12/2021	GREG RICHARDSON	TONYS ACE HDWE	24.69
10/12/2021	GREG RICHARDSON	TONYS ACE HDWE	8.72
10/12/2021	GREG RICHARDSON	TONYS ACE HDWE	8.54
10/12/2021	MATTHEW MILLER	MSBO	360.00
10/12/2021	CHRISTINE LUPTAK	VIGILANTE SECURITY INC	379.00
10/12/2021	CHRISTINE LUPTAK	STAX *BISON PLUMBING	10,500.00
10/12/2021	CHRISTINE LUPTAK	HAGOPIAN CLEANING - AC	99.00
10/11/2021	ACCOUNTS PAYABLE	TMOBILE*AUTO PAY	2,000.00
10/11/2021	CORRI NASTASI	WAL-MART #3487	38.67
10/10/2021	BRADLEY WILKINS	LEARNING WITHOUT TEARS	80.00
10/10/2021	GREG RICHARDSON	TONYS ACE HDWE	66.47
10/10/2021	ACCOUNTS PAYABLE	CONSUMERS ENERGY CO	19.50
10/10/2021	ACCOUNTS PAYABLE	CONSUMERS ENERGY CO	110.93
10/10/2021	DEBRA DIMAS	AMZN MKTP US*274M14G61	23.99
10/10/2021	THOMAS OESTRIKE	PEPSIBEVERAGECO	869.68
10/10/2021	CHRISTINE LUPTAK	CONTRACTORS NAT LAD/CO	825.47
10/10/2021	CHRISTINE LUPTAK	AIRGAS USA, LLC	157.38
10/10/2021	CHRISTINE LUPTAK	CONTRACTORS NAT LAD/CO	2,954.34
10/10/2021	CHRISTINE LUPTAK	APOC SALES INC.	3,924.00
10/08/2021	TAMMY SCHOLZ	AMAZON.COM*2764I8E41 A	44.60
10/08/2021	STEPHANIE DULMAGE	LEARNING A-Z, LLC	950.00
10/08/2021	MICHELLE KRAUSE	SCHOLASTIC EDUCATION	113.81
10/08/2021	BRADLEY WILKINS	SQ *LION TECHNOLOGIES	2,000.00
10/08/2021	BRADLEY WILKINS	APPLE.COM/BILL	105.99
10/08/2021	GREG RICHARDSON	TONYS ACE HDWE	65.53
10/08/2021	CHRISTINE LUPTAK	BILLINGS LAWN EQUIPMEN	20.64
10/08/2021	CHRISTINE LUPTAK	SQ *MECHANICAL SYSTEM	6,031.80
10/08/2021	CHRISTINE LUPTAK	SQ *MECHANICAL SYSTEM	350.00
10/08/2021	CHRISTINE LUPTAK	GRAINGER	103.68
10/08/2021	CHRISTINE LUPTAK	STAX *BISON PLUMBING	110.00
10/08/2021	CHRISTINE LUPTAK	MCNAUGHTON MCKAY ELECT	1,091.09
10/08/2021	CHRISTINE LUPTAK	DOWNRIVER REFRIGERATIO	1,182.52
10/08/2021	CHRISTINE LUPTAK	ROYAL ROOFING INC	468.00
10/08/2021	CHRISTINE LUPTAK	ROYAL ROOFING INC	453.00
10/08/2021	CHRISTINE LUPTAK	ROYAL ROOFING INC	279.00
10/08/2021	CHRISTINE LUPTAK	GNE PAINT & SUPPLIES I	94.47
10/08/2021	CHRISTINE LUPTAK	MSBO	150.00
10/08/2021	CHRISTINE LUPTAK	INTEGRITY BUSINESS SOL	429.44

10/07/2021	TAMMY SCHOLZ	AMAZON.COM*275PU0NG0 A	44.60
10/07/2021	ACCOUNTS PAYABLE	SAVVAS LEARNING	1,298.41
10/07/2021	BRADLEY WILKINS	METALCRAFT, INC.	20.69
10/07/2021	BRADLEY WILKINS	SQ *LION TECHNOLOGIES	2,000.00
10/07/2021	NICK NUGENT	IDENTOGO - MI FINGERPR	67.25
10/07/2021	ACCOUNTS PAYABLE	J.W. PEPPER	105.00
10/07/2021	ACCOUNTS PAYABLE	STAFFORD SMITH, INC	17,111.00
10/07/2021	ACCOUNTS PAYABLE	CONSUMERS ENERGY CO	97.96
10/07/2021	THOMAS OESTRIKE	WEISSMAN'S THEATRICAL	331.89
10/07/2021	CHRISTINE LUPTAK	BATTERY CENTERS	54.00
10/07/2021	CHRISTINE LUPTAK	KILBURNS EQUIPMENT REN	41.90
10/07/2021	ROCHELLE TASSIE	AMAZON.COM*2C1FF8IO2 A	41.98
10/07/2021	BRADLEY WILKINS	JUMPCLOUD INC	114.00
10/07/2021	CHRISTINE LUPTAK	WEINGARTZ	279.79
10/06/2021	CORRI NASTASI	TST* NEW YORK BAGEL -	100.00
10/06/2021	TAMMY SCHOLZ	SAMSCLUB #6659	105.69
10/06/2021	TAMMY SCHOLZ	ACTE	100.00
10/06/2021	AMY KRUPPE	PREMIUM ACCESS	(35.00)
10/06/2021	BRADLEY WILKINS	METALCRAFT, INC.	1,672.79
10/06/2021	GREG RICHARDSON	TONYS ACE HDWE	25.25
10/06/2021	GREG RICHARDSON	TONYS ACE HDWE	41.94
10/06/2021	ACCOUNTS PAYABLE	CBI BALFOUR	75.13
10/06/2021	ACCOUNTS PAYABLE	A AND G CENTRAL MUSIC	120.00
10/06/2021	ACCOUNTS PAYABLE	ACCO BT USA	512.95
10/06/2021	ACCOUNTS PAYABLE	CONSUMERS ENERGY CO	109.03
10/06/2021	ACCOUNTS PAYABLE	CONSUMERS ENERGY CO	100.49
10/06/2021	ACCOUNTS PAYABLE	CONSUMERS ENERGY CO	36.65
10/06/2021	ACCOUNTS PAYABLE	CONSUMERS ENERGY CO	93.21
10/06/2021	ACCOUNTS PAYABLE	CONSUMERS ENERGY CO	92.89
10/06/2021	ACCOUNTS PAYABLE	CONSUMERS ENERGY CO	127.70
10/06/2021	ACCOUNTS PAYABLE	CONSUMERS ENERGY CO	24.39
10/06/2021	DEBRA DIMAS	AMZN MKTP US*2C8X172K2	219.85
10/06/2021	MEGAN PAPASIAN-BROADWELL	MEIJER # 222	65.10
10/05/2021	ACCOUNTS PAYABLE	A AND G CENTRAL MUSIC	108.05
10/04/2021	TAMMY SCHOLZ	AMZN MKTP US*2C2N89HG2	179.98
10/04/2021	ROCHELLE TASSIE	AMZN MKTP US*2C1TF6HS2	57.16
10/04/2021	TAMARAN DILLARD	OAKLAND SCHOOLS-RC INT	(15.00)
10/03/2021	MEGAN PAPASIAN-BROADWELL	AMZN MKTP US	(12.99)
10/03/2021	DEBRA DIMAS	AMZN MKTP US	(167.88)
10/03/2021	BRADLEY WILKINS	SQ *LION TECHNOLOGIES	650.00
10/03/2021	JAMIE BUCZKO	REI*GREENWOODHEINEMANN	526.63
10/03/2021	ROCHELLE TASSIE	AMZN MKTP US*2C6CG9DU0	28.99
10/01/2021	TAMMY SCHOLZ	AMZN MKTP US*2C5DD78V0	196.93
10/01/2021	AMY KRUPPE	AMZN MKTP US*2C5NV08J0	161.02
10/01/2021	BRADLEY WILKINS	HEARTLAND BUSINESS SYS	3,922.24
10/01/2021	GREG RICHARDSON	TONYS ACE HDWE	21.84
10/01/2021	GREG RICHARDSON	TONYS ACE HDWE	22.76
10/01/2021	GREG RICHARDSON	TONYS ACE HDWE	12.34
10/01/2021	GREG RICHARDSON	EJ USA DETROIT	195.21
10/01/2021	JAMIE BUCZKO	CURRICULUM ASSOC	37.25
10/01/2021	JAMIE BUCZKO	SMORE.COM	149.00
10/01/2021	CHRISTINE LUPTAK	VIGILANTE SECURITY INC	1,089.00
10/01/2021	CHRISTINE LUPTAK	ORKIN LLC 002	123.00
10/01/2021	KARLA GRAESSLEY	GFS STORE #0868	534.84

122,170.45



Ford Administration
1620 E. Elza, Hazel Park, MI 48030 | 248-658-5200 | F: 248-544-5223
www.hazelparkschools.org

To: Hazel Park Board of Education
From: Dr. Amy Kruppe, Superintendent
Subject: Personnel Recommendations Report
Date: December 12, 2022

Please see the personnel actions as indicated on the *Hazel Park Board of Education Personnel Recommendations* report for the December 12, 2022 Board of Education regular meeting. The packet also includes supporting documentation.

Goal Statement - Resources

The Hazel Park School District will maximize its resources to assure high quality education by fostering financial stability, preserving and utilizing quality facilities, and integrating state-of-the-art technology.

Recommendation

That the Board of Education approve the Personnel Recommendations as presented.

**APPROVED AND RECOMMENDED FOR
BOARD ACTION**

Amy Y. Kruppe, Ed.D.
Superintendent



NAME	EVENT	DATES OF EVENT	LOCATION	ESTIMATED COST
IN STATE				(Includes Sub)
Megan Burr	Curriculum Writing Team	11/30/22	Board Office	\$0.00
Lori Bullis	Understanding and Managing Suicide in the School	12/16/22	Oakland Schools	\$15.00
Christopher Benedetto	MDE Woodworking Standards Revision for Perkins V	12/9/22 - 12/10/22	Bay City	\$259.10
Beverly Blair	CSE's National Sex Education Conference	12/13/22 - 12/15/22	Online	\$345.00
Carly Elia	ECSE 3rd Annual ECSE Childhood Conference	12/2/22	Oakland Schools	\$15.00
Dana Miller	ECSE 3rd Annual ECSE Childhood Conference	12/2/22	Oakland Schools	\$15.00
Mark Fairbrother	Media Teqacher Symposium	12/2/22	Troy, MI	\$141.60
Deanna Kulczycki	PBIS For Students with Autism	12/1/22 & 12/8/22	Virtual	\$0.00
Darcy Platt	Curriculum Writing Team	11/30/22	Board Office	\$0.00
Erika Resh	Curriculum Writing Team	11/30/22	Board Office	\$0.00
Carla Postell	Equity and Social Justice Seminar	12/7/22	Virtual	\$150.00

The School District of the City of
Hazel Park
Of Oakland County

Proposed Budget
APPROPRIATION ACT
July 1, 2022-June 30, 2023

Budget Presentatoin
Board of Education Adoption

December 12, 2022

**GENERAL FUND REVENUE
BUDGET
July 1, 2022-June 30, 2023**

	2020-2021 <u>Actual</u>	2021-2022 <u>Actual</u>	2022-2023 Original Budget <u>6/6/2022</u>	2022-2023 Proposed Amendment <u>12/9/2022</u>
Local	\$5,528,632	\$5,710,889	\$5,693,389	\$5,761,569
State	28,112,704	29,254,323	28,907,259	32,481,402
Federal	4,285,393	7,625,204	7,653,087	4,668,228
Other Transactions	<u>2,441,743</u>	<u>2,511,584</u>	<u>2,430,209</u>	<u>2,501,280</u>
	<u>\$40,368,472</u>	<u>\$45,102,000</u>	<u>\$44,683,944</u>	<u>\$45,412,479</u>

**GENERAL FUND EXPENDITURES
BUDGET**

July 1, 2022-June 30, 2023

	2020-2021 <u>Actual</u>	2021-2022 <u>Actual</u>	2022-2023 Original Budget <u>6/6/2022</u>	2022-2023 Proposed Amendment <u>12/9/2022</u>
INSTRUCTION				
Basic Programs	\$17,423,567	\$19,018,480	\$20,081,570	\$19,906,278
Added Needs	<u>6,971,562</u>	<u>7,910,625</u>	<u>9,091,790</u>	<u>9,469,621</u>
TOTAL INSTRUCTION	\$24,395,128	\$26,929,105	\$29,173,360	\$29,375,899
SUPPORT SERVICES				
Pupil	\$2,243,427	\$2,846,050	\$3,373,023	\$3,242,329
Instructional Staff	1,580,080	2,368,670	2,286,192	3,356,491
General Administration	644,770	757,674	727,389	788,039
School Administration	1,888,577	2,061,177	2,093,556	2,028,550
Business	790,879	680,521	720,526	839,654
Operation & Maintenance	6,078,882	5,268,235	5,459,796	4,544,457
Transportation	346,225	375,662	305,510	313,093
Central	1,162,113	2,184,853	1,463,268	1,403,555
Other	<u>417,830</u>	<u>512,787</u>	<u>446,886</u>	<u>481,560</u>
TOTAL SUPPORT SERVICES	\$15,152,783	\$17,055,629	\$16,876,146	\$16,997,728
Community Services	\$72,499	\$163,471	\$335,758	\$340,227
Debt Service	33,000	33,000	33,000	33,000
Payments to Subgrantee	<u>201,641</u>	<u>266,665</u>	<u>266,665</u>	<u>342,062</u>
TOTAL OTHER	\$307,141	\$463,136	\$635,423	\$715,289
GRAND TOTAL	<u>\$39,855,052</u>	<u>\$44,447,870</u>	<u>\$46,684,929</u>	<u>\$47,088,916</u>
OTHER FIN. SOURCES (USES)				
Transfers In	\$1,653,914	\$2,014,511	\$1,819,040	\$2,039,797
Transfers Out	<u>(290,713)</u>	<u>(292,088)</u>	<u>(293,388)</u>	<u>(292,088)</u>
TOTAL OTHER FIN. SOURCES (USES)	\$1,363,201	\$1,722,423	\$1,525,652	\$1,747,709
Excess (Deficit)	\$1,876,621	\$2,376,553	(\$475,333)	\$71,272
Beginning Fund Balance	1,615,439	3,492,060	5,868,613	5,868,613
Ending Fund Balance	\$3,492,060	\$5,868,613	\$5,393,280	\$5,939,885
As % of Total Expenses	8.76%	13.20%	11.55%	12.61%

**RESOLUTION FOR ADOPTION BY
THE BOARD OF EDUCATION OF THE SCHOOL DISTRICT OF THE CITY OF HAZEL PARK
2022-2023 BUDGET Amendment #1**

RESOLVED, that this resolution shall be the **GENERAL FUND** Appropriation Act of The School District of the City of Hazel Park for the fiscal year 2022-2023. A resolution to make appropriations: and to provide for the disposition of all income received by The School District of the City of Hazel Park.

BE IT FURTHER RESOLVED, that the total revenues and unappropriated fund balance estimated to be available for appropriations in the **GENERAL FUND** of The School District of the City of Hazel Park for fiscal year 2022-2023, be adopted as follows:

REVENUE

Local	5,761,569	
State	32,481,402	
Federal	4,668,228	
Other Transaction	<u>2,501,280</u>	
Total Revenue		\$45,412,479
Fund Balance as of June 30, 2022	5,868,613	
Fund Balance Available to Appropriate		<u>5,868,613</u>
TOTAL APPROPRIATED FOR GENERAL FUND		<u>\$51,281,092</u>

BE IT FURTHER RESOLVED, that **\$45,341,207** in the **GENERAL FUND** is hereby appropriated in the amounts and for the purposes set forth below

FURTHER RESOLVED, that no Board of Education member or employee of the school district shall expend any funds or obligate the expenditure of any funds except pursuant to the Appropriation Act as Adopted by the Board of Education.

EXPENDITURES

Instruction:

Basic Programs	19,906,278
Added Needs	9,469,621

Support Services:

Pupil	3,242,329
Instructional Staff	3,356,491
General Administration	788,039
School Administration	2,028,550
Business	839,654
Operation & Maintenance	4,544,457
Transportation	313,093
Central	1,403,555
Other	481,560

Community Services	340,227
--------------------	---------

Outgoing Transfers & Other Transactions	(1,747,709)
---	-------------

Debt Service and Subgrantee Payments	<u>375,062</u>
--------------------------------------	----------------

TOTAL APPROPRIATED - GENERAL FUND	<u><u>\$ 45,341,207</u></u>
--	------------------------------------

Estimated Fund Balance June 30, 2021	<u><u>\$ 5,939,885</u></u>
---	-----------------------------------

FURTHER BE IT RESOLVED, that the revenue from the levy of 18 mills on non-homestead property (with Commercial Personal Property being exempted from 12 of these 18 mills) be used to pay wages, fringe benefits, purchased services, supplies and materials, capital outlay, and for transfers to other funds or governmental entities (O.C.I.S.D.).



Ford Administration
1620 E. Elza, Hazel Park, MI 48030 | 248-658-5200 | F: 248-544-5223
www.hazelparkschools.org

To: Hazel Park Board of Education
From: Jason Zirnig, Assistant Superintendent of Business and Operations
Subject: Cafeteria and Served
Date: 12/8/2022

Funding:
Food Service and Sinking Fund

Attached is the recommendation letter from TMP Architecture resulting from the RFP for the HS Cafeteria and Served work. There was one bid that came in significantly over the project estimate. At this time based on the funds available in the Food Service Fund and Sinking Fund I am recommending the project be delayed and rebid in the summer of 2023 for the summer of 2024 with the hope the cost for undertaking the projects comes down or there is more bids to validate that the price is competitive. Currently the Food Service Fund has a Fund Balance of \$515,000, this is projected to rise by the fiscal year end to just under \$700,000 which would place a significant amount of pressure on the Sinking Fund to cover the residual costs of the project. Waiting a year would allow the Food Service Fund to grow to just under \$900,000 and be able to cover most of the allowable costs at the current pricing.

A second option would be to eliminate the window and courtyard work (egress related) at a cost of approximately \$200,000 but it would place a substantial amount of pressure on the sinking fund to cover the remaining project costs.

Funding Source: Sinking Fund and Capital Projects Fund

Resources: The Hazel Park School District will maximize its resources to assure high quality education by fostering financial stability, preserving and utilizing quality facilities, and integrating state-of-the-art technology.

Recommendation

That the Board of Education approves the deferral and rebid of the Cafeteria and Served 1 year.

**APPROVED AND RECOMMENDED FOR
BOARD ACTION**



Amy Y. Kruppe, Ed.D.
Superintendent



Re: Hazel Park High School Cafeteria and Servery Remodeling
TMP Project No. 19126C

Dear Mr. Zirniz:

On Friday, November 18, 2022, sealed bids were received and opened publicly at the Hazel Park Schools business office. TMP has thoroughly reviewed the bid and conducted a post-bid review with the sole bidder, Spartan Construction Group, Inc. It is our recommendation that the contract be awarded to, Spartan Construction Group, Inc., in the following amount:

Base Bid	<u>\$1,968,000.00</u>
Total Contract Award	\$1,968,000.00

Attached for your information are the bid tabulations, post-bid review, list of sub-contractors and schedule of values.

Sincerely,

TMP ARCHITECTURE, INC.



Kyra Copeland
Associate/Project Manager

KYC

Attachment(s)



ARCHITECTURE

BID DATE:
TMP Project
Page 1 of 1

and Servery Remodeling

Bid Security	Iran Econ. Sanctions Act	Familial Disclosure	Addendum No. 1	Addendum No. 2	Base Bid
					No Bid
					No Bid
					No Bid
Yes	Yes	Yes	Yes	Yes	\$1,968,000.00

o:\2019\19126c\misc\19126c_bid tabulation.doc

Bob Adams

Goran Kanevce

Ron DeMeester

Strategic Energy Solutions

Strategic Energy Solutions

Food Service Designs

1. Base Bid \$1,968,000.00 Include Addenda Nos: One (1), Two (2)
2. Includes Pre-Bid Minutes Yes None involved
3. Includes Pre-Bid Clarification Yes None involved
4. Alternates Yes None involved
5. Allowances Yes None involved

Allowance Description:

\$5,000 allowance included for mechanical piping alterations at Main Office horizontal heating unit.

6. Voluntary Alternates Yes None involved
7. Unit Prices Yes None involved
8. Mark-up for additional work: Self-performed 15% Material: 33
By Sub-contractor 7 1/2% Labor: _____
9. Prevailing Wages: Yes None involved
10. Davis-Bacon Act: Yes None involved
11. Union Labor: Yes No

19. a. Temporary heat required: Yes No
b. Temporary heat included: Yes No

20. Bond included Yes No

Name of Bonding Co: The Ohio Casualty Insurance Company Rating A

21. Has contractor visited site? Yes No
22. Does bid contain any qualifications or exclusions to scope of work? Yes (list below) No

23. Has Contractor reviewed insurance coverage and limits? Yes No

24. Can Contractor obtain specified coverage limits? Yes No

25. a. Does Contractor understand schedule start and completion dates? Yes No

b. Are all costs included to meet the schedule? Yes No

1) Time required for shop drawings/submittals: shop drawings within 3 - 4 weeks after award

2) Time required for material/equipment delivery: varies

3) Time required for installation/erection: varies

34

4) Long lead time items: Storefront 12 weeks, FSE 24 weeks, MUA 22 – 24 weeks, RTU 30 weeks

26. Does bid account for all overtime and shift time necessary to complete the work and meet the schedule? Yes No

24. Contractor's field organization:

28. Does Contractor understand Owner's facilities, power, storage, etc.? Yes No

Current EMR rating: .98

Name of safety representative (resume): Salvator Amato

29. Does contractor have a safety plan? Yes No

30. Does contractor understand LEED requirements specific to their scope of work?

Yes No Not Applicable

31. Is contractor aware of waste management and separation guidelines for recycling?

Yes No Not Applicable

32. Bid price summary:

a. Bid Price: \$1,968,000.00

b. Allowance included in bid price (\$5,000.00)

c.: \$

d. \$

e. \$ 35

f. \$

g. \$

TOTAL \$1,968,000.00

- Questioned if construction could begin before end of school year
- Questioned if construction crew needs to provide a Porta John or if a restroom in the building could be used. Contractors would be responsible for maintaining a clean restroom throughout construction if access is allowed.

Note: This conference is in no way intended to indicate award of contract.

For: Spartan Construction Group, Inc.

For: TMP Architecture, Inc.

Signed: Matthew Spisak

Signed: Kyra Copeland

Date: 12/01/22

Date: 12/01/2022

Matt Spisak

Kyra Copeland
Associate/Project Manager

List Of Subcontractors

Scope Of Work	Contractor
Selective Demolition	Blue Star Or Industrial Demolition
Flatwork/ Foundations	Spartan
Masonry	Brothers and Bricks Or Silverado Construction
Structural Steel	Nelson Iron Works
Carpentry	Mid Thumb Or Alpha
Glazing	Glasco
D/F/H Supplier	Howard Door
Overhead Coiling Doors	KVM
Millwork	Distinctive
Flooring	Omega Floors
Tiling	Boston Tile
Painting	Trio Painting
Signage	DMP
Food Service Equipment	Stafford Smith
Windows Shades	DCA Products
Plumbing	Complete Mechanical

Cafeteria

Demolition - Ceilings, Lights, H&V, Windows, Misc	6,000	s.f.	x	\$6.00	s.f.	\$36,000
New HVAC RTU units	2	ea.	x	\$75,000		\$150,000
HVAC Ductwork	6,000	s.f.	x	\$13.00	s.f.	\$78,000
Ceilings	6,000	s.f.	x	\$12.00	s.f.	\$72,000
LED Lighting	6,000	s.f.	x	\$15.00	s.f.	\$90,000
Masonry					L.S.	\$30,000
Exterior Doors and frames	4	ea.	x	\$6,000		\$24,000
Interior Doors and frames	6	ea.	x	\$3,000		\$18,000
Aluminum Window System	700	s.f.	x	\$80.00	s.f.	\$56,000
Paint (Epoxy)	6,000	s.f.	x	\$1.50	s.f.	\$9,000
Ceramic Wall Tile	400	s.f.	x	\$27.00	s.f.	\$10,800
Mechanical and Electrical	6,000	s.f.	x	\$15.00	s.f.	\$90,000
Sub Total Cafeteria Construction						\$663,800

Servery

Demolition - Ceilings, Lights, H&V, Windows, Misc	2,000	s.f.	x	\$6.00	s.f.	\$12,000
New HVAC - included in Cafeteria budget						
New Construction	2,000	s.f.	x	\$175.00	s.f.	\$350,000
Aluminum Window System	130	s.f.	x	\$80.00	s.f.	\$10,400
Paint (Epoxy)	2,000	s.f.	x	\$1.50	s.f.	\$3,000
Ceramic Floor Tile	2,000	s.f.	x	\$27.00	s.f.	\$54,000
Food service Equipment					L.S.	\$150,000
Sub Total Servery Construction						\$579,400

Main Office

ARCHITECT: TMP Architecture, Inc.
1191 West Square Lake Road
Bloomfield Hills, Michigan, 48302-0374
248-338-4561

BIDDER:

NAME: Spartan Construction Group Inc.
ADDRESS: 45887 Mound Rd.
Shelby Township, MI 48317
PHONE: 734-331-5061
EMAIL: matt@spartan-constructiongroup.com

BID

The undersigned, having examined the Project Site and Bidding Documents, including the Advertisement for Bids, Invitation to Bid, Instruction to Bidders, and related Contract Documents prepared by TMP Architecture, Inc. for the above mentioned project, hereby offers to enter into a Contract to perform the Work of this Project in accordance with the Contract Documents as modified, augmented, or supplemented by Addenda for the sums herein provided.

BASE BID

19126C – Cafeteria and Servery Remodeling

Lump sum bid for all work indicated in the Contract Documents excluding alternates, if any.

One million nine hundred and sixty eight thousand Dollars (\$1,968,000.00)

For the above sum and all subsequent sums in this bid form, the sum shall be shown in both words and figures. Amount in words shall govern if there is a discrepancy.



Ford Administration
1620 E. Elza, Hazel Park, MI 48030 | 248-658-5200 | F: 248-544-5223
www.hazelparkschools.org

To: Hazel Park Board of Education
From: Jason Zirnig, Assistant Superintendent of Business and Operations
Subject: Natatorium Renovation
Date: 12/8/2022

Funding:
General Fund

Attached is the recommendation letter from Partner's In Architecture (PIA) resulting from the RFP for the Natatorium

Summary of current work completed:

	<u>Pool</u>		<u>Lockerroom</u>
	<u>Tank</u>	<u>Lighting</u>	
Original Bid	877,911	298,089	543,000
Final with Changes	22,933	18,312	49,812
Base Contractor Costs	900,844	316,401	592,812
District costs	-	-	2,136
Total cost per project	900,844	316,401	594,948
Total Costs	1,217,245		
Board Approved	1,246,560		570,000
Excess Available	29,315		(24,948)

1. Board Approval for the following items Overage for asbestos remediation on the work in the bathrooms and the insulation of the pipes, with other minor drain and pipe change orders - \$24,948 in the locker room areas.
2. Approval of the new Colorado Time keeping system \$62,192 (see attached specifications)
3. Approval of the new scoreboard, \$68,437
4. Approval of the UV Water Disinfection System \$40,500 (on RFP as an alternate #1)

Total cost of the project changes is \$196,077





When looking at the pool and the total project that we are undertaking, the additions outlined above are going to enhance the overall functionality of the pool for our students, athletes and competitors. When we started this project we wanted to end with a natatorium that is State of the art and will stand on its own for years to come.

Funding Source: Sinking Fund and Capital Projects Fund

Resources: The Hazel Park School District will maximize its resources to assure high quality education by fostering financial stability, preserving and utilizing quality facilities, and integrating state-of-the-art technology.

Recommendation

That the Board of Education approves the spending of \$196,077 for the Natatorium Renovations

**APPROVED AND RECOMMENDED FOR
BOARD ACTION**

Amy Y. Kruppe, Ed.D.
Superintendent

Pool and Deck

OWNER: (Name and address)
Hazel Park Schools
1620 East Elza Avenue
Hazel Park, MI 48030-2358

ARCHITECT: (Name and address)
PARTNERS in Architecture, PLC
65 Market Street
Mount Clemens, MI 48043

CONTRACTOR: (Name and address)
Baruzzini Contracting, LLC
1281 S. Old US Hwy 23
Brighton, MI 48114

THE CONTRACT IS CHANGED AS FOLLOWS:

(Insert a detailed description of the change and, if applicable, attach or reference specific exhibits. Also include agreed upon adjustments attributable to executed Construction Change Directives.)

Provide Labor and Materials to install new ADA Certified lift for pool access.

ADD: \$14,809.00

The original Contract Sum was	\$	<u>877,911.00</u>
The net change by previously authorized Change Orders	\$	<u>8,124.00</u>
The Contract Sum prior to this Change Order was	\$	<u>886,035.00</u>
The Contract Sum will be increased by this Change Order in the amount of	\$	<u>14,809.00</u>
The new Contract Sum including this Change Order will be	\$	<u>900,844.00</u>

The Contract Time will be increased by Zero (0) days.
The new date of Substantial Completion will be

NOTE: This Change Order does not include adjustments to the Contract Sum or Guaranteed Maximum Price, or the Contract Time, that have been authorized by Construction Change Directive until the cost and time have been agreed upon by both the Owner and Contractor, in which case a Change Order is executed to supersede the Construction Change Directive.

NOT VALID UNTIL SIGNED BY THE ARCHITECT, CONTRACTOR AND OWNER.

PARTNERS in Architecture, PLC

ARCHITECT

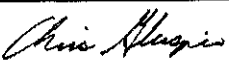

SIGNATURE

Chris Glaspie

PRINTED NAME AND TITLE

September 26, 2022

DATE

Baruzzini Contracting, LLC

CONTRACTOR (Firm name)



SIGNATURE

Tony Baruzzini

PRINTED NAME AND TITLE

9/26/2022

DATE

Hazel Park Schools

OWNER (Firm name)

44

SIGNATURE

Jason Zirnis, Asst. Superintendent for
Business & Operations

PRINTED NAME AND TITLE

DATE

Lighting

TO OWNER: (Name and address)
Hazel Park Schools
1620 E. Elza
Hazel Park , MI 48030

CONTRACT DATED: 3/3/2022

OTHER:

In accordance with the provisions of the Contract between the Owner and the Contractor as indicated above, the
(Insert name and address of Surety)

Merchants National Bonding, Inc.
P.O. Box 14498
Des Moines, IA 50306

, SURETY,

on bond of
(Insert name and address of Contractor)

R&E Development Group, LLC
70701 Powell Road
Bruce Township, MI 48065

, CONTRACTOR,

hereby approves of the final payment to the Contractor, and agrees that final payment to the Contractor shall not relieve the
Surety of any of its obligations to
(Insert name and address of Owner)

Hazel Park Schools
1620 E. Elza
Hazel Park , MI 48030

, OWNER,

as set forth in said Surety's bond.

IN WITNESS WHEREOF, the Surety has hereunto set its hand on this date: **September 14, 2022**
(Insert in writing the month followed by the numeric date and year.)

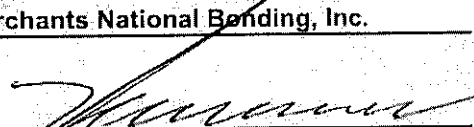
Merchants National Bonding, Inc.
(Surety)

(Signature of authorized representative)

Michael Ashburn, Attorney in Fact

or proceedings allowed by law.

This Power-of-Attorney is granted and is signed and sealed by facsimile under and by authority of the following By-Laws adopted by the Board of Directors of Merchants Bonding Company (Mutual) on April 23, 2011 and amended August 14, 2015 and adopted by the Board of Directors of Merchants National Bonding, Inc., on October 16, 2015.

"The President, Secretary, Treasurer, or any Assistant Treasurer or any Assistant Secretary or any Vice President shall have power and authority to appoint Attorneys-in-Fact, and to authorize them to execute on behalf of the Company, and attach the seal of the Company thereto, bonds and undertakings, recognizances, contracts of indemnity and other writings obligatory in the nature thereof."

"The signature of any authorized officer and the seal of the Company may be affixed by facsimile or electronic transmission to any Power of Attorney or Certification thereof authorizing the execution and delivery of any bond, undertaking, recognizance, or other suretyship obligations of the Company, and such signature and seal when so used shall have the same force and effect as though manually fixed."

In connection with obligations in favor of the Florida Department of Transportation only, it is agreed that the power and authority hereby given to the Attorney-in-Fact includes any and all consents for the release of retained percentages and/or final estimates on engineering and construction contracts required by the State of Florida Department of Transportation. It is fully understood that consenting to the State of Florida Department of Transportation making payment of the final estimate to the Contractor and/or its assignee, shall not relieve this surety company of any of its obligations under its bond.

In connection with obligations in favor of the Kentucky Department of Highways only, it is agreed that the power and authority hereby given to the Attorney-in-Fact cannot be modified or revoked unless prior written personal notice of such intent has been given to the Commissioner-Department of Highways of the Commonwealth of Kentucky at least thirty (30) days prior to the modification or revocation.

In Witness Whereof, the Companies have caused this instrument to be signed and sealed this 21st day of June, 2022

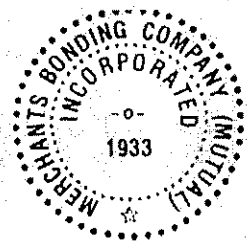
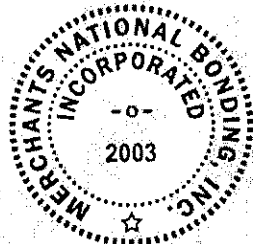

MERCHANTS BONDING COMPANY (MUTUAL)
MERCHANTS NATIONAL BONDING, INC.

By *Larry Taylor*
President

STATE OF IOWA
COUNTY OF DALLAS ss.

On this 21st day of June, 2022, before me appeared Larry Taylor, to me personally known, who being by me duly sworn did say that he is President of MERCHANTS BONDING COMPANY (MUTUAL) and MERCHANTS NATIONAL BONDING, INC.; and that the seals affixed to the foregoing instrument are the Corporate Seals of the Companies; and that the said instrument was signed and sealed in behalf of the Companies by authority of their respective Boards of Directors.



POLLY MASON
Commission Number 750576
My Commission Expires
January 07, 2023

Polly Mason
Notary Public

(Expiration of notary's commission does not invalidate this instrument)

Locker Rooms

OWNER: (Name and address)
Hazel Park Schools
1620 E. Elza
Hazel Park, Michigan 48030

ARCHITECT: (Name and address)
Kingscott
259 East Michigan Avenue, Suite 308
Kalamazoo, Michigan 49007

CONTRACTOR: (Name and address)
Bernco, Inc.
20816 11 Mile Road, Suite 202
St. Clair Shore, MI 48081

THE CONTRACT IS CHANGED AS FOLLOWS:

(Insert a detailed description of the change and, if applicable, attach or reference specific exhibits. Also include agreed upon adjustments attributable to executed Construction Change Directives.)

Item #1:

Demo existing wall and frame new wall between Closet #113 and Change Room #108 per RFI #12.

Demo: \$ 1,431.00
Carpentry: \$ 950.00
Fee: \$ 357.00
Bond: \$ 68.00

Total: \$2,806.00

The original Contract Sum was	\$	<u>543,000.00</u>
The net change by previously authorized Change Orders	\$	<u>47,006.00</u>
The Contract Sum prior to this Change Order was	\$	<u>590,006.00</u> ✓
The Contract Sum will be increased by this Change Order in the amount of	\$	<u>2,806.00</u>
The new Contract Sum including this Change Order will be	\$	<u>592,812.00</u> ✓

The Contract Time will be increased by Zero (0) days.
The new date of Substantial Completion will be

NOTE: This Change Order does not include adjustments to the Contract Sum or Guaranteed Maximum Price, or the Contract Time, that have been authorized by Construction Change Directive until the cost and time have been agreed upon by both the Owner and Contractor, in which case a Change Order is executed to supersede the Construction Change Directive.

NOT VALID UNTIL SIGNED BY THE ARCHITECT, CONTRACTOR AND OWNER.

Kingscott
ARCHITECT (Firm name)

Bernco, Inc.
CONTRACTOR (Firm name)

Hazel Park Schools
OWNER (Firm name)

Re: HAZEL PARK SCHOOLS - HIGH SCHOOL
LOCKER ROOM REMODELING
Bernco, Inc. Project Number 2022.004

Dear TJ,

Below please find our price to supply labor and materials required to install #QH47 Cove Base, matching the wall accent tile, in lieu of originally specified built up base.

Ceramic Tile:	\$5,177.00
Fee:	\$ 777.00
Bond:	\$ 149.00
Total:	\$6,103.00

The cost associated with the work described above maybe adjusted if approval is not received with ten (10) working dates.

We are prepared to proceed with the work described above with your written change order. Should you have questions regarding the above, please call.

Sincerely,
Bernco, Inc.



Tony Cattivera
Project Manager

Cc: B. Cattivera, C. Ferguson

Re: HAZEL PARK SCHOOLS - HIGH SCHOOL
LOCKER ROOM REMODELING
Bernco, Inc. Project Number 2022.004

Dear TJ,

Below please find our price to supply labor and materials required to complete the work described in Proposal Request #1:

Demolition:	\$-1,904.00
Flooring:	\$ 3,950.00
Fee:	\$ 307.00
Bond:	\$ 59.00
Total:	\$ 2,412.00

The cost associated with the work described above maybe adjusted if approval is not received with ten (10) working dates.

We are prepared to proceed with the work described above with your written change order. Should you have questions regarding the above, please call.

Sincerely,
Bernco, Inc.

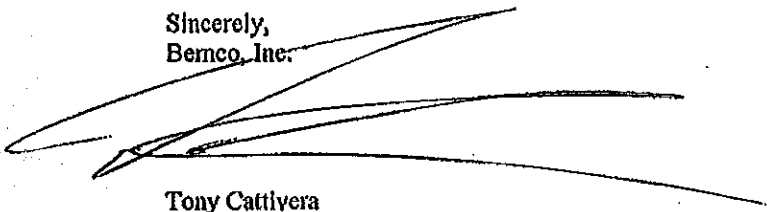

Tony Cattivera
Project Manager

Cc: B. Cattivera, C. Ferguson

Re: HAZEL PARK SCHOOLS - HIGH SCHOOL
LOCKER ROOM REMODELING
Bernco, Inc. Project Number 2022.004

Dear TJ,

Below please find our price to supply labor and materials required to seal existing duct per SOM mechanical inspector:

HVAC:	\$1,022.00
Fee:	\$ 153.00
Bond:	\$ 30.00
Total:	\$1,205.00

The cost associated with the work described above maybe adjusted if approval is not received with ten (10) working dates.

We are prepared to proceed with the work described above with your written change order. Should you have questions regarding the above, please call.

Sincerely,
Bernco, Inc.

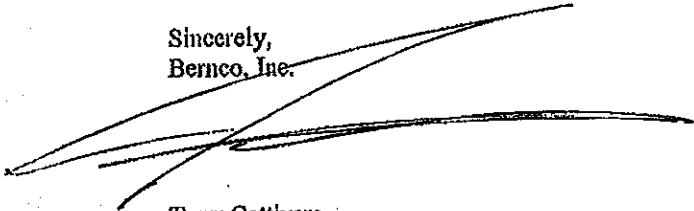

Tony Cattivera
Project Manager

Cc: B. Cattivera, C. Ferguson

Re: HAZEL PARK SCHOOLS - HIGH SCHOOL
LOCKER ROOM REMODELING
Berneo, Inc. Project Number 2022.004

Dear TJ,

Below please find our price to supply labor and materials required to:

Item #1: Per the SOM Plumbing Inspector, insulate existing hot and cold waterlines where asbestos insulation was removed and add hangers at the existing waterlines in locker room.

Mechanical:	\$11,182.00
Fee:	\$ 1,677.00
Bond:	\$ 322.00
Total:	\$13,181.00

Item #2: Per the SOM Plumbing Inspector, insulate existing hot and cold waterlines where asbestos insulation was removed in basement.

Mechanical:	\$14,324.00
Fee:	\$ 2,149.00
Bond:	\$ 412.00
Total:	\$16,885.00

The cost associated with the work described above maybe adjusted if approval is not received with ten (10) working dates.

We are prepared to proceed with the work described above with your written change order. Should you have questions regarding the above, please call.

Sincerely,
Berneo, Inc.

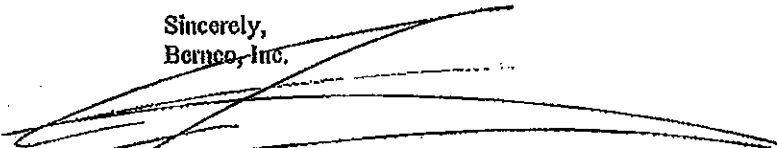

Re: HAZEL PARK SCHOOLS - HIGH SCHOOL,
LOCKER ROOM REMODELING
Bernco, Inc. Project Number 2022.004

Dear TJ,

Below please find our price to supply labor and materials required to:

Item #1: Complete the work described in Proposal Request #2 dated 10/04/2022.

Flooring:	\$6,125.00
Fee:	\$ 919.00
Bond:	\$ 176.00
Total:	\$7,220.00

The cost associated with the work described above maybe adjusted if approval is not received with ten (10) working dates.

We are prepared to proceed with the work described above with your written change order. Should you have questions regarding the above, please call.

Sincerely,
Bernco, Inc.

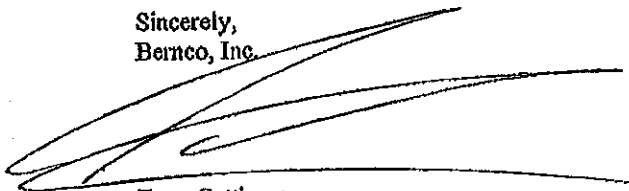

Tony Cattivera
Project Manager

Cc: B. Cattivera, C. Ferguson

Re: HAZEL PARK SCHOOLS - HIGH SCHOOL
LOCKER ROOM REMODELING
Bernco, Inc. Project Number 2022.004

Dear TJ,

Below please find our price to supply labor and materials required to:

Item #1: Demo existing wall and frame new wall between Closet #113 and Change Room #108 per RFI #12.

Demo:	\$1,431.00
Carpentry:	\$ 950.00
Fee:	\$ 357.00
Bond:	\$ 68.00
Total:	\$2,806.00

The cost associated with the work described above maybe adjusted if approval is not received with ten (10) working dates.

We are prepared to proceed with the work described above with your written change order. Should you have questions regarding the above, please call.

Sincerely,
Bernco, Inc

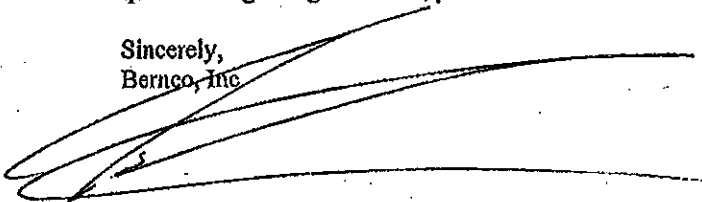

Tony Cattivera
Project Manager

Cc: B. Cattivera, C. Ferguson

1620 East Elza
Hazel Park, MI 48030

Hazel Park, MI 48030

EME Job #	P.O. #	Terms	Date
22-342		Net 30	08/30/2022

Description

Mobilize to site and prep work area as required including engineering controls. Remove exposed asbestos pipe insulation in the men's and women's pool locker rooms at the above referenced location. Work completed August 24, 2022.

Amount

750.00

Subject: Natatorium Locker Room Renovation

Date: April 13, 2022

Bids were opened on Thursday March 8, 2022 for the Natatorium Locker Room Renovation. 1 bid was received for the upgrades was received as follows,

Vendor	Amount
Bernco, Inc	\$543,000

The Bid was reviewed by Kingscott and they are satisfied it is complete and the quoted cost is reasonable based on the scope of work. In comparison to the estimated cost of the work prior to bidding (\$783,000), the quoted amount is well below the estimate.

Based on the documentation and discussion with Kinscott representatives we are recommending Bernco, INc. to perform the Natatorium Locker Room Renovation work with a 5% construction contingency for a total contract amount of \$570,150

Funding Source: Sinking Fund

Resources: The Hazel Park School District will maximize its resources to assure high quality education by fostering financial stability, preserving and utilizing quality facilities, and integrating state-of-the-art technology.

Recommendation

That the Board of Education approves the spending of \$570,000 for the Natatorium Locker Room Renovation

UV Disinfection



Dulcodes A UV systems are ideal for the photochemical decomposition of combined chlorine (inorganic chloramines) in the treatment of swimming pool water. Chlorine-resistant germs, especially cryptosporidium are reliably inactivated. Special medium pressure UV lamps generate intense polychromatic UV light to reduce the strong odor producing and eye irritating substances. The result is an improved quality of water for healthy and pleasant swimming.

Features

- Flow: up to 4592 gpm
- Large graphical display for displaying the time dependency of the UV sensor signal with trend indication.
- Electronic power supplies with automatic set point control to ensure maximum efficiency at lowest power usage. Estimated 40% savings over conventional magnetic ballast systems.
- 8000 hours lamp warranty
- PLC freely programmable control, e.g. for recirculation pump interlock, flushing or circulation bypass, warning and shutdown procedures
- Remote interface and control with DCM 502 and combined chlorine measurement. Additional warranty offered when utilized with ProMinent Chemical Controllers
- Minimum space requirement and highest level of installation flexibility due to free choice of mounting orientation
- Maintenance-friendly, single-end lamp connection and service access allows lamp to be changed out in 5 minutes.

Benefits

- NSF50 listed to NEW 2012 standard
- Only UV systems on NSF site with electronic ballasts
- The A units can save up to 40% power versus a standard magnetic ballast. Which makes power consumption closer to a Low Pressure system
- Electronic ballasts can increase lamp life!
- The A plants are the only UV system on market with Tru-View viewing disc on chamber allowing viewing of UV lamp in operation
- The A plants have PLC based controls with color coded screens that give immediate notice of operation status of system
- The A unit utilizes multiple control points thus allowing for a disinfection setpoint and a chloramine setpoint. Thus the DCM502 will run at lower power for Crypto and ramp up to chloramine control as water chemistry dictates
- 400 days of data logging

1X2A	7781582	1	2000	765	510	6"	1	208/240	12/10	68/128	135	69.7"x38.2"x19.7"
1X3A	7781583	1	3000	1531		8"	3	208/240	13	115/260	135	69.7"x38.2"x19.7"
1X3A	7781584	1	3000	1531	1020	8"	3	208/240	17/15	115/260	135	69.7"x38.2"x19.7"
2X2A	7781585	2	4000	2041	1360	8"	3	480	9	172/366	150	59.8"x40.2"x26.8"
2X2A	7781586	2	4000	2041	1360	8"	3	208/240	20/17	172/366	150	59.8"x40.2"x26.8"
2X3A	7781579	2	6000	3061	2041	10"	3	480	14	172/366	150	59.8"x40.2"x26.8"
2X3A	7781587	2	6000	3061	2041	10"	3	208/240	28/25	172/366	150	59.8"x40.2"x26.8"
3x3A	7781588	3	9000	4592	3061	12"	3	480	14	172/366	205	38.2"x34.3"x60.6"
3x3A	7781589	3	9000	4592	3061	12"	3	208/240	28/25	172/366	205	38.2"x34.3"x60.6"

Note: Additional flange sizes available upon request based on flow range and pipe velocity

Dimensional Drawings & Sizes

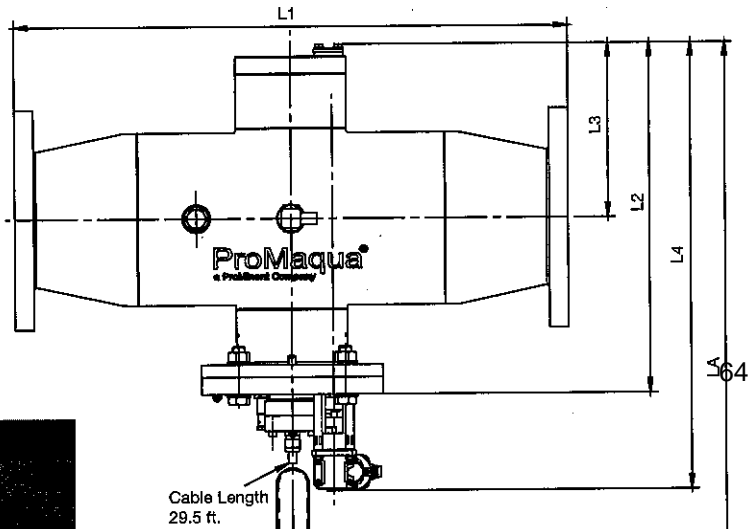
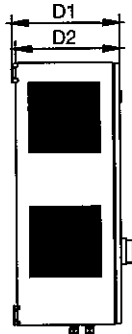
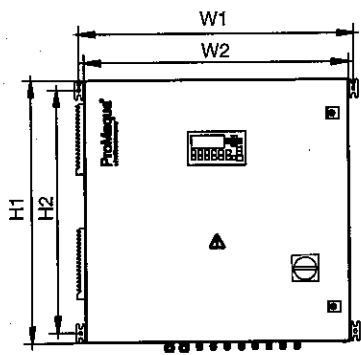

Dimensions											
Model	Chamber					Cabinet					
	L1	L2	L3	L4	LA	H1	H2	W1	W2	D1	D2

1X1A	27.5"	13.7"	6.8"	18.5"	26.1"	29.9"	24.6"	31.1"	29.9"	12.2"	11.8"
------	-------	-------	------	-------	-------	-------	-------	-------	-------	-------	-------

Pool Additions

I have pricing put together for this.

Option for 3 different size scoreboards.

We will have to involve an electrician. I have a \$10,000 allowance included for that currently.

Let m know your thoughts on this and I will put it on a formal request for change order.

Provide and install in deck timing system by Colorado Timing Systems :

(1) - Gen7 Timing console

(7) - Touchpads

(1) - Start system with pole mount

(6) - Titanium deck plates

(2) - wall plates

(2) - digital pace clocks

Core drilling of deck and tile patches for new deck plates

Installation and training

Total for timing system = \$62,192 (this includes \$10,000 allowance for an electrician to rough for new scoreboard)

Scoreboards

Option #1 – 7.4' H x 12.6' W = **\$68,437**

and functionality of your facility.



Deck plates are required to permit plug-in connections for touchpads, A/B/C backup pushbuttons, electronic relay judging, start speakers, and a signal to start the timing device at each lane.

This rugged in-deck solution features:

Titanium jacks

- Corrosion free from pool water chemicals like chlorines and bromines

Unique domed topography

- Protects banana plugs
- Peaks and valleys let the water flow off, dramatically limiting corrosion through electrolysis
- Better signal, less corrosion
- Smooth edges
- Will not yellow in the sun

Integrated speedlight connection

- No speedlight harness necessary
- Robust plug combining speedlight and relay judging signal

Warranty

- 5-year warranty

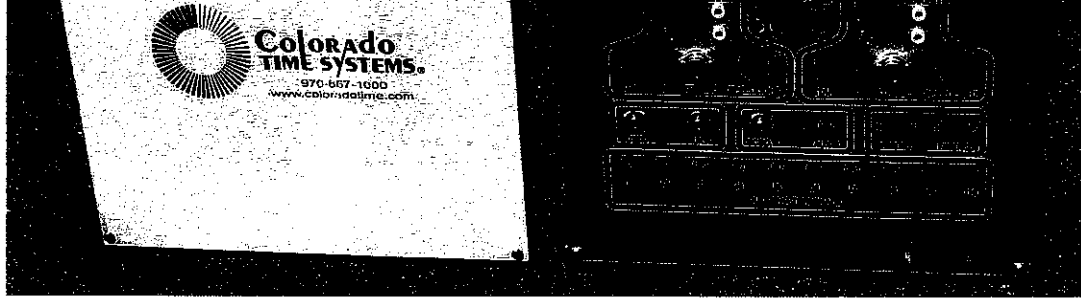

This universal wall plate can be set up in any number of configurations, and includes options for LED matrix display fiber, judging terminals, long- and short-course configurations and can accommodate up to 12 lanes. Blank wall plates are also available for future expansion (above left).

Options include:

Basic timing - near end (WLPA)

Basic timing - near and far end (WLPA-F)

Basic timing - near end and short course (WLPA-S)

Basic timing - near end, far end, and short course (WLPA-FS)

Diving option (K-DV)

12-lane option (K-12)

Wallplates are standard 15" x 15" x .25" (38.1 cm x 38.1 cm x .64cm) aluminum panels. All wiring and terminal connections are included.

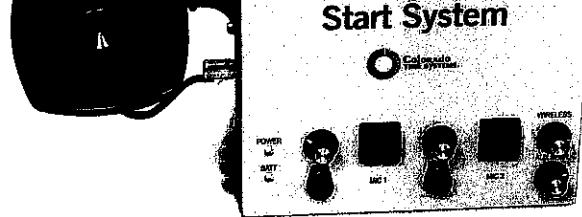

Rugged durability and long lasting performance.

The Championship Start System allows you design a customized start solution for your pool. It can drive speakers mounted under the starting blocks, and is the only start system that will drive the Relay Judging Platform speedlights and deckside start indicators, which are synchronized with the start horn and strobe. Each Championship Start System includes a wired microphone.

Features:

- **Relay Judging Platform speedlights:** The Championship Start System is the only start system that will drive the speedlights and deckside start indicators on the Relay Judging Platforms.
- **Microphones:** Three separate microphone inputs; two wired and one optional wireless microphone, with independent volume control for each microphone input. The microphone volume is independent of start tone volume.
- **External 360 ° strobe:** Flashes with start signal tone. Additional strobe lights for other locations available.
- **Battery or 110/240V power:** Use in a fixed location with 110/240VAC , or as a portable system with battery power. An LED low battery indicator provides an early alert that the battery level is getting low.
- **Public address system:** The Championship Start System can serve as a limited public address system.

speakers and LEDs are located on the front of a Colorado Time Systems' relay judging platform (RJP) and LEDs at the deckside of the connector blocks that flash simultaneously with the Championship Start speaker tone and strobe light. The Championship Start can drive speedlights on the RJP's for up to 12 lanes. Speedlights level the playing field for hearing-impaired athletes. They offer all athletes a visual cue, and experience practicing with the type of start system used at championship competitions.

Strobe light: Bright 360 ° strobe light automatically flashes simultaneously with the audio start signal. This gives watch timers and officials a reliable start reference, and provides a fair start to hearing-impaired athletes.

Power: Runs from normal wall power (110~240VAC) with an included wall connector; or the unit can be powered by two safe and reliable internal gel-cell batteries. Batteries will recharge automatically when the unit is plugged in a wall outlet. This unit will operate while charging.

Wired/Wireless microphone: Used to address swimmers, start the race, and recall athletes in the event of a false start.

Speakers: 10-watt/8-ohm moisture and corrosion resistant compression speaker is used as AUX speaker. Up to two speakers can be connected to the AUX speaker output.

6-watt/45-ohm moisture and corrosion resistant reflex speaker used as a lane speaker. The Championship Start System can drive up to 12 lane speakers.

Underwater speaker for underwater recall and training options

- Wireless Championship Start System
- 10-watt/8-ohm black auxiliary speaker
- Microphone with 25-ft cable
- Wireless microphone with transmitter

Optional equipment

- Portable tripod; disassembles easily for compact storage -- adjustable height
- Jumper cable
- Microphone
- 10-watt/8-ohm black auxiliary speaker
- 6-watt/45-ohm lane speaker
- Underwater speaker
- Loudspeaker cable harness
- External strobe and cable
- Wall mounting kit
- Speaker mounting kit
- Championship Start to wall plate cable
- Additional wireless microphone kit: wireless microphone, transmitter, receiver module, and receiver cable

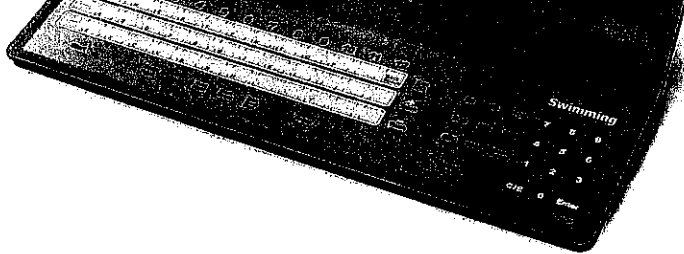

The System 6 Timing Console is used worldwide at Championship meets including FINA and NCAA Championships.

The System 6 is your central timing console and coordinates incoming and outgoing information from the key components of your complete timing system. System 6 is a standalone unit dedicated solely to timing and scoring, which improves your ability to run an event with confidence.

Swimming and diving software programs come standard with each system. Water Polo and pace clock software are also available. You can switch between sports by utilizing the keyboard inserts provided with each additional software package.

72

FINA Diving Grand Prix | National Winter Swim Championships - China Swimming Association
SEA Games | FINA World Cup | NCAA Swimming & Diving Championships
European Junior Swimming Championships | National China Spring Championships
South African Games | Commonwealth Games | South American Games



both near-and far-end.

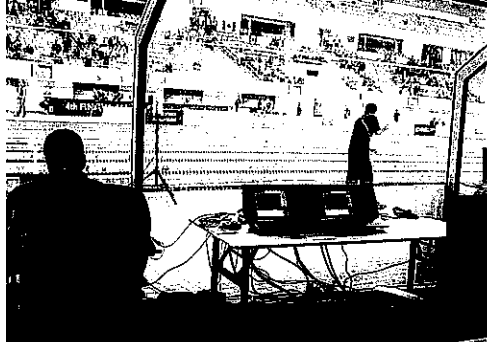

Expanded lane capability

The System 6 is the only timing console on the market that can support up to 12 lanes. The System 6 is engineered for flexibility in lane shifting and lane reversal. This allows you, for example, to shift your race course to the center lanes of the pool; yet keep the lane numbering standard.

Meet management

The System 6 is compatible with most meet management programs available.

Rechargeable battery

The System 6 includes a rechargeable battery for backup in case of an emergency power outage.

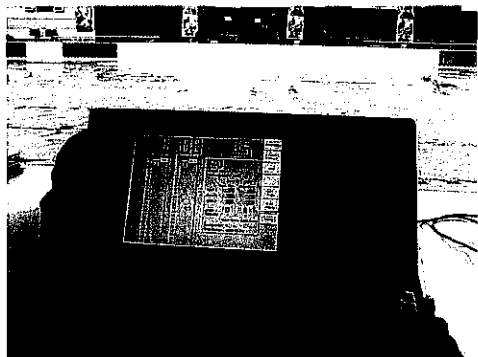

Product Specifications:

Product safety approval: UL Certification

Dimensions (H x W x D): 9.75" x 18.38" x 11.5" (24.8cm x 46.7cm x 29.2cm)

Weight: 10 lbs (4.5kg)

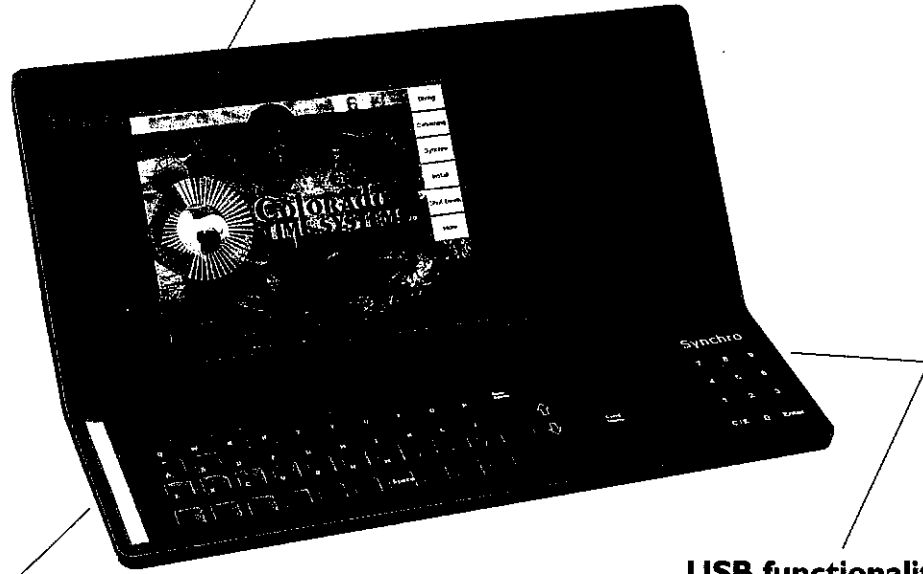

Multi-sport options

Swimming and diving are standard with the System 6; optional changeable keyboard inserts and software programs are available for water polo and training pace clock

USB functionality

Support of PCL printers (USB or parallel), memory stick for 74 data transfer, keyboard and mouse support.

The System 6 has a built-in feature to control the intensity of the LED numeric scoreboards and pace clocks. This is beneficial when using a facility for both day and night events, as well as indoor & outdoor events.

Intelligent button handling

The System 6 will apply the ruling governing bodies rules to backup buttons on a per lane basis. The appropriate rule will be used to generate the backup time based on the number of buttons that are received for a lane.

Relay judging

The System 6 has improved relay judging in swimming. The window of time surrounding the touchpad hit is alterable during set up. This lets you constrain the amount of time the System 6 is looking for an RJP impulse, thus avoiding external influences such as athletes hitting the blocks or stretching on them.

Start reaction

The System 6 will measure the time difference between the start signal and the impulse from the RJP or the touchpad (backstroke starts). When the start reaction time is enabled, the System 6 will post the start reaction time to the scoreboard.

Declare start/finish end

You can tell the System 6 where odd and even length races will start, which determines where they will finish. This way, you can start a 50m race at the far end and finish at the near end (odd length race). The even length races would be set to start at the near end and finish at the near end.

Automatic backup time adjustment

You have the option to automatically adjust the backup time for a lane with a discrepancy. If backup adjustment time is turned on, the System 6 will calculate the average differential across all good lanes and factor that into the backup time.

Dynamic sponsor message

Load your own sponsor message and it will appear at the top of each results page print out.

Lane re-arming

The System 6 will automatically turn on any lanes that are listed as lanes used in a pool after a Reset. This way, there is no chance of leaving a lane off when a swimmer is in the next heat.

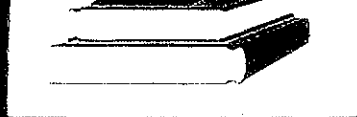

1/18/2014

The System 6 Pace Clock software allows you to program workouts, which can be displayed on your scoreboard and/or printed out on paper.

The pace clock option can be used to program up to twelve lanes of individual workouts, 100 independent sets per lane, and can calculate the total workout time. You can personalize each workout by adding each swimmer's name. Workouts can be entered in a PC workout program for download to the System6, then uploaded back to the PC for unlimited storage of workout sets. You can also have the ability to monitor the current workout plus the next two sets on the System 6 screen.

The System 6 memory allows you to design your entire training regimen at the beginning of the season and build routines as your swimmers progress. Each workout can be recalled from memory for use at any time.

The pace clock program makes it easy to control each workout independently. Then, you can print the workouts for a permanent record by individual lane or for all lanes.



900MHz wireless adapter (WA-1)



2.4Ghz wireless adapter (WA-2)

Convert to wireless communication.

Wireless scoreboard adapters allow you to wireless transmit data to Colorado Time Systems' LED scoreboards. Whether you are running swimming, diving, synchronized swimming, or water polo, this adapter can work for you.

Simply connect one wireless adapter to your timing console, and the other to the device that you wish to transmit data to (LED scoreboard, pace clocks, etc).

- Eliminate scoreboard data cables
- Transmit data from your timing console to:
 - Digital pace clocks
 - Digital shot clocks
 - Single- & multi-line LED scoreboards
 - LED matrix displays

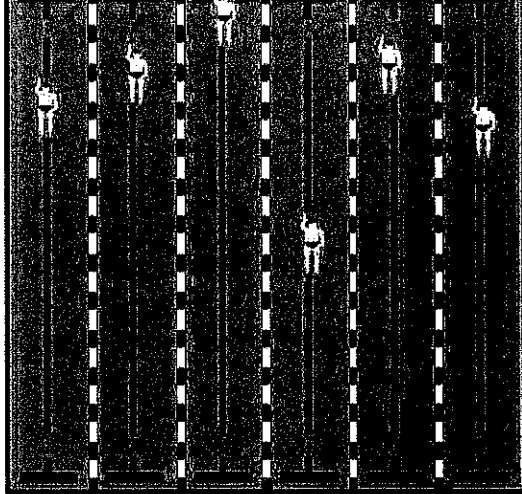

Infinity Start System

Championship Timing System

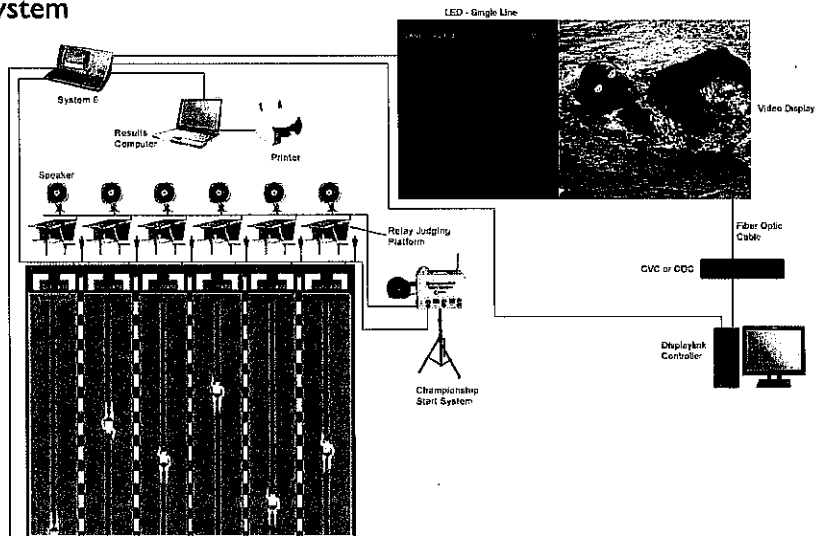



Colorado Time Systems provides a full line of accurate and reliable aquatic timing and scoring products including:

- Touchpads
- Relay judging platforms
- Timing consoles
- Start systems
- Judging terminals for diving and synchronized swimming
- Water polo shot clocks
- Training products for start reaction and break-out time, speed training, and relay exchanges
- Pace clocks
- Numeric LED scoreboards
- LED matrix single- or full-color displays

We look forward to providing you with the finest aquatic timing and meet hardware products in the world. With an extensive background in aquatic sports, we have been fulfilling aquatic timing and scoring needs for over four decades.

From our inception, Colorado Time Systems has set the standard for timing technology and fairness in aquatic competition. Today, we are the leading provider of sports timing and scoring systems with over 20,000 installations in more than 120 countries.

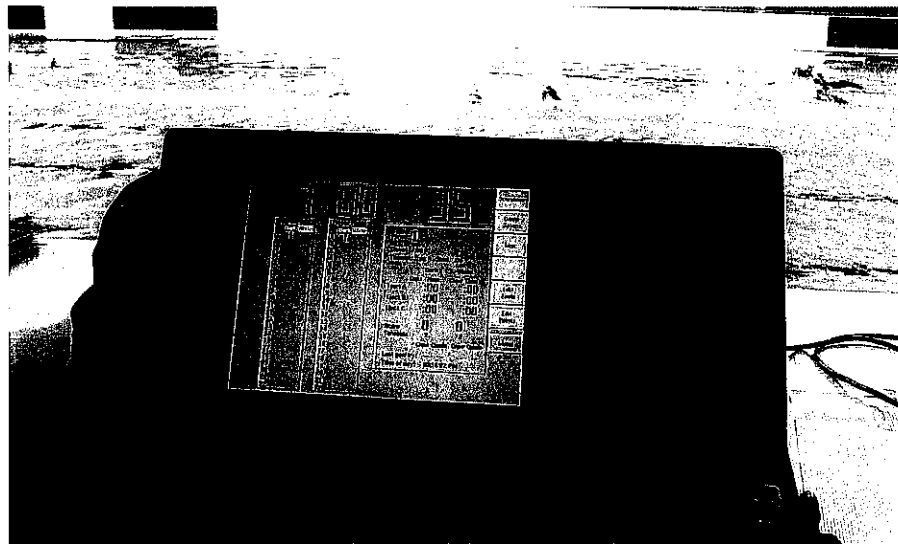



Simplify your diving and synchronized swimming meets for your judges, console operator, and volunteers.

Easy to set up: No more cables running on the deck. Simply connect the Wireless Interface Box to your System 5 or System 6 timing console and assign judge numbers to each Wireless Judging Terminal (WJT).

Easy to use: Each judge enters his or her score on the WJT when prompted by the timing console. The WJT transmits the scores for each judge to the timing console, and the timing console then calculates the score.

Efficient: You can run multiple events in the same vicinity or even in the same facility. 2.4GHz wireless technology offers twelve (12) wireless channels to allow adjustment for potential interference and make simultaneous events possible. The system supports up to 99 judging terminals plus one referee's terminal.

The WJTs have been designed specifically for the aquatic environment, weigh just over a pound, and are packed with these useful features:

- Easy to enter scores
- One button press to view remaining battery life
- Runs on 4 "AA" batteries, with a battery life of 16 hours (batteries are not included)
- Backlighting and contrast on the 4-line display can be adjusted to individual judge's preference and facility conditions.

Dimensions (L x W x H): 7.5" x 5" x 2" (19cm x 12.7cm x 5cm)

Weight: 17.2 oz (487g)



Get a grip on every start and turn!

The AquaGrip® touchpads combine the best starting and turning surface available with the proven design that all Colorado Time Systems' touchpads have used for over forty years. They respond to a touch that's remarkably light - but provide a push-off that's thoroughly firm. AquaGrip® touchpads feature all-plastic construction that is tough and durable; yet their textured, non-skid surface is gentle on swimmers' hands and feet. The solid quarter inch plastic backbone, molded one-piece connectors and non-corrosive finish provide long-lasting reliability.

Easy to install, stays in place

Set-up is easy, thanks to our universal mounting system customized for your pool. They hold your pads in place without hardware or holes (in most pools) and prevent unwanted vertical and lateral movement. Best of all, you don't need any tools. Our touchpads can be left in the water for the duration of a meet.

Sensitive to the lightest touch

Dependable, internally sealed switches record even the lightest swimmers' touch on the fully active face of all CTS pads, and also along the top edge of gutter-mounted pads. You get an accurate finish every time with no "dead spots."

A perfect size for every lane

At Colorado Time Systems, we will help you select the right touchpad for your facility. Choose from standard-sized flat- or gutter-mount pads. Custom widths are also available.

	Gutterhung		Flatwall*	
188.5cm x 90cm FINA touchpad	TP-188.5G	47 lbs (21.3kg)	TP-188.5GF	47 lbs (21.3kg)
195cm x 90cm FINA touchpad	TP-195G	49 lbs (22.2kg)	TP-195GF	49 lbs (22.2kg)
240cm x 90cm FINA touchpad	TP-240G	66 lbs (30kg)	TP-240GF	66 lbs (30kg)
60" x 22" touchpad (152.4cm x 55.88cm) Recommended for lanes 66 - 84" wide	TP-60G	28 lbs (12.7kg)		
60" x 24" touchpad (152.4cm x 60.96cm) Recommended for lanes 66 - 88" wide			TP-60GF	33 lbs (15kg)
78" x 22" touchpad (198.12cm x 55.88cm) Recommended for lanes 84 - 96" wide	TP-78G	35 lbs (15.9kg)		
78" x 24" touchpad (198.12cm x 60.96cm) Recommended for lanes 84 - 96" wide			TP-78GF	40 lbs (18.1kg)
96" x 22" touchpad (243.84cm x 55.88cm)	TP-96G	45 lbs (20.4kg)		

All touchpads have a thickness of ~.76cm +/- (~.30" +/-)

*Flatwall touchpads are 3" (7.6cm) wider than gutterhung touchpads. All specifications are subject to change without notice.

Accessories:

TPM-D: Touchpad test meter. Meter shows touchpad open and closed circuit status. Meter also tests pushbuttons, data cable, deck plates, and scoreboard.

CAD-TP/P: Storage caddy that holds up to ten touchpads. Aluminum construction and four casters allow for easy transportation.

CAD-TP/FINA: Storage caddy for FINA touchpads; each caddy holds up to ten touchpads. Aluminum construction and

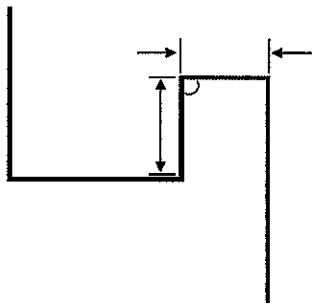

Diagram 1

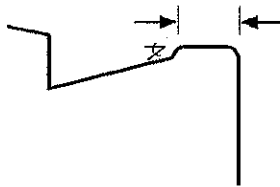

Diagram 2

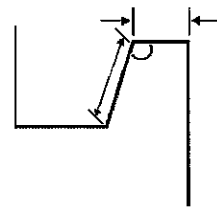

Diagram 3

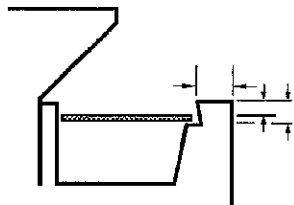

Diagram 4

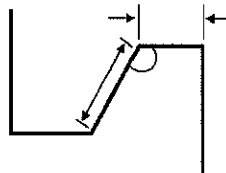

Diagram 5

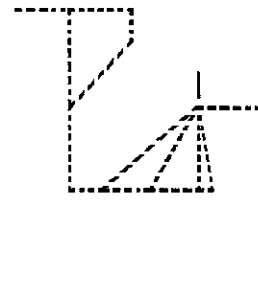
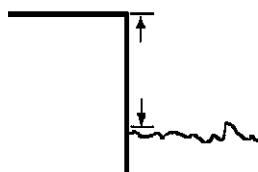
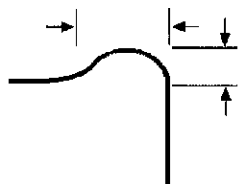

Diagram 6





Protect your touchpad investment.

Our touchpad caddy provides safe storage and a convenient means to transport your touchpads to the pool deck. Each touchpad caddy accommodates up to ten (10) touchpads.

Specifications for gutterhung touchpad caddies

Gutterhung touchpad caddies feature an aluminum frame construction and four free wheeling casters.

CAD-TP/P

Partially assembled version for touchpads up to 78" wide

Dimensions (L x H x W): 82" x 47" x 22" (208.3cm x 119.4cm x 55.9cm)

Weight: 105 lbs (47.6kg)

CAD-TP96

For 96" touchpads

Dimensions (L x H x W): 102" x 47" x 22" (259.1cm x 119.4cm x 55.9cm)

Weight: 150 lbs (68kg)

CAD-TP/FINA

For FINA touchpads

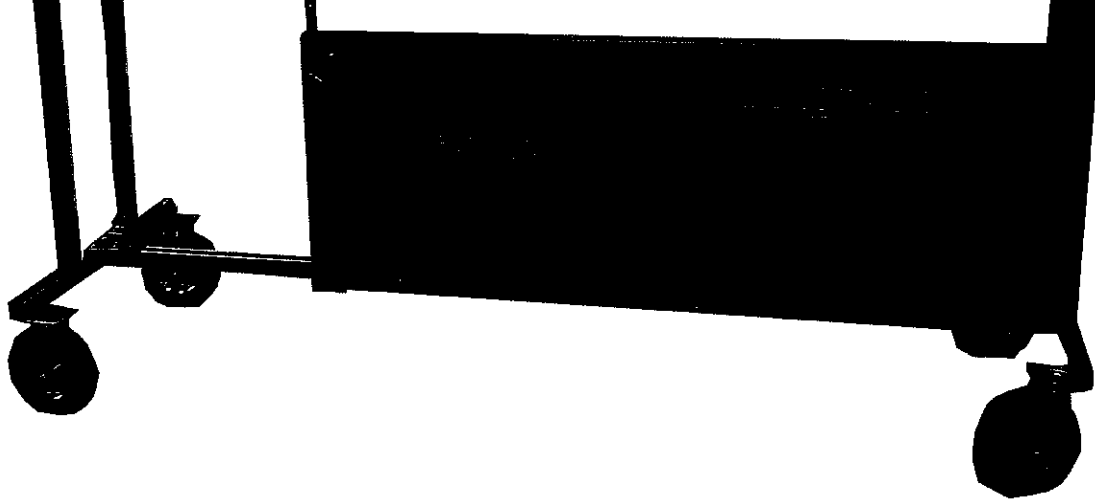

CAD-TP78FA

Dimensions (L X H x W): 104" x 45.25" x 30" (264.2cm x 114.9cm x 76.2cm)

Weight: 175 lbs (79.3kg)

CAD-TP60FA

Dimensions (L x H x W): 90" x 45.25" x 30" (228.6cm x 114.9cm x 76.2cm)

Weight: 153 lbs (69.3kg)

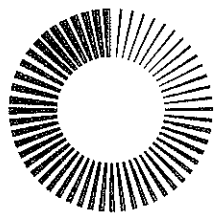

**Colorado
TIME SYSTEMS**
A PLAYCORE Company

LED VIDEO DISPLAYS

High Impact Visuals. Dynamic Technology.



your athletes, coaches, and fans with an exceptional event. We look forward to making your vision a reality with a superior display that combines both form and function to bring you consistent, reliable performance, and an effortless experience.

Enhance. Engage. Enjoy.

Video displays are capable of displaying text, scoring data, animations, live video, video replays, and more.

Premier athletic venues throughout the world are choosing this dynamic technology to enhance their facility each and every day.

Unique Features

- *Indoor or Outdoor*
- *Modular Design*
- *Conformal Coated*
- *4mm - 12mm SMD (Indoor or Outdoor)*
- *Multiple Video Inputs*
- *DisplayLink+ Software*
- *Versatile Display Controller*

Versatile Display Controller

- Video inputs include (1) DVI, (1) HDMI, (1) 3G-SDI, (1) DP, (1) CVBS, (1) VGA; supporting input resolution up to 1920x1200 @ 60Hz; inputs can be scaled point-to-point according to the video display resolution ⁸⁸
- Seamless high-speed switch and fade-in/fade-out effect
- PIP size and location can be adjusted on the fly
- True color reproduction through implementation of white balance calibration and color gamut mapping based on different features of LEDs used by screens
- Loading capacity of 2.3 million pixels
- All system functions, including video configuration and switching can be accomplished using jog dial and

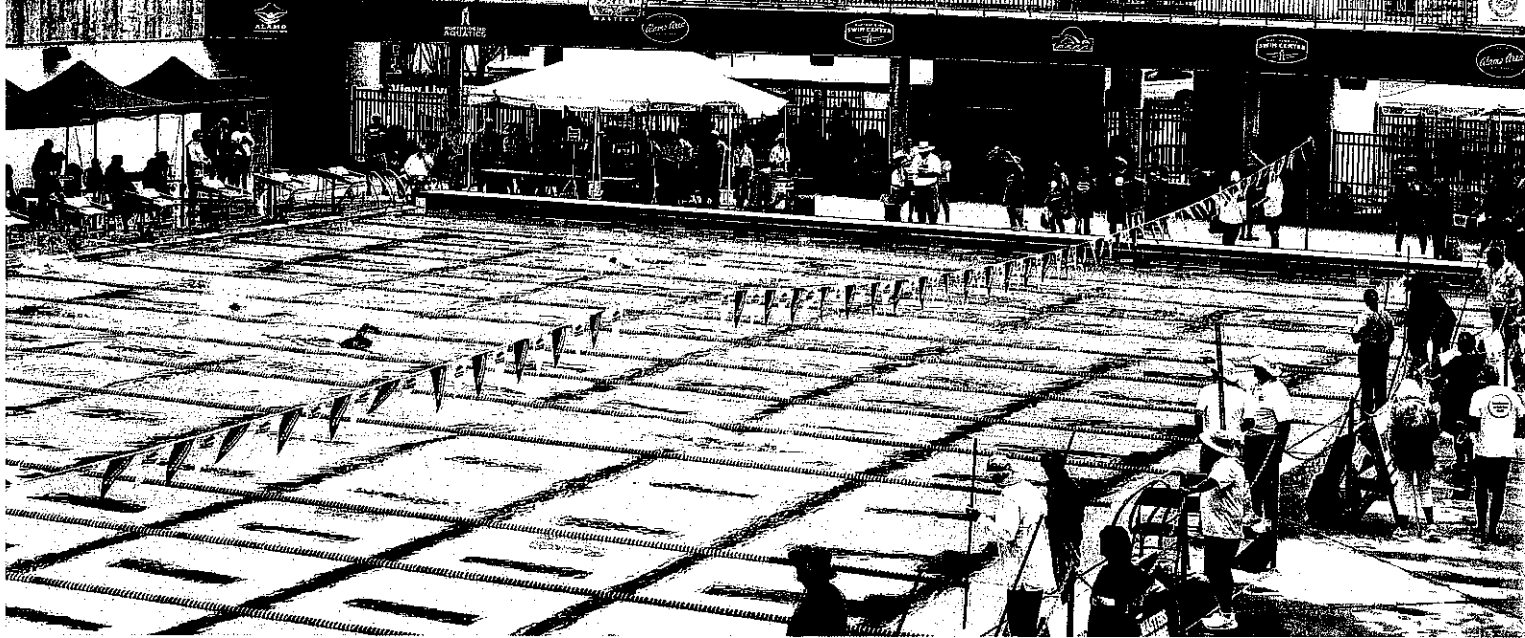

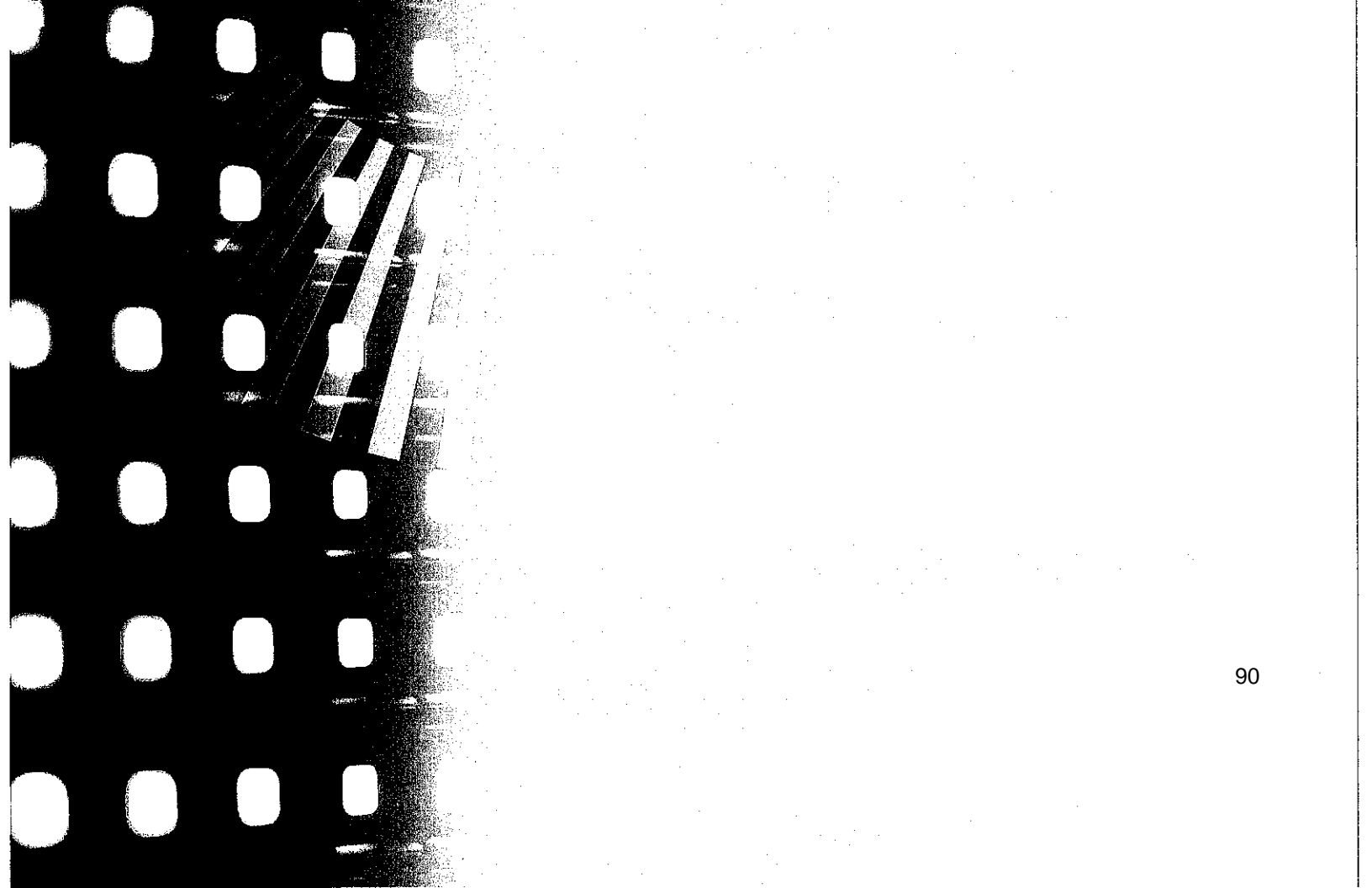

display.

DL+ interfaces with all current CTS timing equipment and many third party meet management software packages. DL+ supports most sports.

The computer provided with your LED matrix display comes pre-loaded with the DL+ software, which includes a template editor and sequence editor for easy content creation and management. DL+ supports multiple displays from one computer, and up to four CTS timing consoles or multisport tabletop controllers.

Key Features

- **Drag & Drop Animations and Graphics:** Use DL+ to display graphics and animations by dragging the image from the Library over to the Active Display window.
- **Template Overlay:** The template overlay feature allows you to display timing, scoring, and other data on top of a video, animation, or image running in the background.
- **Slide Show Capabilities:** Create your own slide shows with the Sequence Editor and set them to run on a continual loop.
- **Animation with Sound:** DL+ supports the ability

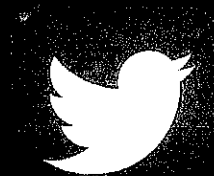

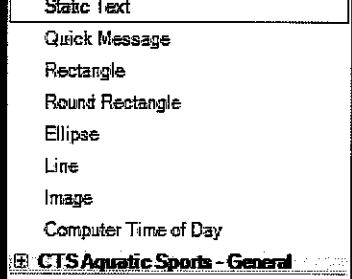
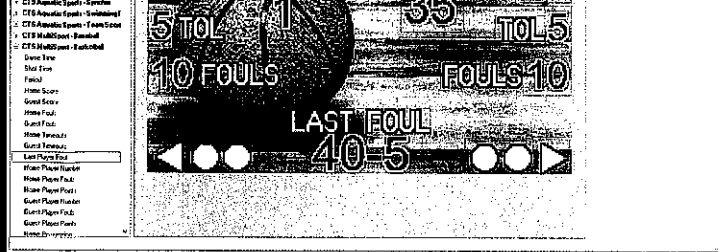

Templates are the DL+ files that tell your display where to place your timing, scoring and meet management information. You can have an unlimited number of templates for every sport. With Template Editor, you can easily create or change a template including positioning of data fields, font variables (color, size, style), and set the background image.

Template Editor allows you to create attractive ways of showing your timing and scoring data.

Editing a template is easy, showing you what the display will look like as you place items on the screen.

Key Features:

- Variable template items depending on sport including:
- Time of day, with seconds (from PC)
- Static text
- Quick messages
- Athlete names and team affiliations
- Data from CTS consoles or controllers including:
- Lane, place, time
- Event and heat data
- Dive descriptions
- Scoring and timing data



Ford Administration
1620 E. Elza, Hazel Park, MI 48030 | 248-658-5200 | F: 248-544-5223
www.hazelparkschools.org

To: Hazel Park Board of Education
From: Amy Kruppe, Superintendent
Jason Zirniss, Assistant Superintendent of Business and Operations
Subject: Concrete and Door Work
Date: 12/8/2022

Funding Source:
General Fund

During the last few weeks Maintenance has identified several doors that need replacing. Instead of replacing the locations with double doors we are recommending placing a single regular door at the Webb location and a large door at Ford to receive pallets into the building. Both of these projects required some concrete and block work for the footing and reduction of the building opening. The concrete contractor, since he was on site, was able to provide a discount to provide other concrete work and several jobs were identified to complete.

Webb Door and concrete block work - \$7,872 (remove existing door and replace door)
Ford Door and block work - \$11,603 (remove existing door and replace door)
Edison sidewalk work - \$5,300 (remove and replace sidewalk with grade to remove snow)

Total cost \$24,775

Strategic Goal Alignment

- Resources: The Hazel Park School District will maximize its resources to assure high quality education by fostering financial stability, preserving and utilizing quality facilities, and integrating state-of-the-art technology.

Recommendation

We are asking the Board to approve the door and concrete work for a total cost of \$24,775.

**APPROVED AND RECOMMENDED FOR
BOARD ACTION**

Amy Y. Kruppe, Ed.D.
Superintendent



Hazel Park School District

Regular Board of
Education Meeting
December 12, 2022



Today's Learners, Tomorrow's Leaders



PBIS/ SEL UPDATE

Fall/Winter 2022

95

Board Presentation: December 12, 2022

PBIS & SEL - DISTRICT LEADERSHIP TEAMS

PBIS DISTRICT TEAM MEMBERS:

- Dr. Michelle Krause, Principal - Edison
- Katherine Byerly, Social Worker-Edison
- Karen Tylenda, Psychologist- Edison
- Debbie Dimas, Principal- Hoover
- Corrie Nastasi, Principal- Webb
- Corrie Chansler, Supervisor of Student Services

SEL DISTRICT TEAM:

- Dr. Amy Kruppe
- Dr. Stephanie Dulmage
- Corrie Chansler
- Dr. Michelle Krause
- Karen Tylenda
- Katherine Byerly



PBIS ACCOMPLISHMENTS - December 2022

- **100 PERCENT** of schools have implemented Tier 1 and Tier 2.
- 100 Percent of schools have a PBIS Coach and designated building leadership team.
- Building coaches meet monthly as a group to discuss roadblocks and problem solve
- Building teams meet at least monthly to review data and identify students needing more intensive interventions.
- We have completed 2 District and 2 Building Data reviews which guide future planning.

School Climate Survey Results Fall 2022

Multi-Year Comparison

Webb Elementary

School Climate Survey: Elementary
-- Total Scores By Survey Date --
School Years: 2019 - 2022

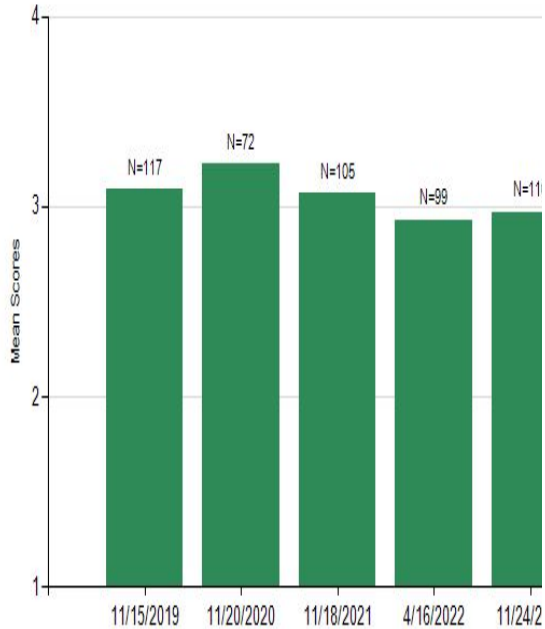

School Climate Survey: Families
-- Total Scores By Survey Date --
School Years: 2019 - 2022

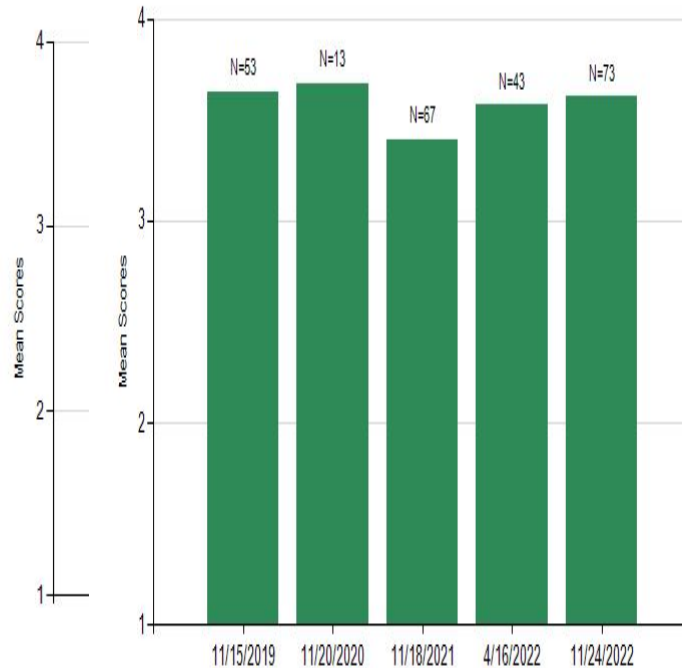

School Climate Survey: School Personnel
-- Total Scores By Survey Date --
School Years: 2019 - 2022

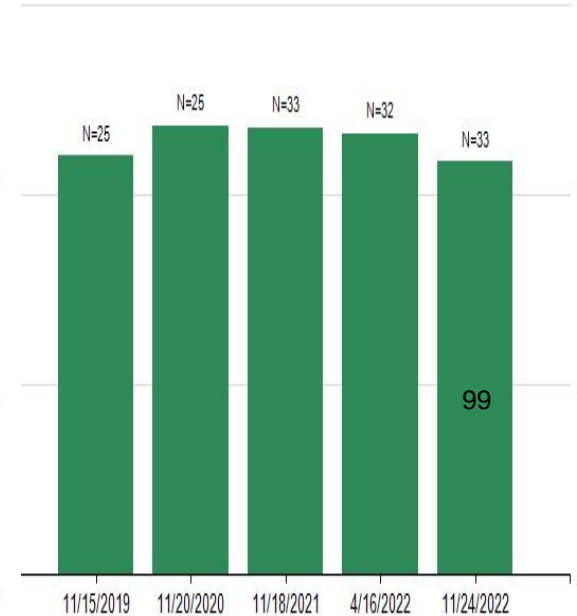

United Oaks Elementary

School Climate Survey: Elementary
-- Total Scores By Survey Date --
School Years: 2019 - 2022

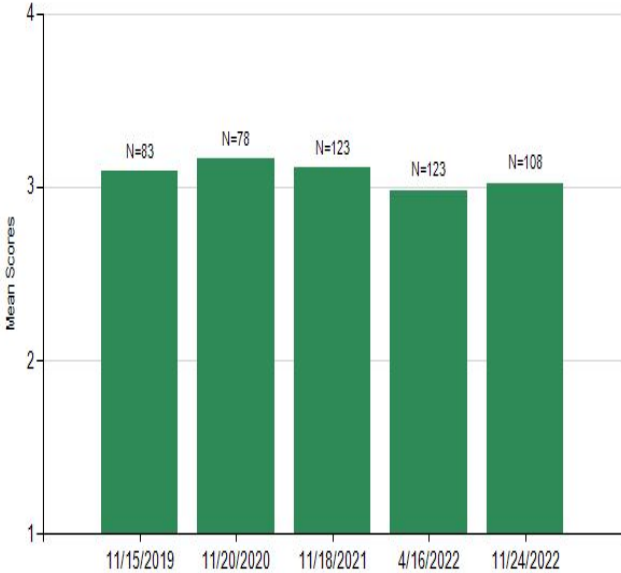

School Climate Survey: Families
-- Total Scores By Survey Date --
School Years: 2019 - 2022

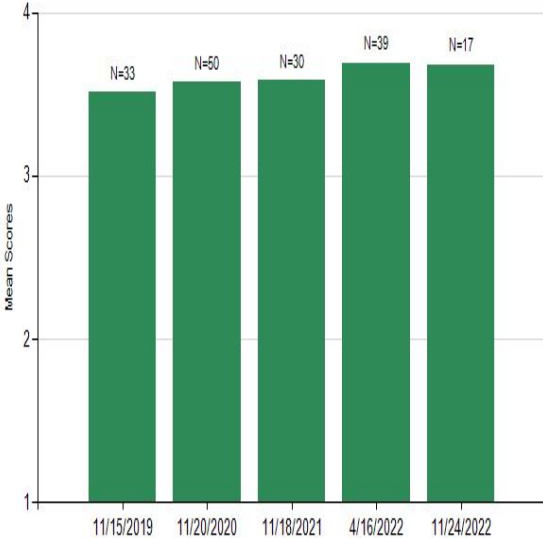

School Climate Survey: School Personnel
-- Total Scores By Survey Date --
School Years: 2019 - 2022

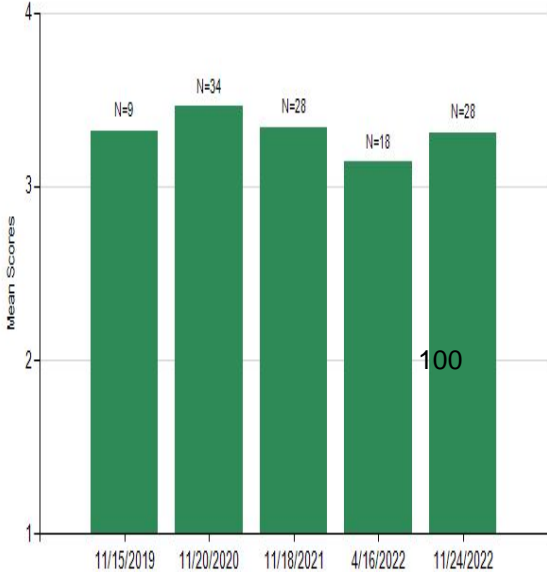

Hoover Elementary

School Climate Survey: Elementary
-- Total Scores By Survey Date --
School Years: 2019 - 2022

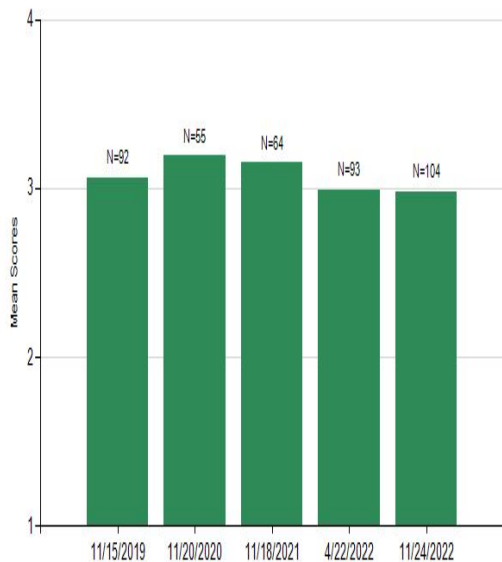

School Climate Survey: Families
-- Total Scores By Survey Date --
School Years: 2019 - 2022

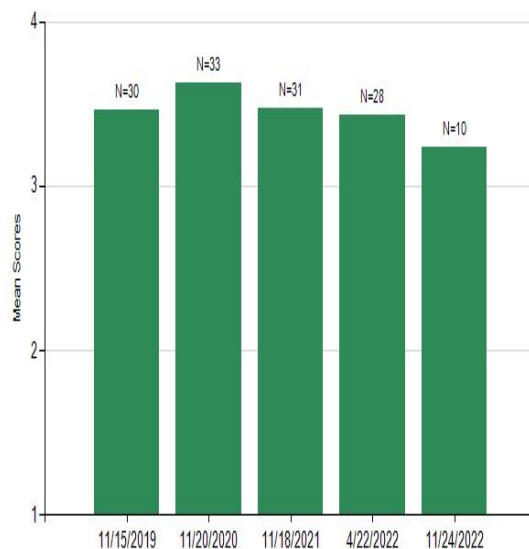

School Climate Survey: School Personnel
-- Total Scores By Survey Date --
School Years: 2019 - 2022

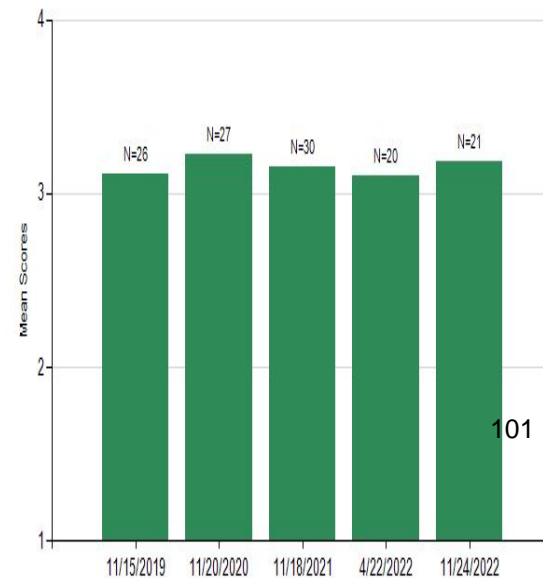

Edison: Middle and High School

School Climate Survey: Secondary (brief version)
-- Total Scores By Survey Date --
School Years: 2019 - 2022

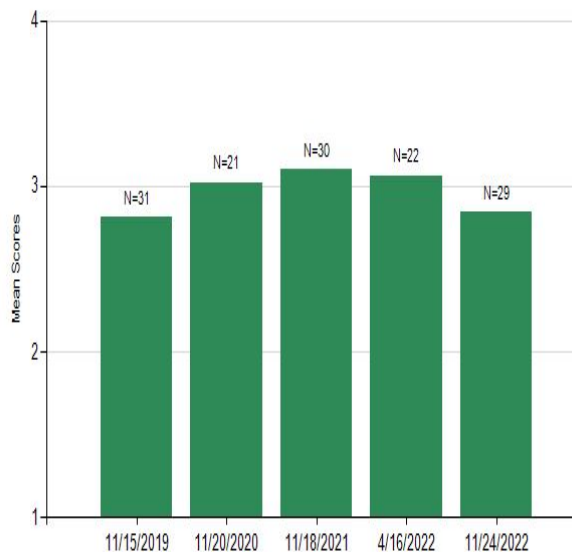

School Climate Survey: Families
-- Total Scores By Survey Date --
School Years: 2019 - 2022

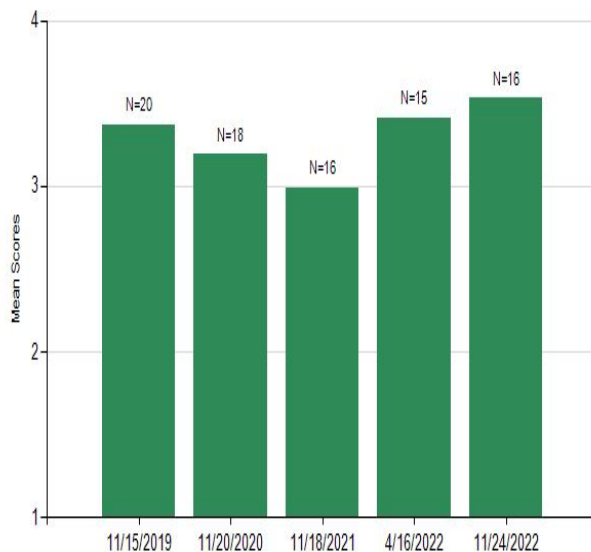

School Climate Survey: School Personnel
-- Total Scores By Survey Date --
School Years: 2019 - 2022

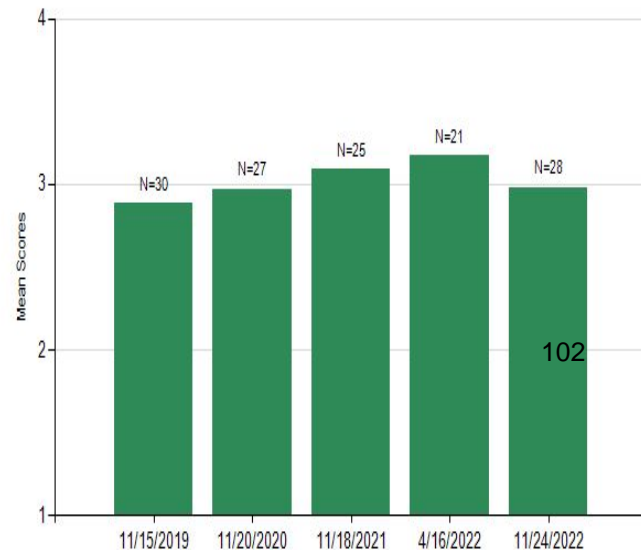

Advantage

School Climate Survey: Secondary (brief version)
– Total Scores By Survey Date –
School Years: 2019 - 2022

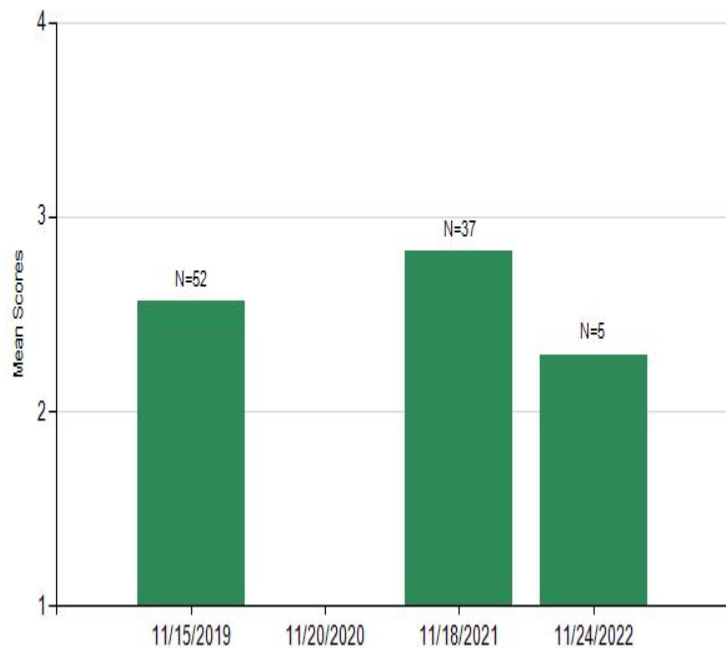

School Climate Survey: School Personnel
– Total Scores By Survey Date –
School Years: 2019 - 2022

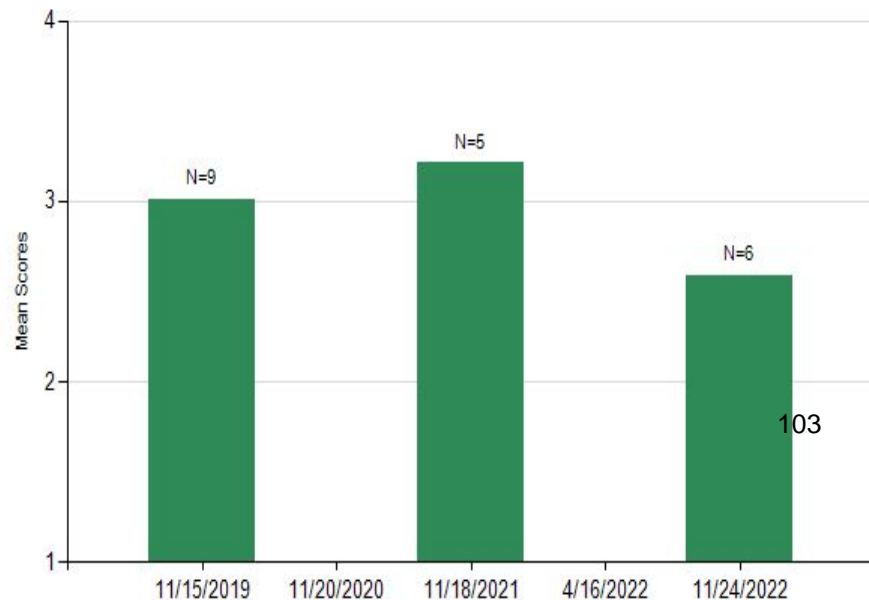

Hazel Park Junior High

School Climate Survey: Secondary (brief version)
- Total Scores By Survey Date -
School Years: 2019 - 2022



School Climate Survey: School Personnel
- Total Scores By Survey Date -
School Years: 2019 - 2022

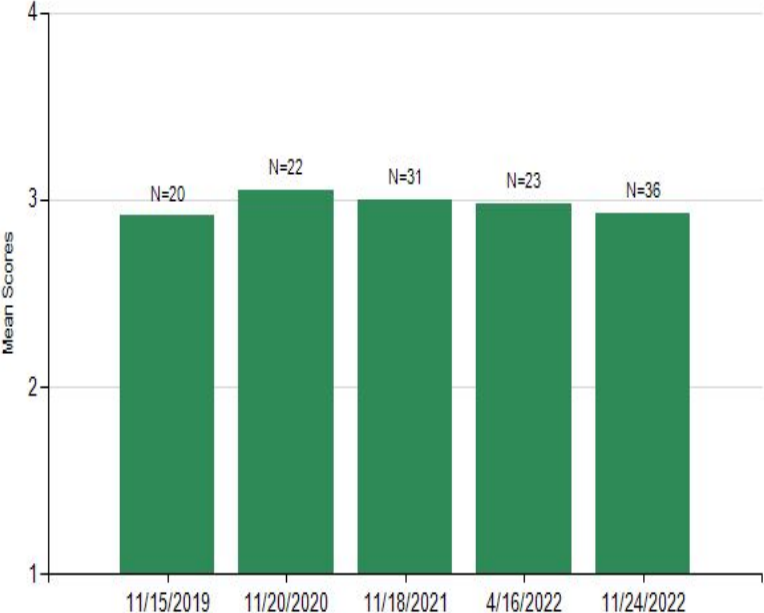

Hazel Park High School

School Climate Survey: Secondary (brief version)
-- Total Scores By Survey Date --
School Years: 2019 - 2022

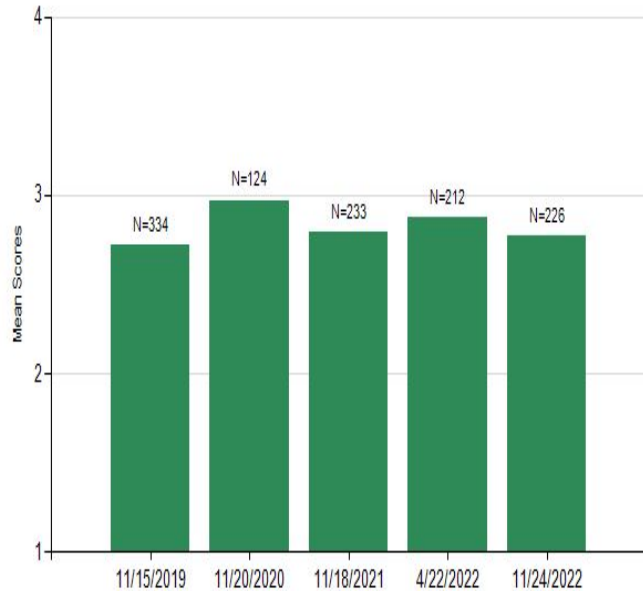

School Climate Survey: Families
-- Total Scores By Survey Date --
School Years: 2019 - 2022

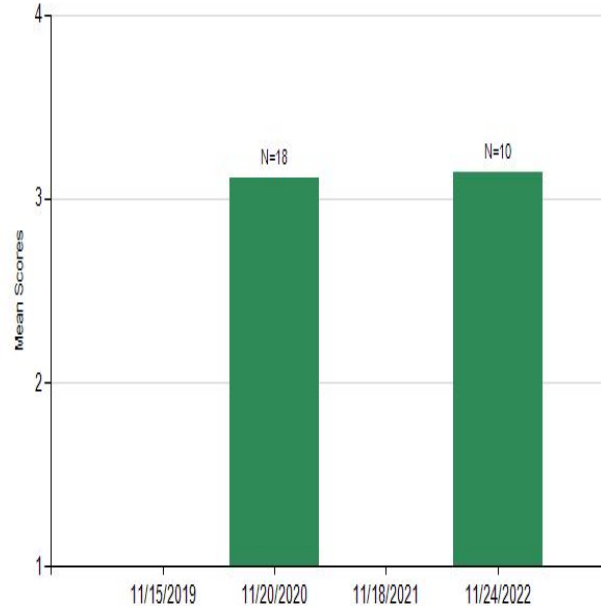

School Climate Survey: School Personnel
-- Total Scores By Survey Date --
School Years: 2019 - 2022

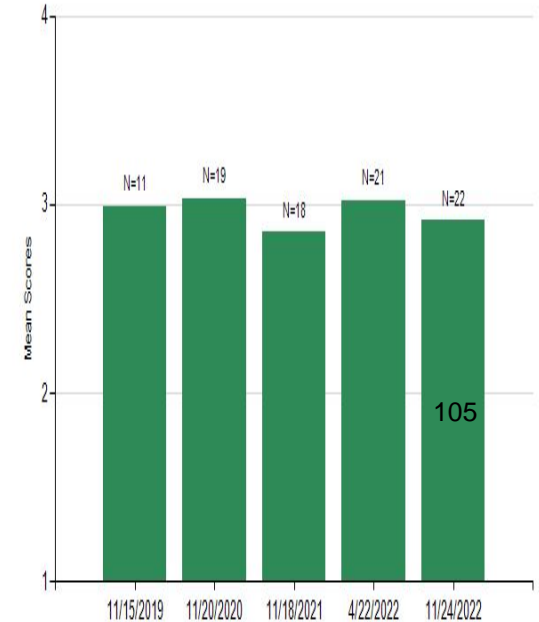

DISTRICT-LEVEL BEHAVIOR TRENDS: AREAS OF ACTION



EDISON

Average Referrals Per Day Per Month - Multi-Year
All, 2019-20 - 2022-23

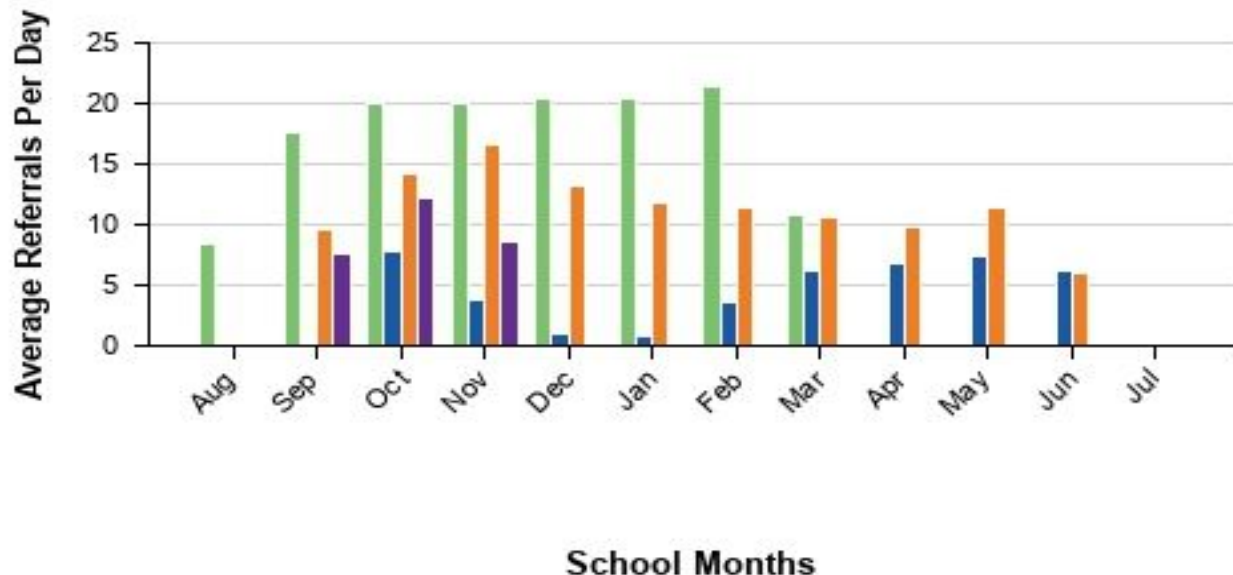

WEBB

Average Referrals Per Day Per Month - Multi-Year
All, 2019-20 - 2022-23

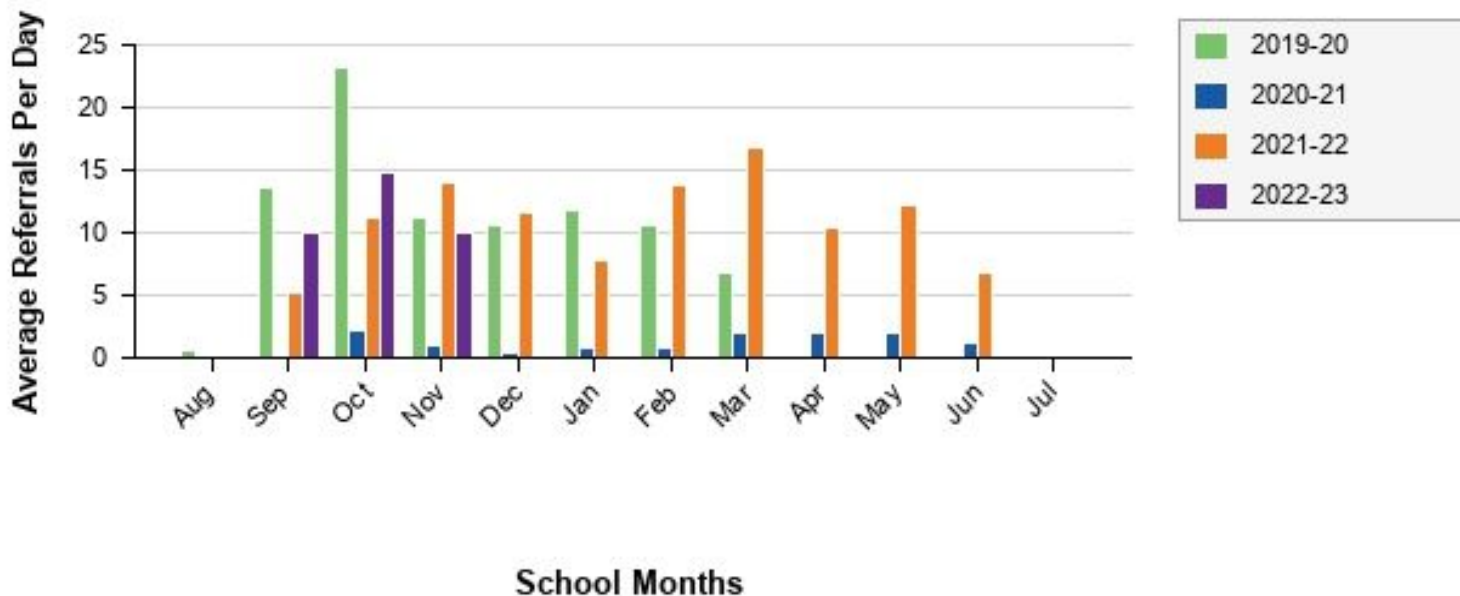

HOOVER

Average Referrals Per Day Per Month - Multi-Year
All, 2019-20 - 2022-23

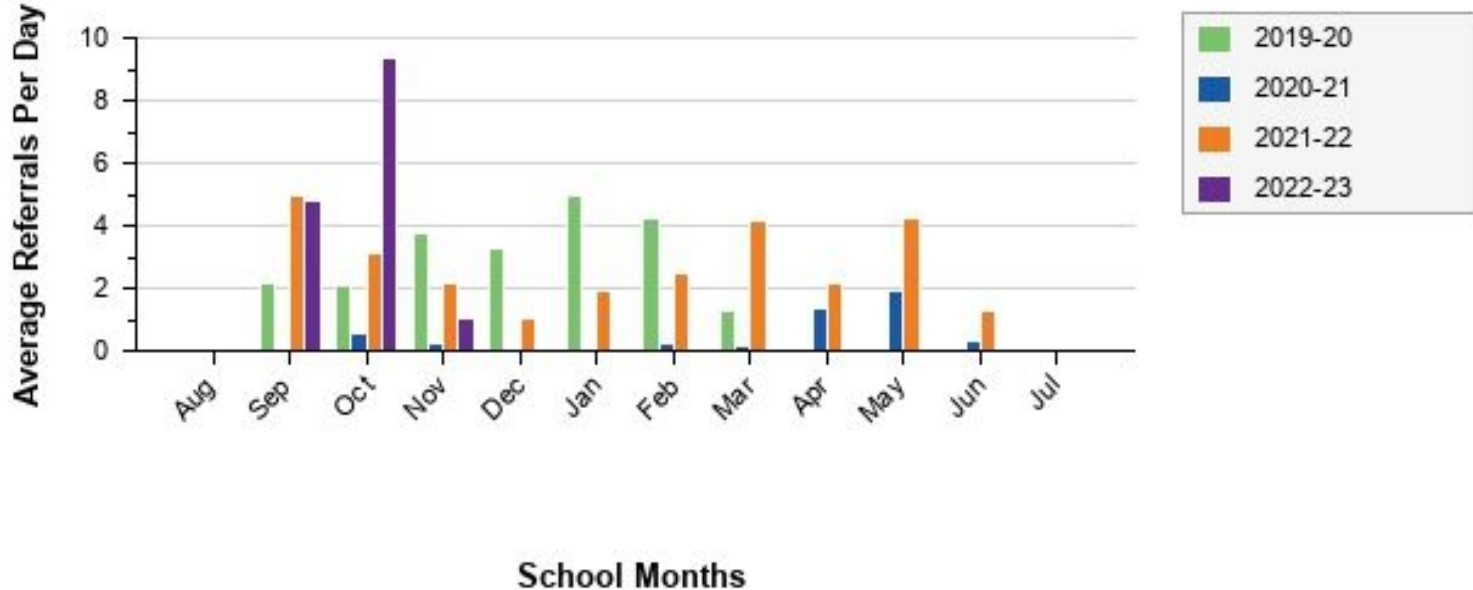

UNITED OAKS

Average Referrals Per Day Per Month - Multi-Year
All, 2019-20 - 2022-23

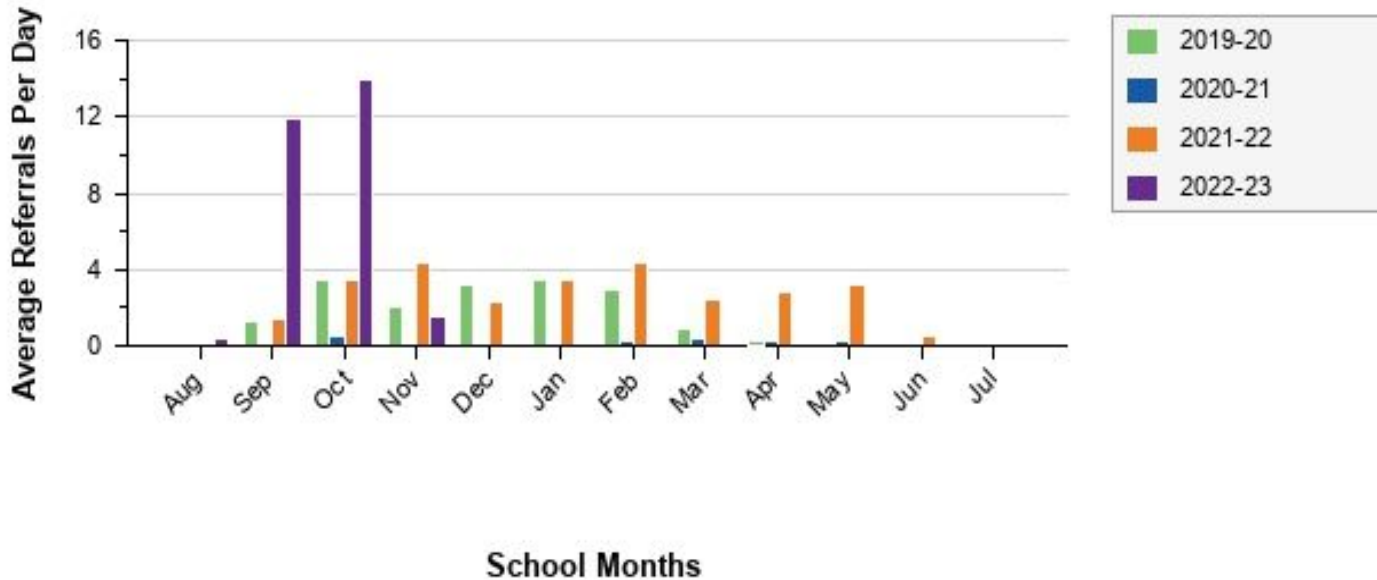

HPJH

Average Referrals Per Day Per Month - Multi-Year
All, 2019-20 - 2022-23

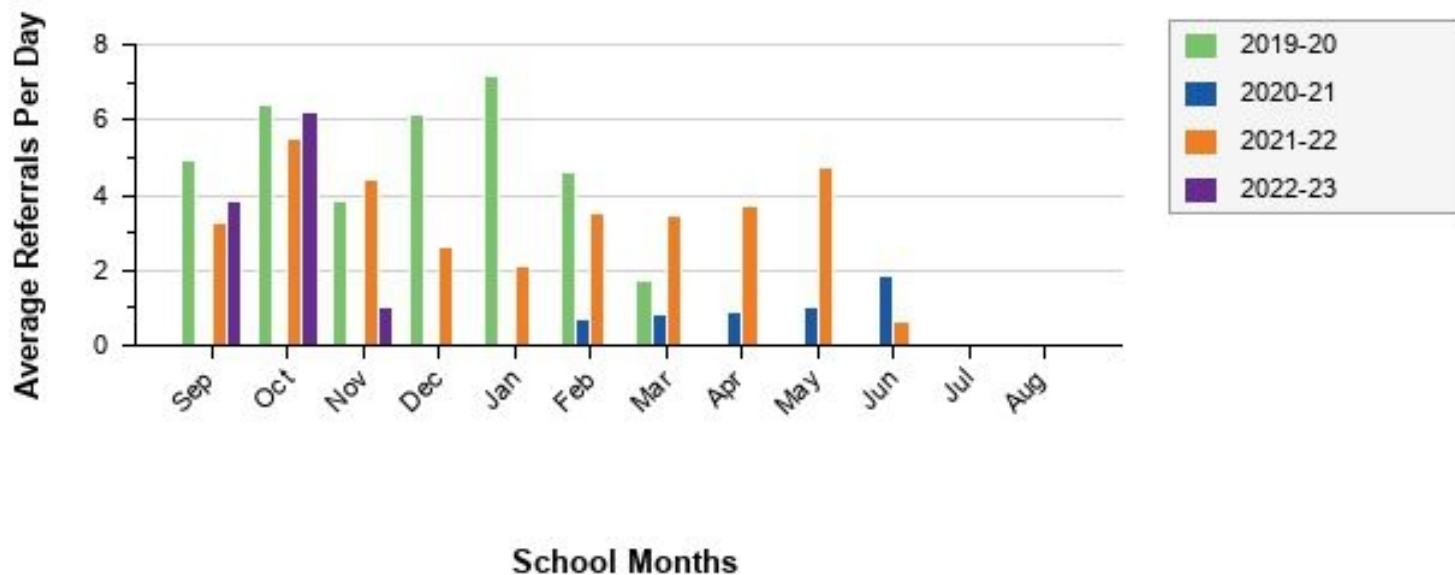

HPHS

Average Referrals Per Day Per Month - Multi-Year
All, 2019-20 - 2022-23

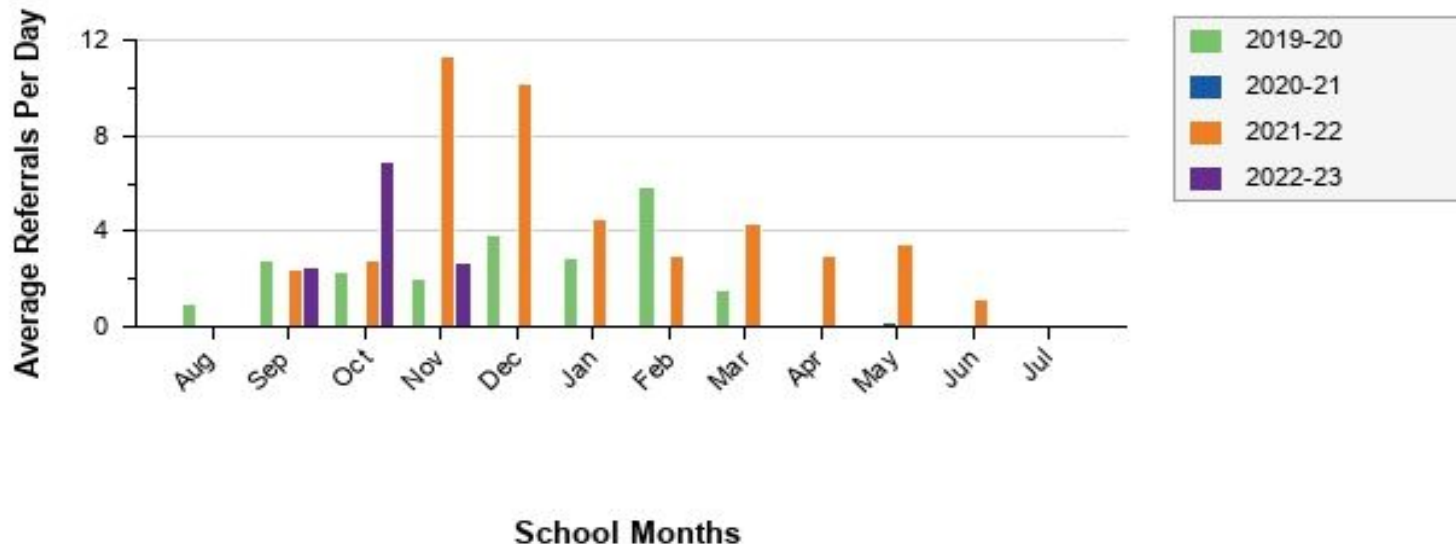

ADVANTAGE

Average Referrals Per Day Per Month - Multi-Year
All, 2019-20 - 2022-23

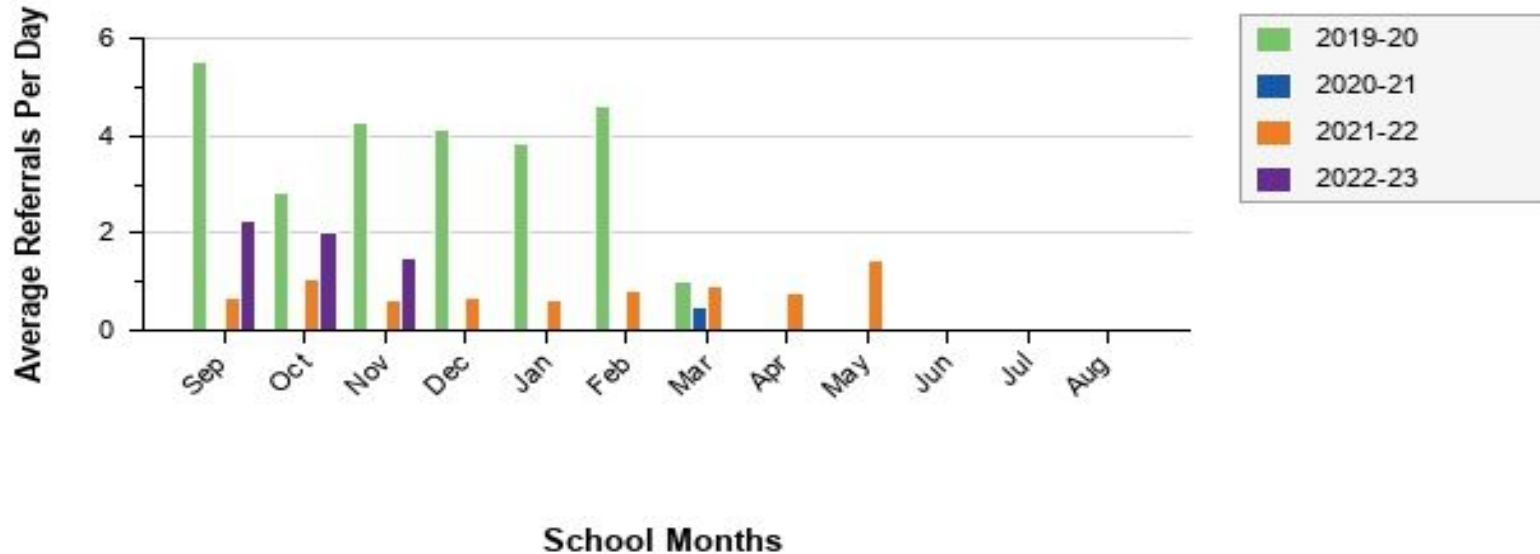

Social Emotional Learning(SEL)

- TRAILS Tier 1 Instruction is being implemented in every building
- 2 Individuals have been training as TRAILS Tier 2 Coaches and will begin training and Coaching Building Mental Health Professionals in January 2023
- The first administration of SAEBRS(**Social, Academic, and Emotional Behavior Risk Screener**) took place in October

QUESTIONS



Hazel Park School District

Regular Board of
Education Meeting
December 12, 2022



Today's Learners, Tomorrow's Leaders



Ford Administration
1620 E. Elza, Hazel Park, MI 48030 | 248-658-5200 | F: 248-544-5223
www.hazelparkschools.org

BOARD OF EDUCATION - SCHOOL OF CHOICE RESOLUTION

WHEREAS, the Hazel Park School District desires to make its schools, grades, and special programs available for enrollment by nonresident students residing within the Oakland School Intermediate School District and its contiguous and non-contiguous Intermediate School Districts to the extent permitted by law, and to count the same in membership pursuant to Section 105 and Section 105c of the State School Aid Act (MCL 388.1705 and 388.1705c), otherwise known as the Schools of Choice legislation for the upcoming 2023-2024 school year;

THEREFORE, BE IT RESOLVED, that the Hazel Park School District shall make such all of its schools, grades, and special programs available for enrollment by nonresident students residing within the Oakland Schools Intermediate School District and its contiguous and non contiguous intermediate School Districts to the extent permitted by law, and count such pupils in membership pursuant to Section 105 and Section 105c of the State School Aid Act (MCL 388.1705 and 388.1705c), otherwise known as the Schools of Choice legislation for the upcoming 2023-2024 school year.

IT IS FURTHER RESOLVED, that the School District, through its Administration, will comply with all of the requirements set forth in MCL 388.1705 and 388.705c for participation in School of Choice.

RESOLUTION DECLARED ADOPTED. December 12, 2022

Laura Adkins, President of Hazel Park Schools Board of Education

Melissa Baldwin, Vice President of Hazel park Schools Board of Education

Amy Kruppe, Ed. D., Superintendent of Hazel Park Schools



Hazel Park City School District
 Enrollment Analysis
 Effective Date: 12/09/2022
 Printed: 12/9/2022 11:34 AM

School	(All)
--------	-------

Count of Student		Grade																	Grand Total	
Status Code	Track	-2	-1	0	1	2	3	4	5	6	7	8	9	10	11	12	14	EA		PH
A	22/23 ADVANTAGE										1	4	6	10	11	24	34			90
	22/23 ADVANTAGE ELEM			2	2		1	1	2											8
	22/23 ADVANTAGE VIRTUAL													2	10	60				72
	22/23 ALL YR JARDON			1	1		2			2	2		1	1			2		6	18
	22/23 EDISON ELEM					2		1	2	6										11
	22/23 EDISON HS													10	9	5	4			28
	22/23 EDISON JHS										3	9	3							15
	22/23 EDISON PH																		5	5
	22/23 HIGH SCHOOL													156	139	151	124			570
	22/23 HOOVER				41	47	49	47	45	44										273 178
	22/23 INVEST													73	78	73	93			317
	22/23 JARDON																		50	50
	22/23 JUNIOR HIGH										146	141	150							437
	22/23 MICH CYBER ACD													99	88	101	51			339
	22/23 UNITED OAKS				64	68	55	61	43	60										351
	22/23 VIKING VIRTUAL													5	8	11	33			57
	22/23 WEBB				62	51	64	60	41	54										332
22/23 WEBSTER CHILDHD		36	77																113	
22/23 WEBSTER ECSE/EA		5	4							1		1		1		1	4	28	45	
A Total		41	82	170	170	170	170	132	168	153	154	161	354	336	375	402	4	28	61	3131
P	22/23 ADVANTAGE															5				5
	22/23 ADVANTAGE VIRTUAL												10	8	16	27				61
	22/23 VIKING VIRTUAL													4	34	43				81
	22/23 WEBSTER CHILDHD			1																1
P Total			1									10	12	50	75					148
Grand Total		41	83	170	170	170	170	132	168	153	154	161	364	348	425	477	4	28	61	3279

School	(All)
--------	-------

Count of Student		Grade																	Grand Total
School Code	Track	-2	-1	0	1	2	3	4	5	6	7	8	9	10	11	12	EA	PH	
01611	21/22 INVEST												58	80	75	68			281
01611 Total													58	80	75	68			281
01616	21/22 HIGH SCHOOL												140	161	127	114			542
01616 Total													140	161	127	114			542
01753	21/22 HOOVER			47	52	41	42	43	43										268
	21/22 HOOVER ELEM VVA			1	2	3	2	4	3										15
01753 Total				48	54	44	44	47	46										283
02176	21/22 MICH CYBER ACD												91	79	95	79			344
02176 Total													91	79	95	79			344
02399	21/22 ALL YR JARDON			2		2		1	1	2	1	1	1		2			6	19
	21/22 JARDON																	47	47
02399 Total				2		2		1	1	2	1	1	1		2			53	66
02954	21/22 VIKING VIRTUAL												10	15	37	70			132
02954 Total													10	15	37	70			132
04159	21/22 EDISON E					1	1	2	3										7
	21/22 EDISON H												7	5	10	5			27
	21/22 EDISON J											5	2	7					14
	21/22 EDISON PH																	4	4
04159 Total						1	1	2	3	5	2	7	7	5	10	5		4	52
04259	21/22 UNITED OAKS			74	47	52	46	53	51										323
	21/22 UNITED OAKS ELEM VVA			1	1		1	4	5										12
04259 Total				75	48	52	47	57	56										335
04422	21/22 WEBSTER CHILDHD	14	69																83
	21/22 WEBSTER ECSE/EA	5	5						1		1		1		1		22		36
04422 Total		19	74						1		1		1		1		22		119
07829	21/22 ADVANTAGE										1		4	2	6	12	52		77
	21/22 ADVANTAGE E								1										1
	21/22 ADVANTAGE VVA												2	7	28	120			157
07829 Total									1	1		4	4	13	40	172			235
09372	21/22 JHS VVA										4	14	14						32
	21/22 JUNIOR HIGH										140	137	146						423
09372 Total											144	151	160						455
09429	21/22 WEBB			56	59	57	42	50	45										309
	21/22 WEBB ELEM VVA				3	6	2	5	1										17
09429 Total				56	62	63	44	55	46										326
Grand Total		19	74	181	164	162	136	162	154	152	155	172	312	353	387	508	22	57	3170

fundraising approval 2022-2023

Sponsors Name	Organization	Type of Fundraiser	Purpose	Beginning Date	Principal/Athletic Director Approved	Superintendent Approved	Board Shared	Amount Raised	Confirm Deposit	Verified by:
Hazel Park Dance Team	HPHS Athletic Boosters	Concessions at Dance Comp	To raise funds for HP Dance Teams	12/3/22	Yes	Yes	12/12/22			
HPHS Drama Club	HPHS Athletic Boosters	Concessions at School Play	To raise funds for Drama Club	11/10/22	Yes	Yes	12/12/22			
Danielle August	Hoover PTA	Bake Sale	Fundraiser for student/staff events	10/6/2022	Yes		12/12/22			
Danielle August	Hoover PTA	Boo Grams	Fundraiser for student/staff events	10/6/2022	Yes		12/12/22			
Danielle August	Hoover PTA	Concessions During Movie Night (water, popcorn)	Fundraiser for student/staff events	10/6/2022	Yes		12/12/22			
United Oaks Elementary	United Oaks PTA	Penny Wars	Raise funds for PTA-led events & activities	11/1/2022	Yes	Yes	12/12/22			
United Oaks Elementary	United Oaks PTA	Holiday Catalog	Raise funds for PTA-led events & activities	11/10/2022	Yes	Yes	12/12/22			
United Oaks Elementary	United Oaks PTA	Santa shop/Movie Night	Raise funds for PTA-led events & activities	12/08/2022	Yes	Yes	12/12/22			
United Oaks Elementary	United Oaks PTA	Valentine's Day Carnations	Raise funds for PTA-led events & activities	01/30/2023	Yes	Yes	12/12/22			
United Oaks Elementary	United Oaks PTA	Chocolate Fundraiser	Raise funds for PTA-led events & activities	04/01/2023	Yes	Yes	12/12/22			
United Oaks Elementary	United Oaks PTA	PTA Carnival	Raise funds for PTA-led events & activities		Yes	Yes	12/12/22			
Webb Elementary	5th grade camp	pizza kits little ceesar	5th grade camp	2/8/2023	yes	Yes	12/12/22			
Hazel Park Band Boosters	Hazel Park Band Boosters	Catalogue cookie dough	Raise funds for end of year party for all band members	11/16/22		Yes	12/12/22			
Webb PTA	Webb PTA	Spiritwear Sale	Give Webb families opportunity to purchase Webb spirit wear	11/14/22	Yes	Yes	12/12/22			
Webb PTA	Webb PTA	Santa Shop		11/14/22	Yes	Yes	12/12/22			

2022-2023
Discipline
August to Jan.



121

Today's Learners, Tomorrow's Leaders

Discipline per Grade.

District Wide Disciplines by Grade Level

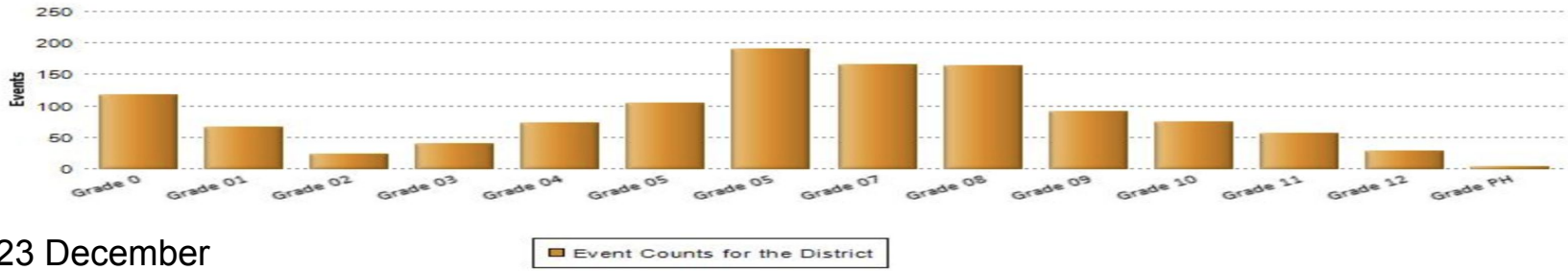

2022-2023 December

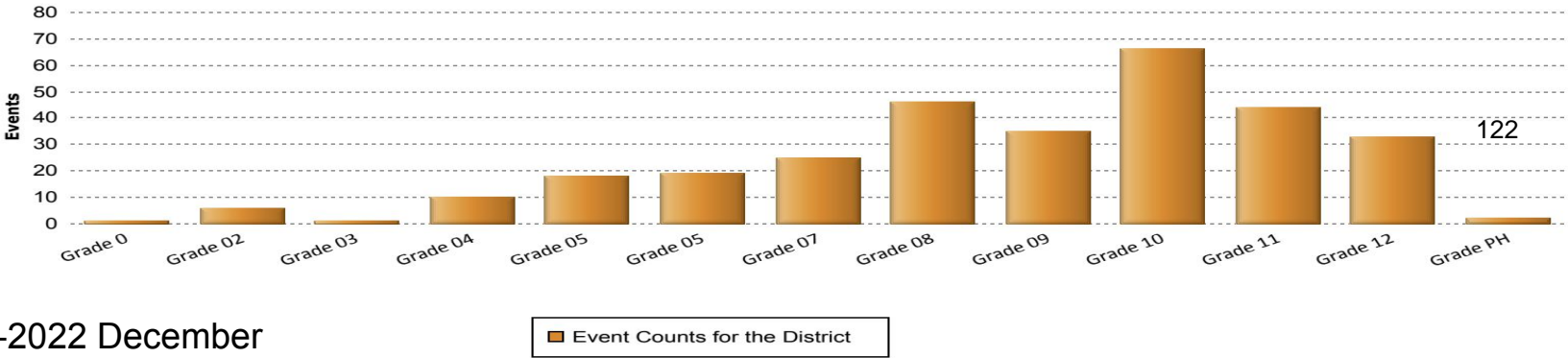

2021-2022 December

District Discipline by Ethnicity 2022-2023

2021-2022

School	Ethnicity	Total Events	Ethnicity Count	Ethnicity Ratio	Ethnicity Percent
Discipline Events by Ethnicity					
Edison MAX					
	Asian	3	2	1 Event Per Each 0.7 Enrolled Students	150.0%
	Black or African American	56	19	1 Event Per Each 0.3 Enrolled Students	294.7%
	Hispanic	2	4	1 Event Per Each 2.0 Enrolled Students	50.0%
	White	31	34	1 Event Per Each 1.1 Enrolled Students	91.2%
Hoover Elementary					
	Black or African American	59	120	1 Event Per Each 2.0 Enrolled Students	49.2%
	White	36	137	1 Event Per Each 3.8 Enrolled Students	26.3%
United Oaks Elementary					
	American Indian or Alaska Native	1	3	1 Event Per Each 3.0 Enrolled Students	33.3%
	Black or African American	44	166	1 Event Per Each 3.8 Enrolled Students	26.5%
	Hispanic	3	23	1 Event Per Each 7.7 Enrolled Students	13.0%
	White	86	155	1 Event Per Each 1.8 Enrolled Students	55.5%
Webb Elementary					
	Asian	4	4	1 Event Per Each 1.0 Enrolled Students	100.0%
	Black or African American	63	135	1 Event Per Each 2.1 Enrolled Students	46.7%
	Hispanic	2	20	1 Event Per Each 10.0 Enrolled Students	10.0%
	White	61	167	1 Event Per Each 2.7 Enrolled Students	36.5%
Hazel Park Junior High School					
	American Indian or Alaska Native	13	10	1 Event Per Each 0.8 Enrolled Students	130.0%
	Black or African American	249	206	1 Event Per Each 0.8 Enrolled Students	120.9%
	Hispanic	33	22	1 Event Per Each 0.7 Enrolled Students	150.0%
	White	175	197	1 Event Per Each 1.1 Enrolled Students	88.8%
Hazel Park High School					
	American Indian or Alaska Native	1	2	1 Event Per Each 2.0 Enrolled Students	50.0%
	Asian	2	6	1 Event Per Each 1.3 Enrolled Students	33.3%
	Black or African American	118	277	1 Event Per Each 2.3 Enrolled Students	42.6%
	Hispanic	4	26	1 Event Per Each 6.5 Enrolled Students	15.4%
	White	36	258	1 Event Per Each 7.2 Enrolled Students	14.0%
District Totals					
	American Indian or Alaska Native	15	15	1 Event Per Each 1.0 Enrolled Students	100.0%
	Asian	9	12	1 Event Per Each 1.3 Enrolled Students	75.0%
	Black or African American	589	923	1 Event Per Each 1.6 Enrolled Students	63.8%
	Hispanic	44	95	1 Event Per Each 2.2 Enrolled Students	46.3%
	White	425	948	1 Event Per Each 2.2 Enrolled Students	44.8%

School	Ethnicity	Total Events	Ethnicity Count	Ethnicity Ratio	Ethnicity Percent
Discipline Events by Ethnicity					
Edison MAX					
	Black or African American	16	19	1 Event Per Each 1.2 Enrolled Students	84.2%
	White	21	31	1 Event Per Each 1.5 Enrolled Students	67.7%
Hoover Elementary					
	Black or African American	6	130	1 Event Per Each 21.7 Enrolled Students	4.6%
	White	1	148	1 Event Per Each 148.0 Enrolled Students	0.7%
United Oaks Elementary					
	White	2	155	1 Event Per Each 77.5 Enrolled Students	1.3%
Webb Elementary					
	American Indian or Alaska Native	5	10	1 Event Per Each 2.0 Enrolled Students	50.0%
	Black or African American	4	139	1 Event Per Each 34.8 Enrolled Students	2.9%
	White	14	162	1 Event Per Each 11.6 Enrolled Students	8.6%
Hazel Park Junior High School					
	American Indian or Alaska Native	2	8	1 Event Per Each 4.0 Enrolled Students	25.0%
	Black or African American	43	211	1 Event Per Each 4.9 Enrolled Students	20.4%
	Hispanic	2	23	1 Event Per Each 11.5 Enrolled Students	8.7%
	White	27	212	1 Event Per Each 7.9 Enrolled Students	12.7%
Hazel Park High School					
	American Indian or Alaska Native	3	3	1 Event Per Each 1.0 Enrolled Students	100.0%
	Black or African American	82	250	1 Event Per Each 3.0 Enrolled Students	32.8%
	Hispanic	3	20	1 Event Per Each 6.7 Enrolled Students	15.0%
	White	35	265	1 Event Per Each 7.6 Enrolled Students	13.2%
District Totals					
	American Indian or Alaska Native	10	21	1 Event Per Each 2.1 Enrolled Students	47.6%
	Black or African American	151	749	1 Event Per Each 5.0 Enrolled Students	20.2%
	Hispanic	5	43	1 Event Per Each 8.6 Enrolled Students	11.6%
	White	100	973	1 Event Per Each 9.7 Enrolled Students	10.3%

Types of Behavior

District Wide Disciplines by Type

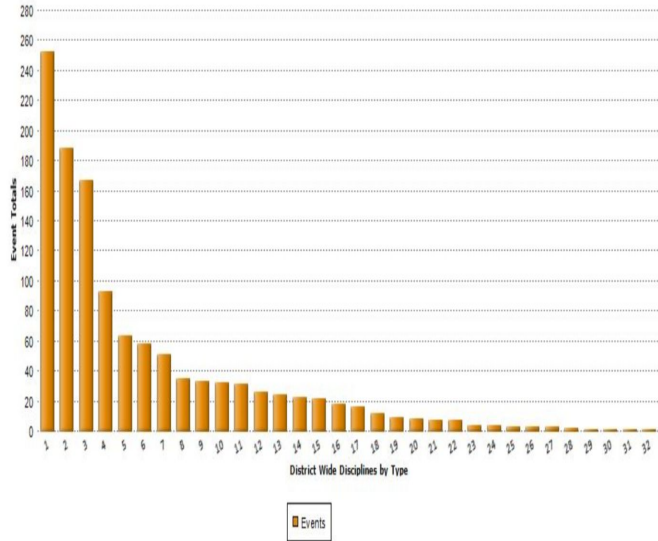

Event Index Reference

Column #	Description	Event Total
1	Fighting/Physical Aggression	252
2	Disruptive Behavior	188
3	Defiance/Disresp/Insubord/Noncomp	167
4	Abusive/Inapp/Profanity Lang	93
5	Minor - Physical contact/aggress	63
6	Minor - Defia/Disre/Insub/Noncom	58
7	Technology Violation	51
8	Skip Class/Tuancy	35
9	Disruption	33
10	Other Behavior	32
11	Use/Poss of Tobacco	31
12	Unauth. Use of Elect. Devices	28
13	Use/Poss of Drug	24
14	Disobedience	22
15	Property Damage/Vandalism	21
16	Tardy	18
17	Harassment/Bullying	16
18	Minor - Inappropriate Language	12
19	Inappropriate display of affecto	9
20	Minor - Technology Violation	8
21	Inappropriate Location/out of bo	7
22	Bomb Threat/False Alarm	7
23	Forgery/Theft	4
24	Poss Of Weapon	4
25	Vandalism	3
26	Minor - disruption	3
27	Sleeping in class	3
28	Minor - Property Misuse	2
29	Lying/Cheating	1
30	Minor - Dress Code Violation	1
31	Dress Code Violation	1
32	Minor - other	1

District Wide Disciplines by Type

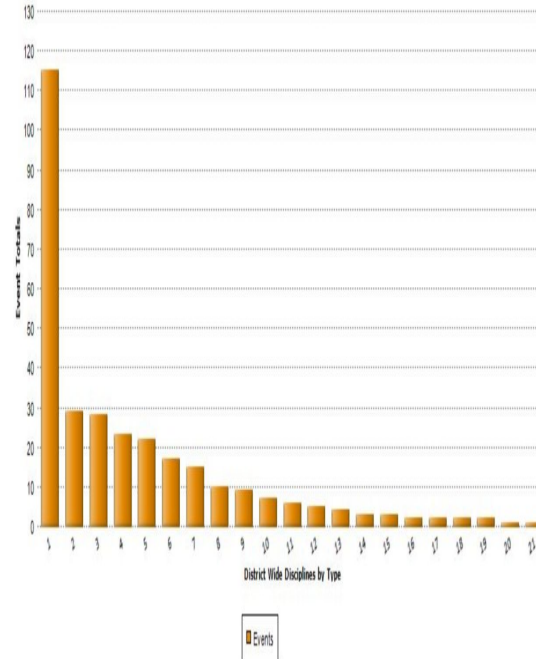

Event Index Reference

Column #	Description	Event Total
1	Fighting/Physical Aggression	115
2	Minor - Defia/Disre/Insub/Noncom	29
3	Use/Poss of Tobacco	28
4	Defiance/Disresp/Insubord/Noncomp	23
5	Abusive/Inapp/Profanity Lang	22
6	Technology Violation	17
7	Other Behavior	15
8	Use/Poss of Drug	10
9	Skip Class/Tuancy	9
10	Minor - Technology Violation	7
11	Minor - Physical contact/aggress	6
12	Property Damage/Vandalism	5
13	Minor - other	4
14	Minor - disruption	3
15	Poss Of Weapon	3
16	Disruption	2
17	Forgery/Theft	2
18	Inappropriate display of affecto	2
19	Lying/Cheating	2
20	Harassment/Bullying	1
21	Asson	1

124

District Discipline

District Wide Action Summary

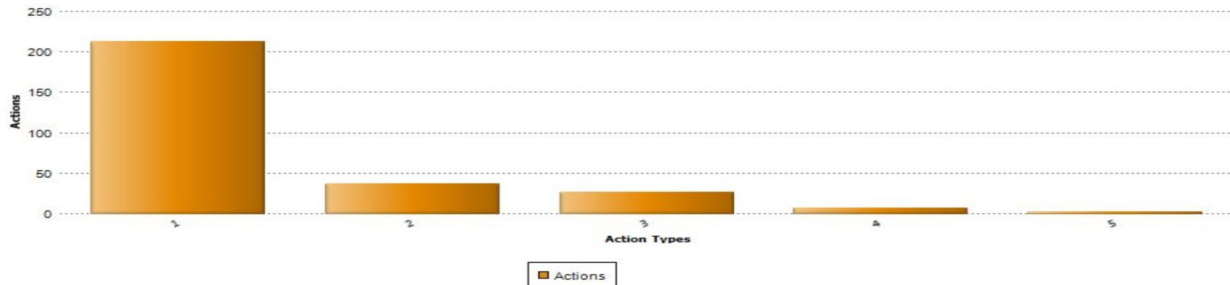

Action Index Reference

Column #	Description	ActionTotal
1	Out of School Suspension	213
2	Seclusion	37
3	Restraint	27
4	Citation issued	7
5	In School Suspension	2



District Wide Action Summary

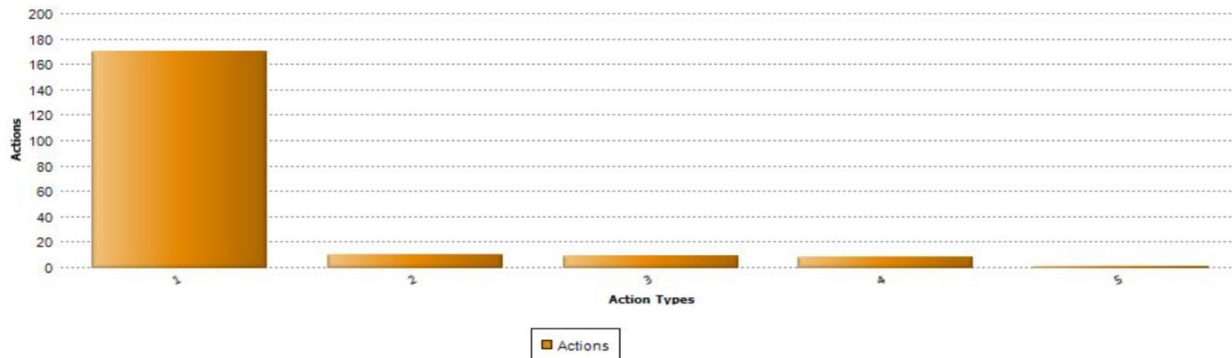

Action Index Reference

Column #	Description	ActionTotal
1	Out of School Suspension	170
2	Restraint	10
3	Seclusion	9
4	In School Suspension	8
5	Individual learning experience	125 1



Attendance over Discipline

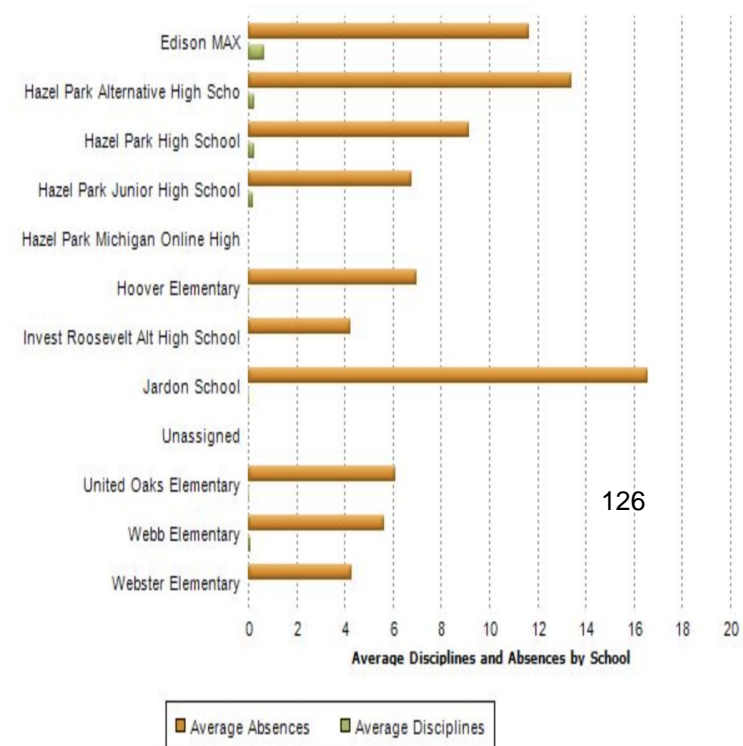
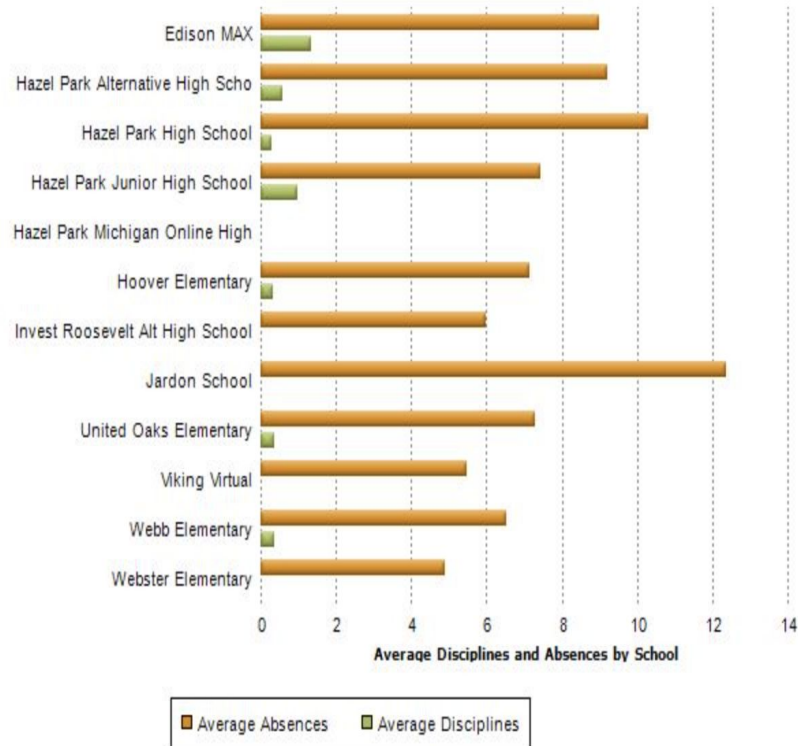

Student Discipline by Other Events

DIS - Event Counts by Other Category:

School	Total	Male	Female	F & R	Migrant	Homeless	SpecEd	ELL	Gifted
District Wide	1,196	807	389	860	0	4	323	12	0
Edison MAX	92	86	6	38	0	0	87	2	0
Hazel Park Alternative High Scho	114	84	30	89	0	0	29	0	0
Hazel Park High School	161	103	58	114	0	0	43	0	0
Hazel Park Junior High School	470	285	185	357	0	4	51	6	0
Hoover Elementary	95	29	66	50	0	0	22	0	0
United Oaks Elementary	134	113	21	107	0	0	42	0	0
Webb Elementary	130	107	23	105	0	0	49	4	0

DIS - Event Counts by Other Category:

School	Total	Male	Female	F & R	Migrant	Homeless	SpecEd	ELL	Gifted
District Wide	306	217	89	223	0	1	96	4	0
Edison MAX	37	37	0	18	0	0	36	0	0
Hazel Park Alternative High Scho	39	27	12	30	0	1	4	0	0
Hazel Park High School	123	83	40	97	0	0	26	0	0
Hazel Park Junior High School	74	42	32	53	0	0	10	4	0
Hoover Elementary	7	5	2	7	0	0	5	0	0
Jardon School	1	1	0	0	0	0	1	0	0
United Oaks Elementary	2	1	1	0	0	0	0	0	0
Webb Elementary	23	21	2	18	0	0	14	0	0

Student Discipline by Day of the week

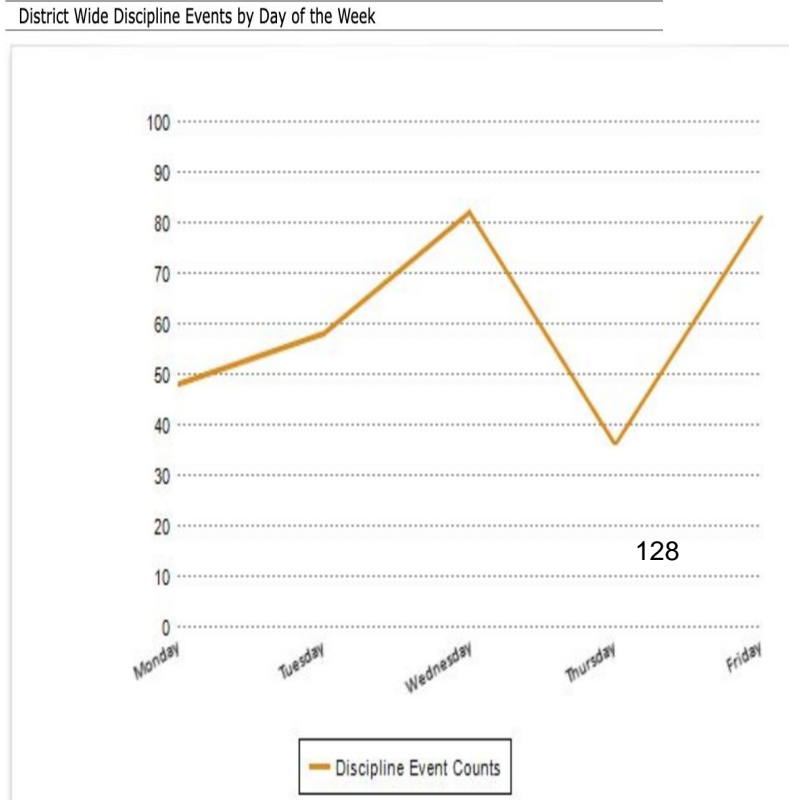
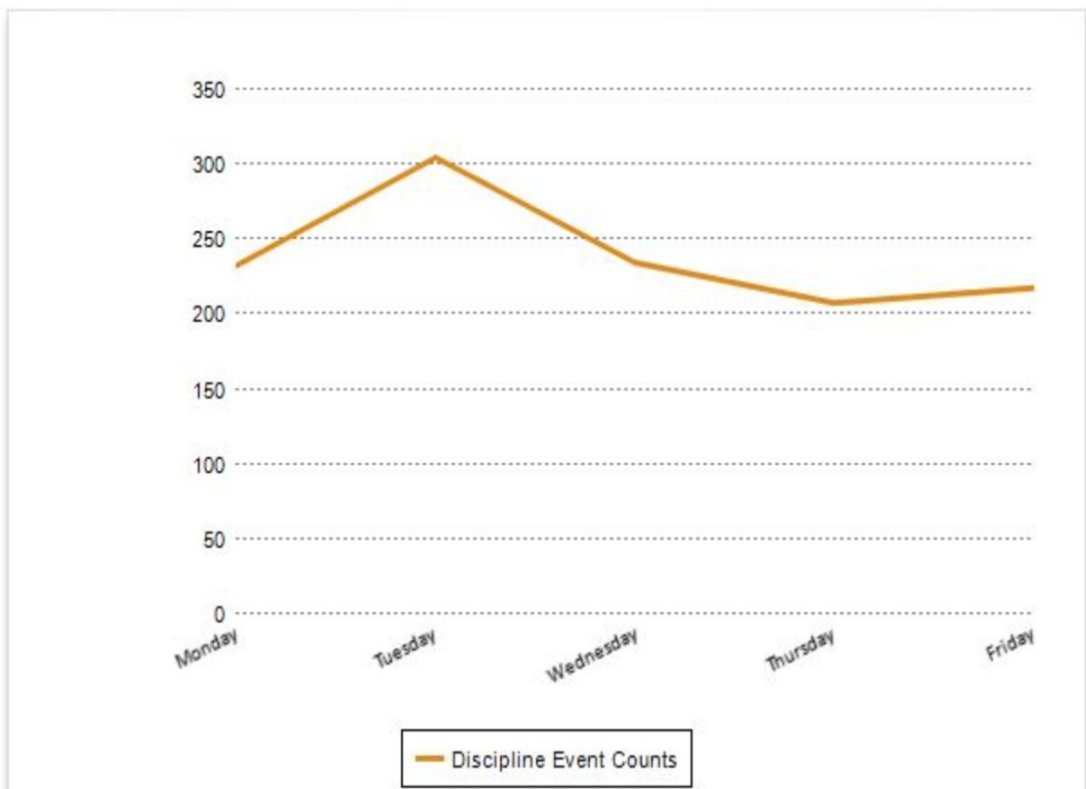

Administrator Coaching Feedback December 2022 ~Marion Ginopolis

Position

9 responses

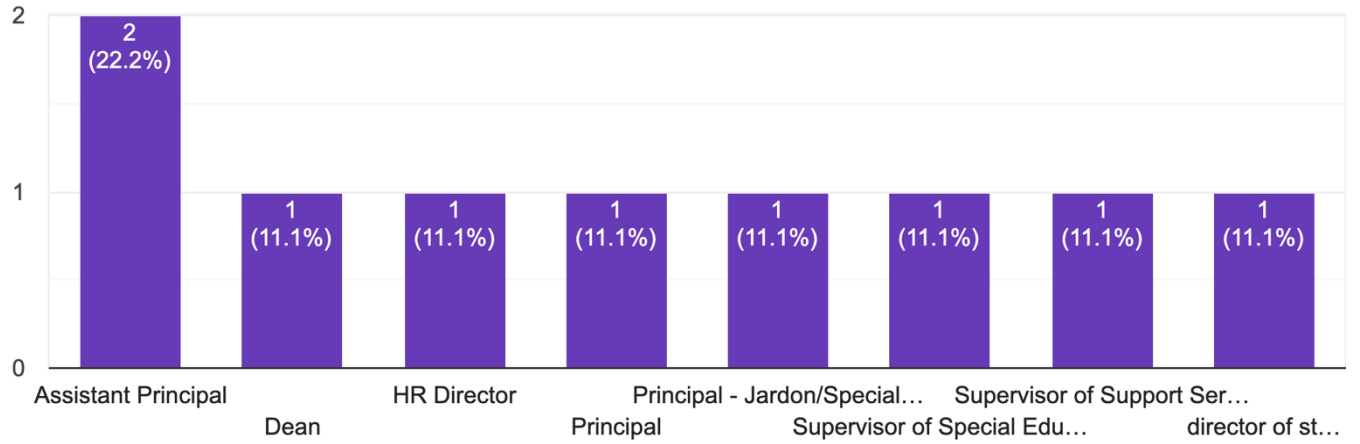

Marion responds in a timely manner

9 responses

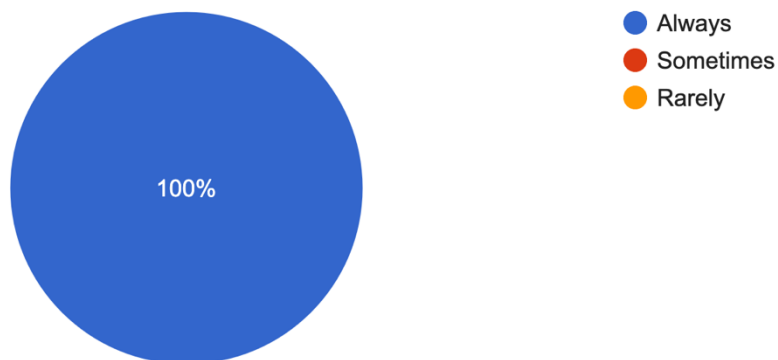

Administrator Coaching Feedback December 2022 ~Marion Ginopolis

Marion is flexible with meeting time changes when my schedule has conflicts

9 responses

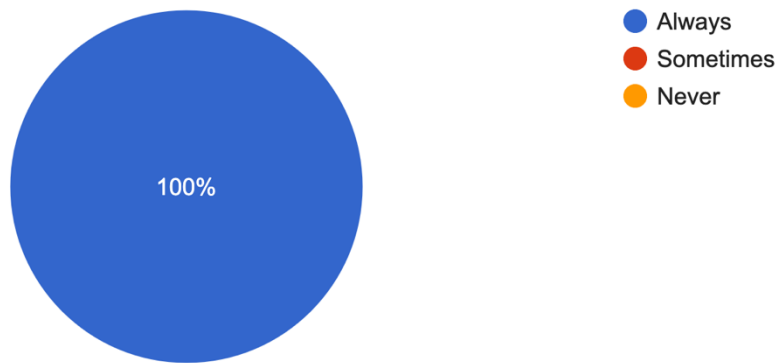

Marion has provided me with valuable resources relevant to my job responsibilities

9 responses

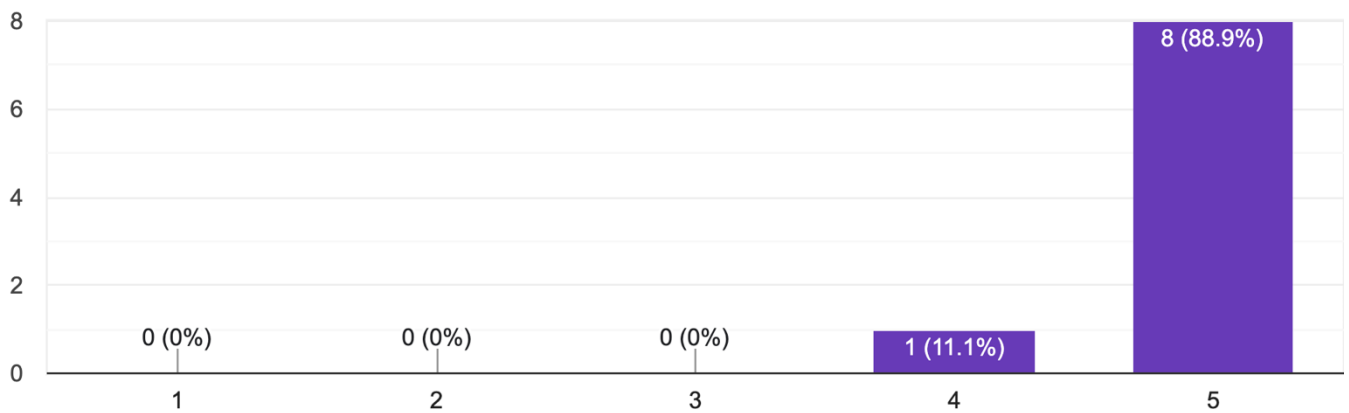

Administrator Coaching Feedback December 2022 ~Marion Ginopolis

I feel that Marion respects my privacy and I can be candid with her relevant to any concerns I have.

9 responses

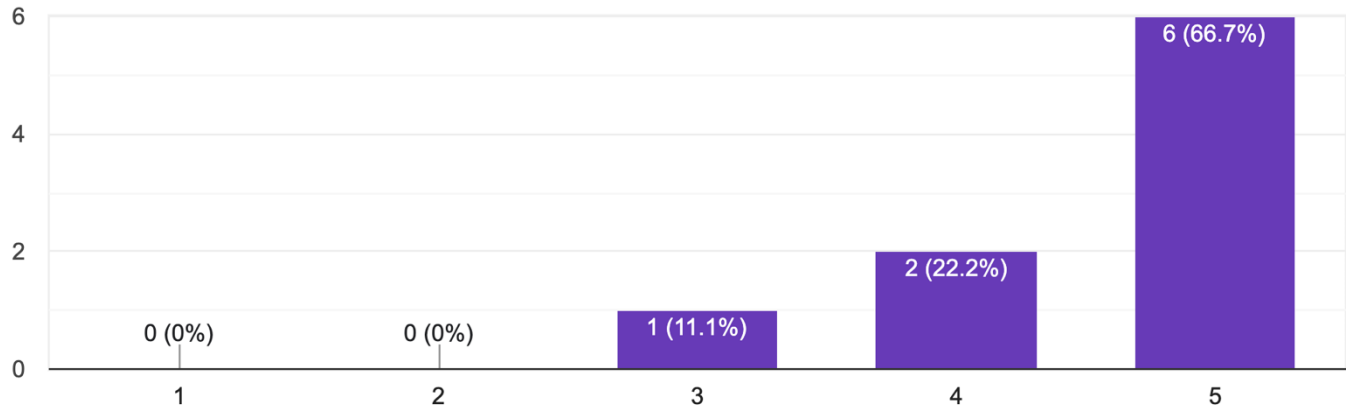

Marion's experiences and expertise have been of great value when discussing strategies relevant to my job.

9 responses

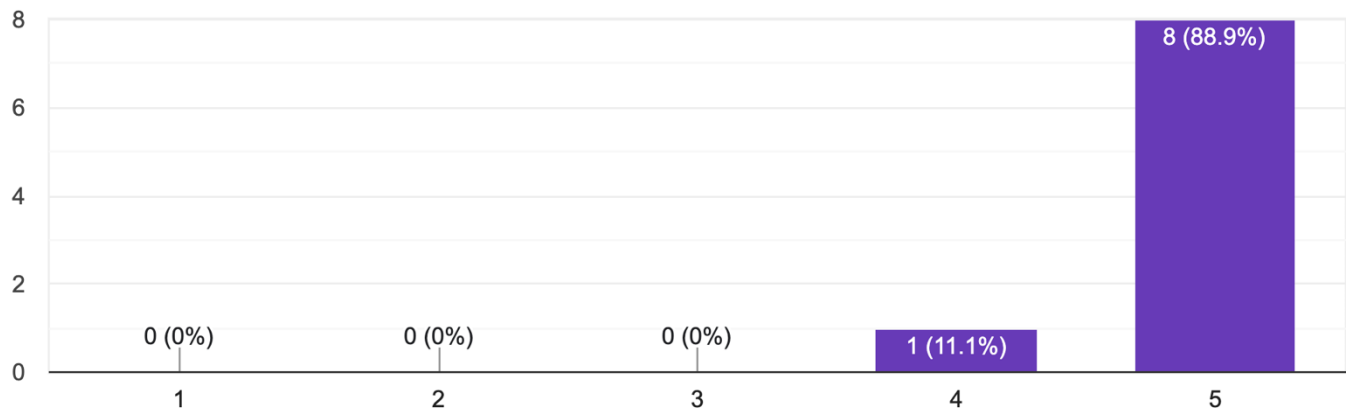

Administrator Coaching Feedback December 2022 ~~Marion Ginopolis

I would not hesitate to contact Marion outside of our regularly scheduled meeting time to ask questions, get advice, run an idea by her, etc.

9 responses

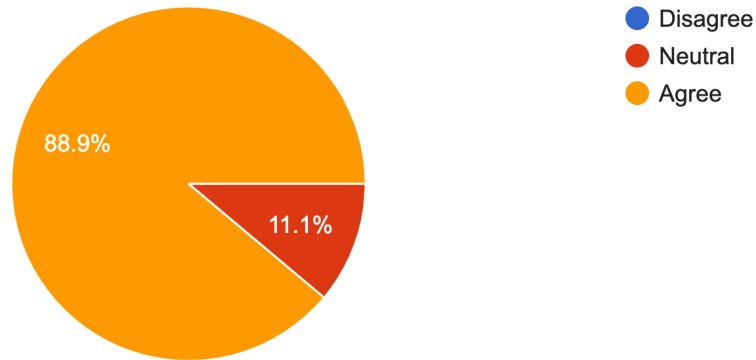

Marion has provided me with connections to outside resources/peers in other districts that have been extremely valuable.

9 responses

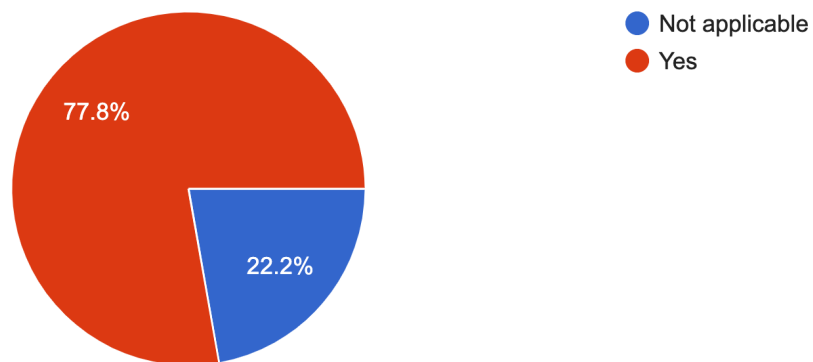

Administrator Coaching Feedback December 2022 ~~Marion Ginopolis

If you have found this coaching experience to be of value, please indicate the benefit and value this experience has had for you thus far in your position. Be specific.

- It is nice to talk to someone with so much experience and that really listens
- Marion is a neutral party who has a wealth of knowledge and expertise that is much appreciated.
- Her guidance and tools for evaluations has been extremely beneficial.
- *weekly goals to focus practice *mentoring in the areas of: communication, leadership, practices and procedures *networking resources *problem solving
- Marion has been a great resource for me to turn to as I navigate through my first experience in administration. She is proactive and has great resources and ideas. She is always willing to help and always available. She has been so very flexible in working with me as well. Marion has helped guide me on how to deal with difficult situations, how to work on developing positive building culture, and connected me with others who are in my shoes in the county. I am very pleased that I have the opportunity to work with her and hope that this continues.
- It has been wonderful having Marion as a mentor as I've started this new position to discuss ideas and challenges with on a regular basis. Thank you!
- Marion has provided me with thoughtful, relative advice and ideas to support my role.
- Meeting with Marion has been a pleasure as a new administrator. She provides advice and resources for me to consider as a leader at the high school. I enjoy the coaching sessions as she has a ton of experience in education.
- Marion has been great during my transition into this position. I have had some very valuable conversations with her and she is a wealth of information.

I would like to continue this coaching opportunity throughout the school year.

9 responses

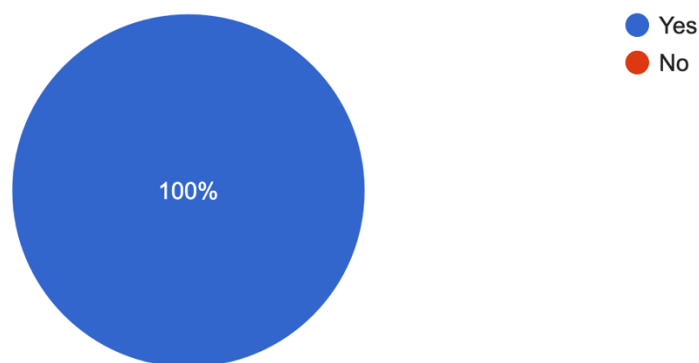

Administrator Coaching Feedback December 2022 ~~Marion Ginopolis

If you have found this coaching experience to be of value, please indicate the benefit and value this experience has had for you thus far in your position. Be specific.

- It is nice to talk to someone with so much experience and that really listens
- Marion is a neutral party who has a wealth of knowledge and expertise that is much appreciated.
- Her guidance and tools for evaluations has been extremely beneficial.
- *weekly goals to focus practice *mentoring in the areas of: communication, leadership, practices and procedures *networking resources *problem solving
- Marion has been a great resource for me to turn to as I navigate through my first experience in administration. She is proactive and has great resources and ideas. She is always willing to help and always available. She has been so very flexible in working with me as well. Marion has helped guide me on how to deal with difficult situations, how to work on developing positive building culture, and connected me with others who are in my shoes in the county. I am very pleased that I have the opportunity to work with her and hope that this continues.
- It has been wonderful having Marion as a mentor as I've started this new position to discuss ideas and challenges with on a regular basis. Thank you!
- Marion has provided me with thoughtful, relative advice and ideas to support my role.
- Meeting with Marion has been a pleasure as a new administrator. She provides advice and resources for me to consider as a leader at the high school. I enjoy the coaching sessions as she has a ton of experience in education.
- Marion has been great during my transition into this position. I have had some very valuable conversations with her and she is a wealth of information.

I would like to continue this coaching opportunity throughout the school year.

9 responses

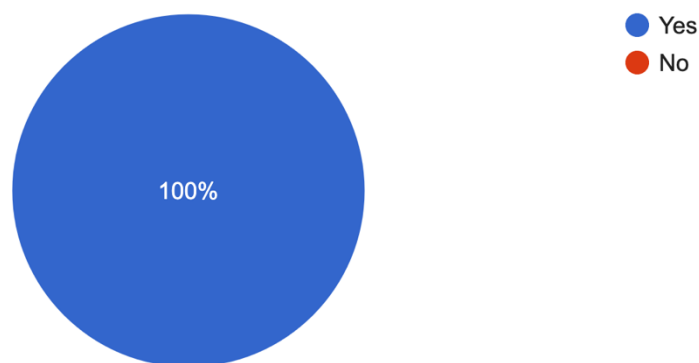

RESOURCES

Podcasts for Leaderful Schools (click this link to access)

<https://podcast-for-leaderful-schools.simplecast.com/episodes>



Five Minutes for Leadership newsletters - *Invest 5 Minutes in Your Leadership: Reflect, Energize, Act*

Motivating Teachers During Difficult Times

http://www.toddwhitaker.com/cms/uploads/Motivating_Teachers_During_Difficult_Times.pdf

What Great Principals Really Do <https://t.e2ma.net/webview/r01yff/6cab15148bed2cb535e0babc52ac7e51>

The Path to the Next Normal in Education <https://t.e2ma.net/webview/rsrdef/ef7696394554f6e4f254aff1d1be442b>

The 5 Levels of Leadership: Which One are You? <https://t.e2ma.net/webview/rgas4e/bebbaf5e9fd9c4e78820e71bfa583cff>

Why you lead determines how you lead <https://t.e2ma.net/message/nt1edg/frqaivu>

Build Teams that Own Their Roles as Leaders <https://t.e2ma.net/message/bkq67f/frqaivu>

SURVEY RESULTS

Thank you to those who were able to complete the survey. Below are a few responses to the survey question...

In the current educational climate (post Covid), what are some areas you might identify as challenges?

- Staff buy-in to new curriculum.
- Staff and students feeling safe, making up for loss with our students
- Complacency amongst staff - the "quiet quitting" concept.
- Student: academic growth, social/emotional development
- Truancy
- Hiring and professional development
- Staff shortages
- Many suffered trauma through the pandemic. Being aware of the mental health of students, teachers, and staff. Meeting their individual social and emotional needs can be a challenge.
- SEL for the kids still struggling

"GHOST BUSTERS" You call, I'll respond!

...facing a challenge, have a question, want to avoid a crisis?

Contact Marion Ginopolis, Hazel Park Schools Administrative Coach

marion.ginopolis@myhpsd.org 248-343-2648



WORDS OF WISDOM

“How you say what you say matters”

<https://www.edweek.org/leadership/effective-communication-for-school-leaders>

That’s the driving idea behind this new special report exploring what good communication looks like for school leaders.

Effective Communication for School Leaders: A Forum --How school and district leaders can motivate staff, make the most of social media, and more. Thu., October 13, 2022, 2:00 p.m. - 4:30 p.m. (Free)

SCHOOL CULTURE

*School culture is the set of norms, values and beliefs, rituals and ceremonies, symbols and stories that make up the “persona” of the school. It is the **historically transmitted pattern of meaning** that wields astonishing power in shaping what people think and how they act. ~~Kent D. Peters*

Schools can have a healthy culture or a toxic culture...How is culture evidenced?

~~What do **you see, hear, and experience** in the school? What **don’t** you see and hear?

~~What are the **clues** that reveal the school’s culture?

~~What behaviors get **rewards and status** here? Which ones are greeted with **reprimands**?

~~Do the **adults model** the behavior they expect of students?

~~Who gets to make the **decisions**?

~~Do parents experience **welcome, suspicion, or rejection** when they enter the school?

Is Your School's Culture Toxic or Positive?

https://www.educationworld.com/a_admin/admin/admin275.shtml

***School Culture: The Hidden Curriculum* by Craig Jerald**

<https://www.readingrockets.org/article/school-culture-hidden-curriculum>

“GHOST BUSTERS” You call, I’ll respond!
136

...facing a challenge, have a question, want to avoid a crisis?

Contact Marion Ginopolis, Hazel Park Schools Administrative Coach

marion.ginopolis@myhpsd.org 248-343-2648



RESOURCES

Power Plays of Difficult Employees by TODD C. WHITAKER A three-question litmus test to gauge the likely effect of your rules to change bad behavior

<https://www.aasa.org/SchoolAdministratorArticle.aspx?id=9276>

Teacher burnout hits record high

<https://theconversation.com/teacher-burnout-hits-record-high-5-essential-reads-185550>

NEA survey: Massive staff shortages in schools leading to educator burnout; alarming number of educators indicating they plan to leave profession

<https://www.nea.org/about-nea/media-center/press-releases/nea-survey-massive-staff-shortages-schools-leading-educator>

Podcasts for Leaderful Schools (click this link to access)

<https://podcast-for-leaderful-schools.simplecast.com/episodes>

Current and past issues of this newsletter and materials from the Culture presentation (PowerPoint and Toxic audio) can be accessed in a folder on the Share Drive titled *Admin Coach Ginopolis – Materials and Resources*.



Assess the culture of your school or department

- **Culture walks** refer to the activity of physically going around a workplace and observing concrete signs of culture, such as workspace usage, tone of conversations and employee interactions.
- **Informative interviews** refer to the process of soliciting feedback from small groups of employees about workplace behaviors and patterns they've observed.
- **Surveys** refer to written evaluations taken by stakeholders within the organization.

“GHOST BUSTERS” You call, I’ll respond!

...facing a challenge, have a question, want to avoid a crisis?

Contact Marion Ginopolis, Hazel Park Schools Administrative Coach

marion.ginopolis@myhpsd.org 248-343-2648



HOLIDAY MESSAGE

As the holiday season is upon us, please accept my best wishes and greetings of the season. This is a time to be with family and friends and be thankful for the gifts that we have in our lives.

During this very hectic time of year, it is easy to lose sight of what really matters in life. I hope everyone will find some time for themselves to reflect on what is important and to enjoy time with loved ones. Additionally, please keep in mind those who are less fortunate or find themselves in difficult circumstances.

I wish a Merry Christmas to those who celebrate this blessed day and to everyone a peaceful, joyous holiday season. As we begin the New Year, may we continue to work together to meet the challenges that lie ahead. With warmest wishes to you and yours, ~~Marion Ginopolis

ASK THE RIGHT QUESTIONS TO ELICIT REFLECTIVE THINKING

Reflective thinking requires you to recognize, understand and to define the valuable knowledge and experience brought to each new situation, to make the connections based on prior learning and experience ('insight'), and bring these to bear in the context of new events.

**Asking open-ended questions (as opposed to closed questions)
leads to reflection.**

What is the difference between closed and open questions?

A closed question is simply one that the participant can answer 'yes' or 'no' or a short answer. An open question requires far more detail and invites the person responding to provide information into how they feel and what they think about a subject.

Examples

<closed> Did your staff meeting go well?

<open> What went well in your staff meeting? What did not go well?

<closed> Did you learn anything important when you....?

<open> What did you learn when you...?

<closed> Do you expect any push-back from staff when you implement this new policy?

<open> What push-back do you anticipate from staff when you implement this new policy?

"GHOST BUSTERS" You call, I'll respond!

...facing a challenge, have a question, want to avoid a crisis?

Contact Marion Ginopolis, Hazel Park Schools Administrative Coach

marion.ginopolis@myhpsd.org 248-343-2648

WORDS OF WISDOM

"You learn something every day...if you pay attention" Ray LeBlond