

School District of River Falls
Finance and Facilities Committee Meeting

Monday, September 9, 2024 - at 7:00 PM or immediately following the 6:00 PM Educational Program
Committee Meeting
District Office
852 E Division Street
River Falls, Wisconsin 54022

Finance and Facilities Committee members: Mike Miller (Chair), Bo Hirstein, & Alison Page

A quorum of the Board may be present for information-gathering purposes only.

Agendas can be viewed at <https://www.rfsd.k12.wi.us/district/school-board.cfm> or at
<https://meetings.boardbook.org/Public/Organization/1447>

1. CALL TO ORDER - 7:00 PM (or immediately after Education Program Committee Meeting)

2. MANNER OF PUBLIC NOTIFICATION OF MEETING

3. HEARING OF VISITORS OR DELEGATIONS

4. Facilities Projects Update **3**

Description: The Administration, Bray Architects, and Kraus Anderson will provide an update on the facilities projects.

Recommended Action: None, informational only.

5. CNC Router Purchase Approval **11**

Description: The Director of Finance & Facilities will recommend the purchase of a computer numerical controlled (CNC) router for the Renaissance Academy Technology Education Program.

Recommended Action: Approve the purchase of a CNC router.

6. 2024-25 Budget and Annual Meeting Booklet Draft **25**

Description: The Director of Finance & Facilities will provide a draft of the booklet for the Budget & Annual Meeting scheduled on September 16th at 6:00 pm in the HS Auditorium.

Recommended Action: None, informational only.

7. 2024-25 Revenue Limit Worksheet **45**

Description: The Director of Finance & Facilities will review the current draft of the 2024-25 Revenue Limit Worksheet.

Recommended Action: None, informational only.

8. 2024-25 Director of Finance & Facilities Goals **47**

Description: The Director of Finance & Facilities will review goals for 2024-25.

Recommended Action: None, informational only.

9. Board Policy Reviews - 611, 652, 653, 662.1 & 662.3 **48**

Description: The Director of Finance & Facilities will review updates to Board Policies 611, 652, 653, 662.1 & 662.3.

Recommended Action: Approve policy updates.

10. PROPOSED/SUGGESTED ITEMS FOR THE NEXT REGULAR AND FUTURE FINANCE & FACILITIES MEETING AGENDA(S)

Description: As always, committee members will be given the opportunity to suggest items for future committee and/or Board meeting agendas.

Recommended Action: As needed.

11. SCHEDULE NEXT FINANCE & FACILITIES COMMITTEE MEETING

Description: Upcoming committee meeting dates, times, and locations will be reviewed.

Recommended Action: Set the meeting schedule as follows:

Finance and Facilities Committee meeting, Monday, October 14, 2024, 7:00 p.m. (or immediately following Personnel)

The meeting will be held at the District Office, 852 E. Division Street.

12. ADJOURN



SCAN HERE

to learn more about the referendum projects

SCHOOL DISTRICT OF RIVER FALLS FACILITIES PROJECTS UPDATE

September 2024



WHAT'S NEW?

Since the successful referendum, River Falls has been working through initial planning steps. These steps include verifying the existing conditions of the schools, working through the design and construction schedules, and early engagement with some of the schools' staff.

To ensure proper design, the district has created a "Core Planning Team". This team is made up of administration members, a school board member, and partners from both Bray Architects and Kraus-Anderson Construction. During the design phase, the Core Planning team will continue to meet bi-weekly, engage with staff and routinely review budgets to ensure the projects are on track.

PLANNING & DESIGN UPDATE

The Core Planning Team has been focused on making sure the new Transportation Center, multipurpose room addition, and the security and building system upgrades align with the approved referendum. To assist with this process, we have had meetings with user groups and select staff along with our engineering partners to make sure all the necessary infrastructure upgrades are captured within the scope of work. The design team has been using the latest 3D technology to scan the schools to ensure this information is accurately captured.

WHAT'S NEXT?

- Continue Core Planning Team meetings
- Engineering coordination
- Work through interior design concepts
- Interior finish/material discussions
- Work with City of River Falls on local approvals

SCHEDULE

- Design completion – November 2024
- Tennis court construction starts – Fall 2024
- Bids due – early 2025
- Construction starts – Spring 2025



DEMOLITION AT NEW TRANSPORTATION CENTER SITE



DESIGN PRESENTATION AT BOARD COMMITTEE MEETING



RIVER FALLS HIGH SCHOOL - MULTIPURPOSE ROOM RENDERING



NEW TRANSPORTATION CENTER - TRAINING/BREAK ROOM RENDERING

EXTERIOR RENDERING | NEW TRANSPORTATION CENTER

FRONT



EXTERIOR RENDERING | NEW TRANSPORTATION CENTER

BACK



Project Phases Reminder

PRE-REFERENDUM

- Review Scope
- Confirm the Referendum Budget
- Layout the Bond Campaign with the School Board & Architect
- Develop Timeline of Activities & Referendum Strategies
- Strategize Successful Advocacy Efforts
- Develop Referendum Marketing Materials (Brochures, Flyers, etc.)
- Attend Public Meetings as a Resource to the District



Complete

PRECONSTRUCTION

- Cost & Schedule Management
 - Detailed Estimates Throughout All Phases
 - Value Management/Options
 - Constructability Review of Design Documents
 - Site Logistic Safety/ Disruption Avoidance Plan
 - Project Delivery Schedule
- Quality Control & Management Plan
 - Architectural Plan Review
 - Building Systems Review
 - Pre-Installation Guidance & Review
- MEP Systems Review
 - Review Mechanical & Electrical Systems
 - Life Cycle Costing Analysis

BID/AWARD

- Bid Packages
- Local Participation
- Investigate & Identify Long-Lead Items
- Conduct Pre-Award Conferences
- Monitor & Coordinate Submittal Schedule
- Sustainability

CONSTRUCTION

- Communication of Project Goals/Success Factors
- Provide/Monitor & Update Detailed Project Schedule
- Weekly Progress Meetings
- Weekly Risk Report
- Coordination of Contractors
- Disruption Avoidance
- Jobsite Safety Coordination
- Cost Management
- Quality Management System
- Coordination with City Inspectors

POST-CONSTRUCTION

- Commitment to Project Closeout
- Commissioning
- Coordinate Move-In
- Warranty Enforcement
- 11-Month Walkthrough
- Commitment to the Long-Term Relationship

Reminder on Bidding / Procurement Process

Public Bidding

- Detailed work scopes for individual trade contractors to bid (fair competition)
- Write front-end bid specifications for safety, schedule, quality, and control document requirements
- Investigate and identify long lead items
- Interview low-responsible bidders
- Collect & monitor all bonds, insurances, shop drawings and submittals
- Focus on local participation**
 - Include locally owned companies
 - Includes trade contractors that have employees who live in area

Example bid form & tabulation sheet

		KRAUS-ANDERSON Construction Company				MAPS Dakota Meadows Middle School		BID TABULATIONS	
		OWNER: Mankato Area Public Schools						12/20/2023	
		ARCHITECT: LSE Architects						WS 09-C Ceilings & Acoustical Treatments	
	BIDDER	BIDDER	BIDDER	BIDDER	BIDDER	BIDDER	BIDDER	BIDDER	BIDDER
	Janning's Acoustics, Inc.	Palmer-Soderberg, Inc.	Twin City Acoustics, Inc.	Sonus Interiors, Inc.	Architectural Sales of Minnesota, Inc.	Acoustics Associates, Inc.			
ADDENDA REC'D.	1 - 3	1 - 3	1 - 3	1 - 3	1 - 3	1 - 3			
BID SECURITY		Bid Bond	CNA Surety	Bid Bond	Bid Bond	Bid Bond			
BASE BID	\$149,350.00	\$208,213.00	\$226,820.00	\$331,000.00	\$338,325.00	\$457,000.00			
COMBINED BASE BID									
	Bid Withdrawn								

WS	Low Bid Contractor	Bid Amount			
01-J	Prime Construction	\$ 44,798			
03-A	Evenson Concrete Systems	\$ 794,000			
03-B	Wells Concrete	\$ 2,003,400	3-A/4-A	\$ 1,948,099	Axel Ohman Combined
04-A	J&K Masonry	\$ 830,000			
05-A	Construction Systems	\$ 362,583	Second low		
05-B	KMH Erectors	\$ 207,000			
06-A	Ebert	\$ 517,700			
07-F	Schwickerts	\$ 505,320			
07-H	Jackson & Associates	\$ 1,067,000			
08-A	Kendell	\$ 384,766			
08-D	No Bid	\$ 25,000			
08-F	Ford Metro	\$ 470,400			
09-A	Pietsch	\$ 359,615			
09-B	Commercial Flooring Services	\$ 348,722			
09-C	Palmer Soderberg	\$ 208,213			
09-D	Rickway	\$ 100,800			
09-F	H2I	\$ 91,160			
09-G	Wisconsin Terrazzo & Tile	\$ 191,720			
09-K	Admiral Coatings	\$ 318,980			
10-J	H&B Specialized Products	\$ 53,699	H2I	\$ 57,000	
11-K	H2I	\$ 94,000	H&B	\$ 97,600	
12-C	No Bid	\$ 180,000			
12-H	SAAFE	\$ 68,670			
13-A	Aqua Logic	\$ 3,215,000			
14-B	TK Elevator Corp	\$ 119,500			
21-A	Dynamic Fire Protection	\$ 114,850			
23-B	Javens Mechanical	\$ 4,471,500			
26-A	R&K Electrical	\$ 1,149,625	McMartin	\$ 1,334,000	
31-A	Dulas Excavating	\$ 519,500			
32-A	WW Blacktopping	\$ 84,677	Neilson (Combined)	\$ 229,000	32-A/32-B
32-B	Evenson Concrete Systems	\$ 75,000	Evenson	\$ 75,000	
32-F	Autumn Ridge Landscaping	\$ 59,596			
		\$ 19,036,794	\$ 22,230,372	\$ 3,193,578	Variance
			Estimate		

Tennis Court Bid Update

- There where five work scopes
 - Earthwork / Excavation
 - Paving
 - Electrical
 - Tennis Court Surface
 - Fence
- Total of low competitive bids (construction only, not including permits, insurances, testing, contingencies, professional fees)
 - **\$934,186**
 - Bids are 1% under budget
- Next Steps
 - Interviewing low bidding contractors
 - Collect shop drawings, bonds and insurances
 - Start earthwork late September
 - Phase 1 is to complete all earthwork, electrical and fencing by end of Fall
 - Phase 2 will be the top coat and striping in late spring 2025

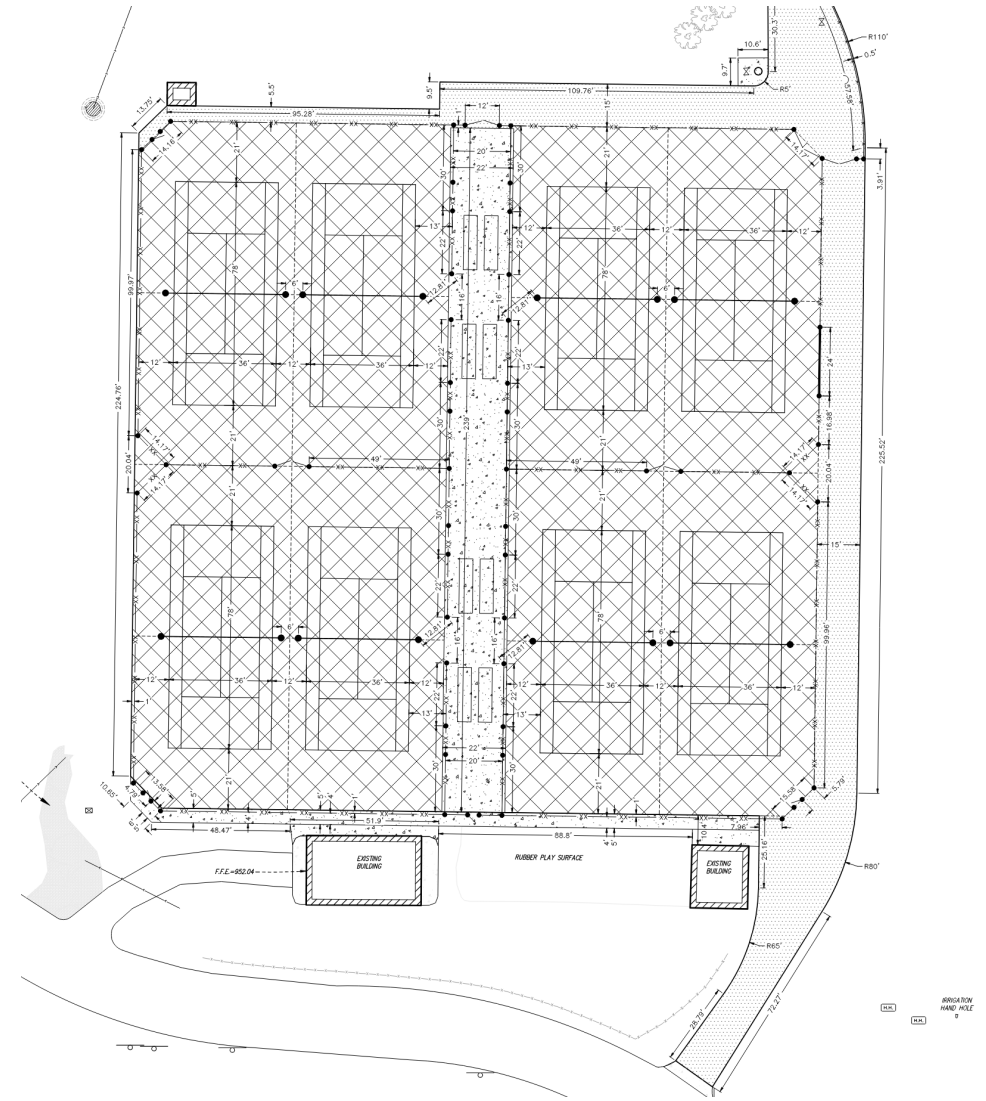

Master Schedule Reminder



Projects	2024												2025												2026											
	J	F	M	A	M	J	J	A	S	O	N	D	J	F	M	A	M	J	J	A	S	O	N	D	J	F	M	A	M	J	J	A	S	O	N	D
Transportation/Maintenance Center																																				
Design Phase					SD		DD				CD																									
Early Procurement for Steel & Precast																																				
Bidding																																				
Plan Review/Permits, Shop Drawings, Procurement																																				
Construction (5 months)																																				
	Permits & Mother Nature May Determine Start																																			
High School																																				
Design Phase					SD		DD				CD																									
Early Procurement for Steel & Precast																																				
Bidding																																				
Plan Review/Permits, Shop Drawings, Procurement																																				
Construction																																				
Tennis Courts Bidding																																				
Tennis Courts Construction																																				
	Permits & Mother Nature May Determine Start																																			
Meyer Middle School																																				
Design Phase																																				
Bidding																																				
Plan Review/Permits, Shop Drawings, Procurement																																				
Construction (5 months)																																				
	Permits & Mother Nature May Determine Start																																			
Rocky Branch																																				
Design Phase																																				
Bidding																																				
Plan Review/Permits, Shop Drawings, Procurement																																				
Construction (5 months)																																				
	Currently working on Design Development Estimates (50%+ Drawings) for Transportation and High School																																			
Westside Elementary																																				
Design Phase																																				
Bidding																																				
Plan Review/Permits, Shop Drawings, Procurement																																				
Construction (5 months)																																				



QUOTATION

Shop SABRE

• ROUTERS • PLASMA CUTTERS •



Prepared For River Falls Renaissance Academy

By Micah Dalluge
03 September 2024

QUOTE NO. 014581-R3



WELCOME

THANK YOU FOR EXPLORING SHOPSABRE CNC TECHNOLOGY, A PREMIUM NAME IN CNC TECHNOLOGY. SHOPSABRE CNC IS CONSTRUCTED FROM THE GROUND UP IN LAKEVILLE, MINNESOTA PROUDLY DISPLAYING THAT MADE IN THE U.S.A. LOGO. WITH EVERY COMPONENT USED CLOSELY MONITORED TO ENSURE EVERY SHOPSABRE CNC MACHINE WORKS FLAWLESSLY. OPERATING UNDER THE PHILOSOPHY THAT CUSTOMER SERVICE IS EVERYTHING. ALL SHOPSABRE MACHINES ARE TESTED FOR HOURS BEFORE THEY LEAVE TO ENSURE POWER, PRECISION, QUALITY, AND RELIABILITY.

WITH OVER 21+ YEARS OF EXPERIENCE AND OVER 6,000 CNC MACHINES IN OVER 35+ COUNTRIES AROUND THE WORLD, SHOPSABRE CNC HAS THE EXPERIENCE, REPUTATION, AND TECHNOLOGY TO GIVE YOU AN ADVANTAGE. THROUGHOUT THIS QUOTE WE ARE GOING TO SHOWCASE WHAT MAKES A SHOPSABRE CNC MACHINE SO UNIQUE AND WHY CHOOSING ANYTHING ELSE WOULD BE CONSIDERED SETTLING.

BELOW YOU WILL FIND SOME OF THE KEY FEATURES AND BENEFITS TO FURTHER VALIDATE WHY THE LINEUP OF SHOPSABRE CNC MACHINES ARE INDUSTRY LEADING. IF ANYTHING PRESENTED IS NOT 100% CLEAR OR YOU HAVE ANY QUESTIONS, I ASK THAT YOU REACH OUT TO ME PERSONALLY AND ALLOW ME TO THE OPPORTUNITY TO USE MY KNOWLEDGE OF THE TECHNOLOGY AND INDUSTRY TO HELP GUIDE, EDUCATE, AND SHOWCASE THE INCREDIBLE VALUE PACKED INTO THE PACKAGES WE OFFER HERE AT SHOPSABRE.

AS A CNC CONSULTANT, I AM NON-COMMISSION DRIVEN SO LET'S SPEND THE TIME NECESSARY TO MAKE SURE YOU ARE GETTING WHAT YOU NEED. IF YOU WANT TO DO ANY COMPARING OF OPTIONS, MACHINES, OR COMPANIES I AM HAPPY TO DO A COMPARATIVE ANALYSIS FOR YOUR BENEFIT.

THANK YOU FOR CONSIDERING SHOPSABRE CNC TECHNOLOGY!





FRAME CONSTRUCTION

SHOPSABRE CNC FRAMES ARE FEA ENGINEERED AND TESTED CONSTRUCTED FROM MASSIVE 4"X4" STRUCTURAL STEEL TUBES WHICH ARE WELDED FOR ADDED RIGIDITY. EACH RC SERIES FRAME COMES WITH 6 LEGS TO GIVING YOU MORE FLOOR CONTACT AND BETTER VIBRATION CONTROL. EACH LEG IS CROSS BRACED AND REINFORCED WITH A STEEL SIDE PANEL TO ADD ADDITIONAL STIFFNESS TO INCREASE THE RIGIDITY!

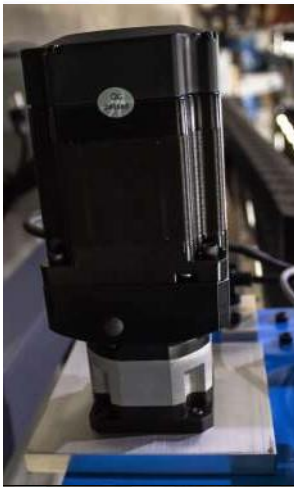

CLOSED LOOP MOTORS

SHOPSABRE RC MACHINES COME STANDARD WITH HEAVY DUTY INDUSTRIAL CLOSED LOOP MOTORS WITH ENCODERS FOR HIGH SPEEDS, HIGHER ACCURACY, AND LESS MAINTENANCE. SELF-MONITORING ENCODEER TECHNOLOGY PROVIDES EXTREME PERFORMANCE. CLOSED LOOP MOTORS ELIMINATE THE MISSED STEPS, LOSS OF ACCURACY, AND LOSS OF TORQUE.

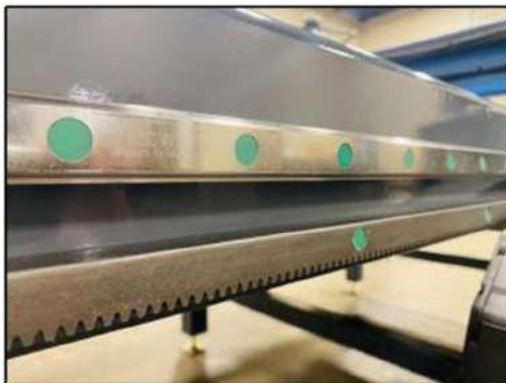

SHOPSABRE FLOATING DRIVE TECHNOLOGY

SHOPSABRE RC SERIES MACHINES ARE DRIVEN BY XY AXIS LARGE RACK AND PINION WITH SHOPSABRE EXCLUSIVE INVERTED "FLOATING DRIVE" GEAR ENGAGEMENT TECHNOLOGY. THIS TECHNOLOGY ALLOWS YOUR RACK AND PINION TO REDUCE DEBRIS CONTAMINATION WHILE SELF-ALIGNING FOR WEAR. THIS WILL INCREASE THE PERFORMANCE OF THE GEAR, INCREASE GEAR LIFE, AND REDUCE YOUR MAINTENANCE.



AERO SPACE MILLING TECHNOLOGY

SHOPSABRE CNC GANTRY SYSTEMS ARE RUN THROUGH SOME OF THE WORLD'S MOST ADVANCED PROCESSES TO ASSURE THEY ARE ACCURATE INCLUDING PRECISION MILLING OF CONTACT SURFACES FOR BEARING & RAIL PLACEMENT. A MACHINE CAN ONLY BE AS ACCURATE AS IT'S FOUNDATION SO THE FRAME ON A SHOPSABRE IS BUILT TO A TOLERANCE ABOVE THE COMPETITION.



SUPER Z TECHNOLOGY

SHOPSABRE RC MACHINES ARE AVAILABLE WITH THE SUPER Z TECHNOLOGY DESIGNED HERE AT SHOPSABRE CNC. THIS INCREASES YOUR Z AXIS TO 9" OF TRAVEL WHILE MAINTAINING INCREDIBLE RIGIDITY THANKS IN PART TO OUR FEA ENGINEERED STIFFENER TECHNOLOGY FOR TOOL PLATE STRENGTH AND OUR Z AXIS SERVO MOTOR CONTROL SYSTEM AND AIR BALANCER TECHNOLOGY GIVING YOU SOME OF THE QUICKEST TOOL CHANGES AND DRILLING CYCLES IN THE CLASS!

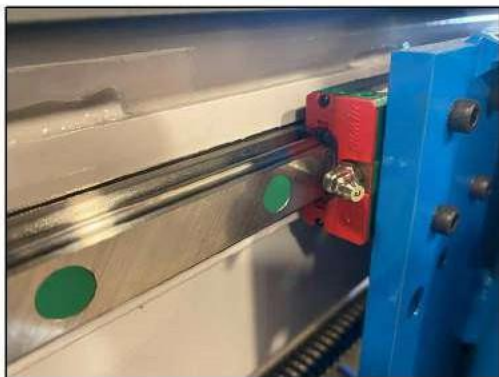

PRECISION LINEAR GUIDE TECHNOLOGY

SHOPSABRE CNC USES THE LATEST IN CNC BEARING TECHNOLOGY WITH 25MM LINEAR GUIDE RAILS AND BEARINGS ON ALL AXIS. EACH AXIS HAS 4 LARGE BODY QUAD BEARING ROLLERS WITH WIPERS TO INCREASE THE PERFORMANCE OF YOUR MACHINE. THESE BEARINGS ASSURE THE SURFACES STAY CLEAN WHILE INCREASING THE MACHINE RIGIDITY UNDER LOAD WHICH RESULTS IN INCREASED PERFORMANCE AND REDUCED MAINTENANCE IN LARGE PART DUE TO THE BALL BEARING TECHNOLOGY!



INDUSTRIAL PRECISION GANTRY

JUST LIKE OUR FRAMES, OUR GANTRY CONSTRUCTION IS CONSTRUCTED OF MASSIVE HEAVY WALL 4X10 TUBES THAT HAVE BEEN FEA DESIGNED AND TESTED TO PROVIDE HIGHER CUTTING FORCES AND LESS VIBRATION. THE BEARING SPACING ON OUR GANTRIES ARE LARGER THAN COMPETITION'S MACHINES TO BETTER HANDLE THE ROUTING FORCES WHILE INCREASING CUT SPEEDS.



INDUSTRIAL GANTRY UPRIGHTS

LIKE EVERYTHING ON A SHOPSABRE, THE GANTRY UPRIGHTS ARE ALSO MORE INDUSTRIAL. USING HIGH QUALITY NORTH AMERICAN STRUCTURAL STEEL THESE UPRIGHTS INCREASE THE BRIDGE CLEARANCE TO 8" STANDARD AND PROVIDE MORE RIGIDITY FOR BETTER CUTTING QUALITY AND VERSATILITY.

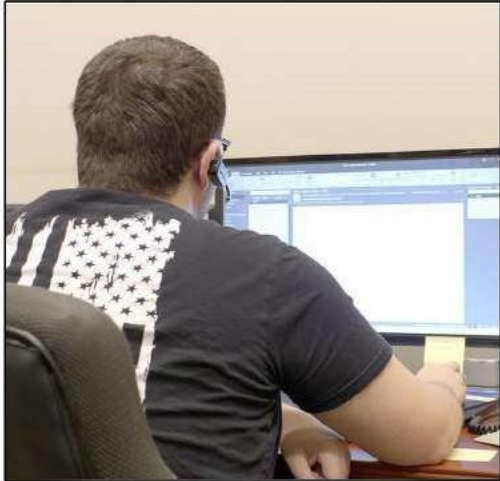

SHOPSABRE LIFETIME TECHNICAL SUPPORT

EVERY NEW SHOPSABRE CNC MACHINE COMES WITH LIFETIME TECHNICAL SUPPORT, AND WE ENCOURAGE YOU TO USE IT WHEN YOU NEED IT. WE STAND BY OUR MACHINES, AND WE STAND BY OUR SUPPORT. IN MANY CASES, OUR CUSTOMER SUPPORT TEAM CAN RESOLVE YOUR ISSUE REMOTELY VIA PHONE, EMAIL, OR INTERNET CONNECTIVITY. IF YOUR ISSUE REQUIRES ON-SITE SUPPORT, WE HAVE THE ABILITY TO SEND SOMEONE OVER AS QUICKLY AS POSSIBLE. PLEASE NOTE THAT ON-SITE SUPPORT MAY INCUR ADDITIONAL CHARGES, BUT WE WILL ALWAYS DO OUR BEST TO MINIMIZE ANY EXPENSES TO YOU.



TRAINING FOR LIFE

SHOPSABRE PROUDLY OFFERS YOU INCLUDED TRAINING FOR LIFE OF OWNERSHIP BECAUSE WE KNOW OUR MACHINE LOOKS BETTER WHEN YOU KNOW HOW TO USE IT PROPERLY. OUR SABRENATION UNIVERSITY INCLUDES VIDEOS CREATED BY OUR TEAM FEATURING ROUTERBOB GOING THROUGH TIPS, TRICKS, AND SOFTWARE RELATED ITEMS - WE ENCOURAGE OUR CLIENTS TO CHECK BACK REGULARLY AS WE UPLOAD NEW VIDEOS MONTHLY TO GIVE YOU ONGOING TRAINING ABILITIES. WE ALSO OFFER FREE REMOTE ASSISTANCE AND TRAINING USING STANDARD INTERNET AND A PHONE CALL WHICH CAN GIVE YOU THE ABILITY TO HIT THE GROUND RUNNING WITH FEWER HEADACHES AND MUCH LESS WAITING AROUND. NO SCHEDULING TRIPS, WAITING ON TECHNICIANS, OR DELAYING PROJECTS. FINALLY, IF YOU PREFER MORE OF A HANDS-ON APPROACH, WE OFFER FREE OF CHARGE ACCESS TO OUR SABRENATION ONE-DAY MACHINE OPERATOR BASIC TRAINING COURSE HELD EACH MONTH AT OUR BEAUTIFUL FACILITY IN LAKEVILLE, MINNESOTA!



AMERICAN MADE

HERE AT SHOPSABRE CNC, WE TAKE GREAT PRIDE IN THE FACT THAT ALL OF OUR MACHINES ARE TRULY BUILT AND SUPPORTED IN THE UNITED STATES OF AMERICA. UNFORTUNATELY, SOME CUSTOMERS DON'T UNDERSTAND THE VALUE OF AMERICAN BUILD UNTIL IT IS TOO LATE. MANY TIMES OTHERS ARE SIMPLY FOOLED INTO THINKING THAT CHINESE IMPORTS ARE A BETTER INVESTMENT BECAUSE THEY CAN COST LESS UP FRONT. 15

ShopSabre CNC
 21673 Cedar Ave.
 Lakeville, Minnesota, 55044, USA

Stapleton, Kyle
 River Falls Renaissance Academy
 1355 Sunshine Ave
 River Falls, WI, 54022
 715-425-7687
 Kyle.stapleton@rfsd.k12.wi.us



Proudly Manufactured, Assembled, and Supported in the USA!







QUOTE NO. 014581-R3
 DATE: 03 September 2024
 EXPIRATION DATE: 30 day(s) from Quoted Date Unless Stated Otherwise
 Warranty Information:

ShopSabre CNC Systems come with 1 year parts warranty. Also included with all New machine purchase is SabreNation Access which includes Life-Time Technical Assistance available by Telephone, Email, and On-Line Support. See Warranty Sheet for Details. Regarding Router Systems – No Warranty is implied for cut performance on Non-Ferrous Material such as but not limited to Aluminum, Brass, etc. Warranty is Void for cutting of any ferrous metal on CNC Router System.



SALESPERSON	P.O. #	PAYMENT TERMS	Financing Available
Micah Dalluge		First 50% at Time of Order; Remaining 50% Prior to Shipping	Shopsabre.com/financing
FOB: Origin		Accepted Payment: Wire Transfer, Check, or Credit Card – Credit Card Subject to 3.5% fee	

CNC ROUTER MACHINES

	Product Description	QTY	Line Total
9100-1014	 <p>ShopSabre RC-8 Router System</p> <ul style="list-style-type: none"> Fully Assembled Steel Welded Frame & Structural Steel Tubular Gantry. Limit Switches on X,Y,Z Axis with Auto Squaring and Boundary Alarms. Emergency Stop Switch. Planetary Gear Drives XY Axis with Heavy Duty Closed-Loop Motors with Encoder Technology on XYZ Axis. Oversized Rack and Pinion X & Dual Y Axis with ShopSabre Floating Drive Technology. High Precision Ball Screw Z Axis. Industrial 25MM Precision Linear Guide Rails & Bearings. ShopSabre WINCNC Industrial Controller Hardware & Software. ShopSabre Computer System - Full Size Desktop System with Solid State Hard Drive , 8GB Memory, 19" Flat Screen Monitor, Keyboard, Mouse. Vectric Vcarve Pro CAD/CAM Software. Machined MDF Table Top. 3.5HP Variable RPM Router with Machine Mounting Bracket. CNC Grade Power Cord for router with Automated Software Control for router On/Off by G-Code. Basic Dust Skirt W/ Quick Release Feature - 4" Outlet for Connecting to Dust Collector. Tool Measure Switch - Measures Tooling Height without Changing Z Height for Fast Tool Change. <p>ShopSabre SabreNation Support Included– Life-Time Technical Support via Phone, Email, and Remote Connectivity (Internet connection required)</p> <p>ShopSabre SabreNation Training Included – Access to ShopSabre digital SabreNation University training & videos, lifetime access for 2 People to attend ShopSabre Basic Training Course at ShopSabre CNC Facility in Lakeville Minnesota 55044 (Some limitations may exist, please call for details).</p>	1	
8100-1208	 <p>3.8KW 5HP HSD Auto Tool Changer Package - 10 Position (24,000RPM)</p> <p>Italian Built Industrial Electric Fan Cooled Auto Tool Changer Spindle Package - 3.8KW 5HP HSD ISO30 Package Includes 10 Position with Max Spindle RPM of 24,000RPM Linear Rack Style Tool Changer Package Includes: 10Qty - ER32 Collets (3- 1/4", 3- 3/8", and 3 - 1/2", 1- 1/8", 1 - 10MM, & 1- 3/4"), ISO30 Tool Holders (Cones), Compatible Tool Forks, Precision Mounted Fixed Linear Style Steel Tool Rack on rear of machine frame, Set of collet wrenches, Tool holder vice, Auto Spindle On/Off & Auto Spindle RPM control via G-Code or Manual over-ride, ShopSabre exclusive Super Z Technology with Air Balancer for Z Axis</p>	1	Option Included
8100-1217	 <p>Phenolic Table Top for RC8</p> <p>Phenolic Table Top for RC8 - These table tops are specifically engineered by ShopSabre using a high quality resin based material to be moisture resistant, humidity/temperature resistant, all while increasing machine performance, appearance, and functionality. Every ShopSabre Phenolic table is machines to the frame of the machine for added machine top accuracy. *Requires purchase of Spindle*</p>	1	Option Included

8100-1214	 <p>ShopSabre Single Phase F4 Vacuum System with 4 Zone Manifold ShopSabre Exclusive High CFM F4 Vacuum System with 4 Zone ShopSabre Vacuum Manifold produces a massive 570 CFM Open Flow with 10.69" HG. This Vacuum pump is the strongest single phase vacuum pump on the market designed with 4 independently controllable high CFM tangential bypass motors made proudly here in the U.S.A.! This Vacuum requires 220V, single Phase 30amp service. - On 5x10 machines Phenolic Table option Required, All-Star Gasket option recommended, and vacuum strategies necessary for best performance. F4 vacuum not compatible with equipment larger than 5x10 and designed for best performance on 4x8 and smaller sizes.</p>	1	Option Included
8100-1215	 <p>Material Height Touch Pad - Electronic Z Setter Material Height Touch Pad allows independent Z Axis Zero by using a integrated double touch for a calculated Z Zero independent from your tool length calibration. This device makes setting Z Zero easy, quick, and reliable.</p>	1	Option Included
8300-1000	 <p>1.25 Inch White Side non Insert Spoil Board Cutter 1.25 Inch White Side Traditional Non-Insert Style Spoil Board Cutter</p>	1	Option Included
8400-1009	 <p>Standard Bit Kit For Wood - Vortex Tool Standard Bit Kit For Wood - High Quality Vortex Tool Proudly Manufactured in the USA Kit Includes: - (2)1/4" x 7/8" DE DC FINISHER, (2) 3/8" x 7/8" DE MORT VIPER, 1/2" x 1 1/4" DE DC FINISHER, 1/4" x 7/8" DE MORTISE VIPER, 5MM X 70MM RH CT BRAD POINT, 1/4" x 7/8" DE UC FINISHER, 8MM X 70MM RH CT BRAD POINT</p>	1	Option Included
8100-1012	 <p>ShopSabre Wireless Hand-Held Controller Pendant with Jog Wheel ShopSabre Wireless Hand-Held Controller Pendant with Jog Wheel gives you the freedom of a remote with the professionalism of your CNC control. These Controller pendants have built in magnets so you can stick them to your machine or control stand without losing them. These controllers communicate directly to the provided dongle so you don't have to worry about interference with other controllers in your shop and they come with custom programmable buttons to give you all the function you need for your machine!</p>	1	Option Included
8400-1014	 <p>Maintenance Kit Maintenance Kit Includes ShopSabre recommended Grease (3 Tubes), required needle fitting, and a professional grease gun.</p>	1	Option Included
RC8 Entry Level Cabinet Package Discount		1	-11,211.00
 <p>ShopSabre CNC - Educational Discount ShopSabre CNC educational discount applies to freight expenses for lower 48 State Shipping on standard shipping at a \$2500 value. This offer is not able to be redeemed in cash value, cannot be combined with rush delivery expenses, special delivery requirements, or expenses/adjustments outside of the standard deliver expenses.</p>		1	0.00
		CNC Router Machine Subtotal: \$36,700.00	

COMPUTER SYSTEMS AND ACCESSORIES OPTIONS



Product Description	Add/Remove
 <p>8300-1013 USB Wireless for Computer Internet/Network Connectivity USB Wireless dongle for Computer Internet/Network Connectivity - This feature gives you the freedom to file transfer, network, or remote diagnose without the need to connect an ethernet cable. Note: High Speed Internet connection required for use of internet features.</p>	100.00
 <p>8100-0089 ShopSabre Rolling Control Stand ShopSabre Steel Rolling Control Stand (Not Enclosed) allows for an easy computer management system. This Industrial built rolling cart gives your operator a clean and convenient place to control your CNC machine from.</p>	605.00

8300-1055 **Machine Mounted Monitor, Keyboard, & Computer Stand** 360.00





ShopSabre Machine Mounted Monitor, Keyboard, & Computer Stand gives you a clean and professional controller management system. This adjustable stand frees up floor space while making it convenient for your operator to control the machine.



DUST COLLECTION OPTIONS

Product Description		Add/Remove
5500-1073	 <p>Oneida 3HP V-System 3000 SMART BOOST 55 Gal. Freestanding HEPA Cyclone Dust Collector Oneida 3HP V-System 3000 SMART BOOST 55 Gal. Freestanding HEPA Cyclone Dust Collector - Industrial 230V U.S. made fan motor provides ample CFM for up to 2 tools at once with 4"-6" dust ports. Includes RF remote control starter. High efficiency cyclone (over 99% separation) with smooth, compound molded surface. Ultra-quiet noise level with included sound filters - only 74 dBA at 10 feet. 35 or 55 gallon dust bin with quick-release lid and automatic fill level indicator. HEPA-certified filter media with non-stick membrane for easy cleaning. Durable, lightweight construction allows for quick and easy installation</p>	4,199.00
5500-1081	 <p>Oneida 5HP Dust Gorilla Pro 55 Gal. SMART Boost Dust Collector - Freestanding Oneida 5HP Dust Gorilla Pro 55 Gal. SMART Boost Dust Collector - Freestanding - High static air pressure system for CNC, sanding, and other fine dust applications. Equipped with SMART Boost® technology that doubles airflow performance through smaller 2.5" to 4" ports. Complete system includes heavy-gauge steel cyclone separator, U.S. made motor, modular cartridge filters, angle iron stand, 55 gallon dust bin, remote control, and more.</p>	4,649.00
5500-1080	 <p>Oneida 5HP 1ph High Vacuum Cyclone Dust Collector Oneida 5HP 1ph High Vacuum Cyclone Dust Collector - High static air pressure system for CNC, sanding, and other fine dust applications. Complete system includes heavy-gauge steel cyclone, U.S. made motor, spunbond cartridge filter, angle frame stand, 55 gallon dust bin, filter gauge, and more.</p>	5,775.00



TOOLING KITS OPTIONS

Product Description		Add/Remove
8400-1008	 <p>Standard Bit Kit for Signs - Vortex Tool Standard Bit Kit for Signs - High Quality Vortex Tool Proudly Manufactured in the USA - Kit Includes: - .020" TIP 30* SC ENGRAVING BIT, 1/8" x 1/2" DE UC BALLNOSE, 1/4" x 7/8" DE UC BALLNOSE, 1/4"x3/4" SE UC O'FLUTE, 1/2" x 5/8" 60* SC V-POINT BIT, 1/4" x 7/8" DE UC FINISHER, .040" TIP 30* SC ENGRAVING BIT, 1/8" x 3/8" BOTTOM SURFACING C, 1/4" x 7/8" DE MORTISE VIPER</p>	560.00
8400-1007	 <p>Standard Bit Kit for Plastic - Vortex Tool Standard Bit Kit for Plastic - High Quality Vortex Tool Proudly Manufactured in the USA - Kit Includes: - 1/4"x3/4" SE UC O'FLUTE, 1/4" x 3/4" DE O'FLUTE, 1/4" x 1 1/4" SE UC O'FLUTE, 1/4"x3/8" SE UC O'FLUTE, 1/8" x 1/2" DE O'FLUTE, 1/8"x1/2" SE UC O'FLUTE, 1/4"x3/4" SE DC O'FLUTE, 3/16" x 5/8" SE UC O'FLUTE, 1/4" x 1 1/4" SE DC O'FLUTE, 3/16" x 5/8" SE DC O'FLUTE, 1/8"x1/2" SE DC O'FLUTE, 1/4" x 3/8" DE O'FLUTE</p>	560.00

AUTOMATION SPECIFIC OPTIONS

Product Description		Add/Remove
5300-1015	6 Months of Mozaik Cabinet Software plus 2 Hours Online Software Setup and Training Provided by Mozaik 	600.00
5300-1014	6 Month Trial of KCD Cabinet Software Accelerate the design, pricing and building of your custom kitchens, baths, closets, and more with easy to use KCD Cabinet Software. + Software Setup, Training, and Support Provided by KCD - Software only available for Qualifying KCD Customers. 	0.00
5300-1013	6 Month of Cabinet Vision Cabinet Software provided by Cabinet Vision 	600.00

AIR COMPRESSOR AND DRYER OPTIONS

Product Description		Add/Remove
5500-1030	3-STAGE 20CFM FILTER PACK Includes a water separator , coalescing .01micron filter, oil vapor activated carbon filter and regulator all rated for 20 cfm max 	960.00
5500-1029	AC KRAD-25 - DRYER 25ACFM 	1,491.26
5500-1028	AC KRAD-40 - DRYER 40ACFM 	2,055.25

EXTENDED WARRANTY OPTIONS

Product Description		Add/Remove
9900-1004	SabreShield by ShopSabre 1 Year Extended Warranty ShopSabre Platinum Plan – Extends machine warranty 1 additional year with a \$350.00 deductible on all claims. All claims after 1 year factory warranty are subject to underwriting and extended warranty excludes coverage for damaged items, electrocution, collision, moisture, abuse, or lack of maintenance. Coverage does not cover labor unless otherwise determined necessary by ShopSabre Technical Support. Travel expenses not included with labor coverage. Customer will be responsible for freight costs.	3,500.00

VACUUM ACCESSORIES OPTIONS

	Product Description	Add/Remove
	5500-1096 ShopSabre All Star Vacuum Clamping Gasket Kit - 4x8 kit Turn your ShopSabre CNC Router vacuum system into an All Star superstar with parts holding power. Our All Star Vacuum Clamping gasket kit come with everything you'll need to have you vacuum table holding parts stronger than ever. Each kit includes Grid Gasket precision cut specific to your table's channel dimension ensuring an air-tight fit when sealing to your spoilboard. Also included is our patented Tile Gasket - a real game changer for holding parts on top of your work surface.	385.00

This is a quotation on the goods named, subject to the conditions noted below - ShopSabre Terms are Only Terms:															
Please Allow 4 to 18 Weeks for Delivery, This is not a guarantee on deliver time just an estimate based on averages as delivery may be delayed due to but not limited weather, parts availability, supply chain constraints, and/or shop production levels. ShopSabre recommends having electrician present for power installation - ShopSabre does not recommend accepting jobs for machine until installed as delays can happen. Client is responsible for all shipping and related costs, fees, etc. Consignee will need to have the necessary equipment to unload machine and accessories from delivery truck(s), ShopSabre does recommend a loading dock where possible for unloading of equipment, it will be the customers responsibility to communicate any special needs and requirements and any additional charges based on needs will be clients responsibility. Additionally, ShopSabre recommends 7500lb Forklift or larger with a minimum of 6-8-foot-long forks for offloading equipment. Note: drop ship items will ship separately from machine order - Ask for Details. In the event a truck cannot be offloaded or is delayed in offloading any additional costs that occurs will be chargeable to receiver and must be paid prior to support or training. ShopSabre is not responsible or liable for unloading/shipping coordination or expenses. This quote does NOT include any State/Local taxes, import duties/fees etc unless specifically listed and will be collected prior to shipping unless tax exemption can be provided. This machine is quoted to be received fully assembled. - CNC MACHINES CAN BE DANGEROUS - BUYER ACCEPTS LIABILITY AND RESPONSIBILITY FOR INSTALLATION OF SAFETY ITEMS SUCH AS BUT NOT LIMITED TO LIGHT CURTIANS, BARRIERS, and SAFETY MATS. - On Plasma Machines client MUST Provide Plasma Cutter for testing if not purchased from ShopSabre CNC at time of order - All Sales Are Final and Any Cancellations for ANY reason results in 35% Cancellation/Restocking Fee. To accept this quotation, ShopSabre Terms & Conditions + Warranty please sign here and return:	<table border="0"> <tr> <td>Subtotal:</td> <td style="text-align: right;">\$36,700.00</td> </tr> <tr> <td>Crating & Materials:</td> <td style="text-align: right;">450.00</td> </tr> <tr> <td>Estimated Shipping:</td> <td style="text-align: right;">0.00</td> </tr> <tr> <td>Total:</td> <td style="text-align: right;">\$37,150.00</td> </tr> <tr> <td>Required Deposit</td> <td style="text-align: right;">18,575.00</td> </tr> <tr> <td>Balance Prior to Shipping</td> <td style="text-align: right;">18,575.00</td> </tr> <tr> <td>Finance for As Low As</td> <td style="text-align: right;">\$668.70 /60</td> </tr> </table>	Subtotal:	\$36,700.00	Crating & Materials:	450.00	Estimated Shipping:	0.00	Total:	\$37,150.00	Required Deposit	18,575.00	Balance Prior to Shipping	18,575.00	Finance for As Low As	\$668.70 /60
Subtotal:	\$36,700.00														
Crating & Materials:	450.00														
Estimated Shipping:	0.00														
Total:	\$37,150.00														
Required Deposit	18,575.00														
Balance Prior to Shipping	18,575.00														
Finance for As Low As	\$668.70 /60														

***Quote Notes:**

Micah Dalluge



FAST. EASY. FINANCING.

THE ADVANTAGES OF WORKING WITH GENEVA CAPITAL :

TAX DEDUCTIONS – DEPENDING ON YOUR SPECIFIC PURCHASE, THERE MAY BE SOME BENEFICIAL WAYS TO SAVE ON YOUR YEARLY TAXES.

CASH FLOW – FINANCING OR LEASING A PIECE OF EQUIPMENT ALLOWS YOU TO KEEP YOUR CASH FLOW FOR OTHER PURCHASES.

DEFERRED PAYMENTS – YOU MAY QUALIFY FOR A DEFERRED PAYMENT ALLOWING YOU TO GET INTO EQUIPMENT BEFORE YOUR FIRST PAYMENT IS DUE.

100% FUNDING – MANY TIMES OUR LENDERS HAVE SOLUTIONS THAT INCLUDE 100% FUNDING SOLUTIONS

START UP BUSINESSES – LENDERS ARE OFTEN WILLING TO WORK WITH THOSE WHO MAY NOT ALREADY HAVE AN ESTABLISHED COMPANY.

SHOPSABRE CNC OFFERS MANY COMMERCIAL FINANCING AND LEASING OPTIONS THROUGH OUR TRUSTED THIRD-PARTY LENDERS. WE USE LENDERS WHO UNDERSTAND THE BENEFITS OF SHOPSABRE CNC EQUIPMENT, ALLOWING YOU TO RECEIVE BETTER RATES AND TERMS THAN OTHER COMPANIES AND ELIMINATING USING PERSONAL CREDIT AS COLLATERAL. SHOPSABRE CNC IS PROUD TO OFFER THESE OPTIONS TO OUR CLIENTS SO YOU CAN GET THE EQUIPMENT THAT'S RIGHT FOR YOU.

WE WORK TOGETHER TO MAKE A SEAMLESS AND EASY TRANSACTION ALLOWING YOU TO GET INTO THAT NEW PIECE OF EQUIPMENT QUICKLY.

MANY TIMES WE CAN GET YOU APPROVED IN AS LITTLE AS 2 HOURS! WE ARE GLAD TO WORK WITH YOUR OWN LENDER TOO!

SHOPSABRE RC8 SPECS:

- TABLE BED CUT AREA: 51" X 97" WITH ATC OR 55" X 97" WITHOUT ATC
- GANTRY CLEARANCE: 8" STANDARD
- MAXIMUM TRAVEL SPEEDS ON X & Y: 1000IPM STANDARD
- MAXIMUM TRAVEL SPEEDS ON Z: 500IPM
- Z TRAVEL: 9"
- MACHINE WEIGHT: 2100-2600 LBS
- MACHINE FOOT PRINT (INCLUDING GANTRY): 79" X 116" X 69" (78" WITH ATC)
- MACHINE STRUCTURE: STEEL TUBE FRAME- WELDED
- GANTRY STRUCTURE: LARGE TUBE STEEL WITH TUBE STEEL GANTRY UPRIGHTS
- DRIVE SYSTEM: X RACK AND PINION & DUAL Y AXIS RACK AND PINION WITH SHOPSABRE FLOATING DRIVE TECHNOLOGY - Z AXIS BALL SCREW
- BEARING SYSTEM: 25MM LINEAR GUIDE RAILS AND BEARINGS WITH QUAD ROLLER SETS AND TRIPLE SEAL BY THK/HIWIN
- CONTROLLER: SHOPSABRE WINCNC ADVANCED CONTROLLER
- PC SYSTEM: INCLUDED WITH SSD HARD DRIVE AND PCI CONTROLLER BOARD INSTALLED
- NETWORKABLE: YES
- PC TO PC CONNECTIVITY FOR DIAGNOSIS AND TRAINING: YES
- SOFTWARE: VECTRIC
- TECH SUPPORT: INCLUDED – LIFE-TIME
- CONTROLLER SOFTWARE UPDATES: INCLUDED
- MANUFACTURER: UNITED STATES – SHOPSABRE FACILITY –MINNESOTA
- FULLY ASSEMBLED• PRE-TESTED• LIFE-TIME TECH SUPPORT (PHONE/EMAIL/PC2PC)

F7,

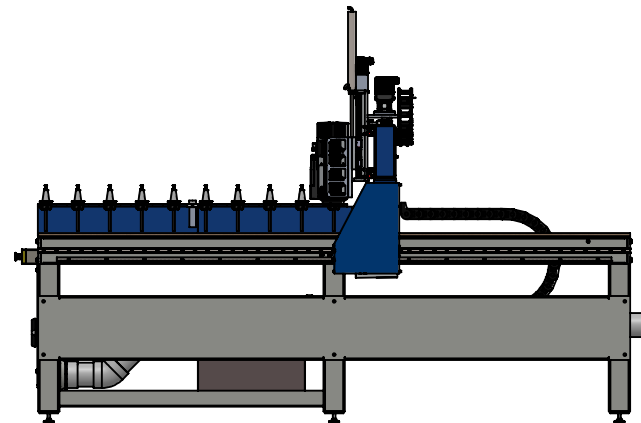
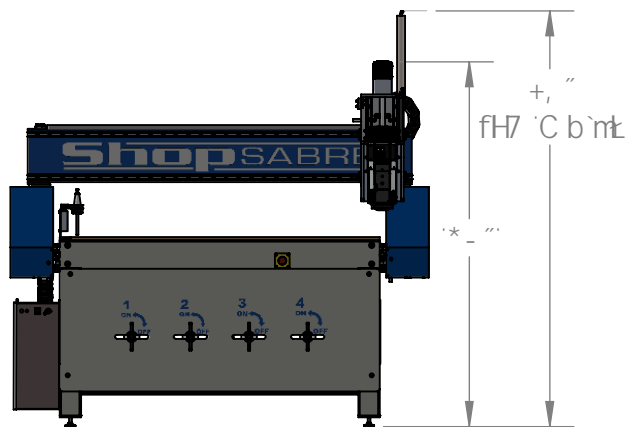
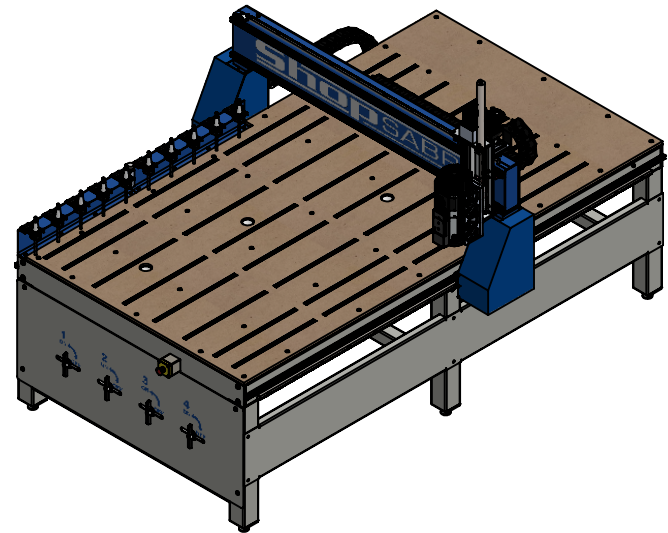
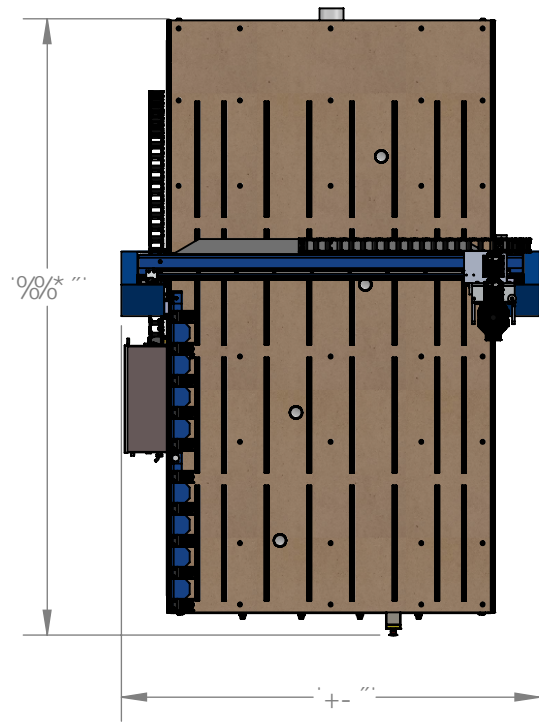

RC Series

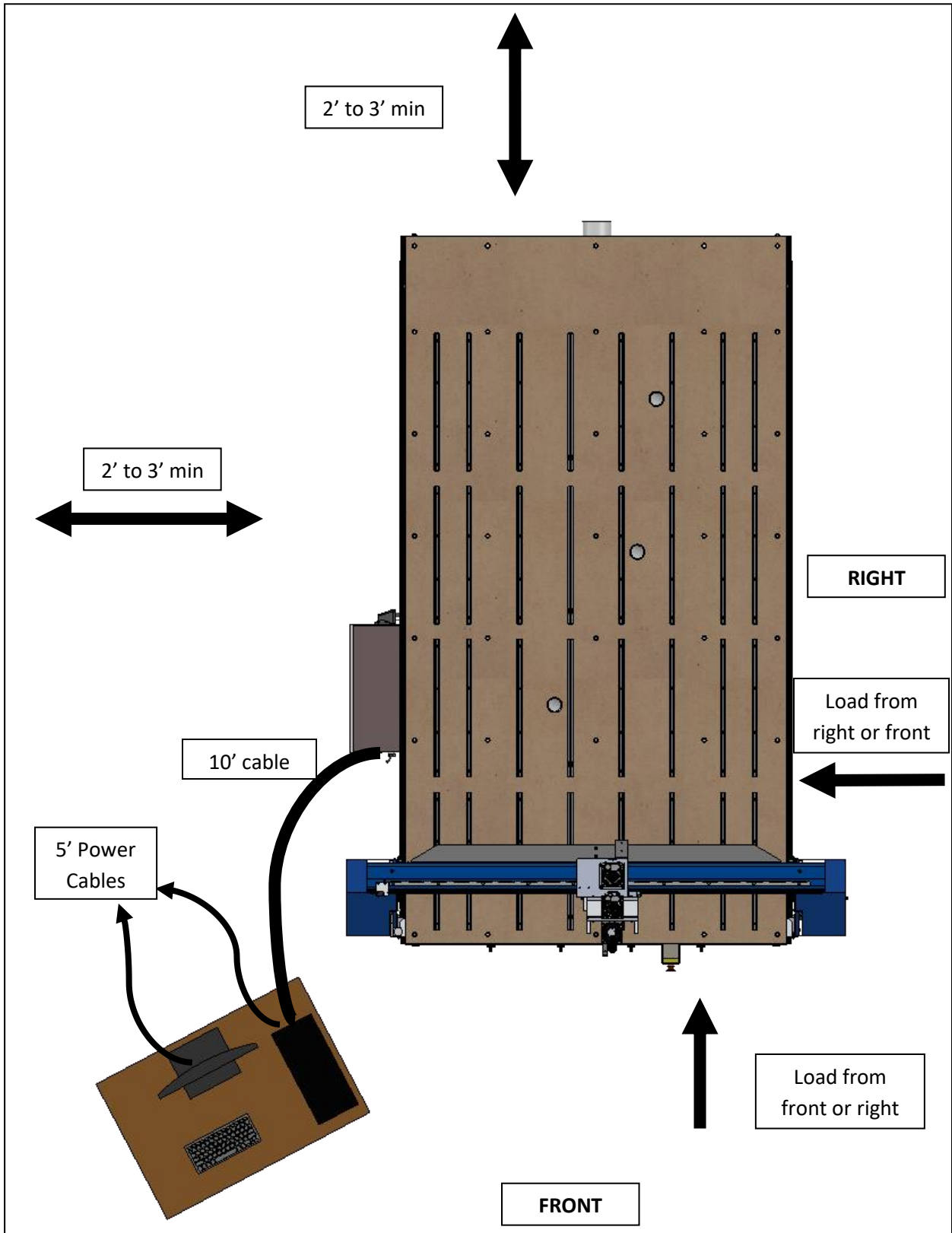



SCHOOL DISTRICT OF
River Falls

ANNUAL MEETING 2024

September 16, 2024

River Falls High School
Auditorium
818 Cemetery Rd
River Falls, WI 54022



WISCONSIN STATUTES

- 120.10 Powers of annual meeting.** The annual meeting of a common or union high school district may:
- (1) CHAIRPERSON AND CLERK.** Elect a chairperson and, in the absence of the school district clerk, elect a person to act as the clerk of the meeting.
 - (2) ADJOURNMENT.** Adjourn from time to time.
 - (3) SALARIES OF SCHOOL BOARD MEMBERS.** Vote annual salaries for school board members or an amount for each school board meeting the member actually attends.
 - (4) REIMBURSEMENT OF SCHOOL BOARD MEMBERS.** Authorize the payment of actual and necessary expenses of a school board member when traveling in the performance of duties and the reimbursement of a school board member for actual loss of earnings when duties require the school board member to be absent from regular employment.
 - (5) BUILDING SITES.** Designate sites for school district buildings and provide for the erection of suitable buildings or for the lease of suitable buildings for a period not exceeding 20 years with annual rentals fixed by the lease.
 - (5m) REAL ESTATE.** Authorize the school board to acquire, by purchase or condemnation under ch. [32](#), real estate and structures and facilities appurtenant to such real estate necessary for school district purposes.
 - (6) TAX FOR SITES, BUILDINGS AND MAINTENANCE.** Vote a tax to purchase or lease suitable sites for school buildings, to build, rent, lease or purchase and furnish, equip and maintain school district buildings. The tax may be spread over as many years as are required to pay any obligations approved or authorized at the annual meeting including rental payments due in future years under an authorized lease.
 - (7) TAX FOR TRANSPORTATION VEHICLES.** Vote a tax to purchase, operate and maintain transportation vehicles and to purchase liability insurance for such vehicles, and to finance contracts for the use and services of such vehicles.
 - (8) TAX FOR OPERATION.** Vote a tax for the operation of the schools of the school district.
 - (9) TAX FOR DEBTS.** Vote a tax necessary to discharge any debts or liabilities of the school district.
 - (10) SCHOOL DEBT SERVICE FUND.** Vote a tax to create a fund for the purpose of paying all current bonded indebtedness for capital expenditures. All money raised through taxation or otherwise collected pursuant to this subsection shall be deposited by the school district treasurer in a segregated fund. Such money shall not be used for any other purpose, except as provided by s. [67.11 \(1\)](#), or be transferred to any other fund except by authorization by a two-thirds majority vote of the total number of electors of the school district.
 - (10m) SCHOOL CAPITAL EXPANSION FUND.** Vote a tax to create a fund for the purpose of financing all current and future capital expenditures related to buildings and sites. All money raised through taxation or otherwise collected pursuant to this subsection shall be deposited by the school district treasurer in a segregated fund. Such money shall not be used for any other purpose or be transferred to any other fund except by authorization by a majority vote of the electors present at a subsequent annual meeting and only if notice that the issue would be on the agenda was included in the notice of the subsequent annual meeting under s. [120.08 \(1\) \(c\)](#).
 - (11) TAX FOR RECREATION AUTHORITY.** Vote a tax for the purposes specified in s. [66.0123](#).
 - (14) LEGAL PROCEEDINGS.** Direct and provide for the prosecution or defense of any action or proceedings in which the school district is interested.
 - (15) TEXTBOOKS.** Authorize the school board to furnish textbooks under conditions prescribed by the annual meeting or by the school board. The authorization shall continue in effect until revoked by a subsequent annual meeting.
 - (16) SCHOOL LUNCHES.** Direct the school board to furnish school lunches to the pupils of the school district and appropriate funds for that purpose.
 - (19) CONSOLIDATION OF HIGH SCHOOLS.** In a union high school district, vote to consolidate schools or to discontinue a school where more than one high school is operated by the school district.



SCHOOL DISTRICT OF RIVER FALLS

2024 ANNUAL MEETING AGENDA

Monday, September 16, 2024, 6 O'Clock p.m.
River Falls High School Auditorium
818 Cemetery Road

- 1. CALL TO ORDER - 6:00 PM IN THE RIVER FALLS HIGH SCHOOL AUDITORIUM**
- 2. INTRODUCTIONS**
- 3. ELECTION OF A CHAIR FOR THE ANNUAL MEETING**
- 4. PRESENTATION OF ANNUAL MEETING AGENDA**
- 5. APPOINTMENT OF A PARLIAMENTARIAN FOR THE ANNUAL MEETING**
- 6. APPOINTMENT OF A CLERK FOR THE ANNUAL MEETING (IF SCHOOL DISTRICT CLERK IS NOT PRESENT)**
- 7. STATE OF THE DISTRICT - SUPERINTENDENT DAVID BELL**
- 8. PRESENTATION AND HEARING OF THE 2024-2025 SCHOOL YEAR BUDGET**
- 9. NEW BUSINESS**
 - A. Approval of salaries of school board members for the election year (all members currently receive \$3,200 annually with the exception of the president, clerk, and treasurer who receive \$3,600 annually).
 - B. Approve Resolution to set the tax levy for 2024-2025.
 - C. Authorize the school board to set a date for the 2025 Annual Meeting at a later date.
 - D. Other matters as authorized by Wis.Stat.sec.120.20, if any.
- 10. ADJOURNMENT**



The Board of Education approved the 2022-27 Strategic Plan on June 20, 2022.

OUR MISSION

Inspire all students through challenging, meaningful, and engaging learning experiences, in a safe and collaborative environment.



OUR VALUES

STUDENTS FIRST - We center our policies, practices, and actions on doing what is best for all students.

PEOPLE MATTER - We value and respect our staff, and will find success by supporting their participation in collaborative learning communities.

EQUITY - We ensure the individual personal needs of every child are supported by high quality education/resources to pursue their unique potential.

RESPECT - We affirm the worth and dignity of all students, employees and community members. We foster a climate of civility, acceptance, and reasoned debate, embracing our diversity as a strength.

INTEGRITY - We ground our actions in character, honesty, responsibility, service, and compassion toward others.

EXCELLENCE - We embrace the continuous pursuit of improvement in school operations, services, and programs.

INNOVATION - We inspire and empower innovative thought and practice.

COMMUNICATION - We are accountable and transparent in order to maintain public trust.

GOAL 1:	GOAL 2:	GOAL 3:	GOAL 4:	GOAL 5:
Hold High Expectations for Student Learning	Provide a Safe, Welcoming, and Healthy School Environment	Attract, Retain, and Develop High Quality Staff	Provide Life Readiness Skills	Uphold Operational Excellence





BUDGET ADOPTION 2024 - 2025			
GENERAL FUND (FUND 10)	<u>Audited</u> 2022 - 2023	<u>Unaudited</u> 2023 - 2024	<u>Budget</u> 2024 - 2025
Beginning Fund Balance (Account 930 000)	12,546,023.68	14,242,445.16	14,586,997.18
Ending Fund Balance, Nonspendable (Acct. 935 000)	0	0	0
Ending Fund Balance, Restricted (Acct. 936 000)	499,959.70	55,109.19	22,000.00
Ending Fund Balance, Committed (Acct. 937 000)	0	0	0
Ending Fund Balance, Assigned (Acct. 938 000)	0	470,487.77	450,000.18
Ending Fund Balance, Unassigned (Acct. 939 000)	13,742,485.46	14,061,400.22	14,114,997.00
TOTAL ENDING FUND BALANCE (ACCT. 930 000)	14,242,445.16	14,586,997.18	14,586,997.18
REVENUES & OTHER FINANCING SOURCES			
100 Transfers-in	0	0	0
Local Sources			
210 Taxes	13,133,190.92	15,686,106.00	17,389,085.00
240 Payments for Services	16,599.41	13,233.68	18,000.00
260 Non-Capital Sales	1,944.05	2,164.21	1,000.00
270 School Activity Income	44,606.75	56,473.75	45,000.00
280 Interest on Investments	273,079.72	551,389.29	325,000.00
290 Other Revenue, Local Sources	298,222.02	286,289.23	282,000.00
Subtotal Local Sources	13,767,642.87	16,595,656.16	18,060,085.00
Other School Districts Within Wisconsin			
310 Transit of Aids	0	0	0
340 Payments for Services	1,623,447.53	1,645,459.20	1,671,299.00
380 Medical Service Reimbursements	0	0	0
390 Other Inter-district, Within Wisconsin	0	0	0
Subtotal Other School Districts within Wisconsin	1,623,447.53	1,645,459.20	1,671,299.00
Other School Districts Outside Wisconsin			
440 Payments for Services	0	0	0
490 Other Inter-district, Outside Wisconsin	0	0	0
Subtotal Other School Districts Outside Wisconsin	0	0	0
Intermediate Sources			
510 Transit of Aids	38,917.00	738	3,500.00
530 Payments for Services from CCDEB	0	0	0
540 Payments for Services from CESA	0	0	0
580 Medical Services Reimbursement	0	0	0



590 Other Intermediate Sources	0	0	0
Subtotal Intermediate Sources	38,917.00	738	3,500.00
State Sources			
610 State Aid -- Categorical	394,489.61	364,017.13	347,000.00
620 State Aid -- General	20,796,400.00	21,606,334.00	21,998,564.00
630 DPI Special Project Grants	106,687.64	196,170.11	76,000.00
640 Payments for Services	0	0	0
650 Student Achievement Guarantee in Education (SAGE Grant)	0	0	0
660 Other State Revenue Through Local Units	37,267.57	40,016.10	41,000.00
690 Other Revenue	2,864,627.82	2,895,404.82	2,800,461.00
Subtotal State Sources	24,199,472.64	25,101,942.16	25,263,025.00
Federal Sources			
710 Federal Aid - Categorical	20,434.00	24,211.35	20,352.00
720 Impact Aid	0	0	0
730 DPI Special Project Grants	2,129,851.20	209,673.43	77,731.00
750 IASA Grants	125,375.00	242,921.72	243,805.00
760 JTPA	0	0	0
770 Other Federal Revenue Through Local Units	0	0	0
780 Other Federal Revenue Through State	476,951.27	148,020.42	110,000.00
790 Other Federal Revenue - Direct	0	0	0
Subtotal Federal Sources	2,752,611.47	624,826.92	451,888.00
Other Financing Sources			
850 Reorganization Settlement	0	0	0
860 Compensation, Fixed Assets	15,812.25	3,013.60	5,000.00
870 Long-Term Obligations	0	0	0
Subtotal Other Financing Sources	15,812.25	3,013.60	5,000.00
Other Revenues			
960 Adjustments	15,546.80	21,272.37	0
970 Refund of Disbursement	103,032.62	133,118.07	95,000.00
980 Medical Service Reimbursement	0	0	0
990 Miscellaneous	24,345.00	78,874.79	5,000.00
Subtotal Other Revenues	142,924.42	233,265.23	100,000.00
TOTAL REVENUES & OTHER FINANCING SOURCES	42,540,828.18	44,204,901.27	45,554,797.00



EXPENDITURES & OTHER FINANCING USES			
Instruction			
110 000 Undifferentiated Curriculum	5,465,838.84	7,427,650.49	8,168,364.00
120 000 Regular Curriculum	12,277,237.39	11,173,735.20	11,750,428.00
130 000 Vocational Curriculum	876,580.99	924,393.77	887,605.00
140 000 Physical Curriculum	934,079.25	948,143.69	1,030,531.00
160 000 Co-Curricular Activities	705,466.60	814,905.68	812,876.00
170 000 Other Special Needs	238,942.29	298,516.37	315,077.00
Subtotal Instruction	20,498,145.36	21,587,345.20	22,964,881.00
Support Sources			
210 000 Pupil Services	1,269,286.75	1,413,618.21	1,365,747.00
220 000 Instructional Staff Services	1,143,528.05	1,025,584.30	1,042,876.00
230 000 General Administration	1,035,414.55	1,165,686.19	1,207,623.00
240 000 School Building Administration	2,616,136.87	2,771,555.70	2,886,383.00
250 000 Business Administration	8,348,564.27	7,511,154.21	8,855,040.00
260 000 Central Services	73,184.21	71,704.49	66,300.00
270 000 Insurance & Judgments	323,459.72	336,327.95	397,000.00
280 000 Debt Services	168,360.29	353,603.71	383,500.00
290 000 Other Support Services	349,035.20	468,168.34	317,143.00
Subtotal Support Sources	15,326,969.91	15,117,403.10	16,521,612.00
Non-Program Transactions			
410 000 Inter-fund Transfers	3,560,274.54	5,264,124.46	4,175,115.00
430 000 Instructional Service Payments	1,459,010.43	1,879,223.28	1,881,286.00
490 000 Other Non-Program Transactions	6.46	12,253.21	11,903.00
Subtotal Non-Program Transactions	5,019,291.43	7,155,600.95	6,068,304.00
TOTAL EXPENDITURES & OTHER FINANCING USES	40,844,406.70	43,860,349.25	45,554,797.00
SPECIAL PROJECT FUNDS (FUNDS 21, 23, 29)	<u>Audited</u>	<u>Unaudited</u>	<u>Budget</u>
	<u>2022 - 2023</u>	<u>2023 - 2024</u>	<u>2024 - 2025</u>
900 000 Beginning Fund Balance	358,455.65	379,740.58	456,069.41
900 000 Ending Fund Balance	379,740.58	456,069.41	456,069.41
REVENUES & OTHER FINANCING SOURCES	624,706.92	1,137,208.72,	1,015,000
100 000 Instruction	573,722.93	1,035,363.54	995,000
200 000 Support Services	20,811.42	18,816.35	20,000
400 000 Non-Program Transactions	8,887.64	6,700.00	0
TOTAL EXPENDITURES & OTHER FINANCING USES	603,421.99	1,060,879.89	1,015,000



SPECIAL EDUCATION FUND (FUND 27)	<u>Audited</u> 2022 - 2023	<u>Unaudited</u> 2023 - 2024	<u>Budget</u> 2024 - 2025
900 000 Beginning Fund Balance	0	0	0
900 000 Ending Fund Balance	0	0	0
REVENUES & OTHER FINANCING SOURCES			
100 Transfers-in	3,560,274.54	4,214,124.46	4,175,115.00
Local Sources			
240 Payments for Services	0	0	0
260 Non-Capital Sales	0	0	0
270 School Activity Income	0	0	0
290 Other Revenue, Local Sources	0	0	0
Subtotal Local Sources	0	0	0
Other School Districts Within Wisconsin			
310 Transit of Aids	0	0	0
340 Payments for Services	94,999.87	104,852.43	97,000.00
380 Medical Service Reimbursements	0	0	0
390 Other Inter-district, Within Wisconsin	0	0	0
Subtotal Other School Districts within Wisconsin	94,999.87	104,852.43	97,000.00
Other School Districts Outside Wisconsin			
440 Payments for Services	0	0	0
490 Other Inter-district, Outside Wisconsin	0	0	0
Subtotal Other School Districts Outside Wisconsin	0	0	0
Intermediate Sources			
510 Transit of Aids	0	0	0
530 Payments for Services from CCDEB	0	0	0
540 Payments for Services from CESA	0	0	0
580 Medical Services Reimbursement	0	0	0
590 Other Intermediate Sources	0	0	0
Subtotal Intermediate Sources	0	0	0
State Sources			
610 State Aid -- Categorical	1,644,521.21	1,685,277.00	1,930,501.00
620 State Aid -- General	0	0	0
630 DPI Special Project Grants	0	0	0
640 Payments for Services	0	0	0
650 Achievement Gap Reduction (AGR grant)	0	0	0
690 Other Revenue	20,063.61	15,277.08	20,000.00
Subtotal State Sources	1,664,584.82	1,700,554.08	1,950,501.00



Federal Sources			
710 Federal Aid - Categorical	0	0	0
730 DPI Special Project Grants	726,581.18	879,408.47	778,712.00
750 IASA Grants	0	0	0
760 JTPA	0	0	0
770 Other Federal Revenue Through Local Units	0	0	0
780 Other Federal Revenue Through State	106,582.02	85,736.81	100,000.00
790 Other Federal Revenue - Direct	0	0	0
Subtotal Federal Sources	833,163.20	965,145.28	878,712.00
Other Financing Sources			
860 Compensation, Fixed Assets	0	0	0
870 Long-Term Obligations	0	0	0
Subtotal Other Financing Sources	0	0	0
Other Revenues			
960 Adjustments	0	0	0
970 Refund of Disbursement	0	0	0
990 Miscellaneous	0	150	0
Subtotal Other Revenues	0	150	0
TOTAL REVENUES & OTHER FINANCING SOURCES	6,153,022.43	6,984,826.25	7,101,328.00
EXPENDITURES & OTHER FINANCING USES			
Instruction			
110 000 Undifferentiated Curriculum	0	0	0
120 000 Regular Curriculum	0	0	0
130 000 Vocational Curriculum	0	0	0
140 000 Physical Curriculum	0	0	0
150 000 Special Education Curriculum	4,797,700.58	5,470,207.81	5,551,234.00
160 000 Co-Curricular Activities	0	0	0
170 000 Other Special Needs	0	0	0
Subtotal Instruction	4,797,700.58	5,470,207.81	5,551,234.00
Support Sources			
210 000 Pupil Services	852,105.56	924,440.10	944,617.00
220 000 Instructional Staff Services	313,451.74	304,400.36	343,933.00
230 000 General Administration	0	0	0
240 000 School Building Administration	0	0	0
250 000 Business Administration	119,555.65	227,514.14	170,071.00
260 000 Central Services	0	0	0



270 000 Insurance & Judgments	0	0	0
280 000 Debt Services	0	0	0
290 000 Other Support Services	0	0	0
Subtotal Support Sources	1,285,112.95	1,456,354.60	1,458,621.00
Non-Program Transactions			
410 000 Inter-fund Transfers	0	0	0
430 000 Instructional Service Payments	61,022.27	51,903.59	84,973.00
490 000 Other Non-Program Transactions	9,186.63	6,360.25	6,500.00
Subtotal Non-Program Transactions	70,208.90	58,263.84	91,473.00
TOTAL EXPENDITURES & OTHER FINANCING USES	6,153,022.43	6,984,826.25	7,101,328.00
DEBT SERVICE FUND (FUNDS 38, 39)	<u>Audited</u>	<u>Unaudited</u>	<u>Budget</u>
	<u>2022 - 2023</u>	<u>2023 - 2024</u>	<u>2024 - 2025</u>
900 000 Beginning Fund Balance	1,305,147.59	1,239,205.04	3,086,149.52
900 000 ENDING FUND BALANCES	1,239,205.04	3,086,149.52	878,242.52
TOTAL REVENUES & OTHER FINANCING SOURCES	7,047,571.53	7,455,547.48	7,923,636.00
281 000 Long-Term Capital Debt	7,113,514.08	5,608,603.00	10,131,543.00
282 000 Refinancing	0	0	0
283 000 Operational Debt	0	0	0
285 000 Post Employment Benefit Debt	0	0	0
289 000 Other Long-Term General Obligation Debt	0	0	0
400 000 Non-Program Transactions	0	0	0
TOTAL EXPENDITURES & OTHER FINANCING USES	7,113,514.08	5,608,603.00	10,131,543.00
842 000 INDEBTEDNESS, END OF YEAR	48,990,000	73,505,000	66,445,000
CAPITAL PROJECTS FUND (FUNDS 41, 46, 48, 49)	<u>Audited</u>	<u>Unaudited</u>	<u>Budget</u>
	<u>2022 - 2023</u>	<u>2023 - 2024</u>	<u>2024 - 2025</u>
900 000 Beginning Fund Balance	656,004.00	667,262.97	28,863,594.45
900 000 Ending Fund Balance	667,262.97	28,863,594.45	18,170,594.45
TOTAL REVENUES & OTHER FINANCING SOURCES	11,258.97	29,111,606.67	855,000.00
100 000 Instructional Services	0	0	0
200 000 Support Services	0	915,275.19	11,548,000.00
300 000 Community Services	0	0	0
400 000 Non-Program Transactions	0	0	0
TOTAL EXPENDITURES & OTHER FINANCING USES	0	915,275.19	11,548,000.00



FOOD SERVICE FUND (FUND 50)	<u>Audited</u> 2022 - 2023	<u>Unaudited</u> 2023 - 2024	<u>Budget</u> 2024 - 2025
900 000 Beginning Fund Balance	713,364.83	689,730.52	400,206.68
900 000 ENDING FUND BALANCE	689,730.52	400,206.68	400,206.68
TOTAL REVENUES & OTHER FINANCING SOURCES	2,100,551.84	1,920,596.44	1,991,735.00
200 000 Support Services	2,124,186.15	2,210,120.28	1,991,735.00
400 000 Non-Program Transactions	0	0	0
TOTAL EXPENDITURES & OTHER FINANCING USES	2,124,186.15	2,210,120.28	1,991,735.00
COMMUNITY SERVICE FUND (FUND 80)	<u>Audited</u> 2022 - 2023	<u>Unaudited</u> 2023 - 2024	<u>Budget</u> 2024 - 2025
900 000 Beginning Fund Balance	135,990.96	200,130.37	177,711.47
900 000 ENDING FUND BALANCE	200,130.37	177,711.47	182,933.47
TOTAL REVENUES & OTHER FINANCING SOURCES	1,052,553.54	1,140,259.99	1,175,000.00
200 000 Support Services	54,620.86	57,724.55	60,700.00
300 000 Community Services	933,793.27	1,104,954.34	1,109,078.00
400 000 Non-Program Transactions	0	0	0
TOTAL EXPENDITURES & OTHER FINANCING USES	988,414.13	1,162,678.89	1,169,778.00
PROPOSED PROPERTY TAX LEVY 2024-25			
Levy Summary	<u>Audited</u> 2022 - 2023	<u>Unaudited</u> 2023 - 2024	<u>Budget</u> 2024 - 2025
General Fund	\$13,118,056	\$15,672,122	\$17,376,085
Referendum Debt Service Fund	\$7,014,405	\$6,966,725	\$7,908,636
Community Service Fund	\$220,000	\$220,000	\$220,000
Prior Year Levy Chargeback	\$542	\$0	\$11,903
TOTAL SCHOOL LEVY	\$20,353,003	\$22,858,847	\$25,516,624
PERCENTAGE INCREASE -- TOTAL LEVY FROM PRIOR YEAR		12.31%	11.63%

Other Post Retirement Benefits - OPEB

The District established a trust fund in 2007-08 which is used to account for other post employment benefits. The activity from the trust fund is summarized below:

<u>7/1/2023 Beginning Balance</u>	<u>2023-24 Disbursements</u>	<u>6/30/2024 Ending Balance</u>
\$4,841,059.66	\$603,862.50	\$4,619,399.88

The rate of return on the trust averaged 1.65% during the 2023-24 fiscal year. The investments are managed by MidAmerica Administrative & Retirement Solutions, Inc.



Revenue Sources 2024-25* - General & Special Ed Funds

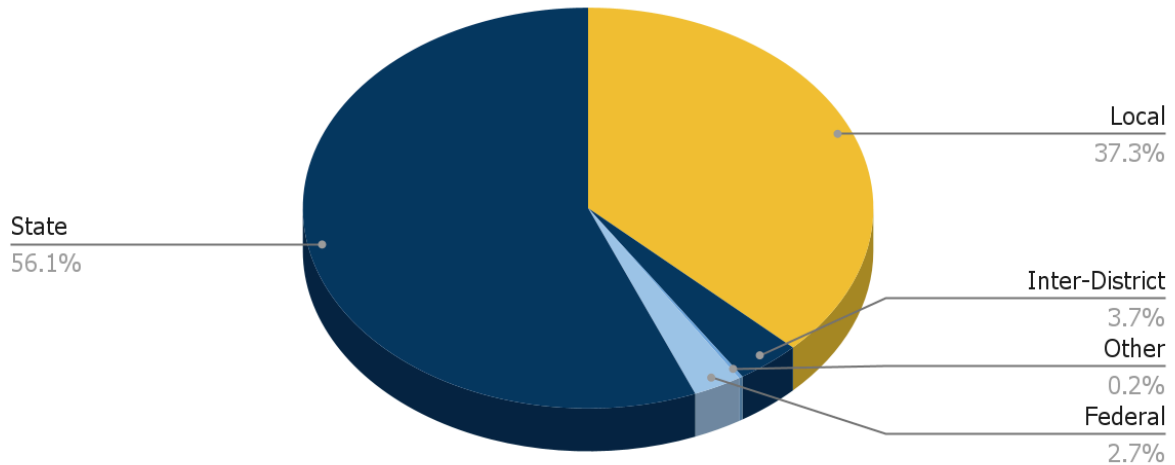

Not including \$4.1 million transfer from General Fund to Special Ed Fund

Expense Objects 2024-25* - General & Special Ed Funds

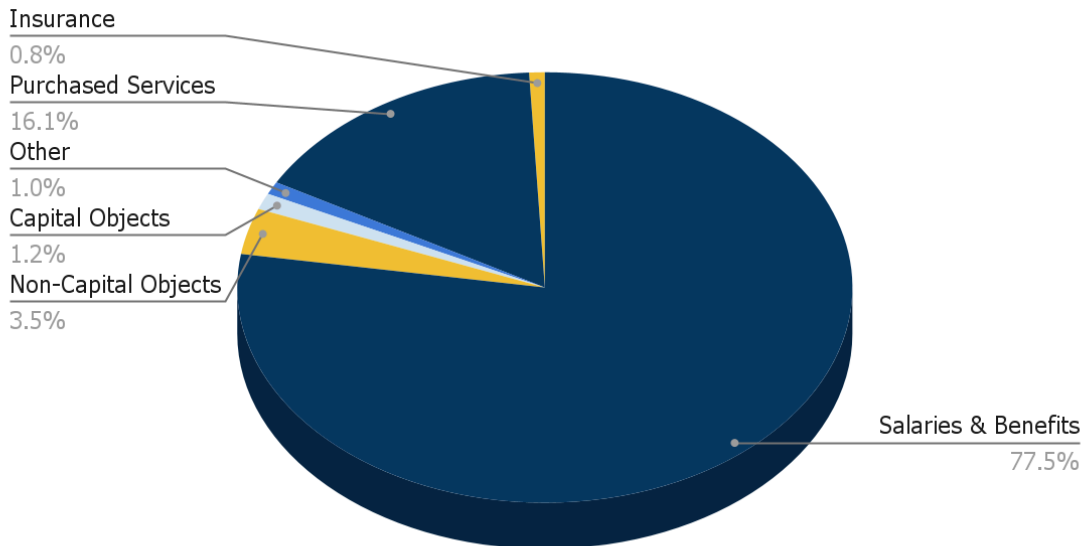



School District of River Falls - Mill Rate History

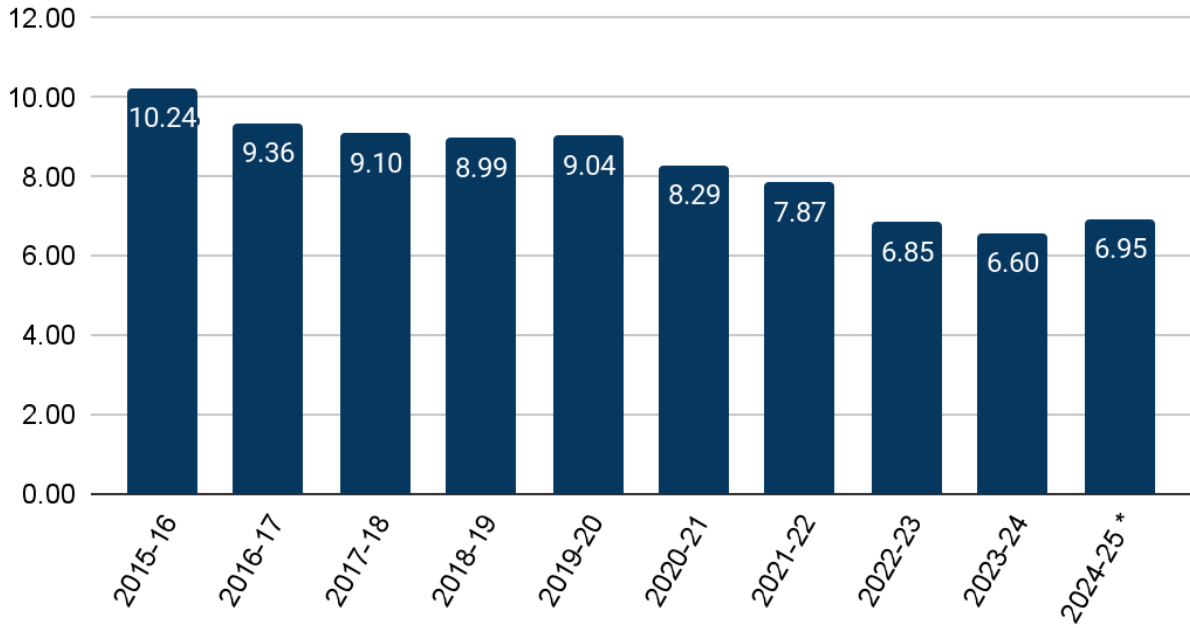

2023-24 Mill Rates - Area Districts

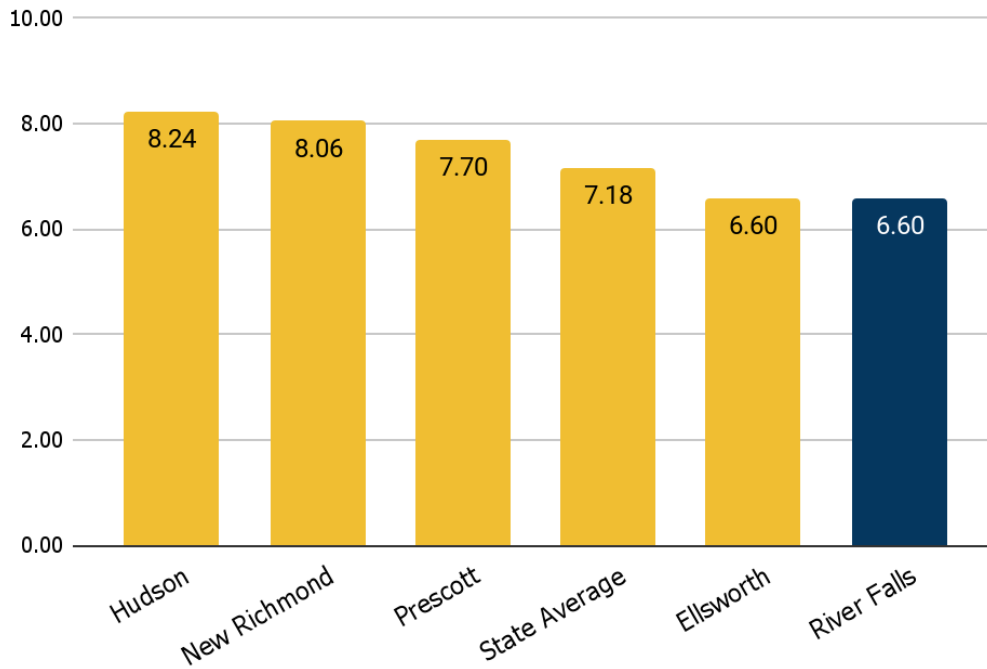



SCHOOL DISTRICT OF RIVER FALLS				
2024 Estimated District Levies & Valuations*				
	Municipality	Equalized Valuation* (TID OUT)	Percent of Tax Levy	2024-25 Levy*
Pierce Co.	City of River Falls	1,098,781,000	29.93%	\$7,637,900
	Town of Clifton	299,513,829	8.16%	\$2,081,995
	Town of Martell	84,231,770	2.29%	\$585,516
	Town of River Falls	411,522,643	11.21%	\$2,860,596
St.Croix Co.	City of River Falls	637,560,600	17.37%	\$4,431,842
	Town of Kinnickinnic	357,539,604	9.74%	\$2,485,347
	Town of Pleasant Valley	23,998,683	0.65%	\$166,821
	Town of Rush River	400,358	0.01%	\$2,783
	Town of Troy	757,248,745	20.63%	\$5,263,824
	TOTALS	3,670,797,232	100.00%	\$25,516,624
	General Fund Levy (Fund 10)			\$17,376,085
	General Fund Levy/Mill Rate (Fund 10)			4.734
	Debt Service Fund Levy (Fund 39)			\$7,908,636
	Debt Service Fund Levy/Mill Rate (Fund 39)			2.154
	Community Fund (Fund 80)			\$220,000
	Community Fund Levy/Mill Rate (Fund 80)			0.060
	Chargebacks Levy			\$11,903.00
	Chargebacks Mill Rate (Fund 10)			0.003
	Total School Levy			\$25,516,624
	Net Levy/Mill Rate			6.95
*Estimate is based on the Wisconsin Department of Revenue 2024 Statement of Changes in Equalized Values. School District Equalized Values will be certified October 1st, 2024.				



SCHOOL DISTRICT OF RIVER FALLS

2024 ANNUAL MEETING

Monday, September 16, 2024, 6 O’Clock p.m.
River Falls High School Auditorium
818 Cemetery Road

MOTION TO APPROVE BOARD SALARIES

Move to set Board members’ annual salaries at \$_____ per Board member with the president, clerk and treasurer salaries at \$_____ for the 2024-2025 election year.

Motion made by: _____

Seconded by: _____

RESOLUTION TO SET THE TAX LEVY FOR 2024-2025

BE IT RESOLVED that there be and hereby is levied upon the taxable property of the district for the purpose of defraying the expenses of the district for the school year ending June 30, 2025, a tax in the sum of \$_____.

Motion made by: _____

Seconded by: _____

RESOLUTION TO SCHEDULE THE 2025 ANNUAL MEETING

BE IT RESOLVED that in the 2024-25 school year the School District of River Falls be authorized to set the 2025 Annual Meeting at a later date..

Motion made by: _____

Seconded by: _____





August 2024				
M	T	W	Th	F
			1	2
5	6	7	8	9
12	13	14	15	16
19	20	21	22	23
26♦	27♦	28♦	29♦	30

October 2024				
M	T	W	Th	F
	1	2L	3	4
7♦	8	9	10	11
14	15	16L	17	18
21	22	23L	24	25
28	29	30L	31	

December 2024				
M	T	W	Th	F
2	3	4L	5	6
9	10	11L	12	13
16	17	18L	19	20
23	24	25	26	27
30	31			

February 2025				
M	T	W	Th	F
3	4	5L	6	7
10	11	12L	13	14
17♦*	18	19	20	21
24	25	26L	27	28

April 2025				
M	T	W	Th	F
	1	2L	3	4Q
7♦*	8	9	10	11
14	15	16L	17	18
21	22	23L	24	25
28	29	30L		

June 2025				
M	T	W	Th	F
2	3	4	5	6▼
9♦	10	11	12	13
16	17	18	19	20
23	24	25	26	27

September 2024				
M	T	W	Th	F
	3▲	4	5	6
9	10	11L	12	13
16	17	18L	19	20
23	24	25L	26	27
30				

November 2024				
M	T	W	Th	F
				1
4Q	5♦	6	7	8
11	12	13L	14	15
18	19	20L	21	22
25	26T	27	28	29

January 2025				
M	T	W	Th	F
		1	2	3
6	7	8L	9	10
13	14	15L	16	17
20*	21	22	23	24Q
27♦*	28	29	30	31

March 2025				
M	T	W	Th	F
3	4	5L	6	7T
10	11	12L	13	14
17	18	19	20	21
24	25	26L	27	28
31				

May 2025				
M	T	W	Th	F
			1	2
5	6	7L	8	9
12	13	14L	15	16♦*
19	20	21L	22	23
26	27	28	29	30

- ▲ First Student Day
- ▼ Last Student Day
- No school
- * Possible make-up days
- ♦ In-service Days
- L HS Late Start: 8:15am

AUGUST 2024

13	Renaissance GEDO 2 Orientation (5:30-7:30 pm)
20-21	New Teacher Orientation
26-29	Teacher In-Service
27	HS Parent Night Open House (5-8 pm)
27	REN Open House (5:30-7:30pm)
28	MMS Back-to-School Open House (12:30-7:30 pm)
28	Elementary Back-to-School Open House (3-6 pm)

SEPTEMBER

2	No School (Labor Day)
3	First Student Day of School (all schools, including RF4C)

OCTOBER

3	HS & Ren Parent/Teacher Conferences (4:30-7 pm)
7	No School for Grades K-8 (Teacher In-Service) Virtual Day for Grades 9-12

NOVEMBER

4	End of Quarter One (Secondary Level)
5	No School (Teacher In-Service)
7	MMS Parent-Teacher Conferences (3:15-7:30 pm)
7	Elementary Parent-Teacher Conferences (4-7:30 pm)
11	MMS Veterans Day Program (1 pm)
14	Elementary Parent-Teacher Conferences (4-7:30 pm)
26	End of Trimester One (Elementary Level)
27-29	No School (Thanksgiving Break)

DECEMBER

9	HS & Ren Parent/Teacher Conferences (4:30-7 pm)
23-31	No School (Winter Break)

JANUARY 2025

1	No School (Winter Break)
13	HS Course Registration/College Fair Night (5-8 pm)
20	No School (MLK Day)
24	End of Quarter Two (Secondary Level)
27	No School (Teacher In-Service)

FEBRUARY

13	MMS Parent-Teacher Conferences (3:15-7:30 pm)
17	No School for Grades K-8 (Teacher In-Service) Virtual Day for Grades 9-12
18	Elementary Parent-Teacher Conferences (4-7:30 pm)
20	Elementary Parent-Teacher Conferences (4-7:30 pm)
24	HS & Ren Parent/Teacher Conferences (4:30-7 pm)

MARCH

7	End of Trimester Two (Elementary Level)
	HS ACT Day for Juniors
11	(virtual day for Grades 9, 10, & 12)
17-21	No School (Spring Break)

APRIL

4	End of Quarter Three (Secondary Level)
7	No School (Teacher In-Service)

MAY

1	HS & Ren Parent/Teacher Conferences (4:30-7 pm)
15	Renaissance End of Year Celebration (6-8 pm)
16	No School (Teacher In-Service)
26	No School (Memorial Day)

JUNE

1	High School Graduation (1-3 pm)
6	Last Student Day of School
9	No School (Teacher In-Service)



2024 Annual Meeting

**DEPARTMENT OF PUBLIC INSTRUCTION
2024-25 REVENUE LIMIT WORKSHEET**

DISTRICT:	River Falls	▼	4893	▼
------------------	-------------	---	------	---

DATA AS OF 6/25/24

Line 1 Amount May Not Exceed (Line 11 - (Line 7B+Line 10)) of Final 23-24 Revenue Limit

2023-24 General Aid Certification (23-24 Line 12A, src 621)	+	21,606,334
2023-24 Hi Pov Aid (23-24 Line 12B, Src 628)	+	0
2023-24 Computer Aid Received (23-24 Line 12C, Src 691)	+	10,646
2023-24 Aid for Exempt Personal Property (23-24 Line 12D, Src 691)	+	37,606
2023-24 Fnd 10 Levy Cert (23-24 Line 14A, Levy 10 Src 211)	+	15,672,122
2023-24 Fnd 38 Levy Cert (23-24 Line 14B, Levy 38 Src 211)	+	0
2023-24 Fnd 41 Levy Cert (23-24 Line 14C, Levy 41 Src 211)	+	0
2023-24 Aid Penalty for Over Levy (23-24 FINAL Rev Lim, June 2024)	-	0
2023-24 Total Levy for All Levied Non-Recurring Exemptions*	-	15,919
NET 2024-25 Base Revenue Built from 2023-24 Data (Line 1)	=	37,310,789

*For the Non-Recurring Exemptions Levy Amount, enter actual amount for which district levied; (7B Hold Harmless, Non-Recurring Referenda, Declining Enrollment, Energy Efficiency Exemption, Refunded/Rescinded Taxes, Prior Year Open Enrollment Pupils, Reduction for Ineligible Fund 80 Expends, Other Adjustments, Private School Voucher Aid Deduction, Private School Special Needs Voucher Aid Deduction)

September & Summer FTE Membership Averages

Count Ch. 220 Inter-District Resident Transfer Pupils @ 75%.

Line 2: Base Avg:((21+.4ss)+(22+.4ss)+(23+.4ss)) / 3 = **3,387**

	2021	2022	2023
Summer FTE:	42	60	55
% (40,40,40)	17	24	22
Sept FTE:	3,365	3,386	3,346
New ICS - Independent	0.00	0.00	0.00
Charter Schools FTE			
Total FTE	3,382	3,410	3,368

Line 6: Curr Avg:((22+.4ss)+(23+.4ss)+(24+.4ss)) / 3 = **3,388**

	2022	2023	2024
Summer FTE:	60	55	55
% (40,40,40)	24	22	22
Sept FTE:	3,386	3,346	3,363
New ICS - Independent	0.00	0.00	0.00
Charter Schools FTE			
Total FTE	3,410	3,368	3,385

The Line 6 "Current Average" shown above is used for Revenue Limits. The average used for Per Pupil Aid does not include "New ICS - Independent Charter Schools FTE." The PPA average appears below after data is entered for 2024:

3,388

Line 10B: Declining Enrollment Exemption = **0**

Average FTE Loss (Line 2 - Line 6, if > 0) | **0**

X 1.00 =

X (Line 5, Maximum 2024-25 Revenue per Memb) = **0**

Non-Recurring Exemption Amount:

Fall 2024 Property Values

2024 TIF-Out Tax Apportionment Equalized Valuation **3,670,797,233**

CELL COLOR KEY: Auto-Calc DPI Data District-Entered

Worksheet is available at: <http://dpi.wi.gov/sfs/limits/worksheets/revenue>

**DEPARTMENT OF PUBLIC INSTRUCTION
2024-25 REVENUE LIMIT WORKSHEET**

2024-25 Revenue Limit Worksheet		
1. 2024-25 Base Revenue (Funds 10, 38, 41)	(from left)	37,310,789
2. Base Sept Membership Avg (2021+.4ss, 2022+.4ss, 2023+.4ss)/3	(from left)	3,387
3. 2024-25 Base Revenue Per Member (Ln 1 / Ln2)	(with cents)	11,015.88
4. 2024-25 Per Member Change (A+B)		325.00
2024-25 Low Revenue Ceiling per s.121.905(1):	11,000.00	
A. Allowed Per-Member Change for 2024-25	325.00	
B. Low Rev Incr ((Low Rev Ceiling-(3+4A))-4C) NOT<0	0.00	
C. Value of the CCDEB (2024-25 DPI Computed-CCDEB Dists only)	0.00	
5. 2024-25 Maximum Revenue / Member (Ln 3 + Ln 4)		11,340.88
6. Current Membership Avg (2022+.4ss, 2023+.4ss, 2024+.4ss)/3	(from left)	3,388
7. 2024-25 Rev Limit, No Exemptions (Ln7A + Ln 7B)	(rounded)	38,422,901
A. Max Rev/Memb x Cur Memb Avg (Ln 5 x Ln 6)	38,422,901	
B. Hold Harmless Non-Recurring Exemption	0	
8. Total 2024-25 Recurring Exemptions (A+B+C+D+E)	(rounded)	1,000,000
A. Prior Year Carryover	0	
B. Transfer of Service	0	
C. Transfer of Territory/Other Reorg (if negative, include sign)	0	
D. Federal Impact Aid Loss (2022-23 to 2023-24)	0	
E. Recurring Referenda to Exceed (If 2024-25 is first year)	1,000,000	
9. 2024-25 Limit with Recurring Exemptions (Ln 7 + Ln 8)		39,422,901
10. Total 2024-25 Non-Recurring Exemptions (A+B+C+D+E+F+G+H+I)		0
A. Non-Recurring Referenda to Exceed 2024-25 Limit	0	
B. Declining Enrollment Exemption for 2024-25 (from left)	0	
C. Energy Efficiency Net Exemption for 2024-25 (see pg 4 for details)	0	
D. Adjustment for Refunded or Rescinded Taxes, 2024-25	0	
E. Prior Year Open Enrollment (uncounted pupil[s])	0	
F. Reduction for Ineligible Fund 80 Expenditures (enter as negative)	0	
G. Other Adjustments (Fund 39 Bal Transfer)	0	
H. WPCP and RPCP Private School Voucher Aid Deduction	0	
I. SNSP Private School Voucher Aid Deduction	0	
11. 2024-25 Revenue Limit With All Exemptions (Ln 9 + Ln 10)		39,422,901
12. Total Aid to be Used in Computation (12A + 12B + 12C + 12D)		22,046,816
A. 2024-25 OCT 15 CERT OF GENERAL AID	21,998,564	
B. State Aid to High Poverty Districts (\$0 per 2023 Act 19)	0	
C. State Aid for Exempt Computers (Source 691)	10,646	
D. State Aid for Exempt Personal Property (Source 691)	37,606	
DISTRICTS MUST USE THE OCT 15 AID CERT WHEN SETTING THE DISTRICT LEVY.		
13. Allowable Limited Revenue: (Line 11 - Line 12) (10, 38, 41 Levies)		17,376,085
14. Total Limited Revenue To Be Used (A+B+C)	Not >line 13	17,376,085
Entries Required Below: Enter amnts needed by purpose and fund:		
A. Gen Operations: Fnd 10 Src 211	17,376,085	(Proposed Fund 10)
B. Non-Referendum Debt (inside limit) Fund 38 Src 211	0	(to Budget Rpt)
C. Capital Exp, Annual Meeting Approved: Fund 41 Src 211	0	(to Budget Rpt)
15. Total Revenue from Other Levies (A+B+C+D)		8,140,539
A. Referendum Approved Debt (Fund 39 Debt-Src 211)	7,908,636	
B. Community Services (Fund 80 Src 211)	220,000	(to Budget Rpt)
C. Prior Year Levy Chargeback for Uncollectible Taxes (Src 212)	11,903	(to Budget Rpt)
D. Other Levy Revenue - Milwaukee & Kenosha Only	0	(to Budget Rpt)
16. Total Fall, 2024 REPORTED All Fund Tax Levy (14A + 14B + 14C + 15)		25,516,624
Line 16 is the total levy to be apportioned in the PI-401.	Levy Rate =	0.00695125

Districts are responsible for the integrity of their revenue limit data & computation. Data appearing here reflects information submitted to DPI and is unaudited.



2024-25 Director of Finance & Facilities Goals

Director of Finance & Facilities Wildly Important Goal (WIG):

To successfully execute all capital referendum projects aligned to plan, within budget, on schedule, and with consistent, transparent communication to all stakeholders. - 5.1, 5.5

Lead Measures:

1. Regularly monitor project activities to ensure they align with the approved plan and timelines.
 - a. Bi-Weekly meetings with Core Planning Team
 - b. Weekly meetings with Buildings & Grounds Director for district-managed projects.
2. Proactively manage costs, reduce financial risks, and increase the likelihood of staying within budget.
 - a. Request early cost estimates to compare with budgets
 - b. Track project costs, overruns, change orders & contingencies
 - c. Monthly meetings with Architect and Construction Manager
3. Establish and implement a comprehensive communication strategy
 - a. Provide monthly updates to the Finance & Facilities Committee
 - b. Post updates to the district website and social media page

Other Priorities

- Add & streamline online payments to reduce cash handling by school employees - 1.1
- Eliminate paper timesheets for more accurate & timely payroll processing
- Add electronic time clock options to increase efficiency for employees
- Track and reduce response time for maintenance work orders for improved employee satisfaction - 3.6
- Create a process for submitting summer maintenance requests to set expectations and prioritize scheduling - 3.6



POLICY 611 FISCAL MANAGEMENT

The **School** Board of Education recognizes that prudent fiscal management is necessary to support the educational programs of the District. All District accounting practices should be performed in accordance with the law and to ensure efficient administration of the schools.

Administration and staff will prepare an annual operating budget, submit it to the **School** Board for approval and publish it in the **official newspaper** ~~River Falls Journal~~. The public will have the opportunity to learn about the District budget at the Annual Meeting/**Budget Hearing**. Monthly financial ~~reports~~ ~~statements~~ ~~shall~~ **will** be provided to the **School** Board. District expenditures will be approved by the **School** Board Treasurer with any budget changes submitted to the **School** Board for approval. Fund equity will be reported according to GASB Statement No. 54 standards. An annual financial audit ~~shall~~ **will** be conducted by a licensed accounting firm with the results reported to the **School** Board.

The district will maintain **a** fund balance necessary to avoid short term borrowing. Administration ~~shall~~ **will** invest available District funds in accordance with **policy 652 and** state law. Funds collected by student organizations ~~shall~~ **will** be accounted for and deposited into a depository approved annually by the **School** Board. Debt may be incurred as prescribed by law and approved by the **School** Board for the purpose of operating the District. ~~Employees and officers of the district that handle district funds shall be bonded.~~

A report of District equipment and fixed assets will be ~~inventoried at each building~~ **maintained and updated annually** ~~once per year~~. Inventory procedures ~~shall~~ **will** be developed by administration in accordance with law and mandated **governmental** accounting practices. An insurance program ~~shall~~ **will** be maintained to adequately protect District equipment, assets, and employees.

LEGAL REFERENCE: Wisconsin Statutes Sections 34, 65, 66, 67, 115, 118, 120, 121; GASB Statement No. 54

CROSS REFERENCE: 662.3 Fund Balance

DATE OF ADOPTION: May 21, 2007

REVISED: July 21, 2008, June 20, 2011, November 19, 2012, September 19, 2016, **XXXXXX XX, 2024**



POLICY 652 INVESTMENT INCOME

The **School** Board of Education authorizes a safe and sound investment program for the purpose of securing additional revenues in support of the District's education programs and aligned with the District's values. An investment program is viewed as a critical ingredient of sound fiscal management.

The primary objectives of the District's investment activities, in priority order, ~~shall~~ **will** be:

1. Safety – Safety of the principal is the foremost objective of the investment program. Investments ~~shall~~ **will** be made in a conservative manner that seeks to ensure the preservation of capital in the overall investment portfolio and maintains a positive bond rating.
2. Liquidity – The District's investment portfolio ~~shall~~ **will** remain sufficiently liquid to meet all operating requirements that might reasonably be anticipated.
3. Return on Investments – The District's investment portfolio ~~shall~~ **will** be designed with the objective of attaining a market rate of return throughout budgetary and economic cycles consistent with the safety of those monies and with the desired liquidity of the investments.

The **School** Board authorizes the Superintendent or Director of Finance to make proper and prudent investments of available monies from the funds of the District in accordance with provisions in this policy and as authorized by law. This responsibility includes an annual review and assessment of the District's investment program and recommendation for changes to this policy when applicable.

LEGAL REFERENCE: Wisconsin Statutes Sections 25.5, 66.0603

DATE OF ADOPTION: June 19, 2023

REVISED: **XXXXXX XX, 2024**



POLICY 653 GATE RECEIPTS AND ADMISSIONS

The Superintendent, or designee, ~~shall~~ **will** establish procedures to insure strict control and accounting for gate and admission receipts.

Adequate records ~~shall~~ **will** be maintained to allow for regular review and audit of supporting gate receipts and admissions.

LEGAL REFERENCE: Wisconsin Statute Section 120.13

DATE OF ADOPTION: July 17, 2017

REVISED: **XXXXXX XX, 2024**



POLICY 662.1 STUDENT ACTIVITY FUNDS MANAGEMENT

All student activity funds ~~shall~~ **will** be under the financial control of the **School** Board of Education and ~~shall~~ **will** be deposited in the appropriate District account in accordance with established procedures.

The Superintendent, or designee, ~~shall~~ **will** assign a faculty advisor for each class/club/activity who ~~shall~~ **will** be responsible to the building principal. The class/club/activity treasurer and faculty advisor(s) ~~shall~~ **will** be responsible to the building principal and to the Superintendent, or ~~his/her~~ designee, for documentation of all student activity monies.

Disbursements of student activity funds may be made only with the approval of the faculty advisor, building principal and the Superintendent, or designee. Proper documentation must accompany each request.

Complete records relating to student activity funds ~~shall~~ **will** be submitted to the Superintendent, or designee, for auditing at the end of each school year. The audit of student activity funds ~~shall~~ **will** be made at the same time as the annual audit of school district funds. The cost of such audit ~~shall~~ **will** be paid by the District.

No class, club or activity ~~shall~~ **will** be allowed to operate with a negative balance. Special exceptions may be made with the approval of the Superintendent, or designee, based on a reasonable expectation that such negative balance is a temporary condition that will be corrected by incoming receipts.

If an account has had no activity for 18 consecutive months, it may be considered inactive and closed by the Superintendent, or designee. Funds from inactive accounts ~~shall~~ **will** be transferred to the General Consolidated Account.

At the end of the school year, all balances ~~shall~~ **will** be carried over to the next school year with the exception of the graduating class treasury. The graduating class, after paying all its expenses, should designate before the end of the school year how any remaining balance ~~shall~~ **will** be allocated. Any funds which remain in a graduating class treasury at the end of the school year ~~shall~~ **will** automatically become part of the General Consolidated Account, unless special provisions are made.

LEGAL REFERENCE: Wisconsin Statute Sections **66.0607**, 120.14(1), **and 120.16(2) and Wisconsin Uniform Financial Accounting Requirements (WUFAR)**

CROSS REFERENCE: 374 Student Fund-Raising Activities

DATE OF ADOPTION: December 19, 1977

REVISED: September 16, 1991, May 15, 2005, **XXXXXX XX, 2024**



POLICY 662.3 FUND BALANCE

The **School** Board of Education recognizes that maintaining an adequate fund balance in the District's General Fund is essential to the financial stability of the District and sound fiscal management. The **School** Board also recognizes its responsibility to ensure that the District's fund balance resources are used properly and reported in accordance with applicable legal requirements and generally accepted accounting principles.

With these recognitions in mind, the **School** Board sets forth the following policy guidelines for the use and maintenance of fund balance resources in the District:

1. The District's fund balance resources ~~shall~~ **will** be reviewed annually to determine allocation between A) Non-spendable, B) Restricted, C) Committed, D) Assigned, and E) Unassigned fund balance account classifications. When multiple categories of fund balance are available for expenditure, the District will start with the most restricted category and spend those funds first before moving down to the next category with available funds.
- 2. To the extent that School Board action regarding any fund balance amounts under this policy constitutes a budget amendment under state law (i.e., a change in the amounts of the appropriations or the purposes for such appropriations as stated in an adopted school district budget), a two-thirds vote of the entire membership of the School Board will be required, and a legal notice of the action taken will be issued as required by law.**
3. A majority vote of the membership of the **School** Board ~~shall~~ **will** be required to commit or assign the use of the District's General Fund balance for a specific purpose, or to remove or change a previous fund balance commitment or assignment made by the **School** Board. **School** Board action to commit or assign fund balances ~~shall~~ **will** occur prior to the end of the fiscal year for which the commitment or an assignment is made (June 30) however, the actual amounts to be committed or assigned can be determined in the subsequent fiscal year period.
4. The District will maintain an unassigned fund balance in the General Fund that is equivalent to at least 25%, but not greater than 30% of the anticipated General Fund expenditure budget for the subsequent fiscal year. The purpose of maintaining this fund balance is to provide the District with adequate working capital sufficient to meet cash flow requirements, serve as a safeguard against unexpected expenses or unrealized revenues, and maintain a high credit rating for the District thus reducing District borrowing costs. Should the unaudited year-end fund balance in the General Fund be below the designated minimum, the **School** Board ~~shall~~ **will** develop a plan to replenish the fund balance in the General Fund to the designated minimum level.

LEGAL REFERENCE: GASB 54, **Wisconsin Statute sections 65.90(3), 65.90(5), 120.14, 120.18 and Wisconsin Uniform Financial Accounting Requirements (WUFAR)**

CROSS REFERENCE: 611 Fiscal Management

DATE OF ADOPTION: July 18, 2011

Suspended for the 2016-17 and 2017-18 school years with repayment of fund balance loan as outlined in the "High School Heating Pipe Funding Plan" by 12/31/2018.

REVISED: **XXXXXX XX, 2024**