



**MINOOKA COMMUNITY HIGH SCHOOL DISTRICT #111
COMMITTEE MEETING
WEDNESDAY, APRIL 13, 2022, 5:30 PM**

The Committee Meeting will be held at the
Academic Resource Center
301 South Wabena Avenue
Minooka, Illinois 60447

In order to make a public comment, please sign up 5 minutes prior to Roll Call. The public comment portion of the meeting will be in accordance with Policy 2:230. Please review said policy prior to the Board of Education Meeting.

AGENDA

1. **Call to Order**
2. **Roll Call**
3. **Public Comments**
4. **Discussion**
 - A. New Laws
 1. Covid Paid Administrative Leave
 2. Minority and Women Owned Vendors
 - B. Policy
 1. Parent/Student Handbook Revision - Second Reading 3
 2. Policy 8:80 - Donations from Foundation in the amount of \$5,025.95

Calculators (Special Education Department) \$505.95
Ipads (Math Department) \$4,050.00
Certified Strength and Conditioning Specialist Membership/Exam \$470.00
 - C. B & G
 1. Performance Contracting Bid Update
 2. Parking Lot Bids 10
 3. South Campus Aux Gym - Basketball Hoops 12
 4. Summer Projects
 - D. Finance
 1. Financial Reports
 - a. Monthly Financial Report 23
 - b. Payment of Bills/Total
 - c. Employee Payroll 30
 - d. Imprest Fund Report/Total 31
 - e. Activity Fund Report 32

f. Treasurer's Report (Cash/YTD - Exp/Rev)	38
2. Audit Bid	146
3. Furniture Bid	
4. TIF Update	
5. Amended Budget	
6. Leasing Levy Abatement Recommendation	147
7. Transportation Bus Lease	149
8. Kendall County Land Cash Resolution	150
9. Debt Service Fund Balance	
E. Personnel	
1. Superintendent Search	
2. Executive Session - to adjourn the meeting to executive session for discussion on matters related to the appointment, compensation, discipline, dismissal, employment and performance of specific employees of the district; collective bargaining and individual student discipline.	
3. Return to Open Session	
5. Announcements and Communications	
A. Upcoming Events (Prom April 29th, 2022 and Graduation May 15, 2022)	
6. Adjourn	

Minooka Community High School Handbook Revisions

2022-2023

Addition(s): Non-Discipline

1. E-Learning Learning Schedule
 - a. Class Schedule and Expectations

2. Excused Absences to now include Mental Health Day(s)
 - a. Attendance (Page 25)
 - g. Mental and behavioral health of the student (max of 5 days per school year)

3. Mental Health Resource(s) Section
 - a list of mental health resources and services can be found at www.mchs.net under the Students & Parents tab

Appendix A - Emergency Day Schedule

In the event that students cannot safely be in our buildings (i.e. snow day), the following e-learning schedule will be followed. We will still follow the established A-day/B-day calendar. Both campuses, Central and South, will follow this schedule.

Schedule		
Block 1	8:00am - 8:30am	Synchronous (Teacher Discretion)* <i>Log in to Google Classroom and Google Meet (if provided)</i>
	8:30am - 9:30am	Asynchronous <i>Possible activities: Continue work provided by the teacher, engage in group work, engage in individual work, ask for help/feedback, complete online assessments, meet with counselors, deans, or social workers.</i>
Block 2	9:30am - 10:00am	Synchronous (Teacher Discretion)* <i>Log in to Google Classroom and Google Meet (if provided)</i>
	10:00am - 11:00am	Asynchronous <i>Possible activities: Continue work provided by the teacher, engage in group work, engage in individual work, ask for help/feedback, complete online assessments, meet with counselors, deans, or social workers.</i>
Block 3	11:00am - 11:30am	Synchronous (Teacher Discretion)* <i>Log in to Google Classroom and Google Meet (if provided)</i>
	11:30am - 12:30pm	Asynchronous <i>Possible activities: Continue work provided by the teacher, engage in group work, engage in individual work, ask for help/feedback, complete online assessments, meet with counselors, deans, or social workers.</i>
Lunch 12:30pm - 1:00pm		
Block 4	1:00pm - 1:30pm	Synchronous (Teacher Discretion)* <i>Log in to Google Classroom and Google Meet (if provided)</i>
	1:30pm - 2:30pm	Asynchronous <i>Possible activities: Continue work provided by the teacher, engage in group work, engage in individual work, ask for help/feedback, complete online assessments, meet with counselors, deans, or social workers.</i>
Independent work time 2:30pm - 3:00pm		

*For example, if an emergency day falls on a day that students would be working on a project, reading chapters in a novel, practicing problems from a previous lesson, etc. then the teacher may post the assignment and directions on the Google Classroom for the students to use this time to continue working independently. However, if the teacher's lesson plans include new material, class discussion topics, small group work activities, etc., then the teacher may provide a Google Meet link for all students to join.

Staff member responsibilities:

- Post assignments on Google Classroom by 8:00am.
- Post Google Meet link, if needed.
- Planning/Professional Responsibilities.
- Enter student attendance. This can be accomplished through your Google Meet, Google Form, assignment completion, etc.

Student responsibilities:

- Cameras on, if applicable.
- Engage in the assignments that are posted.
- Reach out to your teacher if you have any questions.

New Procedures/Language: Discipline

1. Revist Drug Proposal from Fall of 2021

Drug/Alcohol Offenses & Consequences

THC Possession, Use, and Under the Influence	Alcohol Possession, Use, and Under the Influence
<p>1st Offense</p> <ul style="list-style-type: none"> - 10 Day Out of Building Suspension - Police Notification - Social Suspension Remainder of School Year - Drug Counseling Assessment (Outside) <ul style="list-style-type: none"> - Pre-approved District program(s) - Behavioral Agreement with District to abide by program recommendations - Placement may occur if assessment and recommendations are not followed <p>May Include</p> <ul style="list-style-type: none"> - No Pass List - Parking Privileges Revoked (If Applicable) - Possible Recommendation for Expulsion 	<p>1st Offense</p> <ul style="list-style-type: none"> - 10 Day Out of Building Suspension - Police Notification - Social Suspension Remainder of School Year - Alcohol Counseling Assessment (Outside) <ul style="list-style-type: none"> - Pre-approved District program(s) - Behavioral Agreement with District to abide by program recommendations - Placement may occur if assessment and recommendations are not followed <p>May Include</p> <ul style="list-style-type: none"> - No Pass List - Parking Privileges Revoked (If Applicable) - Possible Recommendation for Expulsion
<p>2nd Offense</p> <ul style="list-style-type: none"> - 10 Day Out of Building Suspension w/ possible recommendation for expulsion - Police Notification - 2 Semester Placement 	<p>2nd Offense</p> <ul style="list-style-type: none"> - 10 Day Out of Building Suspension w/ possible recommendation for expulsion - Police Notification - 2 Semester Placement

All Other Drug Offenses

THC Distribution	All Non-THC Drug Possession/Use/Sale
<p>1st Offense</p> <ul style="list-style-type: none"> - 10 Day Out of Building Suspension w/ possible recommendation for expulsion - Police Notification - Minimum 2 Semester Placement - Drug Counseling Assessment (Outside) which may reduce outside placement 	<p>1st Offense</p> <ul style="list-style-type: none"> - 10 Day Out of Building Suspension w/ possible recommendation for expulsion - Police Notification - Minimum 2 Semester Placement - Drug Counseling Assessment (Outside) which may reduce outside placement
<p>2nd Offense</p> <ul style="list-style-type: none"> - 10 Day Out of Building Suspension w/possible recommendation for Expulsion - Police Notification 	<p>2nd Offense</p> <ul style="list-style-type: none"> - 10 Day Out of Building Suspension w/possible recommendation for Expulsion - Police Notification

Current Handbook

STUDENT-ATHLETE DISCIPLINARY ACTION

A student accused of a violation will be informed of the charge and given an opportunity to respond. Any student found to be in violation of the Student-Athlete Disciplinary Code is subject to disciplinary action. Penalties for violations of the above disciplinary code may be carried over from one sport season to another or from one year to the next. If a violation occurs out of season, the penalty will begin at the start of the athlete's next season. Student-athletes must successfully complete the current season for the penalty to count. Failure to complete the season will result in the penalty being served in the athlete's next season. Student-athletes are expected to attend all practices and games while serving a suspension that will end before the conclusion of the season. Student-athletes serving a Level year suspension will not be allowed to participate with any athletic team until the season their suspension ends. If a student-athlete's suspension ends during an upcoming season, the student-athlete will be allowed to try out in that season.

PROBATION

Probation is a warning to a student-athlete that any further violations of the student-athlete disciplinary code will result in some type of an athletic suspension. Probation lasts for one calendar year from the date of occurrence. The following actions will cause a student-athlete to be placed on probation, in addition to any other discipline that may be imposed:

- a. Falsification of signatures on any athletic form.
- b. Being in attendance where there is illegal use or possession of drugs or alcohol, if the student can supply documented evidence that he or she was not using drugs or alcohol.
- c. Other misconduct, at the discretion of the administration.

SUSPENSION

Level One

A Level One violation will result in loss of 20% of the regular season dates. The following are Level One violations:

- a. Severe violations of the MCHS student handbook disciplinary code.
- b. Repeated or serious acts of unsportsmanlike conduct.
- c. Theft or vandalism of personal or school property.
- d. Any use of tobacco products.
- e. When an athlete has received probation for a second time.

Level Two

Current Handbook -

The following are Level Two violations:

- a. An athlete is assigned the Level Two consequence when they have violated a Level One incident for the second time.
- b. A Level Two violation will result in a one calendar year suspension from the date of occurrence.
- c. Use and/or possession of drugs or alcohol on or off school grounds. This includes school-sponsored transportation to and from away events.

If the violation is related to alcohol or drugs and the athlete enrolls and successfully completes an alcohol or substance abuse education program approved by the Athletic Director, the suspension can be reduced to 50% of the regular season. If the student fails to complete, attend, or choose to not take the education option, they will then be suspended for one calendar year. If a Level Two consequence is given a second time to a student/athlete, there will be no reduction in the calendar year suspension.

Proposed Handbook Changes

The following are Level Two violations:

- Use and/or possession of drugs or alcohol on or off school grounds. This includes school-sponsored transportation to and from away events.
- An athlete is assigned the Level Two consequence when they have violated a Level One incident for the second time.

First Level 2 Offense

A student, who violates the Code of Conduct for a first offense, will be issued a suspension totaling 50% of the entire competition season of an athletic or performance-based activity. The suspension must be served during the dates assigned by the athletic director or administration. Depending on the time left in the season, the suspension may transfer to the next season, activity, or school year.

First Offense Only Reduction Option

This option allows a student who violated the Code, for the first time, to reduce their suspension from 50% of the entire performance season, to 25%. A student wishing to utilize this reduction option will need to participate in a District 111-approved assessment, counseling, or community service option, appropriate to the offense. Note: District 111 is not responsible for any cost incurred in an assessment or counseling option. This option is not available when there is a pending police report or when an arrest has been made.

Second Level 2 Offense

A student being issued a Code of Conduct violation for a second offense will be issued a suspension totaling 50% of the entire competition season of an athletic or performance-based activity. The suspension must be served during the dates assigned by the Athletic Director or Administration, and depending on the time left in the season the suspension may transfer to the next season, activity, or school year. Note: There is no reduction option available for the second or subsequent offenses.

Third Level 2 Offense

A student being issued a Code of Conduct violation for a third offense will be permanently removed from all Minooka Community High School athletics, extra-curricular activities, contests, practices, or performance events for the remainder of the student's high school career.

CONDITIONS OF THE REDUCTION OPTION

When a student chooses to participate in the first offense reduction option, he or she is required to follow the recommendations resulting from the evaluation or treating professional. Documentation of such a program or evaluation must be provided to the Athletic Director or Administration. Once treatment is completed, documentation verifying the completion should also be presented to the Athletic Director or Administration. Note: District 111 is not responsible for any cost incurred in an assessment or counseling option. This option is not available when there is a pending police report or an arrest has been made.

Rational-

The proposed changes would involve the Level 2 Section of the Athletic/Activity Handbook.

Current Handbook-

1st Offense-50% of the season contest suspension (with an approved assessment),

2nd Offense-a calendar year suspension

3rd Offense-suspended for their remaining high school career

Proposed Handbook change-

1st Offense-25% of season contest suspension (with an approved assessment),

2nd Offense-50% of season contest suspension,

3rd Offense-suspended for their remaining high school career.

Raven
systems

Bid Form

SEAL COATING

South Campus Only

Measured Square Footage: 387,100

Price for south campus: \$34,000.00

CRACK FILLING

Price per pound: \$1.00

Estimated total pounds: 7,500 #

Estimated pounds for Central Campus 3,000 #

Estimated pounds for South Campus 4,500 #

STRIPING:

South Campus Only

Per lineal foot: \$0.25

Estimated total Lineal Feet: 30,000 L.F.

Estimated lineal feet for South Campus 30,000 L.F.

ASPHALT PATCHING

Price per ton: \$176.00

Estimated total tons: 700

Estimated total Square Feet of recommended patching: 27,450 SF

Estimated square feet for Central Campus 450, Estimated tons 15

Estimated square feet for South Campus 27,000, Estimated tons 685

CONCRETE WORK

Price per submitted drawing of Recommended Work: \$38,000.00
(contractor to submit drawing or proposed work)

Bid Form

Denler, Inc.

20502 S Cherry Hill Rd.

Joliet, IL 60433

708 479 5005

ddenler@denlerinc.com

Ar, M

SEAL COATING

South Campus Only

Measured Square Footage: 396,713

Price for south campus: \$ 39,275.-

CRACK FILLING

Price per pound: 2.10

Estimated total pounds: 10,000

Estimated pounds for Central Campus 5,000

Estimated pounds for South Campus 5,000

STRIPING:

South Campus Only

Per lineal foot: .34

Estimated total Lineal Feet: 27,680

Estimated lineal feet for South Campus 27,680

ASPHALT PATCHING

Price per ton: 209.15

Estimated total tons: 616

Estimated total Square Feet of recommended patching: 24,948

Estimated square feet for Central Campus 360, Estimated tons 10

Estimated square feet for South Campus 24,588, Estimated tons 606

CONCRETE WORK

Price per submitted drawing of Recommended Work: \$ 27,068
(contractor to submit drawing or proposed work)



H2I Group
157 Eisenhower Lane North
Lombard, IL 60148

Quote: 91762

TO: Minooka South HS
Attn: Matt Williams

Date: 3/30/2022
Project: New Backstops
Location: Minooka, IL
Architect:
Addendum:

Bid Date:

We propose to furnish the following as manufactured by Porter Athletic using standard design, materials, construction sizes and colors.

Qty. (3) Porter #312 Stationary Wall Mounted Backstop 1'-2" Face of Bank (Front of Rim To Wall Approx. 38")

- #208 Glass Backboard
- #326 Bolt On Bottom Edge Padding
- Power Flex Goal
- Manual Height Adjuster

Material, Freight and Installation.....\$17,880.00

Add For Power Touch Height Adjuster (All Electric By Others).....\$1,500.00

ADD For Qty. (2) Porter #872 INDOOR FLOOR SLEEVE; 3-1/2" POST; 5" CHROME COVER

- Installed

Material, Freight and Installation.....\$1,650.00

ADD For Crew To Paint Qty. (1) ONE Volleyball Court on Existing Surface
(Includes 3 Free Throw Ticks For Free)

Material, Freight and Installation.....\$5,600.00

Excludes:

1. State Sales & Use Taxes. Purchaser by acceptance of this quotation agrees to furnish Tax Exemption Certificates when requested on non-taxable materials.
2. Charges for vertical transportation, Mechanical utilities and connections, Electrical utilities and connections, Bonds, Removal of existing equipment, Traps, Ducts, Fume hood fan/blowers, Rubber/vinyl base, Liquidated damages. Note: Clean-up to be limited to removing all debris, dirt and rubbish accumulated as a result of our installation to a dumpster provided by others, leaving the premises broom clean and orderly.
3. 50% Down payment is required for new customers and or private facilities
4. Payments Made by Credit Cards Are Subject To A 3% Processing Fee
5. Purchase Order Number Required
6. We reserve our right to a schedule extension; change orders for additional costs (including but not limited to material escalation; labor rate increases; acceleration costs; shipping costs; storage costs; administration

Solutions for Industry, Education, and Healthcare Since 1924



100% Employee Owned and Driven



H2I Group
157 Eisenhower Lane North
Lombard, IL 60148

overhead; etc.) related to any occurrence of an event which is outside of our reasonable control and which prevents us from performing our obligations (Examples but not limited to: acts of God; strikes or other labor disturbances; delays in transportation; war; acts of terrorism; epidemics (such as COVID-19); etc.

SEE & SIGN PAGE 2 for Terms & Conditions

This proposal is based upon usage of the AGC/ASA/ASC "Standard Form Construction Subcontract", 1996 Edition or a subcontract form otherwise acceptable to Haldeman-Homme, Inc.

TERMS: Net 30 Days

ACCEPTED: Company _____ RESPECTFULLY,
Name _____ **HALDEMAN-HOMME, INC.**
Date _____ By *Gavin Wilk*

PURCHASE ORDER # _____ Gavin Wilk

Note: This quotation is offered for acceptance within 30 days and is subject to revision beyond that time.

H2I Group Inc. Terms and Conditions

General

These terms and conditions are a component part of the attached proposal and constitute the entire agreement between H2I Group Inc. (hereinafter H2I). By signing the proposal, Customer acknowledges that they understand and accept the proposal and the following terms and conditions. All work shall be done in accordance with the attached proposal unless otherwise provided for in writing and signed by H2I. Applicable sales, excise and use taxes are not included unless otherwise stated in the proposal. Tax exempt entities hereby agree to furnish tax exemption certificates when requested on non-taxable materials. Material Only Contracts: Responsibility for the unloading, handling, storage and installation of material transfers to the Customer upon shipment from the factory. Customer is responsible for receiving, unloading and inspecting materials and filing freight claim for any shortage or damage of materials. Delivery and freight charges are not included unless otherwise stated in the proposal.

Site Conditions

A smooth, level and clean sub-floor shall be provided or as required by H2I. Maintain environment at proper temperature (55-80 degrees F.) and humidity (35-50%) before, during and 30 days following installation. Delays due to circumstances beyond the control of H2I shall entitle H2I to an equitable adjustment of time and contract price.

Acceptance

This proposal may be accepted within 30 days subject to credit approval. H2I reserves the right to revoke this offer prior to acceptance by customer. Customer agrees that, by signing, grant authority to credit bureaus to release credit history information for the purpose of establishing credit with H2I and its subsidiaries. H2I and its subsidiaries may, if payment for work performed by H2I will pass thru from a third party require a credit application, joint check agreement with the property owner/end user if the property owner/end user is a separate entity from the Customer, a copy of the Customer's payment bond, and/or a personal guarantee, as a condition of credit approval. Customer agrees that payments received from a third party for services performed by H2I shall be held in trust and first paid to H2I for material and labor costs paid by H2I.

Installation

This proposal assumes unloading and elevator use shall be conducted during normal business hours. This proposal is based on completing the work during normal business hours. Overtime, evening and weekend work is available at additional charge. Customer agrees to provide H2I with sufficient and timely unloading facilities, dock and elevator access as needed at no additional cost to H2I. Customer shall provide temporary, secure storage for materials prior to installation. Customer shall provide adequate electrical power, lighting, water and restroom facilities during installation. Customer shall provide area that is free and clear and prepared for installation.

Engineering

All engineering, proposal drawings, specifications shall represent H2I's investment in engineering skill and development and remain the property of H2I. Such are submitted with the understanding that the information will not be disclosed or used in any way detrimental to H2I's interests.

Changes

Any requests for changes to the scope of work shall be made in writing with signed acceptance by authorized personnel from H2I and Customer.

Liability



100% Employee Owned and Driven

Solutions for Industry, Education, and Healthcare Since 1924



H2I Group
157 Eisenhower Lane North
Lombard, IL 60148

H2I shall not be liable for damages in any form or any other claim arising out of strikes, floods, fire, accidents, or any other causes beyond our control. H2I shall not be liable for liquidated, consequential or any other damages or penalties of any kind for delays in completion of work. H2I indemnity obligations to the Customer and owner are limited to the liability created by the gross negligence of Haldeman Homme Holdings, its employees or subcontractors. In the event the terms of this agreement conflicts with the Customer's proposal or purchase order the parties acknowledge and agree the terms of this agreement shall control.

Payment

Payment in full will be due and payable thirty (30) days from invoice date. Customer agrees to pay progress-billing invoices during the course of the project reflecting partial shipment of material and/or partial completion of labor work performed. Where materials are stored or staged temporarily at the job site or in offsite or bonded warehouse, customer shall pay for materials and reasonable storage charges. The failure of the Customer to make payments within contract terms shall entitle H2I, in addition to all other rights, to suspend all work and shipments and shall further entitle H2I to an extension of time of performance of the work. No payments shall be withheld from or penalties assessed against H2I due to causes for which H2I is not responsible.

Customer agrees that, if the billed amount is not paid within terms, a service charge will be charged on the overdue balance at a percentage rate of 1.5% (18% ANNUAL PERCENTAGE RATE) for all accounts. If the customer fails to pay the entire unpaid balance on the account when due H2I may without further notice or demand, exercise all rights and remedies available by law for the collection of the balance due on the account. H2I reserves the option to exercise its lien rights at all times in accordance with applicable law to secure collection of amounts due. Applicant will be liable for all expenses of collection with or without suit, including all court costs and reasonable attorney's fees to the extent under applicable state law. Venue shall be the State District Court of Minnesota.

Disputes

Customer and H2I hereby agree that disputes between the parties which cannot be settled amicably, shall be settled through the State District Court of Minnesota.

Cancellation

An officer of H2I must approve cancellation requests in writing. In order to compensate H2I for its investment in engineering, time, processing and administrative work, approved cancellations shall be subject to cancellation charge of 25% of the contract amount plus the cost of materials produced or in production, labor or other services performed, freight, taxes and any other out of pocket expenses incurred by H2I.

Warranty

THE MANUFACTURER EXPRESS WARRANTY IS PROVIDED IN LIEU OF ALL OTHER WARRANTIES, EXPRESS OR IMPLIED. THE WARRANTIES OF MERCHANTABILITY AND FITNESS FOR A PARTICULAR PURPOSE ARE HEREBY DISCLAIMED BY H2I.

Insurance

H2I maintains insurance and will provide certificates of insurance if requested on coverage and limits as provided by its insurance policy. No other insurance coverage is provided including waiver of subrogation or additional named insureds.

Codes

Customer, architect and/or contractor shall be responsible for all local, state and federal agency code compliance, permits, fees, design, engineering and testing. H2I does not provide professional liability or pollution insurance for any of these services. Costs for any and all such services are not included in this proposal.

Signature: _____ Name: _____ Date: _____
(Please Print)



100% Employee Owned and Driven

Solutions for Industry, Education, and Healthcare Since 1924

Phone: (612) 331-8816
Fax: (612) 331-4884
Toll Free: (888) 239-8747
Email: info@h2igroup.com
Website: www.h2igroup.com

Serving all 50 states, Offices located:

Atlanta|Austin|Baltimore|Chicago|Cedar Falls|Columbia|Dallas|Denver|Des Moines|Grand Forks|Kansas City|Houston|Madison|Minneapolis|Omaha|Salt Lake City|Tampa

236154 - POWR-FLEX II GOAL

WITH TUBE TIE NET ATTACHMENT, MOUNTING HARDWARE, AND NET
QUALIFIES AS 22302 POWR-FLEX GOAL EQUIVALENT

Porter
 WWW.PORTERATHLETIC.COM/FACILITY

BASKETBALL SPECIFICATION SHEET

B-236154

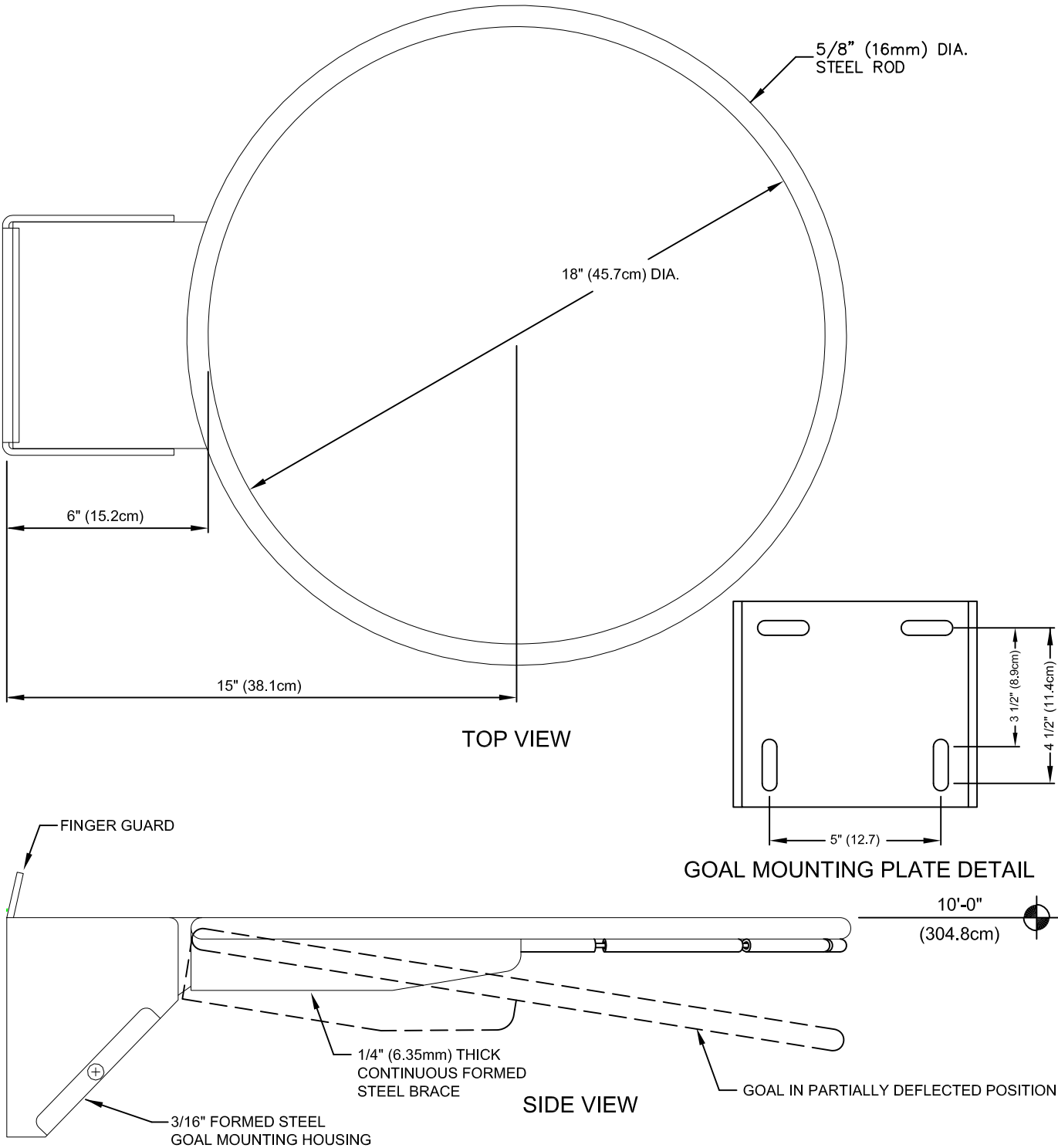

- 236154 POWR-FLEX II GOAL WITH HARDWARE AND NET
 SEE B-200 FOR COMPATABLE BACKBOARDS

Porter[®]

888-277-7778 PORTER@PORTERATHLETIC.COM
 © COPYRIGHT 2012 PORTER ATHLETIC - ALL RIGHTS RESERVED

15 PROJECT NUMBER

PROJECT NAME

1/29/2013

236154 - POWR-FLEX II GOAL

WITH TUBE TIE NET ATTACHMENT, MOUNTING HARDWARE, AND NET

SPECIFICATIONS

Shock absorption feature shall be provided by means of a special, offset hinge arrangement rim and backplate mounting housing containing concealed spring mechanisms. Hinge shall be positioned to place goal return impact forces in shear (parallel) to minimize oscillation induced into the face of the backboard. Front of rim shall deflect downward up to 2-1/16" when a static load of 250 pounds is applied and instantly return to playing position when load is released.

Function of goal shall meet the NCAA specifications on moveable rims, which states "A moveable basket ring shall have rebound characteristics identical to those of a non-moveable ring." Goal shall be set at factory for proper flex and rebound requirements.

Rim shall be fabricated from 5/8" diameter cold drawn alloy steel, round formed to an 18" inside diameter ring. Inside diameter of ring shall be positioned 6" from face of backboard by a heavy formed steel, hinged type housing with a removable cover to conceal mounting bolts and spring mechanisms of goal, and also protect against finger entrapment. Goal mounting plate shall be provided with hardware and a 5" x 4" mounting hole pattern for front mounting on standard glass, wood and fiberglass type backboards and is also compatible for use with all Center-Strut direct mount type support frames.

Rim shall be rigidly braced by means of a formed steel brace welded in position on the underside of the rim for maximum support. Rim shall be provided with a unique "tube-tie" net attachment system to eliminate the conventional wire-formed type net locks for additional player safety.

Goal shall be furnished in a durable, official orange powder-coat finish.

Goal shall be furnished complete with plated mounting hardware and an anti-whip net.

Goal shall meet equal functional specifications than 236154 Ultra-Flex goal.

For details on compatible backboards see B-200.

WARRANTY

- 236154 goal furnished with a 3-year limited warranty.

OPTIONAL ITEMS (SEE SPECIFICATION SHEETS FOR DETAIL)

- Fair-Court Basketball Rim Testing System (ERT2003NCAA)
- RING001 - Training aid shooters ring
- RING002 - Training aid rebound ring

POWR-TOUCH OPERATION

CENTER-STRUT® HEIGHT ADJUSTMENT SYSTEM FOR WALL-MOUNTED BACKSTOPS - ELECTRIC OPERATION WITH POWR-TOUCH®

Porter
WWW.PORTERATHLETIC.COM/FACILITY

OPERATION SPECIFICATION SHEET

W-200-4

NOTE - FOR USE ONLY WITH PORTER No. 00267-698 FAN FIBERGLASS AND PORTER No. 00234-000 or 00234-300 FAN ALUMINUM BACKBOARDS, AND ALL PORTER RECTANGULAR BACKBOARDS.

POWR-TOUCH® OPERATION

WIRING FROM JUNCTION BOX TO POWR-TOUCH® RELAY PANEL BY ELECTRICAL CONTRACTOR - AS REQUIRED TO MEET ALL LOCAL ELECTRICAL CODES

SEE PAGE No. W-200-4-P FOR FIELD WIRING DETAILS AND REQUIREMENTS

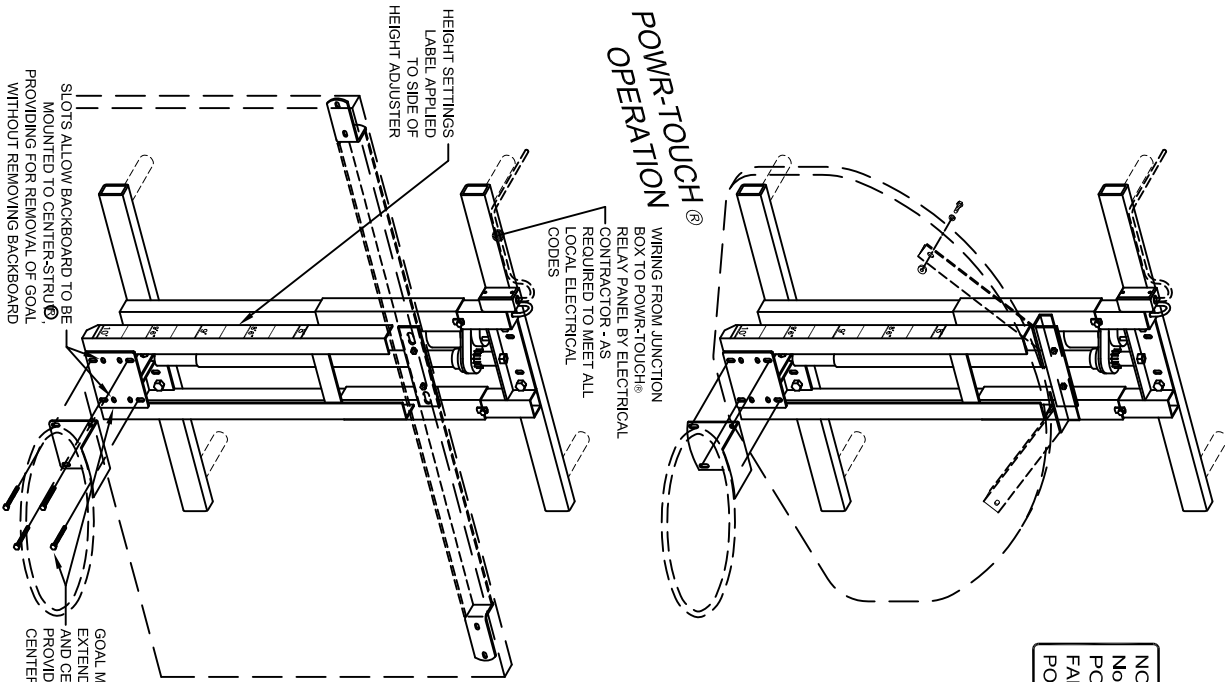

SLOTS ALLOW BACKBOARD TO BE MOUNTED TO CENTER-STRUT®, PROVIDING FOR REMOVAL OF GOAL WITHOUT REMOVING BACKBOARD

GOAL MOUNTING HARDWARE EXTENDS THRU BACKBOARD AND CENTER CHANNEL TO PROVIDE DIRECT-MOUNT CENTER-STRUT® FEATURE

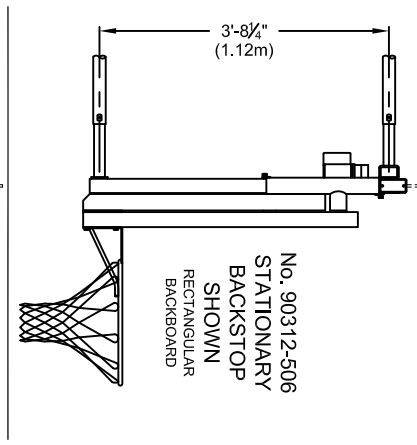
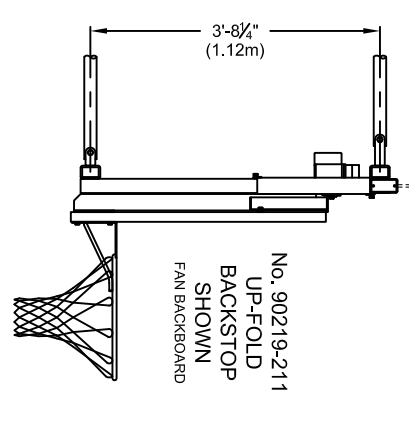
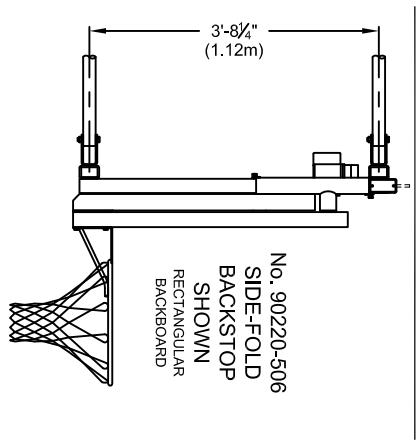

Porter®

17 PROJECT NUMBER

PROJECT NAME

POWR-TOUCH OPERATION

CENTER-STRUT® HEIGHT ADJUSTMENT SYSTEM FOR WALL-MOUNTED BACKSTOPS - ELECTRIC OPERATION WITH POWR-TOUCH®

SPECIFICATIONS

PORTER No. 90 -211 and 90 -506

CENTER-STRUT® HEIGHT ADJUSTMENT SYSTEM WITH ELECTRIC POWR-TOUCH® OPERATION FOR USE ON WALL-MOUNTED BACKSTOPS

Height adjustment unit shall be designed for use with No. 312, 219 and 220 series wall-mounted basketball backstop support systems to provide an adjustable, direct mount (Center-Strut®) goal attachment system to eliminate any strain on the backboard should a player hang on the front mounted goal (conforms to the latest NCAA recommendation). Height adjustment units without the prescribed direct mount goal feature will not be approved as equal. Height adjustment feature will allow goal height settings from 8'-0" to the official 10'-0" for use by all age groups. Unit shall be designed for use only with Porter No. 00267-698 fan fiberglass or No. 00234-000 or 00234-300 fan aluminum backboards, or with any official size (4' x 6', or 3'-6" x 6') Porter rectangular backboard.

Center unitized support frame shall be fabricated by dual, 2-3/16" square heavy wall zinc plated guide tubes located on 11-3/16" centers. Ends of guide tubes shall be welded to heavy, formed mounting brackets. Outer dual slide tubes shall support heavy structural steel angle sections which extend downward to accept a direct mount (Center-Strut®) goal mounting system. Slide tube assembly shall be provided with a heavy steel section to attach a special upper backboard support assembly to secure the unit to the upper two corners of the backboard.

Height adjustment unit shall incorporate a compact 115-volt, gear motor type linear actuator with 600 pound thrust capacity to raise and lower the goal height electrically. Motor shall draw 1.4 amps under full load. Integral limit switches shall provide automatic shut off at 8' and 10" goal heights. The motor shall be controlled by Porter No. 2500 or 2550 Powr-Touch® Gymnasium Control Systems. Specify separately Powr-Touch® Key Pad and Powr-Touch® Control Panel – quantities as required. See Page No. E-2500 or E-2550 for details and specifications. Wiring from junction box on height adjuster frame to relay panel on Powr-Touch® System shall be provided by the electrical contractor to meet all local code requirements.

Wiring of all electrical components shall be in accordance with local area codes, and in accordance with manufacturer's instructions. All conduit, wiring, junction boxes and components not specified herein shall be furnished and installed by the electrical contractor.

A height setting scale shall be located on the side of the unit to visually determine height settings from 8'-0" to 10'-0" in 3" increments.

Height adjustment frame shall be finished with one coat of flat black enamel. (If painting of special colors is required, specify final painting by painting contractor.)

LIFETIME WARRANTY (ADD TO SPECIFICATIONS AS REQUIRED)

Limited Lifetime warranty on Porter backboards when used in conjunction with Porter Center-Strut® height adjustment unit installed on a Porter wall-mounted backstop.

POWR-TOUCH® FIELD WIRING

CENTER-STRUT® HEIGHT ADJUSTMENT SYSTEM ELECTRIC OPERATION With POWR-TOUCH® KEY PAD CONTROL FIELD WIRING DETAILS and REQUIREMENTS

NOTE - All wiring between the height adjuster and the relay panel is to be done by an electrical contractor per the diagram below, to meet all local code requirements.

IMPORTANT NOTE - PERFORMANCE OF MOTOR IS BASED ON HAVING 115 VOLTS AT MOTOR TERMINALS. VOLTAGES LESS THAN 115 VOLTS WILL AFFECT HOISTING CAPACITY AND RESULT IN DAMAGE TO MOTOR THUS VOIDING WARRANTY.

CAUTION
 POWR-TOUCH® KEY PAD MUST BE MOUNTED ON THE WALL IN A LOCATION SO THAT THE EQUIPMENT IT IS CONTROLLING IS IN FULL VIEW OF THE OPERATOR.

NOTE
 ELECTRICAL CONTRACTOR TO PROVIDE FIELD WIRING AS REQUIRED TO MEET ALL LOCAL ELECTRICAL CODES.

TO RELAY SET IN RELAY PANEL OF POWR-TOUCH® CONTROL SYSTEM. REFER TO POWR-TOUCH® INSTALLATION MANUAL FOR COMPLETE WIRING DIAGRAM.

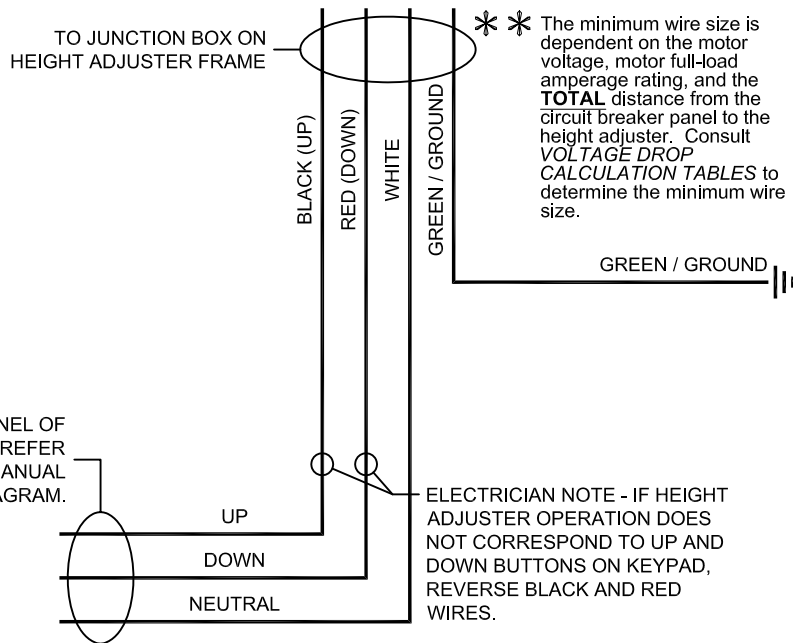

00312-012 - WALL-MOUNTED BACKSTOP

WALL MOUNTED BACKSTOP WITH CENTER-STRUT® HEIGHT ADJUSTER - RECT. BACKBOARD - FLUSH MOUNT (1'-2")

Porter
WWW.PORTERATHLETIC.COM/FACILITY

WALL MOUNT SPECIFICATION SHEET

W-312-RFH

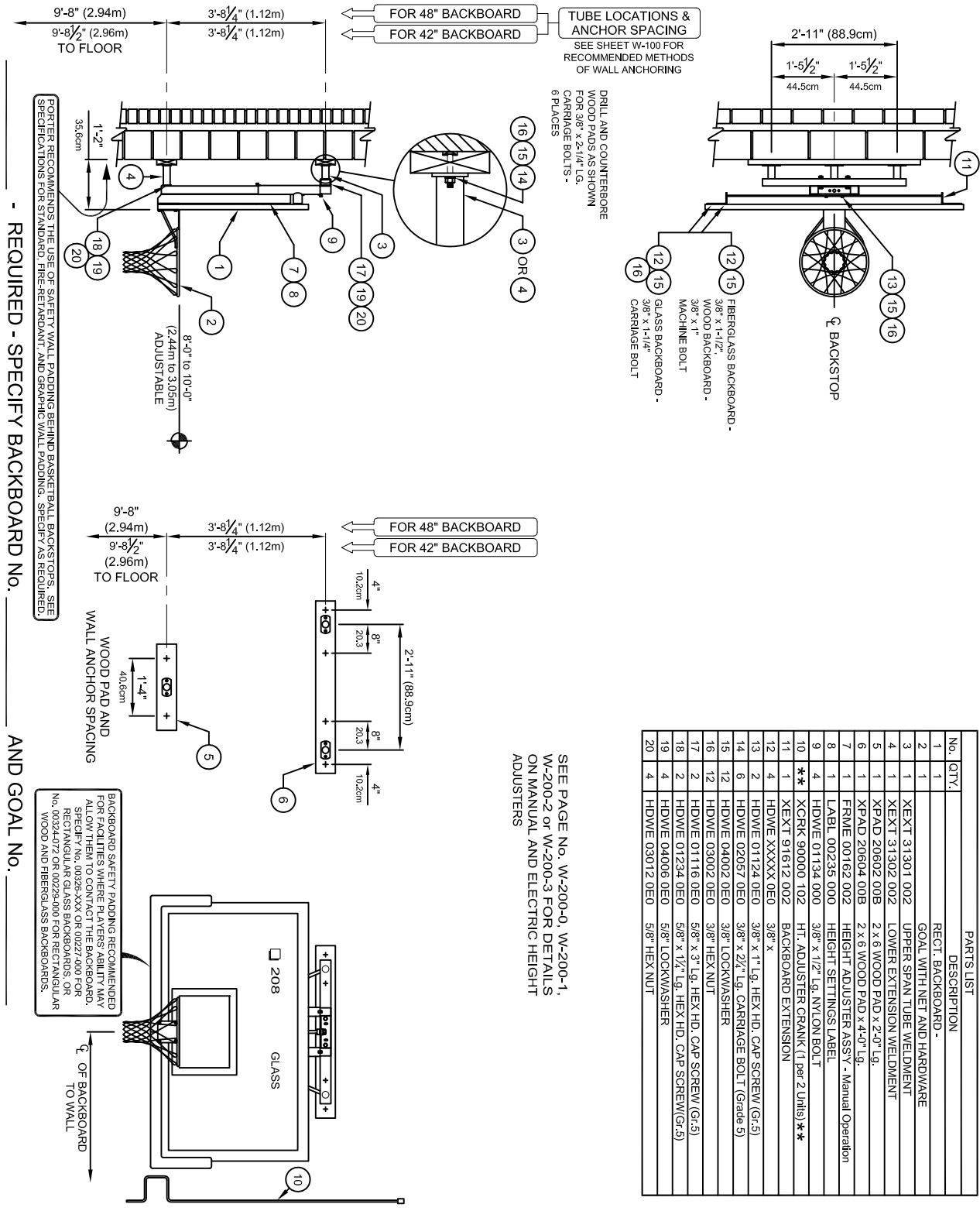

Porter[®]

PROJECT NUMBER

PROJECT NAME

00312-012 - WALL-MOUNTED BACKSTOP

WALL MOUNTED BACKSTOP WITH CENTER-STRUT® HEIGHT ADJUSTER
- RECT. BACKBOARD - FLUSH MOUNT (1'-2")

SPECIFICATIONS

PORTER No. 00312-012 WALL BRACED BACKSTOP WITH CENTER-STRUT® HEIGHT ADJUSTMENT UNIT FOR RECTANGULAR BACKBOARD

Backstop shall be wall-braced type with face of backboard extended 1'-2" from supporting wall. Extension frames shall be fabricated of three (3) 1-7/8" O.D. tubes. Upper extensions shall terminate in a heavy wall rectangular tube assembly on standard 2'-11" centers for attachment to height adjustment unit. Lower extension shall terminate in a heavy steel flange for attachment to height adjustment unit. Extension frame assemblies shall terminate in heavy steel flanges for attachment to wall pads.

Southern yellow pine wall pads shall be provided at all wall attachment points. All edges shall be chamfered and pads shall be finished with two finish coats of natural gloss lacquer.

Height adjustment unit shall be designed to provide an adjustable, direct mount Center-Strut® goal attachment system to eliminate any strain on the backboard, should a player hang on the front mounted goal. Height adjustment units without the prescribed direct mount goal feature will not be approved as equal. Height adjustment feature will allow goal height settings from 8'-0" to the official 10'-0" for use by all age groups. Unit shall be designed for use with any official size (4' x 6' or 3'-6" x 6') Porter rectangular backboard and companion front-mount type goal.

Center unitized support frame of height adjustment unit shall be fabricated by dual, 2-3/16" square heavy wall zinc plated guide tubes located on 11-3/16" centers. Ends of guide tubes shall be welded to heavy mounting brackets. Outer dual slide tubes shall support heavy structural steel angle sections which extend downward to accept a direct mount Center-Strut® goal mounting system. Slide tube assembly shall be provided with a heavy formed steel section to attach a horizontal backboard support assembly to secure the unit to the upper two corners of the rectangular backboard on standard (5'-6") mounting centers.

Height adjustment unit shall incorporate a centrally located 3/4" diameter Acme threaded rod equipped with precision, hardened steel roller thrust bearings for ease of operation from the playing floor by means of an awning crank-type mechanism. Height adjustment system shall incorporate an internal, spring-loaded height locking mechanism to automatically lock and hold unit at any desired goal height during play. Lock mechanism automatically releases when height setting changes are made with adjustment crank assembly. Adjustment crank assembly shall be provided with each pair of height adjustment units. A height setting scale shall be located on the side of the unit to visually determine height settings from 8'-0" to 10'-0" in 3" increments.

Limited Lifetime warranty on all Porter rectangular backboards when used in conjunction with Porter Center-Strut® height adjustment unit installed on a Porter No. 312 Wall-Braced Backstop.

All metal parts shall be painted one (1) coat of flat black enamel. (If special painting of colors is required, specify final painting by painting contractor.)

Specify backboard and goal as required.



2112 W. Galena Blvd., Aurora, IL 60506
 (630) 897-2322; (630) 897-2458 (fax)
kirhofers@kirhoferssports.com

QUOTATION

TO: Minooka High School Basketball

DATE:
12.3.21

F.O.B.

TERMS

EST. SHIP DATE

QUANTITY

DESCRIPTION

PRICE

AMOUNT

3

each

Porter #312 Stationary Wall Mounted Backstop Face of Bank
 #208 Glass Backboard
 #326 Bolt On Bottom Edge Padding
 Power Flex Goal
 Manual Height Adjuster

\$8,500.00

\$8,500.00

Pricing Includes Material and Freight

Add For Power Touch Height Adjuster

\$1,500.00

\$1,500.00

TOTAL:

\$8,500.00

ABOVE PRICES GOOD FOR 30 DAYS.

OFFICIAL SIGNATURE

Sean Lindo

Monthly Financial Report - March, 2022

The revenues for the month of March in all funds were \$1,605,430.54 which is 2.66% of the annual budgeted revenue. Total revenue year-to-date was \$44,108,878.07, which is 72.99% of the annual budget revenue. Annual budgeted revenues for the year is \$60,428,034.30.

The expenditures for the month of March in all funds were \$3,617,628.63, which is 5.82% of the annual budgeted expenses. Total expenses year-to-date was \$40,767,187.69, which is 65.60% of the annual budget expense. Annual budgeted expense for the year is \$62,147,469.11.

Enrollment (March 31st)	2,863	South Campus	300,000 sq. ft. / 67 acres
Administrators	16	Central Campus	250,000 sq. ft. / 78 acres
Teachers Full-Time	150	Teachers Part-Time	3
Teachers LOA	3	Support Staff	140

Table 1: Year-to-Date Revenue Expense Summary

Year to Date Revenue Expenses vs. Budget	Revenue Budget	Year to Date Revenue	Expense Budget	Year to Date Expenses	Budget Deficit/Surplus	Current Deficit/Surplus
Education Fund *	37,809,332.67	28,580,678.81	36,048,347.77	26,078,647.08	1,760,984.90	2,502,031.73
Activity Fund	200,000.00	583,600.72	293,680.40	401,458.03	(93,680.40)	182,142.69
Operations & Maint Fund *	6,108,488.64	3,759,782.72	5,505,392.41	2,934,230.54	603,096.23	825,552.18
Debt Service Fund or Fund Group	8,854,007.76	5,966,186.65	8,500,150.00	7,296,450.00	353,857.76	(1,330,263.35)
Transportation Fund *	2,992,698.79	2,293,031.52	2,552,867.78	2,045,825.20	439,831.01	247,206.32
I.M.R.F./Soc. Sec. Fund	1,074,209.49	785,230.19	925,096.56	683,260.04	149,112.93	101,970.15
Capital Projects Fund or Fund Group	296,600.00	95,605.14	5,000,000.00	234,811.44	(4,703,400.00)	(139,206.30)
Working Cash Fund *	857,541.05	571,542.22	0.00	0.00	857,541.05	571,542.22
Tort Immunity and Judgment Fund	1,381,714.85	903,661.96	1,321,934.19	1,092,505.36	59,780.66	(188,843.40)
Fire Prevention & Safety Fund	853,441.05	569,558.14	2,000,000.00	0.00	(1,146,558.95)	569,558.14
Total All Funds	60,428,034.30	44,108,878.07	62,147,469.11	40,767,187.69	(1,719,434.81)	3,341,690.38
* Total Operating Funds	47,768,061.15	35,205,035.27	44,106,607.96	31,058,702.82	3,661,453.19	4,146,332.45

Table 2: Month Revenue, Expense & Fund Balances

Mar	* Education Fund	* Operations & Maint Fund	Debt Service Fund or Fund Group	* Transportation Fund	I.M.R.F./Soc. Sec. Fund	Capital Projects Fund or Fund Group	* Working Cash Fund	Tort Immunity and Judgment	Fire Prevention & Safety Fund	Activity Fund	Total All Funds	* Total Operating Funds
Revenue	1,282,265	91,107	449	11,786	38,491	14,287	788	9,267	123	156,866	1,605,431	1,385,947
Expense	2,766,295	410,719	450	230,085	76,753	0	0	81,646	0	51,680	3,617,629	3,407,099
Net	(1,484,030)	(319,612)	(1)	(218,299)	(38,262)	14,287	788	(72,379)	123	105,186	(2,012,198)	(2,021,153)

Table 3: Expenses by Object - Monthly

Monthly Expenses by Object	Salaries	Employee Benefits	Purchased Services	Supplies And Materials	Capital Outlay	Other	Total
July	1,511,130.51	875,395.25	230,616.49	217,522.51	122,033.50	224,911.70	3,181,609.96
August	1,604,571.99	952,327.83	674,323.85	241,481.24	110,622.61	490,521.93	4,073,849.45
September	1,641,907.88	932,071.00	-98,429.90	281,726.24	209,967.24	692,146.57	3,659,389.03
October	1,681,176.64	856,423.00	550,695.74	239,198.30	173,736.43	3,756,652.31	7,257,882.42
November	1,658,630.67	929,877.61	552,969.82	250,008.80	-38,674.50	3,600,570.81	6,953,383.21
December	1,693,167.45	988,466.99	313,026.16	148,682.11	87,976.74	1,133,190.25	4,364,509.70
January	1,646,854.73	986,847.20	684,411.35	173,728.34	47,144.52	489,947.35	4,028,933.49
February	1,697,819.68	860,258.77	380,315.43	183,794.42	102,590.18	405,223.32	3,630,001.80
March	1,658,153.90	844,795.09	363,533.62	227,588.14	114,730.88	408,827.00	3,617,628.63
April	0.00	0.00	0.00	0.00	0.00	0.00	0.00
May	0.00	0.00	0.00	0.00	0.00	0.00	0.00
June	0.00	0.00	0.00	0.00	0.00	0.00	0.00
YTD	14,793,413.45	8,226,462.74	3,651,462.56	1,963,730.10	930,127.60	11,201,991.24	40,767,187.69

Chart 1: MTD, YTD, & Budget Expenses by Object

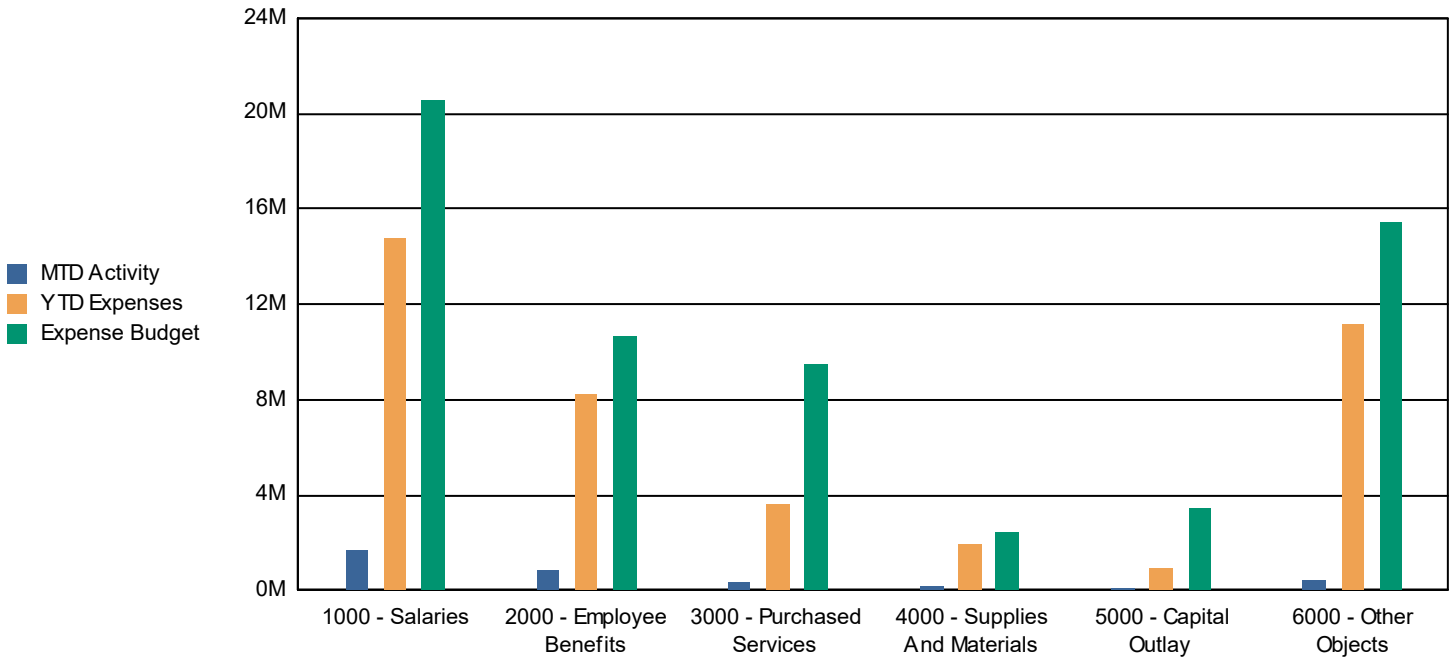
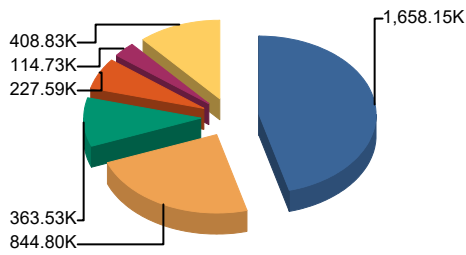

Table 4: Expenses by Object; Budget vs. Year to Date and Three Year History

Annual Revenue Summary by Object	Budget 2021-2022	Actual Year to Date 2021-2022	Percent of Budget Expended	Actual Year End		
				2020-2021	2019-2020	2018-2019
Salaries	20,582,475.79	14,793,413.45	71.87%	18,915,448.18	18,874,811.76	18,427,519.69
Employee Benefits	10,673,586.32	8,226,462.74	77.07%	9,821,573.72	6,238,178.98	6,022,474.80
Purchased Services	9,450,767.72	3,651,462.56	38.64%	5,150,233.25	8,348,470.94	6,368,029.46
Supplies And Materials	2,469,350.57	1,963,730.10	79.52%	1,948,916.62	2,269,978.81	2,236,698.08
Capital Outlay	3,489,081.55	930,127.60	26.66%	6,922,233.77	4,463,647.42	519,280.70
Other Objects	14,173,287.16	11,019,397.96	77.75%	13,496,025.63	14,609,684.68	14,908,980.94
Non-Capitalized Equipment	1,296,420.00	170,093.28	13.12%	3,996.00	0.00	77,348.00
Termination Benefits	12,500.00	12,500.00	100.00%	0.00	0.00	0.00
Total	62,147,469.11	40,767,187.69	65.60%	56,258,427.17	54,804,772.59	48,560,331.67

Chart 2: Monthly Expense



1000 - Salaries	1,658.15K	45.8%
2000 - Employee Benefits	844.80K	23.4%
3000 - Purchased Services	363.53K	10.0%
4000 - Supplies And Materials	227.59K	6.3%
5000 - Capital Outlay	114.73K	3.2%
6000 - Other Objects	408.83K	11.3%
Total:	3,617.63K	100.0%

Chart 3: Year to Date Expense

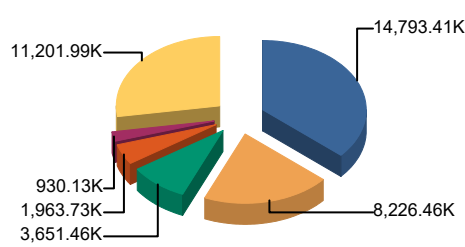

1000 - Salaries	14,793.41K	36.3%
2000 - Employee Benefits	8,226.46K	20.2%
3000 - Purchased Services	3,651.46K	9.0%
4000 - Supplies And Materials	1,963.73K	4.8%
5000 - Capital Outlay	930.13K	2.3%
6000 - Other Objects	11,201.99K	27.5%
Total:	40,767.19K	100.0%

Chart 4: Budget

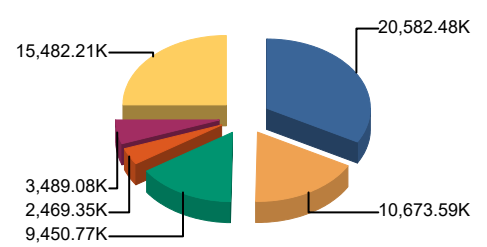

1000 - Salaries	20,582.48K	33.1%
2000 - Employee Benefits	10,673.59K	17.2%
3000 - Purchased Services	9,450.77K	15.2%
4000 - Supplies And Materials	2,469.35K	4.0%
5000 - Capital Outlay	3,489.08K	5.6%
6000 - Other Objects	15,482.21K	24.9%
Total:	62,147.47K	100.0%

Table 5: Expenses by Fund - Monthly

Monthly Expenses by Fund	Education Fund	Operations & Maint Fund	Debt Service Fund or Fund Group	Transportation Fund	I.M.R.F./Soc. Sec. Fund	Capital Projects Fund or Fund	Working Cash Fund	Tort Immunity and Judgment	Fire Prevention & Safety Fund	Total
July	2,627,650.45	216,576.01	0.00	119,943.36	68,812.51	55,701.40	0.00	53,374.60	0.00	3,181,609.96
August	3,246,211.03	265,979.29	0.00	287,716.79	73,700.33	50,367.66	0.00	98,437.95	0.00	4,073,849.45
September	2,863,883.52	300,130.95	0.00	235,731.46	76,798.88	2,841.00	0.00	74,175.58	0.00	3,659,389.03
October	2,975,440.19	317,555.77	3,433,725.00	287,979.66	77,511.89	4,271.93	0.00	139,090.84	0.00	7,257,882.42
November	2,816,052.45	362,865.18	3,212,925.00	251,499.72	75,300.59	110,431.45	0.00	90,054.08	0.00	6,953,383.21
December	3,018,433.91	330,980.09	593,900.00	227,559.91	79,594.85	11,198.00	0.00	75,935.31	0.00	4,364,509.70
January	2,848,548.66	412,709.57	55,450.00	187,992.09	74,278.42	0.00	0.00	394,167.40	0.00	4,028,933.49
February	2,916,132.17	316,714.28	0.00	217,317.02	80,509.55	0.00	0.00	85,623.68	0.00	3,630,001.80
March	2,766,294.70	410,719.40	450.00	230,085.19	76,753.02	0.00	0.00	81,645.92	0.00	3,617,628.63
April	0.00	0.00	0.00	0.00	0.00	0.00	0.00	0.00	0.00	0.00
May	0.00	0.00	0.00	0.00	0.00	0.00	0.00	0.00	0.00	0.00
June	0.00	0.00	0.00	0.00	0.00	0.00	0.00	0.00	0.00	0.00
YTD	26,078,647.08	2,934,230.54	7,296,450.00	2,045,825.20	683,260.04	234,811.44	0.00	1,092,505.36	0.00	40,767,187.69

Chart 5: MTD, YTD, & Budget Expenses by Fund

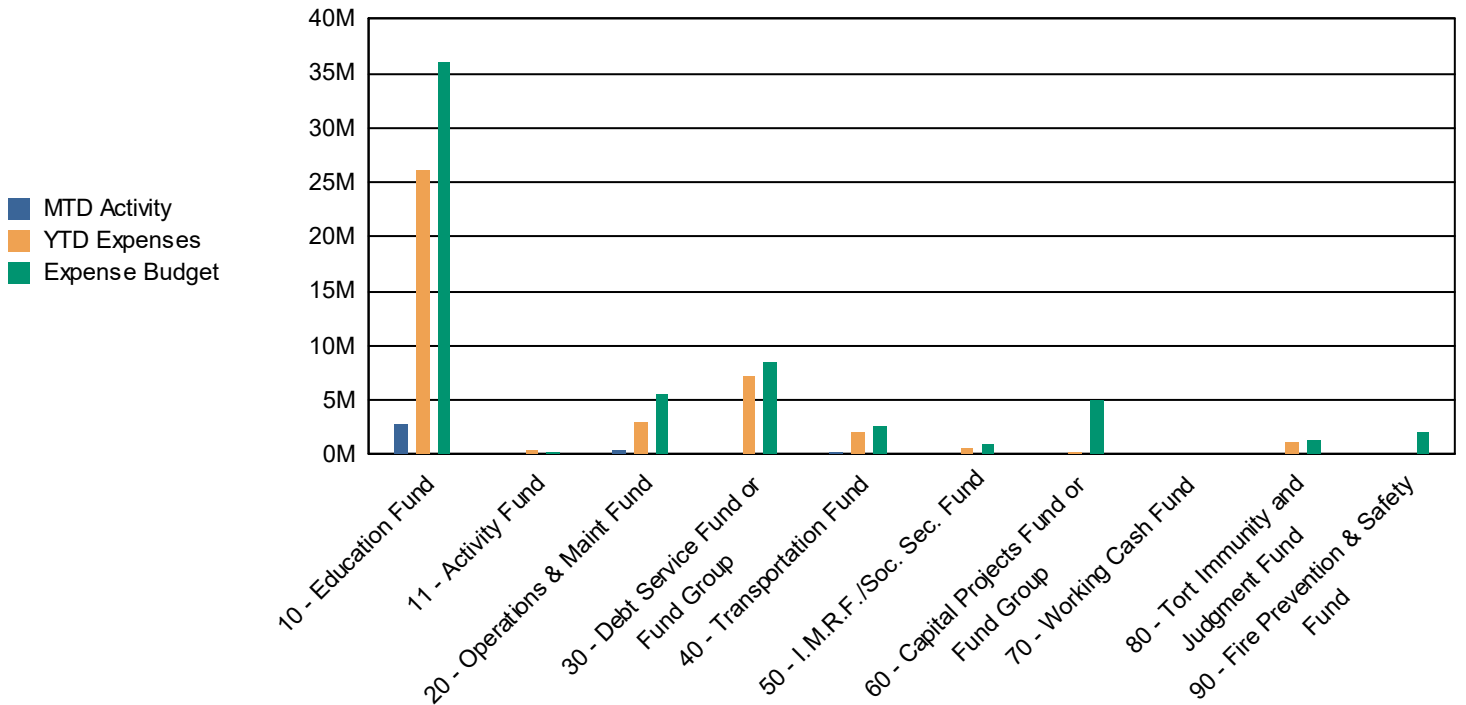

Table 6: Expenses by Fund; Budget vs. Year to Date and Three Year History

Annual Expense Summary by Fund	Budget 2021-2022	Actual Year to Date 2021-2022	Percent of Budget Expended	Actual Year End		
				2020-2021	2019-2020	2018-2019
10 - Education Fund	36,048,347.77	26,078,647.08	72.34%	32,886,815.25	29,181,337.01	27,706,590.17
11 - Activity Fund	293,680.40	401,458.03	136.70%	184,421.16	0.00	0.00
20 - Operations & Maint Fund	5,505,392.41	2,934,230.54	53.30%	3,542,666.07	3,682,838.92	3,898,623.89
30 - Debt Service Fund or Fund Group	8,500,150.00	7,296,450.00	85.84%	7,972,859.50	9,913,299.57	9,157,214.09
40 - Transportation Fund	2,552,867.78	2,045,825.20	80.14%	1,934,833.53	2,546,595.92	2,446,044.23
50 - I.M.R.F./Soc. Sec. Fund	925,096.56	683,260.04	73.86%	851,733.32	880,921.71	880,925.87
60 - Capital Projects Fund or Fund Group	5,000,000.00	234,811.44	4.70%	1,349,597.93	3,568,363.25	(8,291,119.00)
80 - Tort Immunity and Judgment Fund	1,321,934.19	1,092,505.36	82.64%	1,281,258.00	1,043,324.06	1,087,052.42
90 - Fire Prevention & Safety Fund	2,000,000.00	0.00	0.00%	6,254,242.41	3,988,092.15	0.00
Total	62,147,469.11	40,767,187.69	65.60%	56,258,427.17	54,804,772.59	48,560,331.67

Chart 6: Monthly Expense

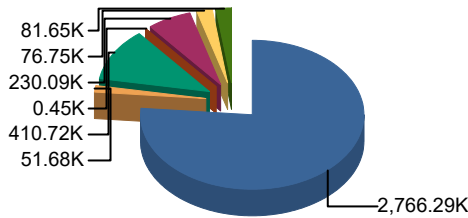

Chart 7: Year to Date Expense

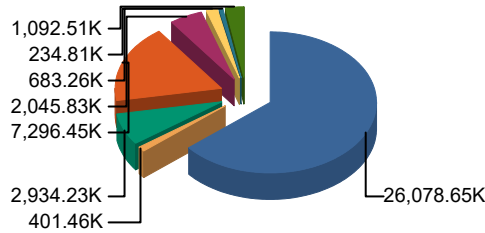
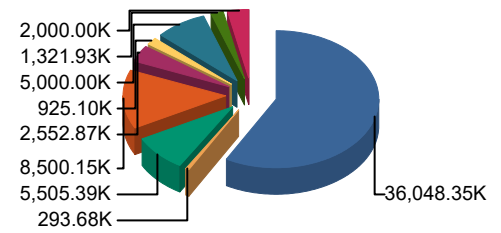

Chart 8: Budget



10 - Education Fund	2,766.29K	76.5%
11 - Activity Fund	51.68K	1.4%
20 - Operations & Maint Fund	410.72K	11.4%
30 - Debt Service Fund or Fund Group	0.45K	0.0%
40 - Transportation Fund	230.09K	6.4%
50 - I.M.R.F./Soc. Sec. Fund	76.75K	2.1%
60 - Capital Projects Fund or Fund Group	0.00K	0.0%
70 - Working Cash Fund	0.00K	0.0%
80 - Tort Immunity and Judgment Fund	81.65K	2.3%
90 - Fire Prevention & Safety Fund	0.00K	0.0%
Total:	3,617.63K	100.0%

10 - Education Fund	26,078.65K	64.0%
11 - Activity Fund	401.46K	1.0%
20 - Operations & Maint Fund	2,934.23K	7.2%
30 - Debt Service Fund or Fund Group	7,296.45K	17.9%
40 - Transportation Fund	2,045.83K	5.0%
50 - I.M.R.F./Soc. Sec. Fund	683.26K	1.7%
60 - Capital Projects Fund or Fund Group	234.81K	0.6%
70 - Working Cash Fund	0.00K	0.0%
80 - Tort Immunity and Judgment Fund	1,092.51K	2.7%
90 - Fire Prevention & Safety Fund	0.00K	0.0%
Total:	40,767.19K	100.0%

10 - Education Fund	36,048.35K	58.0%
11 - Activity Fund	293.68K	0.5%
20 - Operations & Maint Fund	5,505.39K	8.9%
30 - Debt Service Fund or Fund Group	8,500.15K	13.7%
40 - Transportation Fund	2,552.87K	4.1%
50 - I.M.R.F./Soc. Sec. Fund	925.10K	1.5%
60 - Capital Projects Fund or Fund Group	5,000.00K	8.0%
70 - Working Cash Fund	0.00K	0.0%
80 - Tort Immunity and Judgment Fund	1,321.93K	2.1%
90 - Fire Prevention & Safety Fund	2,000.00K	3.2%
Total:	62,147.47K	100.0%

Table 7: Revenues by Source - Monthly

Monthly Revenue by Source	Local Revenue Levy, CPPRT, Fees Etc.	Flow Through Funds	State Revenue GSA, Categoryicals, Grants, Etc.	Federal Revenue IDEA, Grants, Lunch Program, Etc.	Working Cash Transfer/other	Total
July	7,006,408.96	0.00	504,122.14	229,336.55	0.00	7,739,867.65
August	2,475,490.32	0.00	566,180.00	546.48	0.00	3,042,216.80
September	7,401,297.38	0.00	566,181.00	141,582.00	0.00	8,109,060.38
October	11,408,296.06	0.00	1,060,843.76	5,907.99	0.00	12,475,047.81
November	1,924,569.82	0.00	565,394.84	14,042.72	0.00	2,504,007.38
December	1,962,322.01	0.00	688,348.12	16,678.94	0.00	2,667,349.07
January	1,813,873.94	1,954,385.52	1,058,601.80	986.00	0.00	4,827,847.26
February	542,082.16	0.00	566,405.00	29,564.02	0.00	1,138,051.18
March	1,038,855.30	0.00	566,245.24	330.00	0.00	1,605,430.54
April	0.00	0.00	0.00	0.00	0.00	0.00
May	0.00	0.00	0.00	0.00	0.00	0.00
June	0.00	0.00	0.00	0.00	0.00	0.00
YTD	35,573,195.95	1,954,385.52	6,142,321.90	438,974.70	0.00	44,108,878.07

Table 8: Revenue by Fund - Monthly

Monthly Revenue by Fund	Education Fund	Operations & Maint Fund	Debt Service Fund or Fund Group	Transportation Fund	I.M.R.F./Soc. Sec. Fund	Capital Projects Fund or Fund	Working Cash Fund	Tort Immunity and	Fire Prevention & Safety Fund	Total
July	4,483,672.81	673,130.09	1,262,516.86	598,461.31	162,289.15	3,017.42	129,867.26	184,128.67	121,245.14	7,739,867.65
August	2,155,176.22	200,145.49	367,563.03	95,788.89	43,203.00	13,868.14	36,743.05	60,731.98	35,484.53	3,042,216.80
September	4,823,244.52	726,249.20	1,488,957.53	350,513.42	161,158.43	512.16	132,547.71	214,878.58	141,946.28	8,109,060.38
October	7,037,144.43	1,193,554.55	2,311,490.94	798,826.49	285,269.15	18,714.18	219,474.26	324,630.44	219,311.82	12,475,047.81
November	1,797,793.73	160,292.33	291,140.35	83,168.02	31,617.62	9,090.27	28,332.10	49,456.54	28,174.91	2,504,007.38
December	1,666,977.44	556,651.63	217,829.90	62,302.26	31,638.55	99.85	21,334.65	39,372.13	21,172.21	2,667,349.07
January	4,263,290.04	142,141.35	21,032.08	280,548.46	31,504.00	30,636.12	2,252.72	12,051.94	2,090.28	4,827,847.26
February	1,071,114.63	16,510.78	5,206.74	11,636.71	58.96	5,380.27	202.22	9,144.57	9.58	1,138,051.18
March	1,282,264.99	91,107.30	449.22	11,785.96	38,491.33	14,286.73	788.25	9,267.11	123.39	1,605,430.54
April	0.00	0.00	0.00	0.00	0.00	0.00	0.00	0.00	0.00	0.00
May	0.00	0.00	0.00	0.00	0.00	0.00	0.00	0.00	0.00	0.00
June	0.00	0.00	0.00	0.00	0.00	0.00	0.00	0.00	0.00	0.00
YTD	28,580,678.81	3,759,782.72	5,966,186.65	2,293,031.52	785,230.19	95,605.14	571,542.22	903,661.96	569,558.14	44,108,878.07

Table 9: Revenue by Fund; Budget vs. Year to Date and Three Year History

Annual Revenue Summary by Fund	Budget 2021-2022	Actual Year to Date 2021-2022	Percent of Budget Expended	Actual Year End		
				2020-2021	2019-2020	2018-2019
10 - Education Fund	37,809,332.67	28,580,678.81	75.59%	33,859,587.81	29,428,651.33	28,243,599.92
11 - Activity Fund	200,000.00	583,600.72	291.80%	184,951.36	0.00	0.00
20 - Operations & Maint Fund	6,108,488.64	3,759,782.72	61.55%	4,260,424.45	4,082,991.73	4,238,088.51
30 - Debt Service Fund or Fund Group	8,854,007.76	5,966,186.65	67.38%	8,206,006.73	8,669,972.93	10,094,819.01
40 - Transportation Fund	2,992,698.79	2,293,031.52	76.62%	3,017,426.77	2,967,996.39	2,943,457.51
50 - I.M.R.F./Soc. Sec. Fund	1,074,209.49	785,230.19	73.10%	1,010,197.30	1,066,904.00	1,024,802.96
60 - Capital Projects Fund or Fund Group	296,600.00	95,605.14	32.23%	277,881.20	185,282.36	1,509,512.00
70 - Working Cash Fund	857,541.05	571,542.22	66.65%	793,663.47	1,040,442.96	12,216,820.45
80 - Tort Immunity and Judgment Fund	1,381,714.85	903,661.96	65.40%	1,287,598.09	1,242,599.63	1,272,707.85
90 - Fire Prevention & Safety Fund	853,441.05	569,558.14	66.74%	747,985.94	797,257.24	9,515,433.74
Total	60,428,034.30	44,108,878.07	72.99%	53,645,723.12	49,482,098.57	71,059,241.95

Table 10: Monthly Cash Report

Month: March 2022 Monthly Cash & Investment Report												
	Education	Oper/Maint	Debt Service	Trans portation	IMFR/Soc Sec	Capital	Working Cash	Tort	Life & Safety	Total	Activities	Total All Funds
Checking	507,709	78,478	48,999	64,382	100,989	230,961	82,380	64,331	25,595	1,203,823	506,569	1,710,392
Food Service	1,034,779	-	-	-	-	-	-	-	-	1,034,779	-	1,034,779
Imprest	32,238	100	-	15,174	-	-	-	-	-	47,512	-	47,512
Insurance	1,680,570	303,230	-	35,675	-	-	-	(35,269)	-	1,984,205	-	1,984,205
PMA Cash Account	1,254,273	1,917,017	(210,658)	3,268,827	(57,708)	225,000	2,850,566	1,528,634	1,565,480	12,341,430	-	12,341,430
IPTIP	2,159,663	1,251,058	-	-	536,198	-	204,144	-	-	4,151,063	-	4,151,063
Total Cash Accounts	6,669,232	3,549,882	(161,660)	3,384,057	579,479	455,961	3,137,089	1,557,695	1,591,076	20,762,812	506,569	21,269,381
Total Investments	7,587,219	2,129,502	3,655,035	1,370,860	373,093	6,148,859	12,899,163	733,734	738,183	35,635,647	361,387	35,997,034
Total Cash & Investments	14,256,451	5,679,385	3,493,375	4,754,917	952,572	6,604,819	16,036,253	2,291,429	2,329,259	56,398,459	867,956	57,266,415

Payroll Summaries

Payroll Run Description: 03.30.22 Payroll; Trans Incentive 3/30/2022; Incentive

COUNTY OF GRUNDY SCHOOL DIST 111

Payroll Run	Pay Gross	Fed Gross	Fed Tax	State Gross	State Tax	SS Gross	SS Tax	Med Gross	Med Tax
3/1/22 - Incentive Pay	955.96	939.80	41.55	939.80	45.17	955.96	59.26	955.96	13.86
3/1/22 - Substitute Bus Drivers	968.38	963.28	0.00	963.28	43.94	968.38	60.04	968.38	14.06
3/3/22 - Additional Pay	1,330.00	1,270.15	79.11	1,270.15	62.87	1,330.00	82.46	1,330.00	19.29
3/15/22 - 03.15.22 Payroll	826,220.79	762,812.44	80,031.52	762,812.44	36,782.48	166,291.53	10,310.10	794,159.36	11,515.32
3/15/22 - Williams, Sharon	125.00	119.37	0.00	119.37	0.91	125.00	7.75	125.00	1.81
3/18/22 - Incentive Korhorn, Mary	125.00	119.37	0.00	119.37	5.91	125.00	7.75	125.00	1.81
3/30/22 - 03.30.22 Payroll	827,957.33	764,631.42	80,294.97	764,631.42	36,874.46	163,807.97	10,156.11	795,820.26	11,539.45
3/30/22 - Trans Incentive	366.25	349.77	0.00	349.77	11.93	366.25	22.70	366.25	5.32
Totals:	1,658,048.71	1,531,205.60	160,447.15	1,531,205.60	73,827.67	333,970.09	20,706.17	1,593,850.21	23,110.92

IMPREST

3/31/2022

	EDUCATION	BUILDING	BOND & INT	TRANSPORTATION	SS/IMRF	TORT	TOTAL
BEG BALANCE	34683.15	100.00	0.00	45174.00	0.00	0.00	79957.15
RECEIPTS	0.00						0.00
DEPOSITS	0.00	0.00		0.00	0.00		0.00
DEPOSITS							0.00
Cash advance girls wrestling	629.50						0.00
							629.50
VOID							
TOTAL RECEIPTS	629.50	0.00	0.00	0.00	0.00	0.00	629.50
DISBURSEMENTS	0.00			30000.00			
	0	0.00		0.00			0.00
	1437.00						
Kane County Cougar Field Trip	1638.00						
	0.00						
	0.00						
	0.00						
	0.00			0.00			
	0.00						
	0.00						
	0.00						
TOTAL DISBURSEMENTS	3075.00	0.00	0.00	30000.00	0.00	0.00	33075.00
ENDING BALANCE	32237.65	100.00	0.00	15174.00	0.00	0.00	47511.65
BANK BALANCE	52813.03			LEDGER BALANCE	47511.65		
OUTSTANDING CHECKS	4168.10			OUTSTANDING CHECKS	4168.10		
DIFFERENCE	1133.28			VOID			
REGISTER BALANCE	47511.65	BALANCE		DIFFERENCE	1133.28		
				BANK BALANCE	52813.03	BALANCE	

Balance Sheet Detail by Fund

March 2021-2022		COUNTY OF GRUNDY SCHOOL DIST 111				
Fund	Account	Account Description	Beginning Balance	Debit	Credit	Ending Balance
11 - Activity Fund						
A - Asset						
	11 A 1260 0000 00 000 000000	CASH-ACTIVITIES	\$400,850.84	\$159,602.03	\$53,883.91	\$506,568.96
	11 A 1261 0000 00 000 000000	COADY SCHOLARSHIP	\$361,371.15	\$31.58	\$15.79	\$361,386.94
Totals for: 11 A - Asset			\$762,221.99	\$159,633.61	\$53,899.70	\$867,955.90
L - Liability						
	11 L 4310 0000 00 000 000000	AP Liability	\$0.00	\$54,383.91	\$54,383.91	\$0.00
Totals for: 11 L - Liability			\$0.00	\$54,383.91	\$54,383.91	\$0.00
Q - Equity						
	11 Q 7130 0000 00 000 000000		(\$55,253.02)	\$15,692.26	\$4,022.18	(\$43,582.94)
	11 Q 7131 0000 00 000 000000		\$55,253.02	\$4,022.18	\$15,692.26	\$43,582.94
	11 Q 7150 0000 01 000 900000	COADY SCHOLARSHIP	(\$386,371.15)	\$15.79	\$31.58	(\$386,386.94)
	11 Q 7150 0000 30 300 910001	SPORTS - ATHLETIC HALL OF FAME	(\$5,460.86)	\$0.00	\$0.00	(\$5,460.86)
	11 Q 7150 0000 30 300 910002	SPORTS - ATHLETIC POP	(\$3,775.98)	\$650.00	\$718.83	(\$3,844.81)
	11 Q 7150 0000 30 300 910003	SPORTS - ATHLETIC TRAINING	(\$1,210.82)	\$0.00	\$0.00	(\$1,210.82)
	11 Q 7150 0000 30 300 910004	SPORTS - BASEBALL	(\$17,548.63)	\$156.00	\$0.00	(\$17,392.63)
	11 Q 7150 0000 30 300 910005	SPORTS - BOYS BASKETBALL	(\$17,509.20)	\$1,808.10	\$107.00	(\$15,808.10)
	11 Q 7150 0000 30 300 910006	SPORTS - BOYS BOWLING	(\$1,173.05)	\$0.00	\$0.00	(\$1,173.05)
	11 Q 7150 0000 30 300 910007	SPORTS - BOYS GOLF	(\$2,497.18)	\$0.00	\$0.00	(\$2,497.18)
	11 Q 7150 0000 30 300 910008	SPORTS - BOYS SOCCER	(\$4,350.43)	\$0.00	\$5,510.00	(\$9,860.43)
	11 Q 7150 0000 30 300 910009	SPORTS - BOYS TENNIS	(\$3,073.10)	\$0.00	\$2,459.00	(\$5,532.10)

Balance Sheet Detail by Fund

March 2021-2022		COUNTY OF GRUNDY SCHOOL DIST 111				
Fund	Account	Account Description	Beginning Balance	Debit	Credit	Ending Balance
11 - Activity Fund						
Q - Equity						
	11 Q 7150 0000 30 300 910010	SPORTS - BOYS TRACK	(\$6,271.76)	\$392.30	\$1,294.85	(\$7,174.31)
	11 Q 7150 0000 30 300 910011	SPORTS - BOYS VOLLEYBALL	(\$6,703.17)	\$48.00	\$48.00	(\$6,703.17)
	11 Q 7150 0000 30 300 910012	SPORTS - CHEERLEADERS	(\$11,890.41)	\$3,299.80	\$0.00	(\$8,590.61)
	11 Q 7150 0000 30 300 910013	SPORTS - CROSS COUNTY CO ED	(\$8,772.53)	\$4,524.07	\$0.00	(\$4,248.46)
	11 Q 7150 0000 30 300 910014	SPORTS - FOOTBALL	(\$35,776.66)	\$1,849.94	\$4,794.00	(\$38,720.72)
	11 Q 7150 0000 30 300 910015	SPORTS - FOOTBALL JERSEYS	(\$2,741.97)	\$0.00	\$0.00	(\$2,741.97)
	11 Q 7150 0000 30 300 910016	SPORTS - GIRLS BASKETBALL	(\$11,756.81)	\$0.00	\$107.00	(\$11,863.81)
	11 Q 7150 0000 30 300 910017	SPORTS - GIRLS BOWLING	(\$3,646.57)	\$289.16	\$15.23	(\$3,372.64)
	11 Q 7150 0000 30 300 910018	SPORTS - GIRLS GOLF	(\$1,413.85)	\$0.00	\$0.00	(\$1,413.85)
	11 Q 7150 0000 30 300 910019	SPORTS - GIRLS SOCCER	(\$879.10)	\$0.00	\$0.00	(\$879.10)
	11 Q 7150 0000 30 300 910020	SPORTS - GIRLS TENNIS	(\$3,213.70)	\$0.00	\$0.00	(\$3,213.70)
	11 Q 7150 0000 30 300 910021	SPORTS - GIRLS TRACK	(\$3,186.64)	\$1,240.61	\$0.00	(\$1,946.03)
	11 Q 7150 0000 30 300 910022	SPORTS - GIRLS VOLLEYBALL	(\$9,816.73)	\$0.00	\$0.00	(\$9,816.73)
	11 Q 7150 0000 30 300 910023	SPORTS - LACROSSE	(\$513.64)	\$0.00	\$456.74	(\$970.38)
	11 Q 7150 0000 30 300 910024	SPORTS - OUTDOOR ED TRIP	(\$5,212.00)	\$0.00	\$0.00	(\$5,212.00)
	11 Q 7150 0000 30 300 910025	SPORTS - POMS	(\$21,075.28)	\$9,315.40	\$146.44	(\$11,906.32)
	11 Q 7150 0000 30 300 910026	SPORTS - SOFTBALL	\$0.00	\$2,515.26	\$2,199.00	\$316.26
	11 Q 7150 0000 30 300 910027	SPORTS - SWIMMING B&G	(\$760.49)	\$0.00	\$0.00	(\$760.49)

Balance Sheet Detail by Fund

March 2021-2022		COUNTY OF GRUNDY SCHOOL DIST 111				
Fund	Account	Account Description	Beginning Balance	Debit	Credit	Ending Balance
11 - Activity Fund						
Q - Equity						
	11 Q 7150 0000 30 300 910028	SPORTS - WRESTLING	(\$7,718.32)	\$1,142.00	\$0.00	(\$6,576.32)
	11 Q 7150 0000 30 300 910037	SUMMER CAMPS - GIRLS VOLLEYBALL	\$40.00	\$0.00	\$0.00	\$40.00
	11 Q 7150 0000 30 300 910038	SUMMER CAMPS - POMS	(\$1,061.00)	\$0.00	\$0.00	(\$1,061.00)
	11 Q 7150 0000 70 300 900001	ACTIVITIES - POP	(\$5,050.99)	\$1,202.83	\$646.85	(\$4,495.01)
	11 Q 7150 0000 70 300 900002	ACTIVITIES - ART CLUB	(\$692.10)	\$0.00	\$0.00	(\$692.10)
	11 Q 7150 0000 70 300 900003	ACTIVITIES - ATHLETIC LEADERSHIP	(\$342.50)	\$0.00	\$0.00	(\$342.50)
	11 Q 7150 0000 70 300 900004	ACTIVITIES - BAND	(\$216.00)	\$282.56	\$0.00	\$66.56
	11 Q 7150 0000 70 300 900005	ACTIVITIES - CHESS	(\$5.00)	\$0.00	\$338.00	(\$343.00)
	11 Q 7150 0000 70 300 900006	ACTIVITIES - CHOIR PROJECTS	(\$62.29)	\$0.00	\$0.00	(\$62.29)
	11 Q 7150 0000 70 300 900007	ACTIVITIES - CHORUS	(\$2,446.82)	\$0.00	\$0.00	(\$2,446.82)
	11 Q 7150 0000 70 300 900011	ACTIVITIES - CLASS OF 2022	(\$5,240.11)	\$0.00	\$11.48	(\$5,251.59)
	11 Q 7150 0000 70 300 900012	ACTIVITIES - CLASS OF 2023	(\$2,995.69)	\$0.00	\$11.48	(\$3,007.17)
	11 Q 7150 0000 70 300 900013	ACTIVITIES - CLASS OF 2024	(\$697.68)	\$597.63	\$4,985.00	(\$5,085.05)
	11 Q 7150 0000 70 300 900014	ACTIVITIES - COMMUNITY GARDEN	(\$615.39)	\$0.00	\$0.00	(\$615.39)
	11 Q 7150 0000 70 300 900015	ACTIVITIES - CULINARY ARTS	(\$816.30)	\$0.00	\$60.66	(\$876.96)
	11 Q 7150 0000 70 300 900017	ACTIVITIES - DREAM	(\$500.90)	\$0.00	\$0.00	(\$500.90)
	11 Q 7150 0000 70 300 900018	ACTIVITIES - FASHION MERCHANDISING	(\$223.31)	\$0.00	\$0.00	(\$223.31)
	11 Q 7150 0000 70 300 900019	ACTIVITIES - FCCLA	(\$187.80)	\$0.00	\$0.00	(\$187.80)

Balance Sheet Detail by Fund

March 2021-2022		COUNTY OF GRUNDY SCHOOL DIST 111				
Fund	Account	Account Description	Beginning Balance	Debit	Credit	Ending Balance
11 - Activity Fund						
	Q - Equity					
	11 Q 7150 0000 70 300 900020	ACTIVITIES - FFA	(\$4,139.22)	\$0.00	\$2,036.00	(\$6,175.22)
	11 Q 7150 0000 70 300 900021	ACTIVITIES - FRENCH NHS	(\$305.91)	\$0.00	\$0.00	(\$305.91)
	11 Q 7150 0000 70 300 900022	ACTIVITIES - FUTURE BUSINESS LEADERS	(\$140.86)	\$0.00	\$0.00	(\$140.86)
	11 Q 7150 0000 70 300 900023	ACTIVITIES - I.O.T.A.	(\$2,745.38)	\$0.00	\$0.00	(\$2,745.38)
	11 Q 7150 0000 70 300 900024	ACTIVITIES - INDIAN CLIMBING CLUB	(\$186.80)	\$0.00	\$0.00	(\$186.80)
	11 Q 7150 0000 70 300 900025	ACTIVITIES - INDIAN NATION	(\$90.21)	\$0.00	\$0.00	(\$90.21)
	11 Q 7150 0000 70 300 900026	ACTIVITIES - INT'L CLUB	\$2,147.72	\$568.29	\$0.00	\$2,716.01
	11 Q 7150 0000 70 300 900027	ACTIVITIES - INT'L THESPIANS	(\$16,549.14)	\$1,663.40	\$0.00	(\$14,885.74)
	11 Q 7150 0000 70 300 900028	ACTIVITIES - INTERACT	(\$176.55)	\$0.00	\$0.00	(\$176.55)
	11 Q 7150 0000 70 300 900029	ACTIVITIES - INVESTMENT CLUB	(\$108.16)	\$0.00	\$0.00	(\$108.16)
	11 Q 7150 0000 70 300 900030	ACTIVITIES - JUDO	(\$13,950.21)	\$0.00	\$0.00	(\$13,950.21)
	11 Q 7150 0000 70 300 900031	ACTIVITIES - KALEIDOSOPE	(\$1,094.07)	\$0.00	\$0.00	(\$1,094.07)
	11 Q 7150 0000 70 300 900032	ACTIVITIES - MAC	(\$11,717.68)	\$3,124.41	\$1,313.73	(\$9,907.00)
	11 Q 7150 0000 70 300 900033	ACTIVITIES - MATH TEAM	(\$6.00)	\$0.00	\$240.00	(\$246.00)
	11 Q 7150 0000 70 300 900034	ACTIVITIES - MCHS BOOK CLUB	(\$598.77)	\$0.00	\$0.00	(\$598.77)
	11 Q 7150 0000 70 300 900035	ACTIVITIES - MEMORIAL GARDEN	(\$888.23)	\$0.00	\$0.00	(\$888.23)
	11 Q 7150 0000 70 300 900036	ACTIVITIES - MUSICAL	(\$4,481.11)	\$41.95	\$660.00	(\$5,099.16)
	11 Q 7150 0000 70 300 900037	ACTIVITIES - NEEDY FAMILIES	(\$4,067.03)	\$0.00	\$0.00	(\$4,067.03)

Balance Sheet Detail by Fund

March 2021-2022		COUNTY OF GRUNDY SCHOOL DIST 111				
Fund	Account	Account Description	Beginning Balance	Debit	Credit	Ending Balance
11 - Activity Fund						
Q - Equity						
	11 Q 7150 0000 70 300 900038	ACTIVITIES - NHS	(\$2,280.50)	\$1,673.02	\$0.00	(\$607.48)
	11 Q 7150 0000 70 300 900039	ACTIVITIES - ORCHESTRIS	(\$4,593.00)	\$51.80	\$716.28	(\$5,257.48)
	11 Q 7150 0000 70 300 900040	ACTIVITIES - PAC RESTORATION	(\$1,733.88)	\$0.00	\$2,012.00	(\$3,745.88)
	11 Q 7150 0000 70 300 900041	ACTIVITIES - PERCUSSION	(\$10,400.86)	\$9,555.05	\$3,864.40	(\$4,710.21)
	11 Q 7150 0000 70 300 900043	ACTIVITIES - NEWSPAPER	(\$392.26)	\$0.00	\$0.00	(\$392.26)
	11 Q 7150 0000 70 300 900044	ACTIVITIES - SADD	(\$381.95)	\$0.00	\$0.00	(\$381.95)
	11 Q 7150 0000 70 300 900045	ACTIVITIES - SCHOLASTIC BOWL	(\$307.53)	\$0.00	\$200.00	(\$507.53)
	11 Q 7150 0000 70 300 900046	ACTIVITIES - SPANISH NHS	(\$1,306.32)	\$0.00	\$0.00	(\$1,306.32)
	11 Q 7150 0000 70 300 900047	ACTIVITIES - SPEECH	(\$3,421.73)	\$0.00	\$0.00	(\$3,421.73)
	11 Q 7150 0000 70 300 900048	ACTIVITIES - STUDENT COUNCIL	(\$42,028.53)	\$1,317.04	\$3.18	(\$40,714.67)
	11 Q 7150 0000 70 300 900049	ACTIVITIES - TSA	(\$2,901.06)	\$0.00	\$0.00	(\$2,901.06)
	11 Q 7150 0000 70 300 900050	ACTIVITIES - UNDERWATER ROBOTIC	(\$711.54)	\$231.00	\$2,341.76	(\$2,822.30)
	11 Q 7150 0000 70 300 900051	ACTIVITIES - WINTERGUARD	(\$5,760.63)	\$5,843.84	\$9,731.83	(\$9,648.62)
	11 Q 7150 0000 70 300 900052	ACTIVITIES - WYSE	(\$418.94)	\$0.00	\$0.00	(\$418.94)
	11 Q 7150 0000 70 300 900053	ACTIVITIES - YEARBOOK	(\$29,743.88)	\$0.00	\$191.26	(\$29,935.14)
	11 Q 7150 0000 70 300 900055	CYBRARY	(\$1,238.29)	\$0.00	\$0.00	(\$1,238.29)
	11 Q 7150 0000 70 300 900056	FACULTY POP	(\$2,266.37)	\$0.00	\$68.83	(\$2,335.20)
	11 Q 7150 0000 70 300 900057	PROJECT INDIAN	(\$2,085.53)	\$0.00	\$0.00	(\$2,085.53)

Balance Sheet Detail by Fund

March	2021-2022	COUNTY OF GRUNDY SCHOOL DIST 111				
Fund	Account	Account Description	Beginning Balance	Debit	Credit	Ending Balance
11 - Activity Fund						
	Q - Equity					
	11 Q 7150 0000 70 300 900058	PROM	(\$8,088.75)	\$0.00	\$105,415.00	(\$113,503.75)
	11 Q 7150 0000 70 300 900059	SCHOLARSHIP	\$24,250.09	\$0.00	\$2,000.00	\$22,250.09
	11 Q 7150 0000 70 300 900060	TV PRODUCTION	(\$10.60)	\$0.00	\$0.00	(\$10.60)
	11 Q 7150 0000 70 300 900061	ASL - AMERICAN SIGN LANGUAGE CLUB	(\$748.79)	\$0.00	\$0.00	(\$748.79)
	11 Q 7150 0000 70 300 900062	GREEN HOUSE	(\$921.75)	\$0.00	\$0.00	(\$921.75)
	11 Q 7150 0000 70 300 900063	CLASS OF 2025	(\$197.87)	\$587.25	\$4,985.00	(\$4,595.62)
Totals for: 11 Q - Equity			(\$762,221.99)	\$73,700.94	\$179,434.85	(\$867,955.90)
Totals for Fund: 11 - Activity Fund			\$0.00	\$287,718.46	\$287,718.46	\$0.00
			Account			
			Beginning Balance	Debit	Credit	Ending Balance
Totals for: Asset			\$762,221.99	\$159,633.61	\$53,899.70	\$867,955.90
Totals for: Liability			\$0.00	\$54,383.91	\$54,383.91	\$0.00
Totals for: Equity			(\$762,221.99)	\$73,700.94	\$179,434.85	(\$867,955.90)
Grand Totals:			\$0.00	\$287,718.46	\$287,718.46	\$0.00

Revenue Report

Fiscal Year: 2021-2022
Month: March

COUNTY OF GRUNDY SCHOOL DIST 111

Fund Description	Account Number	Account Description	Revised Budget	Monthly Activity	Pending Activity	Available Funds	Year to Date Activity	Percent of Budget Used
Education Fund	10 R 1110 0000 00 000 000000	PRIOR YEAR TAXES	0.00	0.00		0.00	0.00	0.00
Education Fund	10 R 1111 0000 00 000 000000	GRUNDY CO TAXES	7,292,016.00	0.00	0.00	170,727.08	7,121,288.92	97.66
Education Fund	10 R 1112 0000 00 000 000000	KENDALL CO TAXES	1,031,061.24	0.00	0.00	12,124.39	1,018,936.85	98.82
Education Fund	10 R 1113 0000 00 000 000000	WILL CO TAXES	5,698,988.00	0.00	0.00	-34,463.31	5,733,451.31	100.60
Education Fund	10 R 1114 0000 00 000 000000	GRUNDY CO EDPA SURPLUS	0.00	0.00	0.00	-672,615.32	672,615.32	0.00
Education Fund	10 R 1122 0000 00 000 000000	KENDALL CO - EARLY DISTR	1,153,484.00	0.00		1,153,484.00	0.00	0.00
Education Fund	10 R 1123 0000 00 000 000000	WILL CO - EARLY DISTR	5,570,354.00	0.00		5,570,354.00	0.00	0.00
Education Fund	10 R 1210 0000 00 000 000000	MOBILE HOME TAX	0.00	0.00		0.00	0.00	0.00
Education Fund	10 R 1211 0000 00 000 000000	MOBILE HOME TAX SPECIAL ED	0.00	0.00		0.00	0.00	0.00
Education Fund	10 R 1211 0000 00 000 000001	GRUNDY CO TORT	0.00	0.00		0.00	0.00	0.00
Education Fund	10 R 1212 0000 00 000 000000	MOBILE HOME TAX - LEASE	0.00	0.00		0.00	0.00	0.00
Education Fund	10 R 1212 0000 00 000 000001	KENDALL CO TORT	0.00	0.00		0.00	0.00	38 0.00
Education Fund	10 R 1213 0000 00 000 000000	WILL CO TORT	0.00	0.00		0.00	0.00	0.00
Education Fund	10 R 1222 0000 00 000 000000	KENDALL CO TORT-EARLY DISTR	0.00	0.00		0.00	0.00	0.00
Education Fund	10 R 1223 0000 00 000 000000	WILL CO TORT-EARLY DISTR	0.00	0.00		0.00	0.00	0.00
Education Fund	10 R 1230 0000 00 000 000000	CPPRT	567,435.00	168,623.56	0.00	-39,165.44	606,600.44	106.90
Education Fund	10 R 1290 0000 00 000 000000	PAYMENTS IN LIEU OF TAXES	0.00	0.00		0.00	0.00	0.00
Education Fund	10 R 1291 0000 00 000 000000	LAG FEES	0.00	0.00		0.00	0.00	0.00
Education Fund	10 R 1292 0000 00 000 000000	PAYMENT IN LIEU OF TAXES SP ED	0.00	0.00		0.00	0.00	0.00
Education Fund	10 R 1293 0000 00 000 000000	PAYMENT IN LIEU OF TAXES LEASE	0.00	0.00		0.00	0.00	0.00
Education Fund	10 R 1311 0000 00 000 000000	NON-RESIDENT TUITION	12,000.00	0.00		12,000.00	0.00	0.00
Education Fund	10 R 1311 0000 00 000 000001	GRUNDY CO LEASE	187,261.00	0.00	0.00	4,386.87	182,874.13	97.66
Education Fund	10 R 1312 0000 00 000 000000	KENDALL CO LEASE	27,692.43	0.00	0.00	598.72	27,093.71	97.84
Education Fund	10 R 1313 0000 00 000 000000	WILL CO LEASE	147,931.00	0.00	0.00	1,774.99	146,156.01	98.80
Education Fund	10 R 1314 0000 00 000 000000	GRUNDY CO LEASE EDPA SURPLUS	0.00	0.00		0.00	0.00	0.00
Education Fund	10 R 1321 0000 00 000 000000	TOTAL SUMMER SCHOOL TUITION	0.00	0.00		0.00	0.00	0.00

Revenue Report

Fiscal Year: 2021-2022
Month: March

COUNTY OF GRUNDY SCHOOL DIST 111

Fund Description	Account Number	Account Description	Revised Budget	Monthly Activity	Pending Activity	Available Funds	Year to Date Activity	Percent of Budget Used
Education Fund	10 R 1322 0000 00 000 000000	KENDALL CO LEASE-EARLY DISTR	0.00	0.00		0.00	0.00	0.00
Education Fund	10 R 1323 0000 00 000 000000	WILL CO LEASE-EARLY DISTR	141,997.00	0.00		141,997.00	0.00	0.00
Education Fund	10 R 1411 0000 00 000 000000	GRUNDY CO SPEC ED	119,541.00	0.00	0.00	2,798.55	116,742.45	97.66
Education Fund	10 R 1411 0000 00 000 000001	GRUNDY CO SPEC ED TIF	0.00	0.00		0.00	0.00	0.00
Education Fund	10 R 1412 0000 00 000 000000	KENDALL CO SPEC ED	17,074.00	0.00	0.00	370.11	16,703.89	97.83
Education Fund	10 R 1413 0000 00 000 000000	WILL CO SPEC ED	92,974.00	0.00	0.00	-1,017.01	93,991.01	101.09
Education Fund	10 R 1414 0000 00 000 000000	GRUNDY CO SPEC ED EDPA SURPLUS	0.00	0.00		0.00	0.00	0.00
Education Fund	10 R 1422 0000 00 000 000000	KENDALL CO SPEC ED-EARLY DISTR	18,909.00	0.00		18,909.00	0.00	0.00
Education Fund	10 R 1423 0000 00 000 000000	WILL CO SPEC ED-EARLY DISTR	91,317.00	0.00		91,317.00	0.00	0.00
Education Fund	10 R 1510 0000 00 000 000000	CHECKING INTEREST	0.00	0.00		0.00	0.00	0.00
Education Fund	10 R 1511 0000 00 000 000000	INVESTMENT INTEREST	27,000.00	1,620.52	0.00	22,020.96	4,979.04	18.44
Education Fund	10 R 1611 0000 00 000 000000	CAFETERIA SALES CASH	275,000.00	24,811.89	-642.20	83,053.90	192,588.30	70.03
Education Fund	10 R 1612 0000 00 000 000000	CAFETERIA SALES CREDIT CARD	575,000.00	107,028.22	0.00	-139,506.67	714,506.67	124.26
Education Fund	10 R 1620 0000 00 000 000000	COFFEE SALES	0.00	0.00		0.00	0.00	0.00
Education Fund	10 R 1709 0000 00 000 000000	POST SEASON GATE RECEIPTS	1,000.00	6,376.00	0.00	-20,271.50	21,271.50	2,127.15
Education Fund	10 R 1710 0000 00 000 000000	ATHLETIC ENTRY FEES RECD	1,500.00	4,735.00	0.00	-15,735.00	17,235.00	1,149.00
Education Fund	10 R 1711 0000 00 000 000000	SOCCER ADMISSIONS	0.00	0.00		0.00	0.00	0.00
Education Fund	10 R 1712 0000 00 000 000000	FOOTBALL ADMISSIONS	6,000.00	0.00	0.00	-8,029.90	14,029.90	233.83
Education Fund	10 R 1713 0000 00 000 000000	XC ADMISSIONS	0.00	0.00		0.00	0.00	0.00
Education Fund	10 R 1714 0000 00 000 000000	WRESTLING ADMISSIONS	500.00	0.00	0.00	-1,269.00	1,769.00	353.80
Education Fund	10 R 1715 0000 00 000 000000	BOYS BASKETBALL ADMISSIONS	500.00	0.00	0.00	-4,229.00	4,729.00	945.80
Education Fund	10 R 1716 0000 00 000 000000	GIRLS BSKTBLL ADMISSIONS	500.00	0.00	0.00	-1,340.00	1,840.00	368.00
Education Fund	10 R 1717 0000 00 000 000000	VOLLEYBALL ADMISSIONS	500.00	368.00	0.00	-1,979.00	2,479.00	495.80
Education Fund	10 R 1718 0000 00 000 000000	SPORT PASSES	0.00	0.00	0.00	-7,160.00	7,160.00	0.00
Education Fund	10 R 1719 0000 00 000 000000	TRACK ADMISSIONS	0.00	0.00		0.00	0.00	0.00
Education Fund	10 R 1720 0000 00 000 000000	DRIVER EDUC FEES	0.00	875.00	0.00	-16,475.00	16,475.00	0.00

39

Revenue Report

Fiscal Year: 2021-2022
Month: March

COUNTY OF GRUNDY SCHOOL DIST 111

Fund Description	Account Number	Account Description	Revised Budget	Monthly Activity	Pending Activity	Available Funds	Year to Date Activity	Percent of Budget Used
Education Fund	10 R 1721 0000 00 000 000000	LOCK FEES	0.00	6.00	0.00	-7,137.00	7,137.00	0.00
Education Fund	10 R 1722 0000 00 000 000000	MISCELLANEOUS FEES	169,990.00	9,166.07	0.00	121,684.08	48,305.92	28.42
Education Fund	10 R 1723 0000 00 000 000000	P.E. UNIFORMS	0.00	0.00	0.00	-3,082.00	3,082.00	0.00
Education Fund	10 R 1724 0000 00 000 000000	STUDENT PARKING FEES	95,000.00	1,162.00	0.00	-7,627.00	102,627.00	108.03
Education Fund	10 R 1725 0000 00 000 000000	BOWLING ADMISSIONS	0.00	0.00	0.00	-445.00	445.00	0.00
Education Fund	10 R 1726 0000 00 000 000000	SPRING MUSICAL ADMISSIONS	1,500.00	9,330.00	0.00	-16,051.00	17,551.00	1,170.07
Education Fund	10 R 1727 0000 00 000 000000	FALL PLAY ADMISSIONS	2,000.00	0.00	0.00	437.98	1,562.02	78.10
Education Fund	10 R 1728 0000 00 000 000000	STUDENT PURCHASES	0.00	0.00		0.00	0.00	0.00
Education Fund	10 R 1729 0000 00 000 000000	INVITE ADMISSIONS	100.00	0.00		100.00	0.00	0.00
Education Fund	10 R 1730 0000 00 000 000000	MADRIGALS ADMISSIONS	500.00	25.00	0.00	475.00	25.00	5.00
Education Fund	10 R 1731 0000 00 000 000000	ACTIVITY MISC	600.00	0.00		600.00	0.00	0.00
Education Fund	10 R 1732 0000 00 000 000000	SPORT PASSES	500.00	0.00		500.00	0.00	0.00
Education Fund	10 R 1733 0000 00 000 000000	LACROSSE ADMISSIONS	0.00	0.00		0.00	0.00	40 0.00
Education Fund	10 R 1790 0000 00 000 000000	OTHER PUPIL ACT REVENUE	0.00	0.00		0.00	0.00	0.00
Education Fund	10 R 1811 0000 00 000 000000	TEXTBOOK FEES	610,000.00	32,876.31	0.00	-172,737.84	782,737.84	128.32
Education Fund	10 R 1825 0000 00 000 000000	AP TESTING FEE	0.00	0.00		0.00	0.00	0.00
Education Fund	10 R 1826 0000 00 000 000000	SAT TESTING FEES	5,000.00	0.00	0.00	-1,406.00	6,406.00	128.12
Education Fund	10 R 1827 0000 00 000 000000	SALE OF EQUIPMENT	500.00	0.00	0.00	-4,395.00	4,895.00	979.00
Education Fund	10 R 1828 0000 00 000 000000	A/P TEST FEES	65,000.00	-94.00	0.00	14,360.00	50,640.00	77.91
Education Fund	10 R 1829 0000 00 000 000000	MATH RESALE REVENUE	0.00	0.00		0.00	0.00	0.00
Education Fund	10 R 1920 0000 00 000 000000	IMTT GRANT	0.00	0.00		0.00	0.00	0.00
Education Fund	10 R 1950 0000 00 000 000000	REFUND OF PRIOR YR EXPENSES	44,000.00	0.00		44,000.00	0.00	0.00
Education Fund	10 R 1970 0000 00 000 000000	DR ED FEES	40,000.00	0.00	0.00	21,100.00	18,900.00	47.25
Education Fund	10 R 1971 0000 00 000 000000	SUMMER DR ED FEES	30,000.00	1,400.00	0.00	1,625.00	28,375.00	94.58
Education Fund	10 R 1993 0000 00 000 000000	WELLNESS CENTER	0.00	0.00		0.00	0.00	0.00
Education Fund	10 R 1998 0000 00 000 000000	EDUCATION FOUNDATION GRANTS	5,000.00	0.00	0.00	2,302.49	2,697.51	53.95
Education Fund	10 R 1999 0000 00 000 000000	OTHER-LOCAL SOURCES	115,000.00	23,038.32	0.00	-154,371.44	269,371.44	234.24

Revenue Report

Fiscal Year: 2021-2022
Month: March

COUNTY OF GRUNDY SCHOOL DIST 111

Fund Description	Account Number	Account Description	Revised Budget	Monthly Activity	Pending Activity	Available Funds	Year to Date Activity	Percent of Budget Used
Education Fund	10 R 1999 2220 00 000 000000	DIST 111 GROUP MEDICAL REVENUE	3,332,919.00	308,680.59	0.00	631,955.77	2,700,963.23	81.04
Education Fund	10 R 1999 2230 00 000 000000	DIST 111 GROUP DENTAL REVENUE	165,000.00	15,661.27	0.00	29,051.80	135,948.20	82.39
Education Fund	10 R 2100 0000 00 000 000000	ECO LAB GRANT	0.00	0.00		0.00	0.00	0.00
Education Fund	10 R 2901 0000 00 000 000000	GRUNDY CO EDUCATION TIF	1,804,635.00	0.00	0.00	-149,750.52	1,954,385.52	108.30
Education Fund	10 R 2902 0000 00 000 000000	GRUNDY CO LEASE TIF	0.00	0.00		0.00	0.00	0.00
Education Fund	10 R 2903 0000 00 000 000000	GRUNDY CO SPEC ED TIF	0.00	0.00		0.00	0.00	0.00
Education Fund	10 R 3001 0000 00 000 000000	EVIDENCE BASED FUNDING	6,228,000.00	566,182.00	0.00	1,698,547.00	4,529,453.00	72.73
Education Fund	10 R 3002 0000 00 000 000000	GSA HOLD HARMLESS	0.00	0.00		0.00	0.00	0.00
Education Fund	10 R 3030 0000 00 000 000000	FAST GROWTH GRANTS	0.00	0.00		0.00	0.00	0.00
Education Fund	10 R 3099 0000 00 000 000000	TRANSITION ASSISTANCE	0.00	0.00		0.00	0.00	0.00
Education Fund	10 R 3100 0000 00 000 000000	SPEC ED-PRIVATE FACILITY	700,000.00	0.00	0.00	83,802.47	616,197.53	88.03
Education Fund	10 R 3105 0000 00 000 000000	SPEC ED- EXTRAORDINARY	0.00	0.00		0.00	0.00	0.00
Education Fund	10 R 3110 0000 00 000 000000	SPEC ED- PERSONNEL	0.00	0.00		0.00	0.00	0.00
Education Fund	10 R 3120 0000 00 000 000000	SPEC ED- ORPHANAGE/INDIV	25,000.00	0.00	0.00	29,288.65	-4,288.65	-17.15
Education Fund	10 R 3130 0000 00 000 000000	SP ED ORPHANAGE SUMMER IND	0.00	0.00		0.00	0.00	0.00
Education Fund	10 R 3145 0000 00 000 000000	SPEC ED- SUMMER SCHOOL	0.00	0.00		0.00	0.00	0.00
Education Fund	10 R 3215 0000 00 000 000000	VOC ED-FORMULA	0.00	0.00		0.00	0.00	0.00
Education Fund	10 R 3220 0000 00 000 000000	CAREER/TECH EDUC IMPR GRNT	68,000.00	0.00	0.00	-4,085.00	72,085.00	106.01
Education Fund	10 R 3225 0000 00 000 000000	VOC ED FORMULA REIMB.	0.00	0.00		0.00	0.00	0.00
Education Fund	10 R 3226 0000 00 000 000000	VOC ED PROGRAM IMPROVMT.	0.00	0.00		0.00	0.00	0.00
Education Fund	10 R 3235 0000 00 000 000000	VOC ED AG EDUC INCENTIVE	2,000.00	0.00		2,000.00	0.00	0.00
Education Fund	10 R 3305 0000 00 000 000000	BILINGUAL ED-DOWNSTATE	0.00	0.00		0.00	0.00	0.00
Education Fund	10 R 3350 0000 00 000 000000	GIFTED EDUCATION	0.00	0.00		0.00	0.00	0.00
Education Fund	10 R 3360 0000 00 000 000000	STATE FREE LUNCH & BRKFST	1,000.00	63.24	0.00	-7.72	1,007.72	100.77

41

Revenue Report

Fiscal Year: 2021-2022
Month: March

COUNTY OF GRUNDY SCHOOL DIST 111

Fund Description	Account Number	Account Description	Revised Budget	Monthly Activity	Pending Activity	Available Funds	Year to Date Activity	Percent of Budget Used
Education Fund	10 R 3370 0000 00 000 000000	DRIVERS ED REIMBURSEMENT	65,000.00	0.00	0.00	9,321.62	55,678.38	85.66
Education Fund	10 R 3610 0000 00 000 000000	LEARNING IMPR-CHANGE GRNT	0.00	0.00		0.00	0.00	0.00
Education Fund	10 R 3640 0000 00 000 000000	PROF DEVELOP BLOCK GRANT	0.00	0.00		0.00	0.00	0.00
Education Fund	10 R 3696 0000 00 000 000000	REGIONAL SAFE SCHOOLS PROGRAM	60,000.00	0.00		60,000.00	0.00	0.00
Education Fund	10 R 3740 0000 00 000 000000	CRIM BACKGROUND CHECKS	0.00	0.00		0.00	0.00	0.00
Education Fund	10 R 3775 0000 00 000 000000	ADA SAFETY BLOCK GRANT	0.00	0.00		0.00	0.00	0.00
Education Fund	10 R 3781 0000 00 000 000000	TECH INTEGRATION GRANT	0.00	0.00		0.00	0.00	0.00
Education Fund	10 R 3792 0000 00 000 000000	TECH-CLOSING THE GAP	0.00	0.00		0.00	0.00	0.00
Education Fund	10 R 3800 0000 00 000 000000	STATE LIBRARY GRANT	0.00	0.00		0.00	0.00	0.00
Education Fund	10 R 3998 0000 00 000 000000	RECEIPTS/REVENUE ON BEHALF PAYMENTS	0.00	0.00		0.00	0.00	0.00
Education Fund	10 R 3999 0000 00 000 000000	OTH GRANTS-IN-AID/STATE SOURCE	0.00	0.00		0.00	0.00	0.00
Education Fund	10 R 4100 0000 00 000 000000	TITLE V	0.00	0.00		0.00	0.00	0.00
Education Fund	10 R 4101 0000 00 000 000000	HOMELESS GRANT	0.00	0.00		0.00	0.00	0.00
Education Fund	10 R 4215 0000 00 000 000000	SPECIAL MILK PROGRAM	387,000.00	330.00	0.00	385,049.98	1,950.02	0.50
Education Fund	10 R 4225 0000 00 000 000000	Summer Foods Program	0.00	0.00	0.00	0.00	0.00	0.00
Education Fund	10 R 4300 0000 00 000 000000	TITLE I	72,000.00	0.00	0.00	18,442.00	53,558.00	74.39
Education Fund	10 R 4400 0000 00 000 000000	TITLE IV DRUG FREE GRANT	10,000.00	0.00	0.00	535.00	9,465.00	94.65
Education Fund	10 R 4620 0000 00 000 000000	SPEC ED-IDEA FLOW THRU	0.00	0.00		0.00	0.00	0.00
Education Fund	10 R 4625 0000 00 000 000000	SPEC ED-IDEA-RM & BOARD	415,000.00	0.00	0.00	268,016.07	146,983.93	35.42
Education Fund	10 R 4745 0000 00 000 000000	AG EDUC GRANT	1,200.00	0.00	0.00	-70.00	1,270.00	105.83
Education Fund	10 R 4850 0000 00 000 000000	ARRA - GENERAL STATE AID	0.00	0.00		0.00	0.00	0.00
Education Fund	10 R 4870 0000 00 000 000000	ARRA -GSA-SFSF	0.00	0.00		0.00	0.00	0.00
Education Fund	10 R 4880 0000 00 000 000000	ARRA-Educ Jobs Fund Prgm	0.00	0.00		0.00	0.00	0.00
Education Fund	10 R 4930 0000 00 000 000000	TITLE II EISENHWR PROF DVLPMNT	0.00	0.00		0.00	0.00	0.00
Education Fund	10 R 4932 0000 00 000 000000	Title II - Teacher Quality	29,529.00	0.00	0.00	6,431.00	23,098.00	78.22

42

Revenue Report

Fiscal Year: 2021-2022
Month: March

COUNTY OF GRUNDY SCHOOL DIST 111

Fund Description	Account Number	Account Description	Revised Budget	Monthly Activity	Pending Activity	Available Funds	Year to Date Activity	Percent of Budget Used
Education Fund	10 R 4935 0000 00 000 000000	TITLE II EISENHWR MATH/SCI	0.00	0.00		0.00	0.00	0.00
Education Fund	10 R 4971 0000 00 000 000000	TITLE II PART D TECH GRANT	0.00	0.00		0.00	0.00	0.00
Education Fund	10 R 4991 0000 00 000 000000	MEDICAID/ADMN OUTREACH	15,000.00	0.00	0.00	-1,824.75	16,824.75	112.17
Education Fund	10 R 4992 0000 00 000 000000	MEDICAID MATCHING	0.00	0.00		0.00	0.00	0.00
Education Fund	10 R 4998 0000 00 000 499801	DIGITAL EQUITY GRANT	185,825.00	0.00	0.00	0.00	185,825.00	100.00
Education Fund	10 R 7110 0000 00 000 000000	PERM TRANS FROM W/C-ABATEMENT	0.00	0.00		0.00	0.00	0.00
Education Fund	10 R 7180 0000 00 000 000000	PERM TRANS FROM W/C-ABATEMENT	0.00	0.00		0.00	0.00	0.00
Education Fund	10 R 7900 0000 00 000 000000	DEBT PROCEEDS	0.00	0.00		0.00	0.00	0.00
Education Fund	10 R 9601 0000 00 000 000000	TIF SURPLUS DONATION	0.00	0.00		0.00	0.00	0.00
10 - -----	Education Fund	TIF SURPLUS DONATION	37,809,332.67	1,282,264.99	-642.20	9,229,296.06	28,580,678.81	
Activity Fund	11 R 1799 0000 00 000 000000	ACTIVITY FUND ACCOUNT	0.00	0.00		0.00	0.00	0.00
Activity Fund	11 R 1799 0000 01 000 900000	COADY SCHOLARSHIP	1,000.00	15.79	0.00	935.23	64.77	43 6.48
Activity Fund	11 R 1799 0000 30 300 910001	SPORTS - ATHLETIC HALL OF FAME	0.00	0.00		0.00	0.00	0.00
Activity Fund	11 R 1799 0000 30 300 910002	SPORTS - ATHLETIC POP	5,500.00	68.83	0.00	-2,167.53	7,667.53	139.41
Activity Fund	11 R 1799 0000 30 300 910003	SPORTS - ATHLETIC TRAINING	0.00	0.00	0.00	-300.00	300.00	0.00
Activity Fund	11 R 1799 0000 30 300 910004	SPORTS - BASEBALL	500.00	0.00	0.00	-2,090.00	2,590.00	518.00
Activity Fund	11 R 1799 0000 30 300 910005	SPORTS - BOYS BASKETBALL	2,712.00	107.00	0.00	-7,771.00	10,483.00	386.54
Activity Fund	11 R 1799 0000 30 300 910006	SPORTS - BOYS BOWLING	400.00	0.00	0.00	-100.00	500.00	125.00
Activity Fund	11 R 1799 0000 30 300 910007	SPORTS - BOYS GOLF	400.00	0.00		400.00	0.00	0.00
Activity Fund	11 R 1799 0000 30 300 910008	SPORTS - BOYS SOCCER	6,761.61	5,510.00	0.00	-9,288.79	16,050.40	237.38
Activity Fund	11 R 1799 0000 30 300 910009	SPORTS - BOYS TENNIS	0.00	2,459.00	0.00	-2,459.00	2,459.00	0.00
Activity Fund	11 R 1799 0000 30 300 910010	SPORTS - BOYS TRACK	1,981.00	1,294.85	0.00	-217.67	2,198.67	110.99
Activity Fund	11 R 1799 0000 30 300 910011	SPORTS - BOYS VOLLEYBALL	400.00	0.00		400.00	0.00	0.00
Activity Fund	11 R 1799 0000 30 300 910012	SPORTS - CHEERLEADERS	19,796.53	0.00	0.00	-11,381.47	31,178.00	157.49
Activity Fund	11 R 1799 0000 30 300 910013	SPORTS - CROSS COUNTY CO ED	4,089.75	0.00	0.00	-2,985.25	7,075.00	172.99
Activity Fund	11 R 1799 0000 30 300 910014	SPORTS - FOOTBALL	23,222.50	4,684.00	0.00	-52,256.50	75,479.00	325.03

Revenue Report

Fiscal Year: 2021-2022
Month: March

COUNTY OF GRUNDY SCHOOL DIST 111

Fund Description	Account Number	Account Description	Revised Budget	Monthly Activity	Pending Activity	Available Funds	Year to Date Activity	Percent of Budget Used
Activity Fund	11 R 1799 0000 30 300 910015	SPORTS - FOOTBALL JERSEYS	0.00	0.00		0.00	0.00	0.00
Activity Fund	11 R 1799 0000 30 300 910016	SPORTS - GIRLS BASKETBALL	270.00	107.00	0.00	-9,715.00	9,985.00	3,698.15
Activity Fund	11 R 1799 0000 30 300 910017	SPORTS - GIRLS BOWLING	0.00	0.00	0.00	-1,969.00	1,969.00	0.00
Activity Fund	11 R 1799 0000 30 300 910018	SPORTS - GIRLS GOLF	400.00	0.00		400.00	0.00	0.00
Activity Fund	11 R 1799 0000 30 300 910019	SPORTS - GIRLS SOCCER	3,866.61	0.00		3,866.61	0.00	0.00
Activity Fund	11 R 1799 0000 30 300 910020	SPORTS - GIRLS TENNIS	915.00	0.00	0.00	890.00	25.00	2.73
Activity Fund	11 R 1799 0000 30 300 910021	SPORTS - GIRLS TRACK	4,352.00	0.00	0.00	4,106.91	245.09	5.63
Activity Fund	11 R 1799 0000 30 300 910022	SPORTS - GIRLS VOLLEYBALL	5,770.00	0.00	0.00	-4,414.00	10,184.00	176.50
Activity Fund	11 R 1799 0000 30 300 910023	SPORTS - LACROSSE	100.00	456.74	0.00	-356.74	456.74	456.74
Activity Fund	11 R 1799 0000 30 300 910024	SPORTS - OUTDOOR ED TRIP	0.00	0.00		0.00	0.00	0.00
Activity Fund	11 R 1799 0000 30 300 910025	SPORTS - POMS	12,180.50	0.00	0.00	-20,629.44	33,234.74	272.85
Activity Fund	11 R 1799 0000 30 300 910026	SPORTS - SOFTBALL	500.00	2,199.00	0.00	-1,699.00	2,199.00	44 439.80
Activity Fund	11 R 1799 0000 30 300 910027	SPORTS - SWIMMING B&G	300.00	0.00		300.00	0.00	0.00
Activity Fund	11 R 1799 0000 30 300 910028	SPORTS - WRESTLING	400.00	0.00	0.00	-5,885.00	6,285.00	1,571.25
Activity Fund	11 R 1799 0000 30 300 910029	SUMMER CAMPS - BAND CAMP	724.00	0.00	0.00	-17,807.00	18,531.00	2,559.53
Activity Fund	11 R 1799 0000 30 300 910030	SUMMER CAMPS - BASEBALL	0.00	0.00		0.00	0.00	0.00
Activity Fund	11 R 1799 0000 30 300 910031	SUMMER CAMPS - BOYS BASKETBALL	11,080.00	0.00	0.00	6,170.00	4,910.00	44.31
Activity Fund	11 R 1799 0000 30 300 910032	SUMMER CAMPS - BOYS VOLLEYBALL	0.00	0.00		0.00	0.00	0.00
Activity Fund	11 R 1799 0000 30 300 910033	SUMMER CAMPS - CHEERLEADING	250.00	0.00	0.00	-1,350.00	1,600.00	640.00
Activity Fund	11 R 1799 0000 30 300 910034	SUMMER CAMPS - CROSS COUNTRY	0.00	0.00	0.00	-4,200.00	4,200.00	0.00
Activity Fund	11 R 1799 0000 30 300 910035	SUMMER CAMPS - FOOTBALL	11,100.00	0.00	0.00	-1,925.00	13,025.00	117.34
Activity Fund	11 R 1799 0000 30 300 910036	SUMMER CAMPS - GIRLS BASKETBALL	2,850.00	0.00	0.00	425.00	2,425.00	85.09
Activity Fund	11 R 1799 0000 30 300 910037	SUMMER CAMPS - GIRLS VOLLEYBALL	3,750.00	0.00	0.00	-3,390.00	7,140.00	190.40
Activity Fund	11 R 1799 0000 30 300 910038	SUMMER CAMPS - POMS	500.00	0.00	0.00	-2,661.00	3,161.00	632.20
Activity Fund	11 R 1799 0000 30 300 910039	SUMMER CAMPS - SOCCER	720.00	0.00	0.00	-280.00	1,000.00	138.89

Revenue Report

Fiscal Year: 2021-2022
Month: March

COUNTY OF GRUNDY SCHOOL DIST 111

Fund Description	Account Number	Account Description	Revised Budget	Monthly Activity	Pending Activity	Available Funds	Year to Date Activity	Percent of Budget Used
Activity Fund	11 R 1799 0000 30 300 910040	SUMMER CAMPS - CONDITIONING	1,440.00	0.00	0.00	-250.00	1,690.00	117.36
Activity Fund	11 R 1799 0000 30 300 910041	SUMMER CAMPS - TENNIS CO-ED	525.00	0.00	0.00	-3,375.00	3,900.00	742.86
Activity Fund	11 R 1799 0000 30 300 910042	SUMMER CAMPS - WOMENS FITNESS	0.00	0.00		0.00	0.00	0.00
Activity Fund	11 R 1799 0000 70 300 900001	ACTIVITIES - POP	822.51	48.80	0.00	-10,730.38	11,552.89	1,404.59
Activity Fund	11 R 1799 0000 70 300 900002	ACTIVITIES - ART CLUB	0.00	0.00		0.00	0.00	0.00
Activity Fund	11 R 1799 0000 70 300 900003	ACTIVITIES - ATHLETIC LEADERSHIP	0.00	0.00		0.00	0.00	0.00
Activity Fund	11 R 1799 0000 70 300 900004	ACTIVITIES - BAND	0.00	0.00	0.00	-90.00	90.00	0.00
Activity Fund	11 R 1799 0000 70 300 900005	ACTIVITIES - CHESS	0.00	338.00	0.00	-338.00	338.00	0.00
Activity Fund	11 R 1799 0000 70 300 900006	ACTIVITIES - CHOIR PROJECTS	0.00	0.00		0.00	0.00	0.00
Activity Fund	11 R 1799 0000 70 300 900007	ACTIVITIES - CHORUS	2,813.78	0.00		2,813.78	0.00	0.00
Activity Fund	11 R 1799 0000 70 300 900008	ACTIVITIES - CLASS OF 2019	0.00	0.00		0.00	0.00	45
Activity Fund	11 R 1799 0000 70 300 900009	ACTIVITIES - CLASS OF 2020	0.00	0.00		0.00	0.00	0.00
Activity Fund	11 R 1799 0000 70 300 900010	ACTIVITIES - CLASS OF 2021	40.11	0.00		40.11	0.00	0.00
Activity Fund	11 R 1799 0000 70 300 900011	ACTIVITIES - CLASS OF 2022	180.11	11.48	0.00	-5,975.47	6,155.58	3,417.68
Activity Fund	11 R 1799 0000 70 300 900012	ACTIVITIES - CLASS OF 2023	0.00	11.48	0.00	-4,758.57	4,758.57	0.00
Activity Fund	11 R 1799 0000 70 300 900013	ACTIVITIES - CLASS OF 2024	0.00	4,985.00	0.00	-4,985.00	4,985.00	0.00
Activity Fund	11 R 1799 0000 70 300 900014	ACTIVITIES - COMMUNITY GARDEN	0.00	0.00		0.00	0.00	0.00
Activity Fund	11 R 1799 0000 70 300 900015	ACTIVITIES - CULINARY ARTS	0.00	0.00		0.00	0.00	0.00
Activity Fund	11 R 1799 0000 70 300 900016	ACTIVITIES - DEBATE CLUB	0.00	0.00		0.00	0.00	0.00
Activity Fund	11 R 1799 0000 70 300 900017	ACTIVITIES - DREAM	0.00	0.00		0.00	0.00	0.00
Activity Fund	11 R 1799 0000 70 300 900018	ACTIVITIES - FASHION MERCHANDISING	0.00	0.00		0.00	0.00	0.00
Activity Fund	11 R 1799 0000 70 300 900019	ACTIVITIES - FCCLA	0.00	0.00	0.00	-60.00	60.00	0.00
Activity Fund	11 R 1799 0000 70 300 900020	ACTIVITIES - FFA	172.50	1,916.00	0.00	-3,609.50	3,782.00	2,192.46
Activity Fund	11 R 1799 0000 70 300 900021	ACTIVITIES - FRENCH NHS	0.00	0.00		0.00	0.00	0.00

Revenue Report

Fiscal Year: 2021-2022
Month: March

COUNTY OF GRUNDY SCHOOL DIST 111

Fund Description	Account Number	Account Description	Revised Budget	Monthly Activity	Pending Activity	Available Funds	Year to Date Activity	Percent of Budget Used
Activity Fund	11 R 1799 0000 70 300 900022	ACTIVITIES - FUTURE BUSINESS LEADERS	0.00	0.00		0.00	0.00	0.00
Activity Fund	11 R 1799 0000 70 300 900023	ACTIVITIES - I.O.T.A.	500.00	0.00		500.00	0.00	0.00
Activity Fund	11 R 1799 0000 70 300 900024	ACTIVITIES - INDIAN CLIMBING CLUB	189.00	0.00		189.00	0.00	0.00
Activity Fund	11 R 1799 0000 70 300 900025	ACTIVITIES - INDIAN NATION	0.00	0.00		0.00	0.00	0.00
Activity Fund	11 R 1799 0000 70 300 900026	ACTIVITIES - INT'L CLUB	0.00	0.00	0.00	-3,180.00	3,180.00	0.00
Activity Fund	11 R 1799 0000 70 300 900027	ACTIVITIES - INT'L THESPIANS	420.00	0.00	0.00	-8,394.06	8,814.06	2,098.59
Activity Fund	11 R 1799 0000 70 300 900028	ACTIVITIES - INTERACT	0.00	0.00		0.00	0.00	0.00
Activity Fund	11 R 1799 0000 70 300 900029	ACTIVITIES - INVESTMENT CLUB	0.00	0.00		0.00	0.00	0.00
Activity Fund	11 R 1799 0000 70 300 900030	ACTIVITIES - JUDO	0.00	0.00	0.00	-400.00	400.00	0.00
Activity Fund	11 R 1799 0000 70 300 900031	ACTIVITIES - KALEIDOSOPE	0.00	0.00		0.00	0.00	0.00
Activity Fund	11 R 1799 0000 70 300 900032	ACTIVITIES - MAC	4,283.00	1,313.73	0.00	-7,559.73	11,842.73	46 276.51
Activity Fund	11 R 1799 0000 70 300 900033	ACTIVITIES - MATH TEAM	0.00	240.00	0.00	-240.00	240.00	0.00
Activity Fund	11 R 1799 0000 70 300 900034	ACTIVITIES - MCHS BOOK CLUB	0.00	0.00		0.00	0.00	0.00
Activity Fund	11 R 1799 0000 70 300 900035	ACTIVITIES - MEMORIAL GARDEN	0.00	0.00		0.00	0.00	0.00
Activity Fund	11 R 1799 0000 70 300 900036	ACTIVITIES - MUSICAL	1,675.23	660.00	0.00	1,015.23	660.00	39.40
Activity Fund	11 R 1799 0000 70 300 900037	ACTIVITIES - NEEDY FAMILIES	0.00	0.00	0.00	-8,609.82	8,609.82	0.00
Activity Fund	11 R 1799 0000 70 300 900038	ACTIVITIES - NHS	4,925.00	0.00	0.00	-1,326.59	6,251.59	126.94
Activity Fund	11 R 1799 0000 70 300 900039	ACTIVITIES - ORCHESIS	0.00	664.48	0.00	-1,752.29	1,752.29	0.00
Activity Fund	11 R 1799 0000 70 300 900040	ACTIVITIES - PAC RESTORATION	1,607.80	2,012.00	0.00	-404.20	2,012.00	125.14
Activity Fund	11 R 1799 0000 70 300 900041	ACTIVITIES - PERCUSSION	3,000.00	2,864.40	0.00	-17,378.40	20,378.40	679.28
Activity Fund	11 R 1799 0000 70 300 900042	ACTIVITIES - POKEMON CLUB	0.00	0.00		0.00	0.00	0.00
Activity Fund	11 R 1799 0000 70 300 900043	ACTIVITIES - NEWSPAPER	0.00	0.00	0.00	-442.00	442.00	0.00
Activity Fund	11 R 1799 0000 70 300 900044	ACTIVITIES - SADD	0.00	0.00		0.00	0.00	0.00
Activity Fund	11 R 1799 0000 70 300 900045	ACTIVITIES - SCHOLASTIC BOWL	0.00	200.00	0.00	-200.00	200.00	0.00
Activity Fund	11 R 1799 0000 70 300 900046	ACTIVITIES - SPANISH NHS	485.00	0.00	0.00	-855.00	1,340.00	276.29

Revenue Report

Fiscal Year: 2021-2022
Month: March

COUNTY OF GRUNDY SCHOOL DIST 111

Fund Description	Account Number	Account Description	Revised Budget	Monthly Activity	Pending Activity	Available Funds	Year to Date Activity	Percent of Budget Used
Activity Fund	11 R 1799 0000 70 300 900047	ACTIVITIES - SPEECH	0.00	0.00	0.00	-42,960.00	42,960.00	0.00
Activity Fund	11 R 1799 0000 70 300 900048	ACTIVITIES - STUDENT COUNCIL	430.00	-35.00	0.00	-6,585.00	7,015.00	1,631.40
Activity Fund	11 R 1799 0000 70 300 900049	ACTIVITIES - TSA	1,095.65	0.00	0.00	-2,849.35	3,945.00	360.06
Activity Fund	11 R 1799 0000 70 300 900050	ACTIVITIES - UNDERWATER ROBOTIC	0.00	2,341.76	0.00	-3,757.10	3,757.10	0.00
Activity Fund	11 R 1799 0000 70 300 900051	ACTIVITIES - WINTERGUARD	755.00	9,731.83	0.00	-20,475.69	21,230.69	2,812.01
Activity Fund	11 R 1799 0000 70 300 900052	ACTIVITIES - WYSE	0.00	0.00		0.00	0.00	0.00
Activity Fund	11 R 1799 0000 70 300 900053	ACTIVITIES - YEARBOOK	11,247.30	191.26	0.00	3,611.48	7,635.82	67.89
Activity Fund	11 R 1799 0000 70 300 900054	COADY SCHOLARSHIP ENDOWMENT	1,000.00	0.00		1,000.00	0.00	0.00
Activity Fund	11 R 1799 0000 70 300 900055	CYBRARY	0.00	0.00		0.00	0.00	0.00
Activity Fund	11 R 1799 0000 70 300 900056	FACULTY POP	240.72	68.83	0.00	-104.52	345.24	143.42
Activity Fund	11 R 1799 0000 70 300 900057	PROJECT INDIAN	0.00	0.00		0.00	0.00	0.00
Activity Fund	11 R 1799 0000 70 300 900058	PROM	10,290.00	105,415.00	0.00	-95,125.00	105,415.00	47 1,024.44
Activity Fund	11 R 1799 0000 70 300 900059	SCHOLARSHIP	24,000.00	2,000.00	0.00	19,000.00	5,000.00	20.83
Activity Fund	11 R 1799 0000 70 300 900060	TV PRODUCTION	0.00	0.00		0.00	0.00	0.00
Activity Fund	11 R 1799 0000 70 300 900061	ASL - AMERICAN SIGN LANGUAGE CLUB	162.79	0.00	0.00	-423.21	586.00	359.97
Activity Fund	11 R 1799 0000 70 300 900062	GREEN HOUSE	908.00	0.00	0.00	238.00	670.00	73.79
Activity Fund	11 R 1799 0000 70 300 900063	CLASS OF 2025	0.00	4,985.00	0.00	-4,985.00	4,985.00	0.00
11 - ---- - - - - - - - -	Activity Fund	CLASS OF 2025	200,000.00	156,866.26	0.00	-383,175.92	583,600.72	
Operations & Maint Fund	20 R 1110 0000 00 000 000000	PRIOR YEAR TAXES	0.00	0.00		0.00	0.00	0.00
Operations & Maint Fund	20 R 1111 0000 00 000 000000	GRUNDY CO TAXES	1,494,265.00	0.00	0.00	34,984.50	1,459,280.50	97.66
Operations & Maint Fund	20 R 1112 0000 00 000 000000	KENDALL CO TAXES	211,282.83	0.00	0.00	2,484.29	208,798.54	98.82
Operations & Maint Fund	20 R 1113 0000 00 000 000000	WILL CO TAXES	1,177,269.39	0.00	0.00	2,381.83	1,174,887.56	99.80
Operations & Maint Fund	20 R 1114 0000 00 000 000000	GRUNDY CO EDPA SURPLUS	0.00	0.00		0.00	0.00	0.00
Operations & Maint Fund	20 R 1122 0000 00 000 000000	KENDALL CO - EARLY DISTR	236,369.42	0.00		236,369.42	0.00	0.00
Operations & Maint Fund	20 R 1123 0000 00 000 000000	WILL CO - EARLY DISTR	1,326,302.00	0.00		1,326,302.00	0.00	0.00
Operations & Maint Fund	20 R 1210 0000 00 000 000000	MOBILE HOME TAX	0.00	0.00		0.00	0.00	0.00
Operations & Maint Fund	20 R 1211 0000 00 000 000000	GRUNDY CO TORT	0.00	0.00		0.00	0.00	0.00

Revenue Report

Fiscal Year: 2021-2022
Month: March

COUNTY OF GRUNDY SCHOOL DIST 111

Fund Description	Account Number	Account Description	Revised Budget	Monthly Activity	Pending Activity	Available Funds	Year to Date Activity	Percent of Budget Used
Operations & Maint Fund	20 R 1212 0000 00 000 000000	KENDALL CO TORT	0.00	0.00		0.00	0.00	0.00
Operations & Maint Fund	20 R 1213 0000 00 000 000000	WILL CO TORT	0.00	0.00		0.00	0.00	0.00
Operations & Maint Fund	20 R 1222 0000 00 000 000000	KENDALL CO TORT-EARLY DIST	0.00	0.00		0.00	0.00	0.00
Operations & Maint Fund	20 R 1223 0000 00 000 000000	WILL CO TORT-EARLY DISTR	0.00	0.00		0.00	0.00	0.00
Operations & Maint Fund	20 R 1230 0000 00 000 000000	CPPRT	250,000.00	74,194.36	0.00	-27,982.37	277,982.37	111.19
Operations & Maint Fund	20 R 1290 0000 00 000 000000	ESCROW PMTS/LIEU OF TAXES	0.00	0.00		0.00	0.00	0.00
Operations & Maint Fund	20 R 1311 0000 00 000 000000	GRUNDY CO LEASE	0.00	0.00		0.00	0.00	0.00
Operations & Maint Fund	20 R 1312 0000 00 000 000000	KENDALL CO LEASE	0.00	0.00		0.00	0.00	0.00
Operations & Maint Fund	20 R 1313 0000 00 000 000000	WILL CO LEASE	0.00	0.00		0.00	0.00	0.00
Operations & Maint Fund	20 R 1322 0000 00 000 000000	KENDALL CO LEASE-EARLY DISTR	0.00	0.00		0.00	0.00	0.00
Operations & Maint Fund	20 R 1323 0000 00 000 000000	WILL CO LEASE-EARLY DISTR	0.00	0.00		0.00	0.00	0.00
Operations & Maint Fund	20 R 1510 0000 00 000 000000	CHECKING INTEREST	0.00	0.00		0.00	0.00	48
Operations & Maint Fund	20 R 1511 0000 00 000 000000	INVESTMENT INTEREST	3,000.00	533.11	0.00	1,411.54	1,588.46	52.95
Operations & Maint Fund	20 R 1910 0000 00 000 000000	CLASSROOM RENTAL	0.00	0.00		0.00	0.00	0.00
Operations & Maint Fund	20 R 1911 0000 00 000 000000	BUILDING RENTAL	0.00	0.00	0.00	-6,375.86	6,375.86	0.00
Operations & Maint Fund	20 R 1912 0000 00 000 000000	FARM LEASE PAYMENTS	62,000.00	0.00	0.00	9,521.89	52,478.11	84.64
Operations & Maint Fund	20 R 1950 0000 00 000 000000	REFUND OF PRIOR YR EXPENSES	0.00	0.00		0.00	0.00	0.00
Operations & Maint Fund	20 R 1991 0000 00 000 000000	SP ED HOUSING ASSESMENT	0.00	0.00		0.00	0.00	0.00
Operations & Maint Fund	20 R 1996 0000 00 000 000000	SALE OF CROPS	0.00	0.00		0.00	0.00	0.00
Operations & Maint Fund	20 R 1997 0000 00 000 000000	INSURANCE	0.00	0.00	0.00	-350,000.00	350,000.00	0.00
Operations & Maint Fund	20 R 1998 0000 00 000 000000	SALE OF EQUIPMENT	0.00	0.00		0.00	0.00	0.00
Operations & Maint Fund	20 R 1999 0000 00 000 000000	OTHER-LOCAL SOURCES	20,000.00	0.00	0.00	4,399.56	15,600.44	78.00
Operations & Maint Fund	20 R 1999 2220 00 000 000000	DIST 111 GROUP MEDICAL REVENUE	205,180.00	15,568.39	0.00	50,365.28	154,814.72	75.45
Operations & Maint Fund	20 R 1999 2230 00 000 000000	DIST 111 GROUP DENTAL REVENUE	11,400.00	811.44	0.00	3,423.84	7,976.16	69.97
Operations & Maint Fund	20 R 2901 0000 00 000 000000	GRUNDY CO TIF EXT	0.00	0.00		0.00	0.00	0.00
Operations & Maint Fund	20 R 3925 0000 00 000 000000	SCHOOL MAINTENANCE PROJECTS	0.00	0.00	0.00	-50,000.00	50,000.00	0.00

Revenue Report

Fiscal Year: 2021-2022
Month: March

COUNTY OF GRUNDY SCHOOL DIST 111

Fund Description	Account Number	Account Description	Revised Budget	Monthly Activity	Pending Activity	Available Funds	Year to Date Activity	Percent of Budget Used
Operations & Maint Fund	20 R 3999 0000 00 000 000000	OTH GRANTS-IN-AID/STATE SOURCE	0.00	0.00		0.00	0.00	0.00
Operations & Maint Fund	20 R 4590 0000 00 000 000000	COPS GRANT - MINOOKA	0.00	0.00		0.00	0.00	0.00
Operations & Maint Fund	20 R 4998 0000 00 000 499801	ESSER 1	0.00	0.00	0.00	0.00	0.00	0.00
Operations & Maint Fund	20 R 4998 0000 00 000 499802	ESSER II	281,358.00	0.00	0.00	281,358.00	0.00	0.00
Operations & Maint Fund	20 R 4998 0000 00 000 499803	ESSER III	830,062.00	0.00	0.00	830,062.00	0.00	0.00
Operations & Maint Fund	20 R 7110 0000 00 000 000000	PERM TRANS FROM W/C-ABATEMENT	0.00	0.00		0.00	0.00	0.00
Operations & Maint Fund	20 R 7130 0000 00 000 000000	PERM TRANS AMONG FUNDS	0.00	0.00		0.00	0.00	0.00
Operations & Maint Fund	20 R 7900 0000 00 000 000000	DEBT PROCEEDS	0.00	0.00		0.00	0.00	0.00
Operations & Maint Fund	20 R 8410 0000 00 000 000000	TAXES PLEDGED/PRINC-CAP LEASE	0.00	0.00		0.00	0.00	0.00
Operations & Maint Fund	20 R 9601 0000 00 000 000000	TIF SURPLUS DONATION	0.00	0.00		0.00	0.00	0.00
20 - -----	Operations & Maint Fund	TIF SURPLUS DONATION	6,108,488.64	91,107.30	0.00	2,348,705.92	3,759,782.72	
Debt Service Fund or Fund Group	30 R 1110 0000 00 000 000000	PRIOR YEAR TAXES	0.00	0.00		0.00	0.00	49 0.00
Debt Service Fund or Fund Group	30 R 1111 0000 00 000 000000	GRUNDY CO TAXES	3,115,842.00	0.00	0.00	30,226.11	3,085,615.89	99.03
Debt Service Fund or Fund Group	30 R 1112 0000 00 000 000000	KENDALL CO TAXES	460,656.32	0.00	0.00	9,968.85	450,687.47	97.84
Debt Service Fund or Fund Group	30 R 1113 0000 00 000 000000	WILL CO TAXES	2,428,000.44	0.00	0.00	4,912.35	2,423,088.09	99.80
Debt Service Fund or Fund Group	30 R 1114 0000 00 000 000000	GRUNDY CO EPDA SURPLUS	0.00	0.00		0.00	0.00	0.00
Debt Service Fund or Fund Group	30 R 1122 0000 00 000 000000	KENDALL CO - EARLY DISTR	490,967.00	0.00		490,967.00	0.00	0.00
Debt Service Fund or Fund Group	30 R 1123 0000 00 000 000000	WILL CO - EARLY DISTR	2,354,542.00	0.00		2,354,542.00	0.00	0.00
Debt Service Fund or Fund Group	30 R 1210 0000 00 000 000000	MOBILE HOME TAX	0.00	0.00		0.00	0.00	0.00
Debt Service Fund or Fund Group	30 R 1290 0000 00 000 000000	PAYMENT IN LIEU OF TAXES BONDS	0.00	0.00		0.00	0.00	0.00
Debt Service Fund or Fund Group	30 R 1301 0000 00 000 000000	GRUNDY CO LEASE	0.00	0.00		0.00	0.00	0.00
Debt Service Fund or Fund Group	30 R 1302 0000 00 000 000000	KENDALL CO LEASE	0.00	0.00		0.00	0.00	0.00
Debt Service Fund or Fund Group	30 R 1303 0000 00 000 000000	WILL CO LEASE	0.00	0.00		0.00	0.00	0.00

Revenue Report

Fiscal Year: 2021-2022
Month: March

COUNTY OF GRUNDY SCHOOL DIST 111

Fund Description	Account Number	Account Description	Revised Budget	Monthly Activity	Pending Activity	Available Funds	Year to Date Activity	Percent of Budget Used
Debt Service Fund or Fund Group	30 R 1323 0000 00 000 000000	WILL CO LEASE-EARLY DIST	0.00	0.00		0.00	0.00	0.00
Debt Service Fund or Fund Group	30 R 1510 0000 00 000 000000	CHECKING INTEREST	0.00	0.00		0.00	0.00	0.00
Debt Service Fund or Fund Group	30 R 1511 0000 00 000 000000	INVESTMENT INTEREST	4,000.00	449.22	0.00	2,311.51	1,688.49	42.21
Debt Service Fund or Fund Group	30 R 1512 0000 00 000 000000	BOND INTEREST	0.00	0.00		0.00	0.00	0.00
Debt Service Fund or Fund Group	30 R 1999 0000 00 000 000000	OTHER-LOCAL SOURCES	0.00	0.00	0.00	-5,106.71	5,106.71	0.00
Debt Service Fund or Fund Group	30 R 2901 0000 00 000 000000	GRUNDY CO TIF EXT	0.00	0.00		0.00	0.00	0.00
Debt Service Fund or Fund Group	30 R 7210 0000 00 000 000000	PRINCIPAL ON BONDS SOLD	0.00	0.00		0.00	0.00	0.00
Debt Service Fund or Fund Group	30 R 7220 0000 00 000 000000	PREMIUM ON BONDS SOLD	0.00	0.00		0.00	0.00	0.00
Debt Service Fund or Fund Group	30 R 7230 0000 00 000 000000	INTEREST ON BONDS SOLD	0.00	0.00		0.00	0.00	0.00
Debt Service Fund or Fund Group	30 R 7400 0000 00 000 000000	TRANS FROM OTHER FUNDS	0.00	0.00		0.00	0.00	50 0.00
Debt Service Fund or Fund Group	30 R 7401 0000 00 000 000000	TRANS FROM OBM LEASE	0.00	0.00		0.00	0.00	0.00
Debt Service Fund or Fund Group	30 R 7500 0000 00 000 000000	TRANS FROM OTHER FUNDS	0.00	0.00		0.00	0.00	0.00
Debt Service Fund or Fund Group	30 R 8990 0000 00 000 000000	DISCOUNT ON BONDS SOLD	0.00	0.00		0.00	0.00	0.00
Debt Service Fund or Fund Group	30 R 8991 0000 00 000 000000	REFUNDED PRINCIPAL	0.00	0.00		0.00	0.00	0.00
Debt Service Fund or Fund Group	30 R 8992 0000 00 000 000000	REFUNDED INTEREST	0.00	0.00		0.00	0.00	0.00
Debt Service Fund or Fund Group	30 R 9601 0000 00 000 000000	TIF SURPLUS DONATION	0.00	0.00		0.00	0.00	0.00
30 - -----	Debt Service Fund or Fund	TIF SURPLUS DONATION	8,854,007.76	449.22	0.00	2,887,821.11	5,966,186.65	
Transportation Fund	40 R 1110 0000 00 000 000000	PRIOR YEAR TAXES	0.00	0.00		0.00	0.00	0.00
Transportation Fund	40 R 1111 0000 00 000 000000	GRUNDY CO TAXES	710,074.53	0.00	0.00	9,619.89	700,454.64	98.65
Transportation Fund	40 R 1112 0000 00 000 000000	KENDALL CO TAXES	101,416.59	0.00	0.00	12,038.30	89,378.29	88.13
Transportation Fund	40 R 1113 0000 00 000 000000	WILL CO TAXES	565,090.02	0.00	0.00	1,143.99	563,946.03	99.80
Transportation Fund	40 R 1114 0000 00 000 000000	GRUNDY CO EPDA SURPLUS	0.00	0.00		0.00	0.00	0.00
Transportation Fund	40 R 1122 0000 00 000 000000	KENDALL CO-EARLY DISTR	113,457.45	0.00	0.00	102,612.45	10,845.00	9.56

Revenue Report

Fiscal Year: 2021-2022
Month: March

COUNTY OF GRUNDY SCHOOL DIST 111

Fund Description	Account Number	Account Description	Revised Budget	Monthly Activity	Pending Activity	Available Funds	Year to Date Activity	Percent of Budget Used
Transportation Fund	40 R 1123 0000 00 000 000000	WILL CO-EARLY DISTR	547,904.20	0.00		547,904.20	0.00	0.00
Transportation Fund	40 R 1210 0000 00 000 000000	MOBILE HOME TAX	0.00	0.00		0.00	0.00	0.00
Transportation Fund	40 R 1211 0000 00 000 000000	GRUNDY CO TORT	0.00	0.00		0.00	0.00	0.00
Transportation Fund	40 R 1212 0000 00 000 000000	KENDALL CO TORT	0.00	0.00		0.00	0.00	0.00
Transportation Fund	40 R 1213 0000 00 000 000000	WILL CO TORT	0.00	0.00		0.00	0.00	0.00
Transportation Fund	40 R 1223 0000 00 000 000000	WILL CO TORT-EARLY DISTR	0.00	0.00		0.00	0.00	0.00
Transportation Fund	40 R 1230 0000 00 000 000000	CPPRT	0.00	0.00		0.00	0.00	0.00
Transportation Fund	40 R 1290 0000 00 000 000000	PAYMENT IN LIEU OF TAXES TRANS	0.00	0.00		0.00	0.00	0.00
Transportation Fund	40 R 1442 0000 00 000 000000	SP ED TRAN OTHER DISTRICT	0.00	0.00		0.00	0.00	0.00
Transportation Fund	40 R 1510 0000 00 000 000000	CHECKING INTEREST	0.00	0.00		0.00	0.00	0.00
Transportation Fund	40 R 1511 0000 00 000 000000	INVESTMENT INTEREST	1,500.00	169.35	0.00	711.32	788.68	52.58
Transportation Fund	40 R 1950 0000 00 000 000000	REFUND OF PRIOR YR EXPENSES	0.00	0.00		0.00	0.00	51 0.00
Transportation Fund	40 R 1998 0000 00 000 000000	SALE OF EQUIPMENT	5,000.00	0.00	0.00	2,200.00	2,800.00	56.00
Transportation Fund	40 R 1999 0000 00 000 000000	OTHER-LOCAL SOURCES	0.00	0.00		0.00	0.00	0.00
Transportation Fund	40 R 1999 2220 00 000 000000	DIST 111 GROUP MEDICAL REVENUE	97,813.00	11,220.93	0.00	-1,318.18	99,131.18	101.35
Transportation Fund	40 R 1999 2230 00 000 000000	DIST 111 GROUP DENTAL REVENUE	4,116.00	395.68	0.00	617.22	3,498.78	85.00
Transportation Fund	40 R 2901 0000 00 000 000000	GRUNDY CO TIF EXT	0.00	0.00		0.00	0.00	0.00
Transportation Fund	40 R 3500 0000 00 000 000000	TRANS - REGULAR REIMB	83,724.00	0.00	0.00	-37,001.08	120,725.08	144.19
Transportation Fund	40 R 3505 0000 00 000 000000	TRANS - VOCATIONAL REIMB	0.00	0.00		0.00	0.00	0.00
Transportation Fund	40 R 3510 0000 00 000 000000	TRANS-SPEC ED REIMB	762,603.00	0.00	0.00	61,139.16	701,463.84	91.98
Transportation Fund	40 R 3999 0000 00 000 000000	OTHER RESTRICTED REV STATE	0.00	0.00		0.00	0.00	0.00
Transportation Fund	40 R 4999 0000 00 000 000000	OTHER RESTRICTED REV FEDERAL	0.00	0.00		0.00	0.00	0.00
Transportation Fund	40 R 7130 0000 00 000 000000	PERM TRANS AMONG FUNDS	0.00	0.00		0.00	0.00	0.00
Transportation Fund	40 R 7140 0000 00 000 000000	INT TRANS FROM SITE/CONST	0.00	0.00		0.00	0.00	0.00
Transportation Fund	40 R 9601 0000 00 000 000000	TIF SURPLUS DONATION	0.00	0.00		0.00	0.00	0.00

Revenue Report

Fiscal Year: 2021-2022
Month: March

COUNTY OF GRUNDY SCHOOL DIST 111

Fund Description	Account Number	Account Description	Revised Budget	Monthly Activity	Pending Activity	Available Funds	Year to Date Activity	Percent of Budget Used
40 - -----	Transportation Fund	TIF SURPLUS DONATION	2,992,698.79	11,785.96	0.00	699,667.27	2,293,031.52	
I.M.R.F./Soc. Sec. Fund	50 R 1110 0000 00 000 000000	PRIOR YEAR TAXES	0.00	0.00		0.00	0.00	0.00
I.M.R.F./Soc. Sec. Fund	50 R 1111 0000 00 000 000000	GRUNDY CO IMRF	149,056.38	0.00	0.00	2,021.24	147,035.14	98.64
I.M.R.F./Soc. Sec. Fund	50 R 1112 0000 00 000 000000	KENDALL CO IMRF	31,940.37	0.00	0.00	10,158.51	21,781.86	68.20
I.M.R.F./Soc. Sec. Fund	50 R 1113 0000 00 000 000000	WILL CO IMRF	117,726.84	0.00	0.00	238.07	117,488.77	99.80
I.M.R.F./Soc. Sec. Fund	50 R 1114 0000 00 000 000000	GRUNDY CO IMRF EDPA SURPLUS	0.00	0.00		0.00	0.00	0.00
I.M.R.F./Soc. Sec. Fund	50 R 1122 0000 00 000 000000	KENDALL CO-EARLY DISTR	20,000.00	0.00		20,000.00	0.00	0.00
I.M.R.F./Soc. Sec. Fund	50 R 1123 0000 00 000 000000	WILL CO-EARLY DISTR	110,000.00	0.00		110,000.00	0.00	0.00
I.M.R.F./Soc. Sec. Fund	50 R 1210 0000 00 000 000000	MOBILE HOME TAX	0.00	0.00		0.00	0.00	0.00
I.M.R.F./Soc. Sec. Fund	50 R 1211 0000 00 000 000000	MOBILE HOME TAX IMRF	0.00	0.00		0.00	0.00	0.00
I.M.R.F./Soc. Sec. Fund	50 R 1212 0000 00 000 000000	MOBILE HOME TAX SOC SEC	0.00	0.00		0.00	0.00	0.00
I.M.R.F./Soc. Sec. Fund	50 R 1230 0000 00 000 000000	CPPRT	125,000.00	38,221.34	0.00	-17,334.86	142,334.86	113.87
I.M.R.F./Soc. Sec. Fund	50 R 1290 0000 00 000 000000	PAYMENT IN LIEU OF TAXES IMRF	0.00	0.00		0.00	0.00	52 0.00
I.M.R.F./Soc. Sec. Fund	50 R 1291 0000 00 000 000000	PAYMENT IN LIEU OF TAXES SOC SEC	0.00	0.00		0.00	0.00	0.00
I.M.R.F./Soc. Sec. Fund	50 R 1510 0000 00 000 000000	CHECKING INTEREST	0.00	0.00		0.00	0.00	0.00
I.M.R.F./Soc. Sec. Fund	50 R 1511 0000 00 000 000000	INVESTMENT INTEREST	1,700.00	269.99	0.00	765.59	934.41	54.97
I.M.R.F./Soc. Sec. Fund	50 R 1511 0000 00 000 000001	GRUNDY CO SS	185,388.39	0.00	0.00	2,513.00	182,875.39	98.64
I.M.R.F./Soc. Sec. Fund	50 R 1512 0000 00 000 000000	KENDALL CO SS	27,416.07	0.00	0.00	322.36	27,093.71	98.82
I.M.R.F./Soc. Sec. Fund	50 R 1513 0000 00 000 000000	WILL CO SS	145,981.44	0.00	0.00	295.39	145,686.05	99.80
I.M.R.F./Soc. Sec. Fund	50 R 1514 0000 00 000 000000	GRUNDY CO SS EDPA SURPLUS	0.00	0.00		0.00	0.00	0.00
I.M.R.F./Soc. Sec. Fund	50 R 1522 0000 00 000 000000	KENDALL CO SS-EARLY DISTR	25,000.00	0.00		25,000.00	0.00	0.00
I.M.R.F./Soc. Sec. Fund	50 R 1523 0000 00 000 000000	WILL CO SS-EARLY DISTR	135,000.00	0.00		135,000.00	0.00	0.00
I.M.R.F./Soc. Sec. Fund	50 R 1999 0000 00 000 000000	OTHER-LOCAL SOURCES	0.00	0.00		0.00	0.00	0.00
I.M.R.F./Soc. Sec. Fund	50 R 2901 0000 00 000 000000	GRUNDY CO IMRF TIF	0.00	0.00		0.00	0.00	0.00
I.M.R.F./Soc. Sec. Fund	50 R 2902 0000 00 000 000000	GRUNDY CO SS TIF	0.00	0.00		0.00	0.00	0.00
I.M.R.F./Soc. Sec. Fund	50 R 9601 0000 00 000 000000	TIF SURPLUS DONATION	0.00	0.00		0.00	0.00	0.00
50 - -----	I.M.R.F./Soc. Sec. Fund	TIF SURPLUS DONATION	1,074,209.49	38,491.33	0.00	288,979.30	785,230.19	

Revenue Report

Fiscal Year: 2021-2022
Month: March

COUNTY OF GRUNDY SCHOOL DIST 111

Fund Description	Account Number	Account Description	Revised Budget	Monthly Activity	Pending Activity	Available Funds	Year to Date Activity	Percent of Budget Used
Capital Projects Fund or Fund Group	60 R 1291 0000 00 000 000000	FACILITIES IMPACT FEES	170,000.00	9,757.96	0.00	112,094.03	57,905.97	34.06
Capital Projects Fund or Fund Group	60 R 1292 0000 00 000 000000	SCHOOL SITE FEES	122,000.00	4,329.72	0.00	99,948.39	22,051.61	18.08
Capital Projects Fund or Fund Group	60 R 1510 0000 00 000 000000	CHECKING INTEREST	0.00	0.00		0.00	0.00	0.00
Capital Projects Fund or Fund Group	60 R 1511 0000 00 000 000000	INVESTMENT INTEREST	4,600.00	199.05	0.00	3,296.64	1,303.36	28.33
Capital Projects Fund or Fund Group	60 R 1520 0000 00 000 000000	GAIN/LOSS ON INVESTMENTS	0.00	0.00		0.00	0.00	0.00
Capital Projects Fund or Fund Group	60 R 1930 0000 00 000 000000	IMPACT FEES	0.00	0.00	0.00	-14,344.20	14,344.20	0.00
Capital Projects Fund or Fund Group	60 R 1999 0000 00 000 000000	OTHER-LOCAL SOURCES	0.00	0.00		0.00	0.00	0.00
Capital Projects Fund or Fund Group	60 R 4590 0000 00 000 000000	COPS GRANT - CHANNAHON	0.00	0.00		0.00	0.00	0.00
Capital Projects Fund or Fund Group	60 R 7110 0000 00 000 000000	PERM TRANS FROM W/C-ABATEMENT	0.00	0.00		0.00	0.00	0.00
Capital Projects Fund or Fund Group	60 R 7210 0000 00 000 000000	PRINCIPAL ON BONDS SOLD	0.00	0.00		0.00	0.00	53 0.00
Capital Projects Fund or Fund Group	60 R 7800 0000 00 000 000000	TRANS FROM OTHER FUNDS	0.00	0.00		0.00	0.00	0.00
60 - -----	Capital Projects Fund or	TRANS FROM OTHER	296,600.00	14,286.73	0.00	200,994.86	95,605.14	
Working Cash Fund	70 R 1110 0000 00 000 000000	PRIOR YEAR TAXES	0.00	0.00		0.00	0.00	0.00
Working Cash Fund	70 R 1111 0000 00 000 000000	GRUNDY CO TAXES	295,864.47	0.00	0.00	4,008.36	291,856.11	98.65
Working Cash Fund	70 R 1112 0000 00 000 000000	KENDALL CO TAXES	42,256.17	0.00	0.00	496.46	41,759.71	98.83
Working Cash Fund	70 R 1113 0000 00 000 000000	WILL CO TAXES	235,453.68	0.00	0.00	476.18	234,977.50	99.80
Working Cash Fund	70 R 1114 0000 00 000 000000	GRUNDY CO EDPA SURPLUS	0.00	0.00		0.00	0.00	0.00
Working Cash Fund	70 R 1122 0000 00 000 000000	KENDALL CO-EARLY DISTR	47,273.67	0.00		47,273.67	0.00	0.00
Working Cash Fund	70 R 1123 0000 00 000 000000	WILL CO-EARLY DISTR	228,293.06	0.00		228,293.06	0.00	0.00
Working Cash Fund	70 R 1210 0000 00 000 000000	MOBILE HOME TAX	0.00	0.00		0.00	0.00	0.00
Working Cash Fund	70 R 1230 0000 00 000 000000	CPPRT	0.00	0.00	0.00	0.00	0.00	0.00
Working Cash Fund	70 R 1290 0000 00 000 000000	PAYMENT IN LIEU OF TAXES WORKING CASH	0.00	0.00		0.00	0.00	0.00
Working Cash Fund	70 R 1510 0000 00 000 000000	CHECKING INTEREST	0.00	0.00		0.00	0.00	0.00
Working Cash Fund	70 R 1511 0000 00 000 000000	INVESTMENT INTEREST	8,400.00	788.25	0.00	5,451.10	2,948.90	35.11
Working Cash Fund	70 R 1960 0000 00 000 000000	TIF SURPLUS DONATION	0.00	0.00		0.00	0.00	0.00

Revenue Report

Fiscal Year: 2021-2022
Month: March

COUNTY OF GRUNDY SCHOOL DIST 111

Fund Description	Account Number	Account Description	Revised Budget	Monthly Activity	Pending Activity	Available Funds	Year to Date Activity	Percent of Budget Used
Working Cash Fund	70 R 1999 0000 99 000 000000	OTHER-LOCAL SOURCES	0.00	0.00		0.00	0.00	0.00
Working Cash Fund	70 R 2901 0000 00 000 000000	GRUNDY CO TIF EXT	0.00	0.00		0.00	0.00	0.00
Working Cash Fund	70 R 7210 0000 00 000 000000	PRIN ON BONDS SOLD	0.00	0.00		0.00	0.00	0.00
Working Cash Fund	70 R 7220 0000 00 000 000000	PREMIUM ON BONDS SOLD	0.00	0.00		0.00	0.00	0.00
Working Cash Fund	70 R 8110 0000 00 000 000000	ABATEMENT OF W/C FUND	0.00	0.00		0.00	0.00	0.00
70 - -----	Working Cash Fund	ABATEMENT OF W/C FUND	857,541.05	788.25	0.00	285,998.83	571,542.22	
Tort Immunity and Judgment Fund	80 R 1110 0000 00 000 000000	PRIOR YEAR TAXES	0.00	0.00		0.00	0.00	0.00
Tort Immunity and Judgment Fund	80 R 1111 0000 00 000 000000	GRUNDY CO TORT	427,109.76	0.00	0.00	5,792.90	421,316.86	98.64
Tort Immunity and Judgment Fund	80 R 1112 0000 00 000 000000	KENDALL CO TORT	63,148.14	0.00	0.00	742.44	62,405.70	98.82
Tort Immunity and Judgment Fund	80 R 1113 0000 00 000 000000	WILL CO TORT	337,170.24	0.00	0.00	682.45	336,487.79	99.80
Tort Immunity and Judgment Fund	80 R 1114 0000 00 000 000000	GRUNDY CO TORT EDPA SURPLUS	0.00	0.00		0.00	0.00	0.00
Tort Immunity and Judgment Fund	80 R 1122 0000 00 000 000000	KENDALL CO TORT-EARLY DISTR	70,645.68	0.00		70,645.68	0.00	0.00
Tort Immunity and Judgment Fund	80 R 1123 0000 00 000 000000	WILL CO TORT-EARLY DISTR	326,916.03	0.00		326,916.03	0.00	0.00
Tort Immunity and Judgment Fund	80 R 1210 0000 00 000 000000	MOBILE HOME TAX	0.00	0.00		0.00	0.00	0.00
Tort Immunity and Judgment Fund	80 R 1290 0000 00 000 000000	PAYMENT IN LIEU OF TAXES LIABILITY	0.00	0.00		0.00	0.00	0.00
Tort Immunity and Judgment Fund	80 R 1510 0000 00 000 000000	CHECKING INTEREST	0.00	0.00		0.00	0.00	0.00
Tort Immunity and Judgment Fund	80 R 1511 0000 00 000 000000	INVESTMENT INTEREST	1,400.00	136.90	0.00	732.69	667.31	47.67
Tort Immunity and Judgment Fund	80 R 1960 0000 00 000 000000	TIF SURPLUS DONATION	0.00	0.00		0.00	0.00	0.00
Tort Immunity and Judgment Fund	80 R 1999 0000 00 000 000000	OTHER-LOCAL SOURCES	0.00	0.00		0.00	0.00	0.00
Tort Immunity and Judgment Fund	80 R 1999 2220 00 000 000000	DIST 111 GROUP MEDICAL REVENUE	153,625.00	8,933.00	0.00	72,616.27	81,008.73	52.73
Tort Immunity and Judgment Fund	80 R 1999 2230 00 000 000000	DIST 111 GROUP DENTAL REVENUE	1,700.00	197.21	0.00	-75.57	1,775.57	104.45
Tort Immunity and Judgment Fund	80 R 2901 0000 00 000 000000	GRUNDY CO TIF EXT	0.00	0.00		0.00	0.00	0.00
Tort Immunity and Judgment Fund	80 R 4008 0000 00 000 000000	COPS GRANT CHANNAHON	0.00	0.00		0.00	0.00	0.00

54

Revenue Report

Fiscal Year: 2021-2022
Month: March

COUNTY OF GRUNDY SCHOOL DIST 111

Fund Description	Account Number	Account Description	Revised Budget	Monthly Activity	Pending Activity	Available Funds	Year to Date Activity	Percent of Budget Used
Tort Immunity and Judgment Fund	80 R 4009 0000 00 000 000000	COPS GRANT MINOOKA	0.00	0.00		0.00	0.00	0.00
Tort Immunity and Judgment Fund	80 R 7130 0000 00 000 000000	TRANS FROM ED TORT	0.00	0.00		0.00	0.00	0.00
Tort Immunity and Judgment Fund	80 R 7990 0000 00 000 000000	TRANS FROM OBM TORT	0.00	0.00		0.00	0.00	0.00
80 - -----	Tort Immunity and Judgment	TRANS FROM OBM TORT	1,381,714.85	9,267.11	0.00	478,052.89	903,661.96	
Fire Prevention & Safety Fund	90 R 1110 0000 00 000 000000	PRIOR YEAR TAXES	0.00	0.00		0.00	0.00	0.00
Fire Prevention & Safety Fund	90 R 1111 0000 00 000 000000	GRUNDY CO TAXES	295,864.47	0.00	0.00	4,008.36	291,856.11	98.65
Fire Prevention & Safety Fund	90 R 1112 0000 00 000 000000	KENDALL CO TAXES	42,256.17	0.00	0.00	496.46	41,759.71	98.83
Fire Prevention & Safety Fund	90 R 1113 0000 00 000 000000	WILL CO TAXES	235,453.68	0.00	0.00	476.18	234,977.50	99.80
Fire Prevention & Safety Fund	90 R 1114 0000 00 000 000000	GRUNDY CO EDPA SURPLUS	0.00	0.00		0.00	0.00	0.00
Fire Prevention & Safety Fund	90 R 1122 0000 00 000 000000	KENDALL CO-EARLY DISTR	47,273.67	0.00		47,273.67	0.00	0.00
Fire Prevention & Safety Fund	90 R 1123 0000 00 000 000000	WILL CO-EARLY DISTR	228,293.06	0.00		228,293.06	0.00	0.00
Fire Prevention & Safety Fund	90 R 1210 0000 00 000 000000	MOBIL HOME TAX	0.00	0.00		0.00	0.00	55
Fire Prevention & Safety Fund	90 R 1290 0000 00 000 000000	PAYMENT IN LIEU OF TAXES FIRE SAFETY	0.00	0.00		0.00	0.00	0.00
Fire Prevention & Safety Fund	90 R 1510 0000 00 000 000000	CHECKING INTEREST	0.00	0.00		0.00	0.00	0.00
Fire Prevention & Safety Fund	90 R 1511 0000 00 000 000000	INVESTMENT INTEREST	4,300.00	123.39	0.00	3,335.18	964.82	22.44
Fire Prevention & Safety Fund	90 R 1960 0000 00 000 000000	TIF SURPLUS DONATION	0.00	0.00		0.00	0.00	0.00
Fire Prevention & Safety Fund	90 R 1999 0000 00 000 000000	OTHER-LOCAL SOURCES	0.00	0.00		0.00	0.00	0.00
Fire Prevention & Safety Fund	90 R 2901 0000 00 000 000000	GRUNDY CO TIF EXT	0.00	0.00		0.00	0.00	0.00
Fire Prevention & Safety Fund	90 R 7210 0000 00 000 000000	PRIN ON BONDS SOLD	0.00	0.00		0.00	0.00	0.00
Fire Prevention & Safety Fund	90 R 7220 0000 00 000 000000	PREMIUM ON BONDS SOLD	0.00	0.00		0.00	0.00	0.00
90 - -----	Fire Prevention & Safety	PREMIUM ON BONDS SOLD	853,441.05	123.39	0.00	283,882.91	569,558.14	
Grand Totals:			60,428,034.30	1,605,430.54	-642.20	16,320,223.23	44,108,878.07	

Expenditure Report

Fiscal Year: 2021-2022
Month: March

COUNTY OF GRUNDY SCHOOL DIST 111

Fund Description	Account	Account Description	Revised Budget	MTD Activity	Encumbrance	Pending Activity	Available Funds	Year to Date Activity	Percent of Budget Used
Education Fund	111134900	ESSER I Digital Equity Grant	0.00	0.00	0.00	0.00	-1,768.00	1,768.00	0.00
Education Fund	111137000	ESSER I Digital Equity Grant	185,000.00	0.00	3,996.00	0.00	10,910.72	170,093.28	91.94
Education Fund	11130100	TITLE 1 SALARIES	0.00	1,308.72	0.00	0.00	-24,395.15	24,395.15	0.00
Education Fund	1011130110	HIGH SCHOOL	0.00	0.00	0.00	0.00	0.00	0.00	0.00
Education Fund	11130110	DETENTION HALL SUPVSN	0.00	1,983.20	0.00	0.00	-10,744.80	10,744.80	0.00
Education Fund	11130127	ELL INSTRUCTION	0.00	0.00	0.00	0.00	0.00	0.00	0.00
Education Fund	1113011002	ART SALARY	186,227.04	15,518.92	0.00	0.00	47,271.24	138,955.80	74.62
Education Fund	1113011005	ENGLISH/DRAMA SALARY	1,695,683.28	143,860.53	0.00	0.00	441,447.08	1,254,236.20	73.97
Education Fund	1113011006	FOREIGN LANG SALARY	798,294.48	65,224.65	0.00	0.00	208,400.51	589,893.97	73.89
Education Fund	1113011011	MATH SALARY	1,345,195.44	112,330.82	0.00	0.00	326,735.93	1,018,459.51	75.71
Education Fund	1113011012	MUSIC SALARY	254,266.08	21,188.84	0.00	0.00	59,950.53	194,315.55	57 76.42
Education Fund	1113011013	NATURAL SCIENCE	1,352,051.28	112,640.14	0.00	0.00	341,211.25	1,010,840.03	74.76
Education Fund	1113011015	SOCIAL SCIENCE SALARY	1,298,241.60	108,291.86	0.00	0.00	328,404.65	969,836.95	74.70
Education Fund	1113011021	DRIVER ED SALARY	0.00	0.00	0.00	0.00	0.00	0.00	0.00
Education Fund	1113011121	DRIVER ED SUMMER	0.00	0.00	0.00	0.00	0.00	0.00	0.00
Education Fund	1113011027	DEPT CHAIR SALARY	767,620.56	63,968.38	0.00	0.00	205,522.22	562,098.34	73.23
Education Fund	1113011050	PHYS ED SALARY	1,168,552.08	97,386.08	0.00	0.00	300,915.51	867,636.57	74.25
Education Fund	11130111	OVERLOAD	106,191.36	8,849.28	0.00	0.00	27,701.82	78,489.54	73.91
Education Fund	11130112	PLAN TIME	203,037.12	17,322.60	0.00	0.00	48,752.39	154,284.73	75.99
Education Fund	11130120	CAMPUS MONITOR	0.00	0.00	0.00	0.00	0.00	0.00	0.00
Education Fund	11130121	SUB TEACHER SALARY	284,290.32	30,735.92	0.00	0.00	104,088.54	180,201.78	63.39
Education Fund	11130122	MENTORING	14,000.00	0.00	0.00	0.00	8,762.38	5,237.62	37.41
Education Fund	11130125	SUMMER CURRIC	9,500.00	0.00	0.00	0.00	9,214.00	286.00	3.01
Education Fund	11130126	POST RETIREMENT	140,000.00	0.00	0.00	0.00	116,534.27	23,465.73	16.76

Expenditure Report

Fiscal Year: 2021-2022
Month: March

COUNTY OF GRUNDY SCHOOL DIST 111

Fund Description	Account	Account Description	Revised Budget	MTD Activity	Encumbrance	Pending Activity	Available Funds	Year to Date Activity	Percent of Budget Used
Education Fund	11130128	SUMMER SCHOOL SALARY	26,000.00	0.00	0.00	0.00	26,000.00	0.00	0.00
Education Fund	11130130	HOMEBOUND	4,000.00	105.19	0.00	0.00	2,145.80	1,854.20	46.36
Education Fund	10-1130-211	OVERLOAD (IC)	15,000.00	0.00	0.00	0.00	15,000.00	0.00	0.00
Education Fund	1113021	INSTRUCTIONAL TRS	12,746.16	1,062.25	0.00	0.00	3,093.47	9,652.69	75.73
Education Fund	11130211	SUB TEACHER TRS	52,529.04	5,478.94	0.00	0.00	13,774.45	38,754.59	73.78
Education Fund	11130212	MENTORING TRS	2,700.00	0.00	0.00	0.00	1,617.83	1,082.17	40.08
Education Fund	11130213	SUMMER CURRIC TRS	500.00	0.00	0.00	0.00	465.67	34.33	6.87
Education Fund	111302135	TRS PENALTY	16,000.00	0.00	0.00	0.00	12,539.74	3,460.26	21.63
Education Fund	1113021101	INSTRUCTIONAL TRS	0.00	0.00	0.00	0.00	0.00	0.00	0.00
Education Fund	1113021102	ART TRS	22,352.16	1,862.70	0.00	0.00	5,533.00	16,819.16	75.25
Education Fund	1113021105	ENGLISH/DRAMA TRS	203,530.80	17,267.49	0.00	0.00	51,750.93	151,779.87	58 74.57
Education Fund	1113021106	FOREIGN LANGUAGE TRS	95,817.84	7,828.83	0.00	0.00	24,426.39	71,391.45	74.51
Education Fund	111302111	MATH TRS	161,462.40	13,482.90	0.00	0.00	37,956.93	123,505.47	76.49
Education Fund	1113021112	MUSIC TRS	30,518.16	2,543.22	0.00	0.00	6,974.57	23,543.59	77.15
Education Fund	1113021113	NAT SCI TRS	162,284.64	13,520.07	0.00	0.00	39,829.33	122,455.31	75.46
Education Fund	1113021115	SOC SCI TRS	155,826.48	12,998.16	0.00	0.00	38,377.81	117,448.67	75.37
Education Fund	1113021121	DRIVER ED TRS	0.00	0.00	0.00	0.00	0.00	0.00	0.00
Education Fund	1113021127	INSTR LEADER TRS	94,055.52	7,837.96	0.00	0.00	24,648.62	69,406.90	73.79
Education Fund	1113021150	PHYS ED TRS	140,260.32	11,689.07	0.00	0.00	35,188.36	105,071.96	74.91
Education Fund	10-1130-	DEPT CHAIR SALARY (GTL)	0.00	0.00	0.00	0.00	0.00	0.00	0.00
Education Fund	10-1130-222	DIST 111 GROUP MEDICAL	3,000,000.00	226,057.20	0.00	0.00	476,542.91	2,523,457.09	84.12
Education Fund	10-1130-	HIGH SCHOOL	0.00	0.00	0.00	0.00	0.00	0.00	0.00
Education Fund		TEACHING GROUP INS	2,646.48	85.23	0.00	0.00	1,204.87	1,441.61	54.47
Education Fund		10 E 1130 2220 00 300	0.00	0.00	0.00	0.00	-1,418.88	1,418.88	0.00

Expenditure Report

Fiscal Year: 2021-2022
Month: March

COUNTY OF GRUNDY SCHOOL DIST 111

Fund Description	Account	Account Description	Revised Budget	MTD Activity	Encumbrance	Pending Activity	Available Funds	Year to Date Activity	Percent of Budget Used
Education Fund	1113022201	TEACHING GROUP INS	0.00	0.00	0.00	0.00	0.00	0.00	0.00
Education Fund	1113022202	ART GROUP INS	44,946.00	3,745.50	0.00	0.00	11,236.50	33,709.50	75.00
Education Fund	1113022205	ENGLISH GROUP INS	393,926.40	33,529.68	0.00	0.00	103,132.13	290,794.27	73.82
Education Fund	1113022206	FOREIGN LANG GROUP	234,111.12	19,509.26	0.00	0.00	59,289.29	174,821.83	74.67
Education Fund	1113022211	MATH GROUP INS	330,884.64	27,698.78	0.00	0.00	79,957.41	250,927.23	75.84
Education Fund	1113022212	MUSIC GROUP INS	56,149.20	4,679.10	0.00	0.00	14,032.50	42,116.70	75.01
Education Fund	1113022213	NAT SCI GROUP INS	305,990.16	26,159.36	0.00	0.00	71,767.28	234,222.88	76.55
Education Fund	1113022215	SOC SCI GROUP INS	249,614.16	20,957.46	0.00	0.00	62,518.56	187,095.60	74.95
Education Fund	1113022221	DRIVER ED GROUP INS	0.00	0.00	0.00	0.00	0.00	0.00	0.00
Education Fund	1113022225	CAMPUS MONITOR GROUP	0.00	0.00	0.00	0.00	0.00	0.00	0.00
Education Fund	1113022227	INSTR LDR GROUP	198,651.12	16,554.26	0.00	0.00	50,916.26	147,734.86	59 74.37
Education Fund	1113022250	PHYS ED GROUP INS	243,803.52	24,203.32	0.00	0.00	46,002.46	197,801.06	81.13
Education Fund		DIST 111 GROUP DENTAL	329,748.00	16,140.50	0.00	0.00	198,406.43	131,341.57	39.83
Education Fund		10 E 1130 2230 00 300	0.00	0.00	0.00	0.00	-73.60	73.60	0.00
Education Fund		ART DENTAL INSURANCE	883.20	75.56	0.00	0.00	214.92	668.28	75.67
Education Fund		ENGLISH DENTAL INS	8,666.40	741.44	0.00	0.00	2,185.21	6,481.19	74.79
Education Fund		FOREIGN LANG DENTAL	4,857.60	415.58	0.00	0.00	1,175.67	3,681.93	75.80
Education Fund		MATH DENTAL INS	7,065.60	604.48	0.00	0.00	1,667.05	5,398.55	76.41
Education Fund		MUSIC DENTAL INS	1,324.80	113.34	0.00	0.00	322.38	1,002.42	75.67
Education Fund		NAT SCI DENTAL INS	7,507.20	642.26	0.00	0.00	1,772.05	5,735.15	76.40
Education Fund		SOC SCI DENTAL INS	6,789.60	579.76	0.00	0.00	1,698.92	5,090.68	74.98
Education Fund		DEPT CHAIR INS	8,832.72	755.90	0.00	0.00	2,226.20	6,606.52	74.80
Education Fund		PHYS ED DENTAL INS	4,857.60	453.36	0.00	0.00	1,013.52	3,844.08	79.14
Education Fund	11131230	COLLEGE TUITION REIMB	70,000.00	2,220.00	0.00	0.00	5,608.12	64,391.88	91.99

Expenditure Report

Fiscal Year: 2021-2022
Month: March

COUNTY OF GRUNDY SCHOOL DIST 111

Fund Description	Account	Account Description	Revised Budget	MTD Activity	Encumbrance	Pending Activity	Available Funds	Year to Date Activity	Percent of Budget Used
Education Fund		10 E 1130 2340 13 300	0.00	0.00	0.00	0.00	-500.00	500.00	0.00
Education Fund	1113030006	FOREIGN LANG CONTR	1,150.00	0.00	0.00	0.00	1,150.00	0.00	0.00
Education Fund	1113030006	FOREIGN LANG CONT	0.00	0.00	0.00	0.00	0.00	0.00	0.00
Education Fund	1110030012	BAND PURCHASE SERV	12,500.00	0.00	2,000.00	0.00	-1,360.45	11,860.45	94.88
Education Fund	1110030112	CHORUS PURCHASE SERV	10,000.00	828.00	0.00	0.00	5,474.55	4,525.45	45.25
Education Fund	1110030212	STRINGS PURCHASE	0.00	0.00	0.00	0.00	0.00	0.00	0.00
Education Fund	1110030012	BAND CONT SERV S	0.00	0.00	0.00	0.00	0.00	0.00	0.00
Education Fund	1110030112	CHORUS CONT SERV S	0.00	0.00	0.00	0.00	0.00	0.00	0.00
Education Fund	1110030212	STRINGS CONT SERV S	0.00	0.00	0.00	0.00	0.00	0.00	0.00
Education Fund	1113030021	DRIVER ED CONTRACT	0.00	0.00	0.00	0.00	0.00	0.00	0.00
Education Fund	1113031025	POLICE LIAISON	0.00	0.00	0.00	0.00	0.00	0.00	60 0.00
Education Fund	1113031125	EVENT SECURITY	0.00	0.00	0.00	0.00	0.00	0.00	0.00
Education Fund	11131314	CURRIC DEVEL/LRNG OBJ	0.00	0.00	0.00	0.00	0.00	0.00	0.00
Education Fund	11131315	STAFF DEVELOPMENT	0.00	0.00	0.00	0.00	0.00	0.00	0.00
Education Fund	11130322	TOWEL CONTRACT SERV	0.00	0.00	0.00	0.00	0.00	0.00	0.00
Education Fund	1113032302	ART CONTRACT SERV	0.00	0.00	1,370.00	0.00	-1,370.00	0.00	0.00
Education Fund	1113032302	ART CONT SERV S	0.00	0.00	0.00	0.00	0.00	0.00	0.00
Education Fund	1113032305	ENGLISH CONTRACT SERV	5,000.00	0.00	438.00	0.00	4,562.00	0.00	0.00
Education Fund	1113032305	ENGLISH CONT SERV S	0.00	0.00	0.00	0.00	0.00	0.00	0.00
Education Fund	1110032312	BAND REPAIR & MAINT	6,000.00	19.99	0.00	0.00	1,942.12	4,057.88	67.63
Education Fund	1110032412	CHORUS REPAIR & MAINT	2,200.00	0.00	85.00	0.00	1,605.00	510.00	23.18
Education Fund	1110032512	STRINGS REPAIR & MAINT	0.00	0.00	0.00	0.00	0.00	0.00	0.00
Education Fund	1110032312	BAND REPAIR & MAINT S	0.00	0.00	0.00	0.00	0.00	0.00	0.00
Education Fund	1110032412	CHORUS REPAIR & MAINT	0.00	0.00	0.00	0.00	-340.00	340.00	0.00

Expenditure Report

Fiscal Year: 2021-2022
Month: March

COUNTY OF GRUNDY SCHOOL DIST 111

Fund Description	Account	Account Description	Revised Budget	MTD Activity	Encumbrance	Pending Activity	Available Funds	Year to Date Activity	Percent of Budget Used
Education Fund	1110032512	STRINGS REPAIR & MAINT	0.00	0.00	0.00	0.00	0.00	0.00	0.00
Education Fund	1113032313	NAT SCI CONTRACT SERV	3,000.00	0.00	0.00	0.00	3,000.00	0.00	0.00
Education Fund	1113032313	NAT SCI CONT SERV S	0.00	0.00	0.00	0.00	0.00	0.00	0.00
Education Fund	1113032315	SOC SCI CONTRACT SERV	189.00	0.00	0.00	0.00	0.00	189.00	100.00
Education Fund	1113032315	SOC SCI CONT SERV S	0.00	0.00	0.00	0.00	0.00	0.00	0.00
Education Fund	1113032350	PHYS ED CONTRACT SERV	3,440.00	2,838.00	0.00	0.00	-3,367.00	6,807.00	197.88
Education Fund	1113032351	BOWING COSTS	0.00	0.00	0.00	0.00	0.00	0.00	0.00
Education Fund	1113032350	PHYS ED CONT SERV S	0.00	0.00	0.00	0.00	0.00	0.00	0.00
Education Fund	11130332	GENERAL EDUCATION	1,000.00	0.00	0.00	0.00	947.22	52.78	5.28
Education Fund	11131332	TYPE 75 TRAVEL	0.00	0.00	0.00	0.00	0.00	0.00	0.00
Education Fund	11130380	UNEMPLOYMENT	0.00	-1,151.97	0.00	0.00	-3,832.95	3,832.95	61 0.00
Education Fund	11130381	WORKERS COMP	0.00	0.00	0.00	0.00	0.00	0.00	0.00
Education Fund	1113038021	DRIVER ED CAR	0.00	0.00	0.00	0.00	0.00	0.00	0.00
Education Fund	11130400	TITLE 1 SUPPLIES	0.00	0.00	0.00	0.00	0.00	0.00	0.00
Education Fund	1113040005	ENGLISH RESALE	0.00	0.00	0.00	0.00	0.00	0.00	0.00
Education Fund	1113040011	MATH SUPPLIES RESALE	0.00	0.00	0.00	0.00	0.00	0.00	0.00
Education Fund	1113040050	PHYS ED RESALE	4,628.00	0.00	0.00	0.00	1,634.87	2,993.13	64.67
Education Fund	1113040050	PHYS ED RESALE	0.00	0.00	0.00	0.00	0.00	0.00	0.00
Education Fund	11130410	GEN ED	20,000.00	0.00	0.00	0.00	3,164.58	16,835.42	84.18
Education Fund	11130411	ECOLAB GRANT SUPPLIES	0.00	0.00	0.00	0.00	0.00	0.00	0.00
Education Fund	11131410	CURRIC DEVEL/LRNG	0.00	0.00	0.00	0.00	0.00	0.00	0.00
Education Fund	11131411	STAFF DEVELOPMENT	0.00	0.00	0.00	0.00	0.00	0.00	0.00
Education Fund	11131412	TPI GRANT SUPPLIES	0.00	0.00	0.00	0.00	0.00	0.00	0.00
Education Fund	111304102	GEN ED SUPPLIES S	0.00	0.00	0.00	0.00	0.00	0.00	0.00

Expenditure Report

Fiscal Year: 2021-2022
Month: March

COUNTY OF GRUNDY SCHOOL DIST 111

Fund Description	Account	Account Description	Revised Budget	MTD Activity	Encumbrance	Pending Activity	Available Funds	Year to Date Activity	Percent of Budget Used
Education Fund	1113041002	ART SUPPLIES	17,880.00	4,803.48	332.30	0.00	1,730.21	15,817.49	88.46
Education Fund	1113041102	ART/COMP TECH	1,800.00	147.81	0.00	0.00	1,582.01	217.99	12.11
Education Fund	1113041002	ART SUPPLIES S	0.00	0.00	0.00	0.00	0.00	0.00	0.00
Education Fund	1113041102	ART/COMP TECH SUPPLY	0.00	0.00	0.00	0.00	0.00	0.00	0.00
Education Fund	1113041005	ENGLISH/DRAMA	1,744.00	0.00	0.00	0.00	1,744.00	0.00	0.00
Education Fund	1113041505	ENGLISH/COMP TECH	0.00	0.00	0.00	0.00	0.00	0.00	0.00
Education Fund	1113041005	ENGLISH/DRAMA SUPPLY	0.00	0.00	0.00	0.00	0.00	0.00	0.00
Education Fund	1113041505	ENGLISH/COMP TECH SUP	0.00	0.00	0.00	0.00	0.00	0.00	0.00
Education Fund	1113041006	FOREIGN LANG SUPPLIES	1,369.00	0.00	365.85	0.00	205.02	798.13	58.30
Education Fund	1113041106	FOREIGN LANG/COMP	0.00	0.00	0.00	0.00	0.00	0.00	0.00
Education Fund	1113041006	FORN LANG SUPPLIES S	0.00	0.00	0.00	0.00	0.00	0.00	62 0.00
Education Fund	1113041106	FORN LANG COMP TECH S	0.00	0.00	0.00	0.00	0.00	0.00	0.00
Education Fund	1113041011	MATH SUPPLIES	2,265.00	51.12	764.63	0.00	335.79	1,164.58	51.42
Education Fund	1113041211	MATH/COMP TECH	389.00	0.00	0.00	0.00	75.56	313.44	80.58
Education Fund	1113041011	MATH SUPPLIES S	0.00	0.00	0.00	0.00	0.00	0.00	0.00
Education Fund	1113041211	MATH/COMP TECH SUP S	0.00	0.00	0.00	0.00	0.00	0.00	0.00
Education Fund	1110041012	BAND SUPPLIES	8,165.20	475.96	918.95	729.00	370.07	6,147.18	75.29
Education Fund	1110041112	CHORUS SUPPLIES	3,500.00	0.00	473.80	0.00	604.24	2,421.96	69.20
Education Fund	1110041212	STRINGS SUPPLIES	2,500.00	0.00	118.80	0.00	2,381.20	0.00	0.00
Education Fund	1113041012	BAND-CHORUS/COMP	0.00	0.00	0.00	0.00	0.00	0.00	0.00
Education Fund	1110041012	BAND SUPPLIES S	0.00	0.00	0.00	0.00	0.00	0.00	0.00
Education Fund	1110041112	GENERAL MUSIC	8,590.00	0.00	0.00	0.00	8,069.01	520.99	6.07
Education Fund	1110041212	STRINGS SUPPLIES S	0.00	0.00	0.00	0.00	0.00	0.00	0.00
Education Fund	1113041012	BAND-CHORUS/COMP	0.00	0.00	0.00	0.00	0.00	0.00	0.00

Expenditure Report

Fiscal Year: 2021-2022
Month: March

COUNTY OF GRUNDY SCHOOL DIST 111

Fund Description	Account	Account Description	Revised Budget	MTD Activity	Encumbrance	Pending Activity	Available Funds	Year to Date Activity	Percent of Budget Used
Education Fund	1113041013	NAT SCI SUPPLIES	21,150.00	507.15	148.86	0.00	15,798.41	5,202.73	24.60
Education Fund	1113041113	NAT SCI/COMP TECH	0.00	0.00	0.00	0.00	-7,860.00	7,860.00	0.00
Education Fund	1113041013	NAT SCI SUPPLIES S	0.00	0.00	0.00	0.00	-2,086.55	2,086.55	0.00
Education Fund	1113041113	NAT SCI/COMP TECH S	0.00	0.00	0.00	0.00	0.00	0.00	0.00
Education Fund	1113041015	SOC SCI SUPPLIES	5,000.00	0.00	0.00	0.00	2,084.17	2,915.83	58.32
Education Fund	1113041115	SOC SCI/COMP TECH	0.00	0.00	0.00	0.00	0.00	0.00	0.00
Education Fund	1113041015	SOC SCI SUPPLIES S	0.00	1,097.88	814.95	0.00	87.17	-902.12	0.00
Education Fund	1113041115	SCO SCI/COMP TECH S	0.00	0.00	0.00	0.00	0.00	0.00	0.00
Education Fund	1113041021	DRIVER ED SUPPLIES	0.00	0.00	0.00	0.00	0.00	0.00	0.00
Education Fund	1113041050	PHYS ED SUPPLIES	30,000.00	2,547.84	5,098.77	0.00	-75.89	24,977.12	83.26
Education Fund	1113041150	PHYS ED COMP TECH	500.00	0.00	0.00	0.00	500.00	0.00	63 0.00
Education Fund	1113041050	PHS ED SUPPLIES S	0.00	0.00	0.00	0.00	0.00	0.00	0.00
Education Fund	1113041150	PHYS ED COMP TECH	0.00	0.00	0.00	0.00	0.00	0.00	0.00
Education Fund	11130420	GENERAL EDUC	0.00	0.00	0.00	0.00	-13.46	13.46	0.00
Education Fund	111304202	GENERAL ED TEXTBOOKS	0.00	0.00	0.00	0.00	0.00	0.00	0.00
Education Fund	1113042002	ART TEXTBOOKS	0.00	0.00	0.00	0.00	0.00	0.00	0.00
Education Fund	1113042002	ART TEXTBOOKS S	0.00	0.00	0.00	0.00	0.00	0.00	0.00
Education Fund	1113042005	ENGLISH/DRAMA	7,000.00	0.00	0.00	0.00	3,705.29	3,294.71	47.07
Education Fund	1113042005	ENGLISH/DRAMA TEXTBK S	0.00	0.00	0.00	0.00	-722.52	722.52	0.00
Education Fund	1113042006	FOREIGN LANG	6,607.00	0.00	0.00	0.00	1,916.20	4,690.80	71.00
Education Fund	1113042006	FORN LANG TEXTBOOKS S	0.00	0.00	0.00	0.00	0.00	0.00	0.00
Education Fund	1113042011	MATH TEXTBOOKS	19,974.00	0.00	0.00	0.00	-0.13	19,974.13	100.00
Education Fund	1113042011	MATH TEXTBOOKS S	0.00	0.00	0.00	0.00	0.00	0.00	0.00
Education Fund	1110042012	BAND TEXTBOOKS	0.00	0.00	0.00	0.00	0.00	0.00	0.00

Expenditure Report

Fiscal Year: 2021-2022
Month: March

COUNTY OF GRUNDY SCHOOL DIST 111

Fund Description	Account	Account Description	Revised Budget	MTD Activity	Encumbrance	Pending Activity	Available Funds	Year to Date Activity	Percent of Budget Used
Education Fund	1110042112	MUSIC TEXTBOOKS	1,200.00	0.00	0.00	0.00	873.31	326.69	27.22
Education Fund	1110042212	STRINGS TEXTBOOKS	0.00	0.00	0.00	0.00	0.00	0.00	0.00
Education Fund	1110042012	BAND TEXTBOOKS S	0.00	0.00	0.00	0.00	0.00	0.00	0.00
Education Fund	1110042112	CHORUS TEXTBOOKS S	0.00	0.00	0.00	0.00	0.00	0.00	0.00
Education Fund	1110042212	STRINGS TEXTBOOKS S	0.00	0.00	0.00	0.00	0.00	0.00	0.00
Education Fund	1113042013	NAT SCI TEXTBOOKS	8,046.00	0.00	0.00	0.00	976.43	7,069.57	87.86
Education Fund	1113042013	NAT SCI TEXTBOOKS S	0.00	0.00	0.00	0.00	0.00	0.00	0.00
Education Fund	1113042015	SOC SCI TEXTBOOKS	16,000.00	0.00	0.00	0.00	16,000.00	0.00	0.00
Education Fund	1113042015	SOC SCI TEXTBOOKS S	0.00	0.00	0.00	0.00	0.00	0.00	0.00
Education Fund	1113042021	DRIVER ED TEXTBOOKS	0.00	0.00	0.00	0.00	0.00	0.00	0.00
Education Fund	1113042050	PHYS ED TEXTBOOKS	0.00	0.00	0.00	0.00	0.00	0.00	64 0.00
Education Fund	1113042050	PHS ED TEXTBOOKS S	0.00	0.00	0.00	0.00	0.00	0.00	0.00
Education Fund	1113043002	ART PERIODICALS	0.00	0.00	0.00	0.00	0.00	0.00	0.00
Education Fund	1113043002	ART PERIODICALS S	0.00	0.00	0.00	0.00	0.00	0.00	0.00
Education Fund	1113043005	ENGLISH PERIODICALS	0.00	0.00	0.00	0.00	0.00	0.00	0.00
Education Fund	1113043005	ENGLISH PERIODICALS S	0.00	0.00	0.00	0.00	0.00	0.00	0.00
Education Fund	1113043015	SOC SCI PERIODICALS	0.00	0.00	0.00	0.00	0.00	0.00	0.00
Education Fund	1113043015	SOC SCI PERIODICALS S	0.00	0.00	0.00	0.00	0.00	0.00	0.00
Education Fund	1113043050	PHYS ED PERIODICALS	0.00	0.00	0.00	0.00	0.00	0.00	0.00
Education Fund	1113043050	PHYS ED PERIODICALS S	0.00	0.00	0.00	0.00	0.00	0.00	0.00
Education Fund	1113049002	ART VIDEO/SOFTWARE	0.00	0.00	0.00	0.00	0.00	0.00	0.00
Education Fund	1113049002	ART VIDEO/SOFTWARE S	0.00	0.00	0.00	0.00	0.00	0.00	0.00
Education Fund	1113049005	ENGLISH	0.00	0.00	0.00	0.00	-5,000.00	5,000.00	0.00
Education Fund	1113049005	ENGLISH	0.00	0.00	0.00	0.00	0.00	0.00	0.00

Expenditure Report

Fiscal Year: 2021-2022
Month: March

COUNTY OF GRUNDY SCHOOL DIST 111

Fund Description	Account	Account Description	Revised Budget	MTD Activity	Encumbrance	Pending Activity	Available Funds	Year to Date Activity	Percent of Budget Used
Education Fund	1113049006	FOREIGN LANG	0.00	0.00	0.00	0.00	0.00	0.00	0.00
Education Fund	1113049006	FORN LANG	0.00	0.00	0.00	0.00	0.00	0.00	0.00
Education Fund	1113049011	MATH VIDEO/SOFTWARE	480.00	0.00	360.00	0.00	120.00	0.00	0.00
Education Fund	1113049011	MATH VIDEO/SOFTWARE S	0.00	0.00	0.00	0.00	0.00	0.00	0.00
Education Fund	1110049112	BAND VIDEO/SOFTWARE	0.00	0.00	0.00	0.00	0.00	0.00	0.00
Education Fund	1110049212	CHORUS	0.00	0.00	0.00	0.00	0.00	0.00	0.00
Education Fund	1110049312	STRINGS	0.00	0.00	0.00	0.00	0.00	0.00	0.00
Education Fund	1110049112	BAND VIDEO/SOFTWARE S	0.00	0.00	0.00	0.00	0.00	0.00	0.00
Education Fund	1110049212	CHORUS	0.00	0.00	0.00	0.00	0.00	0.00	0.00
Education Fund	1110049312	STRINGS	0.00	0.00	0.00	0.00	0.00	0.00	0.00
Education Fund	1113049013	NAT SCI	7,990.00	0.00	0.00	0.00	7,990.00	0.00	65 0.00
Education Fund	1113049013	NAT SCI	0.00	0.00	0.00	0.00	0.00	0.00	0.00
Education Fund	1113049015	SOC SCI	0.00	0.00	0.00	0.00	0.00	0.00	0.00
Education Fund	1113049015	SOC SCI	0.00	0.00	0.00	0.00	0.00	0.00	0.00
Education Fund	1113049021	DRIVER ED	0.00	0.00	0.00	0.00	0.00	0.00	0.00
Education Fund	1113049050	PE/HEALTH	0.00	0.00	0.00	0.00	0.00	0.00	0.00
Education Fund	1113049050	PHYS ED	0.00	0.00	0.00	0.00	0.00	0.00	0.00
Education Fund	1113054002	ART EQUIPMENT	0.00	0.00	0.00	0.00	0.00	0.00	0.00
Education Fund	1113054002	ART EQUIPMENT S	0.00	0.00	0.00	0.00	0.00	0.00	0.00
Education Fund	1113054005	ENGLISH EQUIPMENT	0.00	0.00	0.00	0.00	0.00	0.00	0.00
Education Fund	1113054005	ENGLISH EQUIPMENT S	0.00	0.00	0.00	0.00	0.00	0.00	0.00
Education Fund	1113054006	FOREIGN LANG	0.00	0.00	0.00	0.00	0.00	0.00	0.00
Education Fund	1113054006	FORN LANG EQUIPMENT S	0.00	0.00	0.00	0.00	0.00	0.00	0.00
Education Fund	1113054011	MATH EQUIPMENT	0.00	0.00	0.00	0.00	0.00	0.00	0.00

Expenditure Report

Fiscal Year: 2021-2022
Month: March

COUNTY OF GRUNDY SCHOOL DIST 111

Fund Description	Account	Account Description	Revised Budget	MTD Activity	Encumbrance	Pending Activity	Available Funds	Year to Date Activity	Percent of Budget Used
Education Fund	1113054011	MATH EQUIPMENT S	0.00	0.00	0.00	0.00	0.00	0.00	0.00
Education Fund	1110054012	BAND EQUIPMENT	51,649.80	6,399.48	0.00	0.00	39,127.58	12,522.22	24.24
Education Fund	1110054112	CHORUS EQUIPMENT	2,900.00	0.00	0.00	0.00	2,900.00	0.00	0.00
Education Fund	1110054212	STRINGS EQUIPMENT	0.00	0.00	0.00	0.00	0.00	0.00	0.00
Education Fund	1110054012	BAND EQUIPMENT S	0.00	0.00	0.00	0.00	0.00	0.00	0.00
Education Fund	1110054112	CHORUS EQUIPMENT S	0.00	0.00	0.00	0.00	0.00	0.00	0.00
Education Fund	1110054212	STRINGS EQUIPMENT S	0.00	0.00	0.00	0.00	0.00	0.00	0.00
Education Fund	1113054013	NAT SCI EQUIPMENT	0.00	0.00	0.00	0.00	0.00	0.00	0.00
Education Fund	1113054013	NAT SCI EQUIPMENT S	0.00	0.00	0.00	0.00	0.00	0.00	0.00
Education Fund	1113054015	SOC SCI EQUIPMENT	0.00	0.00	0.00	0.00	0.00	0.00	0.00
Education Fund	1113054015	SOC SCI EQUIPMENT S	0.00	0.00	0.00	0.00	0.00	0.00	66 0.00
Education Fund	1113054021	DRIVER ED EQUIPMENT	0.00	0.00	0.00	0.00	0.00	0.00	0.00
Education Fund	1113054050	PHYS ED EQUIPMENT	0.00	0.00	0.00	0.00	-85.57	85.57	0.00
Education Fund	1113054050	PHYS ED EQUIPMENT S	0.00	0.00	0.00	0.00	0.00	0.00	0.00
Education Fund	1113055021	DRIVER ED VEHICLES	0.00	0.00	0.00	0.00	0.00	0.00	0.00
Education Fund	11130642	JJC TUITION	0.00	0.00	0.00	0.00	0.00	0.00	0.00
Education Fund	1113064002	ART DUES/FEES/LIT	0.00	0.00	0.00	0.00	0.00	0.00	0.00
Education Fund	1113064005	ENGLISH DUES/FEES	0.00	0.00	0.00	0.00	0.00	0.00	0.00
Education Fund	1113064005	ENGLISH DUES/FEES/LIT	0.00	0.00	0.00	0.00	0.00	0.00	0.00
Education Fund	1113064006	FOREIGN LANG	0.00	0.00	0.00	0.00	0.00	0.00	0.00
Education Fund	1113064006	FORN LANG	0.00	0.00	0.00	0.00	0.00	0.00	0.00
Education Fund	1113064011	MATH DUES & FEES	0.00	0.00	0.00	0.00	0.00	0.00	0.00
Education Fund	1113064011	MATH DUES/FEES/LIT S	0.00	0.00	0.00	0.00	0.00	0.00	0.00
Education Fund	1110064012	BAND CLINICS	1,500.00	0.00	0.00	0.00	1,500.00	0.00	0.00

Expenditure Report

Fiscal Year: 2021-2022
Month: March

COUNTY OF GRUNDY SCHOOL DIST 111

Fund Description	Account	Account Description	Revised Budget	MTD Activity	Encumbrance	Pending Activity	Available Funds	Year to Date Activity	Percent of Budget Used
Education Fund	1110064112	CHORUS CLINICS	750.00	0.00	0.00	0.00	750.00	0.00	0.00
Education Fund	1110064212	STRINGS CLINICS	0.00	0.00	0.00	0.00	0.00	0.00	0.00
Education Fund	1110064312	BAND ENTRY FEES	5,485.00	1,100.00	0.00	0.00	4,860.00	625.00	11.39
Education Fund	1110064412	CHORUS ENTRY FEES	1,500.00	0.00	225.00	0.00	281.00	994.00	66.27
Education Fund	1110064512	STRINGS ENTRY FEES	2,100.00	0.00	0.00	0.00	2,100.00	0.00	0.00
Education Fund	1110064012	BAND CLINICS S	0.00	0.00	0.00	0.00	0.00	0.00	0.00
Education Fund	1110064112	CHORUS CLINICS S	0.00	0.00	0.00	0.00	0.00	0.00	0.00
Education Fund	1110064212	STRINGS CLINICS S	0.00	0.00	0.00	0.00	0.00	0.00	0.00
Education Fund	1110064312	BAND ENTRY FEES S	0.00	0.00	0.00	0.00	0.00	0.00	0.00
Education Fund	1110064412	CHORUS ENTRY FEES S	0.00	0.00	0.00	0.00	0.00	0.00	0.00
Education Fund	1110064512	STRINGS ENTRY FEES S	0.00	0.00	0.00	0.00	0.00	0.00	67 0.00
Education Fund	1113064013	NAT SCI DUES/FEES/LIT	750.00	0.00	0.00	0.00	750.00	0.00	0.00
Education Fund	1113064113	SCIENCE FIELD TRIP	0.00	0.00	0.00	0.00	0.00	0.00	0.00
Education Fund	1113064013	NAT SCI DUES/FEES/LIT S	0.00	0.00	0.00	0.00	0.00	0.00	0.00
Education Fund	1113064015	SOC SCI DUES/FEES/LIT	0.00	0.00	0.00	0.00	0.00	0.00	0.00
Education Fund	1113064015	SOC SCI DUES/FEES/LIT S	0.00	0.00	0.00	0.00	0.00	0.00	0.00
Education Fund	1113064021	DRIVER ED DUES/FEES/LIT	0.00	0.00	0.00	0.00	0.00	0.00	0.00
Education Fund	1113064050	PHYS ED DUES/FEES/LIT	0.00	0.00	0.00	0.00	0.00	0.00	0.00
Education Fund	1113064050	PHYS ED DUES/FEES/LIT S	0.00	0.00	0.00	0.00	0.00	0.00	0.00
Education Fund	11130800	HOMEBOUND/HOP REG ED	0.00	0.00	0.00	0.00	0.00	0.00	0.00
Education Fund	11130690	REFUND ACCOUNT	5,000.00	0.00	0.00	0.00	5,000.00	0.00	0.00
Education Fund	11200110	SPECIAL ED SALARY	1,272,122.16	105,481.85	0.00	0.00	338,166.70	933,955.46	73.42
Education Fund	11200111	SPECIAL ED AIDES	0.00	0.00	0.00	0.00	0.00	0.00	0.00
Education Fund	11200112	IDEA PART B SP ED	113,031.60	10,058.06	0.00	0.00	18,940.94	94,090.66	83.24

Expenditure Report

Fiscal Year: 2021-2022
Month: March

COUNTY OF GRUNDY SCHOOL DIST 111

Fund Description	Account	Account Description	Revised Budget	MTD Activity	Encumbrance	Pending Activity	Available Funds	Year to Date Activity	Percent of Budget Used
Education Fund	11200113	IDEA PART B SP ED	37,381.44	3,115.12	0.00	0.00	9,345.36	28,036.08	75.00
Education Fund	11200114	IDEA PART B SP ED	0.00	0.00	0.00	0.00	0.00	0.00	0.00
Education Fund	11200211	SPECIAL ED TRS	152,692.32	12,660.81	0.00	0.00	39,388.69	113,303.63	74.20
Education Fund	11200222	SPECIAL ED INSURANCE	268,413.36	23,005.18	0.00	0.00	59,178.66	209,234.70	77.95
Education Fund		SPECIAL ED AIDES INS	0.00	0.00	0.00	0.00	0.00	0.00	0.00
Education Fund		IDEA PART B SP ED	8,803.44	696.94	0.00	0.00	1,082.64	7,720.80	87.70
Education Fund		IDEA PART B SP ED	8,520.00	710.00	0.00	0.00	2,130.00	6,390.00	75.00
Education Fund	11200223	IDEA PART B SP ED	0.00	0.00	0.00	0.00	0.00	0.00	0.00
Education Fund		SPEC ED DENTAL INS	8,390.40	717.82	0.00	0.00	2,046.20	6,344.20	75.61
Education Fund		IDEA SEC DENTAL INS	441.60	37.78	0.00	0.00	107.46	334.14	75.67
Education Fund	11200300	SPECIAL ED PURCHASE	189.36	113.82	0.00	0.00	-731.14	920.50	68486.11
Education Fund	11200301	IDEA GRANT PURCHASE	1,437.12	0.00	0.00	0.00	-7,276.50	8,713.62	606.33
Education Fund	11200311	COOP HOUSING ASSESS	0.00	0.00	0.00	0.00	0.00	0.00	0.00
Education Fund	11200312	COOP ADMIN ASSESS	0.00	0.00	0.00	0.00	0.00	0.00	0.00
Education Fund	11200410	SPECIAL ED SUPPLIES	3,500.00	0.00	349.95	0.00	1,827.07	1,322.98	37.80
Education Fund	11200411	SPECIAL ED COMP TECH	2,600.00	0.00	0.00	0.00	2,600.00	0.00	0.00
Education Fund	11200412	IDEA PART B SP ED	2,713.00	1,590.57	20.98	0.00	-283.28	2,975.30	109.67
Education Fund	11200420	SPECIAL ED TEXTBOOKS	150.00	0.00	0.00	0.00	150.00	0.00	0.00
Education Fund	11200490	SPECIAL ED	0.00	0.00	0.00	0.00	0.00	0.00	0.00
Education Fund	11200500	IDEA PART B SP ED	9,500.00	0.00	0.00	0.00	6,870.95	2,629.05	27.67
Education Fund	11200641	SPECIAL ED - OTHER	1,800.00	0.00	0.00	17.49	1,645.87	136.64	7.59
Education Fund	11200640	SPECIAL ED	0.00	0.00	0.00	0.00	0.00	0.00	0.00
Education Fund	11200800	COOP TUITION	0.00	0.00	0.00	0.00	0.00	0.00	0.00
Education Fund	11200801	OUT OF DIST TUITION	0.00	0.00	0.00	0.00	0.00	0.00	0.00

Expenditure Report

Fiscal Year: 2021-2022
Month: March

COUNTY OF GRUNDY SCHOOL DIST 111

Fund Description	Account	Account Description	Revised Budget	MTD Activity	Encumbrance	Pending Activity	Available Funds	Year to Date Activity	Percent of Budget Used
Education Fund	11200802	COOP HOMEBOUND/HOSP	35,614.16	5,535.40	0.00	1,521.52	-7,586.74	41,679.38	117.03
Education Fund	11250211	COOP TRS	0.00	0.00	0.00	0.00	0.00	0.00	0.00
Education Fund	11250311	COOP HOUSING ASSESS	0.00	0.00	0.00	0.00	0.00	0.00	0.00
Education Fund	11250312	COOP ADMN ASSESS	0.00	0.00	0.00	0.00	0.00	0.00	0.00
Education Fund	11250800	COOP TUITION	0.00	0.00	0.00	0.00	0.00	0.00	0.00
Education Fund	11250801	OUT OF DIST TUITION	0.00	0.00	0.00	0.00	0.00	0.00	0.00
Education Fund	11250802	COOP HOMEBOUND/HOSP	0.00	0.00	0.00	0.00	0.00	0.00	0.00
Education Fund	1140041011	CTE SALARY	284,933.52	23,867.66	0.00	0.00	74,430.31	210,503.21	73.88
Education Fund	1140011010	INDUSTRIAL TECH SALARY	188,292.96	15,299.88	0.00	0.00	52,222.75	136,070.21	72.27
Education Fund	11400211	VOC ED GRANT TRS	34,200.48	2,864.82	0.00	0.00	8,712.06	25,488.42	74.53
Education Fund	1140021110	INDUSTRIAL TECH TRS	22,600.08	1,836.39	0.00	0.00	6,131.86	16,468.22	69 72.87
Education Fund	1140021111	CTE TRS	0.00	0.00	0.00	0.00	0.00	0.00	0.00
Education Fund	10-1400-	CTE SALARY (BMF 2)	80,846.64	6,737.22	0.00	0.00	24,018.23	56,828.41	70.29
Education Fund	1140022210	IND TECH GROUP INS	63,120.48	5,260.04	0.00	0.00	15,780.12	47,340.36	75.00
Education Fund		CTE DENTAL INS	1,766.40	151.12	0.00	0.00	470.92	1,295.48	73.34
Education Fund		IND TECH DENTAL INS	1,324.80	113.34	0.00	0.00	322.38	1,002.42	75.67
Education Fund	1140032310	IND TECH REPAIR/MAINT	25,000.00	0.00	276.98	0.00	22,603.46	2,119.56	8.48
Education Fund	1140032310	IND TECH REPAIR/MAINT S	0.00	0.00	0.00	0.00	0.00	0.00	0.00
Education Fund	1140041032	CTEIG SUPPLIES	0.00	0.00	0.00	0.00	0.00	0.00	0.00
Education Fund	11400410	VOC ED GRANT SUPPLIES	0.00	0.00	0.00	0.00	0.00	0.00	0.00
Education Fund	1140041010	IND ARTS COMP TECH	0.00	0.00	0.00	0.00	0.00	0.00	0.00
Education Fund	1140041110	IND TECH SUPPLIES	68,412.00	9,318.07	12,365.01	39.98	9,822.40	46,184.61	67.51
Education Fund	1140041210	ECO LAB GRANT	0.00	0.00	0.00	0.00	0.00	0.00	0.00
Education Fund	1140041010	IND TECH/COMP TECH S	0.00	0.00	0.00	0.00	0.00	0.00	0.00

Expenditure Report

Fiscal Year: 2021-2022
Month: March

COUNTY OF GRUNDY SCHOOL DIST 111

Fund Description	Account	Account Description	Revised Budget	MTD Activity	Encumbrance	Pending Activity	Available Funds	Year to Date Activity	Percent of Budget Used
Education Fund	1140041110	IND TECH SUPPLIES S	0.00	0.00	0.00	0.00	0.00	0.00	0.00
Education Fund	1140042010	IND TECH TEXTBOOKS	0.00	0.00	0.00	0.00	0.00	0.00	0.00
Education Fund	1140042010	IND TECH TEXTBOOKS S	0.00	0.00	0.00	0.00	0.00	0.00	0.00
Education Fund	11400490	IND TECH	0.00	0.00	0.00	0.00	0.00	0.00	0.00
Education Fund	114004902	IND TECH	0.00	0.00	0.00	0.00	0.00	0.00	0.00
Education Fund	1140054010	IND TECH EQUIPMENT	0.00	0.00	0.00	0.00	0.00	0.00	0.00
Education Fund	1140054010	IND TECH EQUIPMENT S	0.00	0.00	0.00	0.00	0.00	0.00	0.00
Education Fund	11400640	IND TECH DUES/FEES/LIT	3,200.00	0.00	0.00	0.00	0.00	3,200.00	100.00
Education Fund	114006402	IND TECH DUES/FEES/LIT	0.00	0.00	0.00	0.00	0.00	0.00	0.00
Education Fund	11459800	GAVC TUITION	0.00	0.00	0.00	0.00	0.00	0.00	0.00
Education Fund	1140111001	AG SALARY	236,962.56	19,746.88	0.00	0.00	60,915.24	176,047.32	70 74.29
Education Fund	1140121101	AG TRS	28,442.40	2,370.20	0.00	0.00	7,137.36	21,305.04	74.91
Education Fund	1140122201	AG GROUP INS	35,564.40	2,963.70	0.00	0.00	8,891.10	26,673.30	75.00
Education Fund		AG DENTAL INS	883.20	75.56	0.00	0.00	214.92	668.28	75.67
Education Fund	1140130001	AG CONTRACT SERV	1,500.00	0.00	0.00	0.00	450.00	1,050.00	70.00
Education Fund	1140130001	AG CONT SERVICE S	0.00	0.00	0.00	0.00	0.00	0.00	0.00
Education Fund	1140139001	AG GRANT PUR SERV	0.00	0.00	0.00	0.00	0.00	0.00	0.00
Education Fund	1140140001	AG RESALE SUPPLIES	0.00	0.00	0.00	0.00	0.00	0.00	0.00
Education Fund	1140141001	AG SUPPLIES	17,000.00	1,453.11	0.00	1,002.02	10,807.91	5,190.07	30.53
Education Fund	1140141101	AG COMP TECH SUPPLIES	0.00	0.00	0.00	0.00	0.00	0.00	0.00
Education Fund	1140141001	AG SUPPLIES S	0.00	0.00	0.00	0.00	0.00	0.00	0.00
Education Fund	1140141101	AG/COMP TECH SUPPLIES	0.00	0.00	0.00	0.00	0.00	0.00	0.00
Education Fund	1140142001	AG TEXTBOOKS	0.00	0.00	0.00	0.00	0.00	0.00	0.00
Education Fund	1140142001	AG TEXTBOOKS S	0.00	0.00	0.00	0.00	0.00	0.00	0.00

Expenditure Report

Fiscal Year: 2021-2022
Month: March

COUNTY OF GRUNDY SCHOOL DIST 111

Fund Description	Account	Account Description	Revised Budget	MTD Activity	Encumbrance	Pending Activity	Available Funds	Year to Date Activity	Percent of Budget Used
Education Fund	11401430	AG PERIODICALS	0.00	0.00	0.00	0.00	0.00	0.00	0.00
Education Fund	114014302	AG PERIODICALS S	0.00	0.00	0.00	0.00	0.00	0.00	0.00
Education Fund	11401490	AG VIDEO/SOFTWARE	0.00	0.00	0.00	0.00	0.00	0.00	0.00
Education Fund	114014902	AG VIDEO/SOFTWARE S	0.00	0.00	0.00	0.00	0.00	0.00	0.00
Education Fund	1140150001	AG GRANT EQUIPMENT	0.00	0.00	0.00	0.00	0.00	0.00	0.00
Education Fund	1140154001	AG EQUIPMENT	23,352.00	0.00	3,245.00	0.00	20,107.00	0.00	0.00
Education Fund	1140154001	AG EQUIPMENT S	0.00	0.00	0.00	0.00	0.00	0.00	0.00
Education Fund	1140164001	AG DUES/FEES/LIT	3,850.00	0.00	0.00	0.00	3,850.00	0.00	0.00
Education Fund	1140164001	AG DUES/FEES/LIT S	0.00	0.00	0.00	0.00	0.00	0.00	0.00
Education Fund	1140711003	BUSINESS ED SALARY	221,839.92	18,348.66	0.00	0.00	57,982.67	163,857.25	73.86
Education Fund	1140721103	BUSINESS ED TRS	26,627.28	2,202.39	0.00	0.00	6,794.48	19,832.80	71 74.48
Education Fund	1140722203	BUSINESS ED GROUP INS	54,478.80	5,236.84	0.00	0.00	11,451.09	43,027.71	78.98
Education Fund		BUSINESS ED DENTAL INS	1,298.40	111.08	0.00	0.00	314.74	983.66	75.76
Education Fund	1140730003	BUSINESS ED PURCHASE	0.00	0.00	0.00	0.00	0.00	0.00	0.00
Education Fund	1140731003	TREES CETI GRANT	0.00	3,390.00	0.00	0.00	-3,421.81	3,421.81	0.00
Education Fund	1140732303	BUSINESS ED	0.00	0.00	0.00	0.00	0.00	0.00	0.00
Education Fund	1140732303	BUSINESS ED	0.00	0.00	0.00	0.00	0.00	0.00	0.00
Education Fund	1140741003	BUSINESS ED SUPPLIES	3,500.00	1,908.53	0.00	0.00	83.47	3,416.53	97.62
Education Fund	1140741103	BUSINESS ED COMP TECH	0.00	0.00	0.00	0.00	0.00	0.00	0.00
Education Fund	1140741003	BUSINESS ED SUPPLIES S	0.00	0.00	0.00	0.00	0.00	0.00	0.00
Education Fund	1140741103	BUSINESS ED/COMP TECH	0.00	0.00	0.00	0.00	0.00	0.00	0.00
Education Fund	1140742003	BUSINESS ED TEXTBOOKS	0.00	0.00	0.00	0.00	0.00	0.00	0.00
Education Fund	1140742003	BUSINESS ED TEXTBOOKS	0.00	0.00	0.00	0.00	0.00	0.00	0.00
Education Fund	11407430	BUSINESS ED	0.00	0.00	0.00	0.00	0.00	0.00	0.00

Expenditure Report

Fiscal Year: 2021-2022
Month: March

COUNTY OF GRUNDY SCHOOL DIST 111

Fund Description	Account	Account Description	Revised Budget	MTD Activity	Encumbrance	Pending Activity	Available Funds	Year to Date Activity	Percent of Budget Used
Education Fund	114074302	BUSINESS ED	0.00	0.00	0.00	0.00	0.00	0.00	0.00
Education Fund	1140749003	BUSINESS ED	13,275.00	0.00	0.00	0.00	394.00	12,881.00	97.03
Education Fund	1140749003	BUSINESS ED	0.00	0.00	0.00	0.00	0.00	0.00	0.00
Education Fund	1140754003	BUSINESS ED EQUIPMENT	0.00	0.00	0.00	0.00	0.00	0.00	0.00
Education Fund	1140754003	BUSINESS ED EQUIPMENT	0.00	0.00	0.00	0.00	0.00	0.00	0.00
Education Fund	1140764003	BUSINESS ED	315.00	0.00	0.00	0.00	315.00	0.00	0.00
Education Fund	1140764003	BUSINESS ED	0.00	0.00	0.00	0.00	0.00	0.00	0.00
Education Fund	11410110	VIDEO EDIT SALARY	0.00	0.00	0.00	0.00	0.00	0.00	0.00
Education Fund	11410211	VIDEO EDIT TRS	0.00	0.00	0.00	0.00	0.00	0.00	0.00
Education Fund	11410222	VIDEO EDIT GROUP INS	565.00	0.00	0.00	0.00	565.00	0.00	0.00
Education Fund	11410390	VIDEO EDIT PURCHASE	0.00	0.00	0.00	0.00	0.00	0.00	72 0.00
Education Fund	114103902	VIDEO EDIT CONT SERV S	0.00	0.00	0.00	0.00	0.00	0.00	0.00
Education Fund	11410400	VIDEO EDIT RESALE	0.00	0.00	0.00	0.00	0.00	0.00	0.00
Education Fund	11410410	VIDEO EDIT SUPPLIES	500.00	414.45	0.00	0.00	24.43	475.57	95.11
Education Fund	11410411	VIDEO EDIT COMP TECH	0.00	0.00	0.00	0.00	0.00	0.00	0.00
Education Fund	114104102	VIDEO EDIT SUPPLIES S	0.00	0.00	0.00	0.00	0.00	0.00	0.00
Education Fund	114104112	VIDEO EDIT/COMP TECH S	0.00	0.00	0.00	0.00	0.00	0.00	0.00
Education Fund	11410430	VIDEO EDIT PERIODICALS	0.00	0.00	0.00	0.00	0.00	0.00	0.00
Education Fund	114104302	VIDEO EDIT PERIODICALS	0.00	0.00	0.00	0.00	0.00	0.00	0.00
Education Fund	11410490	VIDEO EDIT	0.00	0.00	0.00	0.00	0.00	0.00	0.00
Education Fund	114104902	VIDEO EDIT	0.00	0.00	0.00	0.00	0.00	0.00	0.00
Education Fund	11410540	VIDEO EDIT EQUIPMENT	3,500.00	0.00	3,178.79	0.00	1.29	319.92	9.14
Education Fund	114105402	VIDEO EDIT EQUIPMENT S	0.00	0.00	0.00	0.00	0.00	0.00	0.00
Education Fund	11410640	VIDEO EDIT	0.00	0.00	0.00	0.00	0.00	0.00	0.00

Expenditure Report

Fiscal Year: 2021-2022
Month: March

COUNTY OF GRUNDY SCHOOL DIST 111

Fund Description	Account	Account Description	Revised Budget	MTD Activity	Encumbrance	Pending Activity	Available Funds	Year to Date Activity	Percent of Budget Used
Education Fund	114106402	VIDEO EDIT	0.00	0.00	0.00	0.00	0.00	0.00	0.00
Education Fund	11411110	INST. TECH SALARY	82,477.92	6,873.16	0.00	0.00	20,999.06	61,478.86	74.54
Education Fund	11411211	INST TECH TRS	9,899.52	824.96	0.00	0.00	2,458.51	7,441.01	75.17
Education Fund	11411222	INST TECH INS	27,996.24	2,333.02	0.00	0.00	6,999.06	20,997.18	75.00
Education Fund		INST TEC DENTAL INS	441.60	37.78	0.00	0.00	111.48	330.12	74.76
Education Fund	11411390	INST TECH PUR SERV	0.00	0.00	0.00	0.00	0.00	0.00	0.00
Education Fund	11411410	INST TECH SUPPLIES	0.00	0.00	0.00	0.00	0.00	0.00	0.00
Education Fund	11411540	INST TECH EQUIPMENT	0.00	0.00	0.00	0.00	0.00	0.00	0.00
Education Fund	11417110	ATHLETIC TRAINER	55,582.32	4,631.86	0.00	0.00	13,895.58	41,686.74	75.00
Education Fund	11417221	ATHLETIC TRAINER INS	0.00	0.00	0.00	0.00	0.00	0.00	0.00
Education Fund	10-1417-	ATHLETIC TRAINER	27,996.24	2,333.02	0.00	0.00	6,999.06	20,997.18	73 75.00
Education Fund		ATHLETIC TRAINER	441.60	37.78	0.00	0.00	107.46	334.14	75.67
Education Fund	11417332	ATHLETIC TRAINER	0.00	326.43	0.00	0.00	-326.43	326.43	0.00
Education Fund	11417390	ATHLETIC TRAINER PUR	0.00	0.00	0.00	21,000.00	-42,000.00	21,000.00	0.00
Education Fund	11417410	ATHLETIC TRAINER	603.36	930.48	0.00	0.00	-3,800.40	4,403.76	729.87
Education Fund	11417540	AHTLETIC TRAINER EQUIP	0.00	0.00	0.00	0.00	0.00	0.00	0.00
Education Fund	11417640	ATHLETIC TRAINER	0.00	0.00	0.00	0.00	0.00	0.00	0.00
Education Fund	1142011009	FAM/CONS SCIENCE	201,840.96	16,881.68	0.00	0.00	57,371.75	144,469.21	71.58
Education Fund	1142021109	FAM/CONS SCIENCE TRS	24,226.08	2,026.32	0.00	0.00	6,733.71	17,492.37	72.20
Education Fund	1142022209	FAM/CONS SCIENCE INS	28,200.96	2,350.08	0.00	0.00	7,054.24	21,146.72	74.99
Education Fund		FAM/CONS SCIENCE	883.20	75.56	0.00	0.00	214.92	668.28	75.67
Education Fund	1142032309	FAM/CONS SCIENCE	1,500.00	0.00	0.00	0.00	1,500.00	0.00	0.00
Education Fund	1142032309	FAM/CONS SCI	0.00	0.00	0.00	0.00	0.00	0.00	0.00
Education Fund	1142041009	FAM/CONS SCIENCE	38,000.00	2,527.18	12,570.98	1,687.59	6,935.92	16,805.51	44.23

Expenditure Report

Fiscal Year: 2021-2022
Month: March

COUNTY OF GRUNDY SCHOOL DIST 111

Fund Description	Account	Account Description	Revised Budget	MTD Activity	Encumbrance	Pending Activity	Available Funds	Year to Date Activity	Percent of Budget Used
Education Fund	1142041109	FAM/CONS SCI COMP	0.00	0.00	0.00	0.00	0.00	0.00	0.00
Education Fund	1142041009	FAM/CONS SCI SUPPLIES	0.00	0.00	0.00	0.00	0.00	0.00	0.00
Education Fund	1142041109	FAM/CONS SCI/COMP	0.00	0.00	0.00	0.00	0.00	0.00	0.00
Education Fund	1142042009	FAM/CONS SCIENCE	40,125.00	0.00	0.00	0.00	40,125.00	0.00	0.00
Education Fund	1142042009	FAM/CONS SCI	0.00	0.00	0.00	0.00	0.00	0.00	0.00
Education Fund	1142043009	FAM/CONS SCIENCE	0.00	0.00	0.00	0.00	0.00	0.00	0.00
Education Fund	1142043009	FAM/CONS SCI	0.00	0.00	0.00	0.00	0.00	0.00	0.00
Education Fund	1142049009	FAM/CONS SCI	0.00	0.00	0.00	0.00	0.00	0.00	0.00
Education Fund	1142049009	FAM/CONS SCI	0.00	0.00	0.00	0.00	0.00	0.00	0.00
Education Fund	1142054009	FAM/CONS SCIENCE	0.00	0.00	0.00	0.00	0.00	0.00	0.00
Education Fund	1142054009	FAM/CONS SCI	0.00	0.00	0.00	0.00	0.00	0.00	74 0.00
Education Fund	1142064009	FAM/CONS SCI	625.00	0.00	0.00	0.00	625.00	0.00	0.00
Education Fund	1142064009	FAM/CONS SCI	0.00	0.00	0.00	0.00	0.00	0.00	0.00
Education Fund	11421410	TECH PREP SUPPLIES	0.00	0.00	0.00	0.00	0.00	0.00	0.00
Education Fund	11421490	TECH PREP	0.00	0.00	0.00	0.00	0.00	0.00	0.00
Education Fund	11421540	TECH PREP EQUIPMENT	0.00	0.00	0.00	0.00	0.00	0.00	0.00
Education Fund	1150011030	ATHLETIC DIRECTOR	139,337.04	11,611.42	0.00	0.00	34,834.26	104,502.78	75.00
Education Fund	1150011130	ATHLETIC DIR SECY	50,238.96	4,186.58	0.00	0.00	12,559.74	37,679.22	75.00
Education Fund	1150011230	ASST ATHLETIC DIR	10,007.28	1,107.62	0.00	0.00	407.77	9,599.51	95.93
Education Fund	1150011070	ACTIVITY DIRECTOR	92,190.00	7,682.50	0.00	0.00	23,383.21	68,806.79	74.64
Education Fund	1150011170	ACTIVITY DIR SECY	46,978.56	3,914.88	0.00	0.00	11,744.64	35,233.92	75.00
Education Fund	1150011270	ASST ACTIVITY DIR	15,812.16	1,317.68	0.00	0.00	4,007.39	11,804.77	74.66
Education Fund	1150012170	MAIN OFFICE SECY	0.00	0.00	0.00	0.00	0.00	0.00	0.00
Education Fund	1150012930	WEIGHTROOM	0.00	1,920.00	0.00	0.00	-5,982.00	5,982.00	0.00

Expenditure Report

Fiscal Year: 2021-2022
Month: March

COUNTY OF GRUNDY SCHOOL DIST 111

Fund Description	Account	Account Description	Revised Budget	MTD Activity	Encumbrance	Pending Activity	Available Funds	Year to Date Activity	Percent of Budget Used
Education Fund	1150013030	GIRLS BOWLING COACH	14,287.92	1,190.66	0.00	0.00	3,637.94	10,649.98	74.54
Education Fund	1150013130	EXTRA DUTY COMP-	51,876.72	3,914.52	0.00	0.00	-8,479.55	60,356.27	116.35
Education Fund	1150013230	BOYS GOLF COACH	12,252.48	1,021.04	0.00	0.00	3,104.46	9,148.02	74.66
Education Fund	1150013330	SOFTBALL COACH	16,012.08	1,334.34	0.00	0.00	4,062.34	11,949.74	74.63
Education Fund	1150013430	GIRLS TENNIS COACH	9,415.44	784.62	0.00	0.00	2,395.22	7,020.22	74.56
Education Fund	1150013530	BOYS TRACK COACH	27,877.68	2,596.82	0.00	0.00	5,244.94	22,632.74	81.19
Education Fund	1150013630	GIRLS SOCCER COACH	20,986.80	1,748.90	0.00	0.00	5,725.03	15,261.77	72.72
Education Fund	1150013730	GIRLS VOLLEYBALL	151,128.96	1,677.82	0.00	0.00	124,920.36	26,208.60	17.34
Education Fund	1150013830	CROSS COUNTRY COACH	26,819.52	2,234.96	0.00	0.00	6,754.03	20,065.49	74.82
Education Fund	1150013930	FOOTBALL COACH	240,832.32	4,406.90	0.00	0.00	183,005.07	57,827.25	24.01
Education Fund	1150014030	BASEBALL COACH	84,401.76	3,292.74	0.00	0.00	50,917.95	33,483.81	75 39.67
Education Fund	1150014130	GIRLS BASKETBALL	18,410.16	2,083.74	0.00	0.00	-4,196.74	22,606.90	122.80
Education Fund	1150014230	WRESTLING COACH	19,209.60	3,731.49	0.00	0.00	-14,278.81	33,488.41	174.33
Education Fund	1150014330	BOYS TENNIS COACH	9,415.44	1,335.74	0.00	0.00	1,568.54	7,846.90	83.34
Education Fund	1150014430	BOYS SOCCER COACH	22,443.36	1,870.28	0.00	0.00	5,067.43	17,375.93	77.42
Education Fund	1150014530	CHEERLEADER COACH	116,064.00	0.00	0.00	0.00	92,372.80	23,691.20	20.41
Education Fund	1150014630	POMS COACH	21,424.32	1,964.10	0.00	0.00	4,462.62	16,961.70	79.17
Education Fund	1150014730	BOYS BASKETBALL	30,275.76	2,522.98	0.00	0.00	3,019.43	27,256.33	90.03
Education Fund	1150014830	BOYS BOWLING COACH	6,961.68	580.14	0.00	0.00	-2,227.63	9,189.31	132.00
Education Fund	1150014930	GIRLS GOLF COACH	8,818.80	734.90	0.00	0.00	2,243.72	6,575.08	74.56
Education Fund	1150015030	GIRLS TRACK COACH	24,027.60	2,433.76	0.00	0.00	2,134.37	21,893.23	91.12
Education Fund	1150015130	BOYS VOLLEYBALL	16,961.28	2,204.48	0.00	0.00	-2,177.70	19,138.98	112.84
Education Fund	1150015230	ATHLETIC SCHEDULER	0.00	0.00	0.00	0.00	0.00	0.00	0.00
Education Fund	1150015330	POST SEASON SALARY	9,786.17	0.00	0.00	0.00	9,786.17	0.00	0.00

Expenditure Report

Fiscal Year: 2021-2022
Month: March

COUNTY OF GRUNDY SCHOOL DIST 111

Fund Description	Account	Account Description	Revised Budget	MTD Activity	Encumbrance	Pending Activity	Available Funds	Year to Date Activity	Percent of Budget Used
Education Fund	1150015430	INVITATIONAL WKRS	3,646.62	0.00	0.00	0.00	3,646.62	0.00	0.00
Education Fund	1150015530	BOYS LACROSSE COACH	18,456.94	0.00	0.00	0.00	18,456.94	0.00	0.00
Education Fund	1150015630	GIRLS LACROSSE COACH	11,946.76	382.88	0.00	0.00	9,564.86	2,381.90	19.94
Education Fund	1150012970	STDNT ACT SENIOR	2,886.72	240.56	0.00	0.00	742.92	2,143.80	74.26
Education Fund	1150013070	FALL PLAY/CHLDRNS	0.00	116.44	0.00	0.00	-3,383.98	3,383.98	0.00
Education Fund	1150013170	TECH STDNT ASSOC	6,355.44	529.62	0.00	0.00	1,633.83	4,721.61	74.29
Education Fund	1150013171	EXTRA DUTY COMP-	11,190.00	1,607.81	0.00	1,014.00	-9,197.40	19,373.40	173.13
Education Fund	1150013270	SCHOLASTIC BOWL	4,892.40	407.70	0.00	0.00	1,244.40	3,648.00	74.56
Education Fund	1150013370	SPEECH SPONSOR	12,071.52	1,005.96	0.00	0.00	3,075.22	8,996.30	74.52
Education Fund	1150013470	INTL CLUB SPONSOR	4,818.00	401.50	0.00	0.00	1,204.50	3,613.50	75.00
Education Fund	1150013570	INTL THESPIANS	0.00	0.00	0.00	0.00	0.00	0.00	76 0.00
Education Fund	1150013670	INDIANS ON THE AIR	2,339.76	194.98	0.00	0.00	601.56	1,738.20	74.29
Education Fund	1150013770	BAND ACTIVITIES	20,126.88	1,677.24	0.00	0.00	5,032.08	15,094.80	75.00
Education Fund	1150013870	CHOIR ACTIVITIES	9,880.08	823.34	0.00	0.00	2,535.03	7,345.05	74.34
Education Fund	1150013970	NHS SPONSOR	12,688.80	1,057.40	0.00	0.00	3,234.29	9,454.51	74.51
Education Fund	1150014070	YEARBOOK SPONSOR	5,375.28	447.94	0.00	0.00	1,376.26	3,999.02	74.40
Education Fund	1150014170	SENIOR CLASS SPONSOR	8,043.60	670.30	0.00	0.00	2,045.73	5,997.87	74.57
Education Fund	1150014270	FBLA SPONSOR	0.00	0.00	0.00	0.00	0.00	0.00	0.00
Education Fund	1150014370	STUDENT COUNCIL	13,371.36	1,114.28	0.00	0.00	3,560.28	9,811.08	73.37
Education Fund	1150014470	SOPH CLASS SPONSOR	2,095.92	174.66	0.00	0.00	523.90	1,572.02	75.00
Education Fund	1150014570	MUSICAL	3,144.00	262.00	0.00	0.00	786.00	2,358.00	75.00
Education Fund	1150014670	WYSE SPONSOR	2,305.44	192.12	0.00	0.00	576.20	1,729.24	75.01
Education Fund	1150014770	ENVIRONMENTAL CLUB	0.00	0.00	0.00	0.00	0.00	0.00	0.00
Education Fund	1150014870	JSA SPONSOR	0.00	0.00	0.00	0.00	0.00	0.00	0.00

Expenditure Report

Fiscal Year: 2021-2022
Month: March

COUNTY OF GRUNDY SCHOOL DIST 111

Fund Description	Account	Account Description	Revised Budget	MTD Activity	Encumbrance	Pending Activity	Available Funds	Year to Date Activity	Percent of Budget Used
Education Fund	1150014970	JUNIOR CLASS SPONSOR	7,280.16	606.68	0.00	0.00	1,820.16	5,460.00	75.00
Education Fund	1150015070	FRESHMAN CLASS	2,095.92	174.66	0.00	0.00	523.90	1,572.02	75.00
Education Fund	1150015170	SADD/TATU SPONSOR	3,379.92	281.66	0.00	0.00	422.33	2,957.59	87.50
Education Fund	1150015270	WEB SITE SPONSOR	0.00	0.00	0.00	0.00	0.00	0.00	0.00
Education Fund	1150015370	ART CLUB SPONSOR	2,207.52	183.96	0.00	0.00	573.12	1,634.40	74.04
Education Fund	1150015470	FFA SPONSOR	11,161.68	930.14	0.00	0.00	2,849.28	8,312.40	74.47
Education Fund	1150015570	MATH CLUB SPONSOR	5,351.52	445.96	0.00	0.00	1,359.12	3,992.40	74.60
Education Fund	1150015670	FLAG	0.00	174.66	0.00	0.00	-7,549.95	7,549.95	0.00
Education Fund	1150015770	FRENCH NHS SPONSOR	0.00	0.00	0.00	0.00	-212.25	212.25	0.00
Education Fund	1150015870	LITERARY MAGAZINE	2,934.48	244.54	0.00	0.00	759.76	2,174.72	74.11
Education Fund	1150015970	SPANISH NHS SPONSOR	2,886.72	240.56	0.00	0.00	742.92	2,143.80	77 74.26
Education Fund	1150016070	NEWSPAPER SPONSOR	6,027.84	502.32	0.00	0.00	1,528.12	4,499.72	74.65
Education Fund	1150016170	INVESTMENT CLUB	2,886.72	240.56	0.00	0.00	742.92	2,143.80	74.26
Education Fund	1150016270	PIT ORCHESTRA	0.00	0.00	0.00	0.00	-262.07	262.07	0.00
Education Fund	1150016370	MUSICAL VOCAL	3,982.32	331.86	0.00	0.00	1,021.77	2,960.55	74.34
Education Fund	1150016470	TECH DIRECTOR	2,724.72	227.06	0.00	0.00	678.84	2,045.88	75.09
Education Fund	1150016570	PERCUSSION	0.00	0.00	0.00	0.00	-1,698.00	1,698.00	0.00
Education Fund	1150016670	ODESSEY BOOK CLUB	1,698.00	141.50	0.00	0.00	424.50	1,273.50	75.00
Education Fund	1150016770	MADRIGAL SPONSOR	0.00	0.00	0.00	0.00	-1,698.00	1,698.00	0.00
Education Fund	1150016870	HOPE SPONSOR	0.00	0.00	0.00	0.00	0.00	0.00	0.00
Education Fund	1150016970	MARK SPONSOR	0.00	0.00	0.00	0.00	0.00	0.00	0.00
Education Fund	1150017070	IALC SPONSOR	2,037.60	169.80	0.00	0.00	509.40	1,528.20	75.00
Education Fund	1150017170	INTERACT CLUB SPONSOR	4,558.08	379.84	0.00	0.00	1,351.83	3,206.25	70.34
Education Fund	1150017270	STUDENT ACTIVITIES	0.00	0.00	0.00	0.00	0.00	0.00	0.00

Expenditure Report

Fiscal Year: 2021-2022
Month: March

COUNTY OF GRUNDY SCHOOL DIST 111

Fund Description	Account	Account Description	Revised Budget	MTD Activity	Encumbrance	Pending Activity	Available Funds	Year to Date Activity	Percent of Budget Used
Education Fund	1150017370	MADRIGAL HELPERS	0.00	0.00	0.00	0.00	0.00	0.00	0.00
Education Fund	1150017470	MAC SPONSOR	5,221.20	435.10	0.00	0.00	-482.15	5,703.35	109.23
Education Fund	1150017570	CLIMBING CLUB SPONSOR	2,037.60	169.80	0.00	0.00	509.40	1,528.20	75.00
Education Fund	1150017670	INDOOR PERCUSSION	0.00	0.00	0.00	0.00	0.00	0.00	0.00
Education Fund	1150017770	ORCHESIS SPONSOR	4,932.24	411.02	0.00	0.00	1,469.34	3,462.90	70.21
Education Fund	1150017870	CHESS CLUB SPONSOR	2,305.68	192.14	0.00	0.00	576.48	1,729.20	75.00
Education Fund	1150017970	SUMMER CAMP COACHES	5,000.00	0.00	0.00	0.00	8,642.49	-3,642.49	-72.85
Education Fund	1150018070	JAZZ TRANSIT CHOIR	1,900.00	0.00	0.00	0.00	1,900.00	0.00	0.00
Education Fund	1150018170	UNDERWATER ROV	2,515.20	209.60	0.00	0.00	628.80	1,886.40	75.00
Education Fund	1150018270	PAC LIGHT/SOUND	0.00	0.00	0.00	0.00	-2,860.00	2,860.00	0.00
Education Fund		YMCA TEEN ACHIEVERS	0.00	187.50	0.00	0.00	-656.25	656.25	78 0.00
Education Fund	10-1500-211	INVITATIONAL WORKERS	0.00	0.00	0.00	0.00	0.00	0.00	0.00
Education Fund	10-1500-	ASST ATHLETIC DIR	0.00	0.00	0.00	0.00	0.00	0.00	0.00
Education Fund	1150021130	ATHLETIC TRS	17,072.88	1,653.91	0.00	0.00	3,548.52	13,524.36	79.22
Education Fund	1150021230	ASST ATHLETIC DIRECTOR	1,715.04	142.94	0.00	0.00	425.92	1,289.12	75.17
Education Fund		ATH/ACT	4,710.48	289.97	0.00	0.00	-175.47	4,885.95	103.73
Education Fund		ATH/ACT	1,470.48	122.57	0.00	0.00	363.18	1,107.30	75.30
Education Fund		ATH/ACT	1,921.92	160.14	0.00	0.00	475.50	1,446.42	75.26
Education Fund		ATH/ACT	1,130.40	94.20	0.00	0.00	280.54	849.86	75.18
Education Fund		ATH/ACT	3,346.32	311.78	0.00	0.00	605.45	2,740.87	81.91
Education Fund		ATH/ACT	2,518.56	209.89	0.00	0.00	673.62	1,844.94	73.25
Education Fund		ATH/ACT	18,139.44	201.36	0.00	0.00	14,978.63	3,160.81	17.43
Education Fund		ATH/ACT	3,219.60	268.31	0.00	0.00	790.28	2,429.32	75.45
Education Fund		ATH/ACT	6,361.44	530.10	0.00	0.00	1,247.80	5,113.64	80.38

Expenditure Report

Fiscal Year: 2021-2022
Month: March

COUNTY OF GRUNDY SCHOOL DIST 111

Fund Description	Account	Account Description	Revised Budget	MTD Activity	Encumbrance	Pending Activity	Available Funds	Year to Date Activity	Percent of Budget Used
Education Fund		ATH/ACT	3,882.24	396.31	0.00	0.00	347.58	3,534.66	91.05
Education Fund		ATH/ACT	2,228.16	185.72	0.00	0.00	-183.35	2,411.51	108.23
Education Fund		ATH/ACT	2,305.92	192.15	0.00	0.00	354.18	1,951.74	84.64
Education Fund		ATH/ACT	1,130.16	160.34	0.00	0.00	181.21	948.95	83.97
Education Fund		ATH/ACT	2,076.96	173.08	0.00	0.00	511.92	1,565.04	75.35
Education Fund		ATH/ACT	2,571.36	235.81	0.00	0.00	518.59	2,052.77	79.83
Education Fund		ATH/ACT	3,633.84	302.84	0.00	0.00	969.48	2,664.36	73.32
Education Fund		ATH/ACT	835.68	69.66	0.00	0.00	203.47	632.21	75.65
Education Fund		ATH/ACT	1,058.88	88.20	0.00	0.00	262.94	795.94	75.17
Education Fund		ATH/ACT	2,884.32	292.12	0.00	0.00	231.04	2,653.28	91.99
Education Fund		ATH/ACT	2,035.68	264.56	0.00	0.00	289.88	1,745.80	79 85.76
Education Fund	1150021171	EXTRA-CURRICULAR TRS	11,642.40	970.20	0.00	0.00	2,879.65	8,762.75	75.27
Education Fund	1150021270	ACTIVITIES TRS	0.00	13.97	0.00	0.00	-406.05	406.05	0.00
Education Fund		ATH/ACT	2,660.40	221.75	0.00	0.00	660.17	2,000.23	75.19
Education Fund		ATH/ACT	794.88	127.46	0.00	0.00	-673.57	1,468.45	184.74
Education Fund		ATH/ACT	586.80	48.91	0.00	0.00	145.36	441.44	75.23
Education Fund		ATH/ACT	1,449.12	120.76	0.00	0.00	360.20	1,088.92	75.14
Education Fund		ATH/ACT	374.40	31.21	0.00	0.00	91.13	283.27	75.66
Education Fund		ATH/ACT	280.80	23.40	0.00	0.00	70.47	210.33	74.90
Education Fund		ATH/ACT	2,416.56	201.34	0.00	0.00	588.63	1,827.93	75.64
Education Fund		ATH/ACT	1,185.60	98.80	0.00	0.00	296.88	888.72	74.96
Education Fund		ATH/ACT	1,545.12	128.76	0.00	0.00	384.14	1,160.98	75.14
Education Fund		ATH/ACT	645.36	53.79	0.00	0.00	161.23	484.13	75.02
Education Fund		ATH/ACT	978.00	81.50	0.00	0.00	242.60	735.40	75.19

Expenditure Report

Fiscal Year: 2021-2022
Month: March

COUNTY OF GRUNDY SCHOOL DIST 111

Fund Description	Account	Account Description	Revised Budget	MTD Activity	Encumbrance	Pending Activity	Available Funds	Year to Date Activity	Percent of Budget Used
Education Fund		ATH/ACT	1,604.88	133.75	0.00	0.00	418.22	1,186.66	73.94
Education Fund		ATH/ACT	251.52	20.96	0.00	0.00	61.17	190.35	75.68
Education Fund		ATH/ACT	377.28	31.44	0.00	0.00	91.87	285.41	75.65
Education Fund		ATH/ACT	276.72	23.06	0.00	0.00	67.35	209.37	75.66
Education Fund		ATH/ACT	874.08	72.84	0.00	0.00	212.90	661.18	75.64
Education Fund		ATH/ACT	251.52	20.97	0.00	0.00	61.15	190.37	75.69
Education Fund		ATH/ACT	405.60	33.79	0.00	0.00	45.43	360.17	88.80
Education Fund		ATH/ACT	265.20	22.10	0.00	0.00	67.29	197.91	74.63
Education Fund		ATH/ACT	1,339.92	111.66	0.00	0.00	333.75	1,006.17	75.09
Education Fund		ATH/ACT	642.72	53.54	0.00	0.00	159.31	483.41	75.21
Education Fund		10 E 1500 2110 70 300	0.00	20.98	0.00	0.00	-157.38	157.38	80 0.00
Education Fund		ATH/ACT	0.00	0.00	0.00	0.00	-26.82	26.82	0.00
Education Fund		ATH/ACT	352.08	29.34	0.00	0.00	89.00	263.08	74.72
Education Fund		ATH/ACT	346.80	28.89	0.00	0.00	87.22	259.58	74.85
Education Fund		ATH/ACT	723.36	60.28	0.00	0.00	178.78	544.58	75.28
Education Fund		ATH/ACT	346.80	28.88	0.00	0.00	87.17	259.63	74.86
Education Fund		ATH/ACT	0.00	0.00	0.00	0.00	-33.10	33.10	0.00
Education Fund		ATH/ACT	478.56	39.88	0.00	0.00	119.91	358.65	74.94
Education Fund		ATH/ACT	327.12	27.26	0.00	0.00	79.38	247.74	75.73
Education Fund		ATH/ACT	203.76	16.98	0.00	0.00	49.60	154.16	75.66
Education Fund		ATH/ACT	244.80	20.40	0.00	0.00	59.64	185.16	75.64
Education Fund		ATH/ACT	547.68	45.64	0.00	0.00	160.35	387.33	70.72
Education Fund		ATH/ACT	626.88	52.24	0.00	0.00	152.64	474.24	75.65
Education Fund		ATH/ACT	244.32	20.36	0.00	0.00	59.31	185.01	75.72

Expenditure Report

Fiscal Year: 2021-2022
Month: March

COUNTY OF GRUNDY SCHOOL DIST 111

Fund Description	Account	Account Description	Revised Budget	MTD Activity	Encumbrance	Pending Activity	Available Funds	Year to Date Activity	Percent of Budget Used
Education Fund		ATH/ACT	0.00	0.00	0.00	0.00	0.00	0.00	0.00
Education Fund		ATH/ACT	251.76	20.98	0.00	0.00	61.33	190.43	75.64
Education Fund		ATH/ACT	276.72	23.06	0.00	0.00	67.38	209.34	75.65
Education Fund		ATH/ACT	0.00	0.00	0.00	0.00	-2,838.38	2,838.38	0.00
Education Fund		ATH/ACT	301.68	25.16	0.00	0.00	73.42	228.26	75.66
Education Fund		10 E 1500 2110 70 300	0.00	22.51	0.00	0.00	-78.81	78.81	0.00
Education Fund	10-1500-	ATHLETIC DIRECTOR	0.00	0.00	0.00	0.00	0.00	0.00	0.00
Education Fund	10-1500-	ACTIVITY DIRECTOR	0.00	0.00	0.00	0.00	0.00	0.00	0.00
Education Fund	10-1500-222	INVITATIONAL WKRS	0.00	0.00	0.00	0.00	0.00	0.00	0.00
Education Fund	11500222	MAIN OFFICE INS	0.00	0.00	0.00	0.00	0.00	0.00	0.00
Education Fund	10-1500-	ASST ATHLETIC DIR	0.00	0.00	0.00	0.00	0.00	0.00	81 0.00
Education Fund	1150022230	ATHLETIC DIR/SECY	28,207.44	2,350.62	0.00	0.00	7,051.86	21,155.58	75.00
Education Fund		ATH/ACT	18,169.92	1,514.16	0.00	0.00	4,542.48	13,627.44	75.00
Education Fund		ATH/ACT	1,670.40	203.46	0.00	0.00	73.04	1,597.36	95.63
Education Fund		ATH/ACT	0.00	0.00	0.00	0.00	0.00	0.00	0.00
Education Fund		ATH/ACT	0.00	0.00	0.00	0.00	0.00	0.00	0.00
Education Fund		10 E 1500 2220 30 300	0.00	0.00	0.00	0.00	-0.07	0.07	0.00
Education Fund		ATH/ACT	0.00	0.00	0.00	0.00	-220.23	220.23	0.00
Education Fund		ATH/ACT	0.00	0.00	0.00	0.00	-54.17	54.17	0.00
Education Fund	1150022270	STUDENT ACT/SECY	198.00	16.50	0.00	0.00	49.74	148.26	74.88
Education Fund		ATH/ACT	27,996.24	2,333.02	0.00	0.00	6,999.06	20,997.18	75.00
Education Fund		ATH/ACT	1,958.16	0.00	0.00	0.00	970.41	987.75	50.44
Education Fund		10 E 1500 2220 70 300	0.00	0.00	0.00	0.00	-743.73	743.73	0.00
Education Fund		10 E 1500 2220 70 300	0.00	174.75	0.00	0.00	-1,139.43	1,139.43	0.00

Expenditure Report

Fiscal Year: 2021-2022
Month: March

COUNTY OF GRUNDY SCHOOL DIST 111

Fund Description	Account	Account Description	Revised Budget	MTD Activity	Encumbrance	Pending Activity	Available Funds	Year to Date Activity	Percent of Budget Used
Education Fund		10 E 1500 2220 70 300	0.00	0.00	0.00	0.00	-82.52	82.52	0.00
Education Fund		10 E 1500 2220 70 300	0.00	0.00	0.00	0.00	-212.03	212.03	0.00
Education Fund		ATH/ACT	0.00	0.00	0.00	0.00	-0.44	0.44	0.00
Education Fund		ATH/ACT	1,408.56	120.54	0.00	0.00	342.66	1,065.90	75.67
Education Fund		ATH/ACT	441.60	37.78	0.00	0.00	107.46	334.14	75.67
Education Fund		ATH/ACT	26.40	3.36	0.00	0.00	-4.69	31.09	117.77
Education Fund		ATH/ACT	441.60	37.78	0.00	0.00	107.46	334.14	75.67
Education Fund		ATH/ACT	441.60	37.78	0.00	0.00	107.46	334.14	75.67
Education Fund		10 E 1500 2230 70 300	0.00	0.00	0.00	0.00	-15.50	15.50	0.00
Education Fund		10 E 1500 2230 70 300	0.00	0.00	0.00	0.00	-4.28	4.28	0.00
Education Fund	1150030030	GIRLS TRACK PUR SERV	0.00	0.00	0.00	0.00	0.00	0.00	82 0.00
Education Fund	1150030130	BOYS SOCCER PUR SERV	0.00	0.00	0.00	0.00	-422.00	422.00	0.00
Education Fund	1150030230	BOYS BASKETBALL PUR	0.00	0.00	0.00	0.00	0.00	0.00	0.00
Education Fund	1150030330	WRESTLING PUR SERV	0.00	0.00	0.00	0.00	0.00	0.00	0.00
Education Fund	1150030430	BOYS VOLLEYBALL PUR	0.00	0.00	0.00	0.00	0.00	0.00	0.00
Education Fund	1150030530	SOFTBALL PUR SERV	0.00	0.00	0.00	0.00	0.00	0.00	0.00
Education Fund	1150030630	CHEERLEADER PUR SERV	0.00	0.00	0.00	0.00	0.00	0.00	0.00
Education Fund	1150030730	GIRLS VOLLEYBALL PUR	0.00	0.00	0.00	0.00	0.00	0.00	0.00
Education Fund	1150030830	GIRLS BOWLING PUR	2,200.00	8,335.75	0.00	0.00	-6,135.75	8,335.75	378.90
Education Fund	1150030930	GOLF PURCHASE SERV	2,000.00	0.00	0.00	0.00	2,000.00	0.00	0.00
Education Fund	1150031030	CROSS COUNTRY PUR	0.00	0.00	0.00	0.00	0.00	0.00	0.00
Education Fund	1150031130	GIRLS BASKETBALL PUR	0.00	0.00	0.00	0.00	0.00	0.00	0.00
Education Fund	1150031230	BASEBALL PUR SERV	8,000.00	2,702.00	3,733.08	0.00	1,564.92	2,702.00	33.78
Education Fund	1150031330	GIRLS TENNIS PUR SERV	0.00	0.00	0.00	0.00	0.00	0.00	0.00

Expenditure Report

Fiscal Year: 2021-2022
Month: March

COUNTY OF GRUNDY SCHOOL DIST 111

Fund Description	Account	Account Description	Revised Budget	MTD Activity	Encumbrance	Pending Activity	Available Funds	Year to Date Activity	Percent of Budget Used
Education Fund	1150031430	POMS PUR SERV	0.00	0.00	0.00	0.00	-6,512.31	6,512.31	0.00
Education Fund	1150031530	FOOTBALL PUR SERV	25,000.00	0.00	2,536.08	0.00	1,950.29	20,513.63	82.05
Education Fund	1150031630	BOYS TRACK PUR SERV	0.00	0.00	0.00	0.00	-250.00	250.00	0.00
Education Fund	1150031730	GIRLS SOCCER PUR SERV	0.00	0.00	0.00	0.00	0.00	0.00	0.00
Education Fund	1150032130	GEN ATHLETIC PUR SERV	0.00	0.00	0.00	0.00	0.00	0.00	0.00
Education Fund	1150033330	SUMMER BASEBALL PUR	0.00	0.00	0.00	0.00	0.00	0.00	0.00
Education Fund	1150033630	ATH TRAINER PUR SERV	0.00	0.00	0.00	0.00	0.00	0.00	0.00
Education Fund	1150033730	BOYS BOWLING PUR SERV	4,000.00	8,534.25	0.00	0.00	-4,534.25	8,534.25	213.36
Education Fund	1150039330	BOYS TENNIS PUR SERV	0.00	0.00	0.00	0.00	0.00	0.00	0.00
Education Fund	1150039530	SWIMMING PUR SERVICE	30,414.00	0.00	0.00	0.00	30,414.00	0.00	0.00
Education Fund	1150031170	INVESTMENT CLUB	0.00	0.00	0.00	0.00	0.00	0.00	83 0.00
Education Fund	1150031270	SADD/TATU RED RIBBON	0.00	0.00	0.00	0.00	0.00	0.00	0.00
Education Fund	1150031370	THESPIAN THEATRE FEST	0.00	0.00	0.00	0.00	0.00	0.00	0.00
Education Fund	1150031470	CHAPERONE FOR	0.00	0.00	0.00	0.00	0.00	0.00	0.00
Education Fund	1150031570	ICTM MATH TEAM	0.00	0.00	0.00	0.00	0.00	0.00	0.00
Education Fund	1150031770	TSA STATE	0.00	0.00	0.00	0.00	0.00	0.00	0.00
Education Fund	1150031870	JOURNALISM IHSA	0.00	0.00	0.00	0.00	0.00	0.00	0.00
Education Fund	1150032170	FFA	0.00	0.00	0.00	0.00	0.00	0.00	0.00
Education Fund	1150030070	MUSICAL PUR SERV	11,000.00	2,882.00	0.00	0.00	4,713.00	6,287.00	57.15
Education Fund	1150030170	FALL PLAY PUR SERV	3,000.00	0.00	0.00	0.00	1,755.68	1,244.32	41.48
Education Fund	1150030270	STUDENT ACT PUR SERV	2,500.00	0.00	0.00	0.00	2,065.01	434.99	17.40
Education Fund	1150030370	NEWSPAPER PUR SERV	5,000.00	631.00	0.00	0.00	2,635.00	2,365.00	47.30
Education Fund	1150030470	CHILDRENS THEATRE PUR	1,500.00	0.00	0.00	0.00	1,500.00	0.00	0.00
Education Fund	1150030570	INTL CLUB PUR SERV	0.00	0.00	0.00	0.00	0.00	0.00	0.00

Expenditure Report

Fiscal Year: 2021-2022
Month: March

COUNTY OF GRUNDY SCHOOL DIST 111

Fund Description	Account	Account Description	Revised Budget	MTD Activity	Encumbrance	Pending Activity	Available Funds	Year to Date Activity	Percent of Budget Used
Education Fund	1150030670	WINTERGUARD PUR SERV	2,000.00	0.00	500.00	0.00	250.00	1,250.00	62.50
Education Fund	1150030770	NHS PUR SERV	0.00	0.00	0.00	0.00	0.00	0.00	0.00
Education Fund	1150030870	FFA PUR SERV	0.00	0.00	0.00	0.00	0.00	0.00	0.00
Education Fund	1150030970	STUDENT ORGANIZATION	0.00	0.00	0.00	0.00	0.00	0.00	0.00
Education Fund	1150031070	BOOK CLUB SPEAKER	250.00	0.00	0.00	0.00	250.00	0.00	0.00
Education Fund	1150031670	MINOOKA ANGLERS	1,200.00	0.00	0.00	0.00	937.84	262.16	21.85
Education Fund	1150032070	FBLA	0.00	0.00	0.00	0.00	0.00	0.00	0.00
Education Fund	1150032270	FOOTBALL CLEANUP	1,200.00	0.00	0.00	0.00	0.00	1,200.00	100.00
Education Fund	1150032370	REVTRAK ACTIVITY	75,000.00	7,281.65	0.00	0.00	37,479.31	37,520.69	50.03
Education Fund	1150031930	GIRLS VOLLEYBALL	2,822.40	0.00	0.00	0.00	-424.60	3,247.00	115.04
Education Fund	1150032030	BOYS SOCCER OFFICIAL	3,614.10	0.00	0.00	0.00	505.10	3,109.00	84 86.02
Education Fund	1150032230	SOFTBALL OFFICIAL	0.00	0.00	195.00	0.00	-242.10	47.10	0.00
Education Fund	1150032330	FOOTBALL OFFICIAL	5,217.45	0.00	0.00	0.00	71.45	5,146.00	98.63
Education Fund	1150032430	BOYS BASKETBALL	6,805.05	745.00	544.00	0.00	725.05	5,536.00	81.35
Education Fund	1150032530	GIRLS BASKETBALL	4,625.25	678.00	173.00	0.00	-73.75	4,526.00	97.85
Education Fund	1150032630	WRESTLING OFFICIAL	2,710.05	139.00	0.00	0.00	1,525.05	1,185.00	43.73
Education Fund	1150032730	BASEBALL OFFICIALS	756.00	0.00	868.00	0.00	-279.50	167.50	22.16
Education Fund	1150032830	CROSS COUNTRY	449.40	0.00	0.00	0.00	-264.60	714.00	158.88
Education Fund	1150032930	BOYS VOLLEYBALL	81.90	0.00	308.00	0.00	-226.10	0.00	0.00
Education Fund	1150033030	GIRLS TRACK OFFICIAL	0.00	0.00	0.00	0.00	0.00	0.00	0.00
Education Fund	1150033130	BOYS TRACK OFFICIAL	0.00	0.00	450.00	0.00	-500.00	50.00	0.00
Education Fund	1150033230	GIRLS SOCCER OFFICIAL	192.15	0.00	505.00	0.00	-312.85	0.00	0.00
Education Fund	1150033830	INVITATIONAL OFFICIALS	304.50	0.00	0.00	0.00	304.50	0.00	0.00
Education Fund	1150033930	LACROSSE OFFICIALS	0.00	0.00	588.00	0.00	-850.88	262.88	0.00

Expenditure Report

Fiscal Year: 2021-2022
Month: March

COUNTY OF GRUNDY SCHOOL DIST 111

Fund Description	Account	Account Description	Revised Budget	MTD Activity	Encumbrance	Pending Activity	Available Funds	Year to Date Activity	Percent of Budget Used
Education Fund	1150031970	STUDENT ACT	1,443.75	0.00	0.00	0.00	763.75	680.00	47.10
Education Fund	1150031830	ATHLETIC TOWEL	0.00	0.00	0.00	0.00	0.00	0.00	0.00
Education Fund	1150033430	GENERAL ATHLETIC	0.00	0.00	0.00	0.00	0.00	0.00	0.00
Education Fund	1150033530	ATHLETIC DIRECTOR	175.00	0.00	0.00	0.00	175.00	0.00	0.00
Education Fund	1150033270	STUDENT ACT/TRAVEL	3,390.91	3,035.78	0.00	0.00	-1,351.27	4,742.18	139.85
Education Fund	1150033570	ACTIVITY DIRECTOR	408.39	83.46	0.00	0.00	-6.53	414.92	101.60
Education Fund	1150039030	GEN ATHLETIC	20,000.00	-250.00	4,830.00	0.00	-9,121.00	24,291.00	121.46
Education Fund	1150039430	GEN ATHLETIC POST	30,000.00	16,315.99	0.00	0.00	-20,437.37	50,437.37	168.12
Education Fund	1150139030	GATE RECEIPTS CASH	0.00	0.00	0.00	0.00	0.00	0.00	0.00
Education Fund	1150041030	WRESTLING SUPPLIES	6,500.00	0.00	0.00	0.00	-44.01	6,544.01	100.68
Education Fund	1150041130	GIRLS TENNIS SUPPLIES	1,000.00	0.00	996.00	0.00	4.00	0.00	85 0.00
Education Fund	1150041230	BOYS TENNIS SUPPLIES	1,000.00	996.00	0.00	0.00	-992.00	1,992.00	199.20
Education Fund	1150041330	CROSS COUNTRY	1,500.00	0.00	0.00	0.00	1,500.00	0.00	0.00
Education Fund	1150041430	CHEERLEADER SUPPLIES	2,000.00	0.00	0.00	0.00	1,600.00	400.00	20.00
Education Fund	1150041530	BOYS GOLF SUPPLIES	4,500.00	0.00	0.00	0.00	5.86	4,494.14	99.87
Education Fund	1150041630	BOYS TRACK SUPPLIES	1,700.00	0.00	1,551.54	0.00	148.46	0.00	0.00
Education Fund	1150041730	GIRLS TRACK SUPPLIES	2,000.00	0.00	1,105.00	0.00	895.00	0.00	0.00
Education Fund	1150041830	GEN ATHLETIC SUPPLIES	4,500.00	0.00	0.00	0.00	35.75	4,464.25	99.21
Education Fund	1150041930	GIRLS SOCCER SUPPLIES	3,300.00	0.00	3,266.00	0.00	34.00	0.00	0.00
Education Fund	1150042030	BASEBALL SUPPLIES	4,500.00	1,730.00	2,264.32	0.00	505.68	1,730.00	38.44
Education Fund	1150042130	SOFTBALL SUPPLIES	4,500.00	0.00	0.00	0.00	2,581.00	1,919.00	42.64
Education Fund	1150042230	BOYS VOLLEYBALL	2,000.00	0.00	0.00	0.00	-158.73	2,158.73	107.94
Education Fund	1150042330	GIRLS VOLLEYBALL	4,000.00	0.00	0.00	0.00	-5.72	4,005.72	100.14
Education Fund	1150042430	GIRLS BASKETBALL	1,400.00	0.00	650.00	0.00	382.00	368.00	26.29

Expenditure Report

Fiscal Year: 2021-2022
Month: March

COUNTY OF GRUNDY SCHOOL DIST 111

Fund Description	Account	Account Description	Revised Budget	MTD Activity	Encumbrance	Pending Activity	Available Funds	Year to Date Activity	Percent of Budget Used
Education Fund	1150042530	BOYS SOCCER SUPPLIES	1,750.00	0.00	720.00	0.00	-262.34	1,292.34	73.85
Education Fund	1150042630	BOYS BASKETBALL	1,350.00	0.00	0.00	0.00	109.17	1,240.83	91.91
Education Fund	1150042730	ATHLETIC DIRECTOR	5,500.00	433.00	1,137.18	0.00	1,801.51	2,561.31	46.57
Education Fund	1150042830	FOOTBALL SUPPLIES	42,000.00	0.00	14,289.24	0.00	-13,918.22	41,628.98	99.12
Education Fund	1150042930	GIRLS BOWLING SUPPLIES	200.00	0.00	0.00	0.00	200.00	0.00	0.00
Education Fund	1150043030	POMS SUPPLIES	3,600.00	0.00	324.00	0.00	-849.60	4,125.60	114.60
Education Fund	1150043130	ATHLETIC AWARD	22,500.00	153.00	3,883.75	0.00	5,153.23	13,463.02	59.84
Education Fund	1150043230	GIRLS GOLF SUPPLIES	3,700.00	0.00	0.00	0.00	800.41	2,899.59	78.37
Education Fund	1150043330	SUMMER BASEBALL	1,400.00	0.00	0.00	0.00	1,400.00	0.00	0.00
Education Fund	1150043430	BOYS BOWLING SUPPLIES	200.00	0.00	0.00	0.00	200.00	0.00	0.00
Education Fund	1150043530	ATHLETIC COMP TECH	0.00	0.00	0.00	0.00	0.00	0.00	86 0.00
Education Fund	1150043630	LACROSSE SUPPLIES	7,545.00	960.00	6,585.00	0.00	0.00	960.00	12.72
Education Fund	1150044030	BOYS GOLF UNIFORMS	0.00	0.00	0.00	0.00	0.00	0.00	0.00
Education Fund	1150044130	GIRLS GOLF UNIFORMS	0.00	0.00	0.00	0.00	0.00	0.00	0.00
Education Fund	1150044230	GIRLS TENNIS UNIFORMS	0.00	0.00	0.00	0.00	0.00	0.00	0.00
Education Fund	1150044330	BOYS BOWLING	0.00	0.00	0.00	0.00	0.00	0.00	0.00
Education Fund	1150044430	GIRLS BOWLING	0.00	0.00	0.00	0.00	0.00	0.00	0.00
Education Fund	1150044530	WRESTLING UNIFORMS	1,800.00	0.00	0.00	0.00	1,800.00	0.00	0.00
Education Fund	1150044630	BOYS TRACK UNIFORMS	1,800.00	0.00	0.00	0.00	206.40	1,593.60	88.53
Education Fund	1150044730	GIRLS TRACK UNIFORMS	1,555.00	1,112.10	0.00	0.00	442.90	1,112.10	71.52
Education Fund	1150044830	BOYS TENNIS UNIFORMS	0.00	0.00	0.00	0.00	0.00	0.00	0.00
Education Fund	1150044930	BASEBALL UNIFORMS	4,400.00	0.00	2,445.12	0.00	-1,258.81	3,213.69	73.04
Education Fund	1150045030	SOFTBALL UNIFORMS	0.00	0.00	0.00	0.00	0.00	0.00	0.00
Education Fund	1150045130	GIRLS BASKETBALL	2,700.00	0.00	0.00	0.00	-49.00	2,749.00	101.81

Expenditure Report

Fiscal Year: 2021-2022
Month: March

COUNTY OF GRUNDY SCHOOL DIST 111

Fund Description	Account	Account Description	Revised Budget	MTD Activity	Encumbrance	Pending Activity	Available Funds	Year to Date Activity	Percent of Budget Used
Education Fund	1150045230	BOYS SOCCER UNIFORMS	2,500.00	0.00	0.00	0.00	2,500.00	0.00	0.00
Education Fund	1150045330	GIRLS VOLLEYBALL	2,500.00	0.00	0.00	0.00	315.00	2,185.00	87.40
Education Fund	1150045430	CROSS COUNTRY	4,500.00	0.00	0.00	0.00	2,691.70	1,808.30	40.18
Education Fund	1150045530	POMS UNIFORMS	5,500.00	0.00	0.00	0.00	5,500.00	0.00	0.00
Education Fund	1150045630	BOYS BASKETBALL	4,000.00	0.00	0.00	0.00	-1,168.75	5,168.75	129.22
Education Fund	1150045730	BOYS VOLLEYBALL	2,500.00	0.00	0.00	0.00	2,500.00	0.00	0.00
Education Fund	1150045830	GIRLS SOCCER UNIFORMS	2,500.00	0.00	2,472.60	0.00	27.40	0.00	0.00
Education Fund	1150045930	FOOTBALL UNIFORMS	0.00	0.00	0.00	0.00	0.00	0.00	0.00
Education Fund	1150046030	CHEERLEADING	5,000.00	0.00	0.00	0.00	0.00	5,000.00	100.00
Education Fund	1150046130	LACROSSE UNIFORMS	4,000.00	0.00	0.00	0.00	4,000.00	0.00	0.00
Education Fund	1150141030	ATHLETIC TRAINER	0.00	0.00	0.00	0.00	0.00	0.00	87 0.00
Education Fund	1150042770	INTERNATIONAL CLUB	0.00	0.00	0.00	0.00	0.00	0.00	0.00
Education Fund	1150042970	YEARBOOK SUPPLIES	0.00	0.00	0.00	0.00	0.00	0.00	0.00
Education Fund	1150043270	WEBSITE	0.00	0.00	0.00	0.00	0.00	0.00	0.00
Education Fund	1150043570	INVESTMENT CLUB	0.00	0.00	0.00	0.00	0.00	0.00	0.00
Education Fund	1150041070	NEWSPAPER SUPPLIES	100.00	0.00	0.00	0.00	100.00	0.00	0.00
Education Fund	1150041170	SPEECH SUPPLIES	100.00	91.29	0.00	0.00	8.71	91.29	91.29
Education Fund	1150041270	KALEIDOSCOPE SUPPLIES	100.00	0.00	0.00	0.00	4.63	95.37	95.37
Education Fund	1150041370	NHS SUPPLIES	1,500.00	0.00	0.00	0.00	954.97	545.03	36.34
Education Fund	1150041470	MUSICAL SUPPLIES	5,000.00	1,656.52	0.00	322.48	439.95	4,237.57	84.75
Education Fund	1150041570	FALL PLAY SUPPLIES	1,400.00	0.00	0.00	0.00	-68.01	1,468.01	104.86
Education Fund	1150041670	STUDENT ACT SUPPLIES	1,800.00	30.00	330.00	0.00	82.16	1,387.84	77.10
Education Fund	1150041770	ACTIVITY OFFICE	500.00	0.00	0.00	0.00	61.87	438.13	87.63
Education Fund	1150041870	CHILDRENS THEATRE	1,000.00	0.00	396.00	0.00	604.00	0.00	0.00

Expenditure Report

Fiscal Year: 2021-2022
Month: March

COUNTY OF GRUNDY SCHOOL DIST 111

Fund Description	Account	Account Description	Revised Budget	MTD Activity	Encumbrance	Pending Activity	Available Funds	Year to Date Activity	Percent of Budget Used
Education Fund	1150041970	INTL CLUB SUPPLIES	0.00	0.00	0.00	0.00	0.00	0.00	0.00
Education Fund	1150042070	WINTERGUARD SUPPLIES	5,000.00	555.00	0.00	0.00	2,273.17	2,726.83	54.54
Education Fund	1150042170	BOOK CLUB AWARDS	100.00	0.00	0.00	0.00	100.00	0.00	0.00
Education Fund	1150042270	FBLA SUPPLIES	0.00	0.00	0.00	0.00	0.00	0.00	0.00
Education Fund	1150042370	FNHS INDUCTION	100.00	0.00	0.00	0.00	100.00	0.00	0.00
Education Fund	1150042470	INVESTMENT CLUB	100.00	0.00	0.00	0.00	100.00	0.00	0.00
Education Fund	1150042570	SPANISH NHS INDUCTION	100.00	0.00	0.00	0.00	100.00	0.00	0.00
Education Fund	1150042670	SADD/TATU SUPPLIES	100.00	0.00	0.00	0.00	100.00	0.00	0.00
Education Fund	1150042870	SCHOLASTIC BOWL	100.00	0.00	0.00	0.00	100.00	0.00	0.00
Education Fund	1150043170	MADRIGAL SUPPLIES	0.00	0.00	0.00	0.00	0.00	0.00	0.00
Education Fund	1150043370	SENIOR MURAL	250.00	0.00	0.00	0.00	250.00	0.00	88 0.00
Education Fund	1150043470	COLOR PAPER SUPPLIES	400.00	0.00	0.00	0.00	400.00	0.00	0.00
Education Fund	1150043670	ACTIVITY P-CARD ORDERS	3,000.00	0.00	0.00	0.00	2,799.97	200.03	6.67
Education Fund	1150043770	INTL THESPIAN SUPPLIES	500.00	0.00	0.00	0.00	371.00	129.00	25.80
Education Fund	1150043870	CHESS TEAM SUPPLIES	100.00	0.00	0.00	0.00	100.00	0.00	0.00
Education Fund	1150043970	PAC SOUND ROOM	500.00	11,633.38	0.00	0.00	-15,701.98	16,201.98	3,240.40
Education Fund	1150043070	STUDENT ACT	0.00	0.00	0.00	0.00	0.00	0.00	0.00
Education Fund	1150049070	STUDENT ACT	0.00	0.00	0.00	0.00	0.00	0.00	0.00
Education Fund	1150054030	GIRLS TRACK EQUIPMENT	0.00	0.00	0.00	0.00	0.00	0.00	0.00
Education Fund	1150054130	BOYS TENNIS EQUIPMENT	0.00	0.00	0.00	0.00	0.00	0.00	0.00
Education Fund	1150054230	FOOTBALL EQUIPMENT	0.00	0.00	0.00	0.00	0.00	0.00	0.00
Education Fund	1150054330	GIRLS TENNIS EQUIPMENT	0.00	0.00	0.00	0.00	0.00	0.00	0.00
Education Fund	1150054430	BOYS TRACK EQUIPMENT	0.00	0.00	0.00	0.00	0.00	0.00	0.00
Education Fund	1150054530	GENERAL ATHLETIC	20,000.00	0.00	0.00	0.00	1,717.02	18,282.98	91.41

Expenditure Report

Fiscal Year: 2021-2022
Month: March

COUNTY OF GRUNDY SCHOOL DIST 111

Fund Description	Account	Account Description	Revised Budget	MTD Activity	Encumbrance	Pending Activity	Available Funds	Year to Date Activity	Percent of Budget Used
Education Fund	1150054630	BASEBALL EQUIPMENT	0.00	0.00	0.00	0.00	0.00	0.00	0.00
Education Fund	1150054730	BOYS GOLF EQUIPMENT	0.00	0.00	0.00	0.00	0.00	0.00	0.00
Education Fund	1150054830	GIRLS VOLLEYBALL	0.00	0.00	0.00	0.00	0.00	0.00	0.00
Education Fund	1150054930	BOYS VOLLEYBALL	0.00	0.00	0.00	0.00	0.00	0.00	0.00
Education Fund	1150055030	BOYS BASKETBALL	0.00	0.00	0.00	0.00	0.00	0.00	0.00
Education Fund	1150055130	SOFTBALL EQUIPMENT	0.00	0.00	0.00	0.00	0.00	0.00	0.00
Education Fund	1150055230	WRESTLING EQUIPMENT	0.00	0.00	0.00	0.00	0.00	0.00	0.00
Education Fund	1150055330	GIRLS BASKETBALL	0.00	0.00	0.00	0.00	0.00	0.00	0.00
Education Fund	1150055430	CROSS COUNTRY	0.00	0.00	0.00	0.00	0.00	0.00	0.00
Education Fund	1150055530	GIRLS BOWLING	0.00	0.00	0.00	0.00	0.00	0.00	0.00
Education Fund	1150055630	BOYS SOCCER	0.00	0.00	0.00	0.00	0.00	0.00	89 0.00
Education Fund	1150055730	ATHLETIC DIRECTOR	0.00	0.00	0.00	0.00	0.00	0.00	0.00
Education Fund	1150055830	GIRLS SOCCER	0.00	0.00	0.00	0.00	0.00	0.00	0.00
Education Fund	1150055930	POMS EQUIPMENT	0.00	0.00	0.00	0.00	0.00	0.00	0.00
Education Fund	1150056030	GIRLS GOLF EQUIPMENT	0.00	0.00	0.00	0.00	0.00	0.00	0.00
Education Fund	1150056130	CHEERLEADER	0.00	0.00	0.00	0.00	0.00	0.00	0.00
Education Fund	1150056230	BOYS BOWLING	0.00	0.00	0.00	0.00	0.00	0.00	0.00
Education Fund	1150056330	SUMMER BASEBALL	0.00	0.00	0.00	0.00	0.00	0.00	0.00
Education Fund	1150056430	LACROSSE EQUIPMENT	5,000.00	0.00	0.00	0.00	5,000.00	0.00	0.00
Education Fund	1150154030	ATHLETIC TRAINER	0.00	0.00	0.00	0.00	0.00	0.00	0.00
Education Fund	1150054070	STUDENT ACT EQUIPMENT	0.00	0.00	0.00	0.00	0.00	0.00	0.00
Education Fund	1150054170	MAIN OFFICE EQUIPMENT	0.00	0.00	0.00	0.00	0.00	0.00	0.00
Education Fund	1150054270	WINTERGUARD	0.00	0.00	0.00	0.00	0.00	0.00	0.00
Education Fund	1150054370	PAC SOUND ROOM	5,000.00	0.00	0.00	0.00	4,330.76	669.24	13.38

Expenditure Report

Fiscal Year: 2021-2022
Month: March

COUNTY OF GRUNDY SCHOOL DIST 111

Fund Description	Account	Account Description	Revised Budget	MTD Activity	Encumbrance	Pending Activity	Available Funds	Year to Date Activity	Percent of Budget Used
Education Fund	1150039130	GEN ATHLETIC CLINICS	5,500.00	0.00	0.00	0.00	4,415.14	1,084.86	19.72
Education Fund	1150039230	ATHLETIC DIRECTOR	500.00	0.00	0.00	0.00	294.00	206.00	41.20
Education Fund	1150064030	ATHLETIC DUES/FEES	200.00	0.00	0.00	0.00	-4,744.00	4,944.00	2,472.00
Education Fund	1150064570	TSA FEES	0.00	0.00	0.00	0.00	0.00	0.00	0.00
Education Fund	1150064970	FNHS DUES	0.00	0.00	0.00	0.00	0.00	0.00	0.00
Education Fund	1150065070	SADD/TUTA REG/TRAINING	0.00	0.00	0.00	0.00	0.00	0.00	0.00
Education Fund	1150039070	SPEECH ENTRY FEES	1,000.00	0.00	0.00	0.00	152.00	848.00	84.80
Education Fund	1150064070	SPEECH DUES/FEES	0.00	0.00	0.00	0.00	0.00	0.00	0.00
Education Fund	1150064170	STUDENT ACT	0.00	0.00	0.00	0.00	0.00	0.00	0.00
Education Fund	1150064270	ICTM REGIONAL/ORAL	300.00	0.00	0.00	0.00	0.00	300.00	100.00
Education Fund	1150064370	WYSE REGISTRATION	300.00	0.00	0.00	0.00	220.00	80.00	90 26.67
Education Fund	1150064470	FBLA COMPETITION FEES	0.00	0.00	0.00	0.00	0.00	0.00	0.00
Education Fund	1150064670	SPANISH NHS	100.00	0.00	0.00	0.00	100.00	0.00	0.00
Education Fund	1150064770	JOURNALISM FEES/STATE	250.00	0.00	0.00	0.00	250.00	0.00	0.00
Education Fund	1150064870	FFA	0.00	0.00	0.00	0.00	0.00	0.00	0.00
Education Fund	1150065170	WINTERGUARD CIRCUIT	2,100.00	0.00	0.00	0.00	-800.00	2,900.00	138.10
Education Fund	1150065270	INDOOR PERCUSSION	1,500.00	0.00	0.00	0.00	610.00	890.00	59.33
Education Fund	11600110	SUMMER SCHOOL SALARY	0.00	0.00	0.00	0.00	0.00	0.00	0.00
Education Fund	11600211	SUMMER SCHOOL TRS	0.00	0.00	0.00	0.00	0.00	0.00	0.00
Education Fund	10-1600-	SUMMER SCHOOL SALARY	0.00	0.00	0.00	0.00	0.00	0.00	0.00
Education Fund	11650390	GIFTED PUR SERV	0.00	0.00	0.00	0.00	0.00	0.00	0.00
Education Fund	11650410	GIFTED SUPPLIES	0.00	0.00	0.00	0.00	0.00	0.00	0.00
Education Fund	11650540	GIFTED EQUIPMENT	0.00	0.00	0.00	0.00	0.00	0.00	0.00
Education Fund	11700110	DRIVER ED SALARY	414,650.00	35,975.68	0.00	0.00	92,941.08	321,708.92	77.59

Expenditure Report

Fiscal Year: 2021-2022
Month: March

COUNTY OF GRUNDY SCHOOL DIST 111

Fund Description	Account	Account Description	Revised Budget	MTD Activity	Encumbrance	Pending Activity	Available Funds	Year to Date Activity	Percent of Budget Used
Education Fund	11700111	SUMMER DR ED SALARY	22,066.00	0.00	0.00	0.00	22,066.00	0.00	0.00
Education Fund	11700211	SUMMER DR ED TRS	2,787.00	0.00	0.00	0.00	2,787.00	0.00	0.00
Education Fund	1170021121	DRIVER ED TRS	52,355.00	4,318.10	0.00	0.00	13,404.70	38,950.30	74.40
Education Fund	11700222	DR ED INS	5,239.82	0.00	0.00	0.00	5,239.82	0.00	0.00
Education Fund	10-1700-	DRIVER ED SALARY	84,463.26	7,491.04	0.00	0.00	22,122.90	62,340.36	73.81
Education Fund		DRIVER ED DENTAL INS	0.00	226.68	0.00	0.00	-2,004.84	2,004.84	0.00
Education Fund	1170030021	DRIVERS ED CONT SERV	0.00	0.00	0.00	0.00	0.00	0.00	0.00
Education Fund	1170030021	DRIVERS ED CONT SERV S	0.00	0.00	0.00	0.00	0.00	0.00	0.00
Education Fund	11700323	DRIVERS ED	0.00	0.00	0.00	0.00	0.00	0.00	0.00
Education Fund	1170038021	DRIVER ED CAR INS	0.00	0.00	0.00	0.00	0.00	0.00	0.00
Education Fund	1170041021	DRIVERS ED SUPPLIES	2,018.00	0.00	0.00	0.00	-588.13	2,606.13	9129.14
Education Fund	1170041021	DRIVERS ED SUPPLIES S	0.00	0.00	0.00	0.00	0.00	0.00	0.00
Education Fund	1170041121	DR ED COMP TECH	0.00	0.00	0.00	0.00	0.00	0.00	0.00
Education Fund	1170042021	DRIVERS ED TEXTBOOKS	1,673.00	0.00	0.00	0.00	1,673.00	0.00	0.00
Education Fund	1170042021	DRIVERS ED TEXTBOOKS	0.00	0.00	0.00	0.00	0.00	0.00	0.00
Education Fund	11700464	DR ED GAS	7,700.00	597.29	0.00	399.71	2,129.99	5,170.30	67.15
Education Fund	1170049021	DRIVERS ED	0.00	0.00	0.00	0.00	0.00	0.00	0.00
Education Fund	1170049021	DRIVERS ED	0.00	0.00	0.00	0.00	0.00	0.00	0.00
Education Fund	1170054021	DRIVERS ED EQUIPMENT	0.00	0.00	0.00	0.00	0.00	0.00	0.00
Education Fund	1170054021	DRIVERS ED EQUIPMENT	0.00	0.00	0.00	0.00	0.00	0.00	0.00
Education Fund	1170055021	DRIVERS ED VEHICLES	25,000.00	0.00	0.00	0.00	25,000.00	0.00	0.00
Education Fund	1170064021	DRIVERS ED	0.00	0.00	0.00	0.00	0.00	0.00	0.00
Education Fund	1170064021	DRIVERS ED	0.00	0.00	0.00	0.00	0.00	0.00	0.00
Education Fund	11800110	ELL INSTRUCTION	0.00	0.00	0.00	0.00	0.00	0.00	0.00

Expenditure Report

Fiscal Year: 2021-2022
Month: March

COUNTY OF GRUNDY SCHOOL DIST 111

Fund Description	Account	Account Description	Revised Budget	MTD Activity	Encumbrance	Pending Activity	Available Funds	Year to Date Activity	Percent of Budget Used
Education Fund	11800211	ELL TRS	0.00	0.00	0.00	0.00	0.00	0.00	0.00
Education Fund	11900110	PROJ IND DIR SALARY	102,781.20	8,565.10	0.00	0.00	26,035.78	76,745.42	74.67
Education Fund	11900112	PROJ INDIAN AIDE	33,126.96	2,317.70	0.00	0.00	8,793.92	24,333.04	73.45
Education Fund	11900211	PROJ IND TRS	12,336.72	1,028.05	0.00	0.00	3,015.16	9,321.56	75.56
Education Fund	11900222	PROJ IND GROUP INS	27,996.24	2,333.02	0.00	0.00	6,999.06	20,997.18	75.00
Education Fund		PROJ INDIAN AIDE INS	18,169.92	1,514.16	0.00	0.00	4,542.48	13,627.44	75.00
Education Fund		PROJ INDIAN DENTAL INS	441.60	37.78	0.00	0.00	107.46	334.14	75.67
Education Fund	11900390	PROJ IND PUR SERV	0.00	0.00	0.00	0.00	0.00	0.00	0.00
Education Fund	11900332	PROJ IND WORKSHOPS	0.00	0.00	0.00	0.00	0.00	0.00	0.00
Education Fund	11900410	PROJ IND SUPPLIES	0.00	0.00	0.00	0.00	0.00	0.00	0.00
Education Fund	11900411	PROJ IND COMP TECH	0.00	0.00	0.00	0.00	0.00	0.00	92 0.00
Education Fund	11900420	PROJ IND TEXTBOOKS	0.00	0.00	0.00	0.00	0.00	0.00	0.00
Education Fund	11900540	PROJ IND EQUIPMENT	0.00	0.00	0.00	0.00	0.00	0.00	0.00
Education Fund	11900640	PROJ IND DUES/FEES/LIT	0.00	0.00	0.00	0.00	0.00	0.00	0.00
Education Fund	11912670	SPECIAL EDUCATION	1,898,981.00	117,066.42	0.00	77,553.18	680,031.23	1,141,396.59	60.11
Education Fund	12100112	ASST PRIN-LEARNING	0.00	0.00	0.00	0.00	0.00	0.00	0.00
Education Fund	12100113	MAIN OFFICE SECY	37,442.64	2,824.37	0.00	0.00	11,757.91	25,684.73	68.60
Education Fund	12100110	DIRECTOR STUDENT	129,424.32	10,785.36	0.00	0.00	32,356.08	97,068.24	75.00
Education Fund	12100111	DIR OF STUDENT SERV	0.00	0.00	0.00	0.00	0.00	0.00	0.00
Education Fund	12100120	SUMMER MAIN OFFICE	0.00	0.00	0.00	0.00	0.00	0.00	0.00
Education Fund	12100211	DIR OF STUDENT SERV	0.00	0.00	0.00	0.00	0.00	0.00	0.00
Education Fund	121002111	ASST PRIN-LEARNING TRS	0.00	0.00	0.00	0.00	0.00	0.00	0.00
Education Fund	10-2100-	DIRECTOR STUDENT	15,858.00	1,321.50	0.00	0.00	3,964.50	11,893.50	75.00
Education Fund	10-2100-	DIRECTOR STUDENT	0.00	0.00	0.00	0.00	0.00	0.00	0.00

Expenditure Report

Fiscal Year: 2021-2022
Month: March

COUNTY OF GRUNDY SCHOOL DIST 111

Fund Description	Account	Account Description	Revised Budget	MTD Activity	Encumbrance	Pending Activity	Available Funds	Year to Date Activity	Percent of Budget Used
Education Fund	12100222	MAIN OFFICE GROUP INS	0.00	0.00	0.00	0.00	0.00	0.00	0.00
Education Fund		10 E 2100 2220 00 300	0.00	2,203.96	0.00	0.00	-6,611.88	6,611.88	0.00
Education Fund	12100223	DIRECTOR STUDENT	96.00	8.00	0.00	0.00	24.00	72.00	75.00
Education Fund	12100300	MAIN OFFICE PUR SERV	0.00	0.00	0.00	0.00	0.00	0.00	0.00
Education Fund	12100390	DIRECTOR STUDENT SERV	3,000.00	0.00	0.00	0.00	2,968.68	31.32	1.04
Education Fund	12100400	DIRECTOR STUDENT SERV	500.00	0.00	0.00	0.00	402.29	97.71	19.54
Education Fund	12100410	MAIN OFFICE SUPPLIES	250.00	0.00	0.00	0.00	250.00	0.00	0.00
Education Fund	12100540	MAIN OFFICE EQUIPMENT	0.00	0.00	0.00	0.00	0.00	0.00	0.00
Education Fund	12100640	CLINICS/WORKSHOPS	0.00	0.00	0.00	0.00	0.00	0.00	0.00
Education Fund	12100641	PROFESSIONAL DUES	0.00	0.00	0.00	0.00	0.00	0.00	0.00
Education Fund	12100642	DIR STUDENT SER	400.00	0.00	0.00	0.00	236.40	163.60	93 40.90
Education Fund	12100643	DIR STUDENT SERV	750.00	0.00	0.00	0.00	750.00	0.00	0.00
Education Fund			0.00	0.00	0.00	0.00	0.00	0.00	0.00
Education Fund	12110100	TITLE 1 SALARIES	41,178.47	1,635.56	0.00	0.00	23,772.88	17,405.59	42.27
Education Fund	10-2110-211	TITLE 1 SALARIES (IC)	4,298.10	364.96	0.00	0.00	1,003.12	3,294.98	76.66
Education Fund	10-2110-222	TITLE 1 SALARIES (BMF 2)	11,021.97	903.76	0.00	0.00	2,854.36	8,167.61	74.10
Education Fund		TITLE I DENTAL INS	90.88	15.40	0.00	0.00	-45.89	136.77	150.50
Education Fund	12113110	SOCIAL WORKER SALARY	260,179.20	18,814.44	0.00	0.00	94,645.67	165,533.53	63.62
Education Fund	12113211	SOCIAL WORKER TRS	31,229.52	2,258.29	0.00	0.00	11,165.16	20,064.36	64.25
Education Fund	12113222	SOCIAL WORKERS GROUP	52,323.36	4,360.28	0.00	0.00	13,114.61	39,208.75	74.94
Education Fund		SOCIAL WORKER DENTAL	1,144.80	97.94	0.00	0.00	279.15	865.65	75.62
Education Fund	12113390	SOCIAL WORKER PUR	0.00	0.00	0.00	0.00	0.00	0.00	0.00
Education Fund	121133902	SOCIAL WOKER CONT	0.00	0.00	0.00	0.00	0.00	0.00	0.00
Education Fund	12113332	SOCIAL WORKER	0.00	0.00	0.00	0.00	0.00	0.00	0.00

Expenditure Report

Fiscal Year: 2021-2022
Month: March

COUNTY OF GRUNDY SCHOOL DIST 111

Fund Description	Account	Account Description	Revised Budget	MTD Activity	Encumbrance	Pending Activity	Available Funds	Year to Date Activity	Percent of Budget Used
Education Fund	121133322	SOCIAL WORKER	0.00	0.00	0.00	0.00	0.00	0.00	0.00
Education Fund	12113410	SOCIAL WORKER	500.00	0.00	0.00	0.00	500.00	0.00	0.00
Education Fund	12113411	SOCIAL WKR COMP TECH	0.00	0.00	0.00	0.00	0.00	0.00	0.00
Education Fund	12113414	SOCIAL WORKER TESTING	1,500.00	0.00	0.00	0.00	1,500.00	0.00	0.00
Education Fund	121134102	SOCIAL WORKER	0.00	0.00	0.00	0.00	0.00	0.00	0.00
Education Fund	121134112	SOC WKR COMP TECK	0.00	0.00	0.00	0.00	0.00	0.00	0.00
Education Fund	121134142	SOCIAL WORKER TESTING	0.00	0.00	0.00	0.00	0.00	0.00	0.00
Education Fund	12113490	SOC WORKER	0.00	0.00	0.00	0.00	0.00	0.00	0.00
Education Fund	121134902	SOCIAL WORKER	0.00	0.00	0.00	0.00	0.00	0.00	0.00
Education Fund	12113640	SOC WORKER	0.00	0.00	0.00	0.00	0.00	0.00	0.00
Education Fund	121136402	SOCIAL WORKER	0.00	0.00	0.00	0.00	0.00	0.00	94 0.00
Education Fund	12120110	GUIDANCE SALARY	585,206.40	43,016.08	0.00	0.00	187,253.66	397,952.74	68.00
Education Fund		ESSER III - GUIDANCE	0.00	5,528.41	0.00	0.00	-27,982.09	27,982.09	0.00
Education Fund	12120211	GUIDANCE TRS	70,242.00	5,163.14	0.00	0.00	22,112.21	48,129.79	68.52
Education Fund		10 E 2120 2110 00 300	0.00	1,233.52	0.00	0.00	-6,243.54	6,243.54	0.00
Education Fund	12120222	GUIDANCE GROUP INS	116,458.08	9,704.84	0.00	0.00	29,114.52	87,343.56	75.00
Education Fund		10 E 2120 2220 00 300	0.00	710.00	0.00	0.00	-2,830.94	2,830.94	0.00
Education Fund		GUIDANCE DENTAL INS	2,649.60	226.68	0.00	0.00	644.76	2,004.84	75.67
Education Fund		10 E 2120 2230 00 300	0.00	37.78	0.00	0.00	-150.14	150.14	0.00
Education Fund	12120314	GUIDANCE PUR SERV	1,600.00	0.00	0.00	0.00	1,500.00	100.00	6.25
Education Fund	12120415	A.P. TESTING SERVICES	0.00	0.00	0.00	0.00	0.00	0.00	0.00
Education Fund	121203142	GUIDANCE CONT SERV S	0.00	0.00	0.00	0.00	0.00	0.00	0.00
Education Fund	121204152	A.P. TESTING SERVICES S	0.00	0.00	0.00	0.00	0.00	0.00	0.00
Education Fund	12120411	GUIDANCE COMP TECH	0.00	0.00	0.00	0.00	0.00	0.00	0.00

Expenditure Report

Fiscal Year: 2021-2022
Month: March

COUNTY OF GRUNDY SCHOOL DIST 111

Fund Description	Account	Account Description	Revised Budget	MTD Activity	Encumbrance	Pending Activity	Available Funds	Year to Date Activity	Percent of Budget Used
Education Fund	12120412	GUIDANCE SUPPLIES	500.00	0.00	0.00	0.00	-69.73	569.73	113.95
Education Fund	12120414	GUIDANCE TESTING	500.00	-286.00	0.00	0.00	786.00	-286.00	-57.20
Education Fund	1212041030	ALC SUPPLIES & S/W	0.00	0.00	0.00	0.00	0.00	0.00	0.00
Education Fund	121204112	GUIDANCE COMP TECH	0.00	0.00	0.00	0.00	0.00	0.00	0.00
Education Fund	121204122	GUIDANCE SUPPLIES S	200.00	0.00	0.00	0.00	-30.88	230.88	115.44
Education Fund	121204142	GUIDANCE TESTING S	0.00	0.00	0.00	0.00	0.00	0.00	0.00
Education Fund	12120420	GUIDANCE REF BOOKS	0.00	0.00	0.00	0.00	0.00	0.00	0.00
Education Fund	121204202	GUIDANCE REFERENCE	0.00	0.00	0.00	0.00	0.00	0.00	0.00
Education Fund	12120540	GUIDANCE EQUIPMENT	0.00	0.00	0.00	0.00	0.00	0.00	0.00
Education Fund	121205402	GUIDANCE EQUIPMENT S	0.00	0.00	0.00	0.00	0.00	0.00	0.00
Education Fund	12120640	GUIDANCE DUES	0.00	0.00	0.00	0.00	0.00	0.00	95 0.00
Education Fund	12120641	GUIDANCE	0.00	0.00	0.00	0.00	0.00	0.00	0.00
Education Fund	121206402	GUIDANCE DUES/FEES/LIT	0.00	0.00	0.00	0.00	0.00	0.00	0.00
Education Fund	121206412	GUIDANCE	0.00	0.00	0.00	0.00	0.00	0.00	0.00
Education Fund	12125110	REGISTRAR SALARY	51,512.40	3,666.66	0.00	0.00	15,492.24	36,020.16	69.93
Education Fund	12125111	ACADEMIC RESOURCE	47,229.60	3,591.20	0.00	0.00	12,999.60	34,230.00	72.48
Education Fund	12125112	ASST. REGISTRAR	34,860.00	2,697.50	0.00	0.00	9,428.80	25,431.20	72.95
Education Fund	12125211	CAREER CENTER TRS	0.00	0.00	0.00	0.00	0.00	0.00	0.00
Education Fund	12125222	REGISTRAR GROUP INS	26,604.24	2,217.02	0.00	0.00	6,651.06	19,953.18	75.00
Education Fund	12125223	CAREER CTR GROUP INS	8,363.28	696.94	0.00	0.00	2,435.29	5,927.99	70.88
Education Fund	10-2125-	ASST. REGISTRAR (BMF)	48.00	4.00	0.00	0.00	12.12	35.88	74.75
Education Fund		REGISTRAR DENTAL INS	441.60	37.78	0.00	0.00	107.46	334.14	75.67
Education Fund		ASST. REGISTRAR DENTAL	0.00	0.00	0.00	0.00	0.00	0.00	0.00
Education Fund	12125300	REGISTRAR PUR SERV	0.00	0.00	0.00	0.00	0.00	0.00	0.00

Expenditure Report

Fiscal Year: 2021-2022
Month: March

COUNTY OF GRUNDY SCHOOL DIST 111

Fund Description	Account	Account Description	Revised Budget	MTD Activity	Encumbrance	Pending Activity	Available Funds	Year to Date Activity	Percent of Budget Used
Education Fund	12125390	CAREER CTR PUR SERV	0.00	0.00	0.00	0.00	0.00	0.00	0.00
Education Fund	121253002	REGISTRAR CONT SERV S	7,850.50	0.00	0.00	0.00	5,858.14	1,992.36	25.38
Education Fund	121253902	CAREER CTR CONT SERV	0.00	0.00	0.00	0.00	0.00	0.00	0.00
Education Fund	12125323	CAREER CTR	0.00	0.00	0.00	0.00	0.00	0.00	0.00
Education Fund	12125324	REGISTRAR REPAIR/MAINT	0.00	0.00	0.00	0.00	0.00	0.00	0.00
Education Fund	121253232	CAREER CTR	0.00	0.00	0.00	0.00	0.00	0.00	0.00
Education Fund	121253242	REGISTRAR REPAIR/MAINT	0.00	0.00	0.00	0.00	0.00	0.00	0.00
Education Fund	12125410	CAREER CENTER	0.00	0.00	0.00	0.00	0.00	0.00	0.00
Education Fund	121254101	CAREER CENTER COMP	0.00	0.00	0.00	0.00	0.00	0.00	0.00
Education Fund	12125411	REGISTRAR SUPPLIES	1,500.00	47.76	0.00	0.00	804.82	695.18	46.35
Education Fund	12125412	REGISTRAR COMP TECH	0.00	0.00	0.00	0.00	0.00	0.00	96 0.00
Education Fund	121254102	CAREER CTR SUPPLIES S	0.00	0.00	0.00	0.00	0.00	0.00	0.00
Education Fund	121254112	REGISTRAR SUPPLIES S	0.00	0.00	0.00	0.00	0.00	0.00	0.00
Education Fund	121254122	REGISTRAR COMP TECH	0.00	0.00	0.00	0.00	0.00	0.00	0.00
Education Fund	12125540	CAREER CTR EQUIPMENT	0.00	0.00	0.00	0.00	0.00	0.00	0.00
Education Fund	12125541	REGISTRAR EQUIPMENT	0.00	0.00	0.00	0.00	0.00	0.00	0.00
Education Fund	121255402	CAREER CTR EQUIPMENT	0.00	0.00	0.00	0.00	0.00	0.00	0.00
Education Fund	121255412	REGISTRAR EQUIPMENT S	0.00	0.00	0.00	0.00	0.00	0.00	0.00
Education Fund	12134110	NURSE SALARY	67,846.32	4,954.94	0.00	0.00	30,776.23	37,070.09	54.64
Education Fund	12134111	NURSE SALARY S.C.	35,537.04	5,227.50	0.00	0.00	2,925.30	32,611.74	91.77
Education Fund	12134211	NURSE TRS	0.00	0.00	0.00	0.00	0.00	0.00	0.00
Education Fund	10-2134-	NURSE SALARY S.C. (IC)	0.00	0.00	0.00	0.00	0.00	0.00	0.00
Education Fund	12134222	NURSE GROUP INS	54.72	6.56	0.00	0.00	15.42	39.30	71.82
Education Fund	10-2134-	NURSE SALARY S.C.	45.60	5.80	0.00	0.00	5.55	40.05	87.83

Expenditure Report

Fiscal Year: 2021-2022
Month: March

COUNTY OF GRUNDY SCHOOL DIST 111

Fund Description	Account	Account Description	Revised Budget	MTD Activity	Encumbrance	Pending Activity	Available Funds	Year to Date Activity	Percent of Budget Used
Education Fund	12134300	NURSE PUR SERV	0.00	0.00	0.00	0.00	0.00	0.00	0.00
Education Fund	121343002	NURSE CONT SERV S	0.00	0.00	0.00	0.00	0.00	0.00	0.00
Education Fund	12134323	NURSE REPAIR/MAINT	0.00	0.00	0.00	0.00	-30.00	30.00	0.00
Education Fund	121343232	NURSE REPAIR/MAINT S	0.00	0.00	0.00	0.00	-30.00	30.00	0.00
Education Fund	12134410	NURSE SUPPLIES	8,000.00	16.46	1,694.78	339.98	4,041.07	1,924.17	24.05
Education Fund	12134411	NURSES SUPPLIES-BBP	0.00	0.00	0.00	0.00	0.00	0.00	0.00
Education Fund	12134412	NURSE COMP TECH	0.00	0.00	0.00	0.00	0.00	0.00	0.00
Education Fund	121344102	NURSE SUPPLIES S	0.00	0.00	0.00	0.00	0.00	0.00	0.00
Education Fund	121344112	NURSES SUPPLIES-BBP S	0.00	0.00	0.00	0.00	0.00	0.00	0.00
Education Fund	121344122	NURSE COMP TECH	0.00	0.00	0.00	0.00	0.00	0.00	0.00
Education Fund	12134420	RN REFERENCE BOOKS	0.00	0.00	0.00	0.00	0.00	0.00	97 0.00
Education Fund	121344202	NURSE REFERENCE	0.00	0.00	0.00	0.00	0.00	0.00	0.00
Education Fund	12134540	NURSE EQUIPMENT	0.00	0.00	0.00	0.00	0.00	0.00	0.00
Education Fund	121345402	NURSE EQUIPMENT S	0.00	0.00	0.00	0.00	0.00	0.00	0.00
Education Fund	12140110	PSYCHOLOGIST SALARY	193,590.48	12,327.66	0.00	0.00	78,569.78	115,020.70	59.41
Education Fund	10-2140-211	PSYCHOLOGIST SALARY	23,236.56	1,479.66	0.00	0.00	9,319.77	13,916.79	59.89
Education Fund	12140222	PSYCHOLOGIST	96.00	8.00	0.00	0.00	24.00	72.00	75.00
Education Fund	12140400	PSYCHOLOGIST SUPPLIES	0.00	0.00	0.00	0.00	0.00	0.00	0.00
Education Fund	12142300	PSYCHOLOGICAL	0.00	0.00	0.00	0.00	0.00	0.00	0.00
Education Fund	10-2190-	CSBO SALARY (BIMRF)	0.00	0.00	0.00	0.00	0.00	0.00	0.00
Education Fund		TITLE II SALARIES	0.00	0.00	0.00	0.00	-1,144.00	1,144.00	0.00
Education Fund	12210110	DIRECTOR C/I SALARY	123,763.68	10,313.64	0.00	0.00	19,988.04	103,775.64	83.85
Education Fund	12210112	PROF. DEVELOPMENT	0.00	0.00	0.00	0.00	0.00	0.00	0.00
Education Fund	12210113	SPECIAL ED TEACHERS -	0.00	0.00	0.00	0.00	0.00	0.00	0.00

Expenditure Report

Fiscal Year: 2021-2022
Month: March

COUNTY OF GRUNDY SCHOOL DIST 111

Fund Description	Account	Account Description	Revised Budget	MTD Activity	Encumbrance	Pending Activity	Available Funds	Year to Date Activity	Percent of Budget Used
Education Fund	122101173	Title II Salaries	0.00	0.00	0.00	0.00	-8,000.00	8,000.00	0.00
Education Fund	12210111	DIR C/I SEC. SALARY	35,934.48	2,796.62	0.00	0.00	9,321.39	26,613.09	74.06
Education Fund		TITLE II TRS	0.00	0.00	0.00	0.00	-263.53	263.53	0.00
Education Fund	10-2210-	DIRECTOR C/I SALARY (BT)	15,164.40	1,263.70	0.00	0.00	2,378.01	12,786.39	84.32
Education Fund	12210211	DIR OF C/I TRS	0.00	0.00	0.00	0.00	0.00	0.00	0.00
Education Fund	10-2210-	DIRECTOR C/I SALARY	0.00	0.00	0.00	0.00	0.00	0.00	0.00
Education Fund	12210222	DIRECTOR C/I INS	26,800.08	2,233.34	0.00	0.00	3,614.31	23,185.77	86.51
Education Fund	12210223	DIR C/I SEC INSURANCE	26,604.24	2,217.02	0.00	0.00	6,788.51	19,815.73	74.48
Education Fund		DIRECTOR C/I DENTAL INS	1,408.56	120.54	0.00	0.00	342.66	1,065.90	75.67
Education Fund		DIR C/I SEC DENTAL INS	441.60	37.78	0.00	0.00	109.74	331.86	75.15
Education Fund	12210305	TITLE II PURCHASE	25,792.00	0.00	0.00	0.00	8,015.00	17,777.00	98 68.92
Education Fund	12200303	IDEA PART B SP ED PROF	0.00	0.00	0.00	0.00	0.00	0.00	0.00
Education Fund	12200304	IDEA PART B SP ED PROF	0.00	0.00	0.00	0.00	0.00	0.00	0.00
Education Fund	12210300	IDEA PART B SP ED PROF	1,957.88	761.92	0.00	367.38	-2,961.42	4,551.92	232.49
Education Fund	12210302	IDEA PART B SP ED PROF	0.00	0.00	0.00	0.00	0.00	0.00	0.00
Education Fund	12210303	IDEA PART B SP ED PROF	0.00	0.00	0.00	0.00	0.00	0.00	0.00
Education Fund	12210304	IDEA PART B SP ED PROF	0.00	0.00	0.00	0.00	0.00	0.00	0.00
Education Fund	12210306	TESTING SERVICE	80,000.00	0.00	0.00	0.00	73,007.80	6,992.20	8.74
Education Fund	12210390	DIRECTOR C/I PURCHASE	0.00	0.00	0.00	0.00	0.00	0.00	0.00
Education Fund	1221031005	PROF DEVEL ENGLISH	3,800.00	1,548.00	0.00	0.00	1,907.00	1,893.00	49.82
Education Fund	1221031106	PROF DEVEL WORLD	3,800.00	1,250.00	0.00	0.00	2,320.00	1,480.00	38.95
Education Fund	1221031210	PROF DEVEL CTE	3,800.00	0.00	525.00	0.00	3,275.00	0.00	0.00
Education Fund	1221030811	PROF DELEV MATH	3,800.00	1,036.00	0.00	0.00	2,251.56	1,548.44	40.75
Education Fund	1221030913	PROF DEVEL SCIENCE	3,800.00	0.00	0.00	0.00	2,644.20	1,155.80	30.42

Expenditure Report

Fiscal Year: 2021-2022
Month: March

COUNTY OF GRUNDY SCHOOL DIST 111

Fund Description	Account	Account Description	Revised Budget	MTD Activity	Encumbrance	Pending Activity	Available Funds	Year to Date Activity	Percent of Budget Used
Education Fund	1221031315	PROF DEVEL SOCIAL	3,800.00	0.00	448.95	0.00	2,693.05	658.00	17.32
Education Fund	1221030750	PROF DEVEL	3,800.00	0.00	0.00	0.00	3,040.00	760.00	20.00
Education Fund	12210301	PROF. DEVELOPMENT	17,000.00	2,095.00	0.00	0.00	11,613.41	5,386.59	31.69
Education Fund	12210401	SPECIAL ED GRANT	0.00	0.00	0.00	0.00	0.00	0.00	0.00
Education Fund	12210400	DIRECTOR C/I SUPPLIES	0.00	0.00	0.00	0.00	-51.50	51.50	0.00
Education Fund	12210402	TITLE II SUPPLIES	0.00	0.00	0.00	0.00	0.00	0.00	0.00
Education Fund	12210640	DIRECTOR C/I	500.00	0.00	0.00	0.00	500.00	0.00	0.00
Education Fund	12210642	DIRECTOR C/I	500.00	0.00	0.00	0.00	500.00	0.00	0.00
Education Fund	12212211	CURR DEVELOP/LEARN	0.00	0.00	0.00	0.00	0.00	0.00	0.00
Education Fund	12213211	TYPE 75 TRS	0.00	0.00	0.00	0.00	0.00	0.00	0.00
Education Fund			0.00	0.00	0.00	0.00	0.00	0.00	99 0.00
Education Fund	12220400	LIBRARY CHAPTER II	0.00	0.00	0.00	0.00	0.00	0.00	0.00
Education Fund	12222110	CYBRARY AIDE SALARY	52,047.60	4,105.42	0.00	0.00	14,276.46	37,771.14	72.57
Education Fund	12222111	LIBRARY SALARY	51,127.92	4,260.66	0.00	0.00	10,729.27	40,398.65	79.01
Education Fund	12222112	CYBRARY AIDE SALARY	26,730.00	2,227.50	0.00	0.00	6,794.70	19,935.30	74.58
Education Fund	12222211	LIBRARY TRS	0.00	0.00	0.00	0.00	0.00	0.00	0.00
Education Fund		LIBRARY TRS	6,137.04	511.42	0.00	0.00	1,243.93	4,893.11	79.73
Education Fund	122222112	LIB ASST TRS S.C.	0.00	0.00	0.00	0.00	0.00	0.00	0.00
Education Fund	12222222	LIBRARY AIDE GROUP INS	26,447.52	2,203.96	0.00	0.00	6,611.88	19,835.64	75.00
Education Fund		LIBRARY GROUP INS	8,520.00	710.00	0.00	0.00	2,130.00	6,390.00	75.00
Education Fund	10-2222-	LIB ASST SALARY S.C.	26,447.52	2,203.96	0.00	0.00	6,611.88	19,835.64	75.00
Education Fund		LIBRARY DENT INS	441.60	37.78	0.00	0.00	107.46	334.14	75.67
Education Fund	12222300	LIBRARY CONTRACT SERV	0.00	0.00	0.00	0.00	0.00	0.00	0.00
Education Fund	122223002	LIBRARY CONT SERV S.C.	0.00	0.00	0.00	0.00	0.00	0.00	0.00

Expenditure Report

Fiscal Year: 2021-2022
Month: March

COUNTY OF GRUNDY SCHOOL DIST 111

Fund Description	Account	Account Description	Revised Budget	MTD Activity	Encumbrance	Pending Activity	Available Funds	Year to Date Activity	Percent of Budget Used
Education Fund	12222410	LIBRARY SUPPLIES	7,800.00	0.00	3,308.59	0.00	1,760.21	2,731.20	35.02
Education Fund	12222411	LIBRARY COMP TECH	0.00	0.00	0.00	0.00	0.00	0.00	0.00
Education Fund	122224102	LIBRARY SUPPLIES S.C.	0.00	0.00	0.00	0.00	0.00	0.00	0.00
Education Fund	122224112	LIBRARY COMP TECH	0.00	0.00	0.00	0.00	0.00	0.00	0.00
Education Fund	12222430	LIBRARY BOOKS	20,000.00	-1,788.13	965.28	-7.96	6,281.31	12,761.37	63.81
Education Fund	12222431	PER CAPITA GRANT	1,978.50	0.00	0.00	0.00	1,978.50	0.00	0.00
Education Fund	122224302	LIBRARY BOOKS S.C.	0.00	0.00	0.00	0.00	0.00	0.00	0.00
Education Fund	12222440	LIBRARY PERIODICALS	60,134.86	0.00	23,796.37	0.00	4,765.67	31,572.82	52.50
Education Fund	122224402	LIBRARY PERIODICALS	0.00	0.00	0.00	0.00	0.00	0.00	0.00
Education Fund	12222540	LIBRARY EQUIPMENT	0.00	0.00	0.00	0.00	0.00	0.00	0.00
Education Fund	122225402	LIBRARY EQUIPMENT S.C.	0.00	0.00	0.00	0.00	0.00	0.00	100 0.00
Education Fund	12222640	LIBRARY DUES/FEES/LIT	0.00	0.00	0.00	0.00	0.00	0.00	0.00
Education Fund	122226402	LIBRARY DUES/FEES/LIT S	0.00	0.00	0.00	0.00	0.00	0.00	0.00
Education Fund	12225110	TECH COORD SALARY	92,031.12	7,669.26	0.00	0.00	23,007.78	69,023.34	75.00
Education Fund	12225111	TECH ASST SALARY	70,404.48	5,867.04	0.00	0.00	17,067.98	53,336.50	75.76
Education Fund	12225112	TECH/CYBRARY AIDE	0.00	0.00	0.00	0.00	0.00	0.00	0.00
Education Fund	12225113	TECH ASST SALARY S.C.	64,147.68	5,345.64	0.00	0.00	16,381.22	47,766.46	74.46
Education Fund	12225120	SUMMER TECH HELPERS	7,000.00	0.00	0.00	0.00	-3,130.25	10,130.25	144.72
Education Fund	12225211	TECH/CYBRARY AIDE TRS	0.00	0.00	0.00	0.00	0.00	0.00	0.00
Education Fund	10-2225-	TECH ASST SALARY S.C.	0.00	0.00	0.00	0.00	0.00	0.00	0.00
Education Fund	12225222	TECHNOLOGY GROUP INS	27,996.24	2,333.02	0.00	0.00	6,999.06	20,997.18	75.00
Education Fund		TECH ASST GROUP INS	27,996.24	2,333.02	0.00	0.00	6,999.06	20,997.18	75.00
Education Fund		TECH COORD GROUP INS	126.48	2,223.56	0.00	0.00	-7,664.79	7,791.27	6,160.08
Education Fund		TECH COORD DENTAL INS	0.00	0.00	0.00	0.00	0.00	0.00	0.00

Expenditure Report

Fiscal Year: 2021-2022
Month: March

COUNTY OF GRUNDY SCHOOL DIST 111

Fund Description	Account	Account Description	Revised Budget	MTD Activity	Encumbrance	Pending Activity	Available Funds	Year to Date Activity	Percent of Budget Used
Education Fund		TECH ASST DENTAL INS	441.60	37.78	0.00	0.00	107.46	334.14	75.67
Education Fund		TECH/HR DENTAL INS	220.80	18.90	0.00	0.00	7.70	213.10	96.51
Education Fund	12225300	COMPUTER CONTRACT	5,000.00	0.00	0.00	0.00	3,932.42	1,067.58	21.35
Education Fund	12225301	INTERNET SERVICE	57,000.00	5,091.04	0.00	81.90	21,229.90	35,688.20	62.61
Education Fund	12225390	CLOSING THE GAP	0.00	0.00	0.00	0.00	0.00	0.00	0.00
Education Fund	12225393	POWER SCHOOL TECH	60,000.00	0.00	0.00	0.00	16,470.42	43,529.58	72.55
Education Fund	12225400	COMPUTER RESALE	29.00	0.00	0.00	0.00	29.00	0.00	0.00
Education Fund	12225410	COMPUTER SUPPLIES	32,000.00	794.90	1,348.94	0.00	11,945.28	18,705.78	58.46
Education Fund	12225411	COMPUTER COMP TECH	0.00	0.00	0.00	0.00	0.00	0.00	0.00
Education Fund	12225420	COMPUTER TEXTBOOKS	0.00	0.00	0.00	0.00	0.00	0.00	0.00
Education Fund	12225490	COMPUTER SOFTWARE	154,000.00	150.00	3,089.96	1,100.02	-15,637.21	165,447.23	107.43
Education Fund	12225540	COMPUTER EQUIPMENT	361,111.57	3,013.56	596.00	0.00	246,022.01	114,493.56	31.71
Education Fund	12225541	TECH COMPUTER LEASE	400,000.00	0.00	339,278.07	0.00	-304,166.29	364,888.22	91.22
Education Fund	12225542	COMPUTER LEASE	0.00	0.00	0.00	0.00	0.00	0.00	0.00
Education Fund	12225543	POWER SCHOOL	0.00	0.00	0.00	0.00	0.00	0.00	0.00
Education Fund	12225640	COMPUTER DUES &	0.00	0.00	0.00	0.00	0.00	0.00	0.00
Education Fund	12225710	COMPUTERS - NON	0.00	0.00	0.00	0.00	0.00	0.00	0.00
Education Fund		DIST 111 GROUP DENTAL	0.00	0.00	0.00	0.00	0.00	0.00	0.00
Education Fund	12230300	TITLE 1 PURCHASE	0.00	0.00	0.00	0.00	0.00	0.00	0.00
Education Fund	12230400	IDEA SUPPLIES SOC	2,281.25	0.00	0.00	0.00	1,915.05	366.20	16.05
Education Fund	12300100	TITLE 1 DIRECTOR	0.00	0.00	0.00	0.00	0.00	0.00	0.00
Education Fund	12300120	TEST PROCTOR	2,388.83	0.00	0.00	0.00	2,388.83	0.00	0.00
Education Fund	10-2300-211	TEST PROCTOR (BT)	232.57	0.00	0.00	0.00	232.57	0.00	0.00
Education Fund	10-2300-222	TEST PROCTOR (BME)	0.00	0.00	0.00	0.00	0.00	0.00	0.00

Expenditure Report

Fiscal Year: 2021-2022
Month: March

COUNTY OF GRUNDY SCHOOL DIST 111

Fund Description	Account	Account Description	Revised Budget	MTD Activity	Encumbrance	Pending Activity	Available Funds	Year to Date Activity	Percent of Budget Used
Education Fund	12300500	IDEA GRANT DIR STUDENT	0.00	0.00	0.00	0.00	0.00	0.00	0.00
Education Fund	12310200	BOARD OF ED-OTHER	0.00	0.00	0.00	0.00	0.00	0.00	0.00
Education Fund	12310211	BOARD OF ED TRS	0.00	0.00	0.00	0.00	0.00	0.00	0.00
Education Fund	12310222	COBRA INSURANCE	0.00	0.00	0.00	0.00	0.00	0.00	0.00
Education Fund	12310301	FORMER EMPLOYEE	0.00	0.00	0.00	0.00	0.00	0.00	0.00
Education Fund	12310300	BOARD OF ED PUR SERV	65,000.00	6,290.00	0.00	0.00	42,030.33	22,969.67	35.34
Education Fund	12310302	COBRA INSURANCE	0.00	0.00	0.00	0.00	0.00	0.00	0.00
Education Fund	12310310	ARCHITECT FEES	25,000.00	0.00	0.00	0.00	23,912.50	1,087.50	4.35
Education Fund	12310311	HEARING OFFICER PUR	5,000.00	0.00	0.00	1,275.00	200.00	3,525.00	70.50
Education Fund	12310316	TREES ADMIN	5,000.00	0.00	0.00	0.00	75.00	4,925.00	98.50
Education Fund	12310314	COLLECTION FEE CC	35,000.00	1,093.84	0.00	0.00	6,928.95	28,071.05	10280.20
Education Fund	12310317	AUDIT SERVICES	12,500.00	0.00	0.00	0.00	2,000.00	10,500.00	84.00
Education Fund	12310315	ASSESSMENT APPEALS	0.00	0.00	0.00	0.00	0.00	0.00	0.00
Education Fund	12310318	ATTORNEY FEES	0.00	0.00	0.00	0.00	0.00	0.00	0.00
Education Fund	12310319	BACKGROUND INVEST	0.00	0.00	0.00	0.00	0.00	0.00	0.00
Education Fund	12310380	GEN LIABILITY INSURANCE	0.00	0.00	0.00	0.00	0.00	0.00	0.00
Education Fund	12310381	INSURANCE CONSULTING	0.00	0.00	0.00	0.00	0.00	0.00	0.00
Education Fund	12310382	TREASURERS BOND	12,000.00	0.00	0.00	0.00	2,299.00	9,701.00	80.84
Education Fund	12310390	BOARD OF ED/OTH PUR	0.00	0.00	0.00	0.00	0.00	0.00	0.00
Education Fund	12310411	DONATIONS	0.00	0.00	0.00	0.00	0.00	0.00	0.00
Education Fund	12310410	BOARD OF ED SUPPLIES	35,000.00	-881.46	0.00	194.82	21,807.71	12,997.47	37.14
Education Fund	12310412	EDUCATION FOUNDATION	0.00	699.99	0.00	0.00	-1,311.99	1,311.99	0.00
Education Fund	12310540	BOARD OF ED EQUIPMENT	0.00	0.00	0.00	0.00	0.00	0.00	0.00
Education Fund	12310640	BOARD OF ED CLINICS	8,000.00	0.00	0.00	0.00	80.33	7,919.67	99.00

Expenditure Report

Fiscal Year: 2021-2022
Month: March

COUNTY OF GRUNDY SCHOOL DIST 111

Fund Description	Account	Account Description	Revised Budget	MTD Activity	Encumbrance	Pending Activity	Available Funds	Year to Date Activity	Percent of Budget Used
Education Fund	12310641	BOARD OF ED DUES	36,000.00	0.00	0.00	0.00	33,137.00	2,863.00	7.95
Education Fund	12312110	BOARD SECY SALARY	0.00	0.00	0.00	0.00	0.00	0.00	0.00
Education Fund	12313110	PERFORMANCE PAY	0.00	0.00	0.00	0.00	0.00	0.00	0.00
Education Fund	12313211	PERFORMANCE TRS	0.00	0.00	0.00	0.00	0.00	0.00	0.00
Education Fund	12313216	PERFORMANCE ANNUITY	0.00	0.00	0.00	0.00	0.00	0.00	0.00
Education Fund	12321110	SUPT SECY SALARY	51,765.60	5,643.80	0.00	0.00	15,925.20	35,840.40	69.24
Education Fund	12321111	SUPT SALARY	201,458.16	16,788.18	0.00	0.00	50,364.54	151,093.62	75.00
Education Fund	12321112	PRIOR SUPERINTENDENT	0.00	0.00	0.00	0.00	0.00	0.00	0.00
Education Fund	12321113	INTERIM SUPT SALARY	0.00	0.00	0.00	0.00	0.00	0.00	0.00
Education Fund	12321211	SUPT TRS	0.00	0.00	0.00	0.00	0.00	0.00	0.00
Education Fund	12321212	INTERIM SUPT TRS	27,000.00	2,057.02	0.00	0.00	8,486.82	18,513.18	10368.57
Education Fund	12321216	SUPT ANNUITY	0.00	0.00	0.00	0.00	0.00	0.00	0.00
Education Fund	10-2321-	SUPT SALARY (GTL)	0.00	0.00	0.00	0.00	0.00	0.00	0.00
Education Fund	12321222	SUPT GROUP INS	8,700.00	2,217.02	0.00	0.00	-9,044.69	17,744.69	203.96
Education Fund	12321223	SUPT SECY GROUP INS	8,665.92	722.16	0.00	0.00	2,166.48	6,499.44	75.00
Education Fund		SUPT SEC DENTAL INS	441.60	37.78	0.00	0.00	125.86	315.74	71.50
Education Fund		SUPT DENTAL INS	441.60	37.78	0.00	0.00	107.46	334.14	75.67
Education Fund	12321390	SUPT CONTRACT SERV	0.00	0.00	0.00	0.00	0.00	0.00	0.00
Education Fund	12321310	SUPT PHYSICAL	0.00	0.00	0.00	0.00	0.00	0.00	0.00
Education Fund	12321323	SUPT REPAIR/MAINT	0.00	0.00	0.00	0.00	0.00	0.00	0.00
Education Fund	12321332	SUPT SECY MILEAGE	0.00	0.00	0.00	0.00	0.00	0.00	0.00
Education Fund	12321333	SUPT MILEAGE	1,500.00	377.91	0.00	0.00	62.05	1,437.95	95.86
Education Fund	12321410	SUPT SUPPLIES	0.00	0.00	0.00	0.00	-1,994.83	1,994.83	0.00
Education Fund	12321540	SUPT EQUIPMENT	0.00	0.00	0.00	0.00	0.00	0.00	0.00

Expenditure Report

Fiscal Year: 2021-2022
Month: March

COUNTY OF GRUNDY SCHOOL DIST 111

Fund Description	Account	Account Description	Revised Budget	MTD Activity	Encumbrance	Pending Activity	Available Funds	Year to Date Activity	Percent of Budget Used
Education Fund	12321640	SUPT DUES/LIT	2,000.00	0.00	0.00	0.00	1,340.00	660.00	33.00
Education Fund	12321641	SUPT SECY CLINIC	0.00	0.00	0.00	0.00	0.00	0.00	0.00
Education Fund	12321642	SUPT CLINIC	0.00	35.00	0.00	0.00	-923.54	923.54	0.00
Education Fund	12300400	IDEA GRANT GENERAL	0.00	0.00	0.00	0.00	0.00	0.00	0.00
Education Fund	12410110	PRIN SECYS SALARY	40,599.12	3,479.26	0.00	0.00	10,053.78	30,545.34	75.24
Education Fund	12410111	PRINCIPAL SALARY	144,615.36	12,051.28	0.00	0.00	36,153.84	108,461.52	75.00
Education Fund	12410112	ASST PRIN SECY SALARY	55,281.84	4,606.82	0.00	0.00	13,820.46	41,461.38	75.00
Education Fund	12410113	ASST PRINCIPAL SALARY	124,145.28	10,345.44	0.00	0.00	31,036.32	93,108.96	75.00
Education Fund	12410115	DEANS SALARY	308,118.24	25,676.52	0.00	0.00	82,240.42	225,877.82	73.31
Education Fund	124101132	ASST PRIN SALARY S.C.	105,000.00	8,750.00	0.00	0.00	26,250.00	78,750.00	75.00
Education Fund	12410114	PRINCIPAL SALARY S.C.	0.00	0.00	0.00	0.00	0.00	0.00	104 0.00
Education Fund	12410211	PRINCIPAL TRS	0.00	0.00	0.00	0.00	0.00	0.00	0.00
Education Fund	12410212	PRINCIPAL TRS	17,719.44	1,476.62	0.00	0.00	4,429.86	13,289.58	75.00
Education Fund		ASST PRINCIPAL TRS	15,211.44	1,267.62	0.00	0.00	3,802.86	11,408.58	75.00
Education Fund		DEANS TRS	36,984.24	3,082.01	0.00	0.00	9,635.94	27,348.30	73.95
Education Fund	12410214	PRINCIPAL TRS S.C.	12,865.44	1,072.12	0.00	0.00	3,216.36	9,649.08	75.00
Education Fund	10-2410-	PRINCIPAL SALARY (GTL)	0.00	0.00	0.00	0.00	0.00	0.00	0.00
Education Fund	10-2410-	ASST PRIN SALARY S.C.	0.00	0.00	0.00	0.00	0.00	0.00	0.00
Education Fund	12410222	PRIN SEC GROUP INS	8,960.16	746.68	0.00	0.00	2,240.04	6,720.12	75.00
Education Fund	12410223	PRINCIPAL GROUP INS	26,820.24	2,235.02	0.00	0.00	6,705.06	20,115.18	75.00
Education Fund	12410224	ASST PRIN GROUP INS	18,169.92	1,514.16	0.00	0.00	4,542.48	13,627.44	75.00
Education Fund		ASST PRIN GROUP INS	28,193.04	2,349.42	0.00	0.00	7,048.26	21,144.78	75.00
Education Fund		DEANS GROUP INS	69,228.24	5,769.02	0.00	0.00	19,246.94	49,981.30	72.20
Education Fund	10-2410-	ASST PRIN SALARY S	334.32	27.86	0.00	0.00	83.58	250.74	75.00

Expenditure Report

Fiscal Year: 2021-2022
Month: March

COUNTY OF GRUNDY SCHOOL DIST 111

Fund Description	Account	Account Description	Revised Budget	MTD Activity	Encumbrance	Pending Activity	Available Funds	Year to Date Activity	Percent of Budget Used
Education Fund		PRIN SEC DENTAL INS	441.60	37.78	0.00	0.00	107.46	334.14	75.67
Education Fund		PRINCIPAL DENTAL INS	1,408.56	120.54	0.00	0.00	342.66	1,065.90	75.67
Education Fund		ASST PRIN SEC DENTAL	441.60	37.78	0.00	0.00	107.46	334.14	75.67
Education Fund		ASST PRIN DENTAL INS	1,408.56	120.54	0.00	0.00	342.66	1,065.90	75.67
Education Fund		DEANS DENTAL INS	1,545.60	132.24	0.00	0.00	408.28	1,137.32	73.58
Education Fund		ASST PRIN S.C. DENTAL	0.00	0.00	0.00	0.00	0.00	0.00	0.00
Education Fund	12410390	ASST PRIN PURCHASE	10,000.00	-150.00	0.00	0.00	10,150.00	-150.00	-1.50
Education Fund	12410391	PRIN PURCHASE SERV	13,000.00	0.00	0.00	0.00	13,000.00	0.00	0.00
Education Fund	124103902	ASST PRIN CONT SERV S	0.00	0.00	0.00	0.00	0.00	0.00	0.00
Education Fund	124103912	PRIN CONT SERV S	0.00	0.00	0.00	0.00	0.00	0.00	0.00
Education Fund	12410340	POSTAGE	31,000.00	1,000.00	0.00	5,773.19	13,548.45	11,678.36	10537.67
Education Fund	12410410	ASST PRIN SUPPLIES	9,000.00	0.00	0.00	0.00	-4,813.70	13,813.70	153.49
Education Fund	12410411	PRINCIPAL SUPPLIES	15,000.00	474.42	104.52	0.00	2,873.04	12,022.44	80.15
Education Fund	12410412	GRADUATION SUPPLIES	15,000.00	113.59	0.00	0.00	10,643.73	4,356.27	29.04
Education Fund	12410413	PRINCIPAL COMP TECH	0.00	0.00	0.00	0.00	0.00	0.00	0.00
Education Fund	12410414	ASST PRIN COMP TECH	0.00	0.00	0.00	0.00	0.00	0.00	0.00
Education Fund	12410415	IMTT GRANT SUPPLIES	5,000.00	0.00	0.00	0.00	5,000.00	0.00	0.00
Education Fund	124104102	ASST PRIN SUPPLIES S	8,000.00	0.00	0.00	0.00	7,948.50	51.50	0.64
Education Fund	124104112	PRINCIPAL SUPPLIES S	0.00	0.00	0.00	0.00	0.00	0.00	0.00
Education Fund	124104132	PRINCIPAL COMP TECH	0.00	0.00	0.00	0.00	0.00	0.00	0.00
Education Fund	124104142	ASST PRIN COMP TECH	0.00	0.00	0.00	0.00	0.00	0.00	0.00
Education Fund	12410540	PRINCIPAL EQUIPMENT	0.00	0.00	0.00	0.00	0.00	0.00	0.00
Education Fund	12410541	ASST PRIN EQUIPMENT	0.00	0.00	0.00	0.00	0.00	0.00	0.00
Education Fund	124105402	PRINCIPAL EQUIPMENT S	0.00	0.00	0.00	0.00	0.00	0.00	0.00

Expenditure Report

Fiscal Year: 2021-2022
Month: March

COUNTY OF GRUNDY SCHOOL DIST 111

Fund Description	Account	Account Description	Revised Budget	MTD Activity	Encumbrance	Pending Activity	Available Funds	Year to Date Activity	Percent of Budget Used
Education Fund	124105412	ASST PRIN EQUIPMENT S	0.00	0.00	0.00	0.00	0.00	0.00	0.00
Education Fund	12410640	PRINCIPAL DUES/LIT	2,500.00	0.00	0.00	0.00	1,303.00	1,197.00	47.88
Education Fund	12410641	ASST PRIN DUES/LIT	500.00	0.00	0.00	0.00	-98.00	598.00	119.60
Education Fund	12410642	PRINCIPAL	2,000.00	303.03	0.00	0.00	1,148.23	851.77	42.59
Education Fund	12410643	ASST PRIN	500.00	0.00	0.00	0.00	500.00	0.00	0.00
Education Fund	12410644	SPC DUES	9,000.00	0.00	0.00	0.00	3,300.00	5,700.00	63.33
Education Fund	124106402	PRINCIPAL DUES/LIT S	0.00	0.00	0.00	0.00	0.00	0.00	0.00
Education Fund	124106412	ASST PRIN DUES/LIT S	0.00	0.00	0.00	0.00	0.00	0.00	0.00
Education Fund	124106422	PRINCIPAL	0.00	0.00	0.00	0.00	0.00	0.00	0.00
Education Fund	124106432	ASST PRIN	500.00	0.00	0.00	0.00	500.00	0.00	0.00
Education Fund	12490110	DEANS SECY SALARY	62,006.88	4,946.60	0.00	0.00	15,341.73	46,665.15	10675.26
Education Fund	12490112	DEANS SALARY	0.00	0.00	0.00	0.00	0.00	0.00	0.00
Education Fund	12490212	DEANS TRS	0.00	0.00	0.00	0.00	0.00	0.00	0.00
Education Fund	12490222	DEANS SEC INS	39,003.60	3,250.30	0.00	0.00	7,600.17	31,403.43	80.51
Education Fund	12490223	DEANS GROUP INS	0.00	0.00	0.00	0.00	0.00	0.00	0.00
Education Fund		DEAN SEC DENTAL INS	545.04	46.62	0.00	0.00	92.14	452.90	83.09
Education Fund	12490390	DEANS PURCHASE	1,000.00	398.00	0.00	0.00	602.00	398.00	39.80
Education Fund	124903902	DEANS CONT SERV S	0.00	0.00	0.00	0.00	0.00	0.00	0.00
Education Fund	12490410	DEANS SUPPLIES	4,000.00	0.00	0.00	0.00	3,575.55	424.45	10.61
Education Fund	12490411	DEANS COMP TECH	0.00	0.00	0.00	0.00	0.00	0.00	0.00
Education Fund	124904102	DEANS SUPPLIES S	0.00	0.00	0.00	0.00	0.00	0.00	0.00
Education Fund	124904112	DEANS COMP TECH	0.00	0.00	0.00	0.00	0.00	0.00	0.00
Education Fund	12490540	DEANS EQUIPMENT	0.00	0.00	0.00	0.00	0.00	0.00	0.00
Education Fund	124905402	DEANS EQUIPMENT S	0.00	0.00	0.00	0.00	0.00	0.00	0.00

Expenditure Report

Fiscal Year: 2021-2022
Month: March

COUNTY OF GRUNDY SCHOOL DIST 111

Fund Description	Account	Account Description	Revised Budget	MTD Activity	Encumbrance	Pending Activity	Available Funds	Year to Date Activity	Percent of Budget Used
Education Fund	12490640	DEANS MILEAGE	0.00	0.00	0.00	0.00	0.00	0.00	0.00
Education Fund	12490641	DEANS PROF DUES &	0.00	0.00	0.00	0.00	0.00	0.00	0.00
Education Fund	124906402	DEANS MILEAGE S	0.00	0.00	0.00	0.00	0.00	0.00	0.00
Education Fund	124906412	DEANS DUES/LIT S	0.00	0.00	0.00	0.00	0.00	0.00	0.00
Education Fund	12510110	CSBO SALARY	57,969.84	4,830.82	0.00	0.00	14,492.46	43,477.38	75.00
Education Fund	12510211	CSBO TRS	0.00	0.00	0.00	0.00	0.00	0.00	0.00
Education Fund	10-2510-	CSBO SALARY (BIMRF)	0.00	227.62	0.00	0.00	-1,114.71	1,114.71	0.00
Education Fund	10-2510-	CSBO SALARY (GTL)	0.00	0.00	0.00	0.00	0.00	0.00	0.00
Education Fund	12510222	CSBO GROUP INS	8,951.04	745.92	0.00	0.00	2,237.76	6,713.28	75.00
Education Fund		CSBO DENTAL INS	469.68	40.18	0.00	0.00	114.30	355.38	75.66
Education Fund	12510332	CSBO MILEAGE	2,000.00	0.00	0.00	0.00	2,000.00	0.00	107 0.00
Education Fund	12510640	CSBO DUES/CLINICS	4,000.00	0.00	0.00	0.00	3,621.00	379.00	9.48
Education Fund	12510641	SECY SUPPORT CLINICS	0.00	0.00	0.00	0.00	0.00	0.00	0.00
Education Fund	12525110	BUSINESS OFFICE SALARY	196,374.96	16,217.38	0.00	0.00	61,960.84	134,414.12	68.45
Education Fund	12525222	BUSINESS OFFICE GRP	16,314.24	2,065.52	0.00	0.00	4,930.75	11,383.49	69.78
Education Fund		10 E 2525 2230 00 300	1,059.84	128.44	0.00	0.00	153.80	906.04	85.49
Education Fund	12525390	BUSINESS OFFICE PUR	10,000.00	60.00	0.00	60.00	9,072.00	868.00	8.68
Education Fund	12525323	BUSINESS OFFICE REPAIR	0.00	0.00	0.00	0.00	0.00	0.00	0.00
Education Fund	12525332	BOOKKEEPER MILEAGE	400.00	0.00	0.00	0.00	400.00	0.00	0.00
Education Fund	12525391	BUSINESS OFFICE CONT	0.00	0.00	0.00	0.00	0.00	0.00	0.00
Education Fund	12525411	BUSINESS OFFICE COMP	0.00	0.00	0.00	0.00	0.00	0.00	0.00
Education Fund	12525410	BUSINESS OFFICE	3,500.00	557.26	18.97	389.70	573.72	2,517.61	71.93
Education Fund	12525540	BUSINESS OFFICE	2,500.00	0.00	0.00	0.00	2,500.00	0.00	0.00
Education Fund	12525640	BOOKKEEPER CLINICS	500.00	0.00	0.00	0.00	500.00	0.00	0.00

Expenditure Report

Fiscal Year: 2021-2022
Month: March

COUNTY OF GRUNDY SCHOOL DIST 111

Fund Description	Account	Account Description	Revised Budget	MTD Activity	Encumbrance	Pending Activity	Available Funds	Year to Date Activity	Percent of Budget Used
Education Fund	12560300	CAFETERIA CONTRACT	500,000.00	108,511.66	0.00	0.00	-301,405.86	801,405.86	160.28
Education Fund	12560302	CAFE TECH CONT SERV	0.00	0.00	0.00	0.00	0.00	0.00	0.00
Education Fund	125603002	CAFE PUR SER SOUTH	0.00	0.00	0.00	0.00	0.00	0.00	0.00
Education Fund	12560301	SPECIAL FUNCTION	35,000.00	0.00	0.00	0.00	35,000.00	0.00	0.00
Education Fund	125603012	SPECIAL FUNCTION	0.00	0.00	0.00	0.00	0.00	0.00	0.00
Education Fund	12560323	CAFETERIA REPAIR/MAINT	0.00	0.00	0.00	0.00	0.00	0.00	0.00
Education Fund	125603232	CAFE REPAIR/MAINT	0.00	0.00	0.00	0.00	0.00	0.00	0.00
Education Fund	12560410	CAFETERIA SUPPLIES	4,000.00	0.00	0.00	0.00	4,000.00	0.00	0.00
Education Fund	12560411	CAFE COMP TECH	0.00	0.00	0.00	0.00	0.00	0.00	0.00
Education Fund	125604102	CAFE SUPPLIES SOUTH	0.00	0.00	0.00	0.00	0.00	0.00	0.00
Education Fund	125604112	CAFE COMP TECH	0.00	0.00	0.00	0.00	0.00	0.00	108 0.00
Education Fund	12560540	CAFETERIA EQUIPMENT	5,000.00	0.00	0.00	0.00	5,000.00	0.00	0.00
Education Fund	125605402	CAFE EQUIPMENT SOUTH	0.00	0.00	0.00	0.00	0.00	0.00	0.00
Education Fund	125606902	CAFE SOUTH REFUND	0.00	0.00	0.00	0.00	0.00	0.00	0.00
Education Fund	12632110	INTERNAL INFO SALARY	27,820.32	2,186.80	0.00	0.00	7,167.50	20,652.82	74.24
Education Fund	12632211	INTERNAL INFO TRS	0.00	0.00	0.00	0.00	0.00	0.00	0.00
Education Fund	12632222	INTERNAL INFO GROUP	13,302.24	1,108.52	0.00	0.00	2,802.84	10,499.40	78.93
Education Fund		DEAN/PRINT ROOM	220.80	18.90	0.00	0.00	53.70	167.10	75.68
Education Fund	12632390	INTERNAL INFO PUR	400,000.00	3,950.00	8,436.10	3,950.00	299,030.68	88,583.22	22.15
Education Fund	12632323	INTERNAL INFO	0.00	0.00	0.00	0.00	0.00	0.00	0.00
Education Fund	12632411	INTERNAL INFO COMP	0.00	0.00	0.00	0.00	0.00	0.00	0.00
Education Fund	12632410	INTERNAL INFO SUPPLIES	2,000.00	0.00	0.00	0.00	2,000.00	0.00	0.00
Education Fund	12632540	INTERNAL INFO EQUIP	0.00	0.00	0.00	0.00	0.00	0.00	0.00
Education Fund	12633110	COMM RELATIONS	71,716.80	6,597.44	0.00	0.00	13,997.37	57,719.43	80.48

Expenditure Report

Fiscal Year: 2021-2022
Month: March

COUNTY OF GRUNDY SCHOOL DIST 111

Fund Description	Account	Account Description	Revised Budget	MTD Activity	Encumbrance	Pending Activity	Available Funds	Year to Date Activity	Percent of Budget Used
Education Fund	12633222	COMM RELATIONS GROUP	0.00	710.00	0.00	0.00	-2,155.99	2,155.99	0.00
Education Fund		10 E 2633 2230 00 300	0.00	37.78	0.00	0.00	-113.34	113.34	0.00
Education Fund	12633390	COMM RELATIONS PUR	12,000.00	0.00	0.00	0.00	12,000.00	0.00	0.00
Education Fund	12633323	COMM RELATIONS	0.00	0.00	0.00	0.00	0.00	0.00	0.00
Education Fund	12633332	COMM RELATIONS	0.00	0.00	0.00	0.00	0.00	0.00	0.00
Education Fund	12633410	COMM RELATIONS	500.00	0.00	0.00	0.00	345.83	154.17	30.83
Education Fund	12633540	COMM RELATIONS	0.00	0.00	0.00	0.00	0.00	0.00	0.00
Education Fund	12633640	COMM RELATIONS DUES	1,000.00	-280.00	0.00	0.00	1,015.00	-15.00	-1.50
Education Fund	12900400	TITLE 1 HOMELESS	1,000.00	0.00	0.00	0.00	1,000.00	0.00	0.00
Education Fund	13000300	TITLE 1 PARENT	1,000.00	0.00	0.00	0.00	1,000.00	0.00	0.00
Education Fund	13000400	TITLE 1 PARENT	1,000.00	0.00	0.00	0.00	1,000.00	0.00	109 0.00
Education Fund	13200130	WELLNESS	0.00	0.00	0.00	0.00	0.00	0.00	0.00
Education Fund	13200131	WELLNESS CNTR/PUBLIC	0.00	0.00	0.00	0.00	0.00	0.00	0.00
Education Fund	13200211	WELLNESS CENTER TRS	0.00	0.00	0.00	0.00	0.00	0.00	0.00
Education Fund	10-3200-	WELLNESS	0.00	0.00	0.00	0.00	0.00	0.00	0.00
Education Fund	13200500	WELNESS CENTER	10,000.00	0.00	14,125.20	0.00	-14,125.20	10,000.00	100.00
Education Fund		GCSEC Tuition IDEA Flow	0.00	20,670.00	0.00	20,670.00	-252,598.75	231,928.75	0.00
Education Fund	14100110	TITLE I SALARY	0.00	0.00	0.00	0.00	0.00	0.00	0.00
Education Fund	14100300	TITLE I PUR SERV	0.00	0.00	0.00	0.00	0.00	0.00	0.00
Education Fund	14100332	TITLE II	0.00	0.00	0.00	0.00	0.00	0.00	0.00
Education Fund	14100390	TITLE II-PART D	0.00	0.00	0.00	0.00	0.00	0.00	0.00
Education Fund	14100412	TITLE IV	0.00	0.00	0.00	0.00	0.00	0.00	0.00
Education Fund	14100411	TITLE V SUPPLIES	0.00	0.00	0.00	0.00	0.00	0.00	0.00
Education Fund	14100540	TITLE V EQUIPMENT	0.00	0.00	0.00	0.00	0.00	0.00	0.00

Expenditure Report

Fiscal Year: 2021-2022
Month: March

COUNTY OF GRUNDY SCHOOL DIST 111

Fund Description	Account	Account Description	Revised Budget	MTD Activity	Encumbrance	Pending Activity	Available Funds	Year to Date Activity	Percent of Budget Used
Education Fund	14120300	COOP HOUSING ASSESS	0.00	0.00	0.00	0.00	0.00	0.00	0.00
Education Fund	14120301	COOP ADMIN ASSESS	0.00	0.00	0.00	0.00	0.00	0.00	0.00
Education Fund	14120670	COOP HOMEBOUND/HOSP	15,000.00	0.00	0.00	0.00	15,000.00	0.00	0.00
Education Fund	14140600	GAVC ED EXPENSE	750,000.00	27,695.56	0.00	0.00	382,355.65	367,644.35	49.02
Education Fund	14180	DISBURSEMENTS/EXPEND	0.00	0.00	0.00	0.00	0.00	0.00	0.00
Education Fund	14190600	CHANNAHON TAX	65,000.00	0.00	0.00	0.00	-125,415.06	190,415.06	292.95
Education Fund	14210670	PAYMENTS FOR REGULAR	0.00	0.00	0.00	0.00	0.00	0.00	0.00
Education Fund	14220670	PAYMENTS SPECIAL ED	2,419,617.00	183,588.68	0.00	177,300.91	736,612.70	1,505,703.39	62.23
Education Fund	10-481-212-	IMRF (BIM)	0.00	0.00	0.00	0.00	0.00	0.00	0.00
Education Fund	10-481-212-	IMRF (BIM)	0.00	0.00	0.00	0.00	0.00	0.00	0.00
Education Fund	10-481-222-	IMRF (BMF 3000)	0.00	0.00	0.00	0.00	0.00	0.00	110 0.00
Education Fund	10-481-222-	IMRF (BMF 3000)	0.00	0.00	0.00	0.00	0.00	0.00	0.00
Education Fund	15900390	SERVICE CHARGE	0.00	0.00	0.00	0.00	0.00	0.00	0.00
Education Fund	18130660	PERM TRANS TO O & M	0.00	0.00	0.00	0.00	0.00	0.00	0.00
Education Fund	18400660	TRANS TO DEBT	0.00	0.00	0.00	0.00	0.00	0.00	0.00
Education Fund	18500660	TRANS TO DEBT	0.00	0.00	0.00	0.00	0.00	0.00	0.00
10 - -----			36,048,347.77	2,766,294.70	504,901.24	316,781.91	9,148,017.54	26,078,647.08	
Activity Fund	111999	STUDENT ACTIVITY	0.00	0.00	0.00	0.00	0.00	0.00	0.00
Activity Fund		SPORTS - ATHLETIC HALL	0.00	0.00	0.00	0.00	0.00	0.00	0.00
Activity Fund		SPORTS - ATHLETIC POP	9,923.92	0.00	680.00	1,690.00	4,609.13	2,944.79	29.67
Activity Fund		SPORTS - ATHLETIC	0.00	0.00	0.00	0.00	-408.54	408.54	0.00
Activity Fund		SPORTS - BASEBALL	2,642.50	156.00	0.00	131.00	-14,495.80	17,007.30	643.61
Activity Fund		SPORTS - BOYS	7,502.20	1,808.10	2,211.40	160.00	-503.20	5,634.00	75.10
Activity Fund		SPORTS - BOYS BOWLING	1,040.00	0.00	0.00	0.00	160.00	880.00	84.62

Expenditure Report

Fiscal Year: 2021-2022
Month: March

COUNTY OF GRUNDY SCHOOL DIST 111

Fund Description	Account	Account Description	Revised Budget	MTD Activity	Encumbrance	Pending Activity	Available Funds	Year to Date Activity	Percent of Budget Used
Activity Fund		SPORTS - BOYS GOLF	369.00	0.00	0.00	0.00	318.00	51.00	13.82
Activity Fund		SPORTS - BOYS SOCCER	3,580.46	0.00	6,953.56	0.00	-10,409.89	7,036.79	196.53
Activity Fund		SPORTS - BOYS TENNIS	609.80	0.00	2,339.12	0.00	-1,729.32	0.00	0.00
Activity Fund		SPORTS - BOYS TRACK	11,903.73	392.30	725.79	0.00	9,703.45	1,474.49	12.39
Activity Fund		SPORTS - BOYS	59.54	0.00	361.00	0.00	-301.46	0.00	0.00
Activity Fund		SPORTS - CHEERLEADERS	20,616.81	3,299.80	0.00	0.00	-7,574.83	28,191.64	136.74
Activity Fund		SPORTS - CROSS COUNTY	5,199.85	4,524.07	0.00	0.00	-8,849.98	14,049.83	270.20
Activity Fund		SPORTS - FOOTBALL	45,465.61	1,739.94	21,366.42	-4.97	-30,282.74	54,386.90	119.62
Activity Fund		SPORTS - FOOTBALL	0.00	0.00	0.00	0.00	-1,324.00	1,324.00	0.00
Activity Fund		SPORTS - GIRLS	2,958.42	0.00	0.00	2,007.00	-1,828.80	2,780.22	93.98
Activity Fund		SPORTS - GIRLS BOWLING	640.00	273.93	0.00	0.00	18.07	621.93	1197.18
Activity Fund		SPORTS - GIRLS GOLF	0.00	0.00	0.00	0.00	0.00	0.00	0.00
Activity Fund		SPORTS - GIRLS SOCCER	4,817.03	0.00	0.00	876.87	3,940.16	0.00	0.00
Activity Fund		SPORTS - GIRLS TENNIS	1,450.85	0.00	0.00	0.00	1,309.10	141.75	9.77
Activity Fund		SPORTS - GIRLS TRACK	4,128.80	1,240.61	0.00	634.52	802.52	2,691.76	65.19
Activity Fund		SPORTS - GIRLS	4,484.50	0.00	0.00	1,020.00	413.63	3,050.87	68.03
Activity Fund		SPORTS - LACROSSE	7,382.37	0.00	0.00	0.00	8,728.71	-1,346.34	-18.24
Activity Fund		SPORTS - OUTDOOR ED	0.00	0.00	0.00	0.00	0.00	0.00	0.00
Activity Fund		SPORTS - POMS	3,079.30	9,168.96	2,296.58	480.25	-20,315.60	20,618.07	669.57
Activity Fund		SPORTS - SOFTBALL	3,062.38	2,515.26	0.00	0.00	409.87	2,652.51	86.62
Activity Fund		SPORTS - SWIMMING B&G	0.00	0.00	0.00	0.00	0.00	0.00	0.00
Activity Fund		SPORTS - WRESTLING	370.00	1,142.00	0.00	0.00	-2,234.80	2,604.80	704.00
Activity Fund		SUMMER CAMPS - BAND	1,229.01	0.00	0.00	0.00	0.00	1,229.01	100.00
Activity Fund		SUMMER CAMPS -	0.00	0.00	0.00	0.00	0.00	0.00	0.00

Expenditure Report

Fiscal Year: 2021-2022
Month: March

COUNTY OF GRUNDY SCHOOL DIST 111

Fund Description	Account	Account Description	Revised Budget	MTD Activity	Encumbrance	Pending Activity	Available Funds	Year to Date Activity	Percent of Budget Used
Activity Fund		SUMMER CAMPS - BOYS	8,699.50	0.00	0.00	0.00	0.00	8,699.50	100.00
Activity Fund		SUMMER CAMPS - BOYS	0.00	0.00	0.00	0.00	0.00	0.00	0.00
Activity Fund		SUMMER CAMPS -	0.00	0.00	0.00	0.00	0.00	0.00	0.00
Activity Fund		SUMMER CAMPS - CROSS	1,323.00	0.00	0.00	0.00	0.00	1,323.00	100.00
Activity Fund		SUMMER CAMPS -	13,503.50	0.00	0.00	0.00	0.00	13,503.50	100.00
Activity Fund		SUMMER CAMPS - GIRLS	2,958.50	0.00	0.00	0.00	0.00	2,958.50	100.00
Activity Fund		SUMMER CAMPS - GIRLS	107.68	0.00	0.00	0.00	-9,745.50	9,853.18	9,150.43
Activity Fund		SUMMER CAMPS - POMS	0.00	0.00	0.00	0.00	0.00	0.00	0.00
Activity Fund		SUMMER CAMPS -	540.00	0.00	0.00	0.00	100.00	440.00	81.48
Activity Fund		SUMMER CAMPS -	1,896.00	0.00	0.00	0.00	0.00	1,896.00	100.00
Activity Fund		SUMMER CAMPS - TENNIS	1,008.00	0.00	0.00	0.00	0.00	1,008.00	112.00.00
Activity Fund		SUMMER CAMPS -	0.00	0.00	0.00	0.00	0.00	0.00	0.00
Activity Fund		ACTIVITIES - POP	4,526.20	1,152.83	0.00	0.00	-2,399.46	6,925.66	153.01
Activity Fund		ACTIVITIES - ART CLUB	0.00	0.00	0.00	0.00	0.00	0.00	0.00
Activity Fund		ACTIVITIES - ATHLETIC	0.00	0.00	0.00	0.00	0.00	0.00	0.00
Activity Fund		ACTIVITIES - BAND	0.00	282.56	0.00	0.00	-18,308.55	18,308.55	0.00
Activity Fund		ACTIVITIES - CHESS	0.00	0.00	0.00	0.00	-416.00	416.00	0.00
Activity Fund		ACTIVITIES - CHOIR	0.00	0.00	0.00	0.00	0.00	0.00	0.00
Activity Fund		ACTIVITIES - CHORUS	1,248.00	0.00	0.00	0.00	1,248.00	0.00	0.00
Activity Fund		ACTIVITIES - CLASS OF	0.00	0.00	0.00	0.00	0.00	0.00	0.00
Activity Fund		ACTIVITIES - CLASS OF	0.00	0.00	0.00	0.00	0.00	0.00	0.00
Activity Fund		ACTIVITIES - CLASS OF	3,803.35	0.00	0.00	0.00	3,730.91	72.44	1.90
Activity Fund		ACTIVITIES - CLASS OF	1,975.00	0.00	0.00	0.00	1,339.56	635.44	32.17
Activity Fund		ACTIVITIES - CLASS OF	509.00	0.00	0.00	0.00	-1,733.40	2,242.40	440.55

Expenditure Report

Fiscal Year: 2021-2022
Month: March

COUNTY OF GRUNDY SCHOOL DIST 111

Fund Description	Account	Account Description	Revised Budget	MTD Activity	Encumbrance	Pending Activity	Available Funds	Year to Date Activity	Percent of Budget Used
Activity Fund		ACTIVITIES - CLASS OF	20.00	597.63	0.00	0.00	-859.95	879.95	4,399.75
Activity Fund		ACTIVITIES - COMMUNITY	0.00	0.00	0.00	0.00	0.00	0.00	0.00
Activity Fund		ACTIVITIES - CULINARY	0.00	-60.66	0.00	0.00	60.66	-60.66	0.00
Activity Fund		ACTIVITIES - DEBATE	0.00	0.00	0.00	0.00	0.00	0.00	0.00
Activity Fund		ACTIVITIES - DREAM	0.00	0.00	0.00	0.00	0.00	0.00	0.00
Activity Fund		ACTIVITIES - FASHION	0.00	0.00	0.00	0.00	0.00	0.00	0.00
Activity Fund		ACTIVITIES - FCCLA	0.00	0.00	0.00	0.00	-60.00	60.00	0.00
Activity Fund		ACTIVITIES - FFA	121.78	-120.00	0.00	0.00	-1,181.02	1,302.80	1,069.80
Activity Fund		ACTIVITIES - FRENCH NHS	0.00	0.00	0.00	0.00	0.00	0.00	0.00
Activity Fund		ACTIVITIES - FUTURE	0.00	0.00	0.00	0.00	0.00	0.00	0.00
Activity Fund		ACTIVITIES - I.O.T.A.	30.00	0.00	0.00	0.00	-311.00	341.00	11,436.67
Activity Fund		ACTIVITIES - INDIAN	1,219.06	0.00	0.00	0.00	1,219.06	0.00	0.00
Activity Fund		ACTIVITIES - INDIAN	0.00	0.00	0.00	0.00	0.00	0.00	0.00
Activity Fund		ACTIVITIES - INT'L CLUB	481.53	568.29	0.00	0.00	-6,122.23	6,603.76	1,371.41
Activity Fund		ACTIVITIES - INT'L	586.44	1,663.40	0.00	0.00	-5,095.96	5,682.40	968.97
Activity Fund		ACTIVITIES - INTERACT	32.65	0.00	0.00	0.00	-6.77	39.42	120.74
Activity Fund		ACTIVITIES - INVESTMENT	0.00	0.00	0.00	0.00	0.00	0.00	0.00
Activity Fund		ACTIVITIES - JUDO	105.00	0.00	0.00	0.00	105.00	0.00	0.00
Activity Fund		ACTIVITIES -	0.00	0.00	0.00	0.00	0.00	0.00	0.00
Activity Fund		ACTIVITIES - MAC	6,647.33	3,124.41	0.00	0.00	-4,081.23	10,728.56	161.40
Activity Fund		ACTIVITIES - MATH TEAM	0.00	0.00	0.00	0.00	-224.00	224.00	0.00
Activity Fund		ACTIVITIES - MCHS BOOK	0.00	0.00	0.00	0.00	0.00	0.00	0.00
Activity Fund		ACTIVITIES - MEMORIAL	0.00	0.00	0.00	0.00	0.00	0.00	0.00
Activity Fund		ACTIVITIES - MUSICAL	88.36	41.95	0.00	83.46	-57.78	62.68	70.94

Expenditure Report

Fiscal Year: 2021-2022
Month: March

COUNTY OF GRUNDY SCHOOL DIST 111

Fund Description	Account	Account Description	Revised Budget	MTD Activity	Encumbrance	Pending Activity	Available Funds	Year to Date Activity	Percent of Budget Used
Activity Fund		ACTIVITIES - NEEDY	766.16	0.00	0.00	0.00	-61.69	827.85	108.05
Activity Fund		ACTIVITIES - NHS	4,720.00	1,673.02	0.00	0.00	-1,255.99	5,975.99	126.61
Activity Fund		ACTIVITIES - ORCHESIS	2,750.00	0.00	0.00	0.00	0.00	2,750.00	100.00
Activity Fund		ACTIVITIES - PAC	0.00	0.00	0.00	0.00	117.07	-117.07	0.00
Activity Fund		ACTIVITIES - PERCUSSION	1,500.00	8,555.05	1,217.62	0.00	-21,376.70	21,659.08	1,443.94
Activity Fund		ACTIVITIES - POKEMON	0.00	0.00	0.00	0.00	0.00	0.00	0.00
Activity Fund		ACTIVITIES - NEWSPAPER	0.00	0.00	0.00	0.00	-442.00	442.00	0.00
Activity Fund		ACTIVITIES - SADD	0.00	0.00	0.00	0.00	0.00	0.00	0.00
Activity Fund		ACTIVITIES - SCHOLASTIC	0.00	0.00	0.00	99.73	-192.67	92.94	0.00
Activity Fund		ACTIVITIES - SPANISH NHS	377.58	0.00	0.00	0.00	117.58	260.00	68.86
Activity Fund		ACTIVITIES - SPEECH	150.00	0.00	0.00	0.00	23.60	126.40	11484.27
Activity Fund		ACTIVITIES - STUDENT	30,000.00	1,278.86	0.00	0.00	-1,569.53	31,569.53	105.23
Activity Fund		ACTIVITIES - TSA	785.00	0.00	0.00	0.00	-1,627.90	2,412.90	307.38
Activity Fund		ACTIVITIES -	0.00	231.00	0.00	0.00	-1,108.25	1,108.25	0.00
Activity Fund		ACTIVITIES -	180.00	5,843.84	0.00	0.00	-17,797.13	17,977.13	9,987.29
Activity Fund		ACTIVITIES - WYSE	0.00	0.00	0.00	0.00	0.00	0.00	0.00
Activity Fund		ACTIVITIES - YEARBOOK	2,584.45	0.00	0.00	0.00	832.97	1,751.48	67.77
Activity Fund		COADY SCHOLARSHIP	0.00	0.00	0.00	0.00	0.00	0.00	0.00
Activity Fund		CYBRARY	0.00	0.00	0.00	0.00	0.00	0.00	0.00
Activity Fund		FACULTY POP	0.00	0.00	0.00	0.00	-762.56	762.56	0.00
Activity Fund		PROJECT INDIAN	0.00	0.00	0.00	0.00	0.00	0.00	0.00
Activity Fund		PROM	7,421.25	0.00	0.00	0.00	7,421.25	0.00	0.00
Activity Fund		SCHOLARSHIP	36,000.00	0.00	0.00	0.00	-1,500.00	37,500.00	104.17
Activity Fund		TV PRODUCTION	0.00	0.00	0.00	0.00	0.00	0.00	0.00

Expenditure Report

Fiscal Year: 2021-2022
Month: March

COUNTY OF GRUNDY SCHOOL DIST 111

Fund Description	Account	Account Description	Revised Budget	MTD Activity	Encumbrance	Pending Activity	Available Funds	Year to Date Activity	Percent of Budget Used
Activity Fund		ASL - AMERICAN SIGN	0.00	0.00	0.00	0.00	0.00	0.00	0.00
Activity Fund	1119997062	GREEN HOUSE	0.00	0.00	0.00	0.00	-756.25	756.25	0.00
Activity Fund	1119997063	CLASS OF 2025	0.00	587.25	0.00	0.00	-522.80	522.80	0.00
Activity Fund		COADY SCHOLARSHIP	12,500.00	0.00	0.00	0.00	0.00	12,500.00	100.00
11 - -----			293,680.40	51,680.40	38,151.49	7,177.86	-153,106.98	401,458.03	
1 - -----			36,342,028.17	2,817,975.10	543,052.73	323,959.77	8,994,910.56	26,480,105.11	
Operations & Maint		DIST 111 GROUP MEDICAL	66,450.00	4,742.98	0.00	0.00	-27,961.61	94,411.61	142.08
Operations & Maint		DIST 111 GROUP DENTAL	5,800.00	270.05	0.00	0.00	576.26	5,223.74	90.06
Operations & Maint			0.00	0.00	0.00	0.00	0.00	0.00	0.00
Operations & Maint	22310200	BOARD OF ED-OTHER	0.00	0.00	0.00	0.00	0.00	0.00	0.00
Operations & Maint	22510110	CSBO SALARY	57,952.56	4,829.38	0.00	0.00	14,488.14	43,464.42	11575.00
Operations & Maint	22510211	CSBO TRS	0.00	0.00	0.00	0.00	0.00	0.00	0.00
Operations & Maint		20 E 2510 2120 00 300	0.00	227.56	0.00	0.00	-1,114.41	1,114.41	0.00
Operations & Maint	20-2510-	CSBO SALARY (GTL)	0.00	0.00	0.00	0.00	0.00	0.00	0.00
Operations & Maint	22510222	CSBO GROUP INS	8,948.40	745.70	0.00	0.00	2,237.10	6,711.30	75.00
Operations & Maint		CSBO DENTAL INS	469.44	40.18	0.00	0.00	114.18	355.26	75.68
Operations & Maint	22510332	CSBO MILEAGE	0.00	0.00	0.00	0.00	0.00	0.00	0.00
Operations & Maint	22510640	CSBO DUES/CLINICS	0.00	0.00	0.00	0.00	0.00	0.00	0.00
Operations & Maint	22540100	DIR OF BUILDING/GROUND	0.00	0.00	0.00	0.00	0.00	0.00	0.00
Operations & Maint	22540110	CUSTODIANS SALARY	650,000.00	51,083.09	0.00	0.00	195,539.16	454,460.84	69.92
Operations & Maint	22540111	CUSTODIAN SALARY S.C.	31,190.40	0.00	0.00	0.00	25,782.75	5,407.65	17.34
Operations & Maint	22540130	CUSTODIAN OVERTIME	30,000.00	1,878.04	0.00	0.00	18,772.53	11,227.47	37.42
Operations & Maint	22540131	BUILDING EXTRA PAY	0.00	0.00	0.00	0.00	0.00	0.00	0.00
Operations & Maint	20-2540-	CUSTODIANS SALARY (IC)	0.00	0.00	0.00	0.00	0.00	0.00	0.00

Expenditure Report

Fiscal Year: 2021-2022
Month: March

COUNTY OF GRUNDY SCHOOL DIST 111

Fund Description	Account	Account Description	Revised Budget	MTD Activity	Encumbrance	Pending Activity	Available Funds	Year to Date Activity	Percent of Budget Used
Operations & Maint	22540222	CUSTODIAN GROUP INS	363.60	4.46	0.00	0.00	2,526.43	-2,162.83	-594.84
Operations & Maint		CUSTODIAN GROUP INS	197,662.32	14,994.68	0.00	0.00	55,847.84	141,814.48	71.75
Operations & Maint	20-2540-	CUSTODIAN GROUP INS	0.00	0.00	0.00	0.00	0.00	0.00	0.00
Operations & Maint		CUSTODIAN DENTAL	5,740.80	491.14	0.00	0.00	1,551.14	4,189.66	72.98
Operations & Maint	22540300	WAN PURCHASE SERV	0.00	0.00	0.00	0.00	0.00	0.00	0.00
Operations & Maint	22540301	BLDG CONTRACT SERV	35,000.00	0.00	0.00	0.00	32,822.76	2,177.24	6.22
Operations & Maint	22540302	HVAC - CENTRAL	65,000.00	0.00	14,923.00	0.00	47,613.20	2,463.80	3.79
Operations & Maint	22540303	LAWN CARE	15,000.00	0.00	0.00	0.00	15,000.00	0.00	0.00
Operations & Maint	22540304	SNOW REMOVAL -	25,000.00	8,405.82	0.00	0.00	10,692.08	14,307.92	57.23
Operations & Maint	22540305	EXTERMINATING FEES -	2,000.00	272.50	0.00	0.00	162.50	1,837.50	91.88
Operations & Maint	225403022	HVAC - SOUTH	70,000.00	1,176.00	0.00	6,148.00	51,384.89	12,467.11	11617.81
Operations & Maint	225403032	LAWN CARE - SOUTH	5,000.00	0.00	0.00	0.00	4,961.01	38.99	0.78
Operations & Maint	225403042	SNOW REMOVAL - SOUTH	25,000.00	9,326.83	0.00	0.00	6,893.90	18,106.10	72.42
Operations & Maint	225403052	EXTERMINATING FEES -	2,500.00	180.00	0.00	0.00	915.00	1,585.00	63.40
Operations & Maint	22540310	CUSTODIAN HEALTH	0.00	0.00	0.00	0.00	0.00	0.00	0.00
Operations & Maint	22540311	CUSTODIAN LICENSE	0.00	0.00	0.00	0.00	0.00	0.00	0.00
Operations & Maint	22540318	A & E FEES	0.00	0.00	0.00	0.00	0.00	0.00	0.00
Operations & Maint	22540321	DISTRICT OFFICE LEASE	0.00	0.00	0.00	0.00	0.00	0.00	0.00
Operations & Maint	22540320	PROJ IND LEASE	22,000.00	1,660.80	0.00	1,660.80	5,392.00	14,947.20	67.94
Operations & Maint	225403211	GARBAGE - CENTRAL	35,000.00	3,635.02	0.00	0.00	-2,205.30	37,205.30	106.30
Operations & Maint	225403212	GARBAGE - SOUTH	46,000.00	5,688.14	0.00	0.00	475.38	45,524.62	98.97
Operations & Maint	22540322	PCU LEASES	0.00	0.00	0.00	0.00	0.00	0.00	0.00
Operations & Maint	22540323	BLDG REPAIR/MAINT	60,000.00	15,202.56	3,699,885.63	16,963.38	-3,846,418.75	189,569.74	315.95
Operations & Maint	22540324	HVAC REPAIRS - CENTRAL	0.00	2,236.49	0.00	133.72	-28,829.61	28,695.89	0.00

Expenditure Report

Fiscal Year: 2021-2022
Month: March

COUNTY OF GRUNDY SCHOOL DIST 111

Fund Description	Account	Account Description	Revised Budget	MTD Activity	Encumbrance	Pending Activity	Available Funds	Year to Date Activity	Percent of Budget Used
Operations & Maint	225403232	BLDG REPAIR/MAINT	85,000.00	0.00	0.00	2,429.58	69,940.15	12,630.27	14.86
Operations & Maint	225403242	HVAC REPAIRS - SOUTH	0.00	0.00	0.00	1,068.00	-35,003.87	33,935.87	0.00
Operations & Maint	22540332	CUSTODIAN MILEAGE	1,000.00	0.00	0.00	0.00	1,000.00	0.00	0.00
Operations & Maint	22540340	DISTRICT OFF UTILITIES	0.00	0.00	0.00	0.00	0.00	0.00	0.00
Operations & Maint	22540342	PHONE	68,094.89	1,862.17	18,683.00	0.00	-5,813.59	55,225.48	81.10
Operations & Maint	22540341	PROJ INDIAN UTILITIES	2,200.00	138.37	0.00	248.01	-528.80	2,480.79	112.76
Operations & Maint	22540370	WATER-SEWER SERVICES	22,000.00	311.25	0.00	1,782.98	7,534.41	12,682.61	57.65
Operations & Maint	225403702	WATER-SEWER SOUTH	25,000.00	2,417.20	0.00	0.00	-16,822.11	41,822.11	167.29
Operations & Maint	22540380	UNEMPLOY INSURANCE	0.00	0.00	0.00	0.00	0.00	0.00	0.00
Operations & Maint	22540381	WORKERS COMP	0.00	0.00	0.00	0.00	0.00	0.00	0.00
Operations & Maint	22540382	BLDG FLEET INSURANCE	0.00	0.00	0.00	0.00	0.00	0.00	117 0.00
Operations & Maint	22540391	BLDG SECURITY PUR	0.00	0.00	0.00	0.00	0.00	0.00	0.00
Operations & Maint	225403902	CONTRACT SERV S.C.	60,000.00	3,092.24	0.00	425.00	-1,332.07	60,907.07	101.51
Operations & Maint	225403903	SOUTH MAINTENANCE	810,000.00	53,078.00	0.00	53,078.00	279,020.00	477,902.00	59.00
Operations & Maint	225403912	BLDG SECURITY PS	0.00	0.00	0.00	0.00	0.00	0.00	0.00
Operations & Maint	22540392	PRECISION CONTROL -	0.00	0.00	0.00	0.00	0.00	0.00	0.00
Operations & Maint	225403932	SOUTH SITE CROP	0.00	0.00	0.00	0.00	0.00	0.00	0.00
Operations & Maint	22540410	BUILDING SUPPLIES	175,000.00	8,831.44	586.05	8,065.95	96,093.26	70,254.74	40.15
Operations & Maint	22540411	GROUND SUPPLIES	35,000.00	5,963.57	877.46	1,472.23	-19,673.69	52,324.00	149.50
Operations & Maint	225404102	BLDG SUPPLIES SOUTH	25,000.00	7,574.72	96.40	3,417.91	-30,851.41	52,337.10	209.35
Operations & Maint	225404122	SOUTH SITE CROP	12,000.00	0.00	0.00	0.00	4,490.88	7,509.12	62.58
Operations & Maint	22540465	NATURAL GAS	120,000.00	14,073.34	0.00	1,550.84	78,258.65	40,190.51	33.49
Operations & Maint	225404652	NATURAL GAS SOUTH	60,000.00	9,171.19	0.00	0.00	31,521.55	28,478.45	47.46
Operations & Maint	22540466	ELECTRICITY	225,000.00	23,071.69	0.00	20.93	45,492.93	179,486.14	79.77

Expenditure Report

Fiscal Year: 2021-2022
Month: March

COUNTY OF GRUNDY SCHOOL DIST 111

Fund Description	Account	Account Description	Revised Budget	MTD Activity	Encumbrance	Pending Activity	Available Funds	Year to Date Activity	Percent of Budget Used
Operations & Maint	225404662	ELECTRICITY SOUTH	315,000.00	26,308.85	0.00	25,823.36	58,959.71	230,216.93	73.08
Operations & Maint	22540490	911 SOFTWARE	0.00	0.00	0.00	0.00	0.00	0.00	0.00
Operations & Maint	2254049001	ESSER I GRANT SUPPLIES	0.00	0.00	0.00	0.00	0.00	0.00	0.00
Operations & Maint	2254049002	ESSER II GRANT SUPPLIES	0.00	0.00	0.00	0.00	0.00	0.00	0.00
Operations & Maint	2254049003	ESSER III GRANT	0.00	0.00	0.00	0.00	0.00	0.00	0.00
Operations & Maint	22540541	BLDG EQUIPMENT	55,000.00	0.00	27,754.36	0.00	15,677.08	11,568.56	21.03
Operations & Maint	22540542	WAN EQUIPMENT	0.00	0.00	0.00	0.00	0.00	0.00	0.00
Operations & Maint	22540540	PROJ IND EQUIP	2,500.00	0.00	0.00	0.00	2,500.00	0.00	0.00
Operations & Maint	225405412	BLDG EQUIPMENT SOUTH	15,000.00	0.00	0.00	0.00	13,161.28	1,838.72	12.26
Operations & Maint	22540640	CUSTODIAN CLINIC	500.00	0.00	0.00	0.00	500.00	0.00	0.00
Operations & Maint	22540690	REAL ESTATE TAXES-	3,600.00	0.00	0.00	0.00	1,654.05	1,945.95	11854.05
Operations & Maint	2254070001	ESSER II GRANT	281,358.00	0.00	0.00	0.00	281,358.00	0.00	0.00
Operations & Maint	2254070003	ESSER III GRANT	830,062.00	0.00	0.00	0.00	830,062.00	0.00	0.00
Operations & Maint	22541120	SUMMER CUSTODIAN	35,000.00	0.00	0.00	0.00	26,307.25	8,692.75	24.84
Operations & Maint	22541390	BLDG SECURITY	0.00	0.00	0.00	0.00	0.00	0.00	0.00
Operations & Maint	22541391	BLDG SECURITY/PUR	40,000.00	0.00	0.00	0.00	40,000.00	0.00	0.00
Operations & Maint	225413902	BLDG SECURITY CS	0.00	0.00	0.00	0.00	0.00	0.00	0.00
Operations & Maint	225413912	BLDG SECURITY PS	0.00	0.00	0.00	0.00	0.00	0.00	0.00
Operations & Maint	22541410	BLDG SECURITY SUPPLIES	20,000.00	0.00	0.00	0.00	20,000.00	0.00	0.00
Operations & Maint	225414102	BLDG SECURITY SUPPLY S	0.00	0.00	0.00	0.00	0.00	0.00	0.00
Operations & Maint	22541540	BLDG SECURITY	150,000.00	74,721.04	2,045.00	3,675.00	-1,339.04	145,619.04	97.08
Operations & Maint	225415402	BLDG SECURITY EQ	25,000.00	0.00	0.00	0.00	25,000.00	0.00	0.00
Operations & Maint	22542530	SITE IMPROVEMENT	50,000.00	0.00	0.00	0.00	50,000.00	0.00	0.00
Operations & Maint	22542531	BLDG IMPROVEMENT	0.00	0.00	0.00	0.00	0.00	0.00	0.00

Expenditure Report

Fiscal Year: 2021-2022
Month: March

COUNTY OF GRUNDY SCHOOL DIST 111

Fund Description	Account	Account Description	Revised Budget	MTD Activity	Encumbrance	Pending Activity	Available Funds	Year to Date Activity	Percent of Budget Used
Operations & Maint	225425302	SITE IMPROVEMNT SOUTH	20,000.00	0.00	0.00	0.00	20,000.00	0.00	0.00
Operations & Maint	225425312	BLDG IMPROVEMNT	20,000.00	0.00	0.00	0.00	11,432.51	8,567.49	42.84
Operations & Maint	22543540	ATHLETIC FIELDS	75,000.00	0.00	0.00	0.00	71,097.24	3,902.76	5.20
Operations & Maint	2380600	COMMERCIAL LIAB	0.00	0.00	0.00	0.00	0.00	0.00	0.00
Operations & Maint	24140520	GAVC-BUILDING COSTS	0.00	0.00	0.00	0.00	0.00	0.00	0.00
Operations & Maint	24140600	GAVC BUILD EXPENSES	380,000.00	53,012.91	0.00	0.00	121,432.34	258,567.66	68.04
Operations & Maint	24140620	GAVC CTE PROGRAMS	0.00	0.00	0.00	0.00	0.00	0.00	0.00
Operations & Maint	20-481-222-	IMRF (BMF 3000)	0.00	0.00	0.00	0.00	0.00	0.00	0.00
Operations & Maint	20-481-222-	IMRF (BMF 3000)	0.00	0.00	0.00	0.00	0.00	0.00	0.00
Operations & Maint	28130	TRANS TO TORT	0.00	0.00	0.00	0.00	0.00	0.00	0.00
Operations & Maint	28400	TRANS TO B & I	0.00	0.00	0.00	0.00	0.00	0.00	119 0.00
Operations & Maint	28800660	TRANS TO CAPITOL	0.00	0.00	0.00	0.00	0.00	0.00	0.00
20 - -----			5,505,392.41	410,719.40	3,764,850.90	127,963.69	-1,321,652.72	2,934,230.54	
2 - -----			5,505,392.41	410,719.40	3,764,850.90	127,963.69	-1,321,652.72	2,934,230.54	
Debt Service Fund or	34190690	DEVELOPMENT	0.00	0.00	0.00	0.00	0.00	0.00	0.00
Debt Service Fund or	35140620	INTEREST ON BONDS-2001	0.00	0.00	0.00	0.00	0.00	0.00	0.00
Debt Service Fund or	35140621	INTEREST ON BONDS-1999	0.00	0.00	0.00	0.00	0.00	0.00	0.00
Debt Service Fund or	35140622	INTEREST ON BONDS-2005	0.00	0.00	0.00	0.00	0.00	0.00	0.00
Debt Service Fund or	35140623	INTEREST ON CONST	0.00	0.00	0.00	0.00	0.00	0.00	0.00
Debt Service Fund or	35140624	INTEREST ON VAR RATE	0.00	0.00	0.00	0.00	0.00	0.00	0.00
Debt Service Fund or	35140626	INTEREST ON BONDS-2008	0.00	0.00	0.00	0.00	0.00	0.00	0.00
Debt Service Fund or	35140627	INTEREST ON BONDS 2010	0.00	0.00	0.00	0.00	0.00	0.00	0.00
Debt Service Fund or	35140628	INTEREST ON BONDS -	0.00	0.00	0.00	0.00	0.00	0.00	0.00
Debt Service Fund or	35140629	INTEREST ON BONDS	0.00	0.00	0.00	0.00	0.00	0.00	0.00

Expenditure Report

Fiscal Year: 2021-2022
Month: March

COUNTY OF GRUNDY SCHOOL DIST 111

Fund Description	Account	Account Description	Revised Budget	MTD Activity	Encumbrance	Pending Activity	Available Funds	Year to Date Activity	Percent of Budget Used
Debt Service Fund or	35140630	INTEREST ON BONDS	284,100.00	0.00	0.00	0.00	142,050.00	142,050.00	50.00
Debt Service Fund or	35140625	APPLE LEASE INTEREST	0.00	0.00	0.00	0.00	0.00	0.00	0.00
Debt Service Fund or	35140631	INTEREST ON BONDS 2014	253,050.00	0.00	0.00	98,175.00	0.00	154,875.00	61.20
Debt Service Fund or	35140632	INTEREST ON BONDS -	0.00	0.00	0.00	0.00	0.00	0.00	0.00
Debt Service Fund or	35140633	INTEREST ON BONDS -	365,200.00	0.00	0.00	182,600.00	0.00	182,600.00	50.00
Debt Service Fund or	35140634	INTEREST ON BONDS-	0.00	0.00	0.00	0.00	0.00	0.00	0.00
Debt Service Fund or	35140635	INTEREST ON BONDS-	238,400.00	0.00	0.00	119,200.00	0.00	119,200.00	50.00
Debt Service Fund or	35140636	INTEREST ON BONDS -	77,800.00	0.00	0.00	0.00	38,900.00	38,900.00	50.00
Debt Service Fund or	35140637	INTEREST ON BONDS 2019	738,550.00	0.00	0.00	0.00	341,125.00	397,425.00	53.81
Debt Service Fund or	35146218	INTEREST ON BONDS 2022	0.00	0.00	0.00	86,600.00	-86,600.00	0.00	0.00
Debt Service Fund or	35200619	BONDS RETIRED 2011	0.00	0.00	0.00	0.00	0.00	0.00	120 0.00
Debt Service Fund or	35200620	BONDS RETIRED 2012A	0.00	0.00	0.00	0.00	0.00	0.00	0.00
Debt Service Fund or	35200621	BONDS RETIRED 2012B	0.00	0.00	0.00	0.00	0.00	0.00	0.00
Debt Service Fund or	35200622	BOND RETIRED THROUGH	0.00	0.00	0.00	0.00	0.00	0.00	0.00
Debt Service Fund or	35200610	BONDS RETIRED 2006B	0.00	0.00	0.00	0.00	0.00	0.00	0.00
Debt Service Fund or	35200611	BOND RETIRED-1999	0.00	0.00	0.00	0.00	0.00	0.00	0.00
Debt Service Fund or	35200612	BONDS RETIRED-2005	0.00	0.00	0.00	0.00	0.00	0.00	0.00
Debt Service Fund or	35200613	BOND RETIRED 2006A	0.00	0.00	0.00	0.00	0.00	0.00	0.00
Debt Service Fund or	35200614	BOND RETIRED 2010	0.00	0.00	0.00	0.00	0.00	0.00	0.00
Debt Service Fund or	35200615	APPLE LEASE PRINCIPAL	0.00	0.00	0.00	0.00	0.00	0.00	0.00
Debt Service Fund or	35200616	BONDS RETIRED - 2001	0.00	0.00	0.00	0.00	0.00	0.00	0.00
Debt Service Fund or	35200617	BONDS RETIRED	0.00	0.00	0.00	0.00	0.00	0.00	0.00
Debt Service Fund or	35200618	BONDS RETIRED 2008	0.00	0.00	0.00	0.00	0.00	0.00	0.00
Debt Service Fund or	35200629	PRINCIPAL ON BONDS	2,815,000.00	0.00	0.00	0.00	0.00	2,815,000.00	100.00

Expenditure Report

Fiscal Year: 2021-2022
Month: March

COUNTY OF GRUNDY SCHOOL DIST 111

Fund Description	Account	Account Description	Revised Budget	MTD Activity	Encumbrance	Pending Activity	Available Funds	Year to Date Activity	Percent of Budget Used
Debt Service Fund or	35200623	INTEREST PAYMENT ON	0.00	0.00	0.00	0.00	0.00	0.00	0.00
Debt Service Fund or	35300624	PRINCIPAL ON BONDS	555,000.00	0.00	0.00	0.00	0.00	555,000.00	100.00
Debt Service Fund or	35300611	BOND PRINCIPAL	0.00	0.00	0.00	0.00	0.00	0.00	0.00
Debt Service Fund or	35300612	COST OF BOND ISSUANCE	0.00	0.00	0.00	0.00	0.00	0.00	0.00
Debt Service Fund or	35300613	PRINCIPAL ON BOND	0.00	0.00	0.00	0.00	0.00	0.00	0.00
Debt Service Fund or	35300614	PRINCIPAL ON BOND 2008	0.00	0.00	0.00	0.00	0.00	0.00	0.00
Debt Service Fund or	35300615	PRINCIPAL ON BOND 2010	0.00	0.00	0.00	0.00	0.00	0.00	0.00
Debt Service Fund or	35300616	PRINCIPAL ON BONDS	0.00	0.00	0.00	0.00	0.00	0.00	0.00
Debt Service Fund or	35300617	PRINCIPAL ON BONDS	0.00	0.00	0.00	0.00	0.00	0.00	0.00
Debt Service Fund or	35300618	PRINCIPAL ON BONDS	0.00	0.00	0.00	0.00	0.00	0.00	0.00
Debt Service Fund or	35300619	PRINCIPAL ON BONDS	2,835,000.00	0.00	0.00	0.00	0.00	2,835,000.00	100.00
Debt Service Fund or	35300620	PRINCIPAL ON BONDS	0.00	0.00	0.00	0.00	0.00	0.00	0.00
Debt Service Fund or	35300621	PRINCIPAL ON BONDS	0.00	0.00	0.00	0.00	0.00	0.00	0.00
Debt Service Fund or	35300622	PRINCIPAL ON BONDS	0.00	0.00	0.00	0.00	0.00	0.00	0.00
Debt Service Fund or	35300623	PRINCIPAL ON BONDS	335,000.00	0.00	0.00	335,000.00	0.00	0.00	0.00
Debt Service Fund or	3530611013	PRINCIPAL ON BONDS	0.00	0.00	0.00	0.00	0.00	0.00	0.00
Debt Service Fund or	35300712	COMPUTER LEASE	0.00	0.00	0.00	0.00	0.00	0.00	0.00
Debt Service Fund or	35300710	PRINTROOM COPIER	0.00	0.00	0.00	0.00	0.00	0.00	0.00
Debt Service Fund or	35300711	OTHER COPIERS LEASE	0.00	0.00	0.00	0.00	0.00	0.00	0.00
Debt Service Fund or	35300714	DISTRICT OFFICE LEASE	0.00	0.00	0.00	0.00	0.00	0.00	0.00
Debt Service Fund or	35300715	PROJECT INDIAN LEASE	0.00	0.00	0.00	0.00	0.00	0.00	0.00
Debt Service Fund or	353007122	PRINTROOM COPIER	0.00	0.00	0.00	0.00	0.00	0.00	0.00
Debt Service Fund or	353007132	OTHER COPIERS LEASE	0.00	0.00	0.00	0.00	0.00	0.00	0.00
Debt Service Fund or	35900318	BOND LEGAL FEES	0.00	0.00	0.00	0.00	0.00	0.00	0.00

Expenditure Report

Fiscal Year: 2021-2022
Month: March

COUNTY OF GRUNDY SCHOOL DIST 111

Fund Description	Account	Account Description	Revised Budget	MTD Activity	Encumbrance	Pending Activity	Available Funds	Year to Date Activity	Percent of Budget Used
Debt Service Fund or	35900319	BOND CLOSING COSTS	0.00	0.00	0.00	0.00	-55,450.00	55,450.00	0.00
Debt Service Fund or	35900320	BOND PREMIUM ESCROW	0.00	0.00	0.00	0.00	0.00	0.00	0.00
Debt Service Fund or	35900390	SERVICE CHARGE	3,050.00	450.00	0.00	0.00	2,100.00	950.00	31.15
Debt Service Fund or	35900391	REMARKETING AGENT	0.00	0.00	0.00	0.00	0.00	0.00	0.00
Debt Service Fund or	35900611	ESCROW ADJUSTMENTS	0.00	0.00	0.00	0.00	0.00	0.00	0.00
Debt Service Fund or	38990000	OTHER MISC FINANCING	0.00	0.00	0.00	0.00	0.00	0.00	0.00
30 - -----			8,500,150.00	450.00	0.00	821,575.00	382,125.00	7,296,450.00	
3- - -----			8,500,150.00	450.00	0.00	821,575.00	382,125.00	7,296,450.00	
Transportation Fund		DIST 111 GROUP MEDICAL	202,721.76	2,443.82	0.00	0.00	45,215.19	157,506.57	77.70
Transportation Fund		DIST 111 GROUP DENTAL	2,943.60	270.15	0.00	0.00	1,402.91	1,540.69	52.34
Transportation Fund	42190110	CSBO SALARY	57,952.32	4,829.36	0.00	0.00	14,488.08	43,464.24	12275.00
Transportation Fund	42190211	CSBO TRS	0.00	0.00	0.00	0.00	0.00	0.00	0.00
Transportation Fund		40 E 2190 2120 00 300	0.00	227.56	0.00	0.00	-1,114.41	1,114.41	0.00
Transportation Fund	40-2190-	CSBO SALARY (GTL)	0.00	0.00	0.00	0.00	0.00	0.00	0.00
Transportation Fund	42190222	CSBO GROUP INS	8,948.64	745.72	0.00	0.00	2,237.16	6,711.48	75.00
Transportation Fund		CSBO DENTAL INS	469.44	40.18	0.00	0.00	114.18	355.26	75.68
Transportation Fund	42190332	CSBO MILEAGE	0.00	0.00	0.00	0.00	0.00	0.00	0.00
Transportation Fund	42190640	CSBO DUES/CLINICS	0.00	0.00	0.00	0.00	0.00	0.00	0.00
Transportation Fund			0.00	0.00	0.00	0.00	0.00	0.00	0.00
Transportation Fund		BKKPER GROUP INS	0.00	0.00	0.00	0.00	0.00	0.00	0.00
Transportation Fund		DIST 111 GROUP DENTAL	0.00	0.00	0.00	0.00	0.00	0.00	0.00
Transportation Fund	42310200	BOARD OF ED-OTHER	0.00	0.00	0.00	0.00	0.00	0.00	0.00
Transportation Fund	42550110	TRANS SECY SALARY	70,000.00	4,444.11	0.00	0.00	29,393.21	40,606.79	58.01
Transportation Fund	42550111	GAVC/PREMIER ROUTE	0.00	0.00	0.00	0.00	0.00	0.00	0.00

Expenditure Report

Fiscal Year: 2021-2022
Month: March

COUNTY OF GRUNDY SCHOOL DIST 111

Fund Description	Account	Account Description	Revised Budget	MTD Activity	Encumbrance	Pending Activity	Available Funds	Year to Date Activity	Percent of Budget Used
Transportation Fund	42550112	OUT OF DISTRICT ROUTE	375,000.00	38,100.90	0.00	0.00	38,387.92	336,612.08	89.76
Transportation Fund	42550113	REGULAR ROUTE SALARY	475,000.00	47,141.69	0.00	0.00	54,278.67	420,721.33	88.57
Transportation Fund	42550114	BKKPER TRANS SALARY	6,614.88	551.24	0.00	0.00	1,653.72	4,961.16	75.00
Transportation Fund	42550115	OUT OF DISTRICT BUS	75,000.00	4,620.34	0.00	0.00	27,575.75	47,424.25	63.23
Transportation Fund	42550116	SHUTTLE(S)	0.00	0.00	0.00	0.00	0.00	0.00	0.00
Transportation Fund	42550117	BUS SUBS 201 FOR 111	0.00	0.00	0.00	0.00	0.00	0.00	0.00
Transportation Fund	42550118	IDEA PART B SP ED BUS	0.00	0.00	0.00	0.00	0.00	0.00	0.00
Transportation Fund	42550119	FULL TIME DRIVER	65,000.00	6,754.08	0.00	0.00	13,342.55	51,657.45	79.47
Transportation Fund	42550130	EXTRA DUTY (non-drive)	82,065.12	1,673.09	0.00	0.00	62,568.89	19,496.23	23.76
Transportation Fund	42550131	ACADEMIC TRIP(S)	10,000.00	3,883.54	0.00	0.00	-17,699.93	27,699.93	277.00
Transportation Fund	42550132	ATHLETIC/ACTIVITES	40,000.00	4,549.87	0.00	0.00	-17,083.25	57,083.25	12442.71
Transportation Fund	42550133	ACTIVITIES TRIP	0.00	0.00	0.00	0.00	0.00	0.00	0.00
Transportation Fund	42550223	TRANS SEC INSURANCE	600.00	0.00	0.00	0.00	600.00	0.00	0.00
Transportation Fund	42554223	TRANS. DIR. INSURANCE	0.00	0.00	0.00	0.00	0.00	0.00	0.00
Transportation Fund	40-2550-	TRANSPORTATION	16,949.76	3,629.50	0.00	0.00	1,062.02	15,887.74	93.73
Transportation Fund		FT BUS DRIVER GROUP	0.00	0.00	0.00	0.00	-348.47	348.47	0.00
Transportation Fund		40 E 2550 2220 00 300	0.00	0.00	0.00	0.00	-0.38	0.38	0.00
Transportation Fund		BKKPER TRANS GROUP	852.00	71.00	0.00	0.00	213.00	639.00	75.00
Transportation Fund		BUS DRIVER GROUP INS	8,363.28	696.94	0.00	0.00	-12,234.92	20,598.20	246.29
Transportation Fund		TRANS SEC DENTAL INS	441.60	37.78	0.00	0.00	107.46	334.14	75.67
Transportation Fund		BKKPER DENTAL INS	44.16	3.78	0.00	0.00	10.74	33.42	75.68
Transportation Fund	42550230	COURSE	0.00	0.00	0.00	0.00	0.00	0.00	0.00
Transportation Fund	42550310	TRANS HEALTH EXAMS	2,000.00	0.00	0.00	681.00	-5,254.25	6,573.25	328.66
Transportation Fund	42551310	TANK TESTING	0.00	0.00	0.00	0.00	0.00	0.00	0.00

Expenditure Report

Fiscal Year: 2021-2022
Month: March

COUNTY OF GRUNDY SCHOOL DIST 111

Fund Description	Account	Account Description	Revised Budget	MTD Activity	Encumbrance	Pending Activity	Available Funds	Year to Date Activity	Percent of Budget Used
Transportation Fund	42550320	BUS LEASES	350,000.00	0.00	0.00	0.00	143,513.18	206,486.82	59.00
Transportation Fund	42550321	GARBAGE DISPOSAL	5,500.00	1,310.27	0.00	0.00	-189.73	5,689.73	103.45
Transportation Fund	42550322	CLEANING SERVICES	5,000.00	0.00	0.00	0.00	1,588.52	3,411.48	68.23
Transportation Fund	42551322	SNOW REMOVAL-BUS	11,000.00	7,720.70	0.00	0.00	-3,005.09	14,005.09	127.32
Transportation Fund	42550331	SPECIAL ED TRANS	10,000.00	0.00	0.00	0.00	10,000.00	0.00	0.00
Transportation Fund	42550332	TRANS MILEAGE	2,500.00	117.00	0.00	277.04	1,515.19	707.77	28.31
Transportation Fund	42550340	PHONE-BUS GARAGE	2,500.00	42.12	0.00	0.00	1,833.38	666.62	26.66
Transportation Fund	42551340	TRANS POSTAGE	0.00	0.00	0.00	0.00	0.00	0.00	0.00
Transportation Fund	42550350	TRANS ADVERTISING	500.00	0.00	0.00	0.00	500.00	0.00	0.00
Transportation Fund	42550370	WATER-BUS GARAGE	2,500.00	115.40	0.00	55.21	1,798.87	645.92	25.84
Transportation Fund	42550380	UNEMPLOY INSURANCE	0.00	0.00	0.00	0.00	0.00	0.00	124 0.00
Transportation Fund	42550381	WORKERS COMP	0.00	0.00	0.00	0.00	0.00	0.00	0.00
Transportation Fund	42550382	BUS FLEET INSURANCE	0.00	0.00	0.00	0.00	0.00	0.00	0.00
Transportation Fund	42550390	MECHANICS	0.00	0.00	0.00	0.00	0.00	0.00	0.00
Transportation Fund	42550391	ROUTING SOFTWARE	4,000.00	0.00	0.00	0.00	951.47	3,048.53	76.21
Transportation Fund	42550464	VAN GAS & SUPPLIES	15,000.00	2,786.11	0.00	2,389.65	-12,491.06	25,101.41	167.34
Transportation Fund	42550640	TRANS DIR	600.00	100.00	0.00	0.00	-2,017.75	2,617.75	436.29
Transportation Fund	42550690	REFUND ACCOUNT	0.00	0.00	0.00	0.00	0.00	0.00	0.00
Transportation Fund	42552410	BUS SUPPLIES	25,000.00	1,315.38	0.00	1,894.51	15,687.86	7,417.63	29.67
Transportation Fund	42552411	MECH/CUST SUPPLIES	5,000.00	-27.86	0.00	356.88	3,611.68	1,031.44	20.63
Transportation Fund	42552464	BUS FUEL	100,000.00	27,962.48	0.00	15,253.45	-82,356.75	167,103.30	167.10
Transportation Fund	42552465	NATURAL GAS-BUS	2,200.00	601.85	0.00	0.00	608.38	1,591.62	72.35
Transportation Fund	42552466	ELECTRICITY-BUS	7,500.00	654.98	0.00	0.00	1,900.11	5,599.89	74.67
Transportation Fund	42554110	BUS MECHANIC SALARY	115,976.64	8,031.24	0.00	0.00	58,948.91	57,027.73	49.17

Expenditure Report

Fiscal Year: 2021-2022
Month: March

COUNTY OF GRUNDY SCHOOL DIST 111

Fund Description	Account	Account Description	Revised Budget	MTD Activity	Encumbrance	Pending Activity	Available Funds	Year to Date Activity	Percent of Budget Used
Transportation Fund	42554111	TRANS DIRECTORS	75,014.16	6,251.18	0.00	0.00	46,437.33	28,576.83	38.10
Transportation Fund	42554222	BUS MECH GROUP INS	55,883.76	4,666.04	0.00	0.00	21,249.54	34,634.22	61.98
Transportation Fund		TRANS DIRECTORS	17,833.68	1,486.14	0.00	0.00	11,084.85	6,748.83	37.84
Transportation Fund		BUS MECH DENTAL INS	883.20	75.56	0.00	0.00	435.72	447.48	50.67
Transportation Fund		TRANS DIRECTOR DENTAL	441.60	37.78	0.00	0.00	328.26	113.34	25.67
Transportation Fund	42554300	TRANS CONTR SERV	5,000.00	823.48	0.00	0.00	125.56	4,874.44	97.49
Transportation Fund	42554323	TRANS REPAIR/MAINT	90,000.00	10,831.89	0.00	3,161.53	5,270.89	81,567.58	90.63
Transportation Fund	42554339	INSPECTION/LICENSE	10,000.00	-128.00	0.00	0.00	-454.39	10,454.39	104.54
Transportation Fund	42554540	TRANS EQUIPMENT	5,000.00	0.00	0.00	0.00	5,000.00	0.00	0.00
Transportation Fund	42554550	TRANS VEHICLES	75,000.00	29,628.00	0.00	0.00	45,372.00	29,628.00	39.50
Transportation Fund	42559520	BUS GARAGE ADDITION	0.00	0.00	0.00	0.00	0.00	0.00	125 0.00
Transportation Fund	42559530	TRANS BLDG IMPROVE	52,068.18	968.80	0.00	0.00	-33,189.46	85,257.64	163.74
Transportation Fund	42559690	TRANS - OTHER	0.00	0.00	0.00	0.00	0.00	0.00	0.00
Transportation Fund	40-481-222-	IMRF (BMF 3000)	0.00	0.00	0.00	0.00	0.00	0.00	0.00
Transportation Fund	40-481-222-	IMRF (BMF 3000)	0.00	0.00	0.00	0.00	0.00	0.00	0.00
40 - -----			2,552,867.78	230,085.19	0.00	24,069.27	482,973.31	2,045,825.20	
4- - -----			2,552,867.78	230,085.19	0.00	24,069.27	482,973.31	2,045,825.20	
I.M.R.F./Soc. Sec. Fund	50-1130-212	TITLE 1 SALARIES	2,000.16	129.56	0.00	0.00	-476.03	2,476.19	123.80
I.M.R.F./Soc. Sec. Fund	51130212	INSTR IMRF	0.00	1,898.19	0.00	0.00	-10,840.92	10,840.92	0.00
I.M.R.F./Soc. Sec. Fund		NURSE IMRF	0.00	43.90	0.00	0.00	-257.50	257.50	0.00
I.M.R.F./Soc. Sec. Fund		DEAN SEC IMRF	0.00	99.02	0.00	0.00	-627.58	627.58	0.00
I.M.R.F./Soc. Sec. Fund		50 E 1130 2120 00 300	0.00	0.00	0.00	0.00	0.00	0.00	0.00
I.M.R.F./Soc. Sec. Fund	5113021250	ATH TRAINER IMRF	0.00	0.00	0.00	0.00	0.00	0.00	0.00
I.M.R.F./Soc. Sec. Fund	50-1130-213	TITLE 1 SALARIES (FR)	1,209.84	81.14	0.00	0.00	-302.62	1,512.46	125.01

Expenditure Report

Fiscal Year: 2021-2022
Month: March

COUNTY OF GRUNDY SCHOOL DIST 111

Fund Description	Account	Account Description	Revised Budget	MTD Activity	Encumbrance	Pending Activity	Available Funds	Year to Date Activity	Percent of Budget Used
I.M.R.F./Soc. Sec. Fund	51130213	INSTR FICA	0.00	1,064.08	0.00	0.00	-5,927.76	5,927.76	0.00
I.M.R.F./Soc. Sec. Fund		NURSE FICA	535.68	27.50	0.00	0.00	292.30	243.38	45.43
I.M.R.F./Soc. Sec. Fund		50 E 1130 2130 00 300	0.00	52.22	0.00	0.00	-327.57	327.57	0.00
I.M.R.F./Soc. Sec. Fund		MONITOR FICA	0.00	0.00	0.00	0.00	0.00	0.00	0.00
I.M.R.F./Soc. Sec. Fund		SEC FICA	0.00	0.00	0.00	0.00	0.00	0.00	0.00
I.M.R.F./Soc. Sec. Fund	5113021305	ENGLISH/DRAMA FICA	0.00	0.00	0.00	0.00	0.00	0.00	0.00
I.M.R.F./Soc. Sec. Fund	5113021312	MUSIC SALARY FICA	0.00	0.00	0.00	0.00	0.00	0.00	0.00
I.M.R.F./Soc. Sec. Fund	5113021321	DRIVER ED FICA	0.00	0.00	0.00	0.00	0.00	0.00	0.00
I.M.R.F./Soc. Sec. Fund	50-1130-	INSTR LEADER SALARY	0.00	0.00	0.00	0.00	0.00	0.00	0.00
I.M.R.F./Soc. Sec. Fund	5113021350	ATH TRAINER FICA	0.00	0.00	0.00	0.00	0.00	0.00	0.00
I.M.R.F./Soc. Sec. Fund	50-1130-214	OVERLOAD (MR)	282.96	18.98	0.00	0.00	-70.78	353.74	126.25.01
I.M.R.F./Soc. Sec. Fund	51130214	INSTR MEDICARE	1,539.12	377.13	0.00	0.00	-1,003.87	2,542.99	165.22
I.M.R.F./Soc. Sec. Fund		INSTR MEDICARE	7,066.80	731.74	0.00	0.00	2,072.62	4,994.18	70.67
I.M.R.F./Soc. Sec. Fund		DEAN MEDICARE	0.00	61.32	0.00	0.00	-503.13	503.13	0.00
I.M.R.F./Soc. Sec. Fund		INSTR MEDICARE	0.00	0.00	0.00	0.00	-4.15	4.15	0.00
I.M.R.F./Soc. Sec. Fund		INSTR MEDICARE	0.00	0.00	0.00	0.00	-340.25	340.25	0.00
I.M.R.F./Soc. Sec. Fund		MEDICARE	0.00	0.00	0.00	0.00	0.00	0.00	0.00
I.M.R.F./Soc. Sec. Fund	5113021402	ART MEDICARE	2,536.80	211.36	0.00	0.00	644.69	1,892.11	74.59
I.M.R.F./Soc. Sec. Fund	5113021405	ENGLISH/DRAMA	23,651.52	2,007.78	0.00	0.00	6,153.52	17,498.00	73.98
I.M.R.F./Soc. Sec. Fund	5113021406	FOREIGN LANG MEDICARE	10,919.52	882.22	0.00	0.00	2,886.64	8,032.88	73.56
I.M.R.F./Soc. Sec. Fund	5113021411	MATH MEDICARE	18,520.08	1,540.58	0.00	0.00	4,508.25	14,011.83	75.66
I.M.R.F./Soc. Sec. Fund	5113021412	MUSIC MEDICARE	3,450.24	287.46	0.00	0.00	810.34	2,639.90	76.51
I.M.R.F./Soc. Sec. Fund	5113021413	NAT SCIENCE MEDICARE	18,809.04	1,563.95	0.00	0.00	4,750.33	14,058.71	74.74
I.M.R.F./Soc. Sec. Fund	5113021415	SOC SCIENCE MEDICARE	17,987.52	1,507.77	0.00	0.00	4,563.40	13,424.12	74.63

Expenditure Report

Fiscal Year: 2021-2022
Month: March

COUNTY OF GRUNDY SCHOOL DIST 111

Fund Description	Account	Account Description	Revised Budget	MTD Activity	Encumbrance	Pending Activity	Available Funds	Year to Date Activity	Percent of Budget Used
I.M.R.F./Soc. Sec. Fund	5113021421	DRIVER ED MEDICARE	0.00	0.00	0.00	0.00	0.00	0.00	0.00
I.M.R.F./Soc. Sec. Fund	5113021427	INSTR LDR MEDICARE	10,642.56	886.18	0.00	0.00	2,851.58	7,790.98	73.21
I.M.R.F./Soc. Sec. Fund	5113021450	PHYS ED MEDICARE	16,161.60	1,338.42	0.00	0.00	4,169.57	11,992.03	74.20
I.M.R.F./Soc. Sec. Fund	50-1200-	IDEA PART B SP ED	0.00	0.00	0.00	0.00	0.00	0.00	0.00
I.M.R.F./Soc. Sec. Fund	50-1200-	IDEA SP ED LOCAL (RM)	0.00	0.00	0.00	0.00	0.00	0.00	0.00
I.M.R.F./Soc. Sec. Fund		SPEC ED AIDE IMRF	11,585.76	995.76	0.00	0.00	3,246.41	8,339.35	71.98
I.M.R.F./Soc. Sec. Fund		SPEC ED SEC IMRF	3,831.60	308.40	0.00	0.00	990.60	2,841.00	74.15
I.M.R.F./Soc. Sec. Fund	50-1200-	IDEA PART B SP ED	0.00	0.00	0.00	0.00	0.00	0.00	0.00
I.M.R.F./Soc. Sec. Fund	50-1200-	IDEA SP ED LOCAL (FR)	0.00	0.00	0.00	0.00	0.00	0.00	0.00
I.M.R.F./Soc. Sec. Fund		SPEC ED AIDE FICA	6,915.12	620.72	0.00	0.00	1,875.09	5,040.03	72.88
I.M.R.F./Soc. Sec. Fund		SPEC ED SEC FICA	2,243.28	186.94	0.00	0.00	560.82	1,682.46	12775.00
I.M.R.F./Soc. Sec. Fund	50-1200-	SPECIAL ED SALARY	17,820.72	1,474.86	0.00	0.00	4,740.41	13,080.31	73.40
I.M.R.F./Soc. Sec. Fund		SPEC ED MEDICARE	0.00	0.00	0.00	0.00	0.00	0.00	0.00
I.M.R.F./Soc. Sec. Fund		SPEC ED AIDE MEDICARE	1,617.36	145.18	0.00	0.00	438.51	1,178.85	72.89
I.M.R.F./Soc. Sec. Fund		SPEC ED SEC MEDICARE	524.64	43.72	0.00	0.00	131.16	393.48	75.00
I.M.R.F./Soc. Sec. Fund	51250212	COOP HOMEBOUND/HOSP	0.00	0.00	0.00	0.00	0.00	0.00	0.00
I.M.R.F./Soc. Sec. Fund	51250213	COOP HOMEBOUND/HOSP	0.00	0.00	0.00	0.00	0.00	0.00	0.00
I.M.R.F./Soc. Sec. Fund	51250214	COOP HB/HOSP	0.00	0.00	0.00	0.00	0.00	0.00	0.00
I.M.R.F./Soc. Sec. Fund	50-1400-	CTE SALARY IMRF	0.00	0.00	0.00	0.00	0.00	0.00	0.00
I.M.R.F./Soc. Sec. Fund	51400213	VOC ED GRANT FICA	0.00	0.00	0.00	0.00	0.00	0.00	0.00
I.M.R.F./Soc. Sec. Fund	51400214	VOC ED GRANT MEDICARE	3,852.00	316.62	0.00	0.00	1,009.56	2,842.44	73.79
I.M.R.F./Soc. Sec. Fund	5140021410	IND TECH MEDICARE	2,622.00	212.77	0.00	0.00	730.30	1,891.70	72.15
I.M.R.F./Soc. Sec. Fund	5140121401	AG MEDICARE	3,263.28	270.64	0.00	0.00	843.93	2,419.35	74.14
I.M.R.F./Soc. Sec. Fund	5140721403	BUSINESS ED MEDICARE	3,131.04	257.67	0.00	0.00	823.01	2,308.03	73.71

Expenditure Report

Fiscal Year: 2021-2022
Month: March

COUNTY OF GRUNDY SCHOOL DIST 111

Fund Description	Account	Account Description	Revised Budget	MTD Activity	Encumbrance	Pending Activity	Available Funds	Year to Date Activity	Percent of Budget Used
I.M.R.F./Soc. Sec. Fund	51410214	VIDEO EDIT MEDICARE	0.00	0.00	0.00	0.00	0.00	0.00	0.00
I.M.R.F./Soc. Sec. Fund	5141121430	INST. TECH MEDICARE	1,127.76	93.96	0.00	0.00	287.49	840.27	74.51
I.M.R.F./Soc. Sec. Fund	51417212	ATHLETIC TRAINER IMRF	5,697.12	458.56	0.00	0.00	1,472.88	4,224.24	74.15
I.M.R.F./Soc. Sec. Fund	51417213	ATHLETIC TRAINER FICA	3,378.48	281.40	0.00	0.00	845.04	2,533.44	74.99
I.M.R.F./Soc. Sec. Fund	51417214	ATHLETIC TRAINER	790.08	65.82	0.00	0.00	197.58	592.50	74.99
I.M.R.F./Soc. Sec. Fund	5142021409	FAM/CONS SCI MEDICARE	2,867.28	239.80	0.00	0.00	812.13	2,055.15	71.68
I.M.R.F./Soc. Sec. Fund	50-1500-212	INVITATIONAL WKRS (RM)	0.00	0.00	0.00	0.00	0.00	0.00	0.00
I.M.R.F./Soc. Sec. Fund	5150021230	ATHLETIC DIR SECY IMRF	0.00	0.00	0.00	0.00	0.00	0.00	0.00
I.M.R.F./Soc. Sec. Fund		ATHLETIC DIR SECY IMRF	5,149.44	414.48	0.00	0.00	1,331.28	3,818.16	74.15
I.M.R.F./Soc. Sec. Fund		ATHLETIC IMRF	2,321.28	258.04	0.00	0.00	-196.33	2,517.61	108.46
I.M.R.F./Soc. Sec. Fund		50 E 1500 2120 30 300	0.00	54.40	0.00	0.00	-275.87	275.87	128 0.00
I.M.R.F./Soc. Sec. Fund		TECH DIR IMRF	526.56	42.38	0.00	0.00	75.39	451.17	85.68
I.M.R.F./Soc. Sec. Fund		50 E 1500 2120 30 300	0.00	0.00	0.00	0.00	-437.97	437.97	0.00
I.M.R.F./Soc. Sec. Fund		ATH/ACT	0.00	37.90	0.00	0.00	-192.19	192.19	0.00
I.M.R.F./Soc. Sec. Fund	51500212	MAIN OFFICE IMRF	0.00	0.00	0.00	0.00	0.00	0.00	0.00
I.M.R.F./Soc. Sec. Fund	5150021270	ACTIVITY DIR SECY IMRF	4,815.12	387.58	0.00	0.00	1,244.74	3,570.38	74.15
I.M.R.F./Soc. Sec. Fund		ATH/ACT	0.00	0.00	0.00	0.00	0.00	0.00	0.00
I.M.R.F./Soc. Sec. Fund		ATH/ACT	468.00	54.03	0.00	0.00	-22.47	490.47	104.80
I.M.R.F./Soc. Sec. Fund		ATH/ACT	174.00	14.00	0.00	0.00	45.00	129.00	74.14
I.M.R.F./Soc. Sec. Fund		ATH/ACT	0.00	0.00	0.00	0.00	-178.20	178.20	0.00
I.M.R.F./Soc. Sec. Fund		ATH/ACT	290.64	23.40	0.00	0.00	99.34	191.30	65.82
I.M.R.F./Soc. Sec. Fund		ATH/ACT	0.00	0.00	0.00	0.00	-217.43	217.43	0.00
I.M.R.F./Soc. Sec. Fund	50-1500-213	INVITATIONAL WKRS (FR)	0.00	0.00	0.00	0.00	0.00	0.00	0.00
I.M.R.F./Soc. Sec. Fund	5150021330	GOLF COACH FICA	0.00	0.00	0.00	0.00	0.00	0.00	0.00

Expenditure Report

Fiscal Year: 2021-2022
Month: March

COUNTY OF GRUNDY SCHOOL DIST 111

Fund Description	Account	Account Description	Revised Budget	MTD Activity	Encumbrance	Pending Activity	Available Funds	Year to Date Activity	Percent of Budget Used
I.M.R.F./Soc. Sec. Fund		ATH/ACT	2,834.16	236.12	0.00	0.00	708.72	2,125.44	74.99
I.M.R.F./Soc. Sec. Fund		ATH/ACT	1,403.76	161.61	0.00	0.00	-413.94	1,817.70	129.49
I.M.R.F./Soc. Sec. Fund		ATH/ACT	0.00	0.00	0.00	0.00	0.00	0.00	0.00
I.M.R.F./Soc. Sec. Fund		ATH/ACT	0.00	0.00	0.00	0.00	0.00	0.00	0.00
I.M.R.F./Soc. Sec. Fund		ATH/ACT	11,652.96	0.00	0.00	0.00	10,681.88	971.08	8.33
I.M.R.F./Soc. Sec. Fund		ATH/ACT	3,234.24	0.00	0.00	0.00	2,959.95	274.29	8.48
I.M.R.F./Soc. Sec. Fund		ATH/ACT	0.00	34.08	0.00	0.00	-170.40	170.40	0.00
I.M.R.F./Soc. Sec. Fund		ATH/ACT	0.00	132.10	0.00	0.00	-1,183.03	1,183.03	0.00
I.M.R.F./Soc. Sec. Fund		ATH/ACT	318.72	26.54	0.00	0.00	43.10	275.62	86.48
I.M.R.F./Soc. Sec. Fund		ATH/ACT	7,195.92	0.00	0.00	0.00	5,727.08	1,468.84	20.41
I.M.R.F./Soc. Sec. Fund		ATH/ACT	0.00	0.00	0.00	0.00	-323.70	323.70	129 0.00
I.M.R.F./Soc. Sec. Fund		ATH/ACT	0.00	0.00	0.00	0.00	-246.02	246.02	0.00
I.M.R.F./Soc. Sec. Fund		ATH/ACT	0.00	0.00	0.00	0.00	-294.26	294.26	0.00
I.M.R.F./Soc. Sec. Fund		ATH/ACT	0.00	0.00	0.00	0.00	0.00	0.00	0.00
I.M.R.F./Soc. Sec. Fund		ATH/ACT	0.00	23.74	0.00	0.00	-147.69	147.69	0.00
I.M.R.F./Soc. Sec. Fund	51500213	MAIN OFFICE FICA	0.00	0.00	0.00	0.00	0.00	0.00	0.00
I.M.R.F./Soc. Sec. Fund	5150021370	ACTIVITIES FICA	2,696.16	224.54	0.00	0.00	674.46	2,021.70	74.98
I.M.R.F./Soc. Sec. Fund		ATH/ACT	0.00	0.00	0.00	0.00	0.00	0.00	0.00
I.M.R.F./Soc. Sec. Fund		ATH/ACT	283.20	33.85	0.00	0.00	-19.60	302.80	106.92
I.M.R.F./Soc. Sec. Fund		ATH/ACT	105.36	8.78	0.00	0.00	26.34	79.02	75.00
I.M.R.F./Soc. Sec. Fund		ATH/ACT	0.00	0.00	0.00	0.00	0.00	0.00	0.00
I.M.R.F./Soc. Sec. Fund		ATH/ACT	0.00	0.00	0.00	0.00	-386.88	386.88	0.00
I.M.R.F./Soc. Sec. Fund		ATH/ACT	0.00	0.00	0.00	0.00	-105.28	105.28	0.00
I.M.R.F./Soc. Sec. Fund		ATH/ACT	0.00	0.00	0.00	0.00	-105.28	105.28	0.00

Expenditure Report

Fiscal Year: 2021-2022
Month: March

COUNTY OF GRUNDY SCHOOL DIST 111

Fund Description	Account	Account Description	Revised Budget	MTD Activity	Encumbrance	Pending Activity	Available Funds	Year to Date Activity	Percent of Budget Used
I.M.R.F./Soc. Sec. Fund		ATH/ACT	0.00	0.00	0.00	0.00	-108.59	108.59	0.00
I.M.R.F./Soc. Sec. Fund		ATH/ACT	175.92	14.66	0.00	0.00	58.64	117.28	66.67
I.M.R.F./Soc. Sec. Fund		ATH/ACT	0.00	0.00	0.00	0.00	-338.15	338.15	0.00
I.M.R.F./Soc. Sec. Fund		ATH/ACT	0.00	0.00	0.00	0.00	0.00	0.00	0.00
I.M.R.F./Soc. Sec. Fund		ATH/ACT	0.00	0.00	0.00	0.00	-177.32	177.32	0.00
I.M.R.F./Soc. Sec. Fund	50-1500-214	INVITATIONAL WKRS (MR)	0.00	0.00	0.00	0.00	0.00	0.00	0.00
I.M.R.F./Soc. Sec. Fund	5150021530	ASST ATHLETIC DIR	0.00	0.00	0.00	0.00	0.00	0.00	0.00
I.M.R.F./Soc. Sec. Fund	50-1500-	ASST ATHLETIC DIR	0.00	0.00	0.00	0.00	0.00	0.00	0.00
I.M.R.F./Soc. Sec. Fund	5150021430	ATHLETIC MEDICARE	2,003.04	194.76	0.00	0.00	408.06	1,594.98	79.63
I.M.R.F./Soc. Sec. Fund		ATH/ACT	870.24	72.48	0.00	0.00	218.63	651.61	74.88
I.M.R.F./Soc. Sec. Fund		ATH/ACT	896.88	72.52	0.00	0.00	-116.08	1,012.96	13012.94
I.M.R.F./Soc. Sec. Fund		ATH/ACT	177.84	14.81	0.00	0.00	45.07	132.77	74.66
I.M.R.F./Soc. Sec. Fund		ATH/ACT	232.08	19.34	0.00	0.00	58.87	173.21	74.63
I.M.R.F./Soc. Sec. Fund		ATH/ACT	136.80	11.38	0.00	0.00	34.95	101.85	74.45
I.M.R.F./Soc. Sec. Fund		ATH/ACT	404.16	37.04	0.00	0.00	77.45	326.71	80.84
I.M.R.F./Soc. Sec. Fund		ATH/ACT	304.32	25.36	0.00	0.00	83.06	221.26	72.71
I.M.R.F./Soc. Sec. Fund		ATH/ACT	2,191.20	24.32	0.00	0.00	1,811.26	379.94	17.34
I.M.R.F./Soc. Sec. Fund		ATH/ACT	389.04	32.40	0.00	0.00	98.09	290.95	74.79
I.M.R.F./Soc. Sec. Fund		ATH/ACT	3,491.76	63.90	0.00	0.00	2,653.46	838.30	24.01
I.M.R.F./Soc. Sec. Fund		ATH/ACT	1,223.76	47.72	0.00	0.00	738.42	485.34	39.66
I.M.R.F./Soc. Sec. Fund		ATH/ACT	266.88	30.18	0.00	0.00	-60.87	327.75	122.81
I.M.R.F./Soc. Sec. Fund		ATH/ACT	278.64	54.12	0.00	0.00	-207.04	485.68	174.30
I.M.R.F./Soc. Sec. Fund		ATH/ACT	136.56	19.36	0.00	0.00	22.77	113.79	83.33
I.M.R.F./Soc. Sec. Fund		ATH/ACT	325.44	27.12	0.00	0.00	73.59	251.85	77.39

Expenditure Report

Fiscal Year: 2021-2022
Month: March

COUNTY OF GRUNDY SCHOOL DIST 111

Fund Description	Account	Account Description	Revised Budget	MTD Activity	Encumbrance	Pending Activity	Available Funds	Year to Date Activity	Percent of Budget Used
I.M.R.F./Soc. Sec. Fund		ATH/ACT	1,682.88	0.00	0.00	0.00	1,339.36	343.52	20.41
I.M.R.F./Soc. Sec. Fund		ATH/ACT	310.56	28.49	0.00	0.00	64.64	245.92	79.19
I.M.R.F./Soc. Sec. Fund		ATH/ACT	438.96	36.57	0.00	0.00	43.86	395.10	90.01
I.M.R.F./Soc. Sec. Fund		ATH/ACT	100.80	8.40	0.00	0.00	-32.37	133.17	132.11
I.M.R.F./Soc. Sec. Fund		ATH/ACT	127.68	10.64	0.00	0.00	32.57	95.11	74.49
I.M.R.F./Soc. Sec. Fund		ATH/ACT	348.48	35.29	0.00	0.00	31.09	317.39	91.08
I.M.R.F./Soc. Sec. Fund		ATH/ACT	246.00	31.98	0.00	0.00	-31.57	277.57	112.83
I.M.R.F./Soc. Sec. Fund		ATH/ACT	0.00	0.00	0.00	0.00	0.00	0.00	0.00
I.M.R.F./Soc. Sec. Fund		ATH/ACT	0.00	5.56	0.00	0.00	-34.58	34.58	0.00
I.M.R.F./Soc. Sec. Fund	5150021470	ACTIVITIES MEDICARE	1,378.56	114.88	0.00	0.00	349.23	1,029.33	74.67
I.M.R.F./Soc. Sec. Fund		ATH/ACT	630.72	54.20	0.00	0.00	108.85	521.87	13182.74
I.M.R.F./Soc. Sec. Fund		ATH/ACT	321.36	26.81	0.00	0.00	81.75	239.61	74.56
I.M.R.F./Soc. Sec. Fund		ATH/ACT	162.48	23.28	0.00	0.00	-85.37	247.85	152.54
I.M.R.F./Soc. Sec. Fund		ATH/ACT	70.80	5.88	0.00	0.00	18.06	52.74	74.49
I.M.R.F./Soc. Sec. Fund		ATH/ACT	174.96	14.60	0.00	0.00	44.54	130.42	74.54
I.M.R.F./Soc. Sec. Fund		ATH/ACT	70.08	5.84	0.00	0.00	17.56	52.52	74.94
I.M.R.F./Soc. Sec. Fund		ATH/ACT	33.84	2.82	0.00	0.00	8.70	25.14	74.29
I.M.R.F./Soc. Sec. Fund		ATH/ACT	291.12	24.26	0.00	0.00	72.81	218.31	74.99
I.M.R.F./Soc. Sec. Fund		ATH/ACT	143.28	11.94	0.00	0.00	36.75	106.53	74.35
I.M.R.F./Soc. Sec. Fund		ATH/ACT	184.08	15.34	0.00	0.00	46.92	137.16	74.51
I.M.R.F./Soc. Sec. Fund		ATH/ACT	78.00	6.51	0.00	0.00	19.97	58.03	74.40
I.M.R.F./Soc. Sec. Fund		ATH/ACT	116.64	9.72	0.00	0.00	29.69	86.95	74.55
I.M.R.F./Soc. Sec. Fund		ATH/ACT	193.92	16.14	0.00	0.00	51.65	142.27	73.37
I.M.R.F./Soc. Sec. Fund		ATH/ACT	30.24	2.54	0.00	0.00	7.40	22.84	75.53

Expenditure Report

Fiscal Year: 2021-2022
Month: March

COUNTY OF GRUNDY SCHOOL DIST 111

Fund Description	Account	Account Description	Revised Budget	MTD Activity	Encumbrance	Pending Activity	Available Funds	Year to Date Activity	Percent of Budget Used
I.M.R.F./Soc. Sec. Fund		ATH/ACT	45.60	3.80	0.00	0.00	11.42	34.18	74.96
I.M.R.F./Soc. Sec. Fund		ATH/ACT	33.60	2.80	0.00	0.00	8.40	25.20	75.00
I.M.R.F./Soc. Sec. Fund		ATH/ACT	105.60	8.78	0.00	0.00	26.49	79.11	74.91
I.M.R.F./Soc. Sec. Fund		ATH/ACT	30.48	2.54	0.00	0.00	7.62	22.86	75.00
I.M.R.F./Soc. Sec. Fund		ATH/ACT	48.96	4.08	0.00	0.00	6.08	42.88	87.58
I.M.R.F./Soc. Sec. Fund		ATH/ACT	31.92	2.66	0.00	0.00	8.28	23.64	74.06
I.M.R.F./Soc. Sec. Fund		ATH/ACT	162.00	13.50	0.00	0.00	41.38	120.62	74.46
I.M.R.F./Soc. Sec. Fund		ATH/ACT	77.52	6.46	0.00	0.00	19.68	57.84	74.61
I.M.R.F./Soc. Sec. Fund		ATH/ACT	0.00	2.55	0.00	0.00	-109.18	109.18	0.00
I.M.R.F./Soc. Sec. Fund		ATH/ACT	0.00	0.00	0.00	0.00	-3.09	3.09	0.00
I.M.R.F./Soc. Sec. Fund		ATH/ACT	42.48	3.54	0.00	0.00	10.98	31.50	13274.15
I.M.R.F./Soc. Sec. Fund		ATH/ACT	41.76	3.49	0.00	0.00	10.72	31.04	74.33
I.M.R.F./Soc. Sec. Fund		ATH/ACT	87.36	7.26	0.00	0.00	22.16	65.20	74.63
I.M.R.F./Soc. Sec. Fund		ATH/ACT	41.76	3.48	0.00	0.00	10.74	31.02	74.28
I.M.R.F./Soc. Sec. Fund		ATH/ACT	0.00	0.00	0.00	0.00	-3.81	3.81	0.00
I.M.R.F./Soc. Sec. Fund		ATH/ACT	57.84	4.80	0.00	0.00	14.87	42.97	74.29
I.M.R.F./Soc. Sec. Fund		ATH/ACT	39.60	3.30	0.00	0.00	9.88	29.72	75.05
I.M.R.F./Soc. Sec. Fund		ATH/ACT	0.00	0.00	0.00	0.00	-24.62	24.62	0.00
I.M.R.F./Soc. Sec. Fund		ATH/ACT	24.72	2.06	0.00	0.00	6.18	18.54	75.00
I.M.R.F./Soc. Sec. Fund		ATH/ACT	0.00	0.00	0.00	0.00	-24.62	24.62	0.00
I.M.R.F./Soc. Sec. Fund		ATH/ACT	29.52	2.46	0.00	0.00	7.38	22.14	75.00
I.M.R.F./Soc. Sec. Fund		ATH/ACT	66.24	5.52	0.00	0.00	19.66	46.58	70.32
I.M.R.F./Soc. Sec. Fund		ATH/ACT	75.60	6.32	0.00	0.00	-6.52	82.12	108.62
I.M.R.F./Soc. Sec. Fund		ATH/ACT	29.52	2.46	0.00	0.00	7.39	22.13	74.97

Expenditure Report

Fiscal Year: 2021-2022
Month: March

COUNTY OF GRUNDY SCHOOL DIST 111

Fund Description	Account	Account Description	Revised Budget	MTD Activity	Encumbrance	Pending Activity	Available Funds	Year to Date Activity	Percent of Budget Used
I.M.R.F./Soc. Sec. Fund		ATH/ACT	0.00	0.00	0.00	0.00	0.00	0.00	0.00
I.M.R.F./Soc. Sec. Fund		ATH/ACT	71.52	5.96	0.00	0.00	21.30	50.22	70.22
I.M.R.F./Soc. Sec. Fund		ATH/ACT	33.36	2.78	0.00	0.00	8.34	25.02	75.00
I.M.R.F./Soc. Sec. Fund		ATH/ACT	0.00	0.00	0.00	0.00	-421.39	421.39	0.00
I.M.R.F./Soc. Sec. Fund		ATH/ACT	0.00	0.00	0.00	0.00	0.00	0.00	0.00
I.M.R.F./Soc. Sec. Fund		ATH/ACT	36.48	3.03	0.00	0.00	9.13	27.35	74.97
I.M.R.F./Soc. Sec. Fund		ATH/ACT	0.00	0.00	0.00	0.00	-41.47	41.47	0.00
I.M.R.F./Soc. Sec. Fund		50 E 1500 2140 70 300	0.00	2.72	0.00	0.00	-9.52	9.52	0.00
I.M.R.F./Soc. Sec. Fund	50-1600-	SUMMER SCHOOL SALARY	0.00	0.00	0.00	0.00	0.00	0.00	0.00
I.M.R.F./Soc. Sec. Fund	50-1600-	SUMMER SCHOOL SALARY	0.00	0.00	0.00	0.00	0.00	0.00	0.00
I.M.R.F./Soc. Sec. Fund	51600214	SUMMER SCHOOL	0.00	0.00	0.00	0.00	0.00	0.00	133 0.00
I.M.R.F./Soc. Sec. Fund	50-1700-	SUMMER DR ED SALARY	0.00	0.00	0.00	0.00	0.00	0.00	0.00
I.M.R.F./Soc. Sec. Fund	50-1700-	SUMMER DR ED SALARY	0.00	0.00	0.00	0.00	0.00	0.00	0.00
I.M.R.F./Soc. Sec. Fund	5170021430	SUMMER DR ED	0.00	0.00	0.00	0.00	0.00	0.00	0.00
I.M.R.F./Soc. Sec. Fund	5170021421	DRIVER ED MEDICARE	5,918.88	488.08	0.00	0.00	1,523.51	4,395.37	74.26
I.M.R.F./Soc. Sec. Fund	51900212	PROJ IND SECY IMRF	0.00	0.00	0.00	0.00	0.00	0.00	0.00
I.M.R.F./Soc. Sec. Fund		PROJ IND SECY IMRF	3,395.52	229.45	0.00	0.00	928.81	2,466.71	72.65
I.M.R.F./Soc. Sec. Fund	51900213	PROJ IND SECY FICA	0.00	0.00	0.00	0.00	0.00	0.00	0.00
I.M.R.F./Soc. Sec. Fund		PROJ IND SECY FICA	1,822.80	124.45	0.00	0.00	487.42	1,335.38	73.26
I.M.R.F./Soc. Sec. Fund	51900214	PROJ IND SECY MEDICARE	1,422.24	118.50	0.00	0.00	356.69	1,065.55	74.92
I.M.R.F./Soc. Sec. Fund		PROJ IND SECY MEDICARE	426.24	29.10	0.00	0.00	113.96	312.28	73.26
I.M.R.F./Soc. Sec. Fund	50-2100-	MAIN OFFICE SECY	0.00	0.00	0.00	0.00	0.00	0.00	0.00
I.M.R.F./Soc. Sec. Fund		MAIN OFFICE SECY	3,837.84	279.61	0.00	0.00	1,235.34	2,602.50	67.81
I.M.R.F./Soc. Sec. Fund	521002121	PROJ IND DIR SECY IMRF	0.00	0.00	0.00	0.00	0.00	0.00	0.00

Expenditure Report

Fiscal Year: 2021-2022
Month: March

COUNTY OF GRUNDY SCHOOL DIST 111

Fund Description	Account	Account Description	Revised Budget	MTD Activity	Encumbrance	Pending Activity	Available Funds	Year to Date Activity	Percent of Budget Used
I.M.R.F./Soc. Sec. Fund	50-2100-	DIR OF STUDENT SERV	0.00	0.00	0.00	0.00	0.00	0.00	0.00
I.M.R.F./Soc. Sec. Fund	50-2100-	MAIN OFFICE SECY	0.00	0.00	0.00	0.00	0.00	0.00	0.00
I.M.R.F./Soc. Sec. Fund		MAIN OFFICE SECY	2,321.52	166.43	0.00	0.00	755.06	1,566.46	67.48
I.M.R.F./Soc. Sec. Fund	521002131	PROJ IND DIR SECY FICA	0.00	0.00	0.00	0.00	0.00	0.00	0.00
I.M.R.F./Soc. Sec. Fund	50-2100-	DIR OF STUDENT SERV	0.00	0.00	0.00	0.00	0.00	0.00	0.00
I.M.R.F./Soc. Sec. Fund	52100214	ASST PRIN-LEARN MED	0.00	0.00	0.00	0.00	0.00	0.00	0.00
I.M.R.F./Soc. Sec. Fund		MAIN OFFICE SECY	542.88	38.93	0.00	0.00	176.55	366.33	67.48
I.M.R.F./Soc. Sec. Fund	50-2100-	DIR STUDENT SERV. SA	1,876.56	156.38	0.00	0.00	467.48	1,409.08	75.09
I.M.R.F./Soc. Sec. Fund	52100215	DIR OF STUD SER	0.00	0.00	0.00	0.00	0.00	0.00	0.00
I.M.R.F./Soc. Sec. Fund	50-2110-212	TITLE 1 SALARIES IMRF	2,227.92	0.00	0.00	0.00	761.72	1,466.20	65.81
I.M.R.F./Soc. Sec. Fund	50-2110-213	TITLE 1 SALARIES FICA	1,347.60	0.00	0.00	0.00	453.07	894.53	13466.38
I.M.R.F./Soc. Sec. Fund	50-2110-214	TITLE 1 SALARIES	593.28	23.16	0.00	0.00	176.02	417.26	70.33
I.M.R.F./Soc. Sec. Fund	52113214	SOCIAL WORKER	3,761.52	271.85	0.00	0.00	1,365.70	2,395.82	63.69
I.M.R.F./Soc. Sec. Fund			0.00	0.00	0.00	0.00	0.00	0.00	0.00
I.M.R.F./Soc. Sec. Fund			0.00	0.00	0.00	0.00	0.00	0.00	0.00
I.M.R.F./Soc. Sec. Fund			0.00	0.00	0.00	0.00	0.00	0.00	0.00
I.M.R.F./Soc. Sec. Fund	50-2120-	GUIDANCE SALARY (RM)	0.00	0.00	0.00	0.00	0.00	0.00	0.00
I.M.R.F./Soc. Sec. Fund	50-2120-	GUIDANCE SALARY (FR)	0.00	0.00	0.00	0.00	0.00	0.00	0.00
I.M.R.F./Soc. Sec. Fund	52120214	GUIDANCE MEDICARE	8,103.60	600.04	0.00	0.00	2,634.92	5,468.68	67.48
I.M.R.F./Soc. Sec. Fund		50 E 2120 2140 00 300	0.00	78.72	0.00	0.00	-401.40	401.40	0.00
I.M.R.F./Soc. Sec. Fund	521252120	REGISTRAR IMRF	5,280.00	363.00	0.00	0.00	1,626.41	3,653.59	69.20
I.M.R.F./Soc. Sec. Fund	521252121	STDNT CENTER IMRF	4,841.04	355.52	0.00	0.00	1,476.19	3,364.85	69.51
I.M.R.F./Soc. Sec. Fund	521252122	ASST REGISTRAR IMRF	3,573.12	267.06	0.00	0.00	994.70	2,578.42	72.16
I.M.R.F./Soc. Sec. Fund	52125213	REGISTRAR FICA	2,865.60	199.84	0.00	0.00	868.08	1,997.52	69.71

Expenditure Report

Fiscal Year: 2021-2022
Month: March

COUNTY OF GRUNDY SCHOOL DIST 111

Fund Description	Account	Account Description	Revised Budget	MTD Activity	Encumbrance	Pending Activity	Available Funds	Year to Date Activity	Percent of Budget Used
I.M.R.F./Soc. Sec. Fund	521252131	STDNT CENTER FICA	2,900.88	222.66	0.00	0.00	791.95	2,108.93	72.70
I.M.R.F./Soc. Sec. Fund	521252132	ASST REGISTRAR FICA	2,161.44	167.24	0.00	0.00	584.73	1,576.71	72.95
I.M.R.F./Soc. Sec. Fund	52125214	CAREER CENTER	670.08	46.74	0.00	0.00	202.93	467.15	69.72
I.M.R.F./Soc. Sec. Fund		ACAD RESOURCE CTR	678.24	52.06	0.00	0.00	185.12	493.12	72.71
I.M.R.F./Soc. Sec. Fund		ASST REGISTRAR	505.44	39.12	0.00	0.00	136.65	368.79	72.96
I.M.R.F./Soc. Sec. Fund			0.00	0.00	0.00	0.00	0.00	0.00	0.00
I.M.R.F./Soc. Sec. Fund			0.00	0.00	0.00	0.00	0.00	0.00	0.00
I.M.R.F./Soc. Sec. Fund			0.00	0.00	0.00	0.00	0.00	0.00	0.00
I.M.R.F./Soc. Sec. Fund	52134212	NURSE IMRF	5,166.48	490.56	0.00	0.00	1,494.39	3,672.09	71.08
I.M.R.F./Soc. Sec. Fund	521342122	NURSE IMRF S.C.	3,642.48	517.52	0.00	0.00	352.29	3,290.19	90.33
I.M.R.F./Soc. Sec. Fund	52134213	NURSE FICA	4,206.48	307.22	0.00	0.00	1,908.03	2,298.45	13554.64
I.M.R.F./Soc. Sec. Fund	521342132	NURSE FICA S.C.	2,203.44	324.10	0.00	0.00	181.47	2,021.97	91.76
I.M.R.F./Soc. Sec. Fund	50-2134-	NURSE SALARY (MR)	983.52	71.84	0.00	0.00	446.10	537.42	54.64
I.M.R.F./Soc. Sec. Fund	50-2134-	NURSE SALARY S.C. (MR)	515.28	75.80	0.00	0.00	42.42	472.86	91.77
I.M.R.F./Soc. Sec. Fund			0.00	0.00	0.00	0.00	0.00	0.00	0.00
I.M.R.F./Soc. Sec. Fund			0.00	0.00	0.00	0.00	0.00	0.00	0.00
I.M.R.F./Soc. Sec. Fund			0.00	0.00	0.00	0.00	0.00	0.00	0.00
I.M.R.F./Soc. Sec. Fund	50-2140-214	PSYCHOLOGIST SALARY	2,807.04	178.76	0.00	0.00	1,139.20	1,667.84	59.42
I.M.R.F./Soc. Sec. Fund	50-2190-	CSBO SALARY IMRF	0.00	500.64	0.00	0.00	-2,485.28	2,485.28	0.00
I.M.R.F./Soc. Sec. Fund	50-2190-	CSBO SALARY FICA	3,593.04	298.62	0.00	0.00	1,556.38	2,036.66	56.68
I.M.R.F./Soc. Sec. Fund	52190214	BUSINESS MGR MEDICARE	840.48	69.84	0.00	0.00	199.70	640.78	76.24
I.M.R.F./Soc. Sec. Fund	50-2210-	PROF. DEVELOPMENT	0.00	0.00	0.00	0.00	0.00	0.00	0.00
I.M.R.F./Soc. Sec. Fund	50-2210-	DIR C/I SEC. SALARY IMRF	3,683.28	276.86	0.00	0.00	986.08	2,697.20	73.23
I.M.R.F./Soc. Sec. Fund	50-2210-	PROF. DEVELOPMENT	0.00	0.00	0.00	0.00	0.00	0.00	0.00

Expenditure Report

Fiscal Year: 2021-2022
Month: March

COUNTY OF GRUNDY SCHOOL DIST 111

Fund Description	Account	Account Description	Revised Budget	MTD Activity	Encumbrance	Pending Activity	Available Funds	Year to Date Activity	Percent of Budget Used
I.M.R.F./Soc. Sec. Fund	50-2210-	DIR C/I SEC. SALARY (FR)	2,085.84	161.40	0.00	0.00	533.21	1,552.63	74.44
I.M.R.F./Soc. Sec. Fund		TITLE II MEDICARE	0.00	0.00	0.00	0.00	-16.58	16.58	0.00
I.M.R.F./Soc. Sec. Fund	50-2210-	DIRECTOR C/I SALARY	1,692.00	140.84	0.00	0.00	259.01	1,432.99	84.69
I.M.R.F./Soc. Sec. Fund		DIRECTOR C/I SEC	487.92	37.76	0.00	0.00	124.75	363.17	74.43
I.M.R.F./Soc. Sec. Fund	52212214	CURR DEVELOP/LEARN OBJ	0.00	0.00	0.00	0.00	0.00	0.00	0.00
I.M.R.F./Soc. Sec. Fund	52213212	STAFF DEVELOPMENT	0.00	0.00	0.00	0.00	0.00	0.00	0.00
I.M.R.F./Soc. Sec. Fund	52213213	STAFF DEVELOPMENT	0.00	0.00	0.00	0.00	0.00	0.00	0.00
I.M.R.F./Soc. Sec. Fund	52213214	TYPE 75 MEDICARE	0.00	0.00	0.00	0.00	0.00	0.00	0.00
I.M.R.F./Soc. Sec. Fund	52222212	LIBRARY IMRF	5,334.96	406.44	0.00	0.00	1,506.52	3,828.44	71.76
I.M.R.F./Soc. Sec. Fund	522222122	LIBRARY IMRF S.C.	2,739.84	220.52	0.00	0.00	719.85	2,019.99	73.73
I.M.R.F./Soc. Sec. Fund	52222213	LIBRARY FICA	3,227.04	254.54	0.00	0.00	885.19	2,341.85	13672.57
I.M.R.F./Soc. Sec. Fund	522222132	LIB ASST FICA S.C.	1,525.68	126.94	0.00	0.00	388.98	1,136.70	74.50
I.M.R.F./Soc. Sec. Fund	52222214	LIBRARY MEDICARE	754.56	59.52	0.00	0.00	206.93	547.63	72.58
I.M.R.F./Soc. Sec. Fund		LIB ASST FICA	723.84	60.32	0.00	0.00	151.20	572.64	79.11
I.M.R.F./Soc. Sec. Fund	522222142	LIB ASST MEDICARE S.C.	356.88	29.68	0.00	0.00	91.05	265.83	74.49
I.M.R.F./Soc. Sec. Fund	52225212	TECH IMRF	9,433.20	759.26	0.00	0.00	2,438.82	6,994.38	74.15
I.M.R.F./Soc. Sec. Fund		LIB ASST IMRF	7,216.56	580.84	0.00	0.00	1,811.13	5,405.43	74.90
I.M.R.F./Soc. Sec. Fund	522252122	TECH IMRF S.C.	6,575.04	529.24	0.00	0.00	1,898.74	4,676.30	71.12
I.M.R.F./Soc. Sec. Fund	52225213	TECH FICA	5,452.08	454.22	0.00	0.00	735.20	4,716.88	86.52
I.M.R.F./Soc. Sec. Fund		LIB ASST FICA	4,223.04	348.68	0.00	0.00	1,032.43	3,190.61	75.55
I.M.R.F./Soc. Sec. Fund	522252132	TECH ASST FICA S.C.	3,959.52	291.58	0.00	0.00	1,225.37	2,734.15	69.05
I.M.R.F./Soc. Sec. Fund	52225214	TECH/CYBRARY AIDE	1,275.12	106.22	0.00	0.00	171.94	1,103.18	86.52
I.M.R.F./Soc. Sec. Fund		TECH ASST MEDICARE	987.60	81.54	0.00	0.00	241.44	746.16	75.55
I.M.R.F./Soc. Sec. Fund	50-2225-	TECH ASST SALARY S.C.	926.16	68.20	0.00	0.00	286.65	639.51	69.05

Expenditure Report

Fiscal Year: 2021-2022
Month: March

COUNTY OF GRUNDY SCHOOL DIST 111

Fund Description	Account	Account Description	Revised Budget	MTD Activity	Encumbrance	Pending Activity	Available Funds	Year to Date Activity	Percent of Budget Used
I.M.R.F./Soc. Sec. Fund	50-2300-212	TEST PROCTOR IMRF	0.00	0.00	0.00	0.00	0.00	0.00	0.00
I.M.R.F./Soc. Sec. Fund	50-2300-213	TEST PROCTOR FICA	0.00	0.00	0.00	0.00	0.00	0.00	0.00
I.M.R.F./Soc. Sec. Fund	50-2300-214	TEST PROCTOR	0.00	0.00	0.00	0.00	0.00	0.00	0.00
I.M.R.F./Soc. Sec. Fund	52310213	BOARD OF ED FICA	0.00	0.00	0.00	0.00	0.00	0.00	0.00
I.M.R.F./Soc. Sec. Fund	52310214	BOARD OF ED MEDICARE	0.00	0.00	0.00	0.00	0.00	0.00	0.00
I.M.R.F./Soc. Sec. Fund	52312212	BOARD SECY IMRF	0.00	0.00	0.00	0.00	0.00	0.00	0.00
I.M.R.F./Soc. Sec. Fund	52312213	BOARD SECY FICA	0.00	0.00	0.00	0.00	0.00	0.00	0.00
I.M.R.F./Soc. Sec. Fund	52313214	PERFORMANCE	0.00	0.00	0.00	0.00	0.00	0.00	0.00
I.M.R.F./Soc. Sec. Fund	52321212	SUPT SECY IMRF	5,305.92	558.73	0.00	0.00	1,354.99	3,950.93	74.46
I.M.R.F./Soc. Sec. Fund	52321213	SUPT SECY FICA	2,769.84	306.94	0.00	0.00	641.64	2,128.20	76.83
I.M.R.F./Soc. Sec. Fund	52321214	SUPT SECY MEDICARE	647.76	71.79	0.00	0.00	150.04	497.72	1376.84
I.M.R.F./Soc. Sec. Fund		SUPT MEDICARE	2,921.04	243.42	0.00	0.00	780.58	2,140.46	73.28
I.M.R.F./Soc. Sec. Fund	52367212	CAMPUS MONITOR IMRF	20,505.36	0.00	0.00	0.00	15,078.96	5,426.40	26.46
I.M.R.F./Soc. Sec. Fund		NURSE IMRF	463.68	0.00	0.00	0.00	382.76	80.92	17.45
I.M.R.F./Soc. Sec. Fund		DEANS SECY IMRF	1,269.60	0.00	0.00	0.00	958.60	311.00	24.50
I.M.R.F./Soc. Sec. Fund	52367213	CAMPUS MONITOR FICA	10,922.88	0.00	0.00	0.00	8,005.24	2,917.64	26.71
I.M.R.F./Soc. Sec. Fund		NURSE FICE	280.32	0.00	0.00	0.00	231.40	48.92	17.45
I.M.R.F./Soc. Sec. Fund		DEANS SECY FICA	651.12	0.00	0.00	0.00	496.97	154.15	23.67
I.M.R.F./Soc. Sec. Fund	52367214	CAMPUS MONITOR	2,554.32	0.00	0.00	0.00	1,871.97	682.35	26.71
I.M.R.F./Soc. Sec. Fund		NURSE MEDICARE	65.76	0.00	0.00	0.00	54.30	11.46	17.43
I.M.R.F./Soc. Sec. Fund		DEANS SECY MEDICARE	743.28	0.00	0.00	0.00	568.64	174.64	23.50
I.M.R.F./Soc. Sec. Fund	52410212	PRINCIPAL SECY IMRF	4,161.36	344.45	0.00	0.00	1,066.35	3,095.01	74.37
I.M.R.F./Soc. Sec. Fund		AP SECY IMRF	5,666.40	456.08	0.00	0.00	1,464.96	4,201.44	74.15
I.M.R.F./Soc. Sec. Fund	52140213	PRINCIPAL SECY FICA	2,406.00	206.40	0.00	0.00	595.60	1,810.40	75.25

Expenditure Report

Fiscal Year: 2021-2022
Month: March

COUNTY OF GRUNDY SCHOOL DIST 111

Fund Description	Account	Account Description	Revised Budget	MTD Activity	Encumbrance	Pending Activity	Available Funds	Year to Date Activity	Percent of Budget Used
I.M.R.F./Soc. Sec. Fund		AP SECY FICA	3,280.80	273.34	0.00	0.00	820.38	2,460.42	74.99
I.M.R.F./Soc. Sec. Fund	52410214	PRINCIPAL SECY	562.56	48.27	0.00	0.00	139.15	423.41	75.26
I.M.R.F./Soc. Sec. Fund		PRINCIPAL MEDICARE	1,992.48	166.04	0.00	0.00	496.51	1,495.97	75.08
I.M.R.F./Soc. Sec. Fund		AP SECY MEDICARE	767.28	63.92	0.00	0.00	191.88	575.40	74.99
I.M.R.F./Soc. Sec. Fund		ASST PRINCIPAL	1,695.60	141.30	0.00	0.00	417.94	1,277.66	75.35
I.M.R.F./Soc. Sec. Fund		DEANS MEDICARE	4,140.48	343.93	0.00	0.00	1,096.33	3,044.15	73.52
I.M.R.F./Soc. Sec. Fund	524102142	PRINCIPAL MEDICARE S.C.	1,522.56	126.88	0.00	0.00	380.21	1,142.35	75.03
I.M.R.F./Soc. Sec. Fund	52490212	DEANS SECY IMRF	6,355.68	489.70	0.00	0.00	1,627.07	4,728.61	74.40
I.M.R.F./Soc. Sec. Fund	52490213	DEANS SECY FICA	3,320.40	262.86	0.00	0.00	833.82	2,486.58	74.89
I.M.R.F./Soc. Sec. Fund	52490214	DEANS OFFICE MEDICARE	776.40	61.46	0.00	0.00	194.97	581.43	74.89
I.M.R.F./Soc. Sec. Fund	50-2510-	CSBO SALARY IMRF	0.00	1,001.42	0.00	0.00	-4,971.32	4,971.32	138 0.00
I.M.R.F./Soc. Sec. Fund	50-2510-	CSBO SALARY FICA	7,187.28	597.32	0.00	0.00	3,113.42	4,073.86	56.68
I.M.R.F./Soc. Sec. Fund	52510214	CSBO MEDICARE	1,680.72	139.70	0.00	0.00	399.22	1,281.50	76.25
I.M.R.F./Soc. Sec. Fund	52525212	BOOKKEEPER IMRF	20,128.56	1,605.50	0.00	0.00	6,677.49	13,451.07	66.83
I.M.R.F./Soc. Sec. Fund	52525213	BOOKKEEPER FICA	11,949.12	981.70	0.00	0.00	3,900.51	8,048.61	67.36
I.M.R.F./Soc. Sec. Fund		BOOKKEEPER MEDICARE	2,794.56	229.58	0.00	0.00	912.25	1,882.31	67.36
I.M.R.F./Soc. Sec. Fund	52540212	CUSTODIAN IMRF	2,405.28	185.93	0.00	0.00	1,271.49	1,133.79	47.14
I.M.R.F./Soc. Sec. Fund		CUSTODIAN IMRF	56,540.88	4,801.32	0.00	0.00	13,127.22	43,413.66	76.78
I.M.R.F./Soc. Sec. Fund	525402122	CUSTODIAN IMRF S.C.	0.00	0.00	0.00	0.00	0.00	0.00	0.00
I.M.R.F./Soc. Sec. Fund	52540213	CUSTODIAN FICA	1,454.64	116.44	0.00	0.00	758.56	696.08	47.85
I.M.R.F./Soc. Sec. Fund		CUSTODIAN FICA	35,878.32	3,067.87	0.00	0.00	8,545.93	27,332.39	76.18
I.M.R.F./Soc. Sec. Fund	525402132	CUSTODIAN FICA S.C.	1,933.92	0.00	0.00	0.00	1,598.64	335.28	17.34
I.M.R.F./Soc. Sec. Fund	50-2540-	CUSTODIANS SALARY	340.32	27.25	0.00	0.00	177.50	162.82	47.84
I.M.R.F./Soc. Sec. Fund		CUSTODIANS MEDICARE	8,390.88	717.45	0.00	0.00	2,043.49	6,347.39	75.65

Expenditure Report

Fiscal Year: 2021-2022
Month: March

COUNTY OF GRUNDY SCHOOL DIST 111

Fund Description	Account	Account Description	Revised Budget	MTD Activity	Encumbrance	Pending Activity	Available Funds	Year to Date Activity	Percent of Budget Used
I.M.R.F./Soc. Sec. Fund		CUSTODIAN MEDICARE	452.16	0.00	0.00	0.00	373.75	78.41	17.34
I.M.R.F./Soc. Sec. Fund	52541212	SUMMER CUSTODIAN	0.00	0.00	0.00	0.00	0.00	0.00	0.00
I.M.R.F./Soc. Sec. Fund	52541213	SUMMER CUSTODIAN FICA	0.00	0.00	0.00	0.00	-538.97	538.97	0.00
I.M.R.F./Soc. Sec. Fund		SUMMER CUSTODIAN	0.00	0.00	0.00	0.00	-126.04	126.04	0.00
I.M.R.F./Soc. Sec. Fund	52550212	TRANS SECY IMRF	11,863.44	599.24	0.00	0.00	7,743.16	4,120.28	34.73
I.M.R.F./Soc. Sec. Fund		BUS DRIVER IMRF	0.00	348.03	0.00	0.00	-2,659.12	2,659.12	0.00
I.M.R.F./Soc. Sec. Fund		BUS DRIVER OOD ROUTE	51,182.88	4,019.50	0.00	0.00	12,339.09	38,843.79	75.89
I.M.R.F./Soc. Sec. Fund		BUS DRIVER REG ROUTE	48,605.04	4,128.46	0.00	0.00	10,225.90	38,379.14	78.96
I.M.R.F./Soc. Sec. Fund		BOOKKEEPER IMRF	678.00	54.58	0.00	0.00	175.26	502.74	74.15
I.M.R.F./Soc. Sec. Fund		BUS AID OOD IMRF	3,065.04	394.62	0.00	0.00	-558.22	3,623.26	118.21
I.M.R.F./Soc. Sec. Fund		FULL TIME DRIVER IMRF	3,420.96	668.65	0.00	0.00	-1,803.87	5,224.83	13052.73
I.M.R.F./Soc. Sec. Fund	52550213	TRANS SECY FICA	7,139.52	373.01	0.00	0.00	4,621.88	2,517.64	35.26
I.M.R.F./Soc. Sec. Fund		50 E 2550 2130 00 300	0.00	240.77	0.00	0.00	-1,717.32	1,717.32	0.00
I.M.R.F./Soc. Sec. Fund		BUS DRIVER OOD ROUTE	31,099.92	2,644.34	0.00	0.00	6,690.89	24,409.03	78.49
I.M.R.F./Soc. Sec. Fund		BUS DRIVER REG ROUTE	36,584.16	2,918.12	0.00	0.00	10,496.77	26,087.39	71.31
I.M.R.F./Soc. Sec. Fund		BOOKKEEPER FICA	387.84	31.78	0.00	0.00	98.58	289.26	74.58
I.M.R.F./Soc. Sec. Fund		BUS AID OOD FICA	2,763.36	286.46	0.00	0.00	-176.93	2,940.29	106.40
I.M.R.F./Soc. Sec. Fund		FULL TIME DRIVER FICA	1,998.00	412.74	0.00	0.00	-1,135.07	3,133.07	156.81
I.M.R.F./Soc. Sec. Fund		TRANS SECY MEDICARE	1,669.92	87.20	0.00	0.00	1,081.36	588.56	35.24
I.M.R.F./Soc. Sec. Fund		BUS DRIVER MEDICARE	0.00	56.30	0.00	0.00	-401.67	401.67	0.00
I.M.R.F./Soc. Sec. Fund		BUS DRIVER OOD ROUTE	7,272.72	618.45	0.00	0.00	1,564.29	5,708.43	78.49
I.M.R.F./Soc. Sec. Fund		BUS DRIVER REG ROUTE	8,556.72	682.61	0.00	0.00	2,455.25	6,101.47	71.31
I.M.R.F./Soc. Sec. Fund		BOOKKEEPER MEDICARE	90.72	7.44	0.00	0.00	23.04	67.68	74.60
I.M.R.F./Soc. Sec. Fund		BUS AID OOD MEDICARE	646.08	67.00	0.00	0.00	-41.57	687.65	106.43

Expenditure Report

Fiscal Year: 2021-2022
Month: March

COUNTY OF GRUNDY SCHOOL DIST 111

Fund Description	Account	Account Description	Revised Budget	MTD Activity	Encumbrance	Pending Activity	Available Funds	Year to Date Activity	Percent of Budget Used
I.M.R.F./Soc. Sec. Fund		FULL TIME DRIVER	467.28	96.51	0.00	0.00	-265.42	732.70	156.80
I.M.R.F./Soc. Sec. Fund	52554212	BUS MECHANIC IMRF	11,887.68	795.08	0.00	0.00	4,453.78	7,433.90	62.53
I.M.R.F./Soc. Sec. Fund		TRANS DIRECTORS IMRF	7,688.88	618.86	0.00	0.00	4,825.44	2,863.44	37.24
I.M.R.F./Soc. Sec. Fund	52554213	BUS MECHANIC FICA	6,750.72	439.46	0.00	0.00	2,132.71	4,618.01	68.41
I.M.R.F./Soc. Sec. Fund		TRANS DIRECTORS FICA	4,577.04	381.36	0.00	0.00	2,966.94	1,610.10	35.18
I.M.R.F./Soc. Sec. Fund		BUS MECHANIC MEDICARE	1,578.72	102.78	0.00	0.00	744.03	834.69	52.87
I.M.R.F./Soc. Sec. Fund		TRANS DIRECTORS	1,070.40	89.18	0.00	0.00	528.78	541.62	50.60
I.M.R.F./Soc. Sec. Fund	52632212	INTERNAL INFO IMRF	2,851.92	216.52	0.00	0.00	759.07	2,092.85	73.38
I.M.R.F./Soc. Sec. Fund	52632213	INTERNAL INFO FICA	1,523.76	118.74	0.00	0.00	394.35	1,129.41	74.12
I.M.R.F./Soc. Sec. Fund	52632214	INTERNAL INFO MEDICARE	356.40	27.80	0.00	0.00	92.18	264.22	74.14
I.M.R.F./Soc. Sec. Fund	52633212	PUBLIC INFO IMRF	7,350.96	653.14	0.00	0.00	1,504.02	5,846.94	14079.54
I.M.R.F./Soc. Sec. Fund	52633213	PUBLIC INFO FICA	4,446.48	388.58	0.00	0.00	919.01	3,527.47	79.33
I.M.R.F./Soc. Sec. Fund		PUBLIC INFO MEDICARE	1,039.92	90.88	0.00	0.00	214.93	824.99	79.33
I.M.R.F./Soc. Sec. Fund	53200212	WELLNESS CENTER IMRF	0.00	0.00	0.00	0.00	0.00	0.00	0.00
I.M.R.F./Soc. Sec. Fund	53200213	WELLNESS CENTER	0.00	0.00	0.00	0.00	0.00	0.00	0.00
I.M.R.F./Soc. Sec. Fund	532002131	WELLNESS CENTER	0.00	0.00	0.00	0.00	0.00	0.00	0.00
I.M.R.F./Soc. Sec. Fund	53200214	WELLNESS CENTER	0.00	0.00	0.00	0.00	0.00	0.00	0.00
I.M.R.F./Soc. Sec. Fund	50-4100-	TITLE I SALARY (RM)	0.00	0.00	0.00	0.00	0.00	0.00	0.00
I.M.R.F./Soc. Sec. Fund	50-4100-	TITLE I SALARY (FR)	0.00	0.00	0.00	0.00	0.00	0.00	0.00
I.M.R.F./Soc. Sec. Fund	54120214	SPEC ED HB MEDICARE	0.00	0.00	0.00	0.00	0.00	0.00	0.00
I.M.R.F./Soc. Sec. Fund	50-481-212-	IMRF (RM)	0.00	0.00	0.00	0.00	0.00	0.00	0.00
I.M.R.F./Soc. Sec. Fund	50-481-212-	IMRF (RM)	0.00	0.00	0.00	0.00	0.00	0.00	0.00
I.M.R.F./Soc. Sec. Fund	50-481-213-	IMRF (FR)	0.00	0.00	0.00	0.00	0.00	0.00	0.00
I.M.R.F./Soc. Sec. Fund	50-481-213-	IMRF (FR)	0.00	0.00	0.00	0.00	0.00	0.00	0.00

Expenditure Report

Fiscal Year: 2021-2022
Month: March

COUNTY OF GRUNDY SCHOOL DIST 111

Fund Description	Account	Account Description	Revised Budget	MTD Activity	Encumbrance	Pending Activity	Available Funds	Year to Date Activity	Percent of Budget Used
50 - -----			925,096.56	76,753.02	0.00	0.00	241,836.52	683,260.04	
5- - -----			925,096.56	76,753.02	0.00	0.00	241,836.52	683,260.04	
Capital Projects Fund or	62530500	FAC ACQ & CONSTR SERV	0.00	0.00	0.00	0.00	0.00	0.00	0.00
Capital Projects Fund or	62530501	FAC ACQ & CONSTR SERV	0.00	0.00	0.00	0.00	0.00	0.00	0.00
Capital Projects Fund or	62532390	REIMB EXPENSES	0.00	0.00	0.00	0.00	0.00	0.00	0.00
Capital Projects Fund or	62532520	TRANS BULDING	0.00	0.00	0.00	0.00	-25,000.00	25,000.00	0.00
Capital Projects Fund or	62532530	SIGNALIZATION	0.00	0.00	0.00	0.00	0.00	0.00	0.00
Capital Projects Fund or	62533316	A & E FEES/ 2011	0.00	0.00	0.00	0.00	0.00	0.00	0.00
Capital Projects Fund or	62533314	TCC CONST FEES	0.00	0.00	0.00	0.00	0.00	0.00	0.00
Capital Projects Fund or	62533310	A & E FEES/PROJECT 2279	0.00	0.00	0.00	0.00	0.00	0.00	0.00
Capital Projects Fund or	62533311	A & E FEES/PROJECT 2299	0.00	0.00	0.00	0.00	0.00	0.00	141 0.00
Capital Projects Fund or	62533312	A & E FEES/PROJECT 2386	0.00	0.00	0.00	0.00	0.00	0.00	0.00
Capital Projects Fund or	62533313	A & E FEES/PROJECT 6003	0.00	0.00	0.00	0.00	0.00	0.00	0.00
Capital Projects Fund or	62533315	A & E FEES/2009	0.00	0.00	0.00	0.00	0.00	0.00	0.00
Capital Projects Fund or	62533320	A & E FEES/PROJECT	0.00	0.00	0.00	0.00	0.00	0.00	0.00
Capital Projects Fund or	62533318	LEGAL SERVICES	0.00	0.00	0.00	0.00	0.00	0.00	0.00
Capital Projects Fund or	62533319	PROF TECH SERV	0.00	0.00	0.00	0.00	0.00	0.00	0.00
Capital Projects Fund or	62533390	OTHER PUR SERV-STRC	0.00	0.00	0.00	0.00	-2,841.00	2,841.00	0.00
Capital Projects Fund or	62533391	OTHER PUR SERV-STRC	0.00	0.00	0.00	0.00	0.00	0.00	0.00
Capital Projects Fund or	62535315	BLDRS RISK COVERAGE	0.00	0.00	0.00	0.00	0.00	0.00	0.00
Capital Projects Fund or	62535325	CAPITAL IMPROVEMENT	5,000,000.00	0.00	35,723.58	0.00	4,771,933.64	192,342.78	3.85
Capital Projects Fund or	62535323	BLEACHER REPAIR &	0.00	0.00	0.00	0.00	0.00	0.00	0.00
Capital Projects Fund or	62535324	CENTRAL PAC	0.00	0.00	0.00	0.00	0.00	0.00	0.00
Capital Projects Fund or	62535523	BLEACHER CAPITAL	0.00	0.00	0.00	0.00	0.00	0.00	0.00

Expenditure Report

Fiscal Year: 2021-2022
Month: March

COUNTY OF GRUNDY SCHOOL DIST 111

Fund Description	Account	Account Description	Revised Budget	MTD Activity	Encumbrance	Pending Activity	Available Funds	Year to Date Activity	Percent of Budget Used
Capital Projects Fund or	62535525	CAPITAL IMPROVEMENTS	0.00	0.00	0.00	0.00	-14,627.66	14,627.66	0.00
Capital Projects Fund or	62535554	CONTINGENCY COSTS	0.00	0.00	0.00	0.00	0.00	0.00	0.00
Capital Projects Fund or	62535555	CONSTR COSTS #6003	0.00	0.00	0.00	0.00	0.00	0.00	0.00
Capital Projects Fund or	62535559	CONSTRUCTION COST	0.00	0.00	0.00	0.00	0.00	0.00	0.00
Capital Projects Fund or	62535558	TRANSPORTATION COST	0.00	0.00	0.00	0.00	0.00	0.00	0.00
Capital Projects Fund or	62535558	CONSTRUCTION COST	0.00	0.00	0.00	0.00	0.00	0.00	0.00
Capital Projects Fund or	62535550	CONSTR COSTS #2279	0.00	0.00	0.00	0.00	0.00	0.00	0.00
Capital Projects Fund or	62535551	CONSTR COSTS #2299	0.00	0.00	0.00	0.00	0.00	0.00	0.00
Capital Projects Fund or	62535552	CONTINGENCY COSTS	0.00	0.00	0.00	0.00	0.00	0.00	0.00
Capital Projects Fund or	62535553	CONTINGENCY COSTS	0.00	0.00	0.00	0.00	0.00	0.00	0.00
Capital Projects Fund or	62535556	FF & E COSTS #6003	0.00	0.00	0.00	0.00	0.00	0.00	142 0.00
Capital Projects Fund or	62535557	CONSTR COSTS/2009	0.00	0.00	0.00	0.00	0.00	0.00	0.00
Capital Projects Fund or	68140	TRANS OF INTEREST	0.00	0.00	0.00	0.00	0.00	0.00	0.00
Capital Projects Fund or	68180611	PERM TRANS FROM W/C	0.00	0.00	0.00	0.00	0.00	0.00	0.00
60 - -----			5,000,000.00	0.00	35,723.58	0.00	4,729,464.98	234,811.44	
6- - -----			5,000,000.00	0.00	35,723.58	0.00	4,729,464.98	234,811.44	
Working Cash Fund	78180611	PERM TRANS FROM W/C	0.00	0.00	0.00	0.00	0.00	0.00	0.00
Working Cash Fund	78180710	PERM TRANS OF W/C-	0.00	0.00	0.00	0.00	0.00	0.00	0.00
Working Cash Fund	78990	OTHER USES NOT	0.00	0.00	0.00	0.00	0.00	0.00	0.00
70 - -----			0.00	0.00	0.00	0.00	0.00	0.00	
7- - -----			0.00	0.00	0.00	0.00	0.00	0.00	
Tort Immunity and	81130100	CAMPUS MONITOR	50,000.00	19,173.53	0.00	0.00	-110,547.31	160,547.31	321.09
Tort Immunity and	81130101	NURSE SALARY	45,000.00	443.54	0.00	0.00	41,654.09	3,345.91	7.44
Tort Immunity and	81130102	DEANS SALARY	50,000.00	4,668.20	0.00	0.00	8,447.58	41,552.42	83.10

Expenditure Report

Fiscal Year: 2021-2022
Month: March

COUNTY OF GRUNDY SCHOOL DIST 111

Fund Description	Account	Account Description	Revised Budget	MTD Activity	Encumbrance	Pending Activity	Available Funds	Year to Date Activity	Percent of Budget Used
Tort Immunity and		80 E 1130 2110 00 300	0.00	440.21	0.00	0.00	-2,648.60	2,648.60	0.00
Tort Immunity and		DIST 111 GROUP MEDICAL	24,000.00	4,777.93	0.00	0.00	-26,444.74	50,444.74	210.19
Tort Immunity and		80 E 1130 2220 00 300	0.00	7,339.58	0.00	0.00	-43,973.58	43,973.58	0.00
Tort Immunity and		80 E 1130 2220 00 300	0.00	0.44	0.00	0.00	-2.62	2.62	0.00
Tort Immunity and		80 E 1130 2220 00 300	0.00	1,600.34	0.00	0.00	-9,602.02	9,602.02	0.00
Tort Immunity and		DIST 111 GROUP DENTAL	27,043.44	397.38	0.00	0.00	10,794.12	16,249.32	60.09
Tort Immunity and		80 E 1130 2230 00 300	0.00	28.92	0.00	0.00	-171.30	171.30	0.00
Tort Immunity and			0.00	0.00	0.00	0.00	0.00	0.00	0.00
Tort Immunity and			0.00	0.00	0.00	0.00	0.00	0.00	0.00
Tort Immunity and	82310200	BOARD OF ED-OTHER	1,780.58	0.00	0.00	0.00	1,780.58	0.00	0.00
Tort Immunity and	82310318	ATTORNEY FEES	20,000.00	6,845.00	0.00	368.00	-83,323.56	102,955.56	14514.78
Tort Immunity and	82362381	WORK COMP PREMIUMS	31,000.00	15,494.00	0.00	0.00	-92,952.00	123,952.00	399.85
Tort Immunity and	82363380	UNEMPLOYMENT INS	0.00	0.00	0.00	0.00	0.00	0.00	0.00
Tort Immunity and	82364382	PROPERTY INLAND	62,000.00	0.00	0.00	0.00	62,000.00	0.00	0.00
Tort Immunity and	82364383	GEN LIABILITY INS	180,000.00	0.00	0.00	0.00	-54,304.00	234,304.00	130.17
Tort Immunity and	82364384	SLEO/SMM	0.00	0.00	0.00	0.00	0.00	0.00	0.00
Tort Immunity and	82364385	UMBRELLA	0.00	0.00	0.00	0.00	0.00	0.00	0.00
Tort Immunity and	82364386	STUDENT CATASTROPHIC	195,522.00	0.00	0.00	0.00	192,422.00	3,100.00	1.59
Tort Immunity and	82365395	SAFETY/INSURANCE	0.00	0.00	0.00	1,673.80	-18,055.80	16,382.00	0.00
Tort Immunity and	82365390	EVENT SECURITY P.S.	15,000.00	4,093.76	0.00	0.00	-5,985.53	20,985.53	139.90
Tort Immunity and	82365391	SRO	2,834.67	0.00	0.00	0.00	0.00	2,834.67	100.00
Tort Immunity and	82365393	BUILD REPAIR MAINT/FIRE	16,500.00	121.50	0.00	0.00	-4,412.85	20,912.85	126.74
Tort Immunity and	82365394	BUILD REPAIR/COMM	15,000.00	0.00	0.00	0.00	15,000.00	0.00	0.00
Tort Immunity and	823653922	SRO - S.C.	95,000.00	16,221.59	0.00	0.00	15,777.14	79,222.86	83.39

Expenditure Report

Fiscal Year: 2021-2022
Month: March

COUNTY OF GRUNDY SCHOOL DIST 111

Fund Description	Account	Account Description	Revised Budget	MTD Activity	Encumbrance	Pending Activity	Available Funds	Year to Date Activity	Percent of Budget Used
Tort Immunity and	82367110	CAMPUS MONITOR SUB	250,000.00	0.00	0.00	0.00	249,913.00	87.00	0.03
Tort Immunity and	82367130	CAMPUS MON. EXTRA	4,000.00	0.00	0.00	0.00	4,000.00	0.00	0.00
Tort Immunity and	82367211	DEANS TRS	60,000.00	0.00	0.00	0.00	60,000.00	0.00	0.00
Tort Immunity and		DEANS TRS	1,037.52	0.00	0.00	0.00	-220.10	1,257.62	121.21
Tort Immunity and	80-2367-	DEANS SALARY (BCE-P)	18,715.76	0.00	0.00	0.00	-3,669.79	22,385.55	119.61
Tort Immunity and		NURSE GROUP INS	0.22	0.00	0.00	0.00	-0.71	0.93	422.73
Tort Immunity and		DEANS INS	5,500.00	0.00	0.00	0.00	386.11	5,113.89	92.98
Tort Immunity and		DEANS DENTAL	80,000.00	0.00	0.00	0.00	79,905.38	94.62	0.12
Tort Immunity and	82542301	BUILDING SECURITY	0.00	0.00	0.00	0.00	0.00	0.00	0.00
Tort Immunity and	82542320	BUILDING INSPECTIONS	0.00	0.00	0.00	0.00	-8,795.00	8,795.00	0.00
Tort Immunity and	82546410	SECURITY SUPPLIES	27,000.00	0.00	0.00	0.00	-14,356.49	41,356.49	1453.17
Tort Immunity and	825464102	SECURITY SUPPLIES	25,000.00	0.00	0.00	0.00	25,000.00	0.00	0.00
Tort Immunity and	82546540	SECURITY EQUIPMENT	5,000.00	0.00	0.00	0.00	-75,226.97	80,226.97	1,604.54
Tort Immunity and	825465402	SECURITY EQUIPMENT	15,000.00	0.00	0.00	0.00	15,000.00	0.00	0.00
80 - -----			1,321,934.19	81,645.92	0.00	2,041.80	227,387.03	1,092,505.36	
8- - -----			1,321,934.19	81,645.92	0.00	2,041.80	227,387.03	1,092,505.36	
Fire Prevention & Safety	92542310	LIFE SAFETY A & E	0.00	0.00	0.00	0.00	0.00	0.00	0.00
Fire Prevention & Safety	92542311	SAFETY CONSULTATION	0.00	0.00	0.00	0.00	0.00	0.00	0.00
Fire Prevention & Safety	92542312	GAVC PROJECT	0.00	0.00	0.00	0.00	0.00	0.00	0.00
Fire Prevention & Safety	92542530	LIFE SAFETY REPAIRS	2,000,000.00	0.00	0.00	0.00	2,000,000.00	0.00	0.00
Fire Prevention & Safety	92542531	LIFE SAFETY - ROOFING	0.00	0.00	0.00	0.00	0.00	0.00	0.00
90 - -----			2,000,000.00	0.00	0.00	0.00	2,000,000.00	0.00	
9- - -----			2,000,000.00	0.00	0.00	0.00	2,000,000.00	0.00	
Account Monthly Activity Grand Totals:			62,147,469.11	3,617,628.63	4,343,627.21	1,299,609.53	15,737,044.68	40,767,187.69	

Input Report Date 3/31/2022

Cash and Investments Report

	Education	Oper/ Maint.	Debt Service *	Transporation	IMRF/ Soc Sec	Capital **	Working Cash	Tort	Life Safety	Total	Fund 11 Activities	Total Funds
Checking	\$507,708.93	\$78,477.99	\$48,998.55	\$64,381.90	\$100,989.25	\$230,960.77	\$82,379.54	\$64,330.80	\$25,595.40	\$1,203,823.13	\$506,568.96	\$1,710,392.09
Food Service Account	\$1,034,779.23									\$1,034,779.23	0	\$1,034,779.23
Imprest	\$32,237.65	\$100.00		\$15,174.00						\$47,511.65	0	\$47,511.65
Insurance Account	\$1,680,570.18	\$303,229.62		\$35,674.56				(35269.48)		\$1,984,204.88	0	\$1,984,204.88
PMA Cash Account	\$1,254,272.73	\$1,917,016.72	(\$210,658.06)	\$3,268,826.91	(\$57,708.45)	\$225,000.00	\$2,850,566.00	\$1,528,633.69	\$1,565,480.31	\$12,341,429.85	0	\$12,341,429.85
IP/TIP	\$2,159,663.16	\$1,251,058.06	\$0.00	\$0.00	\$536,198.01	\$0.00	\$204,143.59	\$0.00	\$0.00	\$4,151,062.82	0	\$4,151,062.82
Total Cash accounts	\$6,669,231.88	\$3,549,882.39	(\$161,659.51)	\$3,384,057.37	\$579,478.81	\$455,960.77	\$3,137,089.13	\$1,557,695.01	\$1,591,075.71	\$20,762,811.56	\$506,568.96	\$21,269,380.52
PMA Investments	\$6,962,711.32	\$2,128,032.84	\$3,546,484.76	\$1,222,279.51	\$366,033.38	\$377,589.15	\$12,899,163.39	\$733,733.74	\$738,183.35	\$28,974,211.44	361,386.94	29,335,598.38
PMA 101 Investments	\$6,682,141.40	\$1,450,463.32	\$3,262,412.75	\$688,011.10	\$347,363.54	\$325,000.00	\$263,709.51	\$483,492.69	\$287,087.40	\$13,789,681.71	-	\$13,789,681.71
PMA 62 (Working Cash)						\$0.00				\$0.00	-	\$0.00
PMA 202						\$0.00				\$0.00	-	\$0.00
PMA 203 - 2006 Bond			\$129,326.72							\$129,326.72	-	\$129,326.72
PMA 65 (Capital)										\$0.00	-	\$0.00
US Bank	\$0.00									\$0.00	-	\$0.00
PMA 205 Working Cash							\$12,555,812.20			\$12,555,812.20	-	\$12,555,812.20
PMA 68										\$0.00	0	\$0.00
PMA 104 - General Reserve	\$280,569.92	\$677,569.52	\$154,745.29	\$534,268.41	\$18,669.84	\$52,589.15	\$79,641.68	\$250,241.05	\$451,092.67	\$2,499,387.53	0	\$2,499,387.53
PMA 208 - Health Life Safety									\$3.28	\$3.28	0	\$3.28
PMA 209 - Capital						\$5,771,269.47				\$5,771,269.47	0	\$5,771,269.47
Private Bank Investments	\$624,507.48	\$1,469.34	\$108,550.07	\$148,580.13	\$7,059.52	\$0.00	\$0.00	\$0.00	\$0.00	\$890,166.54	0	\$890,166.54
PMA 103 - Coady Scholarship										\$0.00	361,386.94	\$361,386.94
Total Investments	\$7,587,218.80	\$2,129,502.18	\$3,655,034.83	\$1,370,859.64	\$373,092.90	\$6,148,858.62	\$12,899,163.39	\$733,733.74	\$738,183.35	\$35,635,647.45	361,386.94	\$35,997,034.39
Total Cash & Investment:	\$14,256,450.68	\$5,679,384.57	\$3,493,375.32	\$4,754,917.01	\$952,571.71	\$6,604,819.39	\$16,036,252.52	\$2,291,428.75	\$2,329,259.06	\$56,398,459.01	\$867,955.90	\$57,266,414.91



PRICE AND BILLING

Fee For Services and Engagement Letter

We, the undersigned, being a principal with the below-named auditing firm, accept the specifications for auditing services and agree to perform the outlined auditing services for the amount(s) indicated below:

Fiscal Year	Annual General Audit Services	Single Audit*	Hourly Consultation Fee
2021-22	\$17,250	\$4,500	\$120
2022-23	\$17,800	\$4,600	\$125
2023-24	\$18,300	\$4,700	\$130

Term is 1 year with District Options for Years 2 and 3

* L&A notes charge is for 2 Major Programs. 1 Major Program will be \$3,000 and any additional Program will be additional \$1,500 per Program.

Company Name: Lauterbach & Amen, LLP

Address: 668 N. River Road

City: Naperville State: IL Zip: 60563

Telephone: 630.393.1483 Fax: 630.821.0189

Representative and Title: Matt R Beran, Partner

Signature:  Date: April 11, 2022



MINOOKA COMMUNITY HIGH SCHOOL

District #111 mchs.net

Mission: Strengthen *Mastery*, *Collaboration*, *High Expectations*, and *Success for All Students*.

April 6, 2022

To: Board of Education
Dr. Kenny Lee

From: John Troy

RE: Leasing Levy – Abating from Education Fund to Capital Fund

Per the last Audit the district has \$2,568,041 dollars of restricted use funds built up from the leasing levy in past years. The school code allows the district by resolution to abate the leasing levy funds to any other fund (see 105 ILCS 5/17-2.2C)

The amount of restricted exceeds the needs of the district for leasing expenditures. The administration recommendation is to abate \$2,000,000 dollars of restricted leasing levy funds, currently held in the education fund, to the capital fund. These funds will be used for our capital improvement projects. The leasing levy will continue to be levied after the abatement/transfer of funds, i.e. we are not abolishing the leasing levy.

If this meets with the Board’s approval a resolution to this effect will be prepared and placed on the agenda at the regular Board meeting.

Balances:

	Before Transfer	After Transfer
Ed Fund	\$14,256,450	\$12,256,450
Capital Fund	\$6,604,819	\$8,604,819

Fund balances before and after transfer will continue to comply with the Board’s fund balance policy (4:20)

FY 2021 Audit – page 31

NOTE 4: PROPERTY TAXES – (Continued)

Leasing - Cash receipts and the related cash disbursements of this restricted tax levy are accounted for in the Educational Fund. A portion of the Educational Fund’s equity represents the excess of cumulative receipts over cumulative disbursements of this levy, which is restricted for future Leasing cash disbursements in accordance with Section 105 ILCS 5/17-2.2C of the *Illinois Compiled Statutes*.

Restricted Fund Balance - July 1, 2020	\$ 2,614,355
Revenues Received	486,582
Expenditures Disbursed	<u>532,896</u>
Restricted Fund Balance - June 30, 2021	<u>\$ 2,568,041</u>

Illinois Statute – Leasing Levy

(105 ILCS 5/17-2.2c) (from Ch. 122, par. 17-2.2c)

Sec. 17-2.2c. Tax for leasing educational facilities or computer technology or both, and for temporary relocation expense purposes. The school board of any district, by proper resolution, may levy an annual tax, in addition to any other taxes and not subject to the limitations specified elsewhere in this Article, not to exceed .05% upon the value of the taxable property as equalized or assessed by the Department of Revenue, for the purpose of leasing educational facilities or computer technology or both, and, in order to repay the State all moneys distributed to it for temporary relocation expenses of the district, may levy an annual tax not to exceed .05% upon the value of the taxable property as equalized or assessed by the Department of Revenue for a period not to exceed 7 years for the purpose of providing for the repayment of moneys distributed for temporary relocation expenses of the school district pursuant to Section 2-3.77.

The tax rate limit specified by this Section with respect to an annual tax levied for the purpose of leasing educational facilities or computer technology or both may be increased to .10% upon the approval of a proposition to effect such increase by a majority of the electors voting on that proposition at a regular scheduled election. Such proposition may be initiated by resolution of the school board and shall be certified by the secretary to the proper election authorities for submission in accordance with the general election law.

The tax rate limit specified in this Section may also be increased as provided in Section 17-2.2e.

The district is authorized to pledge any tax levied pursuant to this Section for the purpose of leasing educational facilities or computer technology or both to secure the payment of any lease, lease-purchase agreement, or installment purchase agreement entered into by the district for such purpose.

For the purposes of this Section, "leasing of educational facilities or computer technology or both" includes any payment with respect to a lease, lease-purchase agreement, or installment purchase agreement to acquire or use buildings, rooms, grounds, and appurtenances to be used by the district for the use of schools or for school administration purposes and all equipment, fixtures, renovations, and improvements to existing facilities of the district necessary to accommodate computers, as well as computer hardware and software.

Any school district may abolish or abate its fund for leasing educational facilities or computer technology or both and for temporary relocation expense purposes upon the adoption of a resolution so providing and upon a determination by the school board that the moneys in the fund are no longer needed for leasing educational facilities or computer technology or both or for temporary relocation expense purposes. The resolution shall direct the transfer of any balance in the fund to another school district fund or funds immediately upon the resolution taking effect. Thereafter, any outstanding taxes of the school district levied pursuant to this Section shall be collected and paid into the fund or funds as directed by the school board. Nothing in this Section shall prevent a school district that has abolished or abated the fund from again creating a fund for leasing educational facilities and for temporary relocation expense purposes in the manner provided in this Section.

(Source: P.A. 99-908, eff. 12-16-16.)

Revised Finaning Proposals

	Company	Purchase Price	Guaranteed Buy Back	Rate	Quoted Lease- 5 years	Bus	Engine	Miles allowed	Overage	Annual Cost Lease (using lowest financing option)	5 Year Lease
Kansas State Bank	Midwest Bus Sales	\$ 105,434.00	\$40,191	2.98%	15,108	Thomas	Cummins	\$18,953.00	.35/mi	\$ 151,078.30	\$ 755,391.50
American Capital	Midwest Bus Sales	\$ 105,434.00	\$40,191	2.92%	14,969	Thomas	Cummins	\$18,953.00	.35/mi	\$ 149,688.14	\$ 748,440.70

*Recommendation: Midwest Bus Sales, Thomas Cummins; financing option through American Capital

Original Proposals (approved at the 2/28/2022 BOE Meeting)

	Company	Purchase Price	Guaranteed Buy Back	Quoted Lease- 5 years	Bus	Engine	Miles allowed	Overage	Annual Cost Lease (using lowest financing option)	5 Year Lease
Option 1	Midwest Bus Sales	\$ 105,434.00	\$39,786	16,970/14,615	Thomas	Cummins	\$18,953.00	.35/mi	\$ 146,150.00	\$ 730,750.00
Option 2	Central States	\$ 104,202.00	\$27,500		Bluebird	Cummins	\$18,000.00	.35/mi	\$ 172,300.00	\$ 861,500.00
Option 3	Midwest Transit	\$ 97,826.00	\$38,000		International	Cummins	\$17,000.00	.35/mi	\$ 138,810.00	\$ 694,050.00
Option 4	Midwest Bus Sales	\$ 93,194.00	\$35,167		Thomas	Detroit DD5	\$18,953.00	.35/mi	\$ 129,180.00	\$ 645,900.00

*Recommendation: Midwest Bus Sales, Thomas Cummins; financing option #2 through Kansas State Bank

LAND CASH REQUEST: KENDALL COUNTY LAND CASH ORDINANCE

MINOOKA COMMUNITY HIGH SCHOOL DISTRICT #111 HEREBY REQUESTS KENDALL COUNTY TO RELEASE FUNDS IN THE AMOUNT OF \$454.69 ACQUIRED UNDER THE KENDALL COUNTY LAND CASH ORDINANCE ON BEHALF OF SAID SCHOOL DISTRICT # 111 FOR THE PURPOSE OF:

(DESIGNATE SCHOOL BUILDINGS AND NATURE OF PROJECT)

Improvements to the Minooka Community High School District #111 school buildings. Funds will be applied to renovations at Central Campus.

MINOOKA COMMUNITY HIGH SCHOOL DISTRICT #111 ACKNOWLEDGES THAT USE OF SAID FUNDS REQUESTED UNDER THE KENDALL COUNTY LAND CASH ORDINANCE WILL BE USED IN ACCORDANCE WITH THE STIPULATIONS, LIMITATIONS, AND REQUIREMENTS OF THE KENDALL COUNTY LAND CASH ORDINANCE, 1995.

Board of Education, Secretary

Date

Superintendent

Date

APPROVAL:

Grundy-Kendall Regional Superintendent

Date

Kendall County Treasurer

Date

RESOLUTION AUTHORIZING LAND CASH REQUEST

WHEREAS, the County of Kendall Land Cash Ordinance authorizes the collection of land and/or cash from developers for the purpose of building and/or improving recreational parks and schools;

WHEREAS, the Kendall County Treasurer has informed the District that it has \$454.69 balance in this fund; and

WHEREAS, the Board of Education finds that it is financially prudent to receive said funds from Treasurer to be used for improvements to the District’s schools that serve residents of Kendall County.

NOW THEREFORE BIT IT RESOLVED by the Board of Education of Minooka Community High School District No. 111 that the request for land cash balance of \$454.69 is approved and the administration is directed to forward said request and this resolution to the Regional Superintendent for Schools and the Kendall County Treasurer. The administration is further directed to use said funds for the improvement of the district schools serving Kendall County.

ADOPTED this 20th day of April, 2022.

AYEs: __

NAYs: __

ABSENT: __

President, Board of Education

Secretary, Board of Education



Office of Jill Ferko
Kendall County Treasurer & Collector
111 West Fox Street
Yorkville, IL 60560

(630) 553-4124 Phone
(630) 553-4117 Fax

April 1, 2022

Minooka High School District #111
John Troy, Director of Business
26655 West Eames Street
Channahon, IL 60410

Dear Mr. Troy:

As of March 31, 2022 the balance of Land Cash Funds for your District is \$454.69. To request the release of these funds an application must be submitted to the Regional Superintendent of Schools. We have enclosed a form for your convenience.

We intend to report your balance on a quarterly basis or you may call at any time.

Sincerely,

A handwritten signature in cursive script that reads "Jill Ferko".

Jill Ferko
Kendall County Treasurer & Collector