

LINCOLNWOOD SCHOOL DISTRICT 74  
BOARD OF EDUCATION  
Finance Committee Meeting AGENDA  
Thursday, April 18, 2024 at **5:30 PM**

BOARD OF EDUCATION  
Kevin Daly, *President*  
Peter D. Theodore, *Vice President*  
John P. Vranas, *Secretary*  
Myra A. Foutris  
Jay Oleniczak  
Rupal Shah Mandal

ADMINISTRATION  
Dr. David L. Russo, *Superintendent of Schools*  
Dr. Dominick M. Lupo, *Assistant Superintendent for Curriculum and Instruction*  
Courtney Whited, *Business Manager/CSBO*

*Agenda of the Finance Committee Meeting of the Board of Education of Lincolnwood School District 74, Cook County, Illinois, to be held in the Marvin Garlich Administration Building  
6950 N. East Prairie Road  
Lincolnwood, Illinois 60712,  
on Thursday, April 18, 2024.*

*IN-PERSON PARTICIPATION: It is expected that all members of the Finance Committee, plus several administrators, will be physically present at the Marvin Garlich Administration Building located at 6950 N. East Prairie Road, Lincolnwood, IL. The public is welcome.*

**PLEASE NOTE THE TIME ADJUSTMENT FOR THIS MEETING**

1. CALL TO ORDER/ROLL CALL

FINANCE COMMITTEE MEMBERS

- Peter D. Theodore (BOE), Chair
- Jay Oleniczak (BOE), Co-Chair
- John P. Vranas (BOE)
- Michael Bartholomew, Community Member
- Maja Kenjar, Community Member
- Steven Pawlow, Community Member
- Paul Stellatos, Community Member

ADMINISTRATORS/STAFF

- Dr. David L. Russo, Superintendent of Schools
- Dr. Dominick M. Lupo, Assistant Superintendent for Curriculum and Instruction
- Courtney Whited, Business Manager/CSBO
- Jordan Stephen, Director of Technology

2. AUDIENCE TO VISITORS

3. APPROVAL OF MINUTES

- a. Finance Committee Meeting Minutes - **MARCH 21, 2024** 3

Motion by member: \_\_\_\_\_ Seconded by: \_\_\_\_\_

4. INFORMATION/DISCUSSION: FUND BALANCE REPORT

- a. Fund Balance Report - **FEBRUARY 2024** 1 5

5. OLD BUSINESS	
6. NEW BUSINESS	
a. Final Fiscal Year 2023 Single Audit by Lauterbach & Amen, LLP	28
b. Transportation Contract Amendment 2024-25 with First Student, Inc.	42
c. LBSA Waiver Request- FY25 Facilities Rental Fees	92
d. Infinite Connections Inc. Agreement Renewal	94
e. Kings III Emergency Elevator Phone	100
f. E Rate Category II – SHI Wireless Access Points	109
g. E Rate Category I – AT&T High Speed Internet Access	117
7. <u>INFORMATION/DISCUSSION</u> : District Purchasing Update(s) - <i>Dr. David L. Russo, Dr. Dominick M. Lupo, Jordan Stephen</i>	<u>143</u>
a. Gaggle for 2024-2025	
b. Jamf for 2024-2025	
c. Formative for 2024-2025	
d. Pebble Go for 2024-2025	
8. <u>INFORMATION/DISCUSSION</u> : District Finance Update - <i>Courtney Whited, Business Manager/CSBO</i>	<u>145</u>
a. Potential partnership between SD74 and the Early Childhood Alliance	
9. ADJOURNMENT	
Motion by member: _____ Seconded by: _____	

**Dr. David L. Russo, Superintendent of Schools**

*Lincolnwood School District 74 is subject to the requirements of the Americans with Disabilities Act of 1990. Individuals with disabilities who plan to attend this meeting and who require certain accommodations in order to allow them to observe and/or participate in this meeting, or who have questions regarding the accessibility of this meeting or facility, are requested to contact the District Office at 847-675-8234 promptly to allow Lincolnwood School District 74 to make reasonable accommodations for those persons.*

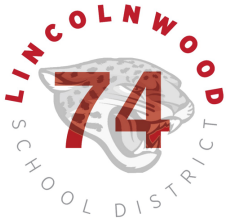

LINCOLNWOOD SCHOOL DISTRICT 74  
BOARD OF EDUCATION  
Finance Committee Meeting Minutes  
Thursday, March 21, 2024 at **6:30 PM**

BOARD OF EDUCATION  
Kevin Daly, *President*  
Rupal Shah Mandal, *Vice President*  
John P. Vranas, *Secretary*  
Maxie Boynton  
Myra A. Foutris  
Jay Oleniczak  
Peter D. Theodore

ADMINISTRATION  
Dr. David L. Russo, *Superintendent of Schools*  
Dr. Dominick M. Lupo, *Assistant Superintendent for Curriculum and Instruction*  
Courtney Whited, *Business Manager/CSBO*

*Minutes of the Finance Committee Meeting of the Board of Education of Lincolnwood School District 74,  
Cook County, Illinois, was held in the Marvin Garlich Administration Building  
6950 N. East Prairie Road, Lincolnwood, Illinois 60712, on Thursday, March 21, 2024.*

1. CALL TO ORDER/ROLL CALL

Chair Theodore called the Finance Committee meeting to order at 6:33 p.m.

FINANCE COMMITTEE MEMBERS

Peter D. Theodore (BOE), Chair  
Jay Oleniczak (BOE), Co-Chair  
John P. Vranas (BOE)  
Michael Bartholomew, Community Member

FINANCE COMMITTEE MEMBERS NOT PRESENT

Maja Kenjar, Community Member  
Steven Pawlow, Community Member  
Paul Stellatos, Community Member

ADMINISTRATORS/STAFF

Dr. David L. Russo, Superintendent of Schools  
Dr. Dominick M. Lupo, Assistant Superintendent for Curriculum and Instruction  
Courtney Whited, Business Manager/CSBO

2. AUDIENCE TO VISITORS

None

3. APPROVAL OF MINUTES

a. Finance Committee Meeting Minutes - **FEBRUARY 22, 2024**

A motion was made, seconded, and passed to approve the minutes from the February 22, 2024, Finance Committee meeting.

4. FUND BALANCE REPORT

a. Fund Balance Report - **JANUARY 2024**

Courtney Whited, Business Manager/CSBO, presented the Fund Balance Report for January 2024.

5. OLD BUSINESS

None

## 6. NEW BUSINESS

### a. 6-year | Kindergarten through Fifth Grade Math Program Adoption | Carnegie Learning, Inc. © 2014-2023

A motion was made, seconded and passed that The Finance Committee concur with the Administration's recommendation to the Board of Education to approve this contract from *Carnegie Learning, Inc. © 2014-2023* for the adoption of the K-5 math curriculum in the amount of \$233,733.12 from the 2024-2025 school year to the 2029-2030 school year.

### b. Middle School Science Curriculum Adoption – © 2024 Amplify Education, Inc

A motion was made, seconded and passed that The Finance Committee concur with the Administration's recommendation to the Board of Education to approve this Agreement from Amplify Education for the middle school science curriculum in the amount of \$67,710.20 from the 2024-2025 school year until the 2029-2030 school year.

### c. Donation from ROSE Foundation

A motion was made, seconded and passed that The Finance Committee concur with the Administration's recommendation to the Board of Education to accept the donation of \$200 and \$60 Smoothie King gift certificates from ROSE Foundation.

## 7. District Purchasing Update(s) - *Dr. David L. Russo, Dr. Dominick M. Lupo, Jordan Stephen*

### a. Genuity Renewal for 2024-2025

### b. IXL for 1st Grade

## 8. District Finance Update - *Courtney Whited, Business Manager/CSBO*

### a. SD74 FY24 Q3 Budget Review

Courtney Whited, Business Manager/CSBO, presented the SD74 FY24 Q3 Budget Review. Courtney detailed each fund's expenditures and revenues. The Committee recommended not amending the FY24 Budget.

## 9. ADJOURNMENT

A motion was made, seconded and passed to adjourn the Finance Committee meeting. The Finance Committee meeting was adjourned at 7:09 p.m.

The next Finance Committee meeting will be Thursday, April 18, 2024 at 6:30 p.m. The public is welcome.

---

Peter D. Theodore, Chair

---

Jay Oleniczak, Co-chair

Lincolnwood School District 74

Fund Balances

Fiscal Year: 2023-2024

Month: February

Year: 2024

Fund Type:

Include Cash Balance

FY End Report

<u>Fund</u>	<u>Description</u>	<u>Beginning Balance</u>	<u>Revenue</u>	<u>Expense</u>	<u>Transfers</u>	<u>Fund Balance</u>
10	EDUCATIONAL	\$14,185,013.40	\$15,688,038.78	(\$12,315,551.50)	\$0.00	\$17,557,500.68
20	OPERATIONS & MAINTENANCE	\$4,215,122.81	\$1,317,892.92	(\$1,698,324.66)	(\$2,000,000.00)	\$1,834,691.07
30	DEBT SERVICE	\$805,374.06	\$1,104,520.87	(\$1,515,375.00)	\$0.00	\$394,519.93
40	TRANSPORTATION	\$1,742,536.99	\$975,116.70	(\$915,579.66)	\$0.00	\$1,802,074.03
50	MUNICIPAL RETIREMENT	\$0.00	\$0.00	\$0.00	\$0.00	\$0.00
51	IMRF	\$808,701.76	\$117,429.67	(\$117,166.30)	\$0.00	\$808,965.13
52	SOCIAL SECURITY AND MEDICARE	\$405,685.77	\$234,003.78	(\$217,535.84)	\$0.00	\$422,153.71
60	CAPITAL PROJECTS	\$4,594,191.64	\$653,618.97	(\$1,698,132.87)	\$2,000,000.00	\$5,549,677.74
70	WORKING CASH	\$586,340.43	\$7,241.39	\$0.00	\$0.00	\$593,581.82
80	TORT IMMUNITY	\$439,581.77	\$132,983.91	(\$8,655.00)	\$0.00	\$563,910.68
90	FIRE PREVENTION & SAFETY	\$2,946,220.34	\$170,231.72	(\$1,300,230.69)	\$0.00	\$1,816,221.37
99	LINCOLNWOOD SCHOOLS ACTIVITY FUN	\$0.00	\$0.00	\$0.00	\$0.00	\$0.00
Grand Total:		\$30,728,768.97	\$20,401,078.71	(\$19,786,551.52)	\$0.00	\$31,343,296.16

End of Report

Lincolnwood School District 74

Treasurers Report FUND- All Funds As of 02/29/2024

Fiscal Year: 2023-2024

ASSETS

CASH & INVESTMENTS

Cash in Bank (+)	\$31,011,736.01
Imprest Fund (+)	\$15,169.34
Petty Cash (+)	\$100.00

Sub-total : CASH & INVESTMENTS	\$31,027,005.35
--------------------------------	-----------------

DUE FROM OTHER GOVERNMENTS

Inter-Governmental Loans (+)	(\$467.03)
------------------------------	------------

Sub-total : DUE FROM OTHER GOVERNMENTS	(\$467.03)
--	------------

Total : ASSETS	\$31,026,538.32
----------------	-----------------

LIABILITIES

ACCOUNTS PAYABLE

Accounts Payable (+)	\$61,290.18
----------------------	-------------

Sub-total : ACCOUNTS PAYABLE	\$61,290.18
------------------------------	-------------

OTHER CURRENT LIABILITIES

Other Liabilities (+)	\$36,072.89
-----------------------	-------------

Payroll Liabilities (+)	(\$414,120.91)
-------------------------	----------------

Sub-total : OTHER CURRENT LIABILITIES	(\$378,048.02)
---------------------------------------	----------------

Total : LIABILITIES	(\$316,757.84)
---------------------	----------------

FUND BALANCE

Unreserved Fund Balance

Fund Balance (+)	\$30,728,768.97
------------------	-----------------

Sub-total : Unreserved Fund Balance	\$30,728,768.97
-------------------------------------	-----------------

NET INCREASE (DECREASE)

NET INCREASE (DECREASE) (+)	\$614,527.19
-----------------------------	--------------

Sub-total : NET INCREASE (DECREASE)	\$614,527.19
-------------------------------------	--------------

Total : FUND BALANCE	\$31,343,296.16
----------------------	-----------------

Total LIABILITIES + FUND BALANCE	\$31,026,538.32
----------------------------------	-----------------

End of Report

# Lincolnwood School District 74

## Treasurers Report FUND- All Funds For the Period 02/01/2024 through 02/29/2024

Fiscal Year: 2023-2024

	<u>02/01/2024 - 02/29/2024</u>	<u>Year To Date</u>	<u>Budget</u>	<u>Budget Balance</u>	
<b>REVENUE</b>					
<b>LOCAL SOURCES</b>					
Property Tax Receipts (+)	\$3,437,550.14	\$16,419,473.60	\$27,268,336.00	\$10,848,862.40	60.2%
Payments in Lieu of Taxes (+)	\$0.00	\$856,566.75	\$1,290,000.00	\$433,433.25	66.4%
Tuition Payments Received (+)	\$7,200.00	\$75,940.00	\$240,000.00	\$164,060.00	31.6%
Interest Revenue Received (+)	\$42,229.26	\$328,580.74	\$630,000.00	\$301,419.26	52.2%
Sales to Pupils & Adults (+)	\$23,313.10	\$146,811.54	\$200,000.00	\$53,188.46	73.4%
Activity Fees Received (+)	\$2,248.38	\$59,787.79	\$122,500.00	\$62,712.21	48.8%
Other Local Revenue (+)	\$32,014.03	\$215,356.60	\$295,222.00	\$79,865.40	72.9%
Rental Revenue (+)	\$1,127.12	\$54,299.61	\$98,000.00	\$43,700.39	55.4%
<b>Sub-total : LOCAL SOURCES</b>	<b>\$3,545,682.03</b>	<b>\$18,156,816.63</b>	<b>\$30,144,058.00</b>	<b>\$11,987,241.37</b>	<b>60.2%</b>
<b>STATE SOURCES</b>					
State Grants & Aid Received (+)	\$106,060.00	\$1,112,363.11	\$1,622,000.00	\$509,636.89	68.6%
<b>Sub-total : STATE SOURCES</b>	<b>\$106,060.00</b>	<b>\$1,112,363.11</b>	<b>\$1,622,000.00</b>	<b>\$509,636.89</b>	<b>68.6%</b>
<b>FEDERAL SOURCES</b>					
Federal Grants & Aid Received (+)	\$422,462.47	\$1,131,898.97	\$1,238,804.00	\$106,905.03	91.4%
<b>Sub-total : FEDERAL SOURCES</b>	<b>\$422,462.47</b>	<b>\$1,131,898.97</b>	<b>\$1,238,804.00</b>	<b>\$106,905.03</b>	<b>91.4%</b>
<b>Total : REVENUE</b>	<b>\$4,074,204.50</b>	<b>\$20,401,078.71</b>	<b>\$33,004,862.00</b>	<b>\$12,603,783.29</b>	<b>61.8%</b>
<b>EXPENDITURES</b>					
<b>REGULAR K-12 PROGRAMS</b>					
Salaries (-)	\$613,651.04	\$3,949,861.45	\$8,010,572.00	\$4,060,710.55	49.3%
Employee Benefits (-)	\$109,552.26	\$691,983.23	\$1,372,227.00	\$680,243.77	50.4%
Termination Benefits (-)	\$21,810.59	\$197,288.96	\$403,608.00	\$206,319.04	48.9%
Purchased Services (-)	\$6,335.09	\$86,861.85	\$220,600.00	\$133,738.15	39.4%
Supplies & Materials (-)	\$9,438.49	\$198,220.37	\$660,788.00	\$462,567.63	30.0%
Capital Expenditures (-)	\$0.00	\$142,777.45	\$258,600.00	\$115,822.55	55.2%
Other Objects (-)	\$87.07	\$87.07	\$1,200.00	\$1,112.93	7.3%
Non-Capitalized Equipment (-)	\$469.21	\$4,294.46	\$113,250.00	\$108,955.54	3.8%
<b>Sub-total : REGULAR K-12 PROGRAMS</b>	<b>(\$761,343.75)</b>	<b>(\$5,271,374.84)</b>	<b>(\$11,040,845.00)</b>	<b>(\$5,769,470.16)</b>	<b>47.7%</b>
<b>PRE-K PROGRAMS</b>					
Salaries (-)	\$19,774.48	\$128,534.12	\$278,422.00	\$149,887.88	46.2%
Employee Benefits (-)	\$6,740.43	\$42,884.71	\$72,205.00	\$29,320.29	59.4%
Supplies & Materials (-)	\$32.87	\$985.62	\$4,200.00	\$3,214.38	23.5%
Capital Expenditures (-)	\$0.00	\$1,837.70	\$1,850.00	\$12.30	99.3%
Non-Capitalized Equipment (-)	\$0.00	\$1,307.55	\$500.00	(\$807.55)	261.5%
<b>Sub-total : PRE-K PROGRAMS</b>	<b>(\$26,547.78)</b>	<b>(\$175,549.70)</b>	<b>(\$357,177.00)</b>	<b>(\$181,627.30)</b>	<b>49.1%</b>
<b>SPECIAL ED PROGRAMS K-12</b>					
Salaries (-)	\$107,001.93	\$681,763.98	\$1,350,598.00	\$668,834.02	50.5%
Employee Benefits (-)	\$28,178.88	\$171,852.13	\$363,836.00	\$191,983.87	47.2%
Purchased Services (-)	\$748.60	\$1,521.72	\$800.00	(\$721.72)	190.2%
Supplies & Materials (-)	\$110.02	\$553.00	\$3,500.00	\$2,947.00	15.8%
Capital Expenditures (-)	\$796.31	\$2,641.31	\$5,500.00	\$2,858.69	48.0%
Other Objects (-)	\$0.00	\$250.00	\$200.00	(\$50.00)	125.0%

Operating Statement with Budget

Lincolnwood School District 74

Treasurers Report FUND- All Funds For the Period 02/01/2024 through 02/29/2024

Fiscal Year: 2023-2024

	<u>02/01/2024 - 02/29/2024</u>	<u>Year To Date</u>	<u>Budget</u>	<u>Budget Balance</u>	
Non-Capital Equipment (-)	\$13.28	\$351.63	\$3,500.00	\$3,148.37	10.0%
Sub-total : SPECIAL ED PROGRAMS K-12	(\$136,849.02)	(\$858,933.77)	(\$1,727,934.00)	(\$869,000.23)	49.7%
<b>REMEDIAL &amp; SUPPLEMENTAL K-12</b>					
Salaries (-)	\$47,059.06	\$303,768.48	\$606,768.00	\$302,999.52	50.1%
Employee Benefits (-)	\$9,141.36	\$53,261.59	\$98,830.00	\$45,568.41	53.9%
Purchased Services (-)	\$6,220.00	\$59,710.00	\$53,490.00	(\$6,220.00)	111.6%
Supplies & Materials (-)	\$0.00	\$563.88	\$9,965.00	\$9,401.12	5.7%
Sub-total : REMEDIAL & SUPPLEMENTAL K-12	(\$62,420.42)	(\$417,303.95)	(\$769,053.00)	(\$351,749.05)	54.3%
<b>INTERSCHOLASTIC PROGRAMS</b>					
Salaries (-)	\$1,949.11	\$40,528.93	\$100,000.00	\$59,471.07	40.5%
Employee Benefits (-)	\$122.56	\$1,905.65	\$4,300.00	\$2,394.35	44.3%
Supplies & Materials (-)	\$103.56	\$5,139.82	\$6,500.00	\$1,360.18	79.1%
Capital Expenditures (-)	\$0.00	\$0.00	\$1,500.00	\$1,500.00	0.0%
Other Objects (-)	\$175.00	\$3,675.00	\$3,500.00	(\$175.00)	105.0%
Sub-total : INTERSCHOLASTIC PROGRAMS	(\$2,350.23)	(\$51,249.40)	(\$115,800.00)	(\$64,550.60)	44.3%
<b>SUMMER SCHOOL PROGRAMS</b>					
Salaries (-)	\$0.00	\$37,467.38	\$71,000.00	\$33,532.62	52.8%
Employee Benefits (-)	\$0.00	\$1,654.88	\$3,545.00	\$1,890.12	46.7%
Supplies & Materials (-)	\$0.00	\$0.00	\$2,500.00	\$2,500.00	0.0%
Sub-total : SUMMER SCHOOL PROGRAMS	\$0.00	(\$39,122.26)	(\$77,045.00)	(\$37,922.74)	50.8%
<b>GIFTED PROGRAMS</b>					
Salaries (-)	\$38,652.14	\$251,398.41	\$502,478.00	\$251,079.59	50.0%
Employee Benefits (-)	\$9,153.05	\$49,579.08	\$93,752.00	\$44,172.92	52.9%
Supplies & Materials (-)	\$190.00	\$2,413.32	\$3,950.00	\$1,536.68	61.1%
Sub-total : GIFTED PROGRAMS	(\$47,995.19)	(\$303,390.81)	(\$600,180.00)	(\$296,789.19)	50.5%
<b>BILINGUAL PROGRAMS</b>					
Salaries (-)	\$54,538.62	\$347,124.60	\$689,408.00	\$342,283.40	50.4%
Employee Benefits (-)	\$9,107.51	\$54,375.37	\$110,064.00	\$55,688.63	49.4%
Purchased Services (-)	\$0.00	\$0.00	\$3,200.00	\$3,200.00	0.0%
Supplies & Materials (-)	\$254.42	\$1,030.21	\$10,000.00	\$8,969.79	10.3%
Sub-total : BILINGUAL PROGRAMS	(\$63,900.55)	(\$402,530.18)	(\$812,672.00)	(\$410,141.82)	49.5%
<b>ATTENDANCE &amp; SOCIAL WORK</b>					
Salaries (-)	\$31,857.20	\$207,071.80	\$414,143.00	\$207,071.20	50.0%
Employee Benefits (-)	\$3,870.75	\$23,703.45	\$47,683.00	\$23,979.55	49.7%
Purchased Services (-)	\$0.00	\$0.00	\$300.00	\$300.00	0.0%
Supplies & Materials (-)	\$93.56	\$1,145.04	\$2,000.00	\$854.96	57.3%
Sub-total : ATTENDANCE & SOCIAL WORK	(\$35,821.51)	(\$231,920.29)	(\$464,126.00)	(\$232,205.71)	50.0%
<b>HEALTH SERVICES</b>					
Salaries (-)	\$10,401.00	\$93,087.79	\$173,000.00	\$79,912.21	53.8%
Employee Benefits (-)	\$2,682.22	\$20,516.63	\$60,611.00	\$40,094.37	33.8%

Operating Statement with Budget

Lincolnwood School District 74

Treasurers Report FUND- All Funds For the Period 02/01/2024 through 02/29/2024

Fiscal Year: 2023-2024

	<u>02/01/2024 - 02/29/2024</u>	<u>Year To Date</u>	<u>Budget</u>	<u>Budget Balance</u>	
Purchased Services (-)	\$9,048.75	\$54,542.50	\$80,500.00	\$25,957.50	67.8%
Supplies & Materials (-)	\$793.77	\$3,031.84	\$5,400.00	\$2,368.16	56.1%
Capital Expenditures (-)	\$0.00	\$0.00	\$3,000.00	\$3,000.00	0.0%
Other Objects (-)	\$0.00	\$400.00	\$750.00	\$350.00	53.3%
Non-Capital Equipment (-)	\$74.24	\$74.24	\$1,500.00	\$1,425.76	4.9%
<b>Sub-total : HEALTH SERVICES</b>	<b>(\$22,999.98)</b>	<b>(\$171,653.00)</b>	<b>(\$324,761.00)</b>	<b>(\$153,108.00)</b>	<b>52.9%</b>
<b>PSYCHOLOGICAL SERVICES</b>					
Salaries (-)	\$14,267.54	\$92,739.01	\$185,478.00	\$92,738.99	50.0%
Employee Benefits (-)	\$3,241.74	\$19,663.97	\$39,511.00	\$19,847.03	49.8%
Purchased Services (-)	\$0.00	\$1,035.30	\$2,300.00	\$1,264.70	45.0%
Supplies & Materials (-)	\$0.00	\$33.88	\$1,400.00	\$1,366.12	2.4%
<b>Sub-total : PSYCHOLOGICAL SERVICES</b>	<b>(\$17,509.28)</b>	<b>(\$113,472.16)</b>	<b>(\$228,689.00)</b>	<b>(\$115,216.84)</b>	<b>49.6%</b>
<b>SPEECH PATHOLOGY &amp; AUDIOLOGY</b>					
Salaries (-)	\$19,347.98	\$129,343.92	\$284,658.00	\$155,314.08	45.4%
Employee Benefits (-)	\$3,432.16	\$20,980.13	\$42,774.00	\$21,793.87	49.0%
Purchased Services (-)	\$2,800.00	\$16,333.10	\$2,000.00	(\$14,333.10)	816.7%
Supplies & Materials (-)	\$0.00	\$445.74	\$1,450.00	\$1,004.26	30.7%
<b>Sub-total : SPEECH PATHOLOGY &amp; AUDIOLOGY</b>	<b>(\$25,580.14)</b>	<b>(\$167,102.89)</b>	<b>(\$330,882.00)</b>	<b>(\$163,779.11)</b>	<b>50.5%</b>
<b>OTHER SUPPORT SERVICES - PUPILS</b>					
Salaries (-)	\$10,480.81	\$56,196.31	\$86,000.00	\$29,803.69	65.3%
Employee Benefits (-)	\$665.10	\$3,463.10	\$5,870.00	\$2,406.90	59.0%
<b>Sub-total : OTHER SUPPORT SERVICES - PUPILS</b>	<b>(\$11,145.91)</b>	<b>(\$59,659.41)</b>	<b>(\$91,870.00)</b>	<b>(\$32,210.59)</b>	<b>64.9%</b>
<b>IMPROVEMENT OF INSTRUCTION</b>					
Salaries (-)	\$27,697.20	\$243,869.54	\$377,126.00	\$133,256.46	64.7%
Employee Benefits (-)	\$7,014.24	\$40,008.73	\$62,781.00	\$22,772.27	63.7%
Purchased Services (-)	\$24,210.50	\$48,717.82	\$67,785.00	\$19,067.18	71.9%
Supplies & Materials (-)	\$0.00	\$218.32	\$2,000.00	\$1,781.68	10.9%
Other Objects (-)	\$0.00	\$0.00	\$4,425.00	\$4,425.00	0.0%
<b>Sub-total : IMPROVEMENT OF INSTRUCTION</b>	<b>(\$58,921.94)</b>	<b>(\$332,814.41)</b>	<b>(\$514,117.00)</b>	<b>(\$181,302.59)</b>	<b>64.7%</b>
<b>EDUCATIONAL MEDIA</b>					
Salaries (-)	\$21,820.52	\$141,833.38	\$283,667.00	\$141,833.62	50.0%
Employee Benefits (-)	\$2,698.22	\$16,500.44	\$33,184.00	\$16,683.56	49.7%
Supplies & Materials (-)	\$363.83	\$13,142.20	\$19,000.00	\$5,857.80	69.2%
Non-Capital Equipment (-)	\$0.00	\$0.00	\$500.00	\$500.00	0.0%
<b>Sub-total : EDUCATIONAL MEDIA</b>	<b>(\$24,882.57)</b>	<b>(\$171,476.02)</b>	<b>(\$336,351.00)</b>	<b>(\$164,874.98)</b>	<b>51.0%</b>
<b>ASSESSMENT &amp; TESTING</b>					
Purchased Services (-)	\$0.00	\$45,492.30	\$45,493.00	\$0.70	100.0%
Supplies & Materials (-)	\$0.00	\$0.00	\$100.00	\$100.00	0.0%
<b>Sub-total : ASSESSMENT &amp; TESTING</b>	<b>\$0.00</b>	<b>(\$45,492.30)</b>	<b>(\$45,593.00)</b>	<b>(\$100.70)</b>	<b>99.8%</b>
<b>ADMIN SERVICES - BOARD OF ED</b>					

Operating Statement with Budget

Lincolnwood School District 74

Treasurers Report FUND- All Funds For the Period 02/01/2024 through 02/29/2024

Fiscal Year: 2023-2024

	<u>02/01/2024 - 02/29/2024</u>	<u>Year To Date</u>	<u>Budget</u>	<u>Budget Balance</u>	
Employee Benefits (-)	\$0.00	\$9,571.23	\$3,550.00	(\$6,021.23)	269.6%
Purchased Services (-)	\$16,088.91	\$113,002.00	\$230,000.00	\$116,998.00	49.1%
Supplies & Materials (-)	\$0.00	\$302.47	\$2,500.00	\$2,197.53	12.1%
Other Objects (-)	\$0.00	\$470.00	\$16,000.00	\$15,530.00	2.9%
Sub-total : ADMIN SERVICES - BOARD OF ED	(\$16,088.91)	(\$123,345.70)	(\$252,050.00)	(\$128,704.30)	48.9%
<b>SUPERINTENDENT</b>					
Salaries (-)	\$19,949.28	\$170,557.89	\$270,330.00	\$99,772.11	63.1%
Employee Benefits (-)	\$3,706.09	\$40,310.01	\$57,282.00	\$16,971.99	70.4%
Purchased Services (-)	\$0.00	\$2,798.01	\$7,500.00	\$4,701.99	37.3%
Supplies & Materials (-)	\$0.00	\$546.46	\$2,300.00	\$1,753.54	23.8%
Other Objects (-)	\$200.00	\$447.97	\$3,500.00	\$3,052.03	12.8%
Sub-total : SUPERINTENDENT	(\$23,855.37)	(\$214,660.34)	(\$340,912.00)	(\$126,251.66)	63.0%
<b>ADMIN SERVICES - SPECIAL ED</b>					
Salaries (-)	\$11,761.98	\$99,976.83	\$153,103.00	\$53,126.17	65.3%
Employee Benefits (-)	\$3,778.69	\$30,516.94	\$46,285.00	\$15,768.06	65.9%
Other Objects (-)	\$0.00	\$0.00	\$750.00	\$750.00	0.0%
Sub-total : ADMIN SERVICES - SPECIAL ED	(\$15,540.67)	(\$130,493.77)	(\$200,138.00)	(\$69,644.23)	65.2%
<b>WORKERS COMPENSATION INSURANCE</b>					
Purchased Services (-)	\$0.00	\$8,655.00	\$75,800.00	\$67,145.00	11.4%
Sub-total : WORKERS COMPENSATION INSURANCE	\$0.00	(\$8,655.00)	(\$75,800.00)	(\$67,145.00)	11.4%
<b>PROPERTY INSURANCE</b>					
Purchased Services (-)	\$0.00	\$0.00	\$120,000.00	\$120,000.00	0.0%
Sub-total : PROPERTY INSURANCE	\$0.00	\$0.00	(\$120,000.00)	(\$120,000.00)	0.0%
<b>PRINCIPAL</b>					
Salaries (-)	\$54,551.77	\$464,391.59	\$710,378.00	\$245,986.41	65.4%
Employee Benefits (-)	\$17,524.68	\$145,000.19	\$235,906.00	\$90,905.81	61.5%
Purchased Services (-)	\$409.33	\$3,037.83	\$5,050.00	\$2,012.17	60.2%
Supplies & Materials (-)	\$134.08	\$1,052.09	\$4,000.00	\$2,947.91	26.3%
Capital Expenditures (-)	\$0.00	\$0.00	\$1,000.00	\$1,000.00	0.0%
Other Objects (-)	\$429.00	\$1,625.99	\$2,400.00	\$774.01	67.7%
Sub-total : PRINCIPAL	(\$73,048.86)	(\$615,107.69)	(\$958,734.00)	(\$343,626.31)	64.2%
<b>OPERATION OF BUSINESS SERVICES</b>					
Salaries (-)	\$15,215.56	\$129,332.26	\$197,803.00	\$68,470.74	65.4%
Employee Benefits (-)	\$2,757.57	\$22,358.68	\$33,823.00	\$11,464.32	66.1%
Other Objects (-)	\$0.00	\$1,453.79	\$1,300.00	(\$153.79)	111.8%
Sub-total : OPERATION OF BUSINESS SERVICES	(\$17,973.13)	(\$153,144.73)	(\$232,926.00)	(\$79,781.27)	65.7%
<b>FISCAL SERVICES</b>					
Salaries (-)	\$18,713.88	\$159,131.33	\$243,583.00	\$84,451.67	65.3%
Employee Benefits (-)	\$8,210.62	\$66,761.80	\$101,468.00	\$34,706.20	65.8%
Purchased Services (-)	\$230.75	\$2,055.14	\$108,600.00	\$106,544.86	1.9%

Operating Statement with Budget

Lincolnwood School District 74

Treasurers Report FUND- All Funds For the Period 02/01/2024 through 02/29/2024

Fiscal Year: 2023-2024

	<u>02/01/2024 - 02/29/2024</u>	<u>Year To Date</u>	<u>Budget</u>	<u>Budget Balance</u>	
Supplies & Materials (-)	\$473.74	\$2,850.35	\$5,500.00	\$2,649.65	51.8%
Other Objects (-)	\$1,068.83	\$13,740.16	\$29,900.00	\$16,159.84	46.0%
Sub-total : FISCAL SERVICES	(\$28,697.82)	(\$244,538.78)	(\$489,051.00)	(\$244,512.22)	50.0%
<b>FACILITY ACQUISITION &amp; CONSTRUCTION</b>					
Purchased Services (-)	\$0.00	\$309,558.31	\$315,504.00	\$5,945.69	98.1%
Capital Expenditures (-)	\$29,088.90	\$1,422,945.46	\$1,689,139.00	\$266,193.54	84.2%
Sub-total : FACILITY ACQUISITION & CONSTRUCTION	(\$29,088.90)	(\$1,732,503.77)	(\$2,004,643.00)	(\$272,139.23)	86.4%
<b>OPERATION &amp; MAINTENANCE OF PLANT</b>					
Salaries (-)	\$52,855.36	\$364,488.27	\$542,404.00	\$177,915.73	67.2%
Employee Benefits (-)	\$14,696.90	\$109,848.14	\$175,110.00	\$65,261.86	62.7%
Purchased Services (-)	\$59,904.64	\$812,527.45	\$1,011,473.00	\$198,945.55	80.3%
Supplies & Materials (-)	\$51,712.04	\$392,518.08	\$408,966.00	\$16,447.92	96.0%
Capital Expenditures (-)	\$0.00	\$1,337,970.33	\$1,588,362.00	\$250,391.67	84.2%
Other Objects (-)	\$657.00	\$657.00	\$1,000.00	\$343.00	65.7%
Non-Capitalized Equipment (-)	\$0.00	\$221.95	\$6,500.00	\$6,278.05	3.4%
Sub-total : OPERATION & MAINTENANCE OF PLANT	(\$179,825.94)	(\$3,018,231.22)	(\$3,733,815.00)	(\$715,583.78)	80.8%
<b>PUPIL TRANSPORTATION</b>					
Purchased Services (-)	\$176,754.34	\$915,579.66	\$1,451,000.00	\$535,420.34	63.1%
Sub-total : PUPIL TRANSPORTATION	(\$176,754.34)	(\$915,579.66)	(\$1,451,000.00)	(\$535,420.34)	63.1%
<b>FOOD SERVICES</b>					
Salaries (-)	\$24,405.85	\$156,054.83	\$259,800.00	\$103,745.17	60.1%
Employee Benefits (-)	\$9,524.94	\$66,988.70	\$134,163.00	\$67,174.30	49.9%
Purchased Services (-)	\$0.00	\$29.58	\$17,000.00	\$16,970.42	0.2%
Supplies & Materials (-)	\$37,175.79	\$190,936.65	\$262,500.00	\$71,563.35	72.7%
Capital Expenditures (-)	\$0.00	\$0.00	\$8,000.00	\$8,000.00	0.0%
Other Objects (-)	\$99.00	\$798.00	\$800.00	\$2.00	99.8%
Non-Capitalized Equipment (-)	\$1,042.61	\$1,977.53	\$4,000.00	\$2,022.47	49.4%
Termination Benefits (-)	\$0.00	\$37,276.18	\$32,000.00	(\$5,276.18)	116.5%
Sub-total : FOOD SERVICES	(\$72,248.19)	(\$454,061.47)	(\$718,263.00)	(\$264,201.53)	63.2%
<b>INTERNAL SERVICES</b>					
Purchased Services (-)	\$3,275.65	\$14,794.26	\$24,500.00	\$9,705.74	60.4%
Supplies & Materials (-)	\$499.99	\$999.89	\$1,500.00	\$500.11	66.7%
Sub-total : INTERNAL SERVICES	(\$3,775.64)	(\$15,794.15)	(\$26,000.00)	(\$10,205.85)	60.7%
<b>INFORMATION SERVICES</b>					
Salaries (-)	\$6,041.08	\$51,349.18	\$78,534.00	\$27,184.82	65.4%
Employee Benefits (-)	\$3,819.12	\$30,890.77	\$47,297.00	\$16,406.23	65.3%
Purchased Services (-)	\$0.00	\$8,364.00	\$30,500.00	\$22,136.00	27.4%
Supplies & Materials (-)	\$41.98	\$9,941.67	\$8,000.00	(\$1,941.67)	124.3%
Capital Expenditures (-)	\$0.00	\$513.54	\$0.00	(\$513.54)	0.0%
Other Objects (-)	\$250.00	\$670.00	\$500.00	(\$170.00)	134.0%

Operating Statement with Budget

Lincolnwood School District 74

Treasurers Report FUND- All Funds For the Period 02/01/2024 through 02/29/2024

Fiscal Year: 2023-2024

	<u>02/01/2024 - 02/29/2024</u>	<u>Year To Date</u>	<u>Budget</u>	<u>Budget Balance</u>	
Sub-total : INFORMATION SERVICES	(\$10,152.18)	(\$101,729.16)	(\$164,831.00)	(\$63,101.84)	61.7%
OTHER SUPPORT SERVICES - ADMIN					
Salaries (-)	\$43,768.46	\$360,562.95	\$554,265.00	\$193,702.05	65.1%
Employee Benefits (-)	\$14,054.64	\$110,182.37	\$170,323.00	\$60,140.63	64.7%
Purchased Services (-)	\$0.00	\$0.00	\$500.00	\$500.00	0.0%
Supplies & Materials (-)	\$0.00	\$0.00	\$200.00	\$200.00	0.0%
Other Objects (-)	\$0.00	\$0.00	\$500.00	\$500.00	0.0%
Sub-total : OTHER SUPPORT SERVICES - ADMIN	(\$57,823.10)	(\$470,745.32)	(\$725,788.00)	(\$255,042.68)	64.9%
COMMUNITY SERVICES					
Purchased Services (-)	\$0.00	\$0.00	\$1,000.00	\$1,000.00	0.0%
Supplies & Materials (-)	\$0.00	\$0.00	\$830.00	\$830.00	0.0%
Sub-total : COMMUNITY SERVICES	\$0.00	\$0.00	(\$1,830.00)	(\$1,830.00)	0.0%
PAYMENTS TO OTHER LEAs					
Purchased Services (-)	\$0.00	\$72,607.06	\$164,676.00	\$92,068.94	44.1%
Other Objects (-)	\$38,871.39	\$1,186,933.31	\$2,557,723.00	\$1,370,789.69	46.4%
Sub-total : PAYMENTS TO OTHER LEAs	(\$38,871.39)	(\$1,259,540.37)	(\$2,722,399.00)	(\$1,462,858.63)	46.3%
DEBT SERVICE - INTEREST					
Interest on Bonds Outstanding (-)	\$0.00	\$310,375.00	\$600,725.00	\$290,350.00	51.7%
Sub-total : DEBT SERVICE - INTEREST	\$0.00	(\$310,375.00)	(\$600,725.00)	(\$290,350.00)	51.7%
DEBT SERVICE - PRINCIPAL					
Principal Payments on Bonds Outstanding (-)	\$0.00	\$1,205,000.00	\$1,205,000.00	\$0.00	100.0%
Sub-total : DEBT SERVICE - PRINCIPAL	\$0.00	(\$1,205,000.00)	(\$1,205,000.00)	\$0.00	100.0%
Total : EXPENDITURES	(\$2,042,012.71)	(\$19,786,551.52)	(\$33,861,000.00)	(\$14,074,448.48)	58.4%
OTHER FINANCING SOURCES & USES					
TRANSFERS FROM OTHER FUNDS					
Transfers Received (+)	\$0.00	\$2,000,000.00	\$0.00	(\$2,000,000.00)	0.0%
Sub-total : TRANSFERS FROM OTHER FUNDS	\$0.00	\$2,000,000.00	\$0.00	(\$2,000,000.00)	0.0%
TRANSFERS TO OTHER FUNDS					
Transfers Sent (-)	\$0.00	\$2,000,000.00	\$0.00	(\$2,000,000.00)	0.0%
Sub-total : TRANSFERS TO OTHER FUNDS	\$0.00	(\$2,000,000.00)	\$0.00	\$2,000,000.00	0.0%
Total : OTHER FINANCING SOURCES & USES	\$0.00	\$0.00	\$0.00	\$0.00	0.0%
NET INCREASE (DECREASE)	\$2,032,191.79	\$614,527.19	(\$856,138.00)	(\$1,470,665.19)	71.8%

End of Report

**Lincolnwood School District 74**

**General Ledger - OBJECT REPORT**

Fiscal Year: 2023-2024 From Date:2/1/2024 To Date:2/29/2024

Account Mask: ??????????????????

Account Type: EXPENDITURE

Print accounts with zero balance       Include Inactive Accounts       Include PreEncumbrance

FUND / TYPE / FUNCTION / OBJECT	Preliminary 2024	Range To Date	Year To Date	Encumbrance	Budget Balance
<b>10 - EDUCATIONAL</b>					
0 - EXPENDITURES					
1100 - REGULAR K-12 PROGRAMS					
100 - SALARIES	\$8,010,572.00	\$613,651.04	\$3,949,861.45	\$3,863,874.41	\$196,836.14
200 - EMPLOYEE BENEFITS	\$1,245,577.00	\$99,931.85	\$629,925.51	\$598,504.57	\$17,146.92
300 - PURCHASED SERVICES	\$220,600.00	\$6,335.09	\$86,861.85	\$0.00	\$133,738.15
400 - SUPPLIES & MATERIALS	\$660,788.00	\$9,438.49	\$198,220.37	\$114,953.95	\$347,613.68
500 - CAPITAL OUTLAY	\$258,600.00	\$0.00	\$142,777.45	\$0.00	\$115,822.55
600 - OTHER OBJECTS	\$1,200.00	\$87.07	\$87.07	\$0.00	\$1,112.93
700 - NON-CAPITAL EQUIPMENT	\$113,250.00	\$469.21	\$4,294.46	\$0.00	\$108,955.54
800 - TERMINATION/VACATION PAYMENTS	\$403,608.00	\$21,810.59	\$197,288.96	\$61,724.60	\$144,594.44
1125 - PRE-K PROGRAMS					
100 - SALARIES	\$278,422.00	\$19,774.48	\$128,534.12	\$115,711.04	\$34,176.84
200 - EMPLOYEE BENEFITS	\$60,905.00	\$5,907.79	\$37,556.13	\$27,572.51	(\$4,223.64)
400 - SUPPLIES & MATERIALS	\$4,200.00	\$32.87	\$985.62	\$360.60	\$2,853.78
500 - CAPITAL OUTLAY	\$1,850.00	\$0.00	\$1,837.70	\$0.00	\$12.30
700 - NON-CAPITAL EQUIPMENT	\$500.00	\$0.00	\$1,307.55	\$0.00	(\$807.55)
1200 - SPECIAL ED PROGRAMS K-12					
100 - SALARIES	\$1,350,598.00	\$107,001.93	\$681,763.98	\$600,519.51	\$68,314.51
200 - EMPLOYEE BENEFITS	\$298,046.00	\$21,395.10	\$131,176.99	\$106,685.11	\$60,183.90
300 - PURCHASED SERVICES	\$800.00	\$748.60	\$1,521.72	\$0.00	(\$721.72)
400 - SUPPLIES & MATERIALS	\$3,500.00	\$110.02	\$553.00	\$253.67	\$2,693.33
500 - CAPITAL OUTLAY	\$5,500.00	\$796.31	\$2,641.31	\$0.00	\$2,858.69
600 - OTHER OBJECTS	\$200.00	\$0.00	\$250.00	\$0.00	(\$50.00)
700 - NON-CAPITAL EQUIPMENT	\$3,500.00	\$13.28	\$351.63	\$440.00	\$2,708.37
1250 - REMEDIAL & SUPPLEMENTAL K-12					
100 - SALARIES	\$606,768.00	\$47,059.06	\$303,768.48	\$305,884.14	(\$2,884.62)
200 - EMPLOYEE BENEFITS	\$90,559.00	\$8,506.27	\$49,108.30	\$51,612.49	(\$10,161.79)
300 - PURCHASED SERVICES	\$53,490.00	\$6,220.00	\$59,710.00	\$12,440.00	(\$18,660.00)
400 - SUPPLIES & MATERIALS	\$9,965.00	\$0.00	\$563.88	\$0.00	\$9,401.12
1500 - INTERSCHOLASTIC PROGRAMS					
100 - SALARIES	\$100,000.00	\$1,949.11	\$40,528.93	\$40,124.08	\$19,346.99
200 - EMPLOYEE BENEFITS	\$1,100.00	\$17.20	\$408.97	\$395.08	\$295.95
400 - SUPPLIES & MATERIALS	\$6,500.0013	\$103.56	\$5,139.82	\$1,840.24	(\$480.06)

# Lincolnwood School District 74

## General Ledger - OBJECT REPORT

Fiscal Year: 2023-2024    From Date: 2/1/2024    To Date: 2/29/2024

Account Mask: ????????????????????

Account Type: EXPENDITURE

Print accounts with zero balance   
  Include Inactive Accounts   
  Include PreEncumbrance

FUND / TYPE / FUNCTION / OBJECT	Preliminary 2024	Range To Date	Year To Date	Encumbrance	Budget Balance
500 - CAPITAL OUTLAY	\$1,500.00	\$0.00	\$0.00	\$0.00	\$1,500.00
600 - OTHER OBJECTS	\$3,500.00	\$175.00	\$3,675.00	\$0.00	(\$175.00)
1600 - SUMMER SCHOOL PROGRAMS					
100 - SALARIES	\$71,000.00	\$0.00	\$37,467.38	\$0.00	\$33,532.62
200 - EMPLOYEE BENEFITS	\$1,145.00	\$0.00	\$496.32	\$0.00	\$648.68
400 - SUPPLIES & MATERIALS	\$2,500.00	\$0.00	\$0.00	\$0.00	\$2,500.00
1650 - GIFTED PROGRAMS					
100 - SALARIES	\$502,478.00	\$38,652.14	\$251,398.41	\$251,239.09	(\$159.50)
200 - EMPLOYEE BENEFITS	\$86,949.00	\$8,640.96	\$46,191.17	\$52,144.77	(\$11,386.94)
400 - SUPPLIES & MATERIALS	\$3,950.00	\$190.00	\$2,413.32	\$380.69	\$1,155.99
1800 - BILINGUAL PROGRAMS					
100 - SALARIES	\$689,408.00	\$54,538.62	\$347,124.60	\$346,098.21	(\$3,814.81)
200 - EMPLOYEE BENEFITS	\$100,030.00	\$8,325.78	\$49,525.41	\$49,677.55	\$827.04
300 - PURCHASED SERVICES	\$3,200.00	\$0.00	\$0.00	\$0.00	\$3,200.00
400 - SUPPLIES & MATERIALS	\$10,000.00	\$254.42	\$1,030.21	\$0.00	\$8,969.79
2110 - ATTENDANCE & SOCIAL WORK					
100 - SALARIES	\$414,143.00	\$31,857.20	\$207,071.80	\$207,071.20	\$0.00
200 - EMPLOYEE BENEFITS	\$41,899.00	\$3,427.73	\$20,812.86	\$20,812.86	\$273.28
300 - PURCHASED SERVICES	\$300.00	\$0.00	\$0.00	\$247.50	\$52.50
400 - SUPPLIES & MATERIALS	\$2,000.00	\$93.56	\$1,145.04	\$0.00	\$854.96
2130 - HEALTH SERVICES					
100 - SALARIES	\$173,000.00	\$10,401.00	\$93,087.79	\$48,864.92	\$31,047.29
200 - EMPLOYEE BENEFITS	\$36,101.00	\$1,097.97	\$6,639.70	\$6,131.37	\$23,329.93
300 - PURCHASED SERVICES	\$80,500.00	\$9,048.75	\$54,542.50	\$0.00	\$25,957.50
400 - SUPPLIES & MATERIALS	\$5,400.00	\$793.77	\$3,031.84	\$7,622.18	(\$5,254.02)
500 - CAPITAL OUTLAY	\$3,000.00	\$0.00	\$0.00	\$0.00	\$3,000.00
600 - OTHER OBJECTS	\$750.00	\$0.00	\$400.00	\$0.00	\$350.00
700 - NON-CAPITAL EQUIPMENT	\$1,500.00	\$74.24	\$74.24	\$0.00	\$1,425.76
2140 - PSYCHOLOGICAL SERVICES					
100 - SALARIES	\$185,478.00	\$14,267.54	\$92,739.01	\$92,738.99	\$0.00
200 - EMPLOYEE BENEFITS	\$37,026.00	\$3,051.54	\$18,419.27	\$18,419.27	\$187.46
300 - PURCHASED SERVICES	\$2,300.00	\$0.00	\$1,035.30	\$76.70	\$1,188.00
400 - SUPPLIES & MATERIALS	\$1,400.00	\$0.00	\$33.88	\$0.00	\$1,366.12
2150 - SPEECH PATHOLOGY & AUDIOLOGY					
100 - SALARIES	\$284,658.00 <sup>14</sup>	\$19,347.98	\$129,343.92	\$125,762.13	\$29,551.95

# Lincolnwood School District 74

## General Ledger - OBJECT REPORT

Fiscal Year: 2023-2024 From Date:2/1/2024 To Date:2/29/2024

Account Mask: ??????????????????

Account Type: EXPENDITURE

Print accounts with zero balance     
  Include Inactive Accounts     
  Include PreEncumbrance

FUND / TYPE / FUNCTION / OBJECT	Preliminary 2024	Range To Date	Year To Date	Encumbrance	Budget Balance
200 - EMPLOYEE BENEFITS	\$38,931.00	\$3,175.44	\$19,247.35	\$19,202.58	\$481.07
300 - PURCHASED SERVICES	\$2,000.00	\$2,800.00	\$16,333.10	\$0.00	(\$14,333.10)
400 - SUPPLIES & MATERIALS	\$1,450.00	\$0.00	\$445.74	\$61.18	\$943.08
2190 - OTHER SUPPORT SERVICES - PUPILS					
100 - SALARIES	\$86,000.00	\$10,480.81	\$56,196.31	\$22,518.41	\$7,285.28
200 - EMPLOYEE BENEFITS	\$450.00	\$50.11	\$265.56	\$141.84	\$42.60
2210 - IMPROVEMENT OF INSTRUCTION					
100 - SALARIES	\$377,126.00	\$27,697.20	\$243,869.54	\$120,892.22	\$12,364.24
200 - EMPLOYEE BENEFITS	\$48,534.00	\$5,917.90	\$30,654.69	\$14,521.09	\$3,358.22
300 - PURCHASED SERVICES	\$67,785.00	\$24,210.50	\$48,717.82	\$0.00	\$19,067.18
400 - SUPPLIES & MATERIALS	\$2,000.00	\$0.00	\$218.32	\$12,861.20	(\$11,079.52)
600 - OTHER OBJECTS	\$4,425.00	\$0.00	\$0.00	\$0.00	\$4,425.00
2220 - EDUCATIONAL MEDIA					
100 - SALARIES	\$283,667.00	\$21,820.52	\$141,833.38	\$141,116.57	\$717.05
200 - EMPLOYEE BENEFITS	\$29,216.00	\$2,393.36	\$14,529.25	\$14,518.16	\$168.59
400 - SUPPLIES & MATERIALS	\$19,000.00	\$363.83	\$13,142.20	\$5,759.92	\$97.88
700 - NON-CAPITAL EQUIPMENT	\$500.00	\$0.00	\$0.00	\$0.00	\$500.00
2230 - ASSESSMENT & TESTING					
300 - PURCHASED SERVICES	\$45,493.00	\$0.00	\$45,492.30	\$0.00	\$0.70
400 - SUPPLIES & MATERIALS	\$100.00	\$0.00	\$0.00	\$0.00	\$100.00
2310 - BOARD OF EDUCATION					
200 - EMPLOYEE BENEFITS	\$3,550.00	\$0.00	\$9,571.23	\$0.00	(\$6,021.23)
300 - PURCHASED SERVICES	\$230,000.00	\$16,088.91	\$113,002.00	\$0.00	\$116,998.00
400 - SUPPLIES & MATERIALS	\$2,500.00	\$0.00	\$302.47	\$0.00	\$2,197.53
600 - OTHER OBJECTS	\$16,000.00	\$0.00	\$470.00	\$0.00	\$15,530.00
2320 - SUPERINTENDENT					
100 - SALARIES	\$270,330.00	\$19,949.28	\$170,557.89	\$89,771.76	\$10,000.35
200 - EMPLOYEE BENEFITS	\$53,282.00	\$3,417.83	\$37,844.96	\$13,913.01	\$1,524.03
300 - PURCHASED SERVICES	\$7,500.00	\$0.00	\$2,798.01	\$0.00	\$4,701.99
400 - SUPPLIES & MATERIALS	\$2,300.00	\$0.00	\$546.46	\$0.00	\$1,753.54
600 - OTHER OBJECTS	\$3,500.00	\$200.00	\$447.97	\$0.00	\$3,052.03
2330 - ADMINISTRATIVE SERVICES SPECIAL ED					
100 - SALARIES	\$153,103.00	\$11,761.98	\$99,976.83	\$52,928.81	\$197.36
200 - EMPLOYEE BENEFITS	\$41,382.00	\$3,404.05	\$27,358.62	\$13,742.41	\$280.97
600 - OTHER OBJECTS	\$750.00 <sup>15</sup>	\$0.00	\$0.00	\$0.00	\$750.00

# Lincolnwood School District 74

## General Ledger - OBJECT REPORT

Fiscal Year: 2023-2024    From Date: 2/1/2024    To Date: 2/29/2024

Account Mask: ????????????????????

Account Type: EXPENDITURE

Print accounts with zero balance   
  Include Inactive Accounts   
  Include PreEncumbrance

FUND / TYPE / FUNCTION / OBJECT	Preliminary 2024	Range To Date	Year To Date	Encumbrance	Budget Balance
<b>2410 - PRINCIPAL</b>					
100 - SALARIES	\$710,378.00	\$54,551.77	\$464,391.59	\$236,827.49	\$9,158.92
200 - EMPLOYEE BENEFITS	\$202,588.00	\$14,920.07	\$123,198.11	\$55,457.62	\$23,932.27
300 - PURCHASED SERVICES	\$5,050.00	\$409.33	\$3,037.83	\$0.00	\$2,012.17
400 - SUPPLIES & MATERIALS	\$4,000.00	\$134.08	\$1,052.09	\$0.00	\$2,947.91
500 - CAPITAL OUTLAY	\$1,000.00	\$0.00	\$0.00	\$0.00	\$1,000.00
600 - OTHER OBJECTS	\$2,400.00	\$429.00	\$1,625.99	\$0.00	\$774.01
<b>2510 - DIRECTION OF BUSINESS SUPPORT SERVICES</b>					
100 - SALARIES	\$197,803.00	\$15,215.56	\$129,332.26	\$68,469.92	\$0.82
200 - EMPLOYEE BENEFITS	\$30,973.00	\$2,539.15	\$20,497.53	\$10,340.93	\$134.54
600 - OTHER OBJECTS	\$1,300.00	\$0.00	\$1,453.79	\$0.00	(\$153.79)
<b>2520 - FISCAL SERVICES</b>					
100 - SALARIES	\$243,583.00	\$18,713.88	\$159,131.33	\$84,212.52	\$239.15
200 - EMPLOYEE BENEFITS	\$66,309.00	\$5,509.00	\$44,071.57	\$22,064.07	\$173.36
300 - PURCHASED SERVICES	\$108,600.00	\$230.75	\$2,055.14	\$0.00	\$106,544.86
400 - SUPPLIES & MATERIALS	\$5,500.00	\$473.74	\$2,850.35	\$0.00	\$2,649.65
600 - OTHER OBJECTS	\$29,900.00	\$1,068.83	\$13,740.16	\$0.00	\$16,159.84
<b>2560 - FOOD SERVICES</b>					
100 - SALARIES	\$259,800.00	\$24,405.85	\$156,054.83	\$88,168.89	\$15,576.28
200 - EMPLOYEE BENEFITS	\$93,105.00	\$5,993.46	\$41,552.19	\$23,981.92	\$27,570.89
300 - PURCHASED SERVICES	\$17,000.00	\$0.00	\$29.58	\$0.00	\$16,970.42
400 - SUPPLIES & MATERIALS	\$262,500.00	\$37,175.79	\$190,936.65	\$0.00	\$71,563.35
500 - CAPITAL OUTLAY	\$8,000.00	\$0.00	\$0.00	\$0.00	\$8,000.00
600 - OTHER OBJECTS	\$800.00	\$99.00	\$798.00	\$0.00	\$2.00
700 - NON-CAPITAL EQUIPMENT	\$4,000.00	\$1,042.61	\$1,977.53	\$0.00	\$2,022.47
800 - TERMINATION/VACATION PAYMENTS	\$32,000.00	\$0.00	\$37,276.18	\$0.00	(\$5,276.18)
<b>2570 - INTERNAL SERVICES</b>					
300 - PURCHASED SERVICES	\$24,500.00	\$3,275.65	\$14,794.26	\$0.00	\$9,705.74
400 - SUPPLIES & MATERIALS	\$1,500.00	\$499.99	\$999.89	\$0.00	\$500.11
<b>2630 - INFORMATION SERVICES</b>					
100 - SALARIES	\$78,534.00	\$6,041.08	\$51,349.18	\$27,184.82	\$0.00
200 - EMPLOYEE BENEFITS	\$34,788.00	\$2,877.92	\$23,032.01	\$11,520.33	\$235.66
300 - PURCHASED SERVICES	\$30,500.00	\$0.00	\$8,364.00	\$0.00	\$22,136.00
400 - SUPPLIES & MATERIALS	\$8,000.00	\$41.98	\$9,941.67	\$0.00	(\$1,941.67)
500 - CAPITAL OUTLAY	\$0.00 <sup>16</sup>	\$0.00	\$513.54	\$0.00	(\$513.54)

**Lincolnwood School District 74**

**General Ledger - OBJECT REPORT**

Fiscal Year: 2023-2024 From Date:2/1/2024 To Date:2/29/2024

Account Mask: ??????????????????

Account Type: EXPENDITURE

Print accounts with zero balance     
  Include Inactive Accounts     
  Include PreEncumbrance

FUND / TYPE / FUNCTION / OBJECT	Preliminary 2024	Range To Date	Year To Date	Encumbrance	Budget Balance
600 - OTHER OBJECTS	\$500.00	\$250.00	\$670.00	\$0.00	(\$170.00)
2660 - OTHER SUPPORT SERVICES - PUPILS					
100 - SALARIES	\$554,265.00	\$43,768.46	\$360,562.95	\$193,642.84	\$59.21
200 - EMPLOYEE BENEFITS	\$109,878.00	\$9,326.00	\$72,174.71	\$34,521.84	\$3,181.45
300 - PURCHASED SERVICES	\$500.00	\$0.00	\$0.00	\$0.00	\$500.00
400 - SUPPLIES & MATERIALS	\$200.00	\$0.00	\$0.00	\$0.00	\$200.00
600 - OTHER OBJECTS	\$500.00	\$0.00	\$0.00	\$0.00	\$500.00
3000 - COMMUNITY SERVICES					
300 - PURCHASED SERVICES	\$1,000.00	\$0.00	\$0.00	\$0.00	\$1,000.00
400 - SUPPLIES & MATERIALS	\$830.00	\$0.00	\$0.00	\$0.00	\$830.00
4120 - PAYMENTS FOR SPECIAL ED PROGRAMS					
300 - PURCHASED SERVICES	\$164,676.00	\$0.00	\$72,607.06	\$0.00	\$92,068.94
600 - OTHER OBJECTS	\$2,557,723.00	\$38,871.39	\$1,186,933.31	\$0.00	\$1,370,789.69
<b>10 - EDUCATIONAL Total:</b>	<b>\$24,181,070.00</b>	<b>\$1,617,193.18</b>	<b>\$12,315,551.50</b>	<b>\$8,508,525.78</b>	<b>\$3,356,992.72</b>

**Lincolnwood School District 74**

**General Ledger - OBJECT REPORT**

Fiscal Year: 2023-2024 From Date:2/1/2024 To Date:2/29/2024

Account Mask: ??????????????????

Account Type: EXPENDITURE

Print accounts with zero balance     
  Include Inactive Accounts     
  Include PreEncumbrance

FUND / TYPE / FUNCTION / OBJECT	Preliminary 2024	Range To Date	Year To Date	Encumbrance	Budget Balance
20 - OPERATIONS & MAINTENANCE					
0 - EXPENDITURES					
2540 - OPERATIONS & MAINTENANCE OF PLANTS					
100 - SALARIES	\$542,404.00	\$52,855.36	\$364,488.27	\$195,561.45	(\$17,645.72)
200 - EMPLOYEE BENEFITS	\$92,037.00	\$6,968.31	\$55,801.37	\$27,928.13	\$8,307.50
300 - PURCHASED SERVICES	\$1,011,473.00	\$59,904.64	\$812,527.45	\$0.00	\$198,945.55
400 - SUPPLIES & MATERIALS	\$408,966.00	\$51,712.04	\$392,518.08	\$7,847.38	\$8,600.54
500 - CAPITAL OUTLAY	\$153,000.00	\$0.00	\$72,110.54	\$7,818.18	\$73,071.28
600 - OTHER OBJECTS	\$1,000.00	\$657.00	\$657.00	\$0.00	\$343.00
700 - NON-CAPITAL EQUIPMENT	\$6,500.00	\$0.00	\$221.95	\$0.00	\$6,278.05
20 - OPERATIONS & MAINTENANCE Total:	\$2,215,380.00	\$172,097.35	\$1,698,324.66	\$239,155.14	\$277,900.20

Lincolnwood School District 74

General Ledger - OBJECT REPORT

Fiscal Year: 2023-2024 From Date:2/1/2024 To Date:2/29/2024

Account Mask: ????????????????????

Account Type: EXPENDITURE

Print accounts with zero balance  Include Inactive Accounts  Include PreEncumbrance

FUND / TYPE / FUNCTION / OBJECT

Preliminary 2024 Range To Date Year To Date Encumbrance Budget Balance

30 - DEBT SERVICE

0 - EXPENDITURES

5140 - DEBT SERVICE - INTEREST PAYMENTS

600 - OTHER OBJECTS

\$600,725.00 \$0.00 \$310,375.00 \$0.00 \$290,350.00

5200 - INTEREST ON BONDS OUTSTANDING

600 - OTHER OBJECTS

\$1,205,000.00 \$0.00 \$1,205,000.00 \$0.00 \$0.00

30 - DEBT SERVICE Total: \$1,805,725.00 \$0.00 \$1,515,375.00 \$0.00 \$290,350.00

**Lincolnwood School District 74**

**General Ledger - OBJECT REPORT**

Fiscal Year: 2023-2024 From Date:2/1/2024 To Date:2/29/2024

Account Mask: ????????????????????

Account Type: EXPENDITURE

Print accounts with zero balance       Include Inactive Accounts       Include PreEncumbrance

FUND / TYPE / FUNCTION / OBJECT

Preliminary 2024      Range To Date      Year To Date      Encumbrance      Budget Balance

40 - TRANSPORTATION

    0 - EXPENDITURES

        2550 - PUPIL TRANSPORTATION

            300 - PURCHASED SERVICES

	\$1,451,000.00	\$176,754.34	\$915,579.66	\$0.00	\$535,420.34
--	----------------	--------------	--------------	--------	--------------

40 - TRANSPORTATION Total:	\$1,451,000.00	\$176,754.34	\$915,579.66	\$0.00	\$535,420.34
----------------------------	----------------	--------------	--------------	--------	--------------

# Lincolnwood School District 74

## General Ledger - OBJECT REPORT

Fiscal Year: 2023-2024 From Date: 2/1/2024 To Date: 2/29/2024

Account Mask: ??????????????????

Account Type: EXPENDITURE

Print accounts with zero balance     
  Include Inactive Accounts     
  Include PreEncumbrance

FUND / TYPE / FUNCTION / OBJECT	Preliminary 2024	Range To Date	Year To Date	Encumbrance	Budget Balance
51 - IMRF					
0 - EXPENDITURES					
1100 - REGULAR K-12 PROGRAMS					
200 - EMPLOYEE BENEFITS	\$2,710.00	\$180.15	\$925.32	\$428.71	\$1,355.97
1125 - PRE-K PROGRAMS					
200 - EMPLOYEE BENEFITS	\$5,000.00	\$402.26	\$2,532.53	\$1,597.85	\$869.62
1200 - SPECIAL ED PROGRAMS K-12					
200 - EMPLOYEE BENEFITS	\$27,690.00	\$3,162.23	\$18,404.13	\$13,021.34	(\$3,735.47)
1500 - INTERSCHOLASTIC PROGRAMS					
200 - EMPLOYEE BENEFITS	\$700.00	\$45.40	\$381.42	\$675.21	(\$356.63)
1600 - SUMMER SCHOOL PROGRAMS					
200 - EMPLOYEE BENEFITS	\$500.00	\$0.00	\$130.27	\$0.00	\$369.73
1800 - BILINGUAL PROGRAMS					
200 - EMPLOYEE BENEFITS	\$200.00	\$17.45	\$44.75	\$33.51	\$121.74
2130 - HEALTH SERVICES					
200 - EMPLOYEE BENEFITS	\$13,000.00	\$824.81	\$7,001.71	\$3,875.04	\$2,123.25
2190 - OTHER SUPPORT SERVICES - PUPILS					
200 - EMPLOYEE BENEFITS	\$500.00	\$56.92	\$238.33	\$109.18	\$152.49
2210 - IMPROVEMENT OF INSTRUCTION					
200 - EMPLOYEE BENEFITS	\$5,000.00	\$394.66	\$3,238.26	\$1,775.98	(\$14.24)
2330 - ADMINISTRATIVE SERVICES SPECIAL ED					
200 - EMPLOYEE BENEFITS	\$1,600.00	\$121.62	\$997.89	\$547.29	\$54.82
2410 - PRINCIPAL					
200 - EMPLOYEE BENEFITS	\$14,400.00	\$1,095.65	\$9,042.45	\$4,244.06	\$1,113.49
2520 - FISCAL SERVICES					
200 - EMPLOYEE BENEFITS	\$19,000.00	\$1,484.02	\$12,181.12	\$6,678.10	\$140.78
2540 - OPERATIONS & MAINTENANCE OF PLANTS					
200 - EMPLOYEE BENEFITS	\$43,700.00	\$3,861.27	\$27,574.12	\$13,848.78	\$2,277.10
2560 - FOOD SERVICES					
200 - EMPLOYEE BENEFITS	\$22,838.00	\$1,781.03	\$11,451.68	\$6,700.04	\$4,686.28
2630 - INFORMATION SERVICES					
200 - EMPLOYEE BENEFITS	\$6,500.00	\$479.06	\$3,930.57	\$2,155.77	\$413.66
2660 - OTHER SUPPORT SERVICES - PUPILS					
200 - EMPLOYEE BENEFITS	\$31,300.00	\$2,432.70	\$19,091.75	\$10,684.25	\$1,524.00
<b>51 - IMRF Total:</b>	<b>\$194,638.00</b>	<b>\$16,339.23</b>	<b>\$117,166.30</b>	<b>\$66,375.11</b>	<b>\$11,096.59</b>

# Lincolnwood School District 74

## General Ledger - OBJECT REPORT

Fiscal Year: 2023-2024 From Date: 2/1/2024 To Date: 2/29/2024

Account Mask: ??????????????????

Account Type: EXPENDITURE

Print accounts with zero balance     
  Include Inactive Accounts     
  Include PreEncumbrance

FUND / TYPE / FUNCTION / OBJECT	Preliminary 2024	Range To Date	Year To Date	Encumbrance	Budget Balance
52 - SOCIAL SECURITY AND MEDICARE					
0 - EXPENDITURES					
1100 - REGULAR K-12 PROGRAMS					
200 - EMPLOYEE BENEFITS	\$123,940.00	\$9,440.26	\$61,132.40	\$55,241.87	\$7,565.73
1125 - PRE-K PROGRAMS					
200 - EMPLOYEE BENEFITS	\$6,300.00	\$430.38	\$2,796.05	\$2,327.96	\$1,175.99
1200 - SPECIAL ED PROGRAMS K-12					
200 - EMPLOYEE BENEFITS	\$38,100.00	\$3,621.55	\$22,271.01	\$17,150.03	(\$1,321.04)
1250 - REMEDIAL & SUPPLEMENTAL K-12					
200 - EMPLOYEE BENEFITS	\$8,271.00	\$635.09	\$4,153.29	\$4,148.46	(\$30.75)
1500 - INTERSCHOLASTIC PROGRAMS					
200 - EMPLOYEE BENEFITS	\$2,500.00	\$59.96	\$1,115.26	\$1,099.33	\$285.41
1600 - SUMMER SCHOOL PROGRAMS					
200 - EMPLOYEE BENEFITS	\$1,900.00	\$0.00	\$1,028.29	\$0.00	\$871.71
1650 - GIFTED PROGRAMS					
200 - EMPLOYEE BENEFITS	\$6,803.00	\$512.09	\$3,387.91	\$3,350.90	\$64.19
1800 - BILINGUAL PROGRAMS					
200 - EMPLOYEE BENEFITS	\$9,834.00	\$764.28	\$4,805.21	\$4,763.69	\$265.10
2110 - ATTENDANCE & SOCIAL WORK					
200 - EMPLOYEE BENEFITS	\$5,784.00	\$443.02	\$2,890.59	\$2,889.09	\$4.32
2130 - HEALTH SERVICES					
200 - EMPLOYEE BENEFITS	\$11,510.00	\$759.44	\$6,875.22	\$3,538.86	\$1,095.92
2140 - PSYCHOLOGICAL SERVICES					
200 - EMPLOYEE BENEFITS	\$2,485.00	\$190.20	\$1,244.70	\$1,243.58	(\$3.28)
2150 - SPEECH PATHOLOGY & AUDIOLOGY					
200 - EMPLOYEE BENEFITS	\$3,843.00	\$256.72	\$1,732.78	\$1,680.60	\$429.62
2190 - OTHER SUPPORT SERVICES - PUPILS					
200 - EMPLOYEE BENEFITS	\$4,920.00	\$558.07	\$2,959.21	\$1,099.41	\$861.38
2210 - IMPROVEMENT OF INSTRUCTION					
200 - EMPLOYEE BENEFITS	\$9,247.00	\$701.68	\$6,115.78	\$3,098.84	\$32.38
2220 - EDUCATIONAL MEDIA					
200 - EMPLOYEE BENEFITS	\$3,968.00	\$304.86	\$1,971.19	\$1,975.20	\$21.61
2320 - SUPERINTENDENT					
200 - EMPLOYEE BENEFITS	\$4,000.00	\$288.26	\$2,465.05	\$1,297.67	\$237.28
2330 - ADMINISTRATIVE SERVICES SPECIAL ED					

**Lincolnwood School District 74**

**General Ledger - OBJECT REPORT**

Fiscal Year: 2023-2024 From Date:2/1/2024 To Date:2/29/2024

Account Mask: ????????????????????

Account Type: EXPENDITURE

Print accounts with zero balance     
  Include Inactive Accounts     
  Include PreEncumbrance

FUND / TYPE / FUNCTION / OBJECT	Preliminary 2024	Range To Date	Year To Date	Encumbrance	Budget Balance
200 - EMPLOYEE BENEFITS	\$3,303.00	\$253.02	\$2,160.43	\$1,144.89	(\$2.32)
2410 - PRINCIPAL					
200 - EMPLOYEE BENEFITS	\$18,918.00	\$1,508.96	\$12,759.63	\$6,334.57	(\$176.20)
2510 - DIRECTION OF BUSINESS SUPPORT SERVICES					
200 - EMPLOYEE BENEFITS	\$2,850.00	\$218.42	\$1,861.15	\$983.99	\$4.86
2520 - FISCAL SERVICES					
200 - EMPLOYEE BENEFITS	\$16,159.00	\$1,217.60	\$10,509.11	\$5,586.22	\$63.67
2540 - OPERATIONS & MAINTENANCE OF PLANTS					
200 - EMPLOYEE BENEFITS	\$39,373.00	\$3,867.32	\$26,472.65	\$14,254.35	(\$1,354.00)
2560 - FOOD SERVICES					
200 - EMPLOYEE BENEFITS	\$18,220.00	\$1,750.45	\$13,984.83	\$6,278.51	(\$2,043.34)
2630 - INFORMATION SERVICES					
200 - EMPLOYEE BENEFITS	\$6,009.00	\$462.14	\$3,928.19	\$2,079.63	\$1.18
2660 - OTHER SUPPORT SERVICES - PUPILS					
200 - EMPLOYEE BENEFITS	\$29,145.00	\$2,295.94	\$18,915.91	\$10,291.31	(\$62.22)
52 - SOCIAL SECURITY AND MEDICARE Total:	\$377,382.00	\$30,539.71	\$217,535.84	\$151,858.96	\$7,987.20

**Lincolnwood School District 74**

**General Ledger - OBJECT REPORT**

Fiscal Year: 2023-2024 From Date:2/1/2024 To Date:2/29/2024

Account Mask: ????????????????????

Account Type: EXPENDITURE

Print accounts with zero balance       Include Inactive Accounts       Include PreEncumbrance

FUND / TYPE / FUNCTION / OBJECT

Preliminary 2024      Range To Date      Year To Date      Encumbrance      Budget Balance

60 - CAPITAL PROJECTS

0 - EXPENDITURES

2530 - FACILITY ACQUISITION & CONSTRUCTION

FUND / TYPE / FUNCTION / OBJECT	Preliminary 2024	Range To Date	Year To Date	Encumbrance	Budget Balance
300 - PURCHASED SERVICES	\$269,504.00	\$0.00	\$275,187.41	\$0.00	(\$5,683.41)
500 - CAPITAL OUTLAY	\$1,689,139.00	\$29,088.90	\$1,422,945.46	\$0.00	\$266,193.54
<b>60 - CAPITAL PROJECTS Total:</b>	<b>\$1,958,643.00</b>	<b>\$29,088.90</b>	<b>\$1,698,132.87</b>	<b>\$0.00</b>	<b>\$260,510.13</b>

Lincolnwood School District 74

General Ledger - OBJECT REPORT

Fiscal Year: 2023-2024 From Date:2/1/2024 To Date:2/29/2024

Account Mask: ????????????????????

Account Type: EXPENDITURE

Print accounts with zero balance     
  Include Inactive Accounts     
  Include PreEncumbrance

FUND / TYPE / FUNCTION / OBJECT

Preliminary 2024    Range To Date    Year To Date    Encumbrance    Budget Balance

80 - TORT IMMUNITY

    0 - EXPENDITURES

        2362 - WORKERS COMPENSATION INSURANCE

300 - PURCHASED SERVICES	\$75,800.00	\$0.00	\$8,655.00	\$0.00	\$67,145.00
--------------------------	-------------	--------	------------	--------	-------------

        2371 - PROPERTY INSURANCE

300 - PURCHASED SERVICES	\$120,000.00	\$0.00	\$0.00	\$0.00	\$120,000.00
--------------------------	--------------	--------	--------	--------	--------------

80 - TORT IMMUNITY Total:	\$195,800.00	\$0.00	\$8,655.00	\$0.00	\$187,145.00
---------------------------	--------------	--------	------------	--------	--------------

**Lincolnwood School District 74**

**General Ledger - OBJECT REPORT**

Fiscal Year: 2023-2024 From Date:2/1/2024 To Date:2/29/2024

Account Mask: ??????????????????

Account Type: EXPENDITURE

Print accounts with zero balance     
  Include Inactive Accounts     
  Include PreEncumbrance

FUND / TYPE / FUNCTION / OBJECT

Preliminary 2024    Range To Date    Year To Date    Encumbrance    Budget Balance

90 - FIRE PREVENTION & SAFETY

    0 - EXPENDITURES

        2530 - FACILITY ACQUISITION & CONSTRUCTION

300 - PURCHASED SERVICES	\$46,000.00	\$0.00	\$34,370.90	\$0.00	\$11,629.10
--------------------------	-------------	--------	-------------	--------	-------------

        2540 - OPERATIONS & MAINTENANCE OF PLANTS

500 - CAPITAL OUTLAY	\$1,435,362.00	\$0.00	\$1,265,859.79	\$0.00	\$169,502.21
----------------------	----------------	--------	----------------	--------	--------------

90 - FIRE PREVENTION & SAFETY Total:	\$1,481,362.00	\$0.00	\$1,300,230.69	\$0.00	\$181,131.31
--------------------------------------	----------------	--------	----------------	--------	--------------

Lincolnwood School District 74

General Ledger - OBJECT REPORT

Fiscal Year: 2023-2024 From Date:2/1/2024 To Date:2/29/2024

Account Mask: ????????????????????

Account Type: EXPENDITURE

- Print accounts with zero balance
- Include Inactive Accounts
- Include PreEncumbrance

FUND / TYPE / FUNCTION / OBJECT	Preliminary 2024	Range To Date	Year To Date	Encumbrance	Budget Balance
Grand Total:	\$33,861,000.00	\$2,042,012.71	\$19,786,551.52	\$8,965,914.99	\$5,108,533.49

End of Report

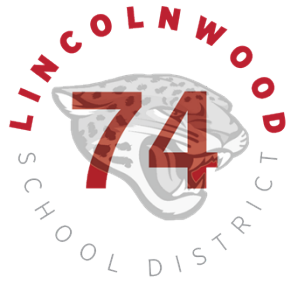

## Executive Summary Finance Committee Meeting

---

DATE: April 18, 2024

TOPIC: Final Fiscal Year 2023 Single Audit by Lauterbach & Amen, LLP

PREPARED BY: Courtney Whited

### **Recommended for:**

Action

Discussion

Information

### **Purpose/Background:**

Lauterbach & Amen prepared the FY2023 Single Audit which was necessary due to the amount of Elementary and Secondary School Emergency Relief (ESSER) Federal funds SD74 received during that fiscal year. The deadline for submission to the Federal Audit Clearinghouse is March 31, 2024. No issues were cited by Lauterbach & Amen in this report.

### **Fiscal Impact:**

None

### **Recommendation:**

This summary is for informational purposes. The final Fiscal Year 2023 Single Audit Report prepared by Lauterbach & Amen, LLP will be presented to the Lincolnwood School District 74 Board of Education for review at the May 2, 2023 Board of Education meeting, as recommended by the Finance Committee.

LINCOLNWOOD SCHOOL  
DISTRICT 74, ILLINOIS

---

SINGLE AUDIT REPORT

FOR THE FISCAL YEAR ENDED  
JUNE 30, 2023

**LINCOLNWOOD SCHOOL DISTRICT 74, ILLINOIS**

**TABLE OF CONTENTS**

---

---

<b>SCHEDULE OF EXPENDITURES OF FEDERAL AWARDS</b>	1
<b>NOTES TO THE SCHEDULE OF EXPENDITURES OF FEDERAL AWARDS</b>	2
<b>REPORTS OF INDEPENDENT AUDITORS</b>	
Report on Internal Control Over Financial Reporting and on Compliance and Other Matters Based on an Audit of Financial Statements Performed in Accordance With <i>Government Auditing Standards</i>	3
Report on Compliance for Each Major Program and on Internal Control Over Compliance Required by Uniform Guidance and on the Schedule of Expenditures of Federal Awards	5
<b>SCHEDULE OF FINDINGS AND QUESTIONED COSTS</b>	8

LINCOLNWOOD SCHOOL DISTRICT 74, ILLINOIS

Schedule of Expenditures of Federal Awards  
For the Year Ended June 30, 2023

Cluster Name/ Federal Grantor	Pass-Through Grantor	Program Title	Assistance		Amount Provided to Subrecipients
			Listing Number	Program/Grant Number	
<b>Child Nutrition Cluster</b>					
Department of Agriculture	Illinois State Board of Education	Special Milk Program	10.556	2022-4215	\$ 2,643
			10.556	2023-4215	15,093
				<b>Total 10.556</b>	<b>17,736</b>
<b>Special Education (IDEA) Cluster</b>					
Department of Education	Illinois State Board of Education	IDEA - Flow Through Pre-School	84.173	2023-4600	10,252
		IDEA - Flow Through	84.027	2023-4620	304,944
		IDEA - Room & Board	84.027	2022-4625	58,171
			84.027	2023-4625	97,347
				<b>Total IDEA Cluster</b>	<b>470,714</b>
<b>Medical Cluster</b>					
Department of Health and Human Services	Illinois Department of Healthcare and Human Services	Medical Assistance Program	93.778	2023-4991	48,412
<b>Other Programs</b>					
Department of Education	Illinois State Board of Education	Title I - Low Income	84.010	2023-4300	286,398
Department of Education	Illinois State Board of Education	Title III - Lang Inst Prog- Limited Eng LIPLEP	84.365A	2023-4909	24,033
Department of Education	Illinois State Board of Education	Title I - School Improvement & Accountability	84.010A	2023-4331-PL	14,146
Department of Education	Illinois State Board of Education	Elementary and Secondary School Emergency Relief Fund	84.425D	2023-4998-E2	126,881
			84.425U	2023-4998-E3	900,047
			84.425U	2023-4998-FB	805
				<b>Total 84.425D</b>	<b>1,027,733 *</b>
					<b>1,889,172</b>
<b>TOTAL FEDERAL AWARDS EXPENDED</b>					

\*Denotes major federal program

See accompanying notes to the schedule of expenditures of federal awards.

## LINCOLNWOOD SCHOOL DISTRICT 74, ILLINOIS

### Notes to the Schedule of Expenditures of Federal Awards June 30, 2023

---

#### **NOTE 1 – BASIS OF PRESENTATION**

The accompanying schedule of expenditures of federal awards (the Schedule) includes the federal grant activity of the School District under programs of the federal government for the year ended June 30, 2023. The information in this Schedule is presented in accordance with the requirements of Uniform Guidance, *Audits of States, Local Governments, and Non-Profit Organizations*. Because the Schedule presents only a selected portion of the operations of the School District, it is not intended to and does not present the financial position, changes in net position, or cash flows of the School District.

#### **NOTE 2 – SUMMARY OF SIGNIFICANT ACCOUNTING POLICIES**

##### **Expenditures**

Expenditures reported on the Schedule are reported on the accrual basis of accounting.

##### **Pass-Through Entities**

Pass-through entity identifying numbers are presented on the Schedule where available.

#### **NOTE 3 – 10% DE MINIMIS INDIRECT COST RATE**

The School District has selected to use a rate other than the 10% de minimis indirect cost rate as permitted by 2 CFR Section 200.414.

#### **NOTE 4 – NONCASH TRANSACTIONS**

The School District received \$0 of Federal non-cash commodities passed through the Illinois State Board of Education.

#### **NOTE 5 – SUBRECIPIENT RELATIONSHIPS**

The School District did not remit any funds to subrecipients.



**INDEPENDENT AUDITORS' REPORT  
ON INTERNAL CONTROL OVER FINANCIAL REPORTING AND ON COMPLIANCE  
AND OTHER MATTERS BASED ON AN AUDIT OF FINANCIAL STATEMENTS  
PERFORMED IN ACCORDANCE WITH *GOVERNMENT AUDITING STANDARDS***

October 31, 2023

Members of the Board of Education  
Lincolnwood School District 74  
Lincolnwood, Illinois

We have audited, in accordance with the auditing standards generally accepted in the United States of America and the standards applicable to financial audits contained in *Government Auditing Standards* issued by the Comptroller General of the United States, the financial statements of the governmental activities, each major fund, and the aggregate remaining fund information of the Lincolnwood School District 74, (the District), Illinois, as of and for the year ended June 30, 2023, and the related notes to the financial statements, which collectively comprise the District's basic financial statements, and have issued our report thereon dated October 31, 2023.

*Report on Internal Control over Financial Reporting*

In planning and performing our audit of the financial statements, we considered the District's internal control over financial reporting (internal control) as a basis for designing audit procedures that are appropriate in the circumstances for the purpose of expressing our opinions on the financial statements, but not for the purpose of expressing an opinion on the effectiveness of District's internal control. Accordingly, we do not express an opinion on the effectiveness of District's internal control.

A *deficiency in internal control* exists when the design or operation of a control does not allow management or employees, in the normal course of performing their assigned functions, to prevent, or detect and correct, misstatements, on a timely basis. A *material weakness* is a deficiency, or a combination of deficiencies, in internal control, such that there is a reasonable possibility that a material misstatement of the District's financial statements will not be prevented, or detected and corrected, on a timely basis. A *significant deficiency* is a deficiency, or a combination of deficiencies, in internal control that is less severe than a material weakness, yet important enough to merit attention by those charged with governance.

Our consideration of internal control was for the limited purpose described in the first paragraph of this section and was not designed to identify all deficiencies in internal control that might be material weaknesses or, significant deficiencies. Given these limitations, during our audit we did not identify any deficiencies in internal control that we consider to be material weaknesses. However, material weaknesses or significant deficiencies may exist that were not identified.

Lincolnwood School District 74, Illinois  
October 31, 2023

*Reporting on Compliance and Other Matters*

As part of obtaining reasonable assurance about whether the District's financial statements are free from material misstatement, we performed tests of its compliance with certain provisions of laws, regulations, contracts, and grant agreements, noncompliance with which could have a direct and material effect on the financial statements. However, providing an opinion on compliance with those provisions was not an objective of our audit, and accordingly, we do not express such an opinion. The results of our tests disclosed no instances of noncompliance or other matters that are required to be reported under *Government Auditing Standards*.

We noted certain other matters that we reported to management of the District in a separate letter dated October 31, 2023

*Purpose of this Report*

The purpose of this report is solely to describe the scope of our testing of internal control and compliance and the results of that testing, and not to provide an opinion on the effectiveness of the District's internal control or on compliance. This report is an integral part of an audit performed in accordance with *Government Auditing Standards* in considering the District's internal control and compliance. Accordingly, this communication is not suitable for any other purpose.

*Lauterbach & Amen, LLP*  
LAUTERBACH & AMEN, LLP



**INDEPENDENT AUDITORS' REPORT  
ON COMPLIANCE FOR EACH MAJOR PROGRAM AND ON INTERNAL CONTROL OVER  
COMPLIANCE REQUIRED BY UNIFORM GUIDANCE  
AND ON THE SCHEDULE OF EXPENDITURES OF FEDERAL AWARDS**

March 18, 2024

Members of the Board of Education  
Lincolnwood School District 74  
Lincolnwood, Illinois

*Report on Compliance for Each Major Federal Program*

We have audited the Lincolnwood School District 74, (the District), Illinois' compliance with the types of compliance requirements described in the *Uniform Guidance Compliance Supplement* that could have a direct and material effect on each of the District's major federal programs for the year ended June 30, 2023. The District's major federal programs are identified in the summary of auditor's results section of the accompany schedule of findings and questioned costs.

*Management Responsibility*

Management is responsible for compliance with the requirements of laws, regulations, contracts, and grants applicable to its federal programs.

*Auditor's Responsibility*

Our responsibility is to express an opinion on compliance for each of the District's major federal programs based on our audit of the types of compliance requirements referred to above. We conducted our audit of compliance in accordance with auditing standards generally accepted in the United States of America; the standards applicable to financial audits contained in *Government Auditing Standards*, issued by the Comptroller General of the United States; and Uniform Guidance, *Audits of States, Local Governments, and Non-Profit Organizations*. Those standards and Uniform Guidance required that we plan and perform the audit to obtain reasonable assurance about whether noncompliance with the types of compliance requirements referred to above that could have a direct and material effect on a major federal program occurred. An audit includes examining, on a test basis, evidence about the District's compliance with those requirements and performing such other procedures as we considered necessary in the circumstances.

We believe our audit provides a reasonable basis for our opinion on compliance for each major federal program. However, our audit does not provide a legal determination of the District's compliance.

Lincolnwood School District 74, Illinois  
March 18, 2024

*Opinion on Each Major Federal Program*

In our opinion, the Lincolnwood School District 74, Illinois complied, in all material respects, with the types of compliance requirements referred to above that could have a direct and material effect on each of its major federal programs for the year ended June 30, 2023.

*Report on Internal Control over Compliance*

Management of the District is responsible for establishing and maintaining effective internal control over compliance with the types of compliance requirements referred to above. In planning and performing our audit of compliance, we considered the District's internal control over compliance with the types of requirements that could have a direct and material effect on each major federal program to determine the auditing procedures that are appropriate in the circumstances for the purpose of expressing an opinion on compliance for each major federal program and to test and report on internal control over compliance in accordance with Uniform Guidance, but not for the purpose of expressing an opinion on the effectiveness of internal control over compliance. Accordingly, we do not express an opinion on the effectiveness of the District's internal control over compliance.

*A deficiency in internal control over compliance* exists when the design or operation of a control over compliance does not allow management or employees, in the normal course of performing their assigned functions, to prevent, or detect and correct, noncompliance with a type of compliance requirement of a federal program on a timely basis. *A material weakness in internal control over compliance* is a deficiency, or combination of deficiencies, in internal control over compliance, such that there is a reasonable possibility that material noncompliance with a type of compliance requirement of a federal program will not be prevented, or detected and corrected, on a timely basis. *A significant deficiency in internal control over compliance* is a deficiency, or a combination of deficiencies, in internal control over compliance with a type of compliance requirement of a federal program that is less severe than a material weakness in internal control over compliance, yet important enough to merit attention by those charged with governance.

Our consideration of internal control over compliance was for the limited purpose described in the first paragraph of this section and was not designed to identify all deficiencies in internal control over compliance that might be material weaknesses or significant deficiencies. We did not identify any deficiencies in internal control over compliance that we consider to be material weaknesses. However, material weaknesses may exist that have not been identified.

Lincolnwood School District 74, Illinois  
March 18, 2024

*Schedule of Expenditures of Federal Awards*

We have audited the financial statements of the governmental activities, each major fund, and the aggregate remaining fund information of the Lincolnwood School District 74, Illinois as of and for the year ended June 30, 2023, and the related notes to the financial statements, which collectively comprise the District's basic financial statements. We issued our report thereon dated October 31, 2023, which contained unmodified opinions on those financial statements. Our audit was conducted for the purpose of forming opinions on the financial statements that collectively comprise the basic financial statements. The accompanying schedule of expenditures of federal awards is presented for purposes of additional analysis as required by Uniform Guidance and is not a required part of the basic financial statements. Such information is the responsibility of management and was derived from and relates directly to the underlying accounting and other records used to prepare the basic financial statements. The information has been subjected to the auditing procedures applied in the audit of the financial statements and certain additional procedures, including comparing and reconciling such information directly to the underlying accounting and other records used to prepare the basic financial statements or to the basic financial statements themselves, and other additional procedures in accordance with auditing standards generally accepted in the United States of America. In our opinion, the schedule of expenditures of federal awards is fairly stated in all material respects in relation to the basic financial statements as a whole.

The purpose of this report on internal control over compliance is solely to describe the scope of our testing of internal control over compliance and the results of that testing based on the requirements of Uniform Guidance. Accordingly, this report is not suitable for any other purpose.

*Lauterbach & Amen, LLP*  
LAUTERBACH & AMEN, LLP

**LINCOLNWOOD SCHOOL DISTRICT 74, ILLINOIS**

**Schedule of Findings and Questioned Costs  
Year Ended June 30, 2023**

---

---

**SECTION 1 – SUMMARY OF AUDITOR’S RESULTS**

**Financial Statements**

Type of auditor’s report issued on the financial statements: Unmodified

Internal control over financial reporting:  
Material weakness(es) identified: No  
Significant deficiencies identified: No

Noncompliance material to the financial statements noted: No

**Federal Awards**

Type of auditor’s report issued on compliance for major programs: Unmodified

Internal control over major programs:  
Material weakness(es) identified: No  
Significant deficiencies identified: No

Any audit findings disclosed that are required to be reported in accordance with 2 CFR 200.516(a): No

Major programs identified:

<u>ALN Number(s)</u>	<u>Name of Federal Program/Cluster</u>
84.425	Elementary and Secondary School Emergency Relief Fund

Dollar threshold used to distinguish between Type A and Type B programs: \$750,000

Auditee qualified as a low-risk auditee: No

**LINCOLNWOOD SCHOOL DISTRICT 74, ILLINOIS**

**Schedule of Findings and Questioned Costs – Continued  
Year Ended June 30, 2023**

---

---

**SECTION 2 – FINANCIAL STATEMENT AUDIT FINDINGS**

**None**

**LINCOLNWOOD SCHOOL DISTRICT 74, ILLINOIS**

**Schedule of Findings and Questioned Costs – Continued  
Year Ended June 30, 2023**

---

---

**SECTION 3 – FEDERAL AWARD FINDINGS AND QUESTIONED COSTS**

**None**

**LINCOLNWOOD SCHOOL DISTRICT 74, ILLINOIS**

**Schedule of Findings and Questioned Costs – Continued  
Year Ended June 30, 2023**

---

---

**SECTION 4 – PRIOR YEAR AUDIT FINDINGS**

**None**

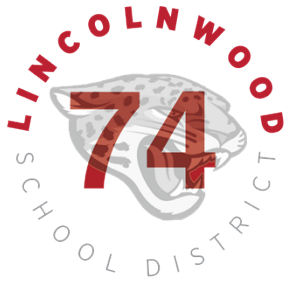

Executive Summary  
Finance Committee Meeting

DATE: April 18, 2024

TOPIC: Transportation Contract Amendment 2024-25 with First Student, Inc.

PREPARED BY: Courtney Whited

**Recommended for:**

- Action
- Discussion
- Information

**Purpose/Background:**

The Board approves all contracts over \$10,000. The District Legal Counsel has reviewed this amendment and found it to be acceptable after the recommended minor edits were made.

**Fiscal Impact:**

A 4.90% rate increase was applied for FY25 transportation services.  
The prior year's increase was 3.75%.

Lincolnwood School District #74		
	2023-24	2024-25
AM Rate per Route - Single	\$140.55	\$147.44
AM Rate per Route - Dual	\$ 70.26	\$73.70
AM Rate per Route - Dual Paired with District 219 credit back to District	\$121.09	\$127.02
PM Rate per Route - Single	\$140.55	\$147.44
PM Rate per Route - Dual	\$ 70.26	\$73.70
PM Rate per Route - Dual Paired with District 219 credit back to District	\$121.09	\$127.02
Mid-Day Rate per Route (Pre-Kindergarten)	\$ 99.15	\$104.01
Before School Activity Rate per route	\$111.86	\$117.34
After School Activity Rate per Route	\$111.86	\$117.34
Extracurricular Charter Rate per hour	\$ 66.10	\$69.34
<b>*The above prices are inclusive of the District 219 equipment surcharge</b>		
District 219 equipment surcharge AM or PM route	\$ 45.63	\$47.87
District 219 equipment surcharge Midday or Activity route	\$ 11.41	\$11.97

**Recommendation:**

The Finance Committee concurs with the Administration's recommendation to the Board of Education to accept this Amendment from First Student, Inc. for transportation services with a 4.90% rate increase on current rates effective August 1, 2024 through July 31, 2025.

**AMENDMENT AND EXTENSION TO THE PUPIL TRANSPORTATION SERVICES  
AGREEMENT BETWEEN  
LINCOLNWOOD SCHOOL DISTRICT 74 AND FIRST STUDENT, INC.**

**THIS AMENDMENT** ("Amendment") Is made by and effective as of the 2<sup>nd</sup> day of May, 2024, by and between Lincolnwood School District 74, with principal offices at 6950 N. East Prairie Road Lincolnwood, IL 60712, (the "District") and First Student, Inc., with Its national headquarters at 191 Rosa Parks Street, Cincinnati, OH 45202 and principal business offices for purposes of this Amendment located at 1717 Park Street, Suite 225, Naperville, IL 60563 (the "Contractor" and, collectively, the "Parties").

**WHEREAS**, the Contractor was the successful bidder on March 16, 2015 and operated the student transportation services for the DISTRICT for the school years of 2015-16 through 2017-18 per the specifications provided in the bid process and all contingencies placed upon the bid specifications by the Contractor in its proposal and executive summary (the "Agreement").

**WHEREAS**, the Parties previously amended certain provisions of the Agreement and extended its term annually effective August 1, 2018, August 1, 2020, August 1, 2021, August 1, 2022, and August 1, 2023, respectively.

**WHEREAS**, the Parties desire to amend certain provisions of the Agreement again and extend its term effective August 1, 2024.

**NOW, THEREFORE**, the Parties mutually agree as follows:

All terms used herein, unless otherwise defined in this Amendment, shall have the same meaning as set forth in the Agreement. Following the effective date of this Amendment, future references to the Agreement in any communication or document between the District and Contractor shall mean the Agreement incorporating the changes and/or additions in this Amendment.

- 1. TERM:** The term of the Agreement shall extend for one additional year commencing August 1, 2024 and continuing through July 31, 2025.
- 2. COMPENSATION:** Commencing August 1, 2024, the rates of compensation will increase by 4.9% for the 2024-25 school year. Rates are listed in attached Exhibit A and are based on the current number of routes.
- 3. ENTIRE AGREEMENT:** The terms of this Amendment, the original Agreement, and all other amendments set forth the entire Agreement between District and Contractor concerning the subject matter hereof. To the extent that the terms of this Amendment supplement, amend or replace terms from the original Agreement, the terms of this Amendment shall control.

**4. NOTICE TO PARTIES:** All notices to be given by the parties to this Agreement shall be in writing and serviced by depositing same in the United States Mail, certified mail.

Notices to District shall be addressed to:

Courtney Whited  
Business Manager/CSBO  
Lincolnwood School District 74  
6950 N. East Prairie Rd.  
Lincolnwood, IL 60712

Notices to Contractor shall be addressed to:

Mike Tunnell  
District Manager  
First Student, Inc.  
1717 Park Street  
Suite 225  
Naperville, IL 60563

With a copy to:

General Counsel  
First Student, Inc.  
191 Rosa Parks  
Street 8<sup>th</sup> Floor  
Cincinnati, OH 45202

**IN WITNESS WHEREOF**, this Amendment has been signed and executed in duplicate on behalf of the parties hereto by persons duly authorized on the day and year first written above.

Lincolnwood School District 74

FIRST STUDENT, INC.

By: \_\_\_\_\_

By: \_\_\_\_\_

Title: \_\_\_\_\_

Title: \_\_\_\_\_

ATTEST:

By: \_\_\_\_\_

By: \_\_\_\_\_

**Exhibit A**

<b>Lincolnwood School District #74</b>		
	<b>2023-24</b>	<b>2024-25</b>
AM Rate per Route - Single	\$140.55	\$147.44
AM Rate per Route - Dual	\$ 70.26	\$73.70
AM Rate per Route - Dual Paired with District 219 credit back to District	\$121.09	\$127.02
PM Rate per Route - Single	\$140.55	\$147.44
PM Rate per Route - Dual	\$ 70.26	\$73.70
PM Rate per Route - Dual Paired with District 219 credit back to District	\$121.09	\$127.02
Mid-Day Rate per Route (Pre-Kindergarten)	\$ 99.15	\$104.01
Before School Activity Rate per route	\$111.86	\$117.34
After School Activity Rate per Route	\$111.86	\$117.34
Extracurricular Charter Rate per hour	\$ 66.10	\$69.34
<b>*The above prices are inclusive of the District 219 equipment surcharge</b>		
District 219 equipment surcharge AM or PM route	\$ 45.63	\$47.87
District 219 equipment surcharge Midday or Activity route	\$ 11.41	\$11.97

## TRANSPORTATION CONTRACT

AGREEMENT made the 29<sup>th</sup> day of April, 2015, between  
Lincolnwood SCHOOL DISTRICT FIRST STUDENT, INC.  
(hereinafter referred to as the "District") and ~~CONTRACTOR, INC.~~ (hereinafter referred to  
as the "Contractor").

### Term of Contract.

The Contractor, for and in consideration of the payments to be made as hereinafter set forth in the Cost Schedule attached hereto as Appendix A, hereby agrees to transport students that the District must transport by law and students that have independently agreed to pay for transportation to and from the schools of the Districts and all special routes as defined herein as well as all students requiring transportation for extracurricular activities including activity trips, field trips, and transportation for such events as are required by the Board or its authorized agent from August 1, 2015, through July 31, 2018. The term of this contract may be extended at the option of the District for two (2) additional one (1) year periods. Notice of the extension of the contract shall be provided to the Contractor in writing not later than March 31<sup>st</sup> of the year of termination.

### Local Office and On-Duty Dispatcher/Manager.

The Contractor shall maintain a local bus office parking lot and bus garage within Niles Township or within a ten-mile radius of the intersection of Skokie Boulevard and Oakton Street in Skokie, Illinois. The local office shall be staffed with a manager and at least one dispatcher from 6:00 a.m. to 6:00 p.m. on school days. When buses are in use outside of this time period, a dispatcher or manager will be available by cell phone and pager within five (5) minutes to respond to concerns of the School District.

Indicate the location where the buses will be housed and maintained. The facility must house all functions, including storage of buses, maintenance and dispatch operations of the contractor.

### Contract Documents.

The "Contract Documents" shall consist of this Agreement, the Bid Specifications (including but not limited to the Instructions to Bidders, References, all requisite certifications, bid and performance bonds, insurance, and bid form), the Cost Schedule attached as Appendix A. Appendix C and D to this document are merely to assist in the bidding process, and shall not be deemed binding contractual requirements. The Bid Specifications and the Cost Schedule are hereby incorporated into this Agreement as though they were fully set forth herein and shall have the same force and effect as any other provision in this Agreement. In the event of a conflict between the Bid Specifications and this Agreement, the Bid Specifications shall prevail. Upon award of this Contract, the Bid Specifications will be attached hereto as Appendix B, and the Cost Schedule is attached hereto as Appendix A. In attaching, it is the intent of the parties that both appendices are hereby made a part of this Agreement.

**Hold Harmless Agreement**

The Contractor agrees to indemnify, hold harmless, and defend the Boards of Education of Districts, its officials, employees and agents from and against all suits, actions, legal proceedings, claims, demands, damages, losses, and expenses, including attorneys' fees, in any manner caused by, arising from, incident to, connected with or growing out of the operation of school buses and other vehicles used to transport students under this Contract, in accordance with the liability insurance policies procured by Contractor under this Agreement. Said policies are subject to review and approval by the District.

**Document Supremacy**

In the event any term or provision of one Contract Document conflicts with a term or provision of another, the term or provision of the Contract shall prevail over all other documents. The terms and provisions of the bid specifications shall prevail over the bid sheet.

**Compensation**

Contractor shall provide all services as awarded by District and shall be compensated according to the terms of the bid specifications and the Attachments in the amounts listed in the bid sheet submitted by Contractor.

**Complete Understanding**

This Agreement sets forth all of the promises, agreements, conditions, and understandings between the parties relative to the subject matter hereof, and no other promises, agreements, or understandings, whether oral or written, expressed or implied, exist between the parties.

**Amendments**

No subsequent alteration, amendment, change, addition, deletion, or modification to this Agreement shall be binding upon the parties hereto unless reduced to writing and duly authorized and signed by each of them.

WHEREAS, the Parties have duly executed and entered into this Contract as of the day and year set forth above.

BOARD OF EDUCATION

FIRST STUDENT, INC.  
CONTRACTOR, INC.

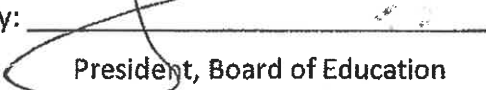
By:   
\_\_\_\_\_  
President, Board of Education

By:   
\_\_\_\_\_  
Authorized Representative

Attest:   
\_\_\_\_\_  
Secretary, Board of Education

Attest:   
\_\_\_\_\_

## Appendix A

<b>Lincolnwood School District #74</b>	<b>2015-16</b>	<b>2016-17</b>	<b>2017-18</b>
AM Rate per Route - Single	\$106.31	\$108.44	\$110.61
AM Rate per Route - Dual	\$53.16	\$54.22	\$55.30
AM Rate per Route - Dual Paired with District 219 \$40 credit back to District 219	\$93.16	\$94.22	\$95.30
PM Rate per Route - Single	\$106.31	\$108.44	\$110.61
PM Rate per Route - Dual	\$53.16	\$54.22	\$55.30
PM Rate per Route - Dual Paired with District 219 \$40 credit back to District 219	\$93.16	\$94.22	\$95.30
Mid-day Rate per Route (Pre-Kindergarten)	\$75.00	\$76.50	\$78.03
Before School Activity Rate per route	\$75.00	\$76.50	\$78.03
After School Activity Rate per Route	\$75.00	\$76.50	\$78.03
Extracurricular Charter Rate per hour	\$50.00	\$51.00	\$52.02

Niles Township High School District 219

Regular Education Only	2015-16	2016-17	2017-18	School Days	Number Routes	2015-16	2016-17	2017-18	Total	
AM Rate per Route - Single	106.31	108.44	110.61	176	25	467,764	477,136	486,684	1,431,584	
AM Rate per Route - Dual (1)	13.16	14.22	15.30	176	24	55,588	60,065	64,627	180,280	
PM Rate per Route - Single	106.31	108.44	110.61	176	27	505,185	515,307	525,619	1,546,111	
PM Rate per Route - Dual (1)	13.16	14.22	15.30	176	13	30,110	32,535	35,006	97,652	
After School Activity Rate per Route(170 DAYS)	75.00	76.50	78.03	170	20	255,000	260,100	265,302	780,402	
Athletic Extracurricular Rate per hour (3 hour minimum) (3)	35.00	35.70	36.41							
Athletic Extracurricular Rate per 5 hour trip, 6 routes/day (3)	175.00	178.50	182.07	170	6	178,500	182,070	185,711	546,281	
Educational Field Trip Extracurricular Rate per Route(3 hour trip) (3)	105.00	107.10	109.24	170	6	107,100	109,242	111,425	327,767	
Field Trip hourly Rate for each hour over 3 hours (3)	35.00	35.70	36.41							
Field Trip/Athletic Surcharge for each mile over 50 miles one-way	0.86	0.88	0.90							
Total District 219										
										4,910,077

Lincroft School District #74	2015-16	2016-17	2017-18	School Days	Number Routes	2015-16	2016-17	2017-18	Total	
AM Rate per Route - Single	106.31	108.44	110.61	176	0	0	0	0	0	
AM Rate per Route - Dual (2)	53.16	54.22	55.30	176	16	149,699	152,684	155,725	458,107	
AM Rate per Route - Dual Paired with District 219 \$40 credit back to District 219	93.16	94.22	95.30	176	8	131,169	132,662	134,182	398,013	
PM Rate per Route - Single	106.31	108.44	110.61	176	0	0	0	0	0	
PM Rate per Route - Dual (2)	53.16	54.22	55.30	176	16	149,699	152,684	155,725	458,107	
PM Rate per Route - Dual Paired with District 219 \$40 credit back to District 219	93.16	94.22	95.30	176	8	131,169	132,662	134,182	398,013	
Mid-day Rate per Route (Pre-kindergarten)	75.00	76.50	78.03	170	2	25,500	26,010	26,530	78,040	
Before School Activity Rate per route	75.00	76.50	78.03	176	4	52,800	53,856	54,933	161,589	
After School Activity Rate per route	75.00	76.50	78.03	170	2	25,500	26,010	26,530	78,040	
Extracurricular Charter Rate per hour	50.00	51.00	52.02	176						
Total District 74										
										2,029,910

Morton Grove School District #70	2015-16	2016-17	2017-18	School Days	Number Routes	2015-16	2016-17	2017-18	Total	
AM Rate per Route - Single	106.31	108.44	110.61	176	0	0	0	0	0	
AM Rate per Route - Dual Paired with District 219 \$40 credit back to District 219	93.16	94.22	95.30	176	11	180,358	182,410	184,501	547,268	
PM Rate per Route - Single	106.31	108.44	110.61	176	8	149,684	152,684	155,739	458,107	
PM Rate per Route - Single using District 219 equipment \$40 credit back to District 219	146.31	148.44	150.61	176	3	77,252	78,376	79,522	235,150	
Mid-day Rate per Route - Dual Paired with District 219	93.16	94.22	95.30	176	0	0	0	0	0	
After School Activity Rate per Route using District 219 equipment \$10 credit back to District 219	85.00	86.50	88.03	176	2	29,920	30,448	30,987	91,355	
Extracurricular Charter Rate per hour	50.00	51.00	52.02	176						
Total Districts 70										
										1,331,880
Niles School District #71	2015-16	2016-17	2017-18	School Days	Number Routes	2015-16	2016-17	2017-18	Total	
AM Rate per Route - Single	106.31	108.44	110.61	176	0	0	0	0	0	
AM Rate per Route - Dual Paired with District 219 \$40 credit back to District 219	93.16	94.22	95.30	176	5	81,981	82,914	83,864	248,758	
PM Rate per Route - Single	106.31	108.44	110.61	176	0	0	0	0	0	
PM Rate per Route - Dual Paired with District 219 \$40 credit back to District 219	93.16	94.22	95.30	176	5	81,981	82,914	83,864	248,758	
After School Activity Rate per Route using District 219 equipment \$10 credit back to District 219	85.00	86.50	88.03	144	1	12,240	12,456	12,676	37,372	
Extracurricular Charter Rate per hour	50.00	51.00	52.02	176						
Total Districts 71										
										534,889

(1) Assumes route bus transports one high school route and one elementary school route per am or pm dispatch.

(2) Assumes two individual elementary routes share the same routed bus and results in two separate charges per am or pm dispatch.

(3) Assumes trip is operated with District 219 bus. In the event a First Student bus is used, then the rate becomes \$50 per hour in year one (1)

Total Bid

8,806,756

1  
2  
3  
4  
5  
6  
7  
8  
9  
10  
11  
12  
13  
14  
15  
16  
17  
18  
19  
20  
21  
22  
23  
24  
25  
26  
27  
28  
29  
30  
31  
32  
33  
34  
35  
36  
37  
38  
39  
40  
41  
42  
43  
44  
45  
46  
47  
48  
49  
50  
51  
52  
53  
54  
55  
56  
57  
58  
59  
60  
61  
62  
63  
64  
65  
66  
67  
68  
69  
70  
71  
72  
73  
74  
75  
76  
77  
78  
79  
80  
81  
82  
83  
84  
85  
86  
87  
88  
89  
90  
91  
92  
93  
94  
95  
96  
97  
98  
99  
100

**NILES TOWNSHIP HIGH SCHOOL DISTRICT 219, MORTON GROVE SCHOOL DISTRICT 70,  
NILES SCHOOL DISTRICT 71, AND LINCOLNWOOD SCHOOL DISTRICT 74**

**SPECIFICATIONS FOR STUDENT BUS TRANSPORTATION**

**BID OPENING DATE: MARCH 16, 2015 2:00 P.M.**

**INSTRUCTIONS TO BIDDERS:**

1. NOTICE IS HEREBY GIVEN that proposals for a three (3) year contract for general education transportation services for Niles Township High School District 219, Morton Grove School District 70, Niles School District 71, and Lincolnwood School District 74 (collectively, "Districts") will be opened and read in the Niles Township High School District Administrative Office located at 7700 Gross Point Road (Board Room), Skokie, Illinois 60077, at the time and date indicated above. The contract period, if awarded, will be for the school years 2015-2016, 2016-2017, and 2017-2018 with extensions to be allowed as provided under Illinois School Code. The contract will start on August 1, 2015.
  
2. Questions and Clarifications: Bidders must satisfy themselves, upon examination of the specifications, of the intent of the specifications. Any questions, discrepancies, omissions, ambiguities or conflicts in the contract documents should be in writing and brought to the attention of Mr. Eric Trimberger, Assistant Superintendent for Business/CSBO, at eritri@d219.org.
  
3. The sealed proposals shall be delivered to Mr. Eric Trimberger, Assistant Superintendent for Business/CSBO at Niles Township High School District 219, 7700 Gross Point Road, Skokie 60077 at any time prior to but not later than 2:00 P.M. local time on March 16, 2015. The Districts do not accept responsibility for delays in transmittal and must have actually received at the bid proposal in advance of the time set forth above in order for the bid to be deemed received.
  
4. Each proposal must be submitted on the bid form provided with these specifications. For purposes of clarification, a dual route should be considered as either an AM route that can be covered with the same equipment as another AM a route that same day or a PM route that can be covered with the same equipment as another PM route that same day. For example, if a bus can run an 8:30 a.m. route for a particular District and then run a 9:30 a.m. route for either the same or another District, than both routes would be priced as a dual route rather than a single route.
  
5. Bids must be contained in a sealed envelope, which shall be endorsed on the outside thereof with the following information:

**PROPOSAL FOR STUDENT BUS TRANSPORTATION**

Name and Address of Bidder

6. All Bids submitted must be valid and held open for a minimum period of ninety (90) days after the date set for the bid opening.
7. The Districts reserve the right to reject any or all bids for any reason, or to waive any informalities, irregularities or defects in any proposal, should it deem to be in their best interest to do so.
8. The Districts intend to award separate contracts to the same company best able to provide the most efficient and cost effective services for all Districts.
9. All figures given for passengers, routes, or lengths of routes are based on estimates from the present operation.
10. Bidders shall not include taxes, which school districts are not subject to, in their quotation.
11. All bids shall be deemed final, conclusive and irrevocable and no bid shall be subject to correction or amendment for any error or miscalculation.
12. Bids received after the time specified in the invitation to bid will not be considered. The method of transmittal of the bid proposal is at bidder's risk of untimely receipt.
13. A bid bond for 10% of the value of the bid for the first year of the contract shall accompany all bids submitted. A bid bond shall be in the form of a certified check made payable to Niles Township High School District 219 or a bond issued by an insurance company licensed to do business in the State of Illinois with a rating of at least "A" from AM Best. However, the Districts will require, from the successful contractor, an individual performance bond covering each year of the contract in the amount of 100% of the yearly cost. The performance bond will be held by Niles Township High School District 219 on behalf of the Districts. Each bid must indicate the additional cost of such Bond. Each bid must be accompanied by a letter from an insurance company licensed in the State of Illinois with a Best Insurance Rating of at least A-10 indicating that the company will provide the specified performance bond for the bidder if desired.
14. The Districts may inquire as to the financial stability of the bidder and may request financial references.
15. The bidder shall at all times observe and comply with all laws, ordinances, regulations and codes of the federal, state, county and other local government agencies, which may in any manner affect the performance of the contract, and in particular all such laws pertaining to prevailing wage, equal opportunity, OSHA, consumer report safety act and safety. The contractor, in performing under this contract, shall not discriminate against any worker, employee or applicant, or any member of the public because of race, religion, color, age, marital status, sex, national origin, ancestry, or physical or mental disability, or engage in any other means of unlawful discrimination.

Contractor shall comply with all laws and regulations pertaining to Equal Opportunity and Fair Employment Practices including the Illinois Human Rights Act. Contractor shall not discriminate against any worker, employee, or rider or any other member of the public because of race, religion, age, color, sex, disability, marital status, sexual preference, national origin, unsatisfactory military discharge nor otherwise commit an unfair labor practice. Contractor further agrees that this article will be incorporated by Contractor in all contracts entered into with suppliers of materials and services, subcontractors and at labor organizations, furnishing skilled or unskilled labor or may perform any such labor or service.

16. Bidder must use the included Bid Proposal Forms when submitting bid, providing all information as requested. All prices must be typed or written in ink on the enclosed Bid Proposal Forms.

If mistakes are found in multiplication or addition of unit prices against total prices, the unit price shall govern for all purposes.

17. To the fullest extent permitted by law, Contractor agrees to indemnify, hold harmless and defend the Districts and their respective members, officers, employees, students, teachers, and agents against all suits, actions, legal proceedings, claims and demands, and against all damage, liabilities, judgments, lost cost, expense and attorney's fees, in any manner caused by, arising from, incident to, connected with or growing out of the provision of services under this contract.

18. No contract shall be assigned or any part of the same subcontracted without the consent of the Districts, but in no case shall such consent relieve the contractor from his obligations, or change the terms of the contract.

19. In determining the successful bidder, the Districts will consider the following:

- i. The safety and comfort of the students including demonstration of the ability of parents and students to track buses on an existing account
- ii. Bid Price
- iii. Financial stability of the bidder
- iv. Adherence to transportation specification requirements
- v. References and experience in school district transportation

20. Execution of Contract – The successful bidder will be required to execute separate transportation contracts with the Districts in substantially the same form as set forth in these Specifications.

21. The bid shall be based on the premise that neither the Cooperative / Districts shall be responsible for financing, holding title, purchasing, maintaining, repairing, or licensing of vehicles.

22. The contractor shall own all buses or vehicles placed in operation by the contractor under this contract for routes that are not paired with District 219 and shall be responsible for their maintenance and repair. The contractor will provide the maintenance and repair of buses purchased by District 219.
23. The Districts shall have first priority for the use of the buses of the contractor required to perform the services pursuant to the Agreement. The contractor may use buses for charters and bus sharing operations provided these operations have no negative effect on the Daily student transportation or the right of first priority for the use of the buses.
24. The Contractor must provide route maps for a.m. and p.m. routes. The route maps will show the routes for each District. The route maps will also show which Districts will be paired together in terms of sharing buses and sharing routes. The route maps will also provide for the specific number of buses to be committed to each route, and which Districts will be served by said bus/route/pairing. For instance, if the high school requires 22 routes for its morning transportation to school, the route map will show how many buses will serve those 22 routes, which Districts are paired with those 22 routes, and how the pairing will be applied.

## **GENERAL CONDITIONS**

### **SCOPE**

The successful Contractor shall, during the period set forth, provide and maintain the required number of school buses to transport conveniently and safely any and all students designated by the Districts to be served under the provisions of this proposal. Such transportation shall be provided for each and every day that school is in session, for each and every Districts that is a party to this contract, including to and from each and every Districts in the morning and afternoon, as well as mid-day transportation needs (including between buildings, between separate districts and cooperatives, and any other mid-day needs), and extra-curricular and activity-related transportation needs, and in accordance with bus routes and schedules agreed upon by the parties.

The Districts reserve the right to revise or change any and all routes and the number of buses required to best suit their needs at any time before or during the school year. However, any changes or revisions to routes will be made in compliance with this Contract, bearing in mind that services are shared, and changes made may affect service to other Districts that are parties to this Contract. To that end, the Districts will work together to minimize changes that could negatively impact services to the other Districts.

The Districts reserve the right to contract with other contractors for extra-curricular, charter, and other trips, in addition to the services provided by this Contract, if it meets their financial interests to do so. This would include school bus, motor coach, van, or other types of transportation needs.

The annual letter that goes home to the parents of all eligible bus riders will include the name and phone number of the contractor along with instructions that the Contractor should be called if they have questions or need assistance. In addition, the schools will often refer calls to the contractor.

All expenses related to the operation of the fleet of the Contractor shall be paid by the contractor.

The Scope of this Bid is set forth in greater detail in the proposed contract, attached to these Instructions to Bidders.

## **REFERENCES**

As indicated above, the Districts are concerned with both the financial responsibilities of the bidder and the proven ability to satisfactorily perform the contract. Written responses must be provided within the bid for the following areas of concern:

1. Indicate management experience in bus operation and transporting students. The successful bidder must have at least three (3) years of experience providing transportation services of similar size and scope to this contract.
2. Provide the names of all public school districts for whom your company currently provides transportation or has provided transportation within the previous 10 years in the following counties: Cook, DuPage, Kane, Lake, McHenry and Will. Provide the point of contact and phone number for whoever served as the district point of contact for the transportation contract. If you no longer provide transportation services for the school district, please explain why you do not. Responses are to include any contracts that you defaulted on or were cancelled by either you or the school district. Provide three letters of recommendation from current or previous clients with your bid submission.
3. Indicate all Illinois litigation your firm has been involved with during the last 10 years.

## **LOCAL OFFICE**

The Districts will provide the Contractor with a local bus office, parking lot and bus garage within Niles Township. In the event that the Districts need to construct a bus garage, the Contractor will need to provide access to their own facility for maintenance until construction of the bus garage is complete. The contractor shall staff the office with a manager and at least one lead dispatcher from 6:00 a.m. to 6:00 p.m. on school days. When buses are in use outside of this time period, a dispatcher or manager will be available by cell phone and pager within five (5) minutes to respond to concerns of the School District.

Bidders are instructed to furnish resumes including the address and telephone number of the proposed terminal manager, lead dispatcher, and head mechanic for the service of this contract. Also include the location of towing and emergency services vehicles to be used in the service of this contract. The Districts reserve the right to interview the proposed terminal manager prior to the award of contract. The proposed terminal manager must have at least five years of experience operating a terminal of similar size and scope required to service this bid.

The contractor agrees that each morning before any school buses are used for transportation; the driver shall inspect same carefully for defects, and remedy any defects before using said vehicles.

## **BUS DRIVERS**

The Contractor shall provide only bus drivers who do meet or exceed State of Illinois laws and regulations related to public school transportation and have valid licenses permitting them to serve as school bus drivers. The Contractor will provide a roster of drivers for approval by the School District prior to the first day of each school year and on a monthly basis thereafter for all new drivers, including:

1. Driver's name;
2. Driver's social security number;
3. Driver's commercial driver's license number and permit number;
4. The date on which the driver successfully passed a drug and alcohol screening; and
5. The date on which the driver was cleared by a criminal background check.

All employees of Contractor will submit to a criminal background check conducted by Districts before performing work covered by this contract. The cost of these background checks will be paid by Contractor.

All Drivers employed by the Contractor will undergo drug/alcohol testing prior to driving students.

Drivers who have not submitted to the background check and drug/alcohol testing or those who have not been cleared by a background check and drug/alcohol test may not be employed under this Contract nor shall they render services.

The parties hereby agree that the Superintendent of Schools or the Superintendent's designee may reasonably remove a particular bus driver from a particular bus route or from all buses servicing the Districts, so long as, if such removal affects a bus route pairing, all Districts affected are in agreement. In order to effectuate such removal, the Superintendent or his/her designee will make a reasonable request to the Contractor, and such Contractor will remove the bus driver within 24

hours of the request being made the Contractor agrees that this power of removal in no way is to be construed as making the bus driver or the bus company an employee, agent, servant or co-employee of the Board.

**Payment to Contractor.**

The Districts shall pay in accordance with Appendix A. Specifically, each School District party to this agreement will be charged for the services rendered to it, on a per route basis. Where /School Districts are “paired” on routes, the cost will be prorated by the number of students attributable to each School District on the route. All payments made to the Contractor must be approved by each Board of Education prior to payment; accordingly, all payments will be made within ten days of the Board of Education meeting at which the invoice is presented for payment. Invoices will be presented to the Board of Education at its meeting immediately following. If the Board of Education does not receive an invoice 15 business days in advance of its next meeting, the invoice will not be presented to the Board of Education until the following meeting.

Billing for activities, extra-curricular, field trips, intra-district trips, shuttle and special routes, and late runs shall be invoiced separately from regular morning and afternoon bus route invoices.

Invoices shall be calculated in accordance with the rates shown on the Appendix A.

Should any School District fail to make its payment in a timely fashion, such failure shall not affect the services to be rendered under this contract. The Contractor has the right to enforce collection proceedings as to any School District that fails to make its payments, while continuing to provide the transportation services called for by this Contract. Only where a majority of the School District parties fail to make payment may the Contractor discontinue services to those individual School District parties, and re-configure routes for those remaining School District parties.

The payment amounts set forth in this Contract shall remain in effect until August 1, 2018. For subsequent contract years, both the Contractor and the School Districts shall enter into negotiations at least ninety (90) days prior to the end of the current school year to mutually agree to changes in price for the various services performed under the contract. The Contractor agrees that the unit prices shall not increase by more than the increases in the Consumer Price Index for Urban Consumers (CPI-U). For the renewal year of August 1, 2018 to July 31, 2019, the CPI-U used for the maximum renewal will be CPI-U for December of 2016 that is published in January, 2017. For the renewal year of August 1, 2019 to July 31, 2020, the CPI-U used for the maximum renewal will be the CPI-U for December of 2017 that is published in January of 2018.

**FUEL ESCALATOR**

The successful bidder shall purchase and provide all necessary motor fuels for the performance of the contract. There shall be NO negotiations or changes in the bid language for the entire first year of the contract (2015-2016) for a Fuel Escalator Clause. Bidders are to use \$2 per gallon for the purposes of pricing diesel for Years 2 and 3 of the contract. In the event that diesel fuel exceeds \$2 per gallon, the contractor may assess an additional cost to the Districts upon providing invoices that indicate pricing above \$2 per gallon. Fuel escalator assessments are limited to three (3) gallons per route. District 219 will provide a propane fuel dispenser and pay for propane used for District 219 routes and routes paired with District 219.

## EQUIPMENT

- a. Contractor agrees that all equipment used during the life of this contract shall conform to all local, state and federal statutes pertaining to school bus transportation, vehicle specifications and safety, and to all relevant state and federal regulations. All buses shall be equipped with all safety equipment mandated by the federal government and/or the State of Illinois, including push out windows, rear exit doors and crossing control arms. If any bus equipment owned by the contractor fails at any time to so comply in whole or in part during the term of the contract, it shall be replaced by the contractor without expense to the Districts and without claims for adjustment per diem, or per trip, compensation. No substitution of unauthorized conveyances will be allowed, except in cases of an emergency, after authorization by the Districts.
- b. The contractor agrees that each morning before any school buses are used for transportation; the driver shall inspect same carefully for defects, and remedy any defects before using said vehicles.
- c. District 219 will purchase 55 propane fueled buses to service District 219 routes and elementary routes paired with District 219 routes. Bidders are to operate and perform maintenance on District 219 owned equipment. Bidders will insure District 219 owned equipment. Contractor will provide diesel fueled buses for routes that are not paired with District 219 (8 AM/PM routes in District 74 and 11 PM routes in District 70). Contractor will charge elementary districts using District 219 owned equipment the same price for dual routes using bidder owned equipment. The difference in the price charged for bidder owned equipment and District 219 owned equipment is to be credited to District 219.
- d. District 219 owned equipment may not be paired with other school districts outside of this contract without written approval from District 219. District 219 owns first division vehicles and provides any transportation needed with those vehicles outside of this contract. Contractor agrees that no contractor owned vehicles used to service Districts will be more than 120 months old. Contractor also agrees that at no time during this three-year (3) contract (or the potential extension) will the average age of the contractor owned vehicles used for Districts exceed eighty four (84) months. If Contractor does not have adequate equipment at the time of award of the contract, Contractor shall provide a certified statement from an authorized dealer, manufacturer, or other reliable source, showing that all necessary equipment will be supplied, and that all such equipment will be available on site for use by Contractor for performance of the contract no later than April 10, 2015. All full sized school buses will be defined as being at least 71 passengers in capacity unless otherwise defined and mutually agreed upon by Districts and Contractor.
- e. Contractor agrees to obtain in timely fashion all required inspections and to provide a copy of the inspection report for each vehicle seven (7) days prior to the first day of transportation.
- f. Contractor agrees that each driver will be equipped with a two-way communication device for emergency purposes only. Drivers are not to use the communication device for any purpose, even hands-free mode, while driving. Bidders are to describe how they will meet

this requirement. Each bus will be equipped with first-aid kit, individual seat belts, padded seats, stop-arms, school bus flashers, emergency exit, reinforced roof, safety-glass windows, and clearly visible markings as a school bus.

- g. Each bus will be equipped with first-aid kit, individual lap seat belts (for buses that service Districts 70, 71, and 74) padded seats, stop-arms, school bus flashers, emergency exit, reinforced roof, safety-glass windows, and clearly visible markings as a school bus.
- h. Each school bus will be furnished with hardware and software to fully utilize and implement GPS and a Zonar Student Transportation Tracking System or equivalent that is acceptable to the Districts. An application that tracks bus locations with a mobile device or computer will be provided to parents at no additional cost. Bidder must be currently using their proposed system in at least one school district located in Cook, DuPage, Kane, Lake, or Will County. Bidders are to describe how they will meet this requirement including where it is currently being used. Acceptance of the proposed GPS/Student Tracker system/application is at the sole discretion of the Districts. District reserve the right to a site visit to see the proposed system in operation. The proposed system must be in place and operating for Districts no later than July 1, 2015. Contractor will be assessed a penalty of \$500/day for each day that an application is not available for parents beginning with the start of the school year for District 219 in August, 2015.
- i. Contractor agrees that the maximum number of persons that Contractor will permit to occupy any vehicle is the seating capacity established by the vehicle manufacturer.
- j. Contractor agrees to make available a sufficient number and variety of vehicles equipped to provide safe and convenient transportation for all assigned students.
- k. Contractor agrees that each vehicle will be maintained in: (1) a clean, sanitary condition, and (2) good mechanical condition, including the tires. Districts reserve the right to inspect any and all buses to ensure compliance.
- l. Contractor agrees that any and all vandalism damages to Contractor's equipment shall be the responsibility of the Contractor. Districts agree(s) to cooperate with the Contractor in reasonably attempting to recoup damages from responsible parties.
- m. Contractor agrees to provide one standby vehicle for every ten active vehicles to ensure uninterrupted service in the event of mechanical breakdown of a vehicle. There must be a similar sized or larger capacity standby vehicle available. In the event the Contractor does not have sufficient standby vehicles to serve the District's needs, liquidated damages of \$1,000 per day per vehicle that was lacking will be imposed. Contractor must submit proof of this requirement at the start of each contract year and as requested by Districts. Detailed information including but not limited to the
  - 1. vehicle identification number;
  - 2. date manufactured;
  - 3. name of chassis manufacturer;
  - 4. vehicle capacity;
  - 5. body manufacturer;
  - 6. current mileage;

7. location where the vehicles will be maintained and parked when not in use during the term of the contract;

The date of the last safety inspection for each bus proposed for service of this contract must be submitted to support this requirement.

- n. Contractor agrees to equip and maintain all standby vehicles as described herein.
- o. Contractor agrees to equip all buses with route numbers that are to be displayed in the right front side window of each vehicle, in bold numerals, each numeral no less than six inches in height, or clearly visible material.
- p. Contractor agrees to equip all buses that transport students of Districts with a DVR box or similar recording mechanism in which a video camera will be mounted and operated. All recorded material shall be the sole and exclusive property of the School District, the contractor shall have no right to retain, view or otherwise make use of any tape without the written approval of the School District. Every bus used in this contract is to have a working camera installed at all times. Bidders are to describe the camera system they are proposing.  
  
Video recordings must be turned over to the requesting school in electronic format (flash drive or CD) within 24 hours of the request. Review of the video recordings and discipline for bus misconduct as revealed by the tapes shall be the responsibility of Districts.
- q. All buses shall be equipped with two-way radios that will be active at all times. These radios must have a capacity sufficient to maintain contact with the terminal at all route points and a person must be available at the terminal to respond at all times while routes are being run. An adequate number of spare radios must be available so that no bus is ever without a working radio while transporting students. The Contractor shall be able to supply 7 hand-held radios if requested for each school (as requested District 219 2, District 70 1, District 71 1 and, District 74 3) with the frequency of the buses assigned to the District for direct communication between the school and the buses. If additional radios are requested, the expense is to be paid by the District requesting the radio. Such radios shall be used in accordance with all existing FCC regulations and/or licensing requirements.
- p. Contractor shall either own and maintain sufficient tow vehicles and other emergency equipment or maintain a contact to provide sufficient and immediate emergency service to all vehicles used in the performance of this contract.
- q. In the event of a breakdown or emergency, standby buses in good working condition must be maintained and available in sufficient numbers and used in the event any buses regularly transporting students shall be inoperable. Standby buses shall meet the same standards as regular route vehicles. Daily use of spare buses will not be allowed to exceed 10% of the number of vehicles required to service the contract. A minimum of one standby vehicle for every ten (10) regular vehicles shall be available.
- r. Bidder is to describe their routing software used to determine the most efficient route structure. Routes are to be redone annually and as requested by the Districts.

## **INSURANCE**

The Contractor agrees that neither the Boards nor their members, officials, employees and agents shall in any way or manner be answerable to or suffer loss or damages, expenses, or liabilities for any acts occasioned by the Contractor, his employees, agents, or servants. The Contractor assumes all liabilities of any kind or nature arising from the operation of this Contract either by accident, negligence, theft, or otherwise.

The Contractor agrees to indemnify and hold harmless the Boards and their officials, members, employees and agents for any liability and/or claim brought against any of them as a result of Contractor's performance under this Contract.

Contractor shall procure and maintain the following minimum insurance coverages, provided that in the event the State of Illinois requires additional forms of coverage or coverage in greater amounts than those set forth herein, the Contractor shall comply with all such State requirements.

- a. Comprehensive General Liability/Contractual Personal Injury/Employer's Liability  
\$1,000,000 per occurrence/\$3,000,000 aggregate
- b. Automobile Comprehensive Liability  
\$2,000,000 combined single limit
- c. Medical Payment/all Vehicles  
\$5,000 per person each occurrence
- d. Excess Umbrella  
\$15,000,000 each occurrence, \$15,000,000 general aggregate
- e. Uninsured and Underinsured Motorist  
\$1,000,000/\$1,000,000 combined single limit
- f. Worker's Compensation insurance shall be at least the minimum of \$1,000,000 each occurrence.
- g. Insurance shall be with companies licensed to do business in Illinois with an AM Best rating of at least A 7. Insurance coverage cannot be terminated or non-renewed without thirty (30) days written notice to the School District by the insurance company. A successor company must be in place at the time of such notice.
- h. Contractor shall provide the Superintendent/Business Manager of each School District with a Certificate of Insurance no later than June 15<sup>th</sup> annually for the life of the contract. The certificate of insurance shall provide that the insurance shall not be cancelled, non-renewed or modified without the School District's receipt of written notice of said action not less than thirty (30) days prior to termination of coverage. The School District requires that the parties indemnified in the next paragraph, subparagraph "i", be named as additional insured and/or that the Contractor carry contractual liability coverage as part of a comprehensive general liability in amounts equivalent to the amounts set forth in subparagraph "a".
- i. Contractor expressly understands and agrees that any performance bond or insurance protection required by this contract, or otherwise provided by Contractor shall in no way

limit Contractor's responsibility to indemnify, hold harmless and defend the Indemnity herein provided.

- j. Within seven (7) business days following the effective date of this Contract, Contractor shall provide School District with a Performance Bond, which shall guarantee the Contractor's performance of the duties imposed upon it pursuant to the contract and indemnify School District, its Board of Education, Board members, officers, employees, and agents from any loss resulting from failure of Contractor to fully perform each or all of said duties for the enforceable duration of this Agreement.
- k. The contractor shall present all certificates of insurance to the Districts within thirty (30) days of the effective date of this contract and maintain current certificates of insurance throughout the term of this contract.
- l. All policies of insurance shall carry an endorsement to the effect that they cannot be modified, canceled or non-renewed without thirty (30) days written notice by certified or registered mail. Cancellation of any of the insurance policies required above, or the reduction of the amounts of liability insurance or medical coverage provided by such policies, shall be deemed a material breach of the contract and shall be cause for termination of the contract. Upon receipt of a notice of cancellation of any of the aforesaid insurance policies, or a reduction in the amount of coverage, the Districts shall have the option of terminating the contract or paying the premiums necessary to continue the insurance policy at the required limits of liability and deduct the payment or payments from the compensation due the contractor under the contract. No policy shall reserve or permit any right of subrogation against the Districts, their officers, employees, students, and agents thereof.
- m. Any policy under this paragraph shall cover the transportation of pupils, their parents or guardians, authorized chaperones, school district officers, faculty and employees and school nurses to and from any school or school district and in connection with an extracurricular school activity authorized by and made in compliance with school policy and Illinois State School Code.

## **OPERATION PLAN**

a. Eligible Students.

Any student who is a resident of the School District who is approved for transportation by the District administration will be transported by the Contractor.

b. No Unauthorized Persons.

No unauthorized persons shall be allowed in any vehicle while engaged in transporting students; however, the School District reserves the right to have an authorized employee ride on any vehicle on the contracted route, without prior notice to the Contractor. It is the driver's responsibility to check that each passenger has a valid School District bus pass.

c. School Calendar.

All transportation will be in accordance with the School District calendar including provisions for scheduled days off, examination schedules, testing schedules, early

dismissal days and beginning and ending times for the school day. The School District shall, by July 1 of each contract year, furnish Contractor with the School calendar and, subsequently, notice of any changes shall be furnished to the Contractor in a timely fashion.

d. Establishment of Routes.

1. The Contractor agrees to provide typed tentative routes to the School District no later than the first week of August for the transportation of students, and revised typed "final" routes are to be furnished to the School District by September 15 of each year for the regular school year. Typed routes shall include a route number, bus number, driver's name, estimated pick-up and drop-off times and corresponding locations, plus other information as may be requested by the Superintendent/Business Manager.
2. Once the Contractor's operation plan (routes) has been fully approved, it may not be changed by the Contractor without the consent of the School District. Changes may be agreed to via telephone, but must be confirmed within five (5) days in writing. The School District may require route changes based upon student population demographics.
3. The bus driver shall not deviate from the normal pickup route or from the normal pickup route time schedule except for reasons beyond his/her control; such deviations shall be reported to the Contractor who, in turn, shall promptly report the same to the District's Superintendent/Business Manager.
4. District 219 retains the right to specify the type of vehicle used on all routes. Additionally, District 219 retains the right to assign individual students to an alternate transportation service when the need arises.

## ROUTES

a. Routes Definition.

For purposes of Districts a route will be defined as use of a school bus for morning pick-up and afternoon drop-off. Buses will arrive at school in the morning between 10-20 minutes of scheduled start times. Failure to do so will result in a penalty in the amount of \$150 per day per route for routes that are 10 to 29 minutes late, and \$250 for routes that are 30 or more minutes late. The penalties will be imposed on the Contractor and deducted from the next payment from the Districts. Buses will arrive at school no later than dismissal time in the afternoon. Failure to do so will result in a penalty in the amount of \$150 per day per route routes that are 10 to 29 minutes late, and \$250 for routes that are 30 or more minutes late. The penalties will be imposed on the Contractor and deducted from the next payment from the Districts. Should the buses be late, the Contractor should notify the Superintendent or Business Manager of the reason for the delay, and the timeframe in which to expect the buses, as soon as practicable, but within 1 hour of becoming aware of the problem. For further detail on the imposition of penalties, please see Letter (f) of "General Requirements."

Should the Contractor failure to abide by established timelines more than twice per month, or fail to ever notify the Superintendent of any delays, such conduct will be deemed to be a breach of contract.

No regular school day route may extend beyond forty (40) minutes in length. These routes will be on a regular school day basis with modifications mutually agreed to on special situations as dictated by weather conditions, testing schedules and/or late start school days.

1. To/From School Routes.

Contractor shall provide bus service for each school route as designated by each School District's Superintendent/Business Manager. Within the route, stops shall be so spaced so that the distance of travel from a student's home to a bus stop shall not be greater than three (3) blocks. Routes should be established so that no student need cross an arterial street or main thoroughfare to either reach a bus stop or reach their home after being dropped off. Any pairing of routes should be for the purpose of better serving all Districts and accommodating time frames; any pairing of routes requires the approval of District 219.

2. Extra Curricular Sports Buses at the Conclusion of the Regular School Day.

Niles Township High School District 219 needs to have available on a regular daily basis three (3) school buses at each high school for the purpose of transporting sports teams to different events. These buses need to be available at dismissal time at each school, ready to leave with the sports team to wherever the competition is being held. These buses need to be available on a daily basis. On days that the buses are not going to be utilized, District 219 will notify the Contractor at least 48 hours in advance and the District will not be charged. Billing for these trips will be as delineated in Appendix A. Bus drivers are expected to remain at the site of the sport competition for the duration of the contest and make the sponsor or coach of the team aware of how to contact them.

The other School District parties to this contract may need regular extra-curricular transportation, as described in greater detail on the list of proposed transportation needs, attached hereto as Appendix B.

3. After School Activity Routes.

Niles Township High School District 219 requires five buses at each school every school day. These buses will leave the schools with students involved in after school activities at approximately 5:00 p.m. and 6:00 p.m.

On the days that the School District notifies the Contractor, at least one week in advance that the routes will not be needed, no charge will be assessed.

The other School District parties to this contract may need regular extra-curricular transportation, as described in greater detail on Appendix B.

4. Seating Capacity.

- i. For school routes, seating may be at two (2) students per standard seat. "Standard seat" is defined as the common size of a seat on a full-sized school bus, as defined in the "Instructions to Bidders."
- ii. For school field trips and extracurricular trips, seating shall be at not more than two (2) students per standard seat.

b. Ridership Audit.

Contractor shall submit to the School District, on an "as requested" basis, a Ridership Report covering one week for each To and From school route to each school building. This headcount may also be required for the after school activity routes. The report shall indicate the seating capacity (at 2 per seat) of the vehicle serving the route, the number of students entering the vehicle at each pick-up point for each route. The Contractor shall make suggestions on a monthly basis as to how to attain route efficiencies or better serve the School District. The purpose of Ridership Audits is to ensure that routes are efficiently loaded and to provide data on which to base decisions regarding route removal, combination and expansion.

c. Route Times.

The starting time for incoming routes shall be set to allow the bus to arrive at the school not less than ten minutes or more than 20 minutes prior to the designated start time of the school. Outgoing routes shall be scheduled so that the bus arrives at the school five minutes prior to dismissal.

District 219's start time will be contingent upon the start/dismissal time negotiated in its collective bargaining agreement with its teachers.

Student start times for all other cooperatives/districts are attached hereto as Appendix D. Should any district vary its student start/dismissal time from that listed on Appendix D, it must do so in cooperation with and agreement by all other parties to this Agreement. Should it change its student start/dismissal time without obtaining the agreement of the other parties, it will be liable for any and all damages incurred.

d. Field Trips – Extra Curricular Trips.

The School Districts shall schedule at least one (1) faculty member or other approved adult supervisor on each Field Trip or Extra Curricular bus.

1. Scheduling: Field trips shall be scheduled by the school requiring the trip at least ten (10) days in advance of the field trip. Generally, field trips scheduled in this manner shall be billed as delineated Appendix A. Field trips shall be scheduled through each School District's form "Vehicle Use Trip Requisition". This form shall be completed by Contractor and returned to the ordering school upon completion of the trip. Both parties will endeavor to simplify this process as time permits.
2. Cancellations: Field trips may be canceled by the ordering school at no charge to the school when the cancellation occurs not less than three (3) days prior to the field trip.

3. Field Trips Schedules Less than Five (5) School Days in Advance: Contractor shall not be required to provide a driver at straight time. However, where such a trip is expected to require overtime for drivers, Contractor shall inform the ordering school upon receipt of the Vehicle Use Trip Requisition. The school shall then have the option of accepting the field trip at the overtime rate or canceling the trip.

e. Individual District Regular Routes.

Signs are to be placed on all individual school buses identifying the school and route. Please see Appendix C for information related to the regular routes.

f. Routes are paired and to bid as follows:

Niles North A.M. is paired with District 70 A.M. (11 routes).

**Niles North P.M. is not to be paired.**

Niles West A.M. is paired with District 71 (5), and District 74 Rutledge (8) routes (13 routes total).

Niles West P.M. is paired with District 71 (5) and District 74 Todd Hall routes (8) (13 routes total).

District 74 A.M. Lincoln Hall is paired with Todd Hall 8 double run routes total.

District 74 PM Routes Rutledge Hall is paired with Lincoln Hall 8 double run routes total

- g. Niles North and Niles West have some routes that are repeated. Actual routes were provided at the pre-bid meeting. For example, Niles North morning routes 15 and 19 currently use 2 buses. Contractor will separate these extra buses into separate routes at the start of the contract. In the afternoon, Niles North has 2 "E", 3 "K",
- h. Bidders are to bid on 176 days of service. This is the minimum guarantee. Each school district sets their own calendar and reserves the right to add additional days of service beyond 176.
- i. District 219 operates 30 days of summer school. Starting in the Summer of 2016, programming will offered at both high schools. Regular education routes will be similar to the current year; however, the actual number of routes will be less.
- j. The District 219 6 dedicated daily Athletic buses are to be billed at an hourly rate. These routes conflict with PM routes. Bidders are to provide an hourly rate for these trips. For the purposes of the bid tabulation, 6 routes per day, 170days, 5 hours per trip is the factor to calculate estimated annual costs. The minimum guarantee for each athletic route is 3 hours. Bidders are reminded that these routes can be cancelled with one week's notice.
- k. On the bid form, District 219 is not guaranteeing 3 field trips per day. Approximately \$151,000 was spent on field trips last year. This line item is to solicit pricing on an hourly rate per trip (3 hour minimum) basis and each trip is to be billed individually.
- l. Bidders are to provide a surcharge rate per mile for trips that are over 50 miles one-way.

- m. First Division Vehicles are operated by District 219. Bidders will not be providing this service. District 219 reserves the right to perform all service not expressly guaranteed as minimum service level on the bid form.

### **STUDENT BEHAVIOR**

- a. The School District, through its building principals, may from time to time, issue instructions governing the behavior of students. The Contractor's drivers shall, to the best of their abilities, follow such instructions at all times. Such instructions shall also include procedures for reporting misconduct.
- b. The Contractor will report each incident of student misconduct immediately by phone or in person to the Dean of Students of the receiving school, and follow up with a written report.
- c. The Contractor will not permit smoking, the consumption of alcohol or the consumption of non-prescription drugs controlled substances, and/or engage in immoral activities on the bus.
- d. The Contractor shall promptly notify the Dean of Students whenever any student is recommended for suspension from transportation. The Dean of Students shall make a final determination of suspension from transportation.
- e. The Contractor's drivers shall not administer physical punishment to any student on the bus.
- f. No vehicle shall transport more than five (5) students in wheelchairs in each bus route, unless prior District approval is obtained.
- g. The contractor shall be responsible for informing all parents of scheduled home pickup and return times, and shall maintain a consistent schedule in this regard.
- h. General Education students are picked up and dropped off at District agreed upon locations.
- i. No unauthorized persons shall be allowed in any vehicle while engaged in transporting students; however, the Districts reserve the right to have an authorized representative ride on any bus, on any contracted route, without prior notice to the carrier. Drivers will not be allowed to bring their children on their runs.
- j. No student will be transferred from one vehicle to another vehicle while en-route to or from school without the expressed prior approval of the District.
- k. The Contractor understands that some of the students to be transported suffer from behavioral disorders and may present discipline problems. The School Districts have statutory obligations to provide transportation for all students, regardless of their behavior. The Contractor will undertake to transport all students taking into consideration that some of the students may not meet the expectations of acceptable conduct for the typical student. No student can be refused transportation due to discipline or conduct problems. If a student exhibits inappropriate behavior, this conduct shall be brought to the attention of the appropriate school official who shall determine what (if any) disciplinary action is required. Severe conduct problems may require the assistance of an

aide for the route involved, and any such requirement may be suggested by the Contractor, subject to the prior written approval of the School District.

## **SAFETY PROGRAM**

- a. The Contractor shall establish and maintain a plan for safety, including, but not limited to:
  1. Regularly scheduled in-service meetings for drivers and aides to include, but not limited to:
    - a) Defensive driver training.
    - b) Blood-borne pathogens training.
    - c) Conflict resolution training.
  2. Daily vehicle inspections.
  3. Driver supervisor to enforce good driving practices with respect to safety, mechanical operation, adherence to time schedules, and conformity with applicable laws and regulations.
  4. Two written bus driver evaluations per year by the bus manager with input from appropriate school administrators. Upon request, the written evaluations of the drivers shall be provided to the Superintendent or his designee.
  5. All driver applicants must meet acceptability requirements as indicated in 625ILCS 5/6-106.1. All drivers must participate in both classroom and on-the-road training programs devoted to safety, proper bus operation, rules and regulations, and first aid.
  6. All drivers must participate in a defensive driving course as certified by the National Safety Council or equivalent training program approved by the Cooperative.
  7. All drivers must be reviewed after thirty (30) days of employment and at least annually thereafter and must annually be given a review course on rules, regulations, safety and first aid.
- b. The Contractor shall ensure that drivers and dispatchers understand appropriate emergency procedures through regular in-service training meetings.
  1. The contractor will follow Districts' procedures for emergency cancellation of transportation in those cases where weather conditions may preclude the movement of buses. There shall not be a charge for services if a regular school day is cancelled.
  2. When extreme weather conditions or other emergencies require the early dismissal of school during the regular school day, the contractor shall transport students home from school. Specific arrangements for pickups and arrival times shall be coordinated between Districts and contractor.
- c. The Contractor shall prohibit any driver from driving a school bus while smoking or under influence of alcohol, non-prescription drugs or controlled substances. Every effort must be made to insure that drivers are in good health, and adequate provision must be made for substitute drivers when regular drivers are absent.
- d. The Contractor shall require all drivers not to begin their routes or not to move forward until all students are seated within the bus.

- e. The abstract of the driving record of each driver shall be obtained from the Secretary of State annually, subject to review if requested. Each driver shall undergo a drug test as part of his or her physical exam for each initial permit and each permit renewal. A positive test result shall disqualify a driver from providing service under this contract. Post accident testing is required. All drug and alcohol testing procedures shall be in strict compliance with State and Federal regulations.
- f. The Contractor shall perform criminal background checks for all drivers, as well as any other employees having contact with students. The contractor shall bear the sole responsibility of all costs incurred in providing qualified drivers or other personnel, such costs including but not limited to training, safety seminars, physical examinations, criminal background checks, drug tests, license and permit fees, recruitment expenses, salaries, fringe benefits and other conditions of employment. The Contractor shall provide copies of all such background checks. The Districts shall have the right to request that any employee of the Contractor be removed from performing any services for any reason. Following such a request, the Contractor shall immediately remove and replace the employee in question.
- g. All drivers shall maintain a neat and clean appearance at all times. They shall also display identification as employees of the contractor.

**GENERAL REQUIREMENTS**

- a. All laws, rules, regulations, ordinances of the federal, state, county or local government or orders heretofore or hereafter made or issued by the Superintendent of the State Board of Education or by the Superintendent of the Educational Service Region, Cook County, are to be made a part of this Contract as fully as though the same were herein set forth.
- b. This contract is for furnishing student transportation. In performing this contract, the Contractor is an independent contractor and not an officer, member, agent or employee of the School District.
- c. The Contractor shall assist the Board in completing all reports as may from time to time be required by the Board of Education, the Superintendent of the Illinois State Board of Education or any other entity or agency properly exercising jurisdiction over the subject matter of this Contract.
- d. In the case of all emergencies or accidents involving a vehicle, the District's Transportation Supervisor will be contacted immediately and informed of the situation. This contact shall first be by phone and then by written report. The severity of the situation will not be a factor in whether or not the Transportation Supervisor is notified. The Contractor is responsible in the event of any accident to follow established procedures, including the prompt obtaining of any necessary medical assistance and the notification of the responsible police department.
- e. This contract shall be governed and construed in accordance with the laws of the State of Illinois. If any provision hereof shall be held to contravene any applicable law, such provision shall be deemed reformed to the extent of conforming to said law, and in all other respects the terms hereof shall remain in full force and effect. Contractor shall comply with all

applicable laws, regulations and rules promulgated by the Federal, State, County, Municipal and/or other governmental unit or regulatory body now in effect or which may be in effect during the performance of the contract. Included within the scope of the laws, regulations and rules referred to in this paragraph, but in no way to operate as a limitation, are all forms of traffic regulations, public utility and Intrastate Commerce Commission regulations, Worker’s Compensation Laws, the Social Security Act, Occupational Safety and Health Act, the Consumer Product Safety Act, the Illinois School Code and the Illinois Motor Vehicle Code.

Additionally, the Contractor shall comply with all laws and regulations pertaining to Equal Opportunity and Fair Employment Practices including the Illinois Human Rights Act. Contractor shall not discriminate against any worker, employee, or applicant, or any other member of the public because of race, religion, color, age, sex, handicap, marital status, sexual preference, national origin, or unsatisfactory military discharge, nor otherwise commit an unfair labor practice. Contractor further agrees that this article will be incorporated by Contractor in all contracts entered into with by suppliers of materials and services, subcontractors and at labor organizations, furnishing skilled, unskilled, or craft union skilled labor, or may perform any such labor or service in connection with this contract.

Further, Contractor certifies that it has adopted and implemented a written sexual harassment policy in full compliance with PA 87-1257 and Section 2-105A(4) of the Illinois Human Rights Act, 775 ILCS 5/2-105A(4), and in case of the Contractor having 25 or more employees, a drug-free workplace policy and practice in full compliance with Section 3 of the Illinois Drug-Free Workplace Act, 301 ILCS 580/3.

Finally, Contractor certifies that it is not ineligible for award of this contract by reason of debarment for a violation of any of the above-referenced laws and regulations and acknowledges that any breach of the foregoing provisions shall constitute a breach of this contract.

- f. Noncompliance is defined as, but not limited to, the failure to transport students on a bus route or routes as contracted or as requested in accordance with the terms of this contract, or the failure to make changes to routes as specified and directed by the Superintendent/Business Manager in accordance with the terms of this contract.

Should Districts find the Contractor in noncompliance with the provisions of its contract on a bus route or series of routes, the School District will be entitled to impose the following damages.

<b><u>Incident</u></b>	<b><u>Damages</u></b>
No service on any to or from regularly scheduled route	Daily rate per route x 300%
Late pick-up (10 minutes or more as defined on approved route sheet) at a school	10-29 minutes \$150 per day per route 30 or more minutes \$250 per day per route

Late drop-off (10 minutes or more as defined on approved route sheet) at a school	10-29 minutes \$150 per day per route 30 or more minutes \$250 per day per route
No shows for extra-curricular and sport routes	\$400 per occurrence
Tardiness for sports and extra-curricular route (10 minutes later than stipulated time)	10-29 minutes \$150 per day per route 30 or more minutes \$250 per day per route
Failure to provide a properly licensed and permitted driver for a to/from route	\$200 per day per route
Changes in a bus route(s) without notification	\$100 per day per occurrence
If the faculty sponsor of a trip must make alternate transportation arrangements because of Contractor actions	\$400 per occurrence plus expenses
Failure to provide bus video within 24 hours of request	\$150 per occurrence

The noncompliance damages for late pick-up and drop-off shall not apply during weather involving hazardous driving conditions.

A penalty shall be deducted from the first invoice following the noncompliance. The failure of School District to assess or collect any penalty under this Section shall not be considered a waiver of the School District’s right to assess or collect that penalty in the future or a waiver with respect to any future violation committed by the Contractor.

- g. The Contractor agrees not to reassign or sell any rights to this Contract to another party or parties.
- h. The officers of the contracting bus company who sign this Contract covenant that the Contractor is duly authorized to conduct business in the State of Illinois and that they have authority to execute and deliver the Contract by and on behalf of the contracting bus company.
- i. All payments by the Board to the Contractor in connection with the Contract shall be made pursuant to the Local Government Prompt Payment Act unless otherwise expressly stated in the Contract Documents. Payments shall be made to the Contractor for daily to/from routes, after school activity routes, and extra-curricular sports routes based on routes and unit prices as bid or as subsequently amended per the inflation clause. These payments shall be made monthly September through June. A final reconciliation payment will be made not later than July 15th of each year. Payments for all other services under this contract, i.e., field trips, late routes, etc., shall be made monthly in arrears, upon submission by the Contractor of individual invoices covering the services provided.

- j. The contractor shall have a manager in charge of performance of this contract and furnish the name and address of such manager and the statement that such manager shall have complete authority with respect to all matters relating to the performance of this contract. This shall include matters relating to personnel and the changes and substitutions thereof, adherence to and changes in schedules and responsibility for keeping of records required under the terms of the contract. The manager should have a minimum of five (5) years experience in management of pupil transportation services. The contractor shall make every effort to maintain the same route supervisor for the school year.
- k. Current bussing school locations and current route information are highlighted in the attached Summary of Experience. Totals are approximations only and are in no way intended to be final figures. As many routes as possible should be designed to run two or more programs back to back whenever possible in order to minimize costs to said districts.

**A. Termination of Contract.**

- a. The School District may terminate this contract at any time during the contract period by providing written notice of said termination to the Contractor at least thirty days prior to the termination date.
- b. The sole right to determine whether or not the quality of service during the term of this contract is maintained, at the standard previously established, is the discretion of the Districts. The parties further agree that any failure to meet this standard of services constitutes a breach of this contract and constitutes sufficient reason to terminate the contract as set forth below.
- c. If, at any time, the Contractor fails to comply with the terms of this Agreement, or does not fully perform and strictly adhere to any of the terms hereof required to be performed or adhered to by Contractor, or its drivers, or employees, the Board may, in addition to other remedies and/or penalties provided for herein, and in its sole discretion, terminate this Agreement as provided herein, with prejudice.
- d. In the event that the Board determines that the Contractor has failed to comply with, fully perform, or strictly adhere to this Agreement, the Board may send written notice at least thirty (30) days in advance to the Contractor indicating the intention of the Board to declare the Contractor in default. In such notice, the Board will state in what respect the Contractor has failed to comply with the terms of this Agreement, and will state a date certain upon which the Agreement will terminate unless the Contractor, prior to such date, cures the defect to the satisfaction of the Board. If, prior to the date of termination stated in the notice as aforesaid, the Board notifies the Contractor that the defect has been cured, this Agreement will not terminate on the date stated in the notice but will be deemed to have remained in effect as of the date such notice was given. In the event that the Board does not so notify the Contractor that the defect has been cured as aforesaid, this Agreement is terminated without further action by the Board on the date of termination stated in the notice and in such event, the bond posted by the Contractor shall be paid to the Board of Education without further proceedings or notice.

- e. The date of termination stated in the notice of intent to declare the Contractor in default, as provided in "A" above, may not be sooner than 30 calendar days following the date of such notice unless there is a complete failure by the Contractor to provide the services required by this contract, in which event the date of termination may be 5 calendar days following the date of such notice.
- f. The right of the Board to terminate this Agreement as provided in Paragraph O, is cumulative with all other rights of the Board contained herein. The Board's failure to send a Notice of Default to the Contractor shall not be deemed a waiver of the Board's right to terminate the operating Agreement under this Paragraph O.

**Notices.**

All notices required under this Agreement shall be sent in writing by regular and certified mail to the following addresses:

To the Board:

Board of Education  
ADDRESS  
CITY, STATE and ZIP

To the Contractor:

CONTRACTOR, Inc.  
ADDRESS  
CITY, STATE and ZIP

If further assistance is required in the preparation of this proposal, please contact Mr. Eric Trimberger, Assistant Superintendent for Business/CSBO, at [eritri@d219.org](mailto:eritri@d219.org).

---

Name of Bidder (please print)

---

Bid Submitted by

---

Address

---

Title

---

Phone number

---

Date

**CERTIFICATION REGARDING GENERAL UNDERSTANDING AND ACCEPTANCE OF BID CONDITIONS**

I have read and understand the information included in this Student Bus Transportation bid packet and have bid accordingly. I have provided all necessary information and have checked all computations. The proposal has been submitted with each space properly completed. I understand that no claim for relief because of errors or omissions in the bidding will be considered, and bidders will be held strictly to the proposals as submitted.

Name of Bidder (please print)	Bid Submitted by (signature)
Address	Title
Phone number	Date

The Contractor listed above is:

Minority owned Business:	Yes _____	No _____
Female owned Business:	Yes _____	No _____
Business owned by persons with disabilities:	Yes _____	No _____
Locally owned Business:	Yes _____	No _____

IN WITNESS WHEREOF, the parties hereto, through their duly authorized officers or representatives, have executed this Agreement as of the Effective Date set forth above.



**CERTIFICATE OF ELIGIBILITY TO BID**

\_\_\_\_\_ (contractor), pursuant to section 33E-11 of the Illinois Criminal Code of 1961 as amended, hereby certifies that neither (he, she, it) nor any of (his, her, its) partners, officers, or owners of (his, her, its) business has been convicted in the past five (5) years of the offense of bid-rigging under section 33E-3 of the Illinois Criminal Code of 1961 as amended and that neither (he, she, it) nor any of (his, her, its) partners, officers or owners of (his, her, its) business has ever been convicted of the offense of bid-rotating under section 33E-4 of the Illinois Criminal Code of 1961 as amended.

Date: \_\_\_\_\_

\_\_\_\_\_ Name of Contractor/Company

\_\_\_\_\_ Street Address

\_\_\_\_\_ City, State, Zip Code

\_\_\_\_\_ Title of Officer

\_\_\_\_\_ Name of Officer (Typed)

\_\_\_\_\_ Signature of Officer

**Criminal Background Check Certification**

Contractor hereby represents, warrants and certifies that in accordance with Section 10-21.9 of the *Illinois School Code* efforts have been made to screen applicants and to perform background checks to ensure that Contractor’s employees who will serve the District under this Contract have no prior criminal record that would render said persons as prohibited from working in a school setting, e.g., child molestation, pornography, etc. Contractor will also be and remain in compliance with current and future local, state, and federal laws and regulations regarding this matter.

Contractor further agrees that it shall not employ any person, including but not limited to school bus drivers and other transportation employees, who have or may have direct, daily contact with the pupils of any school in the District, and for whom a criminal background investigation has not been conducted pursuant hereto, and further represents and agrees that all applicants for any such employment shall furnish with their applications the written “Authorization of Criminal Background Information from, which is attached to the Contract Documents as Attachment H, authorizing the Board of Education to request a criminal background investigation of said applicant pursuant to Section 10-21.9 of the *Illinois School Code* and to receive criminal history record information pursuant thereto to determine if the applicant has been convicted of committing or attempting to commit any of the criminal or drug offenses enumerated in Section 10-21.9. Contractor further agrees to submit with said authorization payment for any costs and expenses associated with the criminal background investigation.

Carrier further represents, warrants, and certifies that no applicant for employment with respect to whom the criminal investigation reveals any conviction for committing and/or attempting to commit any of the enumerated offenses set forth in Section 10-21.9 of the *Illinois School Code*, shall be employed thereby in any position that involves or may involve contact with the students of the School District.

This certification is executed on the date hereinafter indicated by the designated Contractor by its duly authorized officer.

\_\_\_\_\_  
Name of Contractor

Date: \_\_\_\_\_

\_\_\_\_\_  
Contractor’s Signature

\_\_\_\_\_  
Name and Title

**NON-COLLUSION AFFIDAVIT**

The undersigned bidder or agent, being truly sworn, on oath that he has not, nor has any other member, representative or agent of the firm, company, corporation or partnership represented by him, entered into any combination, collusion or agreement with any person relative to the price to be bid by anyone at such letting, not to prevent any person from bidding nor to induce anyone to refrain from bidding, and that bid is made without reference to any other bid and without any agreement, understanding or combination with any other person in reference to such bidding.

He further says that no person or persons, firms, or corporations has, have, or will receive directly or indirectly, any rebate, fee, gift, commission or thing of value on account of such sale.

\_\_\_\_\_  
Firm or Corporation Official

On behalf of:

\_\_\_\_\_  
Firm or Corporation

Subscribed and sworn to before me this \_\_\_\_\_ day of \_\_\_\_\_ (month/year).

My commission expires:

Date: \_\_\_\_\_

Signature: \_\_\_\_\_

**OWNER'S CONTRACTUAL LIABILITY PROTECTION**

The contractor shall at all times save the School District and the Board of Education harmless against loss from Liability imposed by law upon them for damages on account of bodily injuries or death suffered or alleged to have been suffered, as a result of any accident occurring from or by reason of, or in course of operations under contract, whether occurring by reason of acts or omissions of Contractor or any Subcontractor, or both.

The Contractor shall at all times save the School District and the Board of Education harmless against loss from Liability imposed by law upon them for damages on account of injuries to property suffered or alleged to have been suffered as a result of any accident occurring from reason of or in course of operations under Contract, whether occurring by reason of acts or omissions or Contractor of any Subcontractor, or both, insuring School District and Board of Education against loss from Liability imposed by law upon them for damages on account of such injuries or loss.

\_\_\_\_\_  
Firm or Corporation Official

On behalf of:

\_\_\_\_\_  
Firm or Corporation

Subscribed and sworn to before me this \_\_\_\_\_ day of \_\_\_\_\_ (month/year).

My commission expires:

Date: \_\_\_\_\_ Signature: \_\_\_\_\_

**Statement of Non- Discrimination**

As part of my proposal on a contract to provide transportation, I certify:

1. That in the hiring of employees for the performance of work under this Contract or any subcontract, as Contractor, or any persons acting on the Contractor’s behalf, shall not, by reason of race, creed, color, national origin, age, sexual orientation, marital status, citizenship status, arrest record, being a victim of domestic or sexual violence, mental or physical handicap or disability, military status or unfavorable discharge from military service, discriminate against any citizen of the State in the employment of labor or workers who are qualified and available to perform the work to which the employment relates.
  
2. That no contractor, subcontractor, nor a person acting on the contractor’s behalf shall not, in any manner, discriminate against or intimidate any employee hired for the performance of work under this Contract on account of race, creed, color, national origin, age, sex, religion, sexual orientation, marital status, citizenship status, arrest record, being a victim of domestic violence, mental or physical handicap or disability or unfavorable discharge from military service.
  
3. For the performance of the Contract, the Contractor shall agree as follows: That all contractors or subcontractors will comply with all the state laws regarding nondiscrimination. The Contractor will take affirmative action to ensure that applicants are employed, and that employees are treated during employment, without regard to their race, creed, color, national origin, age, sex, religion, sexual orientation, marital status, citizenship status, arrest record, being a victim of domestic or sexual violence, mental or physical handicap, or disability, military status or unfavorable discharge from military service.

Furthermore, it is understood that the undersigned has been given the authority to represent the company herein listed below.

\_\_\_\_\_  
Firm or Corporation Official

On behalf of:

\_\_\_\_\_  
Firm or Corporation

Subscribed and sworn to before me on this \_\_\_\_\_ day of \_\_\_\_\_ (month/year)  
My commission expires:

Date: \_\_\_\_\_

Signature: \_\_\_\_\_

**CERTIFICATE REGARDING EQUAL EMPLOYMENT OPPORTUNITY**

The undersigned hereby certifies that the Bidder is in compliance with the Equal Employment Opportunity Act and the Illinois Fair Employment Practices Act as stated under Compliance with Legislation in Instructions to Bidder.

---

Name of Bidder (Please Print)

---

Submitted by (Signature)

---

Title

## TRANSPORTATION CONTRACT

**AGREEMENT made the \_\_\_\_ day of \_\_\_\_, 2015, between  
\_\_\_\_ SCHOOL DISTRICT  
(hereinafter referred to as the "District") and CONTRACTOR, INC. (hereinafter referred to  
as the "Contractor").**

### **Term of Contract.**

The Contractor, for and in consideration of the payments to be made as hereinafter set forth in the Cost Schedule attached hereto as Appendix A, hereby agrees to transport students that the District must transport by law and students that have independently agreed to pay for transportation to and from the schools of the Districts and all special routes as defined herein as well as all students requiring transportation for extracurricular activities including activity trips, field trips, and transportation for such events as are required by the Board or its authorized agent from August 1, 2015, through July 31, 2018. The term of this contract may be extended at the option of the District for two (2) additional one (1) year periods. Notice of the extension of the contract shall be provided to the Contractor in writing not later than March 31<sup>st</sup> of the year of termination.

### **Local Office and On-Duty Dispatcher/Manager.**

The Contractor shall maintain a local bus office parking lot and bus garage within Niles Township or within a ten-mile radius of the intersection of Skokie Boulevard and Oakton Street in Skokie, Illinois. The local office shall be staffed with a manager and at least one dispatcher from 6:00 a.m. to 6:00 p.m. on school days. When buses are in use outside of this time period, a dispatcher or manager will be available by cell phone and pager within five (5) minutes to respond to concerns of the School District.

Indicate the location where the buses will be housed and maintained. The facility must house all functions, including storage of buses, maintenance and dispatch operations of the contractor.

### **Contract Documents.**

The "Contract Documents" shall consist of this Agreement, the Bid Specifications (including but not limited to the Instructions to Bidders, References, all requisite certifications, bid and performance bonds, insurance, and bid form), the Cost Schedule attached as Appendix A. Appendix C and D to this document are merely to assist in the bidding process, and shall not be deemed binding contractual requirements. The Bid Specifications and the Cost Schedule are hereby incorporated into this Agreement as though they were fully set forth herein and shall have the same force and effect as any other provision in this Agreement. In the event of a conflict between the Bid Specifications and this Agreement, the Bid Specifications shall prevail. Upon award of this Contract, the Bid Specifications will be attached hereto as Appendix B, and the Cost Schedule is attached hereto as Appendix A. In attaching, it is the intent of the parties that both appendices are hereby made a part of this Agreement.

### **Hold Harmless Agreement**

The Contractor agrees to indemnify, hold harmless, and defend the Boards of Education of Districts, its officials, employees and agents from and against all suits, actions, legal proceedings, claims, demands, damages, losses, and expenses, including attorneys' fees, in any manner caused by, arising from, incident to, connected with or growing out of the operation of school buses and other vehicles used to transport students under this Contract, in accordance with the liability insurance policies procured by Contractor under this Agreement. Said policies are subject to review and approval by the District.

**Document Supremacy**

In the event any term or provision of one Contract Document conflicts with a term or provision of another, the term or provision of the Contract shall prevail over all other documents. The terms and provisions of the bid specifications shall prevail over the bid sheet.

**Compensation**

Contractor shall provide all services as awarded by District and shall be compensated according to the terms of the bid specifications and the Attachments in the amounts listed in the bid sheet submitted by Contractor.

**Complete Understanding**

This Agreement sets forth all of the promises, agreements, conditions, and understandings between the parties relative to the subject matter hereof, and no other promises, agreements, or understandings, whether oral or written, expressed or implied, exist between the parties.

**Amendments**

No subsequent alteration, amendment, change, addition, deletion, or modification to this Agreement shall be binding upon the parties hereto unless reduced to writing and duly authorized and signed by each of them.

WHEREAS, the Parties have duly executed and entered into this Contract as of the day and year set forth above.

BOARD OF EDUCATION

CONTRACTOR, INC.

By: \_\_\_\_\_  
President, Board of Education

By \_\_\_\_\_  
Authorized Representative

Attest: \_\_\_\_\_  
Secretary, Board of Education

Attest: \_\_\_\_\_

**APPENDIX A – INSERT COMPLETED BID SHEETS**

**APPENDIX B – BID SPECIFICATIONS**

**To be inserted as part of Contract post-bid**

**APPENDIX C**

**TRANSPORTATION REQUIREMENTS**

District boundaries and current route maps, for purposes of assisting in preparing bid, are attached to this Appendix as Exhibit A.

**NILES TOWNSHIP HIGH SCHOOL DISTRICT 219**

The following information depicts the regular school day transportation needs for Niles Township High School District 219.

Niles West High School

AM Routes = 25

PM Routes = 22

After School Activity Routes = 4

After School Athletic Routes = 3

Niles North High School

AM Routes = 24

PM Routes = 17

After School Activity Routes = 4

After School Athletic Routes = 3

**MORTON GROVE SCHOOL DISTRICT 70**

Parkview School

AM Routes = 11

PM Routes = 11

Mid Day Routes = 1 (AM and PM – the same bus loops)

**5 Early release days 3 at 1:30, 2 at 11:45**

**NILES SCHOOL DISTRICT 71**

Clarence Culver School

AM Routes = 5

PM Routes @ 3:00 PM = 5

Late Activity Route = 1 M-Th 4:00

**LINCOLNWOOD SCHOOL DISTRICT 74**

Lincoln Hall, Rutledge Hall and Todd hall all on one campus.

AM Routes = Lincoln Hall is paired with Todd Hall 8 double run routes total,

Rutledge Hall 8 routes

PM Routes = Rutledge Hall is paired with Lincoln Hall 8 double run routes total

Todd Hall 8 routes

Todd Hall has 2 Mid-Day routes at 11:10

Early Activity-4 Routes arrive at 7:20

Late Activity-2 Routes leave at 4:20

**ADDITIONAL INFORMATION**

**ACTUAL EXPENSES AND BUDGETS  
2013-2014**

DISTRICT	REGULAR ED	SPECIAL ED	EXTRA	SUMMER
219	1,875,412	972,796	433,365	81,029
70	233,119		30,259	
71	100,234		24,751	
74	282,874		52,246	

**2014-2015 BUDGET**

DISTRICT	REGULAR ED	SPECIAL ED	EXTRA	SUMMER
219	1,760,000	1,000,000	427,000	122,310
70	275,000		30,000	
71	110,000		36,000	
74	610,000		70,000	

**MILES**

**2013-2014**

DISTRICT	REGULAR ED	SPECIAL ED		
219	76,308	226,192		
70	9,328			
71	10,912			
74	21,120			

**APPENDIX D**

**BELL TIMES**

**NILES TOWNSHIP HIGH SCHOOL DISTRICT 219**

The following information depicts the regular school day transportation needs for Niles Township High School District 219.

Niles West High School

8:10 AM – 3:23 PM

Niles North High School

8:10 AM – 3:23 PM

**Late Start/Early Dismissal are what times??? Activity Bus???**

**MORTON GROVE SCHOOL DISTRICT 70**

Parkview School 8:20 AM – 3:20 PM busses arrive by 8:15

**NILES SCHOOL DISTRICT 71**

Clarence Culver School

8:00 AM – 3:00 PM

Activity Bus M- TH @ 4:00 PM

**LINCOLNWOOD SCHOOL DISTRICT 74**

Todd Hall 8:25 AM – 2:55 PM, AM PK 8:25-11:10, PM PK 12:10-2:55 PM

Rutledge Hall 8:00 AM – 2:45

Lincoln Hall 8:00 AM – 3:20 PM



# CERTIFICATE OF LIABILITY INSURANCE

DATE(MM/DD/YYYY)  
03/28/2024

THIS CERTIFICATE IS ISSUED AS A MATTER OF INFORMATION ONLY AND CONFERS NO RIGHTS UPON THE CERTIFICATE HOLDER. THIS CERTIFICATE DOES NOT AFFIRMATIVELY OR NEGATIVELY AMEND, EXTEND OR ALTER THE COVERAGE AFFORDED BY THE POLICIES BELOW. THIS CERTIFICATE OF INSURANCE DOES NOT CONSTITUTE A CONTRACT BETWEEN THE ISSUING INSURER(S), AUTHORIZED REPRESENTATIVE OR PRODUCER, AND THE CERTIFICATE HOLDER.

**IMPORTANT:** If the certificate holder is an ADDITIONAL INSURED, the policy(ies) must have ADDITIONAL INSURED provisions or be endorsed. If SUBROGATION IS WAIVED, subject to the terms and conditions of the policy, certain policies may require an endorsement. A statement on this certificate does not confer rights to the certificate holder in lieu of such endorsement(s).

<b>PRODUCER</b> Aon Risk Services Central, Inc. Chicago IL Office 200 East Randolph Chicago IL 60601 USA	<b>CONTACT NAME:</b> PHONE (A/C. No. Ext): (866) 283-7122      FAX (A/C. No.): (800) 363-0105		
	<b>E-MAIL ADDRESS:</b>		
<b>INSURED</b> First Student, Inc. 191 Rosa Parks Street, 8th Floor Cincinnati OH 45202 USA	<b>INSURER(S) AFFORDING COVERAGE</b>		<b>NAIC #</b>
	<b>INSURER A:</b> Old Republic Insurance Company		24147
	<b>INSURER B:</b> AIU Insurance Company		19399
	<b>INSURER C:</b> National Union Fire Ins Co of Pittsburgh		19445
	<b>INSURER D:</b>		
	<b>INSURER E:</b>		

**COVERAGES**      **CERTIFICATE NUMBER:** 570104744429      **REVISION NUMBER:**

THIS IS TO CERTIFY THAT THE POLICIES OF INSURANCE LISTED BELOW HAVE BEEN ISSUED TO THE INSURED NAMED ABOVE FOR THE POLICY PERIOD INDICATED. NOTWITHSTANDING ANY REQUIREMENT, TERM OR CONDITION OF ANY CONTRACT OR OTHER DOCUMENT WITH RESPECT TO WHICH THIS CERTIFICATE MAY BE ISSUED OR MAY PERTAIN, THE INSURANCE AFFORDED BY THE POLICIES DESCRIBED HEREIN IS SUBJECT TO ALL THE TERMS, EXCLUSIONS AND CONDITIONS OF SUCH POLICIES. LIMITS SHOWN MAY HAVE BEEN REDUCED BY PAID CLAIMS. **Limits shown are as requested**

INSR LTR	TYPE OF INSURANCE	ADDITIONAL INSURED	SUBROGATION	POLICY NUMBER	POLICY EFF (MM/DD/YYYY)	POLICY EXP (MM/DD/YYYY)	LIMITS
A	<input checked="" type="checkbox"/> COMMERCIAL GENERAL LIABILITY <input type="checkbox"/> CLAIMS-MADE <input checked="" type="checkbox"/> OCCUR  GEN'L AGGREGATE LIMIT APPLIES PER: <input type="checkbox"/> POLICY <input checked="" type="checkbox"/> PROJECT <input checked="" type="checkbox"/> LOC OTHER:			MWZY31683724 SIR applies per policy terms & conditions	04/01/2024	04/01/2025	EACH OCCURRENCE \$2,000,000 DAMAGE TO RENTED PREMISES (Ea occurrence) \$2,000,000 MED EXP (Any one person) PERSONAL & ADV INJURY \$2,000,000 GENERAL AGGREGATE \$2,000,000 PRODUCTS - COMP/OP AGG \$2,000,000
A	<input checked="" type="checkbox"/> AUTOMOBILE LIABILITY  <input checked="" type="checkbox"/> ANY AUTO <input type="checkbox"/> OWNED AUTOS ONLY <input type="checkbox"/> SCHEDULED AUTOS <input type="checkbox"/> HIRED AUTOS ONLY <input type="checkbox"/> NON-OWNED AUTOS ONLY			MWTB-316836-24 AOS	04/01/2024	04/01/2025	COMBINED SINGLE LIMIT (Ea accident) \$2,000,000 BODILY INJURY (Per person) BODILY INJURY (Per accident) PROPERTY DAMAGE (Per accident)
	<input type="checkbox"/> UMBRELLA LIAB <input type="checkbox"/> OCCUR <input type="checkbox"/> EXCESS LIAB <input type="checkbox"/> CLAIMS-MADE <input type="checkbox"/> DED <input type="checkbox"/> RETENTION						EACH OCCURRENCE AGGREGATE
B	<b>WORKERS COMPENSATION AND EMPLOYERS' LIABILITY</b> ANY PROPRIETOR / PARTNER / EXECUTIVE OFFICER/MEMBER EXCLUDED? (Mandatory in NH) If yes, describe under DESCRIPTION OF OPERATIONS below		Y/N <input checked="" type="checkbox"/> N    N/A	WC020396032 AOS WC020396033 CA	04/01/2024	04/01/2025	<input checked="" type="checkbox"/> PER STATUTE <input type="checkbox"/> OTHER E.L. EACH ACCIDENT \$2,000,000 E.L. DISEASE-EA EMPLOYEE \$2,000,000 E.L. DISEASE-POLICY LIMIT \$2,000,000
C	Excess Workers Compensation			XWC3332306 SIR applies per policy terms & conditions	04/01/2024	04/01/2025	EL Each Accident \$5,000,000 EL Disease - Policy \$5,000,000 EL Disease - Ea Emp \$5,000,000

DESCRIPTION OF OPERATIONS / LOCATIONS / VEHICLES (ACORD 101, Additional Remarks Schedule, may be attached if more space is required)  
RE: Proposal to provide student transportation services. Lincolnwood School District 74, its boards, officers, employees, students and agents thereof are included as Additional Insured in accordance with the policy provisions of the General Liability and Automobile Liability policies. Umbrella follows form coverage. A waiver of Subrogation is granted in favor of Certificate Holder in accordance with the policy provisions of the General Liability policy. First Student, Inc. provides self-administered Auto-Medical Payments coverage.

### CERTIFICATE HOLDER

### CANCELLATION

Lincolnwood School District #74 6950 N. East Prairie Road Lincolnwood IL 60712 USA	SHOULD ANY OF THE ABOVE DESCRIBED POLICIES BE CANCELLED BEFORE THE EXPIRATION DATE THEREOF, NOTICE WILL BE DELIVERED IN ACCORDANCE WITH THE POLICY PROVISIONS.  AUTHORIZED REPRESENTATIVE   91
---	---

Holder Identifier :

Certificate No : 570104744429

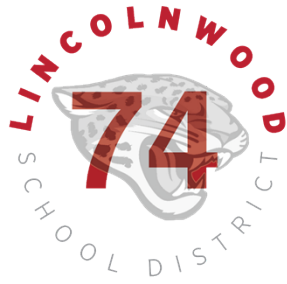

## Executive Summary Finance Committee Meeting

---

DATE: April 18, 2024

TOPIC: LBSA Waiver Request- FY25 Facilities Rental Fees

PREPARED BY: Courtney Whited

### **Recommended for:**

- Action
- Discussion
- Information

### **Purpose/Background:**

Lincolnwood Baseball and Softball Association (LBSA) has used SD74 facilities and fields for practices and games for several years. LBSA is a Category II organization according to the Facility Rental Policy updated in September 2019. The resulting fees would create an extreme hardship on LBSA. The organization's waiver request is attached.

### **Fiscal Impact:**

Category II fees for the gyms and outdoor fields would not be collected during FY25

### **Recommendation:**

The Finance Committee concurs with the Administration's recommendation to the Board of Education to waive facility rental fees during fiscal year 2024-25 for Lincolnwood Baseball and Softball Association.



PO BOX 46443  
Chicago, IL 60646

**www.lwbba.org**

**LBA Board Members**

**John Dreuth**  
*President*

**Rick Hoffman**  
*Vice President*

**Mike Bartholomew**  
*Vice President*

**David Spitz**  
*Co-Secretary*

**Carrie Spitz**  
*Co-Secretary*

**Donna Dreuth**  
*Treasurer*

**Jeron Dorsey**  
*Village Liaison*

**Ben Friedman**  
*Director*

**Joe Osborne**  
*Director*

**Peter Kougias**  
*Director*

**Adam Kolovic**  
*Director*

**Susan Kougias**  
*Director*

**Eileen Canney Linnehan**  
*Director*

**Kira Hoffman**  
*Director*

**Alex Stojanoff**  
*Director*

**Chris Hutchison**  
*Director*

**Rich Barnes**  
*Director*

**Jay Greenberger**  
*Director*

**Matt Ceisel**  
*Director*

April 1, 2024

**Lincolnwood School District 74 Board of Education:**

Lincolnwood Baseball and Softball Association (LBSA) has used SD74 facilities and fields for many years. LBSA requests that all rental fees continue to be waived in the use of the SD74 facilities and fields.

Sincerely,

A handwritten signature in cursive script that reads "John Dreuth".

John Dreuth  
President, LBSA

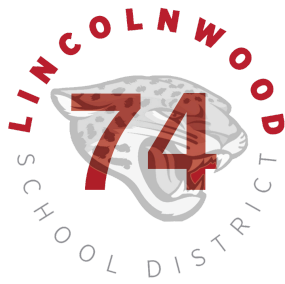

## Executive Summary Finance Committee Meeting

DATE: April 18th, 2024

TOPIC: Infinite Connections Inc. Agreement Renewal

PREPARED BY: Jordan Stephen

### **Recommended for:**

- Action
- Discussion
- Information

### **Purpose/Background:**

Infinite Connections, Inc. has provided Lincolnwood District #74 E-Rate consultation services since 2014. The District has worked with Jane Kratochvil for many years on both E-Rate and ECF Funding. This is the ten extension to the original Agreement and will be in effect from February 1, 2024 through January 31, 2025.

District Legal Counsel has reviewed this Extension to the Consulting Services Agreement and found it acceptable. Counsel noted that this Agreement only extends the terms by an additional year, and does not modify the original terms of the Agreement.

### **Fiscal Impact:**

\$4,600 - Lincolnwood School District 74 paid Infinite Connections, Inc. \$4,400 in for the same services during the 2023-2024 School year.

### **Recommendation:**

The Finance Committee concurs to recommend to the Board of Education to approve the Infinite Connections, Inc. Agreement for Consulting Services in the amount of \$4,600 from February 1, 2023 to January 31, 2024.

## **TENTH EXTENSION TO CONSULTING SERVICES AGREEMENT**

This Tenth Extension (“Extension”) is effective as of February 1, 2024, by and between **Infinite Connections, Inc.** (hereinafter “**Consultant**” or “**ICI**”) and **Lincolnwood School District #74** (hereinafter “**Client**”) and has been entered into as of the later of the dates appearing after the signatures of the parties or their duly authorized representatives, which are set forth below.

### **RECITALS**

A. The Consultant and Client entered into that certain Consulting Agreement dated February 6, 2014 in which Consultant agreed to render certain services for a term commencing February 6, 2014 and ending on January 31, 2015 which was further amended on June 14, 2014, extended on February 1, 2015; and further amended and extended on February 1, 2016, February 1, 2017 and February 1, 2018 (the original agreement, and its subsequent amendments and extensions and collectively referred to as the “**Agreement**”);

B. The parties hereto desire to extend the Agreement as set forth herein.

### **AGREEMENT**

**NOW, THEREFORE**, in consideration of the mutual covenants and conditions contained herein, the parties hereto agree as follows:

1. **Term:** The parties agree to extend the term of the Agreement commencing from February 1, 2024, through January 31, 2025 (“Extension Period”).
2. **Scope of Services:** During the Extension Period, Consultant shall provide the Services and Deliverables as described in Attachment A to the Agreement to support E-rate Funding Years 16, 17, 18, 19, 20, 21, 22, 23, 24, 25, 26 & 27.
  - a. The parties agree to delete Section A, Section 1.1 of the “Agreement in its entirety and replace it with the following”.

“E-Rate Forms Processing and Submission. Assess and work with Client to complete all forms and processes related to all Category One and Category Two applications of the Federal Communications Commission E-Rate filing with the Schools and Libraries Division (“SLD”) for filing years 2013-2014 (YR16), 2014-2015 (YR17), 2015-2016 (YR18), 2016-2017 (YR19) and 2017-2018 (YR20), 2018-2019 (YR21), 2019-2020 (YR22), 2020-2021 (YR23), 2021-2022 (YR24), 2022-2023 (YR25), 2023-2024 (YR26), 2024-2025 (YR27)

3. **Compensation:** “Invoicing and Compensation” of the **Agreement**, is amended as follows.
  - a. The parties agree to delete Section A titled “Invoicing and Compensation” in Attachment A in its entirety and replace with the following:

Consultant will invoice Client quarterly. Payment is due within thirty (30) days of Client's receipt of each invoice and after Client approves of the same. Based on the terms set forth in this Agreement, Consultant's fees for Services as defined herein shall not exceed a fixed amount of \$4,600.00 for the duration of the term for E-Rate Consulting and Administrative Support. All payments under this contract will be in compliance with the Local Government Prompt Payment Act (50 ILCS 505/1 et seq.).

If any of Client's Obligations, as defined herein are not performed or prove to be incorrect as described in this Agreement, it may cause changes to the fees and expenses, Deliverables, level of effort required, or otherwise impact Consultant's performance of the Services described in this Agreement. Any such changes to the fees and expenses, Deliverables, level of effort required, or Consultant's performance shall be communicated to Client prior to any such changes taking effect.

4. **Letter of Agency**: The Letter of Agency attached hereto to as Attachment B-2 is incorporated into this Extension by this reference.
5. **Original Agreement**: Except as specifically provided in this Extension, all terms and conditions of the Agreement shall remain in full force and effect.

IN WITNESS WHEREOF, the parties hereto have caused this Extension to be executed by their duly authorized representatives as of the date first above written.

**Infinite Connections, Inc.**

By: \_\_\_\_\_  
Jane Kratochvil, President

Date: \_\_\_\_\_

**Board of Education, Lincolnwood District #74**

By: \_\_\_\_\_

Name: \_\_\_\_\_

Title: \_\_\_\_\_

Date: \_\_\_\_\_

## ATTACHMENT B-2 – LETTER OF AGENCY

### FUNDING YEARS (2013, 2014, 2015, 2016, 2017, 2018, 2019, 2021, 2022, 2023, 2024, 2025 & 2026)

I, on behalf of the **Lincolnwood School District 74** (“CLIENT”), hereby authorize Infinite Connections, Inc. (“ICI”) to assist the CLIENT in its E-rate application process on behalf of the CLIENT. I also hereby authorize Infinite Connections, Inc. to respond on CLIENT’S behalf to requests by the Federal Communication Commission (“Commission” or “FCC”), School and Libraries Division of the Universal Service Administrative Company (“SLD/USAC”), Program Integrity Assurance Reviews (“PIA”) or any other person or entity acting on their behalf, relating to any and all E-rate related matters. I authorize ICI to prepare all required FCC forms for services as requested by CLIENT. The relevant time period for this letter of agency is February 1, 2024, through January 31, 2025.

By signing this Letter of Agency, I make the following certifications to ICI on behalf of the CLIENT:

- (a) I certify that Client has provided schools operated by CLIENT are eligible for support because they are schools under the statutory definition of elementary and secondary schools found in the **No Child Left Behind Act of 2001, 20 U.S.C. §§ 7801 (18) and (38)**, that do not operate as for-profit businesses and do not have endowments exceeding \$50 million.
- (b) I certify that CLIENT has secured access, separately or through this program, to all of the resources, including computers, training, software, internal connections, maintenance, and electrical capacity, necessary to use the services purchased effectively. I certify and recognize that some of the aforementioned resources are not eligible for support. I certify that CLIENT has secured access to all of the resources to pay the discounted charges for eligible services from funds to which access has been secured in the current funding year. I certify that the CLIENT will pay the non-discount portion of the cost of the goods and services to the Service Provider(s).
- (c) I certify that CLIENT has posted FCC Form 470 and that any related RFP was made available for at least 28 days before considering all bids received and selecting a service provider. I certify that all bids submitted were carefully considered by CLIENT and the most cost effective service offering was selected by CLIENT, with price being the primary factor considered, and is the most cost-effective means of meeting CLIENT's educational needs and technology goals.
- (d) If CLIENT has determined that CLIENT has selected an eligible commercially available business-class Internet access service, then I certify CLIENT is exempt from the requirement to post an FCC Form 470.
- (e) If CLIENT has determined CLIENT will use an eligible preferred master contract, then I certify that the services ordered by CLIENT were exempt from the requirement to post an FCC Form 470.
- (f) I certify that the services CLIENT purchases at discounts provided by 47 U.S.C. § 254 will be used primarily for educational purposes, see 47 C.F.R. § 54.500, and will not be sold, resold, or transferred in consideration for money or any other thing of value, except as permitted by the Commission's rules at 47 C.F.R. § 54.513. Additionally, I certify that the CLIENT has not received anything of value or a promise of anything of value, other than services and equipment sought by means of this form, from the service provider, or any representative or agent thereof or any consultant in connection with this request for services.
- (g) I certify that CLIENT has complied with all program rules, including recordkeeping requirements, and I acknowledge that CLIENT's failure to do so may result in denial of discount funding and/or

cancellation of funding commitments. There are signed contracts or other legally binding agreements covering all of the services listed on any FCC Form 471 except for those services provided under non-contracted tariffed or month-to-month arrangements. I certify that CLIENT has acknowledged that failure to comply with program rules could result in civil or criminal prosecution by the appropriate law enforcement authorities.

- (h) I acknowledge, and CLIENT is aware, that the discount level used for shared services is conditional, for future years, upon ensuring that the most disadvantaged schools and libraries that are treated as sharing in the service, received an appropriate share of benefits from those services.
- (i) I certify that CLIENT will retain required documents for a period of at least ten (10) years (or whatever retention period is required by the rules in effect at the time of this certification), after the last day of service delivered. I certify that CLIENT will retain all documents necessary to demonstrate compliance with the statute and Commission rules regarding the application for, receipt of, and delivery of services receiving schools and libraries discounts, and that if audited, CLIENT will make such records available to the Administrator. I acknowledge that CLIENT may be audited pursuant to participation in the Schools and Libraries programs.
- (j) I certify that I am authorized to order telecommunications and other supported services for CLIENT. I certify that I am authorized to submit requests, and sign this Letter of Agency on behalf of the CLIENT, that I have examined this Letter of Agency, that all of the information on this Letter of Agency and which I will provide pursuant to this Letter of Agency is true and correct to the best of my knowledge, that the CLIENT that is receiving discounts pursuant to CLIENT's applications have complied with the terms, conditions and purposes of the program, that no kickbacks were paid or will be paid to anyone and that false statements on any forms or through this Letter of Agency can be punished by fine or forfeiture under the Communications Act, 47 U.S.C. § 502, 503(b), or fine or imprisonment under Title 18 of the United States Code, 18 U.S.C. § 1001 and civil violations of the False Claims Act.
- (k) I certify that CLIENT has reviewed and complied with all applicable FCC, state and local procurement/competitive bidding requirements and that CLIENT has complied with them
- (l) I acknowledge on behalf of CLIENT that FCC rules provide that persons who have been convicted of criminal violations or held civilly liable for certain acts arising from their participation in the schools and libraries support mechanism are subject to suspension and debarment from the program. I certify CLIENT will institute reasonable measures to be informed, and will notify USAC should CLIENT be informed or become aware that CLIENT, or any person associated in any way with CLIENT, is convicted of a criminal violation or held civilly liable for acts arising from their participation in the school and libraries support mechanism.
- (m) I certify that if any Funding Requests are for discounts for products or services that contain both eligible and ineligible components for CLIENT, that I and/or CLIENT will allocate the eligible and ineligible components as required by the Commission's rules at 47 C.F.R. § 54.504.
- (n) I certify that CLIENT acknowledges that the non-discount portion of the costs for eligible services will not be paid by the service provider. The pre-discount costs of eligible services provided by CLIENT are and will be net of any rebates or discounts offered by the service provider. I and CLIENT acknowledge that, for the purpose of this rule, the provision, by the provider of a

supported service, of free services or products unrelated to the supported service or product constitutes a rebate of some or all of the cost of the supported services.

- (o) I certify that I will cooperate with ICI, on behalf of CLIENT, in responding to any inquiry from the SLD/USAC about this certification or any other representation made in this Letter of Agency
- (p) I certify that I am authorized to sign this Letter of Agency on behalf of CLIENT and, to the best of my knowledge, information, and belief, all information provided to ICI for E-rate submission is true and correct.

ON BEHALF OF LINCOLNWOOD SCHOOL DISTRICT #74	
<i>Signature:</i>	<i>Date:</i>
Name/Title:	

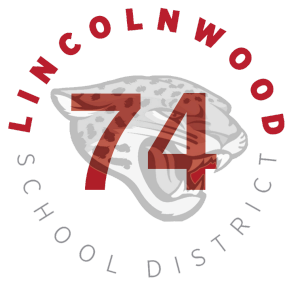

## Executive Summary Finance Committee Meeting

---

DATE: April 18th, 2024

TOPIC: Kings III Emergency Elevator Phone

PREPARED BY: Jordan Stephen

### **Recommended for:**

- Action
- Discussion
- Information

### **Purpose/Background:**

Over the past few years, the Technology Department has assessed all District telecommunication services, and made decisions to help reduce overall operating costs and maintain fiscal responsibility. One of the last significant transitions involved replacing our AT&T infrastructure with IP Flex technology, providing the district with the same volume of inbound and outbound calls at a fraction of the price.

During this transition, we identified two lines related to our elevator service, which necessitated a different approach. Once known as a POTS line, these phone lines are extremely costly. Earlier this year, we encountered issues with one of the elevator circuits at Rutledge Hall, which stemmed from underground issues. We implemented a workaround by rerouting the phone number through the IP Flex circuit, which works, but is not a perfect solution.

At the request of the Finance Committee, the team continued to look for solutions and found Kings III, a company that specializes in elevator and emergency communications. With over 30 years of service, this vendor will provide the equipment and installation needed to convert our existing POTS lines into a cost effective cellular communications signal.

District Legal Counsel reviewed the contract and had requested that the vendor make some standard minor modifications to the contract. The vendor has agreed to these changes and provided a new contract. Counsel also indicated that since the vendor can program these devices to use multiple carriers, there is no need for a separate contract for cellular service contracts as this is all handled under the normal monthly fees.

### **Fiscal Impact:**

\$98.34 per month plus taxes. The District currently pays \$355.71 per month for a single POTS elevator line at Lincoln Hall. Initial savings would total around \$3200 per year.

**One Time Fees:**

Qty	Description	Price Per Unit	Total
2	Scheduled Phone Installation	\$184.00	<b>\$368.00</b>

**Monthly Costs:**

Qty	Description	Price Per Unit	Total
2	GSA Schedule Phone	\$24.17	\$48.34
2	GSA Open Market Item Service	\$15.00	\$30.00
2	UPGRADE To FirstNet Priority Network	\$10.00	\$20.00
			<b>\$98.34</b>

**Recommendation:**

The Finance Committee concurs with the Administration's recommendation to the Board of Education to approve this Agreement from Kings III for Cellular Elevator Phones in the amount of \$98.34 plus required taxes and fees, beginning June 1, 2024. (Estimated)

# CELLULAR EXPLAINED

## How Exactly Does Our Skyline Cellular Service Work?

Skyline completely eliminates dependency on POTS lines (Plain Old Telephone Service) by leveraging the mobile network.

For elevators, our solution uses a traditional ADA compliant handsfree phone in each elevator cab. The cellular transceiver is located outside of the concrete & steel-lined shaft.

Traditionally our Skyline cellular unit is placed in a telco room. When necessary, we will install elsewhere on site to achieve a better signal so long as there is a power outlet available.

Skyline utilizes existing wiring in the building (typically between the telecom room and/or machine room and then through the travel cable into the elevator cab) to connect the cellular transceiver to the elevator cab.

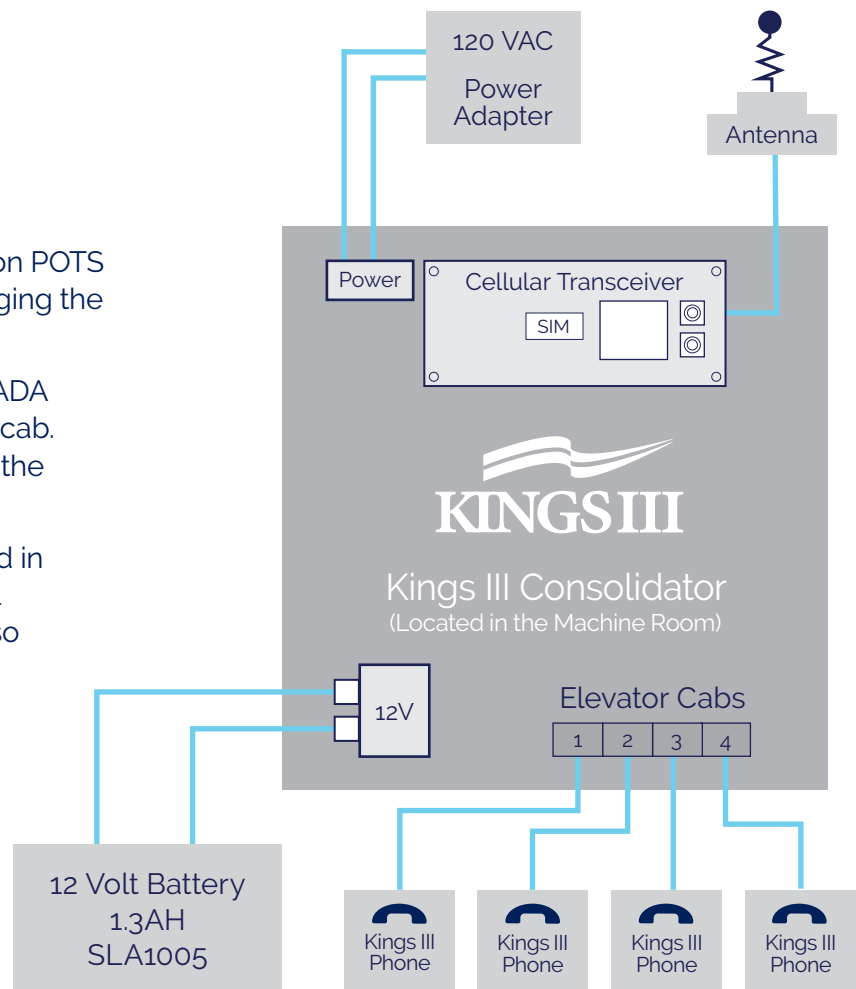

### IMPORTANT TO NOTE

While the signal enters the building in a "wireless" fashion, there is copper wiring required to connect the dial tone all the way to the elevator cab. This is probably the most common misconception we see.



Elevators | Parking | Pools | Stairwells | Areas of Refuge

800.393.5858 | <sup>102</sup>kingsiii.com

# FREQUENTLY ASKED QUESTIONS

**Q:** Will customers be responsible for providing the cellular connectivity?

**A:** No. Kings III provides cellular signals. We have agreements with multiple carriers — often at a lower cost than you would find if you were to buy the line yourself. This is a turnkey solution where we provide the hardware and access to the cellular signal, no need for the client to sign up with a wireless carrier for another monthly bill.

**Q:** Is wiring required?

**A:** Yes, while we typically think of cellular and wireless as interchangeable, that is not the case for emergency phones. While the signal enters the building in a “wireless” fashion, there is copper wiring required to connect the dial tone all the way to the elevator cab.

**Q:** What if there is no existing wiring from the machine room to the elevator?

**A:** If a short distance (roughly <75 feet), we can generally run that wiring for you. If a longer distance or there is some special circumstance, we will reach out to let you know you will need to hire a structured cabling contractor.

**Q:** Is the service reliable?

**A:** Because our business is focused on life safety, we recognize the importance of having a reliable signal. We test coverage before installation, and can also remotely locate the cellular transceiver away from the phone (if necessary) to achieve the best signal strength.

**Q:** How does the speed of transmission compare to traditional landlines?

**A:** Skyline uses 4G LTE data to deliver information to the EDC faster than previous analog technologies, allowing the call to be delivered sooner to the EDC Operator.



# VALUE COMPARISON

	 <b>KINGS III</b>	<b>LOCAL ELEVATOR COMPANIES</b>	<b>NATIONAL ELEVATOR COMPANIES</b>	<b>ELEVATOR COMMUNICATION TECHNOLOGY COMPANIES</b>	<b>LANDLINE REPLACEMENT COMPANIES</b>
<b>24/7 Live Authorized Personnel Emergency Reponse &amp; Dispatch</b>					
Real-Time Reporting of Entrapments per Customer Notification Plan**	✓	✗	✗	✗	✗
Operators More Highly Trained Than Generally Required of 911 Centers***	✓	✗	✗	✗	✗
Call Recording & Transcript Access	✓	✗	NOT TYPICAL	✗	✗
<b>Equipment &amp; Technology</b>					
Cellular Device Offering Built Specifically for Elevator Emergency Communications	✓	NOT TYPICAL	✓ *	✗	✗
Automatic Remote Testing for Communication Path Failure	✓	✗	✗	✗	NOT TYPICAL
Access to the FirstNet® Cellular Network****	✓	✗	✗	✗	✗
<b>Installation &amp; Service</b>					
Installed by Selling Vendor	✓	✓	✓	✗	✗
Who Recognizes & Submits a Support Ticket Upon Phone Line Failure (Cellular and Landline)?	<b>Kings III</b>	<b>Customer</b>	<b>Customer</b>	<b>N/A</b>	<b>N/A</b>
Lifetime Equipment Warranty & Ongoing Maintenance <b>Including Parts &amp; Labor</b>	✓	✗	✗	✗	✗
Code Compliance Expertise- Elevator Code (ASME), ADA, IBC	✓	NOT TYPICAL	✓ *	✗	✗

\*Asterisked services can typically be found among national elevator companies but are not guaranteed

\*\* Kings III works with customer to develop a customized call list used to ensure immediate help is dispatched as needed and appropriate building personnel are notified

\*\*\* Advanced Emergency Medical Dispatch (AEMD) Certified, Red Cross CPR Trained, & HIPAA Compliant

\*\*\*\* FirstNet is the reliable, highly secure, interoperable, and innovative public safety communications platform built with and for first responders, allowing access to a prioritized emergency network



# GSA Scheduled Emergency Phone Services Agreement

THIS AGREEMENT is entered into by and between **Kings III of America, LLC dba Kings III Emergency Communications**, 751 Canyon Drive, Suite 100, Coppell, TX 75019 (hereinafter "Kings III"), and Lincolnwood School District 74

## INSTALLATION/SERVICE LOCATIONS

## BILLING EMAIL \_\_\_\_\_

**Rutledge Hall School (1 Elevator)**  
6850 E. Prairie Rd.  
Lincolnwood, IL 60712

**Lincoln Hall School (1 Elevator)**  
6855 N. Crawford Ave  
Lincolnwood, IL 60712

## 1. SERVICES

- 1.1 Equipment: Kings III agrees to provide the equipment detailed in Section 3. below, as part of the monitoring, maintenance and dispatch services, collectively the Services. If no equipment is listed, none is provided by Kings III.
- 1.2 **Monthly Services:** Client agrees to pay Kings III for Services **Monthly** in advance.  
**Connection: USD \$368.00 Monthly: USD \$78.34 (Plus Applicable Tax)**  
(Based on normal installation) & due upon completion of installation.  
 **Automated Testing Service included** (See Section 11.4)  
E-mail: \_\_\_\_\_
- 1.3 Kings III GSA Product Table

## 2. TERMS OF THIS AGREEMENT

- 2.1 The primary term of this Agreement shall be for a period of One (1) Year from the date of the first billing ("Primary Term"). This Agreement shall automatically renew for a One (1) Year period at the end of such primary term ("Renewal Term") or any Renewal Term thereafter unless Client shall have written notice to Kings III Thirty (30) Days before the end of any Primary or Renewal Term.
- 2.2 Payments are to be payable **Monthly** in advance. Connection fees are due upon completion of installation.

## 3. EQUIPMENT TO BE INSTALLED

### 3.1

Quantity	Product Type	Connection Fee (per device)	Monthly Fee (per device)
2	GSA Schedule Phone	\$ 184.00 EA = 368.00	\$ 24.17 EA = 48.34
2	GSA Open Market Item	\$ -	\$ 15.00 EA = 30.00

## 4. EMERGENCY NOTIFICATION LIST



Listed below are persons designated by Client to be notified if Kings III receives a Monitored Call. We understand that Kings III will make every reasonable effort to notify one of these persons and will attempt notification in the order listed. **Client is responsible for advising Kings III of any changes desired by Client to contact names, telephone numbers, or list order. Client is also responsible for any fees, fines, damages, or charges arising from Kings III's dispatching any party on the Notification List in response to a Monitored Call.**

**Name** (Area Code) & Number **Email**

Call 1<sup>st</sup>: \_\_\_\_\_  
(Recommend Entering Elevator Company's Name & Phone Number)

Call 2<sup>nd</sup>: \_\_\_\_\_

Call 3<sup>rd</sup>: \_\_\_\_\_

Call 4<sup>th</sup>: Fire Rescue (Called 1st in event of emergency) (On file with Emergency Dispatch Center)

Onsite Installation Contact: \_\_\_\_\_

\*\*Automated Testing Service Email (See Section 11.4): \_\_\_\_\_

## 5. ADDITIONAL TERMS

- 5.1 All required wire runs, conduit runs and/or trenching will not be provided by Kings III unless otherwise noted herein.  
**Customer is purchasing off GSA Advantage Schedule #GS07F0420T**

## 6. CLIENT SELECTED SERVICES

- 6.1 Client desires and has contracted for only the equipment and services itemized on this Agreement. Additional services over and above that provided herein are neither expressed nor implied by Kings III.

## 7. WARRANTIES

7.1 There are no understandings, representations, or warranties of any kind - expressed, implied, statutory or otherwise, that are not expressly set forth herein.

## 8. COVERED SERVICE & CHARGES

8.1 Kings III agrees to maintain and repair its equipment while installed at Client's location during the term of this Agreement. There will be no charge to the Client for repairs required due to faulty Kings III equipment performed during business hours. Covered Service will not apply to: (a) batteries, (b) wiring not provided by Kings III; (c) service need caused by acts beyond the control of Kings III such as accidents, power surges, misuse, neglect, unauthorized change, or acts of God (including but not limited to lightning, fires, earthquakes, tornadoes, hurricanes, floods, etc.). Should repairs be necessitated that are not Covered Service, such work shall be billed to Client based upon Kings III's rates for parts and labor in effect at the time of the service.

## 9. INCREASES IN SERVICE CHARGES

9.1 INTENTIONALLY REMOVED BY KINGS III.

## 10. INCREASES IN TAXES OR OTHER FEES

10.1 REMOVED AT REQUEST OF CLIENT.  
10.2 REMOVED AT REQUEST OF CLIENT.

## 11. CLIENTS DUTIES AS TO USE OF SYSTEM

11.1 The Client shall be responsible for carefully and properly test activating the emergency telephone system(s), "The System(s)", on a monthly basis during the term of this Agreement. If any defect in the operation of The System develops, or in the event of a power failure, interruption of telephone service, or any other interruption at Client's premises, Client shall notify Kings III immediately.

11.2 Client shall notify Kings III of any remodeling or any other changes to the protected premises that may affect the operation of The System.

11.3 Client shall cooperate with Kings III in the installation, operation, and maintenance of The System and shall follow all instructions and procedures, which Kings III may prescribe for the operation and testing of The System.

11.4 Automated Testing Service is included but does not relieve Client of its duties under Section 11.1

## 12. AUTHORIZED PERSONNEL

12.1 Client is responsible for and agrees to furnish forthwith a list of the names and telephone numbers of all persons to be notified in the event of Kings III's receipt of a Monitored Call (See Section 17). Client is responsible for providing all changes, revisions, and modifications to the above list to Kings III in a timely manner.

## 13. BUSINESS HOURS

13.1 It is mutually agreed that the work of installation, repair, and any other required service shall be performed during normal business hours (8:00am – 5:00pm local time). Kings III assumes no responsibility for limited disruption of Client's premises for service required during normal business hours. Kings III shall make needed repairs to its equipment within a reasonable amount of time after Kings III receives notice that the repairs are necessary. If Client requests night or weekend service, such work shall be billed to client at Kings III's then prevailing overtime rate.

## 14. NO LIENS OR ENCUMBRANCES

14.1 Client agrees that it will not place any liens or encumbrances upon any of the equipment covered by this Agreement nor will it knowingly permit or cause such liens or encumbrances to be placed thereon by other persons; and in the event that any such liens or encumbrances are actually placed or permitted to be placed on such equipment, then Client, at his own cost and expense, shall take all legal steps necessary to have such liens or encumbrances removed forthwith or in lieu thereof, client shall, at its own cost and expense, furnish whatever bond is necessary to obtain the release and complete discharge of such equipment from liens and encumbrances. Client will not change or remove any insignia or lettering placed thereon by or at the request of Kings III.

## 15. ASSIGNMENT BY CLIENT

15.1 **Client may terminate this Agreement due to client's sale of the asset or upon loss of the third-party management contract at any time during the Term upon thirty (30) days written notice to Contractor. Additionally, should Kings III fail to perform Services in a commercially reasonable and workmanlike manner, Client is to send written notice detailing any deficiencies and allow reasonable opportunity for Kings III to rectify the problems. If Kings III is unable to provide satisfactory resolution this agreement may be terminated by Client. Client's obligation is to pay for services through the date of termination and allow Kings III to retrieve Kings III owned equipment.**

## 16. ASSIGNEES AND/OR SUBCONTRACTORS

16.1 Kings III shall have the right to assign this Agreement in whole or part to any other person, firm, or corporation and shall have the further right to subcontract any monitoring, maintenance, or other services which it may perform. Client acknowledges that the Agreement shall inure to the benefit and are applicable to any assignees and/or subcontractors of

Kings III, and that they bind Client with respect to said assignees and/or subcontractors with the same force and effect as they bind Client to Kings III. Kings III will notify Client of assignment Thirty (30) Days prior to assignment.

## 17. CENTRAL STATION MONITORING SERVICE

17.1 Notification Responsibilities: Kings III's sole responsibility when receiving a call from a telephone connected to The System, a "Monitored Call", is to notify those individuals or organizations in the order listed and designated by Client in Section 4 of this Agreement unless local code requires prior notification of Emergency Services, i.e. police, fire rescue or EMS. In such cases, Kings III shall notify the appropriate Emergency Service prior to notifying those individuals or organizations listed and designated by Client on the Emergency Notification List.

**17.2 Telephone Transmission Facilities: Client acknowledges that Kings III utilizes telephone line transmission unless SkyLine equipment is supplied in the product description on the front of hereof. The signals from Client's system are transmitted over Client's regular telephone service to Kings III, and in the event Client's telephone service is out of order, placed on vacation, or otherwise interrupted, signals from Client's system will not be received by Kings III during any such interruption in telephone service and the interruption will not be known to Kings III. Client further acknowledges and agrees that signals which are transmitted via telephone company facilities are wholly beyond the control and jurisdiction of Kings III and are maintained and serviced by the applicable telephone company. Client agrees, unless SkyLine equipment is supplied under Section 3 Equipment, to furnish any necessary telephone service or telephone lines at Client's own expense. Any and all telephone company charges shall be billed to Client's telephone bill. Any increased telephone company charges shall be borne by Client. If SkyLine equipment is supplied, Kings III shall be responsible for telephone/cellular service and airtime/usage charges. Client further acknowledges that the activation of the emergency communication system may interrupt and disconnect any telephone call in progress.**

17.3 Condition beyond control of Kings III: Kings III will use its best efforts to carry out its duties hereunder promptly, but shall not be responsible for delays or failure to respond by means of busy telephone facilities, failure of telephone equipment, or failure of telephone lines due to weather or other conditions, or otherwise for any conditions beyond the control of Kings III.

17.4 False Alarms: In the event there are an excessive number of false calls through the carelessness of Client or Client's tenants or the malicious or accidental use of the monitoring system, or in the event Client shall in any manner misuse or abuse the monitoring system, it shall constitute a material breach of this Agreement on the part of the Client, and Kings III may, at its option, in addition to all other legal remedies, be excused from further performance upon the giving of five (5) days written notice to Client.

## 18. ADDITIONAL SERVICE

18.1 The Client agrees that unless authorized by Kings III, any alterations, removal, or tampering with the equipment, or the attaching of any device, contrivance, or apparatus to the equipment or any part thereof, shall operate to void any warranties provided herein. If any agency or bureau having jurisdiction, or Client by his/its own act shall require or make necessary any changes in the equipment originally installed, Client agrees, on demand, to pay for the reasonable cost of such charges.

## 19. DEFAULT/TERMINATION

19.1 In the event (i) Client fails to pay any amount due for the system, (ii) client fails to comply with any of the terms and conditions hereof, (iii) Client makes an assignment for the benefit of Creditors, (iv) an order for relief is entered against Client under any chapter of the National Bankruptcy Code, as amended, (v) a receiver or trustee is appointed for all or substantially all of the assets of Client, or (vi) there is a dissolution or termination of existence of Client, Kings III may pursue any one or more of the following remedies, which are cumulative and non-exclusive:

(a) Terminate all services subscribed for hereunder by giving (5) days written notice to Client, and recover all amounts due Kings III.

(b) Take possession of all Kings III owned Equipment wherever situated and for such purpose enter upon your property without liability for doing so.

(c) By notice to Client, declare immediately due and payable all moneys to be paid by Client during the Primary Term, or if the Primary Term has then expired, declare immediately due and payable all monies to be paid during any Renewal Term (as provided in Paragraph 2.1 hereof) then in effect, and Client shall thereupon be obligated to pay such moneys to Kings III immediately. Client shall in any event remain fully liable for reasonable damages as provided by law and for all costs and expenses incurred by Kings III on account of such default including all court costs and reasonable attorney's fees. The waiver by Kings III of any breach of any obligation of Client shall not be deemed a waiver of such obligation or any subsequent breach of the same or any obligation. Kings III shall not deem the subsequent acceptance of payment hereunder by Kings III a waiver of prior existing breach regardless of Kings III's knowledge of such prior existing breach at the time of acceptance of such payments.

## 20. DELAYS OR INTERRUPTIONS

20.1 Kings III assumes no liability for delay in the installation of the system or for the interruption of services due to strikes, riots, floods, storms, earthquakes, fire, power failures, insurrection, interruption or unavailability of telephone or cable service, act of God, or for any other cause beyond the control of Kings III, and will not be required to provide installation for or services to Client while interruption of services due to any cause may continue.

20.2 Kings III assumes no liability for delay of installation due to non-cooperation of the Client or his agents in providing access to that area of the premises where the equipment is to be located, or for the delays or interruptions of installation or service on any device or devices of the Client or others to which Kings III's equipment is attached.

## 21. TELEPHONE SERVICE

21.1 Client agrees to furnish any necessary telephone service or telephone lines at Client's own expense. Any and all telephone charges shall be billed to Client's telephone bill. If SkyLine equipment is installed under Section 3, Kings III shall be responsible for telephone/cellular service and airtime/usage charges as detailed in Section 17.2.

**22. ELECTRICAL CURRENT**

22.1 Client agrees to furnish any necessary electrical service and current through Client's meter and at Client's sole expense.

**23. TITLE CLAUSE**

23.1 Paragraph titles used in this Agreement are for reference only and are not to be construed as governing the construction of the specific provisions of this Agreement.

**24. PAYMENTS AND DELINQUENCIES**

24.1 Payment shall be due as indicated on the front hereof. Kings III reserves the right to charge either Late Fees or Interest on all amounts more than thirty (30) days past due at the maximum allowable rate under applicable law. All payments shall be due and payable at Kings III's corporate offices first written above. If the Services are disconnected because of Client's past due balance, and if Client desires to have The Services reactivated, Client agrees to pay in advance to Kings III a reconnect charge to be fixed by Kings III at a reasonable amount.

**25. ENTIRE AGREEMENT/MODIFICATION/WAIVER/MISCELLANEOUS/GOVERNING LAW**

25.1 This writing is intended by the parties as a final expression of their agreement and as a complete and exclusive statement of the terms thereof. This Agreement supersedes all prior representation, understandings, or agreements of the parties, written or oral, and shall constitute the sole terms and conditions of the providing of all services detailed in Sections 1 and 3. This Agreement can be modified only in writing, signed by the parties or their duly authorized agent. No waiver or a breach of any term of this Agreement shall be construed to be a waiver of any succeeding breach.

25.2 If the Primary Term or the last Renewal Term has expired, but the Services are still being performed by Kings III on behalf of Client, then all terms and conditions set forth in this Agreement will remain in full force and effect until the Services are terminated by either party upon not less than thirty (30) days written notice from one party to the other.

25.3 The laws of the state of Texas govern the validity, enforceability, and interpretation of this Agreement.

**26. SEVERABILITY**

26.1 The provisions of this Agreement are intended to be severable. If any provision of this Agreement shall be held invalid or unenforceable in whole or in part in any jurisdiction, such provision shall, as to such jurisdiction, be ineffective to the extent of such invalidity or unenforceability without in any manner affecting the validity or enforceability thereof in any other jurisdiction or the remaining provisions hereof in any jurisdiction.

**CLIENT FURTHER ACKNOWLEDGES THAT IT HAS READ AND UNDERSTANDS ALL OF THIS AGREEMENT INCLUDING THE TERMS AND CONDITIONS ON THIS PAGE AND THE PRECEDING PAGES OF THIS AGREEMENT AND ANY EXHIBITS, SCHEDULES OR ADENDA OR AMENDMENTS AND ACKNOWLEDGES RECEIPT OF A TRUE COPY OF THIS AGREEMENT.**

IN WITNESS WHEREOF, and intending to be bound hereby, the parties hereto have executed this Agreement this \_\_\_\_\_ day of \_\_\_\_\_.

**Client:**

**Kings III of America, LLC**

By: \_\_\_\_\_  
Name: \_\_\_\_\_  
Title: \_\_\_\_\_  
Date: \_\_\_\_\_

By: \_\_\_\_\_  
Name: \_\_\_\_\_  
Title: \_\_\_\_\_  
Date: \_\_\_\_\_

This Agreement shall not be binding upon Kings III unless approved in writing by an authorized Manager of Kings III. In the event of non-approval, the sole liability of Kings III shall be to refund to Client the amount that has been paid to Kings III by Client upon execution of this Agreement.



## Executive Summary Finance Committee Meeting

DATE: April 18th, 2024

TOPIC: E Rate Category II – SHI Wireless Access Points

PREPARED BY: Jordan Stephen

**Recommended for:**

- Action
- Discussion
- Information

**Purpose/Background:**

The Administration has determined to continue with the modernization of the wireless infrastructure within the district. Over the last number of years the District has used E-Rate funds to replace switches, firewalls, wireless access points and various network equipment. This year, because of the funds that are available to the District in Category 2, the focus will shift to the purchase of the licenses required to run all of our wireless access points across the district.

This request was put out to bid through the E-Rate program. A total of five vendors submitted proposals for this e-rate project. Of the vendors submitting proposals, SHI earned the highest score. The Administration has attached SHI’s Proposal, E-Rate Service Provider Evaluation Worksheet, and SHI’s contract.

The District Legal Counsel has reviewed the Contract and found it acceptable. While there are a few lines that refer to terms that the District has pushed back on at times, legal does not believe it is necessary to pursue them here as the terms and conditions have remained unchanged from past years. Since SHI is a hardware vendor, SOPPA does not apply to this, as these licenses are a general commercial product and not a school-focused product.

Vendor	License Total
Heart Communication	\$52,000.20
Heartland Business Systems	\$55,428.80
Questivity	\$49,191.78
Redeye Networks Communication	\$55,581.40
SHI	\$48,160.00

**Fiscal Impact:**

The total cost is \$48,160.00. The District should anticipate an E-Rate reimbursement of \$19,264.

**Recommendation:**

The Finance Committee concurs with the Administration's recommendation to the Board of Education to approve this agreement from SHI for Meraki Network Licensing in the amount of \$48,160.00 from September 21, 2024 through September 21, 2029.

LINCOLNWOOD SCHOOL DISTRICT 74 - E-RATE YR27  
E-Rate Service Provider Evaluation Worksheet

Procurement Description

Budget Year: **2024**

Scope of Services: **Hardware only purchase of Meraki WAP, Controllers, and Cisco switches, and other network equipment.**

Form 470 Number: **240007936**

Request for Proposal: **Minimum Hardware Requirements**

Factor	Description	Maximum Points
A. Cost	Price of E-rate eligible services	40
B. Complete	Completeness / Quality of Proposal	25
C. Prior Exp	Familiarity with School	15
D. TechNeeds	Solution Meets the Needs of the District	20
E.		
		100

Scoring of Factors

Worst	1	2	3	4	5	Best
Fails criterion						Exceeds criterion

Tallying Points for Each Factor

Score  
5

Calculating Overall Points  
Sum Points for Each Factor

Name	Factor A Cost	Factor B Complete	Factor C Prior Exp	Factor D TechNeeds	Factor E 0	Total Points
Heart	3.0 <b>24.0</b>	5.0 <b>25.0</b>	1.0 <b>3.0</b>	4.0 <b>16.0</b>	0.0 <b>0.0</b>	<b>68.0</b>
Heartland	2.0 <b>16.0</b>	5.0 <b>25.0</b>	4.0 <b>12.0</b>	4.0 <b>16.0</b>	0.0 <b>0.0</b>	<b>69.0</b>
Questivity	5.0 <b>40.0</b>	5.0 <b>25.0</b>	1.0 <b>3.0</b>	4.0 <b>16.0</b>	0.0 <b>0.0</b>	<b>84.0</b>
RedEye	1.0 <b>8.0</b>	5.0 <b>25.0</b>	1.0 <b>3.0</b>	4.0 <b>16.0</b>	0.0 <b>0.0</b>	<b>52.0</b>
SHI	4.5 <b>36.0</b>	5.0 <b>25.0</b>	5.0 <b>15.0</b>	4.0 <b>16.0</b>	0.0 <b>0.0</b>	<b>92.0</b>
	0.0 <b>0.0</b>	0.0 <b>0.0</b>	0.0 <b>0.0</b>	0.0 <b>0.0</b>	0.0 <b>0.0</b>	<b>0.0</b>
	0.0 <b>0.0</b>	0.0 <b>0.0</b>	0.0 <b>0.0</b>	0.0 <b>0.0</b>	0.0 <b>0.0</b>	<b>0.0</b>

George Hu  
Evaluated by (printed)

  
Evaluated by (Signature)

2/7/24  
Evaluation Date

**LINCOLNWOOD SCHOOL DISTRICT 74 - E-RATE YR27  
E-Rate Service Provider Evaluation Worksheet**

**Procurement Description**

Funding Year	2024
Scope of Services	Hardware only purchase of Meraki WAP, Controllers, and Cisco switches, and other network equipment.
Form 470 Number	240007936
Request for Proposal	Minimum Hardware Requirements

Factor	Description	Maximum Points
A. Cost	Price of E-rate eligible services	40
B. Complete	Completeness / Quality of Proposal	25
C. Prior Exp	Familiarity with School	15
D. TechNeeds	Solution Meets the Needs of the District	20
E.		
		<b>100</b>

**Scoring of Factors**

Worst	1	2	3	4	5	Best
Fails criterion						Exceeds criterion

**Tallying Points for Each Factor**  
Score  
5

**Calculating Overall Points**  
Sum Points for Each Factor

Name	Factor A Cost	Factor B Complete	Factor C Prior Exp	Factor D TechNeeds	Factor E 0	Total Points
Heart	3.0 <b>24.0</b>	4.0 <b>20.0</b>	1.0 <b>3.0</b>	4.0 <b>16.0</b>	0.0 <b>0.0</b>	<b>63.0</b>
Heartland	2.0 <b>16.0</b>	5.0 <b>25.0</b>	3.0 <b>9.0</b>	4.0 <b>16.0</b>	0.0 <b>0.0</b>	<b>66.0</b>
Questivity	5.0 <b>40.0</b>	5.0 <b>25.0</b>	3.0 <b>9.0</b>	4.0 <b>16.0</b>	0.0 <b>0.0</b>	<b>90.0</b>
RedEye	1.0 <b>8.0</b>	4.0 <b>20.0</b>	1.0 <b>3.0</b>	4.0 <b>16.0</b>	0.0 <b>0.0</b>	<b>47.0</b>
SHI	4.5 <b>36.0</b>	5.0 <b>25.0</b>	5.0 <b>15.0</b>	4.0 <b>16.0</b>	0.0 <b>0.0</b>	<b>92.0</b>
	0.0 <b>0.0</b>	0.0 <b>0.0</b>	0.0 <b>0.0</b>	0.0 <b>0.0</b>	0.0 <b>0.0</b>	<b>0.0</b>
	0.0 <b>0.0</b>	0.0 <b>0.0</b>	0.0 <b>0.0</b>	0.0 <b>0.0</b>	0.0 <b>0.0</b>	<b>0.0</b>

Jordan Stephen  
Evaluated by (printed)

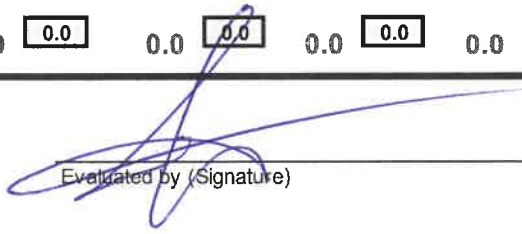
  
Evaluated by (Signature)

2/7/24  
Evaluation Date



**Exhibits –  
Contract Draft  
Pending Board Approval**



Pricing Proposal  
 Quotation #: 24571987  
 Created On: 3/4/2024  
 Valid Until: 7/1/2024

## IL-Village of Lincolnwood School District 74

## Inside Account Executive

### Jordan Stephen

6950 NE PRAIRIE RD  
 LINCOLNWOOD, IL 607122520  
 United States  
 Phone: 847-675-8234  
 Fax:  
 Email: jstephen@sd74.org

### Anthony Tammara

290 Davidson Ave  
 Somerset, NJ 08873  
 Phone: 732-667-2782  
 Fax: 732-564-8553  
 Email: anthony\_tammara@shi.com

All Prices are in US Dollar (USD)

Product	Qty	Your Price	Total
1 Meraki MR Enterprise License, 5YR Cisco Systems - Part#: LIC-ENT-5YR Contract Name: Open Market Contract #: Open Market <b>Note:</b> 100% E-Rate Eligible	140	\$344.00	\$48,160.00

Shipping	\$0.00
<b>Total</b>	<b>\$48,160.00</b>

### Additional Comments

SHI SPIN: #143012572  
 SHI-GS SPIN (For Texas customers ONLY): #143028315  
 For E-rate SPI orders, applicant shall be responsible for payment of any outstanding or ineligible costs if USAC rejects reimbursement claim in whole or in part.

Please note, if Emergency Connectivity Funds (ECF) will be used to pay for all or part of this quote, please let us know as we will need to ensure compliance with the funding program.

Hardware items on this quote may be updated to reflect changes due to industry wide constraints and fluctuations.

All orders for Cisco equipment and related software and services submitted, beginning on December 29, 2021, are non-cancelable and cannot be modified starting 45 days prior to the scheduled ship dates. Non-cancelable orders are not eligible for RMA for credit.

The following is related to the Cisco software items on this quote:

- Please see the following links to [Cisco's Security and Trust Center](#) , [Trust Portal](#) , [Online Privacy Statement](#) ,

as well as [Customer Master Data Protection Agreement](#) which all are incorporated by reference into the EULA

---

*The products offered under this proposal are Open Market and resold in accordance with the terms and conditions at [SHI Online Customer Resale Terms and Conditions](#).*

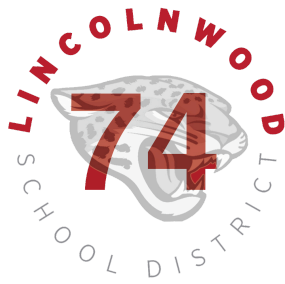

## Executive Summary Finance Committee Meeting

DATE: April 18th, 2024

TOPIC: E Rate Category I – AT&T High Speed Internet Access

PREPARED BY: Jordan Stephen

**Recommended for:**

- Action
- Discussion
- Information

**Purpose/Background:**

The District's current contract for 1000Mbps of Internet service with AT&T will expire in July 2024. The District, through the E-Rate program, requested proposals from vendors for Internet services providing various contract lengths and speeds. A total of three vendors submitted proposals and all were reviewed, discussed and rated. AT&T earned the highest score for the services that were requested. The Administration has attached the E-Rate service provider's evaluation worksheet as well as AT&T's Agreement.

By selecting a renewal with AT&T, this simplifies the extension process and keeps our current bandwidth at 1000 Mbps for the next two years. The new agreement with AT&T will also see a reduction in fees along with a 40% savings due to E-Rate.

District Legal Counsel has reviewed the contract and found it acceptable as they remain largely unchanged from the prior versions that were approved since 2022.

Vendor	Total
AT&T	\$999.60
Cytranet	\$1320.00
Astound	\$1515.00

**Fiscal Impact:**

\$999.60 per month. The District paid \$1,386.80 per month from July 2022 to July 2024 with AT&T.

**Recommendation:**

The Finance Committee concurs with the Administration's recommendation to the Board of Education to approve this Agreement from AT&T for Internet Services in the amount of \$999.60 per month from July 1, 2024 through June 30, 2026.

LINCOLNWOOD SCHOOL DISTRICT 74 - E-RATE YR27  
E-Rate Service Provider Evaluation Worksheet

Procurement Description

Budget Year: **2024**  
 Scope of Services: **1 Gbps Bandwidth/1 Gbps port, with potential upgrades to 2Gbps, 3 Gbps, up to 5 Gbps. Include any special construction one-time costs, as applicable. Price out a 24 and 36 month option for all bandwidth tiers. Leased lit fiber includes internet access.**  
 Form Number: **240003415**  
 Request for Proposal: **N/A**

Factor	Description	Maximum Points
A. Cost	Price of E-rate eligible services	30
B. Complete	Completeness / Quality of Proposal	25
C. Prior Exp	Familiarity with School	15
D. Service	Service Quality	20
E. TechExp	Solution Meets the Needs of the District	10
		100

Scoring of Factors

Worst	1	2	3	4	5	Best
Fails criterion						Exceeds criterion

Tallying Points for Each Factor  
Score  
5  
Calculating Overall Points  
Sum Points for Each Factor

Name	Factor A Cost	Factor B Complete	Factor C Prior Exp	Factor D Service	Factor E TechExp	Total Points
Astound	3.0 <b>18.0</b>	4.0 <b>20.0</b>	1.0 <b>3.0</b>	3.0 <b>12.0</b>	3.0 <b>6.0</b>	<b>59.0</b>
AT&T	5.0 <b>30.0</b>	5.0 <b>25.0</b>	5.0 <b>15.0</b>	5.0 <b>20.0</b>	5.0 <b>10.0</b>	<b>100.0</b>
Cytranet	1.0 <b>6.0</b>	4.0 <b>20.0</b>	1.0 <b>3.0</b>	3.0 <b>12.0</b>	3.0 <b>6.0</b>	<b>47.0</b>
	0.0 <b>0.0</b>	0.0 <b>0.0</b>	0.0 <b>0.0</b>	0.0 <b>0.0</b>	0.0 <b>0.0</b>	<b>0.0</b>
	0.0 <b>0.0</b>	0.0 <b>0.0</b>	0.0 <b>0.0</b>	0.0 <b>0.0</b>	0.0 <b>0.0</b>	<b>0.0</b>
	0.0 <b>0.0</b>	0.0 <b>0.0</b>	0.0 <b>0.0</b>	0.0 <b>0.0</b>	0.0 <b>0.0</b>	<b>0.0</b>
	0.0 <b>0.0</b>	0.0 <b>0.0</b>	0.0 <b>0.0</b>	0.0 <b>0.0</b>	0.0 <b>0.0</b>	<b>0.0</b>

George Hu  
Evaluated by (printed)

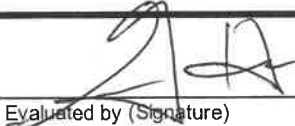
  
Evaluated by (Signature)

2/7/24  
Evaluation Date

**LINCOLNWOOD SCHOOL DISTRICT 74 - E-RATE YR27  
E-Rate Service Provider Evaluation Worksheet**

**Procurement Description**

Pending Year: **2024**

Scope of Services: **1 Gbps Bandwidth/1 Gbps port, with potential upgrades to 2Gbps, 3 Gbps, up to 5 Gbps. Include any special construction one-time costs, as applicable. Price out a 24 and 36 month option for all bandwidth tiers. Leased lit fiber includes internet access.**

Form 470 Number: **240003415**

Request for Proposal: **N/A**

Factor	Description	Maximum Points
A. Cost	Price of E-rate eligible services	30
B. Complete	Completeness / Quality of Proposal	25
C. Prior Exp	Familiarity with School	15
D. Service	Service Quality	20
E. TechExp	Solution Meets the Needs of the District	10
		<b>100</b>

**Scoring of Factors**

Worst	1	2	3	4	5	Best
Fails criterion						Exceeds criterion

**Tallying Points for Each Factor**  
Score  
5  
**Calculating Overall Points**  
Sum Points for Each Factor

Name	Factor A: Cost	Factor B: Complete	Factor C: Prior Exp	Factor D: Service	Factor E: TechExp	Total Points
Astound	4.0 <b>24.0</b>	4.0 <b>20.0</b>	2.0 <b>6.0</b>	4.0 <b>16.0</b>	3.0 <b>6.0</b>	<b>72.0</b>
AT&T	5.0 <b>30.0</b>	5.0 <b>25.0</b>	5.0 <b>15.0</b>	5.0 <b>20.0</b>	5.0 <b>10.0</b>	<b>100.0</b>
Cytranet	1.0 <b>6.0</b>	4.0 <b>20.0</b>	2.0 <b>6.0</b>	4.0 <b>16.0</b>	3.0 <b>6.0</b>	<b>54.0</b>
	0.0 <b>0.0</b>	0.0 <b>0.0</b>	0.0 <b>0.0</b>	0.0 <b>0.0</b>	0.0 <b>0.0</b>	<b>0.0</b>
	0.0 <b>0.0</b>	0.0 <b>0.0</b>	0.0 <b>0.0</b>	0.0 <b>0.0</b>	0.0 <b>0.0</b>	<b>0.0</b>
	0.0 <b>0.0</b>	0.0 <b>0.0</b>	0.0 <b>0.0</b>	0.0 <b>0.0</b>	0.0 <b>0.0</b>	<b>0.0</b>
	0.0 <b>0.0</b>	0.0 <b>0.0</b>	0.0 <b>0.0</b>	0.0 <b>0.0</b>	0.0 <b>0.0</b>	<b>0.0</b>

Jordan Stephen  
Evaluated by (printed)

  
Evaluated by (Signature)

2/7/24  
Evaluation Date



**AT&T DEDICATED INTERNET  
PRICING SCHEDULE**

<b>Customer</b>	<b>AT&amp;T</b>
LINCOLNWOOD SCHOOLS Street Address: 6950 N EAST PRAIRIE RD City: LINCOLNWOOD State/Province: IL Zip Code: 607122520 Country: United States	AT&T Corp.
<b>Customer Contact (for Notices)</b>	<b>AT&amp;T Contact (for Notices)</b>
Name: JORDAN STEPHEN Title: DIRECTOR OF TECHNOLOGY Street Address: 6950 N EAST PRAIRIE RD City: LINCOLNWOOD State/Province: IL Zip Code: 60712 Country: United States Telephone: 8476758234 Email: jstephen@sd74.org	Name: DANA SULPRIZIO Street Address: 1876 DATA DR City: HOOVER State/Province: AL Zip Code: 35244 Country: United States Telephone: 2055174474 Email: ds9454@att.com Sales/Branch Manager: GEM SURGE SCVP Name: GEM SURGE Sales Strata: Retail Sales Region: USA <b>With a copy (for Notices) to:</b> AT&T Corp. One AT&T Way Bedminster, NJ 07921-0752 ATTN: Master Agreement Support Team Email: <a href="mailto:mast@att.com">mast@att.com</a>
<b>AT&amp;T Solution Provider or Representative Information (if applicable)</b> <input type="checkbox"/>	
Name: Company Name: Agent Street Address: City: State: Zip Code: Country: Telephone: Fax: Email: Agent Code:	

This Pricing Schedule is part of the Agreement between AT&T and Customer referenced above and shall become effective when signed by authorized representatives of both parties ("Effective Date").

<b>Customer</b> (by its authorized representative)	<b>AT&amp;T</b> (by its authorized representative)
By:	By:
Name:	Name:
Title:	Title:
Date:	Date:

**AT&T and Customer Confidential Information**

**AT&T DEDICATED INTERNET  
PRICING SCHEDULE**

This Pricing Schedule shall replace and supersede in its/their entirety the following AT&T Dedicated Internet ("ADI"), Service Order Attachment(s) and/or Pricing Schedule(s) between AT&T and Customer:

MIS14368307	
-------------	--

**1. SERVICES**

Service	Service Publication Location
AT&T Dedicated Internet (ADI)	<a href="http://serviceguidenew.att.com/sg_flashPlayerPage/MIS">http://serviceguidenew.att.com/sg_flashPlayerPage/MIS</a>
AT&T Bandwidth Services	<a href="http://serviceguidenew.att.com/sg_flashPlayerPage/BWS">http://serviceguidenew.att.com/sg_flashPlayerPage/BWS</a>

**2. PRICING SCHEDULE TERM AND EFFECTIVE DATES**

<b>Pricing Schedule Term*</b>	<b>24 months</b>
<b>Pricing Schedule Term Start Date</b>	Effective Date of this Pricing Schedule
<b>Effective Date of Rates and Discounts</b>	Effective Date of this Pricing Schedule
<b>Pricing Schedule Term Extension Option</b>	Customer may extend the Pricing Schedule Term for one, two or three 12 month periods (each, an "Extension Period") upon written notice to AT&T at least forty-five (45) days prior to the expiration of the original Pricing Schedule Term (or of the first Extension Period, or of the second Extension Period if applicable). In such a case, the Minimum Payment Period for each Service Component shall expire at the later of the end of the applicable Extension Period or the expiration of its original Minimum Payment Period.

\*Price Stabilization does not apply to Services or Service Components that have been designated as grandfathered in the applicable Service Publication as of the Pricing Schedule Effective Date (Previously Grandfathered Service/Service Components). AT&T may change prices, discounts, terms or conditions for Previously Grandfathered Service/Service Components on 30 days' prior notice to Customer.

**3. MINIMUM PAYMENT PERIOD**

Service Components	Percent of Monthly Service Fees Due Upon Termination Prior to Completion of Minimum Payment Period	Minimum Payment Period per Service Component*
All Service Components	50%	Longer of 12 months or until the end of the Pricing Schedule Term

\*The Minimum Payment Period does not apply to Previously Grandfathered Service/Service Components.

**4. RATES (US Mainland, and HI only)****Section I: AT&T Dedicated Internet  
Access Bandwidth -****Table 1: DNS Services**

Option	Monthly Service Fee
Additional Primary DNS (available in increments of up to 15 zones with a maximum of 150 Kilobytes of zone file data)	\$100 per DNS increment
Additional Secondary DNS (available in increments of up to 15 zones with a maximum of 150 Kilobytes of zone file data)	\$100 per DNS increment

**AT&T and Customer Confidential Information**

Page 2 of 14

ASAP!

121

**AT&T DEDICATED INTERNET  
 PRICING SCHEDULE**

**Table 2: ADI Tele – Installation**

Discount: 100.00%

ADI Speed	Undiscounted ADI	Undiscounted ADI w/ Managed Router
56 Kbps	\$1,000	\$1,000
128 Kbps - 1.5 Mbps	\$1,000	\$1,000
NxT-1	\$2,500	\$2,500
Tiered/Full T-3	\$5,000	N/A
Tiered OC-3, OC-12, OC-48	\$10,000	N/A
Ethernet	\$1,500 <sup>#</sup>	\$1,500 <sup>**</sup>
10 Gig Ethernet* and up	\$1,500 <sup>#</sup>	\$1,500

\* Service not available with MPLS PNT.

\*\*Pricing available for ADI speeds of 100 Mbps and below and with electrical interfaces only.

<sup>#</sup> Pricing also applies to Service locations in Alaska.

**Table 3: On-Site Installation**

Discount: 100.00%

ADI Speed	Undiscounted ADI w/ Managed Router Only
56 Kbps	\$999
128 Kbps - 1.5 Mbps	\$999
NxT-1	\$999
Tiered/Full T-3	\$1,000
Tiered OC-3, OC-12, OC-48	\$10,000
Ethernet	\$1,500*
10 Gig Ethernet and up	\$1,500
Nx10Gig Ethernet	\$3,500

\* Pricing also applies to Service locations in Alaska.

**Table 4: LAN IP Block Size**

IPv4 LAN IP Block Size	Undiscounted MRC	Discount
/28	\$112	100.00%
/27	\$224	100.00%
/26	\$448	100.00%
/25	\$896	100.00%
/24	\$1,792	100.00%
/23	\$3,584	100.00%
/22	\$7,168	100.00%
/21	\$14,336	100.00%
/20	\$28,672	100.00%
/19	\$57,344	100.00%

**AT&T and Customer Confidential Information**

Page 3 of 14

ASAP!

**AT&T DEDICATED INTERNET  
 PRICING SCHEDULE**

**Table 5: Flexible Bandwidth Billing Option – Ethernet\***

Discount applied to ADI & ADI w/Managed Router Discount: 0.00% This discount applies to all Tiered Bandwidth Minimum Commitments in this table unless an override discount is indicated.			Incremental Usage Fee Discount: 97.00% This discount applies to all Tiered Bandwidth Minimum Commitments in this table unless an override discount is indicated.
Tiered Bandwidth Minimum Commitment	ADI Undiscounted Monthly Fee	ADI with Managed Router Undiscounted Monthly Fee	Undiscounted Incremental Usage Fee Per Mbps
<b>Discount applied to ADI &amp; ADI w/ Managed Router for the following: 83.50%</b>			<b>Incremental Usage Fee Discount for the following:</b>
0.5 Mbps	\$257	\$385	\$940
1.0 Mbps	\$258	\$386	\$510
1.5 Mbps	\$259	\$387	\$380
2 Mbps	\$260	\$388	\$355
3 Mbps	\$261	\$389	\$340
4 Mbps	\$262	\$390	\$325
5 Mbps	\$263	\$391	\$270
6 Mbps	\$264	\$392	\$250
7 Mbps	\$265	\$393	\$245
8 Mbps	\$266	\$394	\$235
9 Mbps	\$267	\$395	\$230
<b>Discount applied to ADI &amp; ADI w/ Managed Router for the following: 83.50%</b>			<b>Incremental Usage Fee Discount for the following:</b>
10 Mbps	\$268	\$396	\$198
15 Mbps	\$359	\$487	\$162.33
20 Mbps	\$449	\$577	\$144.25
25 Mbps	\$542	\$670	\$134.00
<b>Discount applied to ADI &amp; ADI w/ Managed Router for the following: 85.00%</b>			<b>Incremental Usage Fee Discount for the following:</b>
30 Mbps	\$633	\$761	\$126.83
35 Mbps	\$680	\$854	\$122.00
40 Mbps	\$812	\$945	\$118.13
45 Mbps	\$817	\$950	\$105.56
<b>Discount applied to ADI &amp; ADI w/ Managed Router for the following: 92.00%</b>			<b>Incremental Usage Fee Discount for the following:</b>
50 Mbps	\$813	\$955	\$95.50
60 Mbps	\$946	\$1,100	\$91.67
70 Mbps	\$1,032	\$1,200	\$85.71
75 Mbps	\$1,118	\$1,300	\$86.67
80 Mbps	\$1,204	\$1,420	\$88.75
90 Mbps	\$1,290	\$1,500	\$83.33
<b>Discount applied to ADI &amp; ADI w/ Managed Router for the following: 93.00%</b>			<b>Incremental Usage Fee Discount for the following:</b>
100 Mbps	\$1,400	\$1,555	\$77.75
120 Mbps	\$1,770	\$1,937	\$80.71
144 Mbps	\$1,790	\$1,960	\$68.06
150 Mbps	\$1,800	\$1,965	\$65.50
155 Mbps	\$1,820	\$2,020	\$65.16
<b>Discount applied to ADI &amp; ADI w/ Managed Router for the following: 91.00%</b>			<b>Incremental Usage Fee Discount for the following:</b>
200 Mbps	\$2,000	\$2,100	\$52.50
250 Mbps	\$2,150	\$2,240	\$44.80
300 Mbps	\$2,250	\$2,620	\$43.67

AT&T and Customer Confidential Information

Page 4 of 14  
 ASAP!

**AT&T DEDICATED INTERNET  
 PRICING SCHEDULE**

<b>Discount applied to ADI &amp; ADI w/Managed Router Discount: 0.00%</b> This discount applies to all Tiered Bandwidth Minimum Commitments in this table unless an override discount is indicated.			<b>Incremental Usage Fee Discount: 97.00%</b> This discount applies to all Tiered Bandwidth Minimum Commitments in this table unless an override discount is indicated.
Tiered Bandwidth Minimum Commitment	ADI Undiscounted Monthly Fee	ADI with Managed Router Undiscounted Monthly Fee	Undiscounted Incremental Usage Fee Per Mbps
<b>Discount applied to ADI &amp; ADI w/ Managed Router for the following: 83.50%</b>			<b>Incremental Usage Fee Discount for the following:</b>
350 Mbps	\$2,500	\$3,125	\$44.64
<b>Discount applied to ADI &amp; ADI w/ Managed Router for the following: 94.00%</b>			<b>Incremental Usage Fee Discount for the following:</b>
400 Mbps	\$2,700	\$3,380	\$42.25
450 Mbps	\$3,000	\$3,720	\$41.33
500 Mbps	\$3,500	\$4,325	\$43.25
550 Mbps	\$3,650	\$4,425	\$40.23
600 Mbps	\$4,096	\$4,840	\$40.33
622 Mbps	\$4,117	\$5,000	\$40.19
<b>Discount applied to ADI &amp; ADI w/ Managed Router for the following: 92.00%</b>			<b>Incremental Usage Fee Discount for the following:</b>
700 Mbps	\$4,199	\$5,240	\$37.43
800 Mbps	\$4,301	\$5,440	\$34.00
900 Mbps	\$4,403	\$5,540	\$30.78
1000 Mbps	\$4,505	\$5,620	\$28.10

\* Pricing also applies to Service locations in Alaska (Override discounts are not applicable to Service locations in Alaska).

**Table 6: Flexible Bandwidth Billing Option – ADI 10 Gig Ethernet\*\***

<b>ADI &amp; ADI w/Managed Router Discount:0.00%</b> Applies to all Tiered Bandwidth Minimum Commitments in this table unless an override discount is indicated.			<b>Incremental Usage Fee Discount: 97.00%</b> Applies to all Tiered Bandwidth Minimum Commitments in this table unless an override discount is indicated.
Tiered Bandwidth Minimum Commitment	ADI Undiscounted Monthly Fee	ADI with Managed Router Undiscounted Monthly Fee	Undiscounted Incremental Usage Fee
<b>Discount applied to ADI for the following: 94.00%</b>			<b>Incremental Usage Fee Discount for the following:</b>
.5 Gbps	\$5,658	\$7,000	\$70.00
1.0 Gbps	\$6,400	\$9,950	\$49.75
<b>Discount applied to ADI for the following: 95.00%</b>			<b>Incremental Usage Fee Discount for the following:</b>
1.5 Gbps	\$8,727	\$10,909	\$36.36
2.0 Gbps	\$9,091	\$12,276	\$30.69
2.5 Gbps	\$11,244	\$15,215	\$30.43
<b>Discount applied to ADI for the following: 94.50%</b>			<b>Incremental Usage Fee Discount for the following:</b>
3.0 Gbps	\$13,309	\$17,981	\$29.97
3.5 Gbps	\$14,400	\$19,462	\$27.80
4.0 Gbps	\$16,015	\$21,591	\$26.99
<b>Discount applied to ADI for the following: 94.50%</b>			<b>Incremental Usage Fee Discount for the following:</b>
4.5 Gbps	\$16,771	\$22,720	\$25.24
5.0 Gbps	\$18,196	\$24,553	\$24.55

AT&T and Customer Confidential Information

Page 5 of 14  
 ASAP!

**AT&T DEDICATED INTERNET  
 PRICING SCHEDULE**

<b>ADI &amp; ADI w/Managed Router Discount:0.00%</b> Applies to all Tiered Bandwidth Minimum Commitments in this table unless an override discount is indicated.			<b>Incremental Usage Fee Discount: 97.00%</b> Applies to all Tiered Bandwidth Minimum Commitments in this table unless an override discount is indicated.
<b>Tiered Bandwidth Minimum Commitment</b>	<b>ADI Undiscounted Monthly Fee</b>	<b>ADI with Managed Router Undiscounted Monthly Fee</b>	<b>Undiscounted Incremental Usage Fee</b>
<b>Discount applied to ADI for the following: 94.00%</b>			<b>Incremental Usage Fee Discount for the following:</b>
5.5 Gbps	\$19,636	\$26,502	\$24.09
6.0 Gbps	\$21,309	\$28,768	\$23.97
<b>Discount applied to ADI for the following: 94.00%</b>			<b>Incremental Usage Fee Discount for the following:</b>
6.5 Gbps	\$22,589	\$30,499	\$23.46
7.0 Gbps	\$24,218	\$32,727	\$23.38
7.5 Gbps	\$25,760	\$34,793	\$23.20
8.0 Gbps	\$26,953	\$36,387	\$22.74
<b>Discount applied to ADI for the following: 94.00%</b>			<b>Incremental Usage Fee Discount for the following:</b>
8.5 Gbps	\$28,233	\$38,115	\$22.42
9.0 Gbps	\$28,931	\$39,069	\$21.71
9.5 Gbps	\$29,527	\$39,855	\$20.98
10.0 Gbps	\$30,909	\$41,716	\$20.86

\* Service not available with MPLS PNT.

# Pricing also applies to Service locations in Alaska (Override discounts are not applicable to Service locations in Alaska).

**Table 7: Class of Service Option - Tiered T-1, T-3 and Burstable Service - Monthly Service Fees**

**Discount: 100.00%**

<b>Speed</b>	<b>Class of Service Monthly Fee – List Price** (w/ or w/out Managed Router)</b>
56 Kbps**	\$225
128 Kbps**	\$225
256 Kbps**	\$225
384 Kbps**	\$225
512 Kbps**	\$225
768 Kbps	\$225
1024 Kbps**†	\$225
1.5 Mbps	\$225
2xT-1 (3 Mbps)	\$225
3xT-1 (4.5 Mbps)	\$225
4xT-1 (6 Mbps)	\$225
5xT-1 (7.5 Mbps)	\$225
6xT-1 (9 Mbps)	\$225
7xT-1 (10.5 Mbps)	\$225
8xT-1 (12 Mbps)	\$225
10 Mbps	\$825
15 Mbps	\$1,075
20 Mbps	\$1,325
25 Mbps	\$1,575
30 Mbps	\$1,825

**AT&T and Customer Confidential Information**

Page 6 of 14  
 ASAP!

**AT&T DEDICATED INTERNET  
 PRICING SCHEDULE**

Speed	Class of Service Monthly Fee – List Price** (w/ or w/out Managed Router
35 Mbps	\$2,100
40 Mbps	\$2,350
45 Mbps	\$2,750
155 Mbps	\$2,750

\* Charges waived for Sites with AT&T BVoIP Service.

\*\*no real-time class available.

(†) Speed not available with MPLS PNT.

# Pricing also applies to Service locations in Alaska.

**Table 8: Class of Service Option - Flexible Bandwidth Billing Option - Monthly Service Fees**

Discount: 100.00%

Speed	Undiscounted ADI w/ or w/out Managed Router Monthly Service Fee**
Up to 1.5 Mbps	\$225
2.0 Mbps	\$285
2.01 - 3.0 Mbps	\$360
3.01 - 4.0 Mbps	\$435
4.01 - 5.0 Mbps	\$510
5.01 - 6.0 Mbps	\$575
6.01 - 7.0 Mbps	\$640
7.01 - 8.0 Mbps	\$705
8.01 - 9.0 Mbps	\$765
9.01 to 10.0 Mbps	\$825
10.01 to 15.0 Mbps	\$1,075
15.01 - 20.0 Mbps	\$1,325
20.01 - 25.0 Mbps	\$1,575
25.01 - 30.0 Mbps	\$1,825
30.01 - 35.0 Mbps	\$2,100
35.01 - 40.0 Mbps	\$2,350
40.01 – 45 Mbps	\$2,750
45.01 – 155 Mbps	\$5,000
200 - 250 Mbps	\$5,400
300 - 350 Mbps	\$5,800
400 - 600 Mbps	\$6,200
622 Mbps	\$7,000
700 – 1000 Mbps	\$7,800
1.5 Gbps**	\$7,900
2.0 Gbps**	\$8,000
2.5 Gbps**	\$8,100
3.0 Gbps**	\$8,200
3.5 Gbps**	\$8,300
4.0 Gbps**	\$8,400
4.5 Gbps**	\$8,500
5.0 Gbps**	\$8,600
5.5 Gbps**	\$8,700
6.0 Gbps**	\$8,800
6.5 Gbps**	\$8,900

**AT&T and Customer Confidential Information**

Page 7 of 14  
 ASAP!

**AT&T DEDICATED INTERNET  
PRICING SCHEDULE**

Speed	Undiscounted ADI w/ or w/out Managed Router Monthly Service Fee**
7.0 Gbps**	\$9,000
7.5 Gbps**	\$9,100
8.0 Gbps**	\$9,200
8.5 Gbps**	\$9,300
9.0 Gbps**	\$9,400
9.5 Gbps**	\$9,500
10.0 Gbps and up**	\$9,600

\*Charges waived for Sites with AT&amp;T BVoIP Service.

\*\* Speed not available with MPLS PNT.

# Pricing also applies to Service locations in Alaska.

**Table 9: Class of Service Option – Aggregate Billing Option\*\* - Monthly Service Fees**

Discount: 100.00%

Speed	Undiscounted ADI w/ or w/out Managed Router Monthly Service Fee**
T3 (up to 45 Mbps)	\$2,750
OC3 (up to 155 Mbps)	\$5,000
OC12 (up to 622 Mbps)	\$7,000
Ethernet (up to 1000 Mbps)	\$7,800
OC48 (up to 2500 Mbps)	\$8,100
10 Gigabit Ethernet (up to 10000 Mbps) and up	\$9,600

\*Charges waived for Sites with AT&amp;T BVoIP Service.

\*\*Not available with MPLS PNT.

**Table 10: Local Access without Diversity**

Address	City	State	Zip	Access Bandwidth	Local Access Non-Recurring Charge	Local Access Net Monthly Recurring Charge
6950 N East Prairie Road	Lincolnwood	IL	60712	MIS Ethernet Access 1 Gbps	\$0.00	\$550.00

**Section II: AT&T Business in a Box<sup>SM</sup>****Table 1: Service Component Replacement – Next Business Day Shipped (5x8) Monthly Charges**

Discount: 100.00%

Service Component / Device	Undiscounted MRC*
Base Unit NextGen	\$50
Base Unit 12 Port	\$70
Base Unit 24 Port	\$30
Base Unit High Bandwidth	\$75
8 Port Analog Module Add-On	\$35

\* Pricing also applies to Service locations in Alaska

**AT&T and Customer Confidential Information**Page 8 of 14  
ASAP!

**AT&T DEDICATED INTERNET  
 PRICING SCHEDULE**

**Table 2: On-Site Maintenance (24X7X4) Monthly Charges**

**Discount: 100.00%**

Option	Undiscounted MRC*
Base Unit NextGen	\$75
Base Unit 12 Port	\$95
Base Unit 24 Port	\$35
Base Unit High Bandwidth	\$85
8 Port Analog Module Add-On	\$40

\* Pricing also applies to Service locations in Alaska

**Table 3: Life-Cycle Management Charges - Service Charges**

**Discount: 100.00%**

Per Site / Per Occurrence during Standard Business Hours (Monday-Friday, 8:00 am- 5:00 pm, local time)	Undiscounted Service Charge List Price *
Additional Service	\$260
Delete Service	\$500

\* Pricing also applies to Service locations in Alaska.

**Table 4: Class of Service Option - when ordered with AT&T BVoIP Services only**

**Discount: 100.0%**

Class of Service Monthly Service Fee	\$225*
--------------------------------------	--------

\* Pricing also applies to Service locations in Alaska.

**Table 5: IP Version Change**

**Discount: 100.00%**

IP Version Change – Per Site, Per Occurrence	\$500*
--	--------

\* Pricing also applies to Service locations in Alaska.

**Section III: Additional Service Fees**

Moving Fee (during hours)	\$1,000 per location*
Additional Moving Fee (outside standard operating hours – 8:00 a.m. to 5:00 p.m. Monday through Friday)	Additional \$500 per location*

\*Subject to availability, pricing also applies to Service locations in Alaska  
 This is the last page of the Pricing Document.

**AT&T and Customer Confidential Information**

Page 9 of 14  
 ASAP!



## E-rate Rider

### ATTACHMENT TO AT&T DEDICATED INTERNET ("Agreement") FOR SERVICES AND/OR PRODUCTS SUBJECT TO UNIVERSAL SERVICES ("E-RATE") FUNDING

This Attachment ("Attachment") is entered into by AT&T Corp. ("AT&T") and LINCOLNWOOD SCHOOLS (Customer) and is effective as of the date last signed below (Effective Date). It is an attachment to the Agreement and has the same term as the Agreement. If there are any inconsistencies between the Agreement and this Attachment with respect to the Service for which E-rate funding is sought, the terms and conditions of this Attachment control..

#### TERMS AND CONDITIONS APPLICABLE TO E-RATE FUNDED PRODUCTS AND SERVICES

**Customer intends to seek funding through the E-rate program for Services purchased under the Agreement. E-rate is administered by the Universal Service Fund Administrative Company (USAC). The Federal Communications Commission (FCC) has promulgated regulations that govern the participation in the E-rate program. The Parties agree::**

1. Eligibility of Products and Services. The eligibility or ineligibility of products or services for E-rate funding is solely determined by USAC and/or the FCC. AT&T makes no representations or warranties regarding such eligibility.
2. Service Substitutions USAC funding commitments are based upon the products, services and locations set forth in the Form 471. Any modification to the products and services or the locations at which they are to be installed or provided requires Customer to file a service substitution with USAC. AT&T may suspend Service substitution activities pending approval of service substitution requests.
3. Requested Information. If requested, Customer will promptly provide AT&T with final copies of the following E-rate-related materials (including all attachments): (i) Form 471 and Bulk Upload template(s); (ii) Form 486; (iii) Form 500; (iv) Service Substitution Request; (v) Service Certification Form; and (vi) Form 472-BEAR. If the Customer issues purchase orders, Customer will clearly delineate between eligible and non-eligible Services on those orders.
4. Indemnities. Each party agrees it has and will comply with all laws and requirements applicable to the E-rate Program. In addition to any indemnification obligations set forth in the Agreement and to the extent permitted by law, each party agrees to indemnify and hold harmless the other party (its employees, officers, directors and agents, and its parents and affiliates under common control) from and against all third party, FCC or USAC claims and related loss, liability, damage, and expense (including reasonable attorney's fees) arising out of the indemnifying party's violation of the E-rate rules or breach of the terms of this Attachment.
5. Non-Appropriations. By executing the Agreement, Customer confirms that it has funds appropriated and available to pay all amounts due for E-rate supported Services through the end of it's current fiscal period. Customer further agrees to request all appropriations and funding necessary to pay for the Services for each subsequent fiscal period through the end of the Agreement Term. In the event Customer is unable to obtain the necessary appropriations for the Services provided under this Attachment, Customer may terminate the Services without liability for the termination charges upon the following conditions: (i) Customer has taken all actions necessary to obtain adequate appropriations; (ii) despite Customer's best efforts funds have not been appropriated and are otherwise unavailable to pay for the Services; and (iii) Customer has negotiated in good faith a revised agreement with AT&T to develop revised services and terms to accommodate Customer's budget. Customer must provide AT&T thirty (30) days' written notice of its intent to terminate the Services. Termination of the Services for failure to obtain necessary appropriations shall be effective as of the last day for which funds were appropriated or otherwise made available. If Customer terminates the Services under this Attachment, Customer agrees as follows: (i) it will pay all amounts due for Services incurred through date of termination, and reimburse all unrecovered non-recurring charges; and (ii) it will not contract with any other provider for the same or substantially similar services or equipment for a period equal to the original Agreement term. This section 5 applies to Customer funding appropriations, and does not allow for termination if E-rate funding is denied or delayed.

#### 6. Customer Must Choose A or B

- A.)  [OPTION "A" IS AVAILABLE FOR NEW OR EXISTING SERVICES]

#### CONFIDENTIAL INFORMATION

*This agreement is for use by the authorized employees of the parties hereto only and is not for general distribution within or outside the companies.*



## E-rate Rider

**CUSTOMER DIRECTS AT&T TO COMMENCE OR CONTINUE SERVICES EVEN IF E-RATE FUNDING HAS NOT BEEN APPROVED BY USAC. CUSTOMER ACKNOWLEDGES ITS OBLIGATION TO PAY FOR THE SERVICE IF FUNDING IS DENIED OR DELAYED.**

(i). Scope: **Customer desires that Services commence on or about July 1 unless a different date is inserted here 07-01-2024** .. AT&T will make reasonable efforts to meet the requested date, but AT&T does not commit to commence Service by the requested date. The term of the Services begins on the Start Date of Minimum Payment Period as provided in the applicable Pricing Schedule, or if there is no Pricing Schedule then as may be stated in the applicable Order document.

(ii). Funding Denial Agreement Termination: CUSTOMER ACKNOWLEDGES THAT THERE IS NO RIGHT TO TERMINATE THE SERVICES OR SERVICE COMPONENTS MADE THE BASIS OF THIS ATTACHMENT IF E-RATE FUNDING IS DELAYED OR DENIED.

B.)  [OPTION "B" IS APPROPRIATE FOR NEW SERVICES]

**SERVICES WILL NOT COMMENCE AND EQUIPMENT WILL NOT SHIP UNTIL AT&T RECEIVES NOTIFICATION THAT E-RATE FUNDS HAVE BEEN COMMITTED; IF E-RATE FUNDING FOR SERVICES OR EQUIPMENT IS DENIED, THE AGREEMENT WILL TERMINATE AS TO THOSE SERVICES OR EQUIPMENT UNLESS A NEW ATTACHMENT (REPLACING THIS ATTACHMENT) IS EXECUTED.**

(i). Scope: Customer agrees to use best efforts to obtain funding from USAC. AT&T will not begin work related to the Services and/or equipment (including, without limitation, construction, installation or activation activities) until after AT&T receives Customer notification to proceed with the order, and verification of funding approval, and, for Internal Connections, a verification of Form 486 approval by USAC. AT&T will commence Service(s) as soon as is practical following the receipt of the appropriate documentation. The Services term begins on installation and delivery of those services, and will continue for the term stated in the Agreement.

(ii). Funding Denial Agreement Termination: if a funding request is denied by USAC, the Agreement, with respect to such Service(s) and/or equipment, will terminate sixty (60) days from the date of the FCDL in which E-rate funding is denied or on the 30th day following rejection of the final appeal of such denial, and Customer will not incur termination liability. In the event Services and/or equipment are to be provided pursuant to a multi-year arrangement (whether by contract or tariff), this termination right applies only to the first year of the multi-year agreement. This provision does not apply to Services that were initially approved for funding and subsequently deemed ineligible by USAC after commencement of Service..

(iii). IF CUSTOMER WISHES TO CHANGE ITS SELECTION AND WISHES AT&T TO COMMENCE SERVICES REGARDLESS OF FUNDING COMMITMENT FROM USAC, CUSTOMER WILL EXECUTE A NEW (REPLACEMENT) ATTACHMENT, AND AGREE TO THE TERMS SET FORTH IN "A" ABOVE.

#### 7. AT&T Owned Equipment - General Terms and Conditions.

If the Services require placing Equipment (e.g. routers, switches) on the Customer's premises (the "Premises") Customer does not wish to provide this Equipment itself, but instead requests the placement of the Equipment as part of the installation of the underlying Service. Neither the Agreement nor this Attachment includes an option to purchase the Equipment. Customer will not use the Equipment for any purpose other than receipt of the eligible Service of which it is a part.

A. Accordingly, Customer hereby:

- Grants AT&T a license to install, operate, and maintain the Equipment and any additional, supplemental or replacement equipment as AT&T may choose.
- Confirms this license includes a right of access to and within the Premises for purposes of installing, operating, maintaining, repairing and replacing the Equipment. All Equipment brought onto the premises by AT&T is the personal property of AT&T (regardless of whether such Equipment is attached or affixed to the Premises) and Customer has no right to, interest in, or exclusive use of that Equipment.

**CONFIDENTIAL INFORMATION**

*This agreement is for use by the authorized employees of the parties hereto only and is not for general distribution within or outside the companies.*

2 of 14



### E-rate Rider

- Agrees to provide adequate space and electric power for the Equipment and keep the Equipment physically secure and free from liens and encumbrances. Customer bears the risk of loss or damage to the Equipment (other than ordinary wear and tear), except to the extent caused by AT&T or its agents.
- Agrees to notify AT&T of any issues related to the Equipment, including the need for maintenance or repair, and assumes responsibility for notifying any other contractors or persons with a need to know of the presence and location of the Equipment.
- Agrees to indemnify and hold AT&T harmless from any and all liability that may arise out of the presence and placement of the Equipment, except for AT&T's gross negligence.
- Grants AT&T the right, but not the obligation, to remove all or any part of the Equipment from the premises at any time after the termination of the Service.

Additionally, E-rate program rules and eligibility requirements apply, and these requirements may change from time to time.

#### 8. Terms of Equipment Usage

Please note that there are some important Customer obligations to facilitate timely Equipment installation and service delivery. Accordingly, Customer agrees to provide the following:

A. **PATH** - The Customer is responsible for providing or causing the property owner to provide a path from the property line into the building. A clear underground or aerial path is required from the property line where AT&T ILEC facilities exist, to the equipment room designated to support the entrance fiber.

B. **SPACE** – Customer is responsible for providing appropriate floor space and a properly installed equipment rack of suitable strength and quality to properly support the intended Equipment at the Minimum Point of Entry (MPOE)/ Demarcation Point in compliance with FCC and AT&T service requirements.

The appropriate space and location will be mutually agreed following an AT&T site visit. Any Demarcation Point location which is further than the closest practicable point to the MPOE in the building will require custom work which may not be eligible for E-rate Category 1 funding, and must be paid for by the Customer.

C. **ENVIRONMENTAL** – Operating environment should be between +40° F and 100° F at 0% to 85% relative humidity (RH-Non-Condensing).

D. **POWER - GROUND** - Customer will provide:

- Permanent, dedicated, 3-prong grounded power for the Equipment being installed. Power requirements can consist of nominal –48VDC, +24/-24 VDC, 110V, 125V, 220V, etc. located within 3 feet of the AT&T Equipment. AT&T may require more than one power outlet for some Equipment types, and there are specific amperage requirements for different Equipment types.
- Relay racks/cabinets must be properly grounded by placing an exposed #6 or larger grounding wire to the building's ground source. This ground wire will be attached to the closest ground rod (earth ground) or building bus bar available and run to the Network Terminating Equipment location in the room.

Any other site-specific customer obligations will also be provided by AT&T personnel via e-mail upon finalization of this Attachment.

#### 9. Customer Premise Support Structure ("CPSS") - General Terms and Conditions

If the Services require placing conduit and/or other conduit pathway support structures (Facilities) on the Customer's Premises. Customer does not wish to provide these Facilities itself, but instead requests the placement of the Facilities as part of the construction and installation work of the underlying Service.

Accordingly, Customer hereby:

- Grants AT&T a license to install and operate the Facilities and any replacement Facilities as AT&T may choose.
- Confirms such license includes a right of access to and within the Premises for purposes of installing, repairing and replacing the Facilities. All Facilities brought onto the Premises by AT&T, once installed and functional, become Customer property.

#### **CONFIDENTIAL INFORMATION**

*This agreement is for use by the authorized employees of the parties hereto only and is not for general distribution within or outside the companies.*



### E-rate Rider

- Confirms that once the Facilities are installed, the Customer is responsible for the cost of any installation, maintenance, repair or replacement of the Facilities.
- Assumes responsibility for notifying any other contractors or persons with a need to know of the presence and location of the Facilities.

#### **Additional Terms Applicable to Customers using CALNET Agreements and with the following CALNET services:**

- **CALNET 3 Extension Agreements:** IFB STPD 12-001-A, C3-A-12-10-TS-01 – Amendment 13 and IFB STPD 12-001-B, C3-B-12-10-TS-01 Amendment 12 are anticipated to expire on 12/31/21. Notwithstanding anything to the contrary, upon the expiration of these Agreements, the Customer will take such reasonable steps as may be necessary to continue to procure the same or substantially similar services hereunder pursuant to the State of California – Statewide Technology Procurement - AT&T - IFB C4DNCS19 (“CALNET NEXTGen Contract”), to the extent such service(s) is/are available. Upon such migration of service, the term "Agreement" as used herein shall refer to the CALNET NEXTGen Contract.
- **Metropolitan Area Network (MAN) Ethernet (3.0):** In the event of termination of service within 24 months from the Cutover Date of Service, Customer is liable for 100% of the cost of \$9200 for each site at which AT&T installs CPSS.
- **Managed Internet Services (5.0):** If Customer cancels Service at an eligible Customer site prior to the service activation date, AT&T is not obligated to complete work on Entrance Facility Construction (EFC), and Customer agrees to compensate AT&T for all of AT&T's costs incurred through the date of cancellation associated with providing EFC, regardless of whether the construction has been completed.

#### **10. USAC Invoicing Method**

AT&T will follow invoicing requirements and accommodates either the Service Provider Invoice Form (SPI) - Form 474 – or the Billed Entity Application Reimbursement (“BEAR”) - Form 472 invoice method. Customer agrees to promptly submit any AT&T or USAC Forms needed to support requests for payment for Services rendered.

- SPI – Customer must first receive an approved Funding Commitment Decision Letter and Form 486 Notification Letter. In addition, the Customer agrees NO LATER THAN 120 days prior to their Last Date to Invoice to notify AT&T of its SPI election, and to provide and certify to AT&T an accurate list of the applicable Billing Accounts Numbers for services per their Form 471 funding application for each Funding Request Number for which the SPI method is sought. Customer agrees that invoices are due and payable in full by their stated due date unless these requirements have been met and SPI discounts commence. Where these requirements are not met, Customer agrees to utilize the BEAR disbursement method to request their E-rate funding. See: <http://usac.org/sl/applicants/step06/default.aspx>.
- BEAR - Under current rules, Service Providers have no involvement in the BEAR invoice process.

#### **11. Reimbursement of USAC**

Customer agrees to promptly submit any AT&T or USAC forms needed to support Form 474 SPI requests for payment of discounted Services. If USAC (i) seeks recovery from AT&T for disbursed E-rate funds as a result of Customer's failure to comply with the E-rate rules, including Customer delays in submitting required forms or contracts; or (ii) determines that Services which it had previously been approved for discounts are not eligible resulting in a “Notice of Improperly Disbursed Funds” or other request for recovery of funds (other than as the result of AT&T's failure to comply with the E-rate rules), then AT&T will reverse any E-rate SPI discounts provided which were denied, any reimbursements demanded, and any funds returned, and Customer will (a) pay all unfunded, reimbursed, or returned amounts and (b) reimburse AT&T for any funds AT&T must return to USAC, each within ninety (90) days of notice from USAC. In addition, Customer agrees and acknowledges that a determination of ineligibility, reduction, or other non-funding by USAC does not affect the obligations set forth in the Agreement, including those obligations related to payments and early termination fees. This provision shall supersede any other provision with respect to limits on the time period in which charges may be invoiced.

#### **12. Contract Requirements**

**FCC RULES REQUIRE THAT PRIOR TO SUBMISSION OF A FORM 471 APPLICATION FOR FUNDING THE PARTIES MUST HAVE ENTERED INTO A BINDING CONTRACT FOR THE SERVICES MADE THE SUBJECT OF THE APPLICATION. IT IS THE CUSTOMER'S RESPONSIBILITY TO ENSURE THAT STATE LAW REQUIREMENTS FOR A BINDING CONTRACT HAVE BEEN MET PRIOR TO THE SUBMISSION OF A FORM 471.**

- IF THIS BOX IS CHECKED, THIS ATTACHMENT REPLACES THE ATTACHMENT BETWEEN THE PARTIES DATED 07-01-2024

#### **CONFIDENTIAL INFORMATION**

*This agreement is for use by the authorized employees of the parties hereto only and is not for general distribution within or outside the companies.*



**E-rate Rider**

SO AGREED by the Parties' respective authorized signatories:

<b>Customer</b> (by its authorized representative)	<b>AT&amp;T</b> (by its authorized representative)
By:	By:
Name:	Name:
Title:	Title:
Date :	Date:

**CONFIDENTIAL INFORMATION**

*This agreement is for use by the authorized employees of the parties hereto only and is not for general distribution within or outside the companies.*

Agreement between Lincolnwood School District 74  
and  
AT&T

March 13, 2024

AT&T  
1876 Data Dr.  
Hoover, AL 35244

Re: Erate Contract Award Notification

Dear Ms. Sulprizio,

This letter will confirm our decision to enter into a 24-month contract for 1 Gbps ADI Service with an MRC of \$999.60 during the next E-rate funding year (07/01/2024 to 06/30/2026) as specified in the attached contract.

The execution of the attached contract will be dependent upon the following conditions:

- 1.  X  Board approval of contract on May 2, 2024
- 2.  X  Terms and conditions are acceptable
- 3.  X  Terms of Contract: 7/1/2024 – 6/30/2026

To accept these terms and conditions, please sign below and return via email to at

We look forward to working with AT&T.

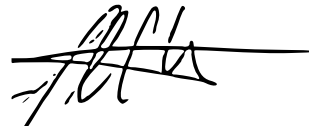

3/13/24

\_\_\_\_\_  
Jordan Stephen  
Director of Technology  
Lincolnwood School District 74

\_\_\_\_\_  
Date

Vendor Agreement:

*Veronica Danao*  
\_\_\_\_\_  
22 Mar 2024

AT&T  
\_\_\_\_\_  
Date

Veronica Danao  
Contractor Contract Specialist, as Signer for AT&T

**Exhibits –  
Contract Draft  
Pending Board Approval**

# E-Rate Proposal for Lincolnwood School District 74



To:  
Jordan Stephen  
Lincolnwood School District 74  
6950 N East Prairie Rd  
Lincolnwood, IL 60712

From:  
Dana Sulprizio, AT&T E-Rate Sales  
Office: 205-517-4474  
Email: ds9454@att.com

## Introduction

In response to **Lincolnwood School District 74's** Form 470 bid #**240003415**, I'm providing information on an AT&T solution that may meet your requirements and qualify for E-Rate funding. The solution includes the following components:

- **AT&T Dedicated Internet** is an internet access service that combines a dedicated connection with symmetrical bandwidth (same download and upload speeds) and provides reliable, high-performance connectivity. AT&T Dedicated Internet offers the fastest speeds available (up to 1Tbps), world class Service Level Agreements (SLAs) with 100% uptime guarantees, and outage protection down to the customer edge router with 24/7 monitoring.

## Features and Benefits

The solution gives you the following:

- **ADI with Managed Router Option**—provides the customer premises equipment (CPE) for ADI, generally a router and a diagnostic modem. AT&T configures, monitors, manages, and maintains the equipment. You provide a dedicated standard telephone line for out-of-band testing of the diagnostic modem. This option provides convenient end-to-end managed internet access so you can focus on your core mission.
- **Customer-Managed Router Option** lets you provide and manage your own router for the dedicated internet service while AT&T provides the managed internet access. So, you have flexibility to choose the level of service you need.
- **Reliable Service**—starts with proactive monitoring of our nationwide backbone along with a network architecture that features redundant routers, switches, and power supplies. As a result, we can reroute traffic around outages and restore service almost instantaneously. This increases reliability and helps ensure that your internet traffic gets through. In addition, you get enterprise-class support, with 24/7 expert technical assistance.
- **AT&T Business Center Portal** provides a suite of online tools to access billing, maintenance, network management, and performance reporting information and functions. Business Center tools let you view and manage various aspects of your AT&T service 24/7 via a convenient online portal.
- **Cyber Threat Analysis** provides real time information so you can immediately determine the category, volume, and severity of detected threats. As an additional intelligence layer, these reports also identify sites visited by Acceptable Use Policies (AUP) category so you can better understand policies required to prevent traffic directed to unwanted risky site categories. This feature available in your Business Portal can help you make informed security decisions for your business at no extra charge.

## Advantages of AT&T

Working with AT&T gives you the following advantages:

- **E-Rate Experience**—AT&T has participated in the E-Rate program for schools and libraries since the program's inception in 1998, and we're one of the program's largest service providers. We're proud to bring our technology, expertise, E-Rate knowledge, and education experience to your school or library, helping expand affordable access to advanced telecommunication services. For more information about AT&T and its participation in the E-Rate program, go to [www.corp.att.com/erate](http://www.corp.att.com/erate).
- **Service and Support**—We offer you easy access to assistance, whether through online tools or by phone. You also get support and guidance from highly trained staff with years of networking experience. Our account teams, who work closely with you, are focused on the education industry and are well versed in the issues and challenges that today's educators face.
- **Performance**—You expect communication services that work, and we can deliver. We've made substantial investments each year to improve our technology infrastructure so that we can provide superior performance.
- **Complete Solutions**—AT&T offers a wide range of solutions. We can work with a variety of products and technologies and can assess your needs to recommend potential solutions.
- **Community Focus**—At AT&T, we're proud of our strong record of corporate citizenship. Annually, we contribute millions of dollars through corporate, foundation, and employee giving to support education and community programs.



*We're investing in connectivity and technology, digital literacy, and digital learning solutions to help connect today's learners with success—in and out of the classroom. It's part of our \$2 billion commitment to help bridge the digital divide. Learn more at [att.com/connectedlearning](http://att.com/connectedlearning).*

## Solution Pricing

**Pricing for AT&T Dedicated Internet (ADI) is based on the following term: 12, 24, and 36 month terms.**

Note: MRC = monthly recurring charge and NRC = non-recurring charge. Rates do not include Fees, Surcharges or Taxes. All rates and components are 100% E-Rate eligible.

**We are submitting our proposal based on this address ONLY. Please let us know if this is not the correct/only address - ASAP! Additional sites may qualify for this pricing pending further fiber availability review.**

6950 N East Prairie Road, Lincolnwood, IL 60712

There are no Special Construction Charges if installed at this address.

### ADI 1YR Rates - SPIN 143001192 AT&T Corp.

Access Speed	Access Monthly	Port Speed	Port Monthly w/AT&T Managed Router **	Total MRC*	NRC
1 GB	\$550.00	1 GB	\$3,934.00	\$4,484.00	\$0.00
10 GB	\$1,100.00	2 GB	\$5,524.20	\$6,624.20	\$0.00
10 GB	\$1,100.00	3 GB	\$8,091.45	\$9,191.45	\$0.00
10 GB	\$1,100.00	5 GB	\$11,048.85	\$12,148.85	\$0.00

\*Price is per circuit. \*\* Pricing for circuits without an AT&T Managed Router available upon request.

### ADI 2YR and 3YR Rates - SPIN 143001192 AT&T Corp.

Access Speed	Access Monthly	Port Speed	Port Monthly w/AT&T Managed Router **	Total MRC*	NRC
1 GB	\$550.00	1 GB	\$449.60	\$999.60	\$0.00
10 GB	\$1,100.00	2 GB	\$613.80	\$1,713.80	\$0.00
10 GB	\$1,100.00	3 GB	\$988.96	\$2,088.96	\$0.00
10 GB	\$1,100.00	5 GB	\$1,350.42	\$2,450.42	\$0.00

\*Price is per circuit. \*\* Pricing for circuits without an AT&T Managed Router available upon request.

Currently the Federal Access Recovery Fee (FARF) is set at .7% of the Access MRC. Property Tax Allotment (PTA) currently set at \$13.99 may apply. FARF and PTA rates are subject to change.

This solution includes the Ethernet access circuit, AT&T Managed Internet Service, AT&T owned and managed Router and AT&T technician installation. At speeds greater than 100Mbps, an optical interface (1000Base-SX multi-mode or 1000Base-LX single mode) or a 10GigE interface is required. AT&T Technician onsite installation, setup and testing of the managed router is provided at no cost. AT&T personnel unpack, mount, connect, configure, and test the managed router. AT&T installation is required for all optical interfaces.

Should conduit be required on your property to facilitate fiber installation, AT&T will provide up to 1000ft. of conduit at no cost. *(Not valid on new construction.)*

The customer is responsible for the provisioning and monthly cost of one phone line for management and remote troubleshooting when using an AT&T Managed Router. Without which will render the SLAs null and void. *AT&T is not making any determinations, representations, or warranties regarding the E-Rate eligibility of these additional products and services. The eligibility of these products and services for E-Rate funding is solely determined by USAC and/or the FCC based on the applicants E-Rate discount request.*

Static IP addresses are provided by AT&T Internet.

**This response to your request is not a contract offer and does not take the place of a signed contract.** If you select AT&T for this service, please let us know so we can provide you the appropriate contract documents. Neither party is obligated for the selected services unless and until mutually agreed contract documents are signed by both parties. The Pricing proposed herein is based upon the specific product/service mix and locations outlined in this proposal and assumes use of AT&T contract documents and an E-Rate Rider as part of any final, negotiated contract between the parties, unless otherwise stated herein. Any changes or variations in the proposed terms and conditions, the products/services, length of term, locations, and/or design described herein may result in different pricing. Prices quoted do not include applicable taxes, surcharges, or fees. In accordance with the tariffs or other applicable service agreement terms, Customer is responsible for payment of such charges.

## Optional Services

AT&T is presenting this additional product information to alert you to other important services that can be very useful to **Lincolnwood School District 74's** educational goals and overall security concerns. These services are optional and are not contingent on the purchase of any E-Rate eligible services from AT&T.

**PLEASE NOTE:** AT&T is not making any determinations, representations, or warranties regarding the E-Rate eligibility of these additional products and services. The eligibility of these products and services for E-Rate funding is solely determined by USAC and/or the FCC based on the applicants E-Rate discount request. Among the products and services are

- **Wireless/Wireline Voice Services**
  - **Mobile data<sup>1</sup> plans** can help your staff stay connected. AT&T ranked best and most reliable 5G network and best network overall in Global Wireless Solutions' (GWS) 2021 OneScore survey<sup>2</sup>. Check the coverage in your area at [www.att.com/maps/wireless-coverage](http://www.att.com/maps/wireless-coverage).
  - **Wireline voice services** can expand the capabilities of your AT&T Dedicated Internet (ADI) access—add Voice over IP with AT&T IP Flexible Reach service ([Video: IP Flexible Reach: A Simplified Voice and Data Service](#)).
- **FirstNet** wireless services are designed to improve public safety communications, coordination, and response times, leading to safer and more secure communities. This can be crucial during times of crisis. For more information, visit [www.firstnet.com](http://www.firstnet.com).
- **AT&T Cybersecurity** can help protect your network from constantly evolving threats. Our cybersecurity professionals have helped schools and districts with limited IT resources get the security features they need at a price that meets their budget. To learn more about our security services portfolio, visit [cybersecurity.att.com](http://cybersecurity.att.com) or call 650.713.3333.

---

<sup>1</sup> Mobile Data plans may be eligible for E-Rate program support only in instances when the School or Library seeking support demonstrates to the USAC that they are the most cost-effective option for providing internet access based on an Applicant's request for E-Rate discounts. AT&T makes no determinations, representations, or warranties regarding such eligibility.

<sup>2</sup> GWS conducts paid drive tests for AT&T and uses the data in its OneScore analysis. AT&T 5G requires compatible plan and device. 5G not available everywhere. Go to [att.com/5Gforyou](http://att.com/5Gforyou) for details

## Important Information

For ADI with Managed Router, the customer is responsible for the provisioning and monthly cost of one phone line for management and troubleshooting of the managed service and router.

AT&T may provide Entrance Facility Construction (EFC) for eligible customers, as explained in the Entrance Facility Construction section of the AT&T Business Service Guide General Provisions. Customers who do not qualify for AT&T EFC are responsible for providing the conduit/structure as well as the path from the property line to the demarcation point for access to the primary route.

**Proposal Validity Period**—The information and pricing contained in this Proposal is valid for a period of 90 days from the date written on the proposal cover page, or until the E-Rate filing window closes for the upcoming E-Rate Funding year, whichever occurs later, unless rescinded or extended in writing by AT&T.

**Proposal Pricing**—Pricing proposed herein is based upon the specific product/service/equipment mix and locations outlined in this proposal and is subject to AT&T's proposed terms and conditions for those products and services and the AT&T E-Rate Rider unless otherwise stated herein. Any changes or variations in the proposed terms and conditions, the products/services, length of term, locations, and/or design described herein may result in different pricing. Prices quoted do not include applicable taxes, surcharges, or fees. In accordance with the tariffs or other applicable service agreement terms, Customer is responsible for payment of such charges.

**Providers of Service**—Subsidiaries and affiliates of AT&T Inc. provide products and services under the AT&T brand.

**Software**—Any software used with the products and services provided in connection with this Proposal will be governed by the written terms and conditions applicable to such software. Title to software remains with AT&T or its supplier. Customer must comply with all such terms and conditions, and they will take precedence over any agreement between the parties as relates to such software.

**Disclaimer**—For purposes of this Proposal, the identification of certain services as "eligible" or "non-eligible" for E-Rate funding is not dispositive, nor does it guarantee that this or any other services in this Proposal will be deemed eligible for such funding. Any conclusions regarding the eligibility of services for E-Rate funding must be based on several factors, many of which have yet to be determined relative to the proposed services and equipment described herein. Such factors will include, without limitation, the ultimate design configuration of the network, the specific products and services provisioned to operate the network, the type of customer, and whether the services are used for eligible educational purposes at eligible locations. In its proposal, AT&T will take guidance from the "Eligible Services List" and the specific sections on product and service eligibility on the Universal Service Administrative Company ("USAC") website [www.usac.org/e-rate](http://www.usac.org/e-rate). This site provides a current listing of eligible products and services, as well as conditionally eligible and ineligible services. This guidance notwithstanding, the final determination of eligibility will be made by the USAC after a review of the customer's E-Rate application for this proposal. If AT&T is awarded the bid for this project, AT&T will provide assistance on the E-Rate application solely on matters relative to the functionality of the services and products which comprise the network. Nevertheless, the responsibility for the E-Rate application is with the customer. AT&T is not responsible for the outcome of the USAC's decision on these matters.

**End User Equipment**—E-Rate recipients must cost allocate any non-ancillary ineligible components that are bundled with eligible products or services. Cost allocations are the responsibility of E-Rate Applicants. For additional information, reference USAC website @ [www.usac.org/e-rate](http://www.usac.org/e-rate) and Cost Allocation Guidelines for Services @ [www.usac.org/e-rate/applicant-process/before-you-begin/eligible-services-overview/cost-allocations-for-services/](http://www.usac.org/e-rate/applicant-process/before-you-begin/eligible-services-overview/cost-allocations-for-services/).

**Copyright Notice and Statement of Confidentiality**—© 2023 AT&T Intellectual Property. AT&T and globe logo are registered trademarks and service marks of AT&T Intellectual Property and/or AT&T affiliated companies. All other marks are the property of their respective owners. The contents of the Proposal (except for pricing applicable to E-Rate funded services) are unpublished, proprietary, and confidential and may not be copied, disclosed, or used, in whole or in part, without the express written permission of AT&T Intellectual Property or affiliated companies, except to the extent required by law and insofar as is reasonably necessary in order to review and evaluate the information contained herein.



## Executive Summary Finance Committee Meeting

---

DATE: April 18th, 2024

TOPIC: District Purchasing Update(s)

PREPARED BY: David Russo, Dominick Lupo, Jordan Stephen

### Recommended for:

- Action
- Discussion
- Information

### Purpose/Background:

This document provides the Finance Committee with an update of ongoing District renewals and/or purchases that will not require Board Approval based on criteria adopted in May 2023.

### Items for Finance Committee Review:

- Gaggle for 2024-2025
  - Gaggle provides archiving services for all staff members using SD74.org domain emails, past and present.
  - The District worked with the vendor to clean out our Google domains and insure that Gaggle was archiving our accounts correctly.
  - \$3,510.00 - The District paid \$3,505.00 for the same services for the 23-24 school year.
- Jamf for 2024-2025
  - Jamf provides Mobile Device Management (MDM) services for all District iPads.
  - The Jamf MDM service schedules software updates, pushes approved applications to student iPads, and creates profiles for students and devices to allow them to be used with the classroom and off campus.
  - By removing certain feature sets that are not in use, the District has reduced the yearly expense of this product.
  - \$8,250.00 - The District paid \$13,509.00 for the services during the 23-24 school year.

- Formative for 2024-2025
  - Formative is a cloud-based assessment platform that provides feedback and keeps students engaged, accountable in both virtual and traditional classrooms.
  - Formative provides teachers with real-time information on student work and allows for immediate intervention and support.
  - \$3,517.80 - The District paid \$3,515.89 for the services during the 23-24 school year.
  
- Pebble Go for 2024-2025
  - PebbleGo is a curricular content hub specifically designed for K-2 students.
  - This service contains informational articles, ready-made activities, and literacy supports for students of all abilities It boosts engagement and fosters independent learning in core subject areas.
  - This product has been in use for many years at Todd Hall and fits the needs of K-2 learners.
  - \$1,197.00 - The District paid \$1,197.00 for the services during the 23-24 school year.

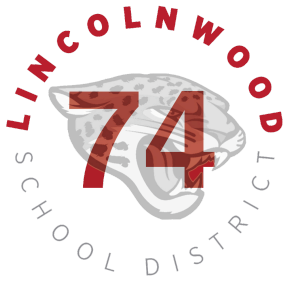

## Finance Committee Meeting

DATE: April 18, 2024

TOPIC: District Finance Update

PREPARED BY: Courtney Whited

**Recommended for:**

Action

Discussion

Information

**Purpose/Background:**

To provide the Finance Committee an update on ongoing District-wide matter(s):

1. Potential partnership between SD74 and the Early Childhood Alliance