

Board of Education Special Meeting

Wednesday, May 3, 2023

6:00 PM

High School Computer Lab Room 204

358 North 6th Street

Tecumseh, NE 68450

1. Board of Education/Superintendent Workshop
2. Call to Order/Roll Call
3. Agenda-Business
 - 3.1. Discuss, consider and take any necessary action in regards to a Bond Resolution.
4. Next Meeting
5. Adjourn



 **SITE LAYOUT PLAN**
SCALE: 1" = 60'-0"

JCCPS Expansion

Tecumseh, NE

CE No.: 316-001-19

March 17, 2023

DRAFT
PREPARED FOR PRELIMINARY
SUBMISSION AND REVIEW ONLY --
NOT FOR CONSTRUCTION.

Site Layout Plan

L2.01

LOWER LEVEL

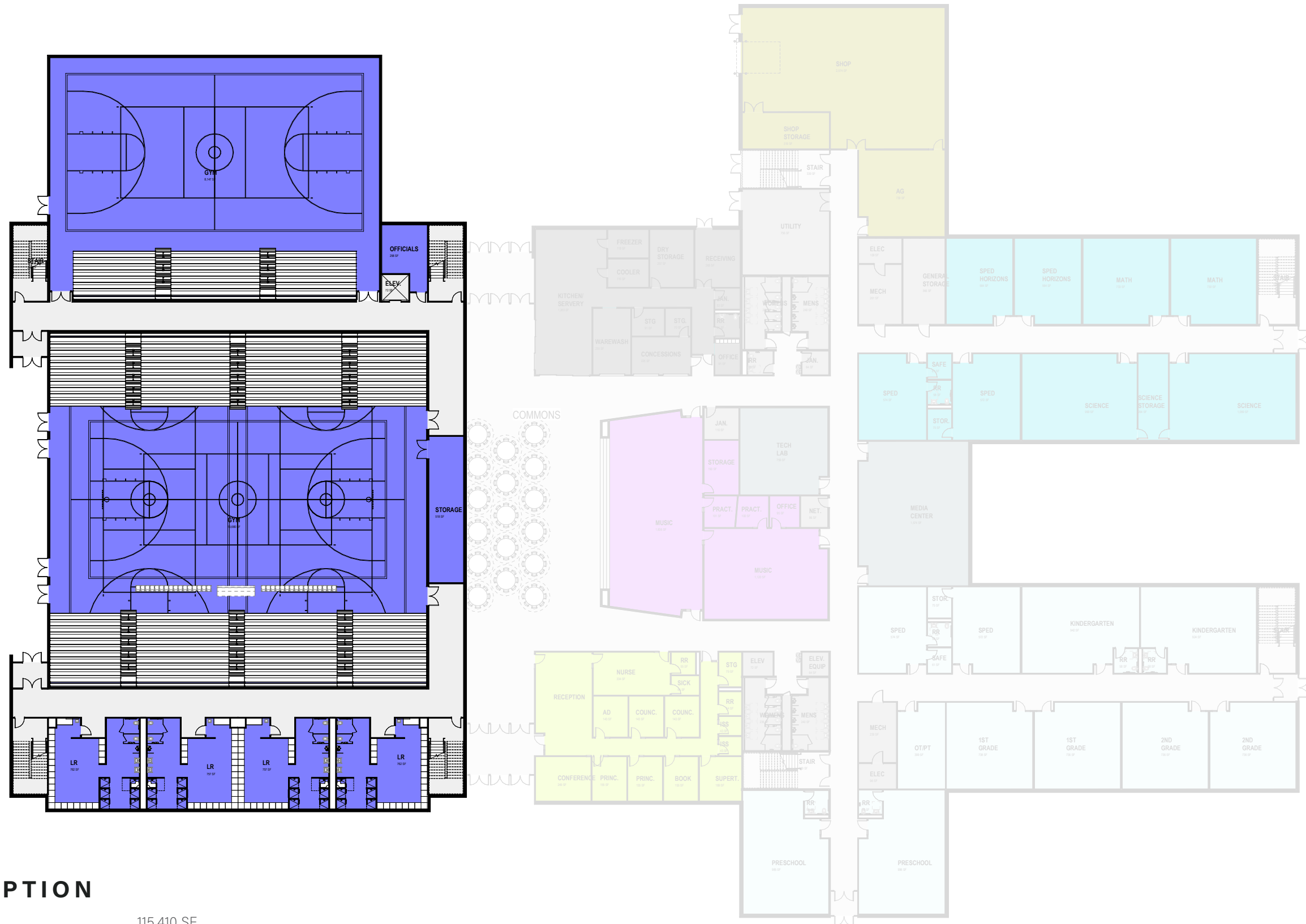

TOP LOAD GYM OPTION

K-12 + Main Gym (does not include aux gym) 115,410 SF
 Auxiliary Gym 8,530 SF

Full Build 123,940 SF

Johnson County Central Public School
 March 16, 2023

- Food Service
- Building Support
- Circulation
- Athletics
- Administration
- High School Classrooms
- SPED
- Elementary Classrooms
- Performing Arts
- AG/IT/Art

FIRST FLOOR

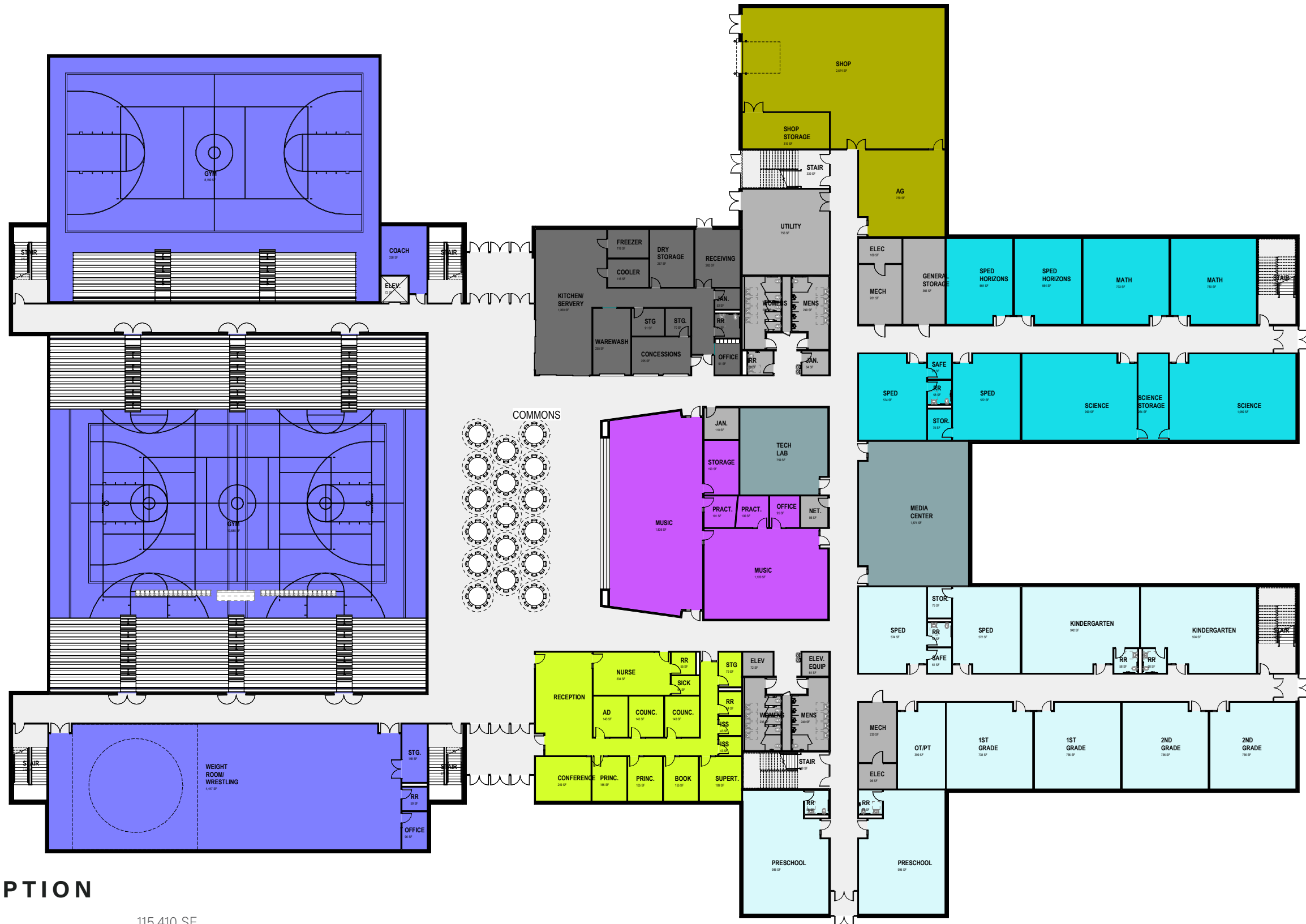

TOP LOAD GYM OPTION

K-12 + Main Gym (does not include aux gym)	115,410 SF
Auxiliary Gym	8,530 SF
Full Build	123,940 SF

Johnson County Central Public School
March 16, 2023

- Food Service
- Building Support
- Circulation
- Athletics
- Administration
- High School Classrooms
- SPED
- Elementary Classrooms
- Performing Arts
- AG/IT/Art

SECOND FLOOR



TOP LOAD GYM OPTION

K-12 + Main Gym (does not include aux gym) 115,410 SF
 Auxiliary Gym 8,530 SF

Full Build 123,940 SF

Johnson County Central Public School
 March 16, 2023

- Food Service
- High School Classrooms
- Building Support
- SPED
- Circulation
- Elementary Classrooms
- Athletics
- Performing Arts
- Administration
- AG/IT/Art

CONCEPT MASSING

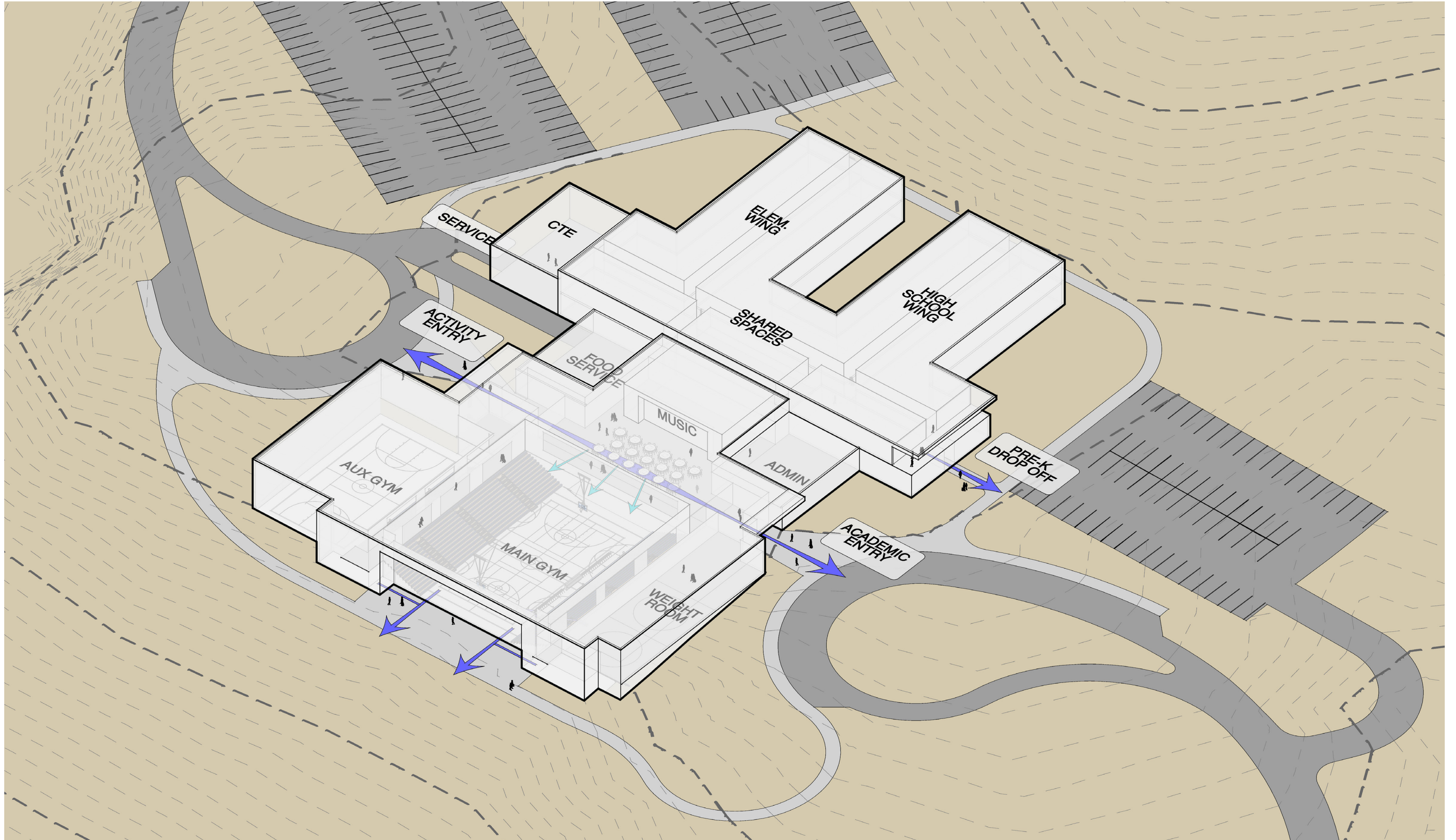

CONSTRUCTION TYPE COMPARISON

WALL ASSEMBLIES

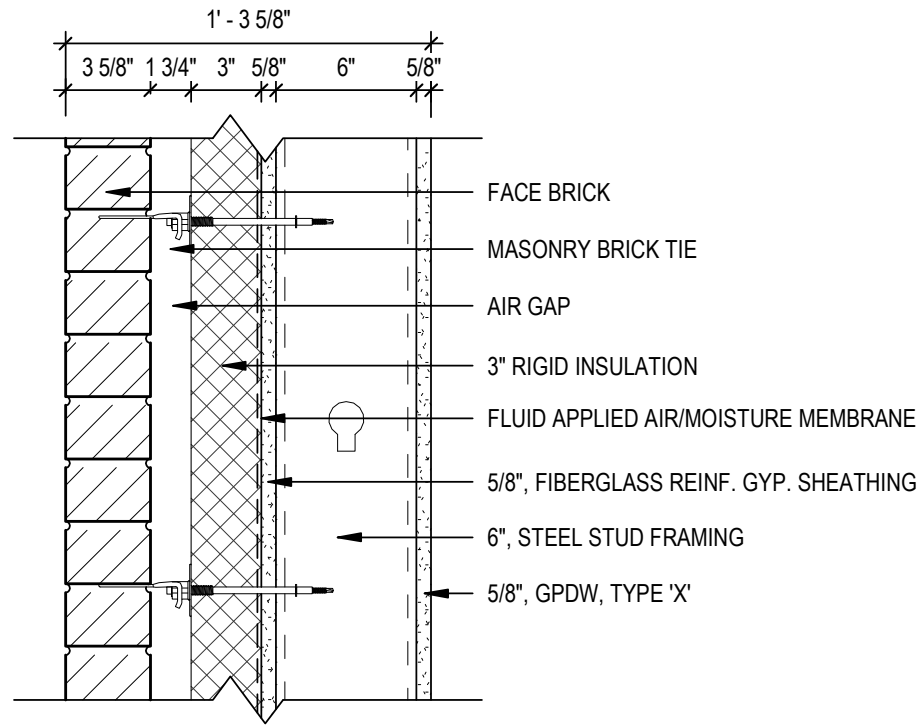

BRICK ON METAL STUD

MASONRY CLADDING - RIGID POLY-ISO. INSULATION

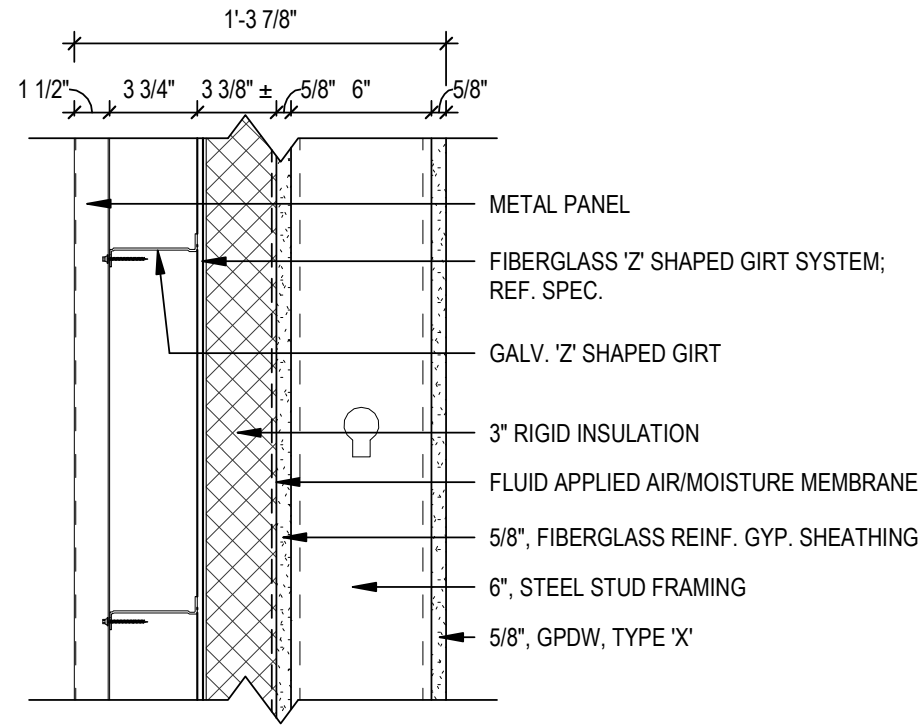

METAL PANEL ON METAL STUD

METAL PANEL CLADDING - RIGID INSULATION

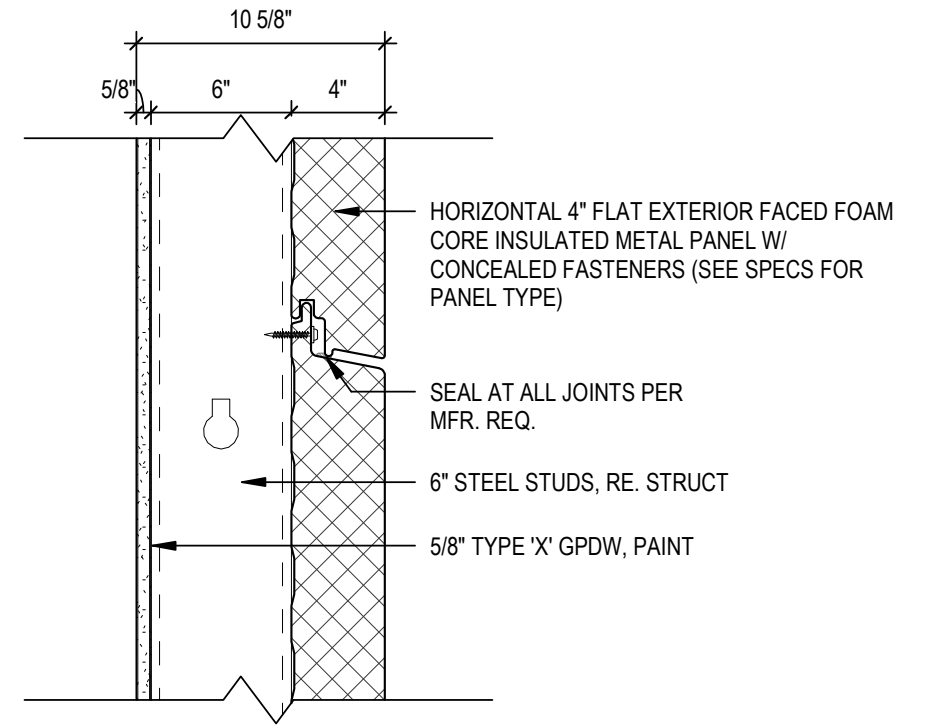

INSULATED METAL PANEL ON METAL STUD

4" INSULATED METAL WALL PANEL

ROOF ASSEMBLIES

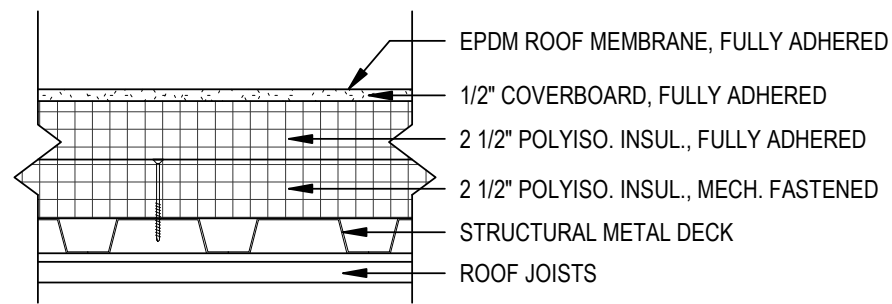

EPDM ON METAL DECK

BASE INSULATION - RIGID INSULATION

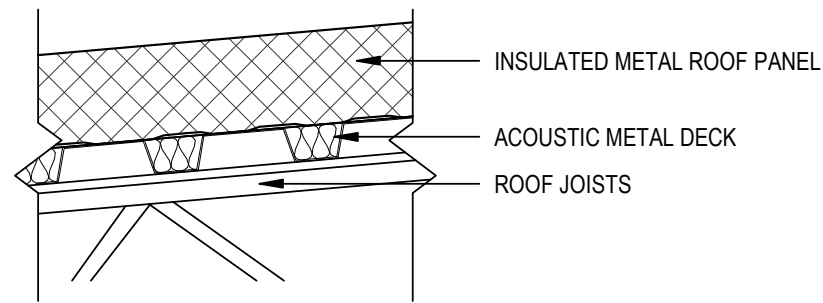

INSULATED METAL PANEL ON ACOUSTIC DECK

4" INSULATED METAL ROOF PANEL

CROSS SECTION CONSIDERATION - ATHLETICS

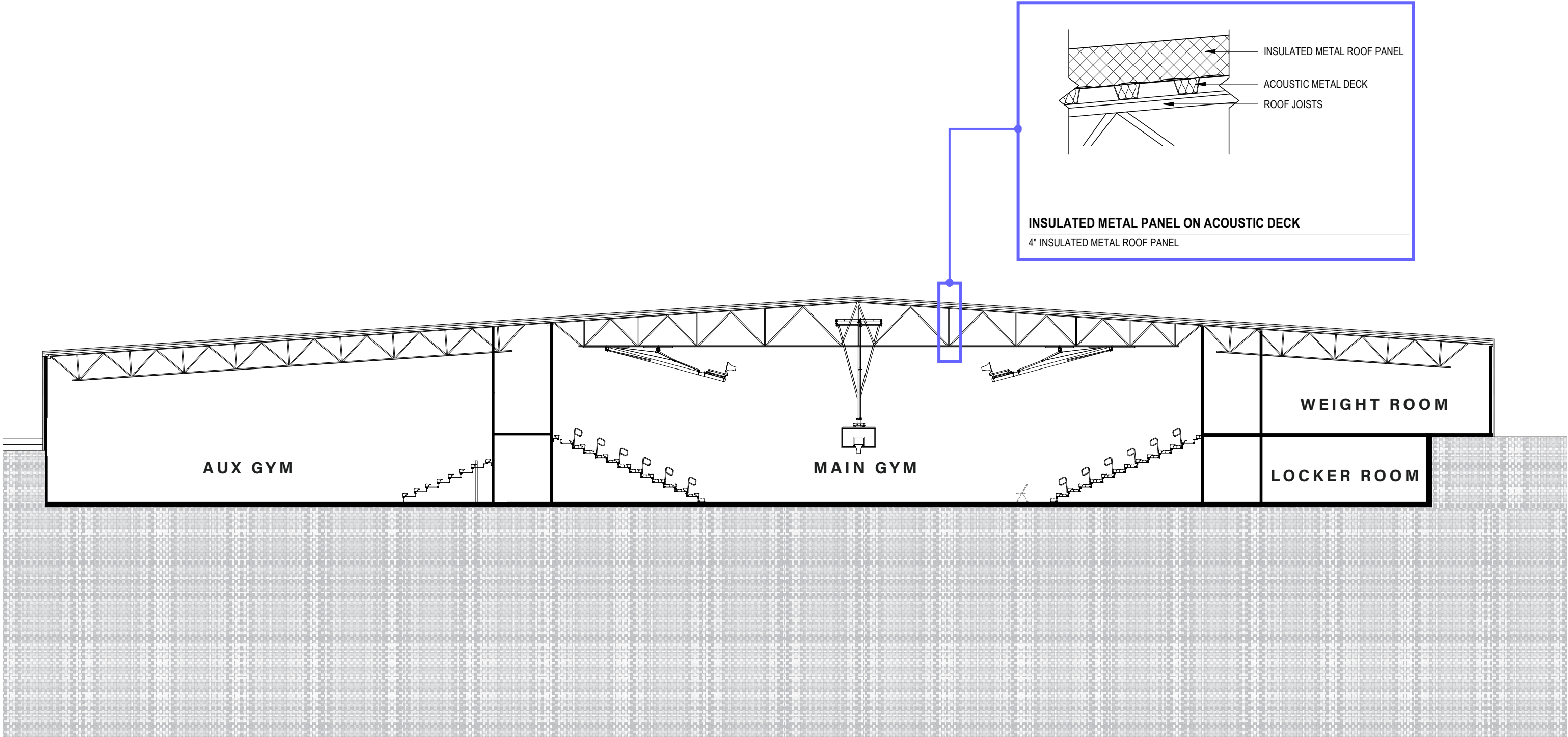

RESOLUTION

A RESOLUTION CALLING A SPECIAL ELECTION IN JOHNSON COUNTY SCHOOL DISTRICT 0050 (JOHNSON COUNTY CENTRAL PUBLIC SCHOOLS) IN THE STATE OF NEBRASKA; AND RELATED MATTERS

BE IT RESOLVED BY THE BOARD OF EDUCATION OF JOHNSON COUNTY SCHOOL DISTRICT 0050 (JOHNSON COUNTY CENTRAL PUBLIC SCHOOLS) IN THE STATE OF NEBRASKA:

Section 1. The Board of Education (the “**Board**”) of Johnson County School District 0050 (Johnson County Central Public Schools) in the State of Nebraska (the “**District**”) hereby finds and determines as follows:

(a) The District is a duly organized school district under Nebraska law that maintains both elementary and high school grades under the direction of a single board of education.

(b) It is necessary that funds be provided for the purpose of paying the costs of [land acquisition and the construction and acquisition of pre-kindergarten to 12th grade facilities for the District; and providing for the necessary furniture, equipment and apparatus for such facilities] (the “**Project**”).

(c) To pay the costs of the Project, it will be necessary for the District to issue general obligation bonds of the District in an aggregate stated principal amount not to exceed Forty-seven Million Dollars (\$47,000,000).

(d) No proposition for the issuance of bonds for any such purposes has been submitted to the electors of the District within six months preceding the date of the special election called by this Resolution.

Section 2. A special election (the “**Election**”) is hereby called and shall be held in the District on July 11, 2023, (the “**Election Date**”) at which Election there shall be submitted to the qualified electors of the District the following proposition (the “**Proposition**”):

“Shall Johnson County School District 0050 (Johnson County Central Public Schools), in the State of Nebraska, issue the Bonds of said District in the principal amount not to exceed Forty-seven Million Dollars (\$47,000,000) for the purpose of paying costs of [land acquisition and the construction and acquisition of pre-kindergarten to 12th grade facilities for the District; and providing for the necessary furniture, equipment and apparatus for such facilities]; said bonds to be issued in one or more series, at such time or times as may be determined by the Board of Education, to bear interest at such rate or rates as may be determined by the Board of Education and to become due at such time or times as may be fixed by the Board of Education; and

Shall the School District cause to be levied and collected annually a special levy of taxes against all the taxable property in the School District sufficient in rate and amount to pay the interest on and principal of said Bonds as the same become due?”

The ballots to be voted on and cast at the Election shall have printed thereon the foregoing Proposition, with the words “Yes, for such Bonds and tax” and “No, against such Bonds and tax” following the Proposition.

Qualified electors voting in favor of the Proposition shall blacken the oval opposite the words “FOR such Bonds and tax” following the Proposition, and qualified electors voting against the Proposition shall blacken the oval opposite the words “AGAINST such Bonds and tax” following the Proposition.

Section 3. Notice of the Election shall be published in the *Tecumseh Chieftain* at least 42 days prior to the Election Date by the Election Commissioner of Johnson County, Nebraska (the “**Election Commissioner**”). Notice of the Election shall also be given to the qualified electors of the District 20 days prior to the Election and a copy of the sample ballot shall be published one time not more than ten days nor less than three days prior to the Election, or as otherwise provided by law, such notice and sample ballot to be published in the *Tecumseh Chieftain*, a newspaper of general circulation in the District, and the Secretary be and hereby is directed to cause such notice and sample ballot to be published.

Section 4. The Secretary is hereby authorized and directed to certify a copy of this Resolution not later than May 19, 2023 (which is the eighth Friday preceding July 11, 2023) to the Election Commissioner, who shall designate the polling places (if applicable), appoint the election officials and otherwise conduct the Election as provided by law. The District hereby agrees to reimburse the Election Commissioner for the expenses of conducting the Election.

Section 5. The form of ballot and form of notice for such bond election shall be in substantially the form attached to this Resolution as **Attachment I**, utilizing the appropriate provisions for an election held by mail or at polling places and with such other additions and changes determined appropriate by the Election Commissioner. The Secretary of the Board is hereby authorized and directed in conjunction with the Election Commissioner conducting the Election, to arrange for the printing of the necessary ballots for the Election and to do all other things and to take all other appropriate or necessary action in order to cause the Proposition to be submitted to the qualified electors of the District as above provided.

Section 6. Anything to the contrary herein notwithstanding, the President and Secretary of the Board are hereby authorized and directed to (a) cause the form of ballot and form of notice approved herein and attached hereto as **Attachment I** to be published in accordance with such laws, with such changes therein as the President or Secretary of the Board, in consultation with counsel to the District and bond counsel, deem necessary to conform to such laws, and (b) take all further actions necessary to comply with all publication and filing deadlines and other election procedures and requirements as may be necessary or proper to submit the Proposition described in **Section 2** hereof to the qualified electors of the District on the Election Date.

Section 7. This Resolution shall take effect and be in force from and after its passage as provided by law.

PASSED: May 10, 2023.

**JOHNSON COUNTY SCHOOL DISTRICT
0050 (JOHNSON COUNTY CENTRAL PUBLIC
SCHOOLS) IN THE STATE OF NEBRASKA**

ATTEST:

By: _____
President

By: _____
Secretary

OFFICIAL BALLOT

SCHOOL BOND ELECTION
JOHNSON COUNTY SCHOOL DISTRICT 0050
(JOHNSON COUNTY CENTRAL PUBLIC SCHOOLS)
IN THE STATE OF NEBRASKA

Tuesday, July 11, 2023

“Shall Johnson County School District 0050 (Johnson County Central Public Schools), in the State of Nebraska, issue the Bonds of said District in the principal amount not to exceed Forty-seven Million Dollars (\$47,000,000) for the purpose of paying costs of [land acquisition and the construction and acquisition of pre-kindergarten to 12th grade facilities for the District; and providing for the necessary furniture, equipment and apparatus for such facilities]; said bonds to be issued in one or more series, at such time or times as may be determined by the Board of Education, to bear interest at such rate or rates as may be determined by the Board of Education and to become due at such time or times as may be fixed by the Board of Education; and

Shall the School District cause to be levied and collected annually a special levy of taxes against all the taxable property in the School District sufficient in rate and amount to pay the interest on and principal of said Bonds as the same become due?”

- Yes, for such Bonds and tax
- No, against such Bonds and tax

Electors voting in favor of such proposition shall blacken the oval opposite the words “Yes, for such Bonds and tax” following such proposition, and electors voting against such proposition shall blacken the oval opposite the words “No, against such Bonds and tax” following the proposition.

NOTE: PUBLISH 1 TIME before election (after June 25, 2023, but before July 9, 2023)

NOTICE OF SCHOOL BOND ELECTION

**JOHNSON COUNTY SCHOOL DISTRICT 0050
(JOHNSON COUNTY CENTRAL PUBLIC SCHOOLS)
IN THE STATE OF NEBRASKA**

Tuesday, July 11, 2023

PUBLIC NOTICE is hereby given to the qualified electors of Johnson County School District 0050 (Johnson County Central Public Schools) in the State of Nebraska (the “**District**”) that a special election has been called and will be held in the District on Tuesday, July 11, 2023, at which time there shall be submitted to the qualified electors of the District the following proposition:

“Shall Johnson County School District 0050 (Johnson County Central Public Schools), in the State of Nebraska, issue the Bonds of said District in the principal amount not to exceed Forty-seven Million Dollars (\$47,000,000) for the purpose of paying costs of [land acquisition and the construction and acquisition of pre-kindergarten to 12th grade facilities for the District; and providing for the necessary furniture, equipment and apparatus for such facilities]; said bonds to be issued in one or more series, at such time or times as may be determined by the Board of Education, to bear interest at such rate or rates as may be determined by the Board of Education and to become due at such time or times as may be fixed by the Board of Education; and

Shall the School District cause to be levied and collected annually a special levy of taxes against all the taxable property in the School District sufficient in rate and amount to pay the interest on and principal of said Bonds as the same become due?”

- Yes, for such Bonds and tax
- No, against such Bonds and tax

Electors voting in favor of such proposition shall blacken the oval opposite the words “Yes, for such Bonds and tax” following such proposition, and electors voting against such proposition shall blacken the oval opposite the words “No, against such Bonds and tax” following such proposition.

[Election Commissioner to determine whether election will be held by mail or at polling places and include appropriate provisions for the chosen election method below]

Polling Place Election

[Insert provisions if the election is to be held at polling places]

By Mail Election

This election will be an election by mail. All registered voters residing within Johnson County School District 0050 (Johnson County Central Public Schools) will receive their ballot by mail and therefore no polling places will be open for voting. Ballots will be mailed by the Election Commissioner of Johnson County no sooner than June 19, 2023 and no later than July 1, 2023.

Voter Registration Deadlines

The deadline to register to vote at an agency, with a deputy registrar, by mail or delivered by an agent is June 23, 2023. The deadline for in-person registration is June 30, 2023, at the Johnson County Election Commissioner’s Office located at 351 Broadway Street, Tecumseh, Nebraska 68450, PO Box 416. Any voter who changes information on a current registration or registers to vote after the ballots have been mailed but before the in-person registration deadline of June 30, 2023, by 5:00 p.m., will be given a ballot at the time of registration or change.

Ballot Return Deadline

Voted ballots must be delivered in person or by an agent to the Johnson County Election Commissioner’s Office at 351 Broadway Street, Tecumseh, Nebraska 68450, PO Box 416, and must be received no later than 5:00 p.m. on Tuesday, July 11, 2023.

BY ORDER OF THE BOARD OF EDUCATION
OF JOHNSON COUNTY SCHOOL DISTRICT
0050 (JOHNSON COUNTY CENTRAL PUBLIC
SCHOOLS) IN THE STATE OF NEBRASKA

NOTE TO COUNTY ELECTION COMMISSIONER: PUBLISH no less than 42 days prior to election:

On or before May 30, 2023

NOTE TO SCHOOL DISTRICT: PUBLISH weekly for 4 consecutive weeks immediately preceding the election:

Suggested Publication Dates:

June 15, 2023

June 22, 2023

June 29, 2023

July 6, 2023

Delete Edit Article Change Media Back

Johnson County Central

District News

Upcoming Bond Building Plans – A Brief Overview

May 02, 2023

The images below are current plans for a potential future JCC school on the proposed site (which is approximately 50 acres of farm ground Northeast of the football field at the Tecumseh site). The plans work from East to West on the proposed site with the first (easternmost) image being the highest in elevation. As the building plans move Westward, the elevation drops with each image. Therefore, the building will have three levels; a top level of classrooms, a middle level of class-rooms, commons and top load gym, and a lower level being the gym floor and auxiliary gym. The final image is the “site plan” showing how the building will sit on the property.

The goal of the project is to provide the necessary square footage for all the programming needs of our district. Therefore, some of the spaces, walls and formatting could change throughout the design and even building phases. However, the square footage would remain approximately the same. The facility presented here includes ALL programming for JCC’s needs. The current Cook Site, Tecumseh Site Elementary and High School would no longer be needed.

The dollar figure for the facility, all aspects of the work, dirt work, utilities, soft costs and FFE (furniture, fixtures & equipment) is in the range of \$47-\$50 million.

The images below should provide a higher-resolution of the building & plans compared to the Monthly Newsletter. But if you would like a PDF view, please click on the link below:

[PDF view of the 2023 Proposed Bond](#) (PDF)

2023 Proposed Bond Site Layout Plan

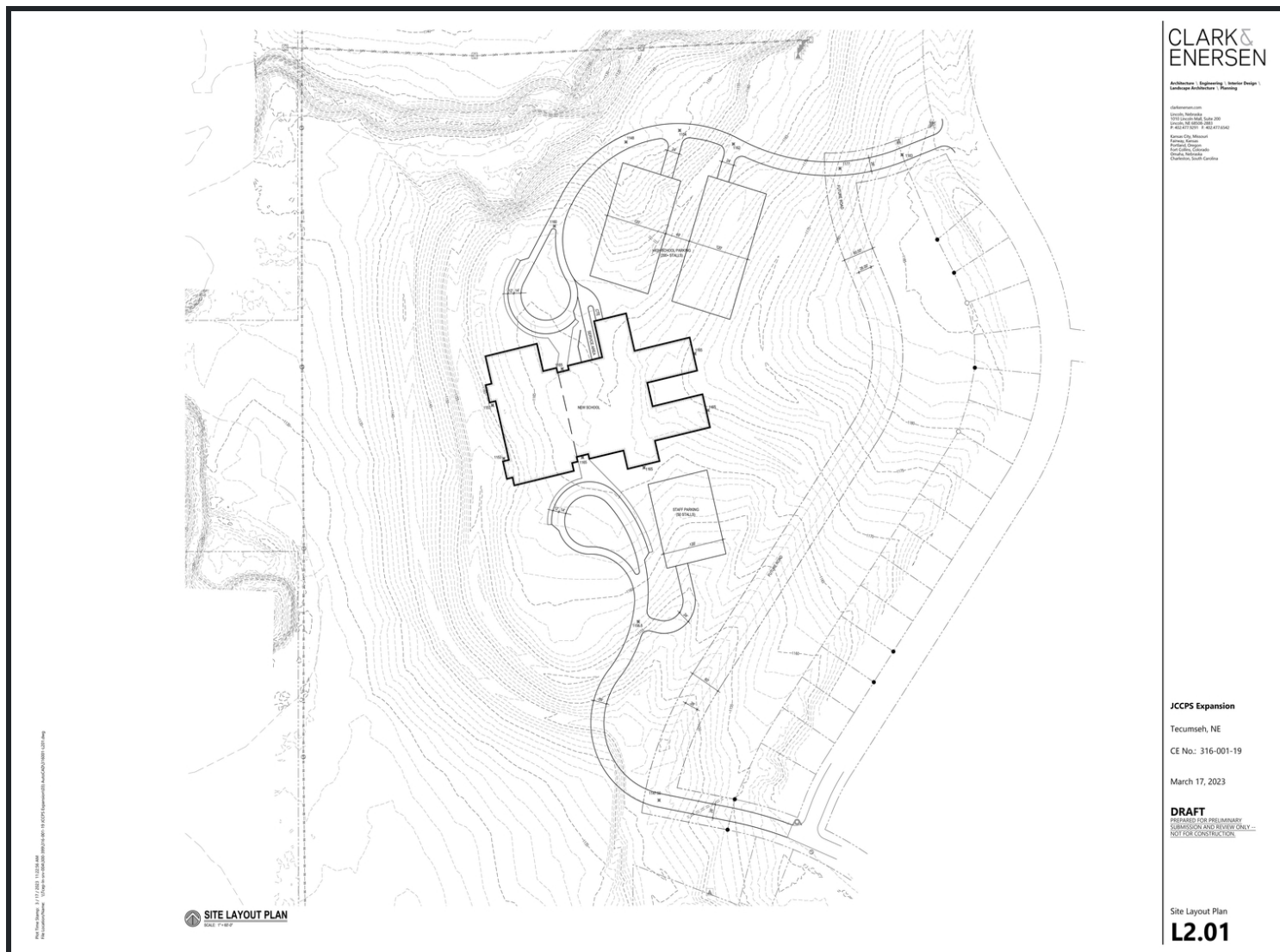

The updated building plans feature a handful of major changes:

- Total Square Footage = 123,940
- Last Year's (2022) Proposed Total Square Footage = 124,660

Compared to last year's (2022) proposed bond, this year's bond is 720 square feet less, while also adding the following spaces not included in the 2022 proposed bond:

- Added full CTE Shop (north side of HS)
- Added wrestling practice room (south side of gym)
- Added superintendent/central office

By adding these spaces to the 2023 proposed bond, the facility presented includes ALL programming needs for JCC. The current Cook Site, Tecumseh Site Elementary and High School would no longer be needed. Last year's 2022 proposed bond would still have required space in the current high school to remain open.

2023 Proposed Bond - Lower Level

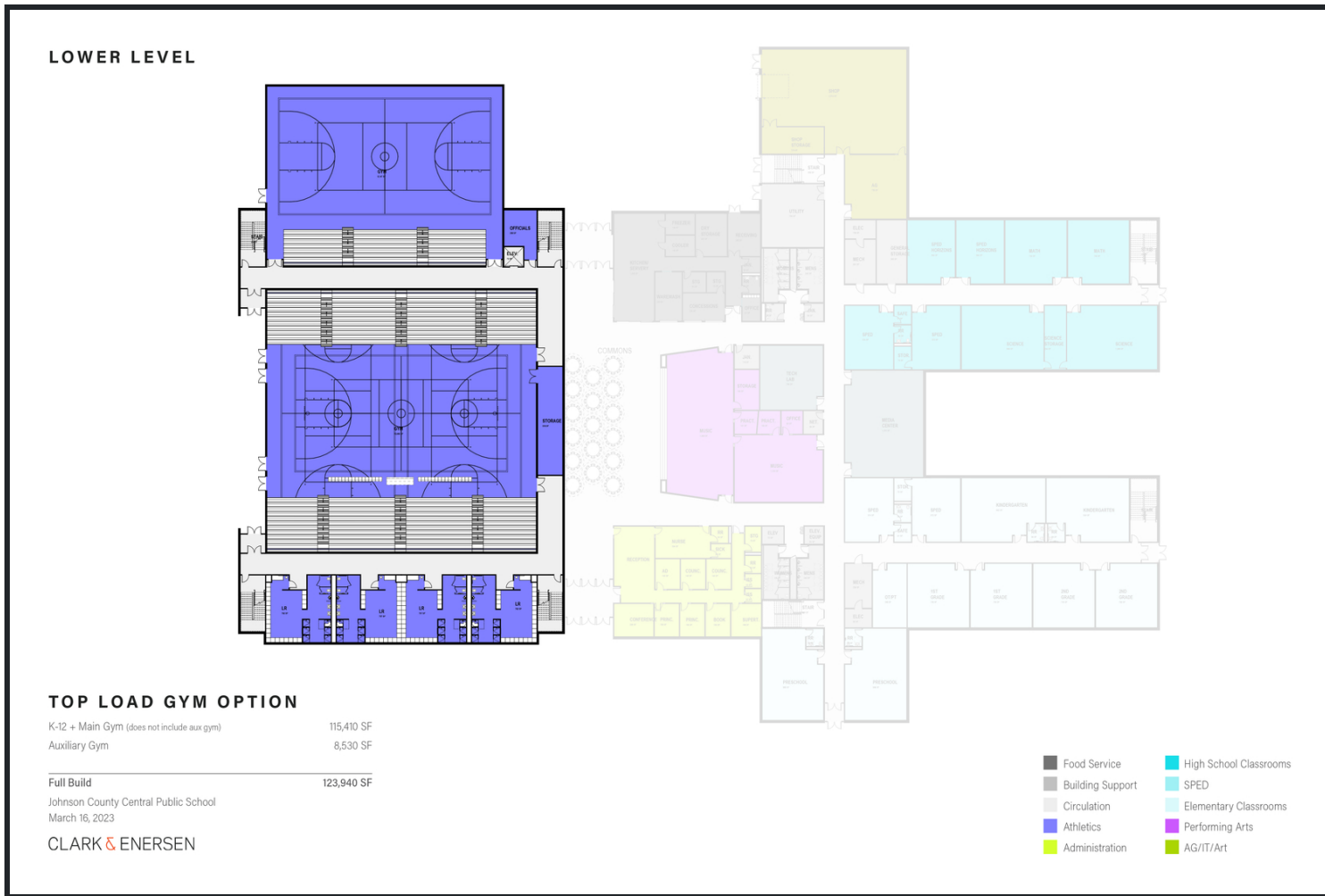

Lower Level Details: The 2023 Proposed Bond moves the gym & locker rooms to the west side. The gym floor level and locker rooms would be the lowest level, with ground level exits on the west side.

2023 Proposed Bond - First Floor

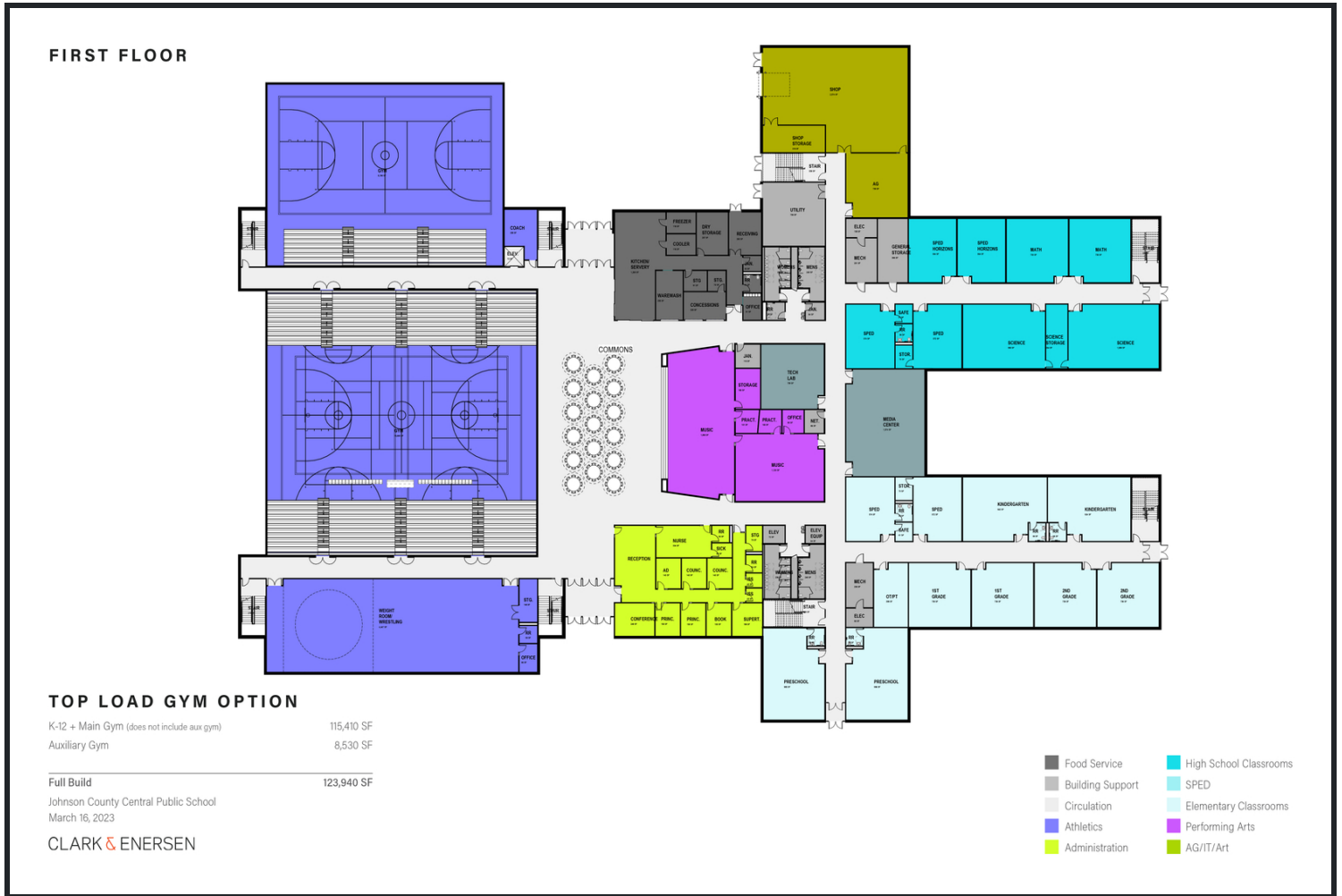

First Floor: With the gym space located to the west, the main ground level entries would not provide a true top load option to the gym. The wrestling space would be located to the south of the gym with the weight room (located above the locker rooms).

The first floor also features the added CTE shop area as well as central office (superintendent) staff.

2023 Proposed Bond - Second Floor

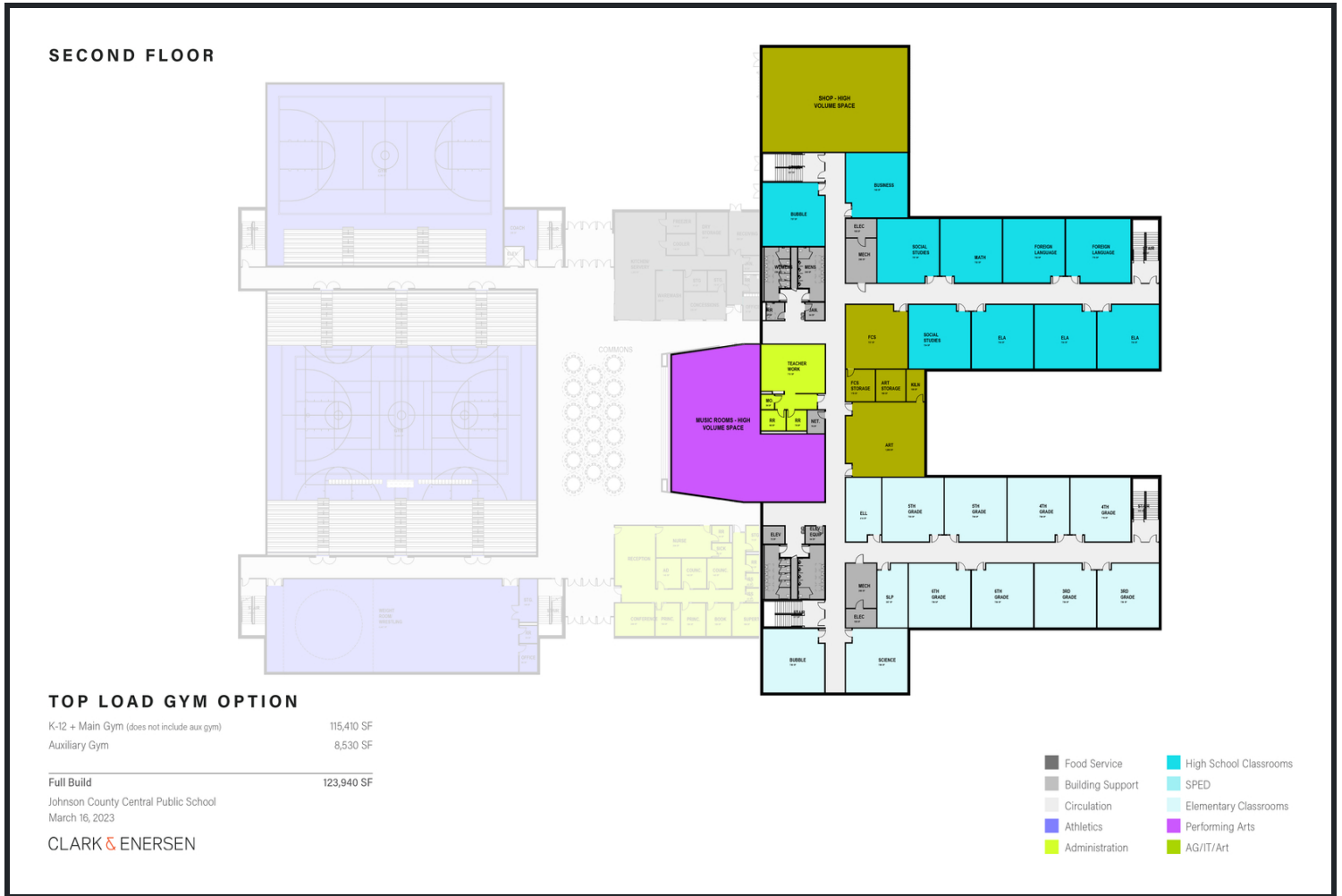

Second Floor: The second floor no longer extends as far over the middle area (the main shared spaces section of the building). By re-arranging some spaces & rooms, some hallways were eliminated to help save on square footage. The Art Room, Tech Lab, & Media Center have been moved closer to the classrooms instead above the administration offices & kitchen areas.

2023 Proposed Bond - Concept Massing

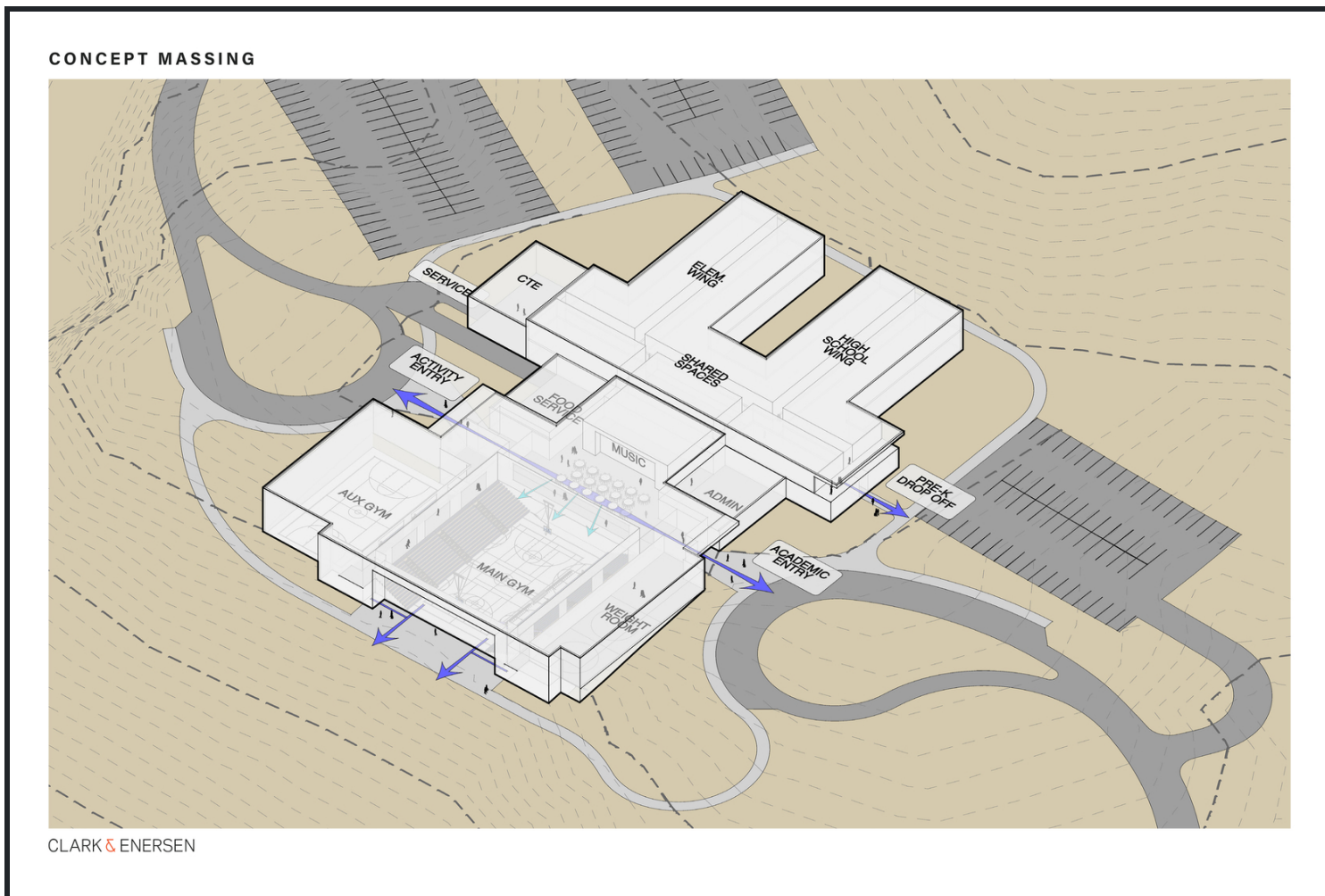

Concept Massing: This concept massing shows how the building would be located on the hill with the main entrances (Academic Entry & Activity Entry) and parking labeled. The main entrances feed into the First Floor of the building, with access to the First Floor rooms as well as the top load of the gym.

Thank you for viewing! If you would like a comparison to what the 2022 Proposed Bond plans looked like, please keep reading below:

Last Year's 2022 Proposed Bond: The previous building plans had the two main entrances (the Academic Entry and the Activities Entry) on two different floors. The plan also did not include the CTE shop, superintendent office, & wrestling room.

The site plan was also flipped with the classrooms located on the west and the gym on the east.

Last Year's 2022 Proposed Bond - First Floor

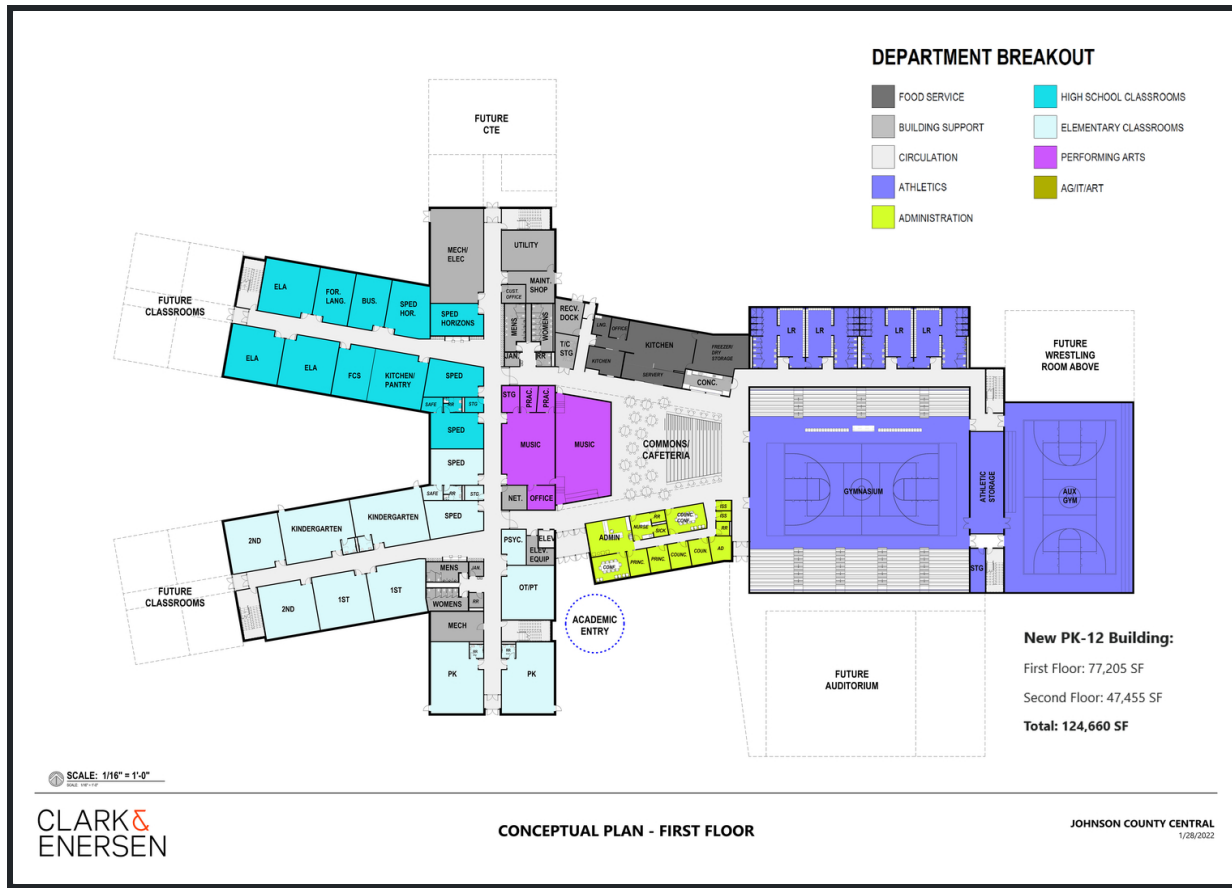

Last Year's 2022 Proposed Bond - Second Floor

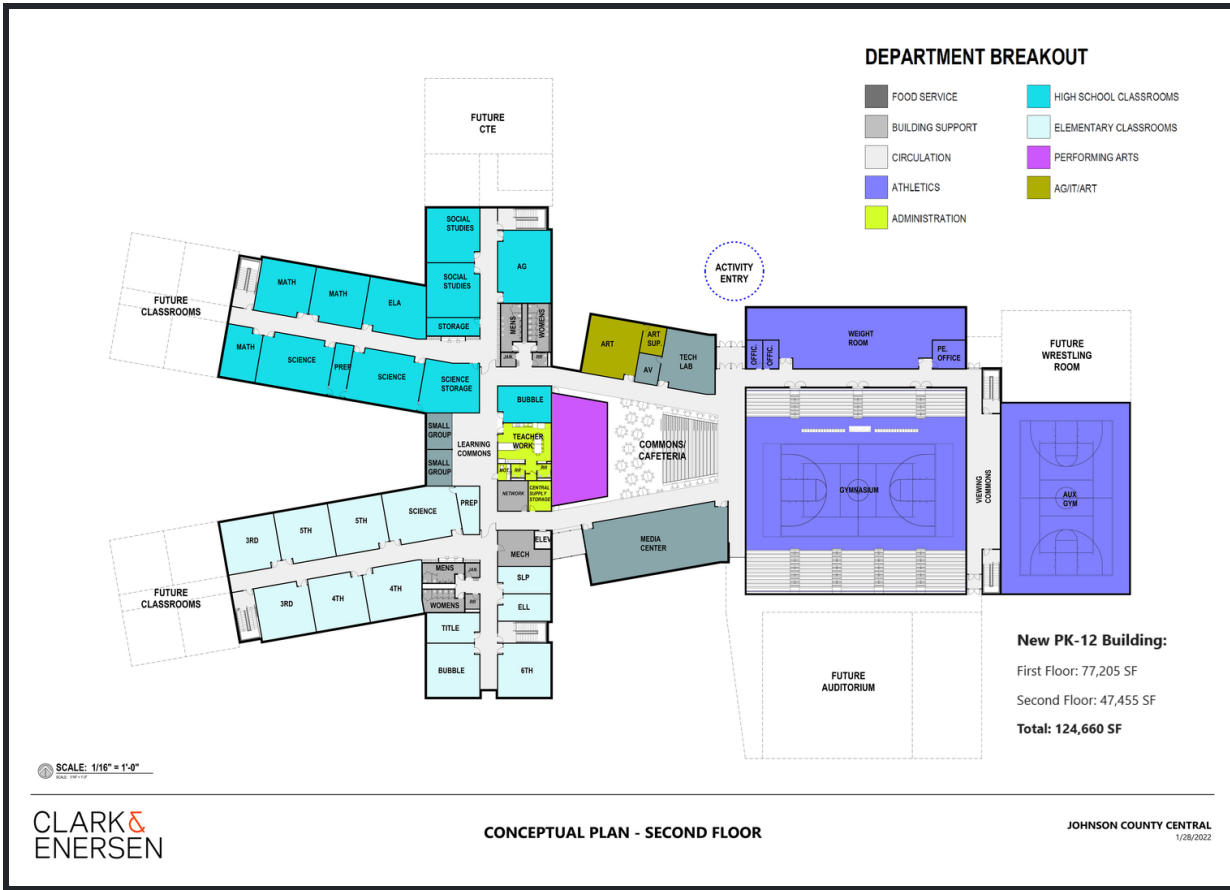

FOLLOW US



EMPLOYMENT

JOIN THE THUNDERBIRD FAMILY!
[CLICK HERE VIEW JOB OPENINGS](#)

CONTACT US

Central Office, Grades PK-3 and 9-12
358 N 6th St
Tecumseh, NE 68450
Central Office Ph: 402-335-3330
Elementary Office Ph: 402-335-3320
High School Office Ph: 402-335-3328
Fax: 402-335-3346

Grades 4-8
407 N 1st St
Cook, NE 68329
Middle School Office Ph: 402-864-4181
Fax: 402-864-2074

SOCS © 2023 Johnson County Central | [Accessibility](#) | [Privacy Pledge](#)

[This institution is an equal opportunity provider.](#)