



## Agenda of Regular Meeting

### The Board of Trustees McAllen Independent School District

---

A Regular Meeting of the Board of Trustees of the McAllen Independent School District will be held Tuesday, April 14, 2026, beginning at 5:30 PM Dr. Ricardo Chapa Board Room/Administration Building of the McAllen Independent School District, 2000 North 23rd Street, McAllen, TX 78501.

Items listed on this agenda may be taken in an order other than as shown on this agenda. Unless removed from the consent agenda, items identified within the consent agenda will be acted on at one time.

At this meeting there may be discussion and action by the Board on the item(s) and subject(s) listed as follows:

1. **CALL MEETING TO ORDER**
2. **MOMENT OF SILENCE**
3. **PLEDGE OF ALLEGIANCE**
4. **PUBLIC COMMENT(S)**
5. **PROCLAMATION(S)**
  - A) Discussion and Possible Action to Adopt the Proclamation Regarding Autism Awareness Month (April 2026) 5  
Item Submitted: Dr. Rosalba De Hoyos, Associate Superintendent for Instructional Services and Jeanette Nino, Associate Superintendent for Instructional Leadership  
**Presenter:** Dr. René Gutiérrez, Superintendent
  - B) Discussion and Possible Action to Adopt the Proclamation Regarding Month of the Military Child (April 2026) 7  
Item Submitted: Dr. Rosalba De Hoyos, Associate Superintendent for Instructional Services and Jeanette Nino, Associate Superintendent for Instructional Leadership  
**Presenter:** Dr. René Gutiérrez, Superintendent
6. **CONSENT AGENDA ITEMS**
  - A) Discussion and Possible Action on Request for Proposal No. 2025-1016 Special Education Equipment, Supplies, and Related Products and Services (Round 10) 9  
Item Submitted: Dr. Rosalba De Hoyos, Associate Superintendent for

Instructional Services and Jeanette Nino, Associate Superintendent for Instructional Leadership

**Presenter:** Dr. René Gutiérrez, Superintendent

- B) Discussion and Possible Action on Request for Proposal No. 2024-1018 Library Books, Audiovisual Supplies & Equipment, Software and Related Products and Services (Round 12) 11

Item Submitted: Dr. Rosalba De Hoyos, Associate Superintendent for Instructional Services and Jeanette Nino, Associate Superintendent for Instructional Leadership

**Presenter:** Dr. René Gutiérrez, Superintendent

- C) Discussion and Possible Action on Program Agreement No. 2026-193 with The University of Texas Rio Grande Valley (UTRGV) for The Educational Diagnostician Certification Program through Affiliation Agreement No. 2023-150 13

Item Submitted: Dr. Rosalba De Hoyos, Associate Superintendent for Instructional Services and Jeanette Nino, Associate Superintendent for Instructional Leadership

**Presenter:** Dr. René Gutiérrez, Superintendent

- D) Discussion and Possible Action on Request for Proposal No. 2025-1027 Building and Maintenance, Materials, Supplies, Equipment, and Related Services (Round 4) 19

Item Submitted: Lorena Garcia, Deputy Superintendent for Business and Operations

**Presenter:** Dr. René Gutiérrez, Superintendent

- E) Discussion and Possible Action on Request for Proposal No. 2026-1029 Fresh Produce for Child Nutrition Program 21

Item Submitted: Lorena Garcia, Deputy Superintendent for Business and Operations

**Presenter:** Dr. René Gutiérrez, Superintendent

**7. INSTRUCTIONAL SERVICES/ INSTRUCTIONAL LEADERSHIP, HUMAN RESOURCES, BUSINESS AND OPERATIONS, AND BOARD OF TRUSTEES ITEMS**

- A) **Instructional Services/ Instructional Leadership Item(s)** (Dr. Rosalba De Hoyos and/or Jeanette Nino)

1. Report Regarding Pre-Kinder through 2nd Grades Literacy Efforts and Student Outcomes 24

Item Submitted: Jeanette Nino, Associate Superintendent for Instructional Leadership

**Presenter:** Dr. René Gutiérrez, Superintendent

2. Report Regarding 2026-2027 McAllen I.S.D. Advanced Scholars Academy at Wilson Elementary 42

Item Submitted: Jeanette Nino, Associate Superintendent for Instructional Leadership

**Presenter:** Dr. René Gutiérrez, Superintendent

3. Discussion and Possible Action of Donation on Behalf of Capable Kids and the Wonderful Company for Rayburn Elementary 58

Item Submitted: Jeanette Nino, Associate Superintendent for Instructional Leadership

**Presenter:** Presenter: Dr. René Gutiérrez, Superintendent

**B) Human Resources Item(s)** (Dr. Albert Canales)

1. Report Regarding the 2026 Bond 77  
Item Submitted: Dr. Albert Canales, Chief Human Resources Officer

**Presenter:** Dr. René Gutiérrez, Superintendent

2. Discussion and Possible Action on Contract Agreement No. 2026-265 for Election Services and Voting Equipment between the County of Hidalgo and the McAllen Independent School District for the Bond Election on May 2, 2026, with Early Voting to be Conducted from April 20, 2026 through April 28, 2026 83  
Item Submitted: Dr. Albert Canales, Chief Human Resources Officer

**Presenter:** Dr. René Gutiérrez, Superintendent

**C) Business and Operations Item(s)** (Lorena Garcia)

1. Report Regarding Nurturing Student Health: McAllen ISD 3-Year Plan 95  
Item Submitted: Lorena Garcia, Deputy Superintendent for Business and Operations

**Presenter:** Dr. René Gutiérrez, Superintendent

2. Report Regarding No. 2022-187 between Texas Association of School Boards Risk Management Fund and McAllen Independent School District 111  
Item Submitted: Dr. Albert Canales, Chief Human Resources Officer

**Presenter:** Dr. René Gutiérrez, Superintendent

3. Discussion and Possible Action on McAllen Independent School District March Budget Amendment for Fiscal Year Beginning July 1, 2025 and Ending June 30, 2026 118  
Item Submitted: Lorena Garcia, Deputy Superintendent for Business and Operations

**Presenter:** Dr. René Gutiérrez, Superintendent

**D) Board of Trustees Item(s)**

1. Discussion and Possible Action on Approval of Board of Education Meeting Minutes 124

2. Discussion and Possible Action of Travel by the Board of Trustees 140

**8. RECESS TO CLOSED SESSION: Board of Trustees may go into Closed Session pursuant to Section(s) 551.071, 551.072, 551.074, 551.076, and 551.089 Texas Government Code, to discuss the following:**

A) Human Resources Recommendation(s) for School Year 2025-2026

B) Discussion of Human Resources Employee Resignation(s) and Retirees for School Year 2025-2026

- C) Discussion Regarding School Safety and Security
  - D) Pending and/or Potential Litigation
  - E) Possible Real Estate Acquisition
9. **RECONVENE IN OPEN SESSION**
10. **ACTION ON ITEM(S) IN CLOSED SESSION**
- A) Discussion and Possible Action of Human Resources 144  
 Recommendation(s) for School Year 2025-2026  
 Item Submitted: Dr. Albert Canales, Chief Human Resources Officer  
**Presenter:** Dr. René Gutiérrez, Superintendent
  - B) Discussion of Human Resources Employee Resignation(s) and Retirees 145  
 for School Year 2025-2026  
 Item Submitted: Dr. Albert Canales, Chief Human Resources Officer  
**Presenter:** Dr. René Gutiérrez, Superintendent
  - C) Discussion Regarding School Safety and Security
  - D) Pending and/or Potential Litigation
  - E) Possible Real Estate Acquisition
11. **SCHEDULED MEETINGS**
- A. Regular Board Meeting April 28, 2026 - 5:30 pm - Administration Building/Dr. Ricardo Chapa Board Room
  - B. Budget Workshop #4 May 5, 2026 - 5:30 pm - Administration Building/Dr. Ricardo Chapa Board Room
  - C. Special Board Meeting May 12, 2026 - 5:30 pm - Administration Building/Dr. Ricardo Chapa Board Room
  - D. Regular Board Meeting May 12, 2026 - 6:00 pm - Administration Building/Dr. Ricardo Chapa Board Room
12. **ADJOURNMENT**

---

*If, during the course of the meeting, discussion of any item on the agenda should be held in a closed meeting, the Board will conduct a closed meeting in accordance with the Texas Open Meetings Act, Government Code, Chapter 551, Subchapters D and E. Before any closed meeting is convened, the presiding officer will publicly identify the section or sections of the Act authorizing the closed meeting. All final votes, actions, or decisions will be taken in open meeting.*

*Pursuant to Texas Government Code 551.127, a member or employee of a governmental body is authorized to participate remotely in a meeting of the governmental body through a videoconference call, as long as a quorum of the governmental body is physically present at the location of the Board Meeting. Any video conference conducted pursuant to this section will comply with the technical requirements of this section.*

*Pursuant to Texas Government Code 551.129, the Board of Trustees may use a telephone conference call, video conference call, or communications over the internet to conduct a public consultation with its attorney in an open meeting of the governmental body, or, a private consultation with its attorney in closed meeting of the governmental body.*

*The notice for this meeting was posted in compliance with the Texas Open Meeting Action on April 8, 2026 by 5:00 p.m. Norma Ramirez, on behalf of Board of Trustees.*

**BOARD AGENDA REPORT  
MCALLEN INDEPENDENT SCHOOL DISTRICT**

**MEETING DATE:** April 14, 2026

**SUBJECT:** Discussion and Possible Action to Adopt the Proclamation Regarding Autism Awareness Month (April 2026)

**REFERENCE:** Goal 1: Students Achievement/Student Focus

**BACKGROUND INFORMATION/REASON FOR BOARD CONSIDERATION:**

To proclaim April as Autism Awareness Month and to raise awareness about autism throughout our schools and community. To recognize the successes of our Autistic students and the teaching of our Special Education staff.

**ADMINISTRATIVE CONSIDERATIONS/FACTS AND ANALYSIS:**

N/A

**LEGAL REVIEW:**

None Required.

**BUDGETARY CONSIDERATIONS:**

None Required.

**RECOMMENDED BOARD ACTION:**

That the Board of Trustees adopt the Proclamation Regarding Autism Awareness Month (April 2026).

Attachment:

**SUBMITTED BY:**   
Maribelle Elizondo (Apr 2, 2026 14:50:43 CDT)

**SUPERVISOR:**   
Rosalba De Hoyos (Apr 2, 2026 15:18:57 CDT)

**SUPERVISOR:**   
Jeanette Nino (Apr 2, 2026 16:21:20 CDT)

For further information contact:

Name: Maribelle Elizondo

Office: 956-632-3285

eMail:maribelle.elizondo@mcallenisd.net

**Approved for presentation to the Board of Education:**

5   
RENE GUTIERREZ (Apr 2, 2026 16:34:40 CDT)

**Superintendent of Schools**



# *Proclamation*

*State of Texas  
County of Hidalgo  
McAllen Independent School District*

*Whereas*, In 2007 the United Nations General Assembly adopted resolution 62/139 World Autism Awareness Day by unanimous consent, encouraging United Nation Members States to take measures to raise awareness about autism throughout society; and

*Whereas*, the resolution designates World Autism Awareness Day as a United Nations Day to be observed every year starting in 2008 to raise global awareness of autism; and

*Whereas*, the aims for World Autism Awareness Day is to inform the general public about the global health crisis of autism, stress the importance of early diagnosis and early intervention, and to celebrate the unique talents and qualities of individuals with autism;

*Now Therefore*, I, Sofia M. Peña, Member, Board of Trustees of the McAllen Independent School District, do hereby proclaim that the month of April 2026 be observed as:

*“Autism Awareness Month”*

*IN WITNESS WHEREOF*, I have hereunto set my hand and caused the seal of the McAllen Independent School District to be affixed on this 14th day of April 2026.

---

Sofía M. Peña, Member, Board of Trustees  
McAllen Independent School District

*Attest:*

---

Dr. Elizabeth Kittleman, Secretary, Board of Trustees  
McAllen Independent School District

**BOARD AGENDA REPORT  
MCALLEN INDEPENDENT SCHOOL DISTRICT**

**MEETING DATE:** April 14, 2026

**SUBJECT:** Discussion and Possible Action to Adopt the Proclamation Regarding Month of the Military Child (April 2026)

**REFERENCE:** Goal 1: Student Achievement/Student Focus

**BACKGROUND INFORMATION/REASON FOR BOARD CONSIDERATION:**

April is the month of the Military Child. During the Month of the Military Child, we appreciate families and their children for the sacrifices they make at home while their loved ones are out serving their country. Purple Up Day "For Military Kids" initiative designates a given day in April to wear the color purple to recognize the children of military families. Wearing purple is a visible way to show support and thank military youth for their strength and sacrifices. The color purple represents a combination of all the branches of the military.

April 17, 2026 was designated and observed as Purple Up Day in McAllen ISD.

**ADMINISTRATIVE CONSIDERATIONS/FACTS AND ANALYSIS:** N/A

**LEGAL REVIEW:** None Required.

**BUDGETARY CONSIDERATIONS:** None Required.

**RECOMMENDED BOARD ACTION:** That the Board of Trustees adopt the Proclamation Regarding Month of the Military Child (April 2026).

Attachment:

**SUBMITTED BY:** Jose Soto

**SUPERVISOR:**  Rosalba De Hoyos (Apr 2, 2026 15:19:16 CDT)

**SUPERVISOR:**  Jearrette Nino (Apr 2, 2026 16:20:59 CDT)

For further information contact:  
Name: Jose Soto  
Office: 956-657-6096  
eMail: jose.soto@mcallsisd.net

**Approved for presentation to the Board of Education:**  
 RENE GUTIERREZ (Apr 2, 2026 16:34:11 CDT)  
**Superintendent of Schools**



# *Proclamation*

*State of Texas  
County of Hidalgo  
McAllen Independent School District*

*Whereas*, as Americans, we owe a tremendous debt to those who serve to protect and promote our freedom. It is important to remember the men and women in uniform are not alone in making sacrifices; their families, specially their children, are together in the sacrifice; and

*Whereas*, Each April we make a special effort to applaud military families and pay tribute to the resilient nature of military children; and

*Whereas*, Purple Up! For Military connected students on April 17<sup>th</sup> designated to observe the strength and sacrifices of military children across the country;

*Now Therefore*, I, Aaron D. Rivera, President, Board of Trustees of the McAllen Independent School District, do hereby proclaim that the month of April 2026 be observed as:

*“Month of the Military Child”*

*IN WITNESS WHEREOF*, I have hereunto set my hand and caused the seal of the McAllen Independent School District to be affixed on this 14<sup>th</sup> day of April 2026.

\_\_\_\_\_  
Aaron D. Rivera, President, Board of Trustees  
McAllen Independent School District

*Attest:*

\_\_\_\_\_  
Dr. Elizabeth Kittleman, Secretary, Board of Trustees  
McAllen Independent School District

**BOARD AGENDA REPORT  
MCALLEN INDEPENDENT SCHOOL DISTRICT**

**MEETING DATE:** April 14, 2026

**SUBJECT:** Discussion and Possible Action on Request for Proposal No. 2025-1016 Special Education Equipment, Supplies, and Related Products and Services (Round 10)

**REFERENCE:** Goal 1: Student Achievement/Student Focus; Strategy 3: Engaging Learning Environments

**BACKGROUND INFORMATION/REASON FOR BOARD CONSIDERATION:**

The McAllen Independent School District solicited proposals for special education equipment, supplies, and related products and services. This Request for Proposal ("RFP") is an extended response period, multiple award contract, solicited in accordance with the Financial Accountability System Resource Guide ("FASRG"), section 5.16, titled "Multiple/Catalog/Discount-from-List Contract Awards." This allows vendors to submit responses throughout the year through the contract term. Vendors are awarded on an incremental basis upon the Board of Trustees' approval. Ninety-eight (98) vendors were previously awarded through this RFP.

**ADMINISTRATIVE CONSIDERATIONS/FACTS AND ANALYSIS:**

Seven hundred ninety (790) vendors were invited to submit proposals, and twenty-four (24) vendors responded, including thirteen (13) no-bid responses, one (1) previously awarded with changes, and two (2) non-responsive. The evaluation committee, comprised of Maribelle Elizondo, Executive Director for Special Education; Liza Lara, Director of Regional Day School Program for the Deaf; Laura Williams, Director of Purchasing Services; Elizabeth Cabrera, Coordinator for Purchasing Services; and Corina Tijerina, Buyer, evaluated the proposals. Administration is recommending that the eight (8) companies listed on the attached list be approved as qualified vendors, for a total of one hundred six (106) vendors.

**LEGAL REVIEW:**

None required.

**BUDGETARY CONSIDERATIONS:**

Funds for these services have been budgeted through local, state, federal, and grant funds.

**RECOMMENDED BOARD ACTION:**

Administration recommends that the Board of Trustees approve Request for Proposal No. 2025-1016 Special Education Equipment, Supplies, and Related Products and Services (Round 10), and approve the companies on the attached list as qualified vendors, for a coterminous term through June 30, 2028.

Attachment:

**SUBMITTED BY:**   
Maribelle Elizondo (Apr 2, 2026 16:01:56 CDT)

**SUPERVISOR:**   
Rosalba De Hoyos (Apr 2, 2026 16:25:57 CDT)

**SUPERVISOR:**   
Jearrette Nino (Apr 2, 2026 16:26:45 CDT)

For further information contact:  
Name: Mrs. Maribelle Elizondo, Executive Director for  
Special Education  
Office: (956) 632-3285  
eMail: maribelle.elizondo@mcallenisd.net

**Approved for presentation to the Board of Education:**  
  
9 RENE GUTIERREZ (Apr 2, 2026 16:35:43 CDT)  
**Superintendent of Schools**

**RECOMMENDED VENDORS**  
**Request for Proposal No. 2025-1016**  
**Special Education Equipment, Supplies, and Related Products and Services (Round 10)**

No.	Vendor Name	City	State	Recommendation
1	Dawn Educational Services (Elizabeth Dawn Zamora)	edcouch	TX	Qualified
2	Desert Star Therapy LLC	El Paso	TX	Qualified
3	IDR Healthcare, LLC	Alpharetta	GA	Qualified
4	MaxScholar LLC (Self)	Aventura	FL	Qualified
5	Metadil USA Corporation	Hallandale Beach	FL	Qualified
6	MindBridge Solutions Assessment & Consulting, LLC	Sugar Land	TX	Qualified
7	Thriving Students Collective, Inc	Lafayette	CA	Qualified
8	Wilson Language Training Corporation	Oxford	MA	Qualified

**BOARD AGENDA REPORT  
MCALLEN INDEPENDENT SCHOOL DISTRICT**

**MEETING DATE:** April 14, 2026

**SUBJECT:** Discussion and Possible Action on Request for Proposal No. 2024-1018 Library Books, Audiovisual Supplies & Equipment, Software and Related Products and Services (Round 12)

**REFERENCE:** Goal 1 - Student Achievement/Student Focus; Strategy 3 - Engaging Learning Environments

**BACKGROUND INFORMATION/REASON FOR BOARD CONSIDERATION:**

The McAllen Independent School District solicited proposals for library books, audiovisual supplies & equipment, software and related products and services. This Request for Proposal ("RFP") is an extended response period, multiple award contract, solicited in accordance with the Financial Accountability System Resource Guide ("FASRG"), section 5.16, titled "Multiple/Catalog/Discount-from-List Contract Awards". This allows vendors to submit responses throughout the year through the contract term. Vendors are awarded on an incremental basis, upon the Board of Trustees ("Board") approval. Ninety-six (96) vendors were previously awarded through this RFP.

**ADMINISTRATIVE CONSIDERATIONS/FACTS AND ANALYSIS:**

Five hundred sixty-four (564) vendors were invited to submit proposals, and twenty one (21) vendors responded, including fourteen (14) no bid responses, one (1) duplicate, and one (1) non-responsive. The evaluation committee, comprised of Jenny Ann Vega, Director of Digital Learning and Library Services; Laura Williams, Director of Purchasing Services; Elizabeth Cabrera, Coordinator for Purchasing Services; and Corina Tijerina, Buyer, evaluated the proposals. Administration is recommending that the five (5) vendors listed on the attached list be awarded for a total of one hundred one (101) vendors on this RFP.

**LEGAL REVIEW:**

None required.

**BUDGETARY CONSIDERATIONS:**

Funds for these purchases are budgeted through local, state, federal, and grant funds.

**RECOMMENDED BOARD ACTION:**

Administration recommends that the Board of Trustees approve Request for Proposal No. 2024-1018 Library Books, Audiovisual Supplies & Equipment, Software and Related Products and Services (Round 12), and approve the companies on the attached list as qualified vendors, for a coterminous term through June 30, 2027.

Attachment:

**SUBMITTED BY:** Jenny Ann Vega

**SUPERVISOR:**   
Rosalba De Hoyos (Apr 2, 2026 16:27:28 CDT)

**SUPERVISOR:**   
Jearrette Nino (Apr 2, 2026 16:28:33 CDT)

For further information contact:  
Name: Ms. Jenny Ann Vega, Director of Digital  
Learning and Library Services  
Office: 956-972-5600  
eMail: jennyann.vega@mcallenisd.net

**Approved for presentation to the Board of Education:**  
  
11 RENE GUTIERREZ (Apr 2, 2026 16:36:37 CDT)  
**Superintendent of Schools**

**RECOMMENDED VENDORS**  
**Request for Proposal No. 2024-1018**  
**Library Books, Audiovisual Supplies & Equipment, Software and Related Products and Services (Round 12)**

<b>No.</b>	<b>Vendor Name</b>	<b>City</b>	<b>State</b>	<b>Recommendation</b>
1	Cyproteck Inc	Hartford	CT	Qualified
2	Adorama Inc.	NEW YORK	NY	Qualified
4	Discount School Supply (Earlychildhood LLC)	Monterey	CA	Qualified
5	REALLY GOOD STUFF, LLC.	Shelton	CT	Qualified
6	McGraw Hill LLC	Columbus	OH	Qualified

**BOARD AGENDA REPORT  
MCALLEN INDEPENDENT SCHOOL DISTRICT**

**MEETING DATE:** April 14, 2026

**SUBJECT:** Discussion and Possible Action on Program Agreement No. 2026-193 with The University of Texas Rio Grande Valley (UTRGV) for The Educational Diagnostician Certification Program through Affiliation Agreement No. 2023-150.

**REFERENCE:** Goal 1 - Student Achievement/Student Focus; Strategy 3 - Engaging Learning Environment

**BACKGROUND INFORMATION/REASON FOR BOARD CONSIDERATION:**

This program agreement with the University of Texas Rio Grande Valley ("UTRGV") designates the responsibilities between University and McAllen Independent School District ("District") in the Educational Diagnostician Certification Program for students enrolled at the University.

**ADMINISTRATIVE CONSIDERATIONS/FACTS AND ANALYSIS:**

The purpose of the program agreement is for UTRGV to partner with the District to train Educational Diagnostician students to complete their practicum in our District. District will commit to provide students with a continuing learning experience.

**LEGAL REVIEW:**

The program agreement has been approved by legal counsel.

**BUDGETARY CONSIDERATIONS:**

None

**RECOMMENDED BOARD ACTION:**

Administration recommends that the Board of Trustees approve Program Agreement No. 2026-193 with University of Texas Rio Grande Valley (UTRGV) for the Educational Diagnostician Certification Program under Affiliation Agreement No. 2023-150. The agreement will automatically renew annually unless either party provides 180 days' prior written notice of intent to terminate.

Attachment:

**SUBMITTED BY:**   
Maribelle Elizondo (Apr 2, 2026 16:01:26 CDT)

**SUPERVISOR:**   
Rosalba De Hoyos (Apr 2, 2026 16:26:30 CDT)

**SUPERVISOR:**   
Jeanette Nino (Apr 2, 2026 16:27:53 CDT)

For further information contact:  
Name: Mrs. Maribelle Elizondo, Executive Director for  
Special Education  
Office: (956) 632-3285  
eMail: maribelle.elizondo@mcallenisd.net

**Approved for presentation to the Board of Education:**  
  
13 RENE GUTIERREZ (Apr 2, 2026 16:36:12 CDT)  
**Superintendent of Schools**



Department of Purchasing Services

Contract No.: 2026-193

**Contract Coversheet and Signature Form  
for  
Forms/Contracts Requiring Superintendent Approval**

This form standardizes the contract process and is to be used as the cover sheet to ensure complete review by appropriate department(s)/campus(es).

Special Education  
Department/Campus Name

<u>Sponsor</u>	<u>Signature</u>	<u>Date</u>
<u>Campus Principal</u>	<u>Signature</u>	<u>Date</u>
<u>Maribelle Elizondo</u>	<u><i>Maribelle Elizondo</i></u> <small>Maribelle Elizondo (Mar 13, 2026 10:50:50 CDT)</small>	<u>03/13/2026</u>
<u>Department Director</u>	<u>Signature</u>	<u>Date</u>

## THE EDUCATIONAL DIAGNOSTICIAN CERTIFICATION PROGRAM

### PROGRAM AGREEMENT

(Education Experience)

#### Recitals

- A. The University of Texas Rio Grande Valley (“University”) and McAllen Independent School District (“Facility”) have previously executed an Affiliation Agreement effective on March 1, 2023 and
- B. University and Facility desire to implement the provisions of such Affiliation Agreement by providing students enrolled in University’s Educational Diagnostician certification program with educational experience utilizing the personnel, equipment, and facilities of Facility.

#### Agreement

NOW THEREFORE, subject to the terms, conditions, and provisions of such Affiliation Agreement, the parties agree as follows:

- 1. **PROGRAM.** Facility Liaison and University Representative will design an educational experience in Educational Diagnostician certification (“Program”) for University students utilizing the personnel, equipment, and facilities of Facility.
  - a. The duration of the Program and the educational experience provided will be consistent with the curriculum requirements of University and with the standards of the accrediting entity for the school or division of University in which the students are enrolled. The Texas Education Agency requires a minimum of 160 hours in an educational school setting.
  - b. The Program will be reviewed periodically by the Facility Liaison and University Representative and, when appropriate, will be revised to meet the University curriculum requirements and the standards of the accrediting entity.
  - c. The educational experience for students in the Program will be an integral part of the services provided by Facility and students will be under the direct supervision of University personnel or Facility personnel who are licensed or otherwise qualified to perform such services. Students shall not be used to provide services in lieu of professional or non-professional staff.
- 2. **UNIVERSITY OBLIGATIONS.**
  - a. Assure that all students selected for participation in Program have satisfactorily completed all portions of the University curriculum that are a prerequisite for participation in the Program.
  - b. Develop criteria for the evaluation of the performance of University

students participating in the Program and provide those criteria, with appropriate reporting forms, to the Facility personnel and University personnel who are responsible for supervising those students.

- c. Assign grades to students participating in the Program on the basis of the performance evaluations submitted in the reporting forms.
- d. Inform all University students and personnel participating in the Program that they are required to comply with the rules and regulations of Facility while on premises of Facility and to comply with the requirements of federal and state laws and regulations regarding the confidentiality of information in records maintained by Facility.
- e. Provide information requested by Facility related to students participating in the Program unless prohibited by federal or state law.
- f. Remove a student from the Program when the Facility determines that the student has violated the rules and regulations of the Facility; has disclosed information that is confidential by law; or has engaged in conduct that disrupts the activities carried on by the Facility or threatens the safety of Facility personnel or patients.

### **3. FACILITY OBLIGATIONS.**

- a. Assign appropriate space on Facility premises for offices, lectures, and other non- experience related activities of the Program.
- b. Provide the equipment, supplies, qualified personnel, and supervised access to students required for the experience related activities of the Program.
- c. Obtain and maintain all licenses required for Facility and assure that all Facility personnel are appropriately licensed.
- d. Assume sole responsibility for the quality of assessments and decision-making based on the assessments of students.
- e. Provide orientation sessions to inform University students and personnel concerning the rules and regulations of Facility.
- f. Permit representatives of the accrediting entity for the school or division of University in which students participating in the Program are enrolled to have reasonable access to premises of Facility for purposes related to the accreditation process.

**4. RESPONSIBILITIES OF UNIVERSITY AND FACILITY.**

- a. The number of University students receiving practicum training at Facility will be determined by the University and Facility, with due consideration given to Facility students available for participation in the Program.
- b. Proper communication channels will be maintained when planning for practicum student experiences.
- c. Facility will assign University Students to career-related tasks and activities as required in the University Educational Diagnostician program. University will clarify such requirements so that Facility may assign appropriate tasks and activities. Such tasks and activities as assigned by Facility, in accordance with law, regulation, and accepted standards of practice in educational diagnostics will include the following: (a) orientation to school settings; (b) learning the role of the Educational Diagnostician; (c) evaluation of EC-12 students' cognitive abilities; academic achievement; social, emotional, and behavioral challenges; and other related areas of student assessment; (d) consultation with parents and Facility authorized personnel; and (e) direct participation in Admission, Review, and Dismissal (ARD) meetings under the supervision of appropriate Facility personnel. The University Students will be informed that they shall, at all times, endeavor to meet the specified needs of Facility's programs as determined by Facility. In addition to other specified tasks and activities, the University student shall be permitted to gather data on eligible Facility students and, in appropriate cases, shall participate in conferences dealing with such Facility, where such conferences are not in conflict with law and are in conformity with the policies, rules, regulations and objectives of Facility. The University student shall share information with appropriate Facility personnel as required and shall maintain the appropriate confidentiality standards of Facility, as well as state and federal law. While performing assigned tasks and activities at Facility, the University student will be supervised by a University faculty member who is certified as an Educational Diagnostician and is qualified to provide educational diagnostician services in schools. A Facility Educational Diagnostician will also be assigned to oversee the activities of the University student at the Facility. Facility and University will obtain consents from parents prior to University students undertaking any task or activities with Facility students.

**5. GENERAL PROVISIONS.**

- a. University students and personnel will be responsible for their own transportation, meals, and health care while participating in the Program.
- b. This Program Agreement and the Affiliation Agreement constitute the entire agreement between the parties with respect to the subject matter and no prior or contemporaneous agreement, written or oral, will be effective to vary the

terms of those Agreements. No amendment to this Program Agreement shall be effective unless reduced to writing and signed by an authorized representative of each party.

- c. University and Facility will comply with all applicable federal, state, and local laws, ordinances, and regulations in the performance of this Program Agreement.
- d. The Program and all related activities shall be conducted in a manner that does not discriminate against any person on a basis prohibited by applicable law, including but not limited to: race, color, national origin, religion, sex, age, veteran status, or disability.
- e. The initial Program shall begin on September 1, 2025 and end on [August 31, 2030]. This Agreement may be terminated at any time and for any reason by either Party upon not less than thirty days prior written notice to the other Party. Should notice of termination be given under this Section, students already scheduled to train at Facility will be permitted to complete any previously scheduled clinical assignment at Facility-

THE UNIVERSITY OF TEXAS  
RIO GRANDE VALLEY:

McAllen Independent School District:

By: \_\_\_\_\_  
Luis H. Zayas, Ph.D  
Provost and Senior Vice President for  
Academic Affairs

By: \_\_\_\_\_  
Dr. Rene Gutierrez  
Superintendent  
(Name and Title)

Date: \_\_\_\_\_

Date: \_\_\_\_\_

By: \_\_\_\_\_  
Dr. Christine Shupala  
Vice Provost for Institutional Accreditation,  
Program Development, and Analysis

By: \_\_\_\_\_  
Aaron D. Rivera  
President

Date: \_\_\_\_\_

Date: \_\_\_\_\_

Approved as to form

by:   
JOHNATHAN BALL (Mar 13, 2026 12:13:49 CDT)  
Johnathan Ball, Staff Attorney

UTRGV CONTRACT ID: \_\_\_\_\_

**BOARD AGENDA REPORT  
MCALLEN INDEPENDENT SCHOOL DISTRICT**

**MEETING DATE:** April 14, 2026

**SUBJECT:** Discussion and Possible Action on Request for Proposal No. 2025-1027 Building and Maintenance, Materials, Supplies, Equipment, and Related Services (Round 4)

**REFERENCE:** Goal 3 - Facility Priorities; Strategy 7 - Financial Priorities

**BACKGROUND INFORMATION/REASON FOR BOARD CONSIDERATION:**

The McAllen Independent School District solicited proposals for building and maintenance, materials, supplies, equipment, and related services. This Request for Proposal ("RFP") is an extended response period, multiple award contract, solicited in accordance with the Financial Accountability System Resource Guide ("FASRG"), section 5.16, titled "Multiple/Catalog/Discount-from-List Contract Awards". This allows vendors to submit responses throughout the year through the contract term. Vendors are awarded on an incremental basis, upon the Board of Trustees ("Board") approval. Fifty-six (56) vendors were previously awarded through this RFP.

**ADMINISTRATIVE CONSIDERATIONS/FACTS AND ANALYSIS:**

Six hundred eighty-three (683) vendors were invited to submit proposals, and twelve (12) vendors responded, including four (4) no bid responses, three (3) previously awarded with no changes, and one (1) non-responsive. The evaluation committee, comprised of Ruben Treviño, Executive Director for Facilities, Maintenance, and Operations; Laura Williams, Director of Purchasing Services; Elizabeth Cabrera, Coordinator for Purchasing Services; and Sandra Pulido, Buyer, evaluated the proposals. Administration is recommending that the four (4) companies listed on the attached list be approved as qualified vendors, for a total of sixty (60) vendors.

**LEGAL REVIEW:**

None Required

**BUDGETARY CONSIDERATIONS:**

Funds for these purchases are budgeted through local, state, federal, and grant funds.

**RECOMMENDED BOARD ACTION:**

Administration recommends that the Board of Trustees approve Request for Proposal No. 2025-1027 Building and Maintenance, Materials, Supplies, Equipment, and Related Services (Round 4), and approve the companies on the attached list as qualified vendors, for a coterminous term through June 30, 2026.

**Attachment:**

**SUBMITTED BY:** 

**SUPERVISOR:**   
Lorena Garcia (Apr 2, 2026 16:49:20 CDT)

For further information contact:  
Name: Mr. Ruben Trevino, Executive Director for  
Facilities, Maintenance, and Operations  
Office: (956) 632-3200  
email: ruben.trevino@mcallenisd.net

**Approved for presentation to the Board of Education:**

  
RENE GUTIERREZ (Apr 2, 2026 18:00:15 CDT)

**RECOMMENDED VENDORS**  
**Request for Proposal No. 2025-1027**  
**Building and Maintenance, Materials, Supplies, Equipment, and Related Services (Round 4)**

<b>No.</b>	<b>Vendor Name</b>	<b>City</b>	<b>State</b>	<b>Recommendation</b>
1	Filterbuy Incorporated	Talladega	AL	Qualified
2	Global Equipment Company Inc.	Port Washington	NY	Qualified
3	Sunsational Solutions (Ten Twenty-Four Industries, LLC)	Austin	TX	Qualified
4	WinSupply RGV Tx Co.	Mission	TX	Qualified

**BOARD AGENDA REPORT**  
**MCALLEN INDEPENDENT SCHOOL DISTRICT**

**MEETING DATE:** April 14, 2026

**SUBJECT:** Discussion and Possible Action on Request for Proposal No. 2026-1029 Fresh Produce for Child Nutrition Program

**REFERENCE:** Goal 1 - Student Achievement/Student Focus; Strategy 7 - Financial Priorities

**BACKGROUND INFORMATION/REASON FOR BOARD CONSIDERATION:**

The McAllen Independent School District solicited proposals for fresh produce to provide students participating in the National School Lunch Program (NSLP) with top-quality, fresh fruits and vegetables.

Participating suppliers are required to meet all food safety standards as well as health code requirements. Due to the volatile nature of produce, pricing for the week of February 16, 2026 through February 20, 2026, was evaluated to complete a cost analysis, to comply with Texas Department of Agriculture (TDA) requirements.

**ADMINISTRATIVE CONSIDERATIONS/FACTS AND ANALYSIS:**

One hundred twenty-six (126) vendors were invited to submit proposals, and six (6) vendors responded. On March 31, 2026, the evaluation committee, comprised of Sonia Y. Esquivel, Director of Child Nutrition; Liz Montes, Child and Nutrition Program Procurement Specialist; Laura Williams, Director of Purchasing Services; Elizabeth Cabrera, Coordinator for Purchasing Services, and Carol Quintanilla, Senior Buyer evaluated the proposals.

**LEGAL REVIEW:**

None required.

**BUDGETARY CONSIDERATIONS:**

Funds for these purchases are budgeted through Federal Funds.

**RECOMMENDED BOARD ACTION:**

Administration recommends that the Board of Trustees approve Request for Proposal No. 2026-1029 Fresh Produce for Child Nutrition Program and award the vendors on the attached list, for a period of one (1) year, with the option to renew for four (4) additional one-year terms.

**Attachment:**

**SUBMITTED BY:**   
Sonia Esquivel (Apr 2, 2026 17:55:54 CDT)

**SUPERVISOR:**   
Lorena Garcia (Apr 2, 2026 17:56:46 CDT)

For further information contact:  
Name: Mrs. Sonia Y. Esquivel, Director of Child Nutrition  
Office: (956) 632-3226  
eMail: [sonia.esquivel@mcallenisd.net](mailto:sonia.esquivel@mcallenisd.net)

**Approved for presentation to the Board of Education:**

  
RENE GUTIERREZ (Apr 2, 2026 18:04:07 CDT)

21

**Superintendent of Schools**

**RECOMMENDED VENDORS**

**Request for Proposal 2026-1029 Fresh Produce for Child Nutrition Program**

<b>NO.</b>	<b>VENDOR NAME</b>	<b>CITY</b>	<b>STATE</b>	<b>RECOMMENDATION</b>
1	Brothers Produce	Houston	TX	Qualified
2	Brothers Food Service (Brothers Produce of Austin, Inc.)	Austin	TX	Qualified
3	Buster Lind Produce Inc	Edinburg	TX	Qualified
4	Labatt Food Service LLC (Labatt Institutional Supply Company)	San Antonio	TX	Qualified
5	Nicho Produce Co., Inc.	Edinburg	TX	Qualified
6	Verdant Exchange (Aspire Staffing Incorporated)	Edinburg	TX	Qualified

**EVALUATION MATRIX**

**PROJECT NO./NAME: RFP 2026-1029 Fresh Produce for Child Nutrition Program**

**EVALUATION MEETING DATE: March 31, 2026 at 10:30 a.m.**

No	Criteria	Max. Pts. 100	Brothers Produce Houston, TX	Brothers Produce of Austin, Inc. dba Brothers Food Service Austin, TX	Buster Lind Produce Inc Edinburg, TX	Labatt Food Service San Antonio, TX	Nicho Produce Inc Edinburg, TX	Verdant Exchange Edinburg, TX
	<b>Total Points</b>	<b>100</b>	<b>71.1867</b>	<b>71.2087</b>	<b>59.3025</b>	<b>73.7225</b>	<b>92.5000</b>	<b>68.4336</b>
	<b>Ranking</b>		<b>4</b>	<b>3</b>	<b>6</b>	<b>2</b>	<b>1</b>	<b>5</b>
<b>1</b>	<b>Price</b>	<b>51</b>	<b>29.3128</b>	<b>35.4041</b>	<b>38.0701</b>	<b>30.7116</b>	<b>51.0000</b>	<b>34.2429</b>
	<i>Bid Items (72 of 91) total price for Week of February 16, 2026 - February 20, 2026</i>		\$1,256.49	\$1,040.3117	\$967.46000	\$1,199.26455	\$722.18250	\$1,075.59000
<b>2</b>	<b>Reputation of the vendor and of the vendor's goods or services</b>	<b>3</b>	<b>3</b>	<b>2</b>	<b>0</b>	<b>3</b>	<b>3</b>	<b>2</b>
	<i>Reference Forms = 1 pt ea reference</i>		3 ISD's submitted	2 ISD's	1 incomplete reference form submitted	3 ISD's submitted	3 ISD's submitted	2 ISD's/1 ESC submitted (not ISD)
<b>3</b>	<b>The quality of the vendor's goods or services</b>	<b>20</b>	<b>19.0001</b>	<b>11.3336</b>	<b>0</b>	<b>20</b>	<b>20</b>	<b>11.3336</b>
	<i>Reference Forms</i>							
	<i>Quality of the firm's service (Excellent=1.6667 per reference; Good=.6667 pts per reference; Fair=.3333 pts per reference; Poor=0 pts.)</i>	5	4.0001	2.3334	0.0000	5.0000	5.0000	2.3334
			2 Excellent @ 1.6667 1 Good @ .6667	1 Excellent @ 1.6667 1 Good @ .6667	1 incomplete reference form submitted	3 Excellent @ 1.6667	3 Excellent @ 1.6667	1 Excellent @ 1.6667 1 Good @ .6667
	<i>Timeliness (Excellent=1.6667 per reference; Good=.6667 pts per reference; Fair=.3333 pts per reference; Poor=0 pts.)</i>	5	5	2.3334	0	5	5	2.3334
			3 Excellent	1 Excellent @ 1.6667 1 Good @ .6667	1 incomplete reference form submitted	3 excellent @ 1.6667	3 excellent @ 1.6667	1 Excellent @ 1.6667 1 Good @ .6667
	<i>Continue doing business with vendor (Yes = 1.6667 pts per reference; No = 0 pts)</i>	5	5	3.3334	0	5	5	3.3334
			3 yes	2 yes @ 1.6667	1 incomplete reference form submitted	3 yes	3 yes	2 yes
	<i>Satisfaction (Satisfied = 1.667 pts per reference; Not Satisfied = 0 pts)</i>	5	5	3.3334	0	5	5	3.3334
			3 satisfied	2 satisfied	1 incomplete reference form submitted	3 satisfied	3 satisfied	2 satisfied
<b>4</b>	<b>The extent to which the goods or services meet District's needs</b>	<b>16</b>	<b>16</b>	<b>16</b>	<b>16</b>	<b>16</b>	<b>12</b>	<b>16</b>
	<i>USDA approved facilities</i>	5	5	5	5	5	5	5
	<i>yes = 5 pts; no = 0 pts</i>		Yes	Yes	Yes	Yes	Yes	Yes
	<i>HACCP plan in place</i>	4	4	4	4	4	0	4
	<i>yes = 4 pts; no = 0 pts.</i>		Yes	Yes	Yes	Yes	not submitted	Yes
	<i>Proof of Insurance</i>	3	3	3	3	3	3	3
	<i>yes = 3 pts; no = 0 pts.</i>		Yes	yes	yes	yes	yes	yes
	<i>Current Local Health Department Inspections</i>	4	4	4	4	4	4	4
	<i>yes = 4 pts; no = 0 pts.</i>		yes	yes	yes	yes	yes	yes
<b>5</b>	<b>Past Relationship with District</b>	<b>0</b>	<b>0</b>	<b>0</b>	<b>0</b>	<b>0</b>	<b>0</b>	<b>0</b>
	N/A							
<b>6</b>	<b>HUB</b>	<b>0</b>	<b>0</b>	<b>0</b>	<b>0</b>	<b>0</b>	<b>0</b>	<b>0</b>
	N/A							
<b>7</b>	<b>Total long-term cost to the district to acquire the vendor's goods or services</b>	<b>5</b>	<b>2.8738</b>	<b>3.4710</b>	<b>3.7324</b>	<b>3.0109</b>	<b>5.0000</b>	<b>3.3571</b>
	<i>Annual Cost (48 weeks)</i>		2.8738	3.4710	3.7324	3.0109	5.0000	3.3571
	<i>Weighted distribution based on lowest cost</i>		\$60,311.58	\$49,934.96	\$46,438.08	\$57,564.70	\$34,664.76	\$51,628.32
<b>8</b>	<b>Vendor or the vendor's ultimate parent company or majority owner has its principal place of business in this state or employs at least 500 persons in this state</b>	<b>1</b>	<b>1</b>	<b>1</b>	<b>1</b>	<b>1</b>	<b>1</b>	<b>1</b>
	<i>Located in Texas; Yes = 1 pt; No = 0 pts.</i>		Yes	Yes	Yes	Yes	Yes	Yes
<b>9</b>	<b>Any other relevant factor specifically listed in the request for bids or proposals.</b>	<b>4</b>	<b>0.0</b>	<b>2</b>	<b>0.5</b>	<b>0</b>	<b>0.5</b>	<b>0.5</b>
	<i>Buy American Documentation</i>	3	0	2	0	0	0	0
	<i>Complete/All Domestic = 3 pts; Incomplete = 2 pts.; Not Submitted = 0 pts.</i>		not submitted	submitted (incomplete)	not submitted	not submitted	not submitted	not submitted
	<i>Distributor Location</i>	1	0	0	0.5	0	0.5	0.5
	<i>Within 50 miles of McAllen = .5 pts; Geo Local Farmer (Region 1) Preference = .5 pts; Not within 50 miles of McAllen = 0 pts.</i>		Houston, TX not local farmer	Austin, TX not local farmer	Edinburg, TX not local farmer	San Antonio, TX not local farmer	Edinburg, TX not local farmer	Edinburg, TX not local farmer

**BOARD AGENDA REPORT  
MCALLEN INDEPENDENT SCHOOL DISTRICT**

**MEETING DATE:** April 14, 2026

**SUBJECT:** Board Report Regarding Pre-Kinder through 2nd Grades Literacy Efforts and Student Outcomes

**REFERENCE:** Goal 1- Student Achievement/Student Focus, Strategy 4- Learning Experiences; Goal 2 - People Development, Strategy 1 - Communication, Strategy 2 - Experienced Staff, Strategy 6 - Preparedness; Goal 4 - Financial Priorities

**BACKGROUND INFORMATION/REASON FOR BOARD CONSIDERATION:**

This board presentation provides an overview of the supports in place at McAllen I.S.D. through tier one instruction, interventions, reteach, and enrichment to ensure students enrolled in Pre-Kinder through 2nd grades receive a strong foundation leading up to strong reading comprehension skills and confident learners.

**ADMINISTRATIVE CONSIDERATIONS/FACTS AND ANALYSIS:** None

**LEGAL REVIEW:** None

**BUDGETARY CONSIDERATIONS:** None

**RECOMMENDED BOARD ACTION:** This item is for information purposes only.

**Attachment:**

**SUBMITTED BY:** \_\_\_\_\_

For further information contact:  
Name: Jeanette C. Nino,  
Associate Superintendent for Instructional Leadership  
Office: 956-618-6053  
eMail: jeanette.nino@mcallenisd.net

**SUPERVISOR:**   
\_\_\_\_\_  
Jeanette Nino (Apr 1, 2026 16:08:24 CDT)

**Approved for presentation to the Board of Education:**

  
\_\_\_\_\_  
RENE GUTIERREZ (Apr 1, 2026 16:26:31 CDT)

24

**Superintendent of Schools**

04/01/2026



# K-5 Literacy Foundations

## The Road Ahead to Minimize Learning Gaps

Instructional Leadership

Board Report

Tuesday, April 14, 2026



# WHY THIS MATTERS

A photograph of four diverse children (two boys and two girls) smiling and posing together outdoors. The background is a soft-focus green, suggesting trees or foliage. The children are dressed in casual clothing: a light blue t-shirt, a striped shirt, a yellow t-shirt, and a pink t-shirt.

## The Early Years Set the Trajectory

- **90% of brain development happens before age 5**
- **Vocabulary gap begins early**
- **Early academic gaps compound over time**
- **Strong K-2 instruction = stronger 3-5 performance**



# Middle of the Year Data



# Middle of Year vs Beginning of Year mClass Amplify Data (K-2)

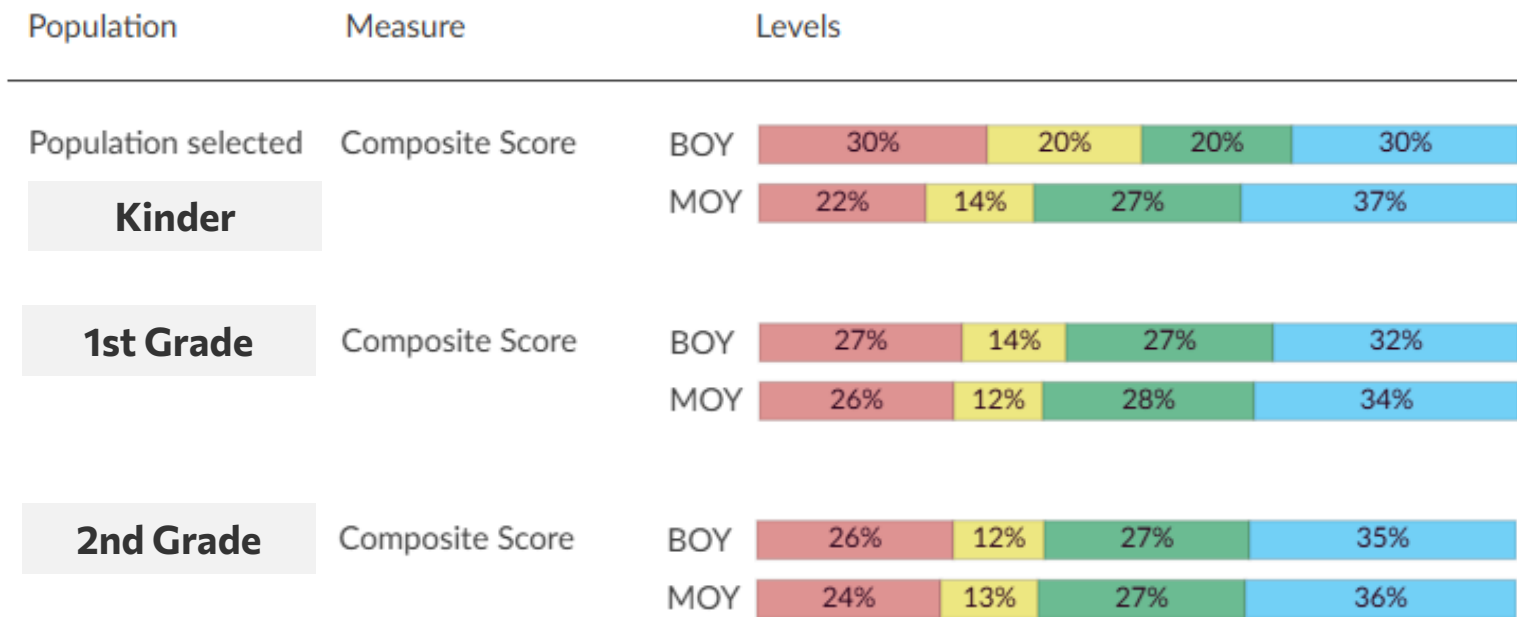

28

Levels:  Well below  Below  At  Above

# Middle of Year vs Beginning of Year iReady Reading Data (3rd – 5th)

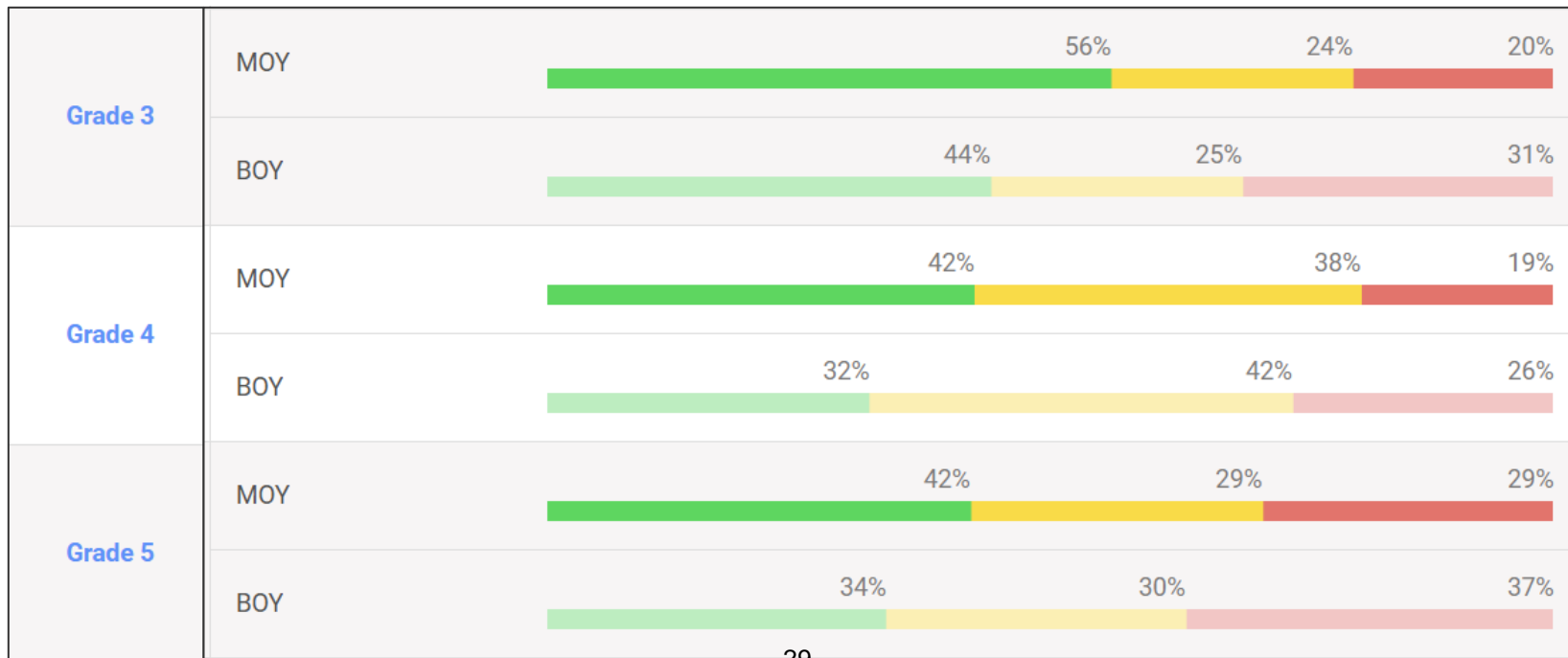

29





# Components of Reading

# The BIG Five!

## Components of Reading

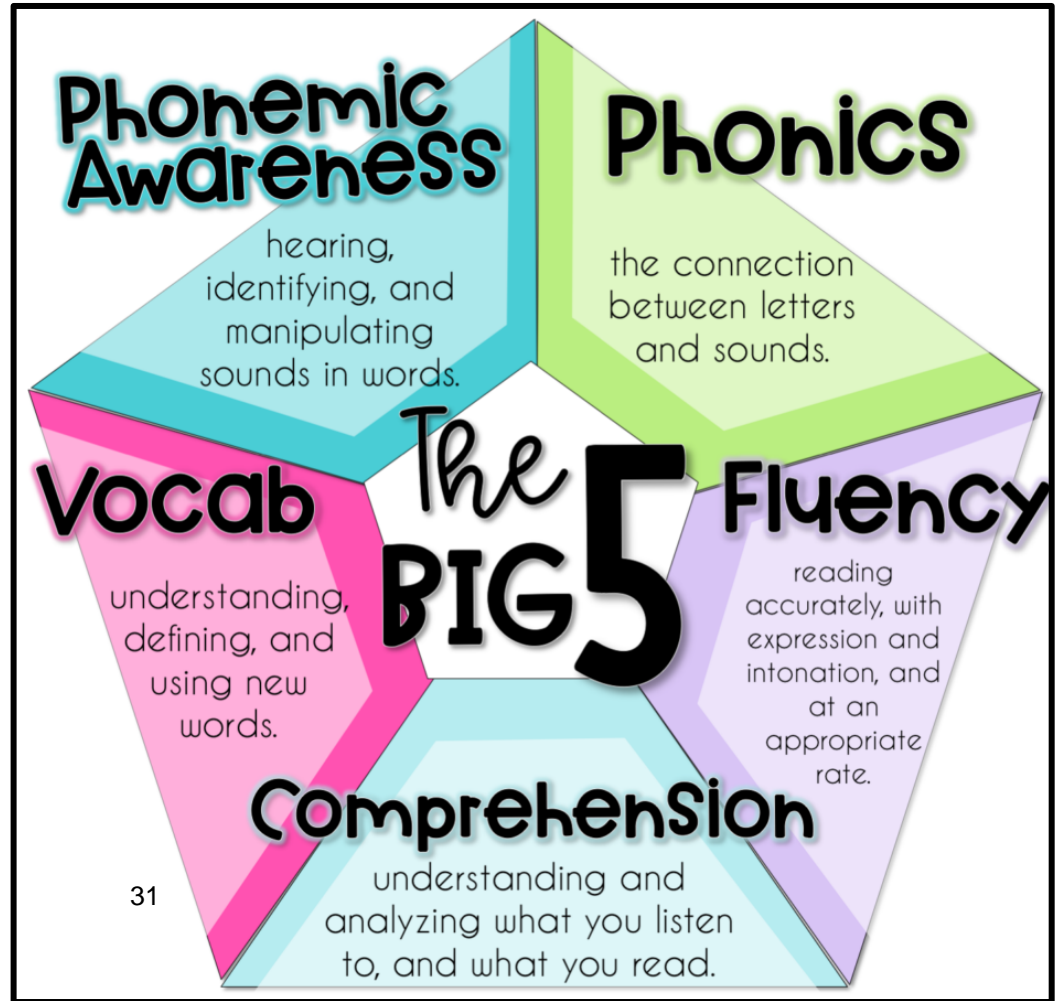

**What STRONG  
instruction looks  
like**





## High Quality Teaching Includes:

- **Explicit Instruction**
  - **Systematic Sequence**
  - **Cumulative practice**
  - **High Student Engagement**
  - **Frequent Checks for Understanding**
  - **DAILY Foundational Skills are NON–Negotiable**
    - **Phonological awareness instruction**
    - **Systematic Phonics**
    - **Decodable Text**
- 

# Mrs. Ortiz – Kinder @ Garza Elementary



# Miss Meza – Kinder @ Garza Elementary



Teacher Table

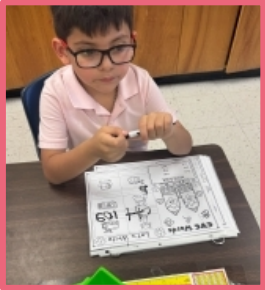
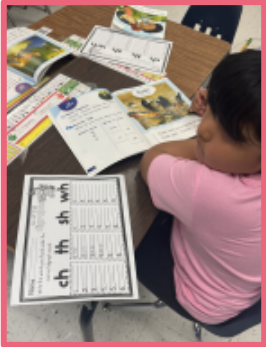

Literacy Centers

# mClass Amplify Data – Garza Elementary

Population	Measure	Levels	Students	
<b>KINDER</b>	Composite Score	BOY		<u>60</u>
		MOY		<u>52</u>
	Population ⚡	Measure	Well below ⚡ Below ⚡ At ⚡ Above ⚡	Students ⚡
<b>TEACHER A</b>	Composite Score	BOY		<u>36</u>
		MOY		<u>29</u>
<b>TEACHER B</b>	Composite Score	BOY		<u>18</u>
		MOY		<u>12</u>
<b>TEACHER C</b>	Composite Score	BOY		<u>36</u>
		MOY		<u>29</u>



# How to Support CONSISTENTLY





## Administrator Assessment-Instructional Cycle

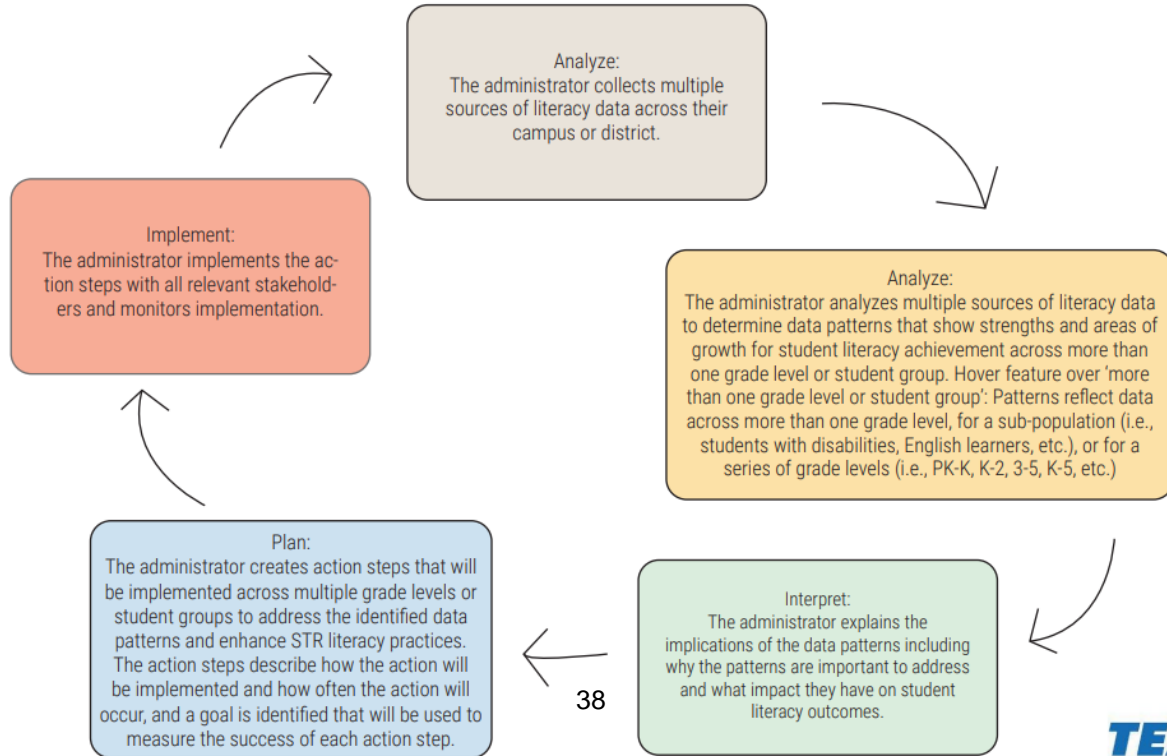



# Plan for the remainder of the school year:

- **Prioritize explicit, systematic instruction**
  - **Clear expectations for high-quality teaching**
  - **Data to identify and respond in a timely manner**
  - **Ongoing coaching & Professional Learning**
  - **Aligned instructional materials**
  - **Actively monitoring instruction**
  - **Fostering a culture of accountability**
  - **Ensuring struggling readers receive targeted, intensive support**
  - **Redirection of Support Staff to the lower grades (after STAAR Assessment)**
- 

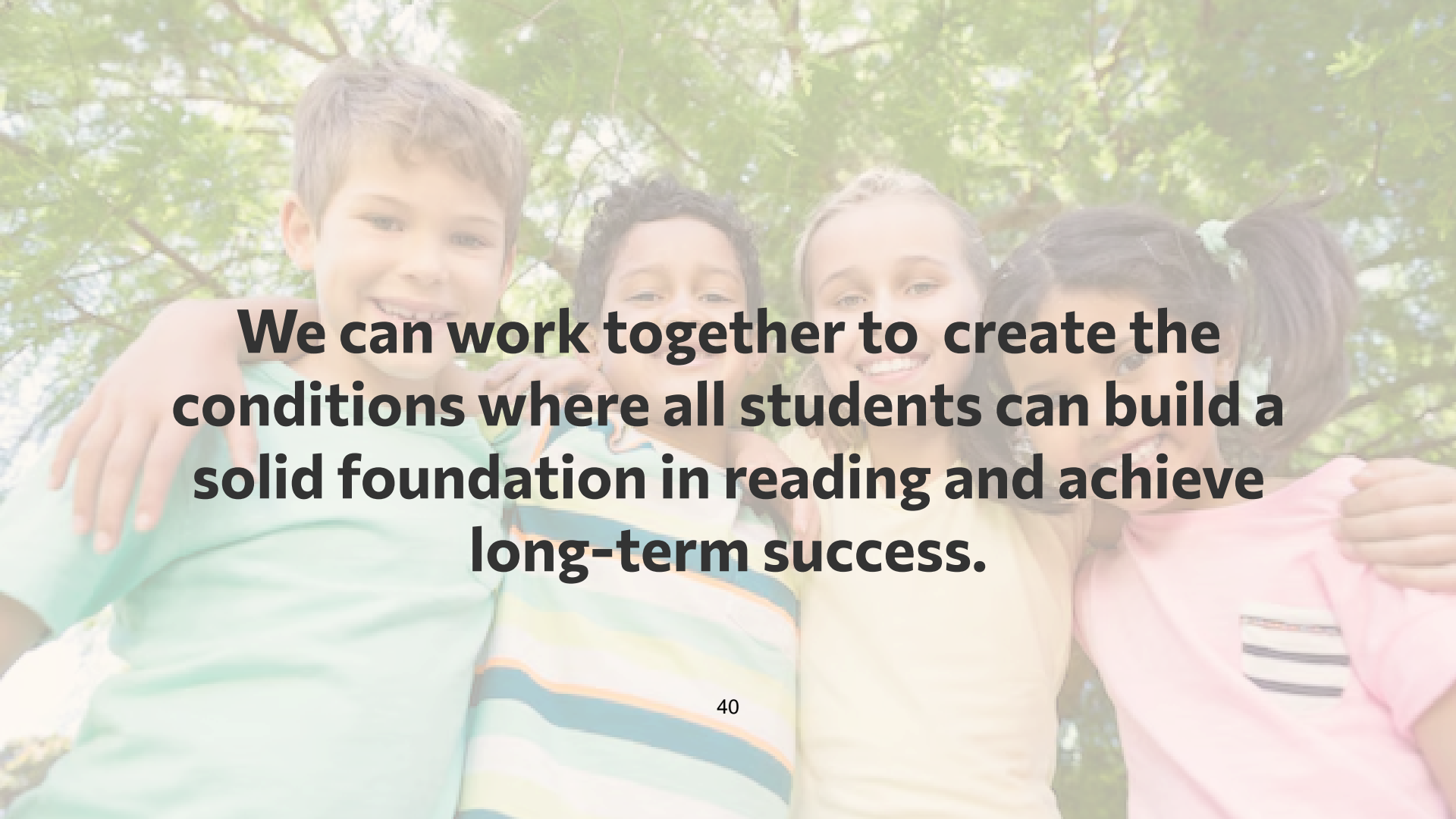
A photograph of four diverse children (two boys and two girls) smiling and posing together outdoors. They are standing in front of a background of green trees. The children are wearing casual clothing: a light green t-shirt, a striped t-shirt, a yellow t-shirt, and a pink t-shirt. The text is overlaid in the center of the image.

**We can work together to create the conditions where all students can build a solid foundation in reading and achieve long-term success.**



# Thank you!

**BOARD AGENDA REPORT  
MCALLEN INDEPENDENT SCHOOL DISTRICT**

**MEETING DATE:** April 14, 2026

**SUBJECT:** Board Report Regarding 2026-2027 McAllen I.S.D. Advanced Scholars Academy at Wilson Elementary

**REFERENCE:** Goal 1- Student Achievement/Student Focus, Strategy 4- Learning Experiences; Goal 2 - People Development, Strategy 1 - Communication, Strategy 6 - Preparedness; Goal 4 - Financial Priorities

**BACKGROUND INFORMATION/REASON FOR BOARD CONSIDERATION:**

McAllen I.S.D. will be launching the Elementary Advanced Scholars Academy August 2026 at Wilson Elementary. This opportunity will be available for current 3rd and 4th graders (rising 4th and 5th graders) at all 18 elementary schools to apply considering enrollment criteria and considerations.

**ADMINISTRATIVE CONSIDERATIONS/FACTS AND ANALYSIS:** None

**LEGAL REVIEW:** None

**BUDGETARY CONSIDERATIONS:** None

**RECOMMENDED BOARD ACTION:** This item is for information purposes only.

**Attachment:**

**SUBMITTED BY:** \_\_\_\_\_

**SUPERVISOR:**   
\_\_\_\_\_  
[Jeanette Nino \(Apr 2, 2026 16:22:30 CDT\)](#)

For further information contact:  
Name: Jeanette C. Nino,  
Associate Superintendent for Instructional Leadership  
Office: 956-618-6053  
eMail: [jeanette.nino@mcallenisd.net](mailto:jeanette.nino@mcallenisd.net)

**Approved for presentation to the Board of Education:**

  
\_\_\_\_\_  
[RENE GUTIERREZ \(Apr 2, 2026 16:35:18 CDT\)](#)

42

**Superintendent of Schools** 04/02/2026

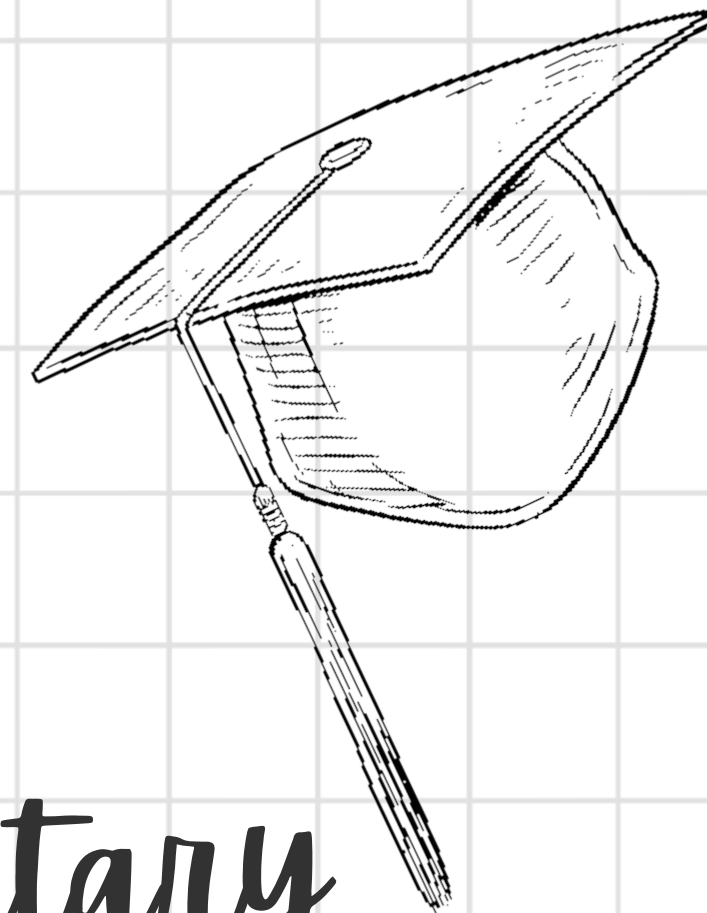
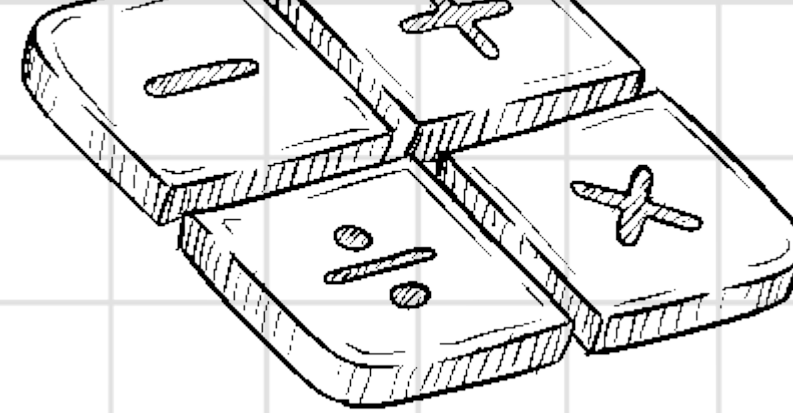
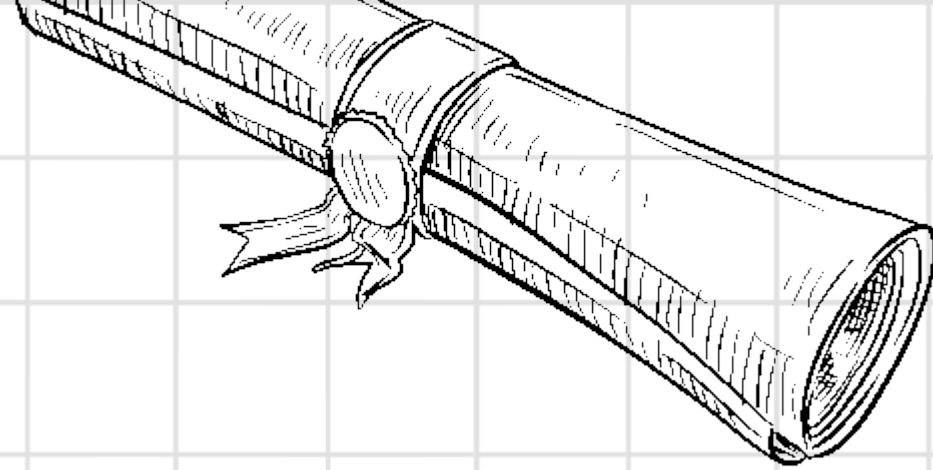
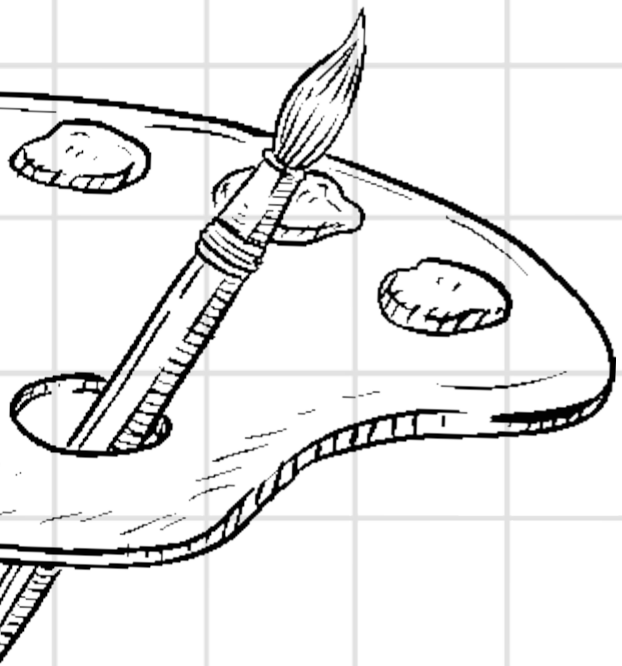

MC<sup>+</sup>ALLEN ISD  
WE ARE <sup>+</sup>ALL IN!

# Elementary Advanced Scholars Academy at Wilson Elementary

Begins Fall 2026 for 4th and 5th Grades

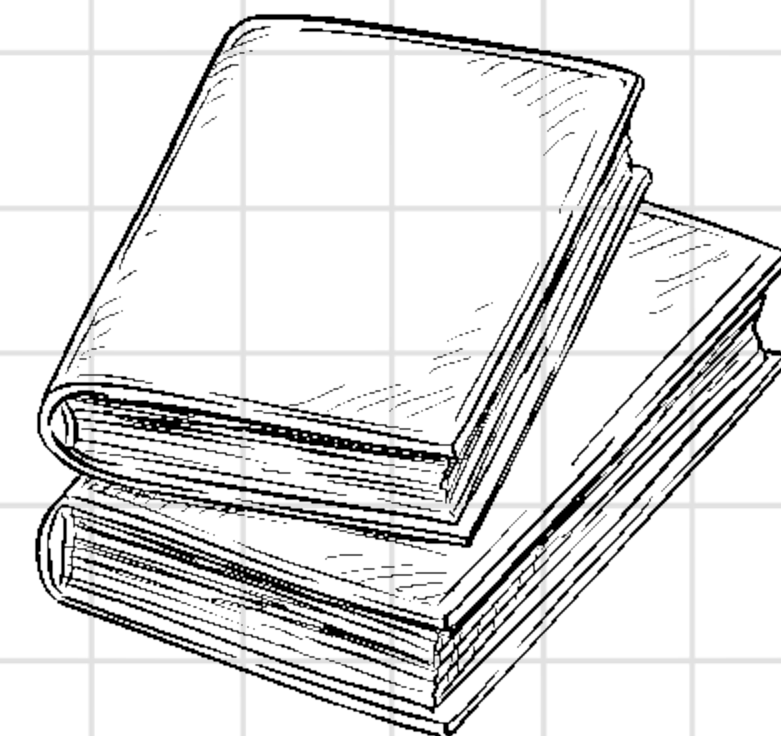

# MCALLEN ISD

## Elementary Advanced Scholars Academy











Elementary students and parents/guardians are invited to attend an Information Session about a first-of-its-kind program at McAllen ISD!

This exciting new opportunity is designed especially for incoming 4th and 5th grade students who are ready to grow, lead, and explore.

**Program Highlights**

-  Development of leadership skills
-  Hands-on creative problem solving
-  Academic opportunities designed to challenge and inspire
-  Participation in exclusive state and national projects
-  A unique teaching and learning experience that supports the whole child to engage in rigorous, competitive learning experiences

**Information Session Dates:**

 Thursday, March 26, 2026  
6-7 pm

 **VIRTUAL: [Google Meet Link](#)**

 Saturday, March 28, 2026  
10-11 AM

**WILSON ELEMENTARY**  
1200 W. Hackberry

For More Information:  956-687-MISD (6473)

# MCALLEN ISD

## Academia de Eruditos Elementales Avanzados











¡Se invita a los estudiantes de primaria y a los padres/tutores a asistir a una sesión informativa sobre un programa único en su tipo en McAllen ISD!

Esta nueva y emocionante oportunidad está diseñada especialmente para estudiantes entrantes de 4º y 5º grado que están listos para crecer, liderar y explorar.

**Aspectos destacados del programa**

-  Desarrollo de habilidades de liderazgo
-  Resolución creativa de problemas de forma práctica
-  Oportunidades académicas diseñadas para desafiar e inspirar
-  Participación en proyectos estatales y nacionales exclusivos
-  Una experiencia de enseñanza y aprendizaje única que apoya a todo el niño para que participe en experiencias de aprendizaje rigurosas y competitivas.

**Fechas de la sesión informativa:**

 Jueves, 26 de marzo de 2026  
6-7 pm

 **VIRTUAL: [Enlace de Google Meet](#)**

 Sábado 28 de marzo de 2026  
10-11 a. m.

**WILSON ELEMENTARY**  
1200 W. Hackberry

Para más información:  956-687-MISD (6473)



# McAllen<sup>+</sup> ISD

WE ARE **ALL** IN!





## Why the Advanced Scholars Academy?

- Unique approaches to teaching and learning
- Whole-child approach to support students with a rigorous, advanced curriculum in all subjects
- Real-world experiences, such as offering a leadership course, applying technology to solve real-world problems, and an instructional problem-based learning framework

“Education is more than classrooms. It’s about knowledge, curiosity, and the tools<sup>46</sup> that help us grow.”

# Program Design

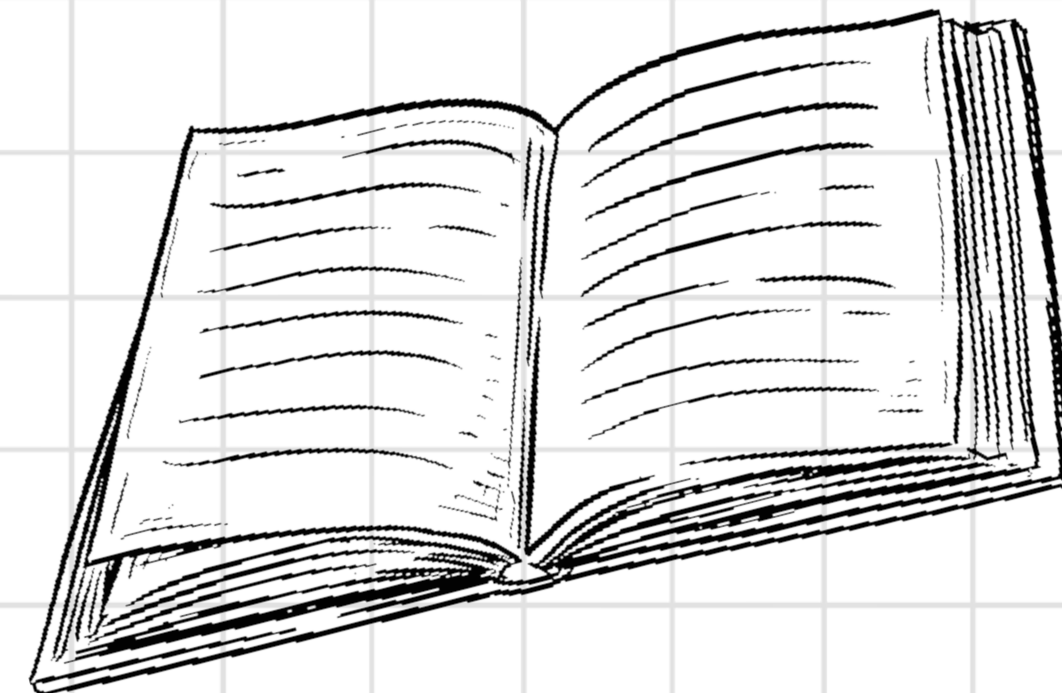

- Students learn best by engaging in balanced, active, and collaborative methods that promote personal growth rather than just high-stakes ranking.
- Key strategies include using purposeful technology (i.e. gamification), interactive group work, and peer-to-peer review.
- Effective competition frames learning as a journey, focusing on effort and improvement.





Fine Arts Program

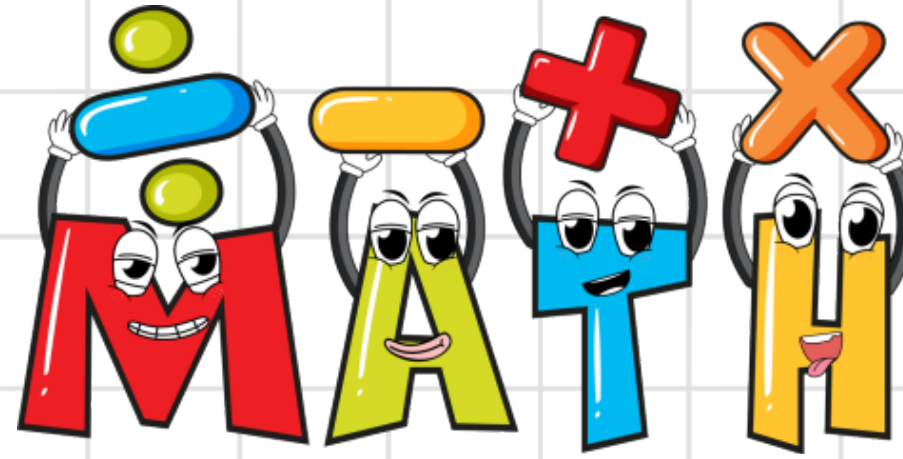

Summer 2026 - Welcome and Orientation  
Summer 2027 - Year 2 Leadership experience

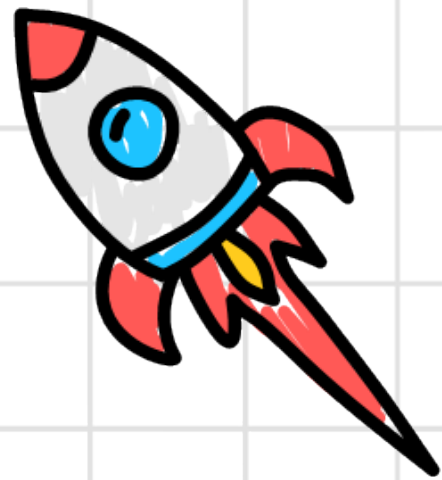

Student Spaceflight Experiment  
Program Opportunity

*Project Based Learning  
Instructional Framework*

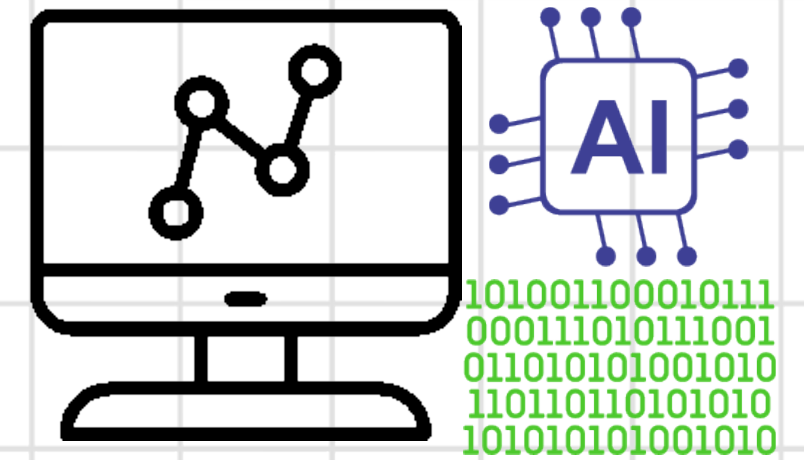

Digital Creators  
and Data Literate

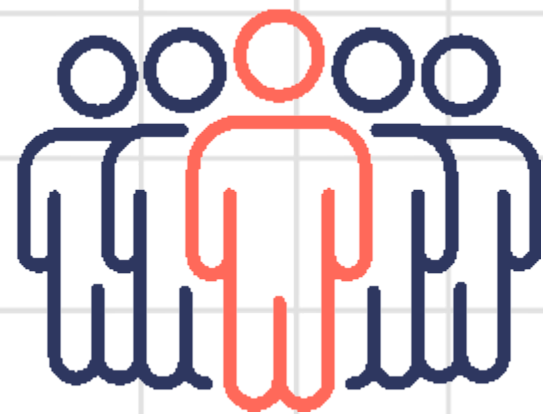

Career Technical Education  
Leadership Course

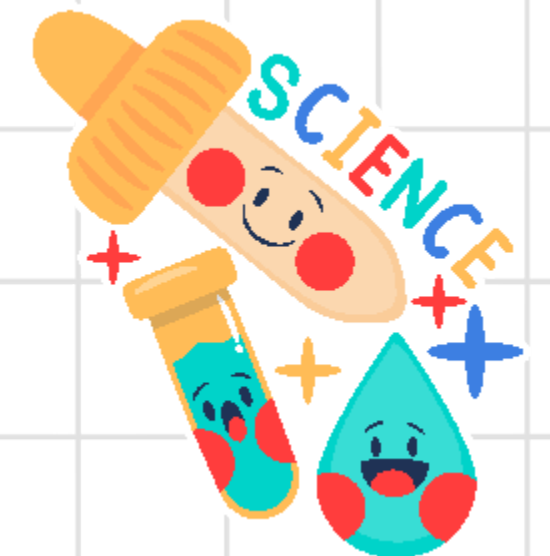

# Student Outcomes and Goals

- 4th grade students will enroll in 4th grade subjects, but will receive instruction throughout the year for 5th grade to accelerate academic preparation.
- 5th grade students will enroll in 5th grade subjects, take the STAAR tests, and will receive instruction throughout the year for 6th grade to accelerate academic preparation.
- Preparation for an advanced academics pathway in middle school and high school
- Create an urgency to offer students a program that will challenge them academically, socially, and emotionally.
- Build leadership skills to network students with community members, faculty, and peers.

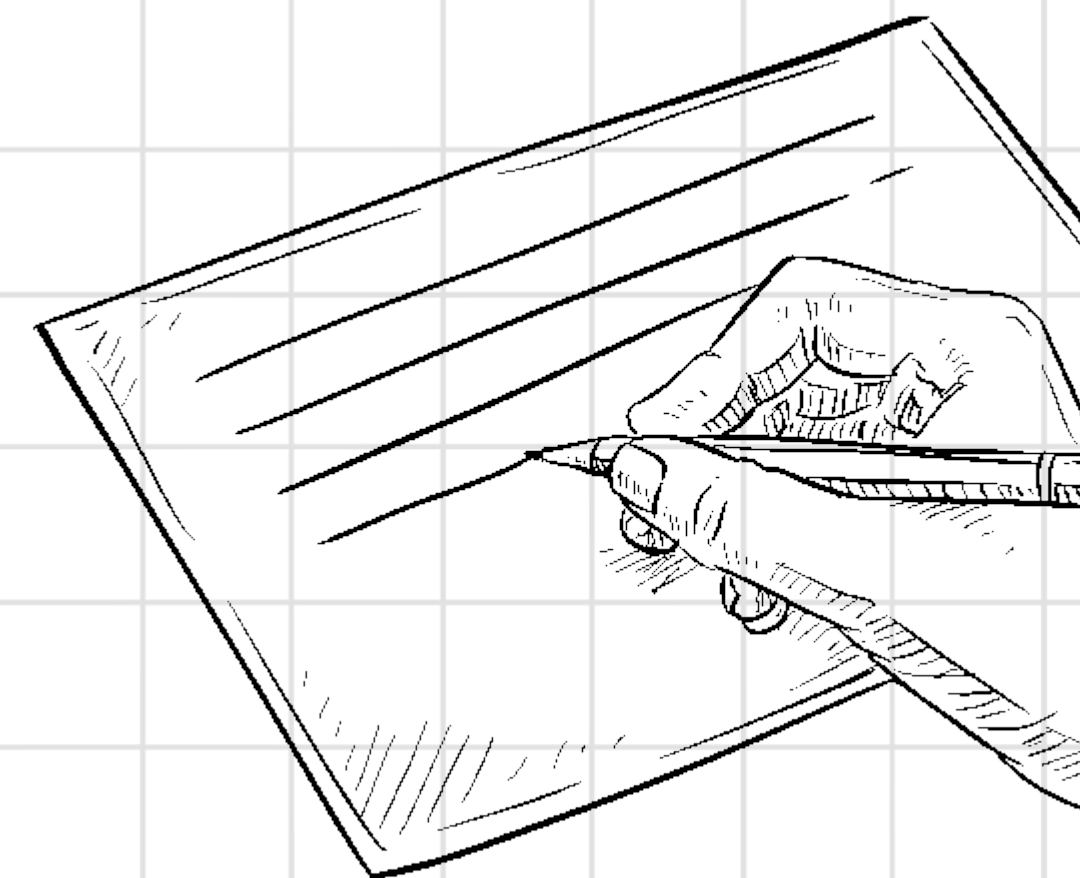
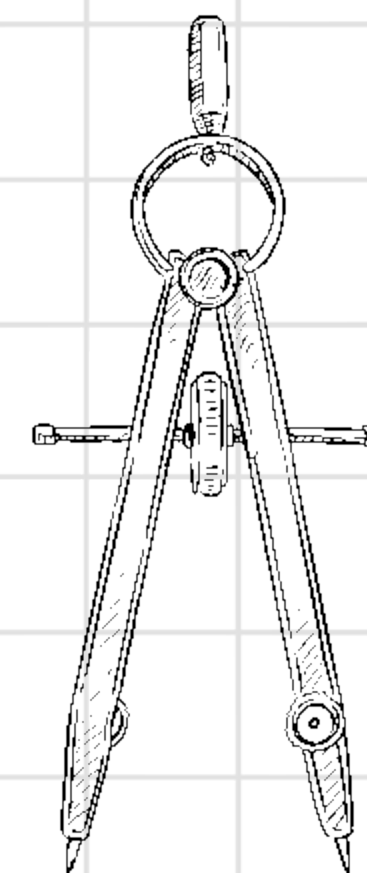
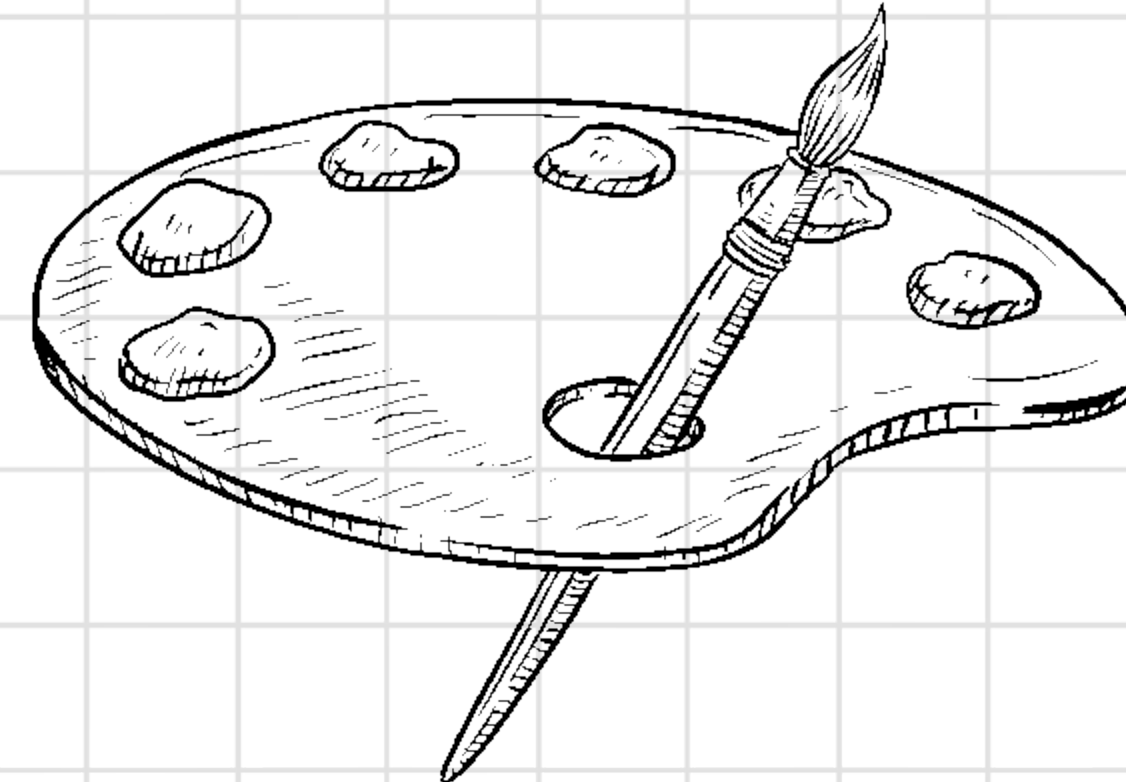

# Student Outcome and Goals

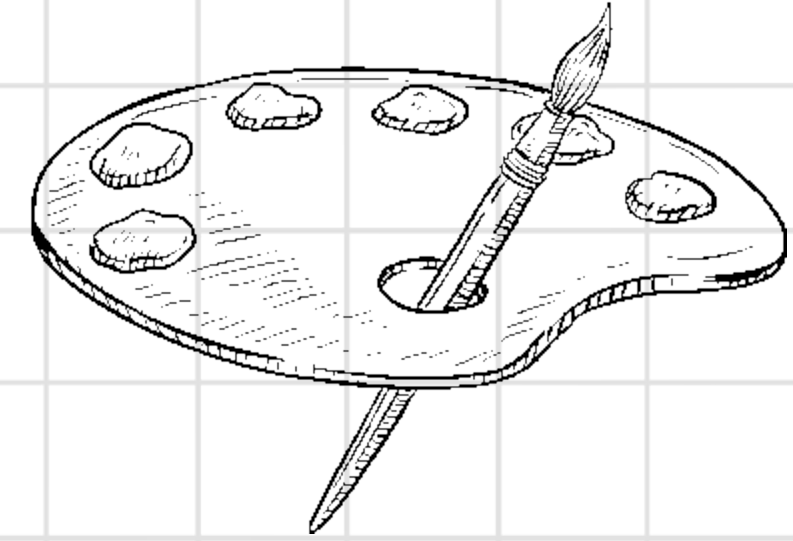

Critical Thinking

Creativity

Confidence

Collaboration/Teamwork

Curiosity

Innovation

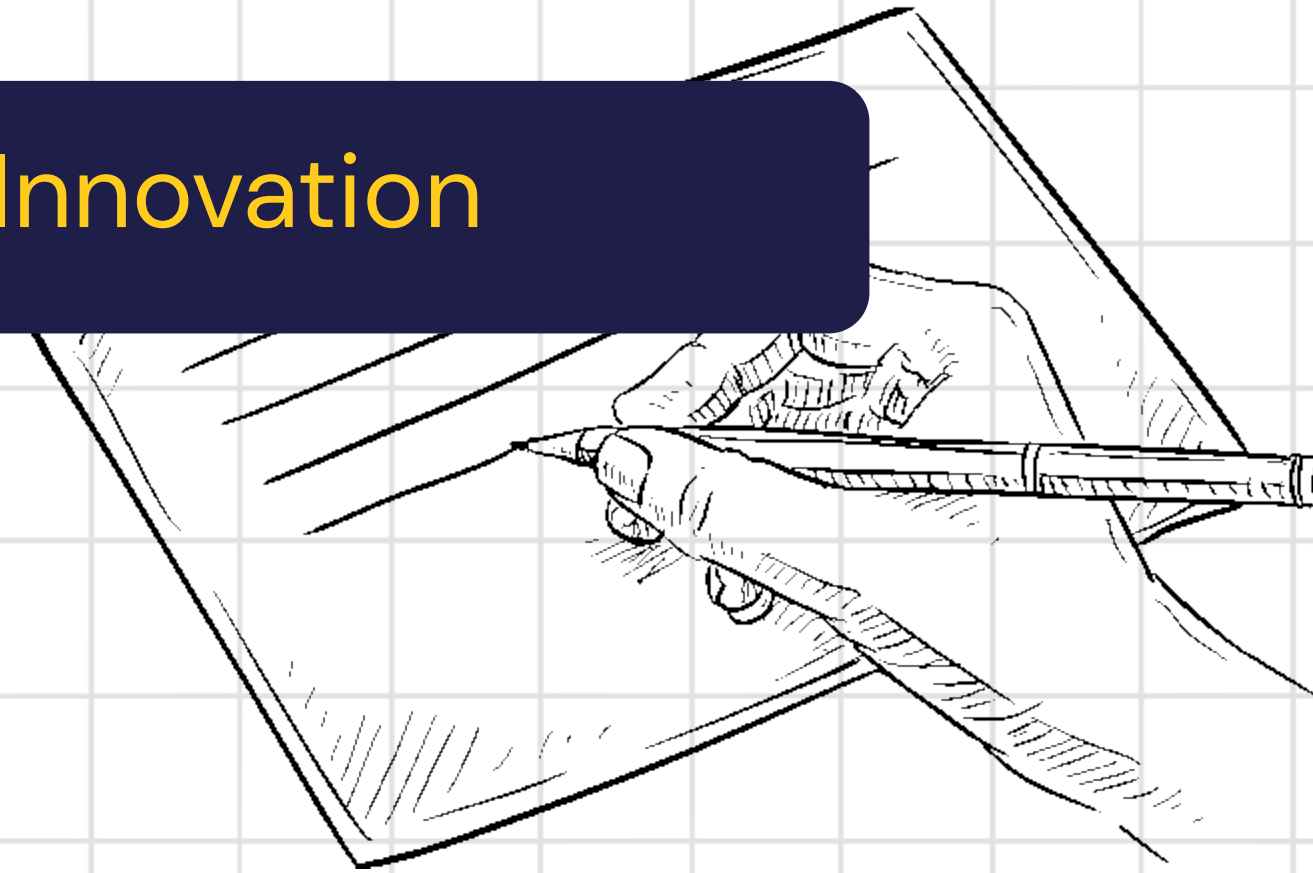
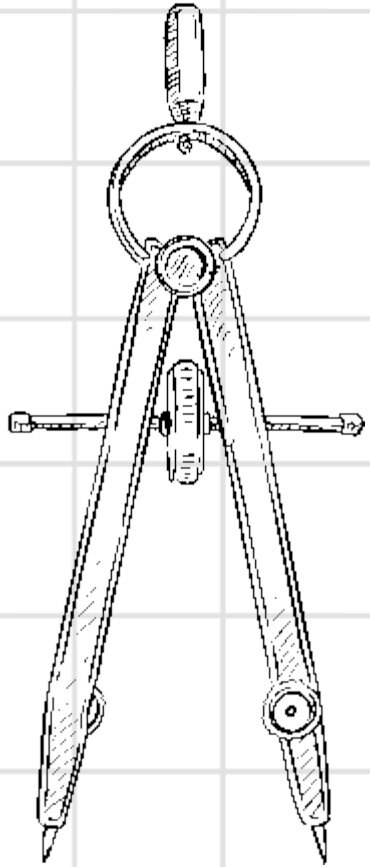

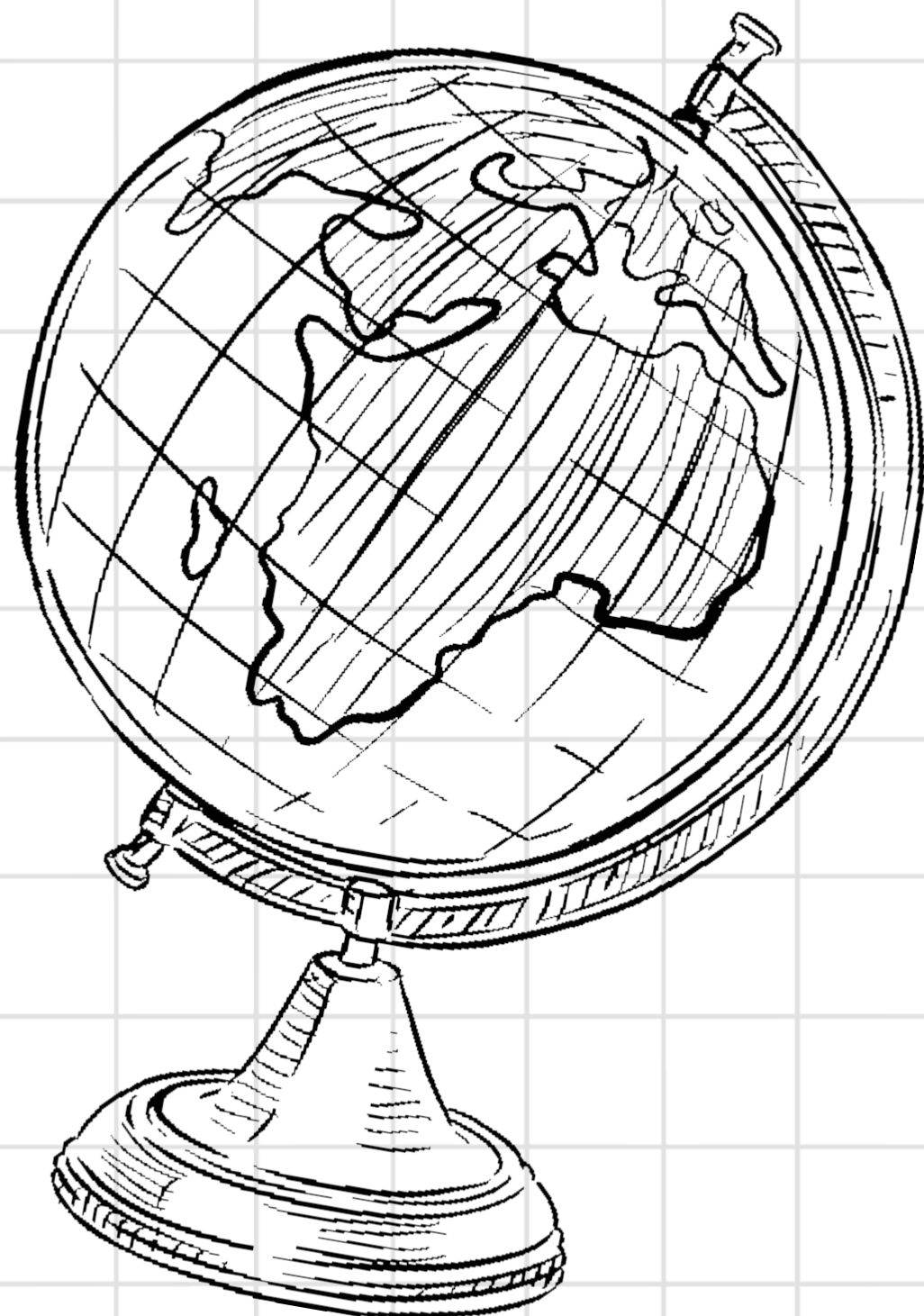

Components of the Academy  
that will Prepare Students  
to Compete with Peers



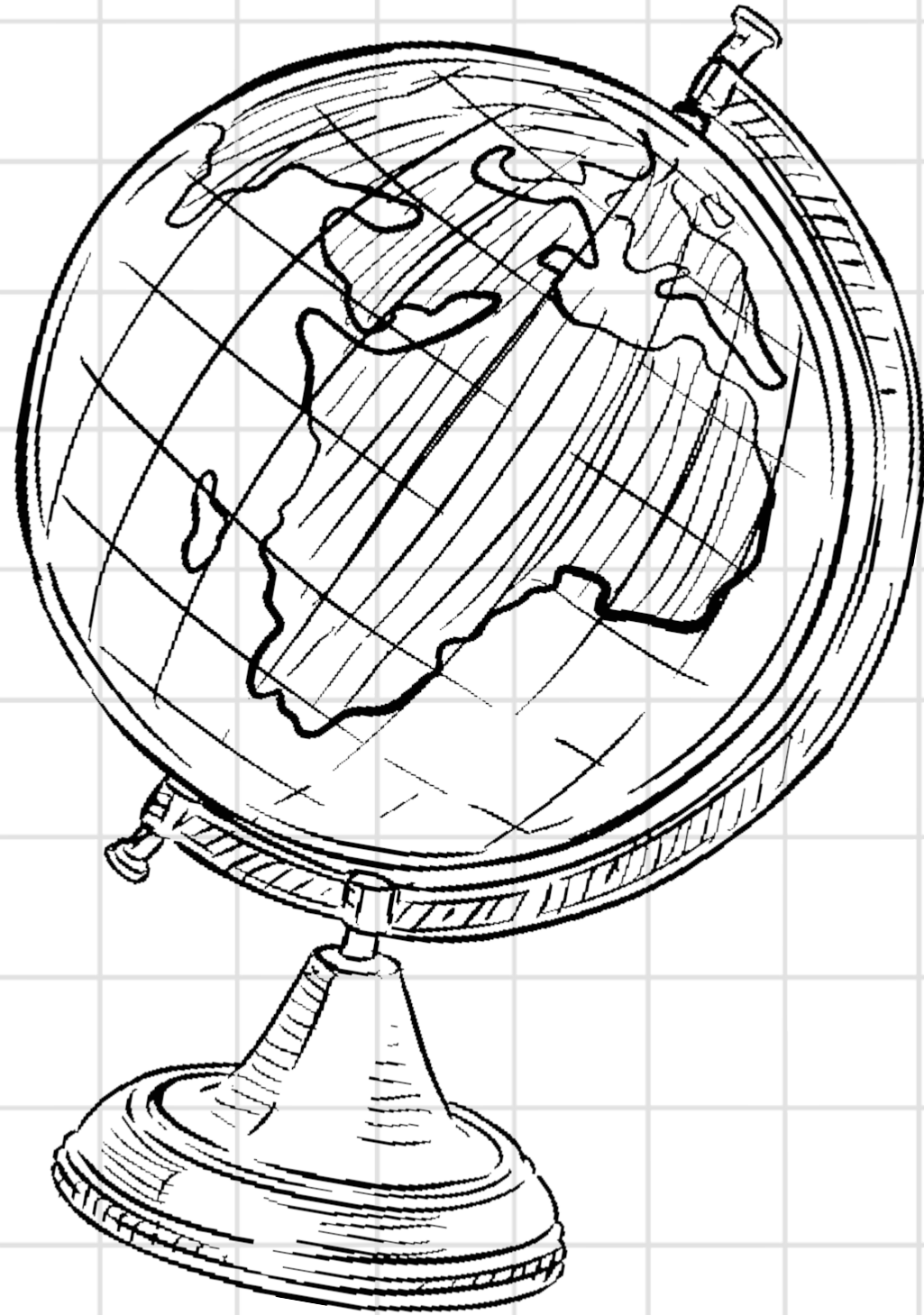

- **Active Learning:** Embed opportunities for an interactive, learning environments that fosters engagement.
- **Balanced Competition:** Avoid high-stakes, constant, or intense comparisons, which can lead to stress or burnout.
- **Structured Collaboration:** Use techniques where students master a topic and teach it to peers, building both individual accountability and group success.
- **Feedback & Reflection:** Implement regular peer reviews with clear rubrics to help students evaluate their own work against others.
- **Growth Mindset:** Encourage viewing mistakes as learning opportunities, focusing on personal development rather than simply beating others.



### Wilson Elementary Advanced Scholars

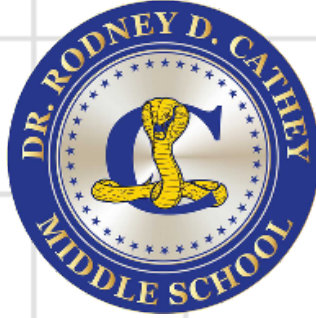
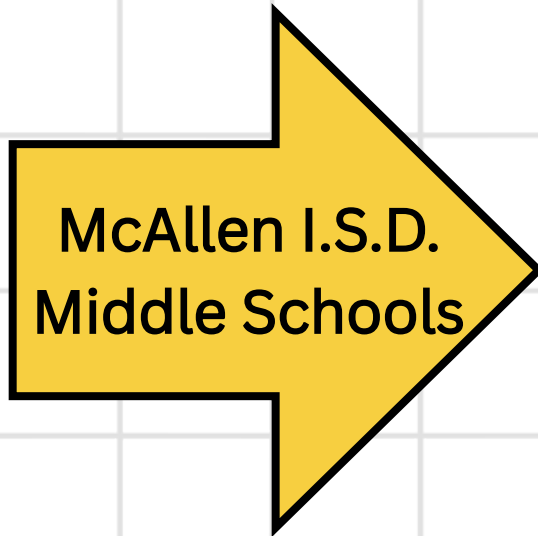

UTRGV  
McAllen ISD  
Collegiate Academy



# Wilson Elementary Advanced Scholars



## Texas Education Agency Graduation Toolkit Endorsements – *Choices*

**Endorsements**

For the first time, students will be able to earn one or more endorsements as part of their graduation requirements. Endorsements consist of a related series of courses that are grouped together by interest or skill set. They provide students with in-depth knowledge of a subject area.

Students must select an endorsement\* in the ninth grade. Districts and charters are not required to offer all endorsements. If only one endorsement is offered, it must be multi-disciplinary studies.

Students earn an endorsement by completing the curriculum requirements for the endorsement, including 4th credit of math and science and 2 additional elective credits.

**Students can choose from 5 endorsement areas**

**Science, Technology, Engineering and Mathematics (STEM)**

- Career and Technical Education (CTE) courses related to STEM
- Mathematics
- Combination of no more than two of the categories listed above

**Business and Industry (one of the following or a combination of areas)**

- Agriculture
- Arts
- Audio/Video
- Finance
- Marketing
- Food and Natural Resources
- Hospitality and Tourism
- Information Technology
- Manufacturing
- Technology Applications
- Architecture and Construction
- Technology and Communications
- Business Management and Administration
- Transportation or Distribution and Logistics
- English electives in public speaking, debate, advanced broadcast journalism, advanced journalism including newspaper and yearbook

**Public Service (one of the following)**

- Human Services
- Law
- Corrections and Security
- Health Science
- Public Safety
- Education and Training
- Government and Public Administration
- Junior Reserve Officer Training Corps (JROTC)

**Arts and Humanities (one of the following)**

- 2 levels each in two languages other than English (LOTE)
- 4 levels in the same LOTE
- Courses from one or two areas (music, theater, art, dance) in fine arts
- English electives not included in Business and Industry
- Social Studies
- American Sign Language (ASL)

**Multi-Disciplinary Studies (one of the following)**

- 4 advanced courses from other endorsement areas
- 4 credits in each foundation subject area, including English IV and chemistry and/or physics
- 4 credits in Advanced Placement, International Baccalaureate, or dual credit selected from English, mathematics, science, social studies, economics, LOTE or fine arts

ENDORSEMENTS

\*Visit your school counselor to learn more about your options.  
Students may earn more than one endorsement.

25

BR14-133-02

# Are there Enrollment Eligibility or Criteria for Students to Consider When Applying for this Academy?

- 1) Recommended for earning a Meets and Masters score on both the 3rd and 4th Grade STAAR Reading Language Arts and Mathematics exams.
- 2) Highly motivated to “think outside the box” from a traditional classroom instructional setting and former learning experiences.
- 3) Work well with others, as this requires collaboration and direction to develop skills in this learning environment.
- 4) Participate in an interview with the Advanced Scholar Academy committee.
- 5) Understand this is a FAMILY investment of time, expanded opportunities, and a commitment to an advanced program.



**McALLEN ISD**  
**Elementary Advanced Scholars Academy**

Elementary students and parents/guardians are invited to attend an Information Session about a first-of-its-kind program at McAllen ISD!

This exciting new opportunity is designed especially for incoming 4th and 5th grade students who are ready to grow, lead, and explore.

**Program Highlights**

- Development of leadership skills
- Hands-on creative problem solving
- Academic opportunities designed to challenge and inspire
- Participation in exclusive state and national projects
- A unique teaching and learning experience that supports the whole child to engage in rigorous, competitive learning experiences

**Information Session Dates:**

Thursday, March 26, 2026  
6-7 pm  
VIRTUAL: [Google Meet Link](#)

Saturday, March 28, 2026  
10-11 AM  
WILSON ELEMENTARY  
1200 W. Hackberry

For More Information: ☎ 956-687-MISD (6473)

# Where May My Child Apply?



<https://mcallenisd.schoolmint.net/>



**McAlLEN ISD**  
**Elementary Advanced Scholars Academy**

Elementary students and parents/guardians are invited to attend an Information Session about a first-of-its-kind program at McAllen ISD!

This exciting new opportunity is designed especially for incoming 4th and 5th grade students who are ready to grow, lead, and explore.

**Program Highlights**

- Development of leadership skills
- Academic opportunities designed to challenge and inspire
- Hands-on creative problem solving
- Participation in exclusive state and national projects

A unique teaching and learning experience that supports the whole child to engage in rigorous, competitive learning experiences

**Information Session Dates:**

Thursday, March 26, 2026  
6-7 pm  
VIRTUAL: [Google Meet Link](#)

Saturday, March 28, 2026  
10-11 AM  
WILSON ELEMENTARY  
1200 W. Hackberry

For More Information: 956-687-MISD (6473)

# Questions, Comments, and Feedback

For more information, contact:

**Student Outreach and Partnerships Department**

**(956) 618-6053**

**Wilson Elementary**

**(956) 971-4525**

**Instructional Leadership Department**

**(956) 618-6053**



**McAlLEN ISD**  
**Elementary Advanced Scholars Academy**

Elementary students and parents/guardians are invited to attend an Information Session about a first-of-its-kind program at McAllen ISD!

This exciting new opportunity is designed especially for incoming 4th and 5th grade students who are ready to grow, lead, and explore.

**Program Highlights**

- Development of leadership skills
- Hands-on creative problem solving
- Academic opportunities designed to challenge and inspire
- Participation in exclusive state and national projects
- A unique teaching and learning experience that supports the whole child to engage in rigorous, competitive learning experiences

**Information Session Dates:**

Thursday, March 26, 2026  
6-7 pm  
VIRTUAL: [Google Meet Link](#)

Saturday, March 28, 2026  
10-11 AM  
**WILSON ELEMENTARY**  
1200 W. Hackberry

For More Information: 956-687-MISD (6473)

**BOARD AGENDA REPORT  
MCALLEN INDEPENDENT SCHOOL DISTRICT**

**MEETING DATE:** April 14, 2026

**SUBJECT:** Discussion and Consideration of Donation on Behalf of Capable Kids and the Wonderful Company for Rayburn Elementary

**REFERENCE:** Goal 1- Student Achievement/Student Focus, Strategy 3-Culture, Strategy 4- Learning Experiences

**BACKGROUND INFORMATION/REASON FOR BOARD CONSIDERATION:**  
Rayburn Elementary National Elementary Honor Society partnered with Capable Kids and the Wonderful Company to support receiving new inclusive play equipment.

**ADMINISTRATIVE CONSIDERATIONS/FACTS AND ANALYSIS:** None

**LEGAL REVIEW:** None

**BUDGETARY CONSIDERATIONS:** None

**RECOMMENDED BOARD ACTION:** Administration is recommending action on this item.

**Attachment:**

**SUBMITTED BY:** \_\_\_\_\_

For further information contact:  
Name: Jeanette C. Nino,  
Associate Superintendent for Instructional Leadership  
Office: 956-618-6053  
eMail: jeanette.nino@mcallenisd.net

**SUPERVISOR:**   
\_\_\_\_\_  
Jeanette Nino (Apr 1, 2026 16:08:02 CDT)

**Approved for presentation to the Board of Education:**

  
\_\_\_\_\_  
RENE GUTIERREZ (Apr 1, 2026 16:25:52 CDT)



# The Inclusive Playground Idea

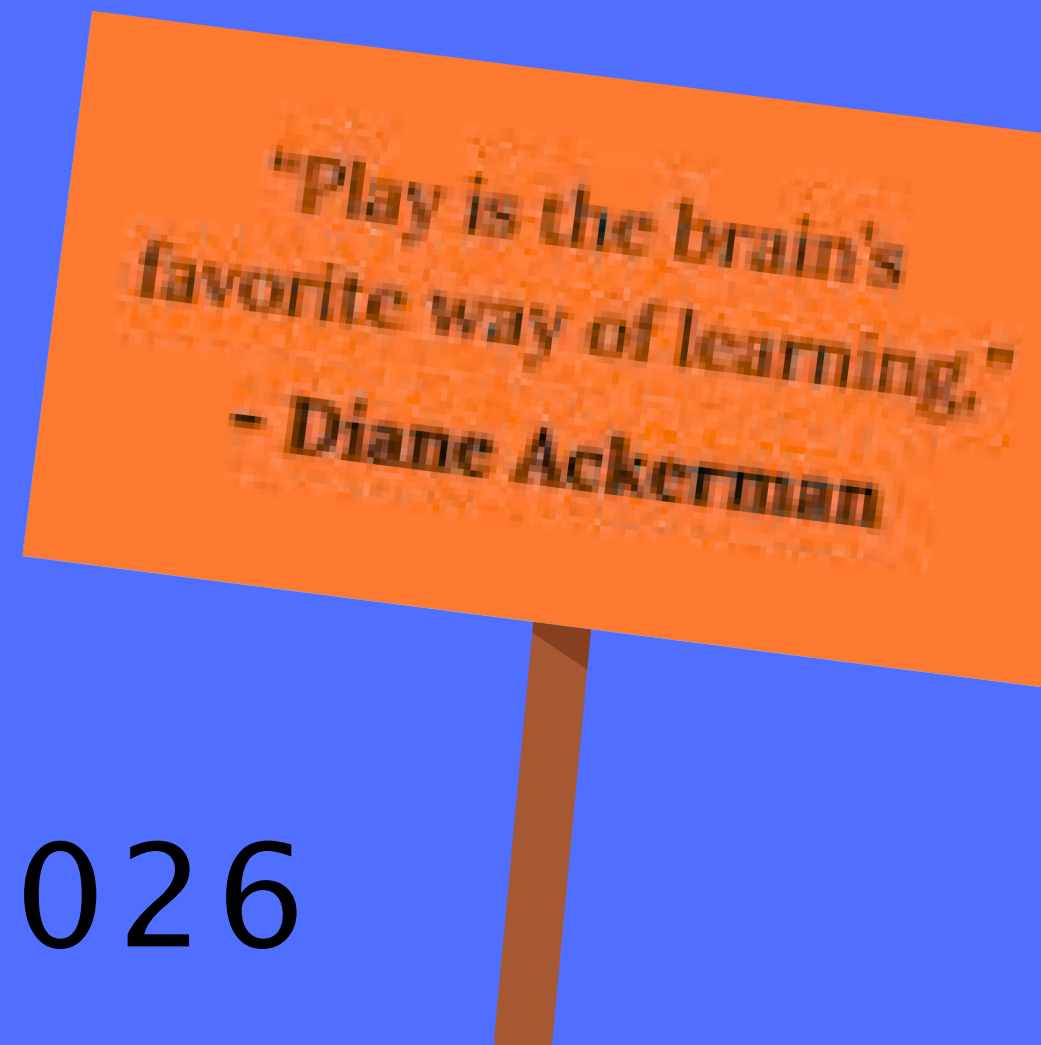
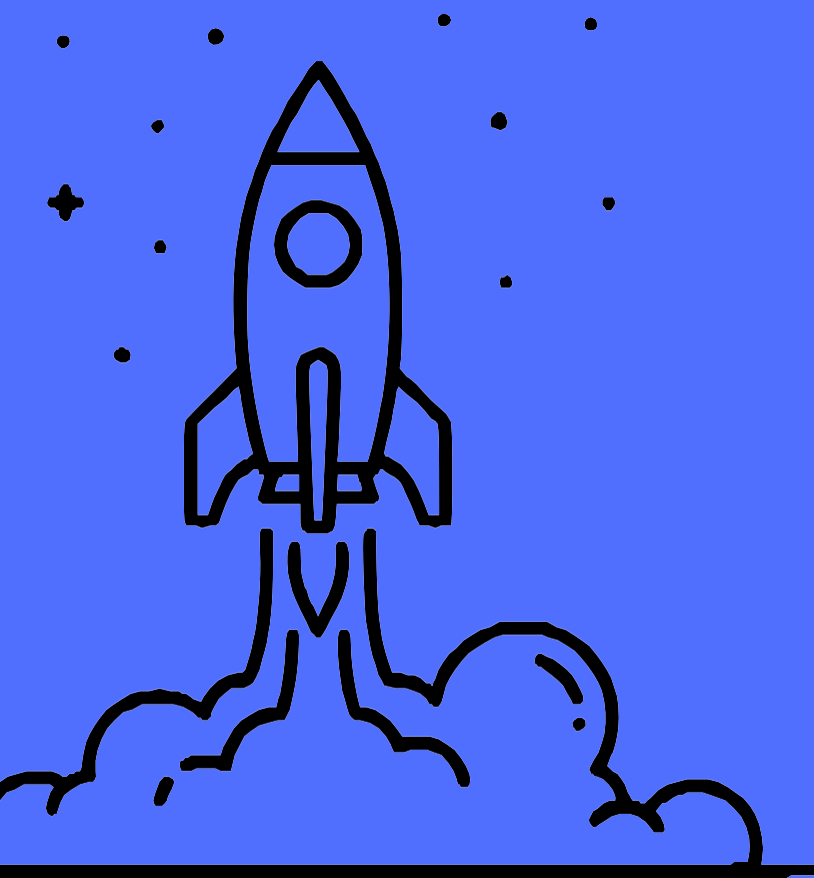

By NEHS members 2025-2026

# About Us:

## About Rayburn:

Rayburn is a place where everyone can learn, have fun, and work together. We solve problems and make changes. Our school has excellent teachers and a strong leadership team led by our amazing principal. Students can grow and get better. Plus, if we have trouble, someone is always there. Everyone has a special place at Rayburn and we can be ourselves and have fun.

Also, Rockets are responsible, kind, and we are leaders.

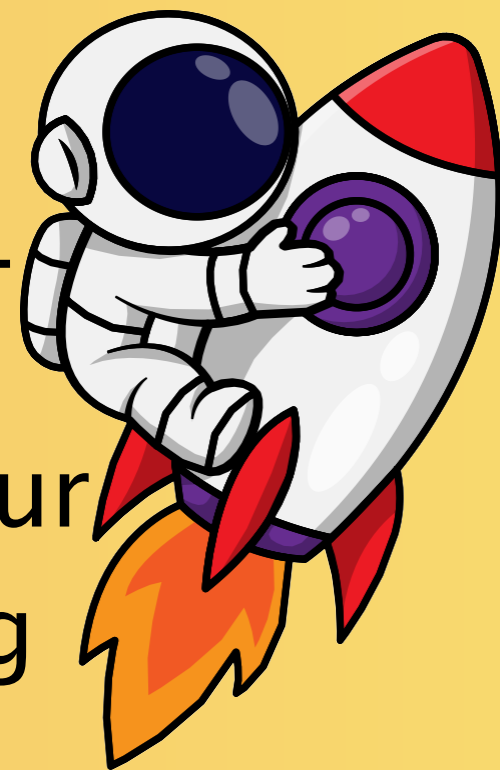

## About NEHS:

Our mission as NEHS members is to make a positive impact on our school and community. NEHS recognizes students for outstanding achievement and character. It's designed from four pillars that encourage scholarship, responsibility, service, and leadership. We solve problems and always set <sup>60</sup>an example for others.

# Our Mission:

We want to provide a place for everyone to play, including kids with different abilities. We want a play space that will give all students opportunities to play with their peers using playground equipment.

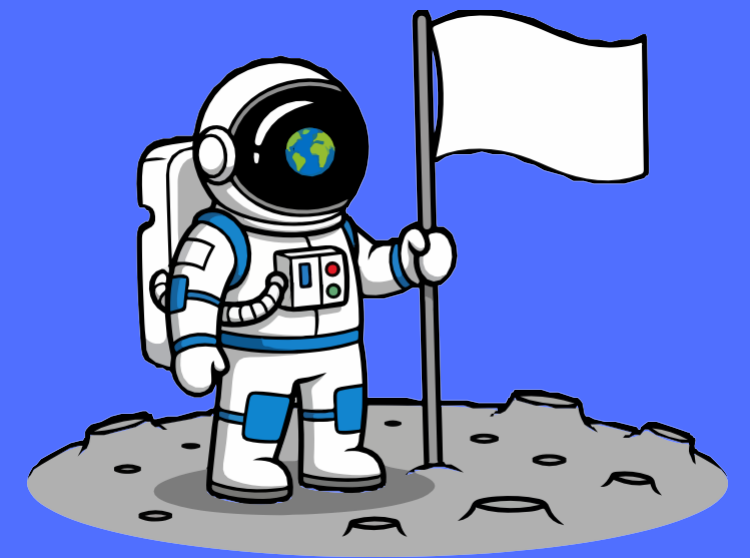

# Exclusive Play/Inclusive Play

## Example Example



# EQUITY VS EQUALITY

**Equality**: means each individual or group of people is given the same resources or opportunities.

**Equity**: recognizes that each person has different circumstances and allocates the exact resources and opportunities needed to reach an equal outcome.

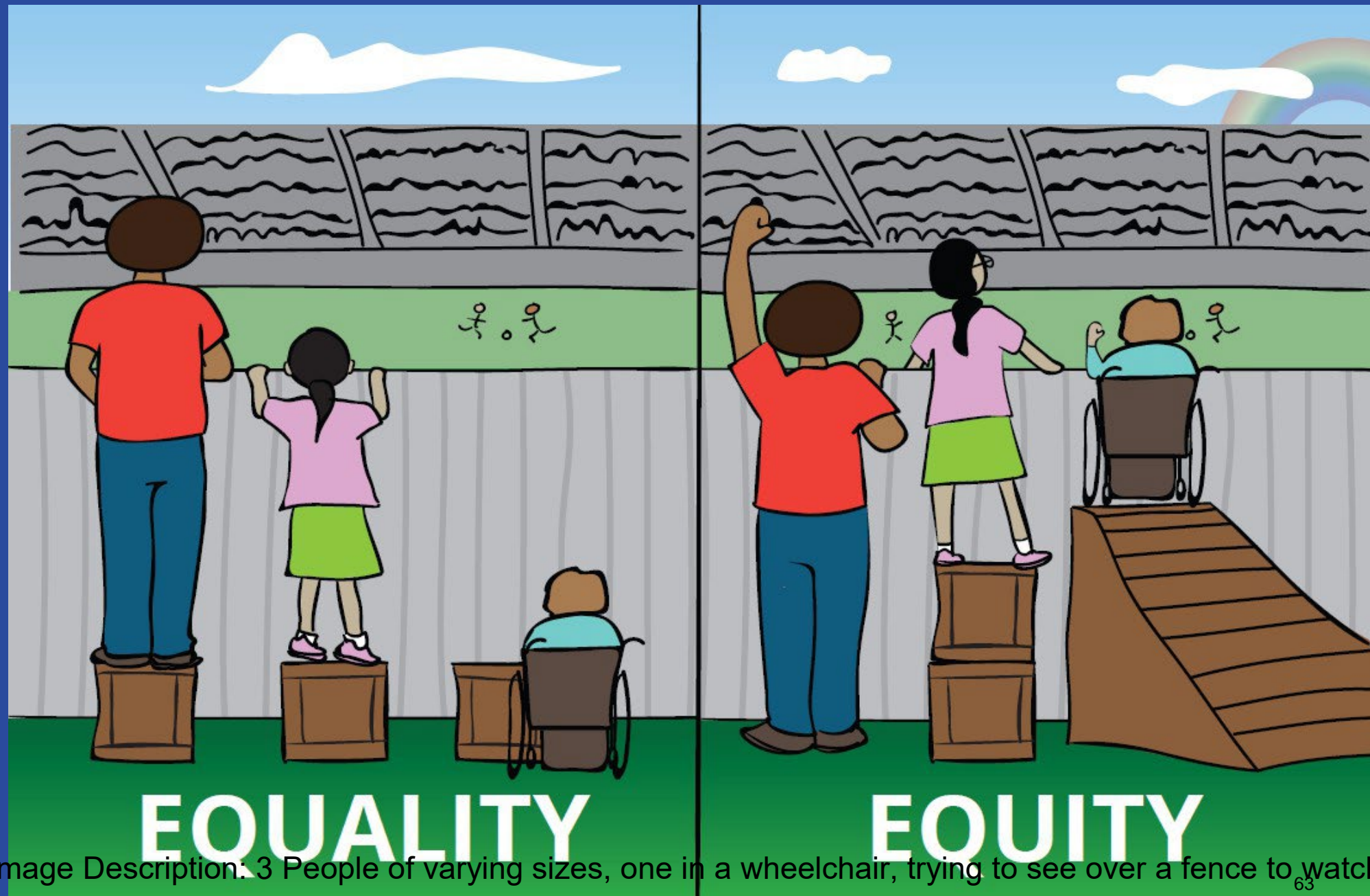

Image Description: 3 People of varying sizes, one in a wheelchair, trying to see over a fence to watch a soccer game. All are given the same-sized wooden box. It is only helpful for some. Picture 2 has each person given a different type of box that helps them see the game.

# DISABILITY IS DYNAMIC AND DIVERSE

We must educate the community on what supports are needed for inclusion while understanding that everyone's experience with a disability is individual.

Image Description: Multiple pictures representing different types of disabilities along with symbols representing disabilities.



# Rayburn Current Enrollment:

All Students - 583

Special Education - 138

504 - 19

**27% of student population**

JEANINE FITZGERALD - THE WOUNDED CHILD  
REGION ONE SPECIAL EDUCATION SYMPOSIUM

Today 51-83%- of children live in distress

Stress > Distress > Trauma

Stress - about perception that you don't have the resources to do what's needed. This is a state of "disease" short term suppresses the immune system

Distress - if you don't relieve stress then distress comes in with disease and can be unrelenting

Trauma - the energy trapped in the brain as a result of an event

STRESS IS NOT A NORMAL STATE OF BEING

Stress is healed indirectly through the senses

## Golden Maximizers:

- Social Support
- Nutrition
- Movement
  - Upside Down
  - Rotary (Spinning)
  - Running (Linear)
  - Oscillation - Up and Down
  - Heavy Work- Lifting/Pulling/Pushing
  - Crashing



*SM* Who benefits from inclusive play

**7,300,000**

school-aged children with disabilities

- U.S. Department of Education, 2021



**1 in 6**

children ages 3-17 with a developmental disability

- CDC, 2022



**1 in 4**

adult Americans with a disability

- CDC, 2023

**16%**

of children ages 5-17 with functional difficulties in at least one area

- Statistics Canada, 2023

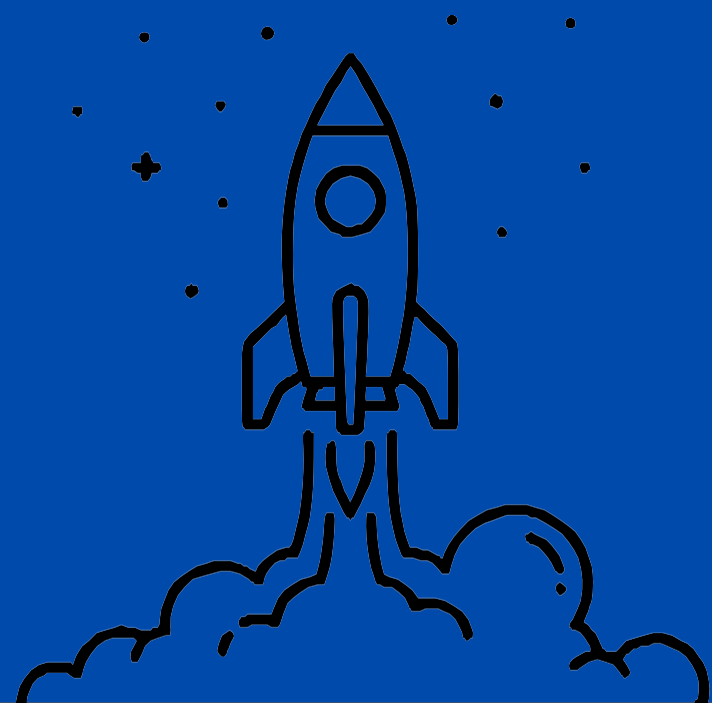

# INCLUSION IS BEAUTIFUL

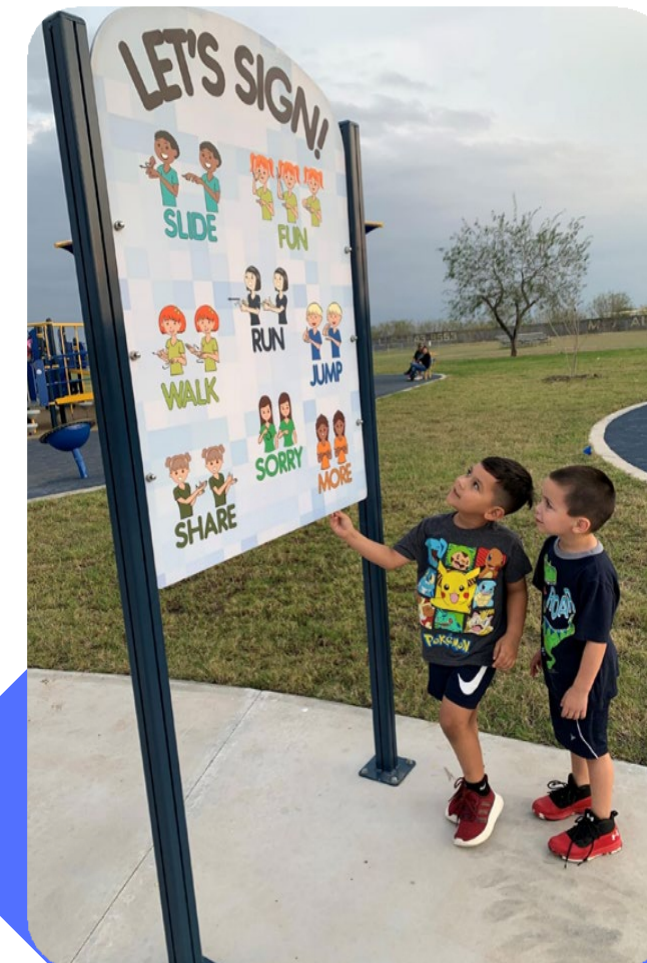

# Phase One of Mission Project:

The project that we are proposing for phase one is beginning with our first inclusive play piece, the OmniSpin Spinner.

*"Play is the brain's favorite way of learning,"*  
- Diane Ackerman



# ROCKETS CHANGING THE WORLD THROUGH PLAY



# PROPOSITION- PHASE 1

- **Partnership**
- **Donation in the amount of \$20,000 to support the Omnispinner purchase**
- **Return on Investment: Priceless**

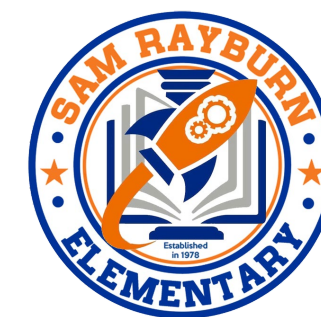





15 THINGS THAT REQUIRE ACCESS

VISITOR  
Andrew Clark

ROBOTS

“If not us, then who?  
If not now, then when?”  
- John Lewis



# LET'S GO ALL IN

You don't have to be an inclusive play expert. You just need to be invested in your community.

We're all in so you can be all in.

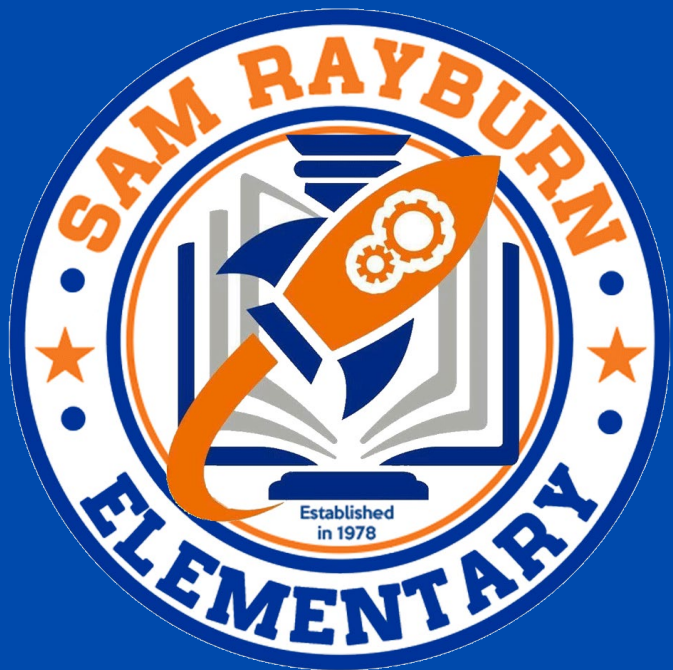

Thank you for supporting  
inclusive play at  
Rayburn Elementary!

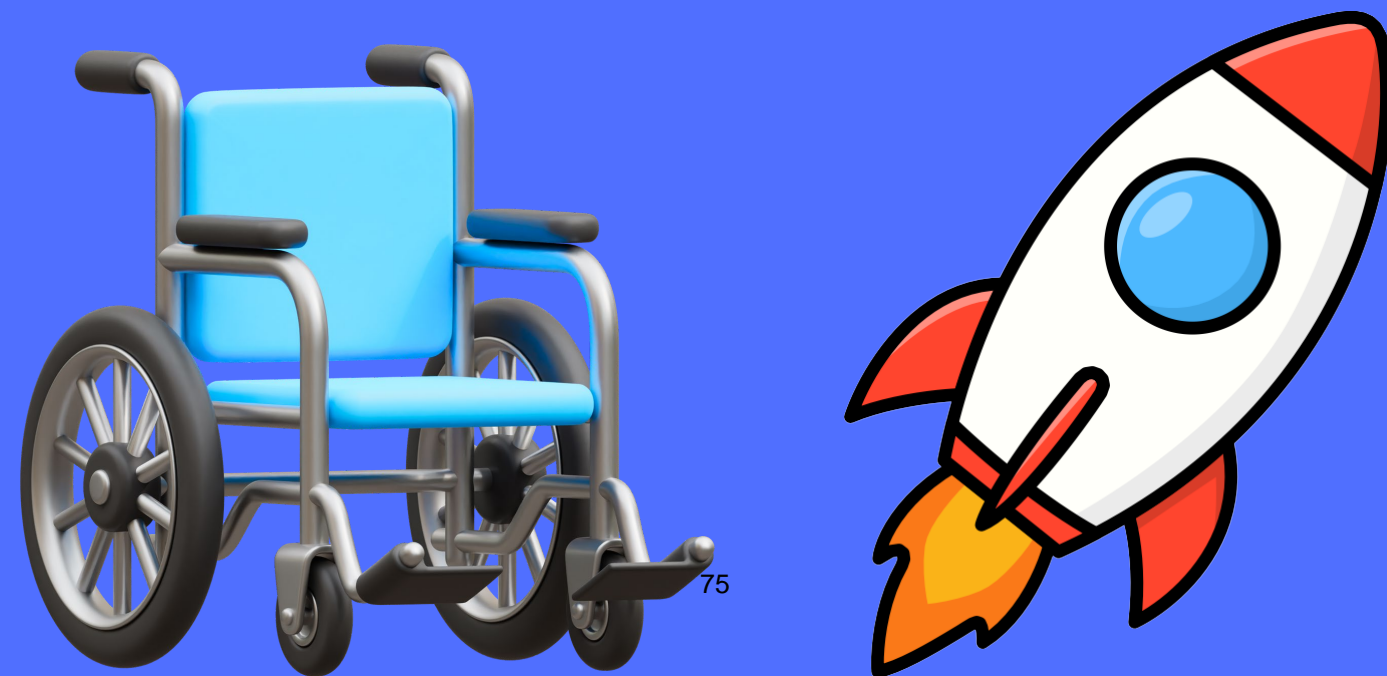

# Credits:

This presentation was made by: Ella, Analeah, Mia, Daniel Z. , Emma, Eliazar, Chanelle, Nayani, Diego, Mrs. Pena, and Mrs. Partida.

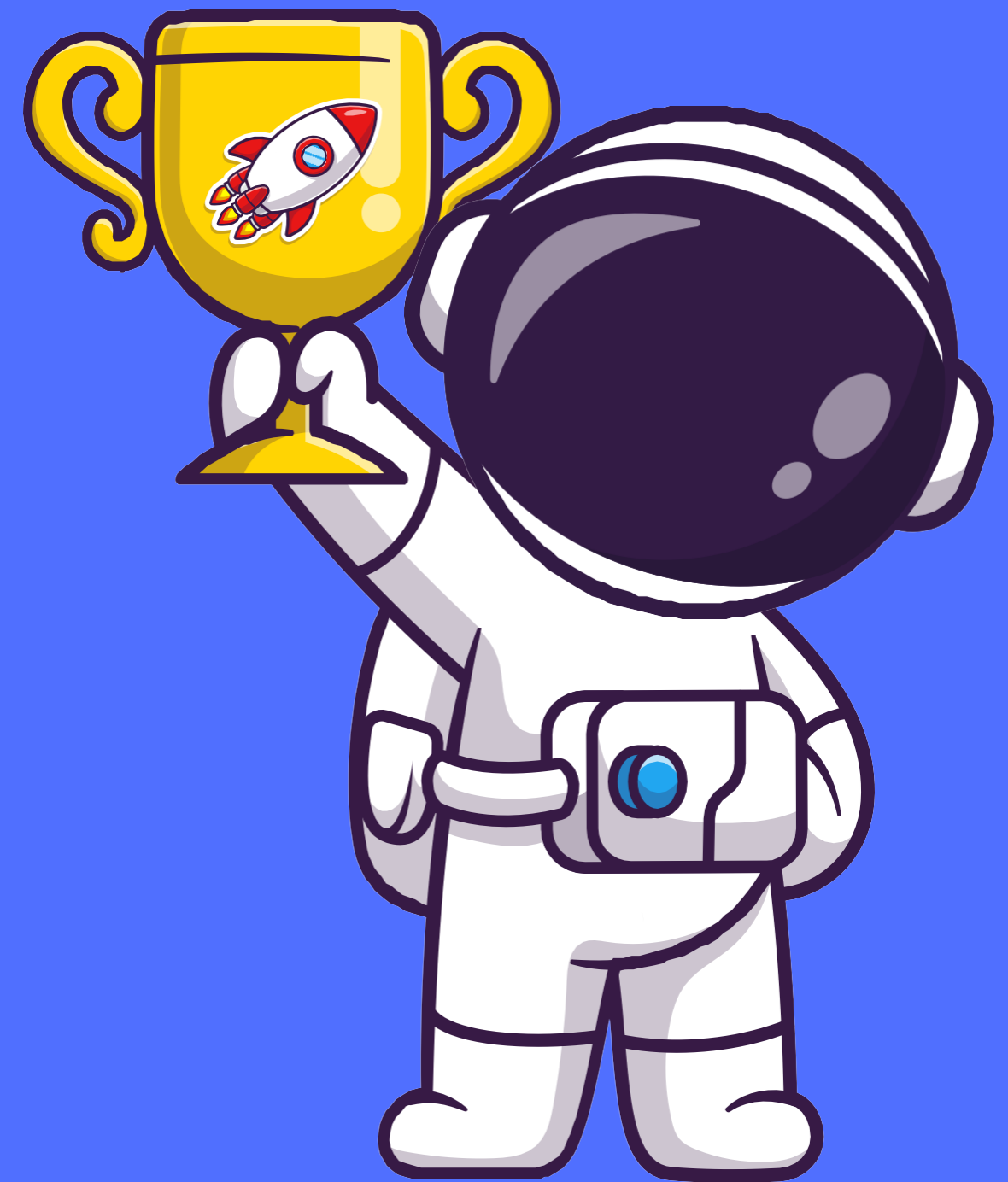

**BOARD AGENDA REPORT  
MCALLEN INDEPENDENT SCHOOL DISTRICT**

**MEETING DATE:** April 14, 2026

**SUBJECT:** Report Regarding the 2026 Bond

**REFERENCE:** Goal 4, Strategy 7 - Financial Priorities

**BACKGROUND INFORMATION/REASON FOR BOARD CONSIDERATION:**

The District has been steadfast in its efforts to provide factual information regarding the 2026 Bond and then to report its progress to the Board of Trustees and the community.

**ADMINISTRATIVE CONSIDERATIONS/FACTS AND ANALYSIS:**

The Board of Trustees has called for a Bond election for May 2, 2026. This report is regarding the District's efforts to provide factual information regarding the 2026 Bond to teachers, parents and community members. The report will also provide an update on the next steps.

**LEGAL REVIEW:**

Not Applicable.

**BUDGETARY CONSIDERATIONS:**

Not Applicable.

**RECOMMENDED BOARD ACTION:**

This report is for information purposes only, requires no Board action.

**Attachment:**

**SUBMITTED BY:**   
FELICIA VILLARREAL (Apr 2, 2026 17:13:07 CDT)

**SUPERVISOR:**   
Alberto Canales (Apr 2, 2026 17:36:17 CDT)

For further information contact:  
Name: Felicia Villarreal, Director Marketing and Communications  
Office: 956-618-6023  
Email: felicia.villarreal@mcallsisd.net

**Approved for presentation to the Board of Education:**

  
RENE GUTIERREZ (Apr 2, 2026 17:56:15 CDT)

# MCA<sup>+</sup> ALLEN ISD

BOND 2026



## Bond Election Communication Timeline

Owned District & Campus Media Strategy



Website:  
[www.mcallenisdbond.org](http://www.mcallenisdbond.org)



Email:  
[bond@mcallenisd.net](mailto:bond@mcallenisd.net)

# Phase 1: Initial Launch

February and March 2026



01

Parent and Faculty Audience:  
25 Faculty, 18 Parents



Face-to-Face Presentations

Digital Mass Communication

03

Mass Communication:  
Direct Messaging to parents and  
staff, social media, digital  
signage, Thrillshare



02

Printed Collateral :  
Posters, brochures, one-pagers, and  
communication pieces



Print Collatoral

Community Outreach

04

Community Outreach Efforts:  
Boys and Girls Club of McAllen,  
McAllen Education Foundation,  
McAllen Housing Authority,



# Phase 2: Education & Engagement

**Week of March 30**

**Week of April 6**

**Print Collateral:  
Vertical Cheat Sheets and One Pagers**

**01**

**Print Collateral:  
Backpack Fliers- Vertical Cheat Sheets & Zero Tax, include voting dates, times and locations**

**01**

**Presentations:  
Campus and Faculty**

**02**

**Presentations:  
Campus, faculty, and large departments**

**02**

**Mass Communication:  
(SM, TS, Scholastic)- Focus on Early Voting Registration (parents, staff, social)**

**03**

**Mass Communication:  
(SM, TS, Marquees, Scholastic)  
Focus on Podcast productions and launching a 7-series outreach effort, Video Launch**

**03**

**Community Outreach:  
Presentation to various community groups, registration to vote made available at large district-hosted events**

**04**

**Community Outreach:  
Presentation to various community groups, DIRECT MAIL PIECES- 20206 One Pager overview,**

**04**

# Phase 3: The Final Countdown

**Week of April 20**

**Week of April 27**

**Print Collateral:**  
 Backpack Fliers- Safety & Security, Fine Arts/CTE,  
 include voting dates, times, and locations

**01**

**Print Collateral:**  
 Backpack Fliers- Bond Overview, include  
 voting dates, times and locations

**01**

**Presentations:**  
 Campus and Faculty, Campus activities  
 are encouraged

**02**

**Presentations:**  
 Within the community, campus activities  
 are encouraged

**02**

**Mass Communication:**  
 (SM, TS, Marquees, Scholastic)  
 Podcast, Safety/Security, Fine Arts/CTE

**03**

**Mass Communication:**  
 (SM, TS, Marquees, Scholastic)  
 Podcast, Bond Overview, voting information

**03**

**Community Outreach:**  
 Presentation to various community groups, DIRECT  
 MAIL PIECES- Letter from Superintendent

**04**

**Community Outreach:**  
 Presentation to various community groups, earned  
 media

**04**

# MCA<sup>+</sup> ALLEN ISD



## BOND 2026

# Thank You

Questions



Website:  
[www.mcallenisdbond.org](http://www.mcallenisdbond.org)

Email:  
[bond@mcallenisd.net](mailto:bond@mcallenisd.net)

**BOARD AGENDA REPORT  
MCALLEN INDEPENDENT SCHOOL DISTRICT**

**MEETING DATE:** April 14, 2026

**SUBJECT:** Discussion and Possible Action on Contract Agreement No. 2026-265 for Election Services and Voting Equipment between the County of Hidalgo and the McAllen Independent School District for the Bond Election on May 2, 2026, with Early Voting to be Conducted from April 20, 2026 through April 28, 2026

**REFERENCE:** Goal 4: Financial Priorities

**BACKGROUND INFORMATION/REASON FOR BOARD CONSIDERATION:**

The McAllen Independent School District has negotiated a service and equipment agreement with the County of Hidalgo. The agreement outlines all services required for an election and includes the use of County's electronic software voting system. The Bond Election is scheduled for Saturday, May 2, 2026 with early voting to be held from April 20, 2026 through April 28, 2026.

**ADMINISTRATIVE CONSIDERATIONS/FACTS AND ANALYSIS:**

Entering into an agreement with the County of Hidalgo County for election services and equipment helps ensure transparency and reduces the potential for concerns regarding bias in the administration of the election.

**LEGAL REVIEW:**

Agreement is pending and will be reviewed once received.

**BUDGETARY CONSIDERATIONS:**

Funds for this project will be secured thru Local Funds.

**RECOMMENDED BOARD ACTION:**

That the Board of Trustees approve Contract Agreement No. 2026-265 for Election Services and Voting Equipment between the County of Hidalgo and the McAllen Independent School District for the Bond Election on May 2, 2026, with Early Voting to be Conducted from April 20, 2026 through April 28, 2026

**Attachment:**

**SUBMITTED BY:**   
Alberto Canales (Apr 8, 2026 14:47:15 CDT)

**SUPERVISOR:** *Lorena Garcia*  
Lorena Garcia (Apr 8, 2026 15:30:10 CDT)

For further information contact:  
Name: Dr. Alberto Canales, Chief Human Resources Officer  
Office: 956-618-6009  
Email: albert.canales@mcallenisd.net

**Approved for presentation to the Board of Education:**

  
RENE GUTIERREZ (Apr 8, 2026 15:38:44 CDT)



Department of Purchasing Services

Contract No.: 2026-265

**Contract Coversheet and Signature Form  
for  
Forms/Contracts Requiring Superintendent Approval**

This form standardizes the contract process and is to be used as the cover sheet to ensure complete review by appropriate department(s)/campus(es).

Human Resources  
Department/Campus Name

<u>Sponsor</u>	<u>Signature</u>	<u>Date</u>
<u>Campus Principal</u>	<u>Signature</u>	<u>Date</u>
<u>Dr. Albert Canales</u>	 <u>Alberto Canales (Apr 9, 2026 17:27:36 CDT)</u>	<u>04/09/2026</u>
<u>Department Director</u>	<u>Signature</u>	<u>Date</u>



WHEREAS, pursuant to Section 43.007 of the Texas Election Code, the COUNTY has approved participation in a **countywide** program. Therefore, countywide/districtwide polling locations will be used for the election held on **MAY 2, 2026**, and any resulting runoff; and

WHEREAS, pursuant to Section 43.007(e), each countywide/districtwide polling location must allow a voter to vote in the same elections in which the voter would be entitled to vote in the county election precinct in which the voter resides; and

WHEREAS, ELECTIONS ADMINISTRATOR has provided costs for election services to be rendered by ELECTIONS ADMINISTRATOR'S office pursuant to the terms of this Contract, which costs are set out in Article VI hereof;

NOW, THEREFORE, the COUNTY, through the ELECTIONS ADMINISTRATOR, and the ENTITY for good and valuable consideration, the adequacy and receipt of which is hereby acknowledged, do hereby agree to hold contract, covenant and agree as follows:

#### ARTICLE I PURPOSE

- 1.01 The parties hereto have entered into this Contract for election services described in Article II to be provided to the ENTITY for its election to be held on **MAY 2, 2026**, and any runoff, if applicable.
- 1.02 If applicable, acknowledgement of Shared Polling Places. The ENTITY acknowledges that the ELECTIONS ADMINISTRATOR, as the County's Contracting Officer in accordance with Section 31.092 of the Texas Election Code, may enter into similar Election Services Contracts with any other entity in the same county that may be running their election concurrently. In such event, the ENTITY agrees to share common polling places with the other entities. It is not the intent of this paragraph to establish a joint election, but rather to share services, equipment, and the costs when it is appropriate, efficient, and economical to do so.

#### ARTICLE II SERVICES

- 2.01 The COUNTY, through the ELECTIONS ADMINISTRATOR, agrees to provide to the ENTITY the following:
  - (A) Procure, provide, code and distribute Hart Hybrid voting systems, election equipment and transport equipment to and from the polling locations, including Early Voting and Election Day, for the ENTITY;
  - (B) Prepare and provide Hart Hybrid training for election workers;

- (C) Prepare and provide Logic and Accuracy testing on ENTITY's election ballot for every Hart Hybrid voting machines to be utilized by ENTITY during Early Voting and Election Day;
- (D) Procure, provide, prepare and code Electronic Poll Book(s) per polling locations with the Voter Registration Database. To include EViD(s), laptop(s), training for poll book, insurance, and delivery fee, as well as supplies such as, but not limited to labels and printer;
- (E) Provide and prepare all mail-in ballot supplies, paper ballots, envelopes and postage;
- (F) Provide training for Election Workers;
- (G) Procure, provide, prepare, and distribute all necessary election supplies, including:
  1. Ballots (print and distribution only);
  2. Election kits and election paperwork;
  3. Voting Equipment;
- (H) Provide cages and covers, cage kit, to include, but not limited to surge protectors, tape, printer, headphones and scanner as well as supplies such as bags, aprons, clipboards, pens, pencils, rulers, magnifiers, inkpads, screen cloths, sanitizers and badges;
- (I) Provide signage to be placed at each polling location regarding Texas Penal Code Section 46.03(a)(2)'s prohibition of firearms on the premises of a polling place;
- (J) Prepare Writ of Election to election officers and notice of appointment to Presiding judges for Election Day, and notify the election judges of the date, time and place of the election as required by law.
- (K) Prepare, distribute, and publish notice of election as required by Texas Election Code Section 4.003(a)(1) and Early Voting and Election Day schedules;
- (L) Notice will also be posted on the Hidalgo County elections website as per Texas Election Code Section 4.008.
- (M) Procure and pay election workers for Early Voting and countywide/districtwide Election Day voting;
- (N) Provide general supervision during the contracted Election period. Advisory services in connection with the decisions to be made and the actions to be taken by the ENTITY may be provided on an as needed basis;
- (O) Procure and pay Early Voting Ballot Board members;
- (P) Provide information for election officers;
- (Q) Provide such incidental related services as may be necessary to conduct the election;
- (R) Serve as the Early Voting Clerk;
- (S) Establish a Central Counting Station for the purpose of tabulating ballots;

- (T) Tabulate election results in preparation for ENTITY's canvassing;
- (U) Preserve locked ballot transport bags containing voted ballots securely in a locked room for 60 days as required by Texas Election Code Section 66.058, at which time, the records will be retained by the Hidalgo County Elections Administrator to serve as custodian for the remainder of the twenty-two month preservation period.
- (V) The ELECTIONS ADMINISTRATOR shall be the agent of the ENTITY for the purposes of contracting with third parties with respect to the election expenses within the scope of the County Elections Administrator's duties;
- (W) The COUNTY shall file copies of this Contract with the County Treasurer and the County Auditor;
- (X) In accordance with Section 31.100(b) of the Texas Election Code, only actual expenses directly attributable to this Contract may be paid. The ELECTIONS ADMINISTRATOR shall submit the actual costs for items contracted pursuant to the Contract with the ENTITY as soon as all invoices from third party vendors are received;
- (Y) If applicable, the COUNTY agrees to provide the election services described herein for a Runoff election.
  - i. The County may combine polling locations in accordance with section 42.0051 of the Election Code, in order to properly supervise and conduct a Runoff election.
  - ii. If a Runoff election is required, the ENTITY hereby agrees to the combining of polling locations, in accordance with section 42.0051 of the Election Code.
  - iii. The COUNTY, through the ELECTIONS ADMINISTRATOR, agrees to provide to the ENTITY the costs for any Runoff Election services to be rendered by the ELECTIONS ADMINISTRATOR'S office pursuant to the terms of this Contract as soon as practicable, once a Runoff is determined necessary.
  - iv. In accordance with Section 31.100(b) of the Texas Election Code, only actual expenses directly attributable to this Contract may be paid. The ELECTIONS ADMINISTRATOR shall submit the actual costs for items contracted pursuant to the Contract with the ENTITY as soon as all invoices from third party vendors are received regarding the Runoff.

2.02 The ENTITY shall be responsible for performing the following:

- (A) Payment of all necessary election supplies as required by the COUNTY, including but not limited to ballots, election kits, mail-in ballot supplies, laptop rentals, labels and combination forms;
- (B) Pay the proportionate cost of election workers for hourly pay submitted by the County Elections Administrator at the rate of \$16.00 per hour for Judges and \$14.00

per hour for Alternate Judges and \$12.00 per hour for Clerks for both Early Voting and Election Day. The entity shall also pay the proportionate cost for training of Election Workers at the rate of \$10.00 per hour per person, and the Delivery / Pick Up Fee of \$50.00 for Election Judges for each Early Voting and Election Day polling location.

- (C) Reimburse the COUNTY for the cost for liability insurance coverage for election workers employed for both Early Voting and Election Day;
- (D) Canvass the Election Results for the ENTITY'S governing body;
- (E) As stated in Section 31.096 of the Texas Election Code, this Contract may not change:
  - (1) the authority with whom applications of candidates for a place on a ballot are filed; and
  - (2) the authority with whom documents are filed under Title 15. Under this Contract, the Hidalgo County Elections Administrator shall be the custodian of voted ballots for 60 days after the date of the election, as required by Texas Election Code 66.058, at which time, the records will be retained by the Hidalgo County Elections Administrator to serve as custodian for the remainder of the twenty two month preservation period.
- (F) Reimburse the COUNTY for any and all costs associated with recounts and/or election contests associated with the election;
- (G) Confirm and/or correct the boundaries of the political subdivision holding the election on a map provided by the County. Once confirmed and/or corrected, Entity certifies the veracity of the boundaries and geographical area that represents the Entity and the area subject to the election.
- (H) If applicable, in consideration for the services provided for a Runoff Election by the COUNTY, the ENTITY agrees to pay ELECTIONS ADMINISTRATOR for the costs of services for a Runoff election.
- (I) Create the appropriate ballot and candidate placement for the Entity's election. Once confirmed and/or corrected Entity shall verify the appropriateness of their ballot under the law.
- (J) Procure Early Voting and Election Day polling locations; Provide contact information on the approval (s) for the use of Early Voting and Election Day polling locations.

### ARTICLE III SCHEDULE FOR PERFORMANCE OF SERVICES

- 3.01 Specific services to be provided related to the general services identified in Article II shall be performed in accordance with the time requirements set out in the Texas Election

Code.

ARTICLE IV  
SERVICES NOT PROVIDED BY COUNTY

- 4.01 ELECTIONS ADMINISTRATOR shall have no responsibility for ensuring the passage of the appropriate Election Order by the ENTITY, publishing and/or posting the Election Order as required by the Texas Election Code section 3.004(3), or Texas Election Code 67.002(2) which is canvassing election results. In addition, ELECTIONS ADMINISTRATOR shall have no responsibility for creating the appropriate ballot and candidate placement for the Entity's election.

ARTICLE V  
TERM

- 5.01 Except as hereinafter set out, the term of this Contract shall be from the time of execution until all items with respect to this Contract and the election held hereunder have been completed.

ARTICLE VI  
COST OF SERVICE AND BILLING

In consideration for the services provided hereunder by ELECTIONS ADMINISTRATOR, the ENTITY agrees to pay ELECTIONS ADMINISTRATOR for the following costs of services:

- 6.01 HART Hybrid:
- (A) One base charge of \$475.00 for Coding Hybrid voting machines, a \$25.00 additional charge per additional ballot styles and a minimum of \$10.00 charge for requested changes on Coded Ballot.
  - (B) A \$10.00 recording fee for each Audio File;
  - (C) Cost of creating election media, such as but limited to V-drives, Verity Keys; etc. at \$100.00 per location.
  - (D) The amount of \$610.00 for each Verity Scan/ Ballot Box, \$150.00 for each Verity Duo Go (curbside) Voting Machine, \$465.00 for each Verity Controller, and a \$447.00 for each Verity Touch Duo Voting Machine;
  - (E) Cost of delivery and pick-up of HART Verity Duo Voting Equipment for Early Voting and Election Day to include fuel charge and mileage at COUNTY's cost;
  - (F) The above described fees shall be additionally charged for any Runoff Election.
- 6.02 Electronic Poll Book:
- (A) Database access at \$100.00 per day;
  - (B) To include but not limited to the Early Voting and Election Day EViD(s) and laptop rentals at \$150.00 per location;
  - (C) Printer label fee of \$.03 per label (price subject to change);
  - (D) Creation of separate Username and password for each polling location at \$20.00 per location;
- 6.03 Fee for Early Voting and Election Day Combination forms, maps, election kits, Verity Access Thermal code paper, and 'I VOTED' stickers, Personal Protective Equipment (PPE). One- hundred sample ballots at no charge with additional

- sample ballots at twenty cents per copy. No charge for provisional ballot bags, table tops if necessary, ballot box (es), custom signs and flags;
- 6.04 Reimbursement of ballot supplies, mail-in ballot kits, paper ballots, correspondence postage, and mail ballot postage (per request) at COUNTY's cost;
- 6.05 Reimbursement fee for publications of all notices and newspaper advertisements, (if applicable)
- 6.07 (A) Cost of election workers for time worked to be submitted to the ENTITY by the ELECTIONS ADMINISTRATOR. The ENTITY shall reimburse the COUNTY for the cost of payroll for election workers at the rate of \$16.00 per hour for Judges and \$14.00 per hour for Alternate Judges and \$12.00 per hour for Clerks for both Early Voting and Election Day. The entity shall also pay the proportionate cost for training of Election Workers at the rate of \$10.00 per hour per person, and the Delivery / Pick Up Fee of \$50.00 for Election Judges for each Early Voting and Election Day polling location.
- (B) Reimburse the County for the cost of payroll overtime incurred by County for regular full time County employees who work during the contracted election (cost to be shared with each contracted entity);
- 6.08 Pay for the cost of the Early Voting Ballot Board judge at the rate of \$16.00 per hour, the Alternate Judge at the rate of \$14.00 per hour, and clerks at the rate of \$12.00 per hour;
- 6.09 Reimbursement to the COUNTY for the cost of liability insurance coverage as set by the County for all election workers employed for the elections;
- 6.10 Reimbursement to the COUNTY for the cost of the use of wireless cell phones at polling locations with the rate set by the wireless vendor at the time of usage which includes an additional per minute fee as charged by the vendor, a service charge of \$10.00 per phone line and a vendor base fee of \$4.99 per phone line;
- 6.11 Billing:
- (A) The form of the invoice to be used in the final billing by the COUNTY, includes a good faith estimate of costs and is attached hereto as Exhibit A.
- (B) After the election and as soon as practicable, upon receiving the final invoice from third party vendors, the County shall prepare and will send to the ENTITY, a final itemized invoice with the actual costs of the Election and will include the 10% Administrative Fee of the actual costs as set forth by Texas Election Code Sec. 31.100(d).
- (C) Full payment shall be made by the ENTITY within thirty (30) days of receipt of the invoice.
- (D) Payment shall be made by check payable to the Hidalgo County Elections
- (E) Notice. Except as may be otherwise specifically provided in this contract, all notices, demands, requests or communication required or permitted hereunder shall be in writing and shall either be (i) personally delivered against a written receipt, or (ii) sent by registered or certified mail, return receipt requested, postage prepaid and addressed to the parties at the addresses set forth below, or at such other addresses as

may have been theretofore specified by written notice delivered in accordance herewith:

Hilda A. Salinas  
Elections Administrator  
Hidalgo County Elections Department  
PO Box 659  
Edinburg, Texas 78540

Dr. Rene Gutierrez  
Superintendent of School  
2200 Tamarack Ave., Portable #691  
McAllen, Texas 78501

- 6.12 Any balances, if any remain after the payment of all costs of election bills, shall be the property of the ENTITY and returned to it.

#### ARTICLE VII

- 7.01 IF ANY OF THE ELECTION EQUIPMENT IS LOST, STOLEN, DESTROYED, OR DAMAGED, THE CITY, SCHOOL DISTRICT OR ENTITY IS LIABLE FOR THE DAMAGE AND AGREES TO PAY THE ELECTIONS ADMINISTRATOR THE COST OF THE REPLACEMENT OR REPAIR OF THE ELECTION EQUIPMENT SO LOST, STOLEN, DESTROYED OR DAMAGED.

#### ARTICLE VIII GENERAL PROVISIONS

- 8.01 This Contract shall be construed under and in accordance with the laws of the State of Texas, and all obligations of the parties created hereunder are performable in Hidalgo County, Texas.
- 8.02 In case any one or more of the provisions contained in this Contract shall for any reason be held to be invalid, illegal or unenforceable in any respect, such invalidity, illegality or unenforceability shall not affect any other provision thereof, and this Contract shall be construed as if such invalid, illegal or unenforceable provision had never been contained herein.
- 8.03 This Contract constitutes the sole and only agreement of the parties hereto and supersedes any prior understanding or written or oral agreement between the parties respecting the written subject matter.
- 8.04 No amendment, modification, or alteration of the term hereof shall be binding unless the same be in writing, dated subsequent to the date hereof and duly executed by the parties hereto

SIGNED this \_\_\_\_\_ day of \_\_\_\_\_, 2026

APPROVAL COUNTY OF HIDALGO

MCALLEN ISD  
ENTITY

BY: \_\_\_\_\_  
RICHARD F. CORTEZ  
COUNTY JUDGE

BY: \_\_\_\_\_  
Dr. Rene Gutierrez,  
Superintendent of School

ATTEST:

ATTEST:

BY: \_\_\_\_\_  
ARTURO GUAJARDO, JR.  
COUNTY CLERK

BY: \_\_\_\_\_

PRINT: \_\_\_\_\_

TITLE: \_\_\_\_\_

ELECTIONS ADMINISTRATOR

MCALLEN INDEPENDENT SCHOOL DISTRICT

BY: \_\_\_\_\_  
HILDA A. SALINAS

By: \_\_\_\_\_

Name: Aaron D Rivera

Title: Board President

Date: \_\_\_\_\_

APPROVED AS TO LEGAL FORM:

Approved as to form

OFFICE OF CRIMINAL DISTRICT ATTORNEY  
Toribio "Terry" Palacios

by:   
JOHNATHAN BALL (Apr 9, 2026 17:32:16 CDT)  
Johnathan Ball, Staff Attorney

BY: \_\_\_\_\_  
Leigh Ann Tognetti,  
Assistant District Attorney



## 2026 Hidalgo County Elections Contract Estimate

EXHIBIT A

PLEASE NOTE THAT THIS TOOL IS FOR ESTIMATION PURPOSES ONLY.  
PRICES ARE SUBJECT TO CHANGE AS DETERMINED BY FINAL INVOICE.

ELECTION: McAllen ISD		DATE: May 2, 2026			
Proposition A					
6.01	<b>Coding Services for HART</b>	<b>Price</b>	<b>Quantity</b>	<b>Total</b>	
A	Base Charge: Ballot Coding	\$475.00	1	\$475.00	
B	Ballot Audio Files	\$10.00	3	\$30.00	
C	Election Media per Polling Location(s)	\$100.00	26	\$2,600.00	
D	Verity Controller(s)	\$465.00	26	\$12,090.00	
D	Verity Touch Duo Machine(s)	\$447.00	52	\$23,244.00	
D	Verity Scan and Ballot Box	\$610.00	26	\$15,860.00	
D	Verity Duo Go Carrier (Curbside Voters)	\$150.00	52	\$7,800.00	
E	Delivery/ Pick-up Fee (includes Mileage)	\$1,800.00	1	\$1,800.00	
<b>Total iVotronic Coding Charges</b>				<b>\$63,899.00</b>	
6.02	<b>Electronic Poll Book</b>	<b>Price</b>	<b>Quantity</b>	<b>Total</b>	
A	Voter Registration Database Access (Per Day)	\$100.00	8	\$800.00	
B	EV/ ED EViD(s)/Laptop Rental	\$150.00	78	\$11,700.00	
C	Printer Labels (per vote)	\$0.03	65293	\$1,958.79	
D	Username/Password - Per Polling Location	\$20.00	2	\$40.00	
<b>Total Electronic Poll Book Charges</b>				<b>\$14,498.79</b>	
6.03	<b>Supplies</b>	<b>Price</b>	<b>Quantity</b>	<b>Total</b>	
	Election Judge Kit for Early Voting	\$50.00	13	\$650.00	
	Election Judge Kit for Election Day	\$50.00	13	\$650.00	
	Verity Access Thermal Code paper (per vote)	\$0.10	65293	\$6,529.30	
	EV/ ED Thermal Ballot paper (per vote)	\$0.40	65293	\$26,117.20	
	I VOTED stickers (per vote)	\$0.01	65293	\$652.93	
	Polling Location Map(s)	\$17.00	26	\$442.00	
	100 Sample ballots provided. Additional Copies of Sample Ballots @ \$0.20 each.	\$0.20	500	\$100.00	
	Covid PPE's per location	\$12.66	26	\$329.16	
<b>Total Supplies Charges</b>				<b>\$35,470.59</b>	
6.04	<b>Mail &amp; Ballot Service</b>	<b>Price</b>	<b>Quantity</b>	<b>Total</b>	
	Mail-in-Paper Ballots	\$0.40	550	\$220.00	
	Mail-in-Ballots Kit(s) per request	\$2.00	550	\$1,100.00	
	Postage Mail-in-Ballots (per request)	\$1.67	550	\$918.50	
	Correspondence Postage	\$0.78	13	\$10.14	
<b>Total Mail &amp; Ballot Service Charges</b>				<b>\$2,248.64</b>	
6.05	<b>Advertisements/Notices</b>	<b>Price</b>	<b>Quantity</b>	<b>Total</b>	
	The Monitor newspaper	\$1,500.00	1	\$1,500.00	
	Local newspaper		0	\$0.00	
<b>Total Advertisement/Notice Charges</b>				<b>\$1,500.00</b>	
6.07	<b>*Payroll for Training and Election Poll Workers</b>	<b>Price</b>	<b>Total</b>		
	Payroll for Early Voting Employees	\$115,232.00	\$115,232.00		
	Payroll for Election Day Employees	\$14,430.00	\$14,430.00		
<b>Total Payroll Charges</b>				<b>\$129,662.00</b>	
		<b>Payroll for Staff Overtime</b>	<b>Price</b>	<b>Total</b>	
		Payroll for Early Voting and Election Day Staff Employees	\$6,000.00	\$6,000.00	
<b>Total Payroll Charges</b>				<b>\$6,000.00</b>	
6.08	<b>Payroll for Ballot Board</b>	<b>Price</b>	<b>Quantity</b>	<b>Total</b>	
	Ballot Board	\$864.00	1	\$864.00	
<b>Total Ballot Board Charges</b>				<b>\$864.00</b>	
6.09	<b>Insurance</b>	<b>Hourly rate</b>	<b>Hours wk</b>	<b>%</b>	<b>Total</b>
	Liability insurance for Early Voting Supervisors ( 13 ) (hourly rate X hrs worked X .0021)	\$ 16.00	1469	0.0021	\$49.36
	Liability insurance for Early Voting Alternates ( 13 ) (hourly rate X hrs worked X .0021)	\$ 14.00	1469	0.0021	\$43.19
	Liability insurance for Early Voting Clerks ( 52 ) (hourly rate X hrs worked X .0021)	\$ 12.00	5876	0.0021	\$148.08
	Liability insurance for Election Day Presiding Judges ( 13 ) (hourly rate X hrs worked X .0021)	\$ 16.00	195	0.0021	\$6.55
	Liability insurance for Election Day Alternates ( 13 ) (hourly rate X hrs worked X .0021)	\$ 14.00	182	0.0021	\$5.35
	Liability insurance for Election Day Clerks ( 52 ) (hourly rate X hrs worked X .0021)	\$ 12.00	676	0.0021	\$17.04
<b>Total Insurance Charges</b>					<b>\$269.57</b>
6.10	<b>Cell Phones</b>	<b>Price</b>	<b>Quantity</b>	<b>Total</b>	
	Verizon Wireless phone (subject to change with out notice)	\$45.00	26	\$1,170.00	
<b>Total Cell Phone Charges</b>				<b>\$1,170.00</b>	
6.11				<b>Subtotal</b>	<b>\$255,582.59</b>
				<b>Administrative Fees (10%)</b>	<b>\$25,558.26</b>
<b>ESTIMATED GRAND TOTAL</b>				<b>\$281,140.85</b>	

**BOARD AGENDA REPORT  
MCALLEN INDEPENDENT SCHOOL DISTRICT**

**MEETING DATE:** April 14, 2026

**SUBJECT:** Report Regarding Nurturing Student Health: McAllen ISD 3-Year Plan

**REFERENCE:** Goal 1: Student Achievement/Student Focus

**BACKGROUND INFORMATION/REASON FOR BOARD CONSIDERATION:**

The Child Nutrition Program is dedicated to providing nutritious, high-quality meals that promote student health and academic success. We are committed to evaluating and improving our meal service by outlining our goals for increasing scratch cooking and presenting our three-year plan focused on enhancing student health.

**ADMINISTRATIVE CONSIDERATIONS/FACTS AND ANALYSIS:**

This item is for information purpose only

**LEGAL REVIEW:**

None

**BUDGETARY CONSIDERATIONS:**

None

**RECOMMENDED BOARD ACTION:**

This item is for information purpose only

**Attachment:**

**SUBMITTED BY:**   
Sonia Esquivel (Apr 2, 2026 07:31:26 CDT)

**SUPERVISOR:**   
Lorena Garcia (Apr 2, 2026 07:59:29 CDT)

For further information contact:  
Name: Sonial Esquivel, Director Child Nutrition Program  
Office: (956) 632-3226  
Email: sonia.esquivel@mcallenisd.net

**Approved for presentation to the Board of Education:**

  
RENE GUTIERREZ (Apr 7, 2026 08:05:01 CDT)



# Nurturing Student Health: McAllen ISD 3-Year Plan

# Federal Programs McAllen ISD Operates

- School Breakfast Program
- National School Lunch Program
- Child & Adult Care Food Program (Supper)
- Fresh Fruit and Vegetable Program
- Seamless Summer Options
- USDA Commodity Foods

# Meals Served



<b>Meal Service</b>	<b>Estimated Daily Meal Served</b>	<b>Estimated Meals in a SY</b>	<b>Summer Meals</b>
Breakfast	12,929	2,417,800	34,507
Lunch	14,362	2,685,719	65,744
Dinner / Snack	2,313	432,520	10,217
Saturday meals		3,038	
<b>Total:</b>	<b>29,604</b>	<b>5,539,077</b>	<b>110,468</b>

## STRETCHING \$4.70 FOR SCHOOL LUNCH

For less than the price of a latte, school meal programs must cover all the costs of preparing a complete, nutritious meal.

IT'S NOT JUST FOOD...



...IT'S SO MUCH MORE...



DELIVERIES

EMPLOYEE  
BENEFITS

PAPERWORK

REPAIRS

SOFTWARE

LABOR

FURNITURE

EQUIPMENT

CUSTODIAL  
SERVICES

UTILITIES

CULINARY  
TRAINING

SUPPLIES

VISIT [SCHOOLNUTRITION.ORG/POSITIONPAPER](https://www.schoolnutrition.org/positionpaper) FOR MORE

99

## School Nutrition Association (SNA) National Survey Results:

- 73% of responding school meals programs are working to offer more local foods with school meals
- 71% reported offering scratch-prepared entrees on at least a weekly basis
- 99% reported needing more funding
  - 79% expressing an “extreme need” for increased funds
- Cited need for more:
  - 94% staff
  - 95% culinary training
  - 94% equipment and infrastructure
  - 96% more time to test recipes

# Chef Ann Foundation & District SCALE Results

The Chef Ann Foundation (CAF) has supported districts in implementing scratch cooking and improving the quality of school meals. They offer a free tool that helps districts assess their current position.

Scratch Cooking Assessment & Learning Evaluation (SCALE) is a tool that provides districts with a tangible, data-driven strategy to enhance our programs and articulate our needs to district counterparts who want to support us in the healthy food effort.

The CAF has grant programs like Get Schools Cooking, where they work with schools for 3 years on a comprehensive support to transition from a heat-and-serve to a scratch cooking operational model



# Chef Ann Foundation & SCALE Results

## 33% Overall Assessment

This assessment reflects the district's overall readiness and infrastructure for supporting scratch cooking and high-quality school meals. It is not a grade or compliance rating; rather, it is a foundational evaluation that identifies strengths and areas for improvement within the nutrition program.



# Chef Ann Foundation 2025 -2026 Baseline Results

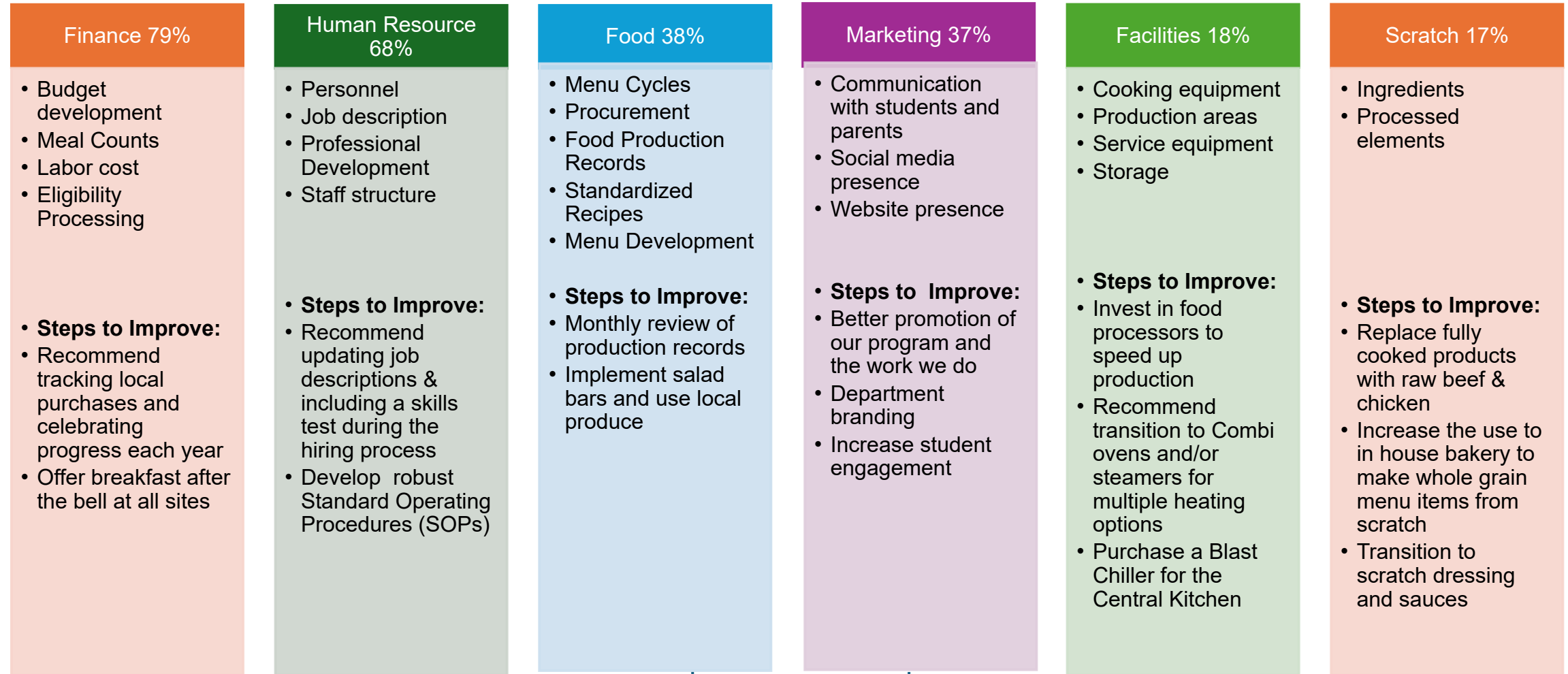

Demonstrates a strong foundation to support change

102  
Systems and engagement need to be strengthened

Shows our greatest area of growth that will require investments and training

# Cafeteria Modernization Overview

---

Total Investment: \$33.05 million through the McAllen ISD Bond Program

Campuses included:

- Milam Elementary
- Alvarez Elementary
- Seguin Elementary
- Morris Middle School





# 3–Year Strategic Plan

# Year 1 Strategic Plan

## 2026 – 2027 SY Menu Life Cycle

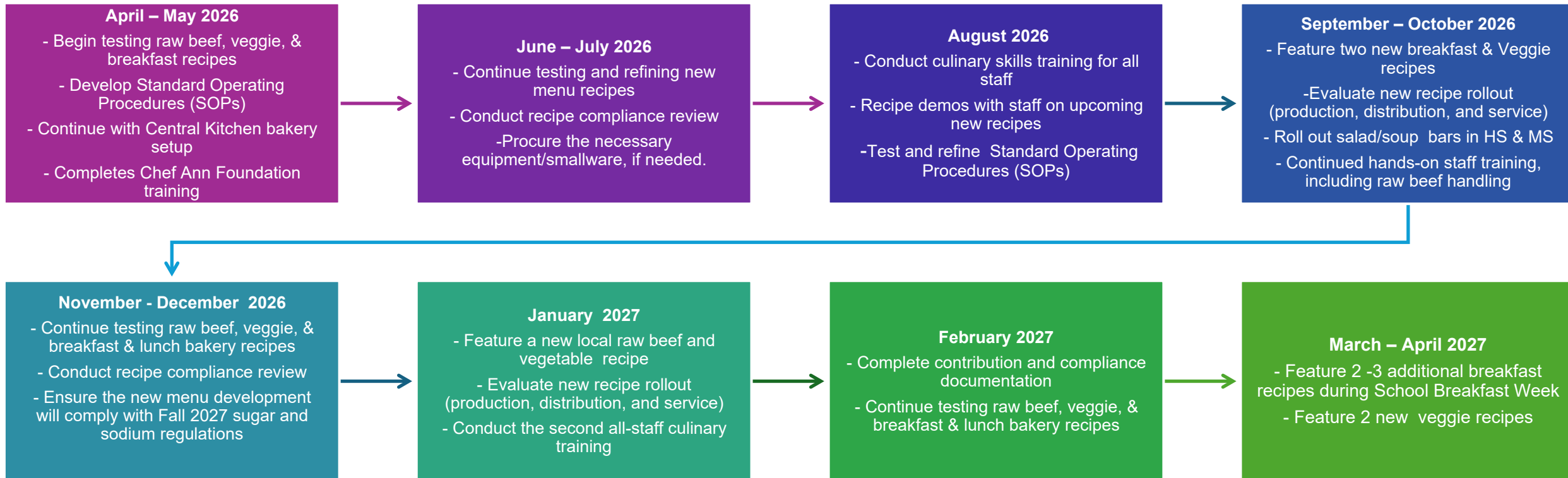

All these changes will increase scratch cooking by 16% throughout the SY

# Breakfast Menu Cycle Update

---

## Current Breakfast Structure:

- We have a 2-week menu cycle for breakfast, with only a few different menu items in weeks 3-4.
- The current menu cycle includes 20 breakfast items, with two daily menu options available to students each day.
- 4 out of the 20 items are scratch-made breakfast tacos, served every Wednesday and Friday.



# 2026 -2027 School Year Breakfast Update

## Revised Breakfast Menu Structure:

- Breakfast menu options will be reduced from 20 to 14 items within a two-week menu cycle.
- Two daily breakfast options will continue to be offered; one option will remain consistent each week, with planned variations
- 7 out of the 14 items will now be scratch-cooked, reflecting a significant increase in freshly prepared options

## Expanded Scratch-Cooked Items Include:

- Breakfast Tacos
- Hot Oatmeal
- Overnight oatmeal
- Yogurt parfaits



# Child Nutrition Program: Year 2 & 3 Strategic Action Plan

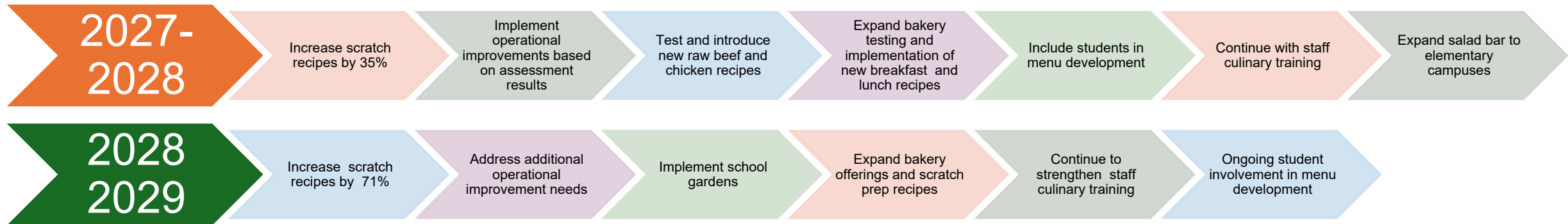

# Farm Fresh Culinary Workshop

- McAllen ISD was proud to be one of seven districts in Texas selected to participate in the inaugural hands-on training, which included live cooking demonstrations and classroom instruction. This week-long training took place from March 9 to March 13, 2026.

- The courses were led by experienced chefs specialized in Child Nutrition. They provided in-depth guidance and helped participants understand how to enhance school meals while ensuring compliance through effective menu development and execution.

- The goal of the training was to return home ready to train our teams and raise the bar for school meals in our district.



A close-up photograph of several triangular slices of watermelon arranged on a light-colored wooden cutting board. The watermelon has a vibrant red, juicy interior and a thin green rind. The slices are slightly overlapping, creating a sense of depth. The background is softly blurred, focusing attention on the fruit.

**We are committed to moving school nutrition  
forward!**

**Thank you!**

**BOARD AGENDA REPORT  
MCALLEN INDEPENDENT SCHOOL DISTRICT**

**MEETING DATE:** April 14, 2026

**SUBJECT:** Report Regarding No. 2022-187 between Texas Association of School Boards Risk Management Fund and McAllen Independent School District

**REFERENCE:** Goal 2: People Development; Strategy 2: Attract/Retain High Quality Staff

**BACKGROUND INFORMATION/REASON FOR BOARD CONSIDERATION:**

The Interlocal Participation Agreement ("IPA") is the foundational agreement of the Texas Association of School Boards Risk Management Fund ("Fund"), it sets out the basic terms, conditions, and requirements of Fund membership. The Fund is a self-funded risk pool, and the IPA is the agreement through which the McAllen Independent School District (the "District") may participate in the various lines of coverage offered by the Fund, including Workers' Compensation, Auto, School Legal Liability, General liability, Property and Unemployment Compensation.

The IPA was previously presented to and approved by the Board on April 11, 2022, and remains in effect indefinitely unless terminated by either party.

**ADMINISTRATIVE CONSIDERATIONS/FACTS AND ANALYSIS:**

In accordance with guidance provided by the TASB Risk Management Fund, administration is providing this agreement to the Board for informational purposes and to reaffirm the awareness of the District's participation.

**LEGAL REVIEW:**

Agreement has been reviewed by legal counsel.

**BUDGETARY CONSIDERATIONS:**

Funds for these purchases are budgeted through the General Fund.

**RECOMMENDED BOARD ACTION:**

This item is presented for informational purposes only.

**SUBMITTED BY:**   
Alberto Canales (Apr 2, 2026 16:37:27 CDT)

**SUPERVISOR:**   
Lorena Garcia (Apr 2, 2026 16:44:17 CDT)

For further information contact:  
Name: Dr. Alberto Canales, Chief Human Resources Officer  
Office: 956-618-6009  
eMail: albert.canales@mcallenisd.net

**Approved for presentation to the Board of Education:**

  
RENE GUTIERREZ (Apr 2, 2026 18:00:48 CDT)

114

**Superintendent of Schools**

## TASB RISK MANAGEMENT FUND INTERLOCAL PARTICIPATION AGREEMENT

Pursuant to the Texas Interlocal Cooperation Act, Chapter 791 of the Texas Government Code, this Interlocal Participation Agreement (Agreement) is entered into by and between the Texas Association of School Boards Risk Management Fund (Fund) and the undersigned local government of the State of Texas (Fund Member). The Fund is an administrative agency of local governments (Fund Members) that cooperate in performing administrative services and governmental functions relative to risk management.

### TERMS AND CONDITIONS

In consideration of the mutual covenants and conditions contained in this Agreement and other good and valuable consideration, including, without limitation, the agreement of the Fund and Fund Members to provide risk management programs as detailed in this Agreement, the receipt and sufficiency of which are hereby acknowledged, Fund Member and the Fund, intending to be legally bound, and subject to the terms, conditions, and provisions of this Agreement, agree as follows:

1. **Authority.** Fund Member hereby approves and adopts the Restatement of Interlocal Agreement, dated May 20, 1997, which restated the Interlocal Agreement dated July 2, 1974, establishing the predecessor of the Fund. The Restatement of Interlocal Agreement is incorporated into this Agreement by reference and is available from the Fund upon request. This Agreement serves to outline the relationship between the Fund and Fund Member. While the Texas Interlocal Cooperation Act provides the overarching basis for the Fund, certain Fund programs are further authorized pursuant to various statutes, such as Chapter 504 of the Texas Labor Code, pertaining to workers' compensation; and Chapter 2259, Subchapter B, of the Texas Government Code, pertaining to other risks or hazards.
2. **Program Participation.** This Agreement enables Fund Member to participate in one or more of the Fund's available programs. Because this is an enabling Agreement, Fund Member must also execute a separate Contribution and Coverage Summary (CCS) for each Fund program from which it seeks coverage and/or administrative services. Only a valid CCS will confer the right to participate in a specific program and each CCS shall be incorporated into this Agreement. Through participation in any Fund program, Fund Member waives none of its immunities and authorizes the Fund, or its designee, to assert such immunities on its behalf and on behalf of the Fund or its designee.
3. **Term of Agreement.** This Agreement shall be effective from the date of the last signature below and shall remain in effect unless terminated as provided in this Agreement. This Agreement will automatically terminate if Fund Member ceases to participate in at least one of the Fund's programs (due to the expiration of a CCS participation term or the valid termination of same) or fails to meet the membership qualifications of the Fund as provided in this Agreement and as determined by the Fund in writing.
4. **Termination.** Unless this Agreement is automatically terminated as described above, this Agreement, and/or any component CCS applicable to Fund Member, can be terminated as set forth below. However, unless specifically required in a CCS, the termination of any single Fund program under a CCS shall not also result in the automatic termination of another pending CCS, or this enabling Agreement if any other CCS is still in force for Fund Member. Rather, each Fund program can only be terminated as provided in this Agreement.
  - a. **By Either Party with 30 Days Notice before Renewal.** Any CCS may be terminated by either party with termination to be effective on any successive renewal date by giving written notice to the other party no later than 30 days prior to automatic renewal.
  - b. **By Fund Member upon Payment of Late Notice Fee.** If Fund Member fails to terminate a CCS as provided above, it may still terminate participation in any Fund program prior to the renewal date by paying a late notice fee as herein provided. If Fund Member terminates the CCS before the renewal date, but with fewer than 30 days' advance written notice, Fund Member agrees to pay the Fund a late notice fee in the amount of 25% of the annual contribution for the expiring participation term. Fund Member expressly acknowledges that the late notice fee is not a penalty, but a reasonable approximation of the Fund's damages for the Fund Member's untimely withdrawal from the program identified in the CCS. However, once the renewal term of a CCS commences, Fund Member can no longer terminate the CCS by paying a late notice fee; the CCS shall renew and Fund Member must pay 100% of the annual contribution for the renewal period.
  - c. **By the Fund upon Breach by Fund Member.** The Fund may terminate this Agreement or any CCS based on breach of any of the following obligations, by giving 10 days' written notice to Fund Member of the breach; and Fund Member's failure to cure the breach within said 10 days (or other time period allowed by the Fund):
    - 1) Fund Member fails or refuses to make the payments or contributions required by this Agreement;
    - 2) Fund Member fails to cooperate and comply with any reasonable requests for information and/or records made by the Fund;

- 3) Fund Member fails or refuses to follow loss prevention or statutory compliance requirements of the Fund, as provided in this Agreement; or
- 4) Fund Member otherwise breaches this Agreement.

If the Fund terminates this Agreement, or any CCS, based on breach as described above, Fund Member agrees that the Fund will have no responsibility of any kind or nature to provide coverage on the terminated Fund program post-termination. Further, Fund Member shall bear the full financial responsibility for any unpaid open claim and expense related to any claim, asserted or unasserted and reported or unreported, against the Fund or Fund Member, or incurred by the agents or representatives of Fund Member.

In addition to the foregoing, if termination is due to Fund Member's failure to make required payments or contributions, Fund Member agrees that it shall pay the Fund liquidated damages in the amount of 50% of the annual contribution for the participation term identified in the terminated CCS.

## 5. Contributions.

- a. **Agreement to Pay Contribution.** Fund Member agrees to pay its contribution for each Fund program in which it participates based on a plan developed by the Fund. The amount of contribution will be stated in the relevant CCS and will be payable upon receipt of an invoice from the Fund. Late fees amounting to the maximum interest allowed by law, but not less than the rate of interest authorized under Chapter 2251, Texas Government Code, shall begin to accrue daily on the first day following the due date and continue until the contribution and late fees are paid in full. If Fund Member fails to pay the amounts due under this Agreement, including any CCS, the Fund may redirect other amounts due to the Fund Member, payments received from Fund Member, or amounts held by the Fund for Fund Member's benefit, to offset the amount owed. Any offset will not extinguish Fund Member's obligation for any and all payments due under this Agreement, including any CCS.
- b. **Other Payments Due to the Fund.** In addition to contributions, if the Fund Member owes other payments to the Fund, such as deductibles or claim overpayments, and Fund Member fails to timely pay the amounts due, the Fund may redirect other amounts due to the Fund Member, payments received from Fund Member, or amounts held by the Fund for the Fund Member's benefit to offset the amounts owed.
- c. **Estimated Contribution and Contribution Adjustment.** In specified situations, the amount of contribution shown in the CCS will be identified as an estimate. The Fund reserves the right to request an audit of updated exposure information at the end of the CCS participation term and adjust contributions if Fund Member's exposure changes during the CCS participation term. As a result of the exposure review, any additional contribution payable to the Fund shall be paid by Fund Member, and any overpayment of contribution by Fund Member shall be returned or credited by the Fund. The Fund reserves the right to audit the relevant records of Fund Member in order to conduct this exposure review.

Upon expiration of each participation period, Fund Member may request a contribution adjustment due to exposure changes. Such request must be made in writing within 60 days after the end of the participation period. Fund Member must provide documentation as requested by the Fund to demonstrate that the exposure change warrants a contribution adjustment.

The annual contribution may be adjusted due to an exposure change or audit as presented in the CCS. The Fund may also request a contribution adjustment should the Fund's underwriting income for any program within a given program year be inadequate to pay the ultimate cost of claims incurred for that year, the Fund may collect an adjusted contribution from any current or former Fund Member if that Fund Member's contribution is inadequate to pay the Fund Member's claims incurred during that year.

6. **Contribution and Coverage Summary.** Fund Member agrees to abide by each CCS that governs its participation. A CCS will incorporate the program specific coverage document, if any, which sets forth the scope of coverage and/or services from the Fund. This Agreement will be construed to incorporate the CCS, Coverage Agreements, Endorsements, and Addenda, if any, whether or not physically attached. A CCS for a Fund program will state the participation term. After Fund Member's execution of a CCS, the CCS will automatically renew annually, unless terminated in accordance with this Agreement. Any renewal containing a change in the amount of contribution or other terms will be subject to the Amendment by Notice process described in this Agreement.
7. **Loss Prevention.** The Fund may provide loss prevention services to Fund Member. Fund Member agrees to adopt the Fund's reasonable and customary standards for loss prevention and to cooperate in implementing any and all reasonable loss prevention and statutory compliance recommendations or requirements. The Fund makes no warranty on Fund loss prevention recommendations.

## 8. Other Duties of Fund Member.

- a. **Standards of Performance.** Time shall be of the essence in Fund Member's reporting of any and all claims to the Fund, payment of any contributions or monies due to the Fund, and delivery of any written notices under this Agreement.
- b. **Claims Reporting.** Notice of any claim must be provided to the Fund as required by law or the applicable Coverage Agreement. Failure by Fund Member to timely report a claim may result in denial of coverage or payment of fines or penalties imposed by law or regulatory agencies. If the Fund advances payment of any fine or penalty arising from Fund Member's late claim reporting, Fund Member will reimburse the Fund for all such costs.
- c. **Cooperation and Access.** Fund Member agrees to cooperate and to comply in a timely manner with all reasonable requests for access, information and/or records made by the Fund or by a third-party acting for the Fund. Fund Member further agrees to provide complete and accurate statements of material facts, to not misrepresent or omit such facts, or make false statements to the Fund. The Fund Member agrees that any information held by the Fund's Administrator, or its' affiliated entities may be provided to the Fund. The Fund reserves the right to audit the relevant records of Fund Member to determine compliance with this Agreement.

9. **Administration of Claims.** The Fund or its designee agrees to administer all claims for which Fund Member has coverage after Fund Member provides timely written notice to the Fund. Fund Member hereby authorizes the Fund or its designee to act in all matters pertaining to handling of claims for which Fund Member has coverage pursuant to this Agreement. Fund Member expressly agrees that the Fund has sole authority in all matters pertaining to the administration of claims and grants the Fund or its designee full decision-making authority in all matters, including without limitation, discussions with claimants and their attorneys or other duly authorized representatives. Fund Member further agrees to be fully cooperative in supplying any information reasonably requested by the Fund in the handling of claims. All decisions on individual claims shall be made by the Fund or its designee, including, without limitation, decisions concerning claim values, payment due on the claim, settlement, subrogation, litigation, or appeals.

10. **Excess Coverage/Reinsurance.** The Fund, in its sole discretion, may purchase excess coverage or reinsurance for any or all Fund programs. In the event of a substantial change in terms or cost of such coverage, the Fund reserves the right to make adjustments to the terms and conditions of a CCS as allowed by the Amendment by Notice process under this Agreement. If any reinsurer, stop loss carrier, and/or excess coverage provider fails to meet its obligations to the Fund or any Fund Member, the Fund is not responsible for any payment or any obligations to Fund Member from any reinsurer, stop loss carrier, or excess coverage provider.

## 11. Subrogation and Assignment of Rights.

- a. Fund Member, on its own behalf and on behalf of any person entitled to benefits under this Agreement, assigns all subrogation rights to the Fund. The Fund has the right, in its sole discretion, without notice to Fund Member, to bring all claims and lawsuits in the name of Fund Member or the Fund. Fund Member agrees that all subrogation rights and recoveries belong first to the Fund, up to the amount of benefits, expenses, and attorneys' fees incurred by the Fund, with the balance, if any, being paid to Fund Member, unless otherwise specifically stated in the Agreement. Award of funds to any person entitled to coverage, whether by judgment or settlement, shall be conclusive proof that the injured party has been made whole. Fund Member's right to be made whole is expressly superseded by the Fund's subrogation rights. If Fund Member procures alternate coverage for a risk covered by the Fund, the latter acquired coverage shall be deemed primary coverage concerning that risk.
- b. Fund Member shall do nothing to prejudice or waive the Fund's existing or prospective subrogation rights under this Agreement. If Fund Member has waived any subrogation right without first obtaining the Fund's written approval, the Fund shall be entitled to recover from Fund Member any sums that it would have been able to recover absent such waiver. Recoverable amounts include attorneys' fees, costs, and expenses.

12. **Appeals.** Fund Member shall have the right to appeal any written decision or recommendation to the Fund's Board of Trustees, and the Board's determination will be final. Any appeal shall be made in writing to the Board Chair within 30 days of the decision or recommendation.

13. **Bylaws, Policies, and Procedures.** Fund Member agrees to abide by the Bylaws of the Fund, as they may be amended from time to time, and any and all written policies and procedures established by the Fund (which are available from the Fund upon written request). If a change is made to the Fund's Bylaws, written policies or procedures which conflicts with or impairs a CCS, such change will not apply to Fund Member until the renewal of such CCS, unless Fund Member specifically agrees otherwise.

14. **Payments.** Fund Member represents and warrants that all payments required under this Agreement of Fund Member shall be made from its available current revenues.

15. **Fund Member's Designation of Coordinator.** Fund Member agrees to designate an employee with appropriate authority as coordinator (Program Coordinator) for Fund Member on this Agreement or any CCS executed by Fund Member. Fund Member's Program Coordinator shall have express authority to represent and to bind Fund Member, shall fully communicate with the Fund regarding Fund business, and shall not delegate this communication to a third party. The Fund will not be required to contact any other individual regarding matters arising from or related to this Agreement. Fund Member reserves the right to change its Program Coordinator as needed, by giving written notice to the Fund; such notice is not effective until actually received by the Fund. Notice provided to the Chief Executive Officer of Fund Member shall also serve as notice to the Program Coordinator.
16. **Risk Sharing Agreement.** This Agreement is a risk sharing and risk participation agreement and should not be construed to be a contract of insurance. If any ambiguity exists in this Agreement, including any CCS or specific coverage document, the provision shall not be construed against the Fund as drafter of this Agreement. The Fund is not an insurance company nor is any member an insured. The Fund is a self-insured risk pool through which its members agree to share risk and actively participate in their contractual obligations to lessen risk and cost for all members. Any reference in this Agreement to an insurance term or concept is coincidental, is not intended to characterize the Fund as "insurance" as defined by law, shall be deemed to apply to self-insurance, and is not to be construed as being contrary to the self-insurance concept.
17. **Representation.** Fund Member authorizes the Fund to represent Fund Member in any lawsuit, dispute, or proceeding arising under or relating to any Fund program and/or coverage in which Fund Member participates. The Fund may exercise this right in its sole discretion and to the fullest extent permitted or authorized by law. Fund Member shall fully cooperate with the Fund, its designee, and the Fund's chosen counsel, including, without limitation, supplying any information necessary or relevant to the lawsuit, dispute, or proceeding in a timely fashion. Subject to specific revocation, Fund Member designates the Fund to act as a class representative on its behalf in matters arising out of this Agreement.
18. **Members' Equity.** The Fund Board, in its sole discretion, may declare a distribution of the Fund's members' equity to Fund Members. Members' equity belongs to the Fund. No current or former individual Fund Member is entitled to an individual allocation or portion of members' equity.
19. **Entire Agreement.** This Agreement, together with the Restated Interlocal Agreement, Bylaws, CCSs, and Coverage Agreements that are in effect as to Fund Member from time to time, represent and contain the complete understanding and agreement of the Fund and Fund Member, and there are no representations, agreements, arrangements, or undertakings, oral or written, between the Fund and Fund Member other than those set forth in this Agreement duly executed in writing. In the event of conflict between the terms of this Agreement and the Restated Interlocal Agreement, Bylaws, CCS, or any Coverage Agreement, the specific terms of the later adopted agreement shall prevail to the extent necessary to resolve the conflict. This Agreement replaces all previous Interlocal Participation Agreements between the Fund and Fund Member. Notwithstanding the foregoing, this Agreement does not supersede any unexpired participation term or pending claim under an existing agreement between Fund Member and Fund.
20. **Amendment by Notice.** This Agreement, including any of its component CCSs or coverage documents, may be amended by the Fund, in writing, by providing Fund Member with written notice before the earlier of (i) the effective date of the amendment or (ii) the date by which Fund Member can terminate without payment of late notice fees or liquidated damages. Unless this Agreement expressly provides otherwise, an amendment shall only apply prospectively and Fund Member shall have the right to terminate this Agreement, or a component CCS to which the amendment applies, before the amendment becomes effective, as provided in this Agreement. If Fund Member fails to give the Fund timely written notice of termination, Fund Member shall be deemed to have consented to the Fund's amendment and agrees to abide by and be bound by the amendment, without necessity of obtaining Fund Member's signature.

The Fund may amend this Agreement or any CCS effective upon renewal. Amendments may be for any reason including changes to the terms or contribution amount.

The Fund may also amend this Agreement or any CCS, effective during the term of a CCS, for any reason including but not limited to the following:

- a. State or federal governments, including any court, regulatory body, or agency thereof, adopt a statute, rule, decision, or take any action that would substantially impact the rights or financial obligations of the Fund as it pertains to this Agreement, or any Fund program or CCS.
- b. The terms of the Fund's stop-loss or excess coverage or reinsurance change substantially.

If the Fund exercises the option to amend the Agreement or any CCS during the term of a CCS and prior to renewal, the Fund shall give Fund Member 30 days advance written notice. Fund Member will then have the right during the 30-day period to give the Fund written notice of termination of the applicable Fund program, effective upon the expiration of the 30-day notice period (or longer period if so provided by the Fund in writing).

21. **Severability; Interpretation.** If any portion of this Agreement shall be declared illegal or held unenforceable for any reason, the remaining portions shall continue in full force and effect. Any questions of particular interpretation shall not be interpreted against the drafter of this Agreement, but rather in accordance with the fair meaning thereof.
22. **Dispute Resolution.** This Agreement shall be governed by and construed in accordance with the laws of the State of Texas, without regard to conflict of law principles that would require the application of the laws of another state. The Fund retains its governmental immunity except to the extent it is waived by the legislature. The parties agree that the following adjudication procedures apply to any legal dispute, and that the Fund Member's right to file suit against the Fund is contingent upon compliance with these procedures pursuant to Texas Local Government Code section 271.154:
- Prior to filing suit, the Fund Member must comply with all of its obligations under this Agreement and any specific Coverage Agreement including an appeal to the Fund Board as described by Section 12 of this Agreement. A good-faith appeal to the Fund Board is a pre-suit adjudication procedure that is required before litigation by a Fund Member against the Fund.
  - Prior to filing suit, the Fund Member will participate in good faith in mediation in Travis County, Texas before a mediator approved by both parties; and
  - Any suit against the Fund must be brought in Travis County, Texas.

In the event of a lawsuit or formal adjudication between Fund Member and the Fund, the prevailing party is entitled to recover reasonable and necessary attorneys' fees and expenses, including expert fees, that are equitable and just.

**Waiver and Estoppel.** No provision of this Agreement will be deemed waived by either party unless expressly waived in writing by the waiving party. No waiver shall be implied by delay or any other act or omission. No waiver by either party of any provision of this Agreement shall be deemed a waiver of such provision with respect to any subsequent matter relating to such provision. Estoppel may not be asserted against either party so as to prevent that party from enforcing or insisting on the other party's compliance with any provision of this Agreement.

**Assignment.** This Agreement or any duties or obligations imposed by this Agreement shall not be assignable by Fund Member without the prior written consent of the Fund. Fund Member shall not transfer any interest in Fund claim related payments to any third party, including, but not limited to litigation finance companies, attorneys, banks, public adjusters, architects, engineers, or contractors. Any action by the Fund Member which grants or attempts to grant to any third party an interest in or control over any claim payment, including, but not limited to, the Member's entry into a contingent fee contract, will immediately suspend any obligation by the Fund to make any claim payment under this Agreement. The obligation of the Fund to make any such claim payments shall not be restored unless and until the Fund Member provides the Fund with evidence reasonably satisfactory to the Fund that any such transfer or attempt to transfer an interest in or control over such claim payment to a third party has effectively been terminated.

23. **Authorization.** By the execution of this Agreement, the undersigned individuals warrant that they have been authorized by all requisite governance action to enter into and to perform the terms and conditions of this Agreement and that the Fund Member authorizes the Program Coordinator or Chief Executive Officer to approve and bind the Fund Member to any current or future CCS entered into under this Agreement
24. **Notice.** Unless expressly stated otherwise in this Agreement, any notice required or provided under this Agreement by either party to the other party shall be in writing and shall be sent by first class mail, postage prepaid or by a carrier for overnight service or by electronic means typically used in commerce. Notice to the Fund shall be sufficient if made or addressed as follows: TASB Risk Management Fund, P.O. Box 301, Austin, Texas 78767-0301, or [tasbrmf@tasbrmf.org](mailto:tasbrmf@tasbrmf.org). The Fund's required notice address may be updated through explicit written or electronic notice to Fund Members. Notice to a Fund Member shall be sufficient if addressed to the Program Coordinator or Fund Member's Chief Executive Officer and mailed to Fund Member's physical or electronic address of record on file with the Fund.
25. **Miscellaneous.** These provisions apply throughout this Agreement:
- Fund reference.** Any reference to the Fund in this Agreement includes reference to its designees.
  - CCS reference.** References to a Contribution and Coverage Summary (CCS) includes a reference to all separate coverage portions of a CCS and/or any similar service agreement between the Fund and a Fund Member.
  - "Including."** Unless the context requires otherwise, the term "including" means "including but not limited to."
  - Successors.** This Agreement binds and inures to the benefit of the parties and their successors.
  - Headings.** The headings are for convenience only and do not affect the interpretation of this Agreement.

26. **Signatures/Counterparts.** The failure of a party to provide an original, manually executed signature to the other party shall not affect the validity or enforceability of this Agreement. Either party may rely upon a facsimile or imaged signature as if it were an original. This Agreement may be executed in several separate counterparts, each of which shall be an original and all of which shall constitute one and the same instrument.

WHEREFORE, the parties agree to be bound by this Agreement by signing below.

For FUND MEMBER: **McAllen ISD**

By: Sam Saldivar, Jr.  
Sam Saldivar, Jr. (Apr 12, 2022 20:05 CDT)

Signature of Fund Member's Authorized Representative

Printed Name of Fund Member's Authorized Representative

Sam Saldivar, Jr., President, Board Of Trustees

Date: Apr 12, 2022

Approved as to form:  
Atlas, Hall & Rodriguez LLP

By: Stephen L. Crain  
Stephen L. Crain (Apr 12, 2022 11:28 CDT)  
Stephen L. Crain

Date approved by Fund Member's Board of Trustees: 04/11/2022

**For TASB Risk Management Fund Use Only**

**For TASB RISK MANAGEMENT FUND:**

By: \_\_\_\_\_

Date: \_\_\_\_\_

Chair, TASB Risk Management Fund Board of Trustees

**BOARD AGENDA REPORT  
McALLEN INDEPENDENT SCHOOL DISTRICT**

April 14, 2026

**MEETING DATE:** \_\_\_\_\_

SUBJECT: Discussion and Possible Action of the McAllen Independent School District March Budget Amendment for Fiscal Year Beginning July 1, 2025 and Ending June 30, 2026.

REFERENCE: Goal 4, Strategy 7 - Financial Priorities

BACKGROUND INFORMATION/REASON FOR BOARD CONSIDERATION:

In accordance with TEA budget and accounting procedures guidelines, the District's official budget is comprised of the General Fund which includes Food Service and the Debt Service Fund. The District has administratively opted to officially adopt the Capital Projects Fund budget. The adoption of the budgets associated with these funds, and subsequent amendments, should be approved by the Board of Trustees. The authority to approve a budget or a budget amendment for a grant program, however, lies with the granting agency and not with the District's Board.

The administration will routinely allow amendments of existing budgeted funds between major function levels, in order to accommodate the necessary operations of the requesting department or campus. These amendments usually become necessary due to account coding requirements. These requests allowed at the administrative level are subject to final approval by the Board of Trustees.

The budget amendments are broken down into the following two categories:

1. Revisions – amendments that are necessary because of policy changes or revisions to programs that increase/decrease the budget.
2. Transfers – amendments that are necessary and/or amounts require adjustments but do not increase/decrease the budget.

ADMINISTRATIVE CONSIDERATIONS/FACTS AND ANALYSIS:

The budget amendment detail provides explanations for the revisions and transfers.

LEGAL REVIEW:

None required.

BUDGETARY CONSIDERATIONS:

	General Fund
Audited Fund Balance	\$ 152,193,437
Revenues	273,023,944
Expenditures	286,987,262
Preliminary Ending Fund Balance	\$ 138,230,119

**BOARD AGENDA REPORT  
McALLEN INDEPENDENT SCHOOL DISTRICT**

**MEETING DATE:** April 14, 2026

**SUBJECT:** Discussion and Possible Action of the McAllen Independent School District March Budget Amendment for Fiscal Year Beginning July 1, 2025 and Ending June 30, 2026.

**REFERENCE:** Goal 4, Strategy 7 - Financial Priorities

**RECOMMENDED BOARD ACTION:**

That the Board of Trustees approve the McAllen Independent School District March Budget Amendment for the General Fund for Fiscal Year Beginning July 1, 2025 and Ending June 30, 2026.

Attachment:

**SUBMITTED BY:** JOEL GARCIA  
JOEL GARCIA (Apr 2, 2026 13:31:08 CDT)

**SUPERVISOR:** Lorena Garcia  
Lorena Garcia (Apr 2, 2026 13:52:36 CDT)

For further information contact:  
Name: Joel Garcia, CPM, RTSBA  
Office: (956) 618-6016  
eMail: joel.garcia@mcallenisd.net

Approved for presentation to the Board of Education:

RENE GUTIERREZ  
RENE GUTIERREZ (Apr 2, 2026 14:18:45 CDT)

Superintendent of Schools

**GENERAL FUND  
REVISIONS**

**MARCH 2026 BUDGET AMENDMENT**

***REVENUES***

**Local**

Student Contribution for Study Abroad Salamanca Spain Trip for Fund 199 General Fund	47,600	
		\$ 47,600

**State**

Increase to TRS On-Behalf for Contributions Made by the State of Texas on Behalf of School District Employees:		
- Fund 155 College, Career and Military Readiness	1,957	
- Fund 156 Early Education Allotment	2,317	
- Fund 157 Dyslexia	29,730	
- Fund 164 Bilingual	9,100	
- Fund 173 Special Education	114,700	
- Fund 193 Compensatory Education	63,650	
- Fund 199 General Fund	10,100	
Increase to Teacher Incentive Allotment for Fund 199 General Fund	3,430,013	
Increase in Designation Fee Reimbursement for Teacher Incentive Allotment for Fund 199 General Fund	203,000	
		\$ 3,864,567

**Other Sources**

Transfer to Fund 199 General Fund From Fund 713 Safe and Secure – To Purchase Snacks for STAAR Testing Students at Perez Elementary	500	
Transfer to Fund 199 General Fund From Fund 713 Safe and Secure – To Purchase and Install Playscape at Perez Elementary	49,882	
Increase to Proceeds from Right to Use Leased Assets for TEQ Inc. Lenovo Laptop Lease for Fund 199 General Fund	1,864,806	
		\$ 1,915,188

**Total Revenues**     \$ 5,827,355

**GENERAL FUND  
REVISIONS**

***EXPENDITURES***

**Function 11**

Transfer From Fund 199 General Fund, Fund Balance – To Provide Funding for Summer Acceleration Courses Extra Duty Pay	27,898	
Increase to TRS On-Behalf for Contributions Made by the State of Texas on Behalf of School District Employees:		
- Fund 155 College, Career and Military Readiness	1,685	
- Fund 157 Dyslexia	16,508	
- Fund 164 Bilingual	5,850	
- Fund 173 Special Education	56,800	
- Fund 193 Compensatory Education	43,050	
- Fund 199 General Fund	2,500	
Increase to Fund 199 General Fund for Teacher Incentive Allotment Payments to Eligible Educators	3,350,509	
Increase to Fund 199 General Fund to Purchase Eduphoria Software Licenses for Teacher Incentive Allotment	102,060	
Increase to Fund 199 General Fund for Miscellaneous Operating Costs, Supplies, and Program Support Reserve for Teacher Incentive Allotment	128,840	
Increase to Fund 199 General Fund for TEQ Inc. Lenovo Laptop Lease	1,864,806	
Increase to Student Travel for Study Abroad Salamanca Spain Trip for Fund 199 General Fund	47,600	
Increase to Fund 199 General Fund to Purchase Snacks for STAAR Testing Students at Perez Elementary	500	
		\$ 5,648,606

**Function 12**

Increase to TRS On-Behalf for Contributions Made by the State of Texas on Behalf of School District Employees:		
- Fund 193 Compensatory Education	3,000	
		\$ 3,000

**Function 13**

Increase to TRS On-Behalf for Contributions Made by the State of Texas on Behalf of School District Employees:		
- Fund 155 College, Career and Military Readiness	272	
- Fund 156 Early Education Allotment	2,317	
- Fund 157 Dyslexia	446	
- Fund 164 Bilingual	1,250	
- Fund 173 Special Education	100	
- Fund 193 Compensatory Education	1,100	
Increase to Fund 199 General Fund for Training, Travel, and Contract Expenses for Teacher Incentive Allotment	51,604	
		\$ 57,089

**GENERAL FUND  
REVISIONS**

**Function 21**

Increase to TRS On-Behalf for Contributions Made by the State of Texas on Behalf of School District Employees:		
- Fund 164 Bilingual	2,000	
- Fund 173 Special Education	8,500	
- Fund 193 Compensatory Education	4,000	
		\$ 14,500

**Function 23**

Increase to TRS On-Behalf for Contributions Made by the State of Texas on Behalf of School District Employees:		
- Fund 193 Compensatory Education	1,750	
- Fund 199 General Fund	1,600	
		\$ 3,350

**Function 31**

Increase to TRS On-Behalf for Contributions Made by the State of Texas on Behalf of School District Employees:		
- Fund 157 Dyslexia	12,776	
- Fund 173 Special Education	16,800	
- Fund 193 Compensatory Education	6,250	
- Fund 199 General Fund	6,000	
		\$ 41,826

**Function 32**

Increase to TRS On-Behalf for Contributions Made by the State of Texas on Behalf of School District Employees:		
- Fund 173 Special Education	2,000	
- Fund 193 Compensatory Education	4,300	
		\$ 6,300

**Function 34**

Increase to TRS On-Behalf for Contributions Made by the State of Texas on Behalf of School District Employees:		
- Fund 173 Special Education	30,000	
		\$ 30,000

**Function 36**

Increase to TRS On-Behalf for Contributions Made by the State of Texas on Behalf of School District Employees:		
- Fund 173 Special Education	500	
		\$ 500

**Function 51**

Increase to Fund 199 General Fund to Purchase and Install Playscape at Perez Elementary	49,882	
		\$ 49,882

**Function 61**

Increase to TRS On-Behalf for Contributions Made by the State of Texas on Behalf of School District Employees:		
- Fund 193 Compensatory Education	200	
		\$ 200

122

<b>Total Expenditures</b>	<b>\$ 5,855,253</b>
<b>Grand Total</b>	<b>\$ (27,898)</b>

Description	A	B	C		D	E
	Original Budget	Revised Budget 02/28/2026	Budget Amendments Under Consideration		Revised Budget 03/31/2026	
			Revisions	Transfers		
<b>Audited Fund Balance</b>	<b>152,193,437</b>	<b>152,193,437</b>				<b>152,193,437</b>
Revenues:						
Local:						
Property Taxes	68,519,390	68,519,390				68,519,390
Interest Income	5,060,000	5,060,000				5,060,000
Other Local Income	2,309,339	2,366,290	47,600			2,413,890
State:	162,342,929	164,433,452	3,864,567			168,298,019
Federal:	26,739,389	26,786,195				26,786,195
Other Sources:	0	31,262	1,915,188			1,946,450
<b>Total Revenues</b>	<b>264,971,047</b>	<b>267,196,589</b>	<b>5,827,355</b>	<b>0</b>		<b>273,023,944</b>
Expenditures:						
11 Instruction	138,697,011	142,408,051	5,648,606	(129,279)		147,927,378
12 Inst. Res. & Media Services	3,388,065	3,407,296	3,000	(4,401)		3,405,895
13 Curriculum Dev. & Inst. Staff Dev.	4,025,308	4,332,922	57,089	19,782		4,409,793
21 Inst. Leadership	2,882,352	3,220,560	14,500	36,252		3,271,312
23 School Leadership	14,430,235	14,713,863	3,350	27,784		14,744,997
31 Guid., Counseling & Eval. Ser.	11,873,258	11,791,672	41,826	67,334		11,900,832
32 Social Work Services	1,937,220	2,007,325	6,300	(799)		2,012,826
33 Health Services	3,015,984	3,042,947		(744)		3,042,203
34 Student (Pupil) Trans.	4,636,380	5,564,344	30,000	7,012		5,601,356
35 Food Services	24,301,030	24,535,577				24,535,577
36 Curricular/Extracurricular Act.	10,419,966	12,330,749	500	32,543		12,363,792
41 General Administration	7,892,182	8,262,743				8,262,743
51 Plant Maint. & Operations	21,305,420	23,192,483	49,882	(32,260)		23,210,105
52 Security and Monitoring Serv.	5,411,206	6,428,161		12,479		6,440,640
53 Data Processing Services	5,372,159	5,580,868		(37,303)		5,543,565
61 Community Services	92,015	96,218	200	(400)		96,018
71 Debt Service	4,485,637	5,389,187		2,000		5,391,187
81 Fac. Acquisition & Const.	5,000	3,432,096				3,432,096
95 Pmt. to Juv. Justice Alt. Ed. Prg.	40,000	40,000				40,000
99 Other Intergovernmental Charges	1,354,947	1,354,947				1,354,947
Other Uses	0	0				0
<b>Total Expenditures</b>	<b>265,565,375</b>	<b>281,132,109</b>	<b>5,855,253</b>	<b>0</b>		<b>286,987,262</b>
<b>Preliminary Ending Fund Balance</b>	<b>151,599,109</b>	<b>138,258,017</b>	<b>(27,898)</b>	<b>0</b>		<b>138,230,119</b>

**BOARD AGENDA REPORT  
MCALLEN INDEPENDENT SCHOOL DISTRICT**

**MEETING DATE:** April 14, 2026

**SUBJECT:** Discussion and Possible Action to Approve Board of Education Meeting Minutes

**REFERENCE:** N/A

**BACKGROUND INFORMATION/REASON FOR BOARD CONSIDERATION:**

The minutes for each meeting of the Board of Education are traditionally brought to the Board for approval. After approved, the minutes become the official Record for Board Action.

**ADMINISTRATIVE CONSIDERATIONS/FACTS AND ANALYSIS:**

The meeting minutes have been prepared and reviewed for accuracy. Approval of these minutes ensures proper documentation of Board proceedings and compliance with record-keeping requirements.

**LEGAL REVIEW:**

No legal issues are anticipated with the approval of meeting minutes. This item is presented as a standard governance practice.

**BUDGETARY CONSIDERATIONS:**

There are no budgetary considerations associated with this item.

**RECOMMENDED BOARD ACTION:**

That the Board of Trustees approve the Board of Education meeting minutes as presented for the following:

Board Workshop -February 26, 2026 (Strategic Planning)

Regular Board Meeting - March 9, 2026

Board Workshop - March 11, 2026 (Purchasing Scoring Matrix)

Board Workshop - March 23, 2026 (Budget #3)

Board Workshop - March 24, 2026 (Student Recognition)

**Attachment:**

**SUBMITTED BY:** 

**SUPERVISOR:** 

For further information contact:

Name: Norma Ramirez

Office: (956) 688-5418

Email: norma.ramirez@mcallsisd.net

**Approved for presentation to the Board of Education:**

  
RENE GUTIERREZ (Apr 1, 2026 15:28:31 CDT)



## Board Workshop

Thursday, February 26, 2026 3:00 PM

Board Room/Administration Building of the McAllen Independent School District, 2000 North 23rd Street, McAllen, TX 78501

Attendance Taken at 3:00 PM.

Robert Carreon:	Present
Erica de la Garza-Lopez:	Present
Roberto Haddad:	Present
Lizzie Kittleman:	Present
Sofía Peña:	Present
Lucia Regalado:	Present
Aaron Rivera:	Present

### 1. CALL MEETING TO ORDER

Meeting was called to order at 3:01 p.m.

### 2. PUBLIC COMMENT(S)

The following community member(s) address the Board: None

### 3. DISCUSSION OF THE MCALLEN INDEPENDENT SCHOOL DISTRICT STRATEGIC DEVELOPMENT PROCESS PROVIDED BY MOAKCASEY, LLC

Item Submitted: Dr. Albert Canales, Chief Human Resources Officer

For information purposes only

### 4. ADJOURNMENT

Meeting concluded at 4:30 p.m.

---

Board President

---

Board Secretary



## Regular Meeting

Monday, March 9, 2026 5:30 PM

Dr. Ricardo Chapa Board Room/Administration Building of the McAllen Independent School District, 2000 North 23rd Street, McAllen, TX 78501

### Attendance Taken at 5:30 PM.

Robert Carreon:	Present
Erica de la Garza-Lopez:	Present
Roberto Haddad:	Present
Lizzie Kittleman:	Present
Sofia Peña:	Present
Lucia Regalado:	Absent
Aaron Rivera:	Present

### 1. CALL MEETING TO ORDER

The meeting was called to order at 5:30 pm.

### 2. MOMENT OF SILENCE

### 3. PLEDGE OF ALLEGIANCE

### 4. PUBLIC COMMENT(S)

The following community member(s) addressed the Board:

Moises Arjona Jr.(Diabetes and Obesity Prevention-Acanthosis Nigricans Rates for Region 1)

Chelsea Gossett (School Food)

Christine Rovelli (School Nutrition)

Enrique Flores (Student Support Services)

Hershel Patel (Child Nutrition)

### 5. PROCLAMATION(S)

A) Discussion and Possible Action to Adopt the Proclamation Regarding Gifted and Talented Awareness Week (April 6-10, 2026)

Item Submitted: Dr. Rosalba De Hoyos, Associate Superintendent for Instructional Services and Jeanette Nino, Associate Superintendent for Instructional Leadership  
Dr. René Gutiérrez, Superintendent

Motion to adopt the Proclamation Regarding Gifted and Talented Awareness Week.

This motion, made by Trustee Erica de la Garza-Lopez and seconded by Trustee Sofia Peña, Passed.

Robert Carreon: Yea  
 Erica de la Garza-Lopez: Yea  
 Roberto Haddad: Yea  
 Lizzie Kittleman: Yea  
 Sofia Peña: Yea  
 Lucia Regalado: Absent  
 Aaron Rivera: Yea

Yea: 6, Nay: 0, Absent: 1

**6. CONSENT AGENDA ITEMS**

A) Discussion and Possible Action on Request for Proposal No. 2024-1014 Advertising, Marketing, Media and Related Products and Services (Round 4)  
 Item Submitted: Dr. Albert Canales, Chief Human Resources Officer  
 Dr. René Gutiérrez, Superintendent

Motion to approve Request for Proposal No. 2024-1014 Advertising, Marketing, Media and Related Products and Services (Round 4), and award vendors on the attached list, for a coterminous term through June 30, 2027. This motion, made by Trustee Sofia Peña and seconded by Trustee Roberto Haddad, Passed.

Robert Carreon: Yea  
 Erica de la Garza-Lopez: Yea  
 Roberto Haddad: Yea  
 Lizzie Kittleman: Yea  
 Sofia Peña: Yea  
 Lucia Regalado: Absent  
 Aaron Rivera: Yea

Yea: 6, Nay: 0, Absent: 1

**RECOMMENDED VENDORS**

Request for Proposal No. 2024-1014

Advertising, Marketing, Media and Related Products and Services (Round 4)

No.	Vendor Name	City	State	Recommendation
1	Design Dept (Wendy Newton)	Hawkins	TX	Qualified

B) Discussion and Possible Action on Request for Proposal No. 2025-1019 Athletic Equipment, Supplies, Reconditioning Services, and Related Products and Services (Round 7)

Item Submitted: Dr. Albert Canales, Chief Human Resources Officer  
 Dr. René Gutiérrez, Superintendent

Motion to approve Request for Proposal No. 2025-1019 Athletic Equipment, Supplies, Reconditioning Services, and Related Products and Services (Round 7), and approve the companies on the attached list as qualified vendors, for a coterminous term through June 30, 2028. This motion, made by Trustee Sofia Peña and seconded by

Trustee Roberto Haddad, Passed.  
 Robert Carreon: Yea  
 Erica de la Garza-Lopez: Yea  
 Roberto Haddad: Yea  
 Lizzie Kittleman: Yea  
 Sofia Peña: Yea  
 Lucia Regalado: Absent  
 Aaron Rivera: Yea  
 Yea: 6, Nay: 0, Absent: 1

**RECOMMENDED VENDORS**  
**Request for Proposal No. 2025-1019**

**Athletic Equipment, Supplies, Reconditioning Services, and Related Products and Services (Round 7)**

No.	Vendor Name	City	State	Recommendation
1	Inzer Advance Designs Inc.	Longview	TX	Qualified
2	Totalskincare.com, LLC	Rockville	MD	Qualified

C) Discussion and Possible Action on Approval of Request for Proposal No. 2026-1028 Fuel Products and Delivery Services  
 Item Submitted: Lorena Garcia, Deputy Superintendent for Business and Operations  
 Dr. René Gutiérrez, Superintendent  
 Motion to approve Request for Proposal No. 2026-1028 Fuel Products and Delivery Services, and award the vendors on the attached list, for the primary term of one (1) year through April 24, 2027 with the option to renew for three (3) additional one (1) year terms. This motion, made by Trustee Sofia Peña and seconded by Trustee Roberto Haddad, Passed.

Robert Carreon: Yea  
 Erica de la Garza-Lopez: Yea  
 Roberto Haddad: Yea  
 Lizzie Kittleman: Yea  
 Sofia Peña: Yea  
 Lucia Regalado: Absent  
 Aaron Rivera: Yea  
 Yea: 6, Nay: 0, Absent: 1



Participant Name	Address	Contact	Email
AOC Holding Co, Inc dba Arguindegui Oil Co. II, Ltd	6551 STAR COURT LAREDO, TX 78041	Beto Lopez	beto.lopez@argpetro.com
Gold Star Petroleum, Inc	851 E Frontage Rd, US 83 San Juan, Tx 78539	JJ Rodriguez	goldstarpetro@comcast.net
Petroleum Traders Corporation	7120 Pointe Inverness Way Fort Wayne, IN, 46804	Joseph Vanderpool	jvanderpool@petroleumtraders.com
Pinnacle Petroleum, Inc	16651 Gemini Lane Huntington Beach, CA 92647	Liz McKinley	lmckinley@pinnaclepetroleum.com
Tartan Oil LLC	5508 Lonas Dr. Knoxville, TN 37909	Sherry Thomas	GovBiz@Tartanoil.com
Triton Trading, Inc	2501 Parkview Drive, Suite 316 Ft. Worth, Texas 76102	Eliud Betancourt	govaffairs@tritontrading.com

D) Discussion and Possible Action on Request for Proposal No. 2024-1023 Catering, Entertainment, Field Trips, Fundraising, Food, Restaurants, and Rentals (Round 16)  
 Item Submitted: Lorena Garcia, Deputy Superintendent for Business and Operations  
 Dr. René Gutiérrez, Superintendent

Motion to approve Request for Proposal No. 2024-1023 Catering, Entertainment, Field Trips, Fundraising, Food, Restaurants, and Rentals (Round 16), and approve the companies on the attached list as qualified vendors, for a coterminous term through June 30, 2027. This motion, made by Trustee Sofia Peña and seconded by Trustee Roberto Haddad, Passed.

- Robert Carreon: Yea
  - Erica de la Garza-Lopez: Yea
  - Roberto Haddad: Yea
  - Lizzie Kittleman: Yea
  - Sofia Peña: Yea
  - Lucia Regalado: Absent
  - Aaron Rivera: Yea
- Yea: 6, Nay: 0, Absent: 1

**RECOMMENDED VENDORS**

**Request for Proposal No. 2024-1023**

**Catering, Entertainment, Field Trips, Fundraising, Food, Restaurants, and Rentals (Round 16)**

No.	Vendor Name	City	State	Recommendation
1	Cafecitos RGV (Cafecitos RGV LLC)	Pharr	TX	Qualified
2	Feat Travel	Davie	FL	Qualified

**7. INSTRUCTIONAL SERVICES/ INSTRUCTIONAL LEADERSHIP, HUMAN RESOURCES, BUSINESS AND OPERATIONS, AND BOARD OF TRUSTEES ITEMS**

**A) Instructional Services/ Instructional Leadership Item(s) (Dr. Rosalba De**

Hoyos and/or Jeanette Nino)

1. Discussion and Possible Action on Publishers for Math K-12 Textbook Adoption

Item Submitted: Dr. Rosalba De Hoyos, Associate Superintendent for Instructional Services and Jeanette Nino, Associate Superintendent for Instructional Leadership

Dr. René Gutiérrez, Superintendent

Motion to approve the recommended Publishers for the Math K-12 adoption provided in a separate presentation. This motion, made by Sofia Peña and seconded by Aaron Rivera, Passed.

Robert Carreon: Yea  
Erica de la Garza-Lopez: Yea  
Roberto Haddad: Yea  
Lizzie Kittleman: Yea  
Sofia Peña: Yea  
Lucia Regalado: Absent  
Aaron Rivera: Yea

Yea: 6, Nay: 0, Absent: 1

**B) Human Resources Item(s)** (Dr. Albert Canales)

1. Report Regarding Approved Calendar for 2026-2027

Item Submitted: Dr. Albert Canales, Chief Human Resources Officer  
Dr. René Gutiérrez, Superintendent

For information purposes only.

2. Discussion and Possible Action to Correct the Contract Term for Request for Proposal No. 2026-1006 Fully Insured Dental Plan

Item Submitted: Dr. Albert Canales, Chief Human Resources Officer  
Dr. René Gutiérrez, Superintendent

Motion to correct the Contract Term for Request for Proposal No. 2026-1006 Fully Insured Dental Plan to reflect December 31, 2028, as the contract end date. This motion, made by Trustee Roberto Haddad and seconded by Trustee Aaron Rivera, Passed.

Robert Carreon: Yea  
Erica de la Garza-Lopez: Yea  
Roberto Haddad: Yea  
Lizzie Kittleman: Yea  
Sofia Peña: Yea  
Lucia Regalado: Absent  
Aaron Rivera: Yea

Yea: 6, Nay: 0, Absent: 1

**C) Business and Operations Item(s)** (Lorena Garcia)

1. Discussion and Possible Action of the McAllen Independent School District February Budget Amendment for Fiscal Year Beginning July 1, 2025 and Ending June 30, 2026

Item Submitted: Lorena Garcia, Deputy Superintendent for Business and Operations

Dr. René Gutiérrez, Superintendent

Motion to approve the McAllen Independent School District February Budget Amendment for the General Fund and Capital Projects Fund for Fiscal Year Beginning July 1, 2025 and Ending June 30, 2026. This motion, made by Trustee Erica de la Garza-Lopez and seconded by Trustee Sofia Peña, Passed.

Robert Carreon: Yea  
Erica de la Garza-Lopez: Yea  
Roberto Haddad: Yea  
Lizzie Kittleman: Yea  
Sofia Peña: Yea  
Lucia Regalado: Absent  
Aaron Rivera: Yea

Yea: 6, Nay: 0, Absent: 1

2. Report Regarding Interlocal Agreement No. 2026-237 Community Development Block Grant (CDBG) Funding for Community Parking Lot at Dorothea Brown Middle School with the City of McAllen

Item Submitted: Lorena Garcia, Deputy Superintendent for Business and Operations

Dr. René Gutiérrez, Superintendent

For information purposes only.

#### D) Board of Trustees Item(s)

1. Discussion and Possible Action on Approval of Board of Education Meeting Minutes:

Special Board Meeting - February 24, 2026

Regular Board Meeting - February 24, 2026

Motion to approve Board of Education meeting minutes as listed. This motion, made by Trustee Robert Carreon and seconded by Trustee Sofia Peña, Passed.

Robert Carreon: Yea  
Erica de la Garza-Lopez: Yea  
Roberto Haddad: Yea  
Lizzie Kittleman: Yea  
Sofia Peña: Yea  
Lucia Regalado: Absent  
Aaron Rivera: Yea

Yea: 6, Nay: 0, Absent: 1

**8. RECESS TO CLOSED SESSION: Board of Trustees may go into Closed Session pursuant to Section(s) 551.071, 551.072, 551.074, 551.076, and 551.089 Texas Government Code, to discuss the following:**

Meeting recessed to closed session at 6:12 pm

A) Discussion and Possible Action of Human Resources Recommendation(s) for

School Year 2025-2026

B) Discussion of Human Resources Employee Resignation(s) and Retirees for School Year 2025-2026

C) Discussion Regarding School Safety and Security

1. Discussion of the Texas Education Agency Intruder Detection Audit
2. Discussion of the Standard Operating Procedure, Weekly Exterior Door Inspection and Reporting

D) Pending and/or Potential Litigation

E) Possible Real Estate Acquisition

**9. RECONVENE IN OPEN SESSION**

**10. ACTION ON ITEM(S) IN CLOSED SESSION**

Meeting reconvened at 6:33pm.

A) Discussion and Possible Action of Human Resources Recommendation(s) for School Year 2025-2026

Item Submitted: Dr. Albert Canales, Chief Human Resources Officer  
Dr. René Gutiérrez, Superintendent

Motion to approve Human Resources Recommendation(s) for School Year 2025-2026. This motion, made by Trustee Roberto Haddad and seconded by Trustee Erica de la Garza-Lopez, Passed.

Robert Carreon:	Yea
Erica de la Garza-Lopez:	Yea
Roberto Haddad:	Yea
Lizzie Kittleman:	Yea
Sofía Peña:	Yea
Lucia Regalado:	Absent
Aaron Rivera:	Yea

Yea: 6, Nay: 0, Absent: 1

B) Discussion of Human Resources Employee Resignation(s) and Retirees for School Year 2025-2026

Item Submitted: Dr. Albert Canales, Chief Human Resources Officer  
Dr. René Gutiérrez, Superintendent

C) Discussion Regarding School Safety and Security

1. Discussion of the Texas Education Agency Intruder Detection Audit
2. Discussion of the Standard Operating Procedure, Weekly Exterior Door Inspection and Reporting

D) Pending and/or Potential Litigation

E) Possible Real Estate Acquisition

**11. SCHEDULED MEETINGS**

- A. Board Workshop March 11, 2026 - 5:30 pm - Administration Building/Dr. Ricardo Chapa Board Room
- B. Board Workshop(Student Recognition) March 24, 2026 - 5:30 pm - McAllen High School Auditorium
- C. Budget Workshop #3 April 7, 2026 - 5:30 pm - TBD
- D. Regular Board Meeting April 14, 2026 - 5:30 pm - Administration Building/Dr.

Ricardo Chapa Board Room

**12. ADJOURNMENT**

Motion to adjourn meeting at 6:34 pm. This motion, made by Trustee Roberto Haddad and seconded by Trustee Erica de la Garza-Lopez, Passed.

Robert Carreon:	Yea
Erica de la Garza-Lopez:	Yea
Roberto Haddad:	Yea
Lizzie Kittleman:	Yea
Sofia Peña:	Yea
Lucia Regalado:	Absent
Aaron Rivera:	Yea
Yea: 6, Nay: 0, Absent: 1	

---

Board President

---

Board Secretary



## Board Workshop

Wednesday, March 11, 2026 5:30 PM

Dr. Ricardo Chapa Board Room/Administration Building of the McAllen Independent School District, 2000 North 23rd Street, McAllen, TX 78501

### Attendance Taken at 5:30 PM.

Robert Carreon: Present  
Erica de la Garza-Lopez: Present  
Roberto Haddad: Present  
Lizzie Kittleman: Present  
Sofía Peña: Present  
Lucia Regalado: Absent  
Aaron Rivera: Present

Mr. Robert Carreon attended via TEAMS

### 1. CALL MEETING TO ORDER

Meeting was called to order at 5:30 pm.

### 2. PUBLIC COMMENT(S)

The following community member(s) addressed the Board: None

### 3. DISCUSSION OF PURCHASING SCORING MATRIX

Item Submitted: Lorena Garcia, Deputy Superintendent Business and Operations  
Dr. René Gutiérrez, Superintendent

For information purposes only.

### 4. ADJOURNMENT

Motion to adjourn meeting at 7:04 p.m. This motion, made by Trustee Sofia Peña and seconded by Trustee Roberto Haddad, Passed.

Robert Carreon: Yea  
Erica de la Garza-Lopez: Yea  
Roberto Haddad: Yea  
Lizzie Kittleman: Yea  
Sofía Peña: Yea  
Lucia Regalado: Absent  
Aaron Rivera: Yea

Yea: 6, Nay: 0, Absent: 1

---

Board President

---

Board Secretary



## Board Workshop

Monday, March 23, 2026 5:30 PM

Dorothea Brown Middle School Library, 2700 South Ware Road, McAllen, Texas 78501

Attendance Taken at 5:30 PM.

Robert Carreon:	Present
Erica de la Garza-Lopez:	Present
Roberto Haddad:	Present
Lizzie Kittleman:	Present
Sofía Peña:	Present
Lucia Regalado:	Present
Aaron Rivera:	Present

### 1. CALL MEETING TO ORDER

Meeting was called to order at 5:31 pm.

### 2. PUBLIC COMMENT(S)

The following community member(s) addressed the Board:

Hershel Patel (Budget/Child Nutrition)

### 3. DISCUSSION OF 2026-2027 BUDGET: STAFFING AND COMPENSATION

-Pay System Maintenance Report by Texas Association of School Boards (TASB)

-Student Enrollment

-Recruitment and Retention Efforts

-Stipends

-Budget Outlook

Item Submitted: Lorena Garcia, Deputy Superintendent Business and Operations

Dr. René Gutiérrez, Superintendent

For information purposes only.

### 4. ADJOURNMENT

Motion to adjourn meeting at 7:29 pm. This motion, made by Trustee Sofia Peña and seconded by Aaron Rivera, Passed.

Robert Carreon: Yea

Erica de la Garza-Lopez: Yea

Roberto Haddad: Yea

Lizzie Kittleman: Yea  
Sofia Peña: Yea  
Lucia Regalado: Yea  
Aaron Rivera: Yea  
Yea: 7, Nay: 0

---

Board President

---

Board Secretary



## Workshop

Tuesday, March 24, 2026 5:30 PM

Auditorium/McAllen High School, 2021 La Vista, McAllen, TX 78501

Attendance Taken at 5:30 PM.

Robert Carreon:	Present
Erica de la Garza-Lopez:	Absent
Roberto Haddad:	Present
Lizzie Kittleman:	Present
Sofía Peña:	Absent
Lucia Regalado:	Present
Aaron Rivera:	Present

### 1. CALL MEETING TO ORDER

Meeting was called to order at 5:30 pm.

### 2. PUBLIC COMMENT(S)

The following community member(s) addressed the Board: None

### 3. INSTRUCTIONAL SERVICES

A) Recognition of the 2026 District Spelling Bee Winners

Item Submitted: Dr. Rosalba De Hoyos, Associate Superintendent for Instructional Services and Jeanette Nino, Associate Superintendent for Instructional Leadership

Presenter: Dr. René Gutiérrez, Superintendent

B) Recognition of the Battle of the Books District and Regional Winners

Item Submitted: Dr. Rosalba De Hoyos, Associate Superintendent for Instructional Services and Jeanette Nino, Associate Superintendent for Instructional Leadership

Presenter: Dr. René Gutiérrez, Superintendent

C) Recognition of the Elementary District Science Olympiad Winners

Item Submitted: Jeanette Nino, Associate Superintendent for Instructional Leadership

Presenter: Dr. René Gutiérrez, Superintendent

### 4. ATHLETICS

A) Recognition of McAllen Memorial High School Athletics

Item Submitted: Brian McClenny, Director of Athletic Department

Presenter: Dr. René Gutiérrez, Superintendent

B) Recognition of James "Nikki" Rowe High School Athletics  
Item Submitted: Brian McClenny, Director of Athletic Department  
Presenter: Dr. René Gutiérrez, Superintendent

C) Recognition of McAllen High School Athletics  
Item Submitted: Brian McClenny, Director of Athletic Department  
Presenter: Dr. René Gutiérrez, Superintendent

**5. FINE ARTS**

A) Recognition of McAllen High School Vertical Team/Fine Arts  
Item Submitted: Debra Loya, Director of Fine Arts Department  
Presenter: Dr. René Gutiérrez, Superintendent

B) Recognition of McAllen Memorial High School Vertical Team/Fine Arts  
Item Submitted: Debra Loya, Director of Fine Arts Department  
Presenter: Dr. René Gutiérrez, Superintendent

C) Recognition of James "Nikki" Rowe High School Vertical Team/Fine Arts  
Item Submitted: Debra Loya, Director of Fine Arts Department  
Presenter: Dr. René Gutiérrez, Superintendent

**6. ADJOURNMENT**

Motion to adjourn at 6:34 pm. This motion, made by Trustee Aaron Rivera and seconded by Trustee Lucia Regalado, Passed.

Robert Carreon: Yea

Erica de la Garza-Lopez: Absent

Roberto Haddad: Yea

Lizzie Kittleman: Yea

Sofia Peña: Absent

Lucia Regalado: Yea

Aaron Rivera: Yea

Yea: 5, Nay: 0, Absent: 2

---

Board President

---

Board Secretary

**BOARD AGENDA REPORT  
MCALLEN INDEPENDENT SCHOOL DISTRICT**

**MEETING DATE:** April 14, 2026

**SUBJECT:** Discussion and Possible Action of Travel by the Board of Trustees

**REFERENCE:** Goal 2 - People Development

**BACKGROUND INFORMATION/REASON FOR BOARD CONSIDERATION:**

Policy requires Board Members to submit travel requests to the Board in advance when practical. The Board plans to attend the Region One 2026 Spring School Board Conference, May 15 - 16, 2026, South Padre Island, TX

**ADMINISTRATIVE CONSIDERATIONS/FACTS AND ANALYSIS:**

The Board of Trustees will report on the following trip(s):

- Region One 2026 Spring School Board Conference, May 15 - 16, 2026, South Padre Island, TX
  - Fee \$350.00
  - Hotel \$140.00 per night

**LEGAL REVIEW:**

None

**BUDGETARY CONSIDERATIONS:**

Funds for this trip have been allocated through the Board of Trustees' Budget

**RECOMMENDED BOARD ACTION:**

That the Board of Trustees approve the travel request to attend the Region One 2026 Spring School Board Conference, May 15 - 16, 2026, South Padre Island, Texas.

**Attachment:**

**SUBMITTED BY:** 

**SUPERVISOR:** 

For further information contact:  
Name: Norma Ramirez  
Office: (956) 688-5418  
Email: norma.ramirez@mcallsisd.net

**Approved for presentation to the Board of Education:**

  
RENE GUTIERREZ (Apr 1, 2026 14:21:31 CDT)

Please log in to register for this workshop. ✕

# Workshop Registration Details

---

**Workshop Id**

395239

**Workshop Title**

Region One 2026 Spring School Board Conference

Complete Attendance not available before workshop starts.

**Description**

This conference provides School Board Members and Superintendents with invaluable leadership development, strategic insights, and networking opportunities to help improve their schools and communities. Creating a meaningful and enriching experience for these dedicated educators.

**Audience**

School Board of Directors, School Superintendents, Executive TEAM

**Fee**

\$350.00

**Max Participants**

500

**Min Participants**

50

**Registered**

143

**CPE Hours**

1

**Stipend**

No

## Content Area

Administration & Leadership  
School Board

## COOPs

...There are no COOPs...

## Workshop Materials

Title
...There are no workshop materials...

## Dates, Times and Locations

Room Name	Workshop Date	Begin Time	End Time
South Padre Island Convention Center	5/15/2026 - 5/16/2026	11:00 AM	05:00 PM

## Workshop Contacts

Name	Type	E-Mail	Phone
Dr. Judith M. Solis	Presenter	jsolis@esc1.net (mailto:jsolis@esc1.net)	
Perla Pulido	Contact	ppulido@esc1.net (mailto:ppulido@esc1.net)	(956) 984-6002
Angie Iglesias	Contact	aiglesias@esc1.net (mailto:aiglesias@esc1.net)	(956) 984-6005
Perla Pulido	Billing Contact	ppulido@esc1.net (mailto:ppulido@esc1.net)	(956) 984-6002

### Special Accommodations



To request an accommodation, please contact one of the following workshop contacts at least 30 business days prior to the event:

- Perla Pulido (mailto:ppulido@esc1.net) - (956) 984-6002
- Angie Iglesias (mailto:aiglesias@esc1.net) - (956) 984-6005



**BOARD AGENDA REPORT  
MCALLEN INDEPENDENT SCHOOL DISTRICT**

**MEETING DATE:** April 14, 2026

**SUBJECT:** Discussion and Possible Action on Human Resources Recommendation(s) for School Year 2025-2026

**REFERENCE:** Goal 2: People Development; Strategy 2: Attract/Retain High Quality Staff

**BACKGROUND INFORMATION/REASON FOR BOARD CONSIDERATION:**

McAllen Independent School District utilizes a comprehensive hiring system that screens, evaluates and recommends the "best" candidates with the skill sets to maximize student learning. All recommended candidates meet compliance with State Law requirements, that is to increase the academic achievement of all students by helping campuses and district improve teacher quality.

**ADMINISTRATIVE CONSIDERATIONS/FACTS AND ANALYSIS:**

Considerations are made in accordance with Board Policy DC (LEGAL) and District Staffing Guidelines. Individual(s) to be identified under separate cover.

**LEGAL REVIEW:**

Not Applicable.

**BUDGETARY CONSIDERATIONS:**

Provided with individuals identified under separate cover.

**RECOMMENDED BOARD ACTION:**

That the Board of Trustees approve Human Resources Recommendation(s) for School Year 2025-2026.

**Attachment:**

**SUBMITTED BY:**   
Alberto Canales (Apr 1, 2026 10:38:47 CDT)

**SUPERVISOR:** *Lorena Garcia*  
Lorena Garcia (Apr 1, 2026 11:28:57 CDT)

For further information contact:  
Name: Dr. Albert Canales, Chief Human Resources Officer  
Office: (956) 618-6009  
Email: albert.canales@mcallenisd.net

**Approved for presentation to the Board of Education:**

  
RENE GUTIERREZ (Apr 1, 2026 13:36:46 CDT)  
144  
**Superintendent of Schools**

**BOARD AGENDA REPORT  
MCALLEN INDEPENDENT SCHOOL DISTRICT**

**MEETING DATE:** April 14, 2026

**SUBJECT:** Discussion of Human Resources Employee Resignation(s) and Retirees for School Year 2025-2026

**REFERENCE:** Goal 2: People Development; Strategy 2: Attract/Retain High Quality Staff

**BACKGROUND INFORMATION/REASON FOR BOARD CONSIDERATION:**

Employees desiring to voluntarily separate from the school district for reasons such as retirement, relocation or other such reasons provide written notice to their immediate supervisor and the Human Resources Department. All resignations include current position, work site and date resignation is to be effective.

**ADMINISTRATIVE CONSIDERATIONS/FACTS AND ANALYSIS:**

Human Resources Department shall notify all appropriate personnel of the resignation, including the Payroll Department. All vacant positions will be closely reviewed by corresponding department administration, along with aligning to staffing guidelines and addressing staffing needs in determining position status.

**LEGAL REVIEW:**

Not Applicable

**BUDGETARY CONSIDERATIONS:**

Not Applicable

**RECOMMENDED BOARD ACTION:**

This item is for information only. No Board action required.

**Attachment:**

**SUBMITTED BY:**   
Alberto Canales (Apr 1, 2026 10:38:28 CDT)

**SUPERVISOR:** *Lorena Garcia*  
Lorena Garcia (Apr 1, 2026 11:28:05 CDT)

For further information contact:  
Name: Dr. Albert Canales, Chief Human Resources Officer  
Office: (956) 618-6009  
Email: alberto.canales@mcallenisd.net

**Approved for presentation to the Board of Education:**

  
RENE GUTIERREZ (Apr 1, 2026 13:37:20 CDT)

145

**Superintendent of Schools**