



**Cutting
Systems**

Proposal TORCHMATE 5100 CNC PLASMA TABLE

Prepared By:

Quote #

Prepared For:

Date:

Customer Email:

Cust Phone #

Distributor/Integrator

TSR:

Performance in Motion

The Torchmate® 5100 CNC plasma cutting system by Lincoln Electric® is a single source engineered plasma cutting table developed to deliver exceptional repeatability, accuracy, and speed. Rapid delivery and setup time get your machine up and running quickly. Our industry-leading support and low operational costs ensure you spend more time making money.

The Torchmate 5100 is available in multiple configurations and includes all of the components needed to operate the system, including an integrated touchscreen HMI, shape library, motion control system and plasma power supply.



Image Represents LECS-200-5100-WB configuration.

Starting at

\$81,999

Does not include options, freight, installation, or onsite training.

Finance your investment starting at

\$1,633^{.34}
per month o.a.c.

NOTICE: THIS PROPOSAL IS CONTINGENT ON A LACK OF IMPACT BY THE CORONAVIRUS NATIONAL EMERGENCY. Given the existence of the coronavirus pandemic, Lincoln Electric Cutting Systems will use its best efforts to manufacture, staff and service this project to meet the scheduled delivery date(s). However, Lincoln Electric Cutting Systems reserves its right to seek an excusable extension of time if Lincoln Electric Cutting Systems or its subcontractors or suppliers are unable to meet their contractual obligations due to the illness, supply shortages or governmental restraints on business, travel and/or assembly. To the extent that the project is suspended, Lincoln Electric Cutting Systems reserves its right to seek additional costs associated with the suspension.

Complete Quote on Page 3

CHOOSE YOUR CONFIGURATION



MULTI-ZONE DOWNDRAFT TABLE

Multi-zone downdraft table pulls fumes away for clean and efficient operation only in the cutting area it is needed in.



WATER TABLE

A water table allows you to capture the majority of debris from the cutting process and also cools your parts quickly.

CHOOSE YOUR POWER



FLEXCUT® 125 125 Amp Plasma 1" CUT CAPACITY (MILD STEEL)

Powerful conventional air plasma. Bevel capability is available.



FINELINE® 170HD* 170 Amp HD Plasma 1.25" CUT CAPACITY (MILD STEEL)

High Definition system that offers exceptional pierce, cut, and marking capabilities. Upgrade for faster cut speeds, sharp edges, reduced kerf lines, and nearly dross-free cuts.

*Available 2021**



FLEXCUT® 200 200 Amp Plasma

1.25" CUT CAPACITY (MILD STEEL)
New CLEANSTRIKE® technology offers an advanced plasma arc starting process for improved cut quality.



FINELINE® 300HD 300 Amp HD Plasma 1.75" CUT CAPACITY (MILD STEEL)

Maximize the performance of the FineLine High Definition system with increased capacity.

CHOOSE YOUR TOOLS*



* 5100 supports three tools without bevel

ROTATING BEVEL HEAD ATTACHMENT

±45° bevel cutting capability to increase the surface area of the edge for weld prep and final assembly. Bevel angle dependent on material thickness and power supply. See page seven for details. Available for FlexCut series plasmas only*



actual Prism® fume extraction system may vary

CHOOSE YOUR ACCESSORIES

OPTIONAL FUME CONTROL SYSTEM

The fume control system can be attached to the downdraft machine to enable safe handling of fumes.

OXYFUEL & MOTORIZED LIFTER

Cost-effective cutting for up to 4" thick mild steel.



**Cutting
Systems**



**Cutting
Systems**

PROPOSAL TORCHMATE 5100- CNC PLASMA TABLE

Date:

Quote Valid For 30 Days

Quote #

TORCHMATE 5100 CNC PLASMA SYSTEMS AND ACCESSORIES

MACHINE	POWER SUPPLY	VOLTAGE
Torchmate 5100 - CNC Plasma Cutting WaterTable	FlexCut 125 Amp CNC Plasma	
Torchmate 5100 - CNC Plasma Cutting DowndraftTable	FlexCut 200 Amp CNC Plasma	
TOOLS	Fineline 170 HD CNC Plasma	
Rotating Bevel Head Attachment (includes bevel software)	Fineline 300 HD CNC Plasma	
Table Part #		

Machine Total

ACCESSORIES AND OPTIONS	QTY	
Fume Control System		\$19,999
Motorized Lifter Oxy Acetylene Torch (Manual Gas Control)		\$3,548.14
Quick-Disconnect Torch Head		
Consumable Starter Kit - 1 Free With Machine Purchase		

SOFTWARE

VMDnest (included)		
QuickCAM Offline Nesting Package		\$3,000.00
QuickCAM Bevel (Included with Bevel)		
Lincoln Electric PlateGuard™ (55 Gallon Drum)		\$1,620.30

Accessories Total

TRAINING

Onsite Plasma Commissioning & Training		\$4,750.00
Onsite High Definition Commissioning & Training		\$6,000.00
Optional Torchmate Academy Online Training, 90 Days		\$500.00

Training Total

CUSTOMER NAME

CONTACT

EMAIL

SHIPPING ADDRESS

REQUESTED SHIPPING DATE	Mileage	Shipping Total
FOB Reno to Hawaii Alaska International FOB S.F.		Subtotal
PO #	Date	Tax %
Card Holder	CW	Grand Total
Billing Address	I have been made aware of my Training Options, Plasma Cutter Power Requirements, Shipping/Unloading Requirements, Site Prep Guide and Terms and Conditions. Customer Signature	
Phone Number		
Sales Associate		
TSR		
Distributor		
Distributor Contact		

This quote is valid for 30 days, and is governed by Seller's Terms and Conditions of Sale attached hereto and/or located at the website indicated below. Any reference to Buyer's request for quote incorporates only the technical information described therein. ALL TERMS AND CONDITIONS IN BUYER'S REQUEST FOR PROPOSAL/QUOTE ARE DEEMED MATERIAL ALTERATIONS AND ARE HEREBY EXPRESSLY REJECTED. Seller's Website: Torchmate.com



Image shown with optional bevel cutting head

SYSTEM INCLUDES

- Complete 5x10 Multiple Station Cutting Area CNC Plasma Table
- Ohmic Initial Height Sense with Automatic Torch Arc-Voltage Height Control
- Dual-Channel Safety System Supporting Emergency Stop Switch
- Optional $\pm 45^\circ$ Bevel Cutting Head (dependent on power supply and material thickness.)
- Conventional or HD Plasma available
- Next Generation Digital Height Control w/ Corner Lockout
- Torch Breakaway
- Visual Machine Designer Software and Shape Library
- DXF & DWG Importer (use with most CAD programs)
- Integrated Down Draft or Water Table
- Industrial Touchscreen HMI
- Consumable Starter Kit
- Technical Phone Support

TABLE SPECIFICATIONS

Input Power

- 120V / 1Ph / 60Hz Machine
- 380-575V / 3Ph / 50-60Hz

Machine Size

- 60" x 120" (1524mm x 3048mm) Cutting Area
- 113.5" x 166" (2882.9mm x 4216.4mm) Footprint

Plate Capacity

- Holds Up to 4" (102mm) 5'x10' (1524mm x 3048mm) Plate Mild Steel

Weight [Configuration Dependent.]

- Estimated 6,600 lbs [2993.71 kg] dry shipping weight

Motors

- Servo Motors Fitted with Rotary Glass Encoders

Drive System

- Helical Gear Rack and Hardened Pinion with Lubrication System

Linear Guidance

- Profile Linear Rail

Acceleration Rate

- 0.08g (0.06g bevel)

Deceleration Rate

- 0.08g (0.06g bevel)

Height Control

- Ohmic Sensing
- Automatic Torch Arc Voltage Height Control
- 6" Z-axis Travel

Bevel Cutting Capabilities

- $\pm 45^\circ$ Cut, Dependent on Material Thickness and Plasma Configuration

Software

- Easy-To-Use Lincoln Electric User Interface
- Optional CAD/CAM with Irregular Part Nesting

Fume Extraction (Optional Accessory)

- 1,030 to 1,438 ft³/min or 61,800 to 89,990 ft³/hr
- Automatic Filter Cleaning, Pressure Controlled

Downdraft Configuration

- Multiple Zones Controlled By Motion Controller

Safety

- Dual-Channel Safety System Supporting Emergency Stop Switch
- Safety System Extended To External Peripherals
- External Drive Power On Switch

Machine Construction

- Fabricated Steel Frame with Powder Coated Finish

Warranty

- 1 Year Machine Warranty
- 3 Year Power Supply Warranty

CHOOSE YOUR LOCATION

When installing a Lincoln Electric CNC Cutting System in your shop, there are many factors that will influence the potential productivity, ease of use of the machine and the safety of the operator. The main factors to prepare for include the physical layout and placement of the machine in the shop, the availability of power, an EMI ground, compressed air and other gases, and ventilation.

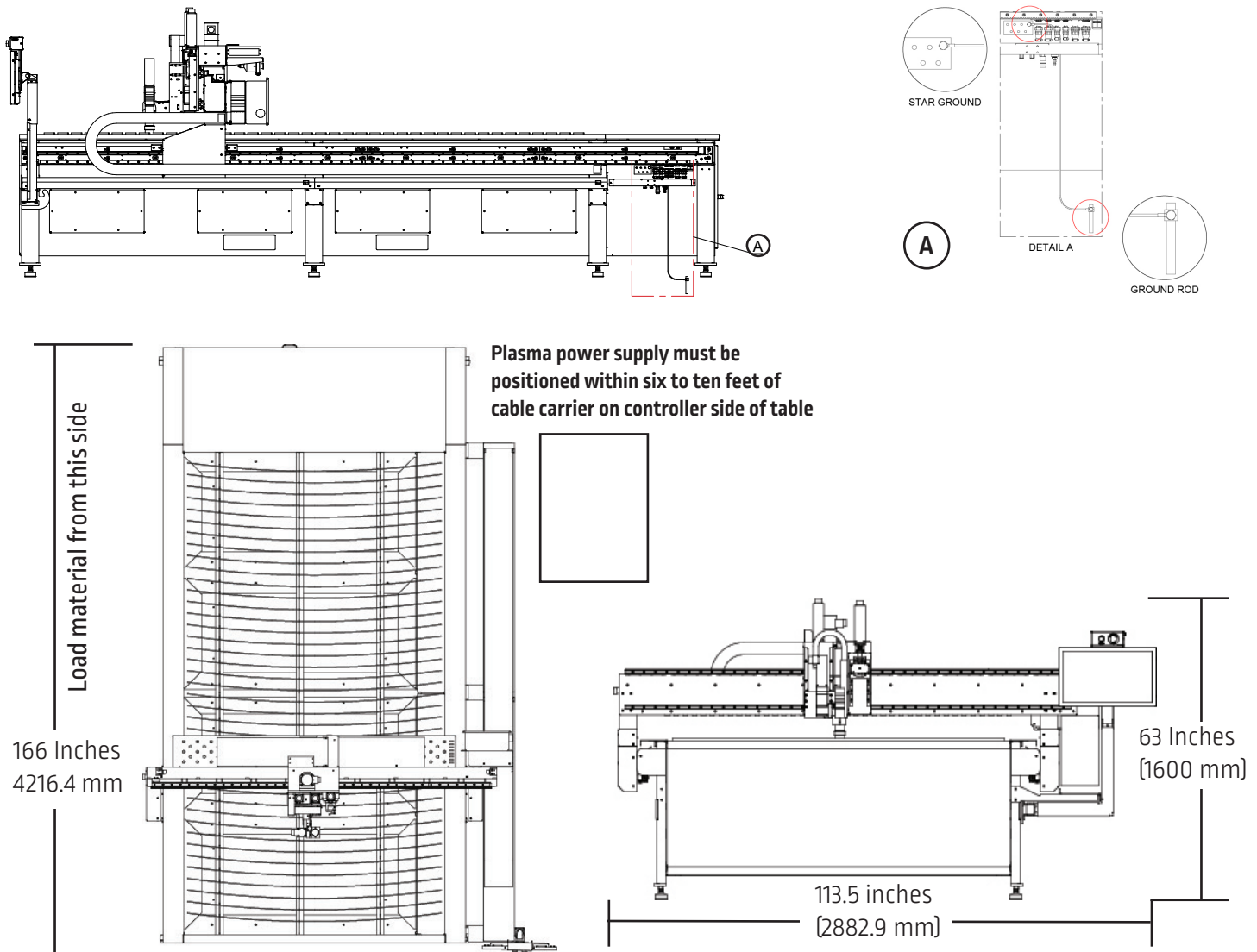

MAINTAIN YOUR WORK AREA

- When preparing to install the Lincoln Electric CNC Cutting System, provide sufficient space. Three feet of work space should be maintained at the front of the machine
- Forklift load material opposite the cable carrier only. Utilize the back of the machine to park the gantry while loading material.
- A dedicated earth ground must be provided and should be installed in a manner to reduce trip hazard
- The table power leads included is limited to 10 feet.

CHOOSE YOUR CONFIGURATION

Torchmate 5100 configuration is available as an HMI controlled variable level water table or a multizone downdraft table.

WATER TABLE

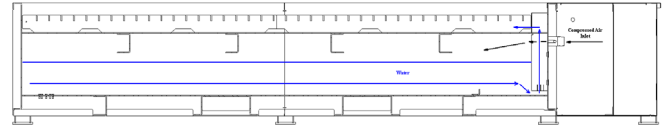

Variable water level tables allow the capture of a portion of the fume, particulate and debris from the cutting process without the integration of a filtration system. The water table accelerates the cooling of parts and limits distortions caused by heat in the workplace. The Torchmate 5100 allows the operator to adjust water table levels from the HMI operators control for immersed cutting applications or quenching of material. Water table configurations include replaceable steel slats for the placement of material to be cut. Torchmate 5100 water tables come equipped with a pressurized water storage tank that allows removal of water from the cutting bed during maintenance and cleaning procedures. Consideration of anti-corrosive additives may improve water quality in water table applications; aluminum cutting is not suitable for water tables equipped with storage tanks. Water table plasma cutting machines should not be placed in confined spaces, and adequate ventilation must be provided during cutting operation.

MULTI-ZONE DOWNDRAFT TABLE

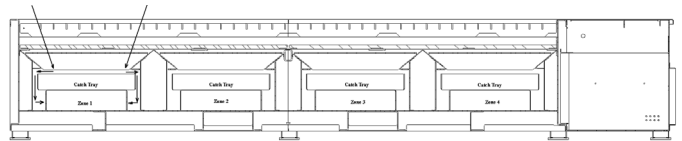

Multi-zone downdraft tables pull fume into the material bed to facilitate dry cutting operation and fume control via a secondary ventilation system. Mechanical zone control is maintained via the Torchmate 5100 motion control to ensure optimum extraction irrespective of the size of the material loaded on the machine bed. Zones are divided along the length of the bed to allow concentrated fume removal in alignment with the torch location. The fourteen-inch exhaust duct located at the back of the table requires connection to an optional 1,030 ft³/min or 61,800 ft³/hr ventilation system. Downdraft applications are encouraged for our FineLine 300HD plasma power supplies and applications that include aluminum cutting. Torchmate 5100 downdraft tables include consumable steel slats and expanded metal parts capture for easy replacement.

CHOOSE YOUR POWER

1" CUT CAPACITY



FLEXCUT® 125

1.25" CUT CAPACITY



FLEXCUT® 200

1.25" CUT CAPACITY

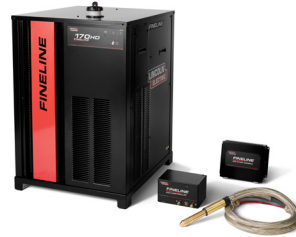

FINELINE® 170HD

1.75" CUT CAPACITY



FINELINE® 300HD

Plasma Power Supply 125 Amp Plasma 200 Amp Plasma 170 Amp HD Plasma 300 Amp HD Plasma

PRODUCTION CUTTING CAPACITY

Mild Steel	1" [25mm]	1.25" [32mm]	1.25" [32mm]	1.75" [45mm]
Stainless Steel	3/4" [20mm]	3/4" [20mm]	1" [25mm]	1.25" [32mm]
Aluminum	1" [25mm]	3/4" [20mm]	1" [25mm]	1" [25mm]

PLASMA MARKING

Yes	Yes	Yes	Yes
-----	-----	-----	-----

CUTTING SPEED RATED OUTPUT CURRENT*

1/4" [6 mm] Mild Steel	210 ipm [5334 mm/min] 125A, Air/Air	200 ipm [5250 mm/min] 200A, Air/Air	230 ipm [6075 mm/min] 170A, Oxygen/Air	230 ipm [6075 mm/min] 200A, Oxygen/Air
1/2" [12mm] Mild Steel	88 ipm [2235 mm/min] 125A, Air/Air	110 ipm [2950 mm/min] 200A, Air/Air	120 ipm [3200 mm/min] 170A, Oxygen/Air	135 ipm [3550 mm/min] 300A, Oxygen/Air
1" [25 mm] Mild Steel	32 ipm [812 mm/min] 125A, Air/Air	40 ipm [1050 mm/min] 200A, Air/Air	50 ipm [1300 mm/min] 170A, Oxygen/Air	70 ipm [1800 mm/min] 300A, Oxygen/Air
1.25" [32 mm] Mild Steel	NA	25 ipm [625 mm/min] 200A, Air/Air	30 ipm [900 mm/min] 170A, Oxygen/Air	50 ipm [1400 mm/min] 300A, Oxygen/Air
1.5" [38 mm] Mild Steel	NA	N/A	N/A	37 ipm [950 mm/min] 300A, Oxygen/Air

PROCESS AMPS

10A - 125A	10A - 200A	10A - 170A	10A - 300A
------------	------------	------------	------------

CUTTING GAS

Mild Steel	Air/Air	Air/Air, Oxygen/Air	Oxygen/Air, Oxygen/Oxygen	Oxygen/Air, Oxygen/Oxygen
Stainless Steel	Air/Air, Nitrogen/Nitrogen	Air/Air, Air/Nitrogen	Air/Air, Air/Nitrogen, H17/Nitrogen	Air/Air, Air/Nitrogen, H17/Nitrogen
Aluminum	Air/Air	Air/Air, Air/Nitrogen	Air/Nitrogen	Air/Nitrogen

INPUT VOLTAGE

380-400-415/460/575V 3Ph 50/60Hz	380-400-415/460/575V 3Ph 50/60Hz	380-415/460/575V 3Ph 50/60Hz	380-415/460/575V 3Ph 50/60Hz
380-400-415V 3Ph 50/60Hz [CE]	380-400-415V 3Ph 50/60Hz [CE]	380-415V 3Ph 50/60Hz [CE]	380-415V 3Ph 50/60Hz [CE]

* Cut speeds for best quality, production results may vary.

- **VMDnest (Standard)**

VMDnest provides the machine operator with onboard single-sheet nesting capabilities. Bring multiple DXF or DWG's directly to the machine from your CAD software and have the operator nest them to a sheet, no offline software required. VMDnest provides an efficient nesting algorithm for placing many components onto a user-defined material sheet, providing material utilization feedback to the operator live. VMDnest automatically programs cut parameters to the g-code file for important cutting parameters, such as Feedrate, Pierce Height, and Cut Height. This programming prevents the need of the operator to reference a cut chart when programming cuts, and eliminates potential human error in having incorrect variables programmed before executing a program.

- **QuickCAM (Optional)**

QuickCAM offline nesting provides a top-tier multi-sheet nesting platform, allowing the user to define total quantities of parts, sheets, and sheet sizes. An entire job can be nested spanning multiple material types/thicknesses in one nest. Quote parts and jobs accurately knowing the raw material requirement before the post reaches the machine. QuickCAM automatically programs cut parameters to the g-code file for important cutting parameters, such as Feedrate, Pierce Height, and Cut Height. This programming prevents the need of the operator to reference a cut chart when programming cuts, and eliminates potential human error in having incorrect variables programmed before executing a program. User-defined sheet optimization (nesting efficiency, rotation options, nesting order, etc.) for the most precise and efficient use of material stock. QuickCAM can provide multiple g-code files for the machine from the drafter's seat. QuickCAM also includes a basic CAD package, for modifying or cleaning DXF and DWG files from other CAD software before applying tool paths.

- **QuickCAM Bevel (Included with Optional Bevel)**

QuickCAM Bevel is included with our bevel head tooling option and includes the QuickCAM features. The 3D module is designed with an intuitive interface that is that is easy to use and has all of the features you need in 5 axis beveling software. Software includes six pre-programmed bevel designs and four pre-programmed bevel angles. [Example on page 9]

	VMD Nest	QuickCAM	QuickCAM Bevel	Quickduct CAM Master
CAD		●	●	●
CAM	●	●	●	●
Single Sheet Nesting	●	●	●	●
Multi Sheet Nesting		●	●	●
Integrated Cut Charts	●	●	●	●
Bevel Software			●	
Basic Shapes Library	●			
HVAC Fittings Library				●

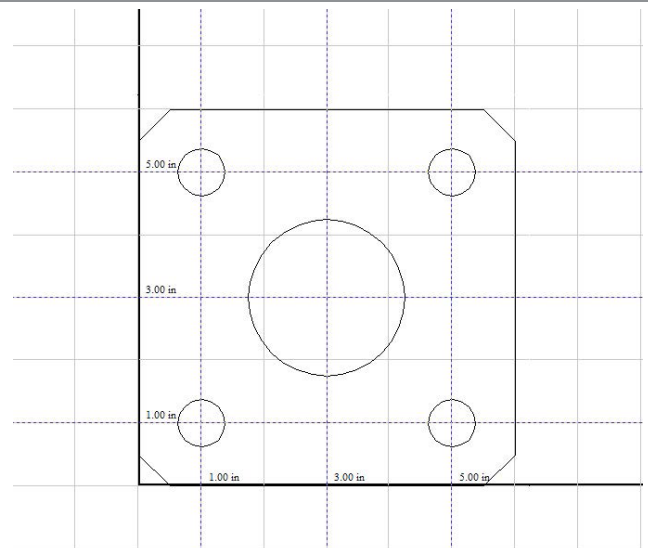

CHOOSE YOUR BEVEL CUTS

The bevel head option gives you the ability to create weld prepped parts much faster and easier than any manual method. This option gives you huge improvements in productivity and efficiency by eliminating secondary beveling processes. The bevel head is able to operate at $\pm 45^\circ$ angles and is preprogrammed for $15^\circ - 22.5^\circ - 30^\circ - 38.5^\circ$ angles. The bevel head is available with any of our plasma options on the Torchmate 5100. This even includes the FlexCut 125 - one of the only bevel machines in the world that can use a conventional air plasma cutter. This presents an incredible opportunity to create beveled parts at a cost that is unmatched in the industry.

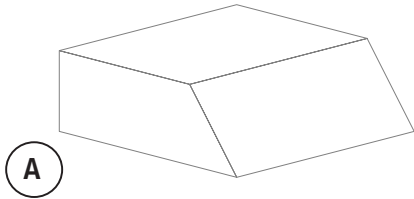
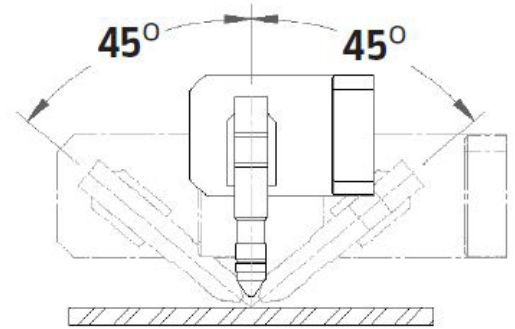

BEVEL KNIFE EDGE

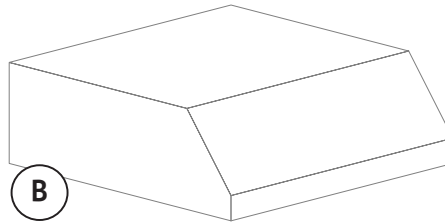

BEVEL KNIFE EDGE WITH LAND

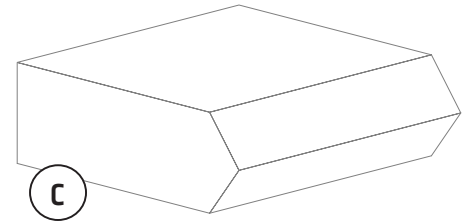

BEVEL K-CUT NO LAND

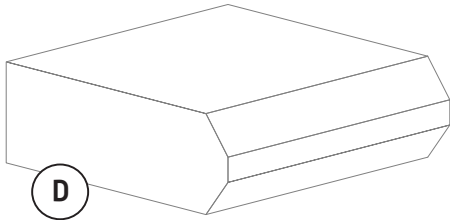

BEVEL K-CUT WITH LAND

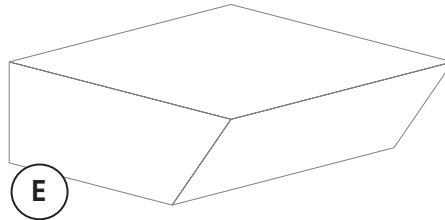

BEVEL UNDERCUT KNIFE EDGE

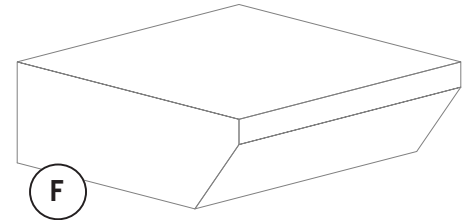

BEVEL UNDERCUT WITH LAND

	Image	3/8" [mm]	1/2" [mm]	5/8" [mm]	3/4" [mm]	7/8" [mm]	1" [mm]	1 1/4" [mm]	1 1/2" [mm]	1 3/4" [mm]	2" [mm]
--	-------	-------------	-------------	-------------	-------------	-------------	-----------	---------------	---------------	---------------	-----------

PRE-PROGRAMED BEVEL CUTS

Bevel Knife Edge	A	••	••	••	••	••	••	•			
Bevel Knife with Land	B		••	••	••	••	•	•			
Bevel K-Cut No Land	C		••	••	••	••	•	•			
Bevel K-Cut with Land	D			••	••	•	•	•			
Bevel Undercut Knife Edge	E	••	••	••	••	••	•	•			
Bevel Undercut With Land	F		••	••	••	••	••	•			

Dependent on COVID-19 restrictions - please call for details

ONLINE

Torchmate Academy Machine and CAD Training

Torchmate Academy is an online-based learning platform that takes the user guide's information to a new level. It covers all of the key features and functions in more detail.

Video walkthroughs and supporting documentation are provided throughout to assist you in getting the most out of your Torchmate investment.

<https://torchmate.com/academy>

- Basic Operations
- Visual Machine Designer Operation
- Maintenance and troubleshooting
- Plasma cutter and consumable overview
- Torchmate CAD Operations and Basic Training
- Importing and manipulating DXF files
- Nesting and layers
- Uses video, slides, and quizzes
- One year of access

ONSITE

Torchmate Onsite - Machine and CAD Training

Have our expert technicians come to your facility for 1-, 2-, or 3-day machine training and servicing at your facility. The provider will cover the machine operations, proper maintenance, and software training for a flat rate.

To get a updated cost and scheduling availability, email our team: LECSfieldservice@lincolnelectric.com

One Day

- Owner's Manual Review
- Verify all connections
- Verify factory specifications
- Perform factory acceptance test cut.
- Consumable Training
- Re-order information
- Plasma power supply operation

Second Day

- TMCAD overview and workflow
- Shape creation
- Text usage
- Tool path creation
- Cut path output
- Nameplate project
- Shape Library
- Job Set Up and Nesting
- Cut customer file
- Machine maintenance
- Acceptance sign off

Third Day

- Advanced CAD Training
- Working with Customer Files
- Additional hands-on Training



The previous scope of work defines the various options for CAD training, onsite machine commissioning, and operations training for the Torchmate 5100 table configurations. Please note that CAD training is not included in onsite machine commissioning and operations training options. Torchmate is not able to provide third-party CAD training. Any work outside the agreed scope will be billed separately for time and material via an approved Lincoln Electric Cutting Systems extra work order. Lincoln Electric Cutting Systems defines a workday as a typical 8 hour day with a 1-hour lunch break. Overtime hours requires approval.

Torchmate 5100 customer agrees to the following;

- Complete installation of Torchmate 5100 prior to Lincoln Electric Cutting Systems arrival on site.
- Network Components | Line in Place
- Test and training sample material on-site and ready for use (Please provide the size and type of plate you will cut.)
- Identify and make available, no more than 3 system operators for training.
- Completion of the following check off sheet provided to Lincoln Electric Cutting Systems in advance of visit.

1. ____ - Machine bed in operational location and leveled.
2. ____ - Confirm you have adequate, dry air pressure supplied for plasma at a constant 115 psi. minimum.
3. ____ - Plasma supply located and secured to the floor in an environmentally controlled room.
4. ____ - Connect all electrical cables to plasma power supply
5. ____ - AC power connected to Torchmate 5100
6. ____ - Oxy/Fuel hoses and plasma lead ran from the equipment to their supplies (if applicable).
7. ____ - Plasma power supply connections finished.
8. ____ - Grounding rods are placed and tested with ground cables connected to busbar.
9. ____ - Provide the appropriate Oxy/Fuel tips and gases for oxy/fuel & plasma cutting (if applicable).
(LECS supplies one Acetylene Oxy/Fuel tip size #1. Torch body provided is a Harris Model 98-6TAER-32 machine torch.)
10. ____ - If a water table unit provide suitable water source to table.
11. ____ - If downdraft table extraction unit connected to table and operational.
12. ____ - All required gases onsite with regulators. (Gas regulators are not included with Torchmate 5100)

- **The Lincoln Electric series of plasma power supplies for Torchmate 5100 machines all require 3 phase input.**
- **All systems must have time-delay fuses at the disconnect switch to handle the momentary influx of current when the system starts to cut. Please see the user guide for more information.**
- **The magnetic inrush current of the power supply will cause fast acting fuses to blow.**

Lincoln Electric Cutting System Sales Associate Name

Signature

TORCHMATE 5100 Customer Name

Signature

Lincoln Electric Cutting Systems Field Tech Name

Signature