



ALEDO ISD BOARD MEETING TEMPLATE

MEETING DATE: April 20, 2020

AGENDA ITEM: Consider Approval of Purchase of Cafeteria Serving Line at Stuard Elementary School

PRESENTER: Earl Husfeld, Chief Financial Officer and Patty Willhite, Director of Child Nutrition

BACKGROUND INFORMATION:

- Per Board Policy CH (Local), any single, budgeted purchase of goods or services that costs \$50,000 or more, regardless of whether the goods or services are competitively purchased, shall require Board approval before a transaction may take place.
- Staff in the Child Nutrition Department and Maintenance Department are recommending the replacement of the serving line/counter in the kitchen area at Stuard Elementary School.
- Due to the age of this equipment, the Maintenance Department is having extreme difficulty locating/buying replacement parts for the various equipment items (hot food wells, frost tops, etc.) comprising the serving line.
- Replacing the serving line with a new, updated line that is ergonomically efficient for students and staff is the best long-term value for the District.
- The design of the proposed serving line is based on the serving line installed at Walsh Elementary School.
- In conjunction with Lance Brooks, with Foodservice Design Professionals, the District solicited bids/quotes for this project. Three (3) responses were timely received that ranged in price from \$179,500.00 to \$180,911.00.
- After review of the bids/quotes received, and taking into consideration service and experience with this type of project, the recommendation is to accept the bid/quote received from Pasco Brokerage, Inc. in the amount \$180,911.00
- Subject to Board of Trustee approval, the new serving line will be installed during the summer.

FISCAL INFORMATION:

The cost of \$180,911.00 will be paid from available funds in Child Nutrition Fund 240.

ATTACHMENTS:

Schematic of Stuard Elementary School serving counter renovation and quote from Pasco Brokerage, Inc.

ADMINISTRATIVE RECOMMENDATION:

The Administration recommends the Board of Trustees approve the bid/quote received from Pasco Brokerage, Inc. for replacement of the cafeteria serving line at Stuard Elementary School as presented.



FOODSERVICE EQUIPMENT SCHEDULE			
FDP ITEM	QTY	FDP DESCRIPTION	FDP REMARKS
128	2	UTILITY CART	
186	2	PASS-THRU HEATED CABINET- 1DR	EXISTING
188	2	PASS-THRU REFRIGERATOR - 1DR	EXISTING
201	1	SERVING COUNTER	
209	2	DROP FRONT MILK COOLER - 8 CASE	
213	2	MOBILE ICE CREAM DISPENSER	
214	1	CASH REGISTER	OWNER FURNISHED
801	2	DROP-IN ICE CREAM	

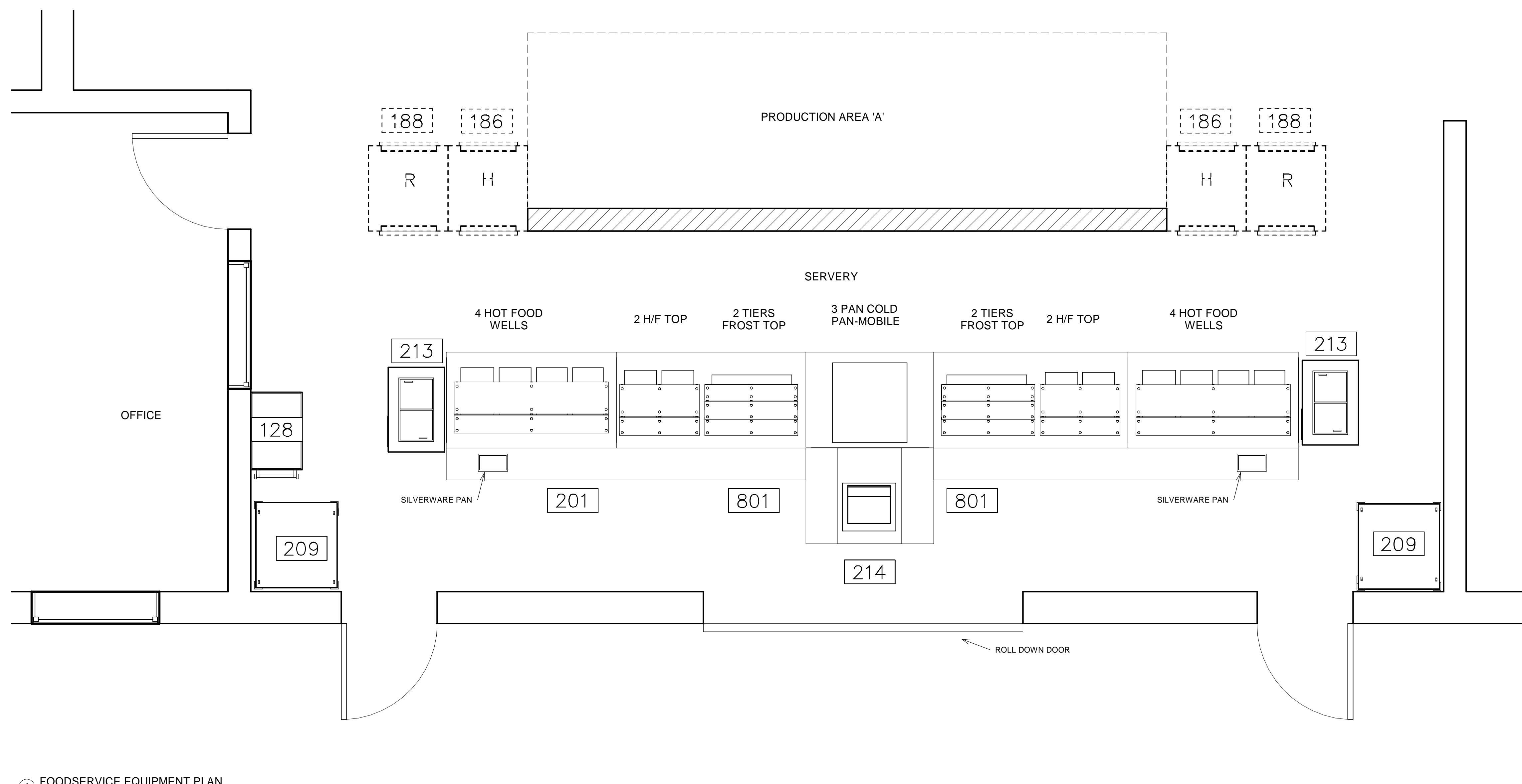

1 FOODSERVICE EQUIPMENT PLAN
1/2" = 1'-0"

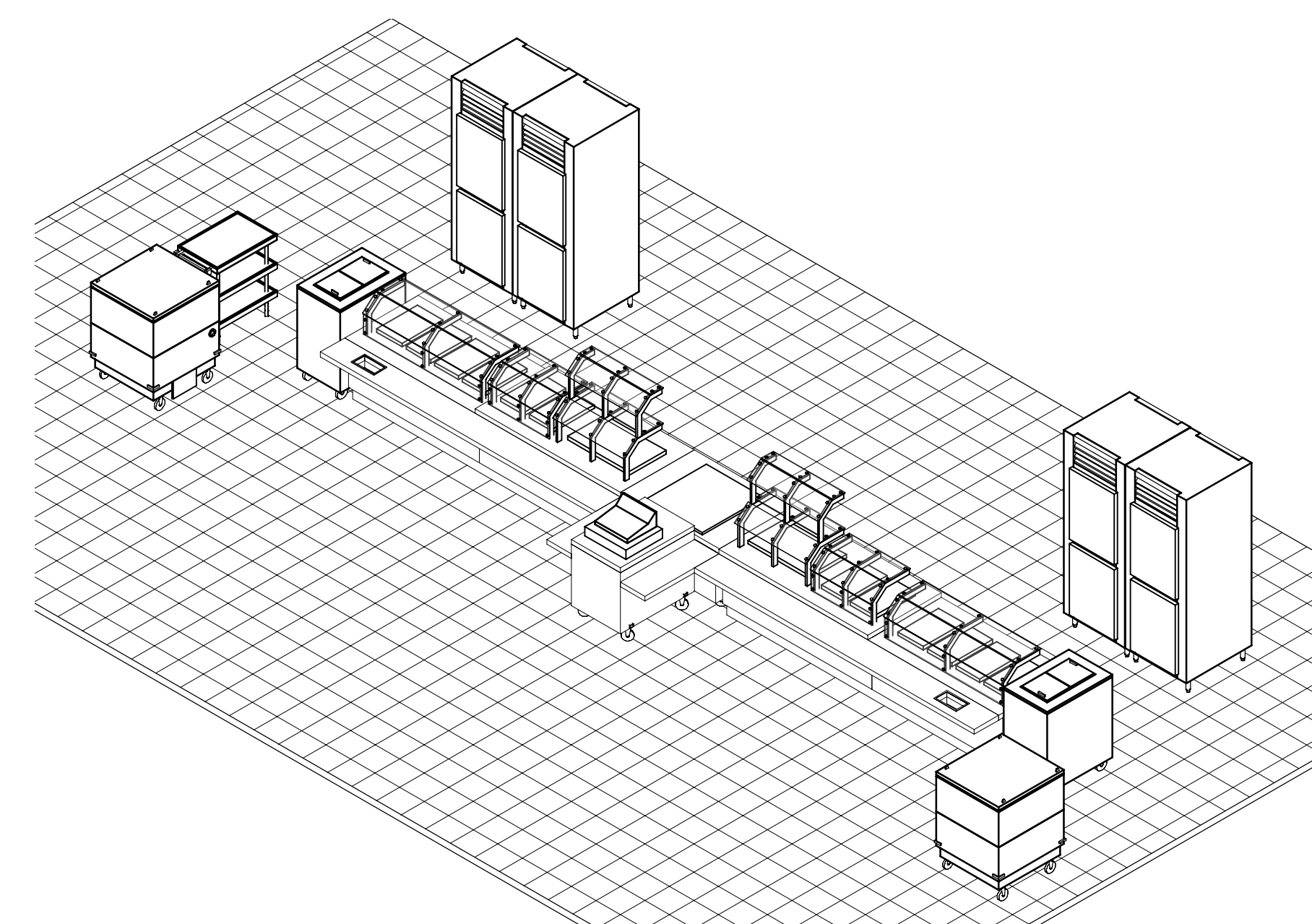

2 FS EQUIPMENT ONLY

**STUARD ES SERVING COUNTER
RENOVATION
ALEDO, TEXAS**

No.	Description	Date

**FS
EQUIPMENT
PLAN**

Project Number ---
Date ---
Drawn By ---
Checked By ---

K1

Scale 1/2" = 1'-0"





Quote

03/06/2020

To:
Aledo ISD
Patty Willhite

Project:
Aledo ISD Updated Quote for
Stuard Elementary School

From:
Pasco Brokerage Inc
Kasey Hollon
6465 Chase Oaks Blvd.
Plano, TX 75023-
(972) 596-3350
(972)596-3350 (Contact)

Customer ID: sd

PASCO's proposal is for Aledo ISD to disconnect existing serving line and move it to Aledo ISD's designated location (warehouse, surplus yard, etc.).

Please see the detailed proposal by CounterCraft. After CounterCraft sets in place, levels and makes necessary filed joints, Aledo ISD will make utility connections for the CounterCraft serving counter.

Pasco is a certified Texas HUB vendor, member number 063295, exp 01/22/2022.

Pasco is a certified Woman Owned Small Business, certificate number WOSB171585.

Item	Qty	Description	Sell	Sell Total
201ES	1 ea	CUSTOM ELEMENTARY SERVING COUNTER CounterCraft Model No. SCOL-300 see attachment	\$180,911.00	\$180,911.00
			ITEM TOTAL:	\$180,911.00
			Total	\$180,911.00

Acceptance: _____ Date: _____

Printed Name: _____

Project Grand Total: \$180,911.00



Item #	Qty	Price each	Price Total	Description
201	1	\$180911.	\$180911.	<p>Serving Counter CounterCraft Model No. SCOL-300</p> <ul style="list-style-type: none"> - Semi Closed base. Open on server side with undershelves where possible. No louvers required at front of counters. - 14 gauge stainless steel top, 2" turn down at free sides. - Countertop 34" high. - Laminate panel counter front. Color to be selected by architect / owner. Refer to drawings. - Solid surface (similar to Corian) trayslide with LED lights below. 1/4" stainless steel buttons and mounted at 32" above finished floor. Refer to drawings. - One (1) built-in s/s silverware pan located in trayslide. Refer to drawings. - One (1) lot CounterCraft adjustable series breath protector at hot food wells. Glass panels to be 3/8" tempered front and ends. Heat and LED lights as required.NSF compliant. - Provide two (2) Hatco model DHWBI-4 dry well series hot food wells. - Countertop at all hot food wells to be recessed to accommodate 18" X 26" sheet pan. - Two (2) each Hatco HCWBI-2DA hot cold food well with auto fill. - Two (2) each CounterCraft dual-tier GOVS with One (1) single-pan Frost only shelf located in counter body and One(1) single-pan frost only shelf located in breath guard; rotated 90 degrees. LED lights and Dekton inserts on both tiers. NSF compliant. Color to be confirmed with architect. - One (1) lot CounterCraft fixed dual-sided series breath protector at cold pan. Glass panels to be 3/8" tempered front and ends. LED lights as required.NSF compliant. - One (1) Hatco CWB-2 cold food pan. Refer to drawings. <p>NOTE: counter at cold pan and cashier counter to be separate, modular and on casters.</p> <ul style="list-style-type: none"> - One (1) lot Bon Chef tiles at hot, hot/cold and cold only food wells. Color to be selected by architect. - One (1) convenience outlet in each control panel. - Provide waterproof grommets in counter top for each piece of equipment mounted on counter top. - Provide integral cashier station with utility drawer mounted to the underside of the countertop. Cashier's section to be closed below with doors and removable intermediate shelves. Refer to elevations, sections and details. Provide D.C.O.'s, POS dedicated outlets below countertop. Coordinate final size with Owner's system. Verify cash or utility drawer with Owner. - 6" stainless steel adjustable legs. - 18 gauge stainless steel kick plate.
	1		INCLUDED	<p>CounterCraft Delivery and Onsite Assembly</p> <p>***NOTICE:*** CounterCraft pricing INCLUDES delivery and assembly. CounterCraft will deliver the quoted counter(s), uncrate, bring inside building, set in place, complete all field welds and joints, complete all final assembly, and level.</p> <p>This includes one (1) CounterCraft site visit for dimensioning and field coordination. If additional trips are required, additional charges may be incurred. Please request a quote.</p> <p>Final utility (plumbing / electrical) connections not by CounterCraft. Removal and disposal of existing equipment is not included.</p>

Total Quote Net \$180,911.00