

1 PARAPET FLASHING
 N.T.S.

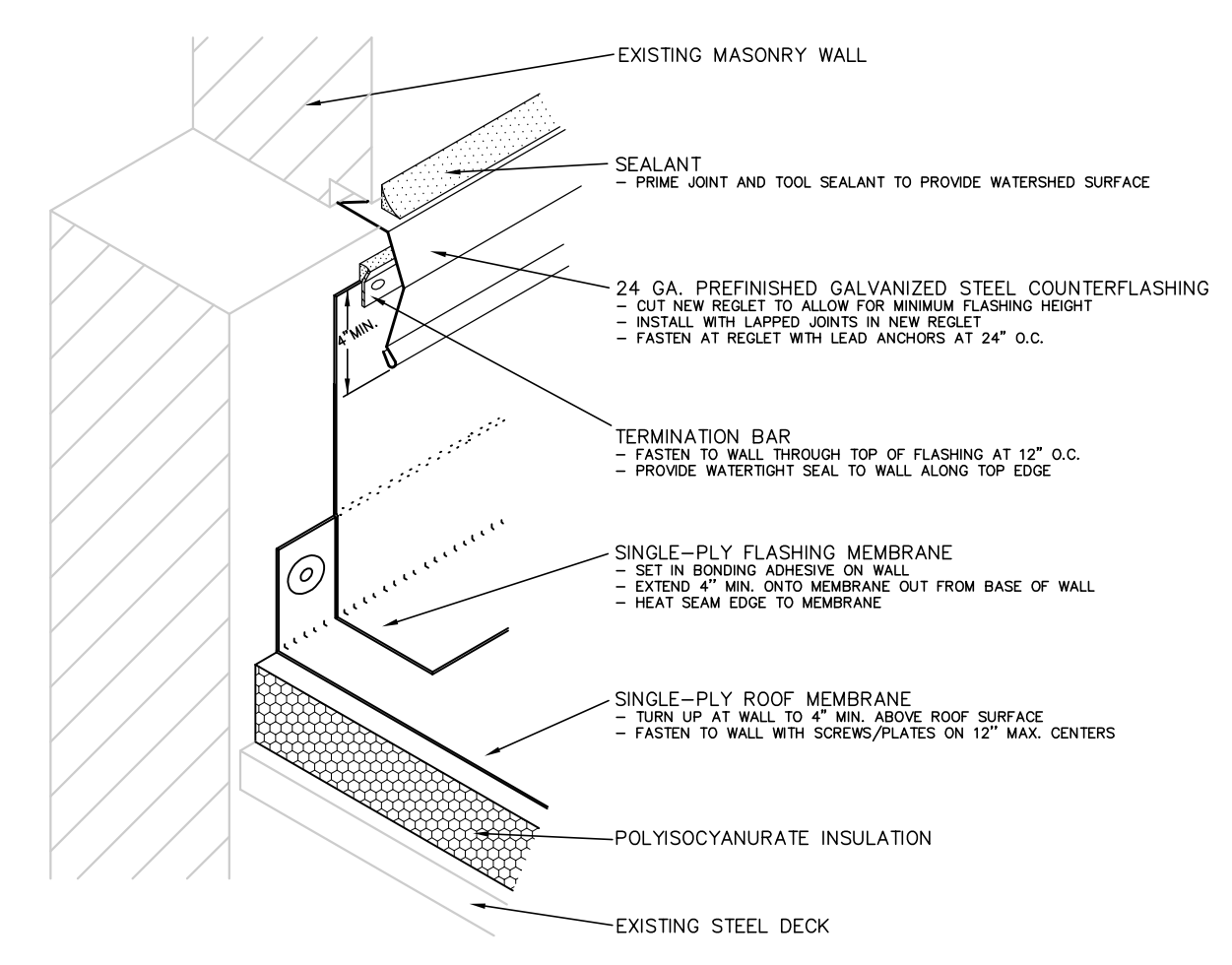

2 WALL FLASHING
 N.T.S.

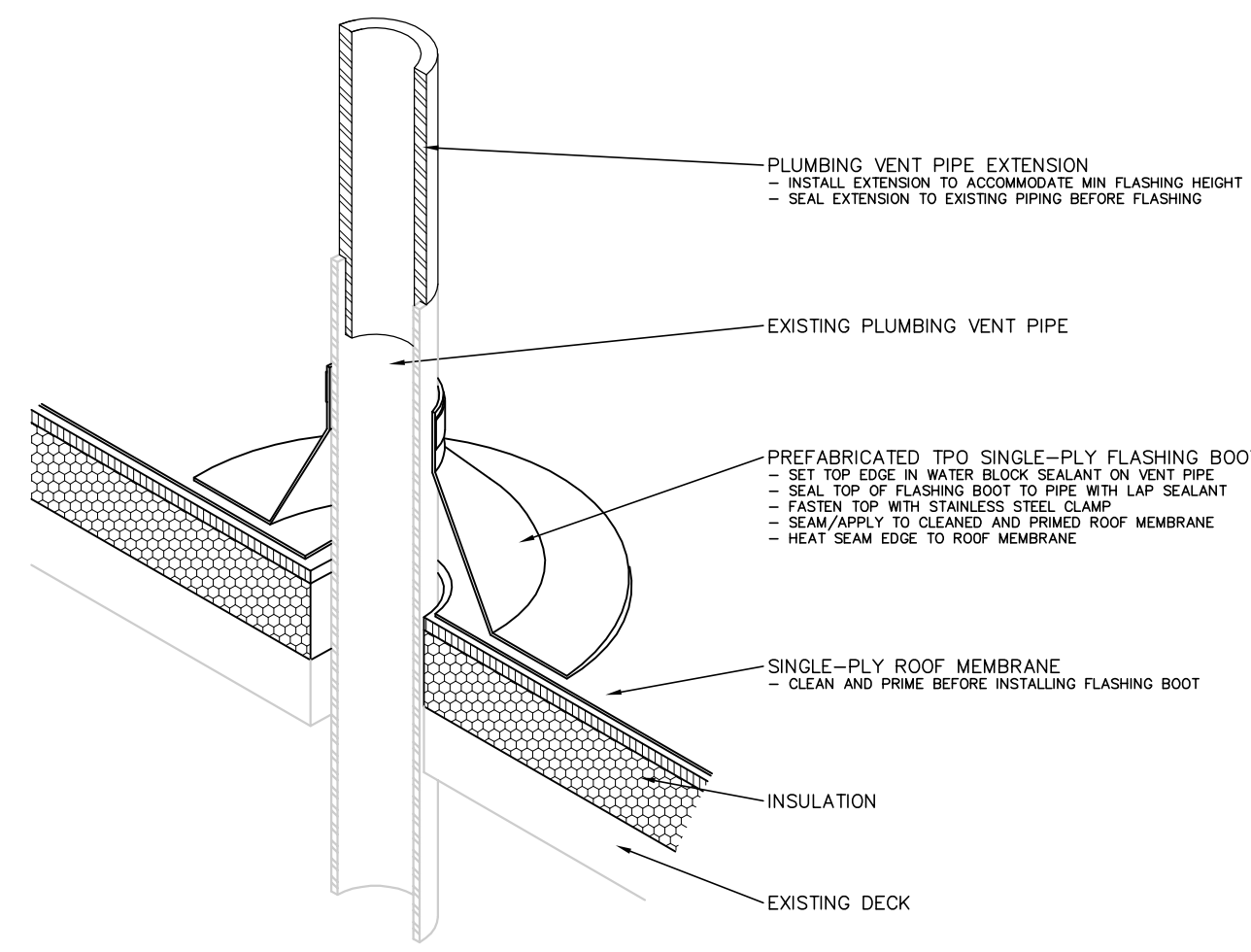

3 PLUMBING VENT WITH EXTENSION
 N.T.S.

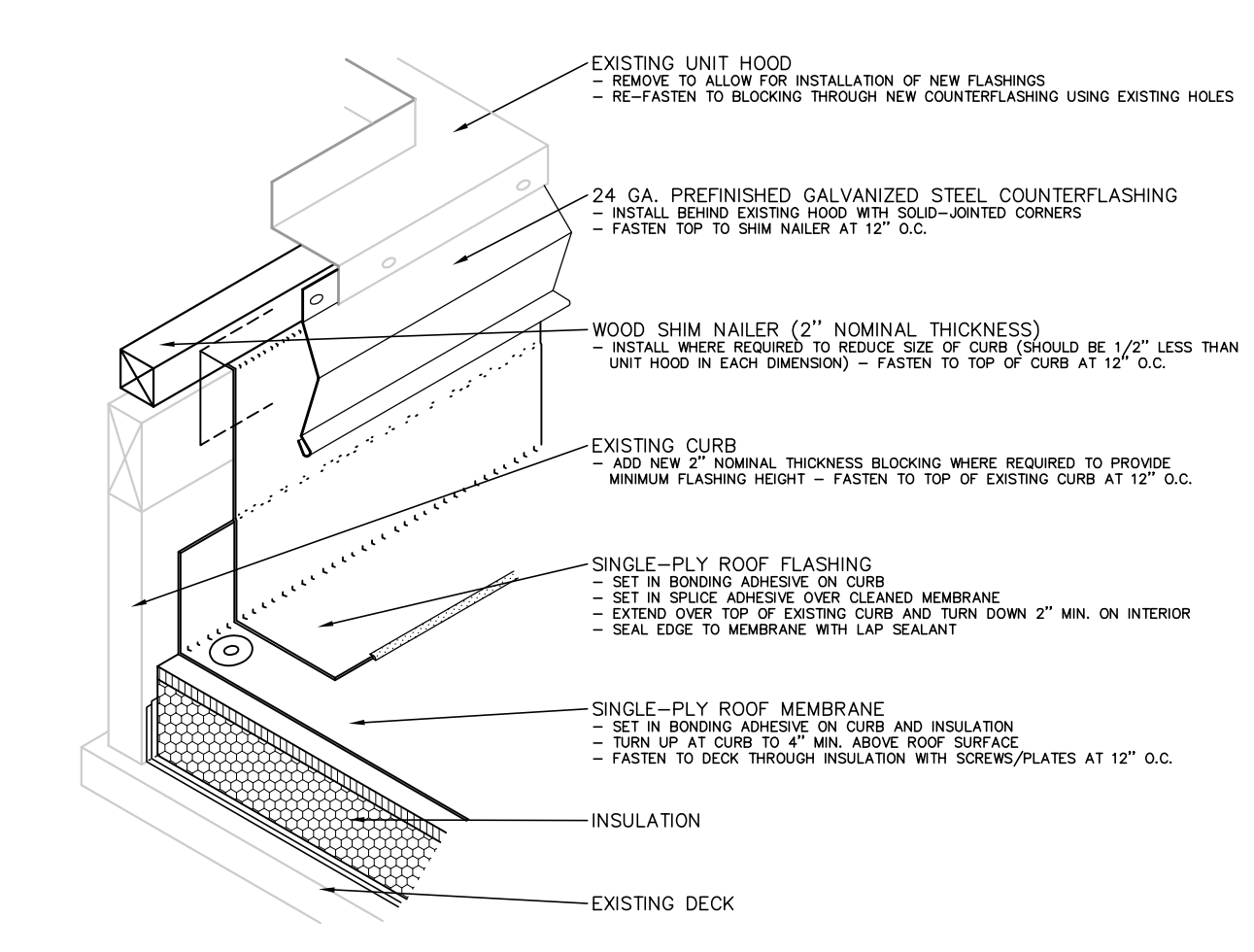

4 EXHAUST FAN CURB
 N.T.S.

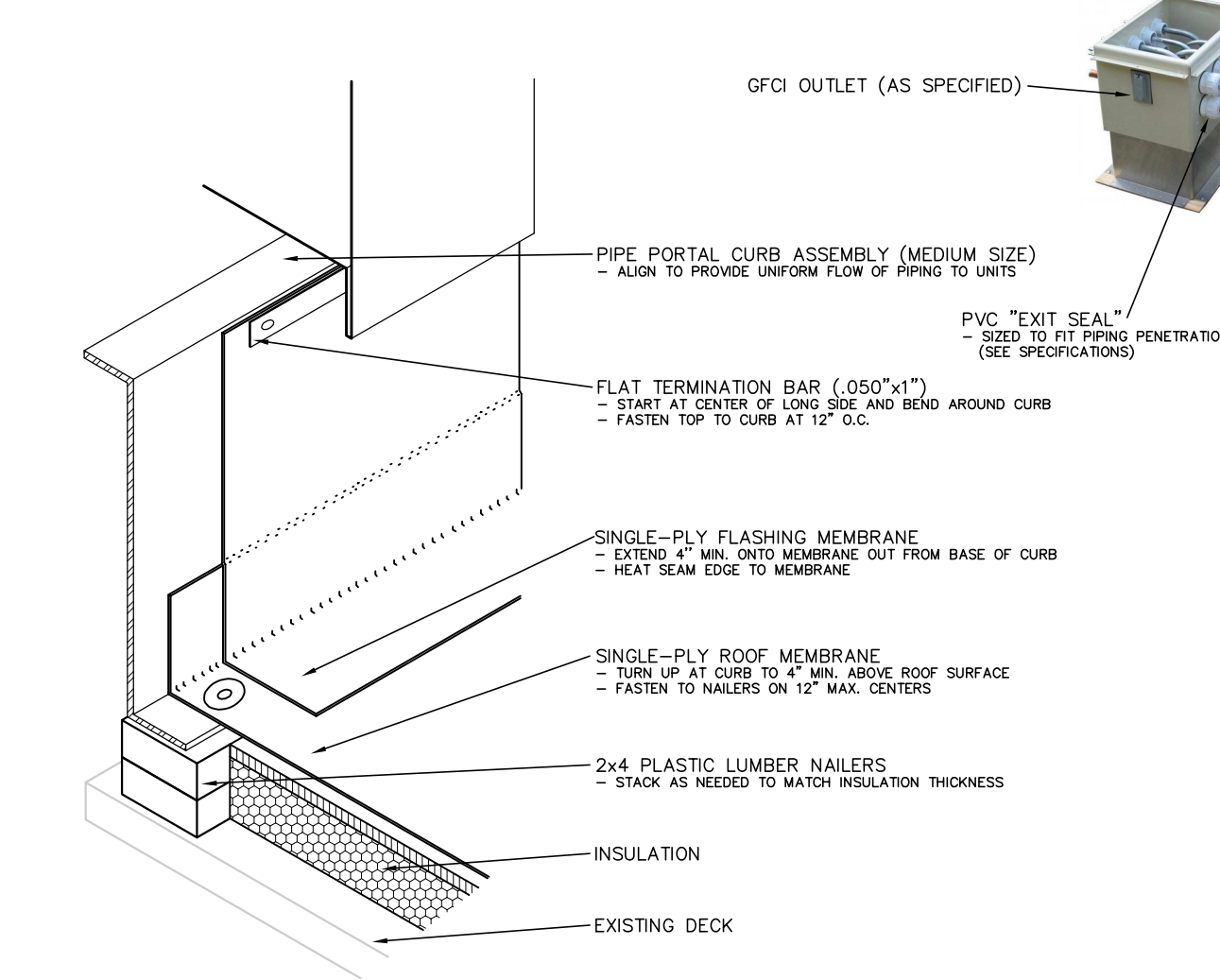

5 SMART BOX FLASHING
 N.T.S.

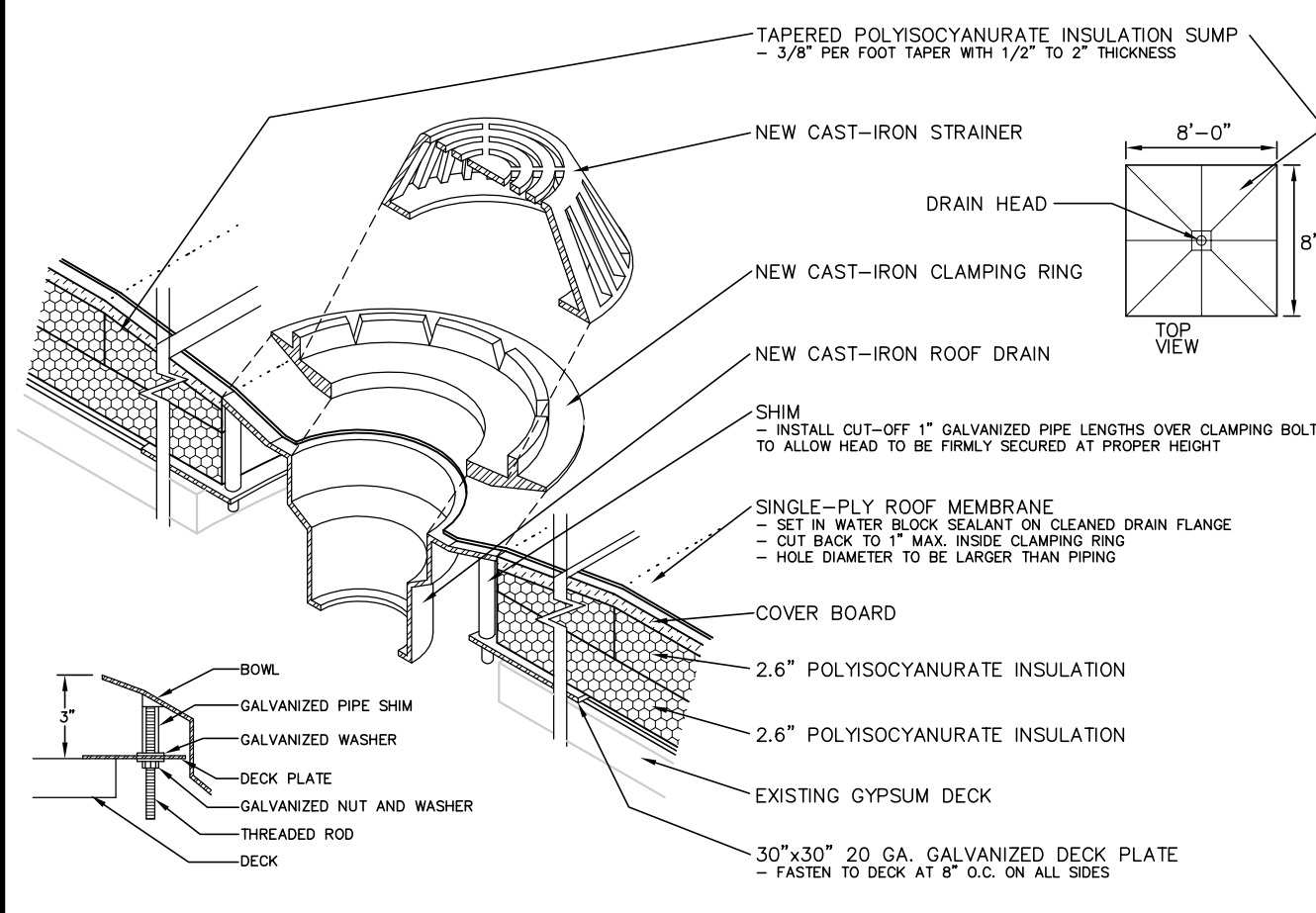

6 DRAINING FLASHING
 N.T.S.

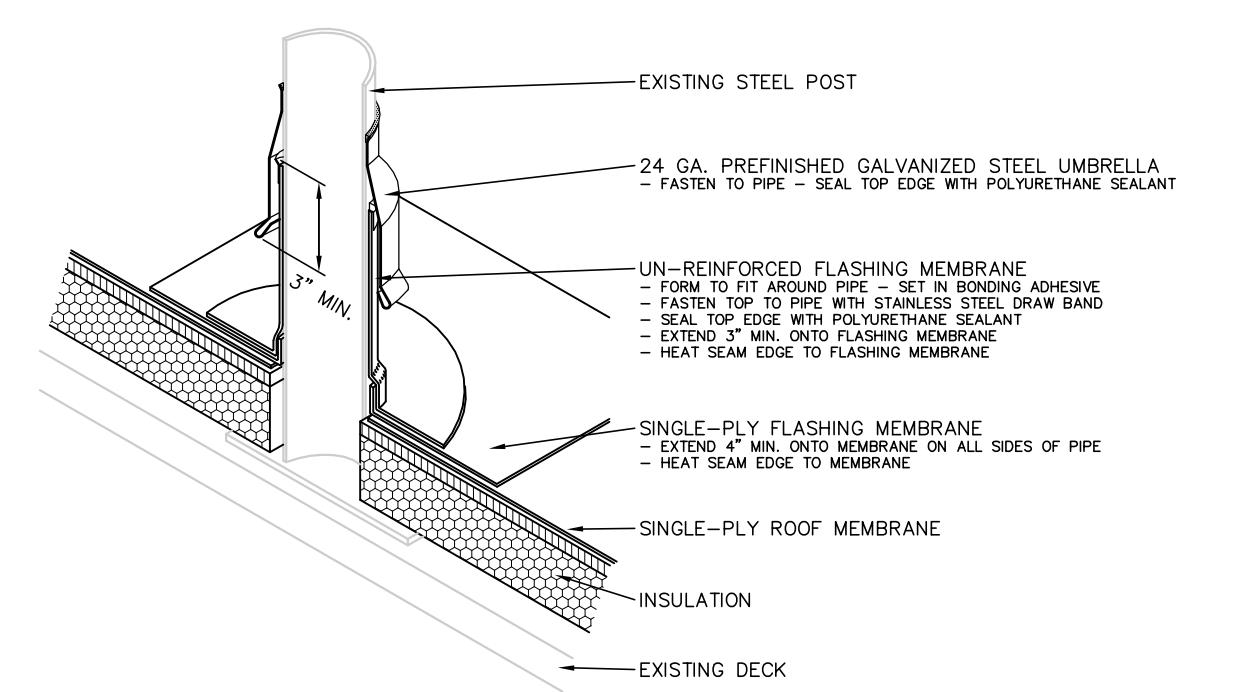

7 STEEL POST FLASHING
 N.T.S.

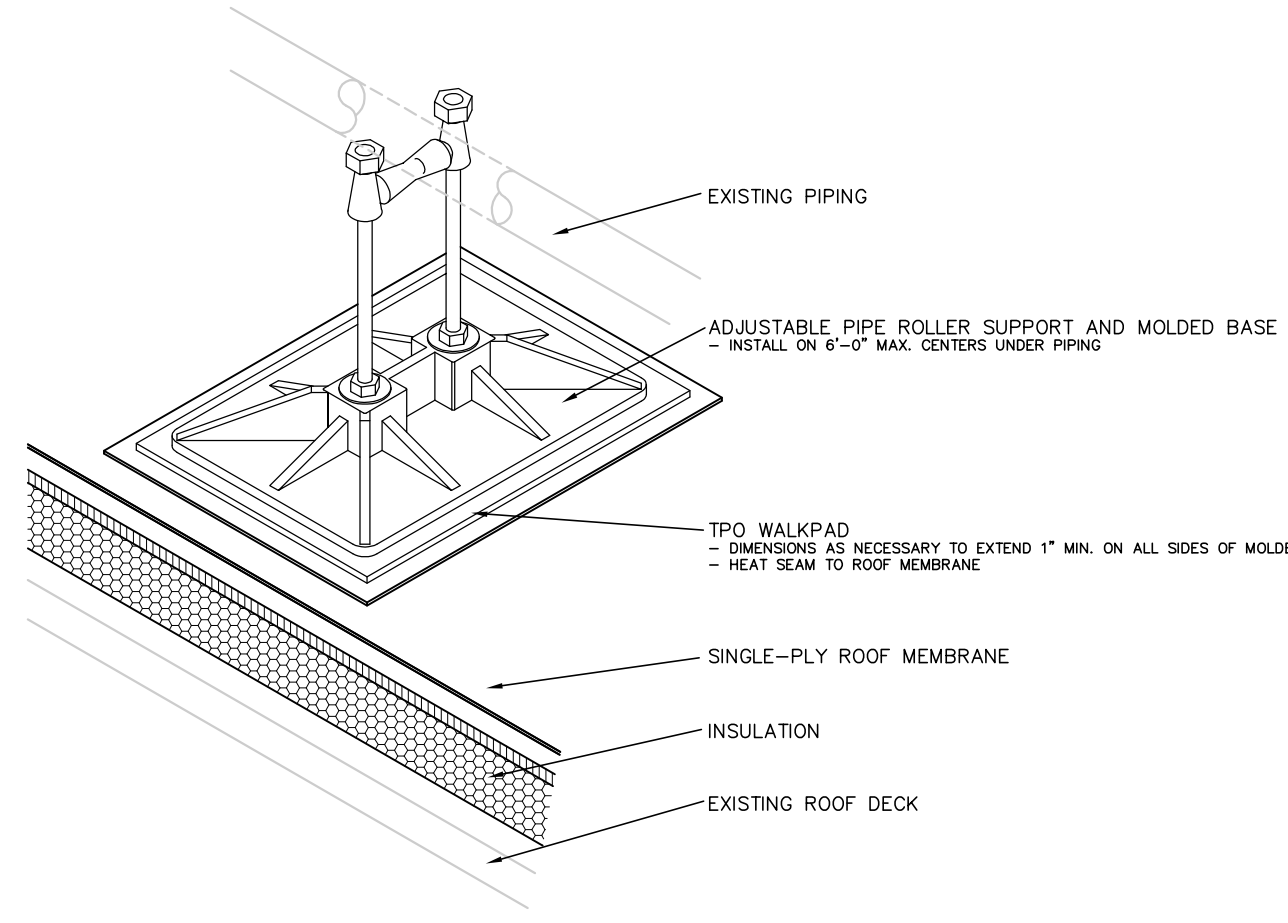

8 PIPE ROLLER SUPPORT
 N.T.S.

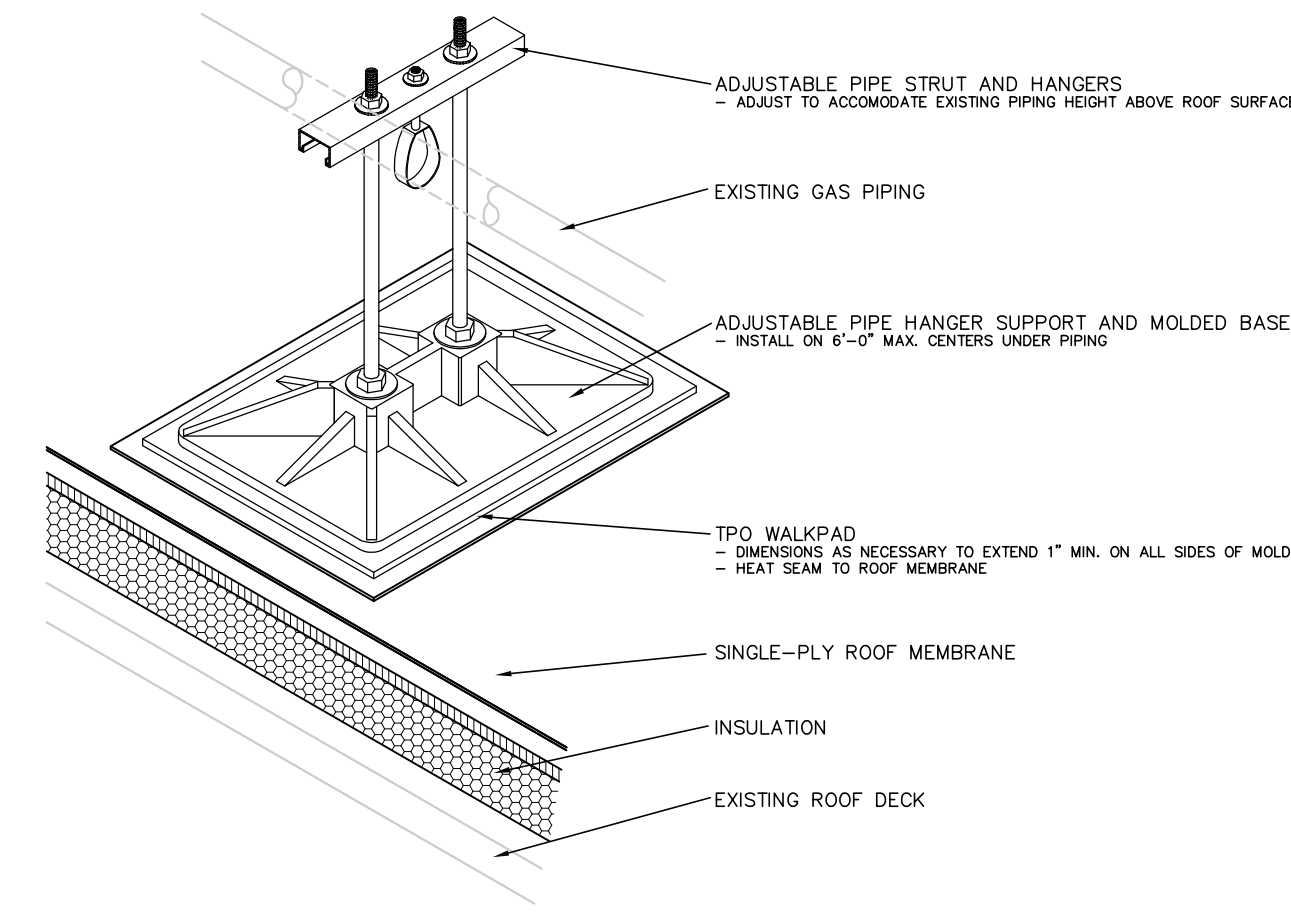

9 PIPE HANGER SUPPORT
 N.T.S.

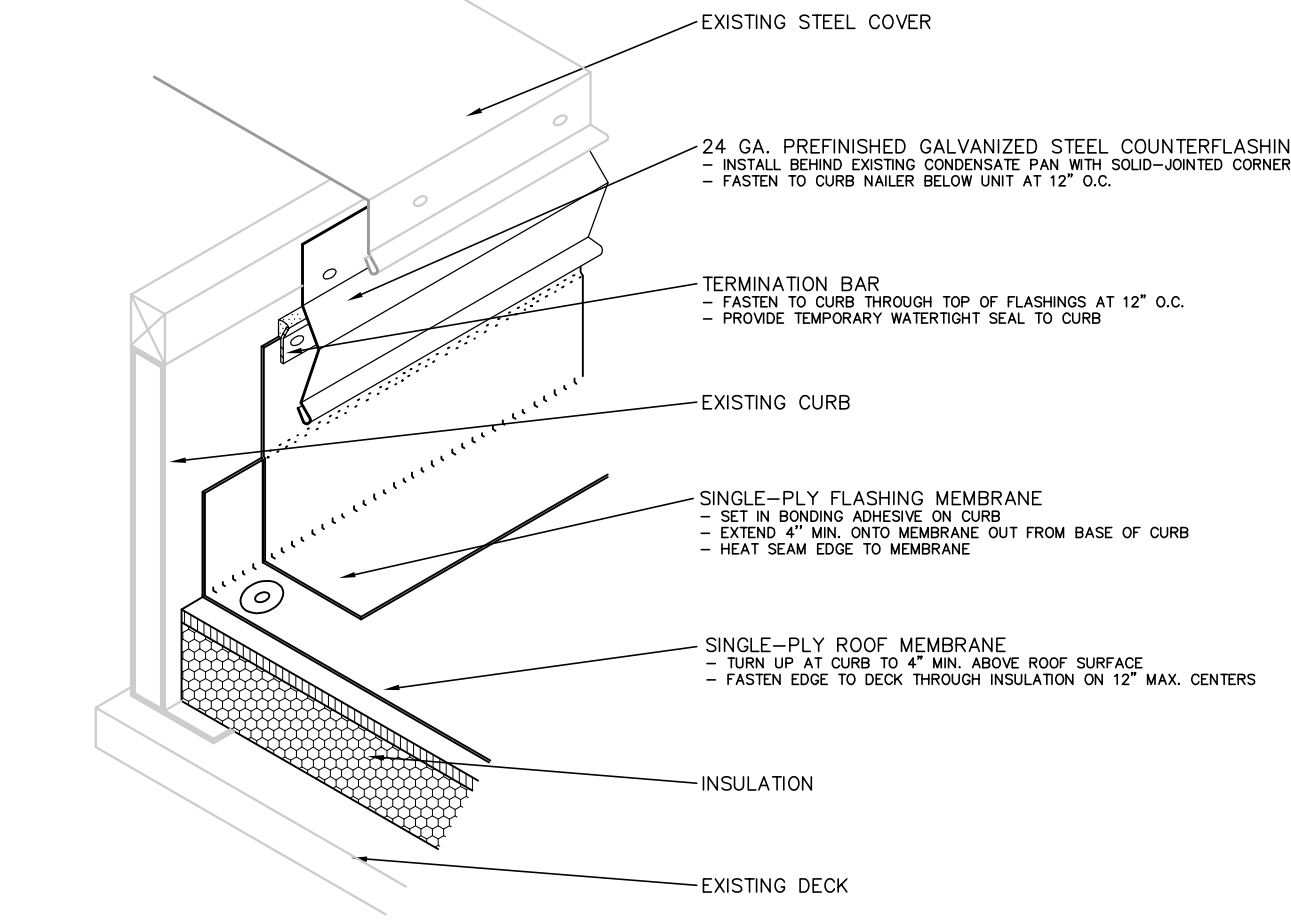

10 ROOF TOP UNIT CURB FLASHING
 N.T.S.

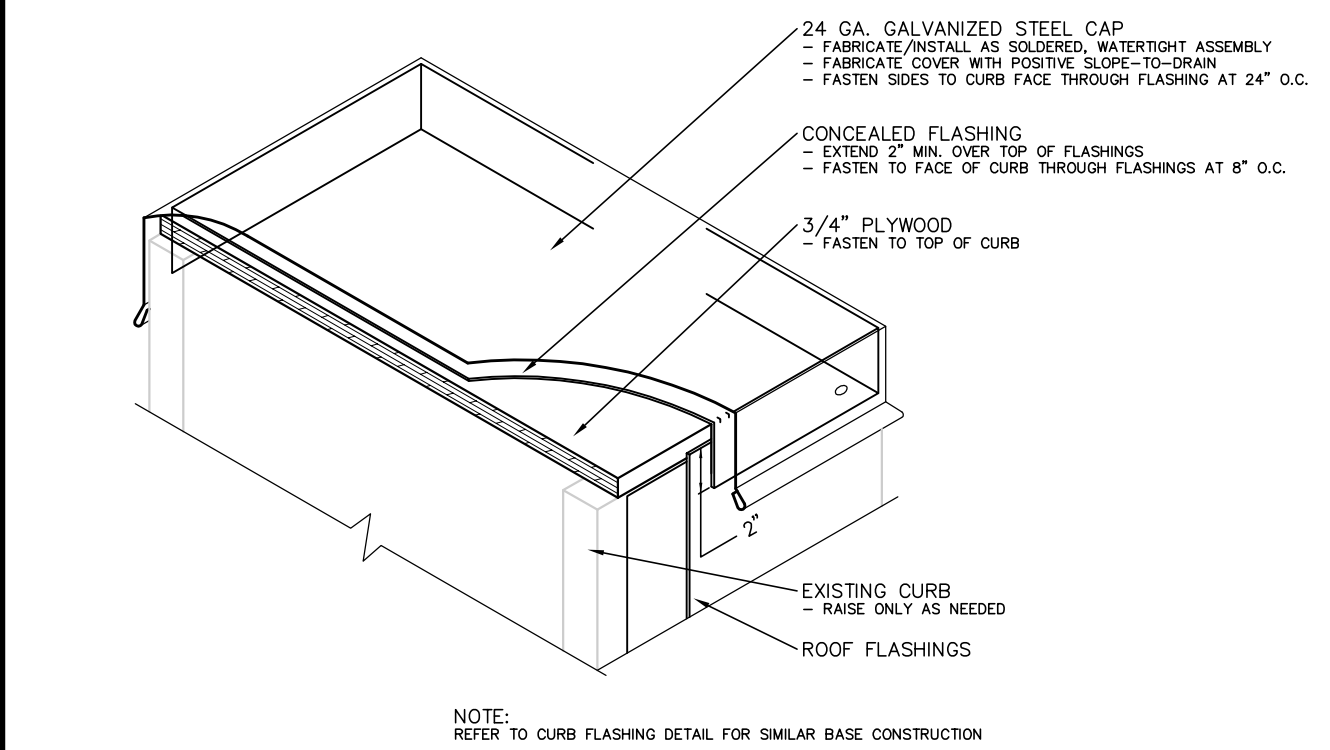

11 ABANDONED CURB FLASHING
 N.T.S.

KEY PLAN

SCOPE DOCUMENT
 This drawing is one drawing within a complete set of documents and shall not be considered separately from the Drawings as a whole. The Drawings indicate the general scope of the project in terms of architectural design, concept, the dimensions of the building, the major architectural elements and the type of structural, mechanical, and electrical systems. As Scope Documents, the Drawings do not necessarily indicate or describe all work required for full performance and completion of the requirements of the Construction Documents. On the basis of the general scope indicated or described, the Contractor shall furnish all items required for the proper execution and completion of the Work.

Copyright Notice, Copyright © 2017 STR PARTNERS LLC
 The information in this document is the intellectual property of STR Partners LLC. It is intended solely for use by the "Client" during only this specific project. Reproduction of any portion of this document for any purpose other than for its intended use is not permitted without specific written permission of STR Partners LLC.

PROJECT
2018 LIFE SAFETY WORK
 OAK PARK, IL 60302

IRVING ELEMENTARY SCHOOL
 1125 Cuyler Ave.
 Oak Park, IL 60304

OAK PARK ELEMENTARY SCHOOL DISTRICT 97
 280 W. Madison Street
 Oak Park, IL 60302

CLIENT PROJECT NUMBER

STR PROJECT NUMBER
17052

DRAWING DATES

NUMBER	DATE	COMMENTS
1	11/1/17	60% CD REVIEW
2	12/5/17	75% CD REVIEW
3	1/15/18	ISSUED FOR BID

DRAWING TITLE

Roof Details

SHEET NUMBER

IR.R1.1