

January 16, 2023

Mr. Phillip Francis  
Asst. Superintendent of District Services  
Livonia Public Schools  
15125 Farmington Road  
Livonia, MI 48154

RE: 2021 Bond Program  
LMC Furniture Purchase Recommendation  
LCTC/Robotics Addition & Renovations

Dear Mr. Francis:

This letter transmits an update from Plante Moran Cresa (PMC) as it relates to the assignment to assist and advise Livonia Public Schools (LPS) in its purchase of furniture for the Project listed above. This update represents the mutual efforts of PMC, TMP Architects, and LPS administration and staff (the Team).

Coinciding with the new LCTC/Robotics building addition and renovations, the Team has conducted multiple meetings and site visits over the course of the past few months focused on the selection of furniture to best serve the new spaces.

The Team recommends awarding the following contractors to supply and install furniture in an amount not-to-exceed **\$285,258.00** as further detailed below and within TMP's recommendation documents.

NBS Commercial Interiors:	\$	135,796.40
Interior Office Source	\$	76,510.62
DEW-EL	\$	3,836.14
Interior Environments	\$	39,373.53
Wenger	\$	16,157.59
<hr/>		
Sub-Total	\$	271,674.28
Contingency (5%)	\$	13,583.72
<hr/>		
<b>Total</b>	<b>\$</b>	<b>285,258.00</b>

For the Vendors, the pricing for this work will be detailed in Purchase Order Agreements, pending final review and approval of terms by district legal counsel.

The Team is available at the Board's convenience to answer any questions regarding this recommendation. Please direct all questions through me via email at [brian.weber@plantemoran.com](mailto:brian.weber@plantemoran.com).

Mr. Phil Francis  
Livonia Public Schools

January 16, 2023  
Page 2

Sincerely,

PLANTE MORAN CRESA

A handwritten signature in blue ink, appearing to read "Brian Weber", with a long horizontal flourish extending to the right.

Brian Weber  
Vice President

Enclosures:   TMP Recommendation Letter  
                  Vendor Proposals  
                  Product Information



January 18, 2023

Mr. Phillip Francis  
 Livonia Public Schools  
 15125 Farmington Rd.  
 Livonia, MI 48154

Re: Furnishing Recommendation  
 Livonia Career Technical Center and Robotics Addition  
 TMP Project No. 21036A

Dear Mr. Francis,

Quotations were received for the furniture for the Livonia Career Technical Center and Robotics Addition by multiple furniture contractors. Each furniture contractor has referenced the cooperative bid contract utilized to determine pricing within their quotes. The table below identifies each Category's associated costs, furniture manufacturer / contractor, and contract utilized. TMP recommends the procurement of furnishing packages as follows:

<u>MANUFACTURER CATEGORY</u>	<u>CONTRACT</u>	<u>AMOUNT</u>
<b><u>NBS Commercial Interiors</u></b>		
<b>Category A:</b> ERG International	TIPS	\$61,129.03
<b>Category B:</b> Steelcase	E&I	\$10,795.01
<b>Category C:</b> AMQ	E&I	\$29,410.32
<b>Category D:</b> Smith System	E&I	\$29,563.29
<b>Category L:</b> Safco	Omnia	\$4,898.75
<b><u>NBS COMMERCIAL INTERIORS TOTAL AWARD</u></b>		<b>\$135,796.40</b>
<b><u>Interior Office Source</u></b>		
<b>Category E:</b> KI	Sourcewell	\$28,613.12
<b>Category F:</b> WB Manufacturing	PEPPM	\$39,819.50
<b>Category H:</b> Fleetwood	NCPA	\$8,078.00
<b><u>INTERIOR OFFICE SOURCE TOTAL AWARD</u></b>		<b>\$76,510.62</b>
<b><u>DEW-EL</u></b>		
<b>Category G:</b> Media Technologies	NCPA	\$3,836.14
<b><u>DEW-EL TOTAL AWARD</u></b>		<b>\$3,836.14</b>
<b>Category I: Not Used</b>	---	---
<b><u>Interior Environments</u></b>		
<b>Category J:</b> Allsteel	Omnia	\$26,029.12
<b>Category K:</b> Watson	Omnia	\$13,344.41
<b><u>INTERIOR ENVIRONMENTS TOTAL AWARD</u></b>		<b>\$39,373.53</b>

Livonia Public Schools  
Furnishing Package  
TMP Project No.: 21036A  
Page No. 2

**Wenger**

**Category M: Wenger**

Omnia

\$16,157.59

**WENGER TOTAL AWARD**

**\$16,157.59**

**PACKAGE TOTAL AMOUNT: \$271,674.28**

Sincerely,

TMP ARCHITECTURE, INC.



Lauren Bush, Interior Designer

LEB/leb

Enclosure (Specifications, Quotes, and Furnishing Package Presentation)

**CATEGORY A:**

**ERG INTERNATIONAL**

Livonia CTC/Robotics Furnishings  
 Livonia Public School District  
 TMP Project No.: 21036A  
 1/12/2023

CATEGORY A: ERG International

Item	Total Qty	Manufacturer	Model No.	Location Qty	Description
<i>*(to include freight, delivery and installation)</i>					
A1	6	ERG International	8306		Raven Collection Size: 44" W Straight Unit (4 Legs) Overall Height: 33" High Fully Upholstered Back Flat Ganging Device for Soft Seating (GD2)
		<i>* Image for reference, not exact product.</i>			Finishes: Upholstery: CF Stinson Fuse 2.0 FSE 238 (Slate) Leg Color: Brushed Aluminum
				6	Location: Commons A101



Livonia CTC/Robotics Furnishings  
 Livonia Public School District  
 TMP Project No.: 21036A  
 1/12/2023

CATEGORY A: ERG International

Item	Total Qty	Manufacturer	Model No.	Location Qty	Description
A2	2	ERG International	8302		Raven Collection Size: 22" W Straight Unit (4 Legs) Overall Height: 33" High Fully Upholstered Back Flat Ganging Device for Soft Seating (GD2)  Finishes: Upholstery: CF Stinson Fuse 2.0 FSE 238 (Slate) Leg Color: Brushed Aluminum  Location: 2 Commons A101

*\* Image for reference, not exact product.*



Livonia CTC/Robotics Furnishings  
 Livonia Public School District  
 TMP Project No.: 21036A  
 1/12/2023

CATEGORY A: ERG International

Item	Total Qty	Manufacturer	Model No.	Location Qty	Description
A3	3	ERG International	8386		Raven Collection Size: Corner Unit - Square Seat (4 legs) Overall Height: 33" High Fully Upholstered Back Flat Ganging Device for Soft Seating (GD2)  Finishes: Upholstery: CF Stinson Fuse 2.0 FSE 238 (Slate) Leg Color: Brushed Aluminum  Location: 3 Commons A101
		* Image for reference, not exact product.			
					



Livonia CTC/Robotics Furnishings  
 Livonia Public School District  
 TMP Project No.: 21036A  
 1/12/2023

CATEGORY A: ERG International

Item	Total Qty	Manufacturer	Model No.	Location Qty	Description
------	-----------	--------------	-----------	--------------	-------------

A4	10	ERG International	CAP105		Capri Collection Almost Rectangle Top Rectangle Metal Base
----	----	-------------------	--------	--	--

*\* Image for reference, not exact product.*



Finishes:  
 High Pressure Laminate Top: Wilsonart,  
 Manitoba Maple, 7911-60  
 Base Color: Brushed Aluminum

6	Commons A101
4	Large Group Room B112

Livonia CTC/Robotics Furnishings  
 Livonia Public School District  
 TMP Project No.: 21036A  
 1/12/2023

CATEGORY A: ERG International

Item	Total Qty	Manufacturer	Model No.	Location Qty	Description
A5	1	ERG International	DUN24D		Duncan Occasional Round Size: 24" dia., 18" table height 4 Legs
					<i>* Image for reference, not exact product.</i>
					
					Finishes: High Pressure Laminate Top: Wilsonart, Manitoba Maple, 7911-60 Leg Color: Brushed Aluminum
				1	Location Commons A101

Livonia CTC/Robotics Furnishings  
 Livonia Public School District  
 TMP Project No.: 21036A  
 1/12/2023

CATEGORY A: ERG International

Item	Total Qty	Manufacturer	Model No.	Location Qty	Description	
A6	3	ERG International	8380		Raven Collection 48" W Back-to-Back Banquette Size: 48" Wide x 51.5" Deep x 33" High 6 Legs Two Fabric Option  Finishes: Seat Upholstery: CF Stinson Fuse 2.0, FSE 223 (Peacock) Back Upholstery: Designtex Big Dot, 3525-803 (Smoke) Leg Color: Brushed Aluminum	
		* Image for reference, not exact product.				
					3	Location Commons A110

Livonia CTC/Robotics Furnishings  
 Livonia Public School District  
 TMP Project No.: 21036A  
 1/12/2023

CATEGORY A: ERG International

Item	Total Qty	Manufacturer	Model No.	Location Qty	Description
A7	1	ERG International	8372		Raven Collection 48" W Straight Banquette Size: 48" Wide x 27" Deep x 33" High 4 Legs Two Fabric Option  Finishes: Seat Upholstery: CF Stinson Fuse 2.0, FSE 223 (Peacock) Back Upholstery: Designtex Big Dot, 3525-803 (Smoke) Leg Color: Brushed Aluminum
				1	Location Commons A110

*\* Image for reference, not exact product.*



Livonia CTC/Robotics Furnishings  
 Livonia Public School District  
 TMP Project No.: 21036A  
 1/12/2023

CATEGORY A: ERG International

Item	Total Qty	Manufacturer	Model No.	Location Qty	Description
A8	4	ERG International	MON42D		Monaco Collection Monaco Café Round Table Size: 42" dia., 29" Table Height 22" Base Spread  Finishes: High Pressure Laminate Top: Wilsonart, Manitoba Maple, 7911-60 Leg Color: Brushed Aluminum
				4	Location Commons A110

*\* Image for reference, not exact product.*



Livonia CTC/Robotics Furnishings  
 Livonia Public School District  
 TMP Project No.: 21036A  
 1/12/2023

CATEGORY A: ERG International

Item	Total Qty	Manufacturer	Model No.	Location Qty	Description
A9	4	ERG International	MON3048		<p>Monaco Collection            Monaco Café Rectangle Table            Size: 30" x 48" x 29" Table Height            2-17" Base Spread</p> <p>Finishes:            High Pressure Laminate Top: Wilsonart,            Manitoba Maple, 7911-60            Leg Color: Brushed Aluminum</p> <p>Location            Commons A110</p>
		* Image for reference, not exact product.		4	



Livonia CTC/Robotics Furnishings  
 Livonia Public School District  
 TMP Project No.: 21036A  
 1/12/2023

CATEGORY A: ERG International

Item	Total Qty	Manufacturer	Model No.	Location Qty	Description
A10	12	ERG International	DAK48D/CAS3/FLIPX		Dakota Collection Dakota Café Round Table Size: 48" Dia. X 29" High Table Base Spread: 38" - X With Casters, Black (CASD) Incline Nesting Legs (CIN) With Flip Top Mechanism  Finishes: High Pressure Laminate Top: Wilsonart, Manitoba Maple, 7911-60 Leg Color: Brushed Aluminum Caster Color: Black  Location 12 Large Group Room B112
		<i>* Image for reference, not exact product.</i>			
					

**CATEGORY B:**

**STEELCASE**



Livonia CTC/Robotics Furnishings  
 Livonia Public School District  
 TMP Project No.: 21036A  
 1/12/2023

CATEGORY B: Steelcase

Item	Total Qty	Manufacturer	Model No.	Location Qty	Description
------	-----------	--------------	-----------	--------------	-------------

*\*(to include freight, delivery and installation)*

B1	2	Steelcase	TS4TLP40		Steelcase Campfire Big Table with Grommets Size: 48" D x 96" W x 40" H with Modesty Panel Dual Power, TS4TPWRUSB
----	---	-----------	----------	--	---

*\* Image for reference, not exact product.*



Finishes:  
 High Pressure Laminate: Winter on Maple 2511  
 Modesty Panel: Winter on Maple 2511  
 Power: Arctic White, 7241

Location:  
 2 Commons A101

Livonia CTC/Robotics Furnishings  
 Livonia Public School District  
 TMP Project No.: 21036A  
 1/12/2023

CATEGORY B: Steelcase

Item	Total Qty	Manufacturer	Model No.	Location Qty	Description
B2	4	Steelcase	TS31401H		<p>Jenny Lounge, Armless            Fully upholstered lounge chair with tablet arm            With Glides            With Tablet Arm with 180 degree Swivel            with High Pressure Laminate Top</p> <p>Finishes:            Single Upholstery Fabric: CF Stinson, Fuse 2.0            FSE 241, Charcoal            Tablet Arm: High-Pressure Laminate            Winter on Maple 2511            Legs: Brushed Aluminum Legs</p> <p>Location            4 Commons A101</p>

*\* Image for reference, not exact product.*



**CATEGORY C:**

**AMQ**

Livonia CTC/Robotics Furnishings  
 Livonia Public School District  
 TMP Project No.: 21036A  
 1/12/2023

CATEGORY C: AMQ

Item	Total Qty	Manufacturer	Model No.	Location Qty	Description
------	-----------	--------------	-----------	--------------	-------------

*\*(to include freight, delivery and installation)*

C1	76	AMQ	BXBYARMLESS		Bixby Armless Stacking and Nesting Chair With Soft Casters
----	----	-----	-------------	--	---

*\* Image for reference, not exact product.*



Finishes:

Frame Color: Platinum

Plastic Seat Color: Platinum PC3

Plastic Backrest: Platinum PC3

Locations:

4 Conference Room A102

72 Large Group Room B112

Livonia CTC/Robotics Furnishings  
 Livonia Public School District  
 TMP Project No.: 21036A  
 1/12/2023

CATEGORY C: AMQ

Item	Total Qty	Manufacturer	Model No.	Location Qty	Description
------	-----------	--------------	-----------	--------------	-------------

C2	92	AMQ	BXBYARMLESS		Bixby Armless Stacking and Nesting Chair With Soft Casters
----	----	-----	-------------	--	---

*\* Image for reference, not exact product.*



Finishes:

Frame Color: Platinum

Plastic Seat Color: Wasabi PC6

Plastic Backrest: Wasabi PC6

Locations:

36	Flex Classroom A107
36	Flex Classroom A108
4	Robotics Field A116
16	Commons A110

**CATEGORY D:**

**SMITH SYSTEM**

Livonia CTC/Robotics Furnishings  
 Livonia Public School District  
 TMP Project No.: 21036A  
 1/12/2023

CATEGORY D: Smith System

Item	Total Qty	Manufacturer	Model No.	Location Qty	Description
------	-----------	--------------	-----------	--------------	-------------

*\*(to include freight, delivery and installation)*

D1      72      Smith System      1265

*\* Image for reference, not exact product.*



Planner Huddle - 6 Student  
 Size: 18" Deep x 30" Wide x 22'-32" High  
 Edge Type: 1 1/4in Top with 3mm Edge Band  
 with casters

Finishes:  
 High Pressure Laminate Top: Classic Linen 4943-38  
 Edge Finish: Champagne  
 Frame Finish: Platinum

Locations:  
 36 Flex Classroom A107  
 36 Flex Classroom A108

Livonia CTC/Robotics Furnishings  
 Livonia Public School District  
 TMP Project No.: 21036A  
 1/12/2023

CATEGORY D: Smith System

Item	Total Qty	Manufacturer	Model No.	Location Qty	Description
D2	2	Smith System	NL2560CLNPLTE		Elemental Adjustable Nest and Fold Table Size: 24" Deep x 60" Wide x 29"-40" High Edge Type: 1 1/4in Top with 3mm Edge Band with casters
					<i>* Image for reference, not exact product.</i>
					
					Finishes: High Pressure Laminate Top: Classic Linen 4943-38 Edge Finish: Champagne Frame Finish: Platinum Caster Finish: Platinum - PLT
				2	Locations: Robotics Field A116



Livonia CTC/Robotics Furnishings  
 Livonia Public School District  
 TMP Project No.: 21036A  
 1/12/2023

CATEGORY D: Smith System

Item	Total Qty	Manufacturer	Model No.	Location Qty	Description
D3	1	Smith System	EL3060EG		Elemental Rectangle Table Size: 30" Deep x 60" Wide x 30" High Edge Type: 1 1/4in Top with 3mm Edge Band
					<i>* Image for reference, not exact product.</i>
					
				1	Finishes: High Pressure Laminate Top: Classic Linen 4943-38 Edge Finish: Champagne Frame Finish: Platinum  Locations: Conference Room A102

**CATEGORY E:**

**KI**

Livonia CTC/Robotics Furnishings  
 Livonia Public School District  
 TMP Project No.: 21036A  
 1/12/2023

CATEGORY E: KI

Item	Total Qty	Manufacturer	Model No.	Location Qty	Description
------	-----------	--------------	-----------	--------------	-------------

*\*(to include freight, delivery and installation)*

E1	6	KI	DN4100H30FRPSKXGFT		Doni Café Stools Four-Leg Armless Café Stool 30" High Glide: Felt Glides (GFT)
					Finishes: Solid Color, Polypropylene: PSK Sky Blue Frame Color: SX Starlight Silver
				6	Location Commons A101

*\* Image for reference, not exact product.*



Livonia CTC/Robotics Furnishings  
 Livonia Public School District  
 TMP Project No.: 21036A  
 1/12/2023

CATEGORY E: KI

Item	Total Qty	Manufacturer	Model No.	Location Qty	Description
E2	12	KI	DN4100H30FRPZLSXGSL		Doni Café Stools Four-Leg Armless Café Stool 30" High Glide: Steel Glides (GSL)
					<i>* Image for reference, not exact product.</i>
					Finishes: Solid Color, Polypropylene: PZL Zesty Lime Frame Color: SX Starlight Silver
				12	Location Commons A101



Livonia CTC/Robotics Furnishings  
 Livonia Public School District  
 TMP Project No.: 21036A  
 1/12/2023

CATEGORY E: KI

Item	Total Qty	Manufacturer	Model No.	Location Qty	Description
------	-----------	--------------	-----------	--------------	-------------

E3	3	KI	RKT301841OP/36T		Ruckus Tote Storage Tall 2-Column Unit, Open with (10) 3" and (4) 6" Totes Totes included - translucent with no lid With Casters
----	---	----	-----------------	--	--

*\* Image for reference, not exact product.*



Finishes:  
 Shell Color: Sky Blue, SK

Locations:  
 3 Storage A105

Livonia CTC/Robotics Furnishings  
 Livonia Public School District  
 TMP Project No.: 21036A  
 1/12/2023

CATEGORY E: KI

Item	Total Qty	Manufacturer	Model No.	Location Qty	Description
E4	2	KI	RKT301841DR/36T		<p>Ruckus, Tote Storage, Tall, 2 Column unit with locking doors            Size: 30" Wide x 18" Deep x 40 3/4" High            Totes included - translucent with no lid (10) 3" and (4) 6" Totes            With Casters            All Lockable Storage Keyed Alike</p> <p>Finishes:            Shell Color: Sky Blue, SK            Beveled Pull - Satin Chrome</p> <p>Locations:            2 Robotics Field A116</p>

*\* Image for reference, not exact product.*



Livonia CTC/Robotics Furnishings  
 Livonia Public School District  
 TMP Project No.: 21036A  
 1/12/2023

CATEGORY E: KI

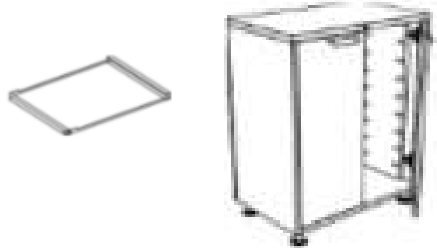
Item	Total Qty	Manufacturer	Model No.	Location Qty	Description
E5	3	KI	RKT301841DR/36T RKATSSHELF		<p>Ruckus, Tote Storage, Tall, 2 Column unit with locking doors            Size: 30" Wide x 18" Deep x 40 3/4" High            Empty - No totes included            With Casters            Ruckus Tote Storage Removable Steel Shelf with Rail Set            All Lockable Storage Keyed Alike</p> <p>Finishes:            Shell Color: Sky Blue, SK            Beveled Pull - Satin Chrome            Removable Shelf Color: Sky Blue, SK</p> <p>Locations:            3 Robotics Field A116</p>
			<p><i>* Image for reference, not exact product.</i></p>		
					

Livonia CTC/Robotics Furnishings  
 Livonia Public School District  
 TMP Project No.: 21036A  
 1/12/2023

CATEGORY E: KI

Item	Total Qty	Manufacturer	Model No.	Location Qty	Description
E6	2	KI	RKT301841DR/36T		<p>Ruckus, Tote Storage, Tall, 2 Column unit with locking doors            Size: 30" Wide x 18" Deep x 40 3/4" High            Empty - No totes included            With Casters            All Lockable Storage Keyed Alike</p> <p>Finishes:            Shell Color: Sky Blue, SK            Beveled Pull - Satin Chrome</p> <p>Locations:            2 Robotics Field A116</p>
					<p><i>* Image for reference, not exact product.</i></p> 



Livonia CTC/Robotics Furnishings  
 Livonia Public School District  
 TMP Project No.: 21036A  
 1/12/2023

CATEGORY E: KI

Item	Total Qty	Manufacturer	Model No.	Location Qty	Description
E7	3	KI	RKT301828OP/36T		<p>Ruckus Tote Storage, Short 2-Column Unit,            Open with (8) 3" and (2) 6" Totes            Size: 30" Wide x 18" Deep x 27 3/4" High            (8) 3" totes and (2) 6" totes            With Casters</p> <p>Finishes:            Shell Color: Sky Blue, SK</p> <p>Locations:            3 Robotics Studio A124</p>
		* Image for reference, not exact product.			
					

Livonia CTC/Robotics Furnishings  
 Livonia Public School District  
 TMP Project No.: 21036A  
 1/12/2023

CATEGORY E: KI

Item	Total Qty	Manufacturer	Model No.	Location Qty	Description
------	-----------	--------------	-----------	--------------	-------------

E8	3	KI	RKT301828OP/3T		Ruckus Tote Storage, Short 2-Column Unit, Open with (12) 3" Totes Size: 30" Wide x 18" Deep x 27 3/4" High With Casters
----	---	----	----------------	--	--

*\* Image for reference, not exact product.*



Finishes:  
 Shell Color: Sky Blue, SK

Locations:  
 3 Robotics Studio A117

Livonia CTC/Robotics Furnishings  
 Livonia Public School District  
 TMP Project No.: 21036A  
 1/12/2023

CATEGORY E: KI

Item	Total Qty	Manufacturer	Model No.	Location Qty	Description
------	-----------	--------------	-----------	--------------	-------------

E9	4	KI	RKT301828OP/3T		Ruckus Tote Storage, Short 2-Column Unit, Open with (6) 6" Totes Size: 30" Wide x 18" Deep x 27 3/4" High With Casters
----	---	----	----------------	--	---

*\* Image for reference, not exact product.*



Finishes:  
 Shell Color: Sky Blue, SK

Locations:  
 4 Robotics Studio A117

Livonia CTC/Robotics Furnishings  
 Livonia Public School District  
 TMP Project No.: 21036A  
 1/12/2023

CATEGORY E: KI

Item	Total Qty	Manufacturer	Model No.	Location Qty	Description
E10	50	KI	618WA		600 Series Industrial Stool Adjustable Height, 19"-27" High Self-leveling glides
					<i>* Image for reference, not exact product.</i>
					
					Finishes: Seat: Wood Frame Color: Warm Grey, WG
					Locations: 20 Robotics Studio A117 6 Robotics Studio A118 24 Robotics Studio A124

**CATEGORY F:**

**WB MANUFACTURING**

Livonia CTC/Robotics Furnishings  
 Livonia Public School District  
 TMP Project No.: 21036A  
 1/12/2023

CATEGORY F: WB Manufacturing

Item	Total Qty	Manufacturer	Model No.	Location Qty	Description
------	-----------	--------------	-----------	--------------	-------------

*\*(to include freight, delivery and installation)*

F1      10      WB Manufacturing      TOR9107

*\* Image for reference, not exact product.*



TORO Table with True Maple Top  
 Fully Welded 16-gauge 1" x 2" heavy duty steel apron  
 Size: 48" x 48"  
 Adjustable Legs: 1.5" square, steel tube -  
 22" - 38" overall height with nylon glides

Finishes:  
 Top: Maple Butcher Block 1.75" Thick Top  
 Legs: Smooth Silver (G4)  
 Frame: Smooth Silver (G4)

Location:  
 4      Robotics Studio A117  
 6      Robotics Studio A124

Livonia CTC/Robotics Furnishings  
 Livonia Public School District  
 TMP Project No.: 21036A  
 1/12/2023

CATEGORY F: WB Manufacturing

Item	Total Qty	Manufacturer	Model No.	Location Qty	Description
F2	7	WB Manufacturing	TOR9069		<p>TORO Table with True Maple Top            Fully Welded 16-gauge 1" x 2" heavy duty steel apron            Size: 24" x 48"            Adjustable Legs: 1.5" square, steel tube -            22" - 38" overall height with nylon glides            With Half Depth Shelf</p> <p>Finishes:            Top: Maple Butcher Block 1.75" Thick Top            Legs: Smooth Silver (G4)            Frame: Smooth Silver (G4)</p> <p>Location:            4 Robotics Studio A117            3 Robotics Studio A124</p>
					<p><i>* Image for reference, not exact product.</i></p> 

Livonia CTC/Robotics Furnishings  
 Livonia Public School District  
 TMP Project No.: 21036A  
 1/12/2023

CATEGORY F: WB Manufacturing

Item	Total Qty	Manufacturer	Model No.	Location Qty	Description
F3	2	WB Manufacturing	TOR9070		<p>TORO Table with True Maple Top            Fully Welded 16-gauge 1" x 2" heavy duty steel apron            Size: 24" x 54"            Adjustable Legs: 1.5" square, steel tube -            22" - 38" overall height with nylon glides</p> <p>Finishes:            Top: Maple Butcher Block 1.75" Thick Top            Legs: Smooth Silver (G4)            Frame: Smooth Silver (G4)</p> <p>Location:            2 Robotics Studio A117</p>
		<p><i>* Image for reference, not exact product.</i></p> 			



Livonia CTC/Robotics Furnishings  
 Livonia Public School District  
 TMP Project No.: 21036A  
 1/12/2023

CATEGORY F: WB Manufacturing

Item	Total Qty	Manufacturer	Model No.	Location Qty	Description
F4	4	WB Manufacturing	TOR9092		<p>TORO Table with True Maple Top            Fully Welded 16-gauge 1" x 2" heavy duty steel apron            Size: 36" x 60"            Adjustable Legs: 1.5" square, steel tube -            22" - 38" overall height with nylon glides            With Half Depth Shelf</p> <p>Finishes:            Top: Maple Butcher Block 1.75" Thick Top            Legs: Smooth Silver (G4)            Frame: Smooth Silver (G4)</p> <p>Location:            4 Robotics Studio A118</p>
		<p><i>* Image for reference, not exact product.</i></p> 			

**CATEGORY G:**

**MEDIA TECHNOLOGIES**

Livonia CTC/Robotics Furnishings  
 Livonia Public School District  
 TMP Project No.: 21036A  
 1/12/2023

CATEGORY G: Media Technologies

Item	Total Qty	Manufacturer	Model No.	Location Qty	Description
------	-----------	--------------	-----------	--------------	-------------

*\*(to include freight, delivery and installation)*

G1	2	Media Tech	CBLOX-17-17		Media Technologies Blox Seating Cylinder 17" Dia x 17" H High Density Foam Core
----	---	------------	-------------	--	---

*\* Image for reference, not exact product.*



Finishes:  
 Upholstery: Designtex Rise, Penny 3809-701

Location:  
 2 Commons A101

Livonia CTC/Robotics Furnishings  
 Livonia Public School District  
 TMP Project No.: 21036A  
 1/12/2023

CATEGORY G: Media Technologies

Item	Total Qty	Manufacturer	Model No.	Location Qty	Description
G2	2	Media Tech	CBLOX-17-17		Media Technologies Blox Seating Cylinder 17" Dia x 17" H High Density Foam Core
					<i>* Image for reference, not exact product.</i>
					Finishes: Upholstery: Designtex Rise, Grass 3809-502
				2	Location: Commons A101



Livonia CTC/Robotics Furnishings  
 Livonia Public School District  
 TMP Project No.: 21036A  
 1/12/2023

CATEGORY G: Media Technologies

Item	Total Qty	Manufacturer	Model No.	Location Qty	Description
G3	1	Media Tech	CBLOX-17-17		Media Technologies Blox Seating Cylinder 17" Dia x 17" H High Density Foam Core
					<i>* Image for reference, not exact product.</i>
					Finishes: Upholstery: Designtex Rise, Pool 3809-403
				1	Location: Commons A101



Livonia CTC/Robotics Furnishings  
 Livonia Public School District  
 TMP Project No.: 21036A  
 1/12/2023

CATEGORY G: Media Technologies

Item	Total Qty	Manufacturer	Model No.	Location Qty	Description
G4	2	Media Tech	CBLOX-17-17		Media Technologies Blox Seating Cylinder 17" Dia x 17" H High Density Foam Core
					<i>* Image for reference, not exact product.</i>
					Finishes: Upholstery: CF Stinson, La Scalina LAS 14 Flow
				2	Location: Commons A101



**CATEGORY H:**

**FLEETWOOD**

Livonia CTC/Robotics Furnishings  
 Livonia Public School District  
 TMP Project No.: 21036A  
 1/12/2023

CATEGORY H: Fleetwood Furniture

Item	Total Qty	Manufacturer	Model No.	Location Qty	Description
------	-----------	--------------	-----------	--------------	-------------

*\*(to include freight, delivery and installation)*

H1	3	Fleetwood	25RS640		Crank Height Adjustable Table Size: 60" Wide x 42" Depth Adjustable height with crank 2" diameter levelers - all legs 11.5" height adjustable legs Tubular base Metal Modesty Panel
----	---	-----------	---------	--	---

*\* Image for reference, not exact product.*



3	Finishes: Top: Solid Maple Block Base: Silver Paint  Locations: Robotics Studio A118
---	---



**CATEGORY I:**

**NOT USED**

**CATEGORY J:**

**ALLSTEEL**

Livonia CTC/Robotics Furnishings  
 Livonia Public School District  
 TMP Project No.: 21036A  
 1/12/2023

CATEGORY J: Allsteel

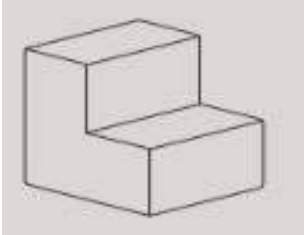
Item	Total Qty	Manufacturer	Model No.	Location Qty	Description
<i>*(to include freight, delivery and installation)</i>					
J1	5	Allsteel	S922S2		Allsteel Rise Rise 2-Tier Seating Dimensions: 34" H x 36" W x 40" D Non-Powered  Finishes: Upholstery: CF Stinson Fuse 2.0, FSE 238 (Slate)  Location: 5 Large Group Room B112
		* Image for reference, not exact product.			
					

Livonia CTC/Robotics Furnishings  
 Livonia Public School District  
 TMP Project No.: 21036A  
 1/12/2023

CATEGORY J: Allsteel

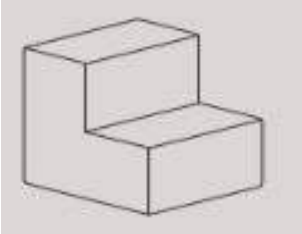
Item	Total Qty	Manufacturer	Model No.	Location Qty	Description	
J2	3	Allsteel	S922S2		Allsteel Rise Rise 2-Tier Seating Dimensions: 34" H x 36" W x 40" D Non-Powered  Finishes: Upholstery: CF Stinson Fuse 2.0, FSE 227 (Chive)  Location: 3 Large Group Room B112	
		* Image for reference, not exact product.				
						

Livonia CTC/Robotics Furnishings  
 Livonia Public School District  
 TMP Project No.: 21036A  
 1/12/2023

CATEGORY J: Allsteel

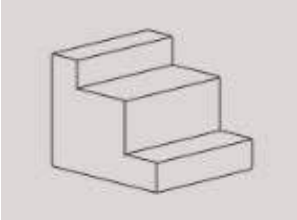
Item	Total Qty	Manufacturer	Model No.	Location Qty	Description
J3	1	Allsteel	S922S3		Allsteel Rise Rise 3-Tier Seating Dimensions: 34" H x 36" W x 40" D Non-Powered  Finishes: Upholstery: CF Stinson Fuse 2.0, FSE 227 (Chive)  Location: 1 Large Group Room B112
		* Image for reference, not exact product.			
					

Livonia CTC/Robotics Furnishings  
 Livonia Public School District  
 TMP Project No.: 21036A  
 1/12/2023

CATEGORY J: Allsteel

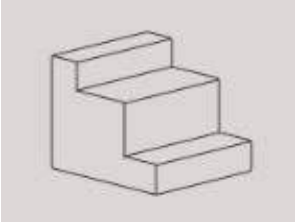
Item	Total Qty	Manufacturer	Model No.	Location Qty	Description	
J4	1	Allsteel	S922S3		Allsteel Rise Rise 3-Tier Seating Dimensions: 34" H x 36" W x 40" D Non-Powered  Finishes: Upholstery: CF Stinson Fuse 2.0, FSE 223 Peacock)  Location: 2 Large Group Room B112	
		* Image for reference, not exact product.				
						

Livonia CTC/Robotics Furnishings  
 Livonia Public School District  
 TMP Project No.: 21036A  
 1/12/2023

CATEGORY J: Allsteel

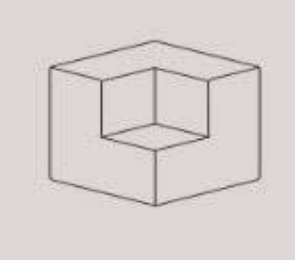
Item	Total Qty	Manufacturer	Model No.	Location Qty	Description
J5	2	Allsteel	S922S21C		Allsteel Rise Rise 2-Tier Inside Corner Dimensions: 34" H x 40" W x 40" D
					<i>* Image for reference, not exact product.</i>
					
					Finishes: Upholstery: CF Stinson Fuse 2.0, FSE 223 Peacock)
				2	Location: Large Group Room B112

**CATEGORY K:**

**WATSON**



Livonia CTC/Robotics Furnishings  
 Livonia Public School District  
 TMP Project No.: 21036A  
 1/12/2023

CATEGORY K: Watson

Item	Total Qty	Manufacturer	Model No.	Location Qty	Description
------	-----------	--------------	-----------	--------------	-------------

*\*(to include freight, delivery and installation)*

K1      11      Watson Furniture    WEM204660

*\* Image for reference, not exact product.*



Etch Mobile Markerboard  
 Size: 46" Wide x 20" Deep x 60" High  
 with casters and Marker Cloth

Finishes:  
 Powdercoat Finish: Sapphire, SAP

- Locations:
- 2    Commons A101
  - 6    Robotics Studio A124
  - 1    Commons A110
  - 2    Large Group Room B112

Livonia CTC/Robotics Furnishings  
 Livonia Public School District  
 TMP Project No.: 21036A  
 1/12/2023

CATEGORY K: Watson

Item	Total Qty	Manufacturer	Model No.	Location Qty	Description
K2	11	Watson Furniture	WEMC020304		Etch Magnetic Marker Cup Accessory Size: 3" Wide x 4" High x 2" Deep
					<i>* Image for reference, not exact product.</i>
					
					Finishes: Manufacturer's Standard Finish
					Locations: 2 Commons A101 6 Robotics Studio A124 1 Commons A110 2 Large Group Room

**CATEGORY L:**

**SAFCO**

Livonia CTC/Robotics Furnishings  
 Livonia Public School District  
 TMP Project No.: 21036A  
 1/12/2023

CATEGORY L: Safco

Item	Total Qty	Manufacturer	Model No.	Location Qty	Description
------	-----------	--------------	-----------	--------------	-------------

*\*(to include freight, delivery and installation)*

L1	5	Safco	6244BL		Safco Boltless Steel and Particleboard Shelving Wood Deck with 5 Shelves Size: 48" W x 24" D x 72" H
----	---	-------	--------	--	--

*\* Image for reference, not exact product.*



Finishes:  
 Metal: Black  
 Shelves: Natural Wood

- Locations:
- 2 Robotics Studio Storage A119
  - 3 Storage A105

Livonia CTC/Robotics Furnishings  
 Livonia Public School District  
 TMP Project No.: 21036A  
 1/12/2023

CATEGORY L: Safco

Item	Total Qty	Manufacturer	Model No.	Location Qty	Description
------	-----------	--------------	-----------	--------------	-------------

L2	9	Safco	6247BL		Safco Boltless Steel and Particleboard Shelving Wood Deck with 5 Shelves Size: 36" W x 24" D x 72" H
----	---	-------	--------	--	--

*\* Image for reference, not exact product.*



Finishes:  
 Metal: Black  
 Shelves: Natural Wood

- Locations:
- 3 Storage A121
  - 3 Storage A122
  - 3 Storage A123

**CATEGORY M:**

**WENGER**

Livonia CTC/Robotics Furnishings  
 Livonia Public School District  
 TMP Project No.: 21036A  
 1/12/2023

CATEGORY M: Wenger

Item	Total Qty	Manufacturer	Model No.	Location Qty	Description
------	-----------	--------------	-----------	--------------	-------------

\*(to include freight, delivery and installation)

M1      1      Wenger      CUSTOM

*\* Image for reference, not exact product.*

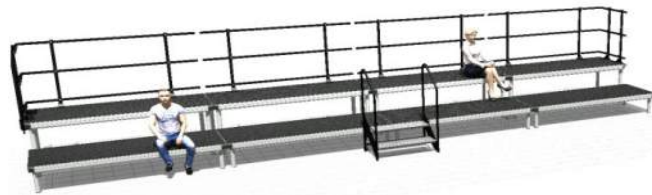

Wenger StageTek Audience Seating  
 Based on Quote No. 3262777  
 Overall Dimensions: 32'-0" x 6'-0"  
 (8) StageTek Rectangular Deck 3'x8'  
 (16) StageTek Fixed Leg 32" Elevation  
 (32) StageTek Fixed Leg 16" Elevation  
 (14) StageTek Connect, 2 Leg Rectangular  
 (12) Leg Storage Clip, 4 pk  
 (4) StageTek Standard Guardrail 8'  
 (2) StageTek Standard Guardrail 3'  
 (8) Leg Straps, 45", 2 pk  
 (1) StageTek 2-Step Stairway 16/24" with Rail  
 (3) Staging Universal Deck and Rail Cart

Finishes:  
 Rectangular Desk: Cracked Ice, Black  
 Metal Finish: Black

Location:  
 1      Robotics Field A116



2595 Bellingham • Troy, MI 48083 • 248.823.5400 • 248.823.5401 Fax  
 2211 Old Earhart Rd. Ste.190 • Ann Arbor, MI 48105 • 248.823.5400 • 248.823.5401 Fax  
 3201 Pine Tree Rd. Ste. A • Lansing, MI 48911 • 517.886.0072 • 248.823.5401 Fax  
 5160 Alliance Dr. • Bay City, MI 48706 • 989.895.8574 • 989.895.8545 Fax  
 4 North St. Clair St. • Toledo, OH 43604 • 419.662.2040 • 248.823.5401 Fax

**Quotation 357940**

**Quote Date** 01/09/23  
**Customer Order**  
**Project** 222305  
**Customer** L00002  
**Terms** NET 10 DAYS  
**Expiration Date**  
**Account Representative** ANNE MARIE TREMBERTH (HCT)

**yourNBS.com**      **Remit Payments to:** NBS, 6973 Reliable Parkway, Chicago, IL 60686

**Quote To**

Livonia Public Schools  
 15125 FARMINGTON RD  
 LIVONIA, MI, 48154-5413

**Ship To**

Lauren Bush  
 Livonia Career Technical Center  
 8985 Newburgh Rd  
 Livonia, MI, 48150

**Phone** +1 (313) 523-9156  
**Fax** +1 (734) 421-4870

**Phone** +1 (248) 338-4561

Lbush@tmp-architecture.com

**Sales Location** Troy

**Target install dates: 7.31.23 - 8.11.23**  
**3-4 days needed for NBS install**

**Following contracts utilized for pricing on this quote:**

**E&I Contract: STC, AMQ, Smith System**

**Omnia: Safco**

**TIPS + Add'l project discounting: ERG**

**School is responsible for contract membership enrollment. Changes to specifications and quantity could affect tiered contract pricing.**

**Pricing valid for 30 days.**

**Please verify finish selections prior to order placement.**

**If due to unforeseen circumstances the building is not ready to receive furniture, additional fees may be incurred to double handle and/or store the furniture. Circumstances include, but are not limited to construction delays and COVID-19.**

**Storage Free for 30 days, after which storage is charged per SF per month.**

**Quote includes Non-Union labor for NBS to receive, deliver and install during Normal Business Hours; any owner requested changes requiring additional delivery trip(s) will result in additional charges to be quoted separately.**

**Overtime Labor (evening after hours and weekends) additional.**

**Purchase Order and 40% Deposit is required before order placement; please reference NBS quote number on PO. Receipt of PO indicates owner approval of product as specified; upon release of order, no changes, cancellations or returns can be made.**

**\*NOTE: DEPOSIT WAIVED FOR LPS**

**Thank you!**

\*\*\*\*\*

**Lead time: 14-16 weeks**

TITLE OF PRODUCT TRANSFERS UPON RECEIPT BY CUSTOMER.

ACCEPTED BY \_\_\_\_\_ TITLE \_\_\_\_\_ DATE \_\_\_\_\_



Description	Quantity	Unit Price	Extended Price										
<b>Category C AMQ</b>													
<b>1 BXBYARMLESS - AMQ Bixby Chair Armless</b> Cushion: No Cushion Frame Finish: Paint PC03 - Platinum Seat Shell Finish: Plastic PL03 - Platinum Back Shell Finish: Plastic PL03 - Platinum Castors or Glides: Soft Castors Accessories: No Accessory Storage Tray: No Storage Tray AMQ SOLUTI Tag For C1	76	152.04	11,555.04										
<table border="0"> <thead> <tr> <th>Qty</th> <th>Description</th> </tr> </thead> <tbody> <tr> <td>4</td> <td>Conference Room A102</td> </tr> <tr> <td>72</td> <td>Large Group Room B112</td> </tr> </tbody> </table>				Qty	Description	4	Conference Room A102	72	Large Group Room B112				
Qty	Description												
4	Conference Room A102												
72	Large Group Room B112												
<b>2 BXBYARMLESS - AMQ Bixby Chair Armless</b> Cushion: No Cushion Frame Finish: Paint PC03 - Platinum Seat Shell Finish: Plastic PL06 - Wasabi Back Shell Finish: Plastic PL06 - Wasabi Castors or Glides: Soft Castors Accessories: No Accessory Storage Tray: No Storage Tray AMQ SOLUTI Tag For C2	92	152.04	13,987.68										
<table border="0"> <thead> <tr> <th>Qty</th> <th>Description</th> </tr> </thead> <tbody> <tr> <td>36</td> <td>Flex Classroom A107</td> </tr> <tr> <td>36</td> <td>Flex Classroom A108</td> </tr> <tr> <td>4</td> <td>Robotics Field A116</td> </tr> <tr> <td>16</td> <td>Commons A110</td> </tr> </tbody> </table>				Qty	Description	36	Flex Classroom A107	36	Flex Classroom A108	4	Robotics Field A116	16	Commons A110
Qty	Description												
36	Flex Classroom A107												
36	Flex Classroom A108												
4	Robotics Field A116												
16	Commons A110												
<b>3 LOT - Non-Union, normal hours.</b> Receive, Deliver, and Installation of Product. One phase. Elevator access, as necessary Free and clear space No Removal of Existing Product  Overtime Labor, if required, would be an additional charge.  Storage free for 30 days. After which storage is charged per LF per month.	1	3,867.60	3,867.60										

TITLE OF PRODUCT TRANSFERS UPON RECEIPT BY CUSTOMER.

ACCEPTED BY \_\_\_\_\_ TITLE \_\_\_\_\_ DATE \_\_\_\_\_

Description	Quantity	Unit Price	Extended Price
3 ROSE MOVIN			
<b>Sub Total</b>			<b>29,410.32</b>
<b>Total</b>			<b>29,410.32</b>

**Category D Smith System**

4	<b>SMPLN01265</b> - Planner Huddle Desk-Circle, 6-Student <b>Worksurface Finish:</b> SMITH SYSTEM LAMINATE 494360 - CLASSIC LINEN LAMINATE <b>Edge Type:</b> F - 1 1/4in Top w 3mm Edgbnd <b>Edge Finish:</b> Smith System Plastic CHAMPAGN - CHAMPAGNE <b>Leg Finish:</b> SMITH SYSTEM PAINT PLT - PLATINUM SMITH SYST <b>Tag For</b> D1	72	213.60	15,379.20
---	---	----	--------	-----------

**Qty Description**

36	Flex Classroom A107
36	Flex Classroom A108

5	<b>SMEMTNL2460</b> - Elemental; Table-Nest and fold, With casters, 24D x 60W <b>Worksurface Finish:</b> Smith System Laminate 494360 - CLASSIC LINEN LAMINATE <b>Edge Type:</b> F-1 1/4in Top w 3mm Edgbnd <b>Edge Finish:</b> Smith System Plastic CHAMPAGN - CHAMPAGNE <b>Leg Finish:</b> Smith System Paint PLT - Platinum <b>Height:</b> EJ - Adjustable Height SMITH SYST <b>Tag For</b> D2	2	763.80	1,527.60
---	---	---	--------	----------

**Qty Description**

2	Robotics Field A116
---	---------------------

6	<b>SMEMTEL3060</b> - Elemental; Table-Rectangle, 30D x 60W <b>Worksurface Finish:</b> Smith System Laminate 494360 - CLASSIC LINEN LAMINATE <b>Edge Type:</b> F-1 1/4in Top w 3mm Edgbnd <b>Edge Finish:</b> Smith System Plastic CHAMPAGN - CHAMPAGNE <b>Leg Finish:</b> Smith System Paint PLT - Platinum <b>Height:</b> EG - Fixed Height w/ Glide SMITH SYST <b>Tag For</b> D3	1	390.00	390.00
---	---	---	--------	--------

**Qty Description**

1	Conference Room A102
---	----------------------

TITLE OF PRODUCT TRANSFERS UPON RECEIPT BY CUSTOMER.

ACCEPTED BY \_\_\_\_\_ TITLE \_\_\_\_\_ DATE \_\_\_\_\_

Description	Quantity	Unit Price	Extended Price
<b>7</b> <b>17576</b> - 3" CASTER PK 4LK 3/8THD PU TRD SMITH SYST <b>Tag For</b> for use with D1 & D3 TABLE	73	61.20	4,467.60
<b>9</b> <b>FREIGHT</b> - FREIGHT SMITH SYST	1	2,550.00	2,550.00
<b>10</b> <b>LOT</b> - Non-Union, normal hours. Receive, Deliver, and Installation of Product. One phase. Elevator access, as necessary Free and clear space No Removal of Existing Product  Overtime Labor, if required, would be an additional charge.  Storage free for 30 days. After which storage is charged per LF per month. ROSE MOVIN	1	5,248.89	5,248.89

<b>Sub Total</b>	<b>29,563.29</b>
<b>Total</b>	<b>29,563.29</b>

**Category L Global alternate**

<b>11</b> <b>6244BL</b> - Boltless Steel & Particle Board Shelving 48 x 24 X 72, Black 5 SHELVES SAFCO PROD <b>Tag For</b> L1	5	228.66	1,143.30
<b>12</b> <b>6247BL</b> - Boltless Steel & Particle Board Shelving 36 x 24"x 72 Black 5 shelves SAFCO PROD <b>Tag For</b> L2	9	195.05	1,755.45
<b>13</b> <b>LOT</b> - Non-Union, normal hours. Receive, Deliver, and Installation of Product. One phase. Elevator access, as necessary Free and clear space No Removal of Existing Product  Overtime Labor, if required, would be an additional charge.  Storage free for 30 days. After which storage is charged per LF per month. ROSE MOVIN	1	2,000.00	2,000.00

TITLE OF PRODUCT TRANSFERS UPON RECEIPT BY CUSTOMER.

ACCEPTED BY \_\_\_\_\_ TITLE \_\_\_\_\_ DATE \_\_\_\_\_

yourNBS.com

Remit Payments to: NBS, 6973 Reliable Parkway, Chicago, IL 60686

Description	Quantity	Unit Price	Extended Price
<b>Sub Total</b>			<b>4,898.75</b>
<b>Total</b>			<b>4,898.75</b>

**Category B Steelcase**

14 **TS4TLP40** - Campfire; Big Table, Power cutout, 96W x 48D x 40H 2 2,627.06 5,254.12  
**TOP OPT:** \*OPT:TOP OPTION  
**HPL TOP:** HPL TOP  
**TOP-SURF:** TOP SURFACE  
**LAM HPL:** \*TOP-SURF:LAMINATE (HPL)  
**2511:** WINTER ON MAPLE  
**CON OPT:** \*OPT:CONTRASTING MODESTY PNL OPTION  
**NOCONMOD:** NO CONTRASTING MODESTY PANEL  
**PWR OPT:** \*OPT:POWER OPTIONS  
**1PWR1USB:** RECEPTACLE 1 PWR 1 USB  
**GROMMET:** GROMMET  
**TEXTPNT:** \*GROMMET:TEXTURED PAINT  
**7241:** ARCTIC WHITE

STEELCASE

Tag For B1

**Qty Description**

2 Commons A101

15 **COM FABRIC** - CF STINSON FUSE 2.0 CHARCOAL 1 425.00 425.00  
 NBS TROY  
 Tag For B2

16 **TS31401H** - Jenny; Chair, High pressure laminate, No arms 4 1,094.80 4,379.20  
**EDGE:** 6037 WINTER ON MAPLE  
**TOP-SURF:** 2511 WINTER ON MAPLE  
**UPHLSTRY:** 5999 MISC FABRIC  
 CF STINSON INC - Acct 140021  
 Purchaser: VENDOR  
 Pattern: FUSE 2.0 -FSE  
 Color: CHARCOAL -241  
 Direction: HORIZONTAL

**LEG OPT:** \*OPT:LEG OPTIONS

**ALUMINUM:** ALUMINUM LEGS

STEELCASE

Tag For B2

**Qty Description**

TITLE OF PRODUCT TRANSFERS UPON RECEIPT BY CUSTOMER.

ACCEPTED BY \_\_\_\_\_ TITLE \_\_\_\_\_ DATE \_\_\_\_\_

Description	Quantity	Unit Price	Extended Price	
16	4 COMMONS A101			
18	<p><b>LOT</b> - Non-Union, normal hours.                      Receive, Deliver, and Installation of Product. One phase.                      Elevator access, as necessary                      Free and clear space                      No Removal of Existing Product</p> <p>Overtime Labor, if required, would be an additional charge.</p> <p>Storage free for 30 days. After which storage is charged per LF per month.                      ROSE MOVIN</p>	1	736.69	736.69
<b>Sub Total</b>			<b>10,795.01</b>	
<b>Total</b>			<b>10,795.01</b>	
<b>Category A Erg</b>				
19	<p><b>8306</b> - 8306/GD2                      RAVEN 44"W STRAIGHT MODULAR UNIT                      SEAT HEIGHT: 18"                      BACK HEIGHT: 33"                      FABRIC: GRADE 5                      BACK: CF STINSON FUSE 2.0 SLATE FSE-238                      FABRIC DIR BACK: RAILROAD OR OFF THE BOLT TBD                      SEAT: CF STINSON FUSE 2.0 SLATE FSE-238                      FABRIC DIR SEAT: RAILROAD OR OFF THE BOLT TBD                      LEGS: BRUSHED ALUMINUM                      GD2: FLAT GANGING DEVICE                      ERG INTERN</p> <p><b>Tag For</b> A1</p>	6	1,713.04	10,278.24
	<p style="text-align: center;"><b>Qty Description</b></p> <hr/> <p style="text-align: center;">6 Commons A101</p>			
20	<p><b>GD2</b> - FLAT GANGING DEVICE                      ERG INTERN</p> <p><b>Tag For</b> A1</p>	5	52.43	262.15
21	<p><b>8302</b> - 8302/GD2                      RAVEN 22"W STRAIGHT MODULAR UNIT                      SEAT HEIGHT: 18"                      BACK HEIGHT: 33"                      FABRIC: GRADE 5                      BACK: CF STINSON FUSE 2.0 SLATE FSE-238                      FABRIC DIR BACK: RAILROAD OR OFF THE BOLT TBD                      SEAT: CF STINSON FUSE 2.0 SLATE FSE-238                      FABRIC DIR SEAT: RAILROAD OR OFF THE BOLT TBD                      LEGS: BRUSHED ALUMINUM</p>	2	1,038.80	2,077.60

TITLE OF PRODUCT TRANSFERS UPON RECEIPT BY CUSTOMER.

ACCEPTED BY \_\_\_\_\_ TITLE \_\_\_\_\_ DATE \_\_\_\_\_

yourNBS.com

Remit Payments to: NBS, 6973 Reliable Parkway, Chicago, IL 60686

Description	Quantity	Unit Price	Extended Price						
<b>21</b> GD2: FLAT GANGING DEVICE ERG INTERN Tag For A2 <table border="0" style="margin-left: 40px;"> <tr> <td style="text-align: right;"><b>Qty</b></td> <td><b>Description</b></td> </tr> <tr> <td style="border-top: 1px solid black; text-align: right;">2</td> <td style="border-top: 1px solid black;">Commons A101</td> </tr> </table>	<b>Qty</b>	<b>Description</b>	2	Commons A101					
<b>Qty</b>	<b>Description</b>								
2	Commons A101								
<b>22</b> GD2 - FLAT GANGING DEVICE ERG INTERN Tag For A2	1	52.43	52.43						
<b>23</b> 8386 - 8386/GD2 RAVEN CORNER UNIT W/ SQUARE BACK SEAT HEIGHT: 18" BACK HEIGHT: 33" FABRIC: GRADE 5 BACK: CF STINSON FUSE 2.0 SLATE FSE-238 FABRIC DIR BACK: RAILROAD OR OFF THE BOLT TBD SEAT: CF STINSON FUSE 2.0 SLATE FSE-238 FABRIC DIR SEAT: RAILROAD OR OFF THE BOLT TBD GD2: FLAT GANGING DEVICE ERG INTERN Tag For A3 <table border="0" style="margin-left: 40px;"> <tr> <td style="text-align: right;"><b>Qty</b></td> <td><b>Description</b></td> </tr> <tr> <td style="border-top: 1px solid black; text-align: right;">3</td> <td style="border-top: 1px solid black;">Commons A101</td> </tr> </table>	<b>Qty</b>	<b>Description</b>	3	Commons A101	3	1,810.06	5,430.18		
<b>Qty</b>	<b>Description</b>								
3	Commons A101								
<b>24</b> GD2 - FLAT GANGING DEVICE ERG INTERN Tag For A3	2	52.43	104.86						
<b>25</b> CAP105-LAM - CAPRI TABLE TABLE W/ LAMINATE TOP TABLE HEIGHT: 26" BASE SHAPE: RECTANGLE TOP SHAPE: ALMOST RECTANGLE - 13"X18" LAMINATE: WILSONART MANITOBA MAPLE 7911-60 EDGE DETAIL: GR 6F .75" MULTIPLY FLAT EDGE STAIN: STANDARD TBD BASE: BRUSHED ALUMINUM ERG INTERN Tag For A4 <table border="0" style="margin-left: 40px;"> <tr> <td style="text-align: right;"><b>Qty</b></td> <td><b>Description</b></td> </tr> <tr> <td style="border-top: 1px solid black; text-align: right;">6</td> <td style="border-top: 1px solid black;">Commons A101</td> </tr> <tr> <td style="text-align: right;">4</td> <td>Large Group Room B112</td> </tr> </table>	<b>Qty</b>	<b>Description</b>	6	Commons A101	4	Large Group Room B112	10	491.47	4,914.70
<b>Qty</b>	<b>Description</b>								
6	Commons A101								
4	Large Group Room B112								
<b>26</b> DUN24D - DUNCAN 24"D OCCASIONAL TABLE TABLE HEIGHT: 18" LAMINATE: WILSONART MANITOBA MAPLE 7911-60 LEGS: BRUSHED ALUMINUM	1	1,027.04	1,027.04						

TITLE OF PRODUCT TRANSFERS UPON RECEIPT BY CUSTOMER.

ACCEPTED BY \_\_\_\_\_ TITLE \_\_\_\_\_ DATE \_\_\_\_\_

yourNBS.com

Remit Payments to: NBS, 6973 Reliable Parkway, Chicago, IL 60686

Description	Quantity	Unit Price	Extended Price
<b>26</b> ERG INTERN <b>Tag For</b> A5  <div style="margin-left: 100px;"> <b>Qty Description</b>  <hr/>                     1 Commons A101                 </div>			
<b>27</b> <b>8380</b> - 8380/2FO RAVEN 48"W BACK TO BACK BANQUETTE SEAT HEIGHT: 18" BACK HEIGHT: 33" OVERALL DEPTH: 51.5" FABRIC: GRADE 6 BACK: DESIGNTEX BIG DOT SMOKE 3525-803 FABRIC DIR BACK: RAILROAD OR OFF THE BOLT TBD SEAT: CF STINSON FUSE 2.0 PEACOCK FSE 223 FABRIC DIR SEAT: RAILROAD OR OFF THE BOLT TBD LEGS: BRUSHED ALUMINUM 2FO: TWO FABRIC OPTION ERG INTERN <b>Tag For</b> A6  <div style="margin-left: 100px;"> <b>Qty Description</b>  <hr/>                     3 Commons A110                 </div>	3	3,808.77	11,426.31
<b>28</b> <b>8372</b> - 8372/2FO RAVEN 48" W BANQUETTE SEAT HEIGHT: 18" BACK HEIGHT: 33" FABRIC: GRADE 6 BACK: DESIGNTEX BIG DOT SMOKE 3525-803 FABRIC DIR BACK: RAILROAD OR OFF THE BOLT TBD SEAT: CF STINSON FUSE 2.0 PEACOCK FSE 223 FABRIC DIR SEAT: RAILROAD OR OFF THE BOLT TBD LEGS: BRUSHED ALUMINUM 2FO: TWO FABRIC OPTION ERG INTERN <b>Tag For</b> A7  <div style="margin-left: 100px;"> <b>Qty Description</b>  <hr/>                     1 Commons A110                 </div>	1	2,035.46	2,035.46
<b>29</b> <b>MON24D</b> - MON42D/SF MONACO 42"D TABLE TABLE HEIGHT: 29" BASE SPREAD: 1-22"S BASE LAMINATE: WILSONART MANITOBA MAPLE 7911-60 EDGE DETAIL: GR 3A 3MM X 1.25" FLAT PVC EDGE COLOR: STANDARD TBD BASE: BRUSHED ALUMINUM SF: POWDERCOAT FINISH ERG INTERN <b>Tag For</b> A8	4	808.50	3,234.00

TITLE OF PRODUCT TRANSFERS UPON RECEIPT BY CUSTOMER.

ACCEPTED BY \_\_\_\_\_ TITLE \_\_\_\_\_ DATE \_\_\_\_\_



Description	Quantity	Unit Price	Extended Price				
<b>29</b> <table border="0" style="width: 100%;"> <tr> <td style="text-align: right;"><b>Qty</b></td> <td><b>Description</b></td> </tr> <tr> <td style="text-align: right;">4</td> <td>Commons A110</td> </tr> </table>	<b>Qty</b>	<b>Description</b>	4	Commons A110			
<b>Qty</b>	<b>Description</b>						
4	Commons A110						
<b>30</b> <b>MON3048-PVC</b> - MON3048/SF MONACO 30X48 TABLE TABLE HEIGHT: 29" BASE SPREAD: 2-17"SQ BASES LAMINATE: WILSONART MANITOBA MAPLE 7911-60 EDGE DETAIL: GR 3A 3MM X 1.25" FLAT PVC EDGE COLOR: STANDARD TBD BASE: BRUSHED ALUMINUM SF: POWDERCOAT FINISH ERG INTERN <b>Tag For</b> A9 <table border="0" style="width: 100%;"> <tr> <td style="text-align: right;"><b>Qty</b></td> <td><b>Description</b></td> </tr> <tr> <td style="text-align: right;">4</td> <td>Commons A110</td> </tr> </table>	<b>Qty</b>	<b>Description</b>	4	Commons A110	4	795.27	3,181.08
<b>Qty</b>	<b>Description</b>						
4	Commons A110						
<b>31</b> <b>DAK48D-PVC</b> - DAK48D/CAS3/FLIPX DAKOTA 48"D TABLE TABLE HEIGHT: 29" BASE SPREAD: 1-38"X BASE LAMINATE: WILSONART MANITOBA MAPLE 7911-60 EDGE DETAIL: GR 3A 3MM X 1.25" FLAT PVC EDGE COLOR: STANDARD TBD BASE: BRUSHED ALUMINUM CAS3: 3"D BLACK LOCKING CASTERS FLIPX: FLIP TOP MECHANISM ERG INTERN <b>Tag For</b> A10 <table border="0" style="width: 100%;"> <tr> <td style="text-align: right;"><b>Qty</b></td> <td><b>Description</b></td> </tr> <tr> <td style="text-align: right;">12</td> <td>Large Group Room B112</td> </tr> </table>	<b>Qty</b>	<b>Description</b>	12	Large Group Room B112	12	1,108.87	13,306.44
<b>Qty</b>	<b>Description</b>						
12	Large Group Room B112						
<b>32</b> <b>LOT</b> - Non-Union, normal hours. Receive, Deliver, and Installation of Product. One phase. Elevator access, as necessary Free and clear space No Removal of Existing Product  Overtime Labor, if required, would be an additional charge.  Storage free for 30 days. After which storage is charged per LF per month. ROSE MOVIN	1	3,798.54	3,798.54				
<b>Sub Total</b>			<b>61,129.03</b>				
<b>Total</b>			<b>61,129.03</b>				
<b>33</b> <b>CONTINGENCY</b> - Estimating 3-4 days for install  If due to unforeseen circumstances the building is not ready to <small>TITLE OF PRODUCT TRANSFERS UPON RECEIPT BY CUSTOMER.</small>	1	N/C	N/C				





2595 Bellingham • Troy, MI 48083 • 248.823.5400 • 248.823.5401 Fax  
 2211 Old Earhart Rd. Ste.190 • Ann Arbor, MI 48105 • 248.823.5400 • 248.823.5401 Fax  
 3201 Pine Tree Rd. Ste. A • Lansing, MI 48911 • 517.886.0072 • 248.823.5401 Fax  
 5160 Alliance Dr. • Bay City, MI 48706 • 989.895.8574 • 989.895.8545 Fax  
 4 North St. Clair St. • Toledo, OH 43604 • 419.662.2040 • 248.823.5401 Fax

**Quotation 357940**  
 Page 10 / 10 (cont'd)

yourNBS.com

Remit Payments to: NBS, 6973 Reliable Parkway, Chicago, IL 60686

Description	Quantity	Unit Price	Extended Price
<p><b>33</b> receive furniture, including construction delays, additional fees may be incurred to double handle and/or store the furniture. Installation is quoted as one phase.</p> <p>Additional Trip charge cost to return to site and complete installation: \$300</p> <p>Storage fee per month: \$1365 for all product ROSE MOVIN</p>			

Quotation Totals	
Sub Total	<b>135,796.40</b>
Grand Total	<b>135,796.40</b>

End of Quotation

TITLE OF PRODUCT TRANSFERS UPON RECEIPT BY CUSTOMER.

ACCEPTED BY \_\_\_\_\_ TITLE \_\_\_\_\_ DATE \_\_\_\_\_

FAMILIAL RELATIONSHIP DISCLOSURE STATEMENT

As required by Public Act 232 of 2004, all bids shall be accompanied by a sworn and notarized statement disclosing any familial relationship that exists between the owner or any employee of the bidder and any member of the Northville Public Schools Board of Education or the Superintendent of Schools. The Board of Education shall not accept a bid that does not include this sworn and notarized disclosure statement.

The undersigned, the owner or authorized officer of NBS (the "Bidder"), pursuant to the familial disclosure requirement provided in the Livonia Public Schools advertisement for construction bids, hereby represent and warrant, except as provided below, that no familial relationships exist between the owner(s) or any employee of the company and any member of the Livonia Public Schools Board of Education or the Superintendent of Schools. If such a relationship exists, please explain:

---

---

---

---

Attach additional pages if necessary

By: [Signature] (Bidder Signature)  
Title: workplace specialist (type or print)  
Date: 12/20/22

Subscribed and Sworn to Before Me:

This 20th day of December, 2022 A.D., in and for the  
County of Oakland, Michigan.

My Commission expires 2/7/27.

[Signature]  
Signature of Notary

BRETT BARKACS  
NOTARY PUBLIC - STATE OF MICHIGAN  
COUNTY OF OAKLAND  
My Commission Expires February 7, 2027  
Acting in the County of Oakland

NON-COLLUSION AFFIDAVIT

STATE OF MICHIGAN        )  
  )  
WAYNE COUNTY            )        ss:

The undersigned bidder or agent, being duly sworn on oath, says that he/she has not, nor has any other member, representative, or agent of the firm, company, corporation or partnership represented by him/her, entered into any combination, collusion or agreement with any person relative to the price to be bid by anyone at such letting nor to prevent any person from bidding nor to induce anyone to refrain from bidding, and that this bid is made without reference to any other bid and without any agreement, understanding or combination with any other person in reference to such bidding.

He/she further says that no person or persons, firms, or corporation has, have or will receive directly or indirectly, any rebate, gift, fee, commission or thing of value on account of such sale.

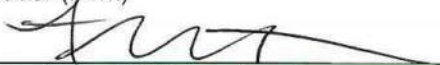
NBS  
\_\_\_\_\_  
Bidder (Firm)  
  
\_\_\_\_\_  
Signature of Bidder or Agent

Subscribed and sworn to before me this 29<sup>th</sup> day of December, 2022.

My commission expires: 2/7/27

County of residence: Oakland

  
\_\_\_\_\_  
Notary Public Signature

Seal

BRETT BARKACS  
NOTARY PUBLIC – STATE OF MICHIGAN  
COUNTY OF OAKLAND  
My Commission Expires February 7, 2027  
Acting in the County of Oakland

CERTIFICATION OF COMPLIANCE – IRAN ECONOMIC SANCTIONS ACT  
Michigan Public Act No. 517 of 2012

The undersigned, the owner, or authorized officer of the below-named company (the "Company"), pursuant to the compliance certification requirement provided in the Livonia Public Schools Request For Proposal (the "RFP"), hereby certifies, represents, and warrants that the Company (which includes its officers, directors and employees) is not an "Iran Linked Business" within the meaning of the Iran Economic Sanctions Act, Michigan Public Act No. 517 of 2012 (the "Act"), and that in the event the Company is awarded a contract by the Livonia Public Schools Board of Education as a result of the aforementioned RFP, the Company is not and will not become an "Iran Linked Business" at any time during the course of performing any services under the contract.

The Company further acknowledges that any person who is found to have submitted a false certification is responsible for a civil penalty of not more than \$250,000.00 or two (2) times the amount of the contract or proposed contract for which the false certification was made, whichever is greater, the cost of the Livonia Public Schools' investigation, and reasonable attorney fees, in addition to the fine. Moreover, any person who submitted a false certification shall be ineligible to bid on a request for proposal for three (3) years from the date that it is determined that the person has submitted the false certification.

NBS  
Name of Company

Anne Marie Trembuth  
workplace Specialist  
Name and Title of Authorized Representative

[Signature]  
Signature

12/20/22  
Date

\*\*END OF SECTION\*\*





QUOTATION: 22CAH-607768/C

# Livonia Stem - Dec 16

CREATED 11/1/2022 | REVISED 1/11/2023 | Valid Through 2/28/2023



# Livonia Stem - Dec 16

KI is pleased to present the enclosed quotation. The following items are included:

- Quote
- Summary
- Itemized Quote
- Detailed PO requirements
- Product Options

Quote Number: 22CAH-607768/C

*CREATED 11/1/2022 | REVISED 1/11/2023 | Valid Through 2/28/2023*

PRODUCT TOTALS	\$28,613.12
See Quote Detail Summary	\$0.00
<b>GRAND TOTAL</b>	<b>\$28,613.12</b>

**Contract Information:**

OT8142BZ1 Sourcewell #121919-KII -Delv/Inst

**Requested Delivery Date:** To be Determined

**Sold To**

Livonia Public Schools  
 15125 Farmington Rd  
 Livonia, MI 48154  
 P. (734) 744-2500 F. (734) 744-2570

**End User**

Livonia Public Schools  
 15125 Farmington Rd  
 Livonia, MI 48154  
 P. (734) 744-2500 F. (734) 744-2570

**Ship To**

To be Determined

**Installation**

To be Determined

**Sales Team:**

Chris Halatek  
 Dealer Rep  
 chris.halatek@ki.com  
 248-408-0978

Daryl Wendt  
 Inside Sales  
 daryl.wendt@ki.com  
 (877) 639-0643



**Client Notes:**

Delivered and Installed Normal Hours M-F  
 Sourcewell KI Contract









**CREATED** 11/1/2022  
**VALID THROUGH** 2/28/2023  
**Prepared By** Chris Halatek  
**Quote Filename** Livonia Stem - Dec 16 - 22CAH-607768/C

Line	Model		Qty.		Sell Price	Extended Total	TBD Options
<b>Tag 1: Category E</b>							
2.1	DN4100H30 S22348645	*Modified-Doni Four-Leg Armless 30" Stool,Poly,Solid Color	6		\$294.00	\$2,264.00	
		Poly Seat & Back Color Poly Seat & Back Color NFR Poly Seat & Back Color NFR Poly Seat & Back Color NFR  Frame Color Glide Option		Compliance to TB 117-2013 NA PSK Sky Blue Per Order Net Upcharge  Starlight Silver Metallic Felt glides Additional 15 working days lead-time is required NON-STANDARD POLY- \$500 Setup Fee. If SKU total on order exceeds 100 units, fee will be waived (SKU=Product/Color)	/NFR NA *Modified Per Order One Time 500.00 Charge for Setup Chg Fee /SX /GFT Note: Lead-time Change External Note		
		<b>MK: E1</b> <b>Price Description: Delivered/Open Market</b> <b>Lead Time: 6 - 8 Weeks; Ships from GREEN BAY, WI</b> <b>Please Note: Leadtime calculated on 1/11/2023 and is subject to change.</b>					
2.4	DN4100H30	Doni Four-Leg Armless 30" Stool,Poly,Solid Color	12		\$294.00	\$3,528.00	
		Poly Seat & Back Color Poly Seat & Back Color NFR Frame Color Glide Option		Compliance to TB 117-2013 Zesty Lime Starlight Silver Metallic Steel glides	/NFR /PZL /SX /GSL		
		<b>MK: E2</b> <b>Price Description: Delivered/Open Market</b> <b>Lead Time: 3 - 5 Weeks; Ships from GREEN BAY, WI</b> <b>Please Note: Leadtime calculated on 1/11/2023 and is subject to change.</b>					
2.5	RKT301841OP/36T	Ruckus,Tote Storage,Tall,2-Column unit,Open,30"Wx18"Dx40-3/4"H,includes (10)3" totes,(4)6"totes	3		\$903.84	\$2,711.52	
		Storage Base Paint Color		4 black casters Sky Blue	/4CW /SK		
		<b>MK: E3</b> <b>Price Description: Delivered/Open Market</b> <b>Lead Time: 4 - 6 Weeks; Ships from PEMBROKE, ONT</b> <b>Please Note: Leadtime calculated on 1/11/2023 and is subject to change.</b>					
2.6	RKT301841DR/36T	Ruckus,Tote Storage,Tall,2-Column unit,w/Doors,30"Wx18"Dx40-3/4"H,includes (10)3" totes,(4)6"totes	2		\$1,057.28	\$2,114.56	
		Pull Option Storage Base Paint Color Door Color Lock Option Lock Color National Key Alike		Beveled pull Satin Chrome 4 black casters Sky Blue Sky Blue Key alike Satin Chrome Key Alike Lock #116	/S5 /4CW /SK /FSK /KA /SCL /L116		
		<b>MK: E4</b> <b>Price Description: Delivered/Open Market</b> <b>Lead Time: 4 - 6 Weeks; Ships from PEMBROKE, ONT</b> <b>Please Note: Leadtime calculated on 1/11/2023 and is subject to change.</b>					



**CREATED** 11/1/2022  
**VALID THROUGH** 2/28/2023  
**Prepared By** Chris Halatek  
**Quote Filename** Livonia Stem - Dec 16 - 22CAH-607768/C

Line	Model		Qty.		Sell Price	Extended Total	TBD Options
2.7	RKT301841DR/XT	Ruckus,Tote Storage,Tall,2-Column unit,w/Doors,30"Wx18"Dx40-3/4"H,Empty (Totes Must be Ordered Separately)	3		\$856.24	\$2,568.72	
		Pull Option Beveled pull Satin Chrome /S5 Storage Base 4 black casters /4CW Paint Color Sky Blue /SK Door Color Sky Blue /FSK Lock Option Key alike /KA Lock Color Satin Chrome /SCL National Key Alike Key Alike Lock #116 /L116 <b>MK: E5</b> <b>Price Description: Delivered/Open Market</b> <b>Lead Time: 4 - 6 Weeks; Ships from PEMBROKE, ONT</b> <b>Please Note: Leadtime calculated on 1/11/2023 and is subject to change.</b>					
2.8	RKATSSHELF S22348647	*Modified-Ruckus Tote storage removeable steel shelf with rail set	3		\$32.48	\$97.44	
		Paint Color NA Paint Color SKY BLUE *Modified Additional 10 working days lead-time is required Note: Lead-time Change <b>MK: E5</b> <b>Price Description: Delivered/Open Market</b> <b>Lead Time: 6 - 8 Weeks; Ships from PEMBROKE, ONT</b> <b>Please Note: Leadtime calculated on 1/11/2023 and is subject to change.</b>					
2.9	RKT301841DR/XT	Ruckus,Tote Storage,Tall,2-Column unit,w/Doors,30"Wx18"Dx40-3/4"H,Empty (Totes Must be Ordered Separately)	2		\$856.24	\$1,712.48	
		Pull Option Beveled pull Satin Chrome /S5 Storage Base 4 black casters /4CW Paint Color Sky Blue /SK Door Color Sky Blue /FSK Lock Option Key alike /KA Lock Color Satin Chrome /SCL National Key Alike Key Alike Lock #116 /L116 <b>MK: E6</b> <b>Price Description: Delivered/Open Market</b> <b>Lead Time: 4 - 6 Weeks; Ships from PEMBROKE, ONT</b> <b>Please Note: Leadtime calculated on 1/11/2023 and is subject to change.</b>					
2.10	RKT301828OP/36T	Ruckus,Tote Storage,Short,2-Column Unit,Open,30"Wx18"Dx27-3/4"H,includes (8)3" totes,(2)6" totes	3		\$751.52	\$2,254.56	
		Storage Base 4 black casters /4CW Paint Color Sky Blue /SK <b>MK: E7A</b> <b>Price Description: Delivered/Open Market</b> <b>Lead Time: 4 - 6 Weeks; Ships from PEMBROKE, ONT</b> <b>Please Note: Leadtime calculated on 1/11/2023 and is subject to change.</b>					
2.11	RKT301828OP/3T	Ruckus,Tote Storage,Short,2-Column unit,Open,30"Wx18"Dx27-3/4"H,includes (12)3" Totes	3		\$762.16	\$2,286.48	
		Storage Base 4 black casters /4CW Paint Color Sky Blue /SK <b>MK: E7B</b> <b>Price Description: Delivered/Open Market</b> <b>Lead Time: 4 - 6 Weeks; Ships from PEMBROKE, ONT</b> <b>Please Note: Leadtime calculated on 1/11/2023 and is subject to change.</b>					





**CREATED** 11/1/2022  
**VALID THROUGH** 2/28/2023  
**Prepared By** Chris Halatek  
**Quote Filename** Livonia Stem - Dec 16 - 22CAH-607768/C

Line	Model		Qty.		Sell Price	Extended Total	TBD Options	
2.12	RKT301828OP/6T	 Ruckus, Tote Storage, Short, 2-Column Unit, Open, 30"Wx18"Dx27-3/4"H, includes (6) 6" Totes Storage Base Paint Color	4	4 black casters Sky Blue	/4CW /SK \$707.84	\$2,831.36		
		<b>MK: E7C</b> <b>Price Description: Delivered/Open Market</b> <b>Lead Time: 4 - 6 Weeks; Ships from PEMBROKE, ONT</b> <b>Please Note: Leadtime calculated on 1/11/2023 and is subject to change.</b>						
2.14	618WA	 600 Series Industrial Stool, Wood Seat, Adj Ht, 19-27"H Stool Frame Color	50	Warm Grey	/WG \$124.88	\$6,244.00		
		<b>MK: E8</b> <b>Price Description: Delivered/Open Market</b> <b>Lead Time: 4 - 6 Weeks; Ships from BONDUEL, WI</b> <b>Please Note: Leadtime calculated on 1/11/2023 and is subject to change.</b>						
<b>Tag 1: Category E</b>						<b>WorkGroup Product Subtotal</b>	<b>\$28,613.12</b>	

**Quote Summary**

**Product SubTotal: \$28,613.12**  
**Estimated Sales Tax: See Notes**  
**Quote Total: \$28,613.12**

**NOTES:**

- Images shown above are intended for approximate visual reference only and may not represent the exact models, numbers, descriptions or options selected. Refer to the model number/description/options shown for full product specifications.
- Sales Tax (For Shipment within the United States Only): Estimated sales/use tax will be calculated when order is entered. It is the customer's responsibility to pay any applicable sales/use tax due upon invoicing. A customer will not be charged sales tax if (1) a Resale Certificate, (2) an Exempt Organization Certificate, or (3) a Direct Pay permit is on file with KI's Finance Department. If no certificate is on file, the appropriate sales/use tax rate in effect at shipment will be applied and tax will be added to the customer's invoice.
- This project contains non-standard items which are not returnable and not cancelable. The warranty on non-standard product that alters function is 1 year. The warranty on non-standard product that does not alter function, but only finish (i.e., paint or plastic color, laminate, grommet removal) matches that of the standard product. Modification to U.L. Listed products eliminates the listing. Product will not have U.L. Listing labels unless specifically spelled out on this quote.

**PROJECT LEAD TIME SUMMARY:**

- Manufacturing lead time begins once the order is complete and acknowledged. Delivery dates are determined per order based on the longest lead time per shipping location and are confirmed on the order acknowledgement.
 

<u>Shipping Location</u>	<u>MFG Lead Time Range</u>
BONDUEL, WI	4 - 6 Weeks
GREEN BAY, WI	6 - 8 Weeks
PEMBROKE, ONT	6 - 8 Weeks
- Lead times are subject to change based on quantities, manufacturing capacity and surface material selections. Laminate and/or fabrics outside the standard KI in-grade program may have extended lead time.
- For more information or questions regarding delivery consolidation, contact KI Customer Service.

Customer represents that the product information contained within this quote is complete and accurate. Changes to quantities and/or options/finishes will affect this quote. If applicable, other charges such as freight, tax, installation and/or delivery fees may be added at time of order.

Sales resulting from purchase orders issued by the customer to KI (Whether related to this quotation or otherwise) are governed and controlled by the Terms and Conditions found at [www.KI.com/terms](http://www.KI.com/terms)

Prepared by Chris Halatek  
Market Code: 2=2=K-12

Opportunity #: 607768

Quote Filename: Livonia Stem - Dec 16 - 22CAH-607768

#### Final Considerations:

To ensure your Purchase Order (PO) is processed quickly and efficiently, please adhere to the following requirements:

1. All purchase orders must be issued to KI or KI c/o the dealer with this address:  
KI  
1330 Bellevue Street  
Green Bay, WI 54302
2. The following items must be included on all purchase orders:
  - Sold To/Bill To Information: complete legal name, address, telephone number and fax number
  - Ship To Information: complete legal name, address, contact name, contact phone number
  - Purchase Order Number: a customer-specific identifier, typically a sequential purchase order number or requisition number
  - Issue Date: date the purchase order was issued
  - Sales Tax: applicable sales tax will be added upon KI invoicing. If tax exempt, customer must provide or have the tax exempt certificate on file at KI
  - Purchase Order Total: total of all items and services included on the purchase order
  - Authorization: signature of authorized purchasing agent or buying entity
  - Order Details: reference a fully optioned KI quote (ex: 11KGH-85432) or include all the information listed below
    - Quantity of each item
    - Complete model number, including all finish and option information (by line item)
    - Net purchase price (by line item)
    - Extended net purchase price (all line items)
    - Any additional applicable charges (ex: installation and/or delivery charges)
    - Contract name and/or number if pricing is based on a contract reference
3. Signatures on a quote or a worksheet cannot be accepted as a purchase order.
4. In the event that you do not have a formal Purchase Order process, please contact your KI Sales Representative or call 1-800-424-2432, and we will assist you with creating a PO.

We appreciate your cooperation in providing us with all the required information listed above on your Purchase Order. Complete information helps us serve you better. Thank you for your order.

**Purchase Orders that do not meet these requirements will be placed on hold until complete information is received by KI. Purchase orders on hold are not released to manufacturing or assigned a delivery date. KI order lead times begin once the order is released to manufacturing.**

FAMILIAL RELATIONSHIP DISCLOSURE STATEMENT

As required by Public Act 232 of 2004, all bids shall be accompanied by a sworn and notarized statement disclosing any familial relationship that exists between the owner or any employee of the bidder and any member of the Northville Public Schools Board of Education or the Superintendent of Schools. The Board of Education shall not accept a bid that does not include this sworn and notarized disclosure statement.

The undersigned, the owner or authorized officer of Interior Office Source Inc. (the "Bidder"), pursuant to the familial disclosure requirement provided in the Livonia Public Schools advertisement for construction bids, hereby represent and warrant, except as provided below, that no familial relationships exist between the owner(s) or any employee of the company and any member of the Livonia Public Schools Board of Education or the Superintendent of Schools. If such a relationship exists, please explain:

\_\_\_\_\_  
\_\_\_\_\_  
\_\_\_\_\_

Attach additional pages if necessary

By: [Signature] (Bidder Signature)  
Title: PRESIDENT (type or print)  
Date: 12-19-22

Subscribed and Sworn to Before Me:

This 19<sup>th</sup> day of December, 2022 A.D., in and for the  
County of Livingston, Michigan.

My Commission expires 09/09/2027

Melanie Alice Murrell  
Signature of Notary

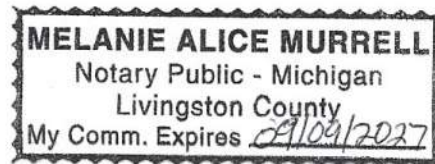

NON-COLLUSION AFFIDAVIT

STATE OF MICHIGAN        )  
  )  
WAYNE COUNTY            )        ss:

The undersigned bidder or agent, being duly sworn on oath, says that he/she has not, nor has any other member, representative, or agent of the firm, company, corporation or partnership represented by him/her, entered into any combination, collusion or agreement with any person relative to the price to be bid by anyone at such letting nor to prevent any person from bidding nor to induce anyone to refrain from bidding, and that this bid is made without reference to any other bid and without any agreement, understanding or combination with any other person in reference to such bidding.

He/she further says that no person or persons, firms, or corporation has, have or will receive directly or indirectly, any rebate, gift, fee, commission or thing of value on account of such sale.

INTERIOR OFFICE SOURCE  
Bidder (Firm)  
  
Signature of Bidder or Agent

Subscribed and sworn to before me this 19<sup>th</sup> day of December, 2022

My commission expires: 09/09/2027

County of residence: Livingston

Melanie Alice Murrell  
Notary Public Signature

Seal



CERTIFICATION OF COMPLIANCE – IRAN ECONOMIC SANCTIONS ACT  
Michigan Public Act No. 517 of 2012

The undersigned, the owner, or authorized officer of the below-named company (the "Company"), pursuant to the compliance certification requirement provided in the Livonia Public Schools Request For Proposal (the "RFP"), hereby certifies, represents, and warrants that the Company (which includes its officers, directors and employees) is not an "Iran Linked Business" within the meaning of the Iran Economic Sanctions Act, Michigan Public Act No. 517 of 2012 (the "Act"), and that in the event the Company is awarded a contract by the Livonia Public Schools Board of Education as a result of the aforementioned RFP, the Company is not and will not become an "Iran Linked Business" at any time during the course of performing any services under the contract.

The Company further acknowledges that any person who is found to have submitted a false certification is responsible for a civil penalty of not more than \$250,000.00 or two (2) times the amount of the contract or proposed contract for which the false certification was made, whichever is greater, the cost of the Livonia Public Schools' investigation, and reasonable attorney fees, in addition to the fine. Moreover, any person who submitted a false certification shall be ineligible to bid on a request for proposal for three (3) years from the date that it is determined that the person has submitted the false certification.

INTERIOR OFFICE SOURCE  
Name of Company

JOHN J. REIS PRESIDENT  
Name and Title of Authorized Representative

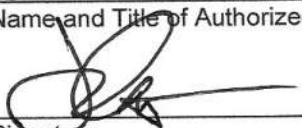
  
Signature

12-19-22  
Date

\*\*END OF SECTION\*\*





2195 South Milford Road, Milford MI 48381 Tel: 810-599-68

Date: 12/30/2022

<b>Customer:</b>	<b>Livonia Public School</b>	<b>Job Info:</b>	<b>Quote Number</b>
<b>Project Name:</b>	<b>Livonia CTC Robotics Addition Furnishing:</b>	<b>Contact:</b> Chris Halatek	
<b>Address:</b>	<b>8985 Newburgh Road</b>	<b>Contact Number:</b> 248-408-0978	<b>Ship to:</b> 2195 S Milford Road
<b>City, State Zip:</b>	<b>Livonia, MI 48150</b>	<b>Contact Email :</b> <a href="mailto:chris.halatek@interiorofficesource.com">chris.halatek@interiorofficesource.com</a>	<b>Suite E</b>
<b>Email:</b>		<b>Customer PO</b>	<b>Milford MI 48381</b>
<b>Phone:</b>		<b>Vendor</b> <a href="#">Wisconsin Bench</a>	
		<b>Contract</b> Peppm	PA- 528897-298
<b>Project Number</b>	<b>TMP 20136A Category F</b>	<b>Terms</b> Net 30	

**Product Information:**

Quantity:	Model #		Finishes	Sell Each:	Extended Sell
10	TOR9107-ASJG4-M-FJ	Toro Table with True Maple Top 48 x 48" D with Maple Butcher Block 1.75" Thick Top 1.5" Square Adjustable Leg 22-38"H Non Maring Nylon Glide TAG F1	True Maple Hard Block Paint Silver G4	\$ 1,658.00	\$ 16,580.00
7	TOR9069-ADJG4-M	Toro Table with True Maple Top 24 x 48" D with Maple Butcher Block 1.75" Thick Top 1.5" Square Adjustable Leg 22-38"H With Half Shelf CSHF Centered Non Maring Nylon Glide TAG F2	True Maple Hard Block Paint Silver G4	\$ 1,607.00	\$ 11,249.00
2	TOR9070ADJG4-M-HSHF 24	Toro Table with True Maple Top 24" x 54" D with Maple Butcher Block 1.75" Thick Top 1.5" Square Adjustable Leg 22-38"H Non Maring Nylon Glide TAG F3	True Maple Hard Block Paint Silver G4	1095.75	\$ 2,191.50
4	TOR9092-ADJG4-M-HSHF	Toro Table with True Maple Top 36 x 60" D with Maple Butcher Block 1.75" Thick Top 1.5" Square Adjustable Leg 22-38"H With Half Shelf CSHF Centered Non Maring Nylon Glide TAG F4	True Maple Hard Block Paint Silver G4	1924.75	\$ 7,699.00
		Installation 2023 Freight Included with PEPPM			\$ 2,100.00
		Quote expires 30 days		\$ 6,285.50	\$ 39,819.50



**Customer:** Livonia Public School District  
**Project Name:** CTC Robotics aAddition Furnishings  
**Address:** 8985 Newburgh Road  
**City, State Zip:** Livonia, MI 48154  
**Email:**  
**Phone:**  
**Category TMP:** H  
**Project Number:** 21036A

**Job Info:**  
**Contact:** Chris Halatek  
**Contact Number:** 248-408-0978  
**Contact Email :** [chris.halatek@interiorofficesource.com](mailto:chris.halatek@interiorofficesource.com)  
**Customer PO:** 2020-00001407  
**Vendor:** [Fleetwood Furniture](#)  
**Contract:** NCPA 07-27  
**Terms:** Net 30

**Quote Number:** FT21036A  
**Date:** 12/30/2002  
**Ship to:** The Interior Group

**Product Information:**

Quantity:	Model #		Finishes	Sell Each:	Extended Sell
3	25RS640	Tables Butcher Block top 60 W x 42D x 27-38.5H Adjustable Height with Crank	Maple Top	\$ 2,526.00	\$ 7,578.00
			Silver Paint		
		Tag H1			
		PO to Interior Office Source			
3		Installation First Floor, M-F 7AM - 3PM Freight Included with NCPA Contract Net 30			\$ 500.00
		Pricing expires in 60 Days			\$ 8,078.00



# Livonia Public Schools

---

## PRICE PROPOSAL

**Date: 1/3/2023**

---

Quote Number: 1713-26664

Valid For 25 Days

Prepared by: Steve Timmer

Confidential

© 2023 Dew-El Corporation. The information in this transmittal is proprietary to Dew-El Corporation. It is provided on the condition that it remains in confidence between Dew-El Corporation and the recipient of this quote. Do Not Copy, Distribute nor Share the Contents of this proposal without the written permission of Dew-El Corporation.



**Project Scope**

**Bill To**

Livonia Public Schools  
 15125 Farmington Road  
 Livonia, MI 48154

**Install To**

Livonia Career Technical Center  
 8985 Newburgh Rd  
 Livonia, MI 48150

**Project Investment**

Project Total	\$3,836.14
Tax (0%)	\$0.00
<b>Grand Total</b>	<b>\$3,836.14</b>

**Payment Schedule**

100% Due Net 30	<b>Net 30</b> \$3,836.14
-----------------	-----------------------------

**Price Summary by Phase**

Option	Phase / TAG	Price	Tax	Total
Livonia CTC and Robotics	Commons A101	\$2,936.14	\$0.00	\$2,936.14
	Freight	\$400.00	\$0.00	\$400.00
	Installation	\$500.00	\$0.00	\$500.00
<b>Grand Total</b>		<b>\$3,836.14</b>	<b>\$0.00</b>	<b>\$3,836.14</b>

Dew-El Corporation  
 10841 Paw Paw Drive  
 Holland, MI 49424  
 Phone: (616) 396-6554  
 Fax: (616) 396-6669  
<http://www.Dew-El.com>



# QUOTATION

# 1713-26664

VALID UNTIL 1/28/2023

## BILL TO

Livonia Public Schools  
 15125 Farmington Road  
 Livonia, MI 48154

## INSTALL TO



Livonia Career Technical Center  
 8985 Newburgh Rd  
 Livonia, MI 48150

Salesperson  
 Steve Timmer

Payment Terms  
 Net 30

## Livonia CTC and Robotics

### Commons A101

LINE #	QTY	UNIT	PART # / DESCRIPTION	PRICE EA	EXT PRICE
1	2.00	EA	CBLOX-17-17-G3 / Blox Seating - Cylinder 17" Dia x 17"H, Grade 3 High-Density Foam Interior, Grade 2 Fabric Exterior Cylinder Shape Fabric: Designtex Rise Penny 3809-701  Tag: G1	\$375.50	\$751.01
					
2	2.00	EA	CBLOX-17-17-G3 / Blox Seating - Cylinder 17" Dia x 17"H, Grade 3 High-Density Foam Interior, Grade 2 Fabric Exterior Cylinder Shape Fabric: Designtex Rise Grass 3809-502  Tag: G2	\$375.50	\$751.01
					
3	1.00	EA	CBLOX-17-17-G3 / Blox Seating - Cylinder 17" Dia x 17"H, Grade 3 High-Density Foam Interior, Grade 2 Fabric Exterior Cylinder Shape Fabric: Designtex Rise Pool 3809-403  Tag: G3	\$375.51	\$375.51
					
4	2.00	EA	CBLOX-17-17-G8 / Blox Seating - Cylinder 17" Dia x 17"H, Grade 8 High-Density Foam Interior, Grade 2 Fabric Exterior Cylinder Shape Fabric: CF Stinson La Scalina LAS14 Flow Tag: G4	\$529.30	\$1,058.61
					

### Freight

LINE #	QTY	UNIT	PART # / DESCRIPTION	PRICE EA	EXT PRICE
5	1.00	EA	Freight / Freight / Shipping / Packaging	\$400.00	\$400.00

### Installation

LINE #	QTY	UNIT	PART # / DESCRIPTION	PRICE EA	EXT PRICE
6	1.00	EA	INSTALL / Labor to Receive, Deliver, Install, and remove debris	\$500.00	\$500.00

Dew-El Corporation  
10841 Paw Paw Drive  
Holland, MI 49424  
Phone: (616) 396-6554  
Fax: (616) 396-6669  
<http://www.Dew-El.com>



# QUOTATION

# 1713-26664

VALID UNTIL 1/28/2023

## Livonia CTC and Robotics

### CUSTOMER SIGN OFF

subtotal	\$3,836.14
sales tax	\$0.00
<b>total</b>	<b>\$3,836.14</b>

\_\_\_\_\_  
Authorized Signature

\_\_\_\_\_  
Accepted Date

\_\_\_\_\_  
Print Name

FAMILIAL RELATIONSHIP DISCLOSURE STATEMENT

As required by Public Act 232 of 2004, all bids shall be accompanied by a sworn and notarized statement disclosing any familial relationship that exists between the owner or any employee of the bidder and any member of the Northville Public Schools Board of Education or the Superintendent of Schools. The Board of Education shall not accept a bid that does not include this sworn and notarized disclosure statement.

The undersigned, the owner or authorized officer of Dew-EI Corporation (the "Bidder"), pursuant to the familial disclosure requirement provided in the Livonia Public Schools advertisement for construction bids, hereby represent and warrant, except as provided below, that no familial relationships exist between the owner(s) or any employee of the company and any member of the Livonia Public Schools Board of Education or the Superintendent of Schools. If such a relationship exists, please explain:

\_\_\_\_\_  
\_\_\_\_\_  
\_\_\_\_\_

Attach additional pages if necessary

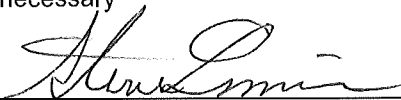
By: Steve Timmer  (Bidder Signature)

Title: Learning Environment Specialist (type or print)

Date: 12/21/2022

Subscribed and Sworn to Before Me:

This 22nd day of December, 2022 A.D., in and for the

County of Ottawa, Michigan.

My Commission expires 10-03-2023.

  
\_\_\_\_\_  
Signature of Notary

**RAQUEL PENA ROSAS**  
Notary Public, State of Michigan  
County of Ottawa  
My Commission Expires 10/03/2023  
Acting County of Ottawa

NON-COLLUSION AFFIDAVIT

STATE OF MICHIGAN        )  
  )  
WAYNE COUNTY                )        ss:

The undersigned bidder or agent, being duly sworn on oath, says that he/she has not, nor has any other member, representative, or agent of the firm, company, corporation or partnership represented by him/her, entered into any combination, collusion or agreement with any person relative to the price to be bid by anyone at such letting nor to prevent any person from bidding nor to induce anyone to refrain from bidding, and that this bid is made without reference to any other bid and without any agreement, understanding or combination with any other person in reference to such bidding.

He/she further says that no person or persons, firms, or corporation has, have or will receive directly or indirectly, any rebate, gift, fee, commission or thing of value on account of such sale.

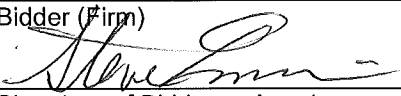
Dew-El Corporation  
\_\_\_\_\_  
Bidder (Firm)  
  
\_\_\_\_\_  
Signature of Bidder or Agent

Subscribed and sworn to before me this 22nd day of December, 20 22.

My commission expires: 10-03-2023

County of residence: Ottawa

  
\_\_\_\_\_  
Notary Public Signature

Seal

**RAQUEL PENA ROSAS**  
Notary Public, State of Michigan  
County of Ottawa  
My Commission Expires 10/03/2023  
Acting County of Ottawa

CERTIFICATION OF COMPLIANCE – IRAN ECONOMIC SANCTIONS ACT  
Michigan Public Act No. 517 of 2012

The undersigned, the owner, or authorized officer of the below-named company (the "Company"), pursuant to the compliance certification requirement provided in the Livonia Public Schools Request For Proposal (the "RFP"), hereby certifies, represents, and warrants that the Company (which includes its officers, directors and employees) is not an "Iran Linked Business" within the meaning of the Iran Economic Sanctions Act, Michigan Public Act No. 517 of 2012 (the "Act"), and that in the event the Company is awarded a contract by the Livonia Public Schools Board of Education as a result of the aforementioned RFP, the Company is not and will not become an "Iran Linked Business" at any time during the course of performing any services under the contract.

The Company further acknowledges that any person who is found to have submitted a false certification is responsible for a civil penalty of not more than \$250,000.00 or two (2) times the amount of the contract or proposed contract for which the false certification was made, whichever is greater, the cost of the Livonia Public Schools' investigation, and reasonable attorney fees, in addition to the fine. Moreover, any person who submitted a false certification shall be ineligible to bid on a request for proposal for three (3) years from the date that it is determined that the person has submitted the false certification.

Dew-EI Corporation  
Name of Company

Steve Timmer  
Name and Title of Authorized Representative

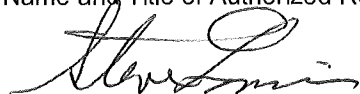
  
Signature

12/21/2022  
Date

\*\*END OF SECTION\*\*



Dew-El Corporation would like to thank you for the opportunity to quote your furniture needs. The attached proposal outlines the specifications and pricing based on the information provided. By signing and returning this quote, you agree to be bound by the terms and conditions contained herein which shall become the fully integrated agreement between you, the Client, and Dew-El Corporation.

**DELIVERY AND INSTALLATION**

1. Delivery/installation services are performed during normal business hours Monday through Friday 8:00am to 5:00pm unless otherwise specified; Client may incur additional charges for services performed after hours and/or weekends. All labor is quoted as a single-phase installation unless noted otherwise. If additional trips or phases are required due to the Client not being prepared for delivery or the site not being ready, it may result in added cost to the labor quote. Product will be delivered and installed on a mutually agreed upon date. All available spaces must be ready for furniture; installation of all carpet, painting, lighting, and ceiling tiles must be completed. If delivery and/or installation are requested by the Client to an uncompleted space, Client accepts responsibility for any damage to or theft of the product. The Client may request partial delivery and/or installation when placing the order. If so, the Client agrees to both take delivery and pay for all delivered items on a partial basis.
2. Prior to the installation, Dew-El Corporation is to be informed of the following guidelines or restrictions for proper access to the building: dock accessibility, sidewalks, parking lots, elevator access above the first floor, time restrictions, security checks or any safety requirements needed for access to your facility during the time of the installation. Any notification that delivery and/or installation cannot be accepted must be communicated to Dew-El Corporation no later than 12:00pm on the business day prior to the scheduled delivery and/or installation date. Dew-El Corporation requests product to be shipped by our manufacturers according to customer needs. If a Client has requested product to be installed by a specific date, Dew-El Corporation will work with the manufacturer to have all product received in time for the installation date requested by the customer. Dew-El Corporation shall not be held liable for manufacturing/delivery delays outside of Dew-El Corporation's control. If for any reason the customer delays the original installation date, Dew-El Corporation reserves the right to invoice for all product shipped according to the customer requested delivery date.

**SALES TAX**

Prices quoted include sales tax, and taxes will be included upon invoicing, unless an exemption certificate is furnished by the Client. If tax-exempt, please send a copy of your exemption certificate along with your signed quote.

**PAYMENT TERMS**

1. The following estimate is valid for 30 days. Payment terms are net due 30 days from invoice date, which is initiated upon shipment and/or fulfillment of service.
2. In the event of project delays due to construction, trades or equipment, the Client is expected to bring payments to a net retainage of 90% of the estimate. The Client is permitted to hold as retainage an amount equal to the value of uncompleted work, damaged or incorrect items.
3. Should Client default in payment of this Contract, charges shall be added from the date of default at the rate of one and one half percent (1 1/2%) per month, (18% per annum).
4. Client agrees to pay a Transaction Convenience fee of three point eight percent (3.8%) of the sell price shown on the proposal (including applicable sales tax) when the method of payment is in any form other than Dew-El Corporation's standard payment methods, which include cash, check, or ACH/direct deposit.

**ACCEPTANCE**

All sales are final; specified product is non-returnable and non-refundable. Claims for defects, errors or shortages must be made in writing within twenty business days after delivery. Failure to make a claim within such period shall constitute acceptance of the items.

**CANCELLATIONS AND CHANGES**

To accept the following estimate, drawings, specifications and delivery and installation conditions please sign both below and the last page of the estimate. If a purchase order is required for payment, that order number must be provided at the time of order placement. Any change(s) to an existing order may incur additional fees once the order has been placed. Such charges may include but not limited to; date moves, product changes/deletions, and "ship to" changes. Your signature approves Dew-El Corporation Terms and Conditions stated above.

Authorized Signature \_\_\_\_\_ Date \_\_\_\_\_

Title \_\_\_\_\_ PO No. \_\_\_\_\_

Company \_\_\_\_\_

Pricing for Media Technologies is provided according to National Purchasing Contract NCPA #07-42



# Proposal

Interior Environments - Novi  
 48700 Grand River Ave  
 Novi, MI 48374  
 Phone: (248) 213-3010

Order Number	12145
Date	01/05/2023
Customer PO No	
Customer Name	Livonia Public Schools
Salesperson	Bari Pfeiffer
Terms	NET 30
Page	1 of 6

T Livonia Public Schools  
 O 15125 Farmington Rd  
 Livonia, MI 48154  
  
 ATTN: INVOICE CONTACT  
 Email: ap@livoniapublicschools.org

S Livonia Career Technical Center  
 H 8985 Newburg Rd  
 I Livonia, MI 48150  
 P  
  
 T ATTN: Lauren Bush  
 O Phone: 248-338-4561  
 Email: lbush@tmp-architecture.com

Prepared for : Bari Pfeiffer

Allsteel - Omnia Contract R191802  
 Watson - NCPA 07-48

*Due to the current challenges in the global supply chain and labor environment, pricing and lead times remain in a state of flux. Our team will do it's best to communicate any changes as they arise and provide the best available solutions to meet your needs. Thank you for your business and understanding.*

Group	Quantity	Description	Unit Price	Extended Amount
ALLSTEEL	1.0		26,029.12	26,029.12

Line	Quantity	Description	Unit Price	Extended Amount
1	5.00 Each	Allsteel S922S2--.FSC-\$(5)-.FSE-238 Rise - 2 Tier .FSC:FSC Mixed Wood \$(5):Grade 5 Uph .FSE:Fuse 2.0 238:Slate Tag: Tag TG: LARGE GROUP ROOM B112 Tag L1: J1	1,645.42	8,227.10
2	3.00 Each	Allsteel S922S2--.FSC-\$(5)-.FSE-227 Rise - 2 Tier .FSC:FSC Mixed Wood \$(5):Grade 5 Uph .FSE:Fuse 2.0 227:Chive Tag: Tag TG: LARGE GROUP ROOM B112 Tag L1: J2	1,645.42	4,936.26
3	1.00 Each	Allsteel S922S3--.FSC-\$(5)-.FSE-227 Rise- 3 Tier .FSC:FSC Mixed Wood \$(5):Grade 5 Uph .FSE:Fuse 2.0 227:Chive Tag: Tag TG: LARGE GROUP ROOM B112 Tag L1: J3	1,810.06	1,810.06
4	2.00 Each	Allsteel S922S3--.FSC-\$(5)-.FSE-223	1,810.06	3,620.12





# Proposal

**Interior Environments - Novi**  
**48700 Grand River Ave**  
**Novi, MI 48374**  
**Phone: (248) 213-3010**

<b>Order Number</b>	12145
<b>Date</b>	01/05/2023
<b>Customer PO No</b>	
<b>Customer Name</b>	Livonia Public Schools
<b>Salesperson</b>	Bari Pfeiffer
<b>Terms</b>	NET 30
<b>Page</b>	2 of 6

		Rise- 3 Tier .FSC:FSC Mixed Wood \$(5):Grade 5 Uph .FSE:Fuse 2.0 223:Peacock Tag: Tag TG: LARGE GROUP ROOM B112 Tag L1: J4		
5	2.00 Each	Allsteel S922S2IC--.FSC-\$(5)-.FSE-223 2-Tier Inside Corner Rise .FSC:FSC Mixed Wood \$(5):Grade 5 Uph .FSE:Fuse 2.0 223:Peacock Tag: Tag TG: LARGE GROUP ROOM B112 Tag L1: J5	2,224.11	4,448.22
6	1.00 Each	Rose Moving and Storage LABOR---- INSTALLATION :(8) 2 TIER RISE :(3) 3 TIER RISE :(2) 2 TIER INSIDE CORNER RISE Tag: Tag TG: LARGE GROUP ROOM B112 Tag L1: GROUP J	1,855.00	1,855.00
7	1.00 Each	Allsteel TARIFF ALLSTEEL TARIFF Tag: Tag TG: LARGE GROUP ROOM B112 Tag L1: GROUP J	1,132.36	1,132.36

Group	Quantity	Description	Unit Price	Extended Amount
WATSON	1.0		13,344.41	13,344.41

Line	Quantity	Description	Unit Price	Extended Amount
9	11.00 Each	Watson Furniture Group WEM204660M--SAP ETCH MOBILE MARKERBOARD, 20"D x 46"W x 60"H SAP:POWDER FINISH- Sapphire Tag: Tag TG: (2) COMMONS A101, (6) ROBOTICS STUDIO A124, (1) COMMONS A110, (2) LARGE GROUP B112 Tag L1: K1	958.50	10,543.50
10	11.00 Each	Watson Furniture Group WEMC020304--SAP ETCH MARKER CUP, 2"D x 3"W x 4"H SAP:POWDER FINISH- Sapphire Tag: Tag TG: (2) COMMONS A101, (6) ROBOTICS STUDIO A124, (1) COMMONS A110, (2) LARGE GROUP B112 Tag L1: K1	45.00	495.00
11	1.00	Rose Moving and Storage	1,570.00	1,570.00



# Proposal

Interior Environments - Novi  
48700 Grand River Ave  
Novi, MI 48374  
Phone: (248) 213-3010

Order Number	12145
Date	01/05/2023
Customer PO No	
Customer Name	Livonia Public Schools
Salesperson	Bari Pfeiffer
Terms	NET 30
Page	3 of 6

	Each	LABOR--- INSTALLATION :(11) ETCH MOBILE MARKERBOARD :(11) ETCH MARKER CUP Tag: Tag TG: (2) COMMONS A101, (6) ROBOTICS STUDIO A124, (1) COMMONS A110, (2) LARGE GROUP B112 Tag L1: GROUP K		
12	1.00 Each	Watson Furniture Group TARIFF WATSON TARIFF Tag: Tag TG: (2) COMMONS A101, (6) ROBOTICS STUDIO A124, (1) COMMONS A110, (2) LARGE GROUP B112 Tag L1: GROUP K	735.91	735.91

Order Sub-Total :	\$39,373.53
<b>TOTAL ORDER :</b>	<b>\$39,373.53</b>
Required Deposit 50.0% :	\$19,686.77

PLEASE REVIEW THIS QUOTATION AND NOTIFY US PROMPTLY OF ANY CORRECTIONS REQUIRED      THANK YOU FOR THE OPPORTUNITY TO BE OF SERVICE

**A FINANCE CHARGE OF 1-1/2% PER MONTH WHICH IS AN ANNUAL PERCENTAGE RATE OF 18% WILL BE CHARGED ON ACCOUNTS PAST DUE.**

Signature: \_\_\_\_\_ Name: \_\_\_\_\_ Title: \_\_\_\_\_ Date: \_\_\_\_\_



# Proposal

Interior Environments - Novi  
48700 Grand River Ave  
Novi, MI 48374  
Phone: (248) 213-3010

Order Number	12145
Date	01/05/2023
Customer PO No	
Customer Name	Livonia Public Schools
Salesperson	Bari Pfeiffer
Terms	NET 30
Page	4 of 6

**Balco Interiors LLC and IE Connect LLC -  
d/b/a INTERIOR ENVIRONMENTS  
TERMS AND CONDITIONS OF SALE**

## 1. PROPOSALS AND ORDERS

- A. **TERM:** All prices quoted by Interior Environments ("Seller") are valid for 30 days from date of proposal.
- B. **OFFER AND ACCEPTANCE:** All orders for the purchase of goods and services from Seller require a proposal prepared by Seller which has been approved and signed by an authorized signatory of Buyer. Seller's proposal shall constitute an offer and Buyer's approval of the proposal shall constitute acceptance of that offer. If Buyer submits a purchase order before Seller issues a proposal, Seller's proposal shall constitute a counteroffer and Buyer's approval of the Seller's proposal shall constitute acceptance of that counter offer without any additional terms or conditions.
- C. **AGREEMENT:** Following the offer and acceptance described above and Seller's payment as provided in paragraph 2 below, an "Agreement" between the parties shall be deemed to have been formed with such Agreement comprised solely of Seller's proposal together with these Terms and Conditions of Sale. The Agreement shall be deemed to supersede any prior written or oral agreements and any different or conflicting terms in any quote, invoice, Buyer purchase order, shipper or any other document. For the avoidance of doubt, any different, additional or conflicting terms provided on any ancillary Buyer document(s) are expressly rejected by Seller.
- D. **MODIFICATIONS/CHANGES/CANCELLATIONS:** Any requested modification to an Agreement is subject to the approval of Seller and the manufacturer or supplier of the goods ordered. Buyer will pay any and all additional charges resulting from order modifications, cancellations, and changes. Express Ship Orders cannot be changed or cancelled. All goods are custom manufactured to customer specifications and, therefore, cannot be returned. Restocking programs are not available. Any modifications of an Agreement must be made via a signed and dated revised proposal.

## 2. CREDIT APPROVAL AND DEPOSITS

All orders are subject to credit approval. A deposit of 50% is required on all orders greater than \$5,000.00. No interest shall accrue on such deposits. Orders less than \$5,000.00 must be paid in full. The Agreement is deemed entered upon such payment by Buyer.

## 3. OWNERSHIP AND RISK OF LOSS

Transfer of title to the goods as between Seller and Buyer shall be deemed to have occurred when the Agreement is entered, and thereafter Buyer shall insure against risk of loss. If the goods are first received on behalf of Buyer by Seller, such goods shall be considered held by Seller subject to bailment for the sole benefit of Buyer.

## 4. PAYMENT

- A. **TIMING:** Any remaining balance on goods purchased under this Agreement and any related installation or other services will be invoiced upon delivery of the goods to the job site or, if installed by Seller, following substantial completion. Direct shipments from manufacturers will be invoiced upon shipment from the manufacturer. Any goods being held at Buyer's request, due to delays or otherwise, will be invoiced for product only upon Seller's receipt of same with separate invoicing for installation or other related services upon substantial completion.
- B. **PAYMENT TERMS:** Seller has the right to increase its prices at any time upon notice to Buyer to reflect any and all unusual or unforeseen increases in Seller cost, provided that any such increase shall be limited to the increase actually incurred by Seller. Buyer will not offset or recoup any claim against amounts due Seller. All invoices are due on the date noted on the related invoice. A monthly service charge of 1.5% (18% A.P.R.) will be assessed on all unpaid balances, including accrued but unpaid monthly service charges, after the invoice due date. A service charge of three percent (3%) of the invoice amount will be added to all invoices paid by credit card.
- C. **FREIGHT:** Buyer is solely responsible for any applicable freight and handling charges, including tariffs, for delivery from the manufacturer to Seller and is FOB origin. If not included in the proposal, such charges are not included in a price quotation and will be invoiced to Buyer separately after the Seller is invoiced by the carrier or manufacturer.
- D. **TAXES:** Buyer is solely responsible for any applicable sales, use, excise, or other taxes. If not included in the proposal, applicable taxes will be invoiced separately. If Buyer possesses tax-exempt status, a certificate of resale, or tax exemption is to be provided prior to order placement.
- E. **DELAYS:** If Buyer is unable or unwilling to receive goods at the prescribed shipping site on the mutually agreed delivery date any goods



## Proposal

Interior Environments - Novi  
48700 Grand River Ave  
Novi, MI 48374  
Phone: (248) 213-3010

Order Number	12145
Date	01/05/2023
Customer PO No	
Customer Name	Livonia Public Schools
Salesperson	Bari Pfeiffer
Terms	NET 30
Page	5 of 6

thereafter stored by Seller will be at Buyer's expense until such time as Buyer is able to accept delivery. Seller shall have no obligation or liability to Buyer whatsoever for failure to ship goods by a particular date.

### 5. DELIVERY AND INSTALLATION

- A. **DELIVERY AND INSTALLATION:** Any contracted delivery and installation will be made during Seller's normal business hours of 7:00 a.m. to 3:30 p.m., Monday through Friday. Overtime delivery or installation performed at the Buyer's request will be subject to labor rates reflecting time-and-a-half for weekdays and double time for weekends and holidays. If applicable trade regulations require employing union tradesmen to complete the installation or delivery, any additional incremental costs will be invoiced to and paid by the Buyer. Seller shall not be liable for failure or delay in installation due to the installation site not being ready for installation. Any shipping, delivery, and performance dates are estimates only, and time is not of the essence. Seller may ship or direct shipments of all the goods at one time or in portions from time to time. Seller has the right, but not the obligation, to determine the method of shipment and routing of the goods, unless otherwise stated in Seller's delivery and installation proposal or acknowledgment.
- B. **SELLER'S RESPONSIBILITIES:** Unless received by Buyer or Buyer's agent directly, Seller will receive, inspect, stage, and if contracted, install Buyer's goods. All furnishings will be left clean and in working order. Carton and packing materials will be removed to the Buyer's waste disposal containers, and the premises will be left broom clean. At Seller's option, Seller may direct shipments directly to the job site.
- C. **BUYER'S ACCEPTANCE:** Buyer agrees to have an agent on the premises at the agreed upon time to accept goods, deliveries, installation, and completed work. All goods and services shall be considered accepted after Buyer or his agent has signed an acknowledgement document(s). All claims or exceptions must be made in writing the date the work is substantially complete. Notwithstanding the foregoing, if Buyer or Buyer's agent is unavailable or unwilling to sign acknowledgment document(s), Buyer shall be deemed to have accepted the goods and services "as is" or as otherwise noted by Seller on the acknowledgement document.
- D. **DROP SHIPMENTS:** In case of drop shipments where goods are delivered without installation, Buyer will receive, inspect, and install ordered goods. Buyer is also responsible for filing necessary freight claims in the event of damage. Buyer shall have no claims against Seller due to damage and may not withhold payment on account thereof.
- E. **CONDITION OF JOB SITE:** Buyer's job site shall be clean, clear of all obstructions, and free of debris prior to any Seller installation. Charges will be assessed to the Buyer for excessive handling, storage and transportation incurred because of site conditions, activity of other trades, or other reasons not specifically identified in the price quotation, at a standard hourly rate, or at actual charges plus fees, if labor is performed by a third party.
- F. **JOB SITE SERVICES:** Buyer will furnish electrical current, heating, lighting, trash disposal containers, hoisting and/or elevator services, and suitable unobstructed dock space and staging areas at the job site without charge to Seller if Seller is to provide installation. If Seller is required to remove or handle existing furniture, the additional cost of moving and transporting shall be billed to the Buyer on an hourly basis. Once installation has begun, Buyer agrees to assume any expense incurred by Seller due to changes made at the Buyer's request or for any reason beyond Seller's reasonable commercial control.
- G. **ELECTRICAL INSTALLATION:** A licensed electrician may be required to install electrical product including outlets, task lights, and hook-ups to base building power. If Seller determines that an electrician is required, Buyer will be responsible for contracting and paying the electrician.
- H. **PROTECTION OF DELIVERED GOODS:** Buyer is responsible for security and safekeeping of goods after delivery to Buyer's site, or into storage negotiated by Buyer if the job site is not ready on an agreed upon delivery date, and Buyer shall assume any risk of damage or loss thereof.
- I. **CONCEALED DAMAGED GOODS:** Buyer is required to report all concealed or damage packaged goods within seven (7) business days or receipt. In addition, Buyer is required to report all damage goods revealed upon unpackaging within seven (7) days of the same. Likewise, Buyer is required to and must send pictures of damaged goods, packages and labels to initiate any available warranty claim(s). Failure to report damages within the required reporting period with the required information may negate any warranty claims and Buyer shall accept responsibility for any and all costs associated with replacement or repairs of damaged goods.

### 6. ADDITIONAL TERMS

- A. **DISCLAIMER OF WARRANTIES: BUYER AGREES THAT THE GOODS ARE OF THE SIZE AND DESIGN SELECTED BY BUYER AND THAT BUYER IS SATISFIED THAT SAME IS SUITABLE FOR BUYER'S PURPOSES. SELLER HAS MADE NO REPRESENTATION**



## Proposal

Interior Environments - Novi  
48700 Grand River Ave  
Novi, MI 48374  
Phone: (248) 213-3010

Order Number	12145
Date	01/05/2023
Customer PO No	
Customer Name	Livonia Public Schools
Salesperson	Bari Pfeiffer
Terms	NET 30
Page	6 of 6

**OR WARRANTY AS TO ANY MATTER WHATSOEVER. SELLER DISCLAIMS AND BUYER EXPRESSLY WAIVES AS TO SELLER, ALL WARRANTIES WITH RESPECT TO THE GOODS, INCLUDING BUT NOT LIMITED TO ALL EXPRESS OR IMPLIED WARRANTIES OF MERCHANTABILITY AND FITNESS FOR A PARTICULAR PURPOSE, QUALITY, CAPACITY, OR WORKMANSHIP. NOTHING CONTAINED HEREIN SHALL DIMINISH THE RIGHT OF BUYER TO EXERCISE ALL RIGHTS AND REMEDIES AGAINST THE MANUFACTURER OF THE GOODS FOR MANUFACTURER WARRANTIES. IN NO EVENT SHALL SELLER BE LIABLE UNDER ANY THEORY AT LAW OR EQUITY FOR ANY LOSS OF USE, REVENUE, ANTICIPATED PROFIT OR SPECIAL, INDIRECT, INCIDENTAL OR CONSEQUENTIAL DAMAGES ARISING OUT OF OR RELATED TO THE DESIGN AND USE OF THE GOODS. SELLER SHALL ADVISE BUYER OF ALL RELATED MANUFACTURERS' WARRANTIES UPON BUYER'S REQUEST.**

- B. **RESALE:** On any resale of the goods, Buyer shall contractually limit its buyer's warranty against both Buyer and Seller to the same extent that Paragraph 6(A) above limits the warranty offered by Seller.
- C. **ACTS BEYOND REASONABLE CONTROL:** Seller shall not be liable for any delay or failure to deliver any or all of the goods caused by installation site delays, labor disputes, strikes, acts of God, or other delays beyond the reasonable control of Seller.
- D. **ASSIGNMENT:** Buyer shall not assign its rights or obligations under this Agreement without the prior written consent of Seller.
- E. **INDEMNIFICATION:** Buyer shall indemnify, defend, and hold harmless Seller with respect to all damages, losses, claims, and expenses, including, without limitation, consequential and incidental damages and reasonable attorney fees arising from or related to : i) Buyer's breach of any of Buyer's obligations under this Agreement and from; ii) Seller's interior design, project management, delivery, installation, or any other services except when caused by Seller's gross negligence or willful misconduct.
- F. **DEFAULT:** If Buyer fails to pay any amount herein provided within ten (10) days after the same is due and payable, or if Buyer fails to observe, keep, or perform any other provision of this Agreement, then Seller shall have the right to exercise any one or more of the following remedies without prejudice to such remedies as may otherwise exist at law or in equity: i) to declare the entire amount due hereunder immediately due and payable without notice or demand to Buyer; ii) to sue for and recover all payments, then accrued or thereafter accruing; iii) to take possession of the goods provided hereunder, without demand or notice wherever located, without any court order or other process of law. Buyer hereby grants free and full access to the premises and hereby waives any and all damages occasioned by such taking of possession.
- G. **NO WAIVER:** Seller's waiver of any right on one occasion shall not be a waiver of any future exercise of that right.
- H. **TIME FOR BRINGING ACTION:** Any action that Buyer brings against Seller that arises out of or relates to the goods and services provided by Seller to Buyer must be brought by Buyer within one year after the cause of action occurs.
- I. **LAW:** The Agreement shall be deemed entered into, and performed in substantial part, in Oakland County, Michigan. The Agreement shall be governed by and construed in accordance with the laws of the State of Michigan, without regard to its conflict of law provisions. The parties hereto agree to submit to the exclusive personal jurisdiction of the state or federal courts serving Oakland County, Michigan for the resolution of any claim or cause of action that arises from or related to this Agreement or the goods or services provided by Seller.

FAMILIAL RELATIONSHIP DISCLOSURE STATEMENT

As required by Public Act 232 of 2004, all bids shall be accompanied by a sworn and notarized statement disclosing any familial relationship that exists between the owner or any employee of the bidder and any member of the Northville Public Schools Board of Education or the Superintendent of Schools. The Board of Education shall not accept a bid that does not include this sworn and notarized disclosure statement.

The undersigned, the owner or authorized officer of Interior Environments (the "Bidder"), pursuant to the familial disclosure requirement provided in the Livonia Public Schools advertisement for construction bids, hereby represent and warrant, except as provided below, that no familial relationships exist between the owner(s) or any employee of the company and any member of the Livonia Public Schools Board of Education or the Superintendent of Schools. If such a relationship exists, please explain:

---

---

---

---

Attach additional pages if necessary

By: Basi Patel (Bidder Signature)  
Title: Account Manager (type or print)  
Date: 12/21/22

Subscribed and Sworn to Before Me:

This 21<sup>st</sup> day of December, 2022 A.D., in and for the  
County of Oakland, Michigan.

My Commission expires 4/22/2026.

[Signature]  
Signature of Notary

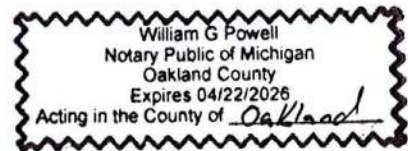



NON-COLLUSION AFFIDAVIT

STATE OF MICHIGAN        )  
                                      )  
WAYNE COUNTY            )        ss:

The undersigned bidder or agent, being duly sworn on oath, says that he/she has not, nor has any other member, representative, or agent of the firm, company, corporation or partnership represented by him/her, entered into any combination, collusion or agreement with any person relative to the price to be bid by anyone at such letting nor to prevent any person from bidding nor to induce anyone to refrain from bidding, and that this bid is made without reference to any other bid and without any agreement, understanding or combination with any other person in reference to such bidding.

He/she further says that no person or persons, firms, or corporation has, have or will receive directly or indirectly, any rebate, gift, fee, commission or thing of value on account of such sale.

Interior Environments  
\_\_\_\_\_  
Bidder (Firm)  
*Bari Patel*  
\_\_\_\_\_  
Signature of Bidder or Agent

Subscribed and sworn to before me this 21<sup>st</sup> day of December, 2022.

My commission expires: 04/22/2026

County of residence: Oakland

*[Signature]*  
\_\_\_\_\_  
Notary Public Signature

Seal



CERTIFICATION OF COMPLIANCE – IRAN ECONOMIC SANCTIONS ACT  
Michigan Public Act No. 517 of 2012

The undersigned, the owner, or authorized officer of the below-named company (the "Company"), pursuant to the compliance certification requirement provided in the Livonia Public Schools Request For Proposal (the "RFP"), hereby certifies, represents, and warrants that the Company (which includes its officers, directors and employees) is not an "Iran Linked Business" within the meaning of the Iran Economic Sanctions Act, Michigan Public Act No. 517 of 2012 (the "Act"), and that in the event the Company is awarded a contract by the Livonia Public Schools Board of Education as a result of the aforementioned RFP, the Company is not and will not become an "Iran Linked Business" at any time during the course of performing any services under the contract.

The Company further acknowledges that any person who is found to have submitted a false certification is responsible for a civil penalty of not more than \$250,000.00 or two (2) times the amount of the contract or proposed contract for which the false certification was made, whichever is greater, the cost of the Livonia Public Schools' investigation, and reasonable attorney fees, in addition to the fine. Moreover, any person who submitted a false certification shall be ineligible to bid on a request for proposal for three (3) years from the date that it is determined that the person has submitted the false certification.

Interior Environments

Name of Company

Bari Pfeiffer, Account Manager

Name and Title of Authorized Representative

Bari Pfeiffer  
Signature

12-21-22

Date

\*\*END OF SECTION\*\*



Wenger Corporation  
 555 Park Drive  
 Owatonna, MN 55060-4940  
 United States



Phone: 507-455-4100  
 Fax: 507-455-4258

**Quote Number: 3262783**

Stagetek Audience Seating OMNIA updated  
 12.12.2022

**QUOTE**

Date: 12/12/2022  
 Page: 1 of 3  
 Cust #: 00137299

<p><b>Quote To:</b></p> <p>Livonia Career &amp; Technical Ctr        8985 Newburgh Rd        Livonia MI 48150-3497        United States</p> <p><b>Phone:</b>  <b>Fax:</b>  <b>E-Mail:</b></p>	<p><b>Date:</b> 12/12/2022  <b>Expires:</b> 2/24/2023  <b>Reference:</b>  <b>Terms:</b> Net 30 Days  <b>Created By:</b> Christy Mullerleile</p> <p><b>Salesperson:</b> Theresa Bartok  <b>Phone:</b> +1 (507) 774-8527  <b>E-Mail:</b> Theresa.Bartok@wengercorp.com</p>
---	--

**Quote Comments:**

*Since the pandemic, significant supply chain issues have been creating disruption across many industries globally. At Wenger Corporation, our purchasing team is working with our suppliers to mitigate the impact of the disruptions.*

*Unfortunately, we are facing shortages in key areas such as steel, plastic and wood resulting in delays in meeting our customers' orders/timelines.*

*Freight quoted is for a one time shipment. As a result, once orders are placed, delivery dates may change.*

**\*\*\*PLEASE NOTE: Customer requested split shipments will result in an additional freight charge.\*\*\***

*We apologize for any inconvenience this may cause. We value your business and thank you for your patience during these unusual circumstances.*

*Customer to verify all items on this quote before placing order*

*\* Wenger is an approved vendor for Region 4 ESC/OMNIA Partners, Public Sector. All items on this quotation are available through Contract #R191204. This contract is in effect through 10/31/2023.*

Line	PartNum/Description	Qty	Net Price	Ext. Price
1.00	280A200.112 StageTek Rectangular Deck Cracked Ice 3'x8',Center Brace	8 EA	\$774.00	\$6,192.00
2.00	280B100.136 StageTek Fixed Leg 32" Elevation	16 EA	\$18.00	\$288.00
3.00	280B100.123 StageTek Fixed Leg 16" Elevation	32 EA	\$12.00	\$384.00
4.00	281A340 STAGETEK,CONNECT,2 LEG,RECT	14 EA	\$28.00	\$392.00
5.00	281A600 LEG STORAGE CLIP,4 PK	12 EA	\$16.00	\$192.00

USD

Wenger Corporation  
555 Park Drive  
Owatonna, MN 55060-4940  
United States



Phone: 507-455-4100  
Fax: 507-455-4258

Quote Number: 3262783

Stagetek Audience Seating OMNIA updated  
12.12.2022

**QUOTE**

Date: 12/12/2022  
Page: 2 of 3  
Cust #: 00137299

Item #	Description	Quantity	Unit Price	Total Price
6.00	281C404.127 StageTek Standard Guardrail 8'	4 EA	\$266.00	\$1,064.00
7.00	281C404.118 StageTek Standard Guardrail 3'	2 EA	\$194.00	\$388.00
8.00	113K001 Staging Universal Deck & Rail Cart	3 EA	\$672.00	\$2,016.00
9.00	281A304 LEG STRAP,45",2 PK	8 EA	\$0.00	\$0.00
10.00	281A100 StageTek 2-Step Stairway 16/24" With Rail	1 EA	\$475.00	\$475.00
11.00	Freight Freight Services	1 EA	\$2,216.19	\$2,216.19
12.00	Install Installation Services	1 EA	\$1,866.94	\$1,866.94

*INSTALLATION WITH INSIDE DELIVERY*

*\*\*\*\*\*MAIN FLOOR INSTALL ONLY\*\*\*\*\**

*This pricing includes complete delivery and installation, which includes unloading, assembling and removal of debris by Wenger-trained technicians, at non-prevailing, non-union wage rates, to 1st floor locations.*

*2nd floor or greater may incur additional fees. Check with your representative for further details.*

*NOTE: \*\*\*\* At time of order please provide COVID protocol requirements and any campus safety/security requirements and directions for compliance. \*\*\*\**

*Notwithstanding anything to the contrary in this agreement, Wenger shall not be liable for delay or non-performance caused by any of the following circumstances when beyond its control: acts of God, explosions, riots, labor disputes (provided Wenger has exercised reasonable commercial efforts to avoid it), failures of utilities or public services, civil unrest, foreign or domestic governmental regulation or order, public health emergencies, natural disasters, cyber-attacks, wars, acts of foreign enemies, sabotage, or terrorism, including sub-supplier delays caused by any of the above provided the same are not caused or contributed to by the negligence or fault of Wenger ("Force Majeure").*

*If you are a tax-exempt organization and quote includes tax, please send a copy of your tax-exempt certificate and we will remove the sales tax. Thank you*

*Note: The pricing shown above includes complete delivery, unloading, assembly, installation, and removal of debris by Wenger trained technicians.*

FAMILIAL RELATIONSHIP DISCLOSURE STATEMENT

As required by Public Act 232 of 2004, all bids shall be accompanied by a sworn and notarized statement disclosing any familial relationship that exists between the owner or any employee of the bidder and any member of the Northville Public Schools Board of Education or the Superintendent of Schools. The Board of Education shall not accept a bid that does not include this sworn and notarized disclosure statement.

The undersigned, the owner or authorized officer of Wenger Corporation (the "Bidder"), pursuant to the familial disclosure requirement provided in the Livonia Public Schools advertisement for construction bids, hereby represent and warrant, except as provided below, that no familial relationships exist between the owner(s) or any employee of the company and any member of the Livonia Public Schools Board of Education or the Superintendent of Schools. If such a relationship exists, please explain:

None  
\_\_\_\_\_  
\_\_\_\_\_  
\_\_\_\_\_

Attach additional pages if necessary

By: \_\_\_\_\_ (Bidder Signature)  
Title: Theresa Bartok, Senior Acquisitions Sales Representative (type or print)  
Date: December 21, 2022

Subscribed and Sworn to Before Me:

This 21st day of December, 2022 A.D., in and for the  
County of Steele, ~~Michigan~~ Minnesota  
My Commission expires January 31, 2025.

Lola Ann McDermott  
\_\_\_\_\_  
Signature of Notary

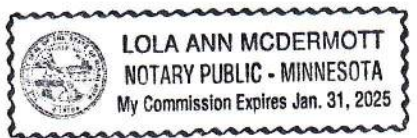

NON-COLLUSION AFFIDAVIT

Minnesota

STATE OF ~~MICHIGAN~~ )  
Steele ) ss:  
~~WAYNE~~ COUNTY )

The undersigned bidder or agent, being duly sworn on oath, says that he/she has not, nor has any other member, representative, or agent of the firm, company, corporation or partnership represented by him/her, entered into any combination, collusion or agreement with any person relative to the price to be bid by anyone at such letting nor to prevent any person from bidding nor to induce anyone to refrain from bidding, and that this bid is made without reference to any other bid and without any agreement, understanding or combination with any other person in reference to such bidding.

He/she further says that no person or persons, firms, or corporation has, have or will receive directly or indirectly, any rebate, gift, fee, commission or thing of value on account of such sale.

Wenger Corporation

Bidder (Firm)

Theresa Bartok

Signature of Bidder or Agent

Theresa Bartok, Senior Acquisitions Sales Representative

Subscribed and sworn to before me this 21st day of December, 2022.

My commission expires: January 31, 2025

County of residence: Steele

Lola Ann McDermott

Notary Public Signature

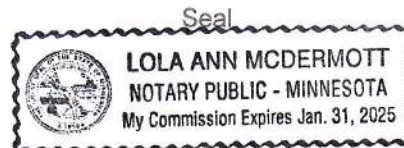



CERTIFICATION OF COMPLIANCE – IRAN ECONOMIC SANCTIONS ACT  
Michigan Public Act No. 517 of 2012

The undersigned, the owner, or authorized officer of the below-named company (the "Company"), pursuant to the compliance certification requirement provided in the Livonia Public Schools Request For Proposal (the "RFP"), hereby certifies, represents, and warrants that the Company (which includes its officers, directors and employees) is not an "Iran Linked Business" within the meaning of the Iran Economic Sanctions Act, Michigan Public Act No. 517 of 2012 (the "Act"), and that in the event the Company is awarded a contract by the Livonia Public Schools Board of Education as a result of the aforementioned RFP, the Company is not and will not become an "Iran Linked Business" at any time during the course of performing any services under the contract.

The Company further acknowledges that any person who is found to have submitted a false certification is responsible for a civil penalty of not more than \$250,000.00 or two (2) times the amount of the contract or proposed contract for which the false certification was made, whichever is greater, the cost of the Livonia Public Schools' investigation, and reasonable attorney fees, in addition to the fine. Moreover, any person who submitted a false certification shall be ineligible to bid on a request for proposal for three (3) years from the date that it is determined that the person has submitted the false certification.

Wenger Corporation

Name of Company

Theresa Bartok, Senior Acquisitions Sales Representative

Name and Title of Authorized Representative

*Theresa Bartok*

Signature

December 21, 2022

Date

\*\*END OF SECTION\*\*

Wenger Corporation  
555 Park Drive  
Owatonna, MN 55060-4940  
United States



Phone: 507-455-4100  
Fax: 507-455-4258

**Quote Number: 3262783**

Stagetek Audience Seating OMNIA updated  
12.12.2022

**QUOTE**

Date: 12/12/2022  
Page: 3 of 3  
Cust #: 00137299

---

Lines Total	\$15,474.13
Total Taxes	\$683.46

<b>Quote Total</b>	<b>\$16,157.59</b>
--------------------	--------------------



**MUSIC EDUCATION AND PERFORMING ARTS**

Owatonna Office: Phone 800.4WENGER (493-6437) Worldwide +1.507.455.4100 | Parts & Service 800.887.7145 | wengercorp.com | 555 Park Drive, PO Box 448 | Owatonna | MN 55060-0448

Syracuse Office: Phone 800.836.1885 Worldwide +1.315.451.3440 | jrclancy.com | 7041 Interstate Island Road | Syracuse | NY 13209-9713

**ATHLETICS** Phone 800.493.6437 | email gearboss@wengercorp.com | gearboss.com | 555 Park Drive, PO Box 448 | Owatonna | MN 55060-0448