

**Monaghan Estates**  
**Tax Parcel #H-0000-024-1600 &**  
**H-0450-24-103-AB**  
**Owner: Aspen Homes and Development LLC**  
**Case No. PZE-26-0035**

**Contents**

SUMMARY OF REQUEST ..... 1  
 LOCATION ..... 2  
 LEGAL DESCRIPTION ..... 2  
 ANALYSIS ..... 2  
 ADDITIONAL INFORMATION ..... 9  
 STAFF RECOMMENDED CONDITIONS OF APPROVAL ..... 9

**SUMMARY OF REQUEST**

The applicant, Olson Engineering, Inc., on behalf of the owners, Aspen Homes and Development, LLC, is requesting the approval of a major subdivision of two parcels into 20 single-family residential lots. The parcels are 7.01 acres and 1.66 acres, respectively, totaling 8.67 acres. The property is zoned Single-Family Residential (R1) and is currently residential with customary accessory structures and vacant land. The following demolition permits PB25-0578 and PB25-0579 have been issued, PB25-0580, PB25-0581, & PB25-0582 are ready to issue for the various structures on the site.

In the review of the structures (constructed between 1949 and 1961) to be demolished, the Historic Preservation Commission identified the general location as having historical significance to the city. The roads of 4<sup>th</sup> Street, Honeysuckle Avenue, and Strahorn Road connected the City of Coeur d'Alene to the Hayden Lake Country Club via train. These roads are built upon old railroad locations. Additionally, the railroad picked up logs from the mill south of Honeysuckle Beach,



and fruit from the packing plant near this site north of Honeysuckle Avenue. The property immediately southeast of project site was a part of the estate area known as Clarksville encompassing Clark Point and the Clark Estate with their main entrance accessed from Honeysuckle Avenue to Lower Hayden Lake Road. The Historic Commission asked the owner to consider a location for an interpretative sign to be placed north of the multi-modal pathway to educate the public on the importance of this historical area to the community.

## LOCATION

The subject site is located North of East Honeysuckle Avenue and North 4<sup>th</sup> Street, more commonly known as 751 E Honeysuckle Avenue.

## LEGAL DESCRIPTION

Parcel 1: Portion of Tax #14100 Except right of way (Inside Hayden Lake Watershed Boundary) and Tax #14691 Except right of way in Section 24, Township 51 North, Range 04 West containing 7.01 acres.

Parcel 2: Avondale, Portion of Tax #14100 Except right of way in Tract 103, Section 24, Township 51 North, Range 04 West; containing 1.66 acres.

## ANALYSIS

The analysis is organized following the general standards 1 through 8 of the Hayden City Code §12-3-4, which can be found in their entirety in the Appendix. Those items of the analysis, which are required of all subdivisions, shall be found in the Appendix and made a part of this staff analysis. Those items, which are more site specific, shall be identified in the analysis provided here.

1. Infrastructure *can/cannot be* constructed to function in a manner that promotes the public health, safety, and welfare.
2. Infrastructure *can/cannot be* constructed and located in an orderly manner that accommodates ongoing maintenance needs when taking into consideration collocation of other infrastructure.

*Standard #1 & #2 may be addressed throughout the remainder of the staff analysis and the applicant's narrative.*

3. Infrastructure *is/is not or will/will not be* in compliance with applicable city, state, and federal policies and regulations as follows:
  - a) Provisions *have/have not* been made for a water supply system that satisfies city, Idaho Department of Environmental Quality (IDEQ) and Northern Lakes Fire Protection District requirements.
  - b) Provisions *have/have not* been made for a public sewage system in accordance with the City and Hayden Area Regional Sewer Board's (HARSB) adopted sewer master plans, as amended, that satisfied City, HARSB, and IDEQ requirements and that the existing or proposed systems can accommodate the proposed sewer flows.
  - c) Provisions *have/have not* been made for snow storage that satisfies the City Public Works Department as the design relates to snow storage and removal practices. If snow storage is proposed to be co-located with storm water, it shall only be in roadside swale areas and not in regional detention basins unless approved administratively by the City engineer who shall determine that the likelihood of flooding is minimal.
  - d) Provisions *have/have not* been made for storm water systems that satisfy the city and IDEQ requirements.

- e) Provisions *have/have not* been made for streets that are consistent with the adopted transportation plan, as amended, and the transportation element of the adopted comprehensive plan, as amended, and that satisfies the city, ITD, adjacent jurisdictions, and local highway district requirements. Where cul-de-sacs are proposed, they are required to be approved administratively by the City engineer who shall determine that they are limited to portions of developments in which street continuity is not foreseeable due to property configurations and /or that they are needed to address site-specific conditions. A cul-de-sac shall be limited to 400' in length measured from the edge of adjacent street right-of-way to the back of the cul-de-sac, unless an exception to this standard is allowed by the City Engineer.
- f) Provisions *have/have not* been made for parks and open space that are consistent with the adopted parks master plan, as amended, and that satisfies the city's requirement

**Potable Water and Fire-flow:**

The subject property is located within the Avondale Irrigation District (AID). The Developer has submitted a Conditional Will Serve letter from AID, dated March 23, 2026. The Developer shall be required to provide all dedications and easements, and construct appurtenances as may be required by the water district at the time of development.

The subject property is located within the Northern Lakes Fire Protection District (NLFPD). As a part of the subdivision construction, the property owner shall install fire hydrants and construct all infrastructures, which shall be designed and located as required by the Northern Lakes Fire Protection District and Avondale Irrigation District. As of the date of this analysis, NLFPD has not provided agency comments related to this project. Should comments and/or conditions be received prior to the public hearing, those will be entered into the file for the hearing body's consideration.

**City Collection System:**

Alan Soderling, PE, City of Hayden Public Works Director, provided a Will Serve letter for City sewer on dated March 13, 2026, as required by Hayden City Code §12-3-4(A) (10). Per the Will Serve Letter provided by Mr. Soderling, the project site is within the H-1 sewer basin of the City's sewer plans. "It is the intent and willingness of the City of Hayden to serve and treat sewer for the property described in this letter. However, this service is limited based on capacity available at the time of connection in the City's collector sewer lines [in the H-1 Basin] and capacity for treatment at the Hayden Area Regional Sewer Board's treatment facility. Please be advised that the City of Hayden has no singular jurisdictional authority over treatment and capacity at the sewer treatment plan and therefore cannot independently or expressly authorize expansion, enlargement, or extension of the facility, should capacity at the treatment plant be reached at the time of connection."

At the time of future development, the developer shall be required to construct all sewer infrastructures in conformance with the 2020 Collection System Master Plan Update, State law, and all City sewer policies, standards and technical memos. Per the City's adopted sewer policies, no cross-country sewer shall be allowed. The preliminary plat provided an overall sewer layout. Changes to configurations of sewer and/or streets may be required, which may require an amendment to the preliminary plat in accordance with the Hayden City Code. The Developer shall be required to reflect all necessary sewer easements on the face of the final plat of the subdivision.

**HARSB Treatment Plant:**

The subject property is located within the service area of the Hayden Area Regional Sewer Board (HARSB). Will serve letters are provided by the City of Hayden and not generally received from HARSB.

**Streets, Pedestrian Paths, and Right-of-Ways:**

**Transportation Impact Analysis (TIA):**

Hayden adopted a Transportation Analysis Process, Requirements, and Guidelines in December of 2020. In section 2.1 Requirements, the policy identifies when a TIA shall be prepared, unless waved by the City Engineer.

A trip generation letter provided by Steve Soltys, Olson Engineering, identified what the peak hour trip generation and the average daily trip generation is expected to be for this project site of 20 single family lots based on the ITE Trip Generation Manual.

When a TIA is required	Information provided per request
When the peak hour trip generation is expected to exceed 75 vehicle trip ends from the proposed development	23 Peak Trips Expected – Does not exceed
When the average daily trip (ADT) generation is expected to exceed 500 trips from the proposed development	230 ADT Expected – Does not exceed
When the proposed development changes the currently accepted Comprehensive Plan land use assumptions	No change in Comprehensive Plan Requested

Therefore, no Transportation Impact Analysis was required for this project.

**Required Street Construction:**

The proposed internal streets shall be contained within the boundaries of the subject lot and shall connect to the extension of N Secretariat Lane to the north and via an east-west road named “Road A” intersect with East Honeysuckle to the south. These local streets shall be constructed to an ST-111 and ST-111A typical section. The proposed extension of N Secretariat Lane includes landscape medians, with additional right-of-way. The HOA shall maintain the landscape medians. “Road A” shall have adequate turnaround easements and asphalt to meet snow removal and fire requirements.

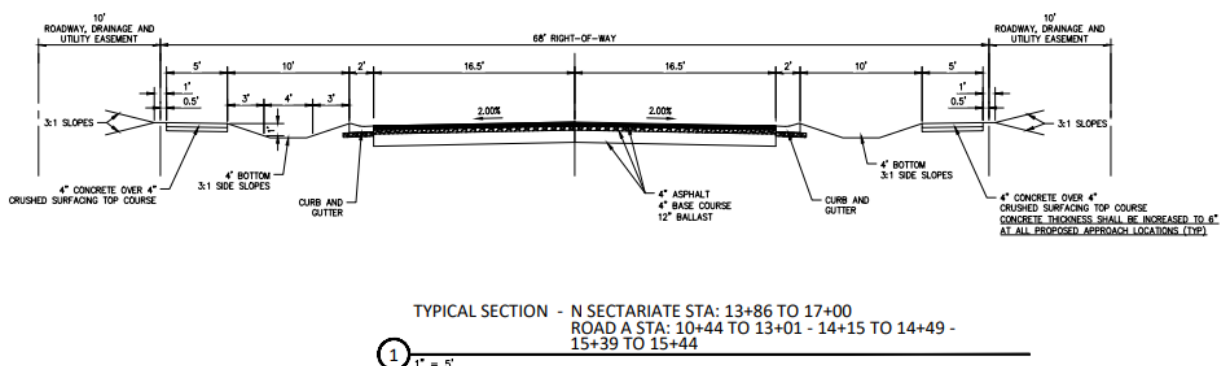

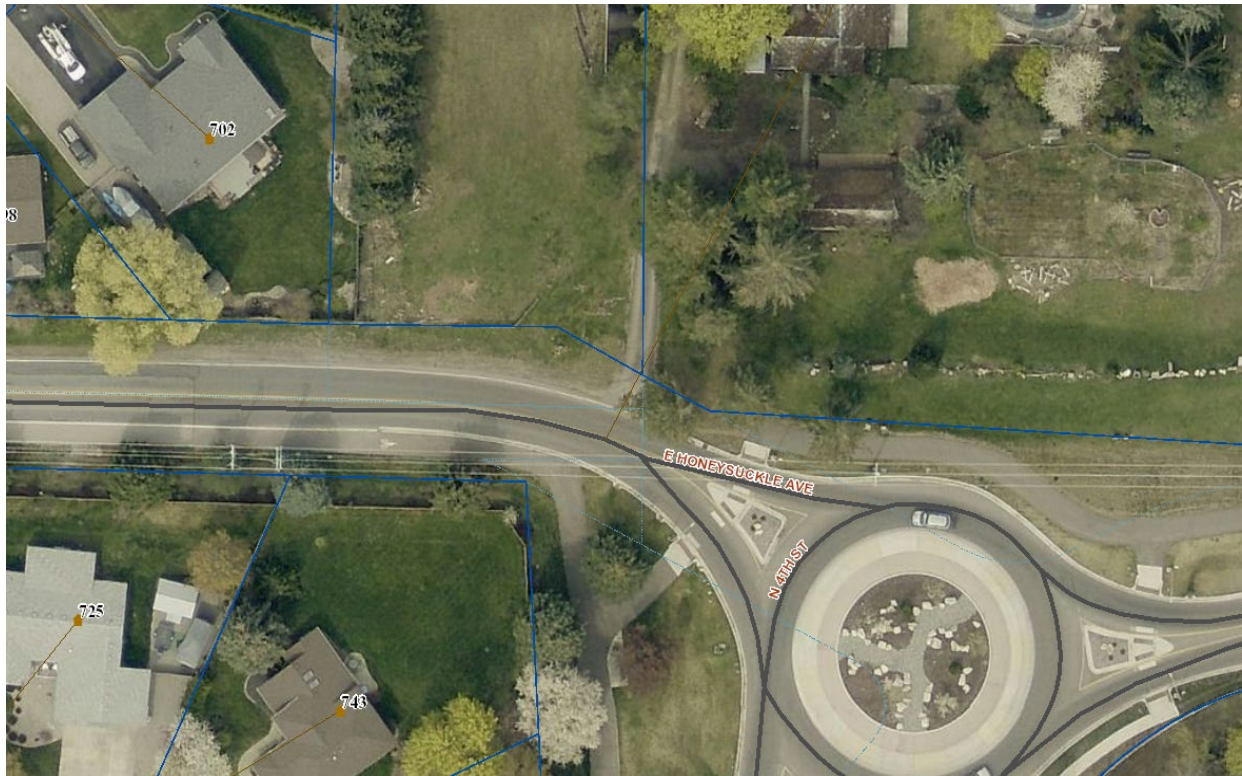

**Honeysuckle Avenue:**

Honeysuckle Avenue road frontage improvements for most of the project site were constructed with the roundabout as shown above. For that area west of the roundabout for the project site, the remaining road frontage and future intersection improvements of “Road A” and Honeysuckle Avenue shall be constructed in accordance with the requirements as identified for the transition from the roundabout to the modified typical section of Honeysuckle Avenue as shown below. “Road A” will be a right-in, right-out median-controlled intersection. All roadways shall be constructed to the City of Hayden Code, Policies, and Plans.

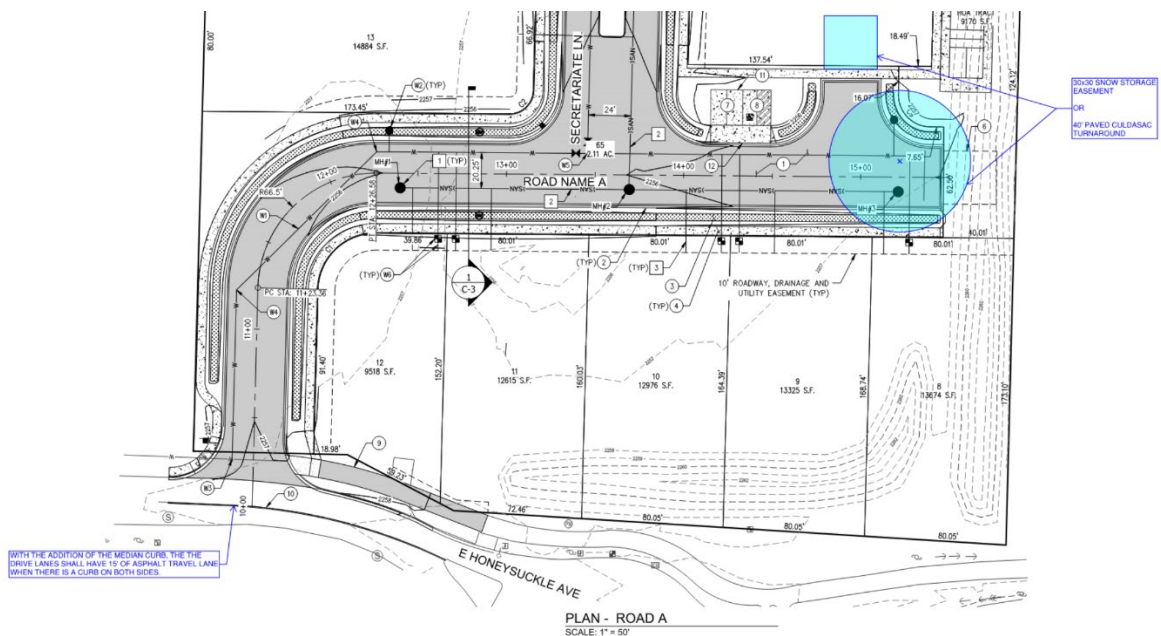

### Multi-Modal Connections:

Both the 2040 Transportation Strategic Plan (In 8.2.1 and 8.2.2) and the 2040 Parks Plan identify when a multi-modal transportation connection is important. As shown to the right, the Master Plan of the 2040 Parks Plan identifies a trail system along East Honeysuckle Avenue. The 2040 Transportation Strategic Plan also identifies Honeysuckle Avenue in this area to have a Class I separated multi-use path. Under 8.2.2 Bicycle and Pedestrian Improvements, the identified customer bases include: recreational users, commuters, students and exercise enthusiasts. Well defined neighborhoods, parks, schools, shopping centers,

Parks Master Plan: Identifying greenway extensions, linkages, & proposed future parks

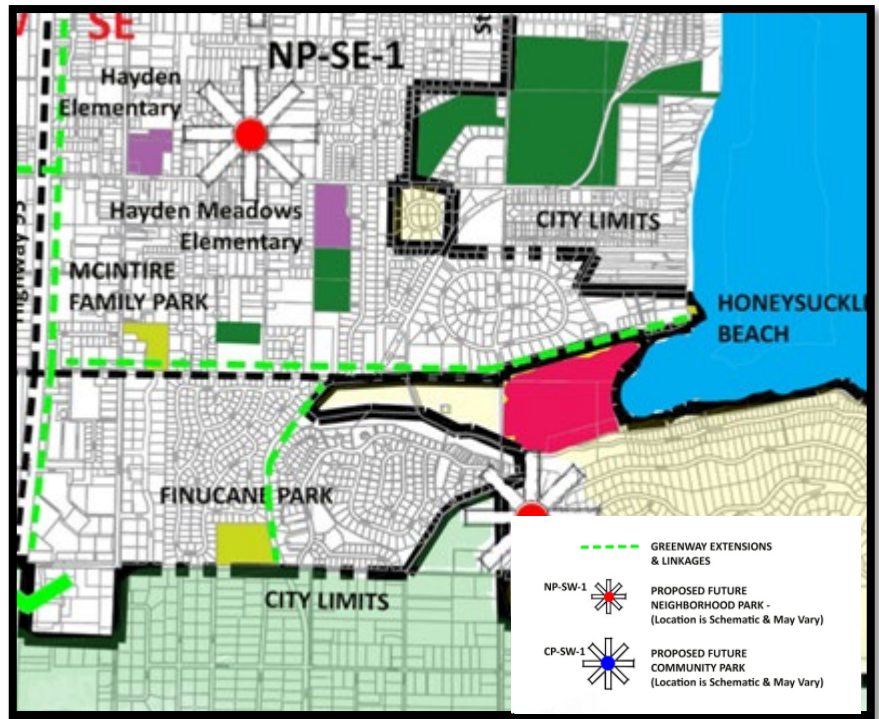

connection points to adjacent community networks, recreational destinations, and connections to regional bus routes are all reviewed and included when looking at where to place the multi-modal pathways. Therefore, the continuation of the multi-modal pathway on the north side of East Honeysuckle Avenue shall be included as a condition of subdivision approval instead of the typical sidewalk that will be seen on the internal road network.

### Landscaping:

Landscaping associated with the multi-modal Class I separated path identified by the transportation plan (Figure 8.2), or the Greenways identified by the parks plan above, shall be a requirement of the construction plans and required as a condition of acceptance of infrastructure.

No additional parkland is required of the project; however, the project proposes to also include landscape medians along Secretariat Lane and provide HOA space. Homes in this subdivision shall pay impact fees in accordance with the adopted fee schedule at the time of building permit issuance.

The construction plans shall include landscape plans for the required street frontage improvements in conformance with Hayden City Code and shall be reviewed at the time of construction plan submittal. Irrigation, grass, and trees shall be placed at the time of the building permit for each of the lots within the subdivision according to the approved landscape plans.

4. Provisions *have/have not* been made for erosion controls and geo-hazards stabilization both during construction and as needed for permanent controls to the satisfaction of the city.
5. Provisions *have/have not* been made for gas, power, telecommunications, mailboxes, and similar infrastructure.

- Provisions *have/have not* been made for driveway locations that take into consideration the width and location of the driveway in relation to the location of snow storage, utility boxes, crosswalks, adjacent roads, mailboxes and the like.

All parcels shall be accessed from the roads within the interior of the subdivision. No individual access (primary or secondary) shall be to Honeysuckle Avenue.

The mailbox locations shall be on the internal public street due to traffic conflict concerns on Honeysuckle Avenue.

- The area proposed for subdivision *is/is not* zoned for the proposed use and the use conforms to other requirements found in this code.

**Zoning:**

**Hayden City Code §11-2-2:**

The Single-Family Residential (R-1) Zone provides for the classic Hayden neighborhood where single family homes on smaller lots are permitted. Accessory dwelling units are permitted, but two-family dwellings are not. All lot development shall be in accordance with Hayden City Code at the time of building permit issuance.

**Surrounding Zoning Map and Comprehensive Plan Land Uses:**

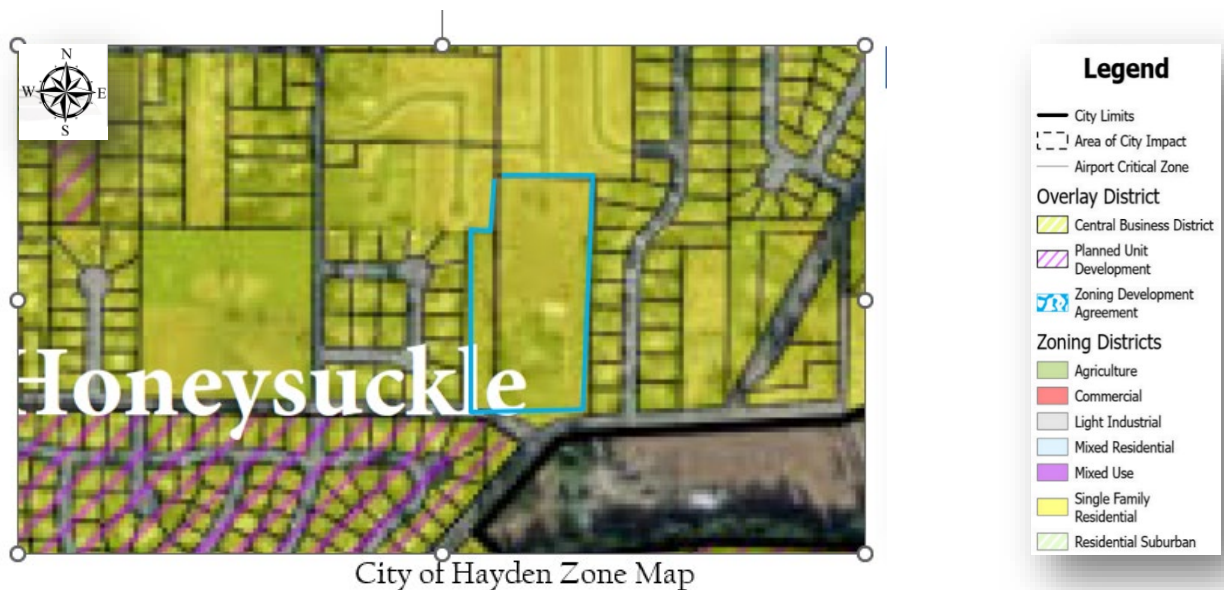

**Zoning Map (shown above):**

Properties to the west, north and east have a Single Family Residential (R1) zone designation. Property to the southwest and further to the southeast is within a Planned Unit Development with a single-family residential underlying zone designation. Property immediately to the southeast is in unincorporated Kootenai County and has an Agricultural-Suburban zone designation respectively.

**Surrounding Current Land Uses:** The properties to the north, east and west and southwest are residential uses and southeast is residential and farm land.

Hayden City Code Title 12 Subdivisions identifies the provisions are adopted to provide for the orderly division of land within the city, and to guide the future growth and development of the city in accordance with the comprehensive plan in addition to encourage, guide the design and construction of infrastructure, and protect and provide for the public health, safety, and general welfare of Hayden.

**Comprehensive Plan Land Use Map Designations (shown to the right):** The project property is shown as Residential. A Residential land use allows for lots of varying sizes designed for people to live. Housing design may vary between and through residential areas.

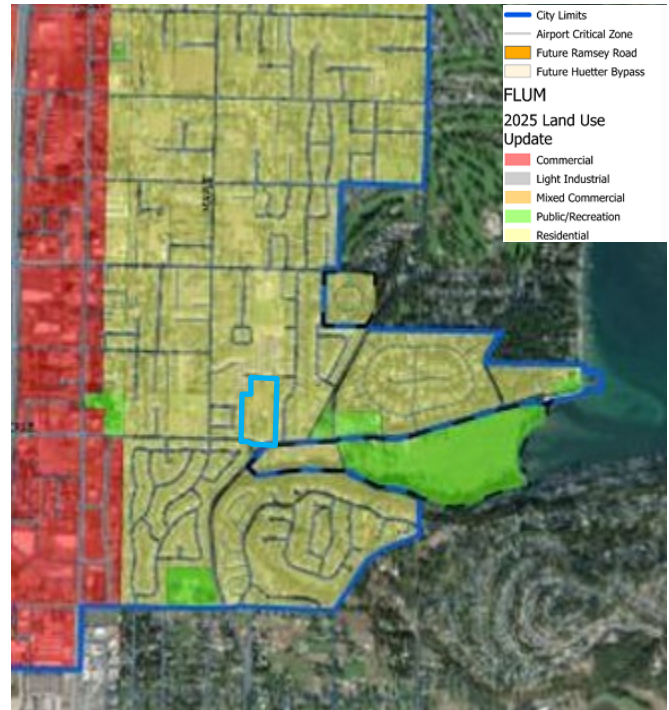

The vision of the City is as follows:

Hayden is a well-managed Idaho town that prioritizes responsible growth and mature infrastructure planning practices to provide a variety of housing options, to encourage small business development, and to protect its natural resources.

Goals are broad, community supported statements that express long-term aspirations based on public input and regional coordination.

Policies are clear guidelines that reflect community values and direct decision-making on land use, infrastructure, and public investment.

The Goals and Policies may be found in the Appendix. Goals that could be considered would be related to the following topics:

- Protecting and strengthening existing neighborhoods
- Implement adequate parks and open leisure space to compliment the associated neighborhood.
- Ensure infrastructure development costs are shared equitably
- Develop land within the City prior to annexation of adjacent lands
- Promote non-motorized connectivity

Policies that could be considered would be related to the following topics:

- Development will be compatible with the land use chapter of the Comprehensive Plan and fiscally responsible in supplying adequate transportation, utilities, and parks to rely developed areas
- Variety of cohesive housing options will be encouraged when considering infill projects
- Parks, leisure or natural space will be incorporated into all future housing development projects.
- Infrastructure will be evaluated based on its impact to public facilities, utility services and existing City resources.

- Establish non-vehicular pathways to promote access to neighborhood parks.
- Land use decisions will consider the preservation of historical structures.
- Protect lives and property from environmental and man-made risks and hazards.

8. The developer has made adequate plans to ensure that the community will bear no more than its fair share of costs to provide services by paying fees, furnishing land, or providing other mitigation measures for off-site impacts to streets, parks, and other public facilities within the community. It is the expectation that in most cases, off-site improvements will be dealt with through the agreements.

All on-site and off-site improvements shall be required of the Developer per the adopted City codes, standards, and plans.

## ADDITIONAL INFORMATION

### Notice and Comments

In response to the request for comment from 21 agencies on April 14, 2026, the following agencies provided the responses identified below in summary and attached in full:

#### Agency Comments:

1. On April 14, 2026, Avondale Irrigation District responded that a Will Serve had been provided and that no further comments were required.
2. On April 15, 2026, Idaho Transportation Department responded with no comments.
3. On April 16, 2026, Panhandle Health District responded with a request for a complete subdivision application and requirements met prior to final plat.
4. On April 16, 2026, Kootenai County Sheriff's Office responded with "no issues or concerns at this time."
5. On April 17, 2026, Idaho Department of Water Resources responded the project site would be served by Avondale Irrigation District and had no concerns with the proposal. They did notate that North Kootenai may be able to serve the property as well.
6. On April 30, 2026, Idaho Department of Fish and Game comments with "does not have any comments to submit for this project".

**Public Comments:** There were no public comments received at the time of completion of the staff review.

## STAFF RECOMMENDED CONDITIONS OF APPROVAL

### General Conditions of Approval:

1. The Developer shall be required to reflect all necessary permanent dedications and/or easements (to include but not be limited to avigation, sewer, stormwater, water, utilities, etc.) on the face of the final plat of the subdivision and to record as a separate document all necessary temporary easements and to identify to whom the dedication and/or easement is to be granted and for what purpose.
2. All permits from outside agencies (ie. CDA Airport, HARSB, AID, IDEQ, NLFPD, and PHD) shall be obtained prior to construction of any future development or building permit issuance.

3. This approval shall run with the land for the term approved herein regardless of whether the property ownership, applicant and/or design professionals noted herein remain the same, whether collectively or individually.
4. Home Owners Association (HOA) documents and legal instrument providing a mechanism for funding shall be required prior to the recordation of the final plat to maintain the open space and landscaping island areas to be owned or maintained by the HOA.
5. Deeds for transfer of ownership of property to become owned by the home owners' association shall be provided to the City in the form acceptable to the City at the completion of any required infrastructure to be recorded concurrent with the final plat free of all liens and encumbrances.

**Access Conditions of Approval:**

6. All lots shall be accessed from the internal roads of the subdivision. No lot shall have any form (primary, secondary, for accessory buildings, etc.) of direct individual access onto Honeysuckle Avenue. The final location of all driveways shall be subject to the review and approval of the City. Particular attention will be paid to location of utility pedestals in relation to driveway and snow storage needs and to those lots at intersections to avoid conflict with the required traffic flow.

**Construction Plan Requirements:**

7. The construction plan submittal shall include those requirements as identified in Hayden City Code §12-6 and more specifically as follows:
  - a. The Developer shall use the City of Hayden Sanitary Sewer system to serve future development in accordance with the adopted Sewer Master Plan. No cross country sewer alignments are allowed.
  - b. No USPS mailboxes shall be allowed on Honeysuckle Avenue. A letter (e-mail) from the US Postal Service with respect to mailbox locations shall be provided, with the intent to place the mailboxes within the subdivision on the internal streets.
8. Landscape Plans: Detailed landscaping plans conforming to the requirements of City Code, shall be submitted for the entire development with construction plans for required subdivision improvements for review and approval by the City. All disturbed areas shall be stabilized with dryland grass or other approved BMP.
  - a. Individual Lots: The landscape plans shall include a dryland grass mix and shall be applied until individual lots are constructed and the hydro-seeding, installation of the irrigation system and required landscaping are completed.
  - b. Street Frontage: Along all street frontages shall be included within the landscaping plan submittal, with actual street tree placement to be completed at the time of building permit for all lots on the internal streets, with the exception of landscaping required with the open space tracts to be owned by the homeowner's association, and/or multi-modal pathways and the associated landscaping.
  - c. Multi-modal Class I pathway: Shall be a requirement of the construction plans and required as a condition of acceptance of infrastructure in accordance with the design standards of the adopted Transportation Plan and/or Park Master Plan.
  - d. Open Space Tract(s): Shall be a requirement of the construction plans and required construction of the subdivision to be completed prior to final plat.
9. A historical interpretative sign structure shall be constructed in accordance with the adopted sign structure type with the sign content to be provided by the City Historical Preservation Commission

and the sign shall not be placed within the City's right-of-way, but shall be placed within a dedicated easement or tract.

**Requirements requested by other Agencies:**

10. The Developer shall comply with the requirements from the Northern Lakes Fire Protection District.
11. The aviation easement requested by the Coeur d'Alene Airport shall be recorded and shall be referenced on all final plats of the subdivision.

# Appendix

## APPENDIX SUBDIVISION (MAJOR)

STANDARDS FOR SUBDIVISION APPROVAL .....	1
POTABLE WATER AND FIRE-FLOW .....	8
SEWER - CITY AND HARSB .....	8
STORMWATER .....	9
STREETS, PEDESTRIAN PATHS, AND RIGHT-OF-WAYS .....	9
EROSION CONTROLS AND GEO-HAZARD STABILIZATION .....	11
GAS, POWER, TELECOMMUNICATIONS, MAILBOXES .....	11
DRIVEWAY LOCATIONS.....	11
COMPREHENSIVE PLAN GOALS and POLICIES .....	11

### STANDARDS FOR SUBDIVISION APPROVAL

#### Idaho State Law

1. As per Idaho Code § 67-6513 Each governing board shall provide, by ordinance adopted, amended, or repealed in accordance with the notice and hearing procedures provided under section [67-6509](#), Idaho Code, for standards and for the processing of applications for subdivision permits under sections [50-1301](#) through [50-1329](#), Idaho Code. Each such ordinance may provide for mitigation of the effects of subdivision development on the ability of political subdivisions of the state, including school districts, to deliver services without compromising quality of service delivery to current residents or imposing substantial additional costs upon current residents to accommodate the proposed subdivision. Fees established for purposes of mitigating the financial impacts of development must comply with the provisions of [chapter 82, title 67](#), Idaho Code. Denial of a subdivision permit or approval of a subdivision permit with conditions unacceptable to the landowner may be subject to the regulatory taking analysis provided for by section [67-8003](#), Idaho Code, consistent with the requirements established thereby .

#### Hayden City Code

12-3-4 (F) Standards for Approval: The applicant has demonstrated that all existing and proposed infrastructures meets or can be constructed prior to the final plat or within the approval duration identified in 12-3-4(G) from the date of city council approval of the master development agreement which approved the preliminary plat to meet the following standards.

1. Infrastructure can be constructed to function in a manner that promotes the public health, safety, and welfare.

2. Infrastructure can be constructed and located in an orderly manner that accommodates ongoing maintenance needs when taking into consideration collocation of other infrastructure.
3. Infrastructure is or will be in compliance with applicable city, state, and federal policies and regulations as follows:
  - a) Provisions have been made for a water supply system that satisfies city, Idaho Department of Environmental Quality (IDEQ) and Northern Lakes Fire Protection District requirements.
  - b) Provisions have been made for a public sewage system in accordance with the city and Hayden Area Regional Sewer Board's (HARSB) adopted sewer master plans, as amended, that satisfied city, HARSB, and IDEQ requirements and that the existing or proposed systems can accommodate the proposed sewer flows.
  - c) Provisions have been made for snow storage that satisfies the City Public Works Department as the design relates to snow storage and removal practices. If snow storage is proposed to be co-located with stormwater, it shall only be in roadside swale areas and not in regional detention basins unless approved administratively by the City engineer who shall determine that the likelihood of flooding is minimal.
  - d) Provisions have been made for stormwater systems that satisfy the city and IDEQ requirements.
  - e) Provisions have been made for streets that are consistent with the adopted transportation plan, as amended, and the transportation element of the adopted comprehensive plan, as amended, and that satisfies the city, ITD, adjacent jurisdictions, and local highway district requirements. Where cul-de-sacs are proposed, they are required to be approved administratively by the City engineer who shall determine that they are limited to portions of developments in which street continuity is not foreseeable due to property configurations and /or that they are needed to address site-specific conditions. A cul-de-sac shall be limited to 400' in length measured from the edge of adjacent street right-of-way to the back of the cul-de-sac, unless an exception to this standard is allowed by the City Engineer.
  - f) Provisions have been made for parks and open space that are consistent with the adopted parks master plan, as amended, and that satisfies the city's requirement.
4. Provisions have been made for erosion controls and geo-hazards stabilization both during construction and as needed for permanent controls to the satisfaction of the city.

5. Provisions have been made for gas, power, telecommunications, mailboxes, and similar infrastructure.
6. Provisions have been made for driveway locations that take into consideration the width and location of the driveway in relation to the location of snow storage, utility boxes, crosswalks, adjacent roads, mailboxes and the like.
7. The area proposed for subdivision is zoned for the proposed use and the use conforms to other requirements found in this code.
8. The developer has made adequate plans to ensure that the community will bear no more than its fair share of costs to provide services by paying fees, furnishing land, or providing other mitigation measures for off-site impacts to streets, parks, and other public facilities within the community. It is the expectation that in most cases, off-site improvements will be dealt with through the agreements.

#### 12-3-4: PROCEDURES

A. Subdivision Plan Standards: Every subdivision plan shall consist of one or more maps, prepared by an engineer or surveyor licensed in the State of Idaho and drawn to a scale that is reasonable and legible with written data which considered together, they shall fully and clearly disclose the following information:

1. The name of the proposed subdivision;
2. The legal description of the land contained within the subdivision;
3. The names, mailing addresses, telephone numbers, fax numbers and e-mail addresses of the applicant and all persons, firms and corporations holding interests in said land;
4. Proof of ownership and consent from all property owners and lienholders granting authorization to subdivide the property and the name and contact information of the authorized agent;
5. A list, prepared by a title company licensed to do business in the State of Idaho, of the names and mailing addresses of all property owners whose property is within or adjacent to the area bounded by lines three hundred feet (300') from the external boundary of the entire proposal area. Such list shall be provided on self-adhesive labels in the number of copies necessary for the hearing(s) scheduled. Said list shall be accompanied by a date stamped tax map prepared by Kootenai County;
6. The name, a mailing address, telephone number, fax number, and e-mail address of the Idaho licensed engineer that prepared the plan;
7. The location of the boundary lines of the proposed subdivision in relation to section, quarter section and quarter-quarter section lines and any adjacent corporate boundaries of the City which are part of the legal description of the property;
8. The boundaries and dimensions of all blocks and lots within the proposed subdivision together with the numbers proposed to be assigned each block and lot. A lot utilized for open space, placement of utility infrastructure such as a lift station, and the like shall be titled a "tract";
9. A data table showing the number of lots, the smallest, largest and average lot area within the proposal site, the total acreage of the entire proposal area, and the density in lots per acre;
10. A statement of proposed provisions for irrigation/domestic water supplies and sewage disposal in the form of a will serve letter from the applicable purveyor, and the Idaho Department of Environmental Quality approved facility plan, if applicable;

11. A sketch map of the general vicinity in which the land proposed for subdivision lies prepared at a scale of not more than four hundred feet (400') to the inch. The vicinity map shall show all adjacent lots and shall show how the streets and alleys in the proposed subdivision connect with existing and proposed streets and alleys in neighboring subdivisions and unplatted property;

12. Any existing or proposed easements and right-of-way dedications, easements to be labeled with the name of the recipient and purpose of the easement;

13. All existing and proposed streets. Show plan, profile and cross sections along with street names (existing and proposed);

14. All adjacent streets. Show existing right-of-way width, and the location of centerline, swales, curbs and sidewalks, and trees;

15. Show location of existing structures such as septic tanks, drain fields, underground storage, wells, houses and outbuildings with notes to indicate if they will remain or be removed along with setbacks from proposed lot lines and streets. Additionally, show the location of any natural features such as wooded areas, streams, drainageways, flood hazard areas identified on the flood insurance rate map, rock outcroppings, or other sensitive, hazardous, or difficult to develop areas;

16. Location, dimensions and area of all tracts of land to be set aside for parks, open space, or other public use or for the use of property owners in the proposed subdivision. Include information on park amenities and uses demonstrating compliance with the City's park plan, annexation agreements, development agreements and the like;

17. Provide a graphic and narrative depicting and explaining development phases, or stages, if the project will be done over several years;

18. Provide preliminary construction plans (typically 50 - 70 percent design unless otherwise approved by the City Engineer) for the subdivision demonstrating constructability and functionality which shall include:

a. Proposed utility infrastructure plan indicating locations, sizes and approximate centerline grades;

b. General grading plan showing existing and proposed topography, identifying areas of cut and fill of over two feet (2') along with and existing and proposed all surface water flow patterns. Conceptual stormwater management plans for all proposed subdivision infrastructure shall be provided;

c. Pedestrian and bicycle circulation plans;

d. A general right-of-way landscape plan;

e. Proposed mailbox locations;

f. Traffic studies;

g. Snow storage and removal plan;

h. Geotechnical or similar study, if required by the City Engineer.

19. For projects which may result in potential negative impacts from the proposed development, additional studies to evaluate the impacts and identify potential mitigation measures may be required as part of the project review process. Such studies may include, but not be limited to, the following:

a. Additional transportation impact analysis shall be required for all development as identified in the currently adopted Traffic Impact Analysis policies.

(1) The requirement may be waived by the City Engineer after his/her review of the City's traffic model and a determination that the analysis is not likely to result in the need for mitigation.

(2) The applicant shall be responsible for all costs associated with a transportation impact analysis and potential mitigation as defined in the study.

b. Additional infrastructure plans and feasibility analyses may be required for submittal to the city for sewer collection and pretreatment infrastructure as required by the City's currently adopted Master Sewer Plan.

c. Additional infrastructure plans and feasibility analyses may be required for submittal to the City for stormwater collection infrastructure in accordance with the City standards and Idaho Department of Environmental Quality standards.

d. Additional geotechnical and/or environmental studies may be required to be completed by the applicant for submittal as part of the project review process, in circumstances where:

(1) Construction activities and/or processes will require blasting or construction activities and processes will result in excessive production of noise, smoke, fumes, odors, hazardous materials, emissions or discharges during construction;

(2) The proposed project is located in an area where sensitive or hazardous conditions are present (this may include, but is not limited to, certain soil conditions, shallow bedrock, seasonal high-water table, wetlands, surface water bodies, or slopes in excess of 15%), where said conditions create the need for special precautions during site construction; or

(3) The project contains a documented and unmitigated environmental hazard, including, but not limited to, underground storage tanks, illegal dump sites, contaminated soils, or other such "brown field" conditions as may be documented.

B. Agency And Public Notice: Once the City staff has reviewed the application and the staff has determined that the application is complete and that sufficient information regarding the proposal can be provided, notice will be provided to involved public agencies, as identified by the City. This notice shall allow fourteen (14) days for agency comment and the results of the agency comment shall accompany and be incorporated in summary in the staff report. At least fifteen (15) days prior to the public hearing notice of the public hearing, shall be published in the official newspaper of the City and shall be provided by mail to those property owners owning land within three hundred feet (300') of the external boundaries of the land being considered along with any additional properties that may be substantially impacted by the proposed subdivision, said determination of substantial impact is to be made by the Planning and Zoning Commission. When notice is required to two hundred (200) or more property owners, extraordinary notice may be given as provided by State law. Notice will also be provided, posted and maintained in accordance with the standards of section [11-12-4](#) of this Code. The applicant shall bear all costs of publication, mailing of the notices, and posting on the property. The assessors' maps and the title company search will be current within the sixty (60) days prior to issuing notice to the public agencies. If the information is more than sixty (60) days old at the time the notice is issued, the applicant shall provide current information.

C. Planning and Zoning Commission Public Hearing: At, or prior to, the public hearing, the City staff (Planning, Engineering, and other staff as required) shall provide a Staff Review for the Planning and Zoning Commission. This staff review shall address the request based on the standards of approval and City Code, adopted facility plans, including but not limited to transportation, sewer and parks, policies and standards, and provide staff recommended conditions of approval to ensure compliance with the City's requirements.

D. Planning And Zoning Commission Recommendation: After the Planning and Zoning Commission has reviewed the subdivision plan at the public hearing, the commission shall forward a written recommendation to the City Council. The commission shall recommend approval, approval with conditions, or disapproval of the subdivision as soon as practicable. The

City staff shall provide the written recommendation of the commission to the developer and shall advise the developer that the subdivision will be placed on the agenda of the City Council at the earliest practicable date, only upon the developer's written request.

E. City Council Decision: Upon receipt of a written request that the subdivision be placed on the Council agenda, the subdivision request will be placed on the next available Council agenda. The City Council, upon receipt of recommendations from the Planning and Zoning Commission, and after opportunity to review the file and minutes from the public hearing, shall act upon the request. The City Council may approve, approve with conditions, or disapprove the subdivision. City staff will notify the developer in writing of the decision of the City Council. Should the Planning and Zoning Commission recommend a substantive change to the preliminary subdivision plan involving a significant change, including, but not limited to, substantial changes in layout, density, or points of access, a public hearing may be required before the City Council, with proposed revisions as recommended by the commission subject to agency and public notice requirements for a public hearing, as detailed in subsection B of this section. Should the applicant wish to contest the recommendations of the Planning and Zoning Commission, the applicant may provide a written statement of their objections regarding the Planning Commission recommendations for inclusion in the City Council deliberations on the subdivision request. Such written statements must be received at least five (5) days prior to the scheduled City Council meeting.

F. Standards for Planning and Zoning Commission or City Council Approval: The applicant has demonstrated that all existing and proposed infrastructures meets or can be constructed prior to final plat or within the approval duration identified in [12-3-4\(G\)](#) from the date of City Council approval of the master development agreement which approves the preliminary plat to meet the following standards:

1. Infrastructure can be constructed to function in a manner that promotes the public health, safety, and welfare.

2. Infrastructure can be constructed and located in an orderly manner that accommodates ongoing maintenance needs when taking into consideration collocation of other infrastructure.

3. Infrastructure is or will be in compliance with applicable City, State, and Federal policies and regulations as follows:

- a. Provisions have been made for a water supply system that satisfies City, Idaho Department of Environmental Quality (IDEQ) and Northern Lakes Fire District requirements.

- b. Provisions have been made for a public sewage system in accordance with the City and Hayden Area Regional Sewer Boards (HARSB) adopted Sewer Master Plans, as amended, that satisfied City, HARSB, and IDEQ requirements and that the existing or proposed systems can accommodate the proposed sewer flows.

- c. Provisions have been made for snow storage that satisfies the City Public Works Department as the design relates to snow storage and removal practices. If snow storage is proposed to be co-located with stormwater, it shall only be in roadside swale areas and not in regional detention basins unless approved administratively by the City Engineer who shall determine that the likelihood of flooding is minimal.

- d. Provisions have been made for stormwater systems that satisfy the City and IDEQ requirements.

- e. Provisions have been made for streets that are consistent with the adopted transportation plan, as amended, and the transportation element of the adopted Comprehensive Plan, as amended and that satisfies the City, ITD, adjacent jurisdictions, and local highway district requirements. Where cul-de-sacs are proposed, they are required to be approved administratively

by the City Engineer who shall determine that they are limited to portions of developments in which street continuity is not foreseeable due to property configurations and/or that they are needed to address site specific conditions. A cul-de-sac shall be limited to four hundred feet (400') in length measured from the edge of adjacent street right-of-way to the back of the cul-de-sac, unless an exception to this standard is allowed by the City Engineer.

f. Provisions have been made for parks and open space that are consistent with the adopted Parks Master Plan, as amended, and that satisfies the City's requirement.

4. Provisions have been made for erosion controls and geohazards stabilization both during construction and as needed for permanent controls to the satisfaction of the City.

5. Provisions have been made for gas, power, telecommunications, mailboxes, and similar infrastructure.

6. Provisions have been made for driveway locations that take into consideration the width and location of the driveway in relation to the location of snow storage, utility boxes, crosswalks, adjacent roads, mailboxes and the like.

7. The area proposed for subdivision is zoned for the proposed use and the use conforms to other requirements found in this Code.

8. The developer has made adequate plans to ensure that the community will bear no more than its fair share of costs to provide services by paying fees, furnishing land, or providing other mitigation measures for off site impacts to streets, parks, and other public facilities within the community. It is the expectation that in most cases, off site improvements will be dealt with through the agreements.

G. Approval Duration: Failure to file the final plat application within two (2) years after the date of City Council approval of the master development agreement which approved the preliminary plat shall cause all approvals of said subdivision plan to be null and void, unless an extension of one year has been applied for by the developer and approved by the City Council, except as provided for in subsection I3 of this section. After the two (2) years have elapsed, the developer may apply for and receive additional extensions for good cause of time if actual work has been commenced and is continuing on the installation of the improvements up to a maximum of five (5) years, after which the preliminary plat approval shall be null and void and reapplication for a new preliminary plat application shall be required.

H. Changes, Alterations Or Deletions:

1. Upon issuance of agency and/or public hearing notices, and prior to approval of the preliminary subdivision plan by the City Council, any alterations of the plan must be reviewed by the Community and Economic Development Director or his/her designee to determine if the alterations are considered substantive. If the amendment is major or involves a substantial or significant change to the plan, said changes may be subject to agency and public notice requirements as detailed in subsection B of this section.

2. After approval of the subdivision plan and before approval of a final subdivision plat, the City Engineer may, in writing, approve minor changes of the plan. If an amendment is major or involves a substantial change in the conditions of approval, the same procedures for a public hearing for subdivision plan approval must be followed to address the requested amendment. The public hearing on the proposed amendment shall be limited to the proposed amendment, and the commission shall make a decision to recommend approval, approval with conditions, or denial. The recommendation will be brought forward for City Council decision as an addendum to the development agreement.

I. Phasing Of Subdivisions:

1. Subdivisions may be phased, to be developed in portions periodically according to a proposed schedule, so long as each phase contains all of the necessary improvements to function as a subdivision without the completion of any of the other phases. The developer shall indicate plans for phasing at the time of application. The plans shall show proposed phasing boundaries, proposed interim or temporary solutions to sanitary sewer systems and to the handling of traffic on local streets within the subdivision and shall be accompanied by a narrative description of assurance of completion of permanent system improvements.

2. A phasing plan shall coordinate required infrastructure systems, dedications, off site improvements, open space/parks, landscaping, private utilities, or other elements of a subdivision. The plan may indicate times of triggering mechanisms for improvements.

3. Approval duration for phased subdivision: The application for the first plat in a phased subdivision shall be made in accordance with section [12-3-3](#) of this chapter and the final plat application for the final phase of a phased subdivision shall be submitted no later than five (5) years after the date of City Council approval of the master development agreement which approved the entire subdivision in concept unless extensions of one year have been applied for by the developer and approved by the City Council or if some other time frame has been agreed to in the master development agreement.

## INFRASTRUCTURE COMPLIANCE WITH APPLICABLE CITY, STATE, AND FEDERAL POLICIES AND REGULATIONS

### POTABLE WATER AND FIRE-FLOW

Will serve letters are required by Hayden City Code §12-3-4(A) (10). The city does not participate in the QLPE (Qualified Licensed Professional Engineer) review of the construction plans for subdivisions as it relates to water and/or sewer. Therefore, the City relies on the Idaho Department of Environmental Quality (IDEQ) for their interpretation of the adequacy of the Will Serve letter to meet the requirements of the Idaho Code section 67-6526 to have the sanitary restriction lifted and to determine if the water and sewer infrastructure construction will meet Idaho Code Requirements. If IDEQ does not lift the sanitary restriction, building permits cannot be issued by the City.

The Developer shall be required to provide all dedications and easements, and construct appurtenances as may be required by the water district at the time of development.

The Developer shall be required to provide detail on the location, size and design of all water system improvements, including water lines, stubs, meters, and fire department connections and hydrants as part of the construction drawing for required subdivision improvements.

### SEWER - CITY AND HARSB

The sewer system consists of both a collection system consisting of gravity lines, force mains and lift stations (owned and operated by the City of Hayden) and wastewater treatment facility and regional force mains (owned and operated by the Hayden Area Regional Sewer Board – HARSB). Hayden City Code §12-3-4(F) (3) (b), as a standard of approval, requires that “provisions have been made for a public sewage system in accordance with the City and Hayden Area Regional Sewer Board (HARSB) adopted sewer master plans, as amended, that satisfied City, HARSB, and IDEQ requirements and that the existing or proposed systems can accommodate the proposed

sewer flows”. Additionally, to meet this requirement a will serve letter from the utility provider confirming that the provider has the current availability, capacity, authority and willingness to service the proposal with the requested service must be provided as part of the application submittal.

At the time of future development, the developer shall be required to construct all sewer infrastructures in conformance with the City of Hayden 2020 Collection System Master Plan Update, State law, and all City sewer policies, standards and technical memos. All sewer manholes shall be placed on the centerline or within public roadways unless approved by the City. Public sewer shall be located within roadways within public rights-of-way or private tracts as appropriate. Revisions to the overall layout may be required where sewer is shown to be running in locations which are not within these locations.

Revisions to the conceptual plans may be required by the City Engineer as part of the construction plan approval for the subdivision. The Developer shall be required to reflect all necessary sewer easements on the face of the final plat of the subdivision

### **Ability to Provide Sewer Service**

The City issues Will Serve letters that are non-binding generalized statements of their agency’s ability and desire to provide sewer service under current circumstances. A Will Serve letter is not a guarantee of service because the actual physical connection to utilities takes place under a separate authorization, generally with a building permit, which can be issued in the near or far future. As such, time may have passed and circumstances change; or perhaps something arises in detailed plan review that affects the ability to provide service, which is why the City cannot guarantee at this time that future capacity will be available and is only able to determine this at the time of authorization to physically connect to the utilities.

### **STORMWATER**

City Code Title 8 prohibits the acceleration, concentration, and/or conveyance of runoff, stormwater or other surface waters beyond the project boundaries. The stormwater management plan for the proposed development shall be designed in conformance with the above referenced City Code, with adopted road typical sections and their related design standards, and in conformance with the annexation agreement.

Stormwater easements shall be reflected on the face of the plat. No fences shall be placed within joint stormwater easement areas. Routine maintenance of joint stormwater areas on private property shall be the responsibility of the individual lot owner. Structural or functional maintenance of joint stormwater areas shall be the responsibility of a Homeowner’s Association.

### **STREETS, PEDESTRIAN PATHS, AND RIGHT-OF-WAYS**

#### **Transportation Impact Study:**

Hayden City Code §12-3-4(A) (18) identifies the possible need for a traffic study as part of the application submittals for a subdivision.

**Addressing Requirements:**

The Developer shall confirm street names comply with 9-1-1 emergency addressing requirements as detailed in City Code §9-5 and are deemed acceptable by the City, with said street name to be reflected on the preliminary and final subdivision plats.

**Street Requirements:**

Plan and Profile scales shall be not more than 1" = 50' Horizontal and 1" = 5' Vertical on an 11" x 17" drawing (or sheet of paper).

All required street improvements shall be in accordance with current City Standard Drawings, including pedestrian ramps, sidewalks, stormwater facilities, etc.

**Street Lighting:**

The Developer shall be required to provide street lighting construction plans along all internal streets and at intersections with external streets, as part of the construction drawings, meeting the design standards identified in Hayden City Code 11-4-5, to be installed as required subdivision improvements. The determination of adequate light coverage and the requirement of an additional light at both internal and external intersections shall be made by the City Engineer at the time of construction plan review.

**Signage:**

Break-away type street signs, including stop signs, speed limit signs, and other signs as may be required, shall conform with MUTCD standards, and shall be installed by the developer, with signs identified, and locations shown on construction plans to be approved by the City Engineer.

**Landscaping:**

Detailed landscaping plans, conforming to the requirements of City Code, with proposed landscaping along street frontages and proposed swales, shall be submitted for the entire development with construction plans for required subdivision improvements, for review and approval by the City.

Specifically, the developer shall be required to provide a minimum of a "Type IV" landscape buffer along all street frontages. Regarding swales and required landscaping along street frontages adjacent to the internal streets, the swale shall be constructed and seeded with an approved seed mix prior to final plat approval and the Type IV landscaping shall be a requirement of the building permit.

The finish construction of the swale and street frontage landscaping shall include installation of swale turf grass and drainage infrastructure, approaches, street trees, and irrigation systems, and shall be the responsibility of the property owner (or their representative) and shall be installed as a required condition of approval for a residential building permit. The work within the right-of-way shall only be authorized through an approved right-of-way encroachment permit and shall be guaranteed by the permittee in accordance with Hayden City Code §7-2-19.

## EROSION CONTROLS AND GEO-HAZARD STABILIZATION:

The site topography is relatively flat; however, erosion control measures shall be identified on the construction plans.

## GAS, POWER, TELECOMMUNICATIONS, MAILBOXES:

Dry utilities, including electric, gas, cable, and communication utilities shall be installed underground within the development, in accordance with City Code Title 12.

The Developer shall identify mailbox locations that have been approved by the Hayden Postmaster for project site, and provide an approval by the postmaster at the time of construction plan submittal. The City prefers the mailbox location to be on an internal street. Prior to construction plan approval, the Developer shall work with the US Post Office to address any required turnouts, if determined necessary by the City Engineer, and shall be included in the construction plans. If easements are needed, these shall be required to be shown on the final plat.

## DRIVEWAY LOCATIONS:

The final location of all driveway locations shall be subject to the review and approval of the City and in accordance to the standard detail of ST-013. Particular attention will be paid to those lots at intersections to avoid conflict with required traffic flow; and to those driveway locations, which may be in conflict with existing and proposed infrastructures. All lots shall be accessed from an internal street.

## COMPREHENSIVE PLAN GOALS, POLICIES, and ACTIONS:

The Vision of the City of Hayden is as follows:

*Hayden is a well-managed Idaho town that prioritizes responsible growth and mature infrastructure planning practices to provide a variety of housing options, to encourage small business development, and to protect its natural resources.*

*GOALS: Broad, community-supported statements that express long-term aspirations based on public input and regional coordination. A goal is a direction setter. It is an ideal future state or condition related to the public health, safety, or general welfare toward which planning, and implementation actions are directed. A goal is a general expression of community values and is somewhat abstract in nature. Consequently, a goal is generally not quantifiable, time-dependent, or suggestive of specific actions for its achievement.*

*POLICIES: Clear guidelines that reflect community values and direct decision-making on land use, infrastructure, and public investment. A policy indicates a clear commitment of the Hayden City Council. A policy is an extension of the Plan's goals, reflecting topical nuance as well as an assessment of conditions and how the City will respond.*

Table 2-1: Component Abbreviations

Abbreviation	Chapter Listing
LU	Land Use
NR	Natural Resources
HA	Hazardous Areas
PR	Parks and Recreation
T	Transportation
PF	Public Facilities
U	Utilities & Infrastructure
H	Housing
CD	Community Design
I	Implementation
ED	Economic Development
CBD	Central Business District

No.	Goal	Policy Reference	Impl. Reference
1	The City of Hayden will promote and actively participate in intergovernmental coordination efforts at the regional and at the local level.	1	LU; H; NR; HA; ED; PR; U; PF
2	While protecting and strengthening existing neighborhoods, maintain an attractive and sustainable mixture of land use zones and housing options that promote responsible development decisions. All development will consider and implement adequate parks and open leisure space for each neighborhood. Parks and leisure space will provide a variety of recreational opportunities and complement their associated neighborhood.	2, 3, 4, 5, 6, 9, 17	LU; H; PR; CD
3	Developed land will be serviced by adequate, planned, environmentally-sound public facilities and utilities to maintain infrastructure integrity and provide reliable service. Ensure infrastructure development costs are shared equitably. Hayden will prioritize developing land inside the City's borders before seeking adjacent land annexation.	6, 7, 9	PF; U; CD; LU; HA; NR
4	Solidify a Central Business District that encourages and supports locally owned businesses and provides Hayden citizens employment opportunities. Augment the Central Business District by maintaining commercial uses along Hayden's primary transportation corridors.	8, 9, 10, 11	LU; CD; ED; T
5	Promote neighborhood pedestrian and non-motorized interconnectivity between neighborhoods and throughout the Central Business District. Encourage Neighborhood Nodes that reduce traffic and increase community engagement.	12, 13, 14	T; LU; CD; ED
6	Protect, preserve and be stewards of our environment's natural areas and resources which enhance the quality of life in the City.	15, 16	NR; HA; PR
7	Ensure that Ordinances and Policies do not violate private property rights, adversely impact property values or create unnecessary limitations on land use.	2, 17	LU; ED

No.	Policy	Goal Reference	Impl. Reference
1	Hayden will coordinate with adjacent County and City leadership, regional quasi-governmental and other public agencies as required to provide compatible services, protect natural resources including the water and park systems, and promote regional transportation solutions.	1	LU; NR; HA; ED; PF; U; T
2	Development will be compatible with the land use chapter of the Comprehensive Plan and fiscally responsible in supplying adequate transportation, utilities, and parks to newly developed areas; minimizing increased taxes to residents, where possible.	2, 7	LU; ED; T; PF; PR; NR
3	Development will be managed to provide transition between business and residential zones.	2	CD; ED; LU
4	A variety of cohesive housing options will be encouraged when considering “infill” projects.	2	H; LU; ED; CD
5	Parks, leisure or natural space will be incorporated into all future housing development projects. Working with the private sector, usable open space projects will be funded and prioritized ahead of housing, where existing adjacent development has not provided neighborhood recreational development.	2	PR; NR; H; LU
6	Hayden will evaluate development project infrastructure impact, including public facilities and utility services, on existing City resources. Infrastructure will be planned and developed to accommodate anticipated City growth.	2,3	PF; U; ED; CD
7	Adequate infrastructure resources must support annexation decisions.	3	LU; PF; U; ED; CD
8	Concentrate primary business development in the Central Business District, in established industrial park developments, and along primary transportation corridors.	2, 4	LU; ED; CD; T
9	Higher density housing options will be encouraged along primary transportation corridors, where development doesn’t interfere with established neighborhoods.	2, 3	H; LU; T; CD

No.	Policy	Goal Reference	Impl. Reference
10	Prioritize business development in the Central Business District that creates jobs and generates property tax revenue.	4	ED; LU; CD
11	Encourage small-scale retail and service businesses that support the City and attract a live, work, play lifestyle for the citizens.	4	ED; LU; CD
12	Establish non-vehicular pathways that promote access to neighborhood parks and node-location retail businesses.	2, 5	T; LU; PR; ED; CD
13	Provide ample parking that encourages foot travel among Central Business District located businesses.	5	T; ED; CD
14	Create neighborhood-appropriate retail and service nodes that reduce traffic and promote pedestrian or non-vehicular travel.	5	CD; ED; T; LU
15	Land use decisions will identify setbacks and infrastructure that protect identified natural resources and environmentally sensitive areas. Land use decisions will also consider the preservation of historical structures.	6	LU; U; PF; T; NR; HA; PR
16	An environmental impact analysis will be completed ahead of implementing projects that compromise previously undeveloped acreage, natural resources and environmentally sensitive areas.	6	NR; HA
17	Protect lives and property from environmental and man-made risks and hazards.	3, 7	LU; NR; HA

# Applicant's Materials

Project Narrative  
Monaghan Estates  
AIN:172581 and 172582  
Hayden, ID

Prepared by:  
Olson Engineering  
1649 Nicholson Center St. Suite #102  
Post Falls, ID 83854

March 12, 2026

## Legal Descriptions

PTN TAX#14100 EX RW

AVONDALE, PTN TAX#14100 EX RW

## Project Location

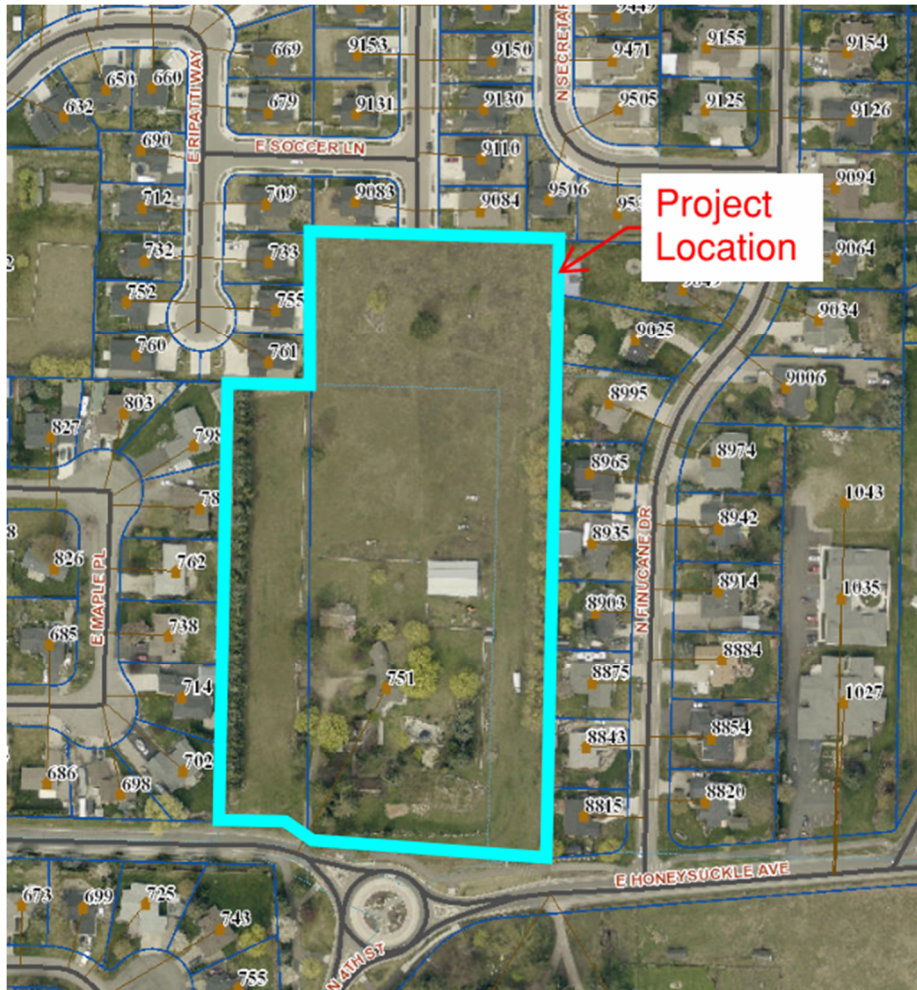

Vicinity Map

## Project Location

This project is located within the City of Hayden city limits, north of E Honeysuckle Ave and west of N Finucane Dr. Access roads for the project will tie into the south end of N Secretariate Ln as well as providing a right-in/right-out approach off E Honeysuckle Ave.

### Site Conditions

The property to be subdivided consists of two parcels consisting of a total of 8.67 acres. This property is relatively flat and contains one single family residence and several outbuildings, all of which will be demolished as part of the project. The site has generally been cleared of native vegetation by previous property owners and contains mostly grass with a few scattered trees around a single-family residence.

No topographical anomalies or irregular soil conditions have been identified and the property is not within any known wetlands. The site is over the Rathdrum Prairie Aquifer which generally consists of very well drained gravel soils which are suitable for road and building construction.

### Project Proposal

This project proposes to subdivide the listed properties into 20 new single family residential parcels. The subject parcels are currently zoned Single Family Residential.

All existing structures are intended to be removed from the site as part of this project.

### Subdivision

The developer wishes to subdivide the land to allow for 20 lots of single-family housing options in this location. The proposed lots will range in size from 8,316 sq ft to 17,334 sq ft. The proposed project density is significantly lower than that allowed by the current zoning and the larger proposed lot sizes are equal to or larger than the majority of those in the surrounding neighborhoods.

The project also proposes to include one HOA owned tract that will contain a sport court and picnic pavilion for HOA use.

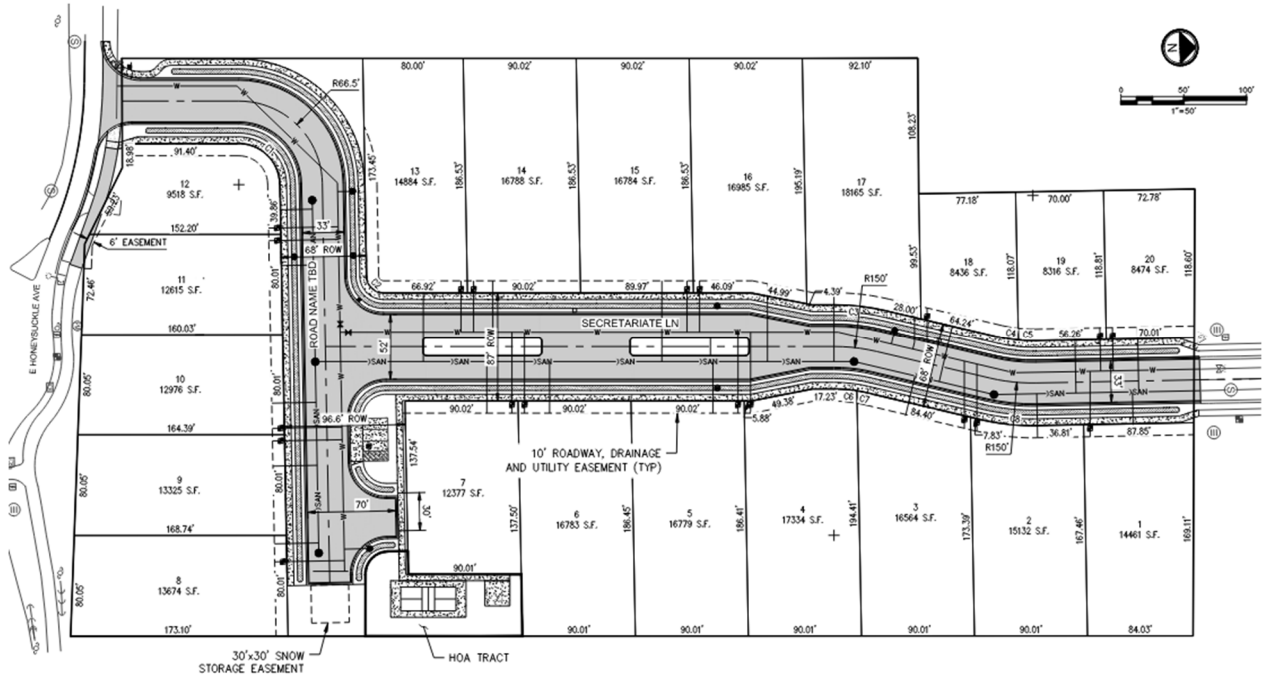

### Site Plan

#### Existing Zoning.

The property is currently zoned as Single Family Residential.

#### Surrounding Zoning

All surrounding properties are zoned Single Family Residential with Planned Unit Developments to the south and southwest.

#### Comprehensive Plan

This property is part of the City of Hayden, and the 2040 Comprehensive Plan offers guidance as to how the property will be best utilized upon redevelopment. Goals and policies can be found in Chapter 2-Policy Framework section of the comprehensive plan. The following goals and policies that are directly related to this proposal are as follows:

*“The City of Hayden should encourage the development of land within the corporate limits of Hayden prior to annexation of adjacent areas.”*

This parcel is currently within Hayden city limits so the development of this land should be encouraged over lands that require annexation.

*“Improve pedestrian, bicycle and vehicular safety along city streets.”*

This project connects the dead-end of N Secretariate Ln to Honeysuckle Ave which increases general vehicular and pedestrian connectivity throughout the city.

*“Coordinate the timely development of efficient, effective and environmentally sound sewer, water and other utility infrastructure servicing the community, assuring costs of development are shared equitably and accommodate for ongoing growth of Hayden.”*

The proposed water and sewer service to the development will connect to existing water and sewer stubs at the south end of N Secretariate Ln. Sewer service will be provided by the City of Hayden while water service will be provided by Avondale Irrigation District. The project proposes to eliminate a dead end line within Avondale Irrigation District’s system and add additional waterline looping which will increase water quality and circulation in the vicinity of the project.

This is the most effective and efficient option for sewer and water for this subdivision.

### Streets

This development will include additional frontage improvements along E Honeysuckle Ave to extend existing curb/gutter and mixed use path to the western edge of the subject properties. Streets internal to the project will be constructed per City standards and will be tied into the south end of N Secretariate Ln which is already stubbed out to the north property line. The streets will also tie into E Honeysuckle Ave. The intersection at Honeysuckle Ave will be designed to only allow right-in/right-out traffic movements to minimize impacts to existing traffic patterns on Honeysuckle Rd near the existing roundabout. The north/south portion of road extended as part of this project is proposed to be called N Secretariate Ln and the new east/west portion of road will be named prior to final platting.

## Utilities

Sewer will be provided by the City of Hayden and will tie into the existing gravity sewer system at the south end of N Secretariate Ln.

The subject parcel is located within the Avondale Irrigation District service area and already has an 8" water main stubbed out to the north property line within Secretariate Ln. The water main will be installed from this point through the project and tie into an existing 8" water main within the Honeysuckle right of way on the south side of the project.

Gas and electric will be provided by Avista.

Multiple data providers are available in the immediate vicinity.

## Summary

The owner of the property is requesting to subdivide an existing parcel located in the City of Hayden with Single Family Residential zoning. The Monaghan Estates Subdivision will provide attractive housing that will promote the neighborhood while increasing connectivity within the City.

The developer will be required to dedicate the necessary public rights-of-way, make required upgrades to all required public infrastructure (right of way, sewer and potable water) and pay permit and impact fees. In addition to adding to the City's tax base, these developer contributions will ensure that the development does not burden the residents of Hayden.

May 1, 2026

Community Development, Planning Division  
451 Government Way  
Coeur d' Alene, ID 83814**Re: Trip Generation and Distribution Letter for Monahan Estates Subdivision  
located in the City of Hayden.**

To whom it may concern.

Olson Engineering has provided a trip generation and distribution letter to demonstrate the possible impact of the proposed Subdivision. This letter is prepared to follow the standards required by the city and the Institute of Transportation Engineers (ITE) regarding vehicle trip generation.

**PROJECT DESCRIPTION**

The project site is a 8.67-acre vacant property. The proposed site will be accessed via Honeysuckle Ave and Secretariat Lane. The project will include 20 single family lots. The site is located north of Honeysuckle Ave in a portion of Section 24, Township 51N, Range 4W. The site is currently zoned as Single Family Residential.

**Existing Roadways**

The proposed project trips are anticipated to use the following roadways:

- E Honeysuckle Ave is an east/west, two-way, 2-lane access road. Local cross streets in the vicinity include Government Way, Finucan, and the roundabout at Honeysuckle/4<sup>th</sup> street. (90% distribution assigned)
- Where the project connects to the internal network of local streets coming out of The Fields subdivision, the most logical movement is to Maple Street via Soccer Lane and Ripatti Way. (10% distribution assigned)



**Conclusions:**

In summary based on ITE rates for LUC # 210:

Weekday ADT = 230 trips

AM Peak = 21 trips

PM Peak = 23 trips

Based upon the number of anticipated trips, and the distribution of those trips, we believe that the proposed project will have a minimal impact on the transportation system.

Should you have any questions related to this document please let me know.

Sincerely,

A handwritten signature in blue ink, appearing to read 'S. Soltys', with a stylized flourish extending to the right.

Steven P. Soltys, PE

# MONAGHAN ESTATES SUBDIVISION PRELIMINARY SUBDIVISION PLAN

LOCATED IN A PORTION OF SEC. 24, T.51N., R.4W., B.M.,  
CITY OF HAYDEN, KOOTENAI COUNTY, IDAHO  
KOOTENAI COUNTY PARCEL #: H-0000-024-1600 AND H-0450-241-03AB

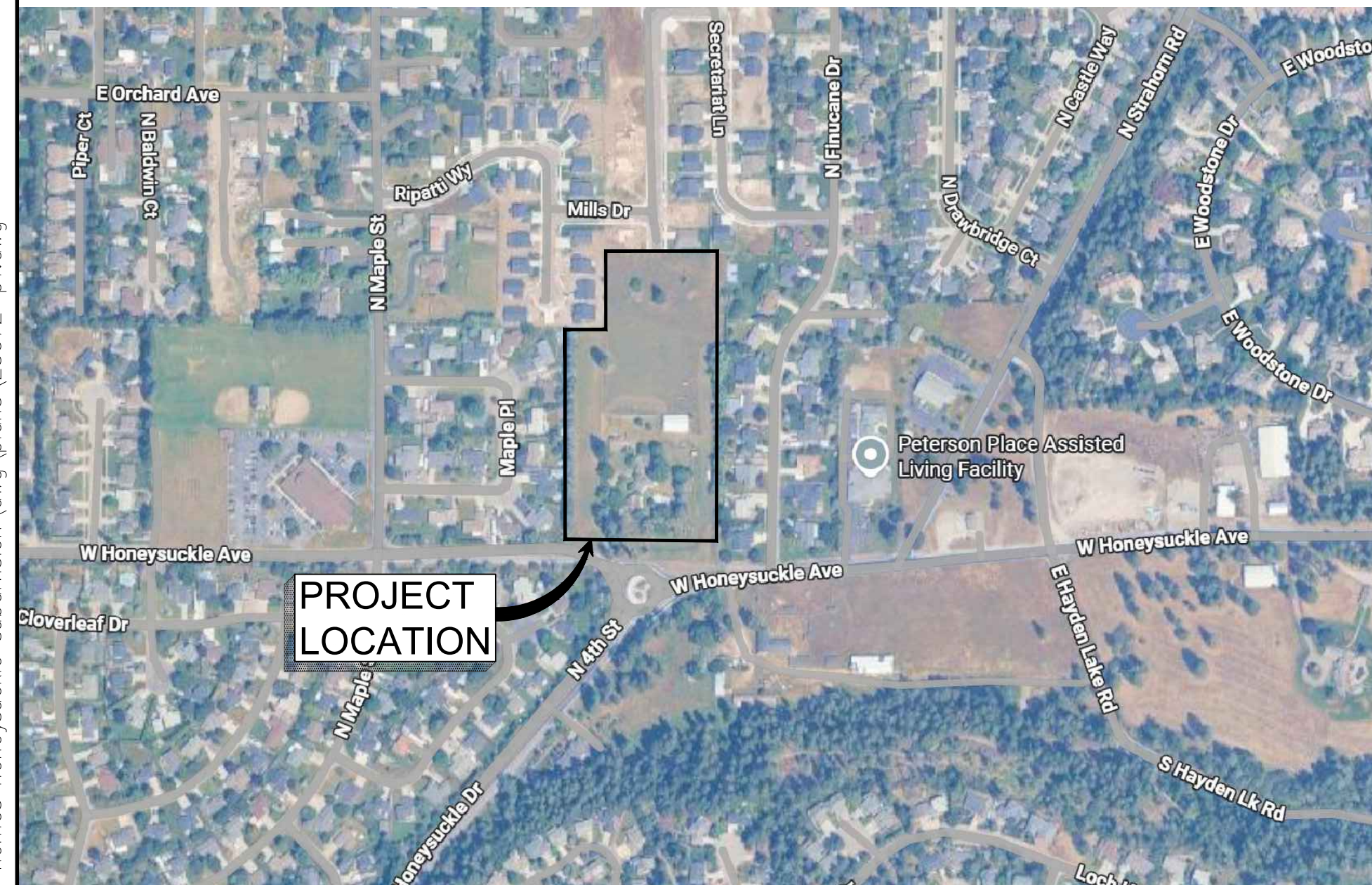

VICINITY MAP

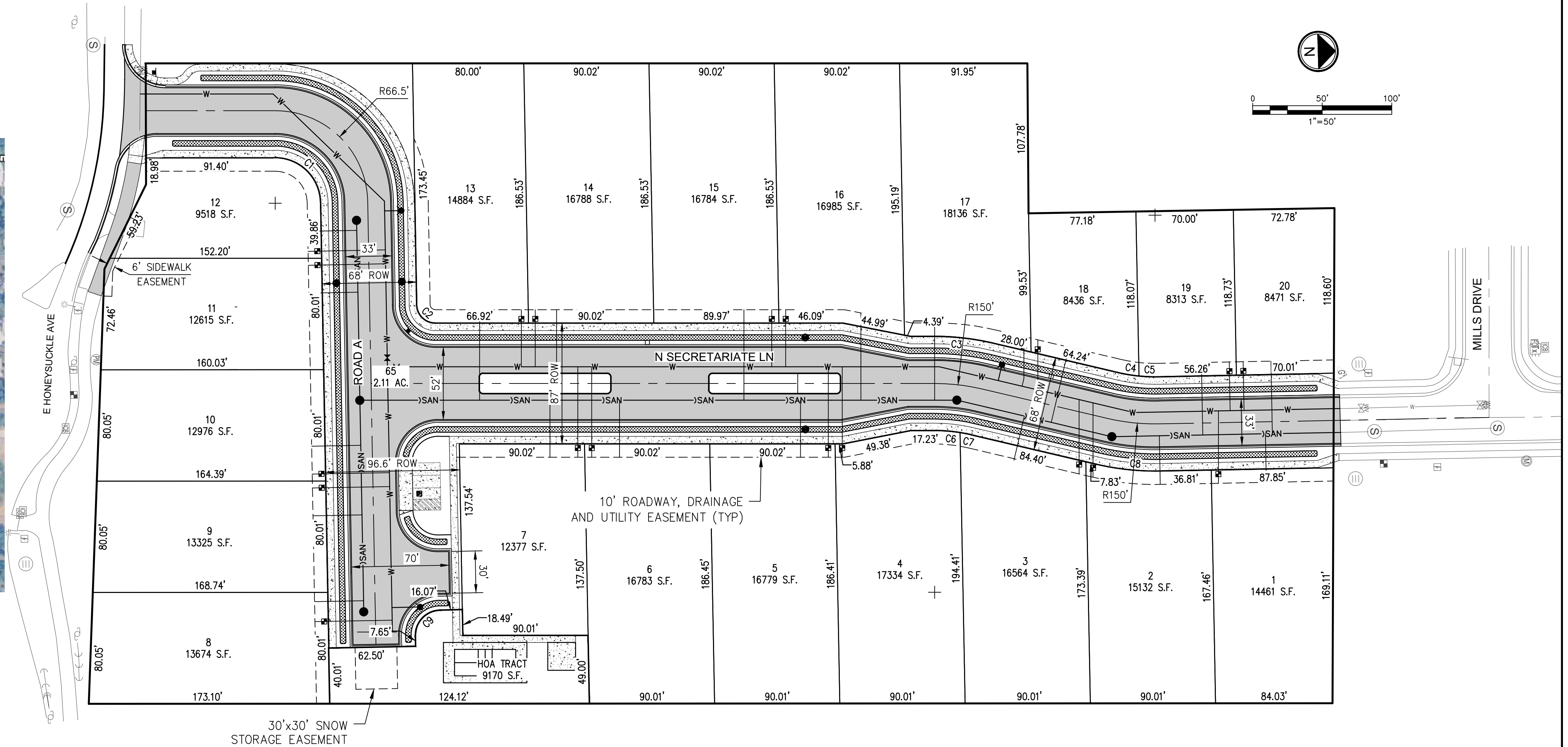

Parcel Curve Table				
SEGMENT	RADIUS	LENGTH	CHORD LENGTH	CHORD BEARING
C1	32.50'	52.25'	46.80'	N45°00'00"E
C2	13.33'	20.69'	18.68'	N45°58'47"E
C3	189.29'	42.47'	42.39'	N8°07'31"E
C4	116.00'	15.28'	15.27'	N10°57'58"E
C5	116.00'	13.77'	13.76'	N3°47'33"E
C6	116.35'	18.38'	18.36'	N6°03'03"E
C7	116.00'	8.40'	8.40'	N12°39'52"E
C8	184.72'	46.07'	45.95'	S7°33'56"W
C9	18.00'	28.31'	25.48'	N44°29'47"W

LOTS SUMMARY TABLE	
NUMBER OF LOTS	20
MIN. LOT SIZE	8,316 SF
MAX. LOT SIZE	18,165 SF
AVG. LOT SIZE	14,018 SF
TOTAL ACREAGE OF PARCEL	8.67 AC
LOTS/ACRE	2.31
HOA LOT	9,170 SF
RIGHT OF WAY	2.11 AC

	BUILDING SETBACKS (R1 ZONING)	
	PRINCIPAL STRUCTURE	ACCESSORY STRUCTURE
FRONT SETBACK	25'	35'
SIDE SETBACK	10'	5'
REAR SETBACK	25'	5'
FLANKING SIDE SETBACK	15'	15'

**Olson Engineering**  
1649 N. Nicholson  
Center St. Suite #102  
Post Falls, ID 83854  
208-651-4152  
eo@oeecivil.com

PRELIMINARY

PRJ: MONAGHAN ESTATES

loc: 751 E HONEYSUCKLE AVE  
HAYDEN, ID

sht: SUBDIVISION PLAN

#	DATE	REVISION

P-1

c:\users\calvin\olson\_engineering\olson\_engineering - projects\2025\25072 - aspen homes honeysuckle subdivision.dwg\plans\25072-p1.dwg

# MONAGHAN ESTATES SUBDIVISION CIVIL ENGINEERING PLANS

LOCATED IN A PORTION OF SEC. 24, T.51N., R.4W., B.M.,  
CITY OF HAYDEN, KOOTENAI COUNTY, IDAHO  
KOOTENAI COUNTY PARCEL #: H-0000-024-1600 AND H-0450-241-03AB

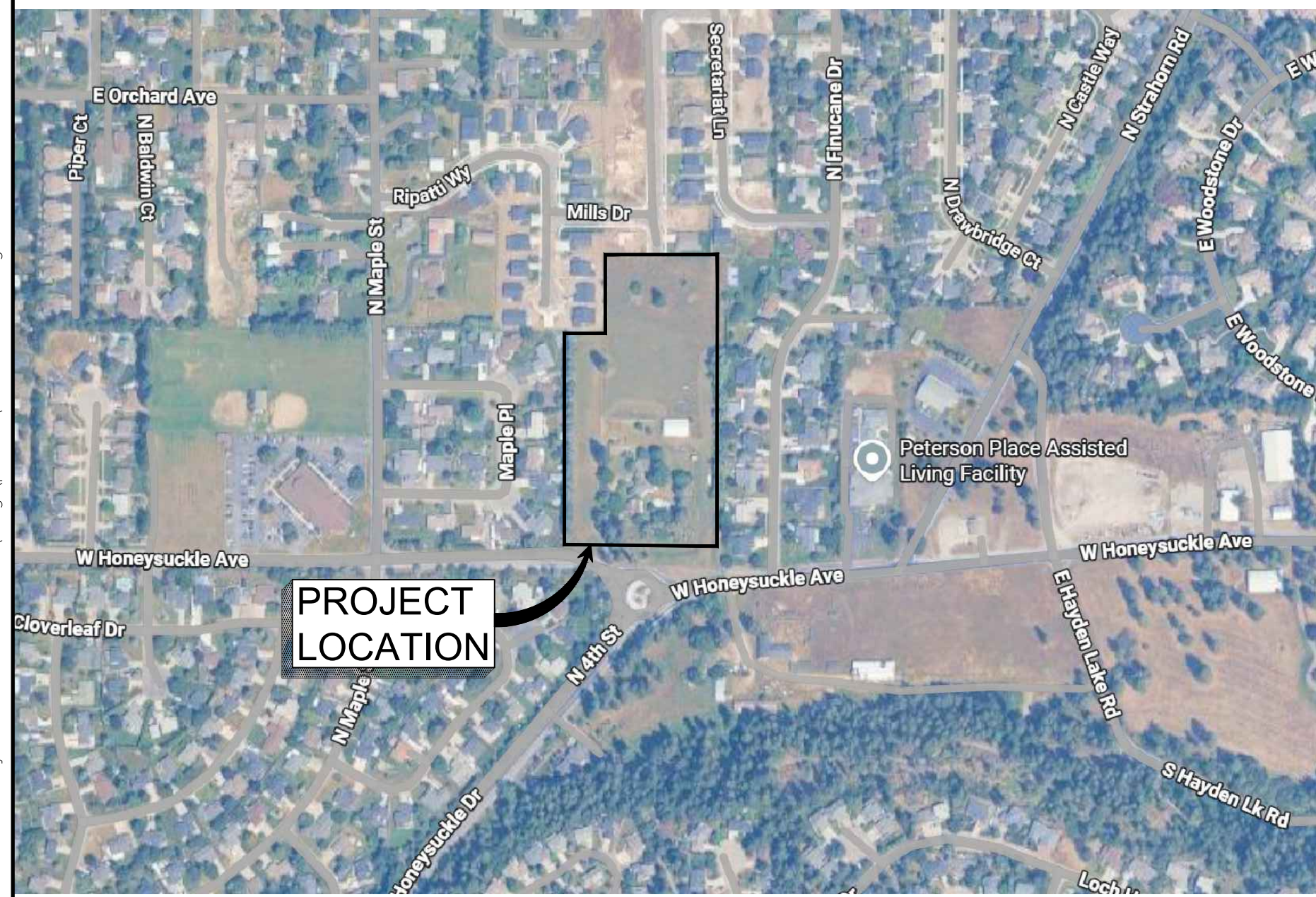

VICINITY MAP

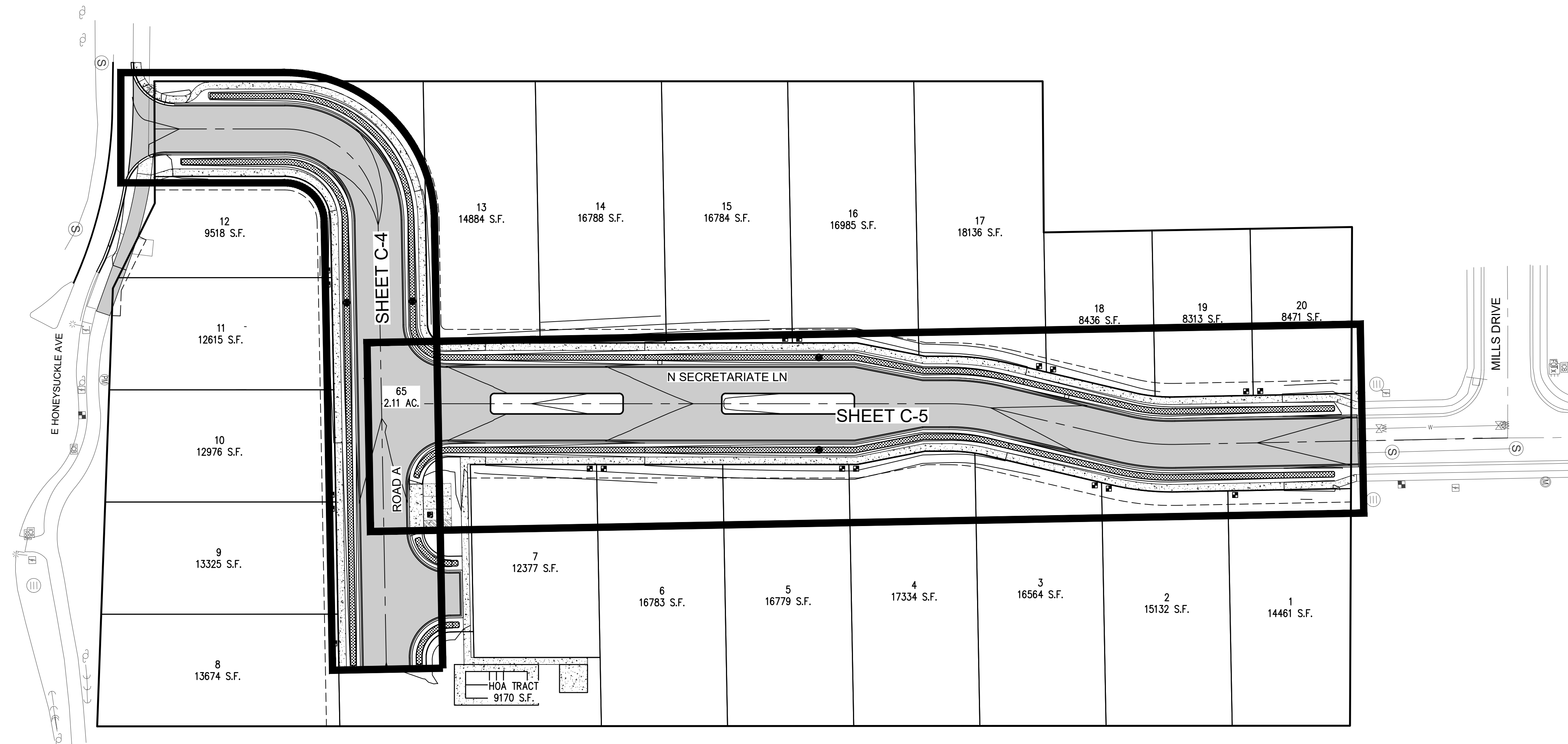

SITE MAP

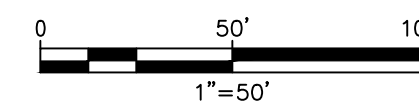
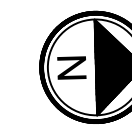

## MONUMENT SEARCH NOTE IC 55-1613

AVAILABLE RECORDS AND FIELD RESEARCH HAS BEEN CONDUCTED TO LOCATE EXISTING PROPERTY CORNERS ASSOCIATED WITH THE SUBJECT PROJECT. ALL EXISTING MONUMENTS ARE IDENTIFIED WITHIN THE PLANS, AND THEIR LOCATIONS SHALL BE VERIFIED PRIOR TO AND AT THE COMPLETION OF CONSTRUCTION PER IDAHO CODE 55-1613. EXISTING MONUMENTS SHALL BE PRESERVED AND PROTECTED THROUGHOUT THE COURSE OF CONSTRUCTION.

## VERTICAL DATUM

VERTICAL DATUM IS NGVD-29.

## CONSTRUCTION GENERAL PERMIT

THIS PROJECT IS LOCATED ON THE SPOKANE VALLEY RATHDRUM PRAIRIE AQUIFER WITH DEEP, EXTREMELY WELL-DRAINED GRANULAR SOILS. THERE ARE NO SURFACE WATER DISCHARGE POINT LOCATIONS ON SITE AND THEREFORE THE PROJECT IS EXEMPT FROM THE REQUIREMENTS OF THE EPA CONSTRUCTION GENERAL PERMIT.

## LEGEND OF EXISTING FEATURES

⊙	FOUND 5/8" REBAR WITH YELLOW PLASTIC, P.L.S. 15434	⊙	GAS STUB
◇	FOUND MAG NAIL AND SHINER, P.L.S. 15434	⊠	IRRIGATION CONTROL BOX
⊠	POWER TRANSFORMER	☼	STREET LIGHT
⊠	POWER STUB	⊙	STREET SIGN
⊠	WATER METER	⊠	CATCH BASIN
⊠	WATER STUB	■	CONCRETE
⊠	POWER VAULT	■	ASPHALT PAVEMENT
⊠	DRYWELL	—○—	CULVERT
⊠	SSMH	— —	FENCE
⊠	WATER VALVE		
⊠	FIRE HYDRANT		

## SHEET INDEX

C-1	COVER SHEET
C-2	GENERAL NOTES
C-3	TYPICAL SECTIONS
C-4	EXISTING CONDITIONS
C-5	ROAD A PLAN AND PROFILE STA: 10+00 TO 15+50
C-6	N SECTARIATE LN PLAN AND PROFILE STA: 10+00 TO 17+24

<p>811 Know what's below. Call before you dig.</p>	<p><b>PRELIMINARY</b></p>	
		<p>Olson Engineering 1649 N. Nicholson Center St. Suite #102 Post Falls, ID 83854 208-651-4152 eo@oecivil.com</p>
<p>prj: <b>MONAGHAN ESTATES</b></p>		
<p>loc: <b>751 E HONEYSUCKLE AVE HAYDEN, ID</b></p>		
<p>sht: <b>COVER SHEET</b></p>		
#	DATE	REVISION

C-1

c:\users\calvin\olson\_engineering\olson\_engineering - projects\2025\25072 - aspen homes honeysuckle subdivision.dwg\plans\25072-cl.dwg

**GENERAL NOTES:**

- ALL WORK SHALL CONFORM TO IDAHO STANDARDS FOR PUBLIC WORKS CONSTRUCTION (ISPMC), CURRENT EDITION AND CITY OF HAYDEN STANDARDS & POLICIES.
- EXISTING UTILITIES ARE SHOWN BASED ON GROUND SURVEY AND AVAILABLE RECORDS AND ARE NOT GUARANTEED TO BE COMPLETE AND ACCURATE. EXISTING UTILITIES SHALL BE LOCATED BY CONTACTING "CALL BEFORE YOU DIG" AT 811, AT LEAST 48 HOURS PRIOR TO EXCAVATION.
- WORK SHALL NOT BEGIN UNTIL ALL REQUIRED PLAN APPROVALS AND PERMITS HAVE BEEN OBTAINED. THE CONTRACTOR SHALL KEEP A COPY OF THE APPROVAL LETTERS AND/OR PERMITS ON SITE AT ALL TIMES DURING CONSTRUCTION.
- THE CONTRACTOR SHALL NOTIFY THE ENGINEER AT LEAST 48 HOURS PRIOR TO CONSTRUCTION TO COORDINATE CONSTRUCTION OBSERVATION AND INSPECTIONS.
- THE CONTRACTOR SHALL HAVE AN APPROVED SET OF CONSTRUCTION PLANS ON SITE AT ALL TIMES DURING CONSTRUCTION. NO REVISIONS SHALL BE MADE TO THE PLANS WITHOUT THE APPROVAL OF THE ENGINEER. APPROVED REVISIONS AND MINOR PLAN DEVIATIONS SHALL BE DOCUMENTED BY THE CONTRACTOR AND SUBMITTED TO THE ENGINEER AT THE COMPLETION OF THE PROJECT FOR THE PURPOSES OF PREPARING "AS-BUILT" DRAWINGS.F
- CONTRACTOR SHALL HAVE A COPY OF THE IDAHO DEQ OR QLPE PLANS AND SPECIFICATIONS APPROVAL LETTER ONSITE AT ALL TIMES DURING CONSTRUCTION OF POTABLE WATER AND SANITARY SEWER IMPROVEMENTS
- EXISTING PROPERTY CORNERS OR SURVEY MONUMENTS SHALL BE PROTECTED DURING THE COURSE OF CONSTRUCTION. ANY DAMAGED OR OBLITERATED CORNERS OR MONUMENTS SHALL BE RE-ESTABLISHED AT THE CONTRACTORS EXPENSE BY A PROFESSIONAL LAND SURVEYOR, LICENSED IN THE STATE OF IDAHO, PRIOR TO FINAL ACCEPTANCE.
- COMPACTION TESTING SHALL BE PERFORMED BY A QUALIFIED SOILS ENGINEER AND SUBMITTED TO THE ENGINEER. SEE PAVING GENERAL NOTES, TRENCH DETAIL, ETC. FOR REQUIRED COMPACTION LEVELS. COMPACTION TESTING SHALL BE PERFORMED AT THE FOLLOWING INTERVALS:
  - UTILITY TRENCH BACKFILL – 1 TEST PER EVERY 100 FEET OF TRENCH LOCATED IN THE PIPE ZONE, MID-DEPTH, SURFACE, AND AROUND MANHOLES.
  - ROADWAY EMBANKMENT – 1 TEST PER 100 LINEAL FEET.
  - CURB AND GUTTER SUBGRADE – 1 TEST PER 100 LINEAL FEET.
  - ROAD SUBGRADE, ROAD BASE & ASPHALT PAVING – 1 TEST PER LIFT EVERY 100 LINEAL FEET.
- ALL DISTURBED AREAS NOT OTHERWISE COVERED WITH PAVEMENT, STRUCTURES OR LANDSCAPING SHALL BE HYDROSEEDDED.
- SANITARY SEWER LINES SHALL BE PVC, ASTM D 3034, SDR 35 WITH FLEXIBLE GASKETED JOINTS.

**CONTRACTOR RESPONSIBILITIES (CITY OF HAYDEN):**

THE OWNER'S CONTRACTOR SHALL:

- CONSTRUCT THE PROJECT IN CONFORMANCE WITH THE REQUIREMENTS OF THE PLANS, SPECIFICATIONS, STANDARDS, AND POLICIES.
- PROVIDE A WORK PLAN AND PROJECT SCHEDULE. SEE REQUIRED REPORTING ITEM B.
- PROVIDE A QUALIFIED SUPERINTENDENT ON SITE AT ALL TIMES THAT WORK IS BEING PERFORMED.
- KEEP CONSTRUCTION SITE AND PUBLIC ACCESS AREAS NEAT, PROPERLY SIGNED AND BARRICADED, DRAINED AND FREE OF MUD, CONSTRUCTION MATERIAL, ETC. CITY STREETS SHALL BE KEPT IN GOOD REPAIR AND ALL DUST CONTROLLED BY WATERING.
- CONTACT THE UTILITY COMPANIES TO LOCATE THE UNDERGROUND UTILITIES AND PROTECT ALL UNDERGROUND UTILITIES.
- COOPERATE FULLY WITH REPRESENTATIVES OF THE CITY, AND THE ENGINEER OF RECORD.
- PROVIDE REASONABLE ACCESS TO THE PROJECT SITE FOR CITY OF HAYDEN PERSONNEL DURING THE COURSE OF THE PROJECT. PARTICIPATE AS PART OF THE FINAL INSPECTION PROCESS.
- COORDINATE ALL ACTIVITIES WITH ANY SUBCONTRACTORS.
- CAUTION DRIVERS AND EQUIPMENT OPERATORS TO OBSERVE THE SPEED LIMITS AND NOISE RESTRICTIONS. KEEP ALL WORKERS AND EQUIPMENT WITHIN THE SUBJECT PROPERTY, RIGHT-OF-WAY AND/OR EASEMENTS.
- MAINTAIN REQUIRED TRAFFIC CONTROL. PROVIDE FOR APPROVAL AND FOLLOW THE APPROVED TRAFFIC CONTROL PLAN.
- BE RESPONSIBLE FOR HAVING A QUALITY CONTROL PROGRAM TO ENSURE MATERIALS, EQUIPMENT AND WORKMANSHIP ARE PERFORMED AND INSTALLED IN CONFORMANCE WITH THE PLANS & SPECIFICATIONS.
- THE CONTRACTOR SHALL BE RESPONSIBLE FOR MEANS, METHODS, AND SAFETY OF ALL CONSTRUCTION FOR THE PROJECT.
- PROVIDE AMPLE NOTIFICATION FOR ALL AFFECTED PROPERTY OWNERS OF CONSTRUCTION OPERATIONS THAT WILL RESTRICT OR DENY ACCESS TO THEIR PROPERTY FOR EITHER LIMITED OR EXTENDED TIME PERIODS. COMMUNICATIONS SHALL BE IN WRITING IDENTIFYING THE TYPE OF OPERATIONS, EXPECTED TIME OF INTERRUPTION OF SERVICE, EXPECTED TIME OF RESTORATION OF SERVICE, AND WHO TO CONTACT. THE MINIMUM TIME OF NOTIFICATION SHALL BE 24 HOURS PRIOR TO THE SPECIFIC OPERATION.
- PROVIDE AMPLE NOTIFICATION TO EMERGENCY SERVICES AND SCHOOL DISTRICTS IF ACCESS TO ROADWAYS IS LIMITED OR DENIED. COMMUNICATIONS MAY BE VERBAL OR IN WRITING. THE MINIMUM TIME OF NOTIFICATION SHALL BE 24 HOURS PRIOR TO THE SPECIFIC OPERATION.
- NOT START WORK BEFORE 6:00 AM ON THE WEEKDAY OR 7:00 AM ON THE WEEKEND AND NOT AFTER 9:00 PM ON THE WEEKDAY OR 6:00 PM ON THE WEEKEND, UNLESS OTHERWISE AUTHORIZED BY THE CITY COUNCIL.

**PAVING, GRADING AND DRAINAGE NOTES:**

- ASPHALT PAVEMENT SHALL CONFORM WITH IDAHO TRANSPORTATION DEPARTMENT (ITD) SPECIFICATIONS FOR SUPERPAVE. PAVEMENT SHALL BE SP3 PG 58-28 WITH 1/2" MAX AGGREGATE SIZE. PAVEMENTS WITH A SECTION OF 3" OR LESS MAY BE PLACED WITH 1 LIFT. PAVEMENTS WITH A SECTION GREATER THAN 3" SHALL BE PLACED WITH MULTIPLE LIFTS. MINIMUM LIFT THICKNESS OF 1.5" AND MAXIMUM THICKNESS OF 3".
- CRUSHED AGGREGATE BASE SHALL CONFORM TO THE IDAHO STANDARDS FOR PUBLIC WORKS CONSTRUCTION, SECTION 802, TYPE I, 3/4-INCH MAXIMUM AGGREGATE SIZE.
- AGGREGATE SUBBASE (BALLAST) SHALL CONFORM TO THE IDAHO STANDARDS FOR PUBLIC WORKS CONSTRUCTION, SECTION 802, TYPE II, 2-INCH MAXIMUM AGGREGATE SIZE.
- PRIOR TO PLACEMENT OF STRUCTURAL FILL (FOR ROADWAYS, PAVEMENT AND STRUCTURES), THE GROUND SURFACE SHALL BE PREPARED TO RECEIVE FILL BY REMOVING VEGETATION, TOPSOIL, AND ANY OTHER UNSUITABLE MATERIAL.
- STRUCTURAL FILL MATERIAL (FOR ROADWAYS, PAVEMENT AND STRUCTURES) SHALL BE COMPOSED OF NATIVE SOIL THAT IS FREE OF ORGANIC MATERIAL.
- PRIOR TO PLACING SUBBASE AND BASE MATERIAL, THE FOLLOWING SHALL BE COMPLETED:
  - UTILITIES SHALL BE INSTALLED, TESTED AND APPROVED.
  - THE CONTRACTOR SHALL PROVIDE THE ENGINEER WITH COMPACTION TEST RESULTS FOR ALL UTILITY TRENCHES AND THE SUBGRADE.
  - THE SUBGRADE SHALL BE PROOF-ROLLED, INSPECTED AND APPROVED BY THE ENGINEER AND THE CITY.
- PRIOR TO PLACING ASPHALT PAVEMENT SURFACE COURSE, THE FOLLOWING SHALL BE COMPLETED:
  - THE CONTRACTOR SHALL PROVIDE THE ENGINEER WITH COMPACTION TEST RESULTS FOR THE SUBBASE AND BASE COURSES.
  - ALL UTILITIES SHALL BE ADJUSTED TO GRADE.
  - AN ASPHALT TACK COAT SHALL BE APPLIED TO CURBS, MANHOLES, VALVE BOXES, CATCH BASINS AND ALL OTHER STRUCTURES WITHIN THE AREA TO BE PAVED.
  - OBTAIN AUTHORIZATION FROM THE ENGINEER TO PROCEED WITH PAVING.
  - UTILITIES SHALL BE COMPLETED AND PASSING TESTS SHALL BE PROVIDED AND REVIEWED BY THE CITY
- ALL BACKFILL AND EMBANKMENT MATERIAL SHALL BE COMPACTED, AND CERTIFIED COMPACTION TESTING SHALL BE PROVIDED TO THE CITY OF HAYDEN. COMPACTION SHALL BE 95% OF A STANDARD PROCTOR FOR THE EMBANKMENT/BACKFILL MATERIAL.

**AVONDALE IRRIGATION DISTRICT- NOTES FOR CONSTRUCTION:**

- ALL ADDITIONS AND/OR MODIFICATIONS TO AID SYSTEM SHALL BE DONE IN CONFORMANCE WITH I.S.P.W.C LATEST EDITION AND AID STANDARDS.
- THE CONTRACTOR MUST HAVE AN APPROVED SET OF CONSTRUCTION PLANS ON SITE AT ALL TIMES. AN APPROVED SET WILL HAVE AN ENGINEER'S STAMP AND SIGNED AID SIGNATURE BLOCK.
- ANY WATER SYSTEM CHANGES MUST BE APPROVED BY AID AND PROJECT ENGINEER PRIOR TO EXECUTING CHANGE.
- AID RESERVES THE RIGHT TO INSPECT CONSTRUCTION AT ANY TIME AND DIRECT THE CONTRACTOR TO MAKE FIELD ADJUSTMENTS AS REQUIRED.
- THE CONTRACTOR SHALL NOTIFY AID 48 HOURS PRIOR TO BEGINNING ANY CONSTRUCTION OPERATIONS AND WILL COORDINATE ALL ACTIVITIES WITH THEM.
- A RECORDED EASEMENT OF THE NEW MAINLINE EXTENSION OR WATER DELIVERY MUST BE EXECUTED AND RECORDED PRIOR TO WATER SERVICE.
- CONTRACTOR SHALL PRESERVE AND PROTECT ALL EXISTING AID SERVICES AT ALL TIMES.
- ALL ABANDONED ASBESTOS CEMENT (A/C) PIPE SHALL BE REMOVED AND PROPERLY DISPOSED OF IN AN APPROVED LOCATION.
- MINIMUM HORIZONTAL SEPARATION OF 10-FEET SHALL BE MAINTAINED WITH ALL NON-POTABLE WATER/WASTEWATER LINES.
- ALL VERTICAL POTABLE/NON-POTABLE CROSSINGS SHALL HAVE AN 18-INCH SEPARATION WITH THE POTABLE LINE ON TOP. IF THIS CANNOT BE ACHIEVED, A 20-FOOT LINEAL CASING CONSISTING OF C900-C905 TYPE PIPE MAY BE USED AND CENTERED OVER THE NON-POTABLE LINE.
- ALL MAINLINE EXTENSIONS SHALL BE C900/C905 CLASS 150 DR18 PVC.
- EXCAVATION UNDER ANY A/C PIPE SHALL RESULT IN THE SECTIONING OF THE A/C PIPE AND REPLACEMENT WITH C900/C905 THE WIDTH OF THE DITCH PLUS TWO FEET ON EACH SIDE.
- ALL MECHANICAL JOINTS AND FITTINGS SHALL BE DUCTILE IRON.
- ALL VALVES AND FITTINGS SHALL BE WRAPPED IN POLYETHYLENE PRIOR TO CONCRETE PLACEMENT.
- ALL PIPES SHALL BE BEDDED IN ACCORDANCE WITH THE APPROVED PLAN DETAIL AND INCLUDE TRACER WIRE AND WATER MARKING TAPE.
- ALL PIPES SHALL HAVE A MINIMUM COVER OF 5 FEET FROM THE TOP OF THE PIPE TO THE FINISH GRADE.
- ~~ALL MATERIALS SHALL BE NEW, AWWA APPROVED, MEET AID STANDARDS AND OF U.S. ORIGIN. NO IMPORTED MATERIALS WILL BE ALLOWED.~~
- ALL THRUST BLOCKS SHALL MEET SPECIFICATIONS CALLED OUT ON THE APPROVED PLANS AND BE POURED IN PLACE.
- ALL VALVE BOXES SHALL HAVE 2 CUBIC FEET OF WASHED DRAIN ROCK AROUND THE BOTTOM AND A SELF CENTERING BOX LOCK.
- METER BLANKS SHALL BE INSTALLED BY THE CONTRACTOR IN PLACE OF THE ACTUAL METER DURING CONSTRUCTION, UNLESS OTHERWISE STATED BY AID.
- ALL METER BOXES SHALL BE LOCATED BEHIND THE UTILITY EASEMENT ON THE OWNER'S PROPERTY UNLESS OTHERWISE APPROVED BY AID.
- IT IS THE RESPONSIBILITY OF THE CONTRACTOR TO OBTAIN THE REFERENCED STANDARDS AND PROVIDE SETS TO ALL APPLICABLE CREWS AND SUBCONTRACTORS FOR WATER SYSTEM INSTALLATION.
- WHERE A DISCREPANCY OCCURS BETWEEN THE CONSTRUCTION PLANS (PERTAINING TO WATER ONLY) AND AID STANDARDS, AID STANDARDS PREVAIL.
- AID RECOGNIZES A ONE YEAR WARRANTY OF ALL WORKMANSHIP AND PARTS STARTING WITH THE ACCEPTANCE DATE AFTER CONSTRUCTION COMPLETION.
- ALL FIRE HYDRANTS SHALL CONFORM TO THE APPROVED PLAN DETAIL AND INCLUDE A STORZ ADAPTER AND HYDRANT LOCK.
- IN CASE OF EMERGENCY CALL (208) 772-5657.

**DISINFECTION OF WATER MAINS & SERVICES**

GENERAL

- COMPLY WITH AWWA C 651.
- KEEP INTERIOR OF PIPE, FITTINGS, AND APPURTENANCES FREE OF DEBRIS AND DIRT.

TABLET METHOD OF DISINFECTION

- PLACE 5 GRAM CALCIUM HYPOCHLORITE TABLETS IN EACH SECTION OF PIPE AND ONE AT EACH FITTING.
- ADHESIVE SHALL BE NSF 61 APPROVED.
- TABLETS SHALL BE PLACED IN THE TOP HALF OF THE PIPE AND AT EACH END. MARK THEIR LOCATION ON THE TOP OF THE PIPE.
  - NUMBER OF TABLETS IS DETERMINED BY THE PIPE SIZE TO ACHIEVE THE REQUIRED CHLORINE RESIDUAL:
    - 6" – 1 TABLET
    - 8" – 2 TABLETS
    - 10" – 3 TABLETS
    - 12" – 4 TABLETS
- FILL PIPE AT A VELOCITY OF LESS THAN 1 FT/SEC
- CHLORINATED WATER SHALL REMAIN IN THE PIPE FOR AT LEAST 24 HOURS BEFORE FLUSHING. IF WATER IS LESS THAN 41 DEGREES, CHLORINATED WATER SHALL REMAIN IN PIPE FOR A MINIMUM OF 48 HOURS.

FINAL FLUSHING

- REMOVE CHLORINATED WATER IN A MANNER APPROVED BY THE WATER PURVEYOR IN AN APPROVED LOCATOIN
- FLUSH AT GREATER THAN A 3.0 FPS VELOCITY

BACTERIA TESTING

- TAKE A MINIMUM OF TWO TESTS SEPARATED BY 24 HOURS.
- SAMPLES SHALL BE COLLECTED IN STERILE BOTTLES IN ACCORDANCE WITH SECTION 9060 OF THE STANDARD METHODS FOR THE EXAMINATION OF WATER AND WASTEWATER. SAMPLES SHALL BE TESTED IN ACCORDANCE WITH THESE SAME STANDARDS BY A LICENSED TESTING LAB AND SHOW THE ABSENCE OF COLIFORM BACTERIA.
- A MINIMUM OF TWO BACK TO BACK PASSING BACTERIA TESTS MUST BE OBTAINED FROM EACH SECTION/LEG OF PIPE PRIOR TO PRESSURE TESTING WATERLINE.
- A TEST SHALL BE TAKEN FOR EVERY 1,200 FT OF NEW WATERLINE, PLUS AT LEAST ONE SAMPLE FROM EACH BRANCH GREATER THAN ONE PIPE LENGTH.

**PRESSURE TESTING REQUIREMENTS (ISPMC 401.3.6):**

- PERFORM TESTING IN THE PRESENCE OF THE ENGINEER.
- ASSURE THAT TRENCH IS PROPERLY BACKFILLED AND THRUST BLOCKING HAS CURED TO A DEGREE THAT WILL ALLOW PRESSURE TESTING WITHOUT DAMAGE, OR PIPE/FITTING MOVEMENT.
- GRADUALLY FILL PIPE WITH WATER AND SUSTAIN A TEST PRESSURE OF 150 PSI FOR A MINIMUM OF 2 HOURS
- EXPEL ALL AIR.
- VERIFY THAT, IN A TWO-HOUR TEST, THE PIPE DOES NOT LEAK IN EXCESS OF THE ALLOWABLE LEAKAGE AS DEFINED BY THE FOLLOWING FORMULA IN WHICH L IS THE ALLOWABLE LEAKAGE IN GALLONS/HOUR.

$$L = \frac{ND(P)X}{7,400}$$

WHERE: L = ALLOWABLE LEAKAGE GALLONS/HOUR  
 N = NUMBER OF JOINTS IN TESTED LINE – INCLUDING FITTINGS  
 D = NOMINAL PIPE DIAMETER INCHES  
 P = TEST PRESSURE PSI GAUGE

- PRESSURE TEST HDPE PIPE PER ASTM F 2164-02 FIELD LEAK TESTING OF POLYETHYLENE (PE) PRESSURE PIPING SYSTEMS USING HYDROSTATIC PRESSURE.

**SANITARY SEWER NOTES:**

MATERIALS

- COMPLY WITH PIPE SIZE,TYPE, AND STRENGTH CLASSIFICATION INDICATED IN THE CONTRACT DOCUMENTS.
- NOTIFY ENGINEER IF INSTALLATION CONDITIONS SUCH AS TRENCH WIDTH, DEPTH, SOILS AND BEDDING CONDITIONS DO NOT MATCH CONDITIONS CONTEMPLATED BY THE CONTRACT DOCUMENTS

GRAVITY SEWER PIPE AND FITTINGS

- SOLID WALL PVC PIPE SIZES 4 INCH TO 15 INCH: ASTM D 3034.
- MINIMUM WALL THICKNESS : SDR 35.
- JOINTS: ELASTOMERIC GASKET JOINTS WITH ASTM F 477 ELASTOMERIC GASKETS.
- COUPLING OF TWO PIPES WHERE FACTORY BELL AND SPIGOT ARE NOT AVAILABLE: FLEX SEAL COUPLERS PROVIDING FOR A WATERTIGHT CONNECTION AND A SMOOTH PIPE INVERT, AS APPROVED BY THE ENGINEER.

PIPE INSTALLATION

- ON SEWER LINE EXTENSIONS, ISOLATE HAZARDOUS GASES AND PREVENT GROUNDWATER AND OTHER MATERIAL FROM ENTERING AN EXISTING SEWER LINE BY INSTALLING A TEMPORARY AIR-TIGHT PLUG IN THE FIRST NEW MANHOLE THAT WILL NOT RESTRICT EXISTING FLOW. THE PLUG SHALL REMAIN UNTIL THE SEWER HAS BEEN ACCEPTED FOR USE.
- MAINTAIN GROUNDWATER 1 FOOT BELOW THE PIPE INVERT AND, IF NECESSARY, PROVIDE FOUNDATION STABILIZATION IN ACCORDANCE WITH SECTION 304 (ISPMC)-TRENCH FOUNDATION STABILIZATION.
- PROVIDE PIPE BEDDING AND INITIAL BACKFILL AS REQUIRED BY SECTION 305 (ISPMC)- PIPE BEDDING.
- UNLESS OTHERWISE APPROVED BY THE ENGINEER, INSTALL PIPE UPGRADE WITH THE BELL-END UPGRADE.
- PROVIDE SUFFICIENT RESTRAINT FOR THE PIPE TO ENSURE THAT JOINTS ARE HELD IN PLACE WHILE BEDDING AND INITIAL BACKFILL ARE PLACED AND WHILE THE TRENCH SHORING SYSTEM IS MOVED.
- WHEN INSTALLATION IS NOT IN PROGRESS, BLOCK AND PLUG THE OPEN END OF THE PIPE TO PREVENT CREEP, UPLIFT OR FLOATING AND ENTRANCE OF WATER OR OTHER MATERIAL INTO THE PIPE.
- SEWER SERVICE CONNECTIONS SHALL BE MADE BY A TEE BRANCH FROM A NEW MAIN CONNECTED ABOVE THE SPRING LINE OF THE PIPE. SERVICE CONNECTIONS LESS THAN 45' ABOVE HORIZONTAL SHALL BE ALLOWED ONLY WHEN APPROVED BY THE CITY ENGINEER, AND AT THOSE LOCATIONS INDICATED ON THE PLANS. SERVICE CONNECTIONS TO MANHOLES ARE PROHIBITED.
- ALL SANITARY SEWER MAINS SHALL BE SEPARATED A MINIMUM OF 10 FEET HORIZONTALLY FROM DOMESTIC WATER LINES. CROSSINGS OF WATER MAINS AND SEWER SYSTEMS SHALL HAVE A MINIMUM 18-INCH VERTICAL SEPARATION WITH THE WATER MAIN BEING CENTERED OVER THE SANITARY SEWER. ANY ANTICIPATED SEPARATION DIFFERING FROM THE MINIMUM STANDARDS CONTAINED HEREIN SHALL CONFORM TO THE IDAHO RULES FOR WASTE WATER, (IDAPA 58.01.16)

TESTING

- SEWER TESTING SHALL BE DONE IN CONFORMANCE WITH SECTION 501.3.4 OF THE IDAHO STANDARDS FOR PUBLIC WORKS CONSTRUCTION AND SHALL BE COMPLETED IN THE PRESENCE OF THE ENGINEER.
- VISUAL INSPECTION: VISUALLY INSPECT THE PIPELINE BETWEEN MANHOLES WITH MIRRORS OR LIGHTS AFTER THE TRENCH HAS BEEN BACKFILLED TO CHECK ALIGNMENT AND GRADE, AND TO CHECK FOR PIPE DISTORTIONS, LEAKS, INFILTRATION AND OTHER DEFECTS. VERIFY THAT A FULL DIAMETER OF PIPE IS VISIBLE FROM ONE MANHOLE TO THE NEXT. UNCOVER AND REPAIR LEAKS AND DEFECTS IN THE PIPELINE. DO NO REINSTALL DAMAGED PIPE.
- AIR PRESSURE TESTING: LOW PRESSURE AIR TEST LINES THAT ARE 24 INCHES AND SMALLER IN DIAMETER PRELIMINARY AND FINAL TESTING. REFER TO SECTION 501.3.4.C OF THE MOST RECENT ISPMC STANDARDS FOR FULL TESTING REQUIREMENTS.

- AT THE DISCRETION OF THE CONTRACTOR, PRELIMINARY TESTING MAY BE DONE AT ANY TIME PRIOR TO INSTALLATION OF OTHER UTILITIES.
- PERFORM FINAL TESTING AFTER BACKFILLING AND COMPACTION AND FOLLOWING OF OTHER UTILITIES, BUT PRIOR TO SURFACE RESTORATION.

PIPE CLEANING:

- PRIOR TO DEFLECTION TESTING AND CCTV INSPECTION CLEAN THE COMPLETED PIPELINE WITH A HYDRO-CLEANER OR OTHER ENGINEER APPROVED CLEANING EQUIPMENT, AND PROVIDE A PIPELINE FREE OF DIRT, MUD, ROCKS, OR OTHER MATERIAL. LEAVE DOWNSTREAM PLUGS IN PLACE DURING CLEANING AND DO NOT INTRODUCE FOREIGN MATERIAL INTO THE EXISTING SEWER LINES.

- PIPES SHALL BE CLEAN PRIOR TO FINAL ACCEPTANCE BY THE CITY.

CLOSED CIRCUIT TELEVISION (CCTV) INSPECTION

- PERFORM CCTV INSPECTION AFTER BACKFILL AND PRIOR TO SURFACE REPAIR FOR ALL PUBLIC LINES. UNCOVER AND REINSTALL SECTIONS OF THE PIPE FOUND TO HAVE DEFECTS IN WORKMANSHIP (INCLUDING STANDING WATER CAUSED BY GRADE DEFECTS) AS DIRECTED BY THE OWNER. AFTER REPAIR RE-CCTV THE REPAIRED SECTION. DO NOT REINSTALL DAMAGED OR REJECTED PIPE. CCTV INSPECTION SHALL BE COMPLETED IN CONFORMANCE WITH ISPMC SECTION 501.3.4.
- CLEAN LINES PRIOR TO CCTV INSPECTION USING HYDRO CLEANER, FLUSHING BALLS OR OTHER SUITABLE MEANS ACCEPTABLE TO ENGINEER. REMOVE DEBRIS FROM LINE RATHER THAN WASHING DOWNSTREAM.

**STORM DRAINAGE NOTES:**

MATERIALS

- SOLID WALL PVC PIPE SIZES 4 INCH TO 15 INCH: ASTM D 3034.
- MINIMUM WALL THICKNESS : SDR 35.
- ELASTOMERIC GASKET JOINTS WITH ASTM F 477 ELASTOMERIC GASKETS.
- SOLID WALL PVC PIPE SIZES 18 INCH TO 36 INCH: ASTM F679

PIPE INSTALLATION

- PREPARE TRENCH BOTTOM AS REQUIRED BY (ISPMC) SECTION 301- TRENCH EXCAVATION
- MAINTAIN GROUNDWATER 1 FOOT BELOW THE PIPE INVERT AND, IF NECESSARY, PROVIDE FOUNDATION STABILIZATION IN ACCORDANCE WITH SECTION 304 (ISPMC)-TRENCH FOUNDATION STABILIZATION.
- LIMIT VARIANCE OF INSTALLED PIPE FROM DESIGN LINE AND GRADE TO LESS THAN 0.02 FEET, UNLESS A SMALLER VARIANCE IS NECESSARY TO PREVENT A LEVEL OR NEGATIVE SLOPE
- BACKFILL TRENCH AS REQUIRED BY (ISPMC) SECTION 306- TRENCH BACKFILL
- STORM SEWER PIPES AND DRYWELLS SHALL BE SEPARATED A MINIMUM OF 10 FEET HORIZONTALLY FROM DOMESTIC WATER MAINS. CROSSINGS OF WATER MAINS AND SEWER SYSTEMS SHALL HAVE A MINIMUM 18-INCH VERTICAL SEPARATION. ANY ANTICIPATED SEPARATION LESS THAN MINIMUM STANDARDS CONTAINED HEREIN, SHALL CONFORM TO THE IDAHO RULES FOR WASTE WATER, (IDAPA 58.01.16)

TESTING



- PERFORM TESTING IN THE PRESENCE OF THE ENGINEER
- FOR PIPES 24 INCHES AND SMALLER, TEST PER ISPMC SECTION 501- GRAVITY SEWERS

PLACEMENT OF BEDDING

- PLACE A MINIMUM OF 4 INCHES OF COMPACTED BEDDING ON PREPARED SUBGRADE AS SPECIFIED IN ISPMC SECTION 305- PIPE BEDDING. EXTEND BEDDING EITHER TO THE LIMITS OF THE EXCAVATION OR AT LEAST 12 INCHES OUTSIDE THE LIMITS OF THE BASE SECTIONS
- FILL THE BALANCE OF THE EXCAVATED AREA WITH SELECTED MATERIAL COMPACTED LEVEL TO THE TOP OF THE BEDDING.

SOILS, VEGETATION AND EROSION CONTROL

- TEMPORARY EROSION CONTROL AND WATER POLLUTION MEASURES SHALL BE INSTALLED, IN ACCORDANCE WITH THE PLANS AND ACCEPTED BEST MANAGEMENT PRACTICES. ADJUSTMENTS TO ACCOMMODATE DIFFERING FIELD CONDITIONS SHALL BE MADE, AS NECESSARY, THROUGHOUT THE CONSTRUCTION PROCESS. AT NO TIME, WILL SILTS AND/OR DEBRIS BE ALLOWED TO DRAIN INTO AN EXISTING OR NEWLY INSTALLED FACILITY.
- ALL DISTURBED AREAS SHALL BE HYDRO SEEDED OR SODDED, AS INDICATED ON THE PLANS. SEEDED AREAS WILL NOT BE ACCEPTED UNTIL THE SEED HAS GERMINATED, AND THE GRASS IS THOROUGHLY ESTABLISHED. SODDED AREAS WILL NOT BE ACCEPTED UNTIL THE ROOTS HAVE TAKEN HOLD, AND THE GRASS HAS RECEIVED TWO CUTTINGS.

 <p>Know what's below. Call before you dig.</p>	 <p>Olson Engineering 1649 N. Nicholson Center St. Suite #102 Post Falls, ID 83854 208-651-4152 eo@oeceivil.com</p>	PRELIMINARY
<b>MONAGHAN ESTATES</b>		
loc: <b>751 E HONEYSUCKLE AVE HAYDEN, ID</b>		
sht: <b>GENERAL NOTES</b>		
#	DATE	REVISION

c:\users\calvin\olson\_engineering\olson\_engineering - projects\2025\25072 - aspen homes honeysuckle subdivision\dwg\plans\25072 - c3.dwg

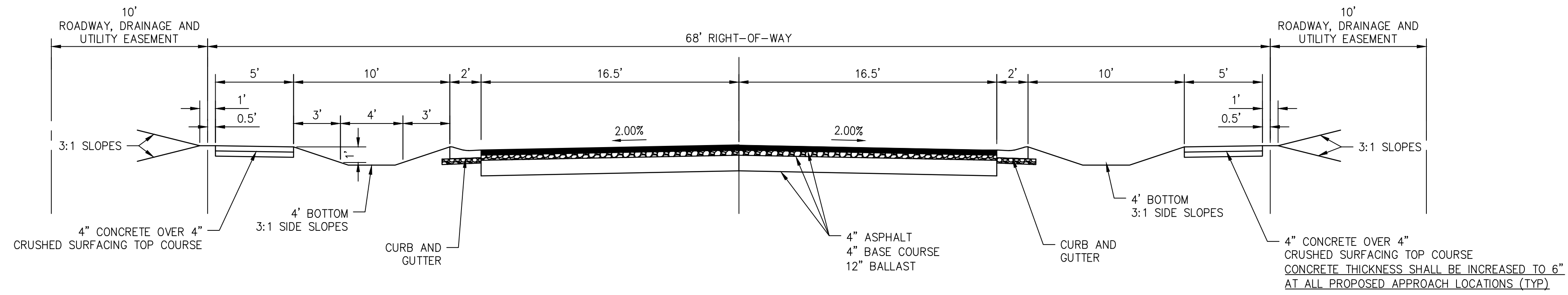

1 TYPICAL SECTION - N SECTARIATE STA: 13+86 TO 17+00  
 ROAD A STA: 10+44 TO 13+01 - 14+15 TO 14+49 -  
 15+39 TO 15+44  
 1" = 5'

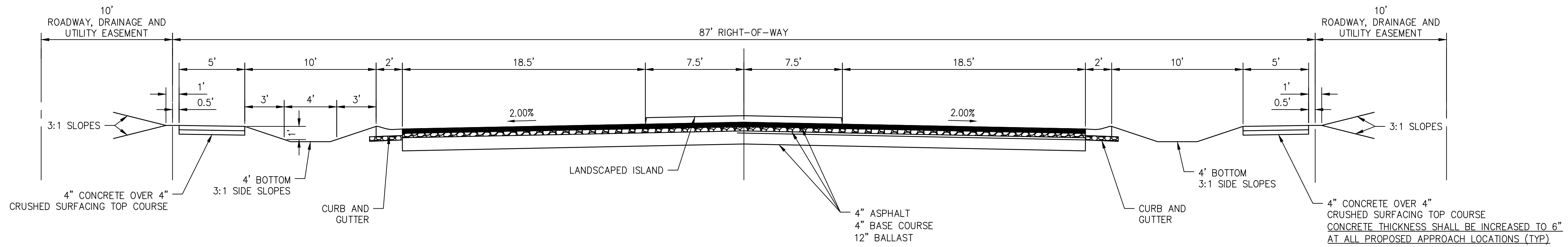

2 N SECTARIATE LN. SECTION - STA 10+46.28 - 13+37.58  
 1" = 5'



Olson Engineering  
 1649 N. Nicholson  
 Center St. Suite #102  
 Post Falls, ID 83854  
 208-651-4152  
 eo@oecivil.com

PRELIMINARY

prj: MONAGHAN ESTATES

loc: 751 E HONEYSUCKLE AVE  
 HAYDEN, ID

sht: TYPICAL SECTIONS

#	DATE	REVISION

C-3

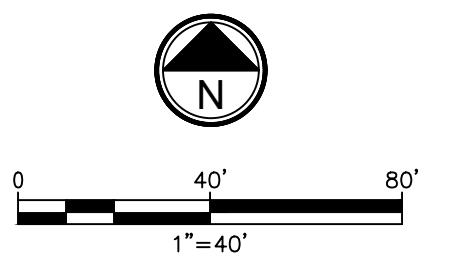

**NOTES**  
 ALL EXISTING STRUCTURES AND CONCRETE TO BE DEMOLISHED

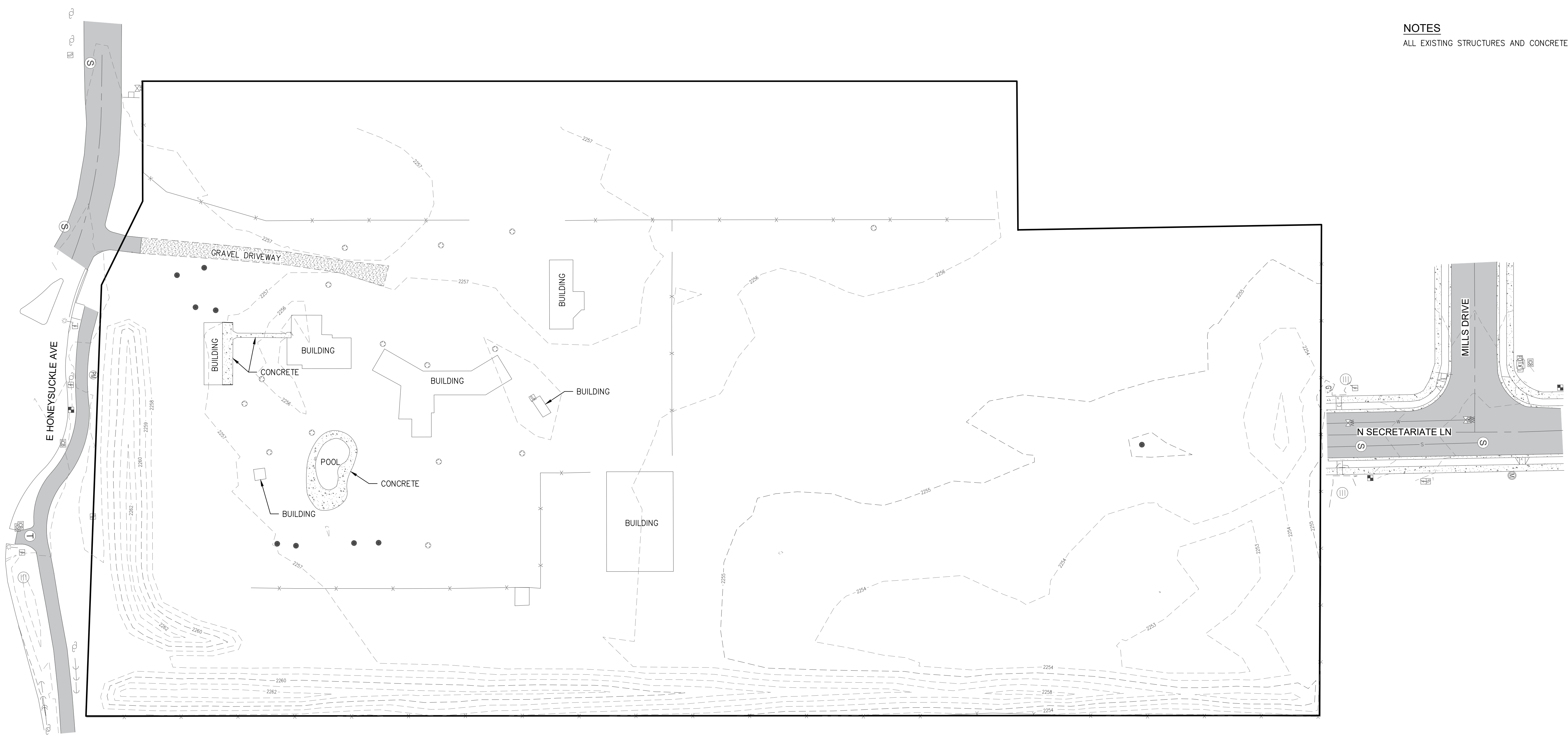

c:\users\calvin\olson\_engineering\olson\_engineering - projects\2025\25072 - aspen homes honeysuckle subdivision\dwg\plans\25072-c4.dwg

**811** Know what's below. Call before you dig.

**Olson Engineering**  
 1649 N. Nicholson  
 Center St. Suite #102  
 Post Falls, ID 83854  
 208-651-4152  
 eo@oecivil.com

**PRELIMINARY**

PROJECT: MONAGHAN ESTATES  
 LOCATION: 751 E HONEYSUCKLE AVE HAYDEN, ID  
 SHEET: EXISTING CONDITIONS

#	DATE	REVISION

**C-4**

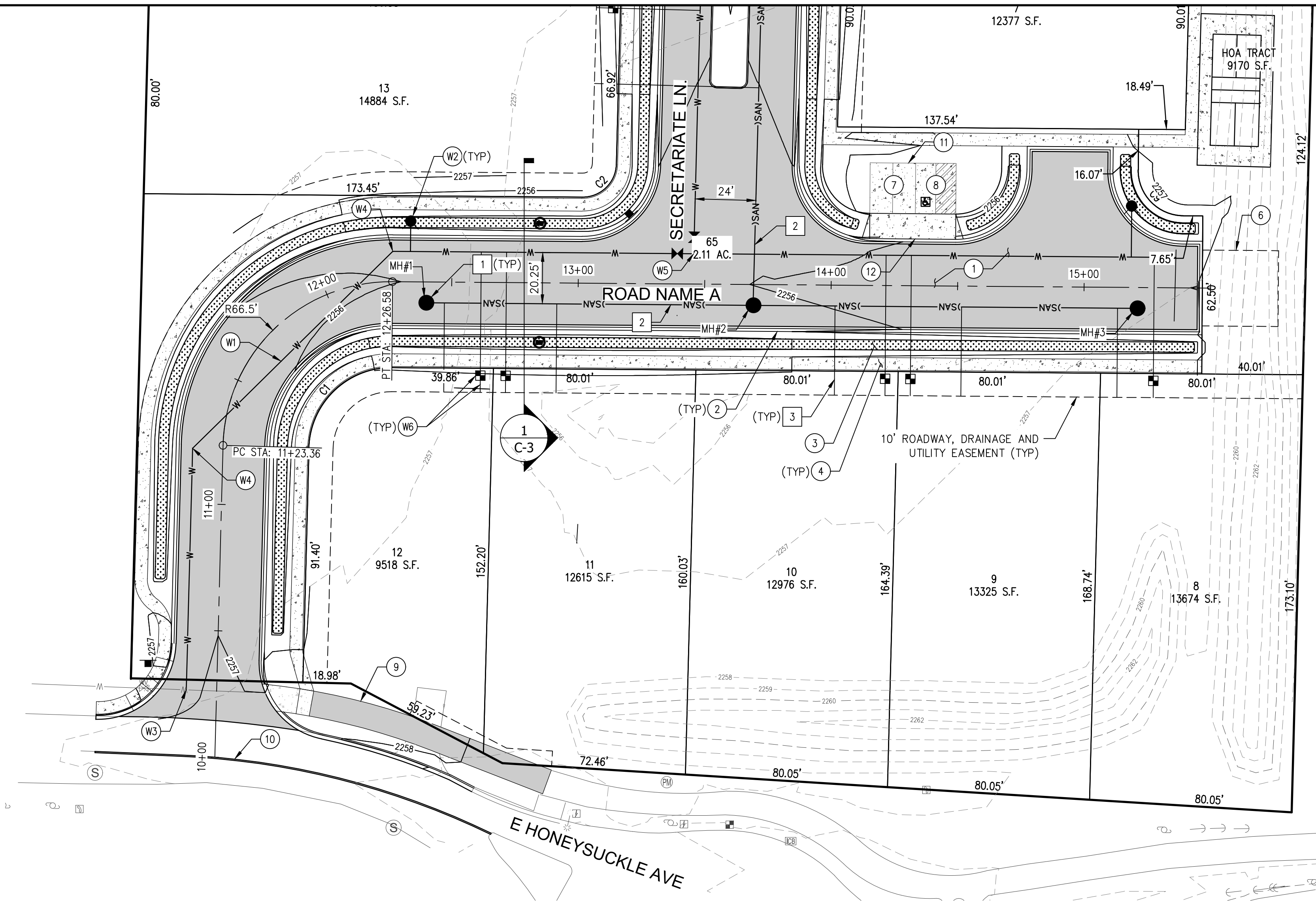

**PLAN - ROAD A**  
SCALE: 1" = 50'

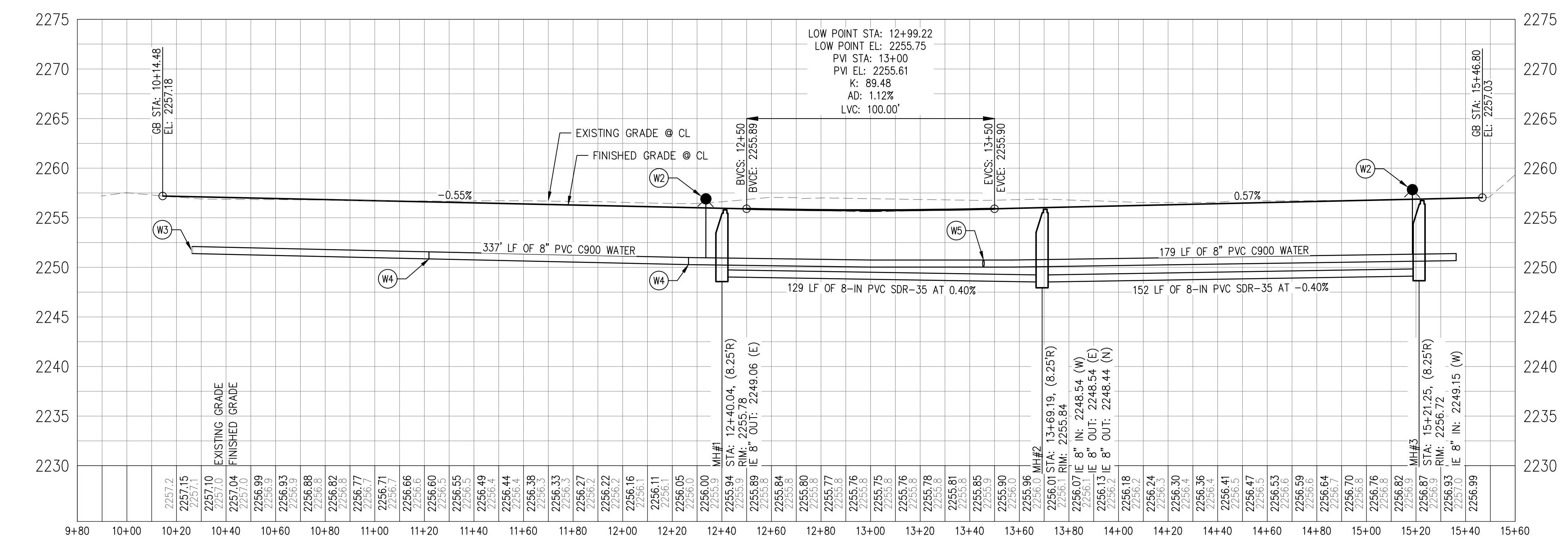

**PROFILE - ROAD A**

SCALE H: 1" = 30'  
V: 1" = 10'

**KEYNOTES**

- 1 4" HOT MIX ASPHALT OVER 4" CRUSHED AGGREGATE BASE OVER 12" BALLAST
- 2 CURB AND GUTTER PER DETAIL X, SHEET C-X
- 3 GRASS SWALE PER DETAIL X, SHEET C-X
- 4 5' CONCRETE SIDEWALK PER DETAIL X, SHEET C-X
- 5 SINGLE DEPTH DRYWELL PER DETAIL X, SHEET C-X, REFERENCE DRYWELL TABLE ON THIS SHEET
- 6 30'X30' SNOW STORAGE
- 7 (2) 9' PARKING STALLS
- 8 INSTALL VAN ACCESSIBLE ADA PARKING AND SIGNS PER DETAIL X, SHEET X
- 9 CONSTRUCT CLASS 1 PATH, PER DETAIL X, SHEET X
- 10 CONSTRUCT 6" CURB, PER DETAIL X, SHEET X
- 11 CONCRETE PARKING AREA
- 12 CONSTRUCT DRIVEWAY APPROACH, PER DETAIL X, SHEET X

**WATER KEYNOTES**

- W1 8" PVC C900 WATER MAIN
- W2 FIRE HYDRANT PER DETAIL X, SHEET C-X
- W3 TIE INTO EXISTING AID 8" WATER STUB
- W4 INSTALL 45° BEND AND THRUST BLOCK PER DETAIL X, SHEET C-X
- W5 INSTALL TEE, (2) GATE VALVES (W, N) AND THRUST BLOCK PER DETAIL X, SHEET C-X
- W6 1" HDPE WATER SERVICE AND METER BOX/SETTER PER DETAIL X, SHEET C-X

**SEWER KEYNOTES**

- 1 SANITARY MANHOLE WITH THICKENED COLLAR PER CITY DETAIL S-001 AND S-002, SHEET C-X
- 2 8" SDR-35 PVC SANITARY SEWER MAIN
- 3 4" SANITARY SEWER SERVICE PER DETAIL S-005 SEE SHEET C-X

**NOTES**

- 1) EXISTING AND PROPOSED CONTOURS ARE SHOWN AT 1' INTERVALS.
- 2) ALL BENDS AND TEES SHALL HAVE THRUST BLOCKS. REFERENCE HLID DETAIL
- 3) ALL WATER MAINS SHALL BE INSTALLED AT A MINIMUM BURY OF 5'
- 4) WATER AND SEWER LINES MUST MAINTAIN A MINIMUM OF 10' HORIZONTAL SEPARATION EXCEPT AT CROSSINGS PER DETAIL W-7, SHEET C-X
- 5) IF 18" OF VERTICAL SEPARATION CANNOT BE MAINTAINED AT CROSSINGS, THE WATER LINE OR SEWER LINE MUST BE SLEEVED PER IDEQ REQUIREMENTS

**811** Know what's below. Call before you dig.

**Olson Engineering**  
1649 N. Nicholson  
Center St. Suite #102  
Post Falls, ID 83854  
208-651-4152  
eo@oeceivil.com

PRELIMINARY

---

prj: **MONAGHAN ESTATES**

---

751 E HONEYSUCKLE AVE  
HAYDEN, ID

---

sht: **ROAD A  
PLAN AND PROFILE  
STA 10+00 TO 15+50**

#	DATE	REVISION

C-5

c:\users\calvin\olson\_engineering\olson\_engineering - projects\2025\25072 - aspen homes honeysuckle subdivision\dwg\plans\25072-c5.dwg

c:\users\calvin\olson\_engineering\projects\2025\25072 - aspen homes honeysuckle subdivision\dwg\plans\25072-c6.dwg

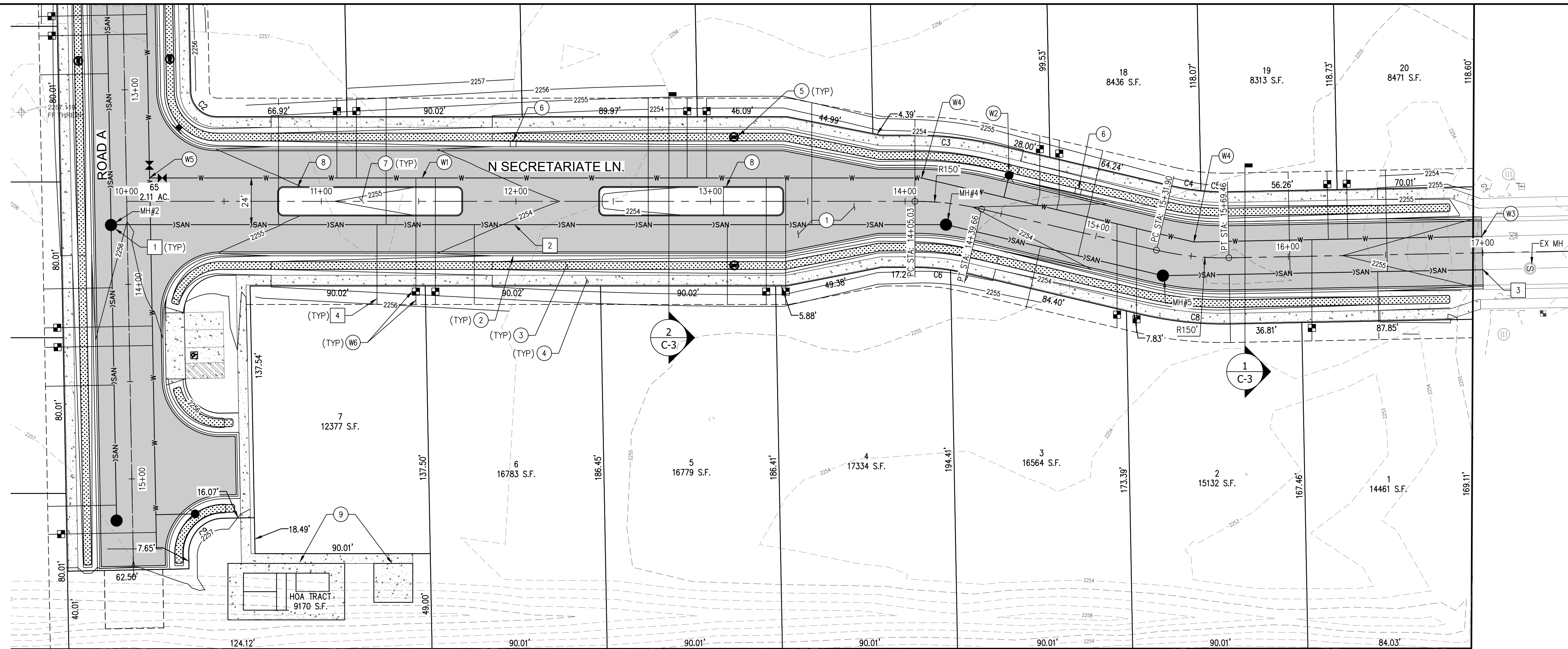

PLAN - E SECRETARIATE LN.  
SCALE: 1" = 50'

- KEYNOTES**
- 4" HOT MIX ASPHALT OVER 4" CRUSHED AGGREGATE BASE OVER 12" BALLAST
  - CURB AND GUTTER PER DETAIL X, SHEET C-X
  - GRASS SWALE PER DETAIL X, SHEET C-X
  - 5' CONCRETE SIDEWALK PER DETAIL X, SHEET C-X
  - SINGLE DEPTH DRYWELL PER DETAIL X, SHEET C-X, REFERENCE DRYWELL TABLE ON THIS SHEET
  - 3'X3' CONCRETE PAD WITH (1) 12-UNIT MAILBOX CLUSTERS
  - LANDSCAPE ISLAND
  - CONSTRUCT 6" CURB, PER DETAIL X, SHEET C-X
  - COMMUNITY PAVILION AND PICKL BALL COURT ON HOA TRACT

- WATER KEYNOTES**
- 8" PVC C900 WATER MAIN
  - FIRE HYDRANT PER DETAIL X, SHEET C-X
  - TIE INTO EXISTING AID 8" WATER STUB
  - INSTALL 11.25" BEND AND THRUST BLOCK PER DETAIL X, SHEET C-X
  - INSTALL TEE, (2) GATE VALVES (W, N) AND THRUST BLOCK PER DETAIL X, SHEET C-X
  - 1" HDPE WATER SERVICE AND METER BOX/SETTER PER DETAIL X, SHEET C-X

- SEWER KEYNOTES**
- SANITARY MANHOLE WITH THICKENED COLLAR PER CITY DETAIL S-001 AND S-002, SHEET C-X
  - 8" SDR-35 PVC SANITARY SEWER MAIN
  - TIE INTO EXISTING 8" SEWER STUB 25' SOUTH OF EXISTING MANHOLE. APPROXIMATE IE: 2245.31. CONTRACTOR TO VERIFY ELEVATION IN THE FIELD PRIOR TO SEWER INSTALLATION
  - 4" SANITARY SEWER SERVICE PER DETAIL S-005 SEE SHEET C-X

- NOTES**
- EXISTING AND PROPOSED CONTOURS ARE SHOWN AT 1' INTERVALS.
  - ALL BENDS AND TEES SHALL HAVE THRUST BLOCKS. REFERENCE HLD DETAIL
  - ALL WATER MAINS SHALL BE INSTALLED AT A MINIMUM BURY OF 5'
  - WATER AND SEWER LINES MUST MAINTAIN A MINIMUM OF 10' HORIZONTAL SEPARATION EXCEPT AT CROSSINGS PER DETAIL W-7, SHEET C-X
  - IF 18" OF VERTICAL SEPARATION CANNOT BE MAINTAINED AT CROSSINGS, THE WATER LINE OR SEWER LINE MUST BE SLEEVED PER IDEQ REQUIREMENTS

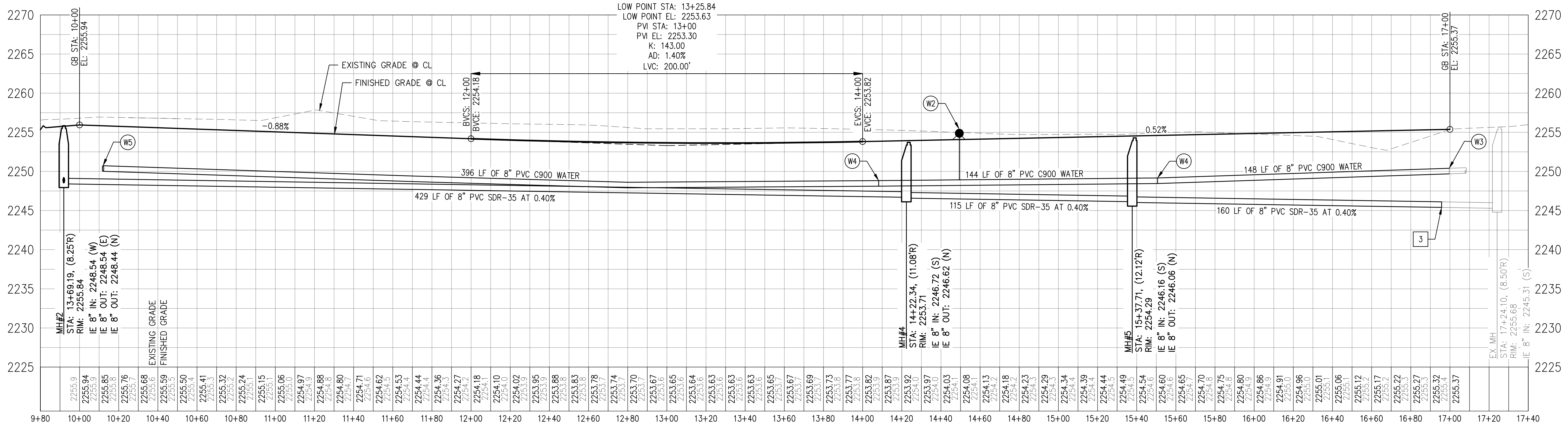

PROFILE - N SECTARIATE LN.  
SCALE H: 1"=30'  
V: 1"=10'

**811** Know what's below. Call before you dig.

**Olson Engineering**  
1649 N. Nicholson  
Center St. Suite #102  
Post Falls, ID 83854  
208-651-4152  
eo@oeccivil.com

**PRELIMINARY**

prj: **MONAGHAN ESTATES**

751 E HONEYSUCKLE AVE  
HAYDEN, ID

sht: **E SECTARIATE LN  
PLAN AND PROFILE  
STA 10+00-17+24**

#	DATE	REVISION

**C-6**

# Public Agency Comments

**Sadie Roe**

---

**From:** Bob Chandler <bobchandlercda@gmail.com>  
**Sent:** Tuesday, April 14, 2026 6:55 PM  
**To:** Planning  
**Subject:** Agency Notice for PZE-26-0035 Monaghan Estates Subdivision

Avondale has provided a Will Serve for this project and has no further comments.

Thanks,  
B.

**Bob Chandler** | District Manager  
**Avondale Irrigation District**

PO Box 81, Hayden, ID 83835  
P (208) 772-5657 | M (208) 691-3428

## Sadie Roe

---

**From:** Robert Beachler <Robert.Beachler@itd.idaho.gov>  
**Sent:** Wednesday, April 15, 2026 6:22 AM  
**To:** Planning  
**Subject:** RE: Agency Notice for PZE-26-0035 Monaghan Estates Subdivision

No Comment from the Idaho Transportation Department.

Robert Beachler  
District 1 Planning Program Manager  
Idaho Transportation Department  
600 W. Prairie Ave  
Coeur d'Alene, ID 83815  
[robert.beachler@itd.idaho.gov](mailto:robert.beachler@itd.idaho.gov)  
(208) 772-1216  
Office Hours M-TH 6-4:30

---

**From:** CITY OF HAYDEN - Community Development <noreply@bsacloud.com>  
**Sent:** Tuesday, April 14, 2026 3:21 PM  
**To:** Robert Beachler <Robert.Beachler@itd.idaho.gov>  
**Subject:** Agency Notice for PZE-26-0035 Monaghan Estates Subdivision

**CAUTION: This email originated outside the State of Idaho network. Verify links and attachments BEFORE you click or open, even if you recognize and/or trust the sender. Contact your agency service desk with any concerns.**

---

Good Afternoon,

Attached you will find the Agency Notice for a major subdivision: Monaghan Estates currently known as: 751 E Honeysuckle Avenue. Please submit any written comments by April 28th to be included in the Staff Analysis. You may email your comments to: [Planning@haydenid.gov](mailto:Planning@haydenid.gov)

If you have no comments, please advise us accordingly.

Thank you!

Sincerely,

Sadie Roe

Planning Assistant

## Sadie Roe

---

**From:** Corey Koerner <ckoerner@phd1.idaho.gov>  
**Sent:** Thursday, April 16, 2026 1:00 PM  
**To:** Planning  
**Subject:** PZE-26-0036

**Categories:** Sadie

Hello,

In regards to PZE-26-0036, PHD has the following comments:

A complete subdivision application must be submitted to the health district and all fees paid. All requirements of PHD's subdivision process must be complete prior to final plat approval.

Thank you.

Corey Koerner, REHS  
Registered Environmental Health Specialist  
Panhandle Health District 1  
8500 N. Atlas Road  
Hayden, ID 83835  
O: (208) 415-5215  
C: (208) 819-0411  
[Ckoerner@phd1.idaho.gov](mailto:ckoerner@phd1.idaho.gov)

## Sadie Roe

---

**From:** Scott Maxwell <[smaxwell@kcgov.us](mailto:smaxwell@kcgov.us)>  
**Sent:** Thursday, April 16, 2026 11:19 AM  
**To:** Planning  
**Subject:** PZE-26-0035

**Categories:** Sadie

You don't often get email from [smaxwell@kcgov.us](mailto:smaxwell@kcgov.us). [Learn why this is important](#)

The KCSO has no issues or concerns at the is time.

Thanks,

Captain Scott Maxwell

**From:** CITY OF HAYDEN - Community Development <[noreply@bsacloud.com](mailto:noreply@bsacloud.com)>  
**Sent:** Tuesday, April 14, 2026 3:21 PM  
**To:** Scott Maxwell <[smaxwell@kcgov.us](mailto:smaxwell@kcgov.us)>  
**Subject:** Agency Notice for PZE-26-0035 Monaghan Estates Subdivision

Good Afternoon,

Attached you will find the Agency Notice for a major subdivision: Monaghan Estates currently known as: 751 E Honeysuckle Avenue. Please submit any written comments by April 28th to be included in the Staff Analysis. You may email your comments to: [Planning@haydenid.gov](mailto:Planning@haydenid.gov)

If you have no comments, please advise us accordingly.

Thank you!

Sincerely,

Sadie Roe

Planning Assistant

## Sadie Roe

---

**From:** Richman, Michelle <Michelle.Richman@idwr.idaho.gov>  
**Sent:** Friday, April 17, 2026 9:21 AM  
**To:** Planning  
**Subject:** FW: Agency Notice for PZE-26-0035 Monaghan Estates Subdivision  
**Attachments:** PZE-26-0035 - Agency Notice 04-14-26.pdf

**Categories:** Sadie

Hello,

Thank you for the opportunity to comment. It is IDWR's understanding that Avondale Irrigation District will be supplying water to this new subdivision. IDWR has no concerns with the proposal; however, it appears North Kootenai may notate the property as being in their service area too. This is just for your information.

Thanks,  
Michelle

---

**From:** CITY OF HAYDEN - Community Development <noreply@bsacloud.com>  
**Sent:** Tuesday, April 14, 2026 3:21 PM  
**To:** Richman, Michelle <Michelle.Richman@idwr.idaho.gov>  
**Subject:** Agency Notice for PZE-26-0035 Monaghan Estates Subdivision

**CAUTION: This email originated outside the State of Idaho network. Verify links and attachments BEFORE you click or open, even if you recognize and/or trust the sender. Contact your agency service desk with any concerns.**

---

Good Afternoon,

Attached you will find the Agency Notice for a major subdivision: Monaghan Estates currently known as: 751 E Honeysuckle Avenue. Please submit any written comments by April 28th to be included in the Staff Analysis. You may email your comments to: [Planning@haydenid.gov](mailto:Planning@haydenid.gov)

If you have no comments, please advise us accordingly.

Thank you!

Sincerely,

Sadie Roe

Planning Assistant

## Sadie Roe

---

**From:** Horsmon, Merritt <merritt.horsmon@idfg.idaho.gov>  
**Sent:** Thursday, April 30, 2026 12:40 PM  
**To:** Planning  
**Subject:** PZE-26-0035 - Monaghan Estates

The Idaho department of Fish and Game does not have any comments to submit for this project.

Thank you for the opportunity to review and comment.

### **Merritt Horsmon**

Regional Technical Assistance Manager  
Panhandle Region  
2885 W. Kathleen Ave.  
Coeur d'Alene, ID 83815  
208.769.1414 office  
208.251.4509 mobile  
[merritt.horsmon@idfg.idaho.gov](mailto:merritt.horsmon@idfg.idaho.gov)

