



Mr. Koester--

Thank you for the opportunity to provide a proposal in response to your RFP.

I want to highlight 3 items that display King Solar's ability to provide a successful project for USD 413.

1. **Safe harbor complete:** King Solar already owns sufficient quantities of solar panels to safe harbor projects like yours. This inventory is stored at our warehouse in Yoder, KS. Upon notice of award and receipt of down payment, ownership will be transferred to the district via a letter of title. There is no risk of delivery delays or pricing changes affecting the viability of your tax credit (direct pay).
2. **Fully bondable:** King Solar is fully bondable for the entirety of this project. Splitting the project into sub-projects for bonding may complicate the tax credit/safe harboring, therefore King Solar's pricing includes a P&P bond for the entire project.
 - **Bonding option:** King Solar's Payment & Performance bond for this project totals \$39,066. This cost is only beneficial to the district in the event that King Solar fails to perform. If desired by the district, we offer a \$39,066 discount. In exchange, we propose a 30% retainage on all invoices payable only when all sites are fully operational. This saves the district substantial cash and achieves the goal of holding King Solar to our obligations while having a substantial cash reserve (approximately \$720,000) to remedy any shortfall.
3. **Third-party ownership option:** In addition to providing the requested cash purchase option we are including an option for a 3rd party ownership arrangement through Brightwell (**see Appendix T.**).

Advantages of utilizing Brightwell:

- No upfront capital required
- Project is cashflow positive from day-1
- No additional paperwork for tax credits
- Solar production is guaranteed for the term of the agreement
- Operations & Maintenance services provided for the term of the agreement
- System is insured for the term of the agreement
- Flexible buy-out options starting at year 6

Disadvantages of utilizing a Brightwell:

- The district does not own the equipment during the term of the agreement
- The system sizes are sized slightly smaller to fit Brightwell's funding model

Respectfully submitted,

A handwritten signature in black ink, appearing to read "Mark Horst".



Mark Horst
President, King Solar Inc.
316-265-8568



Table of Contents

Page 1: Section 6.2 – Executive summary

Page 2: Section 6.3 – Technical proposal

Page 4: Section 6.4 – Pricing proposal – site specifics

Page 8: Section 6.5 – Qualifications

Page 9: Project references

Page 10: King Solar’s project team org chart

Page 11: Litigation disclosure statement

Page 12: Appendix A. Site data, and Appendix B. Pricing Forms

Page 14: Appendix C. Required Certifications

Page 15: Appendix D. Performance Guarantee

Page 16: Appendix E. Site aerials, and Appendix F. City of Chanute generator interconnection application

Page 17: Appendix G. Example line diagram

Page 18: Appendix H. Spec sheets

Page 39: Appendix I. Example photos

Page 42: Appendix J. Calibrated pile testing methodology

Page 43: Appendix K. Monthly site production details

Page 48: Appendix L. Proposed construction schedule

Page 49: Appendix M. Example safe harbor inventory allocation letter

Page 50: Appendix N. O&M service details

Page 51: Appendix O. King Solar insurance documentation (ACORD)

Page 52: Appendix P. Bid Bond

Page 55: Appendix Q. Racking domestic content verification

Page 58: Appendix R. Mark Horst’s NABCEP certificate

Page 59: Appendix S. King Solar major licenses

Page 62: Appendix T. Brightwell 3rd party ownership packets

- T.1 – High School A – Welding shop
- T.2 – High School B – West feeder
- T.3 – High School C – East feeder
- T.4 – Elementary
- T.5 – Middle School

Section 6.2 – Executive summary (Required Table)

Summary — All Meters (Required Outputs per Addendum No. 1)

Metric	HS-A (Weld)	HS-B (West)	HS-C (East)	Elementary	Middle School	Combined
System Size DC (kW)	96.0	360.0	156.0	430.0	260.0	1,302
System Size AC (kW)	72.0	264.0	120.0	330.0	200.0	986
Year-1 Production (kWh)	142,337	533,644	227,671	637,465	367,148	1,908,265
Year-1 Modeled Offset	80.2%	58.5%	62.8%	67.6%	52.9%	61.8%
25-Year Cumulative Production (kWh)	3,352,883	12,570,492	5,363,007	15,016,095	8,648,520	44,950,998
Total Installed Cost (TIC, \$)	\$187,531	\$709,562	\$305,440	\$741,006	\$452,254	\$2,395,793
ITC (30%) (\$)	\$56,259	\$212,869	\$91,632	\$222,302	\$135,676	\$718,738
Domestic Content Bonus (10%) (\$)	\$18,753	\$70,956	\$30,544	\$74,101	\$45,225	\$239,579
Net Cost after 30% ITC (\$)	\$131,272	\$496,693	\$213,808	\$518,704	\$316,578	\$1,677,055
Net Cost after 40% (\$)	\$112,519	\$425,737	\$183,264	\$444,604	\$271,352	\$1,437,476
Simple Payback at Net 40% (years)	6.9	7.0	6.9	6.0	6.3	6.5
25-Year NPV (\$)	\$152,302	\$565,280	\$251,184	\$764,608	\$421,044	\$2,154,418
25-Year IRR (%)	13.9%	13.74%	13.98%	15.88%	14.98%	see per-meter
Net LCOE (\$/kWh)	\$0.0726	\$0.0731	\$0.0739	\$0.0656	\$0.0694	\$0.0320
\$/W-DC	\$1.95	\$1.97	\$1.96	\$1.72	\$1.74	\$1.84
\$/W-AC	\$2.60	\$2.69	\$2.55	\$2.25	\$2.26	\$2.43
10-Year O&M Option (\$)	\$15,360	\$57,600	\$24,960	\$68,800	\$41,600	\$208,320

On the following pages you will find King Solar’s full response to the RFP. While we attempted to thoroughly explain all aspects of the project, there may be items that require additional clarity. Please don’t hesitate to reach out with questions:

Mark Horst, President/Core projects

mark@kingsolar.net

office: 316-265-8568 ext 9

cell: 316-300-6077

Section 6.3 – Technical Proposal

Below you will find site-by-site system summaries. Highlighted colors are consistent per site throughout. All 5 locations will be interconnected in a similar fashion as shown by the line diagram included as appendix G. The solar panels installed for each individual site will be mixed to maximize cost effectiveness while still maintaining the required domestic content to justify the additional 10% tax credit (direct pay). Because of the treasury tables the module mix will vary per site. The primary module utilized will be a Heliene 535w DOMESTIC CELL model attached in appendix H. Other modules used will also meet or exceed the requirements of the RFP or will be approved by the district prior to installation. The production model reports for each site are attached as appendix K.

Any roof mounted solar panels will be attached using one of two methodologies. Standing seam roof sections will be attached using an S-5 clamp appropriate for the specific seam and an aluminum rail system. (See example cut sheet attached in appendix H.) Flat roof sections will be installed using a non-penetrating ballasted mounting method. (See example photo attached in appendix I.) All site designs, regardless of attachment method will be evaluated and stamped by a licensed structural engineer prior to construction to verify existing roof structures can support the solar panels in addition to the code required loads.

Ground mounted solar panels will utilize a pile driven system with I-beams driven to approximately 8ft embedment. A random set of piles at each location will be tested for stability prior to racking completion using a calibrated dynamometer. See example testing methodology photos attached as appendix J. All necessary trenching/boring, concrete cutting/repair and sprinkler line repair is included in the proposal. King Solar will attempt to minimize disturbance, but will not be held liable for damage to lawn or foliage due to trenching, backfill or equipment traffic. King Solar will coordinate locating all public utilities prior to excavation. It is the responsibility of the district to locate any and all private utility lines or other sub terranean obstructions prior to construction.

All racking will be sourced and documented utilizing the appropriate amount of domestic content to justify the 10% bonus tax credit (direct pay). See domestic racking details attached as appendix Q.

Interconnection is one item that can be a hurdle on projects of this scope. Per the RFP, the City utility has confirmed there is adequate capacity, however, in our experience these sizes of projects can trigger greater scrutiny than a typical installation. It is our experience that all hurdles can be overcome with open and honest conversation with the utility, however, it may be required to adjust system size per utility request. Upon notice of award, King Solar will begin the formal design and engineering followed by utility interconnection applications. Utility fees will be paid by King Solar and any necessary pre-interconnection studies will be completed by the utility. Kansas statute dictates that utilities shall process applications within 90-days. King Solar will submit these applications on behalf of the district to the utility in the late summer of 2026 which gives plenty of time to secure approval for PTO by August of 2027 (see construction schedule attached as appendix L).

King Solar has secured inventory that more than satisfies the 50% Domestic Content requirements for the bonus 10% tax credit (direct pay). Due to the nature of the 50% Domestic Content requirements this also inherently ensures that this project also exceeds the 40% non-FEOC components required for the base 30% tax credit (direct pay).

THIS SECTION IS IMPERATIVE. In order to safe harbor your project the district must pay at least 5% of the project total and take title of at least 5% of the physical materials prior to July 4th. As mentioned on our cover letter, King Solar already has this inventory in our warehouse so as soon as we receive payment, we will send a letter of transfer to prove that the district owns the required inventory. This letter will include photos of the actual solar panels owned by the district and the corresponding serial numbers for tracking purposes. See an example letter attached as appendix M. We have structured our proposal with a 10% down payment to ensure there is some buffer built into the safe harbor model including allocating more than 5% of the materials owned by the district.

All systems will be tested prior to city inspection to ensure functionality. Commissioning and documentation of startup performance will be done utilizing standard industry practices and include the following for all inverters at all sites:

- AC voltage at each inverter. Line-to-line and Line-to-Neutral
- “Resting” DC voltage of each string. On the ground mounted arrays this will be open circuit voltage, for the roof mounts it will be the “Safe-DC” voltage or “Rapid Shutdown” voltage
- Photos or screenshots of each inverter’s active production at time of commissioning
- Voltage-to-ground on all phase conductors and DC home-run circuits
- Curve tracing, Insulation Resistance testing, and thermal imaging can be provided upon request

In addition to the construction labor, King Solar will provide a free preventative maintenance inspection 12-months after commissioning. The scope of this inspection is outlined in appendix N. Additional years are available and billed at \$16 per kW of DC capacity per year. In the pricing guide the O&M is listed as a bulk price for years 1-10, however, if the district prefers to choose inspections at ONLY years 5 and 10 (2 inspections), then the O&M pricing should be reduced accordingly. Any future preventative maintenance desired shall be paid for in conjunction with the final construction payment. If O&M services are not purchased along with the original contract, they may be added at a later date and will be billed at King Solar’s current labor rate at the time services are performed.

Finally, we have included a proposed construction schedule that ensures completion prior to August, 2027 (see appendix L attached). You’ll notice there are 12-weeks of “buffer” spread throughout the schedule as it is our experience that something always “comes up”. One of King Solar’s core values is *Honesty: we do what we say*. So, while it’s possible and maybe even likely that we’ll finish early, we want to make sure we have buffer built in the schedule to ensure we don’t miss the mark.

6.4 Pricing Proposal – Site specifics

- **HS-A HS Welding Shop – 25-0765-00-B / 97717266 - \$187,531**

- 96kWdc/72kWac ground mount (exact layout is approximate and can be adjusted per district request prior to construction)
- 3 x Fronius Symo 24.0-3 inverters (or similar)
- Includes new chain link fence around ground mounted array, or appropriate guarding per city inspector (may be combined with HS-B system shown below)
- 80% annual electrical offset



- **HS-B HS West Feeder – 25-0765-00-B / 93366572 - \$709,562**

- 360kWdc/264kWac ground mount (exact layout is approximate and can be adjusted per district request prior to construction)
- 11 x Fronius Symo 24.0-3 inverters (or similar)
- Includes new chain link fence around ground mounted array, or appropriate guarding per city inspector
- 58% annual electrical offset



- **HS-C HS East Feeder – 25-0765-00-C / 93366583 - \$305,440**

- 156kWdc/120kWac
- 24kWdc ground mount (exact layout is approximate and can be moved per district request)
- 132kWdc roof mount
- 1 x SolarEdge 120kWac inverter with DC optimizers
- Includes new chain link fence around ground mounted array, or appropriate guarding per city inspector
- 63% annual electrical offset



- **Elementary – 25-0633-00 / 97717264 - \$741,006**

- 430kWdc/330kWac
- Exact layout is approximate and can be moved per district request
- 3 x SolarEdge 110kWac inverters with DC optimizers
- 68% annual electrical offset



- **Middle School – 25-0710-01 / 10477406 - \$452,254**

- 260kWdc/200kWac
- Exact layout is approximate and can be moved per district request
- 4 x SolarEdge 50kWac inverters with DC optimizers
- 53% annual electrical offset



Materials detail:

- **1,302kWdc of solar modules (Primarily Heliene)**
 - 25-year performance warranty
 - 15-year product warranty
 - Module mix to include sufficient Domestic Content to justify the 10% bonus tax credit
- **986kWac of inverters (SolarEdge, Fronius or similar)**
 - 15-year extended warranty on the inverters
 - Inverter output circuit voltage to match building utilization voltage
 - Lifetime online monitoring utilizing customer's existing internet connection
- **Pitched ROOF Racking mounted flush with existing roof slope**
 - IronRidge XR rails
 - Integrated bonding
 - L-foot attachment points with S-5 standing seam clamps
 - Domestic content to justify the bonus 10% tax credit (direct pay)

- **Flat ROOF Racking mounted at a 10-degree nominal slope**
 - IronRidge BX racking
 - No roof penetrations for solar mounting
 - Designed to meet or exceed local code required wind loads
 - Domestic content to justify the bonus 10% tax credit (direct pay)
- **GROUND Racking mounted at a 20-degree nominal slope**
 - Preformed Line Products – PowerpeakAL racking
 - Galvanized steel sub structure
 - Integrated bonding
 - Designed to meet or exceed local code required wind and snow loads
 - Domestic Content to qualify for the base tax credit
- **Electrical**
 - New circuits from existing electrical services to inverter locations
 - DC wiring from inverter to solar array
 - Trenching, conduit, wire, sprinkler line repair & backfill included
 - King Solar will attempt to minimize damage, however, will not be responsible for repair to lawn or foliage due to trenching, backfill or equipment traffic
 - Wire sized appropriately to minimize voltage and production losses
 - All connections and terminations required
- **5 x Interconnection agreements with utility company**
- **10-year workmanship warranty on labor provided by King Solar**
- **All necessary permits and inspections included**

The above to be completed in a substantial and workman like manner according to standard industry practices, for the price of:

Two million three hundred ninety-five thousand seven hundred ninety-three dollars, less bonding if desired (\$2,395,793 - bonding) - 10% due upon notice to proceed and billed monthly based on completed scope. To the extent that any addition, alteration or deviation from the above scope of work increases King Solar's labor or materials cost, the additional scope will be submitted in writing to customer for approval and billed to customer at time additional scope is completed. King Solar will carry insurance appropriate for the scope of work, and customer will carry appropriate property-owner's insurance.

Pricing: The pricing shown above is good for 30 days and assumes installation in the 2027 calendar year.

Tariffs: King Solar has worked to secure inventory for your project that will not be affected by changes in tariffs as long as you commit in a timely manner. Should there be any unforeseen tariff changes King Solar will contact you immediately to discuss our recommendations which may include canceling the project.

6.5 Qualifications

King Solar has been selling, designing, installing, and maintaining solar energy projects since 1982. Obviously, the solar industry has evolved since the early years when solar thermal (a glorified greenhouse on your roof) was the best we had to offer. In the last 20 years King Solar has become a pillar in the solar industry throughout Kansas. In addition to being a full-service sales/design/installation/service company, King Solar's President, Mark Horst, has been integral in crafting and negotiating legislation to ensure stable utility solar policies for the future of your project and the solar industry in Kansas as a whole.

King Solar is dually licensed as a building and electrical contractor in most major jurisdictions throughout the state including Wichita/Sedgwick County (E9675, B8848) as well as Johnson County (2026-0010934). In addition to Kansas licensure, King Solar holds licenses in neighboring states including Missouri & Nebraska and many of our senior staff members also hold NABCEP certifications. One of King Solar's core values is *Stewardship: we use our resources for maximum impact*. As such, we have decided not to become licensed in the city of Chanute until such time we are awarded a project, but are adequately qualified to secure the necessary licensure should we be awarded this project.

In terms of insurance, please see our ACORD certificate attached as appendix O which verifies insurance coverage as required by this RFP. Additionally, it was requested that we provide detailed financial statements as part of this RFP. Because our response to this RFP becomes part of the public record we will decline to provide detailed financial statements, however, those can be provided as a confidential addendum upon request.

Similar project references:**USD 266 - Maize**

2 x locations with trusted long-term relationship beginning with Stan's home

- 237.6kWdc – Maize Career Academy – Ground mount - 2018
- 180.5kWdc – Pray woodman Elementary – 2023
- 6.8kWdc – Stan's house - 2016

All locations on-time and on-budget

Contact info:

Stanley Bergkamp
Maize Solar Foundation
sbergkamp@usd266.com
cell: 316-259-1653

USD 234 – Fort Scott School District

4 x sites (High School, Middle School, 2 x Elementary Schools)

- 405kWdc total project size
- Contracted through Trane Technologies
- 2023 – included on-going maintenance contract similar to this RFP

All locations on-time and on-budget

Contact info:

Nathan Compton
Contract Project Developer, Trane Technologies
Nathan.Compton@trane.com
Cell: 913-702-7812

Daniel Koppa
USD 234 Director of Facilities
daniel.koppa@usd234.org
Office: 620-233-0800

Peoples Bank & Trust

16 x locations spread throughout central Kansas

- 9.1kWdc – 50.6kWdc site sizes

2024 – current construction

All locations on-time and on-budget

- Current projects utilizing identical safe-harbor strategy as this RFP

Contact info:

John Houghton
CEO, Peoples Bank and Trust
jhoughton@peoples.bank
cell: 620-755-6471

King Solar's project team org chart:

President/core projects: Mark Horst, Master Electrician, NABCEP certified PVIP 101913-002307

- Due to this project scope, Mark will personally be handling the development of this project

Project managers:

- Jason Nisly, Journeyman Electrician, Master Plumber, Master Mechanical, NABCEP certified PVIP
- Philip Kauffman, Journeyman Electrician, NABCEP certified PVIP
- Shane Miller, awesome human

Licensed electricians:

- Mark Horst, Master
- Philip Kauffman, Journeyman
- Kelley LeDuc, Journeyman
- Spencer Nisly, Journeyman
- Jason Nisly, Journeyman

Licensed PE:

- Neil Satrom, PE (structural), Endeavor Engineering (Note: Neil is not an employee of King Solar)
- Dean Paul Levorsen, PE (electrical), Vector Engineering (Note: Dean is not an employee of King Solar)

DC leaders:

- Joshua Linden, roof mount specialty
- Davis Thomas, ground mount specialty

Subcontractors:

- King Solar is proud to do most solar specific labor in-house with King Solar employees. The exceptions to this for this RFP are:
 - o Professional Engineering: see "Licensed PE" above
 - o Boring (trenchless excavation, primarily for the HS-West location under the driveway): Keim's construction, Matthew Keim, Yoder KS
 - o Fencing: King Solar typically uses Yoder Fence, of Yoder KS, however due to the distance may elect to hire a local fencing contractor for ground mount fencing. This election does not limit King Solar's responsibility for fencing or appropriate guarding per city inspector.

Service department (O&M):

- Isaac Rankin, service manager
- Creyton Nisly, service dispatcher

Support staff:

- Makenzie Unruh – permitting, interconnection & general coordination
- Kendra Horst – Invoicing, compliance & insurance
- Taylor Nisly – Procurement, warehousing & mobilization
- Shane Miller – Scheduling & team morale
- Sam Bontrager – Equipment maintenance & delivery

Disclosures:

King Solar Inc. has not had any litigation, arbitration, or termination for cause, ever, including in the past five years.

APPENDIX A. Site Data

- Appendix A as provided in the original RFP dated 5-4-26 and as amended per Addendum No. 1 was used as the basis for site specific design.

APPENDIX B. Pricing Forms

- **B.1** – see Executive Summary on Page 1.
- **B.1.1 Ground mount options** – disregarded due to Addendum 1,
- **B.2 Required 10-year O&M option**
 - 10-year O&M (Years 1-10) available for a fixed fee of \$16/yr/kWdc payable at project completion: \$208,320 if purchased in conjunction with base proposal.
 - Description of services: See appendix N attached.
- **B.3 Production Guarantee Levels** (95% of estimated year 1 production)
 - **NOTE:** For the purpose of verifying actual weather data as required by Addendum 1 section 1.6, King Solar is including, at no additional cost to the district, a weather station with a calibrated irradiance sensor(s).
 - **HS-A HS Welding Shop**
 - Yr-1 guarantee: 135,220 kWh
 - Annual Degradation %: 0.5
 - 25-yr guarantee: 3,185,239 kWh
 - **HS-B HS West Feeder**
 - Yr-1 guarantee: 506,962 kWh
 - Annual Degradation %: 0.5
 - 25-yr guarantee: 11,941,968 kWh
 - **HS-C HS East Feeder**
 - Yr-1 guarantee: 216,287 kWh
 - Annual Degradation %: 0.5
 - 25-yr guarantee: 5,094,857 kWh
 - **Elementary**
 - Yr-1 guarantee: 605,592 kWh
 - Annual Degradation %: 0.5
 - 25-yr guarantee: 14,265,290 kWh
 - **Middle School**
 - Yr-1 guarantee: 348,791 kWh
 - Annual Degradation %: 0.5
 - 25-yr guarantee: 8,216,094 kWh

- **B.4 Allowances**

- We believe the TIC is accurate, however, in some situations there are unforeseen circumstances that require adjustments to the scope, and therefore price. The allowances for this RFP include, but are not limited to the following:
 - Sub-terranean obstructions impeding trenching, boring, or foundation installation
 - Electrical service upgrades required by the city/utility
 - Interconnection or utility engineering studies in excess of the standard interconnection application fees
 - Structural roof upgrades to accommodate the addition of solar panels
 - Weather events deviating from normal seasonal fluctuations in temperature or precipitation which affecting project timeline
 - Force Majeure
 - Unforeseen policy changes including retroactive tariffs

APPENDIX C. Required Certifications

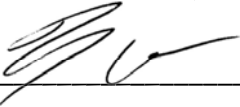
- C.1 – affirmed
- C.2 – certified
- C.3 – certified
- C.4 – certified
- C.5 – agreed
- C.6 – affirmed that none exist
- C.7 – affirmed
- C.8 – affirmed
- C.9 – certified
- C.10 – affirmed
- C.11 – Addenda Acknowledgements
 - Addendum #1 date: 5/18/2026, initials: MA
 - Addendum #2 date: 5/22/2026, initials: MA
- C.12 Authorized Signature
 - Firm: King Solar Inc.
 - Printed Name and Title: Mark Horst, President
 - Signature: 
 - Date: 5-26-26

APPENDIX D. Performance Guarantee form

- D.1 – Guaranteed Production (per Meter)
 - See Appendix B.3 above

- D.2 – Measurement
 - Annual production shall be measured via manufacturer provided metering and adjusted for force-majeure, curtailment, and snow or soiling per this section of the RFP.
 - To comply with RFP Addendum 1, section 1.6, King Solar includes (at no additional cost to the district) a weather station with calibrated irradiance sensor(s).

- D.3 – True-Up Payment
 - If necessary, payments shall be made per this section of the RFP.

- D.4 – Term and Security
 - King Solar shall per this section, as adjusted per addenda, provide financial statements, guarantees, surety, or letters of credit upon request.

Thank you for the opportunity to bid on this project, please don't hesitate to reach out with questions:

Mark Horst, President, King Solar Inc.

mark@kingsolar.net

office: 316-265-8568 ext. 9

cell: 316-300-6077



USD 413 authorized representative

Print name: _____

Signature: _____

Date: _____

Contact information: _____

APPENDIX E. Site Aerials

- Aerial images provided via Appendix E in the original RFP dated 5-4-26 and as amended per Addendum No. 1 were used as the basis for site specific design.

APPENDIX F. City of Chanute generator interconnection application

- King Solar acknowledges the requirement to facilitate the interconnection application(s) between the district and the City of Chanute utility. King Solar has included all necessary administrative labor to coordinate and provide necessary compliance documentation to the City. Per Appendix B.4 any Utility imposed fees above the standard (\$150 per meter) application fees are not included in this proposal. Should additional fees be required by the City, King Solar will provide written notice to the district and pass-thru these costs with no markup which will be billed as part of the next progress invoice.



KING SOLAR INC
 2615 SWITZER RD.
 HUTCHINSON, KS 67501
 PHONE: 316-265-8668
 LIC. No.: 08848

NEW PV SYSTEM
CHANUTE - USD 413
 VARIOUS ADDRESSES, CHANUTE,
 KS 66720

LINE DIAGRAM

DATE: 01.09.2026
 CAD DESIGN BY: V.G.
 NABCEP DESIGN: M.H.
 NABCEP REVIEW: J.N.
 REVISIONS

E-1

ID	TYPICAL	CONDUCTOR	CONDUIT	CURRENT-CARRYING CONDUCTORS IN CONDUIT	OCPD	EGC	TEMP. CORR. FACTOR	CONDUIT FILL FACTOR	CONT. CURRENT (125%)	BASE AMP.	DERATED AMP.	TERM. TEMP. RATING	AMP. @ TERMINAL
1	23	10 AWG PV WIRE, COPPER	FREE AIR	2	N/A	10 AWG PV WIRE, COPPER	0.91 (37.4 °C)	1	17.24A	55A	50.05A	75°C	50A
2	1	10 AWG PV WIRE, COPPER	2" DIA. EMT	16	N/A	10 AWG PV WIRE, COPPER	0.91 (37.4 °C)	0.5	17.24A	40A	18.2A	75°C	35A
2.1	2	10 AWG PV WIRE, COPPER	2" DIA. EMT	18 & 12	N/A	10 AWG PV WIRE, COPPER	0.91 (37.4 °C)	0.5	17.24A	40A	18.2A	75°C	35A
3	7	8 AWG THWN-2, COPPER	0.75" DIA. EMT	3-N	35A	6 AWG THWN-2, COPPER	0.91 (37.4 °C)	1	28.9A	55A	50.05A	75°C	50A
4	2	1/0 AWG THWN-2, COPPER	1.5" DIA. EMT	3-N	150A	6 AWG THWN-2, COPPER	0.91 (37.4 °C)	1	115.6A	170A	154.7A	75°C	150A

Appendix G.
 Page 17

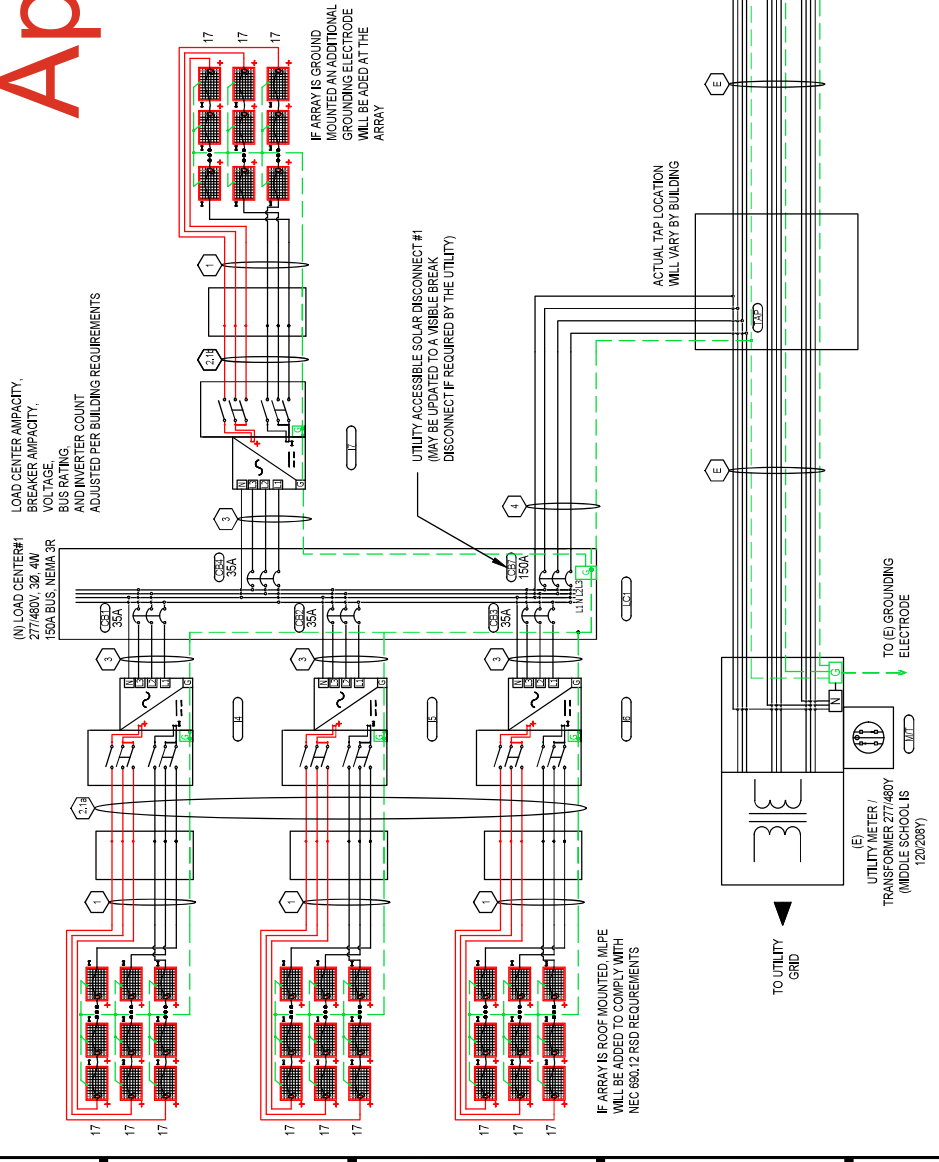

CONDUCTOR AND CONDUIT SCHEDULE W/ ELECTRICAL CALCULATIONS (THIS IS AN EXAMPLE, EACH BUILDING WILL BE SLIGHTLY DIFFERENT)

A B C D E F G H

A B C D E F G H



144HC M10 SL Bifacial Module

144 Half-Cut Monocrystalline 520W – 550W



21.3%

Utilizes the latest M10 size super high efficiency Monocrystalline PERC cells. Half cut design further reduces cell to module (CTM) losses.

Hail Resistance

3.2mm fully tempered frontside glass for superior hail resistance.

Anti-Reflective

Premium solar glass with anti reflective coating delivers more energy throughout the day

High Reliability

Proven resistance to PID and reliable in high temperature and humidity environments.

No Compromise Guarantee

15 Year Product Warranty
25 Year Linear Performance Guarantee

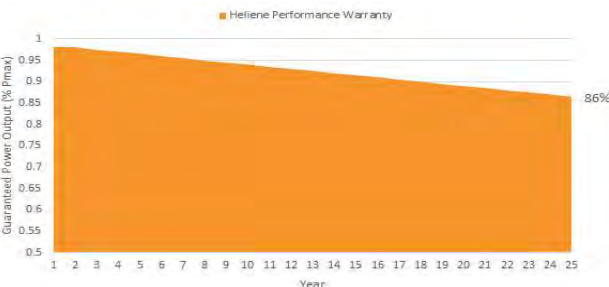

Manufactured Using International Quality System Standards: ISO9001

Half-Cut Design with Split Junction Box Technology

Bifacial Technology Enabling Additional Energy Harvest from Rear Side

2% First Year Degradation & 0.5% Annual Power Degradation

World-class Quality

- Heliene's fully automated manufacturing facilities with state-of-the-art robotics and computer aided inspection systems ensure the highest level of product quality and consistency
- All manufacturing locations are compliant with international quality standards and are ISO 9001 certified
- Heliene modules have received Top Performer rankings in several categories from PV Evolution Labs (PV EL) independent quality evaluations

Local Sales, Service, and Support

- With sales offices across the U.S. and Canada, Heliene prides itself on unsurpassed customer support for our clients. Heliene has become the brand of choice for many of the leading residential installers, developers and Independent Power Producers due to our innovative technology, product customization capability and just in time last-mile logistics support
- Local sales and customer support means answered phone calls and immediate answers to your technical and logistics questions. We understand your project schedules often change with little warning and endeavor to work with you to solve your project management challenges

Bankable Reputation

- Established in 2010, Heliene is recognized as highly bankable Tier 1 manufacturer of solar modules and has been approved for use by the U.S. Department of Defense, U.S. Army Corps of Engineers and from numerous top tier utility scale project debt providers
- By investing heavily in research and development, Heliene has been able to stay on the cutting edge of advances in module technology and manufacturing efficiency





Dimensions for 144HC M10 SL Bifacial Series Modules

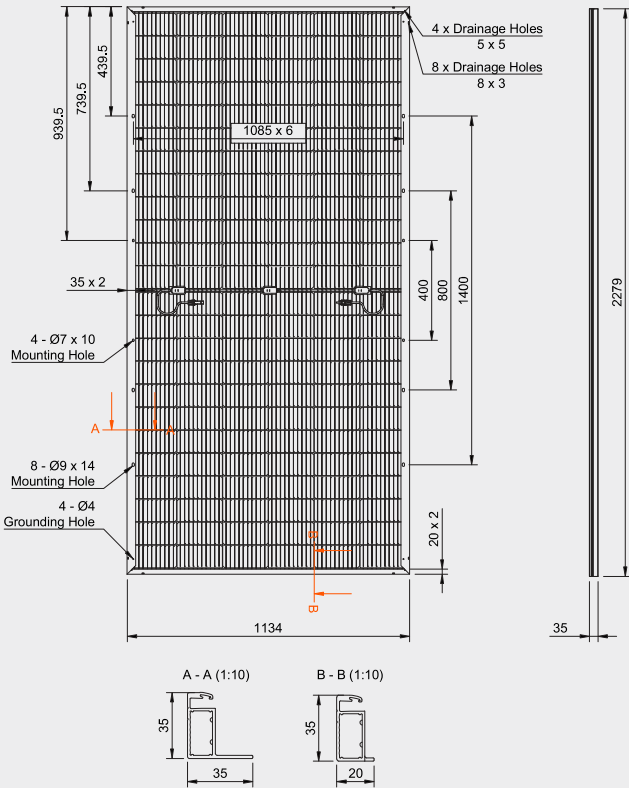

Electrical Data (STC)

Table with 9 columns: Parameter, Symbol, and 8 values. Parameters include Peak Rated Power*, Maximum Power Voltage, Maximum Power Current, Open Circuit Voltage*, Short Circuit Current**, Module Efficiency, Maximum Series Fuse Rating, Power Sorting Range, and Bifaciality Factor***.

STC - Standard Test Conditions: Irradiation 1000 W/m² - Air mass AM 1.5 - Cell temperature 25 °C,

*P_{mpp} Production Tolerance ± 3%, *V_{oc} Production Tolerance ± 3%, **I_{sc} Production Tolerance ± 4%

***Bifaciality Factor = P_{mpprear}/P_{mppfront} Where P_{mpprear} and P_{mppfront} are tested at STC

Electrical Data (NMOT)

Table with 9 columns: Parameter, Symbol, and 8 values. Parameters include Maximum Power, Maximum Power Voltage, Maximum Power Current, Open Circuit Voltage, and Short Circuit Current.

NMOT - Nominal Module Operating Temperature:

Irradiance at 800W/m2, Ambient Temperature 20°C, Wind speed 1m/s

Mechanical Data

Table with 2 columns: Component and Description. Components include Solar Cells, Module Construction, Dimensions, Weight, Frame, Glass, Junction Box, Output Cables, and Connectors.

I-V Curves for 144HC M10 SL Bifacial Series Modules

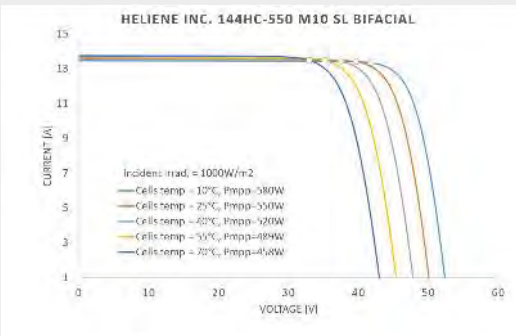
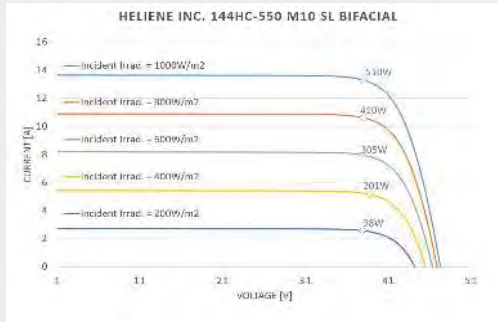

Certifications

UL Certification UL61215, UL61730, CSA C22.2 No. 61730

Temperature Ratings

Table with 2 columns: Parameter and Value. Parameters include Nominal Module Operating Temperature (NMOT), Temperature Coefficient of P_{max}, Temperature Coefficient of V_{oc}, and Temperature Coefficient of I_{sc}.

Maximum Ratings

Table with 2 columns: Parameter and Value. Parameters include Operational Temperature, Max System Voltage, Mech. Load Test (Front), Mech. Load Test (Back), and Fire Type.

Warranty

- 15 Year Product Warranty
25 Year Linear Power Guarantee

Packaging Configuration

Table with 2 columns: Configuration and Quantity. Configurations include Modules per Pallet 40' Container, Modules per 40' Container, Modules per Pallet 53' Trailer, and Modules per 53' trailer.



The Right Way™ to attach almost anything to metal roofs!

S-5![®]

The Right Way

S-5-H™ Clamp

The S-5-H clamp was specifically developed to securely and cost-effectively accommodate metal roof panels with a horizontal seam. The S-5-H is unique in that it allows for attachment to a horizontal seam on the vertical leg of the seam.

The clamp's two-piece design allows it to be installed anywhere along the length of the rib, making installation fast and easy! Just place the clamp on the seam, slide the insert piece into place, and tighten the setscrews. Go to www.S-5.com/tools for information about properly attaching S-5![®] clamps.

After the clamp is installed, affix ancillary items using the top stainless steel bolt provided. The S-5-H is perfect for use with S-5! ColorGard[®] snow retention system and other heavy-duty applications.

S-5-H Mini Clamp

The S-5-H Mini is a bit shorter than the S-5-H and has one setscrew rather than two. The mini is the choice for attaching all kinds of rooftop accessories: signs, walkways, satellite dishes, antennas, rooftop lighting, lightning protection systems, solar arrays, exhaust stack bracing, conduit, condensate lines, mechanical equipment—just about anything!*

*S-5! mini clamps are not compatible with, and should not be used with, S-5! SnoRail™/SnoFence™ or ColorGard[®] snow retention systems.



S-5-H and S-5-H Mini



The S-5-H clamp was specifically developed to accommodate standing seam panels with horizontal seams.

888-825-3432 | www.S-5.com

The strength of the S-5-H clamp is in its simple design. The patented setscrews will slightly dimple the metal seam material but will not puncture it—leaving roof manufacturers' warranties intact.

The **S-5-H and S-5-H Mini clamps** are each furnished with the hardware shown to the right. Each box also includes a bit tip for tightening setscrews using an electric screw gun. The structural aluminum attachment clamp is compatible with most common metal roofing materials excluding copper. All included hardware is stainless steel. Please visit www.S-5.com for more information including CAD details, metallurgical compatibilities, and specifications.

The S-5-H clamp has been tested for load-to-failure results on a variety of horizontal standing seam roof profiles from leading panel manufacturers. The independent lab test reports found on our website at www.S-5.com prove that S-5![®] holding strength is unmatched in the industry.

Example Profiles

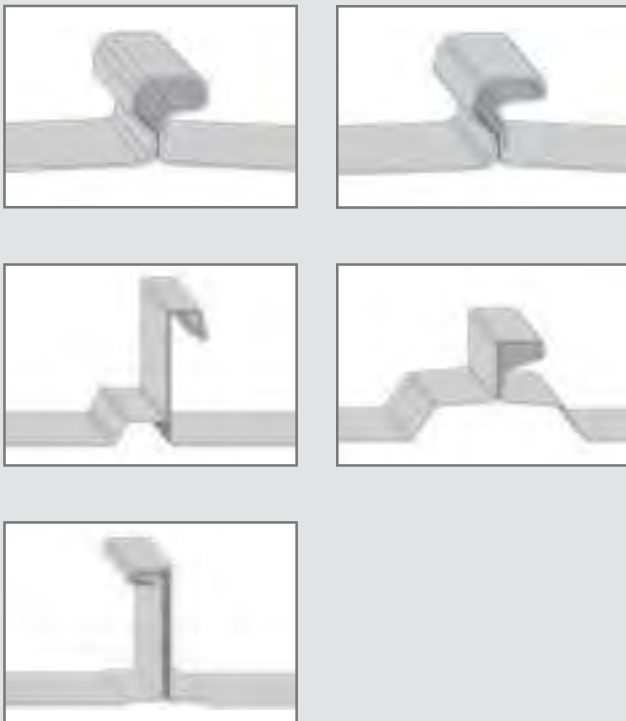

S-5-H[™]



S-5-H Mini

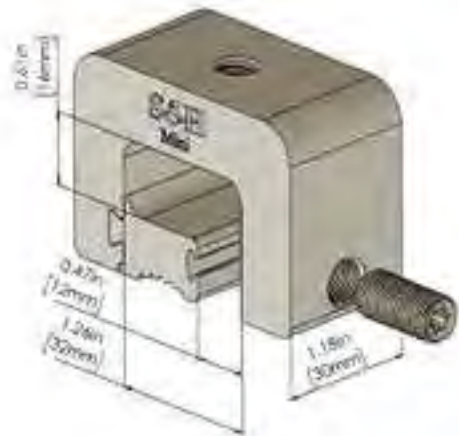

S-5![®] Warning! Please use this product responsibly!

Products are protected by multiple U.S. and foreign patents. Visit the website at www.S-5.com for complete information on patents and trademarks. Consult the S-5! website at www.S-5.com for published data regarding installation instructions and holding strength.

Copyright 2025, Metal Roof Innovations, Ltd. S-5! products are patent protected. S-5! aggressively protects its patents, trademarks, and copyrights. Version 102825.

Distributed by



FRONIUS SYMO ADVANCED

Powering three-phase projects that last -
now with integrated SunSpec PLC



PC board replacement concept



SnapInverter Technology



Integrated Data Communication



Smart Grid Ready



SuperFlex Design



Power Line Communication

Featuring ten models ranging from 10 kW to 24 kW, the Fronius Symo Advanced is the ideal inverter for commercial applications.

The new Advanced versions combine the benefits of the Fronius Symo with additional value for states with Module Level Shutdown requirements including integrated PLC transmitter for SunSpec Rapid Shutdown communication standard, compliance with NEC pre-2014, 2014 and 2017, zero tilt mounting, light weight and field serviceability.

TECHNICAL DATA FRONIUS SYMO ADVANCED (208-240 V VERSIONS)

INPUT DATA	SYMO 10.0-3 208-240		SYMO 12.0-3 208-240	
	208 V	240 V	208 V	240 V
Max. PV generator output ($P_{dc\ max}$)	15 kW _{peak}		18 kW _{peak}	
Max. input current ($I_{dc\ max1}$ / $I_{dc\ max2}$)			25 A / 16.5 A	
Max. array short circuit current (MPP1 / MPP2)			37.5 A / 24.8 A	
Nominal input voltage	350 V	370 V	350 V	370 V
DC input voltage range ($U_{dc\ min}$ + $U_{dc\ max}$)			200 - 600 V	
Feed-in start voltage ($U_{dc\ start}$)			200 V	
Usable MPP voltage range ($U_{mpp\ min}$ + $U_{mpp\ max}$)			300 - 500 V	
Max. input voltage			600 V	
Admissible conductor size DC	AWG 14-AWG 6 copper direct, AWG 6 aluminum direct, AWG 4-AWG 2 copper or aluminum with input combiner			
Number of MPP trackers	2			

OUTPUT DATA	SYMO 10.0-3 208-240		SYMO 12.0-3 208-240	
	208 V	240 V	208 V	240 V
AC nominal output (P_{acr})	9,995 W		11,995 W	
Max. output power	9,995 VA		11,995 VA	
Output configuration			208 / 240 V	
Frequency range (f_{min} - f_{max})			45 - 60 Hz	
Admissible conductor size AC	AWG 14 - AWG 6			
Total harmonic distortion	< 1.5 %		< 1.75 %	
Power factor ($\cos \phi_{acr}$)			0-1 ind. / cap.	
Max. continuous output current	27.7 A	24 A	33.3 A	28.9 A
OCPD/AC breaker size	35 A	30 A	45 A	40 A

EFFICIENCY	SYMO 10.0-3 208-240		SYMO 12.0-3 208-240	
	208 V	240 V	208 V	240 V
Max. Efficiency			97.0 %	
CEC Efficiency	96.5 %		96.5 %	

TECHNICAL DATA FRONIUS SYMO (208-240 V VERSIONS)

GENERAL DATA	SYMO 10.0-3 208-240	SYMO 12.0-3 208-240
Dimensions (height x width x depth)	510 x 725 x 225 mm (20.1 x 28.5 x 8.9 inches)	
Weight	41.7 kg (91.9 lbs)	
Protection Class	NEMA 4X	
Night time consumption	< 1 W	
Inverter topology	Transformerless	
Cooling	Regulated air cooling	
Installation	Indoor and outdoor installation, tilt from 0 - 90 degrees ¹	
DIN rail (length x width x depth)	max. 106 x 90 x 66 mm (max. 4.2 x 3.5 x 2.6 inches)	
Ambient operating temperature range	-40 - +60 °C (-40 - +140 °F)	
Permitted humidity	0 - 100 % (non-condensing)	
Elevation	max. input voltage of 600 V up to 3,400 m (11,155 ft)	
DC connection technology	6x DC+ and 6x DC- screw terminals for copper (solid / stranded / fine stranded) or aluminum (solid / stranded)	
AC connection technology	Screw terminals 14-6 AWG	
Certificates and compliance with standards	UL 1741-2010 Second Edition (incl. UL1741 Supplement SA 2016-09 for California Rule 21 and Hawaiian Electric Code Rule 14H), UL1998 (for functions: AFCI, RCMU and isolation monitoring), IEEE 1547-2003, IEEE 1547a-2014, IEEE 1547.1-2003, ANSI/IEEE C62.41, FCC Part 15 A & B, NEC 2017 Article 690, C22. 2 No. 107.1-16, UL1699B Issue 2 -2013, CSA TIL M-07 Issue 1 -2013	

¹ Fronius Shade Cover required for installation angles less than 15 degree

PROTECTIVE DEVICES	SYMO 10.0-3 208-240	SYMO 12.0-3 208-240
DC reverse polarity protection	Yes	
Anti islanding	Yes	
Over temperature protection	Output power derating /Active cooling	
AFCI	Yes	
Rapid shutdown compliant	Yes	
Ground Fault Protection with Isolation Monitor Interrupter	Yes	
DC disconnect	Yes	

INTERFACES	SYMO 10.0-3 208-240	SYMO 12.0-3 208-240
USB (A socket)	Datalogging and inverter update possible via USB	
2x RS422 (RJ45 socket)	Fronius Solar Net, interface protocol	
Power Line Communication (PLC)	Yes – SunSpec Rapid Shutdown communication standard	
Wi-Fi/Ethernet/Serial/ Datalogger and webservice ²	Wireless standard 802.11 b/g/n / Fronius Solar.web, SunSpec Modbus TCP, JSON / SunSpec Modbus RTU	
6 inputs and 4 digital I/Os ²	Load management; signaling, multipurpose I/O	

² Available with the Fronius Datamanager 2.0 Card (only one card required for up to 100 inverters)

TECHNICAL DATA FRONIUS SYMO (480 V VERSIONS)

INPUT DATA	SYMO 15.0-3 480	SYMO 20.0-3 480	SYMO 22.7-3 480	SYMO 24.0-3 480
Max. PV generator output ($P_{dc\ max}$)	22.5 kW _{peak}	30 kW _{peak}	34 kW _{peak}	36 kW _{peak}
Max. input current ($I_{dc\ max1}$ / $I_{dc\ max2}$)	33 A / 25 A			
Max. array short circuit current (MPP1 / MPP2)	49.5 A / 37.5 A			
Nominal input voltage	685 V	710 V	720 V	
DC input voltage range ($U_{dc\ min}$ + $U_{dc\ max}$)	200 - 1,000 V			
DC startup voltage	200 V			
Usable MPP voltage range ($U_{mpp\ min}$ + $U_{mpp\ max}$)	350 - 800 V	450 - 800 V	500 - 800 V	
Max. input voltage	1,000 V			
Admissible conductor size DC	AWG 14 - AWG 6 copper direct, AWG 6 aluminum direct, AWG 4 - AWG 2 copper or aluminum with input combiner			
Number of MPP trackers	2			

FRONIUS SYMO 24.0-3 480 CEC EFFICIENCY CURVE

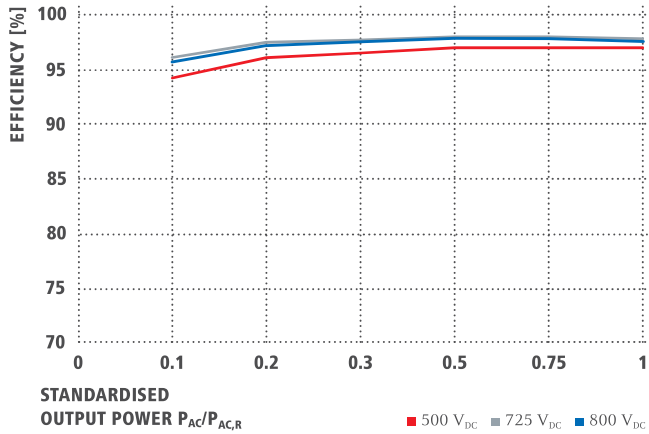

FRONIUS SYMO 24.0-3 480 TEMPERATURE DERATING CURVE

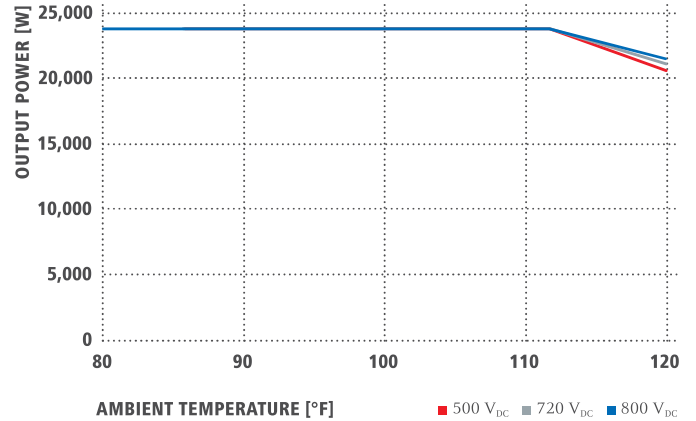

TECHNICAL DATA FRONIUS SYMO (480 V VERSIONS)

OUTPUT DATA	SYMO 15.0-3 480	SYMO 20.0-3 480	SYMO 22.7-3 480	SYMO 24.0-3 480
AC nominal Output ($P_{ac,r}$)	14,995 W	19,995 W	22,727 W	23,995 W
Max. output power	14,995 VA	19,995 VA	22,727 VA	23,995 VA
Grid connection	480 / 277 V WYE ³			
Frequency (frequency range $f_{min} - f_{max}$)	60 Hz (45 - 65 Hz)			
Admissible conductor size (AC)	AWG 14-AWG 6			
Total harmonic distortion	< 1.5 %	< 1 %	< 1.25 %	< 1 %
Power factor ($C_{os,ac,r}$)	0-1 ind. / cap.			
Max. continuous output current	18 A	24 A	27.3 A	28.9 A
OCBP/AC breaker size	25 A	30 A	35 A	40 A

EFFICIENCY	SYMO 15.0-3 480	SYMO 20.0-3 480	SYMO 22.7-3 480	SYMO 24.0-3 480
Max. Efficiency	98 %			
CEC Efficiency	97 %	97.5 %		

GENERAL DATA	SYMO 15.0-3 480	SYMO 20.0-3 480	SYMO 22.7-3 480	SYMO 24.0-3 480
Dimensions (height x width x depth)	510 x 725 x 225 mm (20.1 x 28.5 x 8.9 inches)			
Weight	43.4 kg (95.7 lbs)			
Protection Class	NEMA 4X			
Night time consumption	< 1 W			
Inverter topology	Transformerless			
Cooling	Regulated air cooling			
Installation	Indoor and outdoor installation, tilt from 0 - 90 degree ⁴			
DIN rail (length x width x depth)	max. 106 x 90 x 66 mm (max. 4.2 x 3.5 x 2.6 inches)			
Ambient operating temperature range	-40 - +60 °C (-40°F - + 140 °F)			
Permitted humidity	0 - 100 % (non-condensing)			
Elevation	2000 m (6562 ft) with a max. input voltage of 1000 V / 3400 m (11155 ft) with a max. input voltage of 850 V			
DC connection technology	6x DC+ and 6x DC- screw terminals for copper (solid / stranded / fine stranded) or aluminum (solid / stranded)			
AC connection technology	Screw terminals 14-6 AWG			
Certificates and compliance with standards	UL 1741-2010 Second Edition (incl. UL1741 Supplement SA 2016-09 for California Rule 21 and Hawaiian Electric Code Rule 14H), UL1998 (for functions: AFCI, RCMU and isolation monitoring), IEEE 1547-2003, IEEE 1547a-2014, IEEE 1547.1-2003, ANSI/IEEE C62.41, FCC Part 15 A & B, NEC 2017 Article 690, C22. 2 No. 107.1-16, UL1699B Issue 2 -2013, CSA TIL M-07 Issue 1 -2013			

³ +N for sensing purposes - no current carrying conductor

⁴ Fronius Shade Cover required for installation angles less than 15 degree

PROTECTIVE DEVICES	SYMO 15.0-3 480	SYMO 20.0-3 480	SYMO 22.7-3 480	SYMO 24.0-3 480
DC reverse polarity protection			Yes	
Anti islanding			Yes	
Over temperature protection		Output power derating / Active cooling		
AFCI			Yes	
Rapid shutdown compliant			Yes	
Ground Fault Protection with Isolation Monitor Interrupter			Yes	
DC disconnect			Yes	

INTERFACES	SYMO 15.0-3 480	SYMO 20.0-3 480	SYMO 22.7-3 480	SYMO 24.0-3 480
USB (A socket)		Datalogging and inverter update possible via USB		
2x RS422 (RJ45 socket)		Fronius Solar Net, interface protocol		
Power Line Communication (PLC)		Yes – SunSpec Rapid Shutdown communication standard		
Wi-Fi/Ethernet/Serial/ Datalogger and webservice ²		Wireless standard 802.11 b/g/n / Fronius Solar.web, SunSpec Modbus TCP, JSON / SunSpec Modbus RTU		
6 inputs and 4 digital I/Os ²		Load management; signaling, multipurpose I/O		

² Available with the Fronius Datamanager 2.0 Card (only one card required for up to 100 inverters)

/ Perfect Welding / Solar Energy / Perfect Charging

THREE BUSINESS UNITS, ONE GOAL: TO SET THE STANDARD THROUGH TECHNOLOGICAL ADVANCEMENT.

What began in 1945 as a one-man operation now sets technological standards in the fields of welding technology, photovoltaics and battery charging. Today, the company has around 4,760 employees worldwide and 1,253 patents for product development show the innovative spirit within the company. Sustainable development means for us to implement environmentally relevant and social aspects equally with economic factors. Our goal has remained constant throughout: to be the innovation leader.

Further information about all Fronius products and our global sales partners and representatives can be found at www.fronius.com



Fronius USA LLC
6797 Fronius Drive
Portage, IN 46368
USA
pv-support-usa@fronius.com
www.fronius.us/pv

Fronius International GmbH
Froniusplatz 1
4600 Wels
Austria
pv-sales@fronius.com
www.fronius.com

Three Phase Inverter with Synergy Technology

For the 277/480V Grid for North America

SE80KUS / SE100KUS / SE110KUS / SE120KUS

INVERTER



Powered by unique pre-commissioning process for rapid system installation

- Pre-commissioning feature for automated validation of system components and wiring during the site installation process and prior to grid connection
- Easy 2-person installation with lightweight, modular design (each inverter consists of 2 or 3 Synergy units and 1 Synergy Manager)
- Independent operation of each Synergy unit enables higher uptime and easy serviceability
- Built-in thermal sensors detect faulty wiring, ensuring enhanced protection and safety
- Built-in arc fault protection and rapid shutdown
- Built-in PID mitigation for maximized system performance
- Monitored* and field-replaceable surge protection devices, to better withstand surges caused by lightning or other events
- Built-in module-level monitoring with Ethernet or cellular communication for full system visibility

*Applicable only for DC and AC SPDs

/ Three Phase Inverter with Synergy Technology

For the 277/480V Grid for North America

SE80KUS / SE100KUS / SE110KUS / SE120KUS

MODEL NUMBER	SE80KUS	SE100KUS	SE110KUS	SE120KUS	
APPLICABLE TO INVERTERS WITH PART NUMBER	SExxK-USx8lxxxx				UNITS
OUTPUT					
Rated AC Active Output Power	80000	100000	110000	120000	W
Maximum AC Apparent Output Power	80000	100000	120000	120000	VA
AC Output Line Connections	3W + PE, 4W + PE				
Supported Grids	WYE: TN-C, TN-S, TN-C-S, TT, IT; Delta: IT				
AC Output Voltage Minimum-Nominal-Maximum ⁽¹⁾ (L-N)	244 – 277 – 305				Vac
AC Output Voltage Minimum-Nominal-Maximum ⁽¹⁾ (L-L)	422.5 – 480 – 529				Vac
AC Frequency Min-Nom-Max ⁽¹⁾	59.5 – 60 – 60.5				Hz
Maximum Continuous Output Current (per Phase, PF=1)	96.5	120	144.3		Aac
GFDI Threshold	1				A
Utility Monitoring, Islanding Protection, Configurable Power Factor, Country Configurable Thresholds	Yes				
Total Harmonic Distortion	≤ 3				%
Power Factor Range	±0.85 to 1				
INPUT					
Maximum DC Power (Module STC) Inverter / Synergy Unit	140000 / 70000	175000 / 58300	210000 / 70000		W
Transformer-less, Ungrounded	Yes				
Maximum Input Voltage DC+ to DC-	1000				Vdc
Operating Voltage Range	850 – 1000				Vdc
Maximum Input Current	2 x 48.25	3 x 40	3 x 48.25		Adc
Reverse-Polarity Protection	Yes				
Ground-Fault Isolation Detection	167kΩ sensitivity per Synergy Unit ⁽²⁾				
CEC Weighted Efficiency	98.5				%
Nighttime Power Consumption	< 8	< 12			W
ADDITIONAL FEATURES					
Supported Communication Interfaces ⁽³⁾	2 x RS485, Ethernet, Wi-Fi (optional), Cellular (optional)				
Smart Energy Management	Export Limitation				
Inverter Commissioning	With the SetApp mobile application using built-in Wi-Fi access point for local connection				
Arc Fault Protection	Built-in, User Configurable (According to UL1699B)				
Photovoltaic Rapid Shutdown System	NEC 2014 – 2023, built-in				
PID Rectifier	Nighttime, built-in				
RS485 Surge Protection (ports 1+2)	Type II, field replaceable, integrated				
AC, DC Surge Protection	Type II, field replaceable, integrated				
DC Fuses (Single Pole)	25A, integrated				
VAR at Night ⁽⁴⁾	Yes				
DC SAFETY SWITCH					
DC Disconnect	Built-in				
STANDARD COMPLIANCE					
Safety	UL1699B, UL1741, UL1741 SA, UL1741 SB, UL1998, CSA C22.2#107.1, Canadian AFCI according to T.I.L. M-07				
Grid Connection Standards	IEEE 1547-2018, Rule 21, Rule 14 (HI)				
Emissions	FCC part 15 class A				
Advanced Grid Support Capabilities	L/HVRT; L/HVRT; VOLT-VAR; VOLT-Watt; Frequency-Watt; Ramp Rate Control; Fixed Power Factor; Fixed Q; Cos (Phi) / Watt				

(1) For other regional settings please contact SolarEdge support.

(2) Where permitted by local regulations.

(3) For specifications of the optional communication options, visit the [Communication product page](#) or the [Knowledge Center](#) to download the relevant product datasheet.

(4) For details, see [Set Volt Ampere Reactive at Night](#).

/ Three Phase Inverter with Synergy Technology

For the 277/480V Grid for North America

SE80KUS / SE100KUS / SE110KUS / SE120KUS

MODEL NUMBER		SE80KUS	SE100KUS	SE110KUS	SE120KUS	
APPLICABLE TO INVERTERS WITH PART NUMBER		SExxK-USx8lxxxx				UNITS
INSTALLATION SPECIFICATIONS						
Number of Synergy Units per Inverter		2		3		
Ac Max Conduit Size		2 ½"				in
Max AWG Line / PE		4/0 / 1/0				
DC Max Conduit Size		1 x 3"; 2 x 2"				in
DC Input Inverter/ Synergy Unit	Multi-input (SExxK-USxxxxZ4)	8 / 4 pairs; 6-12 AWG		12 / 4 pairs; 6-12 AWG		
	Combined input (SExxK-USxxxxW4)	2 pairs / 1 pair, Max 2 AWG; copper or aluminum		3 pairs / 1 pair, Max 2 AWG; copper or aluminum		
Dimensions (H x W x D)		Synergy Unit: 22 x 12.9 x 10.75 / 558 x 328 x 273 Synergy Manager: 14.17 x 22.4 x 11.6 / 360 x 560 x 295				in / mm
Weight		Synergy Unit: 70.4 / 32 Synergy Manager: 39.6 / 18				lb / kg
Operating Temperature Range		-40 to +140 / -40 to +60 ⁽⁴⁾				°F / °C
Cooling		Fan (user replaceable)				
Noise		< 67				dBA
Protection Rating		NEMA 3R				
Mounting		Brackets provided				

(5) For power de-rating information refer to the [Temperature Derating Technical Note for North America](#).

SolarEdge is a global leader in smart energy technology. By leveraging world-class engineering capabilities and with a relentless focus on innovation, SolarEdge creates smart energy solutions that power our lives and drive future progress.

SolarEdge developed an intelligent inverter solution that changed the way power is harvested and managed in photovoltaic (PV) systems. The SolarEdge DC optimized inverter maximizes power generation while lowering the cost of energy produced by the PV system.

Continuing to advance smart energy, SolarEdge addresses a broad range of energy market segments through its PV, storage, EV charging, UPS, and grid services solutions.

 SolarEdge

 @SolarEdgePV

 @SolarEdgePV

 SolarEdgePV

 SolarEdge

 www.solaredge.com/corporate/contact

solaredge.com

© SolarEdge Technologies, Ltd. All rights reserved. SOLAREEDGE, the SolarEdge logo, OPTIMIZED BY SOLAREEDGE are trademarks or registered trademarks of SolarEdge Technologies, Inc. All other trademarks mentioned herein are trademarks of their respective owners. Datasheet: DS-000020-NAM. Date: November 27, 2025. Subject to change without notice.

Cautionary Note Regarding Market Data and Industry Forecasts: This brochure may contain market data and industry forecasts from certain third-party sources. This information is based on industry surveys and the preparer's expertise in the industry and there can be no assurance that any such market data is accurate or that any such industry forecasts will be achieved. Although we have not independently verified the accuracy of such market data and industry forecasts, we believe that the market data is reliable and that the industry forecasts are reasonable.



solaredge



POWER PEAK™ AL

Aluminum Large Scale
Ground Mount System



-  COMMUNICATIONS
-  ENERGY
-  SPECIAL INDUSTRIES
-  SOLAR



The POWER PEAK™ AL – PV Solar Mounting System

The **POWER PEAK™ AL** PV mounting system is designed for larger scale ground mount installations that require faster build rates. Combining high strength steel attachment components, lightweight module rails and the patented Lock-in-Place RAD™ clamp, the POWER PEAK provides a fast and secure mounting structure for most PV modules.

POWER PEAK mounting structures are optimized to site-specific conditions and assemble over pile driven galvanized “I” beams. Component attachments feature built-in field adjustments for post misalignment and include captive bolts. The single row, vertical post design greatly reduces the number of ground penetrations while providing increased ground clearance options.

The POWER PEAK mounting system assembles without any lifting equipment or machinery and pre-assembled components significantly reduce installation time and labor. Structures are specified and manufactured to match module string counts to reduce wiring time and materials. The unique module rails feature built in wire channels for a professional appearance.

Technical Services Offered

- Permit ready drawings
- Quick turnaround on proposals
- Foundation designs
- Pile driving proposals
- Rack assembly proposals

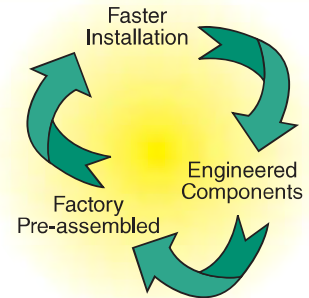

Key Benefits

- **Site Optimized Designs**
Reduces overall material costs
- **Factory Pre-assembled Components**
Eliminates field measurements and handling of small hardware
- **String Size Matched Sub-arrays**
Faster repetitive layouts, easier wiring
- **Local Pre-drilled I-Beam Vertical Posts**
Eliminates on-site fabrication and reduces freight costs
- **Racking Adjustments**
Easier to square the structure when posts twist or misalign
- **Lightweight Components**
Eliminates heavy-duty lifting equipment and promotes “assembly-line” installation
- **Integral Wire Management**
Reduces labor, meets code and provides a clean and professional appearance
- **Module Clamp Assemblies**
Faster installation with a ¼" turn and no loose parts

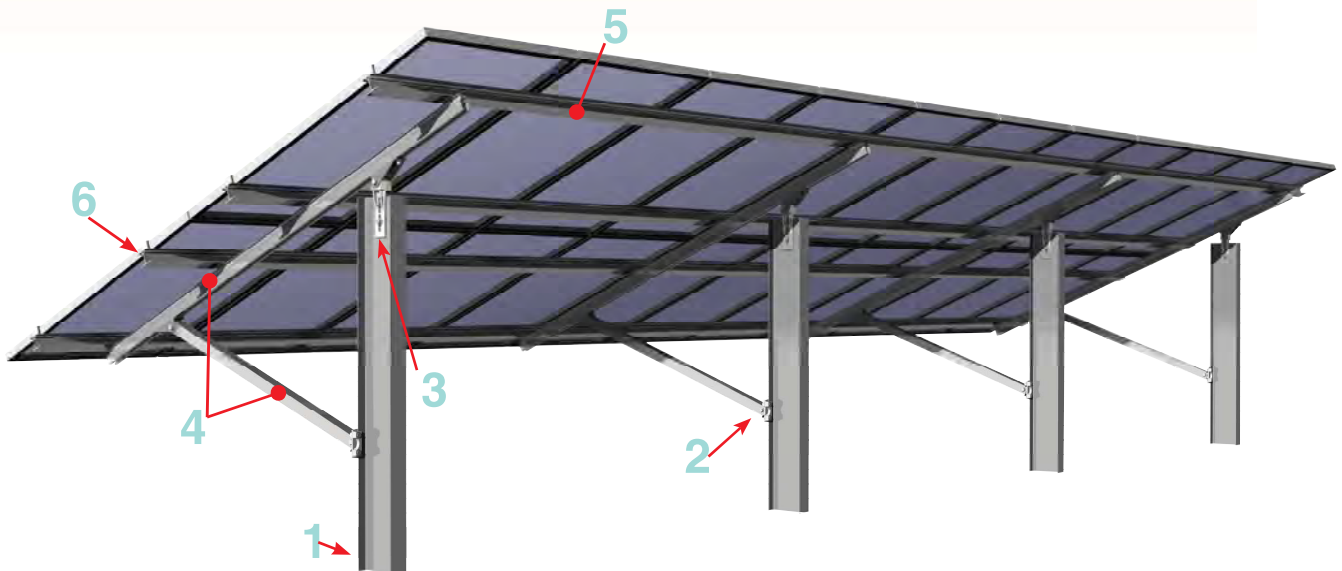

Performance and Simplicity Connect

1 Standard I Beams

- Pile Driven with standard equipment
- Sized per site conditions to reduce overall system costs
- Sourced locally to reduce freight costs and delivery times
- Predrilled and galvanized - **Ready to install**



2 Strut Attachment

- Field adjustable
- Captive bolts – **No loose parts**
- Hot dip galvanized corrosion protection
- Lateral adjustments resolve twisted posts



3 Strongback Attachments

- Vertical field adjustments (2.5 inches)
- Hot dip galvanized **corrosion protection**
- Built-in articulation for twisted posts (± 5 degrees)
- High strength steel



4 Strongback Assembly

- Unfold and hang for easy assembly to posts
- Factory pre-assembled – strong back / strut / rail brackets
- **Field adjustable for easy alignment**
- Lightweight, High Strength Aluminum



5 Module Rails

- Lightweight, High Strength Aluminum
- **Built-in Wire channels**
- Lift into place
- Long lengths minimize splices



6 Module Clamps

- Pre-install clamps in rail then slide module in place.
- Heavy-duty stainless steel
- Factory pre-assembled – Lock-in-Place **RAD™ clamp**
- Built-in electrical grounding option
- Secure module clamping



Pre-Assembled Components of POWER PEAK™ AL

Each POWER PEAK system ships with factory pre-assembled components, resulting in reduced installation time and costs. Preset components not only avoid loose parts on-site but also eliminate measuring and simplify the installation.



End Clamp Assembly

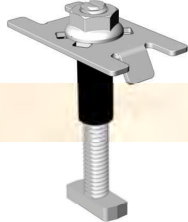

Mid Clamp Assembly



Strongback Assembly



Strut Attachment Assembly

The POWER PEAK AL is the newest member of PLP's field-proven ground mount solutions including:

Multi-Pole Mounts (MPM-G2)

Large Ground Mounts (LGM)

PLP's engineering staff is available to assist with your next project. Please visit www.preformed.com and complete an RFQ Form or contact our product support team at (800) 260-3792.



PREFORMED
LINE PRODUCTS

Global Headquarters
660 Beta Drive
Cleveland, Ohio 44143 USA
Telephone: 440.461.5200
Fax: 440.442.8816
Website: preformed.com
Email: info@plpsolar.com

© 2017 Preformed Line Products
Printed in U.S.A.
SL-SS-1109-6
06.17IH



Strong, Light, and Ready for Anything

The IronRidge BX System is designed to meet the needs of commercial solar—navigating complex roof layouts, while also handling the most extreme environmental conditions.

At the core of BX is the Chassis, a ballasted mount made of BASF Ultramid polyamides. They are exceptional for their high mechanical strength, rigidity and thermal stability (also being 100% recyclable).

Moreover, Ultramid polyamides afford good impact resistance even at low temperatures as well as UV protections for long life. Chassis come in 5° and 10° options and are backed by IronRidge's 25-year warranty.

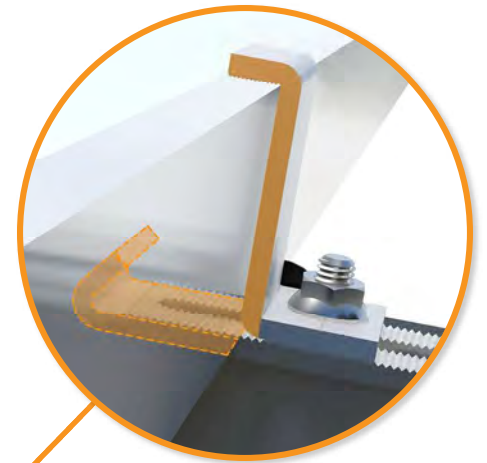

Top & Bottom Clamp

The multi-directional grip on the module from above and below ensures a strong connection regardless of force direction.



360° Reinforcement

A flange around the entire perimeter helps to reinforce and stiffen the Chassis in all directions—alongside wide bends to reduce point loading and braced corners to increase rigidity.

Roof-Friendly Design

Wide base spreads weight and reduces point pressure, while openings along the bottom and corners prevent pooling and reduce ballast weathering.



Inter-Row Spacing & Edge Clearances

5° Chassis



10° Chassis



With 10-13" inter-row spacing, BX provides an **8-10% increase** in power density compared with other ballasted systems—that's a **capacity increase of 20%** in a typical 50kW system. The BX Chassis geometry also offers more than 5" of clearance in the 10-degree configuration and 8" in the 5-degree configuration, enabling the system to avoid drain domes, roof saddles, and conduit supports.

Flat Roof Attachment Anchors

BX Systems can be fully ballasted, fully anchored, or a hybrid optimized for the site.

Combine BX with an IronRidge Flat Roof Attachment Kit to eliminate hundreds of pounds of required ballast weight and achieve configurations as light as 3 PSF.

The placement and fastening method can be optimized for existing roof structures, and pre-approved membranes are offered to maintain membrane roof warranties.



Testing & Certification

Design Assistant

Automated design software provides an accurate bill of materials, using a simple drag-and-draw interface to generate a complete system plan—also generate a ballast map showing the required ballast for each Chassis.

Permit Documentation

Design Assistant project reports are backed with a ASCE/PE stamp and Commercial Services are also available to assist with more complex projects. Visit our website or contact an IronRidge sales representative.

UL 2703 & 3741 Listed

BX conforms to the latest UL safety standards for PV systems, including mechanical, bonding, hazard control, and Class A Fire Ratings (without wind deflectors). Ninety percent of solar modules are fully supported.



Solar Is Not Always Sunny

Over their lifetime, solar panels experience countless extreme weather events. Not just the worst storms in years, but the worst storms in 40 years. High winds capable of ripping panels from a roof, and snowfalls weighing enough to buckle a panel frame.

XR Rails are the structural backbone preventing these results. They resist uplift, protect against buckling and safely and efficiently transfer loads into the building structure. Their superior spanning capability requires fewer roof attachments, reducing the number of roof penetrations and the amount of installation time.

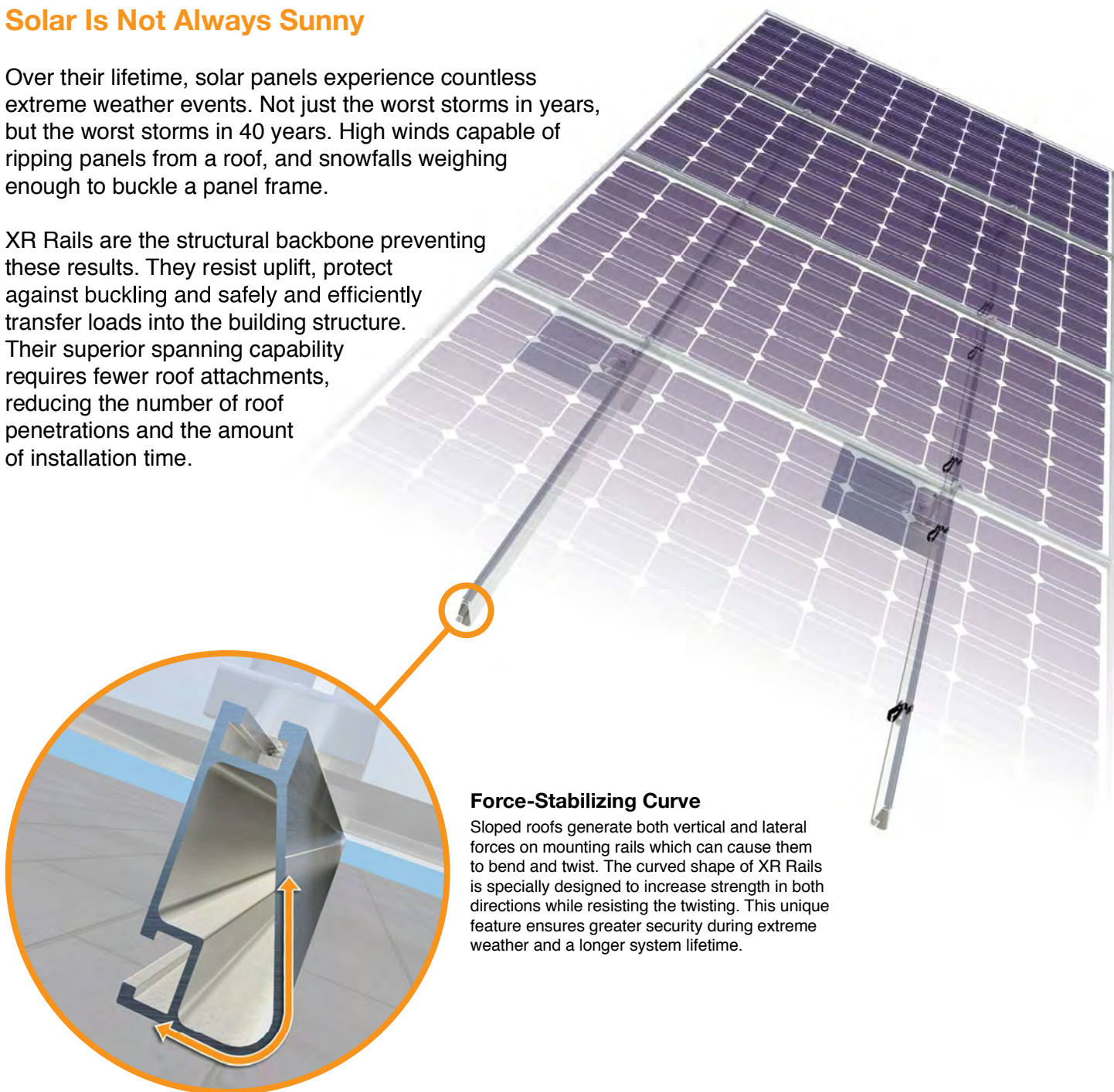

Force-Stabilizing Curve

Sloped roofs generate both vertical and lateral forces on mounting rails which can cause them to bend and twist. The curved shape of XR Rails is specially designed to increase strength in both directions while resisting the twisting. This unique feature ensures greater security during extreme weather and a longer system lifetime.

Compatible with Flat & Pitched Roofs



XR Rails are compatible with FlashFoot and other pitched roof attachments.



IronRidge offers a range of tilt leg options for flat roof mounting applications.

Corrosion-Resistant Materials

All XR Rails are made of marine-grade aluminum alloy, then protected with an anodized finish. Anodizing prevents surface and structural corrosion, while also providing a more attractive appearance.



XR Rail Family

The XR Rail Family offers the strength of a curved rail in three targeted sizes. Each size supports specific design loads, while minimizing material costs. Depending on your location, there is an XR Rail to match.



XR10

XR10 is a sleek, low-profile mounting rail, designed for regions with light or no snow. It achieves 6 foot spans, while remaining light and economical.

- 6' spanning capability
- Moderate load capability
- Clear anodized finish
- Internal splices available



XR100

XR100 is the ultimate residential mounting rail. It supports a range of wind and snow conditions, while also maximizing spans up to 8 feet.

- 8' spanning capability
- Heavy load capability
- Clear & black anodized finish
- Internal splices available



XR1000

XR1000 is a heavyweight among solar mounting rails. It's built to handle extreme climates and spans 12 feet or more for commercial applications.

- 12' spanning capability
- Extreme load capability
- Clear anodized finish
- Internal splices available

Rail Selection

The following table was prepared in compliance with applicable engineering codes and standards. Values are based on the following criteria: ASCE 7-10, Roof Zone 1, Exposure B, Roof Slope of 7 to 27 degrees and Mean Building Height of 30 ft. Visit IronRidge.com for detailed span tables and certifications.

Load		Rail Span					
Snow (PSF)	Wind (MPH)	4'	5' 4"	6'	8'	10'	12'
None	100	XR10		XR100		XR1000	
	120						
	140						
	160						
10-20	100					XR1000	
	120						
	140						
	160						
30	100						
	160						
40	100						
	160						
50-70	160						
80-90	160						

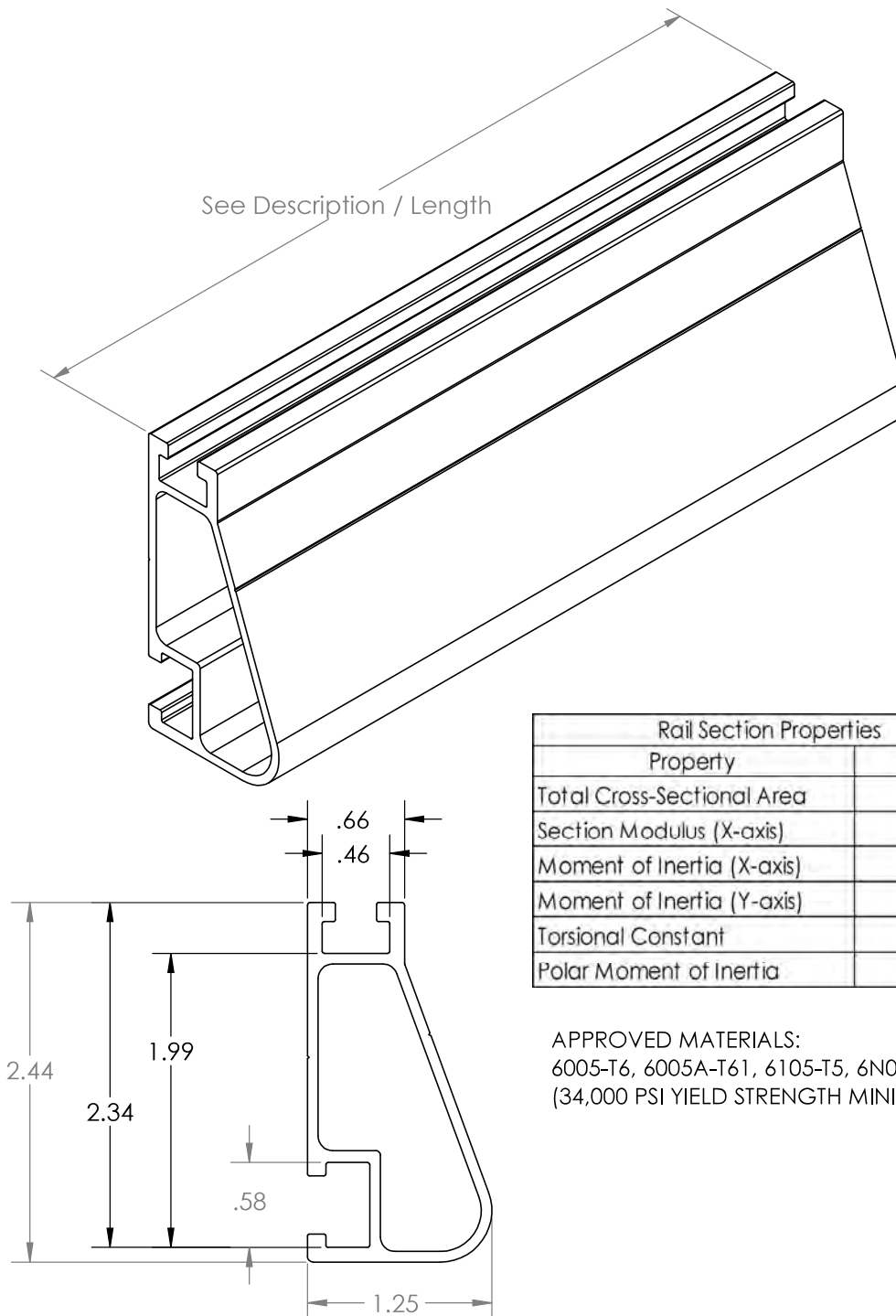

Rail Section Properties	
Property	Value
Total Cross-Sectional Area	0.582 in ²
Section Modulus (X-axis)	0.297 in ³
Moment of Inertia (X-axis)	0.390 in ⁴
Moment of Inertia (Y-axis)	0.085 in ⁴
Torsional Constant	0.214 in ³
Polar Moment of Inertia	0.126 in ⁴

APPROVED MATERIALS:
 6005-T6, 6005A-T61, 6105-T5, 6N01-T6
 (34,000 PSI YIELD STRENGTH MINIMUM)

Clear Part Number	Black Part Number	Description / Length	Material	Weight
XR-100-132A	XR-100-132B	XR100, Rail 132" (11 Feet)	6000-Series Aluminum	7.50 lbs.
XR-100-168A	XR-100-168B	XR100, Rail 168" (14 Feet)		9.55 lbs.
XR-100-204A	XR-100-204B	XR100, Rail 204" (17 Feet)		11.60 lbs.



Appendix I.





Appendix J. - page 42

Calibrated down (bearing) pressure test



Calibrated up (extraction) pressure test:



Calibrated lateral bearing test setup:



Dynamometer readout (5 pound):





Appendix K.

page 43

Production comparison in kilowatt hours (KWH)

HS - Weld shop - 25-0765-00-A

Month	Historic Usage	96kWdc/72kWac		
		Solar Production	Net	Percent
Jan	11320	9,657	1663	85%
Feb	12640	8,858	3782	70%
Mar	12160	12,317	157	100%
Apr	15880	12,486	3394	79%
May	18400	14,329	4071	78%
Jun	19440	14,418	5022	74%
Jul	11520	15,561	4041	100%
Aug	17080	14,307	2773	84%
Sep	12560	12,638	78	100%
Oct	24800	10,872	13928	44%
Nov	11000	8,848	2152	80%
Dec	10720	8,046	2674	75%
Total	177520	142337	39459	80%

The "usage" column shows your historic usage for the past year.

The "Solar" column shows the expected production of the system based on historic weather data, roof orientation & angle.

The "Net" column represents your monthly usage after you install solar which shows your usage less the solar production giving you the "Net" consumption from the grid.

When your "Net" consumption is negative it is shown in red. This means in that month that you produced more electricity than you used resulting in over production. Over production isn't necessarily bad, but we typically recommend sizing systems for minimal over production.

The "Percent" column represents how much of your expected net usage is offset by solar. So for any given month you can see that your expected usage will be ___% "solar powered". However, this is not the expected percent of utility bill savings, that will vary depending on your utility's rate structure.



Production comparison in kilowatt hours (KWH)

HS - West feeder - 25-0765-00-B

Month	Historic Usage	360kWdc/264kWac		
		Solar Production	Net	Percent
Jan	59100	36,206	22894	61%
Feb	58500	33,205	25295	57%
Mar	60600	46,187	14413	76%
Apr	79800	46,821	32979	59%
May	57900	53,733	4167	93%
Jun	86700	54,066	32634	62%
Jul	104100	58,351	45749	56%
Aug	111900	53,648	58252	48%
Sep	94500	47,391	47109	50%
Oct	81600	40,765	40835	50%
Nov	61500	33,167	28333	54%
Dec	56100	30,104	25996	54%
Total	912300	533644	378656	58%

The "usage" column shows your historic usage for the past year.

The "Solar" column shows the expected production of the system based on historic weather data, roof orientation & angle.

The "Net" column represents your monthly usage after you install solar which shows your usage less the solar production giving you the "Net" consumption from the grid.

When your "Net" consumption is negative it is shown in **red**. This means in that month that you produced more electricity than you used resulting in over production. Over production isn't necessarily bad, but we typically recommend sizing systems for minimal over production.

The "Percent" column represents how much of your expected net usage is offset by solar. So for any given month you can see that your expected usage will be ___% "solar powered". However, this is not the expected percent of utility bill savings, that will vary depending on your utility's rate structure.



Production comparison in kilowatt hours (KWH)

HS - East feeder - 25-0765-00-C

Month	Historic Usage	156kWdc/120kWac		
		Solar Production	Net	Percent
Jan	18800	14,701	4099	78%
Feb	18600	13,901	4699	75%
Mar	19600	19,848	248	100%
Apr	27200	20,416	6784	75%
May	29800	23,588	6212	79%
Jun	48800	23,753	25047	49%
Jul	52600	25,461	27139	48%
Aug	48600	23,134	25466	48%
Sep	38400	20,146	18254	52%
Oct	24800	16,954	7846	68%
Nov	17600	13,564	4036	77%
Dec	17800	12,205	5595	69%
Total	362600	227671	135177	63%

The "usage" column shows your historic usage for the past year.

The "Solar" column shows the expected production of the system based on historic weather data, roof orientation & angle.

The "Net" column represents your monthly usage after you install solar which shows your usage less the solar production giving you the "Net" consumption from the grid.

When your "Net" consumption is negative it is shown in **red**. This means in that month that you produced more electricity than you used resulting in over production. Over production isn't necessarily bad, but we typically recommend sizing systems for minimal over production.

The "Percent" column represents how much of your expected net usage is offset by solar. So for any given month you can see that your expected usage will be ___% "solar powered". However, this is not the expected percent of utility bill savings, that will vary depending on your utility's rate structure.



Production comparison in kilowatt hours (KWH)

Elementary - 25-0633-00

Month	Historic Usage	430kWdc/330kWac		
		Solar Production	Net	Percent
Jan	63900	38,783	25117	61%
Feb	59400	37,714	21686	63%
Mar	54300	55,522	1222	100%
Apr	72900	58,215	14685	80%
May	72600	68,123	4477	94%
Jun	111600	68,954	42646	62%
Jul	110700	73,550	37150	66%
Aug	109800	65,982	43818	60%
Sep	92700	56,314	36386	61%
Oct	68400	46,191	22209	68%
Nov	64800	36,134	28666	56%
Dec	61200	31,983	29217	52%
Total	942300	637465	306057	68%

The "usage" column shows your historic usage for the past year.

The "Solar" column shows the expected production of the system based on historic weather data, roof orientation & angle.

The "Net" column represents your monthly usage after you install solar which shows your usage less the solar production giving you the "Net" consumption from the grid.

When your "Net" consumption is negative it is shown in **red**. This means in that month that you produced more electricity than you used resulting in over production. Over production isn't necessarily bad, but we typically recommend sizing systems for minimal over production.

The "Percent" column represents how much of your expected net usage is offset by solar. So for any given month you can see that your expected usage will be ___% "solar powered". However, this is not the expected percent of utility bill savings, that will vary depending on your utility's rate structure.



Production comparison in kilowatt hours (KWH)

Middle School - 25-0710-01

Month	Historic Usage	260kWdc/200kWac		
		Solar Production	Net	Percent
Jan	68800	22,040	46760	32%
Feb	55360	21,569	33791	39%
Mar	39840	31,920	7920	80%
Apr	48480	33,610	14870	69%
May	41440	39,483	1957	95%
Jun	58880	40,045	18835	68%
Jul	69920	42,693	27227	61%
Aug	77120	38,173	38947	49%
Sep	61760	32,441	29319	53%
Oct	45920	26,454	19466	58%
Nov	60960	20,578	40382	34%
Dec	64960	18,142	46818	28%
Total	693440	367148	326292	53%

The "usage" column shows your historic usage for the past year.

The "Solar" column shows the expected production of the system based on historic weather data, roof orientation & angle.

The "Net" column represents your monthly usage after you install solar which shows your usage less the solar production giving you the "Net" consumption from the grid.

When your "Net" consumption is negative it is shown in **red**. This means in that month that you produced more electricity than you used resulting in over production. Over production isn't necessarily bad, but we typically recommend sizing systems for minimal over production.

The "Percent" column represents how much of your expected net usage is offset by solar. So for any given month you can see that your expected usage will be ___% "solar powered". However, this is not the expected percent of utility bill savings, that will vary depending on your utility's rate structure.

Appendix L. page 48

		2027																													
		Weeks																													
		June 15th is the 25th week of 2026																													
		July 4th																													
		25	26	27	28	29	30	31	32	33	34	35	36	37	38	39	40	41	42	43	44	45	46	47	48	49	50	51	52	53	
Milestone	Assigned to	Start date	Duration																												
Bids due	Mark	26-May																													
Notice of award	USD 413	15-Jun																													
Invoice down payment	Kendra	16-Jun	1-day																												
Document safe harbor material	Mark	16-Jun	1-day																												
Remit payment	USD 413	22-Jun	1-day																												
Transfer ownership of safe harbor material	Mark	23-Jun	1-day																												
Design	Mark	29-Jun	4-weeks																												
Engineering	Mark	13-Jul	4-weeks																												
Permit	Kenzie	10-Aug	4-weeks																												
Interconnection	Kenzie	10-Aug	4-weeks																												
Utility studies (if needed)	City	24-Aug	90-days																												
Procurement	Taylor	7-Sep	12-weeks																												
Buffer (weather, material delays, etc)	--	1-Dec	3-weeks																												
Mobilize	Taylor/Shane	16-Nov	2-weeks																												
Elementary electrical	Philip	21-Dec	1-week																												
King Solar holiday	--	24-Dec	10-days																												
Rooftop at Elementary school	Josh	4-Jan	4-weeks																												
Testing, inspection, commissioning Elementary	Philip/Mark	25-Jan	2-weeks																												
High School East, West & Weld electrical/trench	Kelley/Spencer	4-Jan	4-weeks																												
Foundations for HS campus	Davis	11-Jan	2-weeks																												
Ground racking for HS campus	Davis	25-Jan	2-weeks																												
Modules for ground systems at HS campus	Davis	8-Feb	2-weeks																												
DC wiring for ground systems at HS campus	Spencer	15-Feb	2-weeks																												
Fencing for ground systems at HS campus	Mark/Sub	22-Feb	2-weeks																												
Testing, inspection, commissioning HS-west/weld	Spencer/Mark	1-Mar	2-weeks																												
Rooftop at HS-East	Josh	1-Mar	3-weeks																												
Testing, inspection, commissioning HS-East	Spencer/Mark	22-Mar	2-weeks																												
Buffer (weather, material delays, etc)	--	5-Apr	3-weeks																												
Rooftop Middle School	Josh/Davis	26-Apr	4-weeks																												
Electrical Middle School (concrete cut/repair)	Philip	10-May	4-weeks																												
Testing, inspection, commissioning Middle School	Philip/Mark	7-Jun	2-weeks																												
Training/walk-thru/monitoring setup	USD 413/Mark	14-Jun	1-week																												
Final invoice and hand-off	USD 413/Mark	21-Jun	1-week																												
District final payment	USD 413	1-Jul	1-day																												
Buffer (weather, material delays, etc)	--	21-Jun	5-weeks																												

USD 413 Solar
 King Solar Inc.
 Mark Horst - Project Manager
 Project start date: 6/15/26

2-Aug-27
 28 29 30



Phone: (316) 265-8568
Email: mark@kingsolar.net

Appendix M. page 49

Date: 23-May-26
Re: Inventory allocation for safe harboring 2026 tax credit
Customer: XYZ company
Address: 000 Name St. City, KS

Project size in kW: ###.#kWdc
Project total: \$____.00
Payment received prior to 7/4/2026: \$____.00

To whom it may concern,

The customer listed above has entered into an agreement with King Solar to purchase and construct a solar project located at the address listed above. In order to comply with the IRS's safe harboring requirements for the solar investment tax credit, King Solar is transferring ownership of the inventory listed below to the customer as of 7/1/2026. This inventory is being stored at King Solar's warehouse located at 2615 Switzer Rd. Hutchinson, KS 67501.

Pallet numbers: ____
Product: [brand] [model] [wattage]
Location in warehouse: Bay ____

Photo:



Let me know if you have any questions,



Mark Horst, President
King Solar Inc.
316-265-8568



Appendix N. page 50

King Solar includes the following service in the base proposal:

- **King Solar support**
 - Initial set-up and periodic updating of customer's monitoring portal and user account(s)
 - Remote diagnostics and trouble shooting based on customer's inquiry/notification
 - Filing manufacturer warranty claims & returning warranty replacement parts
 - Labor & mileage for service work billed at the time work is performed at current labor rates
 - As of today those rates are \$95/hr and \$0.70 per mile
 - Preventative maintenance done at current labor rates based on customer request

- **Manufacturer (SolarEdge & Fronius) supplied monitoring & service**
 - Lifetime monitoring utilizing customer supplied internet connection
 - Solar performance
 - AC power, energy, voltage & current
 - DC voltage
 - Environmental data
 - POA irradiance
 - Portal access for multiple user accounts
 - Settable alert parameters

Preventative maintenance inspection at approximately 1-year after installation included with base proposal:

- Visual inspection of all components
- Spot check mechanical torque of racking hardware
- Physical voltage readings AC & DC
- Remove debris from any roof drainage pathways
- Thermal imaging of electrical connections to identify hotspots/loose connections
- Open all cabinets & enclosures to check for rodent/insect/water intrusion
- Provide inspection report to customer for review & decision making
 - Any issues identified will be handled as follows
 - Manufacturer warranty defects will be handled under the base service offering
 - Workmanship warranty defects will be covered by King Solar
 - Issues due to weather, vandalism, acts of God or normal wear & tear will be handled by providing an estimate to the customer for approval prior to performing scope of work and will be billed accordingly
- Report provided to customer based on the above

OPTION: To add additional years of preventative maintenance inspections at time of initial purchase, add \$16 per kWdc per year. The scope to be the same as year #1:



CERTIFICATE OF LIABILITY INSURANCE

DATE (MM/DD/YYYY)

9/25/2025

THIS CERTIFICATE IS ISSUED AS A MATTER OF INFORMATION ONLY AND CONFERS NO RIGHTS UPON THE CERTIFICATE HOLDER. THIS CERTIFICATE DOES NOT AFFIRMATIVELY OR NEGATIVELY AMEND, EXTEND OR ALTER THE COVERAGE AFFORDED BY THE POLICIES BELOW.

IMPORTANT: If the certificate holder is an ADDITIONAL INSURED, the policy(ies) must have ADDITIONAL INSURED provisions or be endorsed. If SUBROGATION IS WAIVED, subject to the terms and conditions of the policy, certain policies may require an endorsement.

PRODUCER: Fuqua Insurance Group, Box 726, Hesston, KS 67062. CONTACT NAME, PHONE (620) 327-2388, FAX (620) 327-2707. INSURER(S) AFFORDING COVERAGE: Acuity, NAIC # 14184. INSURED: King Solar Inc., PO Box 101, Yoder, KS 67585.

COVERAGES CERTIFICATE NUMBER: REVISION NUMBER:

THIS IS TO CERTIFY THAT THE POLICIES OF INSURANCE LISTED BELOW HAVE BEEN ISSUED TO THE INSURED NAMED ABOVE FOR THE POLICY PERIOD INDICATED. NOTWITHSTANDING ANY REQUIREMENT, TERM OR CONDITION OF ANY CONTRACT OR OTHER DOCUMENT WITH RESPECT TO WHICH THIS CERTIFICATE MAY BE ISSUED OR MAY PERTAIN, THE INSURANCE AFFORDED BY THE POLICIES DESCRIBED HEREIN IS SUBJECT TO ALL THE TERMS, EXCLUSIONS AND CONDITIONS OF SUCH POLICIES.

Table with columns: INSR LTR, TYPE OF INSURANCE, ADDL INSD, SUBR WVD, POLICY NUMBER, POLICY EFF (MM/DD/YYYY), POLICY EXP (MM/DD/YYYY), LIMITS. Rows include Commercial General Liability, Automobile Liability, Umbrella Liab, Workers Compensation and Employers' Liability, and Commercial Inland Ma.

DESCRIPTION OF OPERATIONS / LOCATIONS / VEHICLES (ACORD 101, Additional Remarks Schedule, may be attached if more space is required) This certificate does not amend, extend or alter the coverage afforded by the policies listed.

Inventory is insured under Business Personal Property with limit of \$982,000.

CERTIFICATE HOLDER CANCELLATION

SHOULD ANY OF THE ABOVE DESCRIBED POLICIES BE CANCELLED BEFORE THE EXPIRATION DATE THEREOF, NOTICE WILL BE DELIVERED IN ACCORDANCE WITH THE POLICY PROVISIONS. AUTHORIZED REPRESENTATIVE: Krystle M. Walker



Appendix P. page 52

BID BOND

KNOW ALL MEN BY THESE PRESENTS: That we, King Solar Inc.
PO Box 101, Yoder KS 67585

as Principal, and the EMPLOYERS MUTUAL CASUALTY COMPANY, a corporation organized and existing under
the laws of the State of Iowa and authorized to do business in the State of Kansas

_____, as Surety, are held and firmly bound unto the
USD 413 Chanute Public Schools

as obligee, in the sum of Five (5%) of the total bid-----
----- DOLLARS, lawful money of the United

States of America, to the payment of which sum of money well and truly to be made, the said Principal and Surety
bind themselves, their and each of their heirs, executors, administrators, successors and assigns, jointly and
severally, by these presents.

THE CONDITION OF THIS OBLIGATION IS SUCH, that, if the Obligee shall make any award to the Principal for:
Installation of solar systems at the Chanute High School, Middle School & Elementary School

according to the terms of the proposal or bid made by the Principal therefor, and the Principal shall duly make and
enter into a contract with the Obligee in accordance with the terms of such proposal or bid and award and shall give
bond for the faithful performance thereof, with the EMPLOYERS MUTUAL CASUALTY COMPANY as Surety or
with other Surety or Sureties approved by the Obligee; or if the Principal shall, in case of failure so to do, pay to the
Obligee the damages which the Obligee may suffer by reason of such failure not exceeding the penalty of this bond,
then this obligation shall be null and void; otherwise it shall be and remain in full force and effect.

Signed, Sealed and Dated this 22 day of May, 20 26.

Jessica Setzer
Witness

King Solar Inc.
Principal

By: Mark Horst
Mark Horst, Owner
Employers Mutual Casualty Company
Surety

By: Krystle M. Walker
Krystle M. Walker
Attorney-in-Fact

Questions regarding this bond should be directed to the EMC H.O. Bond Department at 515-345-2689.

POWER OF ATTORNEY APPOINTING INDIVIDUAL ATTORNEY-IN-FACT

KNOW ALL MEN BY THESE PRESENTS, that:

- 1. Employers Mutual Casualty Company, an Iowa Corporation
- 2. EMCASCO Insurance Company, an Iowa Corporation
- 3. Union Insurance Company of Providence, an Iowa Corporation
- 4. Illinois EMCASCO Insurance Company, an Iowa Corporation
- 5. Dakota Fire Insurance Company, a North Dakota Corporation
- 6. EMC Property & Casualty Company, an Iowa Corporation

hereinafter referred to severally as "Company" and collectively as "Companies", each does, by these presents, make, constitute and appoint:

KRYSTLE M WALKER

its true and lawful attorney-in-fact, with full power and authority conferred to sign, seal, and execute the Bid Bond

In an amount not exceeding Ten Million Dollars.....\$10,000,000.00

and to bind each Company thereby as fully and to the same extent as if such instruments were signed by the duly authorized officers of each such Company, and all of the acts of said attorney pursuant to the authority hereby given are hereby ratified and confirmed.

AUTHORITY FOR POWER OF ATTORNEY

This Power-of-Attorney is made and executed pursuant to and by the authority of the following resolution of the Boards of Directors of each of the Companies at the first regularly scheduled meeting of each company duly called and held in 1999:

RESOLVED: The President and Chief Executive Officer, any Vice President, the Treasurer and the Secretary of Employers Mutual Casualty Company shall have power and authority to (1) appoint attorneys-in-fact and authorize them to execute on behalf of each Company and attach the seal of the Company thereto, bonds and undertakings, recognizances, contracts of indemnity and other writings obligatory in the nature thereof; and (2) to remove any such attorney-in-fact at any time and revoke the power and authority given to him or her. Attorneys-in-fact shall have power and authority, subject to the terms and limitations of the power-of-attorney issued to them, to execute and deliver on behalf of the Company, and to attach the seal of the Company thereto, bonds and undertakings, recognizances, contracts of indemnity and other writings obligatory in the nature thereof, and any such instrument executed by any such attorney-in-fact shall be fully and in all respects binding upon the Company. Certification as to the validity of any power-of-attorney authorized herein made by an officer of Employers Mutual Casualty Company shall be fully and in all respects binding upon this Company. The facsimile or mechanically reproduced signature of such officer, whether made heretofore or hereafter, wherever appearing upon a certified copy of any power-of-attorney of the Company, shall be valid and binding upon the Company with the same force and effect as though manually affixed.

IN WITNESS THEREOF, the Companies have caused these presents to be signed for each by their officers as shown, and the Corporate seals to be hereto affixed this 17th day of September, 2025.

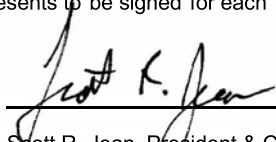

Scott R. Jean, President & CEO
of Company 1; Chairman, President
& CEO of Companies 2, 3, 4, 5 & 6



Todd Strother, Executive Vice President
Chief Legal Officer & Secretary of
Companies 1, 2, 3, 4, 5 & 6

Seals

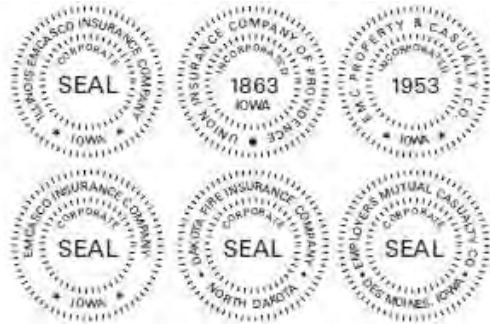

On this 17th day of September, 2025 before me a Notary Public in and for the State of Iowa, personally appeared Scott R. Jean and Todd Strother, who, being by me duly sworn, did say that they are, and are known to me to be the CEO, Chairman, President, Executive Vice President, Chief Legal Officer and/or Secretary, respectively, of each of the Companies above; that the seals affixed to this instrument are the seals of said corporations; that said instrument was signed and sealed on behalf of each of the Companies by authority of their respective Boards of Directors; and that the said Scott R. Jean and Todd Strother, as such officers, acknowledged the execution of said instrument to be their voluntary act and deed, and the voluntary act and deed of each of the Companies.

My Commission Expires August 13, 2028.

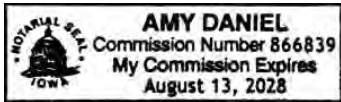



Notary Public in and for the State of Iowa

CERTIFICATE

I, Ryan J. Springer, Vice President of the Companies, do hereby certify that the foregoing resolution of the Boards of Directors by each of the Companies, and this Power of Attorney issued pursuant thereto on 17th day of September, 2025, are true and correct and are still in full force and effect. In Testimony Whereof I have subscribed my name and affixed the facsimile seal of each Company this _____ day of _____, _____.

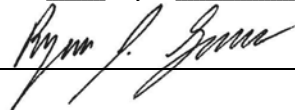

Vice President



Certificate of Completion

Summary

Title	Bid Bond
File name	Bid Bond.pdf
Status	Completed
Document guid:	MI31YZzAzOZDz4Gq6Pu40P9vnJVmo_fb
Number of pages	3
Number of e-signatures	1

Document History

2026-05-22 04:45:21 PM CDT	Signed by Mark Horst (mark@kingsolar.net) IP 209.137.206.92
2026-05-22 04:45:22 PM CDT	Electronic record and signature disclosure agreed by Mark Horst (mark@kingsolar.net) IP 209.137.206.92



Appendix Q. CONFIDENTIAL

page 55

November 15, 2023

RE: Domestic Content Certification – Preformed Line Products Company

To Whom It May Concern:

Preformed Line Products Company hereby certifies that to the best of its knowledge and belief, the Preformed Line Products Company products listed below will be 100% produced within the United States.

Sales Part Number	Description
5803006-178000	STEEL I-BEAM, W6x8.5, 178" LENGTH
5810420-40-SS	PA RAD GROUNDED END CLAMP SS
5803066-3440-SS	PA RAD Amp Mid CLAMP SS 34-40mm
5803050	Strut Attachment Asy Pwr Peak
5803049	STRUT ATTACHMENT FULLY ASSEMBLED
5803040-135-UD-67625-S	Strongback Assembly PPM-135 Strongb
5803033-246	UD MODULE RAIL - 246" LONG
5803044	UD SPLICE KIT

Name: John M. Hofstetter
Title: Executive Vice President, U.S. Operations

Signature

PLP.COM



We Have FEOC-Compliant Products

Major solar tax changes took effect on January 1st, 2026. The 30% residential ITC (25D) is gone, but the commercial 48E credit remains available for third-party ownership structures like leases, PPAs, and prepaid PPAs.

Bonus credits, like those for domestic content, also remain for commercial taxpayers. To receive the 48E 30% base credit, projects are now required to meet new Foreign Entity of Concern (FEOC) material thresholds.*

New FEOC Feature in Design Assistant

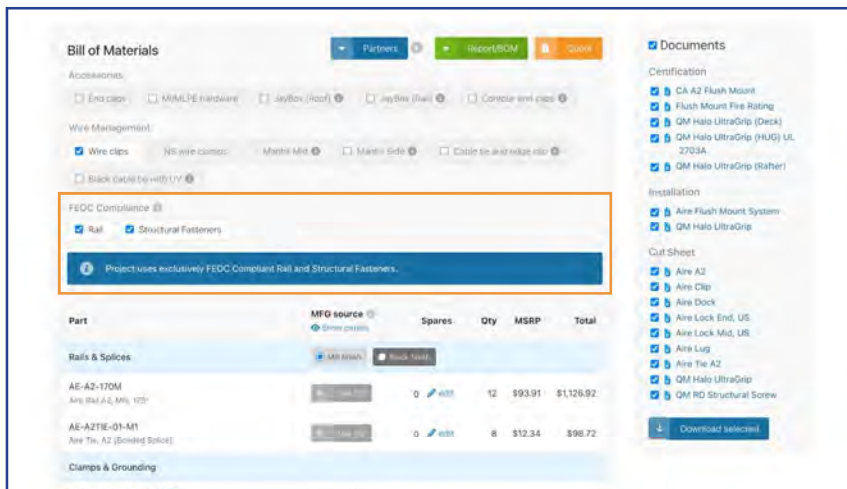

FEOC CONFIRMATIONS

There is now a “FEOC Compliance” section on the Bill of Materials page in Design Assistant, where users can select *Rail* and *Structural Fasteners*. A blue notification will confirm that all project parts meet compliance.

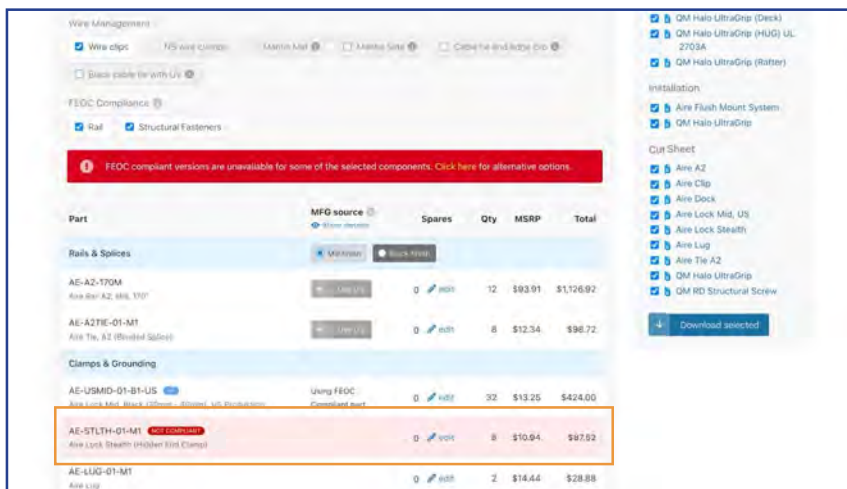

ALTERNATIVE OPTIONS

When a project design is using any “non-compliant” parts, a red notification banner will show instead. There is a table provided that lists alternative parts that should be swapped to for compliance.



Scan the QR code to visit our webpage dedicated to FEOC Compliance: IronRidge.com/FEOC

*IronRidge does not provide tax, legal or accounting advice. This material has been prepared for informational purposes only and is not intended to be relied upon in place of professional advice. See full disclaimer and other details on our FEOC Compliance webpage.



Domestic Content: Treasury Notice 2025-08

IronRidge offers racking systems that use 100% domestically-produced components. Our products made in the United States include rails, structural fasteners, roof attachments, and BX Ballasted System.

To meet the qualifying criteria for tax credit incentives, solar projects must use a combination of modules, inverters (MLPE or String), and racking with a minimum aggregate threshold of 50% Domestic Content.*

Pathway to 50%*



NO NEED TO SETTLE

Pick reputable products that your crews like installing. IronRidge offerings are listed to UL 2703 and UL 3741, tested rigorously, and made with the highest quality standards.



DO YOUR HOMEWORK

Understand terms and definitions. Obtain letters from the manufacturer to share with your tax and legal counsel. Make sure they can also provide traceability in case of audit.



STACK MANUFACTURERS

IronRidge has partnerships with the leading inverter manufacturers. This allows our customers to have multiple avenues for them to reach the 50% domestic threshold.*

Avoid the Pitfalls



READ THE FINE PRINT

Only taxpayers offering third-party-owned systems and other commercial entities are eligible. Installation companies and home owners do not directly qualify.



BE FULLY PREPARED

Audits by financiers, commercial project owners, other taxpayers, and the IRS are serious business. Ensure manufacturing partners can help you navigate potential oversight.



STAY IN THE KNOW

The Bonus Credit is complex and nuanced. We provide resources pertinent to our customers. IronRidge does not give tax or legal advice – consult your own counsel.



Scan the QR code to visit our webpage dedicated to Domestic Content: IronRidge.com/DC

**IronRidge does not provide tax, legal or accounting advice. This material has been prepared for informational purposes only and is not intended to be relied upon in place of professional advice. See full disclaimer and other details on our Domestic Content webpage.*

NABCEP®

Raising Standards. Promoting Confidence.



The North American Board of Certified Energy Practitioners

does hereby recognize that

PV Installation Professional

MARK HORST

has satisfied the requirements and standards for the

PV Installation Professional

established by the NABCEP Board of Directors.

Certification # PV-101913-002307

Expires 12/19/2028

A handwritten signature in black ink that reads "Donald B. Warfield".

Donald B. Warfield, Board Chairman

To verify current status visit www.nabcep.org

2026-0010934
KING SOLAR, INC
PO BOX 101
YODER, KS 67585

Appendix S.
Page 59

JOHNSON COUNTY, KANSAS
CONTRACTOR LICENSING PROGRAM

Hereby grants the following:

Class DE - Electrical Contractor

2026 CONTRACTOR LICENSE
TO

KING SOLAR, INC

ISSUED BY:
Contractor Licensing Program
Johnson County, KS
111 South Cherry Street, #1000
Olathe, KS 66061

LICENSE EXPIRES DECEMBER 31, 2026

Contractor License

License Number: BUS2017-09675

ELE - Electrical Contractor

License Expires: 12/31/2027

License Holder Information:

King Solar Inc EC
2615 SWITZER RD
HUTCHINSON, KS 67501

License Valid: 12/11/2025 thru 12/31/2027

Renewal Date: 9/1/2027

Phone & Email Information:

(316)265-8568
mark@kingsolar.net

Qualified Person:

Mark Horst

State Registration Number: N/A

IVR / Tellus Access: EXPD

Portal Access: 09675

Fees Paid

<u>Receipt Number</u>	<u>Date Paid</u>	<u>Fee</u>	<u>Amount Paid</u>
326921	12/11/2025	Electrical License	\$360.00



**Metropolitan
Area Building
& Construction
Department**

State of Missouri
Division of Professional Registration
Electrical Contractor

VALID THROUGH SEPTEMBER 30, 2026
ORIGINAL CERTIFICATE/LICENSE NO. 2026001054
MARK HORST
PO BOX 101
YODER KS 67585
UNITED STATES



State of Missouri

Missouri Department of Commerce and Insurance
Division of Professional Registration
Office of Statewide Electrical Contractors
Electrical Contractor

VALID THROUGH SEPTEMBER 30, 2026
ORIGINAL CERTIFICATE/LICENSE NO. 2026001054

MARK HORST
PO BOX 101
YODER KS 67585
UNITED STATES



Brian Baierth
EXECUTIVE DIRECTOR

Sheila Solon
DIVISION DIRECTOR

YOUR SOLAR PROJECT WILL IMPACT CHANUTE PUBLIC SCHOOLS FOR OVER 30 YEARS

Energy costs continue to rise, increasing the financial burden on Chanute Public Schools, which currently spends \$22,028 annually on electricity.
A Brightwell solar project can change this future.

Lower Costs

A better way to buy electricity *just arrived*

Electricity is a non-negotiable expense, but how you purchase it can be reimagined. A Brightwell solar project allows Chanute Public Schools to lock in a lower cost of solar energy in year one while protecting against future rate increases. The 96 kW PV system will offset 80% of your facility's energy consumption, transforming \$582,211 of operating expenses into long-term cost savings that can go back into the programs and services that matter most.

GOING SOLAR IS AN EASY DECISION



Reduce Electric Costs

Switching to solar reduces electricity costs immediately and provides a long-term hedge against rising rates. By not going solar, Chanute Public Schools risks continued exposure to unpredictable utility price increases.



Manage Capital Outlay

With Brightwell's Energy Management Service Agreement (EMSA), you can procure solar energy for less than the project price. Simply sign the agreement, pay a fraction of the project price at installation, and receive predictable energy costs through solar.



Flexibility to Buyout

The Brightwell EMSA provides the option to purchase the solar system in the future, shifting even more savings back to Chanute Public Schools and increasing long-term financial benefits.

About the Solar Project

Chanute Public Schools

HS-A HS Welding Shop
96 kW Solar PV System

Energy Offset:	80%
# of Solar Panels:	160
Annual Production:	142,337 kWh
Carbon Reduction:	111 tons



\$582,211
30-yr Energy Offset
Energy cost offset without investing a dollar towards a solar system

4.27 GWh
Estimated 30-yr Energy Production
Estimated energy kWh production from solar over the system's targeted lifecycle

6.67M
Total lbs CO₂ Offset (30-yr)
Equivalent to carbon sequestered by 120 acres of U.S. forests in one year



About the Solar Installer Partner

King Solar and Brightwell combine decades of experience in solar design and installation, structural engineering, NABCEP-certified specialists, and tax incentives experts. We utilize only proven Bloomberg Tier-1 rated solar panels and system technologies backed by industry-leading product and performance guarantees. King Solar and Brightwell are committed to delivering best-in-class service that creates raving fans.



Projected Cash Flow: HS-A HS Welding Shop

YEAR	SAVINGS POST-SOLAR	EMSA	INSURANCE	ANNUAL CASH FLOW	CUMULATIVE CASH FLOW
2027	\$16,929	(\$15,900)	-	\$1,029	\$1,029
2028	\$17,572	(\$15,900)	-	\$1,672	\$2,701
2029	\$18,240	(\$15,900)	-	\$2,340	\$5,041
2030	\$18,933	(\$15,900)	-	\$3,033	\$8,074
2031	\$19,652	(\$15,900)	-	\$3,752	\$11,826
2032	\$20,399	(\$15,900)	-	\$4,499	\$16,325
2033	\$21,174	(\$15,900)	-	\$5,274	\$21,599
2034	\$21,979	(\$15,900)	-	\$6,079	\$27,678
2035	\$22,814	(\$15,900)	-	\$6,914	\$34,592
2036	\$23,681	(\$15,900)	-	\$7,781	\$42,373
2037	\$24,581	(\$15,900)	-	\$8,681	\$51,054
2038	\$25,515	(\$15,900)	-	\$9,615	\$60,669
2039	\$26,485	(\$15,900)	-	\$10,585	\$71,254
2040	\$27,491	(\$15,900)	-	\$11,591	\$82,845
2041	\$28,536	(\$15,900)	-	\$12,636	\$95,481
2042	\$29,620	(\$15,900)	-	\$13,720	\$109,201
2043	\$30,746	(\$15,900)	-	\$14,846	\$124,047
2044	\$31,914	(\$15,900)	-	\$16,014	\$140,061
2045	\$33,127	(\$15,900)	-	\$17,227	\$157,288
2046	\$34,385	(\$15,900)	-	\$18,485	\$175,773
2047	\$35,692	-	(\$1,656)	\$34,036	\$209,809
2048	\$37,048	-	(\$1,689)	\$35,359	\$245,168
2049	\$38,456	-	(\$1,723)	\$36,733	\$281,901
2050	\$39,918	-	(\$1,757)	\$38,161	\$320,062
2051	\$41,434	-	(\$1,792)	\$39,642	\$359,704
2052	\$43,009	-	(\$1,828)	\$41,181	\$400,885
2053	\$44,643	-	(\$1,865)	\$42,778	\$443,663
2054	\$46,340	-	(\$1,902)	\$44,438	\$488,101
2055	\$48,101	-	(\$1,940)	\$46,161	\$534,262
2056	\$49,928	-	(\$1,979)	\$47,949	\$582,211

* Insurance costs at year 21 are an estimate for a separate policy; alternatively the coverage can be rolled into the existing P & L policy.

Frequently Asked Questions

How does this affect our insurance?

When going solar, the impact investor maintains general liability, excess liability, and property liability insurance. Brightwell will provide a **Certificate of Insurance (COI)** to the organization, which can be shared with the organization's insurance carrier. If your roof has a claim, the deductible will cover the uninstall - reinstall cost.

Will this affect our roof?

When installing solar, we evaluate your roof to optimize installation. We work with the installer to limit penetrations and obtain a structural engineer's stamp. **This is backed by a 5-year craftsmanship warranty, alleviating any roof concerns.**

Who services the panels?

Solar panels require minimal maintenance. However, the **EMSA includes monitoring and an annual maintenance inspection** to keep the system in peak condition.

Does Brightwell have solar expertise?

Design & Installation—Brightwell ensures top-tier energy solutions with an in-house team of solar architects, installation teams, structural engineers, certified electricians, and NABCEP PVIP-certified professionals. The Brightwell team has experience installing over 20 MW of solar projects.

What happens in bad weather?

Solar panels undergo rigorous testing during the manufacturing process to ensure their durability and resilience in harsh conditions. This includes exposure to extreme temperatures, humidity, and other environmental stressors.

Hail Warranty—Panels typically have warranties that cover up to 1" hail at 51.6 mph.

What happens if we have to repair our roof—do we have to take the panels off and put them back on?

The panels protect the portion of the roof they are on top of but if the roof is damaged requiring a re-roof, this will require an uninstall - reinstall of the solar system. In this situation, it could be 5-15% of the roof cost but this cost is covered by the same deductible as the deductible you pay for your roof. The system will be taken down, stored in a safe location, and reinstalled once the roof is complete.

What type of products does Brightwell use?

Brightwell focuses on top tier products that have the industries longest warranties to ensure our projects last for decades.

Tier 1 Designation. The bankable Tier 1 ranking is a classification system signifies a company is considered highly reliable and has a strong financial standing, making it more likely for banks to provide loans for projects using their panels. Ratings of solar companies as top-tier solar panel producers based on their financial strength and production capacity.

Industry Leading Warranties. The solar panels, inverters, and racking systems have best-in-class 25-year product warranties and 30-year panel performance warranties.

YOUR SOLAR PROJECT WILL IMPACT CHANUTE PUBLIC SCHOOL FOR OVER 30 YEARS

Energy costs continue to rise, increasing the financial burden on Chanute Public School, which currently spends \$112,346 annually on electricity. **A Brightwell solar project can change this future.**

Lower Costs

A better way to buy electricity *just arrived*

Electricity is a non-negotiable expense, but how you purchase it can be reimagined. A Brightwell solar project allows Chanute Public School to lock in a lower cost of solar energy in year one while protecting against future rate increases. The 251 kW PV system will offset 41% of your facility's energy consumption, transforming \$1,505,285 of operating expenses into long-term cost savings that can go back into the programs and services that matter most.

GOING SOLAR IS AN EASY DECISION



Reduce Electric Costs

Switching to solar reduces electricity costs immediately and provides a long-term hedge against rising rates. By not going solar, Chanute Public School risks continued exposure to unpredictable utility price increases.



Manage Capital Outlay

With Brightwell's Energy Management Service Agreement (EMSA), you can procure solar energy for less than the project price. Simply sign the agreement, pay a fraction of the project price at installation, and receive predictable energy costs through solar.



Flexibility to Buyout

The Brightwell EMSA provides the option to purchase the solar system in the future, shifting even more savings back to Chanute Public School and increasing long-term financial benefits.



About the Solar Project

Chanute Public School

HS-B HS West Feeder

251 kW Solar PV System

Energy Offset: 41%

of Solar Panels: 418

Annual Production: 373,176 kWh

Carbon Reduction: 291 tons



\$1,505,285
30-yr Energy Offset
 Energy cost offset without investing a dollar towards a solar system

11.2 GWh
Estimated 30-yr Energy Production
 Estimated energy kWh production from solar over the system's targeted lifecycle

17.5M
Total lbs CO₂ Offset (30-yr)
 Equivalent to carbon sequestered by 315 acres of U.S. forests in one year



About the Solar Installer Partner

King Solar and Brightwell combine decades of experience in solar design and installation, structural engineering, NABCEP-certified specialists, and tax incentives experts. We utilize only proven Bloomberg Tier-1 rated solar panels and system technologies backed by industry-leading product and performance guarantees. King Solar and Brightwell are committed to delivering best-in-class service that creates raving fans.



Projected Cash Flow: HS-B HS West Feeder

YEAR	SAVINGS POST-SOLAR	EMSA	INSURANCE	ANNUAL CASH FLOW	CUMULATIVE CASH FLOW
2027	\$44,314	(\$42,300)	-	\$2,014	\$2,014
2028	\$45,998	(\$42,300)	-	\$3,698	\$5,712
2029	\$47,746	(\$42,300)	-	\$5,446	\$11,158
2030	\$49,561	(\$42,300)	-	\$7,261	\$18,419
2031	\$51,444	(\$42,300)	-	\$9,144	\$27,563
2032	\$53,399	(\$42,300)	-	\$11,099	\$38,662
2033	\$55,428	(\$42,300)	-	\$13,128	\$51,790
2034	\$57,534	(\$42,300)	-	\$15,234	\$67,024
2035	\$59,720	(\$42,300)	-	\$17,420	\$84,444
2036	\$61,990	(\$42,300)	-	\$19,690	\$104,134
2037	\$64,345	(\$42,300)	-	\$22,045	\$126,179
2038	\$66,791	(\$42,300)	-	\$24,491	\$150,670
2039	\$69,329	(\$42,300)	-	\$27,029	\$177,699
2040	\$71,963	(\$42,300)	-	\$29,663	\$207,362
2041	\$74,698	(\$42,300)	-	\$32,398	\$239,760
2042	\$77,536	(\$42,300)	-	\$35,236	\$274,996
2043	\$80,483	(\$42,300)	-	\$38,183	\$313,179
2044	\$83,541	(\$42,300)	-	\$41,241	\$354,420
2045	\$86,715	(\$42,300)	-	\$44,415	\$398,835
2046	\$90,011	(\$42,300)	-	\$47,711	\$446,546
2047	\$93,431	-	(\$4,809)	\$88,622	\$535,168
2048	\$96,981	-	(\$4,905)	\$92,076	\$627,244
2049	\$100,667	-	(\$5,003)	\$95,664	\$722,908
2050	\$104,492	-	(\$5,103)	\$99,389	\$822,297
2051	\$108,463	-	(\$5,205)	\$103,258	\$925,555
2052	\$112,584	-	(\$5,309)	\$107,275	\$1,032,830
2053	\$116,862	-	(\$5,415)	\$111,447	\$1,144,277
2054	\$121,303	-	(\$5,524)	\$115,779	\$1,260,056
2055	\$125,913	-	(\$5,634)	\$120,279	\$1,380,335
2056	\$130,697	-	(\$5,747)	\$124,950	\$1,505,285

* Insurance costs at year 21 are an estimate for a separate policy; alternatively the coverage can be rolled into the existing P & L policy.

Frequently Asked Questions

How does this affect our insurance?

When going solar, the impact investor maintains general liability, excess liability, and property liability insurance. Brightwell will provide a **Certificate of Insurance (COI)** to the organization, which can be shared with the organization's insurance carrier. If your roof has a claim, the deductible will cover the uninstall - reinstall cost.

Will this affect our roof?

When installing solar, we evaluate your roof to optimize installation. We work with the installer to limit penetrations and obtain a structural engineer's stamp. **This is backed by a 5-year craftsmanship warranty, alleviating any roof concerns.**

Who services the panels?

Solar panels require minimal maintenance. However, the **EMSA includes monitoring and an annual maintenance inspection** to keep the system in peak condition.

Does Brightwell have solar expertise?

Design & Installation—Brightwell ensures top-tier energy solutions with an in-house team of solar architects, installation teams, structural engineers, certified electricians, and NABCEP PVIP-certified professionals. The Brightwell team has experience installing over 20 MW of solar projects.

What happens in bad weather?

Solar panels undergo rigorous testing during the manufacturing process to ensure their durability and resilience in harsh conditions. This includes exposure to extreme temperatures, humidity, and other environmental stressors.

Hail Warranty—Panels typically have warranties that cover up to 1" hail at 51.6 mph.

What happens if we have to repair our roof—do we have to take the panels off and put them back on?

The panels protect the portion of the roof they are on top of but if the roof is damaged requiring a re-roof, this will require an uninstall - reinstall of the solar system. In this situation, it could be 5-15% of the roof cost but this cost is covered by the same deductible as the deductible you pay for your roof. The system will be taken down, stored in a safe location, and reinstalled once the roof is complete.

What type of products does Brightwell use?

Brightwell focuses on top tier products that have the industries longest warranties to ensure our projects last for decades.

Tier 1 Designation. The bankable Tier 1 ranking is a classification system signifies a company is considered highly reliable and has a strong financial standing, making it more likely for banks to provide loans for projects using their panels. Ratings of solar companies as top-tier solar panel producers based on their financial strength and production capacity.

Industry Leading Warranties. The solar panels, inverters, and racking systems have best-in-class 25-year product warranties and 30-year panel performance warranties.

YOUR SOLAR PROJECT WILL IMPACT CHANUTE PUBLIC SCHOOLS FOR OVER 30 YEARS

Energy costs continue to rise, increasing the financial burden on Chanute Public Schools, which currently spends \$46,239 annually on electricity. **A Brightwell solar project can change this future.**

Lower Costs

A better way to buy electricity *just arrived*

Electricity is a non-negotiable expense, but how you purchase it can be reimagined. A Brightwell solar project allows Chanute Public Schools to lock in a lower cost of solar energy in year one while protecting against future rate increases. The 156 kW PV system will offset 63% of your facility's energy consumption, transforming \$967,154 of operating expenses into long-term cost savings that can go back into the programs and services that matter most.

GOING SOLAR IS AN EASY DECISION



Reduce Electric Costs

Switching to solar reduces electricity costs immediately and provides a long-term hedge against rising rates. By not going solar, Chanute Public Schools risks continued exposure to unpredictable utility price increases.



Manage Capital Outlay

With Brightwell's Energy Management Service Agreement (EMSA), you can procure solar energy for less than the project price. Simply sign the agreement, pay a fraction of the project price at installation, and receive predictable energy costs through solar.



Flexibility to Buyout

The Brightwell EMSA provides the option to purchase the solar system in the future, shifting even more savings back to Chanute Public Schools and increasing long-term financial benefits.

About the Solar Project

Chanute Public Schools

HS-C HS East Feeder
156 kW Solar PV System

Energy Offset:	63%
# of Solar Panels:	260
Annual Production:	227,671 kWh
Carbon Reduction:	178 tons



\$967,154
30-yr Energy Offset
Energy cost offset without investing a dollar towards a solar system

6.83 GWh
Estimated 30-yr Energy Production
Estimated energy kWh production from solar over the system's targeted lifecycle

10.7M
Total lbs CO₂ Offset (30-yr)
Equivalent to carbon sequestered by 192 acres of U.S. forests in one year



About the Solar Installer Partner

King Solar and Brightwell combine decades of experience in solar design and installation, structural engineering, NABCEP-certified specialists, and tax incentives experts. We utilize only proven Bloomberg Tier-1 rated solar panels and system technologies backed by industry-leading product and performance guarantees. King Solar and Brightwell are committed to delivering best-in-class service that creates raving fans.



Projected Cash Flow: HS-C HS East Feeder

YEAR	SAVINGS POST-SOLAR	EMSA	INSURANCE	ANNUAL CASH FLOW	CUMULATIVE CASH FLOW
2027	\$27,745	(\$25,400)	-	\$2,345	\$2,345
2028	\$28,799	(\$25,400)	-	\$3,399	\$5,744
2029	\$29,893	(\$25,400)	-	\$4,493	\$10,237
2030	\$31,029	(\$25,400)	-	\$5,629	\$15,866
2031	\$32,208	(\$25,400)	-	\$6,808	\$22,674
2032	\$33,432	(\$25,400)	-	\$8,032	\$30,706
2033	\$34,703	(\$25,400)	-	\$9,303	\$40,009
2034	\$36,021	(\$25,400)	-	\$10,621	\$50,630
2035	\$37,390	(\$25,400)	-	\$11,990	\$62,620
2036	\$38,811	(\$25,400)	-	\$13,411	\$76,031
2037	\$40,286	(\$25,400)	-	\$14,886	\$90,917
2038	\$41,817	(\$25,400)	-	\$16,417	\$107,334
2039	\$43,406	(\$25,400)	-	\$18,006	\$125,340
2040	\$45,055	(\$25,400)	-	\$19,655	\$144,995
2041	\$46,767	(\$25,400)	-	\$21,367	\$166,362
2042	\$48,545	(\$25,400)	-	\$23,145	\$189,507
2043	\$50,389	(\$25,400)	-	\$24,989	\$214,496
2044	\$52,304	(\$25,400)	-	\$26,904	\$241,400
2045	\$54,292	(\$25,400)	-	\$28,892	\$270,292
2046	\$56,355	(\$25,400)	-	\$30,955	\$301,247
2047	\$58,496	-	(\$2,733)	\$55,763	\$357,010
2048	\$60,719	-	(\$2,788)	\$57,931	\$414,941
2049	\$63,026	-	(\$2,843)	\$60,183	\$475,124
2050	\$65,421	-	(\$2,900)	\$62,521	\$537,645
2051	\$67,907	-	(\$2,958)	\$64,949	\$602,594
2052	\$70,488	-	(\$3,017)	\$67,471	\$670,065
2053	\$73,166	-	(\$3,078)	\$70,088	\$740,153
2054	\$75,947	-	(\$3,139)	\$72,808	\$812,961
2055	\$78,833	-	(\$3,202)	\$75,631	\$888,592
2056	\$81,828	-	(\$3,266)	\$78,562	\$967,154

* Insurance costs at year 21 are an estimate for a separate policy; alternatively the coverage can be rolled into the existing P & L policy.

Frequently Asked Questions

How does this affect our insurance?

When going solar, the impact investor maintains general liability, excess liability, and property liability insurance. Brightwell will provide a **Certificate of Insurance (COI)** to the organization, which can be shared with the organization's insurance carrier. If your roof has a claim, the deductible will cover the uninstall - reinstall cost.

Will this affect our roof?

When installing solar, we evaluate your roof to optimize installation. We work with the installer to limit penetrations and obtain a structural engineer's stamp. **This is backed by a 5-year craftsmanship warranty, alleviating any roof concerns.**

Who services the panels?

Solar panels require minimal maintenance. However, the **EMSA includes monitoring and an annual maintenance inspection** to keep the system in peak condition.

Does Brightwell have solar expertise?

Design & Installation—Brightwell ensures top-tier energy solutions with an in-house team of solar architects, installation teams, structural engineers, certified electricians, and NABCEP PVIP-certified professionals. The Brightwell team has experience installing over 20 MW of solar projects.

What happens in bad weather?

Solar panels undergo rigorous testing during the manufacturing process to ensure their durability and resilience in harsh conditions. This includes exposure to extreme temperatures, humidity, and other environmental stressors.

Hail Warranty—Panels typically have warranties that cover up to 1" hail at 51.6 mph.

What happens if we have to repair our roof—do we have to take the panels off and put them back on?

The panels protect the portion of the roof they are on top of but if the roof is damaged requiring a re-roof, this will require an uninstall - reinstall of the solar system. In this situation, it could be 5-15% of the roof cost but this cost is covered by the same deductible as the deductible you pay for your roof. The system will be taken down, stored in a safe location, and reinstalled once the roof is complete.

What type of products does Brightwell use?

Brightwell focuses on top tier products that have the industries longest warranties to ensure our projects last for decades.

Tier 1 Designation. The bankable Tier 1 ranking is a classification system signifies a company is considered highly reliable and has a strong financial standing, making it more likely for banks to provide loans for projects using their panels. Ratings of solar companies as top-tier solar panel producers based on their financial strength and production capacity.

Industry Leading Warranties. The solar panels, inverters, and racking systems have best-in-class 25-year product warranties and 30-year panel performance warranties.

YOUR SOLAR PROJECT WILL IMPACT CHANUTE PUBLIC SCHOOLS FOR OVER 30 YEARS

Energy costs continue to rise, increasing the financial burden on Chanute Public Schools, which currently spends \$118,320 annually on electricity. **A Brightwell solar project can change this future.**

Lower Costs

A better way to buy electricity *just arrived*

Electricity is a non-negotiable expense, but how you purchase it can be reimagined. A Brightwell solar project allows Chanute Public Schools to lock in a lower cost of solar energy in year one while protecting against future rate increases. The 332 kW PV system will offset 50% of your facility's energy consumption, transforming \$2,200,541 of operating expenses into long-term cost savings that can go back into the programs and services that matter most.

GOING SOLAR IS AN EASY DECISION



Reduce Electric Costs

Switching to solar reduces electricity costs immediately and provides a long-term hedge against rising rates. By not going solar, Chanute Public Schools risks continued exposure to unpredictable utility price increases.



Manage Capital Outlay

With Brightwell's Energy Management Service Agreement (EMSA), you can procure solar energy for less than the project price. Simply sign the agreement, pay a fraction of the project price at installation, and receive predictable energy costs through solar.



Flexibility to Buyout

The Brightwell EMSA provides the option to purchase the solar system in the future, shifting even more savings back to Chanute Public Schools and increasing long-term financial benefits.

About the Solar Project

Chanute Public Schools

Elementary School

332 kW Solar PV System

Energy Offset: 50%

of Solar Panels: 553

Annual Production: 473,538 kWh

Carbon Reduction: 370 tons



\$2,200,541
30-yr Energy Offset
 Energy cost offset without investing a dollar towards a solar system

14.21 GWh
Estimated 30-yr Energy Production
 Estimated energy kWh production from solar over the system's targeted lifecycle

22.2M
Total lbs CO₂ Offset (30-yr)
 Equivalent to carbon sequestered by 400 acres of U.S. forests in one year



About the Solar Installer Partner

King Solar and Brightwell combine decades of experience in solar design and installation, structural engineering, NABCEP-certified specialists, and tax incentives experts. We utilize only proven Bloomberg Tier-1 rated solar panels and system technologies backed by industry-leading product and performance guarantees. King Solar and Brightwell are committed to delivering best-in-class service that creates raving fans.



Projected Cash Flow: Elementary School

YEAR	SAVINGS POST-SOLAR	EMSA	INSURANCE	ANNUAL CASH FLOW	CUMULATIVE CASH FLOW
2027	\$57,312	(\$42,800)	-	\$14,512	\$14,512
2028	\$59,490	(\$42,800)	-	\$16,690	\$31,202
2029	\$61,751	(\$42,800)	-	\$18,951	\$50,153
2030	\$64,097	(\$42,800)	-	\$21,297	\$71,450
2031	\$66,533	(\$42,800)	-	\$23,733	\$95,183
2032	\$69,061	(\$42,800)	-	\$26,261	\$121,444
2033	\$71,685	(\$42,800)	-	\$28,885	\$150,329
2034	\$74,409	(\$42,800)	-	\$31,609	\$181,938
2035	\$77,237	(\$42,800)	-	\$34,437	\$216,375
2036	\$80,172	(\$42,800)	-	\$37,372	\$253,747
2037	\$83,219	(\$42,800)	-	\$40,419	\$294,166
2038	\$86,381	(\$42,800)	-	\$43,581	\$337,747
2039	\$89,663	(\$42,800)	-	\$46,863	\$384,610
2040	\$93,071	(\$42,800)	-	\$50,271	\$434,881
2041	\$96,607	(\$42,800)	-	\$53,807	\$488,688
2042	\$100,278	(\$42,800)	-	\$57,478	\$546,166
2043	\$104,089	(\$42,800)	-	\$61,289	\$607,455
2044	\$108,044	(\$42,800)	-	\$65,244	\$672,699
2045	\$112,150	(\$42,800)	-	\$69,350	\$742,049
2046	\$116,412	(\$42,800)	-	\$73,612	\$815,661
2047	\$120,835	-	(\$4,794)	\$116,041	\$931,702
2048	\$125,427	-	(\$4,890)	\$120,537	\$1,052,239
2049	\$130,193	-	(\$4,988)	\$125,205	\$1,177,444
2050	\$135,141	-	(\$5,088)	\$130,053	\$1,307,497
2051	\$140,276	-	(\$5,190)	\$135,086	\$1,442,583
2052	\$145,606	-	(\$5,293)	\$140,313	\$1,582,896
2053	\$151,139	-	(\$5,399)	\$145,740	\$1,728,636
2054	\$156,883	-	(\$5,507)	\$151,376	\$1,880,012
2055	\$162,844	-	(\$5,617)	\$157,227	\$2,037,239
2056	\$169,032	-	(\$5,730)	\$163,302	\$2,200,541

* Insurance costs at year 21 are an estimate for a separate policy; alternatively the coverage can be rolled into the existing P & L policy.

Frequently Asked Questions

How does this affect our insurance?

When going solar, the impact investor maintains general liability, excess liability, and property liability insurance. Brightwell will provide a **Certificate of Insurance (COI)** to the organization, which can be shared with the organization's insurance carrier. If your roof has a claim, the deductible will cover the uninstall - reinstall cost.

Will this affect our roof?

When installing solar, we evaluate your roof to optimize installation. We work with the installer to limit penetrations and obtain a structural engineer's stamp. **This is backed by a 5-year craftsmanship warranty, alleviating any roof concerns.**

Who services the panels?

Solar panels require minimal maintenance. However, the **EMSA includes monitoring and an annual maintenance inspection** to keep the system in peak condition.

Does Brightwell have solar expertise?

Design & Installation—Brightwell ensures top-tier energy solutions with an in-house team of solar architects, installation teams, structural engineers, certified electricians, and NABCEP PVIP-certified professionals. The Brightwell team has experience installing over 20 MW of solar projects.

What happens in bad weather?

Solar panels undergo rigorous testing during the manufacturing process to ensure their durability and resilience in harsh conditions. This includes exposure to extreme temperatures, humidity, and other environmental stressors.

Hail Warranty—Panels typically have warranties that cover up to 1" hail at 51.6 mph.

What happens if we have to repair our roof—do we have to take the panels off and put them back on?

The panels protect the portion of the roof they are on top of but if the roof is damaged requiring a re-roof, this will require an uninstall - reinstall of the solar system. In this situation, it could be 5-15% of the roof cost but this cost is covered by the same deductible as the deductible you pay for your roof. The system will be taken down, stored in a safe location, and reinstalled once the roof is complete.

What type of products does Brightwell use?

Brightwell focuses on top tier products that have the industries longest warranties to ensure our projects last for decades.

Tier 1 Designation. The bankable Tier 1 ranking is a classification system signifies a company is considered highly reliable and has a strong financial standing, making it more likely for banks to provide loans for projects using their panels. Ratings of solar companies as top-tier solar panel producers based on their financial strength and production capacity.

Industry Leading Warranties. The solar panels, inverters, and racking systems have best-in-class 25-year product warranties and 30-year panel performance warranties.

YOUR SOLAR PROJECT WILL IMPACT CHANUTE PUBLIC SCHOOLS FOR OVER 30 YEARS

Energy costs continue to rise, increasing the financial burden on Chanute Public Schools, which currently spends \$86,572 annually on electricity. **A Brightwell solar project can change this future.**

Lower Costs

A better way to buy electricity *just arrived*

Electricity is a non-negotiable expense, but how you purchase it can be reimagined. A Brightwell solar project allows Chanute Public Schools to lock in a lower cost of solar energy in year one while protecting against future rate increases. The 260 kW PV system will offset 53% of your facility's energy consumption, transforming \$1,615,254 of operating expenses into long-term cost savings that can go back into the programs and services that matter most.

GOING SOLAR IS AN EASY DECISION



Reduce Electric Costs

Switching to solar reduces electricity costs immediately and provides a long-term hedge against rising rates. By not going solar, Chanute Public Schools risks continued exposure to unpredictable utility price increases.



Manage Capital Outlay

With Brightwell's Energy Management Service Agreement (EMSA), you can procure solar energy for less than the project price. Simply sign the agreement, pay a fraction of the project price at installation, and receive predictable energy costs through solar.



Flexibility to Buyout

The Brightwell EMSA provides the option to purchase the solar system in the future, shifting even more savings back to Chanute Public Schools and increasing long-term financial benefits.

About the Solar Project

Chanute Public Schools

Middle School

260 kW Solar PV System

Energy Offset: 53%

of Solar Panels: 433

Annual Production: 367,148 kWh

Carbon Reduction: 287 tons



\$1,615,254
30-yr Energy Offset
 Energy cost offset without investing a dollar towards a solar system

11.01 GWh
Estimated 30-yr Energy Production
 Estimated energy kWh production from solar over the system's targeted lifecycle

17.2M
Total lbs CO₂ Offset (30-yr)
 Equivalent to carbon sequestered by 310 acres of U.S. forests in one year



About the Solar Installer Partner

King Solar and Brightwell combine decades of experience in solar design and installation, structural engineering, NABCEP-certified specialists, and tax incentives experts. We utilize only proven Bloomberg Tier-1 rated solar panels and system technologies backed by industry-leading product and performance guarantees. King Solar and Brightwell are committed to delivering best-in-class service that creates raving fans.



Projected Cash Flow: Middle School

YEAR	SAVINGS POST-SOLAR	EMSA	INSURANCE	ANNUAL CASH FLOW	CUMULATIVE CASH FLOW
2027	\$44,360	(\$37,300)	-	\$7,060	\$7,060
2028	\$46,046	(\$37,300)	-	\$8,746	\$15,806
2029	\$47,795	(\$37,300)	-	\$10,495	\$26,301
2030	\$49,612	(\$37,300)	-	\$12,312	\$38,613
2031	\$51,497	(\$37,300)	-	\$14,197	\$52,810
2032	\$53,454	(\$37,300)	-	\$16,154	\$68,964
2033	\$55,485	(\$37,300)	-	\$18,185	\$87,149
2034	\$57,593	(\$37,300)	-	\$20,293	\$107,442
2035	\$59,782	(\$37,300)	-	\$22,482	\$129,924
2036	\$62,054	(\$37,300)	-	\$24,754	\$154,678
2037	\$64,412	(\$37,300)	-	\$27,112	\$181,790
2038	\$66,859	(\$37,300)	-	\$29,559	\$211,349
2039	\$69,400	(\$37,300)	-	\$32,100	\$243,449
2040	\$72,037	(\$37,300)	-	\$34,737	\$278,186
2041	\$74,775	(\$37,300)	-	\$37,475	\$315,661
2042	\$77,616	(\$37,300)	-	\$40,316	\$355,977
2043	\$80,565	(\$37,300)	-	\$43,265	\$399,242
2044	\$83,627	(\$37,300)	-	\$46,327	\$445,569
2045	\$86,805	(\$37,300)	-	\$49,505	\$495,074
2046	\$90,103	(\$37,300)	-	\$52,803	\$547,877
2047	\$93,527	-	(\$4,124)	\$89,403	\$637,280
2048	\$97,081	-	(\$4,207)	\$92,874	\$730,154
2049	\$100,770	-	(\$4,291)	\$96,479	\$826,633
2050	\$104,600	-	(\$4,377)	\$100,223	\$926,856
2051	\$108,574	-	(\$4,464)	\$104,110	\$1,030,966
2052	\$112,700	-	(\$4,554)	\$108,146	\$1,139,112
2053	\$116,983	-	(\$4,645)	\$112,338	\$1,251,450
2054	\$121,428	-	(\$4,738)	\$116,690	\$1,368,140
2055	\$126,043	-	(\$4,832)	\$121,211	\$1,489,351
2056	\$130,832	-	(\$4,929)	\$125,903	\$1,615,254

* Insurance costs at year 21 are an estimate for a separate policy; alternatively the coverage can be rolled into the existing P & L policy.

Frequently Asked Questions

How does this affect our insurance?

When going solar, the impact investor maintains general liability, excess liability, and property liability insurance. Brightwell will provide a **Certificate of Insurance (COI)** to the organization, which can be shared with the organization's insurance carrier. If your roof has a claim, the deductible will cover the uninstall - reinstall cost.

Will this affect our roof?

When installing solar, we evaluate your roof to optimize installation. We work with the installer to limit penetrations and obtain a structural engineer's stamp. **This is backed by a 5-year craftsmanship warranty, alleviating any roof concerns.**

Who services the panels?

Solar panels require minimal maintenance. However, the **EMSA includes monitoring and an annual maintenance inspection** to keep the system in peak condition.

Does Brightwell have solar expertise?

Design & Installation—Brightwell ensures top-tier energy solutions with an in-house team of solar architects, installation teams, structural engineers, certified electricians, and NABCEP PVIP-certified professionals. The Brightwell team has experience installing over 20 MW of solar projects.

What happens in bad weather?

Solar panels undergo rigorous testing during the manufacturing process to ensure their durability and resilience in harsh conditions. This includes exposure to extreme temperatures, humidity, and other environmental stressors.

Hail Warranty—Panels typically have warranties that cover up to 1" hail at 51.6 mph.

What happens if we have to repair our roof—do we have to take the panels off and put them back on?

The panels protect the portion of the roof they are on top of but if the roof is damaged requiring a re-roof, this will require an uninstall - reinstall of the solar system. In this situation, it could be 5-15% of the roof cost but this cost is covered by the same deductible as the deductible you pay for your roof. The system will be taken down, stored in a safe location, and reinstalled once the roof is complete.

What type of products does Brightwell use?

Brightwell focuses on top tier products that have the industries longest warranties to ensure our projects last for decades.

Tier 1 Designation. The bankable Tier 1 ranking is a classification system signifies a company is considered highly reliable and has a strong financial standing, making it more likely for banks to provide loans for projects using their panels. Ratings of solar companies as top-tier solar panel producers based on their financial strength and production capacity.

Industry Leading Warranties. The solar panels, inverters, and racking systems have best-in-class 25-year product warranties and 30-year panel performance warranties.