

June 18, 2015

Irving PTO
1125 S. Cuyler Ave
Oak Park IL 60304

Oak Park District 97 Board of Education
District 97 Administration Building
970 Madison Street
Oak Park, IL 60302

Dear Board Members,

Thank you for your support and investment in the education of all D97 students. The Irving PTO would like to make a donation of two in-ground poles and hoops for the outdoor area of Irving Elementary School. These hoops will be installed on our blacktop. We are donating the rims, posts, backboards, post pads as well as the labor for the installation.

We have chosen to buy the basketball hoops from Haldeman-Homme. They have given us a quote for \$7570. We are attaching their proposal.

We believe that the addition of two basketball hoops will provide more active options on our playground for students. These hoops will be installed at two heights (8 ft and 10 ft) to accommodate our range in student ages and sizes. The rims will be removable and will be put up and taken down daily. The poles will be covered in pole pads to help minimize injuries.

We hope to install the hoops during the summer of 2015. Please let us know if you have any questions.

Thank you,
Irving PTO
Hannah O'Connor and Jeff Wallich
PTO Co-Presidents



John Hodge <jhodge@op97.org>

Fwd: Question on labor

1 message

Hannah O'Connor <hanoconnor@gmail.com>

Mon, Jun 22, 2015 at 8:53 AM

To: John Hodge <jhodge@op97.org>

Hey John,

Here is the short answer from Joe Massaro. He had told me when he was putting the quote together that they use union contractors. You can let Dr Roberts know that this is the same company that is installing all the new indoor hoops for the district and that they work for D200 as well. Let me know if you need anymore info.
Hannah

Begin forwarded message:

From: Joe Massaro <jmassaro@HALDEMANHOMME.com>
Date: June 22, 2015 at 8:06:36 AM CDT
To: Hannah o'connor <hanoconnor@gmail.com>
Cc: Joe Massaro <jmassaro@HALDEMANHOMME.com>
Subject: Re: Question on labor

Yes it's prevailing wage....

Sent from my Verizon Wireless 4G LTE DROID

Hannah o'connor <hanoconnor@gmail.com> wrote:

Hi Joe

Our superintendent for the district wants to know if the quote for labor is at the "prevailing wage?"
Could you please let me know so that we can have them approve this proposal. Thanks
Hannah

This email has been scanned by the Symantec Email Security.cloud service.
For more information please visit <http://www.symanteccloud.com>

Information contained in this email transmission from Haldeman-Homme is privileged and confidential. If you are not the intended recipient, do not read, distribute, or reproduce this transmission. If you have received this email transmission in error, please delete it and/or call 612-331-4880.

This email has been scanned by the Symantec Email Security.cloud service.
For more information please visit <http://www.symanteccloud.com>



HALDEMAN – HOMME, INC.

SERVING EDUCATION, HEALTH CARE, AND INDUSTRY SINCE 1924

SERVICES

- Layout & Design
- Project Management
- Construction
- Consulting / Training

PRODUCTS

- Porter Athletic Equipment
- Action Athletic & Wood Flooring
- Traction Athletic Flooring
- List Lockers
- Irwin Auditorium Seating

OFFICES

Chicago
445 Eisenhower Ln S.
Lombard, IL 60148

Tel: 630-812-0020
Fax: 630-812-0018

Minneapolis
430 Industrial Blvd.
Minneapolis, MN
55413

Tel: 612-331-4880
Fax: 612-378-2236

TO: Hannah O'Connor
Afn:
Summer work

Estimator Date: June 3, 2015
Project: Oak Park Schools / Irving PTO

Location: Oak Park, IL
Architect:
Addendum:

Bid Date:6-3-15

We propose to furnish the following as manufactured by Porter Athletic using standard design, materials, construction sizes and colors.

Outdoor Basketball Equipment

Quantity Two (2) Porter 5'-0" extension Gooseneck Outdoor Basketball Backstops with 4-1/2" Dia. mast as
With Rectangular Fiberglass backboards 42" x 72"
Super goal with net
Includes removable goal option

Total furnished only furnished only\$2,755.000

ADD \$465.00 for Safety pole pads" Color:Give

ADD \$4,350 for installation includes all concrete and forms etc.....One Goal can be mounted at 8'-0" high and one at 10'-0" high....

Excludes:

1. State Sales & Use Taxes. Purchaser by acceptance of this quotation agrees to furnish Tax Exemption Certificates when requested on non-taxable materials.
2. Charges for vertical transportation, Mechanical utilities and connections, Electrical utilities and connections, Bonds, Removal of existing equipment, Traps, Ducts, Fume hood fan/blowers, Rubber/vinyl base, Liquidated damages. Note: Clean-up to be limited to removing all debris, dirt and rubbish accumulated as a result of our installation to a dumpster provided by others, leaving the premises broom clean and orderly.
3. 50% Down payment is required for new customers and or private facilities

SEE & SIGN PAGE 2 for Terms & Conditions

This proposal is based upon usage of the AGC/ASA/ASC "Standard Form Construction Subcontract", 1996 Edition or a subcontract form otherwise acceptable to Haldeman-Homme, Inc.

TERMS: Net 30 Days

ACCEPTED: Company _____

RESPECTFULLY,

Name _____

HALDEMAN-HOMME, INC.

Date _____

By _____

Joe Massaro / Product Specialist





HALDEMAN – HOMME, INC.

SERVING EDUCATION, HEALTH CARE, AND INDUSTRY SINCE 1924

SERVICES

- Layout & Design
- Project Management
- Construction
- Consulting / Training

PRODUCTS

- Porter Athletic Equipment
- Action Athletic & Wood Flooring
- Traction Athletic Flooring
- List Lockers
- Irwin Auditorium Seating

OFFICES

Chicago
445 Eisenhower Ln S.
Lombard, IL 60148

Tel: 630-812-0020
Fax: 630-812-0018

Minneapolis
430 Industrial Blvd.
Minneapolis, MN
55413

Tel: 612-331-4880
Fax: 612-378-2236

Note: This quotation is offered for acceptance within 30 days and is subject to revision beyond that time.

TERMS AND CONDITIONS

General

These terms and conditions are a component part of the attached proposal and constitute the entire agreement between Haldeman-Homme, Inc. and any of its subsidiaries. By signing the proposal, Customer acknowledges that they understand and accept the proposal and the following terms and conditions. All work shall be done in accordance with the attached proposal unless otherwise provided for in writing and signed by Haldeman-Homme, Inc. Applicable sales, excise and use taxes are not included unless otherwise stated in the proposal. Tax exempt entities hereby agree to furnish tax exemption certificates when requested on non-taxable materials. Material Only Contracts: Responsibility for the unloading, handling, storage and installation of material transfers to the Customer upon shipment from the factory. Customer is responsible for receiving, unloading and inspecting materials and filing freight claim for any shortage or damage of materials. Delivery and freight charges are not included unless otherwise stated in the proposal.

Site Conditions

A smooth, level and clean sub-floor shall be provided or as required by Haldeman-Homme, Inc. Maintain environment at proper temperature (55-80 degrees F.) and humidity (35-50%) before, during and 30 days following installation. Delays due to circumstances beyond the control of Haldeman-Homme, Inc. shall entitle Haldeman-Homme, Inc. to an equitable adjustment of time and contract price.

Acceptance

This proposal may be accepted within 30 days subject to credit approval. Haldeman-Homme, Inc. reserves the right to revoke this offer prior to acceptance by customer.

Installation

This proposal assumes unloading and elevator use shall be conducted during normal business hours. This proposal is based on completing the work during normal business hours. Overtime, evening and weekend work is available at additional charge. Customer agrees to provide Haldeman-Homme, Inc. with sufficient and timely unloading facilities, dock and elevator access as needed at no additional cost to Haldeman-Homme, Inc. Customer shall provide temporary, secure storage for materials prior to installation. Customer shall provide adequate electrical power, lighting, water and restroom facilities during installation. Customer shall provide area that is free and clear and prepared for installation.

Engineering

All engineering, proposal drawings, specifications shall represent Haldeman-Homme, Inc.'s investment in engineering skill and development and remain the property of Haldeman-Homme, Inc.. Such are submitted with the understanding that the information will not be disclosed or used in any way detrimental to Haldeman-Homme, Inc.'s interests.

Changes

Any requests for changes to the scope of work shall be made in writing with signed acceptance by authorized personnel from Haldeman-Homme, Inc. and Customer.

Liability

Haldeman-Homme, Inc. shall not be liable for damages in any form or any other claim arising out of strikes, floods, fire, accidents, or any other causes beyond our control. Haldeman-Homme, Inc. shall not be liable for liquidated, consequential or any other damages or penalties of any kind for delays in completion of work. Haldeman-Homme, Inc. indemnity obligations to the Customer and owner are limited to the liability created by the gross negligence of Haldeman-Homme, Inc., its employees or subcontractors. In the event the terms of this agreement conflicts with the Customer's proposal or purchase order the parties acknowledge and agree the terms of this agreement shall control.

Payment

Payment in full will be due and payable thirty (30) days from invoice date. Customer agrees to pay progress-billing invoices during the course of the project reflecting partial shipment of material and/or partial completion of labor work performed. Where materials are stored or staged temporarily at the job site or in offsite or bonded warehouse, customer shall pay for materials and reasonable storage charges. The failure of the Customer to make payments within contract terms shall entitle Haldeman-Homme, Inc., in addition to all other rights, to suspend all work and shipments and shall further entitle Haldeman-Homme, Inc. to an extension of time of performance of the work. No payments shall be withheld from or penalties assessed against Haldeman-Homme, Inc. due to causes for which Haldeman-Homme, Inc. is not responsible.

Customer agrees that, if the billed amount is not paid within terms, a service charge will be charged on the overdue balance at a percentage rate of 1.5% (18% ANNUAL PERCENTAGE RATE) for all accounts. If the customer fails to pay the entire unpaid balance on the account when due Haldeman-Homme, Inc. may without further notice or demand, exercise all rights and remedies available by law for the collection of the balance due on the account. Haldeman-Homme, Inc. reserves the option to exercise its lien rights at all times in accordance with applicable law to secure collection of amounts due. Applicant will be liable for all expenses of collection with or without suit, including all court costs and reasonable attorney's fees to the extent under applicable state law. Venue shall be the State District Court of Minnesota.

Disputes

Customer and Haldeman-Homme, Inc. hereby agree that disputes between the parties which cannot be settled amicably, shall be settled through the State District Court of Minnesota.

Cancellation

An officer of Haldeman-Homme, Inc. must approve cancellation requests in writing. In order to compensate Haldeman-Homme, Inc. for its investment in engineering, time, processing and administrative work, approved cancellations shall be subject to cancellation charge of 25% of the contract amount plus the cost of materials produced or in production, labor or other services performed, freight, taxes and any other out of pocket expenses incurred by Haldeman-Homme, Inc.

Warranty





HALDEMAN – HOMME, INC.

SERVING EDUCATION, HEALTH CARE, AND INDUSTRY SINCE 1924

SERVICES

- Layout & Design
- Project Management
- Construction
- Consulting / Training

PRODUCTS

- Porter Athletic Equipment
- Action Athletic & Wood Flooring
- Traction Athletic Flooring
- List Lockers
- Irwin Auditorium Seating

OFFICES

Chicago
445 Eisenhower Ln S.
Lombard, IL 60148

Tel: 630-812-0020
Fax: 630-812-0018

Minneapolis
430 Industrial Blvd.
Minneapolis, MN
55413

Tel: 612-331-4880
Fax: 612-378-2236

THE MANUFACTURER EXPRESS WARRANTY IS PROVIDED IN LIEU OF ALL OTHER WARRANTIES, EXPRESS OR IMPLIED. THE WARRANTIES OF MERCHANTABILITY AND FITNESS FOR A PARTICULAR PURPOSE ARE HEREBY DISCLAIMED BY HH/HAL.

Insurance

Haldeman-Homme, Inc. maintains insurance and will provide certificates of insurance if requested on coverage and limits as provided by its insurance policy. No other insurance coverage is provided including waiver of subrogation or additional named insureds.

Codes

Customer, architect and/or contractor shall be responsible for all local, state and federal agency code compliance, permits, fees, design, engineering and testing. Haldeman-Homme, Inc. does not provide professional liability insurance for any of these services. Costs for any and all such services are not included in this proposal.

Signature _____



01216-000 - REMOVABLE GOAL KIT

REMOVABLE GOAL KIT WITH PADLOCK FOR 5" x 5" HOLE PATTERN

PORTER

WWW.PORTERATHLETIC.COM/FACILITY

BASKETBALL SPECIFICATION SHEET

B-1216

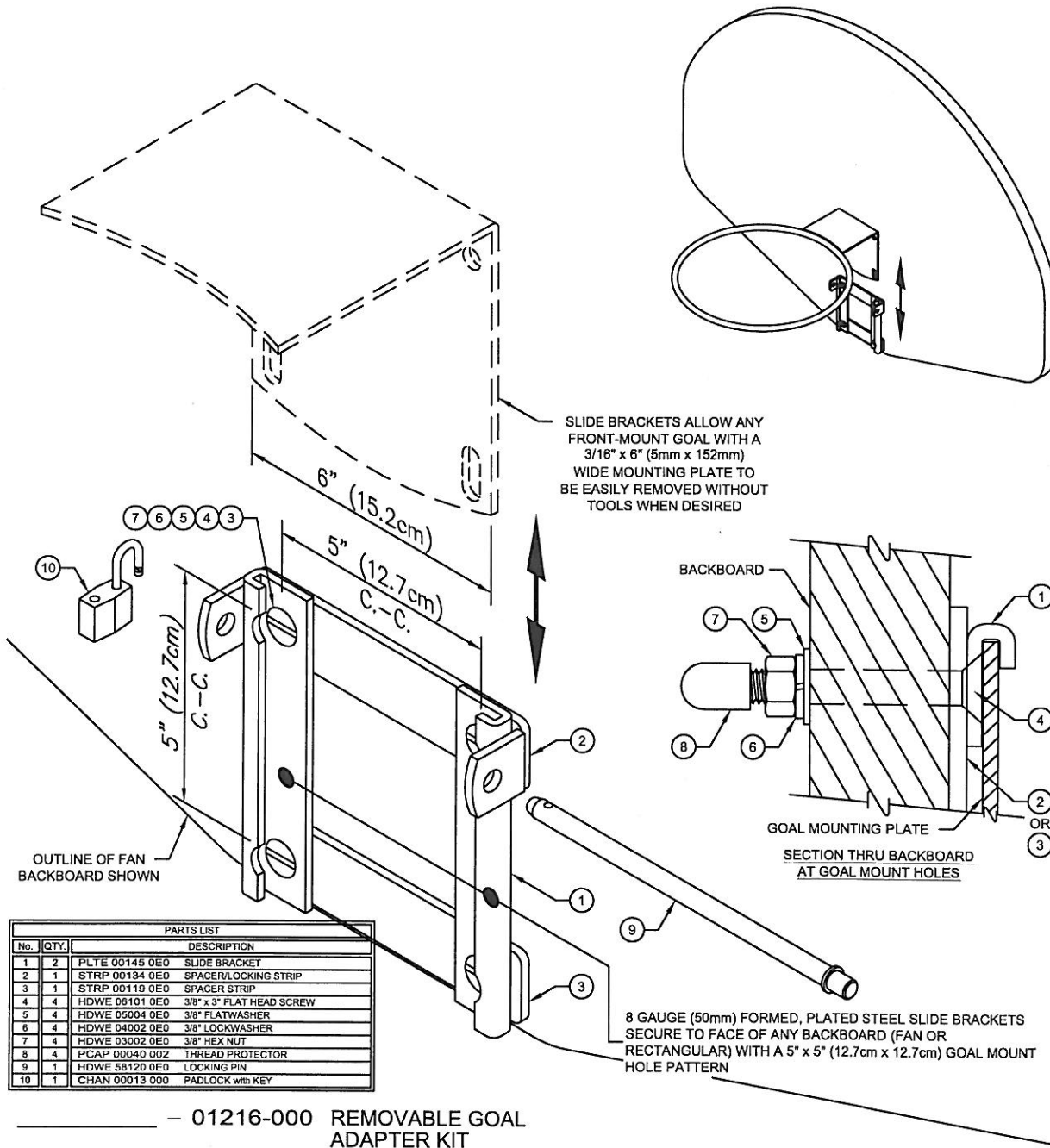

— 01216-000 REMOVABLE GOAL ADAPTER KIT

See B-201 — 00201-H00 STANDARD FRONT-MOUNT GOAL

See B-202 — 00102-H00 DOUBLE-RIM GOAL - ZINC PLATED

See B-202 — 00202-H00 DOUBLE-RIM GOAL - POWDER-COAT ORANGE

See B-235 — 00135-H00 HIGH-STRENGTH GOAL - ZINC PLATED

See B-235 — 00235-000 HIGH-STRENGTH GOAL - POWDER-COAT ORANGE

porter[®]

888-277-7778 PORTER@PORTERATHLETIC.COM
© COPYRIGHT 2014 PORTER ATHLETIC - ALL RIGHTS RESERVED

PROJECT NUMBER _____

PROJECT NAME _____

6/16/2014

01216-000 - REMOVABLE GOAL KIT

REMOVABLE GOAL KIT WITH PADLOCK FOR 5" x 5" HOLE PATTERN

SPECIFICATIONS

PORTER No. 01216-000 REMOVABLE GOAL MOUNTING KIT WITH PADLOCK

Kit shall allow instant removal of a standard front mount goal (5" x 5") bolt hole pattern with a 6" wide mounting plate). Kit provided with special locking pin and padlock to prevent unauthorized use or theft.

Kit consists of two (2), 8 gauge (50mm) formed, plated steel slide brackets which are secured to the face of the backboard. Slide brackets are shaped to hold goal in playing position and allow vertical removal of the goal when desired without the use of any tools. Spacer bracket shall be provided with two welded lugs to accept locking pin to prevent removal of goal.

All hardware shall be furnished with a plated finish for durability.

(Kit designed for use with Porter No. 00201-H00, 00102-H00, 00202-H00, 00135-H00 or 00235-000 goals, and any backboard with a 5" x 5" goal mounting hole pattern. Goal must have a 6" wide x 3/16" maximum thickness mounting plate.)

PORTER
WWW.PORTERATHLETIC.COM/FACILITY

BASKETBALL SPECIFICATION SHEET

B-1216

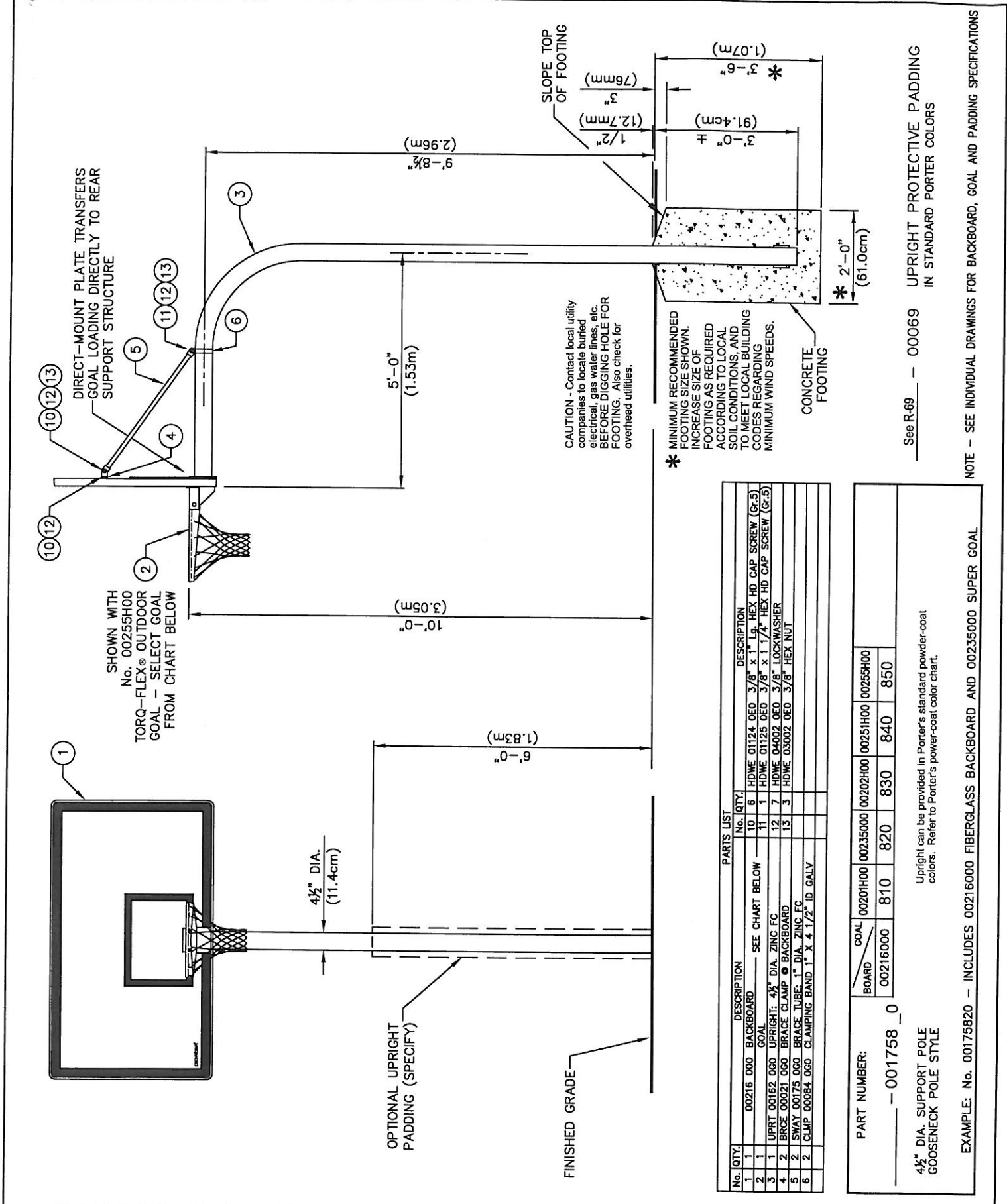

© COPYRIGHT 2010 PORTER ATHLETIC INC. ALL RIGHTS RESERVED

THIS PRINT IS THE PROPERTY OF PORTER ATHLETIC INC. AND MAY NOT BE REPRODUCED WITHOUT WRITTEN PERMISSION

00175-8

5' EXTENDED OUTDOOR BACKSTOP FOR RECTANGULAR FIBERGLASS BACKBOARD

porter

WORLD LEADER
IN QUALITY SPORTS EQUIPMENT

601 MERCURY DRIVE
CHAMPAIGN, ILLINOIS 61822
www.porterathletic.com

PAGE No. **R-175-8**

DATE **10/14/2010**

No. QTY.	DESCRIPTION	No. QTY.	DESCRIPTION
1	00216 000 BACKBOARD	10	6 HDWE 01124 0EO 3/8" x 1" Lg. HEX HD CAP SCREW (Gr.5)
2	GOAL	11	1 HDWE 01125 0EO 3/8" x 1 1/4" HEX HD CAP SCREW (Gr.5)
3	UPRT 00162 0G0 UPRIGHT: 4 1/2" DIA. ZINC FC	12	7 HDWE 04002 0EO 3/8" LOCKWASHER
4	BRCE 00021 0G0 BRACE CLAMP: 3/8" BACKBOARD	13	3 HDWE 03002 0EO 3/8" HEX NUT
5	SWAY 00175 0G0 BRACE TUBE: 1" DIA. ZINC FC		
6	CLMP 00084 0G0 CLAMPING BAND: 1" x 4 1/2" ID GALV		

PART NUMBER:	BOARD	GOAL	00201H00	00235000	00202H00	00251H00	00255H00
001758_0	00216000	810	820	830	840	850	

Upright can be provided in Porter's standard powder-coat colors. Refer to Porter's power-coat color chart.

EXAMPLE: No. 00175820 - INCLUDES 00216000 FIBERGLASS BACKBOARD AND 00235000 SUPER GOAL

See R-99 - 00069 UPRIGHT PROTECTIVE PADDING IN STANDARD PORTER COLORS

NOTE - SEE INDIVIDUAL DRAWINGS FOR BACKBOARD, GOAL AND PADDING SPECIFICATIONS

SPECIFICATIONS

PORTER No. 001758X0 – 5' EXTENDED SINGLE POST BACKSTOP WITH RECTANGULAR FIBERGLASS BACKBOARD AND GOAL

Face of backboard shall be 5'-0" (1.53m) extended from the centerline of the formed upright support. Upright support shall be 4-1/2" (11.4cm) O.D., 7ga. wall (0.180", 4.57mm), zinc Flo-Coated steel tube, formed to an approximate 24" (61.0cm) radius. Vertical section shall extend 3'-0" (91.4cm) into a concrete footing and shall be secured by welded anchor lugs. Horizontal section shall be fabricated with a special, slotted mounting plate to level the backboard and goal. Bolts from the front mounted goal shall mount directly through the backboard and into the Center-Strut® mounting plate to eliminate any strain on the backboard should a player hang on the front mounted goal.

Backboard shall be supported by two, 1" (2.54mm) O.D., 14ga wall, steel sway braces that terminate on the horizontal support tube approximately 32" behind the backboard. Diagonal sway brace tubes shall be secured to the horizontal support tube by means of a heavy steel clamping band, which is adjustable to plumb backboard. Sway brace tubes have a zinc Flo-coat finish.

X designates goal required – see chart on opposite side of this sheet for selection – specify. For specifications of backboard and optional goals, see specific page in backboard/goal section.

Upright and brace tubes can be provided in Porter's standard powder-coat colors. Refer to Porter's powder-coat color chart.

OPTIONAL ITEMS TO SPECIFY

- See Page No. B-324-72 for specifications on Porter No. 00324672 Backboard Padding (Each).
- See Page No. R-69 for specifications on Porter No. 00069 Upright Padding (Each).