



Lead & Radon Updates

SITUATION

Testing for Lead in Drinking Water: The Beaverton School District contracted with PBS Engineering + Environmental to conduct District-wide water testing in all schools and buildings this summer. More than 6,000 samples were collected and sent to the lab for testing. We have begun to receive results and are taking action to address drinking water fixtures that registered a test result of 15 parts per billion (ppb) or higher. We are finding relatively few fixtures need to be replaced.

Background:

An interdepartmental Water Quality Team meets weekly to review the latest test results and plan appropriate interventions.

- See attached *District Water Sampling & Testing Status Report dated August 18, 2016.*
- See draft parent letter for principals to report out to their school community.

Here are the steps the District has taken:

- Turn off water outlets that have a 15 ppb or higher result.
- Replace fixtures that have results of 15 ppb or higher. We hope to complete this work by the start of school in September.
- Conduct follow up testing on these outlets and the new fixtures. The water will remain off until the retest results are received and fall below the 15 ppb threshold.
- Communicate test results on a weekly basis to staff, parents and community.
- Established a [Water Quality webpage](#).

Radon Testing: The Beaverton School District conducted targeted radon sample testing in all schools and facilities last winter and spring. The results revealed no elevated radon above the EPA Action Level of 4.0 pCi/L at any school or facility with the exception of three rooms at Ridgewood Elementary School. The District retested Ridgewood and all levels fell below the EPA Action Level. Additional steps were taken to adjust the ventilation and pressurization systems at Ridgewood. Longer term testing will occur in the fall and winter months. Ridgewood received HVAC improvements this summer as part of the 2014 bond program.

- See attached *Radon Test Report*

Background:

Beaverton School District last tested schools for radon in 2001 and 1989. In July 2015, the District hired an industrial hygiene consultant, AMEC Foster-Wheeler, to review the current Beaverton SD Radon Program and outline a strategy to best implement targeted radon testing at all Beaverton schools and support facilities. Based upon the consultant's recommendations, District-wide targeted radon sampling began in January 2016.

The Beaverton School District is committed to sampling all schools and facilities for radon over the next several years and already aligns with new radon legislation. Oregon Revised Statute (ORS) 332.166-167, mandates testing in every occupied room in schools/facilities by 2021. The first round of testing covered some rooms in every school and facility. All occupied rooms will be tested by 2021.

District Goal: WE empower all students to achieve post-high school success.

The Beaverton School District recognizes the diversity and worth of all individuals and groups. It is the policy of the Beaverton School District that there will be no discrimination or harassment of individuals or groups based on race, color, religion, gender, sexual orientation, gender identity, gender expression, national origin, marital status, age, veterans' status, genetic information or disability in any educational programs, activities or employment.

New State Requirements: Healthy and Safe Schools Plan

The Oregon State Board of Education has adopted a new OAR requiring districts to create a Healthy and Safe Schools Plan by January 1, 2017, to update it annually, and by October 1, 2016 provide a report to the School Board and submit a preliminary draft of the Plan to ODE. The OAR contains many ambitious requirements that will require early and swift actions by school districts in order to comply.

Key OAR 581-022-2223 Requirements for the Plan:

- Appoint a responsible person for maintaining and implementing the Plan
- Testing for elevated levels of radon
- Testing for, and reduce exposure, to lead in water used for drinking or food preparation
- Improve indoor air quality
- A plan to reduce exposure to lead paint
- A plan to implement integrated pest management practices
- A plan to communicate results for all tests required under the Healthy and Safe Schools Plan that includes making test results available to the public within five business days of receiving results, make test results available to the public by posting the results on the district website, sending notice of the results over the email system, and making the results available in hardcopy at the main admin building
- The District must provide detailed information explaining the test results
- Annual certification that the Plan is up to date and required testing has been completed

The District is in the process of determining the resources we will need to comply with these new requirements. An interdepartmental team is advising the process.

Resources: www.oregonhealth.org/healthyschools



District Water Sampling & Testing Status



Engineering +
Environmental

As of: Thursday, August 18, 2016

SCHOOL	Locations	Samples	≥15 ppb <20 ppb	≥ 20 ppb (EPA Action Level)	Result Notes	Results on File	Action Taken	Retesting Results
MAINT/CUSTODIAL	8	16	0	1	Samples ranged from none detected to 46.3 ppb for lead.	X	Water fountain shut off. Scheduling faucet replacement. Building and domestic water system scheduled for upgrades in Summer of 2017.	
MAIL ROOM								
SPECIAL ED - ALOHA OFFICE	2	4	0	1	Samples ranged from 0.344 to 31.6 ppb for lead, no copper samples above action level.	X	Water fountain shut off. Scheduling faucet replacement.	
SPECIAL ED - AUTISM ANNEX								
TRANSPORTATION 5TH ST. NORTH	3	6	0	0	Samples ranged from 2.31 to 9.43 ppb for lead, no samples above action level.	X	No further action planned.	
TRANSPORTATION 5TH ST. SOUTH	1	2	0	0	Samples ranged from 0.344 to 2.22 ppb for lead, no samples above action level	X	No further action planned.	
TRANSPORTATION ALLEN CENTER								
TRANSPORTATION SUPPORT CENTER	11	22	0	1	Samples ranged from none detected to 46.5 ppb for lead.	X	Water fountain shut off. Scheduling faucet replacement.	

School letterhead

Date

Dear **(School Name)** families,

As you know, the Beaverton School District tested all schools and support facilities for lead in the drinking water in June and July 2016. In all, over 6,000 samples were taken.

Here are the results for our school:

(We recommend that you enter sample results once your school is listed as complete.)

example:

There were **XX** of drinking fixtures tested with two samples drawn from each. We had **XX** of drinking faucets that tested 15 parts per billion (ppb) or higher.

Here are the steps we are taking:

- The District will turn off drinking faucets that have a 15 ppb or higher result.
- We will replace fixtures that have results of 15 ppb or higher. We hope to complete this work by the start of school in September.
- We will conduct follow up testing on these new fixtures. These fixtures will remain off and out of service until the retest results are analyzed and determined to be under the 15 ppb action level.

The District has established a [webpage](#) to keep the community informed. We will provide test results and ongoing updates as the process unfolds.

Where can I get more information?

Lead line: leadline@multco.us

503-988-4000

Please let me know if you have additional questions. Thank you!

Sincerely,

Principal

2016

Radon Program

Beaverton School District

Contents

1.0	INTRODUCTION	2
2.0	BSD RADON BACKGROUND	3
2.1	1989 RADON SAMPLING	3
2.2	2001 RADON SAMPLING	3
2.3	2014 RADON PROGRAM DEVELOPMENT	4
2.4	2015-2016 RADON SAMPLING	5
2.5	2016 RADON TRAINING	6
2.6	OREGON RADON LEGISLATION.....	6
3.0	BSD CURRENT SAMPLING STRATEGY.....	7
3.1	5-YR SAMPLING STRATEGY OVERVIEW.....	7
3.2	RADON TRAINING PROGRAM.....	9
4.0	BSD SAMPLING PLAN OVERVIEW.....	10
5.0	BSD SAMPLING PROCEDURES.....	12
5.1	GENERAL SAMPLING RULES	12
5.2	SAMPLE PLACEMENT AND DURATION.....	13
5.3	QUALITY ASSURANCE/ CONTROL	14
5.4	RESAMPLING PROCEDURES.....	15
6.0	MITIGATION.....	17
7.0	RADON REPORTING AND DISTRIBUTION	17

Attachments

Attachment 1: Table 1 – Radon Sampling for New Sites since 1989

Table 2 – Radon Sampling for Sites with Prior Elevated Radon Results

Table 3 – Radon Sampling for Sites with No Prior Elevated Radon Results

Attachment 2: Radon Test Placement Protocol Checklist and Communication Memo

Attachment 3: BSD Radon Sample Spreadsheet

Attachment 4: BSD Radon Training Powerpoint

Appendices

Appendix A: Oregon Legislature HB 2931 and Oregon Revised Statute (ORS) 332.166-167

Appendix B: Oregon Health Authority ‘*Protocol for Elevated Radon in Schools*’ document

Beaverton School District Radon Program

1.0 INTRODUCTION

The Beaverton School District (BSD) is committed to identifying radon and minimizing its risk district-wide. Radon is a natural gas emitted from natural deposits of uranium in soil, which can move up through the soil allowing it to enter buildings in contact with the soil. Any building has the potential for elevated levels of radon and the only way to determine this level is to test the building.

In 2014, BSD embarked on the development of a comprehensive site-specific radon program that outlined a limited targeted radon sampling approach for all district schools and support facilities. The focus of this plan was to develop site-specific radon planning and training, detail a sample strategy and procedures, ensure result accuracy, outline communication channels, and provide a comprehensive sample result database.

The current version of the program herein has now been updated to incorporate recent 2016 targeted radon sample results and integrate new regulatory radon requirements. The primary objectives in this radon plan include a detailed approach to:

1. Conducting radon sampling in all schools and support facilities in all frequently occupied spaces in contact with the soil or located above a basement or a crawlspace.
2. Completing sampling of all required spaces throughout the District by January 1, 2021, and
3. Reporting results to the BSD community and the Oregon Health Authority.

To date BSD has collected 1350 samples at schools and support facilities throughout the District.

BSD is confident that this comprehensive radon program will deliver statistically reliable radon results with the most efficient sample effort to minimize the risk of radon and provide effective communication to the students, teachers, staff and community on radon levels district-wide.

2.0 BSD RADON BACKGROUND

BSD has radon sample results dating back to 1989 but more sampling was warranted. As such, in 2014 BSD embarked on the development of a comprehensive site-specific radon program that outlined a limited targeted radon sampling approach at all facilities which began in the winter of 2016. The current version of the program herein has now been updated to incorporate findings of the most recent targeted radon sample results and integrate new regulatory radon requirements.

To date BSD has collected 1350 samples at schools and support facilities throughout the District.

2.1 1989 RADON SAMPLING

BSD conducted a majority of our radon sampling in-house in 1989. A total of 932 short-term radon samples were collected within the District at that time. The Central Administration Office and Maintenance building were also sampled. Other support facilities were not. A total of 36 initial samples reported values over the U.S. Environmental Protection Agency (EPA) Action Level of 4.0 picocuries per liter of air (pCi/L). All 36 samples were retested and only three (3) samples were confirmed to contain radon concentrations over 4.0 pCi/L. Finally, those three (3) samples were retested a second time. Those retested high samples were reported from the following schools:

1. Aloha HS, classroom J-1 – retest = 4.5 pCi/L. Retest 2 = 4.8 pCi/L,
2. Errol Hassell ES, classroom 312 – retest = 4.4 pCi/L. Retest 2 = 7.4 pCi/L,
3. Greenway ES, classroom 28 – retest = 6.2 pCi/L. No 2nd retest conducted.

2.2 2001 RADON SAMPLING

In 2001, limited follow-up sampling was conducted by ATC associates. Resampling was conducted at the three schools above, Aloha HS, Errol Hassell ES, and Greenway ES, as well as additional sampling at 10% of remaining schools. Four schools (10%) were randomly selected and consisted of Beaverton HS, Montclair ES, Mountain View MS, and Ridgewood ES. A total of 54 samples were collected during this period. The resampling conducted of the 3 prior schools and new sampling conducted of the 4 additional schools showed non-detect radon concentrations with the exception of the following:

1. Beaverton HS, conference 3 – test 1 = 5.2 pCi/L. Retest = 1.6 pCi/L (2.3 pCi/L duplicate)
2. Errol Hassell ES, class M-10 – test 1 = **4.7 pCi/L**. Retest = **4.7 pCi/L (5.1 pCi/L duplicate)**
3. Montclair ES, class M-100– test 1= 4.3 pCi/L. Retest = 1.6 pCi/L (1.9 pCi/L duplicate)

An evaluation was conducted at classroom M-10 at Errol Hassel - the only confirmed high sample from 2001 sampling. It was determined that a crawlspace fan was negatively pressurizing the classroom space. The issue was corrected and the area was retested and determined to be below the 4.0 pCi/L EPA Action Level:

1. Errol Hassell ES, class M-10– retest after engineering control = 0.2 and 0.8 pCi/L.

At the conclusion the 2001 sampling, no resampled areas contained radon concentrations over the 4.0 pCi/L EPA Action Level.

2.3 2014 RADON PROGRAM DEVELOPMENT

In 2014, BSD's radon consultant, AMEC Foster-Wheeler (AMEC), conducted a thorough review of the District's existing legacy sample data. AMEC worked with the District to develop a comprehensive radon program. Analyzing the initial radon sample data, the following data gaps were identified:

1. New sites built or acquired since 1989 have no radon sample data.
2. New schools additions completed after 1989 have no radon sample data.
3. Schools with detectable radon results should be resampled to verify non-detect status.
4. Sites with non-detectable radon results should be resampled to verify original sample results.

The above findings shaped a sampling strategy for the new district radon program. Program development also included a new radon database spreadsheet to organize the data set and allow for filtering functionality. The spreadsheet included the site name and type, area and date of sample, and all test and resample results and was designed to be expandable to accommodate new sample data. The spreadsheet may be found as Attachment 3 to this document.

Considering the existing data and current data gaps, AMEC along with BSD stakeholders agreed that the radon program would follow a targeted sample approach to fill radon data gaps. A prioritized targeted sample strategy would be the most effective way to quickly gather meaningful and current radon data throughout the District. The current listing of District sites were sorted and prioritized into four (4) prioritized categories, which included:

1. Sample all new District sites and areas not previously sampled. This includes newly built or newly acquired sites. This also includes additional square footage area resulting from significant renovation projects since 1989.
2. Re-sample all areas with any prior results *over* 4 pico curies per liter (pCi/L) and re-sample a percentage of areas with any prior results *less than* 4 pCi/L.
3. Re-sample all areas, with long-term testing where appropriate, with any new radon concentration results over 4 pCi/L.
4. Re-sample remaining schools previously sampled and reported to no measurable radon levels. This would also include resampling of site areas that undergo significant renovation.

For each of these four (4) categories, a table was developed listing applicable sights and a minimum range of recommended representative samples were to be collected for each site based on square footage. Minimum recommended samples would range from 6-20 samples.

2.4 2015-2016 RADON SAMPLING

Following this newly developed radon sampling program plan, AMEC began district-wide targeted short-term radon sampling on in January 2016 and continued targeted sampling through May 2016.

Targeted sampling was conducted at every school and support facility. 423 short-term samples were collected district-wide. Sample distribution averaged six (6) samples per elementary school, 10 samples per middle school, and 12 samples per high school. Support facilities averaged 6 samples collected.

The initial targeted radon sampling determined that only Ridgewood Elementary School (ES) exceeded the U.S. EPA Action Level of 4.0 pi/C. All other district schools and facilities sampled were below Action Level.

Initial testing conducted on March 15, 2016 at Ridgewood ES consisted of six (6) samples. Of those the gym sample was found to be over the Action Level. A retest of the same six areas was conducted on April 4, 2016 and revealed gym radon levels below the Action Level and the 'C-Hall by classroom 114' was now well above the Action Level. Initial test and retest results that exceeded the Action Level included the following:

1. **Gym – Initial test = 5.8 pCi/L.** Retest = 1.7 pCi/L, and
2. **C-Hall by classroom 114 - Initial test = 2.9 pCi/L. Retest = 8.0 pCi/L.**

Due to the variability of the two sets of radon results, BSD's radon consultant collected another twenty (20) samples throughout the school including the 6 original sample locations. **In this 3rd round of sampling conducted on May 16, 2016, none of the 20 samples collected were above the Action Level.**

BSD's action plan for Ridgewood ES is to make adjustments to the schools HVAC ventilation system and improve ventilation where possible. BSD will also be working to ensure proper positive pressurization building-wide. After these adjustments have been made long term testing will be conducted at the school during the 2016-2017 school year.

2.5 2016 RADON TRAINING

As part of AMEC's radon scope of work, an initial radon awareness training to all District school custodians at the District's Annual All Hands Training on June 21, 2016. AMEC touched on what radon is, the entry routes of radon, when and where to sample and under what conditions, and how to sample for radon using short-term kits. The radon slide presentation is available to the district to assist in internal training of key sampling personnel and is provided as Attachment 4. BSD will provide necessary training to key personnel throughout all phases of the radon program.

2.6 OREGON RADON LEGISLATION

The Oregon Legislature passed HB 2931 in the Spring 2015 session which later became Oregon Revised Statute (ORS) 332.166-167. Copies of these documents are provided as Appendix A. BSD's radon program was initially developed to be flexible enough to accommodate this anticipated legislation.

Additionally, as directed under this statute, the Oregon Health Authority (OHA) has produced a guide to assist Oregon school districts to accurately measure their school buildings for elevated radon. The final document version 1.0 - 2016 entitled '*Protocol for Elevated Radon in Schools*' takes into account current national guidelines for measuring radon in schools and large building. It is based on radon school measurement plans from other states. This guidance document is also included as Appendix B.

The current radon program explains in detail how the District plans on complying with the new regulatory requirements in Section 3.0 below.

BSD will remain cognizant of any new radon laws and incorporate those requirements into our program on annual basis.

3.0 BSD CURRENT SAMPLING STRATEGY

BSD's current radon sampling strategy and plan integrates current radon sample data results through 2016, radon requirements under ORS 332.166-167, and the OHA radon sampling guidance document.

As such, BSD's primary program goals are as follows:

1. Continue to provide radon testing in all schools and support facilities in all frequently occupied rooms in contact with the ground or located above a basement or a crawlspace on or before January 1, 2021.
2. Radon testing results will be provided to the district school board and made readily available to parents, guardians, students, school employees, school volunteers, administrators and community representatives on the school district's website. Radon results will also be forwarded to OHA for posting on their website.
3. Provide radon testing in all schools and support facilities at least once every 10 years thereafter.

3.1 5-YR SAMPLING STRATEGY OVERVIEW

Now that targeted sample results are available for all BSD schools and facilities, the focus will shift on sampling schools and facilities in their entirety until all required interior spaces are sampled. Sample priority given for schools and support facilities will fall in to the following 3 categories largely based on known risk:

1. Task 1 - Re-sample Ridgewood elementary school based on 2015/2016 results. Sample District schools and support facilities that are **newly acquired or contain additional square footage** since 1989,
2. Task 2 - Sample District schools and support facilities with **any prior** results *near or over* 4 pico curies per liter (pCi/L), and
3. Task 3 - Sample remaining District sites where all results have been considerably less than 4 pCi/L or non-detect.

Tasks 4 will include sampling any remaining required spaces and/or resampling spaces where required. Task 5 will include conducting final radon program updates based on final sample results and finalizing any reporting requirements.

Note that if any site is found to have results over the EPA Action Level, the site will be resampled immediately within the same sample season (October – March). If long-term testing is required and it is late in the sample season, sampling may be scheduled for the beginning of the next sample year.

Three (3) tables have been developed detailing each of the first 3 tasks and are included as Attachment 1 to this program document. Table 1 below provides a summary of this sample effort, timing, and cost over the next 5 years.

TABLE 1 – BSD RADON SAMPLING PLAN OVERVIEW WITH ESTIMATED COSTS

Task	Task Description	Timing	Estimated Samples Collected(1)	Estimated Cost to the District(2)
Task 1	Table 1 - New schools and support facilities and sites with additions since 1989 - 21 sites. Task 1 includes additional sampling at Ridgewood ES.	October 2016 – March 2018	1250	\$19,500
Task 2	Table 2 – Schools and support facilities with any prior radon result near or over EPA Action Level – 25 sites.	October 2018 – March 2019	1500	\$22,500
Task 3	Table 3 - Schools and support facilities with all prior radon results under EPA Action Level – 8 sites.	October 2019 – March 2020	400	\$6,000
Task 4	Any remaining resampling throughout the District prior to January 2021 deadline.	October 2019 – March 2020	TBD	TBD
Task 5	Radon program updates and all final reporting requirements completed.	April 2020-December 2020	TBD	TBD
Total timeline and estimated total sample count based on required room sample count estimates				\$48,000
<p>(1) Sample count includes estimated occupied basement and first floor with contact with the ground and all rooms over a crawlspace including portable classrooms. Sample counts also include sample blanks, duplicates, and spike samples for QA/QC.</p> <p>(2) Sample costs based on a per sample cost of \$5.85 x sample count + estimated annual consultant fee.</p>				

3.2 RADON TRAINING PROGRAM

BSD will continue to provide appropriate radon training to key district personnel who will be responsible for conducting radon sampling. Radon sampling may only be conducted by BSD personnel who have received the appropriate level of radon training or under the supervision of the radon consultant or trained BSD staff member.

Primary objective will be to ensure valid sample collection throughout the District that meets recommendations outlined in the OHA guidance document. Training will include but not be limited to what radon is, the entry routes of radon, when and where to sample and under what conditions, and how to sample for radon using short-term kits. The radon training may be conducted internally or with the assistance of the radon consultant.

The radon training slide presentation is provided as Attachment 4.

4.0 BSD SAMPLING PLAN OVERVIEW

To execute the radon strategy outlined in Section 3.0, the following sampling plan has been developed:

1. The BSD Radon Program shall be administered by the BSD Maintenance Department with oversight from a qualified radon consultant.
2. Radon sampling will occur in all frequently occupied spaces in contact with the soil or located above a basement or a crawlspace and will occur simultaneously per site.
3. BSD will utilize internally trained staff to conduct radon sampling at each school and support facility throughout the District between the months of October and March each year.
4. BSD will purchase the radon sampling kits (www.airchek.com) and distribute the kits to the sample sites as necessary.
5. The radon consultant will be responsible for developing a detailed annual district-wide sampling plan that complies with the sample strategy defined in Section 3.0 above.
6. The radon consultant will be responsible for developing a site-specific sampling plan for each site that must be approved by BSD. The plan will include:
 - a. Room/ area listing with sample count per area,
 - b. A sample test kit placement log to record specific location, date, and time information,
 - c. Facility map indicating sample areas, and
 - d. Consultant contact information.
7. BSD will be responsible for providing a brief radon tutorial to the site administrator(s) prior to conducting the survey and sampling.
8. Trained BSD staff will conduct radon sampling procedures in accordance with Section 5.0 below and will utilize the '*Radon Test Placement Protocol Checklist*' provided as Attachment 2.
9. The radon consultant will also be responsible for sample pick up, initial sample info validation, and blank/duplicate/spike sample verification while on-site.

10. The radon consultant will be responsible for sample chain-of-custody completion, enter all sample information into the radon laboratory's sample analysis spreadsheet, and shipment of all radon samples to the accredited laboratory.
11. All sample results from the radon laboratory will be sent directly to the radon consultant for final sample data validation and enter all results into BSD's Radon Sample Spreadsheet (attached). The radon consultant will also be responsible for corresponding sample results to locations on each site's map.
12. The radon consultant will notify BSD of any radon results over the EPA Action Level within 24-hrs of sample result receipt from the laboratory.
13. Any sample results that are over the EPA Action Level will be re-sampled per Section 5.4. If results are verified over the EPA Action Level, engineering controls will be pursued to the extent possible prior to mitigation system discussion.
14. The radon consultant will prepare a detailed report on an annual basis that summarizes findings, conclusions, and recommendations.
15. BSD will be responsible for forwarding annual sample results to the OHA in the required format on an annual basis or at a frequency required by OHA.
16. The District along with the radon consultant will collectively review and update the radon plan minimally on an annual basis to ensure regulatory compliance is met and integrate any new radon legislation. Estimated radon budgeting projections will also be adjusted on an annual basis.

5.0 BSD SAMPLING PROCEDURES

Sampling methodology has been developed to comply with the OHA Radon Measurement Protocol for Oregon Schools 'Testing for Elevated Radon in Public Schools' guidance document included as Appendix B.

NOTE: Radon sampling may only be conducted by BSD personnel who have received the appropriate level of radon training or under the supervision of the radon consultant or trained BSD staff member.

5.1 GENERAL SAMPLING RULES

Radon sampling procedures shall include the following:

1. All schools and facilities should be notified well in advance of sampling at their facilities. Staff should be given the radon communication memo provided in Attachment 2 as well as a firm sample period date.
2. Radon sampling should not be conducted if the school or support facility is planning remodeling; making changes in the heating, ventilating and air conditioning system; or performing other modifications that may influence the radon concentration during the measurement period.
3. The sample area should be closed, with all windows and external doors shut (except for normal entrance and exit) for at least 12 hours prior to and during the sampling period. For this reason, measurements should be made during the winter whenever possible.
4. Sites shall only be tested for radon during periods when the HVAC system is operating as it does normally and during the time that students and teachers are normally present.
5. All radon samples should be collected in the colder/winter months – October 1- March 31.
6. Do not conduct short-term measurements (2-5 days) during severe storms or period of high winds.
7. Initial measurements should be short-term measurements of 2-7 days, and should be made in all frequently occupied rooms in contact with the soil, whether the contact is slab-on-grade, a basement, a room above a crawlspace or any combination.
8. All radon samples should be deployed in a school or facility on the same day.

9. The radon sample must not be disturbed during the measurement period.
10. Frequently occupied rooms include classrooms, offices, conference rooms, computer rooms, gymnasiums, auditoriums, cafeterias and break rooms.
11. Do not test storage rooms, kitchens, bathrooms, stairways, hallways, or elevator shafts.
12. A minimum of one detector test kit must be placed for up to every 2000 square feet of open floor area. For example, a 3500 square foot gymnasium would require two test kits.
13. In addition to the initial radon sample kits, the radon consultant will also supply the required Quality Assurance (QA) samples to be collected in accordance with Section 5.3.

5.2 SAMPLE PLACEMENT AND DURATION

Sample placement and duration procedures described here are summarized from the 'Radon Test Placement Protocol Checklist' provided as Attachment B.

1. Prior to opening the radon sample read all instructions that come with the specific radon sample kit and make sure all fields are properly filled out including but not limited to: (1) sample area, (2) sample time on, (3) sample serial number, (4) any relevant room conditions.
2. When collecting the radon sample be sure to note the sample stop time.
 - a. **The most important information is the day and time the sample was opened and the day and time the sample was closed.**
 - b. Be sure at end of sampling that the sample is securely closed.
3. Test kits should be placed:
 - a. Where they are least likely to be disturbed or covered up,
 - b. At least 3 feet from doors, windows to outside or ventilation ducts,
 - c. At least one foot from exterior walls,

- d. At least 20 inches to six feet from floor (as close to the breathing zone as possible), and,
 - e. About every 2,000 square feet for large spaces (e.g., a 3500 square foot gymnasium would require two test kits)
4. Test kits must **NOT** be placed:
- a. Near drafts resulting from heating, ventilating vents, air conditioning vents, fans, doors, and windows.
 - b. In direct sunlight
 - c. In areas of high humidity such as bathrooms, kitchens, laundry rooms, etc.
 - d. Where they may be disturbed at any time during the test.
5. The sample should be deployed for a 3 to 5 day measurement period – minimum 48 hrs and maximum 7 days. The sample period usually sampling will occur on Monday morning and conclude on Thursday morning.
6. When retrieving the radon sample, care should be taken to inspect the device for tampering during the sample period. Any sample device displaying any signs of tampering should be voided.
7. Confirm with Maintenance and the radon consultant for sample pick-up for lab shipping to occur the same day samples are collected.
8. The radon sample must be sent to the laboratory as soon as possible, preferably within a few days following exposure termination.

5.3 QUALITY ASSURANCE/ CONTROL

The following Quality Assurance/ Quality Control (QA/QC) parameters will be integrated into the radon sampling plan. The radon consultant will be responsible for including the required number duplicates, blank, and spike samples for each site. Each site should have a minimum of one duplicate and one blank.

1. **Duplicates:** Duplicates provide an indication of the precision of the measurement. Duplicates are test kits that are placed in the same location alongside the kits used as detectors for the same measurement period.

- a. The number of duplicates should be 10 percent of the rooms to be tested at each site.
 - b. A minimum of one duplicate per site is needed.
2. **Blanks:** Blanks can be used to determine whether the manufacturing, shipping, storage, or processing of the test kit has affected the accuracy of the measurements. They are called blanks because when placed alongside detectors, that are opened, but then immediately resealed. As a result, blanks should have results at or close to 0.0 pCi/L.
- a. The number of blanks should be 5 percent of the rooms to be tested at a school site. A minimum of one blank per building is needed.
3. **Spikes:** Spikes evaluate how accurately the detectors supplied by the laboratory measure radon and the accuracy of the lab's sample processing.
- a. The number of spikes should be 3 percent of the rooms to be tested at a school site.

The radon consultant will calculate how many detector kits are needed. This number equals the number of "regular" rooms that are to be measured plus those kits required for "larger" rooms (2000 sq. ft. or larger). [Larger rooms need one test kit per 2000 sq. ft. or portion thereof, so a 3500 sq. ft. gymnasium needs two detector kits.] Test kit percentages for QA are based on the number of rooms to be tested, NOT the number of detector kits to be used.

After determining the number of test kits (detectors, blanks, duplicates & spikes) needed for initial measurement of school site(s), kits should be purchased from one manufacturer (and be from one lot). It is most cost effective to purchase in bulk.

Once the kits are received, Team staff should randomly draw the kits needed for spiking (the 3%) from the boxes. The serial numbers of the kits should be recorded, noted as the kits being reserved for spike testing, and set aside.

5.4 RESAMPLING PROCEDURES

Areas to be resampled will ultimately be decided by the radon consultant after consultation with the District. Conditions that trigger resampling will generally include the following information.

If the results of a radon screening test in any frequently occupied room are found to be 4.0 pCi/L or greater, follow-up measurements should be conducted. EPA and OHA recommend that follow-up testing of rooms 4.0 pCi/L or greater be conducted before any mitigation decisions are made. Follow-up testing should start quickly, ideally within one month of receiving initial test results.

Based on the results of the initial short-term test for a room, the following steps should be conducted:

- If the result is less than 2.0 pCi/L, ORS 332.166-167 requires school districts to test again every ten years.
- If the result is between 2.0 pCi/L and 4.0 pCi/L, consider fixing (lowering) the radon in that room.
- If the result is from 4.0 pCi/L to 8.0 pCi/L, perform a follow-up measurement of that room using a Long-Term test. This should be conducted over as much of a nine-month school year as possible, when the room's likely to be occupied. If that result is equal to or greater than 4.0 pCi/L, the radon in the room should be fixed (lowered).
- If the initial test result is equal to or greater than 8.0 pCi/L, conduct a second Short-Term test and average its result with the result of the initial Short-Term test. If the average result of the two Short-Term tests is equal to or greater than 4.0 pCi/L, then radon in the room should be fixed (lowered).

All follow-up measurements in a school building should be conducted simultaneously. Follow-up measurements should be made in the same locations and under the same conditions as the initial measurements (to the extent possible, including similar seasonal conditions and especially HVAC system operation). If follow-up measurements using short-term tests are done, be sure to maintain closed-building conditions. This will ensure that the two results are as comparable as possible.

The higher the initial short-term test result, the more certain you can be that a short-term test should be used rather than a long-term follow-up test. In general, the higher the initial measurement, the greater the urgency to do a follow-up test as soon as possible. For example, if the initial short-term measurement for a room is several times the radon action level (e.g., at or above 8.0 pCi/L or higher), a short-term follow-up measurement should be taken immediately.

6.0 MITIGATION

In the event of a confirmed radon result over the EPA Action Level of 4.0 pCi/L, the following procedures will be followed:

- The sample(s) shall be validated by the radon consultant.
- The same area(s) will be retested in accordance with the OHA guidance document.
- After retesting the sample area shall be assessed by the appropriate District personnel and/or radon consultant for:
 - Adequate ventilation or pressurization issues - particularly common in basement rooms.
 - Evidence of structural damage to the slab or the wall slab juncture and/or obvious repairs areas, and
- The area may be resampled again after engineering controls have been administered.
- If short-term sample results continue to be above the EPA Action Level, long-term samples will be deployed.
- The District will, in a timely manner, consider mitigation systems if long-term sample results remain high and all other engineering controls have been exhausted.

7.0 RADON REPORTING AND DISTRIBUTION

ORS 332.166-167 requires that school districts make all test results available: to the district's school board; the Oregon Health Authority (to post on its website), and readily available to parents, guardians, students, school employees, school volunteers, administrators and community representatives at the school office, district office or on a website for the school or school district.

ATTACHMENTS

Attachment 1

Radon Sample Site Tables

TABLE 1**Radon Sampling for Schools and Facilities
New Sites and Sites with Additions Since 1989**

Site	Square Footage	Building Description	Estimated Sample Count
Admin Aloha Branch	5,000 SF	Slab on grade	20 samples
Aloha-Huber	107,000 SF	Two stories – slab on grade	65 samples
Bonny Slope	80,000 SF	Two stories – slab on grade	45 samples
Conestoga	129,000 SF	Slab on grade	75 samples
Findley	72,000 SF	Slab on grade	60 samples
H&SS/ Capital Center	189,000 SF	Slab on grade	110 samples
Jacob Wismer	73,000 SF	Slab on grade	60 samples
Merle Davies	39,000 SF	Slab on grade and crawl space combination	30 samples
Merlo Station	51,000 SF	Slab on grade	50 samples
Nancy Ryles	71,000 SF	Slab on grade	60 samples
Ridgewood	55,000 SF	Slab on grade	40 samples
Scholls Heights	70,000 SF	Slab on grade	60 samples
Sexton Mountain	70,000 SF	Crawl space and slab on grade combination-	60 samples
Southridge	256,000 SF	Slab on grade	130 samples
Springville	87,000 SF	Two stories – slab on grade	60 samples
Stoller	144,000 SF	Slab on grade	80 samples
Westview	281,000 SF	Slab on grade	140 samples
Transportation Allen	10,000 SF	Slab on grade	20 samples
Transportation & Support Center	54,000 SF	Slab on grade	40 samples
Transportation 5 th St. N.	5,200 SF	Slab on grade	20 samples

TABLE 1

**Radon Sampling for Schools and Facilities
New Sites and Sites with Additions Since 1989**

Site	Square Footage	Building Description	Estimated Sample Count
Transportation 5 th St. S.	26,000 SF	Slab on grade	20 samples

TABLE 2

**Radon Sampling for School and Support Facilities
Sites with Any Prior Elevated Radon Result
(Near or over EPA Action Level)**

School	Square Footage	Building Description	Recommended Samples
Aloha HS	260,000 SF	Slab on grade	130 samples
Beaver Acres	80,000 SF	Slab on grade	55 samples
Bethany	50,000 SF	Slab on grade	50 samples
Cedar Park	117,000 SF	Slab on grade	70 samples
Chehalem	54,000 SF	Slab on grade	50 samples
Errol Hassell	60,000 SF	Slab on grade	55 samples
Fir Grove	61,000 SF	Slab on grade	55 samples
Five Oaks	143,000 SF	Slab on grade	80 samples
Greenway	55,000 SF	Slab on grade	35 samples
Highland Park	117,000 SF	Slab on grade	70 samples
Hiteon	79,000 SF	Slab on grade	55 samples
Kinnaman	35,000 SF	Slab on grade	30 samples
McKay	46,000 SF	Slab on grade and basement	50 samples
McKinley	41,000 SF	Slab on grade	40 samples
Meadow Park	122,000 SF	Slab on grade	70 samples
Montclair	33,000 SF	Slab on grade	30 samples
Mountain View	136,000 SF	Slab on grade	80 samples
Raleigh Hills	57,000 SF	Basement	50 samples
Raleigh Park	44,000 SF	Slab on grade	40 samples
Sunset	209,000 SF	Slab on grade	120 samples
Terra Linda	43,000 SF	Slab on grade	40 samples
West Tualatin	35,000 SF	Slab on grade	30 samples
Whitford	123,000 SF	Slab on grade	70 samples
Administration	28,000 SF	Slab on grade	60 samples
Maintenance	26,000 SF	Slab on grade	30 samples

TABLE 3**Radon Sampling for School and Support Facilities
Sites with No Prior Radon Results**

School	Square Footage	Building Description	Recommended Samples
Barnes	76,000 SF	Basement	55 samples
Beaverton HS	264,000 SF	Slab on grade - 2 stories	130 samples
Cedar Mill	41,000 SF	Basement	30 samples
Cooper Mountain	55,000 SF	Slab on grade	40 samples
Elmonica	51,000 SF	Slab on grade	40 samples
Oak Hills	50,000 SF	Slab on grade	40 samples
Rock Creek	52,000 SF	Slab on grade	40 samples
Terra Nova	12,000 SF	Slab on grade	25 samples

Attachment 2

Radon Test Placement Protocol Checklist and Communication Memo

Appendix A: Radon test placement protocol checklist

Note: This document has been prepared to help schools and school districts conduct radon measurements in schools. The step-wise approach is aimed at helping school districts determine where to test, how many test kits are required, where to place test kits, and proper documentation of the process. This document is thus meant to be used as a general guideline, not a mandate. Each school will present a different situation. If specific questions or issues arise regarding testing in your school, contact the Oregon Radon Awareness Program at 971-673-0440 or email radon.program@state.or.us.

Important: Order all radon test kits for initial measurement at the same time. Kits should all be from the same manufacturing batch.

Test Kit Placement Guide

Once the number of test kits is determined, they need to be placed in the frequently occupied rooms as identified in the “What rooms should be tested?” section on [page 17](#).

1. Be sure to check these items before placing the radon test kits:
 - Closed building conditions have been maintained in the building for 12 hours.
 - HVAC system is operating as it normally would when students and faculty are present.
 - Testing is being done during a time that students and faculty are present.
2. As detectors are placed in the rooms, determined thorough and accurate data needs to be recorded on the device log and floor plan (see samples in Appendix D).

Protocol for all test kits include the following. Be sure that each detector placed is:

- In a location where it will be undisturbed;
- Out of direct sunlight;
- Three feet from all doors and windows;
- Four inches from all other objects;

- At least one foot from all exterior walls;
- At least 20 inches to 6 feet from the floor;
- Out of direct air flow from vents;
- Four feet from the heat source.

School measurement teams in other states simply place the test kit on the teacher's desk or out of the way of students on a bookshelf.

3. Specific protocol for duplicate measurements. If the test kit you are placing is a duplicate measurement also be sure to:
 - Place duplicate (side-by-side) test kit four to five inches away from test kit for that room
4. Specific protocol for blank measurements. If the test kit you are placing is a blank measurement, also be sure to:
 - Unwrap blanks and open, but then immediately close and reseal them.
 - Place the test kit next to the detector kit(s) for the room four to five inches away.
5. Specific protocol for spiked test kits.
 - Arrange for the spiked test kits to arrive back from the Certified Performance Test Chamber to the School Measurement Team as close as possible to the day that kits are retrieved from the school. [See “Quality assurance procedures for a school radon measurement program” on [page 31](#).]
6. Testing period.

The test kits should be left out no less than 48 hours but no more than seven days. [It's best to follow test kit manufacturer's instructions for more specific recommendations.] It's best if devices are left in place for four days to ensure optimum results.

Many schools place short-term kits on Monday morning and pick them up on Thursday morning.

MEMO - Radon Sampling in BSD Schools and Facilities

12/14/15

Radon is an important air quality concern that the Beaverton School District is committed to minimizing exposure to our students and staff at all of our schools and support facilities. Over the last 2 years, BSD has been developing a comprehensive radon sampling program tailored to our District. We have been collaborating with a qualified industrial hygiene consulting firm to help review the District's prior sampling data and to establish a robust sampling plan moving forward.

This effort is well timed with the passage of House Bill 2931 during the latest 2015 legislative session. HB 2931 requires all Oregon school districts to have a current radon plan and all schools to be tested for radon by 2021. BSD's Radon Program will be revised to incorporate requirements of this new law.

Radon sampling is easy and fast to set-up, kits are inexpensive, and the process will not disturb occupant activities. Sample kits are made up of inert granulated charcoal inside of a small paper envelope or canister similar to the photo below. The kits are placed in occupied rooms of a building that are basement level or are slab-on-grade floors. Sample kits are positioned at approximately 4ft height from the floor and generally in corners of rooms where airflow rates are more predictable. Each sample takes minutes to set up and remove and remains in place for a period of 2-3 days before it is collected and set to the laboratory for analysis.

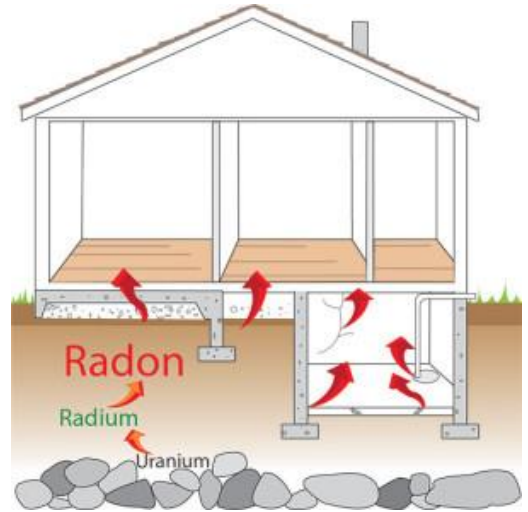

Starting this December, BSD will begin to collect targeted radon samples at schools and facilities that have no prior radon data. Buildings that have had square foot additions with no prior radon data will be sampled next. After that, remaining buildings will undergo targeted resampling. Initial sample counts will range between 6 and 20 samples depending on the areas and square footage to be covered. Results will be reviewed by our radon consultant and compiled in BSD's sampling database. Validated results will be provided to each school and

made available to the public upon request.

The District's radon program will be administered by the Maintenance Department. Look for notification that sampling will be occurring at your school in the coming weeks and months. Questions or Comments? Please contact Matt Lichtenfels at matthew.Lichtenfels@beaverton.k12.or.us or call 503.591.4223.

Other general radon information may be found here:

Summary Article on Oregon Radon Legislation HB2931:

<https://www.thelundreport.org/content/keny-guyer-wins-resounding-approval-radon-testing-schools>

Link to HB 2931: <https://olis.leg.state.or.us/liz/2015R1/Downloads/MeasureDocument/HB2931>

General radon information including understanding radon risks in your home: <http://www.epa.gov/radon>

Attachment 3

BSD Radon Sample Spreadsheet

2016 BSD Radon Sample Spreadsheet Database

Original Site #	Site Name	Facility Type	Test Date	Room Area Location	Sample Number	Result (pCi/l)	Test Type	Area Retested?	Test Date	Retested Sample #	Retested Sample Result (pCi/l)	Comments	Test Location on Floor Plan?	Misc	Result(value) (pCi/l)	Retested Sample Result (value) (pCi/l)
1	Aloha Park (Aloha Huber)	Elementary School (K-8)	8/9/89	Classroom 6	89-12553	2.3*	ST	N				Improperly Sealed	Y		2.3	
1	Aloha Park (Aloha Huber)	Elementary School (K-8)	8/9/89	Classroom 4	89-13764	2.1	ST	N					Y		2.1	
1	Aloha Park (Aloha Huber)	Elementary School (K-8)	8/9/89	Classroom 9	89-22722	1.9*	ST	N				Improperly Sealed	Y		1.9	
1	Aloha Park (Aloha Huber)	Elementary School (K-8)	8/9/89	Classroom 12	89-24288	<0.5	ST	N					Y		0	
1	Aloha Park (Aloha Huber)	Elementary School (K-8)	8/9/89	Classroom 17	89-13717	<0.5	ST	N					Y		0	
1	Aloha Park (Aloha Huber)	Elementary School (K-8)	8/9/89	Classroom 15	89-17594	<0.5	ST	N					Y		0	
1	Aloha Park (Aloha Huber)	Elementary School (K-8)	8/9/89	Classroom 2	89-13049	<0.5	ST	N					Y		0	
1	Aloha Park (Aloha Huber)	Elementary School (K-8)	8/9/89	Classroom 1	89-13814	<0.5	ST	N					Y		0	
1	Aloha Park (Aloha Huber)	Elementary School (K-8)	8/9/89	Classroom 11	89-25098	<0.5	ST	N					Y		0	
1	Aloha Park (Aloha Huber)	Elementary School (K-8)	8/9/89	Classroom 14	89-11809	<0.5	ST	N					Y		0	
1	Aloha Park (Aloha Huber)	Elementary School (K-8)	8/9/89	Gym?	89-12683	<0.5	ST	N					Y		0	
1	Aloha Park (Aloha Huber)	Elementary School (K-8)	8/9/89	Classroom 5	89-25911	<0.5	ST	N					Y		0	
1	Aloha Park (Aloha Huber)	Elementary School (K-8)	8/9/89	Classroom 10	89-14363	<0.5	ST	N					Y		0	
1	Aloha Park (Aloha Huber)	Elementary School (K-8)	8/9/89	Classroom 18	89-12665	<0.5	ST	N					Y		0	
1	Aloha Park (Aloha Huber)	Elementary School (K-8)	8/9/89	Classroom 16	89-19122	<0.5	ST	N					Y		0	
1	Aloha Park (Aloha Huber)	Elementary School (K-8)	8/9/89	Gym	89-13956	<0.5	ST	N					Y		0	
1	Aloha Park (Aloha Huber)	Elementary School (K-8)	8/9/89	Classroom 7	89-18769	<0.5	ST	N					Y		0	
1	Aloha Park (Aloha Huber)	Elementary School (K-8)	8/9/89	Cafeteria	89-18731	<0.5	ST	N					Y		0	
1	Aloha Park (Aloha Huber)	Elementary School (K-8)	8/9/89	Classroom 3	89-70879	<0.5	ST	N					Y		0	
2	Barnes	Elementary School	8/9/89	Classroom 11	89-17595	1.7	ST	N					Y		1.7	
2	Barnes	Elementary School	8/9/89	Classroom BH2	89-22941	1.3	ST	N					Y		1.3	
2	Barnes	Elementary School	8/9/89	Cafeteria	89-19109	1.2	ST	N					Y		1.2	
2	Barnes	Elementary School	8/9/89	Classroom B7	89-18733	1.2	ST	N					Y		1.2	
2	Barnes	Elementary School	8/9/89	GYM	89-14354	0.9	ST	N					Y		0.9	
2	Barnes	Elementary School	8/9/89	Classroom B5	89-13132	0.6	ST	N					Y		0.6	
2	Barnes	Elementary School	8/9/89	Library	89-25947	<0.5	ST	N					Y		0	
2	Barnes	Elementary School	8/9/89	Classroom 15	89-12289	<0.5	ST	N					Y		0	
2	Barnes	Elementary School	8/9/89	Classroom 17	89-25907	<0.5	ST	N					Y		0	
2	Barnes	Elementary School	8/9/89	GYM	89-22247	<0.5	ST	N					Y		0	
2	Barnes	Elementary School	8/9/89	Classroom 13	89-20889	<0.5	ST	N					Y		0	
3	Beaver Acres	Elementary School	8/9/89	Classroom 11	89-23849	4.8	ST	Y	11/13/89	89-18755	<0.5		Y		4.8	0
3	Beaver Acres	Elementary School	8/9/89	Classroom 4	89-17193	3.5	ST	N					Y		3.5	
3	Beaver Acres	Elementary School	8/9/89	Classroom 16	89-11801	2.9	ST	N					Y		2.9	
3	Beaver Acres	Elementary School	8/9/89	Cafeteria	89-14624	1.3	ST	N					Y		1.3	
3	Beaver Acres	Elementary School	8/9/89	Classroom 14	89-13407	<0.5	ST	N					Y		0	
3	Beaver Acres	Elementary School	8/9/89	Classroom 7	89-22592	<0.5	ST	N					Y		0	
3	Beaver Acres	Elementary School	8/9/89	Classroom 9	8914573	<0.5	ST	N					Y		0	
3	Beaver Acres	Elementary School	8/9/89	Classroom 5	89-12659	<0.5	ST	N					Y		0	
3	Beaver Acres	Elementary School	8/9/89	Classroom 12	89-23242	<0.5	ST	N					Y		0	
3	Beaver Acres	Elementary School	8/9/89	Gym	89-22505	<0.5	ST	N					Y		0	
3	Beaver Acres	Elementary School	8/9/89	Library	89-14374	<0.5	ST	N					Y		0	
3	Beaver Acres	Elementary School	8/9/89	Classroom 2	89-13075	<0.5	ST	N					Y		0	
3	Beaver Acres	Elementary School	8/9/89	Classroom 13	89-23245	<0.5	ST	N					Y		0	
3	Beaver Acres	Elementary School	8/9/89	Classroom 8	89-18730	<0.5	ST	N					Y		0	
3	Beaver Acres	Elementary School	8/9/89	Gym	89-15790	<0.5	ST	N					Y		0	
3	Beaver Acres	Elementary School	8/9/89	Classroom 10	89-13092	<0.5	ST	N					Y		0	
3	Beaver Acres	Elementary School	8/9/89	Classroom 15	89-13778	<0.5	ST	N					Y		0	
3	Beaver Acres	Elementary School	8/9/89	Classroom 3	89-22727	<0.5	ST	N					Y		0	
3	Beaver Acres	Elementary School	8/9/89	Classroom 1	89-13983	<0.5	ST	N					Y		0	
3	Beaver Acres	Elementary School	8/9/89	Classroom 6	89-25904	<0.5	ST	N					Y		0	
4	Bethany	Elementary School	8/8/89	Classroom 8	89-13745	5.4	ST	Y	11/6/89	89-18724	0.9		Y		5.4	0.9
4	Bethany	Elementary School	8/8/89	Classroom 5	89-13017	1.7	ST	N					Y		1.7	
4	Bethany	Elementary School	8/8/89	Library	89-23410	1.2	ST	N					Y		1.2	
4	Bethany	Elementary School	8/8/89	Gym	89-13891	1.1	ST	N					Y		1.1	
4	Bethany	Elementary School	8/8/89	Classroom 2	89-22914	0.9	ST	N					Y		0.9	
4	Bethany	Elementary School	8/8/89	Library	89-24255	0.8	ST	N					Y		0.8	
4	Bethany	Elementary School	8/8/89	Classroom 17	89-24221	<0.5	ST	N					Y		0	
4	Bethany	Elementary School	8/8/89	Classroom MUA	89-21231	<0.5	ST	N					Y		0	
4	Bethany	Elementary School	8/8/89	Classroom 13	89-25129	<0.5	ST	N					Y		0	
4	Bethany	Elementary School	8/8/89	Classroom 11	89-13015	<0.5	ST	N					Y		0	
4	Bethany	Elementary School	8/8/89	Classroom MUA	89-13719	<0.5	ST	N					Y		0	
4	Bethany	Elementary School	8/8/89	Gym	89-22711	<0.5	ST	N					Y		0	
4	Bethany	Elementary School	8/8/89	Gym	89-19403	<0.5	ST	N					Y		0	
4	Bethany	Elementary School	8/8/89	Cafeteria	89-24323	<0.5	ST	N					Y		0	
4	Bethany	Elementary School	8/8/89	Library annex	89-23487	<0.5	ST	N					Y		0	
4	Bethany	Elementary School	8/8/89	Classroom MUA	89-14562	<0.5	ST	N					Y		0	
5	Cedar Mill	Elementary School	8/8/89	Classroom 17	89-13042	3.4	ST	N					Y		3.4	
5	Cedar Mill	Elementary School	8/8/89	Classroom 2A	89-21829	2.1	ST	N					Y		2.1	
5	Cedar Mill	Elementary School	8/8/89	Classroom 14	89-13801	1.7	ST	N					Y		1.7	

2016 BSD Radon Sample Spreadsheet Database

Original Site #	Site Name	Facility Type	Test Date	Room Area Location	Sample Number	Result (pCi/l)	Test Type	Area Retested?	Test Date	Retested Sample #	Retested Sample Result (pCi/l)	Comments	Test Location on Floor Plan?	Misc	Result (value) (pCi/l)	Retested Sample Result (value) (pCi/l)
5	Cedar Mill	Elementary School	8/8/89	Classroom 8	89-14579	1.0	ST	N					Y		1.0	
5	Cedar Mill	Elementary School	8/8/89	GYM	89-12252	0.9	ST	N					Y		0.9	
5	Cedar Mill	Elementary School	8/8/89	Classroom 7	89-21824	<0.5	ST	N					Y		0	
5	Cedar Mill	Elementary School	8/8/89	Classroom UN	89-12679	<0.5	ST	N					Y		0	
5	Cedar Mill	Elementary School	8/8/89	GYM	89-20818	<0.5	ST	N					Y		0	
5	Cedar Mill	Elementary School	8/8/89	Library	89-21827	<0.5	ST	N					Y		0	
5	Cedar Mill	Elementary School	8/8/89	Classroom 13	89-23057	<0.5	ST	N					Y		0	
5	Cedar Mill	Elementary School	8/8/89	Classroom 5	89-13157	<0.5	ST	N					Y		0	
5	Cedar Mill	Elementary School	8/8/89	Classroom 4	89-8705	<0.5	ST	N					Y		0	
5	Cedar Mill	Elementary School	8/8/89	Classroom 6	89-25920	<0.5	ST	N					Y		0	
5	Cedar Mill	Elementary School	8/8/89	Classroom 1	89-20823	<0.5	ST	N					Y		0	
5	Cedar Mill	Elementary School	8/8/89	Classroom 2	89-23065	<0.5	ST	N					Y		0	
5	Cedar Mill	Elementary School	8/8/89	Classroom 2B	89-21823	<0.5	ST	N					Y		0	
6	Chehalem	Elementary School	8/9/89	Classroom 14	89-3779	5.5	ST	Y	9/14/89	89-2179	1.3*	Retest,11/6/89, 89-23548	Y		5.5	1.3
6	Chehalem	Elementary School	8/9/89	Classroom 3	89-2667	2.9	ST	N					Y		2.9	
6	Chehalem	Elementary School	8/9/89	Classroom MPR	89-7854	2.2	ST	N					Y		2.2	
6	Chehalem	Elementary School	8/9/89	Gym	89-3792	1.7	ST	N					Y		1.7	
6	Chehalem	Elementary School	8/9/89	Classroom 8	89-24215	0.7	ST	N					Y		0.7	
6	Chehalem	Elementary School	8/9/89	Classroom 1MC	89-21226	0.7	ST	N					Y		0.7	
6	Chehalem	Elementary School	8/9/89	Classroom MUR	89-12073	<0.5	ST	N					Y		0	
6	Chehalem	Elementary School	8/9/89	Gym	89-16554	<0.5	ST	N					Y		0	
6	Chehalem	Elementary School	8/9/89	Classroom MUR	89-16160	<0.5	ST	N					Y		0	
6	Chehalem	Elementary School	8/9/89	Classroom 17	89-25440	<0.5	ST	N					Y		0	
6	Chehalem	Elementary School	8/9/89	Classroom 11	89-25454	<0.5	ST	N					Y		0	
6	Chehalem	Elementary School	8/9/89	Classroom 14	89-22848	<0.5	ST	N					Y		0	
6	Chehalem	Elementary School	8/9/89	Cafeteria	89-16178	<0.5	ST	N					Y		0	
6	Chehalem	Elementary School	8/9/89	Classroom MPR	89-16175	<0.5	ST	N					Y		0	
6	Chehalem	Elementary School	8/9/89	Classroom 1	89-6240	<0.5	ST	N					Y		0	
7	Cooper Mountain	Elementary School	8/8/89	Classroom 14-15	89-16156	<0.5	ST	N					Y		0	
7	Cooper Mountain	Elementary School	8/8/89	Classroom 16-17	89-19931	<0.5	ST	N					Y		0	
7	Cooper Mountain	Elementary School	8/8/89	Classroom 13-14	89-16103	<0.5	ST	N					Y		0	
7	Cooper Mountain	Elementary School	8/8/89	Classroom 11-12	89-16523	<0.5	ST	N					Y		0	
7	Cooper Mountain	Elementary School	8/8/89	Classroom 10-11	89-16556	<0.5	ST	N					Y		0	
7	Cooper Mountain	Elementary School	8/8/89	Classroom PE-2	89-180	<0.5	ST	N					Y		0	
7	Cooper Mountain	Elementary School	8/8/89	Classroom 5-6	89-15360	<0.5	ST	N					Y		0	
7	Cooper Mountain	Elementary School	8/8/89	Classroom 2-3	89-16531	<0.5	ST	N					Y		0	
7	Cooper Mountain	Elementary School	8/8/89	Classroom 7-8	89-16124	<0.5	ST	N					Y		0	
7	Cooper Mountain	Elementary School	8/8/89	Classroom 1-2	89-16552	<0.5	ST	N					Y		0	
7	Cooper Mountain	Elementary School	8/8/89	Library	89-16150	<0.5	ST	N					Y		0	
7	Cooper Mountain	Elementary School	8/8/89	Cafeteria	89-19943	<0.5	ST	N					Y		0	
7	Cooper Mountain	Elementary School	8/8/89	Classroom 8-9	89-16524	<0.5	ST	N					Y		0	
7	Cooper Mountain	Elementary School	8/8/89	Classroom PE-1	89-16142	<0.5	ST	N					Y		0	
7	Cooper Mountain	Elementary School	8/8/89	Classroom 17-18	89-16550	<0.5	ST	N					Y		0	
7	Cooper Mountain	Elementary School	8/8/89	Classroom 4-5	89-16105	<0.5	ST	N					Y		0	
8	Elmonica	Elementary School	8/8/89	Classroom IMC	89-11556	2.1	ST	N					Y		2.1	
8	Elmonica	Elementary School	8/8/89	GYM	89-16143	0.9	ST	N					Y		0.9	
8	Elmonica	Elementary School	8/8/89	GYM	89-11752	0.9	ST	N					Y		0.9	
8	Elmonica	Elementary School	8/8/89	Classroom IMC	89-21758	0.6	ST	N					Y		0.6	
8	Elmonica	Elementary School	8/8/89	Classroom IMC	89-18291	<0.5	ST	N					Y		0	
8	Elmonica	Elementary School	8/8/89	Classroom IMC	89-10290	<0.5	ST	N					Y		0	
8	Elmonica	Elementary School	8/8/89	Classroom IMC	89-16522	<0.5	ST	N					Y		0	
8	Elmonica	Elementary School	8/8/89	Classroom MUS	89-24285	<0.5	ST	N					Y		0	
8	Elmonica	Elementary School	8/8/89	Classroom 2	89-19949	<0.5	ST	N					Y		0	
8	Elmonica	Elementary School	8/8/89	Cafeteria	89-16106	<0.5	ST	N					Y		0	
8	Elmonica	Elementary School	8/8/89	Classroom 11	89-12029	<0.5	ST	N					Y		0	
8	Elmonica	Elementary School	8/8/89	Classroom MUSA	89-2714	<0.5	ST	N					Y		0	
9	Errol Hassell	Elementary School	8/8/89	Classroom 312	89-10256	6.2	ST	Y	9/14/89	89-9717	4.4	11/6/89, 312, 89-24836,	Y		6.2	4.4
9	Errol Hassell	Elementary School	8/8/89	Classroom 210	89-16161	5.1	ST	Y	9/14/89	89-7462	2.5		Y		5.1	2.5
9	Errol Hassell	Elementary School	8/8/89	Classroom 315	89-16146	5.0	ST	Y	9/14/89	89-8471	3.9		Y		5.0	3.9
9	Errol Hassell	Elementary School	8/8/89	Classroom 206	89-3904	3.3	ST	N					Y		3.3	
9	Errol Hassell	Elementary School	8/8/89	Classroom 311	89-2774	3.2	ST	N					Y		3.2	
9	Errol Hassell	Elementary School	8/8/89	Classroom 203	89-7073	3.1	ST	N					Y		3.1	
9	Errol Hassell	Elementary School	8/8/89	Classroom 201N	89-12672	3.0	ST	N					Y		3.0	
9	Errol Hassell	Elementary School	8/8/89	Classroom 314	89-20483	2.9	ST	N					Y		2.9	
9	Errol Hassell	Elementary School	8/8/89	Classroom 201S	89-16137	2.8	ST	N					Y		2.8	
9	Errol Hassell	Elementary School	8/8/89	Classroom 213	89-4988	2.7	ST	N					Y		2.7	
9	Errol Hassell	Elementary School	8/8/89	Classroom 208	89-21533	2.5	ST	N					Y		2.5	
9	Errol Hassell	Elementary School	8/8/89	Gym W	89-12633	0.8	ST	N					Y		0.8	
9	Errol Hassell	Elementary School	8/8/89	Cafeteria	89-16521	<0.5	ST	N					Y		0	

2016 BSD Radon Sample Spreadsheet Database

Original Site #	Site Name	Facility Type	Test Date	Room Area Location	Sample Number	Result (pCi/l)	Test Type	Area Retested?	Test Date	Retested Sample #	Retested Sample Result (pCi/l)	Comments	Test Location on Floor Plan?	Misc	Result(value) (pCi/l)	Retested Sample Result (value) (pCi/l)
9	Errol Hassell	Elementary School	8/8/89	GYM	89-20474	<0.5	ST	N					Y		0	
9	Errol Hassell	Elementary School	8/8/89	Classroom Mod	89-16119	<0.5	ST	N					Y		0	
10	Fir Grove	Elementary School	8/8/89	Classroom 19	89-22716	5.4*	ST	Y	9/14/89	89-7443	2.6	Improperly Sealed	Y		5.4	2.6
10	Fir Grove	Elementary School	8/8/89	Classroom 8	89-16593	4.4	ST	Y	11/6/89	89-18778	1.8		Y		4.4	1.8
10	Fir Grove	Elementary School	8/8/89	Classroom 6	89-3908	4.0	ST	N					Y		4.0	
10	Fir Grove	Elementary School	8/8/89	Classroom 12	89-11595	4.0	ST	N					Y		4.0	
10	Fir Grove	Elementary School	8/8/89	Classroom 5	89-19161	3.8	ST	N					Y		3.8	
10	Fir Grove	Elementary School	8/8/89	Classroom 1	89-12691	3.5	ST	N					Y		3.5	
10	Fir Grove	Elementary School	8/8/89	Classroom 14	89-13507	2.5	ST	N					Y		2.5	
10	Fir Grove	Elementary School	8/8/89	Classroom Library S	89-20494	2.4	ST	N					Y		2.4	
10	Fir Grove	Elementary School	8/8/89	Classroom 17	89-9025	2.3	ST	N					Y		2.3	
10	Fir Grove	Elementary School	8/8/89	Classroom 15	89-16518	2.2	ST	N				Duplicate	Y		2.2	
10	Fir Grove	Elementary School	8/8/89	Classroom 15	89-16518	2.2	ST	N				Duplicate	Y		2.2	
10	Fir Grove	Elementary School	8/8/89	Classroom 22	89-20477	1.3	ST	N					Y		1.3	
10	Fir Grove	Elementary School	8/8/89	Classroom 2	89-2793	1.2	ST	N					Y		1.2	
10	Fir Grove	Elementary School	8/8/89	Classroom 18	89-18729	1.1	ST	N					Y		1.1	
10	Fir Grove	Elementary School	8/8/89	Classroom Play Rm	89-21753	0.6	ST	N					Y		0.6	
10	Fir Grove	Elementary School	8/8/89	Classroom 20	89-23241	<0.5	ST	N					Y		0	
10	Fir Grove	Elementary School	8/8/89	Library N	89-16555	<0.5	ST	N					Y		0	
10	Fir Grove	Elementary School	8/8/89	Classroom MPR N	89-4636	<0.5	ST	N					Y		0	
10	Fir Grove	Elementary School	8/8/89	Classroom 16	89-23232	<0.5*	ST	N				Improperly Sealed	Y		0	
10	Fir Grove	Elementary School	8/8/89	Classroom 21	89-25486	<0.5	ST	N					Y		0	
10	Fir Grove	Elementary School	8/8/89	Cafeteria	89-3919	<0.5	ST	N					Y		0	
10	Fir Grove	Elementary School	8/8/89	Classroom 4	89-25721	<0.5	ST	N					Y		0	
10	Fir Grove	Elementary School	8/8/89	Library	89-25488	<0.5	ST	N					Y		0	
10	Fir Grove	Elementary School	8/8/89	Classroom 11	89-23250	<0.5	ST	N					Y		0	
10	Fir Grove	Elementary School	8/8/89	Classroom MPR S	89-13494	<0.5	ST	N					Y		0	
11	Greenway	Elementary School	8/8/89	Classroom 13	89-12074	8.3	ST	Y	11/6/89	89-23771	3.8		Y		8.3	3.8
11	Greenway	Elementary School	8/8/89	Classroom 28	89-4677	4.9	ST	Y	11/6/89	89-18713	6.2		Y		4.9	6.2
11	Greenway	Elementary School	8/8/89	Classroom 32	89-6266	3.9	ST	N					Y		3.9	
11	Greenway	Elementary School	8/8/89	Classroom 26	89-18195	3.2	ST	N					Y		3.2	
11	Greenway	Elementary School	8/8/89	Classroom 11	89-2721	2.7	ST	N					Y		2.7	
11	Greenway	Elementary School	8/8/89	Classroom 31	89-18129	2.5	ST	N					Y		2.5	
11	Greenway	Elementary School	8/8/89	Media Ctr B	89-2773	2.0	ST	N					Y		2.0	
11	Greenway	Elementary School	8/8/89	Classroom 4	89-22340	1.7	ST	N					Y		1.7	
11	Greenway	Elementary School	8/8/89	Classroom 8	89-18121	1.4	ST	N					Y		1.4	
11	Greenway	Elementary School	8/8/89	Classroom 6	89-22775	1.4	ST	N					Y		1.4	
11	Greenway	Elementary School	8/8/89	Media Ctr	89-21567	0.9	ST	N					Y		0.9	
11	Greenway	Elementary School	8/8/89	GYM	89-8937	0.8	ST	N					Y		0.8	
11	Greenway	Elementary School	8/8/89	Classroom 1	89-22282	<0.5	ST	N					Y		0	
11	Greenway	Elementary School	8/8/89	GYM	89-1896	<0.5	ST	N					Y		0	
11	Greenway	Elementary School	8/8/89	Music Rm	89-7844	<0.5	ST	N					Y		0	
11	Greenway	Elementary School	8/8/89	Cafeteria	89-22234	<0.5	ST	N					Y		0	
12	Hazeldale	Elementary School	8/8/89	Classroom MPR	89-16038	4.1	ST	Y	11/16/89	89-18697	1.5		Y		4.1	1.5
12	Hazeldale	Elementary School	8/8/89	Classroom 8	89-12696	2.7	ST	N					Y		2.7	
12	Hazeldale	Elementary School	8/8/89	Classroom 0	89-16048	2.7	ST	N					Y		2.7	
12	Hazeldale	Elementary School	8/8/89	Classroom 4	89-25386	2.1	ST	N					Y		2.1	
12	Hazeldale	Elementary School	8/8/89	Classroom 14	89-20471	2.1	ST	N					Y		2.1	
12	Hazeldale	Elementary School	8/8/89	Classroom 3	89-18163	1.9	ST	N					Y		1.9	
12	Hazeldale	Elementary School	8/8/89	Classroom 12	89-25719	1.1	ST	N					Y		1.1	
12	Hazeldale	Elementary School	8/8/89	GYM	89-25507	1.1	ST	N					Y		1.1	
12	Hazeldale	Elementary School	8/8/89	Classroom 16	89-6980	<0.5	ST	N					Y		0	
12	Hazeldale	Elementary School	8/8/89	Classroom IMC	89-12670	<0.5	ST	N					Y		0	
12	Hazeldale	Elementary School	8/8/89	Classroom MPR	89-9811	<0.5	ST	N					Y		0	
12	Hazeldale	Elementary School	8/8/89	Classroom IMC	89-23091	<0.5	ST	N					Y		0	
12	Hazeldale	Elementary School	8/8/89	Classroom 9	89-2756	<0.5	ST	N					Y		0	
12	Hazeldale	Elementary School	8/8/89	Classroom 11	89-25404	<0.5	ST	N					Y		0	
12	Hazeldale	Elementary School	8/8/89	Classroom 5	89-12070	<0.5	ST	N					Y		0	
12	Hazeldale	Elementary School	8/8/89	Classroom 2	89-23936	<0.5	ST	N					Y		0	
12	Hazeldale	Elementary School	8/8/89	Music Rm	89-18223	<0.5	ST	N					Y		0	
12	Hazeldale	Elementary School	8/8/89	Classroom 6	89-2666	<0.5	ST	N					Y		0	
12	Hazeldale	Elementary School	8/8/89	Classroom 7	89-10154	<0.5	ST	N					Y		0	
12	Hazeldale	Elementary School	8/8/89	GYM	89-2727	<0.5	ST	N					Y		0	
12	Hazeldale	Elementary School	8/8/89	Classroom 1	89-4990	<0.5	ST	N					Y		0	
13	Hiteon	Elementary School	8/8/89	Classroom 108	89-6900	7.0	ST	Y	9/14/89	89-4993	1.0		Y		7.0	1.0
13	Hiteon	Elementary School	8/8/89	2 Cafeteria	89-25400	3.7	ST	N					Y		3.7	
13	Hiteon	Elementary School	8/8/89	Classroom 105	89-24845	3.7	ST	N					Y		3.7	
13	Hiteon	Elementary School	8/8/89	Classroom IMC	89-19306	3.5	ST	N					Y		3.5	

2016 BSD Radon Sample Spreadsheet Database

Original Site #	Site Name	Facility Type	Test Date	Room Area Location	Sample Number	Result (pCi/l)	Test Type	Area Retested?	Test Date	Retested Sample #	Retested Sample Result (pCi/l)	Comments	Test Location on Floor Plan?	Misc	Result(value) (pCi/l)	Retested Sample Result (value) (pCi/l)
13	Hiteon	Elementary School	8/8/89	Classroom 307	89-1670	2.4	ST	N					Y		2.4	
13	Hiteon	Elementary School	8/8/89	2 GYM	89-22570	2.3	ST	N					Y		2.3	
13	Hiteon	Elementary School	8/8/89	Classroom 309 (Kind)	89-2702	2.0	ST	N					Y		2.0	
13	Hiteon	Elementary School	8/8/89	IMC Lib	89-6715	1.2	ST	N					Y		1.2	
13	Hiteon	Elementary School	8/8/89	Classroom 101	89-12637	<0.5	ST	N					Y		0	
13	Hiteon	Elementary School	8/8/89	IMC Lib	89-17764	<0.5	ST	N					Y		0	
13	Hiteon	Elementary School	8/8/89	IMC Lib	89-11730	<0.5	ST	N					Y		0	
13	Hiteon	Elementary School	8/8/89	2B Café	89-18161	<0.5	ST	N					Y		0	
13	Hiteon	Elementary School	8/8/89	Classroom 305	89-22513	<0.5	ST	N					Y		0	
13	Hiteon	Elementary School	8/8/89	IMC Lib	89-23004	<0.5	ST	N					Y		0	
13	Hiteon	Elementary School	8/8/89	Classroom 302	89-20438	<0.5	ST	N					Y		0	
13	Hiteon	Elementary School	8/8/89	Classroom 310	89-1876	<0.5	ST	N					Y		0	
13	Hiteon	Elementary School	8/8/89	Classroom 301	89-3793	<0.5	ST	N					Y		0	
13	Hiteon	Elementary School	8/8/89	IMC Lib	89-2980	<0.5	ST	N					Y		0	
13	Hiteon	Elementary School	8/8/89	Classroom 113	89-16187	<0.5	ST	N					Y		0	
13	Hiteon	Elementary School	8/8/89	Classroom 308	89-16144	<0.5	ST	N					Y		0	
13	Hiteon	Elementary School	8/8/89	Classroom 306	89-16581	<0.5	ST	N					Y		0	
13	Hiteon	Elementary School	8/8/89	2 GYM	89-16557	<0.5	ST	N					Y		0	
14	Kinnaman	Elementary School	8/8/89	Music Rm	89-18699	4.5	ST	Y	11/6/89	89-24868	2.7		Y		4.5	2.7
14	Kinnaman	Elementary School	8/8/89	Classroom 5/6	89-25457	1.4	ST	N					Y		1.4	
14	Kinnaman	Elementary School	8/8/89	GYM S	89-17621	<0.5	ST	N					Y		0	
14	Kinnaman	Elementary School	8/8/89	Café N	89-18728	<0.5	ST	N					Y		0	
14	Kinnaman	Elementary School	8/8/89	Classroom 10	89-18763	<0.5	ST	N					Y		0	
14	Kinnaman	Elementary School	8/8/89	Café S	89-25706	<0.5	ST	N					Y		0	
14	Kinnaman	Elementary School	8/8/89	MUR Lib	89-12671	<0.5	ST	N					Y		0	
14	Kinnaman	Elementary School	8/8/89	GYM N	89-23792	<0.5	ST	N					Y		0	
14	Kinnaman	Elementary School	8/8/89	Classroom 3	89-23746	<0.5	ST	N					Y		0	
14	Kinnaman	Elementary School	8/8/89	Classroom 1K	89-19476	<0.5	ST	N					Y		0	
14	Kinnaman	Elementary School	8/8/89	Classroom 7/8	89-10162	<0.5	ST	N					Y		0	
14	Kinnaman	Elementary School	8/8/89	Classroom 12K	89-12692	<0.5	ST	N					Y		0	
15	McKay	Elementary School	8/9/89	Classroom MPR	89-18118	4.7	ST	Y	11/27/89	89-25476	1.6	1/29/89, 89-23885, 0.8pC	Y		4.7	1.6
15	McKay	Elementary School	8/9/89	Classroom ORCH	89-19930	2.3	ST	N					Y		2.3	
15	McKay	Elementary School	8/9/89	Cafeteria	89-17768	2.3	ST	N					Y		2.3	
15	McKay	Elementary School	8/9/89	Classroom 10	89-25776	2.1	ST	N					Y		2.1	
15	McKay	Elementary School	8/9/89	Classroom 14	89-25398	0.7	ST	N					Y		0.7	
15	McKay	Elementary School	8/9/89	Classroom 16	89-24849	<0.5	ST	N					Y		0	
15	McKay	Elementary School	8/9/89	BAND	89-2232	<0.5	ST	N					Y		0	
15	McKay	Elementary School	8/9/89	Classroom 15	89-23912	<0.5	ST	N					Y		0	
15	McKay	Elementary School	8/9/89	Classroom 18	89-22793	<0.5	ST	N					Y		0	
15	McKay	Elementary School	8/9/89	LIBRARY	89-8934	<0.5	ST	N					Y		0	
15	McKay	Elementary School	8/9/89	KG	89-22200	<0.5	ST	N					Y		0	
15	McKay	Elementary School	8/9/89	Classroom 0	89-3776	<0.5	ST	N					Y		0	
15	McKay	Elementary School	8/9/89	Classroom MPR	89-18701	<0.5	ST	N					Y		0	
15	McKay	Elementary School	8/9/89	Classroom 1	89-14355	<0.5	ST	N					Y		0	
15	McKay	Elementary School	8/9/89	Classroom 9	89-18151	<0.5	ST	N					Y		0	
15	McKay	Elementary School	8/9/89	Classroom 17	89-23740	<0.5	ST	N					Y		0	
15	McKay	Elementary School	8/9/89	Classroom 2	89-22530	<0.5	ST	N					Y		0	
16	McKinley	Elementary School	8/9/89	Classroom 15	89-18136	5.5	ST	Y	9/14/89	89-19168	3.4		Y		5.5	3.4
16	McKinley	Elementary School	8/9/89	Classroom 8	89-20587	3.7	ST	N					Y		3.7	
16	McKinley	Elementary School	8/9/89	Classroom 16	89-22251	3.4	ST	N					Y		3.4	
16	McKinley	Elementary School	8/9/89	Classroom 6	89-20689	3.4	ST	N					Y		3.4	
16	McKinley	Elementary School	8/9/89	Classroom 14	89-22208	3.2	ST	N					Y		3.2	
16	McKinley	Elementary School	8/9/89	Cafeteria	89-22370	3.1	ST	N					Y		3.1	
16	McKinley	Elementary School	8/9/89	Classroom 10	89-19266	1.6	ST	N					Y		1.6	
16	McKinley	Elementary School	8/9/89	Classroom 3	89-25489	1.6	ST	N					Y		1.6	
16	McKinley	Elementary School	8/9/89	Classroom 17	89-19426	1.3	ST	N					Y		1.3	
16	McKinley	Elementary School	8/9/89	Classroom 13	89-19427	1.2	ST	N					Y		1.2	
16	McKinley	Elementary School	8/9/89	Classroom 4	89-22221	1.1	ST	N					Y		1.1	
16	McKinley	Elementary School	8/9/89	Library	89-4709	1.0	ST	N					Y		1.0	
16	McKinley	Elementary School	8/9/89	Classroom 1	89-14598	0.9	ST	N					Y		0.9	
16	McKinley	Elementary School	8/9/89	Classroom 18	89-25746	0.8	ST	N					Y		0.8	
16	McKinley	Elementary School	8/9/89	Classroom 2	89-21453	<0.5	ST	N					Y		0	
16	McKinley	Elementary School	8/9/89	Classroom 9	89-19300	<0.5	ST	N					Y		0	
16	McKinley	Elementary School	8/9/89	Classroom 7	89-25744	<0.5	ST	N					Y		0	
16	McKinley	Elementary School	8/9/89	Classroom 5	89-21419	0.5	ST	N					Y		0.5	
16	McKinley	Elementary School	8/9/89	Classroom 12	89-22293	0.5	ST	N					Y		0.5	
16	McKinley	Elementary School	8/9/89	Classroom 11	89-22270	<0.5	ST	N					Y		0	
16	McKinley	Elementary School	8/9/89	Classroom MPR	89-25777	<0.5	ST	N					Y		0	
16	McKinley	Elementary School	8/9/89	Classroom MPR	89-25563	<0.5	ST	N					Y		0	

2016 BSD Radon Sample Spreadsheet Database

Original Site #	Site Name	Facility Type	Test Date	Room Area Location	Sample Number	Result (pCi/l)	Test Type	Area Retested?	Test Date	Retested Sample #	Retested Sample Result (pCi/l)	Comments	Test Location on Floor Plan?	Misc	Result (value) (pCi/l)	Retested Sample Result (value) (pCi/l)
17	Merle Davies	Elementary School	8/9/89	Classroom 4	89-13062	1.2*	ST	N				Improperly Sealed	Y		1.2	
17	Merle Davies	Elementary School	8/9/89	Classroom 5	89-25523	<0.5	ST	N					Y		0	
17	Merle Davies	Elementary School	8/9/89	Classroom 3	89-25467	<0.5	ST	N					Y		0	
17	Merle Davies	Elementary School	8/9/89	Classroom 8	89-23799	<0.5*	ST	N				Improperly Sealed	Y		0	
17	Merle Davies	Elementary School	8/9/89	Classroom 10	89-23460	<0.5	ST	N					Y		0	
17	Merle Davies	Elementary School	8/9/89	Classroom 2	89-22314	<0.5	ST	N					Y		0	
17	Merle Davies	Elementary School	8/9/89	Classroom 6	89-10821	<0.5	ST	N					Y		0	
17	Merle Davies	Elementary School	8/9/89	Classroom 1	89-19216	<0.5	ST	N					Y		0	
17	Merle Davies	Elementary School	8/9/89	Classroom 11	89-22292	<0.5	ST	N					Y		0	
17	Merle Davies	Elementary School	8/9/89	Cafeteria	89-25416	<0.5	ST	N					Y		0	
17	Merle Davies	Elementary School	8/9/89	Gym S	89-3431	<0.5	ST	N					Y		0	
17	Merle Davies	Elementary School	8/9/89	Gym N	89-22294	<0.5	ST	N					Y		0	
17	Merle Davies	Elementary School	8/9/89	Classroom 13	89-21586	<0.5	ST	N					Y		0	
17	Merle Davies	Elementary School	8/9/89	Classroom 12	89-18198	<0.5	ST	N					Y		0	
17	Merle Davies	Elementary School	8/9/89	Classroom 9	89-20560	<0.5	ST	N					Y		0	
17	Merle Davies	Elementary School	8/9/89	Classroom MD4	89-10894	<0.5	ST	N					Y		0	
17	Merle Davies	Elementary School	8/9/89	Classroom 7	89-18134	<0.5	ST	N					Y		0	
18	Montclair	Elementary School	8/8/89	Classroom 5	89-8938	5.1	ST	Y	9/14/89	89-4484	2.0		Y		5.1	2.0
18	Montclair	Elementary School	8/8/89	Cafeteria	89-6960	4.4	ST	N					Y		4.4	
18	Montclair	Elementary School	8/8/89	GYM West	89-10872	2.8	ST	N					Y		2.8	
18	Montclair	Elementary School	8/8/89	Classroom 2	89-8874	2.4	ST	N					Y		2.4	
18	Montclair	Elementary School	8/8/89	GYM East	89-10151	1.6	ST	N					Y		1.6	
18	Montclair	Elementary School	8/8/89	Multiuse Library	89-7830	1.0	ST	N					Y		1.0	
18	Montclair	Elementary School	8/8/89	East End	89-16461	0.8	ST	N					Y		0.8	
18	Montclair	Elementary School	8/8/89	Classroom 11	89-2947	<0.5	ST	N					Y		0	
18	Montclair	Elementary School	8/8/89	West End	89-6938	<0.5	ST	N					Y		0	
18	Montclair	Elementary School	8/8/89	Classroom 8	89-22230	<0.5	ST	N					Y		0	
19	Oak Hills	Elementary School	8/8/89	2 Gym	89-19157	2.3	ST	N					Y		2.3	
19	Oak Hills	Elementary School	8/8/89	Classroom 15	89-13805	1.2	ST	N					Y		1.2	
19	Oak Hills	Elementary School	8/8/89	Classroom 18	89-2228	0.8	ST	N					Y		0.8	
19	Oak Hills	Elementary School	8/8/89	Classroom 13	89-3452	<0.5	ST	N					Y		0	
19	Oak Hills	Elementary School	8/8/89	Classroom 5	89-16437	<0.5	ST	N					Y		0	
19	Oak Hills	Elementary School	8/8/89	Classroom 6	89-22388	<0.5	ST	N					Y		0	
19	Oak Hills	Elementary School	8/8/89	Classroom 2	89-7848	<0.5	ST	N					Y		0	
19	Oak Hills	Elementary School	8/8/89	Classroom 2	89-2969	<0.5	ST	N					Y		0	
19	Oak Hills	Elementary School	8/8/89	Classroom 8	89-2998	<0.5	ST	N					Y		0	
19	Oak Hills	Elementary School	8/8/89	Classroom 10	89-14306	<0.5	ST	N					Y		0	
19	Oak Hills	Elementary School	8/8/89	Classroom 9	89-22237	<0.5	ST	N					Y		0	
19	Oak Hills	Elementary School	8/8/89	Classroom 11	89-20586	<0.5	ST	N					Y		0	
19	Oak Hills	Elementary School	8/8/89	Classroom 4	89-6994	<0.5	ST	N					Y		0	
19	Oak Hills	Elementary School	8/8/89	Classroom 1	89-16458	<0.5	ST	N					Y		0	
19	Oak Hills	Elementary School	8/8/89	Classroom 7	89-22377	<0.5	ST	N					Y		0	
19	Oak Hills	Elementary School	8/8/89	Classroom 17	89-2999	<0.5	ST	N					Y		0	
19	Oak Hills	Elementary School	8/8/89	Classroom 7E	89-21403	<0.5	ST	N					Y		0	
19	Oak Hills	Elementary School	8/8/89	Classroom 3	89-2990	<0.5	ST	N					Y		0	
19	Oak Hills	Elementary School	8/8/89	Classroom 7W	89-18799	<0.5	ST	N					Y		0	
19	Oak Hills	Elementary School	8/8/89	Classroom 12	89-19153	<0.5	ST	N					Y		0	
19	Oak Hills	Elementary School	8/8/89	1 Café	89-22331	<0.5	ST	N					Y		0	
20	Raleigh Hills	Elementary School	8/9/89	GYM	89-4951	3.7	ST	N					Y		3.7	
20	Raleigh Hills	Elementary School	8/9/89	Classroom 6	89-4930	3.3	ST	N					Y		3.3	
20	Raleigh Hills	Elementary School	8/9/89	Classroom 8	89-12104	2.9	ST	N					Y		2.9	
20	Raleigh Hills	Elementary School	8/9/89	Classroom 5	89-2991	1.7	ST	N					Y		1.7	
20	Raleigh Hills	Elementary School	8/9/89	Classroom 1	89-16937	1.7	ST	N					Y		1.7	
20	Raleigh Hills	Elementary School	8/9/89	Classroom 9	89-4954	1.6	ST	N					Y		1.6	
20	Raleigh Hills	Elementary School	8/9/89	Classroom 7	89-9738	1.4	ST	N					Y		1.4	
20	Raleigh Hills	Elementary School	8/9/89	Classroom 104	89-4952	1.0	ST	N					Y		1.0	
20	Raleigh Hills	Elementary School	8/9/89	Cafeteria	89-2993	0.9	ST	N					Y		0.9	
20	Raleigh Hills	Elementary School	8/9/89	GYM	89-13840	0.7	ST	N					Y		0.7	
20	Raleigh Hills	Elementary School	8/9/89	Classroom 105	89-22236	<0.5	ST	N					Y		0	
20	Raleigh Hills	Elementary School	8/9/89	Classroom 101	89-11778	<0.5	ST	N					Y		0	
20	Raleigh Hills	Elementary School	8/9/89	Classroom 2	89-3326	<0.5	ST	N					Y		0	
20	Raleigh Hills	Elementary School	8/9/89	Classroom 4	89-4956	<0.5	ST	N					Y		0	
20	Raleigh Hills	Elementary School	8/9/89	Classroom 11	89-10409	<0.5	ST	N					Y		0	
20	Raleigh Hills	Elementary School	8/9/89	Classroom 10	89-25405	0.5	ST	N					Y		0.5	
20	Raleigh Hills	Elementary School	8/9/89	Classroom 12	89-4939	<0.5	ST	N					Y		0	
20	Raleigh Hills	Elementary School	8/9/89	Classroom 13	89-4948	<0.5	ST	N					Y		0	
20	Raleigh Hills	Elementary School	8/9/89	Cafeteria	89-4946	<0.5	ST	N					Y		0	
20	Raleigh Hills	Elementary School	8/9/89	Classroom S	89-3325	<0.5	ST	N					Y		0	
20	Raleigh Hills	Elementary School	8/9/89	Classroom 102	89-5254	<0.5	ST	N					Y		0	

2016 BSD Radon Sample Spreadsheet Database

Original Site #	Site Name	Facility Type	Test Date	Room Area Location	Sample Number	Result (pCi/l)	Test Type	Area Retested?	Test Date	Retested Sample #	Retested Sample Result (pCi/l)	Comments	Test Location on Floor Plan?	Misc	Result (value) (pCi/l)	Retested Sample Result (value) (pCi/l)
20	Raleigh Hills	Elementary School	8/9/89	Classroom 3	89-9737	<0.5	ST	N					Y		0	
21	Raleigh Park	Elementary School	8/9/89	Classroom 5	89-8450	5.1	ST	Y	9/18/89	89-2685	<0.5		Y		5.1	0
21	Raleigh Park	Elementary School	8/9/89	Classroom 12	89-4944	2.9	ST	N					Y		2.9	
21	Raleigh Park	Elementary School	8/9/89	Classroom 3	89-8469	2.3	ST	N					Y		2.3	
21	Raleigh Park	Elementary School	8/9/89	Classroom 13	89-16939	1.1	ST	N					Y		1.1	
21	Raleigh Park	Elementary School	8/9/89	GYM	89-6587	<0.5	ST	N					Y		0	
21	Raleigh Park	Elementary School	8/9/89	Classroom 17A	89-4940	<0.5	ST	N					Y		0	
21	Raleigh Park	Elementary School	8/9/89	Classroom IMC	89-5264	<0.5	ST	N					Y		0	
21	Raleigh Park	Elementary School	8/9/89	Classroom 8	89-6615	<0.5	ST	N					Y		0	
21	Raleigh Park	Elementary School	8/9/89	Classroom 6	89-5217	<0.5	ST	N					Y		0	
21	Raleigh Park	Elementary School	8/9/89	Classroom MPR	89-6583	<0.5	ST	N					Y		0	
21	Raleigh Park	Elementary School	8/9/89	Classroom 9	89-7483	<0.5	ST	N					Y		0	
21	Raleigh Park	Elementary School	8/9/89	GYM	89-5256	<0.5	ST	N					Y		0	
21	Raleigh Park	Elementary School	8/9/89	Classroom 14	89-5268	<0.5	ST	N					Y		0	
21	Raleigh Park	Elementary School	8/9/89	Classroom 4	89-4577	<0.5	ST	N					Y		0	
21	Raleigh Park	Elementary School	8/9/89	Classroom 8	89-9497	<0.5	ST	N					Y		0	
21	Raleigh Park	Elementary School	8/9/89	Classroom 2	89-4583	<0.5	ST	N					Y		0	
21	Raleigh Park	Elementary School	8/9/89	MPR	89-7473	<0.5*	ST	N				Improperly Sealed	Y		0	
21	Raleigh Park	Elementary School	8/9/89	Classroom 7	89-7463	<0.5	ST	N					Y		0	
21	Raleigh Park	Elementary School	8/9/89	Classroom 17	89-4856	<0.5*	ST	N				Improperly Sealed	Y		0	
21	Raleigh Park	Elementary School	8/9/89	Classroom 15	89-9758	<0.5	ST	N					Y		0	
21	Raleigh Park	Elementary School	8/9/89	Classroom 1	89-7466	<0.5	ST	N					Y		0	
21	Raleigh Park	Elementary School	8/9/89	Classroom 11	89-7492	<0.5	ST	N					Y		0	
22	Ridgewood	Elementary School	8/9/89	Unknown	89-3324	4.5	ST	N					Y		4.5	
22	Ridgewood	Elementary School	8/9/89	Unknown	89-11701	2.4	ST	N					Y		2.4	
22	Ridgewood	Elementary School	8/9/89	Unknown	89-9719	1.6	ST	N					Y		1.6	
22	Ridgewood	Elementary School	8/9/89	Unknown	89-9757	1.6	ST	N					Y		1.6	
22	Ridgewood	Elementary School	8/9/89	Unknown	89-7467	1.3	ST	N					Y		1.3	
22	Ridgewood	Elementary School	8/9/89	Unknown	89-4957	1.2	ST	N					Y		1.2	
22	Ridgewood	Elementary School	8/9/89	Unknown	89-9756	1.1	ST	N					Y		1.1	
22	Ridgewood	Elementary School	8/9/89	Unknown	89-4572	<0.5	ST	N					Y		0	
22	Ridgewood	Elementary School	8/9/89	Unknown	89-11780	<0.5	ST	N					Y		0	
22	Ridgewood	Elementary School	8/9/89	Unknown	89-4834	<0.5	ST	N					Y		0	
22	Ridgewood	Elementary School	8/9/89	Unknown	89-4814	<0.5	ST	N					Y		0	
22	Ridgewood	Elementary School	8/9/89	Unknown	89-4582	<0.5	ST	N					Y		0	
22	Ridgewood	Elementary School	8/9/89	Unknown	89-4959	<0.5	ST	N					Y		0	
22	Ridgewood	Elementary School	8/9/89	Unknown	89-11779	<0.5	ST	N					Y		0	
22	Ridgewood	Elementary School	8/9/89	Unknown	89-3944	<0.5	ST	N					Y		0	
22	Ridgewood	Elementary School	8/9/89	Unknown	89-2646	<0.5	ST	N					Y		0	
22	Ridgewood	Elementary School	8/9/89	Unknown	89-3345	<0.5	ST	N					Y		0	
22	Ridgewood	Elementary School	8/9/89	Unknown	89-3304	<0.5	ST	N					Y		0	
22	Ridgewood	Elementary School	8/9/89	Unknown	89-4013	<0.5	ST	N					Y		0	
22	Ridgewood	Elementary School	8/9/89	Unknown	89-5238	<0.5	ST	N					Y		0	
22	Ridgewood	Elementary School	8/9/89	Unknown	89-4015	<0.5	ST	N					Y		0	
22	Ridgewood	Elementary School	8/9/89	Unknown	89-8473	<0.5	ST	N					Y		0	
22	Ridgewood	Elementary School	8/9/89	Unknown	89-6582	<0.5	ST	N					Y		0	
22	Ridgewood	Elementary School	8/9/89	Unknown	89-6614	<0.5	ST	N					Y		0	
23	Rock Creek	Elementary School	8/8/89	Classroom 102	89-9765	1.5	ST	N					Y		1.5	
23	Rock Creek	Elementary School	8/8/89	Library	89-7474	1.5	ST	N					Y		1.5	
23	Rock Creek	Elementary School	8/8/89	GYM	89-7495	1.4	ST	N					Y		1.4	
23	Rock Creek	Elementary School	8/8/89	Classroom 111	89-2687	1.3	ST	N					Y		1.3	
23	Rock Creek	Elementary School	8/8/89	Library	89-9718	1.3	ST	N					Y		1.3	
23	Rock Creek	Elementary School	8/8/89	Library	89-4566	1.1	ST	N					Y		1.1	
23	Rock Creek	Elementary School	8/8/89	Classroom 108	89-3303	1.0	ST	N					Y		1.0	
23	Rock Creek	Elementary School	8/8/89	Music Rm	89-3364	1.0	ST	N					Y		1.0	
23	Rock Creek	Elementary School	8/8/89	Classroom 105	89-9752	0.9	ST	N					Y		0.9	
23	Rock Creek	Elementary School	8/8/89	Music Rm B	89-2686	<0.5	ST	N					Y		0	
23	Rock Creek	Elementary School	8/8/89	GYM	89-9741	<0.5	ST	N					Y		0	
23	Rock Creek	Elementary School	8/8/89	Cafeteria	89-9496	<0.5	ST	N					Y		0	
24	Terra Linda	Elementary School	8/8/89	GYM	89-9746	19.9	ST	Y	9/8/89	89-2669	1.8*	Improperly Sealed, 9/12/89, 89-1	Y	11/6/89 (GYM N/S) 89-	19.9	1.8
24	Terra Linda	Elementary School	8/8/89	2 GYM	89-19191	3.5	ST	N					Y		3.5	
24	Terra Linda	Elementary School	8/8/89	4 Library	89-20625	3.0	ST	N					Y		3.0	
24	Terra Linda	Elementary School	8/8/89	Classroom MU	89-9785	1.8	ST	N					Y		1.8	
24	Terra Linda	Elementary School	8/8/89	4 Library	89-2629	1.2	ST	N					Y		1.2	
24	Terra Linda	Elementary School	8/8/89	Classroom 2	89-12002	1.1	ST	N					Y		1.1	
24	Terra Linda	Elementary School	8/8/89	Classroom 11	89-11796	1.0	ST	N					Y		1.0	
24	Terra Linda	Elementary School	8/8/89	Classroom 5	89-11794	<0.5	ST	N					Y		0	
24	Terra Linda	Elementary School	8/8/89	Classroom 1B Café	89-9766	<0.5	ST	N					Y		0	
24	Terra Linda	Elementary School	8/8/89	Classroom 17	89-11795	<0.5	ST	N					Y		0	

2016 BSD Radon Sample Spreadsheet Database

Original Site #	Site Name	Facility Type	Test Date	Room Area Location	Sample Number	Result (pCi/l)	Test Type	Area Retested?	Test Date	Retested Sample #	Retested Sample Result (pCi/l)	Comments	Test Location on Floor Plan?	Misc	Result (value) (pCi/l)	Retested Sample Result (value) (pCi/l)
24	Terra Linda	Elementary School	8/8/89	Classroom 14	89-11734	<0.5	ST	N					Y		0	
24	Terra Linda	Elementary School	8/8/89	Classroom 8	89-4584	<0.5	ST	N					Y		0	
24	Terra Linda	Elementary School	8/8/89	Classroom 1B Café	89-20655	<0.5	ST	N					Y		0	
24	Terra Linda	Elementary School	8/8/89	Classroom MU	89-22255	<0.5	ST	N					Y		0	
25	Vose	Elementary School	8/8/89	Library	89-12643	4.1	ST	Y	11/6/89	89-18783	1.1	11/6/89, 89-24890, 1.7	Y	11/9/89 Lib n, 89-187	4.1	1.1
25	Vose	Elementary School	8/8/89	Classroom 12	89-22456	1.8	ST	N					Y		1.8	
25	Vose	Elementary School	8/8/89	Classroom 8	89-13791	1.7	ST	N					Y		1.7	
25	Vose	Elementary School	8/8/89	Classroom 7	89-19154	7.0	ST	N					Y		7.0	
25	Vose	Elementary School	8/8/89	Classroom 16	89-25528	<0.5	ST	N					Y		0	
25	Vose	Elementary School	8/8/89	Classroom 21	89-25406	<0.5	ST	N					Y		0	
25	Vose	Elementary School	8/8/89	Classroom 19	89-21892	<0.5	ST	N					Y		0	
25	Vose	Elementary School	8/8/89	Classroom 4	89-21593	<0.5	ST	N					Y		0	
25	Vose	Elementary School	8/8/89	Classroom 13	89-22241	<0.5	ST	N					Y		0	
25	Vose	Elementary School	8/8/89	Classroom 2	89-22457	<0.5	ST	N					Y		0	
25	Vose	Elementary School	8/8/89	Classroom 17	89-20675	<0.5	ST	N					Y		0	
25	Vose	Elementary School	8/8/89	Classroom 22	89-19111	<0.5	ST	N					Y		0	
25	Vose	Elementary School	8/8/89	Classroom 1	89-19299	<0.5	ST	N					Y		0	
25	Vose	Elementary School	8/8/89	Classroom 5	89-25492	<0.5	ST	N					Y		0	
25	Vose	Elementary School	8/8/89	Classroom 9	89-19460	<0.5	ST	N					Y		0	
25	Vose	Elementary School	8/8/89	Classroom 18	89-13811	<0.5	ST	N					Y		0	
25	Vose	Elementary School	8/8/89	Classroom 20	89-19135	<0.5	ST	N					Y		0	
25	Vose	Elementary School	8/8/89	Classroom 11	89-14299	<0.5	ST	N					Y		0	
25	Vose	Elementary School	8/8/89	Library	89-25779	<0.5	ST	N					Y		0	
25	Vose	Elementary School	8/8/89	Classroom 24	89-12641	<0.5	ST	N					Y		0	
25	Vose	Elementary School	8/8/89	Classroom 3	89-12666	<0.5	ST	N					Y		0	
25	Vose	Elementary School	8/8/89	Classroom 14	89-12664	<0.5	ST	N					Y		0	
25	Vose	Elementary School	8/8/89	Classroom 10	89-25782	<0.5	ST	N					Y		0	
25	Vose	Elementary School	8/8/89	Classroom MPR	89-22492	<0.5	ST	N					Y		0	
25	Vose	Elementary School	8/8/89	Classroom 15	89-14359	<0.5	ST	N					Y		0	
25	Vose	Elementary School	8/8/89	Cafeteria	89-25750	<0.5	ST	N					Y		0	
25	Vose	Elementary School	8/8/89	Classroom 23	89-24250	<0.5	ST	N					Y		0	
25	Vose	Elementary School	8/8/89	Classroom 6	89-12603	<0.5	ST	N					Y		0	
26	West Tualatin View	Elementary School	8/8/89	Classroom 4	89-12663	8.6	ST	Y	9/14/89	89-25730	2.1		Y		8.6	2.1
26	West Tualatin View	Elementary School	8/8/89	Classroom 5	89-14366	5.3	ST	Y	9/14/89	89-22372	2.8		Y		5.3	2.8
26	West Tualatin View	Elementary School	8/8/89	Cafeteria	89-12623	4.7	ST	Y	11/6/89	89-24832	<0.5		Y		4.7	0
26	West Tualatin View	Elementary School	8/8/89	Classroom 6	89-23688	4.4	ST	Y	11/6/89	89-19433	<0.5		Y		4.4	0
26	West Tualatin View	Elementary School	8/8/89	MPR GYM	89-23711	3.7	ST	N					Y		3.7	
26	West Tualatin View	Elementary School	8/8/89	Classroom ITIP	89-21649	1.1	ST	N					Y		1.1	
26	West Tualatin View	Elementary School	8/8/89	Classroom 2	89-23710	0.6	ST	N					Y		0.6	
26	West Tualatin View	Elementary School	8/8/89	Classroom 7	89-22371	<0.5	ST	N					Y		0	
26	West Tualatin View	Elementary School	8/8/89	Classroom 3	89-22379	<0.5	ST	N					Y		0	
26	West Tualatin View	Elementary School	8/8/89	MPR GYM	89-19415	<0.5	ST	N					Y		0	
26	West Tualatin View	Elementary School	8/8/89	Classroom 1	89-12649	<0.5	ST	N					Y		0	
27	William Walker	Elementary School	8/9/89	Library	89-12646	3.7	ST	N					Y		3.7	
27	William Walker	Elementary School	8/9/89	Classroom 4	89-21517	1.7	ST	N					Y		1.7	
27	William Walker	Elementary School	8/9/89	Classroom 11	89-19159	0.7	ST	N					Y		0.7	
27	William Walker	Elementary School	8/9/89	Classroom 3	89-24313	<0.5	ST	N					Y		0	
27	William Walker	Elementary School	8/9/89	Classroom 8	89-25087	<0.5	ST	N					Y		0	
27	William Walker	Elementary School	8/9/89	Classroom 20	89-13098	<0.5	ST	N					Y		0	
27	William Walker	Elementary School	8/9/89	Classroom 14	89-12616	<0.5	ST	N					Y		0	
27	William Walker	Elementary School	8/9/89	Classroom 5	89-13812	<0.5	ST	N					Y		0	
27	William Walker	Elementary School	8/9/89	Classroom 10	89-12598	<0.5	ST	N					Y		0	
27	William Walker	Elementary School	8/9/89	Classroom 6	89-12662	<0.5	ST	N					Y		0	
27	William Walker	Elementary School	8/9/89	Classroom 7	89-13944	<0.5	ST	N					Y		0	
27	William Walker	Elementary School	8/9/89	Classroom 13	89-12605	<0.5	ST	N					Y		0	
27	William Walker	Elementary School	8/9/89	Classroom 16	89-13875	<0.5	ST	N					Y		0	
27	William Walker	Elementary School	8/9/89	Classroom 17	89-21577	<0.5	ST	N					Y		0	
27	William Walker	Elementary School	8/9/89	Classroom 1	89-23014	<0.5	ST	N					Y		0	
27	William Walker	Elementary School	8/9/89	Classroom 9	89-1312	<0.5	ST	N					Y		0	
27	William Walker	Elementary School	8/9/89	Classroom 2	89-13837	<0.5	ST	N					Y		0	
27	William Walker	Elementary School	8/9/89	Classroom 18	89-18751	<0.5	ST	N					Y		0	
27	William Walker	Elementary School	8/9/89	Classroom 19	89-12626	<0.5	ST	N					Y		0	
27	William Walker	Elementary School	8/9/89	Cafeteria	89-12639	<0.5	ST	N					Y		0	
27	William Walker	Elementary School	8/9/89	Cafeteria	89-12599	<0.5	ST	N					Y		0	
27	William Walker	Elementary School	8/9/89	GYM	89-23469	<0.5	ST	N					Y		0	
27	William Walker	Elementary School	8/9/89	Classroom 15	89-4482	<0.5	ST	N					Y		0	
27	William Walker	Elementary School	8/9/89	Classroom 39	89-23484	<0.5	ST	N					Y		0	
27	William Walker	Elementary School	8/9/89	Classroom 26	89-12625	<0.5	ST	N					Y		0	
27	William Walker	Elementary School	8/9/89	Classroom 12	89-12602	<0.5	ST	N					Y		0	

2016 BSD Radon Sample Spreadsheet Database

Original Site #	Site Name	Facility Type	Test Date	Room Area Location	Sample Number	Result (pCi/l)	Test Type	Area Retested?	Test Date	Retested Sample #	Retested Sample Result (pCi/l)	Comments	Test Location on Floor Plan?	Misc	Result(value) (pCi/l)	Retested Sample Result (value) (pCi/l)
27	William Walker	Elementary School	8/9/89	Classroom 38	89-14567	<0.5	ST	N					Y		0	
27	William Walker	Elementary School	8/9/89	Classroom GYM	89-2364	<0.5	ST	N					Y		0	
28	Cedar Park	Middle School	8/9/89	Classroom Band	89-7818	3.8	ST	N					Y		3.8	
28	Cedar Park	Middle School	8/9/89	Classroom C15	89-7849	2.4	ST	N					Y		2.4	
28	Cedar Park	Middle School	8/9/89	Classroom GYM	89-12658	2.2	ST	N					Y		2.2	
28	Cedar Park	Middle School	8/9/89	Classroom B3	89-12644	2.1	ST	N					Y		2.1	
28	Cedar Park	Middle School	8/9/89	Classroom A14	89-10860	1.7	ST	N					Y		1.7	
28	Cedar Park	Middle School	8/9/89	Classroom GYM	89-6901	1.3	ST	N					Y		1.3	
28	Cedar Park	Middle School	8/9/89	Classroom C14	89-12678	1.1	ST	N					Y		1.1	
28	Cedar Park	Middle School	8/9/89	Classroom C12	89-2970	1.1	ST	N					Y		1.1	
28	Cedar Park	Middle School	8/9/89	Classroom C6	89-14336	0.8	ST	N					Y		0.8	
28	Cedar Park	Middle School	8/9/89	Library	89-12328	0.8	ST	N					Y		0.8	
28	Cedar Park	Middle School	8/9/89	Cafeteria	89-16456	0.6	ST	N					Y		0.6	
28	Cedar Park	Middle School	8/9/89	Classroom A4	89-2983	<0.5	ST	N					Y		0	
28	Cedar Park	Middle School	8/9/89	Classroom A7	89-6284	<0.5	ST	N					Y		0	
28	Cedar Park	Middle School	8/9/89	Classroom A12	89-23785	<0.5	ST	N					Y		0	
28	Cedar Park	Middle School	8/9/89	Classroom C10	89-23482	<0.5	ST	N					Y		0	
28	Cedar Park	Middle School	8/9/89	Classroom B6	89-12621	<0.5	ST	N					Y		0	
28	Cedar Park	Middle School	8/9/89	Classroom A3	89-22488	<0.5	ST	N					Y		0	
28	Cedar Park	Middle School	8/9/89	Classroom B5	89-7859	<0.5	ST	N					Y		0	
28	Cedar Park	Middle School	8/9/89	Classroom B14	89-6923	<0.5	ST	N					Y	s	0	
28	Cedar Park	Middle School	8/9/89	Classroom B2	89-6914	<0.5	ST	N					Y	s	0	
28	Cedar Park	Middle School	8/9/89	Classroom C3	89-7834	<0.5	ST	N					Y	s	0	
28	Cedar Park	Middle School	8/9/89	Classroom C13	89-6283	<0.5	ST	N					Y	s	0	
28	Cedar Park	Middle School	8/9/89	Classroom A6	89-8955	<0.5	ST	N					Y	s	0	
28	Cedar Park	Middle School	8/9/89	Classroom B10/B12	89-8925	<0.5	ST	N					Y		0	
28	Cedar Park	Middle School	8/9/89	Classroom A10	89-2982	<0.5	ST	N					Y		0	
28	Cedar Park	Middle School	8/9/89	Classroom B1	89-16849	<0.5	ST	N					Y		0	
28	Cedar Park	Middle School	8/9/89	Library	89-6921	<0.5	ST	N					Y		0	
28	Cedar Park	Middle School	8/9/89	Classroom C1	89-22429	<0.5	ST	N					Y		0	
28	Cedar Park	Middle School	8/9/89	Classroom B9	89-2945	<0.5	ST	N					Y		0	
28	Cedar Park	Middle School	8/9/89	Classroom B8	89-10875	<0.5	ST	N					Y		0	
28	Cedar Park	Middle School	8/9/89	Classroom A11	89-6978	<0.5	ST	N					Y		0	
28	Cedar Park	Middle School	8/9/89	Classroom C5	89-2972	<0.5	ST	N					Y		0	
28	Cedar Park	Middle School	8/9/89	Classroom B4	89-13874	<0.5	ST	N					Y		0	
28	Cedar Park	Middle School	8/9/89	Classroom A8	89-7819	<0.5	ST	N					Y		0	
28	Cedar Park	Middle School	8/9/89	Classroom C7	89-2989	<0.5	ST	N					Y		0	
28	Cedar Park	Middle School	8/9/89	Classroom C4/C2	89-12630	<0.5	ST	N					Y		0	
28	Cedar Park	Middle School	8/9/89	Classroom C8	89-13926	<0.5	ST	N					Y		0	
28	Cedar Park	Middle School	8/9/89	Classroom A5	89-8939	<0.5	ST	N					Y		0	
28	Cedar Park	Middle School	8/9/89	Classroom A9	89-6285	<0.5	ST	N					Y		0	
28	Cedar Park	Middle School	8/9/89	Classroom C11	89-24254	<0.5	ST	N					Y		0	
28	Cedar Park	Middle School	8/9/89	Classroom B7	89-12648	<0.5	ST	N					Y		0	
28	Cedar Park	Middle School	8/9/89	Cafeteria	89-23448	<0.5	ST	N					Y		0	
29	Five Oaks	Middle School	8/9/89	Classroom 18	89-3411	3.4	ST	N					Y		3.4	
29	Five Oaks	Middle School	8/9/89	Classroom 22	89-4833	2.4	ST	N					Y		2.4	
29	Five Oaks	Middle School	8/9/89	Classroom 12	89-4488	2.3	ST	N					Y		2.3	
29	Five Oaks	Middle School	8/9/89	Classroom C1	89-8942	2.0	ST	N					Y		2.0	
29	Five Oaks	Middle School	8/9/89	Classroom 15B	89-4980	1.8	ST	N					Y		1.8	
29	Five Oaks	Middle School	8/9/89	Classroom S1	89-10834	1.6	ST	N					Y		1.6	
29	Five Oaks	Middle School	8/9/89	Classroom 15A	89-9478	1.4	ST	N					Y		1.4	
29	Five Oaks	Middle School	8/9/89	Classroom 24	89-9782	1.2	ST	N					Y		1.2	
29	Five Oaks	Middle School	8/9/89	Classroom 16	89-8958	0.7	ST	N					Y		0.7	
29	Five Oaks	Middle School	8/9/89	Classroom F3	89-16812	0.7	ST	N					Y		0.7	
29	Five Oaks	Middle School	8/9/89	Classroom 40	89-8965	<0.5	ST	N					Y		0	
29	Five Oaks	Middle School	8/9/89	Classroom E2	89-8959	<0.5	ST	N					Y		0	
29	Five Oaks	Middle School	8/9/89	Classroom D4	89-10893	<0.5	ST	N					Y		0	
29	Five Oaks	Middle School	8/9/89	Classroom 29	89-1329	<0.5	ST	N					Y		0	
29	Five Oaks	Middle School	8/9/89	Classroom 53	89-2981	<0.5	ST	N					Y		0	
29	Five Oaks	Middle School	8/9/89	Classroom 20	89-4987	<0.5	ST	N					Y		0	
29	Five Oaks	Middle School	8/9/89	Classroom B2	89-7807	<0.5	ST	N					Y		0	
29	Five Oaks	Middle School	8/9/89	Classroom B4	89-16438	<0.5	ST	N					Y		0	
29	Five Oaks	Middle School	8/9/89	Classroom 39	89-3410	<0.5	ST	N					Y		0	
29	Five Oaks	Middle School	8/9/89	Classroom IMCC	89-13528	<0.5	ST	N					Y		0	
29	Five Oaks	Middle School	8/9/89	Classroom 19	89-16829	<0.5	ST	N					Y		0	
29	Five Oaks	Middle School	8/9/89	Classroom E4	89-16811	<0.5	ST	N					Y		0	
29	Five Oaks	Middle School	8/9/89	Classroom IMCA	89-10866	<0.5	ST	N					Y		0	
29	Five Oaks	Middle School	8/9/89	Classroom AB2	89-6297	<0.5	ST	N					Y		0	
29	Five Oaks	Middle School	8/9/89	Classroom B1	89-16460	<0.5	ST	N					Y		0	

2016 BSD Radon Sample Spreadsheet Database

Original Site #	Site Name	Facility Type	Test Date	Room Area Location	Sample Number	Result (pCi/l)	Test Type	Area Retested?	Test Date	Retested Sample #	Retested Sample Result (pCi/l)	Comments	Test Location on Floor Plan?	Misc	Result(value) (pCi/l)	Retested Sample Result (value) (pCi/l)
29	Five Oaks	Middle School	8/9/89	Classroom 30	89-2641	<0.5	ST	N					Y		0	
29	Five Oaks	Middle School	8/9/89	Classroom C4/C2	89-7839	<0.5	ST	N					Y		0	
29	Five Oaks	Middle School	8/9/89	Classroom 36	89-6648	<0.5*	ST	N				Improperly Sealed	Y		0	
29	Five Oaks	Middle School	8/9/89	Classroom C2	89-3461	<0.5	ST	N					Y		0	
29	Five Oaks	Middle School	8/9/89	Classroom 15C	89-1832	<0.5	ST	N					Y		0	
29	Five Oaks	Middle School	8/9/89	Classroom S4	89-8953	<0.5	ST	N					Y		0	
29	Five Oaks	Middle School	8/9/89	Classroom D1	89-7810	<0.5	ST	N					Y		0	
29	Five Oaks	Middle School	8/9/89	Classroom S2W	89-6942	<0.5	ST	N					Y		0	
29	Five Oaks	Middle School	8/9/89	Classroom F1	89-6922	<0.5	ST	N					Y		0	
29	Five Oaks	Middle School	8/9/89	Classroom A1	89-10892	<0.5	ST	N					Y		0	
29	Five Oaks	Middle School	8/9/89	Classroom IMCB	89-10156	<0.5	ST	N					Y		0	
30	Highland Park	Middle School	8/9/89	C15	89-8949	<0.5	ST	N					Y		0	
30	Highland Park	Middle School	8/9/89	C25	89-13779	<0.5	ST	N					Y		0	
30	Highland Park	Middle School	8/9/89	Library	89-12604	<0.5	ST	N					Y		0	
30	Highland Park	Middle School	8/9/89	C2	89-8924	<0.5	ST	N					Y		0	
30	Highland Park	Middle School	8/9/89	Cafeteria	89-22462	<0.5	ST	N					Y		0	
30	Highland Park	Middle School	8/9/89	C25	89-13807	<0.5	ST	N					Y		0	
30	Highland Park	Middle School	8/9/89	A11	89-3460	<0.5	ST	N					Y		0	
30	Highland Park	Middle School	8/9/89	B6	89-8936	<0.5	ST	N					Y		0	
30	Highland Park	Middle School	8/9/89	A6	89-13503	<0.5	ST	N					Y		0	
30	Highland Park	Middle School	8/9/89	C14	89-8432	3.3	ST	N					Y		3.3	
30	Highland Park	Middle School	8/9/89	A8	89-7850	2.7	ST	N					Y		2.7	
30	Highland Park	Middle School	8/9/89	A16	89-10865	2.1	ST	N					Y		2.1	
30	Highland Park	Middle School	8/9/89	C1	89-6639	2.1	ST	N					Y		2.1	
30	Highland Park	Middle School	8/9/89	B14	89-8946	1.6	ST	N					Y		1.6	
30	Highland Park	Middle School	8/9/89	C11	89-14367	1.6	ST	N					Y		1.6	
30	Highland Park	Middle School	8/9/89	B3	89-17533	1.6	ST	N					Y		1.6	
30	Highland Park	Middle School	8/9/89	C8	89-6586	1.4	ST	N					Y		1.4	
30	Highland Park	Middle School	8/9/89	B10	89-8957	1.4	ST	N					Y		1.4	
30	Highland Park	Middle School	8/9/89	Cafeteria	89-4712	1.0	ST	N					Y		1.0	
30	Highland Park	Middle School	8/9/89	C10	89-6920	1.0	ST	N					Y		1.0	
30	Highland Park	Middle School	8/9/89	B9	89-8935	0.9	ST	N					Y		0.9	
30	Highland Park	Middle School	8/9/89	A12	89-6940	<0.5	ST	N					Y		0	
30	Highland Park	Middle School	8/9/89	B8	89-8952	<0.5	ST	N					Y		0	
30	Highland Park	Middle School	8/9/89	C5	89-16414	<0.5	ST	N					Y		0	
30	Highland Park	Middle School	8/9/89	A1	89-22481	<0.5	ST	N					Y		0	
30	Highland Park	Middle School	8/9/89	C7	89-20582	<0.5	ST	N					Y		0	
30	Highland Park	Middle School	8/9/89	C6	89-12642	<0.5	ST	N					Y		0	
30	Highland Park	Middle School	8/9/89	A5	89-7855	<0.5	ST	N					Y		0	
30	Highland Park	Middle School	8/9/89	C12	89-7835	<0.5	ST	N					Y		0	
30	Highland Park	Middle School	8/9/89	B7	89-6997	<0.5	ST	N					Y		0	
30	Highland Park	Middle School	8/9/89	C4	89-12167	<0.5	ST	N					Y		0	
30	Highland Park	Middle School	8/9/89	A4	89-10613	<0.5	ST	N					Y		0	
30	Highland Park	Middle School	8/9/89	C3	89-12610	<0.5	ST	N					Y		0	
30	Highland Park	Middle School	8/9/89	B4	89-23661	<0.5	ST	N					Y		0	
30	Highland Park	Middle School	8/9/89	A14	89-3430	<0.5	ST	N					Y		0	
30	Highland Park	Middle School	8/9/89	A9	89-13552	<0.5	ST	N					Y		0	
30	Highland Park	Middle School	8/9/89	C13	89-10845	<0.5	ST	N					Y		0	
30	Highland Park	Middle School	8/9/89	A10	89-13857	<0.5	ST	N					Y		0	
30	Highland Park	Middle School	8/9/89	A2	89-22455	<0.5	ST	N					Y		0	
30	Highland Park	Middle School	8/9/89	B5	89-1816	<0.5	ST	N					Y		0	
30	Highland Park	Middle School	8/9/89	A7	89-10840	<0.5	ST	N					Y		0	
31	Meadow Park	Middle School	8/9/89	C10	89-13799	22.4	ST	Y	9/14/89	89-4969	<0.5*	10/13/89, 89-23779, <0.5	Y	10/26/89, 89-6755, <0.5	22.4	0
31	Meadow Park	Middle School	8/9/89	C2	89-12650	5.5	ST	Y	9/12/89	89-6630	<0.5*		Y	10/26/89, 89-10931, <0.5	5.5	0
31	Meadow Park	Middle School	8/9/89	C6	89-8436	5.1	ST	Y	9/8/89	89-6593	1.1*		Y	10/26/89, 89-22714, <0.5	5.1	1.1
31	Meadow Park	Middle School	8/9/89	B11	89-7004	3.7	ST	N					Y		3.7	
31	Meadow Park	Middle School	8/9/89	B15	89-12617	2.5	ST	N					Y		2.5	
31	Meadow Park	Middle School	8/9/89	A7	89-11212	1.6	ST	N					Y		1.6	
31	Meadow Park	Middle School	8/9/89	B6	89-6651	1.5	ST	N					Y		1.5	
31	Meadow Park	Middle School	8/9/89	B15	89-14380	1.4	ST	N					Y		1.4	
31	Meadow Park	Middle School	8/9/89	A17	89-12629	1.3	ST	N					Y		1.3	
31	Meadow Park	Middle School	8/9/89	C3	89-17532	1.3	ST	N					Y		1.3	
31	Meadow Park	Middle School	8/9/89	C8	89-12640	1.2	ST	N					Y		1.2	
31	Meadow Park	Middle School	8/9/89	A13	89-6589	1.1	ST	N					Y		1.1	
31	Meadow Park	Middle School	8/9/89	B11	89-12635	1.0	ST	N					Y		1.0	
31	Meadow Park	Middle School	8/9/89	LB10	89-13147	0.9	ST	N					Y		0.9	
31	Meadow Park	Middle School	8/9/89	C1	89-12682	<0.5	ST	N					Y		0	
31	Meadow Park	Middle School	8/9/89	B12	89-12600	<0.5	ST	N					Y		0	
31	Meadow Park	Middle School	8/9/89	C13	89-23690	<0.5	ST	N					Y		0	

2016 BSD Radon Sample Spreadsheet Database

Original Site #	Site Name	Facility Type	Test Date	Room Area Location	Sample Number	Result (pCi/l)	Test Type	Area Retested?	Test Date	Retested Sample #	Retested Sample Result (pCi/l)	Comments	Test Location on Floor Plan?	Misc	Result (value) (pCi/l)	Retested Sample Result (value) (pCi/l)
31	Meadow Park	Middle School	8/9/89	A11	89-7007	<0.5	ST	N					Y		0	
31	Meadow Park	Middle School	8/9/89	B2	89-25979	<0.5	ST	N					Y		0	
31	Meadow Park	Middle School	8/9/89	B8	89-12297	<0.5	ST	N					Y		0	
31	Meadow Park	Middle School	8/9/89	A3	89-8448	<0.5	ST	N					Y		0	
31	Meadow Park	Middle School	8/9/89	B5	89-20594	<0.5	ST	N					Y		0	
31	Meadow Park	Middle School	8/9/89	B14	89-6628	<0.5	ST	N					Y		0	
31	Meadow Park	Middle School	8/9/89	B3	89-15641	<0.5	ST	N					Y		0	
31	Meadow Park	Middle School	8/9/89	B9	89-12687	<0.5	ST	N					Y		0	
31	Meadow Park	Middle School	8/9/89	B7	89-11231	<0.5	ST	N					Y		0	
31	Meadow Park	Middle School	8/9/89	B1	89-16356	<0.5	ST	N					Y		0	
31	Meadow Park	Middle School	8/9/89	A21	89-6657	<0.5	ST	N					Y		0	
31	Meadow Park	Middle School	8/9/89	A5	89-1833	<0.5	ST	N					Y		0	
31	Meadow Park	Middle School	8/9/89	A4	89-22116	<0.5	ST	N					Y		0	
31	Meadow Park	Middle School	8/9/89	C5	89-25946	<0.5	ST	N					Y		0	
31	Meadow Park	Middle School	8/9/89	B4	89-17531	<0.5	ST	N					Y		0	
31	Meadow Park	Middle School	8/9/89	C9	89-12620	<0.5	ST	N					Y		0	
31	Meadow Park	Middle School	8/9/89	C15	89-22232	<0.5	ST	N					Y		0	
31	Meadow Park	Middle School	8/9/89	A15	89-4316	<0.5	ST	N					Y		0	
31	Meadow Park	Middle School	8/9/89	A10	89-12628	<0.5	ST	N					Y		0	
31	Meadow Park	Middle School	8/9/89	A21	89-17530	<0.5	ST	N					Y		0	
31	Meadow Park	Middle School	8/9/89	A6	89-12607	<0.5	ST	N					Y		0	
31	Meadow Park	Middle School	8/9/89	A8	89-17528	<0.5	ST	N					Y		0	
31	Meadow Park	Middle School	8/9/89	A9	89-13036	<0.5	ST	N					Y		0	
31	Meadow Park	Middle School	8/9/89	C12	89-13093	<0.5	ST	N					Y		0	
31	Meadow Park	Middle School	8/9/89	C11	89-17285	<0.5	ST	N					Y		0	
32	Mountain View	Middle School	8/9/89	D6/D8	89-18756	6.6	ST	Y	9/14/89	89-7471	0.6		Y		6.6	0.6
32	Mountain View	Middle School	8/9/89	D0	89-12231	3.0	ST	N					Y		3.0	
32	Mountain View	Middle School	8/9/89	C10	89-21464	3.0	ST	N					Y		3.0	
32	Mountain View	Middle School	8/9/89	A9	89-22863	2.8	ST	N					Y		2.8	
32	Mountain View	Middle School	8/9/89	A17	89-11220	2.5	ST	N					Y		2.5	
32	Mountain View	Middle School	8/9/89	A21	89-25944	2.4	ST	N					Y		2.4	
32	Mountain View	Middle School	8/9/89	B10	89-11236	2.4	ST	N					Y		2.4	
32	Mountain View	Middle School	8/9/89	A19	89-8294	2.0	ST	N					Y		2.0	
32	Mountain View	Middle School	8/9/89	C3	89-12214	1.9	ST	N					Y		1.9	
32	Mountain View	Middle School	8/9/89	A28	89-14382	1.9	ST	N					Y		1.9	
32	Mountain View	Middle School	8/9/89	C7	89-6638	1.9	ST	N					Y		1.9	
32	Mountain View	Middle School	8/9/89	A7	89-24809	1.7	ST	N					Y		1.7	
32	Mountain View	Middle School	8/9/89	A17	89-6635	1.6	ST	N					Y		1.6	
32	Mountain View	Middle School	8/9/89	C11	89-8720	1.5	ST	N					Y		1.5	
32	Mountain View	Middle School	8/9/89	A1/A3	89-17593	1.5	ST	N					Y		1.5	
32	Mountain View	Middle School	8/9/89	D11/D13	89-2620	1.4	ST	N					Y		1.4	
32	Mountain View	Middle School	8/9/89	B12/C12	89-11239	1.1	ST	N					Y		1.1	
32	Mountain View	Middle School	8/9/89	A11	89-21444	1.1	ST	N					Y		1.1	
32	Mountain View	Middle School	8/9/89	B11	89-12651	1.0	ST	N					Y		1.0	
32	Mountain View	Middle School	8/9/89	C2	89-2603	1.0	ST	N					Y		1.0	
32	Mountain View	Middle School	8/9/89	A2	89-20374	1.0	ST	N					Y		1.0	
32	Mountain View	Middle School	8/9/89	D7	89-25939	0.9	ST	N					Y		0.9	
32	Mountain View	Middle School	8/9/89	B2/B4	89-118117	0.8	ST	N					Y		0.8	
32	Mountain View	Middle School	8/9/89	C6	89-20499	0.8	ST	N					Y		0.8	
32	Mountain View	Middle School	8/9/89	C4	89-21563	0.7	ST	N					Y		0.7	
32	Mountain View	Middle School	8/9/89	E5	89-18135	0.6	ST	N					Y		0.6	
32	Mountain View	Middle School	8/9/89	E1	89-15527	0.6	ST	N					Y		0.6	
32	Mountain View	Middle School	8/9/89	D15	89-23254	<0.5	ST	N					Y		0	
32	Mountain View	Middle School	8/9/89	E0	89-21491	<0.5	ST	N					Y		0	
32	Mountain View	Middle School	8/9/89	A4/B7	89-22750	<0.5	ST	N					Y		0	
32	Mountain View	Middle School	8/9/89	C5	89-13141	<0.5	ST	N					Y		0	
32	Mountain View	Middle School	8/9/89	C8	89-12246	<0.5	ST	N					Y		0	
32	Mountain View	Middle School	8/9/89	D21/D4	89-2633	<0.5	ST	N					Y		0	
32	Mountain View	Middle School	8/9/89	E5	89-2671	<0.5	ST	N					Y		0	
32	Mountain View	Middle School	8/9/89	C1	89-13118	<0.5	ST	N					Y		0	
32	Mountain View	Middle School	8/9/89	AG	89-15642	<0.5	ST	N					Y		0	
32	Mountain View	Middle School	8/9/89	A15	89-18108	<0.5	ST	N					Y		0	
32	Mountain View	Middle School	8/9/89	A13	89-22718	<0.5	ST	N					Y		0	
32	Mountain View	Middle School	8/9/89	E1	89-12677	<0.5	ST	N					Y		0	
33	Whitford	Middle School	8/9/89	17	89-19482	4.8	ST	Y	11/6/89	89-24825	1.1	89-18723, 0.6	Y		4.8	1.1
33	Whitford	Middle School	8/9/89	A9	89-23781	4.2	ST	Y	11/6/89	89-25465	1.8		Y		4.2	1.8
33	Whitford	Middle School	8/9/89	10A	89-12694	1.4	ST	N					Y		1.4	
33	Whitford	Middle School	8/9/89	10A	89-19471	1.4	ST	N					Y		1.4	
33	Whitford	Middle School	8/9/89	B12	89-19440	1.2	ST	N					Y		1.2	

2016 BSD Radon Sample Spreadsheet Database

Original Site #	Site Name	Facility Type	Test Date	Room Area Location	Sample Number	Result (pCi/l)	Test Type	Area Retested?	Test Date	Retested Sample #	Retested Sample Result (pCi/l)	Comments	Test Location on Floor Plan?	Misc	Result(value) (pCi/l)	Retested Sample Result (value) (pCi/l)
33	Whitford	Middle School	8/9/89	A5	89-7832	0.7	ST	N					Y		0.7	
33	Whitford	Middle School	8/9/89	17	89-19449	0.7	ST	N					Y		0.7	
33	Whitford	Middle School	8/9/89	C5	89-22731	<0.5	ST	N					Y		0	
33	Whitford	Middle School	8/9/89	B4	89-20540	<0.5	ST	N					Y		0	
33	Whitford	Middle School	8/9/89	A7	89-25414	<0.5	ST	N					Y		0	
33	Whitford	Middle School	8/9/89	C13	89-7442	<0.5	ST	N					Y		0	
33	Whitford	Middle School	8/9/89	C11	89-12676	<0.5	ST	N					Y		0	
33	Whitford	Middle School	8/9/89	B10	89-8289	<0.5	ST	N					Y		0	
33	Whitford	Middle School	8/9/89	C10	89-22198	<0.5	ST	N					Y		0	
33	Whitford	Middle School	8/9/89	B9	89-22757	<0.5	ST	N					Y		0	
33	Whitford	Middle School	8/9/89	A2	89-18781	<0.5	ST	N					Y		0	
33	Whitford	Middle School	8/9/89	B1	89-23654	<0.5	ST	N					Y		0	
33	Whitford	Middle School	8/9/89	20	89-12631	<0.5	ST	N					Y		0	
33	Whitford	Middle School	8/9/89	B6	89-3323	<0.5	ST	N					Y		0	
33	Whitford	Middle School	8/9/89	C1	89-19156	<0.5	ST	N					Y		0	
33	Whitford	Middle School	8/9/89	A8	89-25704	<0.5	ST	N					Y		0	
33	Whitford	Middle School	8/9/89	B8	89-6223	<0.5	ST	N					Y		0	
33	Whitford	Middle School	8/9/89	C9	89-23031	<0.5	ST	N					Y		0	
33	Whitford	Middle School	8/9/89	B5	89-23095	<0.5	ST	N					Y		0	
33	Whitford	Middle School	8/9/89	24	89-25403	<0.5	ST	N					Y		0	
33	Whitford	Middle School	8/9/89	B14	89-21790	<0.5	ST	N					Y		0	
33	Whitford	Middle School	8/9/89	20	89-22197	<0.5	ST	N					Y		0	
33	Whitford	Middle School	8/9/89	C6	89-13910	<0.5	ST	N					Y		0	
33	Whitford	Middle School	8/9/89	C15	89-1819	<0.5	ST	N					Y		0	
33	Whitford	Middle School	8/9/89	A6	89-23239	<0.5	ST	N					Y		0	
33	Whitford	Middle School	8/9/89	B3	89-22572	<0.5	ST	N					Y		0	
33	Whitford	Middle School	8/9/89	C8	89-18718	<0.5	ST	N					Y		0	
33	Whitford	Middle School	8/9/89	A15	89-2628	<0.5	ST	N					Y		0	
33	Whitford	Middle School	8/9/89	B7	89-23648	<0.5	ST	N					Y		0	
33	Whitford	Middle School	8/9/89	C7	89-24820	<0.5	ST	N					Y		0	
33	Whitford	Middle School	8/9/89	B2	89-7489	<0.5	ST	N					Y		0	
33	Whitford	Middle School	8/9/89	A13	89-20513	<0.5	ST	N					Y		0	
33	Whitford	Middle School	8/9/89	A4	89-7485	<0.5	ST	N					Y		0	
33	Whitford	Middle School	8/9/89	A11	89-18171	<0.5	ST	N					Y		0	
33	Whitford	Middle School	8/9/89	A1/3	89-21591	<0.5	ST	N					Y		0	
33	Whitford	Middle School	8/9/89	C12	89-25496	<0.5	ST	N					Y		0	
33	Whitford	Middle School	8/9/89	C3/4	89-12653	<0.5	ST	N					Y		0	
33	Whitford	Middle School	8/9/89	A10	89-22278	<0.5	ST	N					Y		0	
33	Whitford	Middle School	8/9/89	13	89-8840	<0.5	ST	N					Y		0	
34	Aloha	High School	8/8/89	J-1	89-14928	9.9	ST	Y	9/11/89	89-2645	4.5	11/20/89, 89-23281, 4.8	Y		9.9	4.5
34	Aloha	High School	8/8/89	J-2	8919432	7.9	ST	Y	9/11/89	89-2670	3.0		Y		7.9	3.0
34	Aloha	High School	8/8/89	Cafeteria 2	89-19464	6.6	ST	Y	9/11/89	89-25438	3.5		Y		6.6	3.5
34	Aloha	High School	8/8/89	Cafeteria 2	89-6678	4.3	ST	Y	9/11/89	89-2640	3.2		Y		4.3	3.2
34	Aloha	High School	8/8/89	A	89-6652	3.8	ST	N					Y		3.8	
34	Aloha	High School	8/8/89	D-3	89-19580	3.7	ST	N					Y		3.7	
34	Aloha	High School	8/8/89	D-1	89-17191	2.7	ST	N					Y		2.7	
34	Aloha	High School	8/8/89	F-13	89-17270	2.3	ST	N					Y		2.3	
34	Aloha	High School	8/8/89	IMC 2	89-15667	2.1	ST	N					Y		2.1	
34	Aloha	High School	8/8/89	C-8	89-2691	2.1	ST	N					Y		2.1	
34	Aloha	High School	8/8/89	E-17	89-6672	1.6	ST	N					Y		1.6	
34	Aloha	High School	8/8/89	F-6	89-12257	1.1	ST	N					Y		1.1	
34	Aloha	High School	8/8/89	AUD 2	89-12014	1.0	ST	N					Y		1.0	
34	Aloha	High School	8/8/89	E-26	89-12265	1.0	ST	N					Y		1.0	
34	Aloha	High School	8/8/89	E-1	89-12654	0.9	ST	N					Y		0.9	
34	Aloha	High School	8/8/89	G-12	89-1314	0.8	ST	N					Y		0.8	
34	Aloha	High School	8/8/89	Weight Room	89-12004	0.8	ST	N					Y		0.8	
34	Aloha	High School	8/8/89	A-14	89-11707	0.7	ST	N					Y		0.7	
34	Aloha	High School	8/8/89	F15	89-20446	0.7	ST	N					Y		0.7	
34	Aloha	High School	8/8/89	E-2	89-15535	0.6	ST	N					Y		0.6	
34	Aloha	High School	8/8/89	F-2	89-8414	0.6	ST	N					Y		0.6	
34	Aloha	High School	8/8/89	E-15	89-6632	<0.5	ST	N					Y		0	
34	Aloha	High School	8/8/89	E-16	89-7468	<0.5	ST	N					Y		0	
34	Aloha	High School	8/8/89	C-10	89-21433	<0.5	ST	N					Y		0	
34	Aloha	High School	8/8/89	A-2	89-15789	<0.5	ST	N					Y		0	
34	Aloha	High School	8/8/89	W rest 1	89-13401	<0.5	ST	N					Y		0	
34	Aloha	High School	8/8/89	E-8	89-11291	<0.5	ST	N					Y		0	
34	Aloha	High School	8/8/89	H-14	89-2690	<0.5	ST	N					Y		0	
34	Aloha	High School	8/8/89	E-6	89-17554	<0.5	ST	N					Y		0	
34	Aloha	High School	8/8/89	E-14	89-20534	<0.5	ST	N					Y		0	

2016 BSD Radon Sample Spreadsheet Database

Original Site #	Site Name	Facility Type	Test Date	Room Area Location	Sample Number	Result (pCi/l)	Test Type	Area Retested?	Test Date	Retested Sample #	Retested Sample Result (pCi/l)	Comments	Test Location on Floor Plan?	Misc	Result(value) (pCi/l)	Retested Sample Result (value) (pCi/l)
34	Aloha	High School	8/8/89	E-4	89-17249	<0.5	ST	N					Y		0	
34	Aloha	High School	8/8/89	A-4	89-17295	<0.5	ST	N					Y		0	
34	Aloha	High School	8/8/89	E-1	89-15533	<0.5	ST	N					Y		0	
34	Aloha	High School	8/8/89	A-10	89-8412	<0.5	ST	N					Y		0	
34	Aloha	High School	8/8/89	J-3	89-19540	<0.5	ST	N					Y		0	
34	Aloha	High School	8/8/89	IMC 3	89-2144+9	<0.5	ST	N					Y		0	
34	Aloha	High School	8/8/89	F8	89-19946	<0.5	ST	N					Y		0	
34	Aloha	High School	8/8/89	E20	89-16047	<0.5	ST	N					Y		0	
34	Aloha	High School	8/8/89	E24	89-16384	<0.5	ST	N					Y		0	
34	Aloha	High School	8/8/89	C9	89-22753	<0.5	ST	N					Y		0	
34	Aloha	High School	8/8/89	G10	89-4852	<0.5	ST	N					Y		0	
34	Aloha	High School	8/8/89	AUD 1	89-21469	<0.5	ST	N					Y		0	
34	Aloha	High School	8/8/89	F11	89-6611	<0.5	ST	N					Y		0	
34	Aloha	High School	8/8/89	C7	89-2689	<0.5	ST	N					Y		0	
34	Aloha	High School	8/8/89	H13	89-16329	<0.5	ST	N					Y		0	
34	Aloha	High School	8/8/89	A12	89-15525	<0.5	ST	N					Y		0	
34	Aloha	High School	8/8/89	H10	89-16339	<0.5	ST	N					Y		0	
34	Aloha	High School	8/8/89	E18	89-21789	<0.5	ST	N					Y		0	
34	Aloha	High School	8/8/89	E7	89-17289	<0.5	ST	N					Y		0	
34	Aloha	High School	8/8/89	E22	89-2668	<0.5	ST	N					Y		0	
34	Aloha	High School	8/8/89	G13	89-6650	<0.5	ST	N					Y		0	
34	Aloha	High School	8/8/89	F1	89-12094	<0.5	ST	N					Y		0	
34	Aloha	High School	8/8/89	W rest 2	89-21597	<0.5	ST	N					Y		0	
34	Aloha	High School	8/8/89	E9	89-7831	<0.5	ST	N					Y		0	
34	Aloha	High School	8/8/89	Gallery	89-7003	<0.5	ST	N					Y		0	
34	Aloha	High School	8/8/89	F10	89-23129	<0.5	ST	N					Y		0	
34	Aloha	High School	8/8/89	G11	89-25461	<0.5	ST	N					Y		0	
34	Aloha	High School	8/8/89	F12	89-17575	<0.5	ST	N					Y		0	
34	Aloha	High School	8/8/89	E13	89-4828	<0.5	ST	N					Y		0	
35	Beaverton	High School	8/9/89	159	89-17529	1.1	ST	N					Y		1.1	
35	Beaverton	High School	8/9/89	106	89-20577	1.1	ST	N					Y		1.1	
35	Beaverton	High School	8/9/89	102	89-11292	0.7	ST	N					Y		0.7	
35	Beaverton	High School	8/9/89	123N	89-17535	<0.5*	ST	N				Improperly Sealed	Y		0	
35	Beaverton	High School	8/9/89	142	89-11246	<0.5	ST	N					Y		0	
35	Beaverton	High School	8/9/89	---	89-22280	<0.5	ST	N					Y		0	
35	Beaverton	High School	8/9/89	Audit S	89-17227	<0.5	ST	N					Y		0	
35	Beaverton	High School	8/9/89	109	89-15786	<0.5	ST	N					Y		0	
35	Beaverton	High School	8/9/89	140	89-15886	<0.5	ST	N					Y		0	
35	Beaverton	High School	8/9/89	113	89-17272	<0.5	ST	N					Y		0	
35	Beaverton	High School	8/9/89	Audit	89-17192	<0.5	ST	N					Y		0	
35	Beaverton	High School	8/9/89	157S	89-15577	<0.5	ST	N					Y		0	
35	Beaverton	High School	8/9/89	137	89-14599	<0.5	ST	N					Y		0	
35	Beaverton	High School	8/9/89	135	89-8422	<0.5	ST	N					Y		0	
35	Beaverton	High School	8/9/89	Weight Room	89-6679	<0.5	ST	N					Y		0	
35	Beaverton	High School	8/9/89	115	89-17534	<0.5	ST	N					Y		0	
35	Beaverton	High School	8/9/89	111	89-11296	<0.5	ST	N					Y		0	
35	Beaverton	High School	8/9/89	104	89-11290	<0.5	ST	N					Y		0	
35	Beaverton	High School	8/9/89	108	89-22257	<0.5	ST	N					Y		0	
35	Beaverton	High School	8/9/89	133	89-7000	<0.5	ST	N					Y		0	
35	Beaverton	High School	8/9/89	Lib E	89-20603	<0.5	ST	N					Y		0	
35	Beaverton	High School	8/9/89	110	89-16247	<0.5	ST	N					Y		0	
35	Beaverton	High School	8/9/89	38	89-20960	<0.5	ST	N					Y		0	
35	Beaverton	High School	8/9/89	141	89-17555	<0.5	ST	N					Y		0	
35	Beaverton	High School	8/9/89	139	89-14929	<0.5	ST	N					Y		0	
35	Beaverton	High School	8/9/89	129	89-20170	<0.5	ST	N					Y		0	
35	Beaverton	High School	8/9/89	5	89-13185	<0.5*	ST	N				Improperly Sealed	Y		0	
35	Beaverton	High School	8/9/89	147	89-15830	<0.5	ST	N					Y		0	
35	Beaverton	High School	8/9/89	136	89-13125	<0.5	ST	N					Y		0	
35	Beaverton	High School	8/9/89	143	89-12235	<0.5	ST	N					Y		0	
35	Beaverton	High School	8/9/89	131	89-14683	<0.5	ST	N					Y		0	
35	Beaverton	High School	8/9/89	SC	89-21471	<0.5	ST	N					Y		0	
35	Beaverton	High School	8/9/89	123S	89-11206	<0.5	ST	N					Y		0	
35	Beaverton	High School	8/9/89	woodshop	89-15636	<0.5	ST	N					Y		0	
35	Beaverton	High School	8/9/89	127	89-17269	<0.5	ST	N					Y		0	
35	Beaverton	High School	8/9/89	Lib S	89-17246	<0.5	ST	N					Y		0	
35	Beaverton	High School	8/9/89	157 N	89-17637	<0.5	ST	N					Y		0	
35	Beaverton	High School	8/9/89	5	89-19529	<0.5	ST	N					Y		0	
35	Beaverton	High School	8/9/89	185	89-16248	<0.5	ST	N					Y		0	
36	Sunset	High School	8/8/89	E8	89-4935	4.4	ST	Y	11/6/89	89-18715	1.1		Y		4.4	1.1

2016 BSD Radon Sample Spreadsheet Database

Original Site #	Site Name	Facility Type	Test Date	Room Area Location	Sample Number	Result (pCi/l)	Test Type	Area Retested?	Test Date	Retested Sample #	Retested Sample Result (pCi/l)	Comments	Test Location on Floor Plan?	Misc	Result(value) (pCi/l)	Retested Sample Result (value) (pCi/l)
36	Sunset	High School	8/8/89	A8B	89-4941	1.6	ST	N					Y		1.6	
36	Sunset	High School	8/8/89	C7	89-1248	1.4	ST	N					Y		1.4	
36	Sunset	High School	8/8/89	E6	89-16942	1.4	ST	N					Y		1.4	
36	Sunset	High School	8/8/89	GYM	89-20379	1.2	ST	N					Y		1.2	
36	Sunset	High School	8/8/89	G5	89-11705	1.2	ST	N					Y		1.2	
36	Sunset	High School	8/8/89	C9	89-11753	0.9	ST	N					Y		0.9	
36	Sunset	High School	8/8/89	E2	89-4958	0.8	ST	N					Y		0.8	
36	Sunset	High School	8/8/89	F1	89-11733	0.8	ST	N					Y		0.8	
36	Sunset	High School	8/8/89	D12	89-11725	0.6	ST	N					Y		0.6	
36	Sunset	High School	8/8/89	Auditorium	89-22762	0.6	ST	N					Y		0.6	
36	Sunset	High School	8/8/89	K1	89-10099	<0.5	ST	N					Y		0	
36	Sunset	High School	8/8/89	A9	89-21812	<0.5	ST	N					Y		0	
36	Sunset	High School	8/8/89	5-2	89-4953	<0.5	ST	N					Y		0	
36	Sunset	High School	8/8/89	5-3	89-4518	<0.5	ST	N					Y		0	
36	Sunset	High School	8/8/89	D10	89-22639	<0.5	ST	N					Y		0	
36	Sunset	High School	8/8/89	G1	89-21818	<0.5	ST	N					Y		0	
36	Sunset	High School	8/8/89	A7	89-21820	<0.5	ST	N					Y		0	
36	Sunset	High School	8/8/89	B2	89-10098	<0.5	ST	N					Y		0	
36	Sunset	High School	8/8/89	A10	89-16945	<0.5	ST	N					Y		0	
36	Sunset	High School	8/8/89	G6	89-5216	<0.5	ST	N					Y		0	
36	Sunset	High School	8/8/89	B1	89-19543	<0.5	ST	N					Y		0	
36	Sunset	High School	8/8/89	G7	89-16982	<0.5	ST	N					Y		0	
36	Sunset	High School	8/8/89	B4	89-4996	<0.5	ST	N					Y		0	
36	Sunset	High School	8/8/89	C6	89-21414	<0.5	ST	N					Y		0	
36	Sunset	High School	8/8/89	5-1	89-23869	<0.5	ST	N					Y		0	
36	Sunset	High School	8/8/89	E7	89-17186	<0.5	ST	N					Y		0	
36	Sunset	High School	8/8/89	F3	89-4931	<0.5	ST	N					Y		0	
36	Sunset	High School	8/8/89	F6	89-10072	<0.5	ST	N					Y		0	
36	Sunset	High School	8/8/89	H3	89-4578	<0.5	ST	N					Y		0	
36	Sunset	High School	8/8/89	Office	89-4576	<0.5	ST	N					Y		0	
36	Sunset	High School	8/8/89	I9	89-16944	<0.5	ST	N					Y		0	
36	Sunset	High School	8/8/89	E4	89-10092	<0.5	ST	N					Y		0	
36	Sunset	High School	8/8/89	Dining	89-22708	<0.5	ST	N					Y		0	
36	Sunset	High School	8/8/89	E3	89-9431	<0.5	ST	N					Y		0	
36	Sunset	High School	8/8/89	E5	89-22706	<0.5	ST	N					Y		0	
36	Sunset	High School	8/8/89	D7	89-20991	<0.5	ST	N					Y		0	
36	Sunset	High School	8/8/89	H2	89-10075	<0.5	ST	N					Y		0	
36	Sunset	High School	8/8/89	O4	89-22585	<0.5	ST	N					Y		0	
36	Sunset	High School	8/8/89	F7	89-14909	<0.5	ST	N					Y		0	
36	Sunset	High School	8/8/89	G8	89-16981	<0.5	ST	N					Y		0	
36	Sunset	High School	8/8/89	5-1	89-10073	<0.5	ST	N					Y		0	
36	Sunset	High School	8/8/89	G2	89-22740	<0.5	ST	N					Y		0	
36	Sunset	High School	8/8/89	A6	89-20502	<0.5	ST	N					Y		0	
36	Sunset	High School	8/8/89	E1	89-11577	<0.5	ST	N					Y		0	
36	Sunset	High School	8/8/89	A2	89-22737	<0.5	ST	N					Y		0	
36	Sunset	High School	8/8/89	Activity Rm	89-21811	<0.5	ST	N					Y		0	
36	Sunset	High School	8/8/89	G3	89-10093	<0.5	ST	N					Y		0	
36	Sunset	High School	8/8/89	F4	89-10097	<0.5	ST	N					Y		0	
36	Sunset	High School	8/8/89	B3	89-22707	<0.5	ST	N					Y		0	
36	Sunset	High School	8/8/89	F5	89-23060	<0.5	ST	N					Y		0	
36	Sunset	High School	8/8/89	G10	89-21862	<0.5	ST	N					Y		0	
36	Sunset	High School	8/8/89	Auditorium	89-22586	<0.5	ST	N					Y		0	
36	Sunset	High School	8/8/89	G4	89-20612	<0.5	ST	N					Y		0	
36	Sunset	High School	8/8/89	A1	89-20424	<0.5	ST	N					Y		0	
36	Sunset	High School	8/8/89	Activity Rm	89-21448	<0.5	ST	N					Y		0	
36	Sunset	High School	8/8/89	H1	89-16355	<0.5	ST	N					Y		0	
36	Sunset	High School	8/8/89	GYM	89-20394	<0.5	ST	N					Y		0	
36	Sunset	High School	8/8/89	Dining	89-4949	<0.5	ST	N					Y		0	
36	Sunset	High School	8/8/89	G9 B	89-1074	<0.5	ST	N					Y		0	
36	Sunset	High School	8/8/89	D9	89-23898	<0.5	ST	N					Y		0	
36	Sunset	High School	8/8/89	A4	89-11700	<0.5	ST	N					Y		0	
36	Sunset	High School	8/8/89	1-20 B	89-9430	<0.5	ST	N					Y		0	
37	Administration Building	Administration	8/8/89	4	89-5259	5.2	ST	Y	9/8/89	89-2318	<0.5	11/27/89, 89-21776, 1.0	Y		5.2	0
37	Administration Building	Administration	8/8/89	6	89-6659	0.8	ST	N					Y		0.8	
37	Administration Building	Administration	8/8/89	1	89-4950	<0.5	ST	N					Y		0	
37	Administration Building	Administration	8/8/89	7	89-11737	<0.5	ST	N					Y		0	
37	Administration Building	Administration	8/8/89	8	89-4945	<0.5	ST	N					Y		0	
37	Administration Building	Administration	8/8/89	3	89-1331	<0.5	ST	N					Y		0	
37	Administration Building	Administration	8/8/89	2	89-20397	<0.5	ST	N					Y		0	

Attachment 4

BSD Radon Training Powerpoint

Indoor Air Hazards - Radon

Beaverton School District Radon Program

Nathan K. Potter, P.E.

Administrator for Maintenance Services



Radon

- Radioactive gas
- Radon in air is ubiquitous
- Found in outdoor air and indoor air of buildings of all kinds
- No known safe level of radon

Radon is a  colorless, odorless, tasteless, **radioactive** gas.

Radon “Daughters”

Uranium-238 Radioactive Decay Chain

Radon, Polonium, Lead, Bismuth, and Polonium have short half-lives

Results in several exposures in a short time



Radon in Lungs



- Radon or decay products inhaled
- Particles irradiate lungs
- Irradiation can cause damage to lung tissue which can lead to cancer

What Health Issues are Associated With Radon?

- ***According to the EPA:***
 - ***Radon*** is number one cause of lung cancer among non-smokers
 - Second leading cause of lung cancer
 - Responsible for about 21,000 lung cancer deaths every year
 - About 2,900 lung cancer deaths are among people who have **never smoked**

Radon – EPA Action Levels

- Red alert - radon level above 4 pCi/L (pico Curies per Liter)
- Yellow alert - radon levels between 2 pCi/L and 4 pCi/L
- Average radon indoor air about 1.3 pCi/L



Radon hazard potential in Oregon

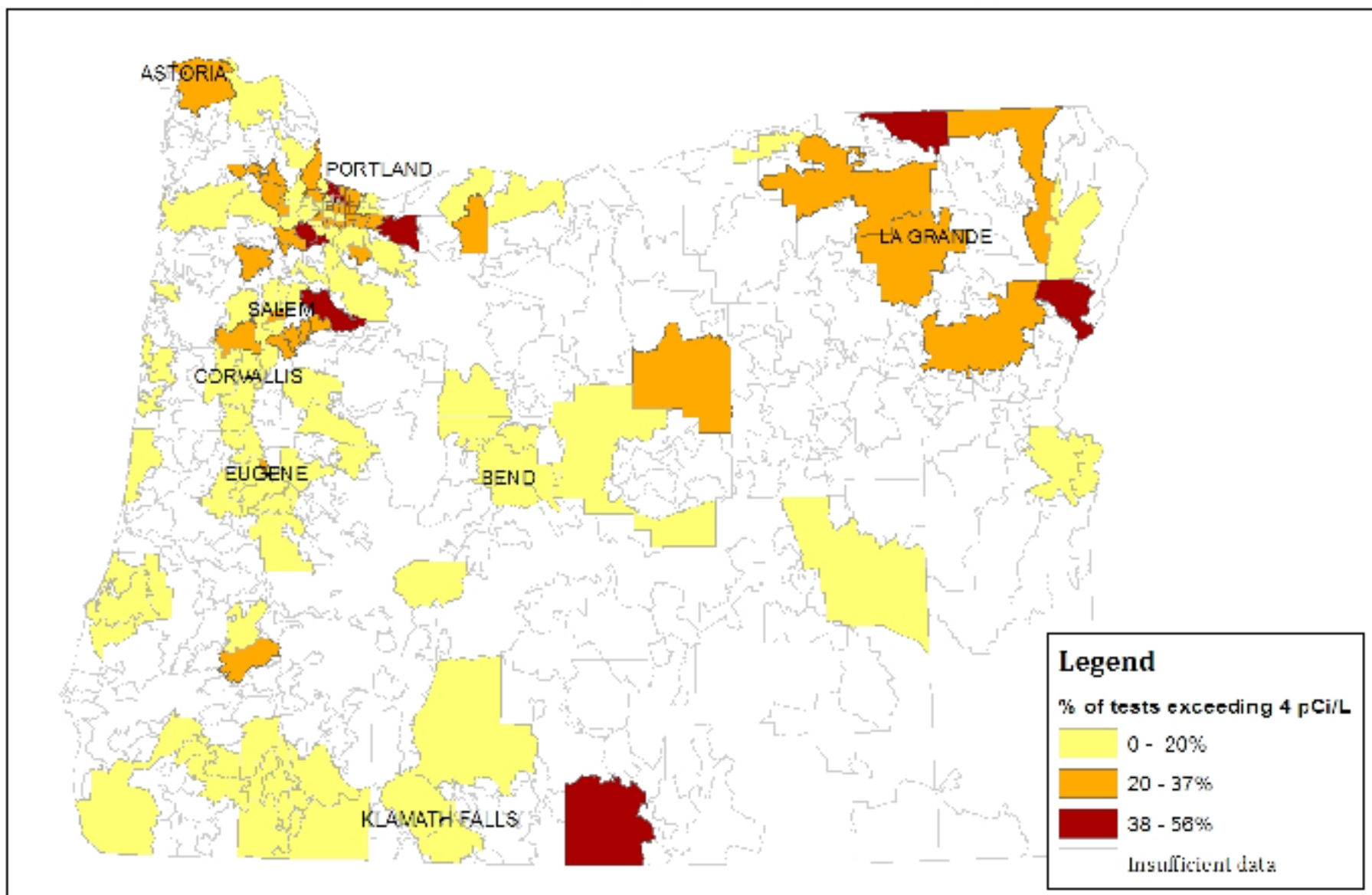

Long-term test data were provided by test kit manufacturers to the Oregon Radon Program and analyzed at Portland State University's Department of Geology. Zip codes are classified by the average test result. For detailed results please see healthoregon.org/radon.

The Environmental Protection Agency recommends mitigation for radon levels exceeding 4 pCi/L.

Radon hazard potential in the Portland Metropolitan area

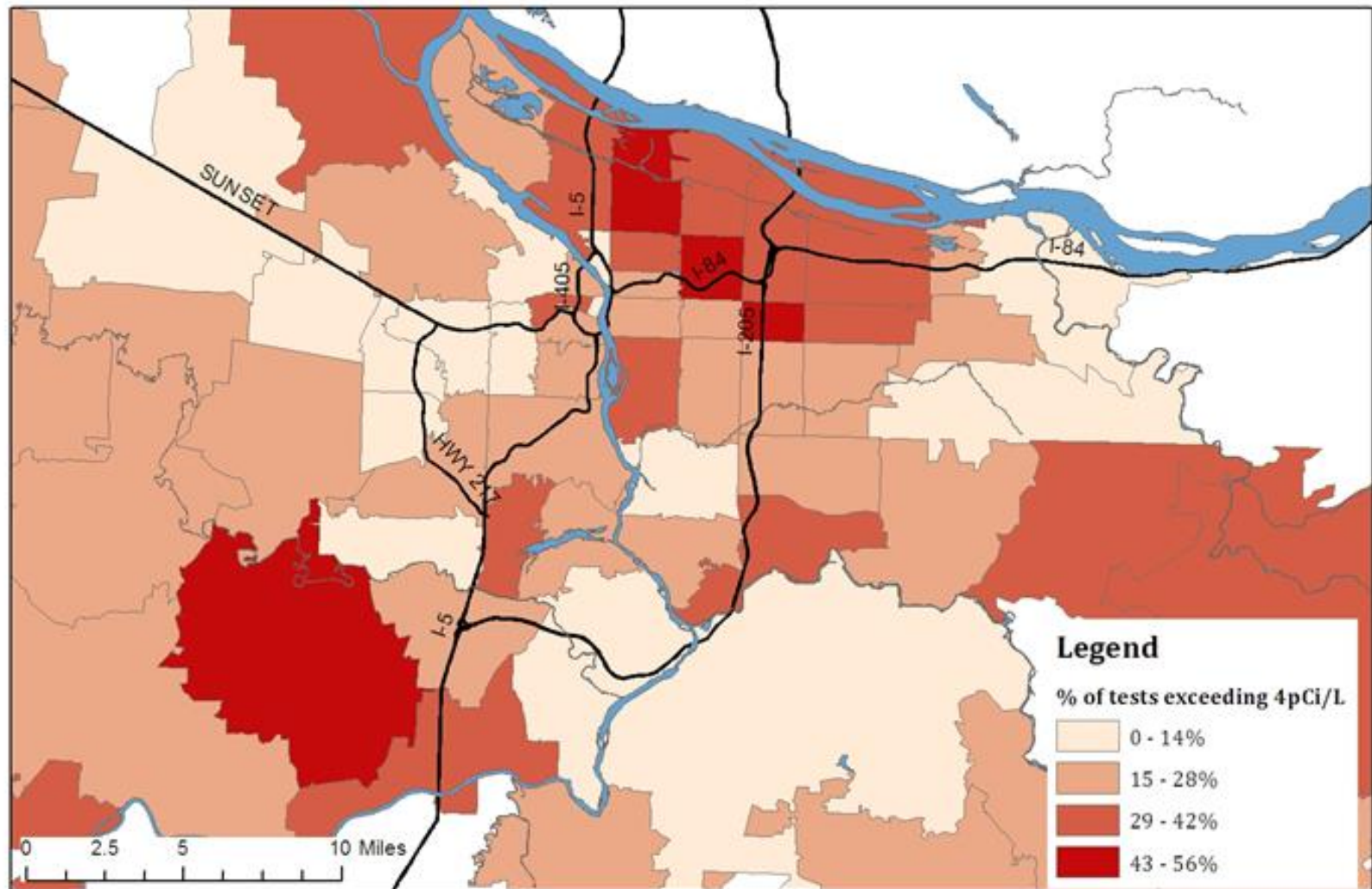

Long-term test data were provided by test kit manufacturers to the Oregon Radon Program and analyzed at Portland State University's Department of Geology. Zip codes are classified by the average test result. The Environmental Protection Agency recommends mitigation for radon levels exceeding 4 pCi/L.



Portland State
UNIVERSITY

Oregon
Health
Authority

Where is Radon found?

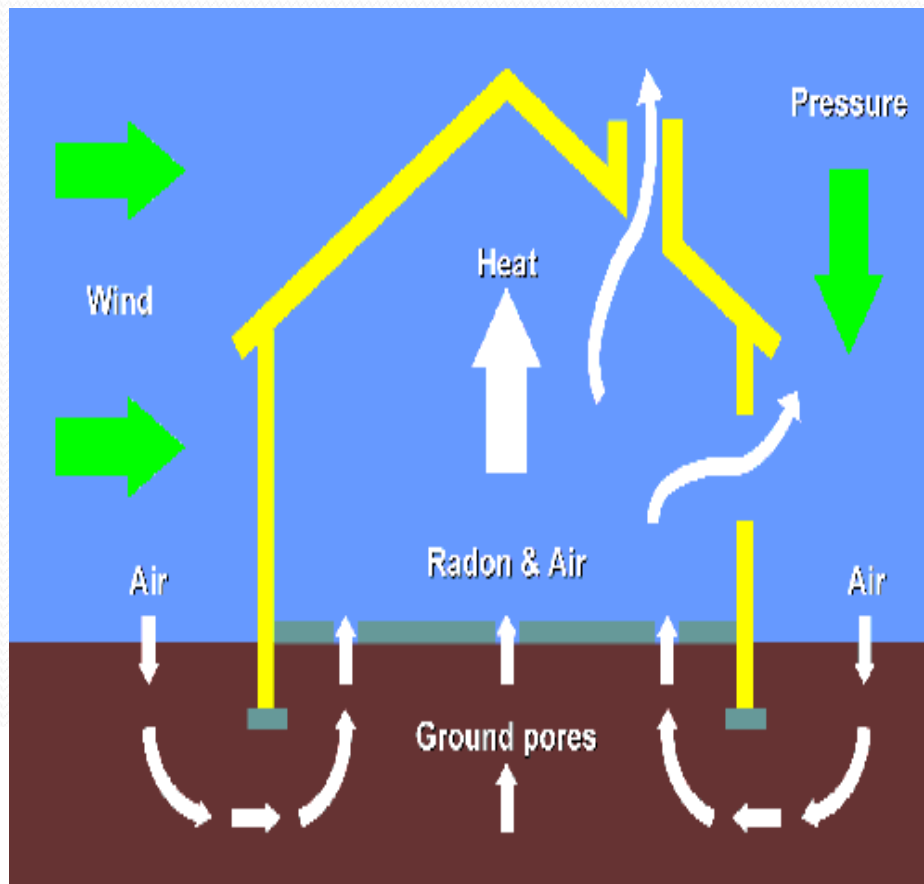

- Comes from soil
- Lower parts of building at greatest risk
- “Stack effect” pulls Radon into home
- Found in all 50 states
- Found in about 1 out of

Radon Testing

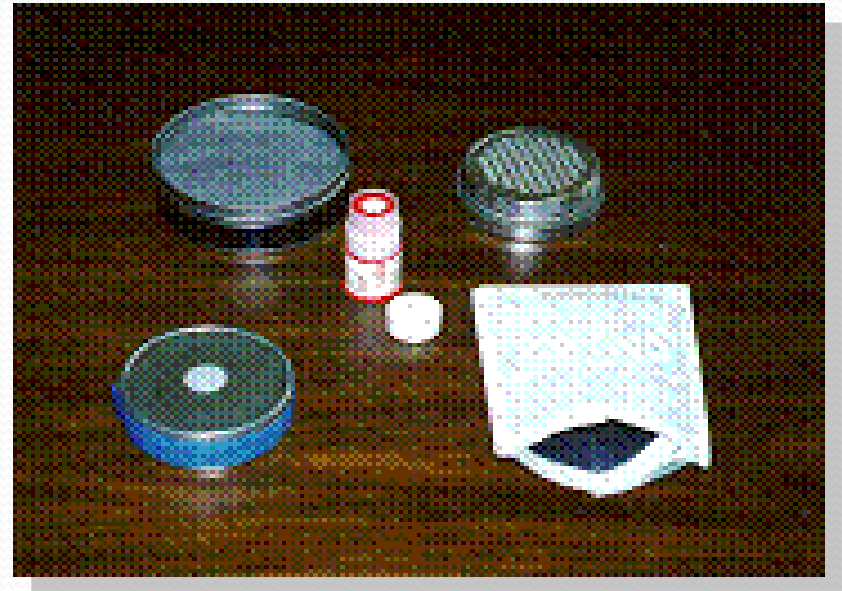

Two types of tests, short term and long term tests.....

Radon Test Kits

- Individuals can purchase test kits
 - online at www.epa.gov/radon/radontest.html
 - at local hardware store



Radon Mitigation

TYPICAL RADON MITIGATION SYSTEM

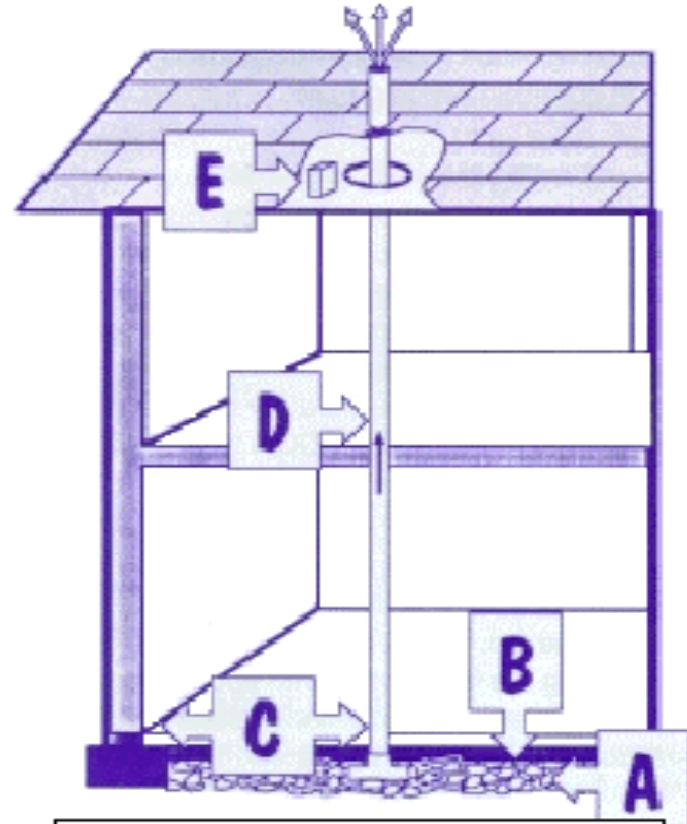
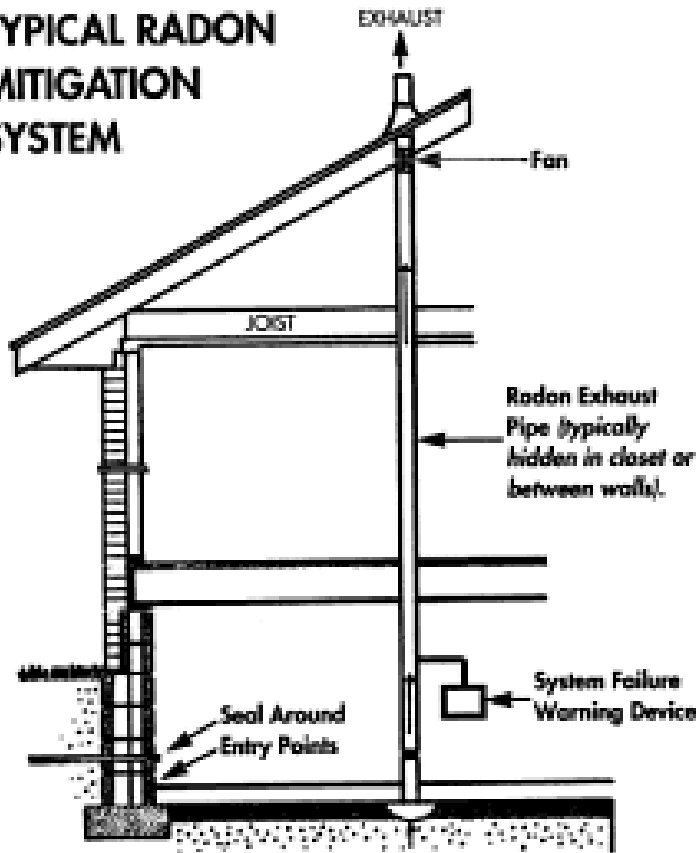

**A gravel; B plastic sheeting;
C sealing; D passive stack;
E space for fan in stack**

Radon Mitigation

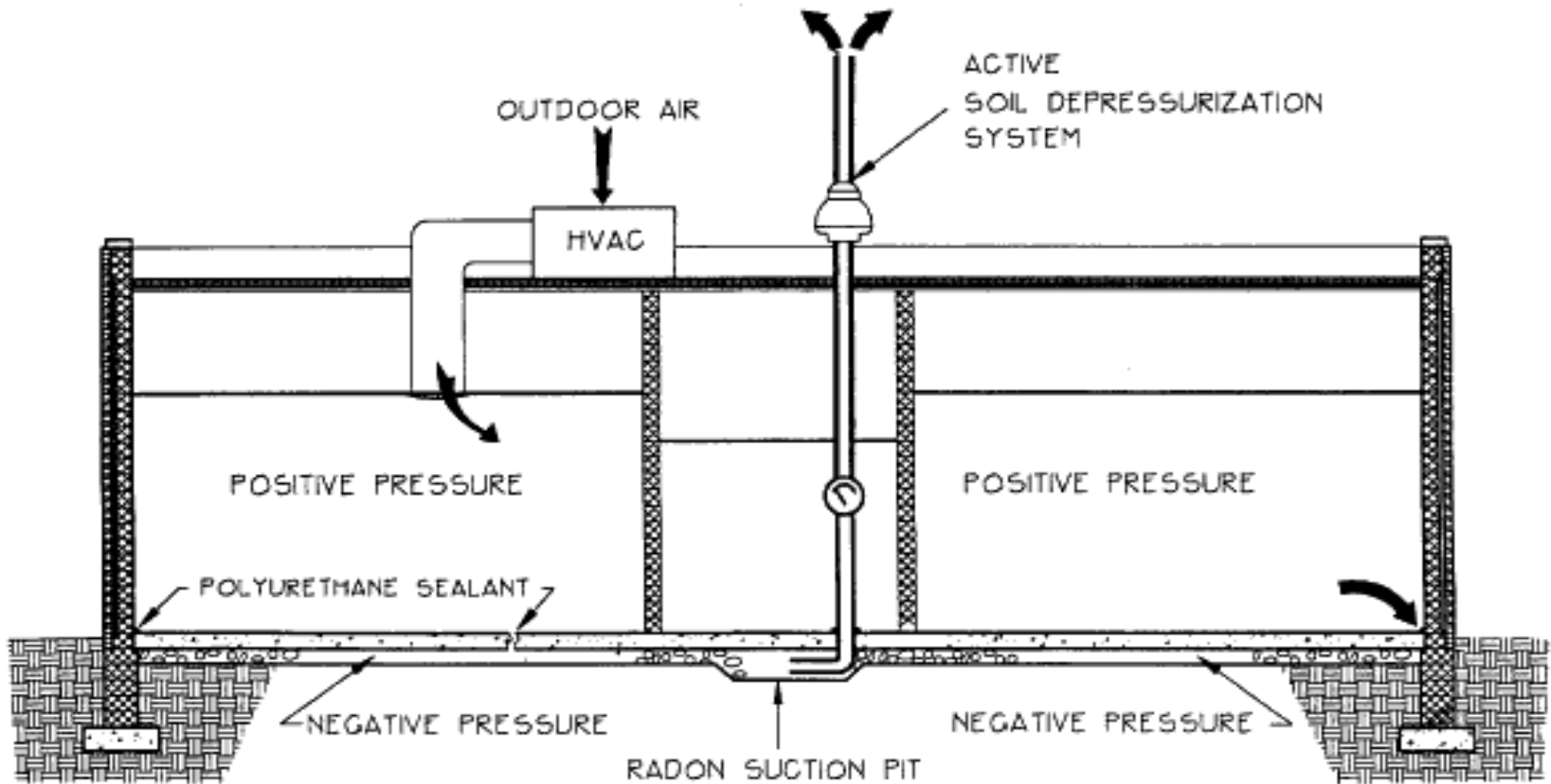

BSD Radon Sample History

- 1989 - Conducted representative sampling in-house
 - 36 samples found above 4 pCi/L
 - Only 3 classrooms retested remained over limit
 - Aloha HS, Errol Hassell ES, and Greenway ES
- 2001 – ATC revisited those 3 schools + 10% school screening
 - 10% included Beaverton HS, Montclair ES, Mountain View MS and Ridgewood ES
 - **All samples tested negative except Errol Hassell which was a corrected ventilation issue**

BSD Radon Program Project

- In 2013, BSD hired AMEC to develop a current program
 - Elements included:
 - Gather and analyze all existing data
 - Develop a dynamic sample database spreadsheet
 - Identify data gaps
 - Develop BSD Radon Program
 - Provide sampling plan options
 - Estimate scenario costs
 - Provide program level training

New BSD Radon Database

- Legacy and all new radon results are captured here:

Original Site #	Site Name	Test Date	Room Area Location	Sample Number	Result (pCi/l)	Test Type	Area Retested?	Test Date	Retested Sample #	Retested Result (pCi/l)	Comments	Test on Floor Plan?
3	Beaver Acres Elementary School	8/9/89	Classroom 11	89-23849	4.8	ST	Y	11/13/89	89-18755	<0.5		Y
4	Bethany Elementary School	8/8/89	Classroom 8	89-13745	5.4	ST	Y	11/6/89	89-18724	0.9		Y
6	Chehalem Elementary School	8/9/89	Classroom 14	89-3779	5.5	ST	Y	9/14/89	89-2179	1.3*	2nd Retest, 11/6/89, 89-23548, 0.8* retested 11/6/89, 312, 89-24836, 7.4pCi/l	Y
9	Errol Hassell Elementary School	8/8/89	Classroom 312	89-10256	6.2	ST	Y	9/14/89	89-9717	4.4		Y
9	Errol Hassell Elementary School	8/8/89	Classroom 210	89-16161	5.1	ST	Y	9/14/89	89-7462	2.5		Y
9	Errol Hassell Elementary School	8/8/89	Classroom 315	89-16146	5.0	ST	Y	9/14/89	89-8471	3.9		Y
10	Fir Grove Elementary School	8/8/89	Classroom 19	89-22716	5.4*	ST	Y	9/14/89	89-7443	2.6	Improperly Sealed	Y
10	Fir Grove Elementary School	8/8/89	Classroom 8	89-16593	4.4	ST	Y	11/6/89	89-18778	1.8		Y
10	Fir Grove Elementary School	8/8/89	Classroom 6	89-3908	4.0	ST	N					Y
10	Fir Grove Elementary School	8/8/89	Classroom 12	89-11595	4.0	ST	N					Y
11	Greenway Elementary School	8/8/89	Classroom 13	89-12074	8.3	ST	Y	11/6/89	89-23771	3.8		Y
11	Greenway Elementary School	8/8/89	Classroom 28	89-4677	4.9	ST	Y	11/6/89	89-18713	6.2		Y
12	Hazeldale Elementary School	8/8/89	Classroom MPR	89-16038	4.1	ST	Y	11/16/89	89-18697	1.5		Y
13	Hiteon Elementary School	8/8/89	Classroom 108	89-6900	7.0	ST	Y	9/14/89	89-4993	1.0		Y
14	Kinnaman Elementary School	8/8/89	Music Rm	89-18699	4.5	ST	Y	11/6/89	89-24868	2.7		Y
15	McKay Elementary School	8/9/89	Classroom MPR	89-18118	4.7	ST	Y	11/27/89	89-25476	1.6	11/29/89, 89-23885, 0.8pCi/l	Y
16	McKinley Elementary School	8/9/89	Classroom 15	89-18136	5.5	ST	Y	9/14/89	89-19168	3.4		Y
18	Montclair Elementary School	8/8/89	Classroom 5	89-8938	5.1	ST	Y	9/14/89	89-4484	2.0		Y
18	Montclair Elementary School	8/8/89	Cafeteria	89-6960	4.4	ST	N					Y
21	Raleigh Park Elementary School	8/9/89	Classroom 5	89-8450	5.1	ST	Y	9/18/89	89-2685	<0.5		Y
22	Ridgewood Elementary School	8/9/89	Unknown	89-3324	4.5	ST	N					Y
24	Terra Linda Elementary School	8/8/89	GYM	89-9746	19.9	ST	Y	9/8/89	89-2669	1.8*	Improperly Sealed, 9/12/89, 89-1629, 1.9*	Y
25	Vose Elementary School	8/8/89	Library	89-12643	4.1	ST	Y	11/6/89	89-18783	1.1	11/6/89, 89-24890, 1.7	Y
25	Vose Elementary School	8/8/89	Classroom 7	89-19154	7.0	ST	N					Y
26	West Tualatin View Elementary School	8/8/89	Classroom 4	89-12663	8.6	ST	Y	9/14/89	89-25730	2.1		Y
26	West Tualatin View Elementary School	8/8/89	Classroom 5	89-14366	5.3	ST	Y	9/14/89	89-22372	2.8		Y
26	West Tualatin View Elementary School	8/8/89	Cafeteria	89-12623	4.7	ST	Y	11/6/89	89-24832	<0.5		Y
26	West Tualatin View Elementary School	8/8/89	Classroom 6	89-23688	4.4	ST	Y	11/6/89	89-19433	<0.5		Y
31	Meadow Park Intermediate School	8/9/89	C10	89-13799	22.4	ST	Y	9/14/89	89-4969	<0.5*	10/13/89, 89-23779, < 0.5	Y
31	Meadow Park Intermediate School	8/9/89	C2	89-12650	5.5	ST	Y	9/12/89	89-8630	<0.5*		Y
31	Meadow Park Intermediate School	8/9/89	C6	89-8436	5.1	ST	Y	9/8/89	89-6593	1.1*		Y
32	Mountain View Intermediate School	8/9/89	D6/D8	89-18756	6.6	ST	Y	9/14/89	89-7471	0.6		Y
33	Whitford Intermediate School	8/9/89	17	89-19482	4.8	ST	Y	11/6/89	89-24825	1.1	89-18723, 0.6	Y
33	Whitford Intermediate School	8/9/89	A9	89-23781	4.2	ST	Y	11/6/89	89-25465	1.8		Y
34	Aloha High School	8/8/89	J-1	89-14928	9.9	ST	Y	9/11/89	89-2645	4.5	11/20/89, 89-23281, 4.8	Y
34	Aloha High School	8/8/89	J-2	8919432	7.9	ST	Y	9/11/89	89-2670	3.0		Y
34	Aloha High School	8/8/89	Cafeteria 2	89-19464	6.6	ST	Y	9/11/89	89-25438	3.5		Y
34	Aloha High School	8/8/89	Cafeteria 2	89-4678	4.3	ST	Y	9/11/89	89-2840	3.2		Y
36	Sunset High School	8/8/89	B9	89-4935	4.4	ST	Y	11/6/89	89-18715	1.1		Y
37	Administration Building	8/8/89	4	89-5269	5.2	ST	Y	9/8/89	89-2318	<0.5	11/27/89, 89-21776, 1.0	Y
39	Maintenance Building	8/8/89	1	89-9763	4.5	ST	Y	11/6/89	89-18722	<0.5		Y

BSD Current Radon Data Gaps

- Data Gaps Identified and Prioritized:
 1. Sample new sites built or acquired since 1989 that have no sample data.
 2. Sample new school additions completed after 1989 that have no radon sample data.
 3. Schools with detectable radon results should be resampled to verify non-detect (ND) status.
 4. Sites with non-detectable radon results should be resampled to verify original ND sample results.

BSD Radon Sampling Plan

- Targeted Approach' Developed
 - Tasks assigned from prioritized data gaps with a specific table that includes:
 - Applicable sites
 - Building description
 - Minimum sample count based on square footage
 - 6 – 20 sample range minimum
 - *Qualified consultant or trained BSD personnel conduct representative samples in strategic 'worse-case-scenario' locations*

TABLE 1A
Radon Sampling for Schools and Facilities
Not Previously Sampled

Site	Square Footage	Building Description	Recommended Samples
ACMA	45,000 SF	Slab on grade	10-15 samples
Admin Aloha Branch	5,000 SF	Slab on grade	6-10 samples
Aloha-Huber	107,000 SF	Two stories – slab on grade	10-15 samples
Bonny Slope	80,000 SF	two stories – slab on grade	8-12 samples
Conestoga	129,000 SF	Slab on grade	10-15 samples
Findley	72,000 SF	Slab on grade	6-10 samples
H&SS/ Capital Center	189,000 SF	Slab on grade	15-20 samples
Jacob Wismer	73,000 SF	Slab on grade	6-10 samples
Merle Davies	39,000 SF	Crawl space and slab on grade combination-	6-10 samples
Merio Station	51,000 SF	Slab on grade	6-10 samples
Nancy Ryles	71,000 SF	Slab on grade	6-10 samples
Scholls Heights	70,000 SF	Slab on grade	6-10 samples
Sexton Mountain	7,000 SF	Crawl space and slab on grade combination-	6-10 samples
Southridge	256,000 SF	Slab on grade	15-20 samples
Springville	87,000 SF	Slab on grade	8-12 samples
Stoller	144,000 SF	Slab on grade	10-15 samples
Westview	281,000 SF	Slab on grade	15-20 samples
Transportation Allen	10,000 SF	Slab on grade	6-10 samples
Transportation & Support Center	54,000 SF	Slab on grade	8-12 samples
Transportation 5 th St. N.	5,200 SF	Slab on grade	6-10 samples

BSD Radon Program

Sampling Task Overview

FIVE (5) TASKS TO BE COMPLETED BETWEEN AUGUST 2015 – APRIL 2016

- **TASK 1 – Consultant Sampling** - sample all new sites and additions since 1989 that have no prior sample data
 - All elements handled by qualified consultant
 - October 2015 – January 2016
- **TASK 2 – BSD Sampling** - sample schools and facilities with *prior detectable radon results*
 - Representative sampling conducted by trained BSD personnel - project managed by the consultant
 - February 2016 – April 2016

BSD Radon Program

Sampling Task Overview

- **TASK 3 – BSD Sampling** - Sample all remaining schools and facilities with *prior non-detectable radon results*
 - Sampling conducted by BSD personnel and managed by the consultant –same as Task 2
 - February – April 2016
- **TASK 4 – BSD Sampling** - Re-sample all areas with radon *results above 4.0 pCi/L EPA guideline*
 - Sampling responsibilities same as Task 2 & 3
 - March – April 2016

BSD Radon Program

BSD Involvement

TASKS 2-4 – BSD Sampling Summary

- Consultant will assist BSD in managing the sampling effort
 - This includes developing a site-specific room-by-room sampling plan for BSD staff to follow.
 - Consultant will also provide pre- and post- sampling communication and notification to all school and facility occupants.
- Trained BSD personnel will conduct the following:
 - Place BSD supplied radon sample kits in identified rooms throughout the school or facility.
 - Record sample start date and time at beginning of sample.
 - Collect samples after an approximate 3 day period, seal the containers, and record the ending date and time.
 - Package samples for consultant pick-up.

BSD Radon Program Training

TASK 5 – Radon Training

- Actually the 1st task conducted in August 2015
- The consultant will develop BSD-specific radon training program to deliver to select BSD personnel at the foreman training in August 2015.
- Training will provide comprehensive sample instruction/procedures to BSD personnel on how to collect radon sample kits at their school or facility.
- Consultant will assist in managing this sampling effort and provide site-specific room-by-room sampling plan.

BSD Radon Program Future?

WHAT HAPPENS AFTER TASKS 1-5?

- After re-sampling all sample areas with elevated radon levels the consultant will confirm these results and provide recommendations to mitigate.
- Mitigation will include some level of engineering control from sealing cracks to promoting air flow to installing a radon mitigation system.
- After all initial sample results have been addressed the BSD radon program will be reviewed to determine whether additional phases of sampling will be necessary.

More Radon Information

- EPA - <http://www.epa.gov/radon/>
- National Environmental Health Association - www.neha-nrpp.org/
- National Radon Safety Board - www.nrsb.org

Questions? Comments? Concerns?

Nathan K. Potter, P.E.
Administrator for Maintenance Services

503-591-4550
nathan.potter@Beaverton.k12.or.us

APPENDICIES

Appendix A

Oregon Legislative Rule HB 2931 and ORS 332.166-167

Enrolled
House Bill 2931

Sponsored by Representative KENY-GUYER, Senator DEMBROW; Representative BUEHLER

CHAPTER

AN ACT

Relating to testing radon levels; and declaring an emergency.

Be It Enacted by the People of the State of Oregon:

SECTION 1. (1) The Oregon Health Authority shall disseminate information related to elevated levels of radon to each school district in this state. Information disseminated under this section must include:

- (a) Information about radon and the dangers associated with elevated levels of radon;
 - (b) The level of radon at which the United States Environmental Protection Agency recommends schools take action to reduce indoor radon concentrations;
 - (c) Processes by which schools may be tested for elevated levels of radon; and
 - (d) Model plans developed pursuant to section 2 of this 2015 Act.
- (2) Dissemination of information under subsection (1)(c) of this section must take into account industry standards for testing buildings for elevated levels of radon.

(3) Upon request, the State Board of Education shall assist the authority in disseminating the information described in this section. Dissemination of information may occur by any reasonable means, including posting the information on a website maintained by the authority or the Department of Education and providing each school district with instructions on how to access the information.

SECTION 2. (1) A school district shall develop a plan for testing schools for elevated levels of radon. At a minimum, plans developed under this subsection must:

- (a) Provide for the testing of radon in any frequently occupied room in contact with the ground or located above a basement or a crawlspace; and
 - (b) Provide for the testing of radon in a school at least once every 10 years.
- (2) The Oregon Health Authority shall develop model plans for school districts to follow in implementing the requirements of this section. The authority shall seek the input of the Oregon School Boards Association in developing the model plans.
- (3) Results of a test performed under this section must be:
- (a) Provided to the district school board;
 - (b) Provided to the authority in a manner prescribed by the authority; and
 - (c) Made readily available to parents, guardians, students, school employees, school volunteers, administrators and community representatives at the school's office or school district's office or on a website for the school or school district.
- (4) Information provided and made available under subsection (3) of this section must include the level of radon at which the United States Environmental Protection Agency recommends schools take action to reduce indoor radon concentrations.

SECTION 3. (1) A school district shall submit the plan developed under section 2 of this 2015 Act to the Oregon Health Authority on or before September 1, 2016.

(2) Notwithstanding section 2 (1)(b) of this 2015 Act, plans developed under section 2 of this 2015 Act shall require initial testing of schools for elevated levels of radon on or before January 1, 2021.

(3) Subsection (2) of this section does not apply to any school that has been tested for elevated levels of radon on or after January 1, 2006.

SECTION 4. This 2015 Act being necessary for the immediate preservation of the public peace, health and safety, an emergency is declared to exist, and this 2015 Act takes effect on its passage.

Passed by House July 1, 2015

.....
Timothy G. Sekerak, Chief Clerk of House

.....
Tina Kotek, Speaker of House

Passed by Senate July 6, 2015

.....
Peter Courtney, President of Senate

Received by Governor:

.....M.,....., 2015

Approved:

.....M.,....., 2015

.....
Kate Brown, Governor

Filed in Office of Secretary of State:

.....M.,....., 2015

.....
Jeanne P. Atkins, Secretary of State

Oregon Revised Statute (ORS) 332.166-167

332.166 Provision of information to school districts about elevated levels of radon. (1) The Oregon Health Authority shall disseminate information related to elevated levels of radon to each school district in this state. Information disseminated under this section must include:

- (a) Information about radon and the dangers associated with elevated levels of radon;
- (b) The level of radon at which the United States Environmental Protection Agency recommends schools take action to reduce indoor radon concentrations;
- (c) Processes by which schools may be tested for elevated levels of radon; and
- (d) Model plans developed pursuant to ORS 332.167.

(2) Dissemination of information under subsection (1)(c) of this section must take into account industry standards for testing buildings for elevated levels of radon.

(3) Upon request, the State Board of Education shall assist the authority in disseminating the information described in this section. Dissemination of information may occur by any reasonable means, including posting the information on a website maintained by the authority or the Department of Education and providing each school district with instructions on how to access the information. [2015 c.729 §1]

Note: 332.166 and 332.167 were enacted into law by the Legislative Assembly but were not added to or made a part of ORS chapter 332 or any series therein by legislative action. See Preface to Oregon Revised Statutes for further explanation.

332.167 Tests of schools for elevated levels of radon; plan; results. (1) A school district shall develop a plan for testing schools for elevated levels of radon. At a minimum, plans developed under this subsection must:

- (a) Provide for the testing of radon in any frequently occupied room in contact with the ground or located above a basement or a crawlspace; and
- (b) Provide for the testing of radon in a school at least once every 10 years.

(2) The Oregon Health Authority shall develop model plans for school districts to follow in implementing the requirements of this section. The authority shall seek the input of the Oregon School Boards Association in developing the model plans.

(3) Results of a test performed under this section must be:

- (a) Provided to the district school board;
- (b) Provided to the authority in a manner prescribed by the authority; and
- (c) Made readily available to parents, guardians, students, school employees, school volunteers, administrators and community representatives at the school's office or school district's office or on a website for the school or school district.

(4) Information provided and made available under subsection (3) of this section must include the level of radon at which the United States Environmental Protection Agency recommends schools take action to reduce indoor radon concentrations. [2015 c.729 §2]

Note: Section 3, chapter 729, Oregon Laws 2015, provides:

Sec. 3. (1) A school district shall submit the plan developed under section 2 of this 2015 Act [332.167] to the Oregon Health Authority on or before September 1, 2016.

(2) Notwithstanding section 2 (1)(b) of this 2015 Act, plans developed under section 2 of this 2015 Act shall require initial testing of schools for elevated levels of radon on or before January 1, 2021.

(3) Subsection (2) of this section does not apply to any school that has been tested for elevated levels of radon on or after January 1, 2006. [2015 c.729 §3]

Note: See note under 332.166.

Appendix B

Oregon Health Authority '*Protocol for Elevated Radon in Schools*'

Testing for Elevated Radon in Oregon Schools



Version 1.0 - 2016

A Protocol and Plan

This document provides Oregon school districts with a protocol to accurately test for elevated radon levels in school buildings, per Oregon Revised Statute (ORS) 332.166-167.

Plans may be submitted by e-mail, fax, or mail to:

Oregon Radon Awareness Program

800 NE Oregon St, Suite 640

Portland, OR 97232-2162

radon.program@state.or.us

Fax: 971-673-0979

Table of contents

» Table of contents	iii
» Notice	iv
» Acknowledgment	v
» Introduction	6
» Protocol objectives	7
» What is radon?	8
» Why is radon a problem?	9
» How is radon reported?.....	11
» What radon studies have been completed in schools?.....	12
» What is the U.S. EPA action level?	12
» Where do we spend our time?	12
» What are the routes of radon entry?.....	13
» Environmental factors influencing radon concentrations	16
» Types of radon measurement devices	18
» Quality assurance	29
» Radon testing process guide	33
» Interpreting initial results	37
» After receiving results of follow-up testing	39
» References.....	41
» Websites	42
» Glossary.....	43
» Appendix A: Radon test placement protocol checklist.....	45
» Appendix B: Signage for school radon measurement	48
» Appendix C: Memo to parents and staff about radon measurement	49
» Appendix D: Step-by-step guide for planning radon testing in Oregon schools	50
» Appendix E: Frequently asked questions about radon and schools.....	58

Notice

The Oregon Health Authority prepared this protocol, which was funded by a grant from the United States Environmental Protection Agency (EPA) Region 10 Radon Program. Neither the Oregon Health Authority, United States Environmental Protection Agency, any affiliated organization nor any of their employees makes any express or implied warranty or assumes any legal liability or responsibility for the accuracy, completeness or usefulness of any information, apparatus, product or process disclosed. None of these entities or individuals represent that the protocol's use would not infringe on privately owned rights. Reference herein to any specific commercial product, process or service by trade name, trademark manufacturer, or otherwise does not necessarily constitute or imply its endorsement, recommendation or favoring by the Oregon Health Authority, United States Environmental Protection Agency or any affiliated organization.

Acknowledgment

The Oregon Health Authority produced this protocol under direction of (ORS) 332.166-167 in partnership with the Oregon Department of Education. The protocol uses material that the American Lung Association of the Upper Midwest created under contract. The protocol was adapted with permission from the Iowa Department of Public Health. The content of this protocol was reviewed by the Oregon School Boards Association and the Oregon Radon Coalition.

Please send any comments about this document to the Oregon Health Authority Public Health Division, 800 N.E. Oregon Street, Suite 640, Portland, OR 97232. Phone: 971-673-0440.

Email radon.program@state.or.us.

www.healthoregon.org/radon.

Introduction

Radon is the number-one cause of lung cancer among non-smokers, according to EPA estimates. Although no amount of radon is safe, people can take steps to reduce its potential for harm.

Measuring and reducing elevated radon at home is the most effective way to decrease radon's harm. School buildings are the second leading source of radon exposure for students and school employees.

Elevated radon is found throughout Oregon and in a variety of structures. The only way to know if a building has elevated radon is to test.

The 2015 Oregon Legislature passed House Bill (HB) 2931 to assess elevated radon levels in Oregon schools. HB 2931 later became Oregon Revised Statute (ORS) 332.166-167. The Oregon Health Authority (OHA), directed by ORS 332.166-167, produced this guide to help Oregon school districts accurately measure their school buildings for elevated radon. Per the statute, this guide follows current national guidelines for measuring radon in schools and large buildings (1). It is based on radon school measurement plans from other states.

Under the statute, school districts are to submit a plan to Oregon Health Authority by Sept. 1, 2016. OHA recommends, but does not require, that school districts create a specific plan for testing each school site before testing begins.

Per ORS 332.166-167, actual testing of schools must be done on or before Jan. 1, 2021. The testing results must be sent to OHA and posted on the school or school district's website. These requirements do not apply to schools that have been tested for elevated radon on or after Jan. 1, 2006.

This protocol's appendices contain "Frequently Asked Questions about Radon and Schools" and other tools and step-by-step instructions to help schools plan and carry out radon testing.

Thank you for the part you play in raising radon awareness.

Oregon Health Authority
Public Health Division
Radon Awareness Program

Protocol objectives

This protocol addresses learning objectives for radon screening measurements in schools. The objectives are for schools to:

1. Accurately carry out testing schools for elevated levels of radon, per ORS 332.166-167.
2. Define the elements and components of radon and radon measurement. Schools are to use appropriate labels, terms and wording, as well as effectively communicate such definitions to others.
3. Understand the relevant laws and elements of physical science to the radon measurement process and the role of physical science in both the introduction and presence of radon in the environment.
4. Forecast how when, where and why radon occurs, and predict how radon will behave at different times, in different places and/or under different circumstances.
5. Measure relevant properties of radon; use appropriate scales of measurement; interpret both status and change; and interpret measurements' validity and reliability.
6. Use the standard devices and/or instrumentation approved for radon measurement, understand device calibration and servicing; and understand potential errors related to the devices' misuse or misplacement.
7. Model the required elements of quality control and quality assurance throughout the measurement process as a continuous part of the measurement protocol. Understand the inherent values of a quality controlled approach to measurement.
8. Comply with existing laws, regulations and other established procedural requirements associated with radon measurement. Emulate the importance of legal oversight of radon-related activities.
9. Understand the processes associated with basic radon mitigation.

What is radon?

Radon comes from natural deposits of uranium in the soil. It is found everywhere in the world. Uranium naturally decays into radium that further breaks down into radon gas. While some geographic areas have more radon than others, the only way to determine a building's radon level is to test it. Any building has the potential for elevated levels of radon. Because radon is a gas, it can move up through the soil, allowing it to enter buildings in contact with the soil. Radon is typically at its highest concentration in the lower portion of a building. Once radon enters a building, it is easily dispersed through the air. It then begins a radioactive decay process that leads to creating radon decay products. Radon gas itself is relatively harmless until it produces these decay products. The decay products release damaging energy particles that strike lung tissue and lead to lung tissue damage if inhaled.

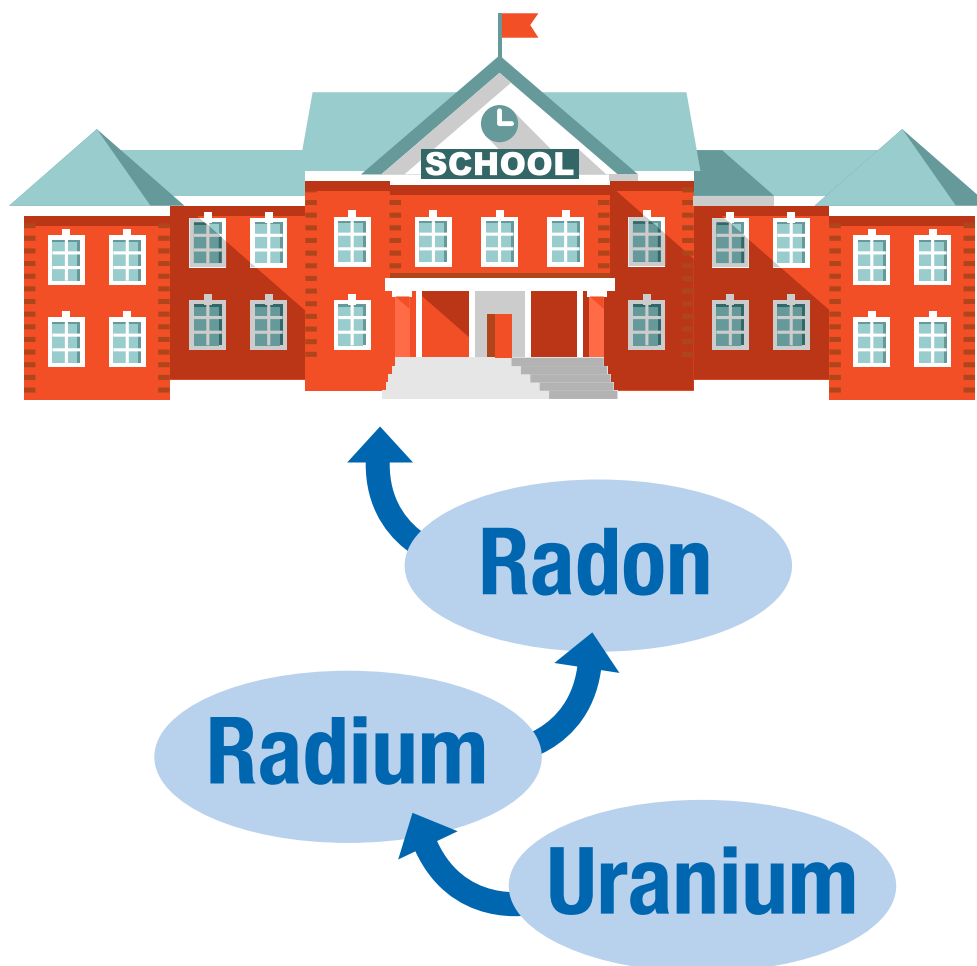

Why is radon a problem?

Radon is a naturally occurring colorless, odorless, tasteless and radioactive gas. Radon travels through the soil and enters buildings through cracks and openings in the foundation. This can occur in buildings or homes of any age and structural type (e.g., with or without basements). Eventually, radon decays into radioactive particles (decay products) that can be trapped in the lungs when you breathe. As these particles decay further, they release small bursts of radiation. This radiation can damage lung tissue and lead to lung cancer over the course of a lifetime.

Radon is a human carcinogen. Prolonged exposure to elevated radon concentrations causes an increased risk of lung cancer. Like other environmental pollutants, the extent of radon's health risk is uncertain. However, scientists are more certain about risks from radon than from other cancer-causing environmental pollutants, such as the herbicide glyphosate or the flame retardant chemicals polybrominated biphenyls (PBBs). This is because estimates of radon risk are based on studies of cancer in humans (underground miners and other more current epidemiological studies).

The Surgeon General has warned Americans about the health risk from exposure to radon in indoor air (2) and urged Americans to perform radon testing. Radon is the leading cause of lung cancer for non-smokers in the United States. Breathing radon over prolonged periods can present a significant health risk (3). Other health agencies, including the U.S. Centers for Disease Control and Prevention and the World Health Organization, have made similar conclusions about radon's danger to human health.

Radon and lung cancer

The U.S. Environmental Protection Agency (EPA) ranks radon in the highest classification of cancer-causing substances – Group A. This category only includes those substances with sufficient evidence of causing cancer in humans.

EPA's classification of cancer-causing agents:

- Group A: Known human carcinogen (e.g., radon)
- Group B: Probable carcinogenic (e.g., glyphosate; polybrominated biphenyls)
- Group C: Possibly carcinogenic
- Group D: Not classifiable (no data) and
- Group E: Evidence of non-carcinogenicity

How does radon cause cancer?

Unlike radon, which is a gas, radon decay products are solid particles. These particles become suspended in the air when they are formed. Some of these particles “plate out” (attach to surfaces) and attach themselves to aerosols, dust and smoke particles in the air. Inhaling these particles can deliver a radiation dose to the lungs that can damage lung tissue and affect DNA.

DNA is the fundamental blueprint for all of the body’s structures: The DNA blueprint is encoded in each single human cell. Each cell is continually reading various parts of its own DNA as it constructs fresh molecules to perform a variety of tasks.

The small decay particles, called progeny, exert energy (called ionizing radiation) on the lung tissue and cause damage. They can even strike and disrupt the cell DNA, which damages the cancer suppressant gene and increases the risk for contracting cancer. These collisions and ionization take place very quickly, but the biological effects (i.e., beginnings of cancer) take much longer to emerge. Cancer is produced when the altered DNA code leaves an error in the DNA blueprint. The risk of lung cancer is based on how much you are exposed to and for how long. Scientific research indicates that at least a 10- to 20-year incubation period is required before lung cancer develops.

The EPA estimates that 21,000 radon-related lung cancer deaths occur each year in the United States. Below is a table of estimated U.S. deaths from different cancer types in 2015. If radon-induced lung cancer were its own category (see table on [page 11](#)), it would be our country’s eighth leading cause of death from cancer.

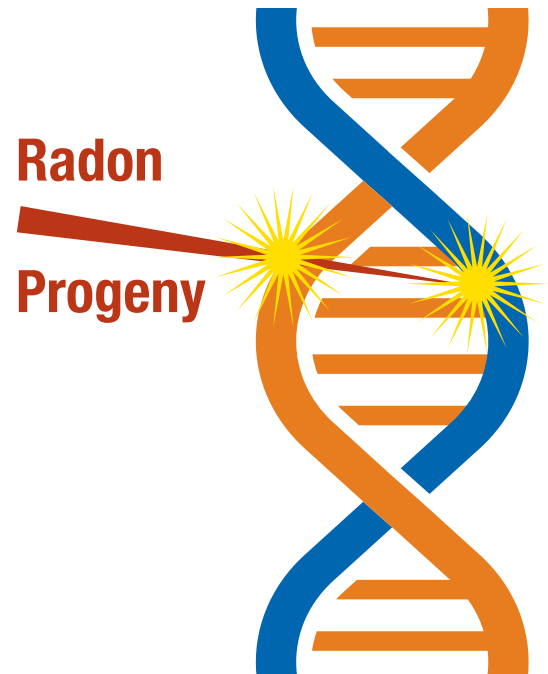

Radon in air continues to decay. These decay products are known as radon progeny and disrupt cell DNA.

Cancer types and estimated U.S. deaths, 2015 (4,5)

Cancer type	Estimated U.S. deaths in 2015
1. Lung and bronchus	158,040
2. Colon and rectum	49,700
3. Breast cancer	40,730
4. Pancreas	40,560
5. Prostate	27,540
6. Liver and bile duct	24,550
7. Leukemia	24,450
Radon-induced lung cancer	21,000
8. Lymphoma	20,940
9. Urinary bladder	16,000
10. Esophagus	15,500
11. Ovary	14,180

Another report of annual deaths from radon-induced lung cancer comes from the National Research Council. It estimates that one in 10 or one in seven (depending on the risk model) of all lung-cancer deaths — ranging from 15,400 or 21,800 per year in the United States — can be attributed to radon exposure. This range is made up of adding deaths from radon exposure among people who have smoked at least 100 cigarettes in their lives (ever-smokers) together with deaths attributable to radon among never-smokers. (6)

Not everyone who breathes in radon (or radon decay products) will develop lung cancer. An individual's risk of lung cancer depends mostly on the concentration of radon, the duration of exposure (over a lifetime) and genetic and health disposition. Smoking combined with radon is an especially serious health risk. The risk of dying from lung cancer caused by radon is much greater for smokers than non-smokers.

Breathing radon does not cause any short-term human health symptoms such as shortness of breath, coughing, headaches or fever. Children (who have higher respiration rates than adults) have been reported to have greater risk than adults for certain types of cancer from radiation. However, no conclusive data exists at this time on whether children are at greater risk than adults from radon. There is no conclusive data at this time that radon exposure causes illnesses other than lung cancer.

How is radon reported?

In the United States, radioactive materials are measured in curies. A curie is the amount of radioactivity released from one gram of radium. A picocurie is

a millionth of a millionth, or a trillionth, of a curie. Radon is measured and reported in picocuries per liters of air (pCi/L).

What radon studies have been completed in schools?

The EPA began investigating radon in schools in 1988. The initial studies show that there were elevated levels of radon in schools in every state.

A further study called the National School Radon Survey showed that 19.3% of all U.S. schools (nearly one in five) have at least one frequently occupied room with short-term radon levels above the **U.S. EPA action level: (≥ 4.0 pCi/L)**. In total, EPA estimates that radon has affected more than 70,000 schoolrooms. (7)

What is the U.S. EPA action level?

U.S. EPA recommends reducing the concentration of radon in indoor environments to below the radon action level of 4.0 pCi/L. This action is not health-based; there is no safe level of radon exposure. While the radon in most buildings can be lowered below 4.0 pCi/L, this may depend on the building's and its grounds' characteristics.

Yet because outdoor levels of radon across the country average 0.4 pCi/L, it's not possible to reduce people's risk from radon exposure to zero. Although no amount of radon is good for a person, radon reduction's goal is to reduce the level and, thus, reduce potential harm.

Where do we spend our time?

A study for the U.S. EPA shows that we spend 87.9% of our time indoors on a daily basis (8). Because many people, particularly children, spend much of their time at home, the home is likely the most significant source of radon exposure. The U.S. EPA estimates that one in 15 U.S. homes have elevated radon 4pCi/L. (9) Some areas of Oregon are found to have higher radon levels than others. But it is very possible that a home in an area considered to have low risk could have elevated radon levels. The opposite could also be true.

The only way to know whether a home has elevated radon levels is to test it.

The second largest contributor to radon exposure for most school children and staff is likely to be their school. As a result, both the EPA and the Oregon Health Authority (OHA) recommend that school buildings as well as homes be tested for radon. This recommendation became law for Oregon schools in the 2015 Legislature (ORS 332.166-167).

What are the routes of radon entry?

Many factors contribute to the entry of radon gas into a school building. Schools that are in the same community can have significantly different radon levels from one another. As a result, school officials cannot know if elevated levels of radon are present without testing.

Radon levels in buildings

The level of radon in a building depends on:

- The concentration of uranium and radium in the soil or underlying geology;
- How easily the radon can be transported into the building through the soil permeability, pathways and openings into the building;
- Air differentials, e.g., the stack effect where warm indoor air leaving the upper parts of a structure is naturally replaced by colder air that may contain radon gas (if at high concentrations in soil);
- How air is transported within a building;
- The ventilation rate of the building.

Entry through pressure-driven transport

The most common way for radon to enter a building is from the soil gas through pressure-driven transport. Pressure-driven transport occurs when a lower indoor air pressure draws air from the soil or bedrock into the building.

Radon transport through soil to building requires:

- A driving force – a force that draws or pushes the radon toward the building;
- A pathway to the home or building – high soil permeability, utility trenches, etc.;
- Openings in the foundation – joints, cracks, earthen areas, utility penetrations, etc.

Schools and large buildings usually operate with an inside air pressure that is lower than the surrounding soil. This allows air, including radon (if present) outside or underneath the building, to be sucked inside. The design and operation of mechanical ventilation systems may also depressurize the building and enhance radon entry.



The air pressure in your home is lower than pressure in the soil under your home's foundation. This difference in pressure makes your house act like a vacuum that sucks radon in through foundation cracks and other openings.

- Buildings can create vacuums that will draw in soil gas.
- These vacuums are very small and are referred to as air pressure differentials.

Entry through diffusion

Radon also can enter buildings when there are no pressure differences. This type of radon movement is called diffusion-driven transport. Diffusion is the same mechanism that causes a drop of food coloring placed in a glass of water to spread through the entire glass. Diffusion-driven transport is rarely the cause of elevated radon levels in existing buildings. It is also highly unlikely that diffusion contributes significantly to elevated radon levels in schools and other large buildings. Many schools and large buildings are built on adjoining slab-on-grade construction, which allows radon gas to enter through the foundation and expansion joints between the slabs as well as cracks in the slabs themselves.

Entry through other mechanisms

Other features, such as the presence of a basement area, crawl spaces, utility tunnels, sub slab heating, ventilation and air conditioning (HVAC) ducts, sumps, drains, cracks, or other penetrations in the slab (e.g., around pipes) also provide areas for radon to enter indoor spaces.

Man-made pathways

- The construction process can disturb native fills and make them more permeable.
- Utility lines and water collection systems often lay in trenches with loose fill or gravel.

Slab penetrations

- Plumbing block-outs for tubs, commodes, showers etc.
- Most are hidden during construction.
- Radon follows loose fill in plumbing trench and is drawn through slab openings.

Plumbing block-outs

- Radon follows plumbing through block-out.

Entry through well water

Another way radon can enter a building is through well (or spring) water. In certain areas of the country, well water supplied directly to a building and in contact with radium-bearing formations can be a source of radon in a building due to the off-gassing of radon when the water is brought inside. Extremely high levels of radon in well water will raise radon gas levels in buildings. For example, 10,000 pCi/L of radon in well water is expected to increase, by itself, the radon in a structure by 1.0 pCi/L. The majority of elevated radon in most buildings will come from the soil underneath, not the well water. To date, the only known health risk associated with exposure to radon in water is a result of the airborne radon released from the water when it is used. For more information on well water quality, contact the Oregon Domestic Well Safety Program at www.healthoregon.org/wells.

Entry through building materials

Radon can also come from building materials. However, this is rarely the cause of elevated levels in existing schools and other large buildings. Building materials — such as concrete, brick stones for fireplaces, granite and sheet rock — may contain some radium and can be sources of indoor radon. The extent of the use of radium-contaminated building materials is unknown, but it is generally believed to be very minor.

Entry through HVAC systems

Depending on their design and operation, HVAC systems can influence radon levels in schools by increasing ventilation (diluting indoor radon concentrations with outdoor air); decreasing ventilation (allowing radon gas to build up); pressurizing a building (keeping radon out); or depressurizing a building (drawing radon inside). HVAC systems can transport radon from an area of high concentration to one of low concentration.

Schools may have overall indoor air quality concerns. Many schools have poor indoor air quality due in part from low rates of ventilation (low outdoor air intake). Poor air exchange can also increase concentration of common asthma triggers like mold and dust mites. The frequency and thoroughness of HVAC maintenance can also play an important role. For example, if air intake filters are not periodically cleaned and changed, this can significantly reduce the amount of outdoor air ventilating the indoor environment. Less ventilation allows radon to build up indoors. An understanding of the design, operation and maintenance of a school's HVAC system and how it influences indoor air conditions is essential for understanding and managing a radon problem. [This is also true for other indoor air quality concerns in schools.]

Environmental factors influencing radon concentrations

Seasonal and mechanical variations can affect radon concentrations. Radon levels vary constantly – daily and seasonally. In the summer, with windows and doors open and warmer temperatures, we would expect lower concentrations. During the warm months when buildings are either open or well ventilated through air conditioning, the indoor radon levels are largely determined by geologic rather than mechanical factors. Finally, room users can cause radon levels to increase by inadvertently blocking air returns, etc.

Radon varies constantly

Lowest level



SUMMER

Highest level



WINTER

Environmental effects: frost or other factors that “cap” soil

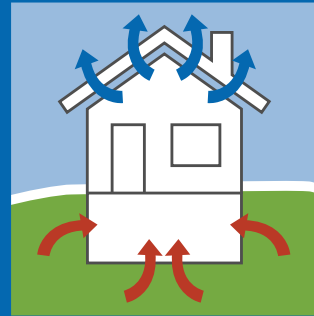

- Frost can “cap” the soil so negative pressure of buildings is exerted on larger area.
- Asphalt aprons around large buildings can have the same effect.

Rain effects

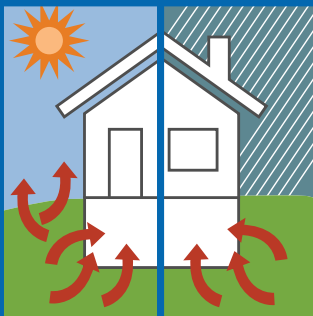

- Can “cap” the soil.
- Can displace and force soil gas into building.
- Often accompanied with barometric pressure changes.

Effects of open windows

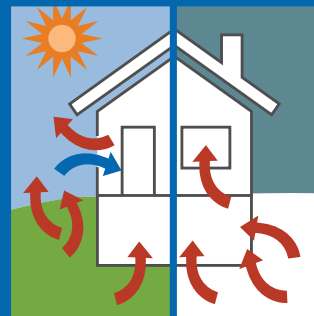

- Reduces vacuum and thereby reduces radon entry into building.
- Increases natural ventilation and radon dilution.
- Open windows do not reflect radon potential.

What rooms should be tested?

EPA's research has shown that radon levels in schools often vary greatly from room to room in the same building. A known radon measurement result for a given classroom cannot be used as an indicator of the radon level in adjacent rooms.

Therefore, per ORS 332.166-167, school radon measurement teams (i.e., personnel appointed to measure a school site for elevated radon) must, at a minimum, conduct initial measurements in all frequently occupied rooms in contact with the soil or located above a basement or a crawlspace.

School testing

- All frequently occupied rooms should be tested at the same time.
- Room examples include offices, classrooms, conference rooms, gyms, auditoriums, cafeterias and break rooms.
- A minimum of one detector for every 2,000 square feet of open floor space or portion thereof is required.

The EPA studies indicate that radon levels on upper floors are not likely to exceed the levels found in ground-contact rooms. Testing rooms on the ground-contact floor or above unoccupied basements or crawlspaces is sufficient to determine if radon is a problem in a school. Areas such as restrooms, hallways, stairwells, elevator shafts, utility closets and kitchens storage closets do not need to be tested (Note: These areas may be important areas for diagnostic testing if elevated radon is found.)

Types of radon measurement devices

There are two main categories of radon test kits:

1. Passive – do not require external power to make them work.
2. Active (continuous) – require power to function (from batteries, DC adaptors or electricity from the wall)

A passive device is recommended for school district testing. Passive devices require no electrical power to perform their function. Passive devices are exposed to indoor air by being “uncapped” or similarly activated, then left in place for a length of time, known as the measurement period.

Active devices, on the other hand, require an electrical power source. They are capable of charting radon gas concentration fluctuations throughout the course of a given measurement period (usually by producing integrated periodic measurements over a period of two or more days).

Passive devices

Activated charcoal adsorption devices (AC) are passive devices, and the charcoal within these devices has been treated to increase its ability to adsorb gases. During the entire measurement period (typically two to seven days), the adsorbed radon undergoes radioactive decay.

Like all passive devices, the average concentration calculated is subject to error if the radon concentration in a room varies substantially during the measurement period. This device does not uniformly adsorb radon during the exposure period; as a result, these test kits are not true integrating devices. ACs must be promptly returned to the laboratory period using a mail service that guarantees delivery to the laboratory within no more than two days, but **preferably overnight**. The potential for any radon gas in the envelope to “leak” surpasses this urgency.

Different types of ACs are commercially available. A device commonly used contains charcoal packaged inside an air-permeable bag. Radon is able to diffuse into this bag where it can be adsorbed onto the charcoal. Another device is a circular container filled with activated charcoal. One side of the container is fitted with a screen that keeps the charcoal in but allows air to

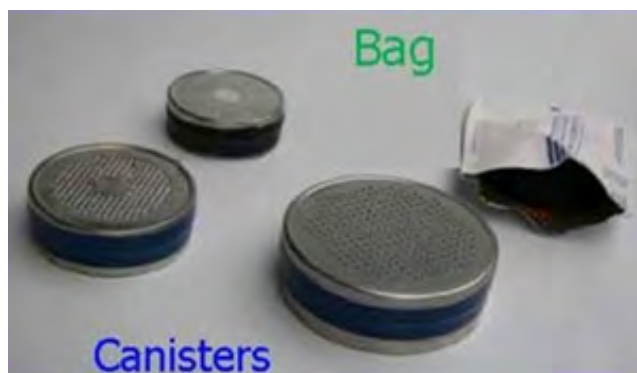

diffuse in the charcoal. Some of these devices' charcoal containers have a diffusion barrier over the opening to improve the uniformity of response to variations of radon concentration over time.

How AC kits work

- Open the container in the area to be sampled.
- Radon gas enters into the charcoal and remains trapped along with subsequent radon decay products.
- At the end of the sampling period, seal the container and send it to the lab for analysis.
- The lab counts the amount of decay from the radon adsorbed to the charcoal on a gamma detector. The lab uses this information to calculate the radon concentration.

AC detectors are deployed from two to seven days, depending on design. Because charcoal allows continual adsorption **and** desorption of radon, this method does not give a true integrated measurement over the exposure time. Use of a diffusion barrier (usually included in the test kit) over the charcoal reduces the effects of drafts and high humidity.

Advantages:

- Inexpensive
- Does not require power to operate
- Can be sent through the mail
- Can be deployed by anyone
- Accurate

Disadvantages:

- Should be analyzed by a laboratory as soon as possible after removal from building
- Highly sensitive to humidity
- No way to detect tampering
- Results biased toward last 24 hours of deployment period

Electret-ion chambers (EIC) are also passive devices. They function as true integrating detectors measuring the average radon gas concentration. EICs take advantage of the fact that radiation is emitted from the decay of radon and radon decay products impart an electrical charge on the airborne particles that are released. These charged particles or ions are attracted to an electrostatically charged disc in the EIC chamber, which reacts to their presence by losing some of

its charge. The amount of charge reduction is directly related to the average radon concentration in the chamber.

EICs may be designed to measure for short periods (typically two to seven days) or for longer periods, up to one year. The type of electret and chamber volume determine the usable measurement period. The electret is removed from the chamber and its voltage is measured with a specialized reader both before and after the measurement period. The difference between the two voltage readings is used to calculate the average radon concentration.

How they work:

- The plunger at the top is used to open and close the device. With the plunger open, the radon gas enters the main chamber through a filter, which prevents the entry of radon decay products (solids).
- The radon gas inside the chamber decays and creates electrostatically charged particles that are attracted to the charged Teflon disc. The charged particles (radon decay products) reduce the voltage on the disc by small amounts.
- The electret is removed from the chamber and its voltage is measured with a specialized reader both before and after the measurement period.
- The difference between the two voltage readings is used to calculate the average radon concentration.
- There can be both short-term and long-term electrets. These are commonly called ES (short-term) and EL (long-term). EL may be deployed for one to 12 months and ES may be deployed for two to seven days.

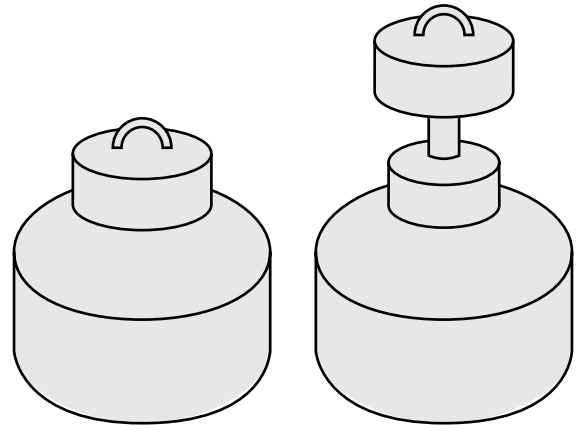

Advantages:

- Results can be given immediately
- Does not require power
- Can be reused after reading the voltages

Disadvantages:

- Sensitive to background radiation
- Sensitive to altitude
- Voltage measurements should be done at the same temperature
- Difficult to detect tampering

Alpha track detectors consist of a small piece of plastic or film encased in a container with a filter covered opening. Radon diffuses into the container and alpha particles emitted by radon and its decay products strike the detector and produce submicroscopic damage to the plastic. At the end of the measurement period, the detectors are returned to a laboratory. The damaged tracks are counted using a microscope or counting mechanism. The counted numbers of tracks are mathematically correlated to the radon concentration in air. These are most commonly used for long-term radon measurements three to 12 months in duration.

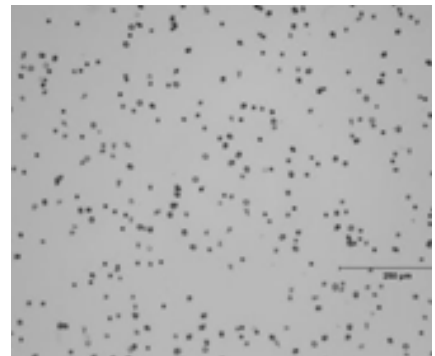
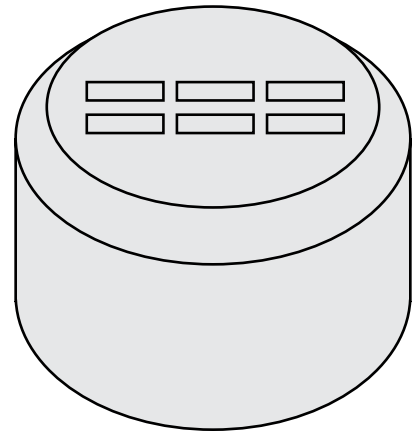

Microscopic scratches caused by radon decay products

Active devices

Active devices include the continuous radon monitors (CRM), which include a power source. The device collects air samples either mechanically or passively and uses a detection monitor to read radon concentrations. CRMs have the highest accuracy and precision over short measurement periods.

An advantage of CRMs is they record radon levels (often in one hour increments). These levels usually vary over time – sometimes greatly. Users can then review that recording to pinpoint the times of day when radon is higher in a building. HVAC systems can then be adjusted to lower those levels when a building is usually occupied, as appropriate.

These devices are expensive to buy, require ongoing annual calibration and many require specialized training to use correctly. CRMs can be costly to use in a school, particularly for initial testing, when multiple devices are necessary to test many rooms simultaneously. [CRMs can also be rented so the renter doesn't directly incur calibration costs.]

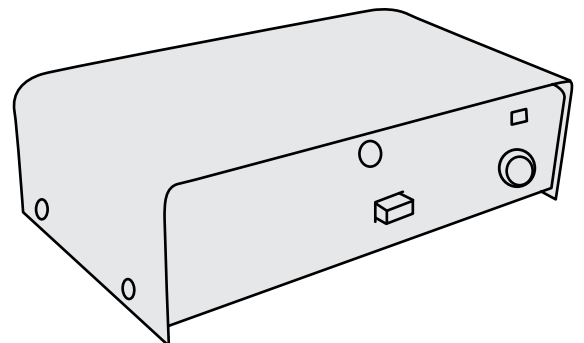
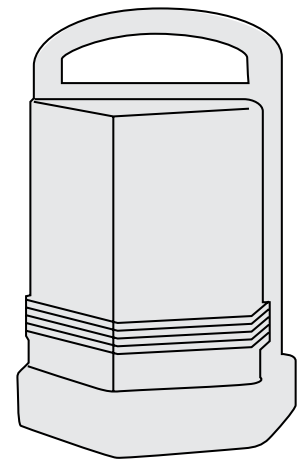

Short- and long-term tests

There are two ways to use radon test kits (passive and active) for radon testing:

- **Short-term** — A short-term test is the quickest way to test for radon. In this test, the testing device remains in an area (e.g., schoolroom) for a period of between two and 90 days depending on the device.
 - » Activated charcoal (AC) devices, which are simple to operate and place without any assistance, may be used to conduct school screening measurements. Test kits may be purchased in a hardware store, department store or home improvement store, or ordered through the mail or Internet. They can be purchased in bulk at a discounted rate. Please note: AC kits require “closed-building conditions” before/during the test, per kit instructions.
 - » Electret-ion chamber devices are also simple to operate and place, but may be more costly to purchase and operate.
- **Long-term** — A long-term test remains in place for more than 90 days. A long-term test (e.g., a test conducted over the school year) will give a result that is more likely to represent the school year average radon level in a schoolroom. Long-term tests **do not** require closed building condition.
 - » Alpha track detectors are also simple to operate and place, but are slightly more expensive and measurement results take longer to obtain.

*Short-term passive testing devices are recommended for **initial** measurements of schools.*

Measurement protocol/strategy

The short-term test is suggested to measure radon levels. In order to assure adequate test results, only use devices for a measurement period of at least 48 continuous hours when testing for radon in school buildings. The following steps should be taken:

Step 1: Initial measurements

Initial measurements should be short-term measurements of between two and seven days. These measurements should be made in all frequently occupied rooms in contact with the soil, whether the contact is slab-on-grade, a basement, a room above a crawlspace or any combination. This provides a quick test of whether or not high radon concentrations are present. Short-term test kits should be placed during colder months (October through March, depending on geographical location).

- » The building should be assessed to determine the number of measurement devices needed. See the “Quality assurance procedures for a school radon measurement program” section on [page 31](#) for information on the total number of devices, including those needed for quality assurance purposes.
- » Frequently occupied rooms include classrooms, offices, conference rooms, computer rooms, gymnasiums, auditoriums, cafeterias and break rooms. All rooms should be tested simultaneously.
- » Do not test storage rooms, kitchens, bathrooms, stairways, hallways or elevator shafts.
- » A minimum of one detector test kit must be placed for up to every 2,000 square feet of open floor area. For example, a 3,500 square-foot gymnasium would require two test kits.
- » All teachers or frequent adult users should be aware that the room is being tested.
- » Schools shall only be tested for radon during periods when the HVAC system is operating normally.
- » **“Closed-building conditions,” as discussed in the “Radon Testing Process Guide” (see Appendix A), must be observed for short-term testing.**
- » In order to get the most accurate long-term test result in a timely manner, we recommend beginning short-term testing in early October. This will allow long-term testing, if needed, to be installed by early November and picked up at the end of the school year.

Perform a follow-up measurement in every room where the initial test result is 4 pCi/L or greater.

Step 2: Follow-up measurements

If the results of a radon screening test in any frequently occupied room are found to be 4.0 pCi/L or greater, conduct follow-up measurements. The EPA and OHA recommend that follow-up testing of rooms 4.0 pCi/L or greater be conducted before any mitigation decisions are made. Follow-up testing should start quickly, ideally within one month of receiving initial test results.

Based on the results of a room's **initial** short-term test, the following steps should be conducted:

If the result is less than 2.0 pCi/L, Oregon Revised Statute 332.166-167 requires school districts to test again every 10 years.

If the result is between 2.0 pCi/L and 4.0 pCi/L, consider fixing (i.e., lowering) the radon in that room.

If the result is from 4.0 pCi/L to 8.0 pCi/L, perform a follow-up measurement of that room using a long-term test. This should be conducted over as much of a nine-month school year as possible, when the room is likely to be occupied. If that result is equal to or greater than 4.0 pCi/L, the radon in the room should be fixed (i.e., lowering).

If the initial test result is equal to or greater than 8.0 pCi/L, conduct a second short-term test and average its result with the result of the initial short-term test. If the average result of the two short-term tests is equal to or greater than 4.0 pCi/L, radon in the room should be fixed (i.e., lowering).

[A great difference in the results of the short-term tests may indicate a flaw in the testing process. Investigate and consider retesting. In situations where one of the test results is equal to or greater than 4.0 pCi/L: If the higher result is two or more times the lower result, repeat the test.]

All follow-up measurements should be made in the same locations and under the same conditions as the initial measurements (to the extent possible, including similar seasonal conditions and especially HVAC system operation). If follow-up measurements using short-term tests are done, be sure to maintain closed-building conditions. This will ensure that the two results are as comparable as possible.

The higher the initial short-term test result, the more certain you can be that a short-term test should be used rather than a long-term follow-up test. In general, the higher the initial measurement, the greater the urgency to do a follow-up test as soon as possible. For example, if the initial short-term measurement for a room is several times the radon action level (e.g., at or above 8.0 pCi/L or higher), immediately take a short-term follow-up measurement.

Use of continuous radon monitors for rooms ≥ 4.0 pCi/L after follow-up testing

CRMs may be used in these rooms to determine radon levels when the room is actually occupied. [See CRM discussion in “Types of radon measurement devices” on [page 21](#).] That may allow some fine-tuning of the room’s HVAC system to reduce those levels. Schools might consider collaborating to buy/rent a CRM, which group members could use for this purpose.

How are results interpreted?

Procedures for analyzing test results from detectors, duplicates, blanks and spikes are detailed in the “Interpreting initial results” section on [page 37](#).

- **If the follow-up test is short-term, average the results of the initial test and the follow-up. If result is 4.0 pCi/L or above, The EPA recommends that the radon concentration in that room be reduced to below 4.0 pCi/L.**
- **If the follow-up test is long-term, and the result is 4.0 pCi/L or above, the EPA recommends that the radon concentration in that room be reduced to below 4.0 pCi/L.**

It is not recommended that schools use a single short-term test to determine whether to reduce radon levels, before consulting with a certified radon professional. A follow-up measurement to confirm an initial short-term measurement of 4 pCi/L or higher should be conducted before making such a decision. In addition, EPA studies have shown that the average of two such short-term measurements reduces the possibility of misrepresenting the average radon concentration.

Is mitigation needed?

The need to mitigate will depend on radon levels found by follow-up measurements, if needed.

Oregon does not regulate or license radon mitigation professionals. The Oregon Radon Awareness Program does have a list of companies with at least one radon measurement technician on staff who has been certified by the National Radon Proficiency Program (NRPP) or the National Radon Safety Board (NRSB). That list is located at: <http://1.usa.gov/1nSvisi>.

Current listings of certified mitigation technicians by these two national non-governmental organizations can be found at www.nrpp.info and www.nrsb.org. This list should be used for informational purposes only and is not intended to be an endorsement by the Oregon Health Authority of any measurement company. These organizations are not the only sources of radon services.

The professional may perform additional diagnostic testing and ultimately may make recommendations for mitigation. Diagnostics involve the evaluation of radon entry points and the identification of the appropriate radon reduction technique. Mitigation is the design and implementation of a radon reduction strategy.

While ORS 332.166-167 does not specifically require mitigation of elevated radon, both U.S. EPA and OHA strongly suggest that rooms with follow-up measurements above 4.0 pCi/L be mitigated. Very elevated radon concentrations and site-specific considerations may suggest a quicker response rate.

What are the types of mitigation systems?

Schools and large commercial buildings are more complex than residential homes. Yet such intricacy may offer more options for reducing elevated radon. Like most other indoor air contaminants, radon can best be controlled by keeping it out of the building in the first place rather than removing it once it has entered.

It is likely impossible to reduce a school's radon to zero. Again, the goal of radon reduction is harm reduction.

Radon can be controlled through:

- HVAC systems. Adjustment to the heating, ventilation and air conditioning systems serving a room may reduce radon levels to below EPA's action level guideline of 4 pCi/L.
- Soil depressurization. A suction fan is used to produce a low-pressure field in soil under the building slab. This low-pressure field prevents radon entry by ventilating the gas outside before it has a chance to get drawn into the building.
- Building pressurization. Indoor/soil pressure relationships are controlled to prevent radon entry. More outdoor air is supplied than exhausted so the building is slightly pressurized compared to both the exterior of the building and the sub-soil area.
- Sealing entry routes. Seals are installed at major entry routes to minimize radon entry.
- Zone-specific ventilation. A building's crawlspaces, tunnels, conduits, vaults, etc. may be used to design a system that reduces its elevated radon.

For new school buildings, a cost-effective method to control radon is radon-resistant new construction (RRNC). Because a building's potential for elevated radon cannot be measured before it is constructed, specific components of a radon mitigation system (e.g., gravel layers, ventilation pipes) are installed while the building is under construction.

If, after testing, elevated radon is found in the finished building, a radon fan can easily be added and the system activated. Under current statute, RRNC is required in all public buildings (including schools) and residences built after April 1, 2013, in seven Oregon counties (Baker, Clackamas, Hood River, Multnomah, Polk, Washington and Yamhill).

For existing buildings, the most effective and frequently used radon reduction technique is adjustment of a building's HVAC system. This method directly influences radon entry by altering air pressure and dilution differences between the radon in the soil and building interior. Depending on the type and operation, an HVAC system can create positive or negative air pressure. Positive pressure can prevent radon entry, while negative pressure enhances radon entry. The positive pressure can be achieved through additional heating, cooling and/or dehumidification, along with enhanced routine operation and maintenance. A number of school districts across the country, upon finding elevated radon in just a few rooms in a school building, have lowered the radon levels in those rooms by altering the building's HVAC system.

At a certain point, however, such adjustments can reduce the effectiveness (and increase operational costs) of components in this system. Such ongoing operational costs may be greater than the upfront costs of active soil depressurization (ASD).

If adjustment of a building's HVAC system does not lower a room(s) elevated radon, a common radon reduction method is ASD. ASD is especially effective with higher levels of radon. ASD creates a lower pressure in the underlying soil to reverse the flow of air through a building foundation, thereby reducing radon entry. A series of pipes draw radon gas from underlying soil while an inline high suction fan is attached to these pipes to vent the soil gas from beneath the building foundation. ASD is accompanied by sealing radon entry routes, which improves radon removal efficiency and reduces energy costs. ASD, however, has no effect on general air quality within the building.

Radon typically enters the building from the soil through cracks and openings in the slabs and sub-structure. However, it is difficult, if not impossible, to seal every crack and penetration. Therefore, sealing radon entry routes is often used in conjunction with other mitigation techniques, and not considered a long-term solution by itself.

Planning, costs and economies of scale in school radon measurement

It is important to consider the costs associated with radon testing (labor, test kit costs, shipping, etc.) as well as what is at stake in human health. School districts should consider two important points:

- **Planning is critical** — Testing schools for elevated radon is not difficult, but it requires coordination and planning. With so many moving parts, particularly around quality assurance measures, school radon measurement teams should have a well thought-out testing plan that accounts for shipping times, school calendars, lab schedules, etc. Poorly thought-out testing efforts can lead to inaccurate results and can be costly. For example, testing efforts in school districts in other states have led to invalid results (and thousands of dollars lost) because exposed test kits didn't get to testing laboratories in time due to poor planning.

By going through a well thought-out dry-run on paper, staff will likely be able to identify timelines, costs (staff time and test kit costs) and unforeseen barriers. Knowing these before testing begins may result in more accurate test results and decreased costs.

OHA recommends (but does not require) that school radon measurement teams use the tools (“Test Kit Location Floor Plan” and “Test Kit Placement Log”) found in the “Step-by-step guide for planning radon testing in Oregon schools” in Appendix D.

- **Roving School Radon Measurement Team** — School districts, particularly smaller ones, should consider having a **roving** School Radon Measurement Team that goes from school to school in the district. Neighboring districts might consider jointly funding such a team to cover all schools in the group. Groups of schools may want to jointly buy/rent a CRM. These are particularly useful in understanding when radon levels are at their highest (so that HVAC systems can be adjusted to lower those levels when the buildings are occupied, as appropriate).

While every school is a little bit different, the procedures for testing in schools are essentially the same. A team that tests many schools will likely accumulate experience and become more efficient in measuring each school. This decreases staff time needed to coordinate timelines, place test kits and analyze results. By joining forces, districts may also be able to buy test kits (and spiking services) in bulk.

Quality assurance

Having accurate radon test results is important since mitigation can be expensive. For that reason, OHA strongly recommends that quality assurance (QA) measurements be taken to make sure that testing results are reliable. This requires the use of additional test kits.

For radon testing projects, “quality assurance” refers to maintaining the minimum acceptable standards of three concepts during the entire data collection process: precision, accuracy and bias. These are all defined below:

“**Precision**” refers to the closeness of two or more measurements to each other. In radon testing, the objective of precision is to see how close the results of two radon test kits are that have been placed side-by-side for the same measurement period. Test kits called “duplicates” are used for his purpose.

While some variation between the “detector” device and the duplicate kit paired with it is expected, an unusually large variation in the results of the two tests may indicate a systematic problem in the measurement process for a building. Using duplicates to determine precision is discussed in the “Quality assurance procedures for a school radon measurement program” section on [page 31](#).

“**Accuracy**” is defined as how close the measured value is to the actual value. In other words, were test kits on the site measuring anything other than the radon at the school site? In radon testing, test kits called “blanks” are used to determine whether the manufacturing, shipping, storage or processing has affected the accuracy of the testing process for a site. Using blanks to determine accuracy is discussed in the “Quality assurance procedures for a school radon measurement program” section on [page 31](#).

“**Bias**” is defined as amount of systematic error inherent to the testing process, including potential test kit defects and quality defects of the testing laboratory (i.e., the kit manufacturer to which the kit is returned after use for processing). Test kits called “spikes” are used to determine measurement laboratory and test kit accuracy. Using spikes to determine bias is discussed in the “Quality assurance procedures for a school radon measurement program” section on [page 31](#).

Types of test kits used in quality assurance for radon testing

- 1. Duplicates:** Duplicates provide an indication of the precision of the measurement. Duplicates are test kits that are placed in the same location alongside the kits used as detectors for the same measurement period.

The number of duplicates should be 10 percent of the rooms to be tested at a school site.

A minimum of one duplicate per building is needed. [Round up if a fraction. For example, a school has 55 rooms to be tested. Ten percent of those equals 5.5 test kits. But the team should request six kits for spiking.]

- 2. Blanks:** Blanks can be used to determine whether the manufacturing, shipping, storage or processing of the test kit has affected the accuracy of the measurements. They are called blanks because they are placed alongside opened detectors but then immediately resealed. As a result, blanks should have results at or close to 0.0 pCi/L.

The number of blanks should be five percent of the rooms to be tested at a school site; round up if a fraction. A minimum of one blank per building is needed.

- 3. Spikes:** Spikes evaluate how accurately the detectors supplied by a radon testing laboratory measure radon and the accuracy of that lab's kit processing. Spike testing involves exposing kits to known levels of radon in a certified performance test chamber. Currently, there are two chambers (Bowser-Morner Inc. and Radon Measurement Lab) certified by AARST-NRPP (<http://aarst-nrpp.com/wp/test-chambers/>) to provide spiking services. Those spikes are returned to the School Radon Measurement Team, which sends them (unidentified) to the radon testing laboratory.

The number of spikes should be three percent of the rooms to be tested at a school site; round up if a fraction.

Developing a device placement and floor plan is recommended for each school building to be tested. The serial numbers and locations for devices placed on the site (detector, duplicate and blanks) should be included in the device log. The School Radon Measurement Team should retain the logs, but time and date data is copied to/sent along with the kits to the radon measurement laboratory.

Quality assurance procedures for a school radon measurement program

Please read this **entire** section before starting testing. Some steps are time-dependent. All should be done as part of well-planned testing effort. (10)

1. As discussed above, a School Radon Measurement Team should calculate how many detector kits are needed. This number equals the number of regular rooms that are to be measured plus those kits required for larger rooms (2,000 square feet or larger). Larger rooms need one test kit per 2,000 square feet or portion thereof, so a 3,500 square-foot gymnasium needs two detector kits.
2. In addition to those detectors, kits for quality assurance (QA) purposes should be purchased in the following proportions: duplicate kits (a number equal to 10 percent of the rooms to be tested at a school site); blank kits (5 percent of the rooms to be tested at a school site); and spike kits (3 percent of the rooms to be tested at a school site). Note: Each building to be tested should have, in place, a **minimum** of one duplicate and one blank.

Important: Test kit percentages for QA are based on the number of **rooms** to be tested, **not** the number of detector kits to be used.

3. After determining the number of test kits (detectors, blanks, duplicates and spikes) needed for initial measurement of school site(s), kits should be purchased from one manufacturer (and be from one lot). It is most cost-effective to purchase in bulk.
4. Once the kits are received, team staff should **randomly** draw the kits needed for spiking (the 3 percent) from the boxes. The serial numbers of the kits should be recorded, noted as the kits being reserved for spike testing and set aside.
5. For radon measurements of a **single** school site:
 - a. Approximately two weeks before testing is to start, the team should contact a certified performance test chamber to discuss spiking services (<http://aarst-nrpp.com/wp/test-chambers/>). Team should inquire about and understand the chamber's schedule for spiking the kits and express mailing them back to the sender. A school's testing timeline may depend on that schedule.
 - b. Send kits to the certified performance test chamber for spiking. The chamber should return those spiked kits via overnight delivery to the team so that their arrival coincides with the end of the school's measurement period. Spikes can then be included in the same container as the detectors, blanks and duplicate kits (but not identified as spikes) and shipped overnight back to the radon measurement laboratory.

6. For radon measurements of **multiple school sites**:
 - a. Approximately a month before testing is to begin, the team should contact a certified performance test chamber (<http://aarst-nrpp.com/wp/test-chambers/>) to discuss the chamber's spiking schedule and arrange ongoing spiking services for the duration of the testing project.
 - b. With spiking service arrangements in place, the team should mail the kits designated for spiking (the 3 percent) to the chamber. Now the team has a bank of kits at the chamber waiting to be spiked. At the team's request (see above, "Quality assurance procedures for a school radon measurement program," step 5 on [page 31](#)), the chamber will spike the requested number of banked kits with a known amount of radon (spiked), and express mail them to the team along with documentation on that known level.
 - c. The team will know in advance the date that the devices (detectors, blanks and duplicates) deployed at a particular school site are to be picked up. The team should contact the chamber with which it has banked test kits for spiking and request that a specific number of spiked test kits be sent to a particular school site so their arrival **coincides** with the end of that school's measurement period. Spikes can then be included in the same container as the detectors, blanks and duplicate kits (but not identified as spikes) and shipped overnight back to the radon measurement laboratory.
7. In two to four weeks, the team will receive results for all the test kits analyzed. Please see "Interpreting initial results" on [page 37](#) for procedures to analyze and apply the test results.

Radon testing process guide

The first step of conducting initial screening measurements is to identify rooms that have potentially elevated radon levels (e.g., levels of 4.0 pCi/L or greater) during the occupied school year.

1. As suggested, prepare a “**Test Kit Placement Log**” and a “**Test Kit Location Floor Plan**” for each school in which radon measurements are made. Use the school’s emergency escape map as the floor plan, since it usually provides the most accurate and up-to-date information.

Accurately record the test kit location on both a log and floor plan. See the sample “Test Kit Placement Log” and the “Test Kit Location Floor Plan” in Appendix D for reference.

2. Test kits or testing services must meet the current requirements of the national certifying organizations, National Radon Proficiency Program (NRPP, www.nrpp.info) or the National Radon Safety Board (NRSB, www.nrsb.org). Testing must follow the directions on the test kit.
3. You must determine the number of test kits needed to measure radon (detectors) by counting the number of appropriate rooms. One detector kit is used for each room that is 2,000 square feet or less. Use additional test kits for larger rooms. [See “What rooms should be tested?” section, [page 17](#).]
4. Add the test kits needed for quality assurance purposes to this number [see “Quality assurance procedures for a school radon measurement program” section on [page 31](#).]
5. Place test kits in all rooms in contact with the soil or located above a basement or a crawlspace that are frequently occupied by students and school staff. [See “Test Kit Placement Guide” in Appendix A.]
6. Ensure that testing occurs during when students and teachers are normally present (during weekdays).
7. In addition to placing detectors, provide additional test kits to serve as quality control measures (duplicate, blank and spike measurements). [See “Quality assurance” section starting on [page 29](#).]

Place kits designated as blanks and duplicates using the “Test Kit Placement Guide” in Appendix A.

Spike test kits are **not** physically placed on site, but are used for quality assurance purposes. Ordering spikes from a certified performance test chamber (and their delivery) should coincide as closely as possible with the date testing stops and detectors, duplicates and blanks are picked up so **all** kits can be mailed to the radon measurement laboratory. [See “Quality assurance measurements for a school radon measurement program” on [page 31](#).]

8. Note all test kits placed in the school site (detectors, duplicates and blanks) by their serial number on the “Test Kit Placement Log” and “Test Kit Location Floor Plan.”
9. Place test kits:
 - a. Where they are least likely to be disturbed or covered up;
 - b. At least three feet from doors, windows to outside or ventilation ducts;
 - c. At least one foot from exterior walls;
 - d. Between 20 inches and six feet from the floor;
 - e. Approximately every 2,000 square feet for large spaces (e.g., a 3,500 square-foot gymnasium would require two test kits).

Using the five-item placement protocol above, the school radon measurement team can simply **place the test kit on the teacher’s desk** or on a bookshelf, out of the way of students.

To prevent tampering (like at elementary schools), kits may be suspended from a wall or ceiling (using string and thumb-tack/tape). If they are suspended, they should be between 20 inches and six feet above the floor, at least one foot below the ceiling.

10. Test kits must **not** be placed:
 - a. Near drafts resulting from heating, ventilating vents, air conditioning vents, fans, doors and windows;
 - b. In direct sunlight;
 - c. In areas of high humidity such as bathrooms, kitchens or laundry rooms;

- d. Where they may be disturbed at any time during the test.
11. You must use short-term test kits under closed conditions (closed windows/doors except for normal exit/entry).
 - a. Closed conditions: Complete short-term tests under closed conditions in order to obtain more representative and reproducible results. Open windows and doors permit the movement of outdoor air into a room. When closed conditions in a room are not maintained during testing, outdoor air may dilute radon gas and result in a measurement that falls below the action level in a room that actually has a potential for an elevated radon level. Only test schools shall for radon when the HVAC system is operating normally.
 - b. All external doors should be closed except for normal use. Repair any structural and weatherization defects prior to testing.
 - c. Verify closed conditions when placing and retrieving test kits.
 12. Place short-term test kits during colder months (October through March) depending on geographical location.
 - a. Colder months: It is important to test under closed conditions to obtain meaningful results from short-term tests. As a result, schools should schedule testing during the coldest months when windows and exterior doors are more likely to be closed and the heating system is likely operating. This usually results in less intake of outside air. Studies of seasonal variations of schools' radon measurements found that short-term measurements may more likely reflect the average radon level in a room for the school year when taken during the winter heating season. Fortunately, this is when most schools are in session.
 - b. Check and document local weather forecasts prior to placing test kits. Do not conduct short-term measurements (between two and five days) during severe storms or periods of high winds. The definition of severe storm by the National Weather Service is one that generates winds of 58 MPH and/or three-quarter-inch diameter hail and may produce tornadoes.
 13. Place test kits during weekdays with HVAC systems operating normally.
 - a. Weekday testing: Do short-term (two to five-day) testing on weekdays. The actual length of time a kit is deployed depends on the manufacturer's instructions.

Suggested timeline:

Monday morning – Place kits (detectors/duplicates/blanks) per “Test Kit Placement Log” created for school. Record data, as needed, on log.

Thursday morning – Pick up kits, record as needed, ship with (previously requested & received) spiked test kits to radon measurement laboratory.

- b. Air conditioning systems that recycle interior air may be operated.
 - c. Window air conditioning units may be operated in a re-circulating mode, but must be greater than 20 feet from the test kit.
 - d. Ceiling fans, portable humidifiers, dehumidifiers and air filters must be more than 20 feet from the test kit.
 - e. Portable window fans should be removed or sealed in place.
 - f. Fireplaces or combustion appliances (except for water heaters/cooking appliances) may not be used unless they are the primary source of heat for the building.
14. If radon mitigation systems are in place in the school, they should be functioning.
15. Schools should avoid conducting initial measurements under the following conditions:
- a. During abnormal weather or barometric conditions (e.g., storms and high winds). If major weather or barometric changes are expected, it is recommended that the two- to five-day testing be postponed. EPA studies show that barometric changes affect indoor radon concentrations. For example, radon concentrations can increase with a sudden drop in barometric pressure associated with storms.
 - b. During structural changes to a school building and/or the renovation of the building's envelope or replacement of the HVAC system.

Follow-up measurements

Follow-up testing (in rooms with initial short-term measurement of 4.0 pCi/L or higher) should start within one month after receiving the initial test results. Follow-up testing must be made in the same location in a room. Conducting follow-up testing using short-term methods should be done in the same conditions as the initial measurement. Follow-up testing using passive short-term test kits should follow the same quality assurance procedures and requirements (i.e., percentages of duplicates/blanks/spikes). Follow directions under “Radon Test Placement Protocol Checklist” and record test kit placement.

Interpreting initial results

1. Review the results of the initial testing and highlight any results that are at or above 4.0 pCi/L.
2. For the detector kits that had duplicate kits paired with them, compare the results of the two kits by calculating the relative percent difference (RPD).

$$\text{Relative percent difference (RPD)} = \frac{\text{Initial result} - \text{duplicate result} \times 100\%}{\text{Average of both results}}$$

If results are:	Expected range	In control	Warning	Out of control
2.0–3.9 pCi/L	0–25%	0–49%	50–67%	> 67%
≥ 4.0 pCi/L	0–14%	0–27%	28–36%	> 36%

If a result over 4.0 pCi/L differs by 28 percent or more, the data quality should be questioned.

In this case, you should call the radon measurement lab to investigate the situation further. The room associated with the questionable duplicate may need to be retested. If the lab doesn't provide a satisfactory answer, a team representative should discuss it with a radon measurement professional.

3. Review the results of the blank test kits sent for analysis. Results should be very close to 0.0 pCi/L. If they are not, call the the radon measurement lab to investigate further. If unresolved, a team representative should contact a radon measurement professional.
4. Check to be sure that the spike results are accurate by calculating how close the measured value (i.e., detector kit result) is to the reference value (i.e., spike value reported back by certified performance test chamber). Calculate the relative percentage error (RPE) for each spike.

$$\text{Relative percentage error (RPE)} = \frac{(\text{Measured value} - \text{reference value}) \times 100\%}{\text{reference value}}$$

The result of each spike can then be put in one column or plotted on a chart.

How to use spike testing results

The purpose of spike testing is to ensure that bias is not influencing a site's test results. Yet one spike result that's outside the control limit does not mean that the school site's test results are completely off. In general, one should look for a **trend** in the values in the percent difference column/table.

Relative percent error (RPE)	Expected range of variability	In control	Warning	Out of control
	Between +10% and -10%	Between +20% and -20%	Between +30% and -30%	Outside of +30% and -30%

A trend in RPE values that are more than $\pm 30\%$ should be investigated.

In that case, the team's storage, handling and kit placement should be reviewed. At the same time, the radon measurement lab should be contacted and the RPE result(s) discussed so that the lab can review its own procedures. A team representative should contact a radon measurement professional to discuss.

Interpretation of follow-up test results

Perform the same quality assurance calculations done for initial testing. Questions about discrepancies in quality assurance results should be directed to a radon measurement professional.

Report of results and distribution

ORS 332.166-167 requires that school districts make all test results available: to the district's school board; the Oregon Health Authority (to post on its website) and to parents, guardians, students, school employees, school volunteers, administrators and community representatives at the school or district office or website.

Radon measurement professionals

Questions about the quality assurance discrepancies listed above should be directed to a radon measurement professional.

Oregon does not regulate or license radon measurement professionals. The Oregon Radon Awareness Program has a list of companies with at least one radon measurement technician on staff certified by the National Radon Proficiency Program (NRPP) or the National Radon Safety Board (NRSB). That list is located at <http://1.usa.gov/1Vhijhx>.

Current listings of certified measurement technicians by these two national non-governmental organizations can be found at their respective websites, www.nrpp.info and www.nrsb.org.

This list is for informational purposes only and is not intended to be an endorsement by the Oregon Health Authority of any measurement company. These organizations are not the only sources of radon services.

After receiving results of follow-up testing

The EPA, OHA Oregon Radon Awareness Program and numerous non-governmental groups recommend that the school district take action to reduce the radon level in those rooms where the average of the initial and follow-up short-term kit results OR the result of the long-term kit used in follow-up is 4.0 pCi/L or more.

Although not required of school districts under ORS 332.166-167, it is recommended that school administration direct appropriate staff to adjust the building's HVAC system and then retest. If this doesn't reduce the radon below 4.0 pCi/L, school districts can hire a radon mitigation professional to reduce elevated radon levels identified through testing.

When should periodic retesting be done?

Initial testing should be conducted in accordance with ORS 332.166-167 before Jan. 1, 2021. Because buildings age and ground beneath them settles, radon entry may increase due to cracks in the foundation. For that reason, ORS 332.166-167 requires that schools be tested once every 10 years regardless of initial testing results or whether mitigation was done.

Suggested times for retesting, in addition to that required under ORS 332.166-167, are as follows:

1. Current national guidelines (1) recommend that school buildings be re-tested every five years.
2. If radon mitigation measures have been implemented in a school, retest these systems as a periodic check to ensure that the radon mitigation measures are working. The EPA does not provide a specific interval, but OHA **recommends** that schools with radon mitigation measures retest every five years.
3. Retest after major renovations to the structure of a school building or after major alterations to a school's HVAC system. These renovations and alterations may increase radon levels within a school building.
4. If major renovations to the structure of a school building or major alterations to a school's HVAC system are planned, retest the school before initiating the renovation. If elevated radon is present, radon-resistant techniques can be included as part of the renovation.

Please direct questions to:

Oregon Radon Awareness Program

971-673-0440

radon.program@state.or.us

www.healthoregon.org/radon

References

1. American National Standards Institute/American Association of Radon Scientists and Technologists. Protocol for conducting measurements of radon and radon decay products in schools and large buildings, 2014 [national radon standards].
2. U.S. Surgeon General. Surgeon general releases national health advisory on radon. 2005. U.S. Health and Human Services press release, Jan. 13, 2005 [cited 2016 May 9]. Accessed at URL: www.adph.org/radon/assets/surgeon-general-radon.pdf.
3. American Cancer Society. Cancer facts & figures 2015. American Cancer Society. Atlanta: American Cancer Society; 2015 [cited 2016 May 3]. Accessed at: URL: www.cancer.org/acs/groups/content/@editorial/documents/document/acspc-044552.pdf.
4. Siegel RL, Miller KD, Jemal A. CA: A cancer journal for clinicians. 2015 Jan; 65 (1): 5–29.
5. Field RW. Breathing easier: an informational radon video for physicians. [ND] [cited 2016 May 10]. Accessed at: URL: <http://canceriowa.org/BreathingEasier.aspx>.
6. National Research Council. Health effects of exposure to radon. 1999. Committee on Health Risks of Exposure to Radon (BEIR VI), Board on Radiation Effects Research, Commission on Life Sciences, National Research Council, National Academy Press, Washington, D.C.
7. Environmental Protection Agency. Radon measurement in schools revised edition. USEPA Air and Radiation (EPA 402-R-92-014) 1993 July.
8. Klepeis NE, Nelson WC, Ott WR, Robinson JP, Tsang AM, Switzer P, Behar JV, Hern SC, Engelmann WH. The national human activity pattern survey (NHAPS): a resource for assessing exposure to environmental pollutants. *J Expo Anal Environ Epidemiol* 2001 May–Jun;11(3):231–52.
9. Environmental Protection Agency. National residential radon survey: summary report. USEPA (EPA 402/R-92/011. 1992 October.
10. Ohio Department of Health Bureau of Environmental Health and Radiation Protection Radon Licensing Program. [Adapted from:] School radon testing checklist 2015 [cited 2016 May 10]. Accessed at: URL: www.odh.ohio.gov/~media/ODH/ASSETS/Files/eh/school_environmental_health/schoolradontestingchecklist.pdf.
11. Burkhart JF. Radon Measurement Lab (RML), 2015.

Websites

School staff, parents and students may be interested in additional information on radon. The Oregon Radon Awareness Program suggests the following radon websites:

[Environmental Protection Agency \(EPA\) \[www.epa.gov/radon\]](http://www.epa.gov/radon)

EPA's main page is on everything radon.

[EPA's radon in schools page \[www.epa.gov/radon/radon-schools\]](http://www.epa.gov/radon/radon-schools)

[National Radon Program services \[www.sosradon.org\]](http://www.sosradon.org)

This EPA-funded program is nationally recognized leader in radon education.

[National Cancer Institute's radon page \[www.1.usa.gov/1qGOOtM\]](http://www.1.usa.gov/1qGOOtM)

[Oregon Field Guide: radon \[http://bit.ly/1SLRgWC\]](http://bit.ly/1SLRgWC)

This 12-minute episode, from Oregon Public Broadcasting, provides an excellent introduction on why elevated radon is a concern in Oregon.

[Oregon Health Authority's frequently asked questions on radon](http://www.healthoregon.org/radon)

[\[www.healthoregon.org/radon\]](http://www.healthoregon.org/radon)

In addition to FAQs, OHA's main radon page has information on radon risk in Oregon and how homes can easily be tested.

Glossary

Action level: The designated measurements at or above which consumers should take action to reduce radon levels.

Blanks: Measurements made by analyzing unexposed (closed) detectors that accompanied exposed detectors to the field. School districts use blanks to assess if any change in analysis is caused by anything outside the immediate room conditions being tested. Background levels may be due to leakage of radon into the detector, detector response to gamma radiation or other causes.

Carcinogen: A dangerous substance that is directly involved in the contraction of cancer.

Closed-building condition: Keeping all windows and doors closed except for normal entry and exit, and not operating fans or other machines that bring in air from outside. Fans that are part of a radon-reduction system or small exhaust fans operating for only short periods of time may run during the test.

Duplicates: Duplicate measurements provide a check on the precision of the measurement result and allow the user to make an estimate of the relative precision. Large precision errors may be caused by detector manufacture or improper data transcription or handling by suppliers, laboratories or technicians performing placements. Precision error can be an important component of the overall error. The precision of duplicate measurements are monitored and recorded as quality records.

Long-term test: A radon testing kit that is designed for a long testing period usually in excess of 90 days.

Mitigation: A process used to remove high levels of radon from a home, residence, school or business.

Picocuries per liter (pCi/L): A unit of measurement. It specifies the decay in seconds within a volume of one liter of air.

Quality assurance: A process designed to produce test results that can serve as a standard.

Radon: A harmful gaseous radioactive decay product of radium.

Short-term test: A radon testing kit that is designed for a short testing period anywhere from a two- to 90-day period.

Spikes: Measurements used to assess the accuracy of a lab analysis and/or how accurately detectors supplied by a laboratory (i.e., test kit manufacturer) measure radon. Spikes are test kits that have been exposed to a known concentration of radon in a chamber approved by the National Radon Proficiency Program (NRPP) or National Radon Safety Board (NRSB). The process for completing this aspect of a radon measurement effort’s quality assurance/quality control plan is laid out in the “Radon Test Placement Protocol Checklist” in Appendix A.

Appendix A: Radon test placement protocol checklist

Note: This document has been prepared to help schools and school districts conduct radon measurements in schools. The step-wise approach is aimed at helping school districts determine where to test, how many test kits are required, where to place test kits, and proper documentation of the process. This document is thus meant to be used as a general guideline, not a mandate. Each school will present a different situation. If specific questions or issues arise regarding testing in your school, contact the Oregon Radon Awareness Program at 971-673-0440 or email radon.program@state.or.us.

Important: Order all radon test kits for initial measurement at the same time. Kits should all be from the same manufacturing batch.

Test Kit Placement Guide

Once the number of test kits is determined, they need to be placed in the frequently occupied rooms as identified in the “What rooms should be tested?” section on [page 17](#).

1. Be sure to check these items before placing the radon test kits:
 - Closed building conditions have been maintained in the building for 12 hours.
 - HVAC system is operating as it normally would when students and faculty are present.
 - Testing is being done during a time that students and faculty are present.
2. As detectors are placed in the rooms, determined thorough and accurate data needs to be recorded on the device log and floor plan (see samples in Appendix D).

Protocol for all test kits include the following. Be sure that each detector placed is:

- In a location where it will be undisturbed;
- Out of direct sunlight;
- Three feet from all doors and windows;
- Four inches from all other objects;

- At least one foot from all exterior walls;
- At least 20 inches to 6 feet from the floor;
- Out of direct air flow from vents;
- Four feet from the heat source.

School measurement teams in other states simply place the test kit on the teacher's desk or out of the way of students on a bookshelf.

3. Specific protocol for duplicate measurements. If the test kit you are placing is a duplicate measurement also be sure to:
 - Place duplicate (side-by-side) test kit four to five inches away from test kit for that room
4. Specific protocol for blank measurements. If the test kit you are placing is a blank measurement, also be sure to:
 - Unwrap blanks and open, but then immediately close and reseal them.
 - Place the test kit next to the detector kit(s) for the room four to five inches away.
5. Specific protocol for spiked test kits.
 - Arrange for the spiked test kits to arrive back from the Certified Performance Test Chamber to the School Measurement Team as close as possible to the day that kits are retrieved from the school. [See "Quality assurance procedures for a school radon measurement program" on [page 31](#).]
6. Testing period.

The test kits should be left out no less than 48 hours but no more than seven days. [It's best to follow test kit manufacturer's instructions for more specific recommendations.] It's best if devices are left in place for four days to ensure optimum results.

Many schools place short-term kits on Monday morning and pick them up on Thursday morning.

Retrieving kits. Once the testing period has ended, all test kits placed at a school site (detectors, duplicates and blanks) need to be retrieved. This should be done on the same date. Complete the data sheet when retrieving detectors.

- Record the ending date and time that the kits were picked up per the “Test Kit Placement Log” [Appendix D].
- Record ending information on the test kit package (if required).

7. Prepare and mail all kits.

- Follow the manufacturer’s instructions to seal and prepare test kits to be mailed to the lab.
- Include those spiked kits (not identified as such) in the same box(es) as other kit types.
- Mail all test kits (detectors, duplicates, blanks, spikes) to the radon measurement laboratory specified on the test kit. Use a mail service that guarantees delivery to the laboratory within two days at maximum, but **preferably overnight**.

Appendix B: Signage for school radon measurement

Below is a sign that that school radon measurement teams may use, as needed, to let school staff, parents and students know that measurement for elevated radon in the school is taking place.

DO NOT TOUCH! RADON TEST IN PROGRESS

This is a screening test for the Sample School District #123. The radon detector should not be disturbed. Windows should remain closed and the radon detector will be picked up on _____.

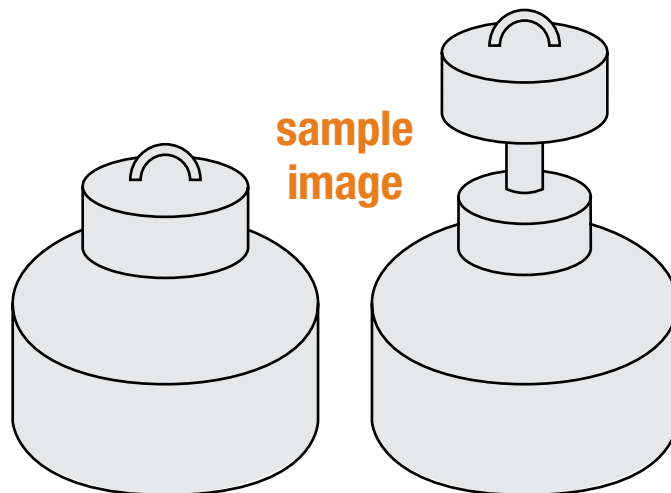

The Sample School District #123 is testing for radon. Radon is a colorless, odorless, naturally occurring radioactive gas that comes from uranium in the soil and can cause lung cancer. The surgeon general has warned about the health risk from exposure to radon in indoor air. The Surgeon General urged Americans to test their homes because radon is the leading cause of lung cancer for non-smokers in the United States and breathing it over prolonged periods can present a significant health risk. The U.S. Environmental Protection Agency (EPA) estimates that approximately 21,000 lung cancer related deaths occur annually in the United States with about 275 of those in Oregon.

Because of the danger of radon, every occupied school building in all Oregon school districts shall be tested every 10 years for radon per ORS 332.166-167.

For questions about this test, contact: _____

Appendix C: Memo to parents and staff about radon measurement

Before radon measurement begins, schools may want to notify parents and school staff of the effort. Below is an example memo that can be customized.

[EXAMPLE of a memo to be sent to school staff and parents before testing begins]

To: _____ Date: _____

From: Principal or Superintendent

Re: Radon testing

An important step is being taken to ensure that the buildings of [insert name of school] are healthy and safe.

This is to notify you that initial testing for elevated radon at [insert name of school] will be conducted starting [insert date]. Under a 2015 Oregon law (ORS 332.166-167), Oregon schools must be initially tested for elevated radon on or before Jan. 1, 2021.

The radioactive gas, radon, is the number-one cause of lung cancer among non-smokers, according to EPA estimates. Elevated radon is found naturally in soil across the country and under all types of structures (including homes).

To test for elevated radon at [insert name of school], small devices will be placed in each of the occupied rooms that are in contact with the ground starting [date]. These devices will be picked up on [date]. Test results will be available at the district office on or around [approximate dates].

The test devices look like [describe: 1) for example, a small black cylinder (also known as an alpha track) about 1-1/2 to 2 inches across; 2) for charcoal adsorption: cardboard envelope packet; 3) etc. A picture can be inserted here]. Devices may be placed in somewhat hidden locations, where possible. Please do not tamper with or move test kits, and keep exterior windows and doors closed (except for normal entry/exit) during the testing period.

While occupants may be exposed to elevated levels of radon in schools, current data from the United States Environmental Protection Agency (EPA) suggests radon exposure at home is the number-one source of radon exposure for most people. The EPA and the Oregon Health Authority (OHA) recommend that **all** homes, regardless of location and type, be tested.

Please see OHA's Frequently Asked Questions about radon, including information on the health effects, at www.healthoregon.org/radon. Information on how homes can be tested easily and inexpensively is also found at this website. You can request printed information on radon by contacting OHA's Radon Awareness Program at 971-673-0440 or radon.program@state.or.us.

If you have further questions or concerns regarding radon testing at [insert name of school], please feel free to contact [name, such as health and safety coordinator] at [phone or email].

Thank you, in advance, for your cooperation.

Appendix D: Step-by-step guide for planning radon testing in Oregon schools

Per ORS 332.166-167, Oregon school districts shall develop a plan for testing schools under their jurisdiction for elevated levels of radon. They shall submit it to the Oregon Health Authority on or before **Sept. 1, 2016**.

Below is a recommended step-by-step guide for planning for radon testing at a specific school site. It's intended to be used with the other information in this document.

By going through well thought-out “dry-run” on paper, staff (e.g., school radon measurement teams) will likely be able to identify timelines, costs (staff time and test kit costs) and unforeseen barriers. Knowing these, before testing begins, may result in more accurate test results and decreased costs.

1. Identify rooms to be tested

ORS 332.166-167 specifies that “at a minimum, any frequently occupied room in contact with the ground or located above a basement or a crawlspace” should be tested.

Examples of such rooms include offices, classrooms, computer rooms, conference rooms, gyms, auditoriums, cafeterias and break rooms. This does not mean storage rooms, bathrooms, stairways, hallways, kitchens or elevator shafts.

Staff should procure a copy of the school’s emergency escape map. It can be used as the floor plan, since it usually provides the most accurate and up-to-date information. The map can be used to identify the frequently occupied rooms at a particular school site. As discussed below, that map can also be used to indicate which test kit types will go in which room.

Make sure all rooms in the building floor plan are individually labeled; create labels for them if they are not.

2. Determine the number of test kits needed.

- a) Count all frequently occupied rooms, as defined in ORS 332.166-167.

At the end of section 2a) you should have a rough list of rooms that need to be tested.

_____Number of rooms

- b) Determine if any of the rooms selected are larger than 2,000 square feet.

If YES, how many?

Determine the number of test (detectors) kits needed to test the entire school site:

_____ (Total number of rooms after section 2a).

_____ (Number of rooms over 2,000 square feet).

_____ (Number of rooms over 4,000 square feet).

_____ (Number of rooms over 6,000 square feet).

TOTAL _____ Number of detector kits needed to test the school site

3. Determine the number of quality control measurements needed

- a) Determine the number of **duplicate** measurements that need to be deployed during measurement. Rooms to be tested x 0.10 (10%) = _____
[NOTE: Round up to the next whole number. Remember, a minimum of one duplicate kit per building.]
- b) Determine the number of **blank** measurements that need to be deployed during measurement. Rooms to be tested x 0.05 (5%) = _____
[NOTE: Round up to the next whole number. Remember, a minimum of one blank kit per building.]
- c) Determine the number of **spike** measurements that need to be deployed during measurement. Rooms to be tested x 0.03 (3%) = _____
[NOTE: Round up to the next whole number.]

4. Determine total number of test kits needed to perform all required tasks.

_____ Number of detector kits determined in Section 2.

_____ Number of duplicate tests determined in Section 3a.

_____ Number of blank tests determined in Section 3b.

_____ Number of spike tests determined in Section 3c.

TOTAL _____ **Number of test kits needed to test the school site**

5. Use a “Test Kit Location Floor Plan” to create a “Test Kit Placement Log(s)”

The school radon measurement teams can use a template of the school’s emergency escape plan to decide in which rooms the different types of test kits (detectors, blanks and duplicates) will be placed. These documents will guide the planning of a radon testing effort as well as the actual testing itself.

The school floor plan (see example below) is used to create “Test Kit Placement Log(s)” [see example on [page 54](#) and template on [page 57](#)] for the school, which indicates where the detectors, duplicates and blanks are to be placed when initial testing of the school for elevated radon begins.

Important: Because each building on a school site should have a minimum of one detector, one duplicate and one blank, a separate “Test Kit Placement Log” should be created for each building on the school site.

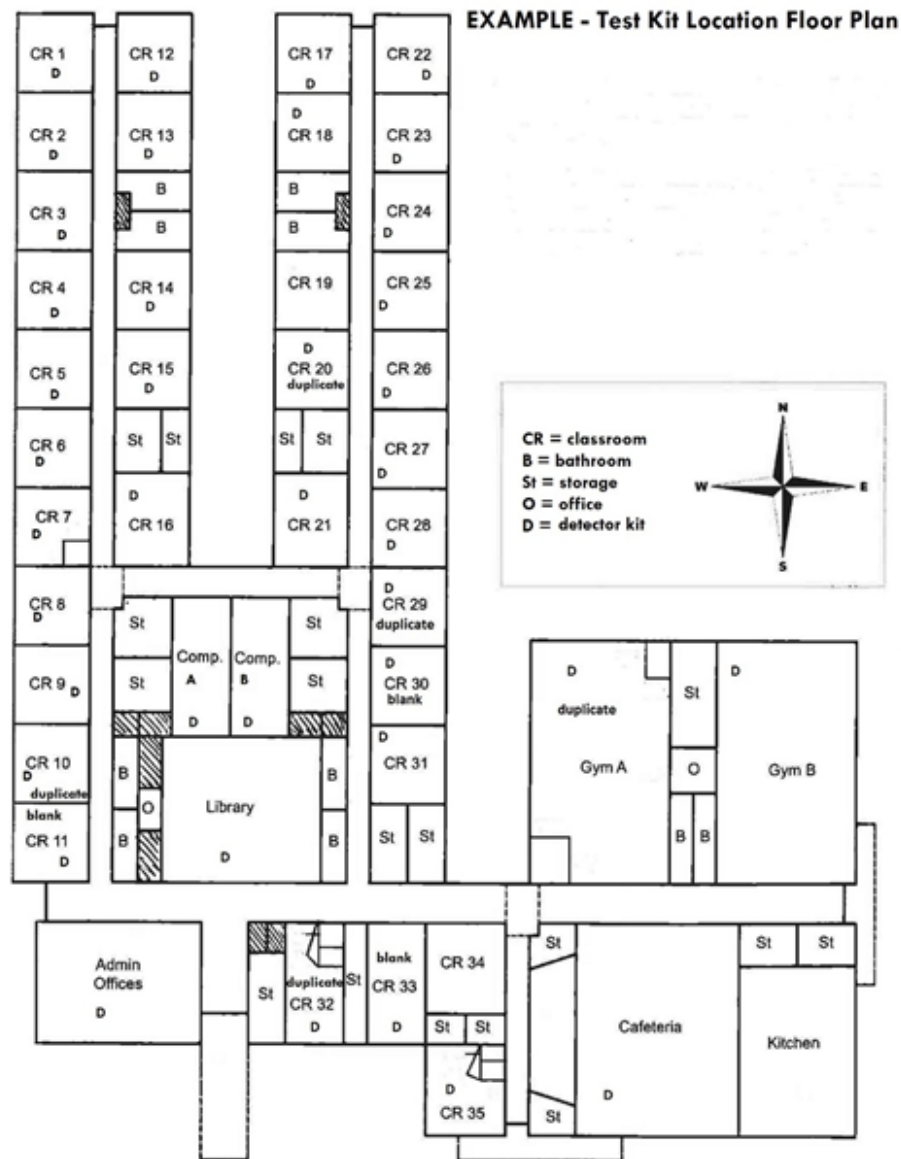

Test Kit Placement Log Example

An example of the “Test Kit Placement Log” is on [page 54](#). It is based on the example “Test Kit Location Floor Plan” on [page 52](#). The log created for a school will be used for both planning the placement of test kits and recording data when testing of the school actually takes place. A blank “Test Kit Placement Log” (see [page 57](#)) can be used, along with the “Test Kit Location Floor Plan” template, found on [page 56](#).

Directions: Using a school’s “Test Kit Location Floor Plan,” please indicate in the log’s room description column the rooms that will have detectors (D), blanks and duplicate test kits. These should be selected per the guidance in the “What rooms should be tested?” section ([page 17](#)) and the “Quality assurance procedures for a school radon measurement program” section on [page 31](#) of this protocol. On the far right of the log, please indicate the “Type of test” (for that row).

[Although the “Test Kit Placement Log” has rows reserved for the 10 percent of rooms at a school site where duplicates should be placed (yellow/lighter shading), and for the 5 percent of rooms where blanks should be placed (gray/darker shading), these are for the team’s convenience. The selection of rooms for duplicates and blanks should be at random. Remember, there needs to be a minimum of one duplicate and blank per building.]

Stop. For the purposes of planning radon measurement at a school site, this is all that’s needed.

The remaining fields in the log will be filled out when testing of the school actually begins.

[Regarding the remaining fields: “Canister serial #” is the unique identification number found on each test kit; “Date and time opened” and “Date and time closed” refer to the actual moments when kits are placed and activated to begin measuring the radon in the room (and then stopped). This information, when reported to the radon measurement laboratory, helps it adjust its equipment for an accurate analysis of the test kit. **Note:** Staff who will actually conduct testing may be identified when testing actually begins]

If you have questions, please contact the Oregon Radon Awareness Program at

971-673-0440 or radon.program@state.or.us.

www.healthoregon.org/radon

Sample Test Kit Placement Log

Name and physical address of school being tested: South Elementary – ## Street, Salem, OR 97304

Building: Main building **Radon testing contact at school:** Peter Progeny, 503-724-3135

Name of individuals performing testing:

Sammy Sampleton (Logger); Rosie Radon (Placer)

Room description (per floor plan)	Canister serial #	Date opened	Time opened	Date closed	Time closed	Type of test D = detector kit
CR1	100135	11/7/2016	6:00 am	11/10/2016	6:30 am	D
CR2	100137	11/7/2016	6:02 am	11/10/2016	6:37 am	D
CR 3	100139	11/7/2016	6:04 am	11/10/2016	6:40 am	D
CR 4	100140	11/7/2016	6:05 am	11/10/2016	6:44am	D
CR 5	100141	11/7/2016	6:06 am	11/10/2016	6:47 am	D
CR 6	100142	11/7/2016	6:07 am	11/10/2016	6:50 am	D
CR 7	100143	11/7/2016	6:08 am	11/10/2016	6:56 am	D
CR 8	100144	11/7/2016	6:9 am	11/10/2016	6:59 am	D
CR 9	100145	11/7/2016	6:11 am	11/10/2016	7:03 am	D
CR 10	100146	11/7/2016	6:13 am	11/10/2016	7:07 am	D
Same as above	100147	11/7/2016	6:13 am	11/10/2016	7:10 am	Duplicate
CR 11	100148	11/7/2016	6:14 am	11/10/2016	7:15 am	D
Same as above	100149	11/7/2016	6:14 am	11/10/2016	7:23 am	Blank
CR 12	100150	11/7/2016	6:16 am	11/10/2016	7:27 am	D
CR 13	100151	11/7/2016	6:17 am	11/10/2016	7:30 am	D
CR 14	100153	11/7/2016	6:19 am	11/10/2016	7:35 am	D
CR 15	100154	11/7/2016	6:20 am	11/10/2016	7:43 am	D
CR 16	100155	11/7/2016	6:22 am	11/10/2016	7:47 am	D
CR 17	100156	11/7/2016	6:23 am	11/10/2016	7:49 am	D
CR 18	100157	11/7/2016	6:24 am	11/10/2016	8:03 am	D
CR 19	100158	11/7/2016	6:25 am	11/10/2016	8:07 am	D
CR 20	100159	11/7/2016	6:26 am	11/10/2016	8:10 am	D
Same as above	100160	11/7/2016	6:27 am	11/10/2016	8:15 am	Duplicate
CR 21	100161	11/7/2016	6:28 am	11/10/2016	8:23 am	D
CR22	100162	11/7/2016	6:30 am	11/10/2016	8:27 am	D

[Adapted from Burkhart, 2015]

(example log continued)

Room description (per floor plan)	Canister serial #	Date opened	Time opened	Date closed	Time closed	Type of test D = detector kit
CR 23	100163	11/7/2016	6:31 am	11/10/2016	8:27 am	D
CR 24	100164	11/7/2016	6:32 am	11/10/2016	8:30am	D
CR 25	100165	11/7/2016	6:37 am	11/10/2016	8:37 am	D
CR 26	100166	11/7/2016	6:39 am	11/10/2016	8:40 am	D
CR 27	100167	11/7/2016	6:40 am	11/10/2016	8:41 am	D
CR 28	100168	11/7/2016	6:41 am	11/10/2016	8:43 am	D
CR 29	100169	11/7/2016	6:44 am	11/10/2016	8:45 am	D
Same as above	100170	11/7/2016	6:46 am	11/10/2016	8:46 am	Duplicate
CR 30	100171	11/7/2016	6:48 am	11/10/2016	8:47 am	D
same as above	100172	11/7/2016	6:49 am	11/10/2016	8:49 am	Blank
CR 31	100173	11/7/2016	6:49 am	11/10/2016	8:49 am	D
CR 32	100174	11/7/2016	6:49 am	11/10/2016	8:49 am	D
Same as above	100175	11/7/2016	6:51 am	11/10/2016	8:52 am	Duplicate
CR 33	100176	11/7/2016	6:53 am	11/10/2016	8:52 am	D
same as above	100177	11/7/2016	6:54 am	11/10/2016	8:55 am	Blank
CR 34	100178	11/7/2016	6:55 am	11/10/2016	8:57am	D
CR 35	100179	11/7/2016	6:56 am	11/10/2016	8:59 am	D
Computer A	100182	11/7/2016	7:04 am	11/10/2016	9:15 am	D
Computer B	100183	11/7/2016	7:05 am	11/10/2016	9:18 am	D
Gym A	100184	11/7/2016	7:06 am	11/10/2016	9:20 am	D
Gym A	100185	11/7/2016	7:10 am	11/10/2016	9:24 am	D*
Same as above	100186	11/7/2016	7:11 am	11/10/2016	9:30 am	Duplicate
Gym B	100187	11/7/2016	7:14 am	11/10/2016	9:32 am	D
Gym B	100188	11/7/2016	7:15 am	11/10/2016	9:35 am	D
Admin. offices	100189	11/7/2016	7:30 am	11/10/2016	9:37 am	D
Cafeteria	100190	11/7/2016	7:38 am	11/10/2016	9:42am	D

*Gym A is 2,800 square foot space, so has two detector kits. But because duplicates, like other QA kits, are determined by the number of rooms in the building, only one the detector kits is paired with a duplicate.

Test Kit Location Floor Plan Template

Name and physical address of school being tested:

Radon testing contact at school:

School's Floor Plan

Appendix E: Frequently asked questions about radon and schools

1. Does radon cause headaches, eye irritation or sick-building syndrome? *No.*
2. Do children have a greater risk of cancer from radon exposure?
Children usually are more sensitive to environmental pollutants. However, no current data concludes that children are more at risk than adults from radon exposure.
3. Is there a hazard from touching/being near the radon test kit?
No, although kits should be kept away from very young children (toddlers) so they don't eat or chew on them.
4. Do building materials emit radon?
The primary source of radon in a building or home is from the soil underneath it. However, a few building materials such as granite, concrete, gypsum board (sheet rock), bricks and field stone may emit small amounts of radon gas. This is rarely the case because most of these materials are very dense. This means that if there is radon-producing radium in these materials, only a small amount of the radon gas near the surface ever makes it out into the environment.
5. Should testing be delayed if the school is planning major renovations to the building or the HVAC system?
Initial and follow-up tests should be conducted prior to major HVAC or building renovations. Testing can show if a radon mitigation system needs to be installed as a part of renovation. Testing must also be done after renovation.
6. Should upper floors of a school or building be tested? Does this mean that upper floors never have elevated levels?
Upper floors may indeed have elevated levels of radon. However, measurements in ground floor rooms are likely to be a good indicator of radon levels for all floors.
7. In schools with a basement level (below ground level), the first floor is often built at ground level. It is, therefore, in contact with the soil along its outside edge. Should this floor be tested?
This floor appears to have limited contact with the soil. However, the outside rooms may have openings permitting radon entry and should be tested if they are frequently occupied. ORS 332.166-167 requires testing of all frequently occupied rooms in contact with the soil or above a basement or crawlspace.

8. **Nearby homes and schools have reported no elevated levels of radon. Should we still test?**
Yes, radon levels vary with geology, building structure, HVAC systems, etc. The only way to know if radon is present is to test. ORS 332.166-167 states school buildings should be tested every 10 years; current national guidelines (ANSI/AARST, 2014) recommend that school buildings be re-tested every five years (or whenever there is significant renovation or change to a building's HVAC system).
9. **What are the costs of radon testing in schools?**
The cost may depend on the number of rooms to be tested and the type of test kit used. The average cost of radon testing in Oregon schools is approximately \$10 per tested room. This assumes schools purchase short-term test kits in bulk and that school staff perform the testing.
10. **If a room's short-term initial test result is very high (e.g., above 100 pCi/L), should a follow-up measurement be taken?**
Yes, follow-up measurements, even if the initial ones are high, are recommended before making any further decisions.
11. **Should a room be retested if there is evidence the test has been moved or tampered with in any way? Yes.**
12. **How do you place radon test kits in large, open spaces such as cafeterias, gymnasiums or auditoriums?**
Test kits may be hung from the ceiling and or wall using string and masking/duct tape. Be sure to hang them per the "Test Kit Placement Guide" in Appendix A.
13. **How do we test partitioned classrooms?**
Classrooms with movable partitions should be individually tested.
14. **Can you test during unusual weather conditions (heavy rain, snow or wind)?**
Avoid testing during these conditions.
15. **Should we take quality assurance duplicates and blanks during the follow-up tests?**
Yes, per the "Quality assurance" section, starting on [page 29](#). However, there are generally fewer samples taken for follow-up testing.
16. **When two devices (duplicates) are placed in a room during initial testing, which measurement result is taken as the test result?**
Both tests are recorded, but the average is taken as the test result.
17. **What should be done if a device is picked up late or handled incorrectly?**
Handle all test kits in accord with manufacturer's instructions. If there is any discrepancy or problem, the device's serial number should be recorded and noted to the laboratory doing the analysis. Include in the log the actual time device was picked up and a brief description of how the device was mishandled.



This document can be provided upon request in an alternate format for individuals with disabilities or in a language other than English for people with limited English skills. To request this publication in another format or language, contact the Oregon Radon Awareness Program at 971-673-0440, 711 for TTY, or email radon.program@state.or.us.