

SODA SPRINGS JT. SCHOOL DISTRICT #150

**250 East 2nd South
Soda Springs ID 83276**

**Dan Lau- Chairman
Molly Stein, Ed. D. - Superintendent**

**Kim John- Treasurer
Jonathan Balls - Clerk**

Phone (208) 547-3371 Fax (208) 547-4878

03 December 2018

Re: Change Order Options

Below are the change orders and change order options:

CR022 – Do not re-roof existing gable due to lower roof line - (\$3,910)

CR023 – Upgrade to LED Light Poles – 3 options:

Head Only - \$8,000

Pole & Head - \$15,000

Base, Pole, & Head - \$33,000

CR025 – Replace split face block for drinking fountain & FRP Panel - \$1,321

CR026 – Provide paintable Insulation between joists - \$3,593

CR027 – Rework reception area electrical, data, & cabinetry - \$7,677

CR028 – Use MC Cable in bathroom & locker room for lights - (\$1,165)



Change Request #22

Tigert Middle School
HCC Job # 201707

FAX:

Change Request # 022 **Date: 11/14/2018**

To: GPC Architects
18 North Main St. Suite 200
Driggs, ID 83422-

From: Headwaters Construction Company

Attn: Eric Reiser

Signed: Logan Bingham

Phone: (208) 354-8036 **FAX:**

Phone: **FAX:**

Description: Credit for not having to reroof the existing ga

We request your approval to issue a Change Authorization to the appropriate subcontractor(s) for the following:

Smith Roofing	Cost for Work as described in PR 019	(\$3,910.00)
---------------	--------------------------------------	--------------

	Subtotal	(\$3,910.00)
General Liability Insurance	0.000%	\$0.00
Bond	0.00%	\$0.00
Fee	0.00%	\$0.00

The Contract Time will be increased by ZERO Calendar Days

Total Cost of this Request: (\$3,910.00)

Reviewed By _____	Date _____	Recommended By _____	Date _____
ARCHITECT		HCC - PROJECT MANAGER	

PROPOSAL REQUEST

Contractor: Headwater
Construction Co.

Project Name & No.: Tigert Middle School Additions &
Renovations - 1715

Proposal Request No.: 19

Date of Issue: 11.01.18

This is not a change Order, a construction change directive or a direction to proceed with the work described in the proposed modifications.

Please submit an itemized proposal for changes in the Contract Sum and Contract Time for proposed modifications to the Contract Documents described herein. Within Ten (10) days, the Contractor must submit this proposal or notify the Architect, in writing, of the date on which proposal submission is anticipated.

Description: (Written description of the work)

- 1.1 Please provide a cost proposal to provide the changes outlined below. This request does not imply acceptance of the proposal.

Provide the following changes to the Classroom Addition roof on Sheet A4.1 & A4.2 as follows:

1. Revise "This existing gable to be re-shingled with construction of classroom wing roof" to "No work will be required to this existing gable with the construction of the classroom wing roof".
2. Add Detail Bubble 8/A4.2 at edge of existing roof and new roof.
3. Add Detail 8/A4.2 Roof Step Detail.

Attachments: (List of attached documents that support the description)

Detail 8/A4.2 Roof Step Detail

**Smith Roofing
and Siding, LLC.**

253 N 4000 E
Rigby, ID 83442
(208) 745-7588

ID Contractor #: RCE-1916
Public Works: PWC-C-11160-AA-4



Proposal

11/13/2018

Headwaters Construction, Co.
639 W 9500 S
Suite 1
Victor, ID 83455

Re: Tigert Middle School

PR#19

14 sq shingles @ \$115.00	\$1,610.00
15 sq underlayment @ \$40.00	\$ 600.00
Remove existing shingles	\$ 980.00
Install new shingles	\$ 420.00
Out of town	\$ 300.00
	<u> </u>
	<u> </u>
	\$3,910.00 credit back

Thank You

Jerry Hampton
Smith Roofing & Siding, LLC

PR. NO.

19

11/01/2018

B

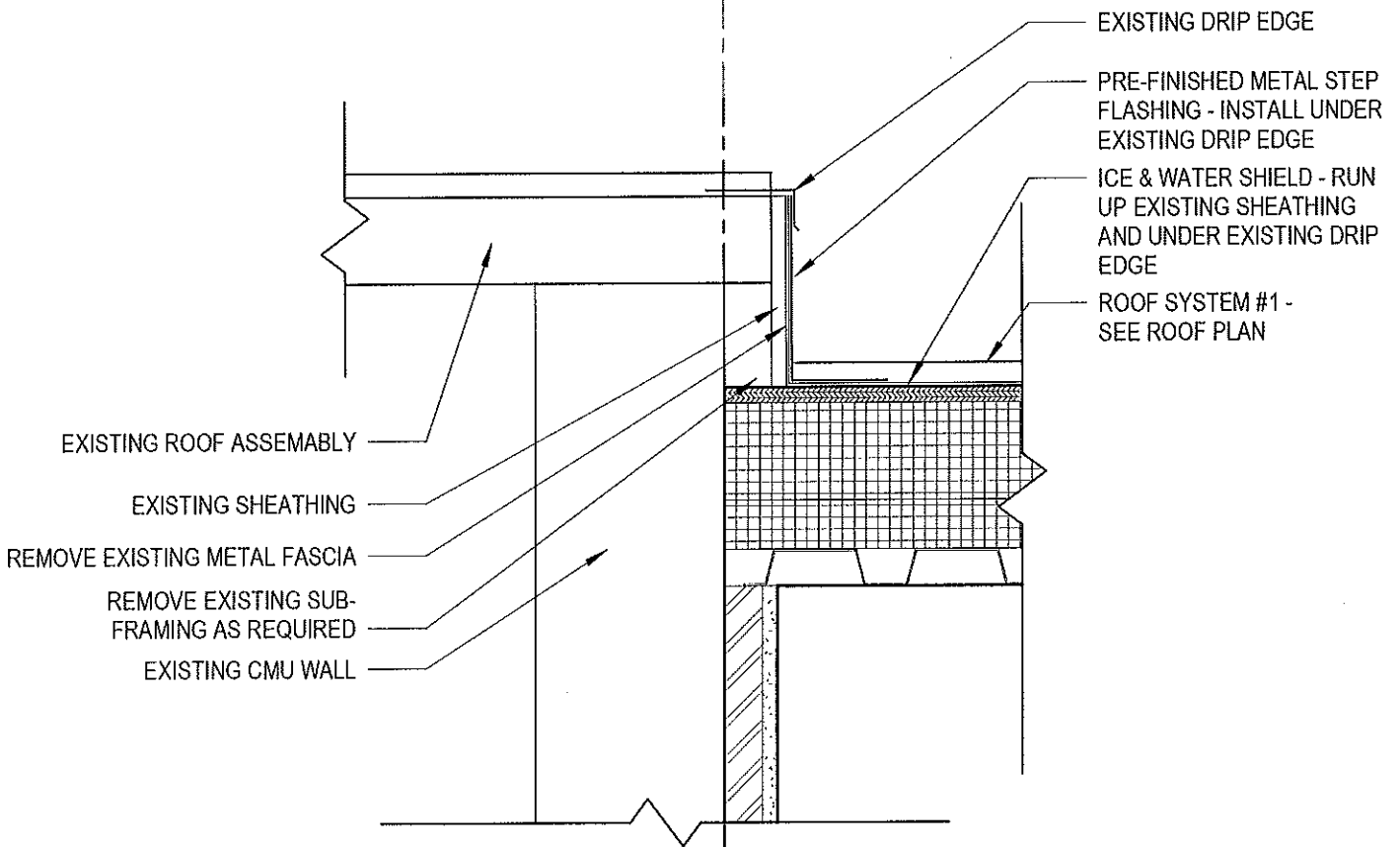

8
A4.2

ROOF STEP DETAIL

1 1/2" = 1'-0"

PROPOSAL REQUEST

Contractor: Headwater
Construction Co.

Project Name & No.: Tigert Middle School Additions &
Renovations - 1715

Proposal Request No.: 20
Date of Issue: 11.01.18

This is not a change Order, a construction change directive or a direction to proceed with the work described in the proposed modifications.

Please submit an itemized proposal for changes in the Contract Sum and Contract Time for proposed modifications to the Contract Documents described herein. Within Ten (10) days, the Contractor must submit this proposal or notify the Architect, in writing, of the date on which proposal submission is anticipated.

Description: (Written description of the work)

1.1 Please provide a cost proposal to provide the changes outlined below. This request does not imply acceptance of the proposal.

Provide three options to replace the six (6) existing light poles with the same light pole that is speced in the drawings as follows:

1. Remove and replace the head unit only. $\pm 8,000$
2. Cut of the existing pole and replace with new pole and head. Anchor into the existing light pole base and utilize the existing wiring. $\pm 15,000$
3. Remove the existing base, pole, head and wiring and replace with all new. $\pm 33,000$

Attachments: (List of attached documents that support the description)

None.

ARCO ELECTRIC

Project #: 218



PO Box 50429
 Idaho Falls, Idaho 83405
 (208) 522-2185
 Fax 529-3423
 doug@arcoelectric-idaho.com

Project Name: Tigert
Change Event No.:
Description: PR20 option 1 replace heads only reuse poles and conductors.

Submitted To: Headwaters CC Inc.

Arco Electric is not responsible for the condition of the existing poles and will not warrant the existing poles.

Cost Breakdown

Quoted Materials:		\$3,316.89
Miscellaneous Materials:		\$374.73
Sales/Use Tax:	6%	\$221.50
Subtotal:		\$3,913.12

Total Hours:	39.0		
	<u>Hours</u>	<u>Rate</u>	
Project Manager	0.0	\$85.00	\$0.00
Project Foreman	0.0	\$80.00	\$0.00
Journeyman Electrician	39.0	\$78.00	\$3,042.00
Overtime	0.0	\$117.00	\$0.00
Subtotal:			\$3,042.00

Overhead	@	10%	\$391.31
Profit	@	0%	\$0.00
Subtotal:			\$391.31

	<u>Amount</u>	<u>Mark-Up</u>	<u>Extended Amount</u>
Subcontracts	\$0.00	10%	\$0.00
Subsistence	\$0.00	10%	\$0.00
Housing	\$0.00	10%	\$0.00
Truck & Tool (within 60 days of substantial)	\$0.00	10%	\$0.00
Subtotal:			\$0.00

Permits: (State Over \$10,000)		\$0.00
Bonds & Insurance	@ 3%	\$0.00

Grand Total: \$7,346

+ \$8,000.

Notes: See accompanying breakdown.
 Pricing inclusive of items shown.
 Prices firm for 10 days.
 Contract extension of 0 days.
 Material delivery time of 10 days.

Prepared By: Doug Gray

Date: 11/20/2018

Approved By: _____
 Headwaters CC Inc.

Date: _____

Please fax a signed copy of all approved changes to our office at 529-3423. Work will not begin without a signed approval.

ARCO ELECTRIC

Project #: 218



PO Box 50429
 Idaho Falls, Idaho 83405
 (208) 522-2185
 Fax 529-3423
doug@arcoelectric-idaho.com

Project Name: Tigert
Change Event No.
Description: PR20 option 2 cut poles off at base and reuse conduit, conductor and base.

Submitted To: Headwaters CC Inc.

Arco electric is not responsible for the condition or integrity of the existing pole bases, we do not provide warranty of these bases.

Cost Breakdown

Quoted Materials:		\$6,018.69
Miscellaneous Materials:		\$915.94
Sales/Use Tax:	6%	\$416.08
Subtotal:		\$7,350.70

Total Hours: 73.0

	Hours	Rate	
Project Manager	0.0	\$85.00	\$0.00
Project Foreman	0.0	\$80.00	\$0.00
Journeyman Electrician	73.0	\$78.00	\$5,694.00
Overtime	0.0	\$117.00	\$0.00
Subtotal:			\$5,694.00

Overhead	@	10%	\$735.07
Profit	@	0%	\$0.00
Subtotal:			\$735.07

	Amount	Mark-Up	Extended Amount
Subcontracts	\$0.00	10%	\$0.00
Subsistence	\$0.00	10%	\$0.00
Housing	\$0.00	10%	\$0.00
Truck & Tool (within 60 days of substantial)	\$0.00	10%	\$0.00
Subtotal:			\$0.00

Permits: (State Over \$10,000)		\$0.00
Bonds & Insurance	@ 3%	\$0.00

Grand Total: \$13,780

+15,000
 = 15,000

Notes: See accompanying breakdown.
 Pricing inclusive of items shown.
 Prices firm for 10 days.
 Contract extension of 0 days.
 Material delivery time of 10 days.

Prepared By: Doug Gray

Date: 11/20/2018

Approved By: _____
 Headwaters CC Inc.

Date: _____

Please fax a signed copy of all approved changes to our office at 529-3423. Work will not begin without a signed approval.

ARCO ELECTRIC

Project #: 218



PO Box 50429
Idaho Falls, Idaho 83405
(208) 522-2185
Fax 529-3423
doug@arcoelectric-idaho.com

Project Name: Tigert
Change Event No.
Description: PR20 option 3, replace conduit, conductors, base, poles and heads.

Submitted To: Headwaters CC Inc.

This pricing does not include any restoration of any landscaping, concrete or asphalt.

Cost Breakdown

Quoted Materials:		\$6,018.69
Miscellaneous Materials:		\$8,919.20
Sales/Use Tax:	8%	\$996.27
Subtotal:		\$15,834.16

Total Hours: 164.0

	Hours	Rate	
Project Manager	0.0	\$85.00	\$0.00
Project Foreman	0.0	\$80.00	\$0.00
Journeyman Electrician	164.0	\$78.00	\$12,792.00
Overtime	0.0	\$117.00	\$0.00
Subtotal:			\$12,792.00

Overhead	@	10%	\$1,583.42
Profit	@	0%	\$0.00
Subtotal:			\$1,583.42

	Amount	Mark-Up	Extended Amount
Subcontracts	\$0.00	10%	\$0.00
Subsistence	\$0.00	10%	\$0.00
Housing	\$0.00	10%	\$0.00
Truck & Tool (within 60 days of substantial)	\$0.00	10%	\$0.00
Subtotal:			\$0.00

Permits: (State Over \$10,000)		\$0.00
Bonds & Insurance	@ 3%	\$0.00

Grand Total: **\$30,210**

Total 33,000

Notes: See accompanying breakdown.
 Pricing inclusive of items shown.
 Prices firm for 10 days.
 Contract extension of 0 days.
 Material delivery time of 10 days.

Prepared By: Doug Gray

Date: 11/20/2018

Approved By: _____
 Headwaters CC Inc.

Date: _____

Please fax a signed copy of all approved changes to our office at 529-3423. Work will not begin without a signed approval.



Change Request #25

Tigert Middle School
HCC Job # 201707

FAX:

Change Request # 025 **Date: 11/26/2018**

To: GPC Architects
18 North Main St. Suite 200
Driggs, ID 83422-

From: Headwaters Construction Company

Attn: Eric Reiser

Signed: Logan Bingham

Phone: (208) 354-8036 **FAX:**

Phone: **FAX:**

Description: Reface CMU per PR 022

We request your approval to issue a Change Authorization to the appropriate subcontractor(s) for the following:

JL England Masonry	Cost to reface split face block per PR 022	\$1,250.00
--------------------	--	------------

*For existing exterior gym wall - East -
to put FRP (Panel) in utility mechanical
room mop sink and drinking fountain
in gym.*

Subtotal	\$1,250.00
General Liability Insurance 0.380%	\$5.00
Bond 0.73%	\$9.00
Fee 4.50%	\$57.00

The Contract Time will be increased by ZERO Calendar Days

Total Cost of this Request: \$1,321.00

Reviewed By 
ARCHITECT

Date 12-3-18

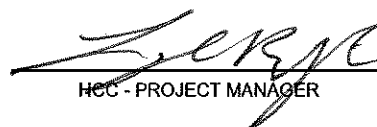
Recommended By 
HCC - PROJECT MANAGER

Date 12-3-18

John Eskelson

From: John England <johneng@cableone.net>
Sent: Monday, November 26, 2018 11:25 AM
To: John Eskelson
Subject: PR#22

PR#22

32 hours at\$35.00=\$1120.00

32 block @\$2.50 =\$80.00

1 batch mortar@\$50.00

Total =1250.00

Thanks, John

PROPOSAL REQUEST

Contractor: Headwater
Construction Co.

Project Name & No.: Tigert Middle School Additions &
Renovations - 1715

Proposal Request No.: 25

Date of Issue: 11.27.18

This is not a change Order, a construction change directive or a direction to proceed with the work described in the proposed modifications.

Please submit an itemized proposal for changes in the Contract Sum and Contract Time for proposed modifications to the Contract Documents described herein. Within Ten (10) days, the Contractor must submit this proposal or notify the Architect, in writing, of the date on which proposal submission is anticipated.

Description: (Written description of the work)

1.1 Please provide a cost proposal to provide the changes outlined below. This request does not imply acceptance of the proposal.

Electrical contractor shall provide a credit to the owner for use of MC cable in lieu of conduit and wire.

Attachments: (List of attached documents that support the description)

None.



Change Request #26

Tigert Middle School
HCC Job # 201707

FAX:

Change Request # 026 **Date: 11/15/2018**

To: GPC Architects
18 North Main St. Suite 200
Driggs, ID 83422-

Attn: Eric Reiser
Phone: (208) 354-8036 **FAX:**

From: Headwaters Construction Company

Signed: Logan Bingham
Phone: **FAX:**

Description: Paintable Insulation between the Joists per P

We request your approval to issue a Change Authorization to the appropriate subcontractor(s) for the following:

BDI Insulation of Idaho Falls	Provide intumescent paint for urethane per direction OAC meeting	\$600.00
Aspen Painting	Cost to apply intumescent paint and repaint joists and ceiling at erat	\$600.00
BDI Insulation of Idaho Falls	Provide Paintable insulation between the joists as per PR 024	\$2,200.00

	Subtotal	\$3,400.00
General Liability Insurance	0.380%	\$13.00
Bond	0.73%	\$25.00
Fee	4.50%	\$155.00

The Contract Time will be increased by ZERO Calendar Days

Total Cost of this Request: \$3,593.00

Reviewed By _____ Date _____ Recommended By _____ Date _____
ARCHITECT HCC - PROJECT MANAGER

From: Stierle, Rogue <rstierle@bdiinsulation.com>
Sent: Thursday, November 29, 2018 10:02 AM
To: John Eskelson
Cc: Stierle, Rogue
Subject: Tigert Change orders & Info

Follow Up Flag: Follow up
Flag Status: Flagged

John

I need 2 change orders for Tigert

1. \$2200 for foam and Batts at eve ends
- ~~2. \$1600 for 6" of foam on ceiling Mike had my guys do while they were there~~
Paint is \$300 Per bucket you will need 2 for the foam at eve ends and the 6" on ceiling

thanks

Rogue Stierle
Branch Manager



BDI insulation of Idaho Falls, INC (897)
1460 Commerce Way
Building A
Idaho Falls, ID 83401
Direct Line (208)351-9517
Fax (866)462-0156
rstierle@bdiinsulation.com

Per conversation with Leo at Aspen Painting they will have one day for paint and touch-up for the intumescent paint for a total of \$600.00

JE HWCC



Change Request #27

Tigert Middle School
HCC Job # 201707

FAX:

Change Request # 027 **Date: 11/26/2018**

To: GPC Architects
18 North Main St. Suite 200
Driggs, ID 83422-

From: Headwaters Construction Company

Attn: Eric Reiser

Signed: Logan Bingham

Phone: (208) 354-8036 **FAX:**

Phone: **FAX:**

Description: Rework of Cabinetry in Reception per PR 014r

We request your approval to issue a Change Authorization to the appropriate subcontractor(s) for the following:

Arco Electric Idaho, Inc	<i>Data and</i> Cost for electrical and low voltage per PR 014r1	\$3,485.00
Interwest Wood Design, Inc	Cost for case work and countertops per PR 014r1	\$3,780.00

Subtotal	\$7,265.00
General Liability Insurance 0.380%	\$28.00
Bond 0.73%	\$53.00
Fee 4.50%	\$331.00

The Contract Time will be increased by ZERO Calendar Days

Total Cost of this Request: \$7,677.00

Reviewed By *[Signature]*
ARCHITECT

Date 12/13/18

Recommended By *[Signature]* Date 12-3-18
HCC PROJECT MANAGER

PROPOSAL REQUEST

Contractor: Headwater
Construction Co.

Project Name & No.: Tigert Middle School Additions &
Renovations - 1715

Proposal Request No.: 14R1

Date of Issue: 08.16.18

This is not a change Order, a construction change directive or a direction to proceed with the work described in the proposed modifications.

Please submit an itemized proposal for changes in the Contract Sum and Contract Time for proposed modifications to the Contract Documents described herein. Within Ten (10) days, the Contractor must submit this proposal or notify the Architect, in writing, of the date on which proposal submission is anticipated.

Description: (Written description of the work)

1.1 Please provide a cost proposal to provide the changes outlined below. This request does not imply acceptance of the proposal.

Provide power/data to workstation in front of diagonal wall – see attached Workstation Picture A.

Provide data at workstation under window with new talk-through speaker.

Provide data under new sliding window.

Remove countertop and one set of 15" drawers in front of new sliding window – see attached Countertop and Drawers Picture B.

Remove and replace existing main countertop and upper countertop.

Add matching p-lam to end panel and face panel of existing island cabinet that was cut back.

Attachments: (List of attached documents that support the description)

Workstation Picture A

Countertop and Drawers Picture B



01. Workstation Picture A.jpeg



02. Countertop and Drawers Picture B.jpeg

John Eskelson

From: Kirk Newson <iwd3850@gmail.com>
Sent: Tuesday, October 23, 2018 12:03 PM
To: John Eskelson
Subject: RE: Tigert Middle School - PR 014r1

John, please figure \$3780.00 for the casework on this pr

From: John Eskelson <jeskelson@headwaterscc.com>
Sent: Tuesday, October 23, 2018 8:01 AM
To: Kirk Newson <iwd3850@gmail.com>
Subject: FW: Tigert Middle School - PR 014r1

Kirk,
Attached is the PR we discussed.

Thanks,

John Eskelson

Headwaters Construction Company

C: (208) 313-7338; E: JEskelson@HeadwatersCC.com

www.HeadwatersCC.com

From: John Eskelson
Sent: Tuesday, August 21, 2018 10:31 AM
To: apluscontractors@qwestoffice.net; Jason Ford <JasonF@ABSDoors.com>; arco-bill@qwestoffice.net; aspenspainting1@gmail.com; bybeet@gmail.com; rstierle@bdiinsulation.com; Casey Sittniewski <Casey.Sittniewski@consurco.com>; Tim Ling <tim.ling@consurco.com>; Crystal Dial <crystal@croftbeckfloors.com>; 'Matt Dumar' <matt@dcrld.com>; Bret Hatch <bret@hatchcoidaho.com>; Corie Oberg <corie.oberg@ieisteel.com>; Jade Snarr <jade.snarr@ieisteel.com>; Kirk Newson <iwd3850@gmail.com>; johneng@cableone.net; 'Mason Lewis' <mason@lcorp.com>; searls@mesatileandstone.com; Bobby Hood <bhood@mesatileandstone.com>; Audra Ebben <audra@mesatileandstone.com>; Justin Hill <justin@mwmddirect.com>; brianh@norconindustries.net; Mark Hannasch <MarkH@norconindustries.net>; Stewart Hayes <StewartH@norconindustries.net>; Trent Bice <trent@phoenixfp.com>; Teri Cruickshank <teri@phoenixfp.com>; Dan Hoopes <dhoopes@precisionglass.net>; Aaron Wilcox <aaronbwilcox@gmail.com>; mohd@cableone.net; Tyler Oliver <tyler@sbicontractinginc.com>; Jerry <jerry@smithroofingpros.com>; 'pablo d soriano' <pablo@sorianofloors.com>; Jayson Calderwood <jaysontcn@silverstar.com>; United Concrete Polishing <unitedconcretepolishing@gmail.com>
Cc: Michael Adams <madams@headwaterscc.com>; Logan Bingham <lbingham@headwaterscc.com>
Subject: RE: Tigert Middle School - PR 014r1

All,

See attached PR 014. Please review for any changes to your scope. If there are any cost or schedule impacts resulting from this document you must notify us within 5 business days. Please remember that it is your responsibility to ensure that the information contained in these documents is communicated to your field personnel. You are also responsible for maintaining your own current and updated set of documents. Please let me know if you have any questions or concerns regarding these changes.

Thanks,

ARGO ELECTRIC

Project #: 218



PO Box 50429
 Idaho Falls, Idaho 83405
 (208) 522-2185
 Fax 529-3423
doug@arcoelectric-idaho.com

Project Name: TIGERT
Change Event No. PR14R1
Description: Add power and data drops per PR14R1.

Submitted To Headwaters CC Inc.

Cost Breakdown

Quoted Materials:		\$0.00
Miscellaneous Materials:		\$386.17
Sales/Use Tax:	6%	\$23.17
Subtotal:		\$409.34

Total Hours: 13.0

	Hours	Rate	
Project Manager	0.0	\$85.00	\$0.00
Project Foreman	0.0	\$80.00	\$0.00
Journeyman Electrician	13.0	\$78.00	\$1,014.00
Overtime	0.0	\$117.00	\$0.00
Subtotal:			\$1,014.00

Overhead	@	10%	\$40.93
Profit	@	0%	\$0.00
Subtotal:			\$40.93

	Amount	Mark-Up	Extended Amount
Subcontracts Systech	\$1,837.00	10%	\$2,020.70
Subsistence	\$0.00	10%	\$0.00
Housing	\$0.00	10%	\$0.00
Truck & Tool (within 60 days of substantial)	\$0.00	10%	\$0.00
Subtotal:			\$2,020.70

Permits: (State Over \$10,000)		\$0.00
Bonds & Insurance	@ 3%	\$0.00

Grand Total: **\$3,485**

Notes: See accompanying breakdown.
 Pricing inclusive of items shown.
 Prices firm for 10 days.
 Contract extension of 0 days.
 Material delivery time of 10 days.

Prepared By: Doug Gray

Date: 9/25/2018

Approved By: _____
 Headwaters CC Inc.

Date: _____

Please fax a signed copy of all approved changes to our office at 529-3423. Work will not begin without a signed approval.



Change Request #28

Tigert Middle School
HCC Job # 201707

FAX:

Change Request # 028 **Date: 11/30/2018**

To: GPC Architects
18 North Main St. Suite 200
Driggs, ID 83422-

From: Headwaters Construction Company

Attn: Eric Reiser

Signed: Logan Bingham

Phone: (208) 354-8036 **FAX:**

Phone: **FAX:**

Description: Credit to use MC Cable in Lieu of Conduit and

We request your approval to issue a Change Authorization to the appropriate subcontractor(s) for the following:

Arco Electric Idaho, Inc	Credit to use MC cable per PR 025	(\$1,165.00)
--------------------------	-----------------------------------	--------------

	Subtotal	(\$1,165.00)
General Liability Insurance	0.000 %	\$0.00
Bond	0.00 %	\$0.00
Fee	0.00 %	\$0.00

The Contract Time will be increased by ZERO Calendar Days

Total Cost of this Request: (\$1,165.00)

Reviewed By 
ARCHITECT

Date 12/13/18

Recommended By 
HCC - PROJECT MANAGER

Date 12-3-18

ARCO ELECTRIC

Project #: 1



PO Box 50429
Idaho Falls, Idaho 83405
(208) 522-2185
Fax 529-3423
doug@arcoelectric-idaho.com

Project Name: TIGERT
Change Event No.:
Description: PR 25 MC CABLE CREDIT

Submitted To HEADWATERS CC INC.

Cost Breakdown

Miscellaneous Materials:	CONDUIT		-\$977.23
Miscellaneous Materials:	MC CABLE		\$737.09
<u>Sales/Use Tax:</u>		6%	<u>-\$14.41</u>
	Subtotal:		-\$254.55

Total Hours: -12.0

	<u>Hours</u>	<u>Rate</u>	
Project Manager	0.0	\$85.00	\$0.00
Project Foreman	0.0	\$80.00	\$0.00
Journeyman Electrician	-12.0	\$78.00	-\$936.00
<u>Overtime</u>	<u>0.0</u>	<u>\$117.00</u>	<u>\$0.00</u>
	Subtotal:		-\$936.00

Overhead	@	10%	\$25.45
<u>Profit</u>	<u>@</u>	<u>0%</u>	<u>\$0.00</u>
	Subtotal:		\$25.45

	<u>Amount</u>	<u>Mark-Up</u>	<u>Extended Amount</u>
Subcontracts	\$0.00	15%	\$0.00
Subsistence	\$0.00	15%	\$0.00
Housing	\$0.00	15%	\$0.00
<u>Truck & Tool (within 60 days of substantial)</u>	<u>-\$42.00</u>	<u>15%</u>	<u>\$0.00</u>
	Subtotal:		\$0.00

Permits: (State Over \$10,000)		\$0.00
Bonds & Insurance	@ 3%	\$0.00

Grand Total: **-\$1,165**

Notes: See accompanying breakdown.
 Pricing inclusive of items shown.
 Prices firm for 10 days.
 Contract extension of 0 days.
 Material delivery time of 10 days.

Prepared By: DOUG GRAY

Date: 11/30/2018

Approved By: _____

Date: _____

HEADWATERS CC INC.

Please fax a signed copy of all approved changes to our office at 529-3423. Work will not begin without a signed approval.



Project #: 1

PO Box 50429
 Idaho Falls, Idaho 83405
 (208) 522-2185
 Fax 529-3423
 doug@arcoelectric-idaho.com

Project Name: TIGERT MIDDLE SCHOOL
 CE Summary: PR25 CONDUIT

#	Category	Description	Size	Qty	UOM	Adj. Unit	Ext
PR25 CONDUIT							
Category 003: CONDUIT							
1	CONDUIT	EMT	1/2"	800.00	FEET	0.44	350.52
Subtotals for Category 003: CONDUIT							350.52
Category 005: FITTINGS							
2	FITTINGS	EMT COUP SSS	1/2"	80.00	EACH	0.33	26.78
Subtotals for Category 005: FITTINGS							26.78
Category 007: SUPPORTS & HARDWARE							
3	SUPPORTS & HARDWARE	EMT 1 HOLE STRAP	1/2"	100.00	EACH	0.29	29.06
4	SUPPORTS & HARDWARE	TEK SCREWS		100.00	EACH	0.02	2.48
Subtotals for Category 007: SUPPORTS & HARDWARE							31.54
Category 011: WIRE							
6	WIRE	THHN SOL CU	#12	2100.00	FEET	0.20	426.29
6	WIRE	THHN CU GREEN	#12	840.00	FEET	0.17	142.10
Subtotals for Category 011: WIRE							568.39
Grand Totals for PR25 CONDUIT							977.23