

No. _____



UNITED INDEPENDENT SCHOOL DISTRICT AGENDA ACTION ITEM

TOPIC Approval of Requests from Juan A. Molina for Use of Board of Trustees Discretionary Funds for United South High School for \$11,783.24 and Perez Elementary School for \$7,686.02

SUBMITTED BY: Juan Antonio Molina, Jr. **OF:** Board Member

APPROVED FOR TRANSMITTAL TO SCHOOL BOARD: _____

DATE ASSIGNED FOR BOARD CONSIDERATION: October 21, 2009

RECOMMENDATION:

It is recommended that the United ISD Board of Trustees approve a requests from Juan A. Molina for Use of Board of Trustees Discretionary Funds for United South High School for \$11,783.24 and Perez Elementary School for \$7,686.02.

RATIONALE:

BUDGETARY INFORMATION

BOARD POLICY REFERENCE AND COMPLIANCE:



Exhibit A

**United Independent School District
Board of Trustees Discretionary Funds Request Form
Fiscal Year 2009-2010**

Requesting Campus: United South High School

Campus Principal: David Canales

Board Member: Juan A. Molina, Jr.

Board Member: Ricardo Rodriguez

Description of Request:

USHS UIL ACADEMICS - Travel expenses for Academic Meets in San Antonio, Tx. on 12/5/09, Del Rio, Tx. on 1/23/10, and Austin, Tx. on 2/27/10. All Literary and Speaking Events will attend. Expenses include: Transportation, meals, lodging and entry fees. (attachment: travel expenses and list of events participating)

USHS - BUSINESS & TECHNOLOGY MAGNET - Purchase of 25 Navy Professional Blazers with embroidered Academy Logo for the Administrative Procedures Internship Course. Student interns will work in connection with the City of Laredo. (attachment: EmbroideMe quote)

Estimated Cost of Request: USHS UIL - \$10,287.00; USHS Magnet - \$1,496.24

Principal Signature: David Canales Date 10/6/09

Board Member Approval: Yes No

Board Member Signature: [Signature] Date 10/8/09

Board Member Signature: _____ Date _____

Superintendent Signature: _____ Date _____

Board Approval: Yes No Date Approved: _____

Please return the completed form to the Superintendent's Office for final processing.

ESTIMATE
2009-2010 UIL MEET EXPENSES

| DATE | DESTINATION | TRANSPORTATION | VAN RENTAL | MEALS | LODGING | ENTRY FEE | TRIP COST |
|-----------|-------------|----------------|------------|-------------|---------|-------------|--------------|
| 12/5/2009 | San Antonio | \$ 1,545.00 | \$ 49.00 | \$ 900.00 | | \$ 735.00 | \$ 3,229.00 |
| 1/23/2010 | Del Rio | \$ 1,680.00 | \$ 49.00 | \$ 900.00 | | \$ 735.00 | \$ 3,364.00 |
| 2/27/2010 | Austin | \$ 2,010.00 | \$ 49.00 | \$ 900.00 | | \$ 735.00 | \$ 3,694.00 |
| | | | | | | | |
| | | | | | | | |
| | | | | | | | |
| | | | | | | | |
| | | | | | | | |
| | | | | | | | |
| TOTALS | | \$ 5,235.00 | \$ 147.00 | \$ 2,700.00 | \$ - | \$ 2,205.00 | \$ 10,287.00 |



David Canales
Principal

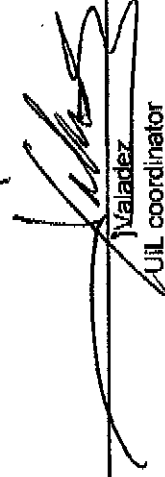

Valadez
UIL coordinator

2009-2010

UIL-Coaches

| | Event | Coach |
|----|--------------------|--------------------------|
| 1 | Accounting | Ms. Raquel Garcia |
| 2 | Calculator | Mr. Angel Aviles |
| 3 | Computer Science | Mr. Michael Soto |
| 4 | Current Events | Christina de Anda |
| 5 | Debate | jValadez*** |
| 6 | Extemporaneous | Ms. Lucero Mendez |
| 7 | Journalism | Ms. Linda Lee Ramon |
| 8 | Computer Apps. | Anita Costilla |
| 9 | Literary Criticism | Mrs. Argelia Ortiz |
| 10 | Mathematics | Ms. Sara Montemayor |
| 11 | Number Sense | Mrs. Angela Erazo-Molina |
| 12 | One-Act Play | Ms. Sarah Dickey |
| 13 | Prose & Poetry | Ms. Amanda Cruz |
| 14 | Ready Writing | Mrs. Lourdes Gonzalez |
| 15 | Science | Mr. JJ Hernandez |
| 16 | Science | Mr. Andres M. Lazcano |
| 17 | Spelling & Voc. | Mr. Rene Carrillo** |
| 18 | Social Studies | Mrs. Rosa C. Salazar |
| 19 | UIL-Asst. Coord | Ms. Rebecca Contreras |
| 20 | UIL-Coordinator | Mr. jValadez*** |
| 21 | UIL-Admintrator | Mrs. P. Munoz |



Quotation

E 7300

EmbroidMe / Get Noticed Laredo

Phone: 956-723-8535 Fax: 956-723-8536

E-Mail: deborah@getnoticedlaredo.com

Website: www.embroidme-laredo.com

Laredo, Texas

Date: 3/20/2009

Billing Information

United South High School

Phone: 473-5441

Shipping Information

Contact: Angie Sanchez

Cell Number: 763-6444

Fax:

E-Mail: aasanchez@sbcglobal.net

Ship Method: Pick Up

Sales Rep: House Account

| Style | Description | Color / Location | Size | Qty | Unit Price | Line Total |
|-------|--------------------------------|------------------|------|-----|------------|------------|
| 3500 | Men's Professional Blazer | 17 DARK NAVY | 36R | 12 | 59.85 | 718.20 |
| 6500 | Women's Professional Blazer | 17 DARK NAVY | 10R | 13 | 59.85 | 778.05 |
| | Embroidery | | | 25 | | |
| | Logo Setup (\$49 value waived) | | | 1 | | |

Notes

Womens 10R-20T

Men's - 36R - 46T

Larger sizes - additional cost

We stand ready to produce your order

| | |
|--------------------|---------|
| Total | 1496.25 |
| Tax Amount | 0.00 |
| Net Total | 1496.25 |
| Deposit Req | 748.13 |

All orders subject to our standard terms and conditions.

Date Accepted _____

Print Name: _____

Signature: _____



Exhibit A

**United Independent School District
Board of Trustees Discretionary Funds Request Form
Fiscal Year 2009-2010**

Requesting Campus: DR. S. PEREZ ELEMENTARY

Campus Principal: MARIA DE LOURDES VILORIA

Board Member: JUAN MOLINA

Board Member: Mr. Juan Molina

Description of Request: Ice maker needed due to
the previous one not working. Trophy cases
needed for trophy display. Janitorial
supply needed for custodians.

Estimated Cost of Request 7,686.02

Principal Signature: Maria de Lourdes Viloria Date 10/8/09

Board Member Approval: Yes No

Board Member Signature: Juan Molina Date 10/8/09

Board Member Signature: _____ Date _____

Superintendent Signature: _____ Date _____

Board Approval: Yes No Date Approved: _____

Please return the completed form to the Superintendent's Office for final processing.



UNITED INDEPENDENT SCHOOL DISTRICT

Purchase Requisition

Discretionary Funds

Page 1 to 1

Vendor Name and Address

GULF COAST

| FUND/YR | FUNC. | ORG. | PROGRAM CODE | LOCAL OPTION | PROJECT NUMBER | SUB OBJECT | OBJECT | AMOUNT |
|---------|-------|------|-----------------|-----------------|-------------------|---------------|--------|--------|
| | | | | | | | | |
| | | | | | | | | |
| | | | | | | | | |

Phone No: _____

Campus: DR. S. PEREZ ELEM. Rm NO: OFFICE

Date: 9-16-09

| QTY | ITEM # | DESCRIPTION | UNITED PRICE WITH DISCOUNT | EXTENSION |
|-----|--------|---------------------------|----------------------------------|-----------|
| 1 | 20TS | Advance 2-speed buffer | \$ 963.36 | |
| 1 | SCV | Super Coach Vac w/Attach. | \$ 359.84 | |
| | | | | |
| | | | | |
| | | | | |
| | | | | |
| | | | | |
| | | | | |
| | | | | |
| | | | | |
| | | | | |
| | | | | |
| | | | | |
| | | | | |
| | | | | |
| | | | | |
| | | | | |
| | | | | |
| | | | | |
| | | | | |
| | | | | |
| | | | | |
| | | | | |
| | | | | |

DISPOSITION: Pick-up Mail Check FAX # _____ PAGE TOTAL _____

REMARK: _____ GRAND TOTAL 1,323.20

MARIA DE LOURDES VIDORIA
ORIGINATOR (PRINT)

ADMINISTRATOR SIGNATURE

9-16-09
DATE
10/8/09
DATE

BUDGET COORDINATOR DATE

OTHER DATE

ORDER # 710-5699
 BILL TO: MR MARTINEZ
 GULF COAST PAPER COMPANY, INC.
 ORDER ENTRY FORM

SHIP TO: UNITED LSA
PEREZ ELEM.

CUSTOMER#

COMMENT TO PRINT:

PO# _____ VIA _____ ORDER DATE: _____ SCHED SHIP: _____
 SALESMAN# _____

| QUANTITY | U/M | ITEM NUMBER | DESCRIPTION | TAX | S/PRICE * |
|----------|-----|-------------|---------------------------|-----|-----------|
| 1. | EA | 20TS | ADVANCE 2-SPEED BUFFER | | 963.36 |
| 2. | | | | | |
| 3. | | | | | |
| 4. | EA | SCV | SUPER COACH VAC w/ATTACH. | | 359.84 |
| 5. | | | | | |
| 6. | | | | | |
| 7. | | | | | |
| 8. | | | | | |
| 9. | | | | | |
| 10. | | | | | |
| 11. | | | | | |
| 12. | | | | | |
| 13. | | | | | |
| 14. | | | | | |
| 15. | | | | | |
| 16. | | | | | |
| 17. | | | | | |
| 18. | | | | | |

* PUT A PRICE HERE ONLY IF IT IS TO BE DIFFERENT THAN STATED PRICES.

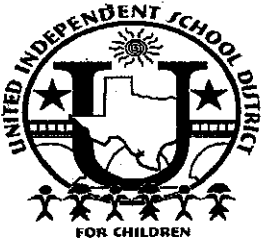

UNITED INDEPENDENT SCHOOL DISTRICT Purchase Requisition

Page 1 to 1

Vendor Name and Address

School Specialty
P.O. Box 1579

Appleton, WI 54912-1579

Phone No: 1-888-388-3224

Campus: _____ Rm NO: _____

Date: _____

| FUND/YR FUNC. | ORG. | PROGRAM LOCAL PROJECT CODE | OPTION NUMBER | OBJECT | SUB OBJECT | OBJECT AMOUNT |
|---------------|------|----------------------------|---------------|--------|------------|---------------|
| | | | | | | |
| | | | | | | |
| | | | | | | |

BUDGET CODE

ACCOUNT CODE

| QTY | ITEM # | DESCRIPTION | UNITED PRICE WITH DISCOUNT | EXTENSION |
|-----|------------|--|----------------------------|-----------|
| 2 | 631980-030 | Varsity Oak Floor Case - Trophy 48" x 77" x 18" | 2,159.88 | |
| | | Shipping Included | | |
| | | Quote by Susann 10-8-09 | | |
| | | Quote for a quote month | | |
| | | Quote # 14512415 | | |
| | | see attached | | |
| | | | | |
| | | | | |
| | | | | |
| | | | | |
| | | | | |
| | | | | |
| | | | | |
| | | | | |
| | | | | |

DISPOSITION: Pick-up Mail Check FAX # 1-888-388-6344 PAGE TOTAL _____

REMARK: _____ GRAND TOTAL 4,838.13

ORIGINATOR (PRINT) Made L. Victoria
ADMINISTRATOR SIGNATURE [Signature]

DATE 10/8/09
DATE 10/8/09

BUDGET COORDINATOR _____ DATE _____
OTHER _____ DATE _____



P.O. Box 8030
APPLETON WI 54912-8030

Send Orders & Correspondence to:

SCHOOL SPECIALTY
PO BOX 1579
APPLETON WI 54912-1579

Toll Free Phone: (888) 388-3224
Toll Free Fax: (888) 388-6344

Corporate FID# 39-0971239

Quote

Page 1 of 1

Quote Number: 14512415
Quote Effective Date: 08-OCT-2009
Quote Expiration Date: 09-NOV-2009
Customer Number: 275645
PO Number:

Ship To:
PEREZ ELEMENTARY SCHOOL
500 SIERRA VISTA BLVD
LAREDO TX 78046-7710

Bill To:
UNITED INDEPENDENT SCHOOL DIST
201 LINDENWOOD DR
LAREDO TX 78045-2499

| Quantity | UOM | Quoted Item | Our Item (if different) | Description | Unit Price | Net Price | Extended Price (USD) |
|----------|-----|-------------|----------------------------|-------------|------------|-----------|-------------------------|
|----------|-----|-------------|----------------------------|-------------|------------|-----------|-------------------------|

The following item(s) will ship to:

**PEREZ ELEMENTARY SCHOOL
500 SIERRA VISTA BLVD
Attention: lourdes,maria**

| | | | | | | | |
|---|----|-----------|--------|---|---------|---------|---------|
| 2 | EA | 631980030 | 631980 | TROPHY CASE VARSITY OAK FLR CASE MIR BACK SLIDING | 2159.88 | 2159.88 | 4319.76 |
|---|----|-----------|--------|---|---------|---------|---------|

Taxes: \$0.00
Shipping/Handling: \$518.37
Total: \$4,838.13



P.O. Box 8030
APPLETON WI 54912-8030

Send Orders & Correspondence to:

SCHOOL SPECIALTY
PO BOX 1579
APPLETON WI 54912-1579

Toll Free Phone:(888) 388-3224
Toll Free Fax: (888) 388-6344

Corporate FID# 39-0971239

Quote

Page 1 of 1

Quote Number: 14512415
Quote Effective Date: 08-OCT-2009
Quote Expiration Date: 09-NOV-2009
Customer Number: 275645
PO Number:

Ship To: PEREZ ELEMENTARY SCHOOL
500 SIERRA VISTA BLVD
LAREDO TX 78046-7710

Bill To: UNITED INDEPENDENT SCHOOL DIST
201 LINDENWOOD DR
LAREDO TX 78045-2499

| Quantity | UOM | Quoted Item | Our Item (if different) | Description | Unit Price | Net Price | Extended Price (USD) |
|----------|-----|-------------|----------------------------|-------------|------------|-----------|-------------------------|
|----------|-----|-------------|----------------------------|-------------|------------|-----------|-------------------------|

The following item(s) will ship to:

PEREZ ELEMENTARY SCHOOL
500 SIERRA VISTA BLVD
Attention: lourdes,maria

| | | | | | | | |
|---|----|-----------|--------|---|---------|---------|---------|
| 2 | EA | 631980030 | 631980 | TROPHY CASE VARSITY OAK FLR CASE MIR BACK SLIDING | 2159.88 | 2159.88 | 4319.76 |
|---|----|-----------|--------|---|---------|---------|---------|

| | | |
|--|---------------------------|-------------------|
| | Taxes: | \$0.00 |
| | Shipping/Handling: | \$518.37 |
| | Total: | \$4,838.13 |

Discretionary Funds



UNITED INDEPENDENT SCHOOL DISTRICT Purchase Requisition

Page ___ to ___

Vendor Name and Address

R & M Refrigeration
Supply Inc.
420 Campus Christi
Phone No: 722-3515
Campus: Perley Rm NO: Office
Date: _____

| FUND/YR FUNC. | ORG. | PROGRAM CODE | LOCAL OPTION NUMBER | PROJECT OBJECT | SUB OBJECT | AMOUNT | BUDGET CODE | ACCOUNT CODE |
|---------------|------|--------------|---------------------|----------------|------------|--------|-------------|--------------|
| | | | | | | | | |
| | | | | | | | | |
| | | | | | | | | |
| | | | | | | | | |
| | | | | | | | | |
| | | | | | | | | |

| QTY | ITEM # | DESCRIPTION | UNITED PRICE WITH DISCOUNT | EXTENSION |
|-----|--------|--------------------|----------------------------|-----------|
| 1 | SM50A | ICE MACHINE 50lbs. | 1524.69 | |
| | | | | |
| | | | | |
| | | | | |
| | | | | |
| | | | | |
| | | | | |
| | | | | |
| | | | | |
| | | | | |
| | | | | |
| | | | | |
| | | | | |
| | | | | |
| | | | | |
| | | | | |
| | | | | |
| | | | | |
| | | | | |

DISPOSITION: Pick-up Mail Check FAX # _____ PAGE TOTAL _____

REMARK: _____ GRAND TOTAL 1,524.69

ORIGINATOR (PRINT) Mick L. Vickers DATE 10/2/03
ADMINISTRATOR SIGNATURE [Signature] DATE 10/8/03

BUDGET COORDINATOR _____ DATE _____
OTHER _____ DATE _____

R & M Refrigeration Supply Inc.

420 CORPUS CHRISTI TELS: 956/722-3515
LAREDO, TEXAS 78040 722-3454
FAX: 722-5516

INQUIRY No. _____
DATE 9/21/09

- QUOTATION -

TO U.I.S.D. Perez ELEM.

| QUANTITY | PART No. | DESCRIPTION | UNIT PRICE | AMOUNT |
|----------|----------|--------------------|------------|----------|
| 1 | SM50A | ICE MACHINE 50Lbs. | 1524.69 | 1,524.69 |
| | | | | |
| | | | | |
| | | | | |
| | | | | |
| | | | | |
| | | | | |
| | | | | |
| | | | | |
| | | | | |
| | | | | |
| | | | | |
| | | | | |
| | | | | |
| | | | | |
| | | | | |
| | | | | |
| | | | | |
| | | | | |
| | | | | |
| | | | | |

TERMS _____
 DELIVERY 3-5 DAYS
 PRICES ARE QUOTED F. O. B. _____
 BY JUAN JOSE

PRICES ARE BASED ON COSTS AND CONDITIONS
 EXISTING ON DATE OF QUOTATION AND ARE SUBJECT
 TO CHANGE BY THE SELLER BEFORE FINAL
 ACCEPTANCE. TYPOGRAPHICAL AND STENOGRAPHIC
 ERRORS SUBJECT TO CORRECTION. TERMS
 INCONSISTENT WITH THOSE STATED HEREIN WHICH
 MAY APPEAR ON PURCHASER'S FORMAL ORDER WILL
 NOT BE BINDING ON SELLER.
 QUOTE VALID FOR 30 DAYS.

R & M Refrigeration Supply Inc.

420 CORPUS CHRISTI
LAREDO, TEXAS 78040

TELS: 956/722-3515
722-3454
FAX: 722-5516

INQUIRY No. _____

DATE 9/21/09

- QUOTATION -

TO U.I.S.D. Perez ELEM.

| QUANTITY | PART No. | DESCRIPTION | UNIT PRICE | AMOUNT |
|----------|------------|-------------|------------|--------|
| 1 | A32588-020 | Water Pump | 287.50 | 287.50 |
| | | | | |
| | | | | |
| | | | | |
| | | | | |
| | | | | |
| | | | | |
| | | | | |
| | | | | |
| | | | | |
| | | | | |
| | | | | |
| | | | | |
| | | | | |
| | | | | |
| | | | | |
| | | | | |
| | | | | |
| | | | | |
| | | | | |
| | | | | |

TERMS _____

DELIVERY 7-10 DAYS

PRICES ARE QUOTED F. O. B. _____

BY JUAN JOSE

PRICES ARE BASED ON COSTS AND CONDITIONS EXISTING ON DATE OF QUOTATION AND ARE SUBJECT TO CHANGE BY THE SELLER BEFORE FINAL ACCEPTANCE, TYPOGRAPHICAL AND STENOGRAPHIC ERRORS SUBJECT TO CORRECTION. TERMS INCONSISTENT WITH THOSE STATED HEREIN WHICH MAY APPEAR ON PURCHASER'S FORMAL ORDER WILL NOT BE BINDING ON SELLER.
QUOTE VALID FOR 30 DAYS.

Manitowoc Q-Model 130 Series

| Model | Cube size | Ice production 24 hours | | Power kWh/100 lbs. |
|----------|-----------|-------------------------|------|--------------------|
| | | lbs. | kgs. | |
| QD-0132A | dice | 90 | 41 | 16.0 |
| QD-0133W | dice | 123 | 56 | 9.8 |
| QY-0134A | half-dice | 90 | 41 | 16.0 |
| QY-0135W | half-dice | 123 | 56 | 9.8 |

Water usage/100 lbs./45.4 kgs. of ice

Potable Water: 38.4 gallons, 146 liters • Water-cooled Condenser: 187 gallons, 708 liters

*"A" or "W" following model number indicates "Air" or "Water" condensing unit.

 Certified in Accordance with ARI Ice Storage Bins Certification Program, which is based on ARI Standard 820

Ice Machine Electric

115/60/1. (208-230/60/1 and 230/50/1 also available, consult factory)
115/60/1 ice machines are factory pre-wired with a 6' (180 cm) power cord and NEMA 5-15P-plug configuration. 208-230/60/1 ice machines are factory pre-wired with a 6' (180 cm) power cord only, no plug is supplied.

Total Amps:

| | |
|--------------------------|--------------------------|
| 115/60/1 | 208-230/60/1 |
| Air-cooled — 7.6 amps. | Air-cooled — 3.3 amps. |
| Water-cooled — 6.8 amps. | Water-cooled — 2.8 amps. |

Maximum fuse size:

Air and Water-cooled — 15 amps.

HACR-type circuit breakers can be used in place of fuses.

Specifications

BTU Per Hour:

2,100 (average) 3,300 (peak)

Compressor:

Nominal rating: 1/3 HP

Cupra-Nickel Condenser:

(Water-cooled models)
Adds protection from corrosive water elements.

Operating Limits:

- Ambient Temperature Range: 40° to 110°F (4.4° to 43.3°C)
- Water Temperature Range: 40° to 90°F (4.4° to 32.2°C)
- Water Pressure Ice Maker Water In: Min. 20 psi (137.9 kPA) Max. 80 psi (551.1 kPA)
- Condenser Inlet Water In: (Water cooled only) Min. 20 psi (137.9 kPA) Max. 150 psi (1,034.2 kPA)



Air Flow Front View

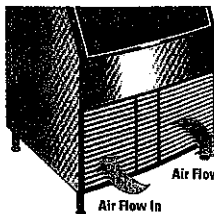

Air in left, air out right, no side vents.

Air Filter



Slides out from left side front without tools, easy to clean, reusable filter protects condenser from lint, grease and dust.

2 Cube Sizes Available



Half Dice
3/8" x 1 1/8" x 7/8"
(.95 x 2.86 x 2.22 cm)



Dice
7/8" x 7/8" x 7/8"
(2.22 x 2.22 x 2.22 cm)

| 24-HOUR PRODUCTION † | | | | | | | | lbs. kgs. |
|----------------------|------------|-----|-----|-------------------|------------|-----|-----|-----------|
| AIR-COOLED UNIT | | | | WATER-COOLED UNIT | | | | |
| air temp | water temp | | | air temp | water temp | | | |
| °F | 50° | 70° | 90° | °F | 50° | 70° | 90° | |
| °C | 10° | 21° | 32° | °C | 10° | 21° | 32° | |
| 70° | 130 | 110 | 95 | 70° | 147 | 127 | 108 | |
| 21° | 59 | 50 | 43 | 21° | 67 | 58 | 49 | |
| 80° | 120 | 105 | 90 | 80° | 144 | 126 | 106 | |
| 27° | 54 | 48 | 41 | 27° | 65 | 57 | 48 | |
| 90° | 105 | 90 | 80 | 90° | 140 | 123 | 103 | |
| 32° | 48 | 41 | 36 | 32° | 63 | 56 | 47 | |

†Production for Dice and Half Dice cubes.

- (A) Electrical Entrance
- (B) 3/8" (0.95 cm) F.P.T. Ice Making Water Inlet
- (C) 1/2" (1.27 cm) Minimum F.P.T. Water Condenser Outlet (water-cooled units)
- (D) 3/8" (0.95 cm) F.P.T. Water Condenser Inlet
- (E) 1/2" (1.27 cm) F.P.T. Bin Drain

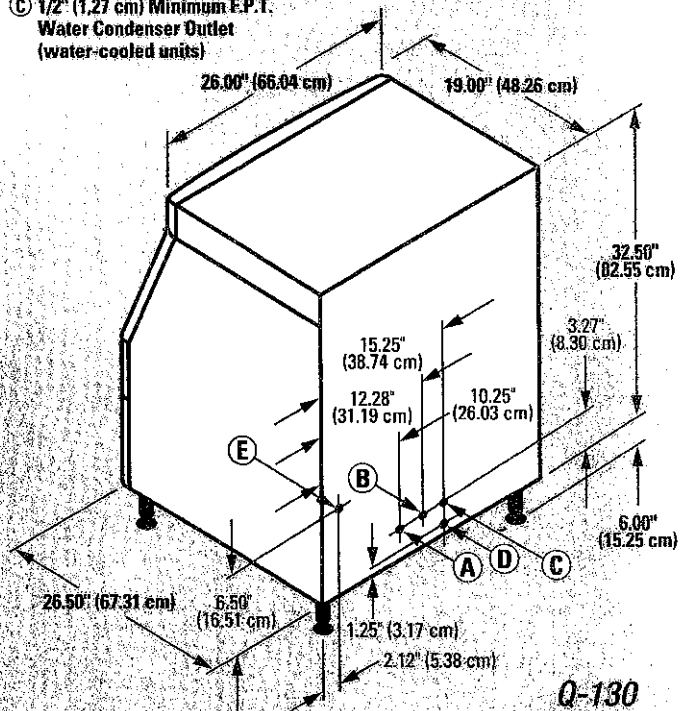

©2004 Manitowoc 21344-904. Continuing product improvement may necessitate change of specifications without notice.

Installation Note - Recommended clearance for top, sides, and back is 5" (12.7 cm) however, there is no minimum clearance required.

Front Access

Initiate ice, off and clean operations with simple upfront selector switch. No need to remove front panel.

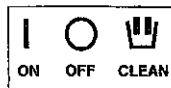

Manitowoc QM45 Series

| Model | Cube size | Ice production 24 hours | | Power kWh/100 lbs. |
|---|-----------|-------------------------|------|--------------------|
| | | lbs. | kgs. | |
| QM45A | dice | 65 | 30 | 14.9 |
| Water usage/100 lbs./45.4 kgs. of ice | | | | |
| Potable Water: 38.6 gallons, 146 liters | | | | |

*A following model number indicates "Air" cooled condensing unit.

 Certified in Accordance with ARI Ice Storage Bins Certification Program, which is based on ARI Standard 620

Ice Machine Electric

115/60/1. (230/50/1 also available.) 115/60/1 ice machines are factory pre-wired with a 6' (180 cm) power cord and NEMA 5-15P-plug configuration.

Total Amps: 5.2 amps.

Maximum fuse size: 15 amps.

HACR-type circuit breakers can be used in place of fuses.

Specifications

BTU Per Hour:

1,750 (average) 2,600 (peak)

Compressor:

Nominal rating: 1/4 HP

Operating Limits:

- Ambient Temperature Range: 35° to 110°F (1.6° to 43°C)

- Water Temperature Range: 33° to 90°F (0.6° to 32°C)

- Water Pressure Ice Maker Water In: Min. 20 psi (138 kPa) Max. 80 psi (551 kPa)

Legs:

Adjustable from 6.00"-7.25" (15.24-17.78 cm).

Ice Storage:

One piece bin liner (seamless) "rotocast" polyethylene.

Insulation:

Insulation foamed-in-place with CFC-FREE foam.



Air Flow Front View

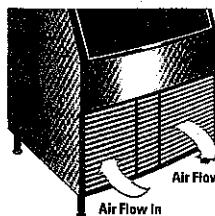

Air in left, air out right, no side vents.

Air Filter



Slides out from left side front without tools, easy to clean, reusable filter protects condenser from lint, grease and dust.

Cube Size



Dice
7/8" x 7/8" x 7/8"
(2.22 x 2.22 x 2.22 cm)

Front Access

Initiate, off and clean operations with simple upfront selector switch. No need to remove front panel.

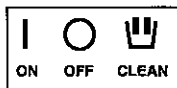

| 24-HOUR PRODUCTION † lbs. kgs. | | | |
|--------------------------------|------------|-----|-----|
| AIR-COOLED UNIT | | | |
| air temp | water temp | | |
| °F | 50° | 70° | 90° |
| °C | 10° | 21° | 32° |
| 70° | 95 | 80 | 70 |
| 21° | 43 | 36 | 32 |
| 80° | 90 | 75 | 65 |
| 27° | 41 | 34 | 30 |
| 90° | 80 | 65 | 55 |
| 32° | 36 | 30 | 25 |

†Production for Dice cubes.

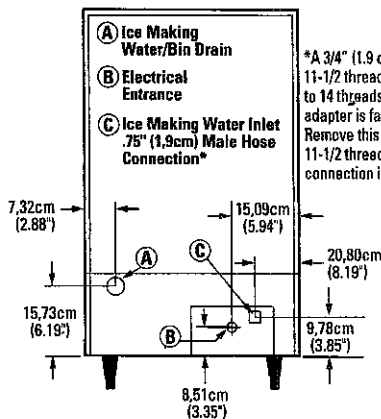
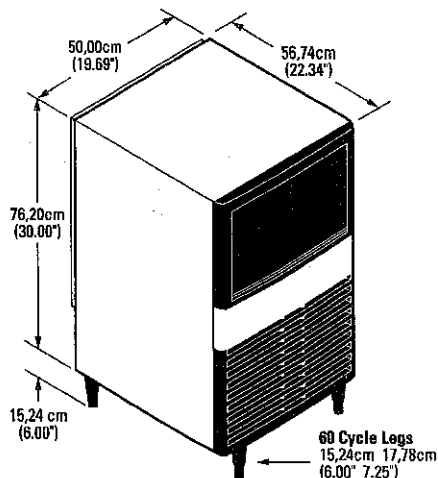

*A 3/4" (1.9 cm) by 11-1/2 threads per inch to 14 threads per inch adapter is factory installed. Remove this adapter if 11-1/2 threads per inch connection is desired.

QM45

Installation Note - There is no minimum clearance required, however recommended clearance for top, sides, and back is 5" (12.7 cm).

