

Your Effortless Solution



Locker Refurbishing, File Cabinets, and Metal Casework

Tara Bachtel
Scurry-Rosser ISD
10705 South State Highway 34
Scurry, TX 75158

June 18, 2015

Dear Ms. Bachtel,

Thank you for expressing an interest in ElectroCoat's exclusive locker repair and electrostatic textured refinishing process. We are pleased to provide you with the following estimate for locker restoration:

Repair and Refinish: (Exterior and Door Edge)

Building A

314 Republic Double Tier Locker Openings \$ 4,250.00

Building B

203 Interior Steel Double Tier Locker Openings \$ 2,850.00

Please Note: The above price does not include federal, state or local taxes of any kind. Price does not include new locks or replacement locker doors unless stated in bid. Please check for proper locker quantity.

Please review the technical specifications provided with this fax or on our website. If you would like to discuss this estimate in more detail, or if you would like to revise the requirements, contact us at your earliest convenience at 713-662-2900. Our fax number is 713-726-9494.

Sincerely,

A handwritten signature in blue ink, appearing to read "Thomas E. Dorman", is written over the word "Sincerely,".

Thomas E. Dorman
President

TD/ss

Please visit our website @ :
WWW.ELECTROPAINTER.COM

Your Effortless Solution

ELECTROCOAT

Locker Refurbishing, File Cabinets, and Metal Casework

Technical Specifications

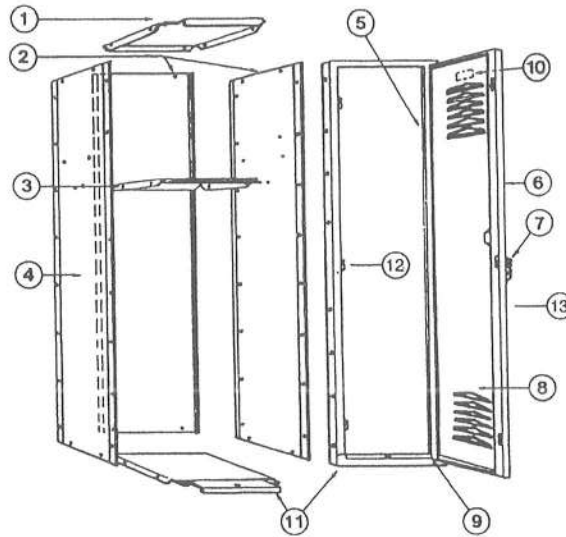

Repair Specifications

1. Repair tops as required.
2. Replace or tighten nuts and bolts as needed.
3. Repair all interior shelves.
(Some may need to be replaced.)
4. Straighten and rebolt end panels, or you may wish to replace ends with heavy duty panels.
5. Bolt and tighten all door frame assemblies.
6. Adjust all moving parts and lubricate.
7. Repair or replace missing handles.
8. Straighten all louvers.
9. Adjust, or if missing, replace hinges.
10. Replace missing number plates as required or (on total refurbishment), install all new tags.
11. Align and refasten lockers onto bases.
12. Adjust door frame latch and replace if needed.
13. Repair latch bars and fingers and replace as needed.
14. Adjust and straighten all existing and new doors to operate freely in the door frame opening so the doors will swing freely without binding.

(New parts will match existing parts when available.)

Your Effortless Solution

ELECTROCOAT

Locker Refurbishing, File Cabinets, and Metal Casework

Locker Refinishing: Preparation and Procedure

ElectroCoat shall provide all necessary labor, material and equipment to refinish lockers as follows:

1. Door operating hardware, built-in locks and number plates shall be removed or thoroughly masked before painting.
2. Surfaces to be painted will be adequately masked and protected from overspray.
3. All surfaces to be painted shall be sanded and washed with a proper agent to remove all dirt, grease and oil. "Feathering" will be done to assure a smoother job. All rusted surfaces will be sanded or wire brushed, thoroughly cleaned before painting. For an additional charge, lockers can either be spot primed or fully primed, as needed.
4. After masking is completed, the specified surfaces shall be painted with a hard durable two-part polyamide epoxy or polyurethane paint (special order), applied electrostatically.
5. The finish will have a minimum of three coats and will be textured unless otherwise specified. A smooth finish may require an extra charge.
6. Door edges and all exterior surfaces will be painted. (Interior painting of door or entire locker is available as an add-on.)
7. After allowing proper dry time, all masking and masking materials shall be removed. Handles, number tags and locks will be reinstalled.
8. Clean-up will be thorough with all overspray removed.

Guarantee

ElectroCoat guarantees the finish against defects in workmanship for one year. Guarantee covers flaking, peeling and chipping, not due to normal wear and tear. All repair work will be done according to our specifications to satisfy the owner and will be checked and approved at the time of job completion.

Commitment to Quality

ElectroCoat's objective is to provide our customers with the highest quality workmanship in the industry at competitive rates. We use the most advanced electrostatic equipment and finishes to turn your durable older lockers into lockers that look and perform like new ones. We advise our customers not to discard their investment made in older lockers (which were built with thicker gauges and metal latching mechanisms) for less durable new lockers which may use plastic mechanisms. We assure that our process will provide you with a smooth transition to "like-new" lockers.