

LENGTH OPTIONS

- 6' BENCH
- 8' BENCH

NOTES:

- 1.) ALL ALUM. & STL. MEMBERS COATED W/ ZINC RICH EPOXY THEN FINISHED W/ POLYESTER POWDER COATING.
- 2.) 1/2" X 3 3/4" EXPANSION ANCHOR BOLTS PROVIDED
- 3.) BENCH IS SHIPPED UNASSEMBLED.



DuMor, inc.

P.O. Box 142 Mifflintown, PA 17059-0142

SCALE :	NONE
DATE DRAWN :	09/24/12
DRAWN BY :	ESS
DATE REV. :	
REV. BY :	

TITLE :	BENCH	
REV.	A	DRAWING NUMBER
		446 SERIES
		SHEET
		1 OF 2

NOTE:

- 1.) DURING ASSEMBLY PROCEDURE;
DO NOT COMPLETELY TIGHTEN HARDWARE.
- 2.) THE ACTUAL PARTS WILL NOT BE NUMBERED:
NUMBERS ONLY APPLY TO DRAWING.

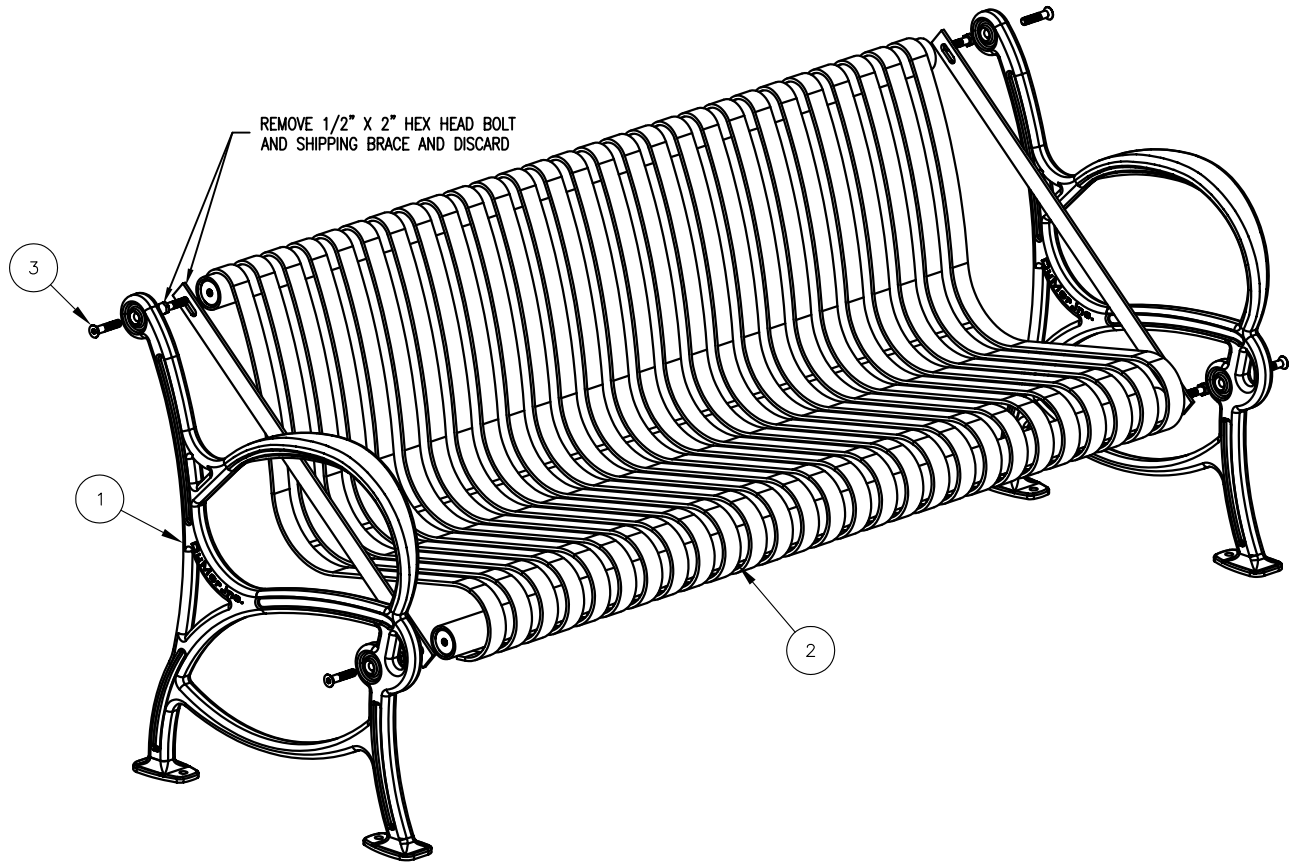

STEP 1:

- USE 2 - PCS. CAST ALUM SUPPORT (1)
 - 1 - PC. 6' ALL STL SEAT ASSEMBLY (2)
 - 4 - PCS. 1/2" X 2 1/2" FLT. SKT. HD. CAP SCR. (3)
- ATTACH CAST SUPPORT (1) TO 6' ALL STL SEAT ASSEMBLY (2) USING HARDWARE (3). TIGHTEN TO SNUG FIT.

STEP 2:

UPON COMPLETION OF BENCH ASSEMBLY SQUARE ALL COMPONENTS THEN TIGHTEN ALL HARDWARE.

STEP 3:

MOUNT AND ANCHOR AS SPECIFIED.

ITEM	QTY	PART NO	DESCRIPTION
1	2	0-446-00-01	CAST ALUM SUPPORT
2	1	0-93-60	6' STL SEAT ASSEMBLY
3	4	1-12-065	1/2" X 2 1/2" FLT SKT HD CAP SCR

 DuMor, inc. P.O. Box 142 Mifflintown, PA 17059-0142	SCALE :	NONE	TITLE :		BENCH ASSEMBLY	
	DATE DRAWN :	09/24/12	REV.	DRAWING NUMBER	446 SERIES	SHEET 2 OF 2
	DRAWN BY :	ESS	A			
	DATE REV. :					
	REV. BY :					