

PROSPECT HEIGHTS D23

2019 CLASSROOM FURNITURE CATALOG

	LIST PRICE
321 STUDENT DESK	\$393
321 LARGE SURFACE STUDENT DESK	\$439
ELEMENTAL KIDNEY	\$625
ELEMENTAL YIN YANG	\$745
ELEMENTAL RECTANGLE 30X48	\$405
ELEMENTAL RECTANGLE 30X60	\$505
ELEMENTAL RECTANGLE 30X72	\$525
SIT + STAND STUDENT DESK	\$908
OODLE STOOL	\$249
HOKKI STOOL*	\$85-102
FLAVORS STACK CHAIRS 18"	\$124
FLAVORS STACK CHAIRS 16"	\$110
FLAVORS STACK CHAIRS 14"	\$106
FLAVORS FIXED HEIGHT STOOL	\$165
UNTIED CHAIR - UPSWING	\$556
PLATO ADJUSTABLE STOOL	\$409

	LIST PRICE
CASCADE CUBBY UNIT OPEN	\$1,425
CASCADE CUBBY UNIT DOORS	\$1,637
CASCADE SHELVES UNIT OPEN	\$1,000
CASCADE SHELVES UNIT DOORS	\$1,213
CASCADE SHELVES & TOTES UNIT OPEN	\$1,590
CASCADE SHELVES & TOTES UNIT CLOSED	\$1,870
CASCADE 24 TOTES UNIT OPEN	\$1,615
CASCADE 24 TOTES UNIT CLOSED	\$1,847
BOOK TRUCK	\$528
CASCADE AV CART	\$1,925
CASCADE TEACHER DESK TOTES	\$946
CASCADE TEACHER DESK BOX FILE	\$905
SIT + STAND LECTERN	\$1,158
CASCADE MINI-CASE W/ LECTERN/TOTES	\$1,092
CASCADE MINI-CASE W/ LECTERN/SHELF	\$818

FOR BUDGETING PURPOSES USE LIST PRICE LESS 30%
LIST PRICING VALID UNTIL 12.31.19

*AS IS PRICE, SHIPPING INCLUDED WITH 6 OR MORE





interchange

3-2-1 student desk

MODEL #: 03002

DIMENSIONS + FREIGHT

MODEL #	D"	W"	H"	F.C.	CUBE	WEIGHT
03002	29.5"	40"	22" - 34"	70	1.9	55 lbs.
carton	31"	41"	3.25"			

OVERVIEW

The shape allows the 3-2-1 Desk to be arranged to fit the day's lesson plan. For a lecture or testing, 3-2-1 Desks can be lined up in rows; for group work, the tables can be arranged in partial and full circles. Best for pre-k through grade 2 cooperative learning classrooms.

The WORK SURFACE consists of a 45 lb density particle board core with a 0.030" high pressure laminated surface and a 0.020" melamine backer sheet. The edge of the work surface features a t-mold edge that is mechanically fastened to the underside of the work surface every 6 to 8 inches to assure a long lasting fit. 1 1/4" or 3/4" thick top.

The ELLIPSE LEGS are made out of 1" x 2" 14-gauge oval steel tubing which is protected with a durable powder coat finish that matches the color of the nylon cap. The legs are welded to a square brace and a plate for added surface contact and weight distribution. Includes 1" adjustable leveling glides with locking stops to provide stability on uneven floors.

INTERCHANGE TOP & EDGE PROFILE

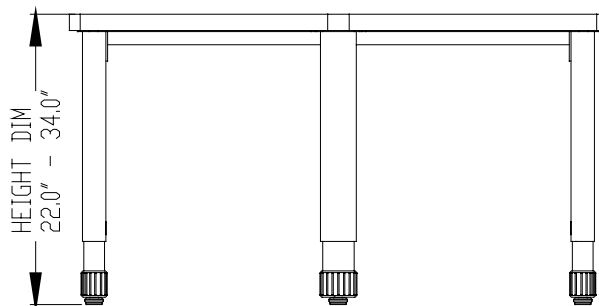
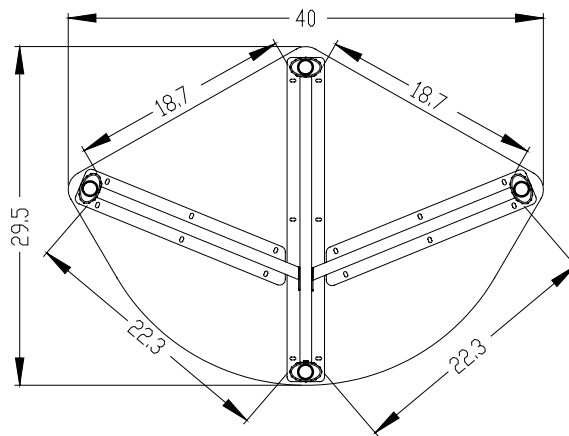
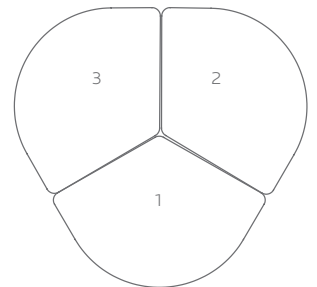
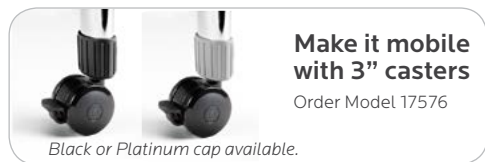
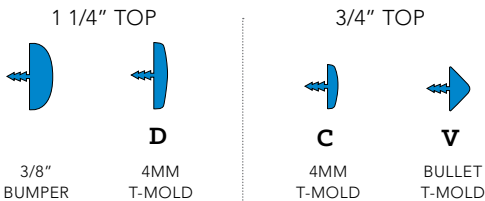



interchange

3-2-1 'Large Surface' student desk

MODEL #: 03011

DIMENSIONS + FREIGHT

MODEL #	D"	W"	H"	F.C.	CUBE	WEIGHT
03011	35.39"	50"	22" - 34"	70	2.4	67 lbs
carton	36"	60"	3.125"			
carton #2	36"	24"	4"			

OVERVIEW

The shape allows the 3-2-1 Desk to be arranged to fit the day's lesson plan. For a lecture or testing, 3-2-1 Desks can be lined up in rows; for group work, the tables can be arranged in partial and full circles. Best for pre-k through grade 2 cooperative learning classrooms.

The WORK SURFACE consists of a 45 lb density particle board core with a 0.030" high pressure laminated surface and a 0.020" melamine backer sheet. The edge of the work surface features a t-mold edge that is mechanically fastened to the underside of the work surface every 6 to 8 inches to assure a long lasting fit. 1 1/4" or 3/4" thick top.

The ELLIPSE LEGS are made out of 1" x 2" 14-gauge oval steel tubing which is protected with a durable powder coat finish that matches the color of the nylon cap. The legs are welded to a square brace and a plate for added surface contact and weight distribution. Includes 1" adjustable leveling glides with locking stops to provide stability on uneven floors.

INTERCHANGE TOP & EDGE PROFILE

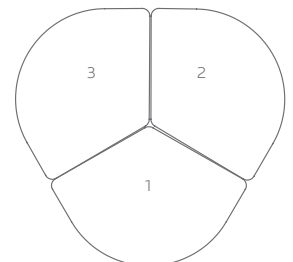
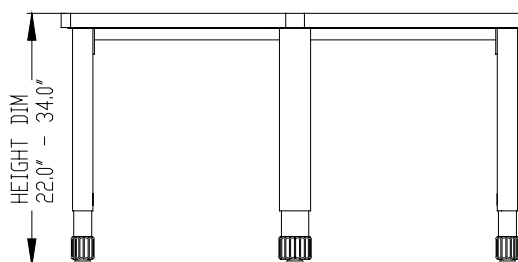
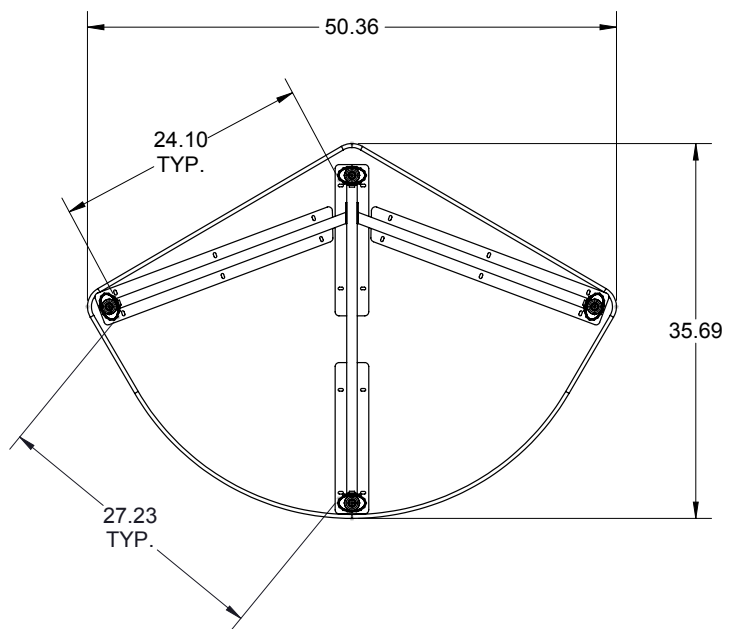
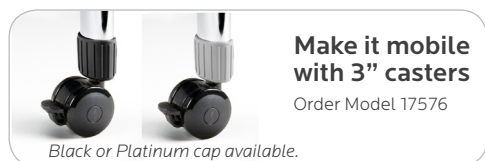
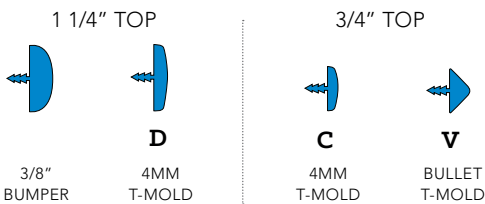

Frame Color Options



BLACK



PLATINUM

Standard Laminate Options

Want to specify a different laminate?

No problem. If you have 20 or more tops of the same color -60 or -38 there is no upcharge. Have 20 or less? We can quote for you with the Wilsonart code and – finish style. We can specify other laminates – call to inquire and get a quote.



Suggested Standard Laminates:



ASIAN NIGHT
7949-60



BOARDWALK OAK
7983-60



PEWTER MESH
4878-60



CLASSIC LINEN
4943-60



HIGH RISE
4996-60



BUKA BARK
7982-60



PALISADES OAK
7987-60



FLAX LINEN
4990-60



MISSION MAPLE
7990-60



NEW AGE OAK
7938-60

Classic Standard Laminates:



WILD CHERRY
7054-60



GREY NEBULA
4622-60



FUSION MAPLE
7909-60

All 13 of the standard laminates are -60 finish, if you need to match a laminate from a previous year, please let us know on your order (example Pewter Mesh 4878-38, our standard is -60).

When the WilsonArt Laminate code includes a "Y", "K", "-12" "-78", "Aeon" etc, these are special laminates with an upcharge, even when it contains -38 or -60.

Standard Edge Color Options



APPLE



BLACK



BLUEBERRY



BURGUNDY



CERULEAN



CHAMPAGNE



CHARCOAL



CHOCOLATE



CLEMENTINE



FOREST GREEN



FUCHSIA



MINT



MOCHA



NAVY



ORANGE



PERSIAN BLUE



PLATINUM



PURPLE



RED



YELLOW



elemental 48x72 kidney

MODEL #: EL4872 _ _ _ _ _EG

DIMENSIONS + FREIGHT

MODEL	DESCRIPTION	LEG TYPE	LEG #	D"	W"	H"	F.C.	CUBE	WT.
Kidney models									
EL4872 _ _ _ _ _EG	Kidney Table	Fixed Height	4 Legs	48	72	30	70	3.8	120
EL4872 _ _ _ _ _EC*	Kidney Table	Fixed Height for Caster	4 Legs	48	72	27**	70	3.8	124
EL4872 _ _ _ _ _EA	Kidney Table	Adjustable Height	4 Legs	48	72	19-33	70	3.8	123

*REMINDER: Casters sold separately.

**3" Casters make table height 30."

BUILD PART NUMBER

EL **4** **8** **7** **2** | **7** **8** **9** | **10** | **11** **12** **13** | **14** **15**

or **E8** Choose **MODEL**

Pick Laminate Color

Pick Edge Color

Pick Leg Color

Pick Leg Style
Fixed-height with Glide (EG) leg set is standard.

OVERVIEW

Elemental tables have optional colored casters and matching colored leg sets. The unique colored legs comes in three configurations; fixed height (EG), adjustable height (EA) and fixed height for use with casters (EC).

MATERIALS

The 1 1/4" thick WORK SURFACE consists of a 45 lb density particle board core with a 0.030" high pressure laminated surface and a 0.020" melamine backer sheet. The edge of the tabletop features your choice of a 3/8" bumper t-mold or 4mm t-mold, which is then fastened to the underside of the work surface every 6 to 8 inches to assure a long lasting fit. Mounted under the work surface is a 14 gauge steel STIFFENER for reinforcement.

LEG STYLE 14 15

- "EG" - Fixed-Height 30"
- "EC" - Fixed-Height 27" ** (use w/ 3" casters = 30"H).
- "EA" - Adjustable Height 19" - 33" (with glides)

The Elemental LEG SETS are constructed of 14-gauge steel with a durable powdercoat paint finish in one of five colors. The legs are reinforced by a gusseted, 'spade' shaped, mounting plate. Each one of the 4 legs attach to the pre-drilled holes in the top with 10 #10 x 5/8" screws per leg. Legs come standard with a nylon base glide.

OPTIONAL dual-wheel 3" casters available as a separate line item, 48"x72" Kidney Table uses 4-pack, Model 17576 for black, 17577 _ _ _ for colors: platinum, orange, cerulean, charcoal or apple.

NEW FOR 2017 ADD COLORED CASTERS

Model 17577 _ _ _ (4-pack)



*REMINDER: Casters sold separately! (17577 _ _ _ [4-pack])

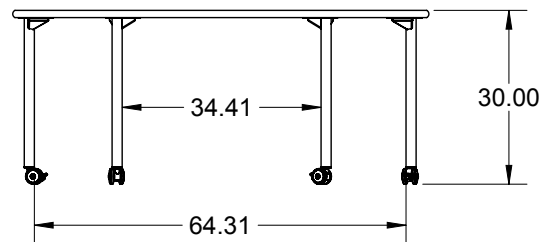
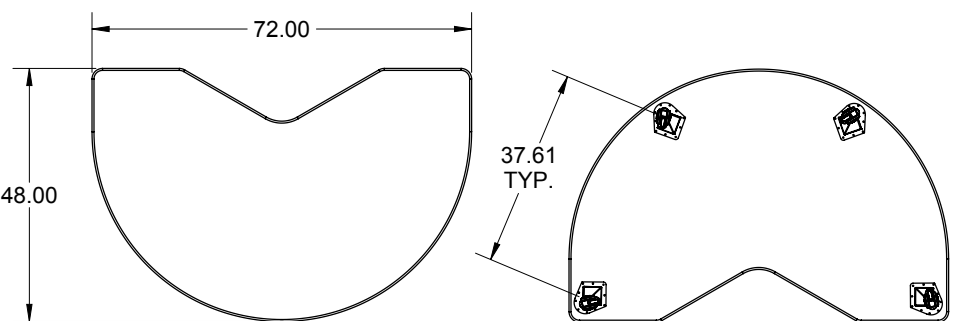

**drawings shown with 'EC' style legs, with optional 3" casters added.

**3" Casters make table height 30."

*REMINDER: Casters sold separately! (17577 _ _ _)



LEG STYLE: 14 15





elemental yin yang table

MODEL #: ELYNYG_ _ _ _ EG

DIMENSIONS + FREIGHT

MODEL	DESCRIPTION	LEG TYPE	LEG #	D"	W"	H"	F.C.	CUBE	WT.
<i>Yin Yang models</i>									
ELYNYG_ _ _ _ EG	Yin Yang Table	Fixed Height	4 Legs	64	54	30	70	4.2	90.5
ELYNYG_ _ _ _ EC*	Yin Yang Table	Fixed Height for Caster	4 Legs	64	54	27**	70	4.2	94.5
ELYNYG_ _ _ _ EA	Yin Yang Table	Adjustable Height	4 Legs	64	54	19-33	70	4.2	93.5

* REMINDER: Casters sold separately.

**3" Casters make table height 30."

BUILD PART NUMBER

EL **Y** **N** **Y** **G** **7** **8** **9** **10** **11** **12** **13** **14** **15**
 or **E8** Choose MODEL Pick Laminate Color Pick Edge Color Pick Leg Color Pick Leg Style
 Fixed-height with Glide (EG) leg set is standard.

OVERVIEW

Elemental tables have optional colored casters and matching colored leg sets. The unique colored legs comes in three configurations; fixed height (EG), adjustable height (EA) and fixed height for use with casters (EC).

MATERIALS

The 1 1/4" thick WORK SURFACE consists of a 45 lb density particle board core with a 0.030" high pressure laminated surface and a 0.020" melamine backer sheet. The edge of the tabletop features your choice of a 3/8" bumper t-mold or 4mm t-mold, which is then fastened to the underside of the work surface every 6 to 8 inches to assure a long lasting fit. Mounted under the work surface is a 14 gauge steel STIFFENER for reinforcement.

LEG STYLE **14** **15**

1. "EG" - Fixed-Height 30"
2. "EC" - Fixed-Height 27" ** (use w/ 3" casters = 30"H).
3. "EA" - Adjustable Height 19" - 33" (with glides)

The Elemental LEG SETS are constructed of 14-gauge steel with a durable powdercoat paint finish in one of five colors. The legs are reinforced by a gusseted, 'spade' shaped, mounting plate. Each one of the 4 legs attach to the pre-drilled holes in the top with 10 #10 x 5/8" screws per leg. Legs come standard with a nylon base glide.

OPTIONAL dual-wheel 3" casters available as a separate line item, Yin Ysng Table uses 4-pack, Model 17576 for black, 17577 _ _ _ for colors: platinum, orange, cerulean, charcoal or apple.

NEW FOR 2017 ADD COLORED CASTERS

Model 17577 _ _ _ (4-pack)



* REMINDER: Casters sold separately! (17577 _ _ _ [4-pack])

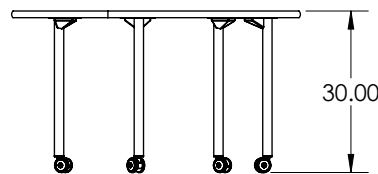
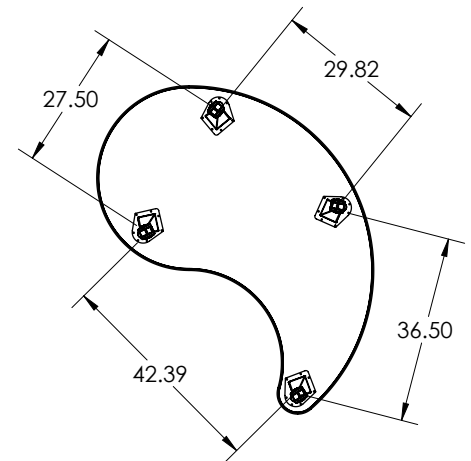
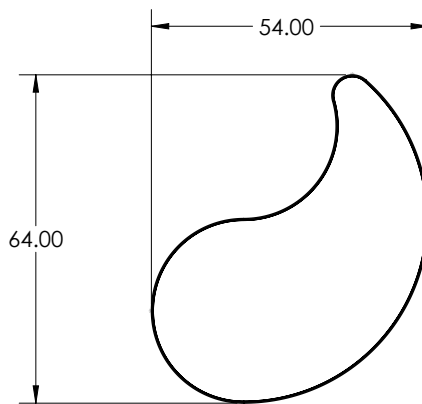

**drawings shown with 'EC' style legs, with optional 3" casters added.
 **3" Casters make table height 30."
 * REMINDER: Casters sold separately! (17577 _ _ _)



LEG STYLE: **14** **15**





elemental 30x48 rectangle

MODEL #: EL3048 _ _ _ _ EG

DIMENSIONS + FREIGHT

MODEL	DESCRIPTION	LEG TYPE	LEG #	D"	W"	H"	F.C.	CUBE	WT.
Rectangle models									
EL3048 _ _ _ _ EG	Rectangle Table	Fixed Height	4 Legs	30	48	30	70	1.9	66
EL3048 _ _ _ _ EC*	Rectangle Table	Fixed Height for Caster	4 Legs	30	48	27**	70	1.9	70
EL3048 _ _ _ _ EA	Rectangle Table	Adjustable Height	4 Legs	30	48	19-33	70	1.9	69

* REMINDER: Casters sold separately.

**3" Casters make table height 30"

BUILD PART NUMBER

EL **3** **0** **4** **8**
or
E8

Choose **MODEL**

Pick Laminate Color

Pick Edge Color

Pick Leg Color

Pick Leg Style
Fixed-height with Glide (EG) leg set is standard.

OVERVIEW

Elemental tables have optional colored casters and matching colored leg sets. The unique colored legs comes in three configurations; fixed height (EG), adjustable height (EA) and fixed height for use with casters (EC).

MATERIALS

The 1 1/4" thick WORK SURFACE consists of a 45 lb density particle board core with a 0.030" high pressure laminated surface and a 0.020" melamine backer sheet. The edge of the tabletop features your choice of a 3/8" bumper t-mold or 4mm t-mold, which is then fastened to the underside of the work surface every 6 to 8 inches to assure a long lasting fit. Mounted under the work surface is a 14 gauge steel STIFFENER for reinforcement.

LEG STYLE **14** **15**

- "EG" - Fixed-Height 30"
- "EC" - Fixed-Height 27" ** (use w/ 3" casters = 30"H).
- "EA" - Adjustable Height 19" - 33" (with glides)

The Elemental LEG SETS are constructed of 14-gauge steel with a durable powdercoat paint finish in one of five colors. The legs are reinforced by a gusseted, 'spade' shaped, mounting plate. Each one of the 4 legs attach to the pre-drilled holes in the top with 10 #10 x 5/8" screws per leg. Legs come standard with a nylon base glide.

OPTIONAL dual-wheel 3" casters available as a separate line item, 30"x48" Rectangle Table uses 4-pack, Model 17576 for black, 17577 _ _ _ for colors: platinum, orange, cerulean, charcoal or apple.

NEW FOR 2017 ADD COLORED CASTERS

Model 17577 _ _ _ (4-pack)



* REMINDER: Casters sold separately! (17577 _ _ _ [4-pack])

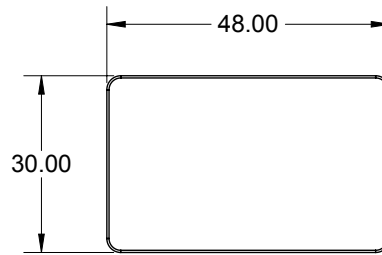

**drawings shown with 'EC' style legs, with optional 3" casters added.

**3" Casters make table height 30"

* REMINDER: Casters sold separately! (17577 _ _ _)

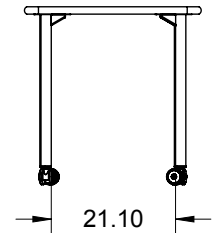
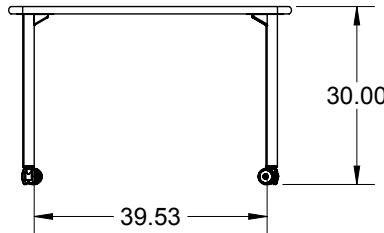

LEG STYLE: **14** **15**





elemental 30x60 rectangle

MODEL #: EL3060_ _ _ _ _EG

DIMENSIONS + FREIGHT

MODEL	DESCRIPTION	LEG TYPE	LEG #	D"	W"	H"	F.C.	CUBE	WT.
Rectangle models									
EL3060_ _ _ _ _EG	Rectangle Table	Fixed Height	4 Legs	30	60	30	70	2.3	79
EL3060_ _ _ _ _EC*	Rectangle Table	Fixed Height for Caster	4 Legs	30	60	27**	70	2.3	83
EL3060_ _ _ _ _EA	Rectangle Table	Adjustable Height	4 Legs	30	60	19-33	70	2.3	82

* REMINDER: Casters sold separately.

**3" Casters make table height 30."

BUILD PART NUMBER

EL **3** **0** **6** **0**
or
E**8** Choose MODEL

7 **8** **9** Pick Laminate Color

10 Pick Edge Color

11 **12** **13** Pick Leg Color

14 **15** Pick Leg Style
Fixed-height with Glide (EG) leg set is standard.

OVERVIEW

Elemental tables have optional colored casters and matching colored leg sets. The unique colored legs comes in three configurations; fixed height (EG), adjustable height (EA) and fixed height for use with casters (EC).

MATERIALS

The 1 1/4" thick WORK SURFACE consists of a 45 lb density particle board core with a 0.030" high pressure laminated surface and a 0.020" melamine backer sheet. The edge of the tabletop features your choice of a 3/8" bumper t-mold or 4mm t-mold, which is then fastened to the underside of the work surface every 6 to 8 inches to assure a long lasting fit. Mounted under the work surface is a 14 gauge steel STIFFENER for reinforcement.

LEG STYLE **14** **15**

1. "EG" - Fixed-Height 30"
2. "EC" - Fixed-Height 27" ** (use w/ 3" casters = 30"H).
3. "EA" - Adjustable Height 19" - 33" (with glides)

The Elemental LEG SETS are constructed of 14-gauge steel with a durable powdercoat paint finish in one of five colors. The legs are reinforced by a gusseted, 'spade' shaped, mounting plate. Each one of the 4 legs attach to the pre-drilled holes in the top with 10 #10 x 5/8" screws per leg. Legs come standard with a nylon base glide.

OPTIONAL dual-wheel 3" casters available as a separate line item, 30"x60" Rectangle Table uses 4-pack, Model 17576 for black, 17577 _ _ _ for colors: platinum, orange, cerulean, charcoal or apple.

NEW FOR 2017 ADD COLORED CASTERS

Model 17577 _ _ _ (4-pack)



* REMINDER: Casters sold separately! (17577 _ _ _ [4-pack])

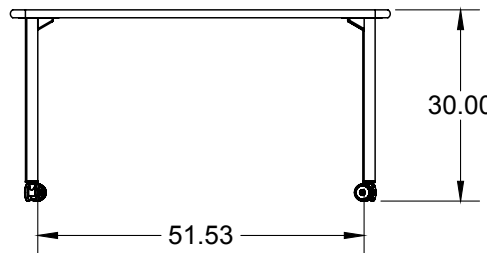
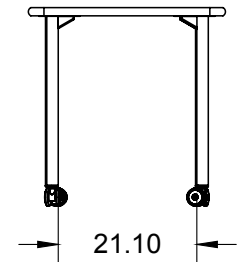
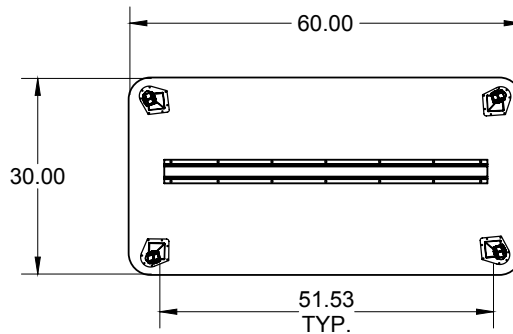

**drawings shown with 'EC' style legs, with optional 3" casters added.
 **3" Casters make table height 30."
 * REMINDER: Casters sold separately! (17577 _ _ _)



LEG STYLE: **14** **15**





elemental 30x72 rectangle

MODEL #: EL3072_ _ _ _ _EG

DIMENSIONS + FREIGHT

MODEL	DESCRIPTION	LEG TYPE	LEG #	D"	W"	H"	F.C.	CUBE	WT.
Rectangle models									
EL3072_ _ _ _ _EG	Rectangle Table	Fixed Height	4 Legs	30	72	30	70	2.6	98
EL3072_ _ _ _ _EC*	Rectangle Table	Fixed Height for Caster	4 Legs	30	72	27"	70	2.6	102
EL3072_ _ _ _ _EA	Rectangle Table	Adjustable Height	4 Legs	30	72	19-33	70	2.6	101

* REMINDER: Casters sold separately.

**3" Casters make table height 30."

BUILD PART NUMBER

EL 3 0 7 2
or E8
Choose MODEL

7 8 9 10
Pick Laminate Color
Pick Edge Color

11 12 13 14 15
Pick Leg Color
Pick Leg Style
Fixed-height with Glide (EG) leg set is standard.

OVERVIEW

Elemental tables have optional colored casters and matching colored leg sets. The unique colored legs comes in three configurations; fixed height (EG), adjustable height (EA) and fixed height for use with casters (EC).

MATERIALS

The 1 1/4" thick WORK SURFACE consists of a 45 lb density particle board core with a 0.030" high pressure laminated surface and a 0.020" melamine backer sheet. The edge of the tabletop features your choice of a 3/8" bumper t-mold or 4mm t-mold, which is then fastened to the underside of the work surface every 6 to 8 inches to assure a long lasting fit. Mounted under the work surface is a 14 gauge steel STIFFENER for reinforcement.

LEG STYLE 14 15

1. "EG" - Fixed-Height 30"
2. "EC" - Fixed-Height 27" ** (use w/ 3" casters = 30"H).
3. "EA" - Adjustable Height 19" - 33" (with glides)

The Elemental LEG SETS are constructed of 14-gauge steel with a durable powdercoat paint finish in one of five colors. The legs are reinforced by a gusseted, 'spade' shaped, mounting plate. Each one of the 4 legs attach to the pre-drilled holes in the top with 10 #10 x 5/8" screws per leg. Legs come standard with a nylon base glide.

OPTIONAL dual-wheel 3" casters available as a separate line item, 30"x72" Rectangle Table uses 4-pack, Model 17576 for black, 17577 _ _ _ for colors: platinum, orange, cerulean, charcoal or apple.

NEW FOR 2017 ADD COLORED CASTERS

Model 17577 _ _ _ (4-pack)



* REMINDER: Casters sold separately! (17577 _ _ _ [4-pack])

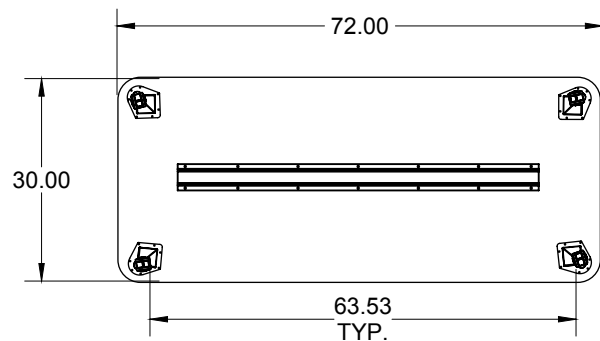

**drawings shown with 'EC' style legs, with optional 3" casters added.

**3" Casters make table height 30."

* REMINDER: Casters sold separately! (17577 _ _ _)

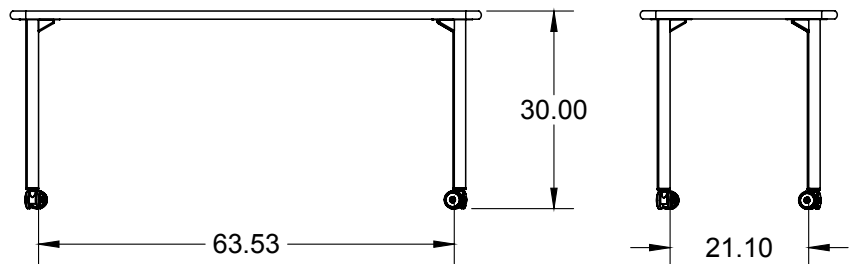

LEG STYLE: 14 15



Standard Laminate Options



EL or E8 **3 0 4 8** Choose **MODEL** **7 8 9** Pick Laminate Color **10** Pick Edge Color **11 12 13** Pick Leg Color **14 15** Pick Leg Style
Fixed-height with Glide (EG) leg set is standard.

Want to specify a different laminate?

No problem. If you have 20 or more tops of the same color -60 or -38 there is no upcharge. Have 20 or less? We can quote for you with the Wilsonart code and - finish style. We can specify other laminates - call to inquire and get a quote.



Suggested Standard Laminates: **7 8 9**

 ASIAN NIGHT 7949-60 ANG	 BOARDWALK OAK 7983-60 BWK	 PEWTER MESH 4878-60 PEW	 CLASSIC LINEN 4943-60 CLN	 HIGH RISE 4996-60 HRE
 BUKA BARK 7982-60 BBK	 PALISADES OAK 7987-60 PSO	 FLAX LINEN 4990-60 FLL	 MISSION MAPLE 7990-60 MIM	 NEW AGE OAK 7938-60 NEW

Classic Standard Laminates:

 WILD CHERRY 7054-60 CHE	 GREY NEBULA 4622-60 GNB	 FUSION MAPLE 7909-60 MAP
--	--	---



All 13 of the standard laminates are -60 finish, if you need to match a laminate from a previous year, please let us know on your order (example Pewter Mesh 4878-38, our standard is -60).

When the WilsonArt Laminate code includes a "Y", "K", "-12" "-78", "Aeon" etc, these are special laminates with an upcharge, even when it contains -38 or -60.

Standard Edge Color Options **10**

 APPLE A	 BLACK B	 BLUEBERRY C	 BURGUNDY D	 CERULEAN S	 CHAMPAGNE O
 CHARCOAL R	 CHOCOLATE Q	 CLEMENTINE E	 FOREST GREEN F	 FUCHSIA G	 MINT H
 MOCHA T	 NAVY I	 ORANGE U	 PERSIAN BLUE J	 PLATINUM P	 PURPLE K
 RED L	 YELLOW N				

Elemental Leg Colors **11 12 13**

 PLATINUM PLT	 CHARCOAL CGR	 ORANGE ORG	 APPLE APL	 CERULEAN CER
---	---	---	--	---

Elemental Leg Style **14 15**



**3\" Casters make table height 30\"
 *REMINER: Casters sold separately!
 (17577 _ _ _)

LEG STYLE:

1. "EG" - Fixed-Height 30"
2. "EC" - Fixed-Height 27"
(use w/ 3" casters = 30"H).
3. "EA" - Adjustable Height
(19" - 33" w/ glides)
(21.5" - 35.5" w/ 3" casters)



sit + stand student desk

MODEL #: 26547V, 26548V, 26549V

DIMENSIONS + FREIGHT

MODEL #	D"	W"	H"	F.C.	WEIGHT
26547v	20"	23.5"	26-41.5	85	40 lbs.
26548v	21"	30"	26-41.5	85	40 lbs.
26549v	20"	27"	26-41.5	85	40 lbs.

OVERVIEW

With active classrooms becoming more and more popular, the adaptability of student desks has become a necessity. With Sit + Stand, student's have the flexibility to choose their preferred position: sitting or standing.

MATERIALS

The 3/4" thick WORK SURFACE consists of a 45 lb density particle board core with a 0.030" high pressure laminated surface and a 0.020" melamine backer sheet. The edge of the tabletop features your choice of a bumper t-mold or 4mm t-mold, which is then fastened to the underside of the work surface every 6 to 8 inches to assure a long lasting fit.

COLUMN & BASE

The Sit + Stand desk has an adjustable column, that is gas assisted to lift from 26" to 41.5" in height, with the hand operated unit mounted on the right side of the desk.. The unit rolls smoothly on 3" dual-wheel casters, which each have a locking mechanism.

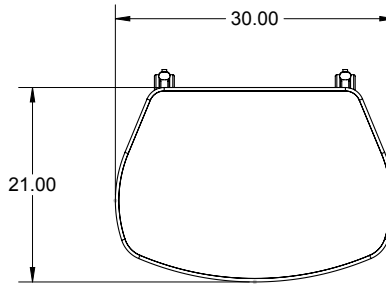

Model 26548 v
21"d x 30"w
Collaborative top.

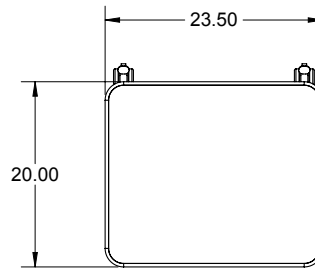
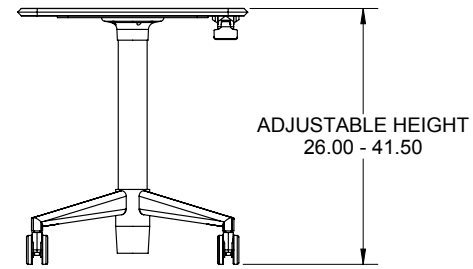

Model 26547v
20"d x 23.5"w Rectangle.

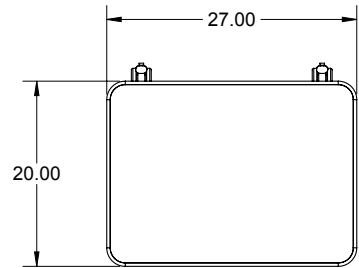

Model 26549 v
* 20"d x 27"w Rectangle.
* Model 26517 Modesty Panel not compatible with 20x27 desktop.

OPTIONAL ACCESSORIES



Model 76517 *
Modesty Panel / Privacy Screen

Product Dimensions: 1.5"d x 23.625"w x 13.75"h
Freight Class: 40
Cube: 1.44
Carton Dimensions: 13.75"d x 26"w x 1.5"h
Weight: 5 lbs.

*Model 26517 Modesty Panel not compatible with 20x27 desktop.

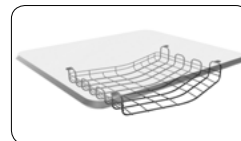
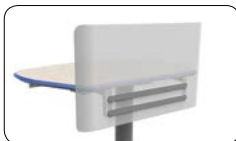

Model 76518
Technology Basket, low profile storage.

Product Dimensions: 10"d x 14"w x 3"h
Freight Class: 70
Cube: 1.44
Carton Dimensions: 10"d x 16"w x 3"h
Weight: 3 lbs.

Sit + Stand Column/Base Color



PLATINUM
PLT

Sit + Stand Has Top and Edge Choices

3/4" Tops



CHOICE 1

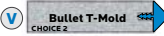

CHOICE 2

CHOICE 1 - 3/4" top with 4mm T-Mold **C** to follow Model No.

CHOICE 2 - 3/4" top with Bullet T-Mold **V** to follow Model No.

Standard Laminate Options

Want to specify a different laminate?

No problem. If you have 20 or more tops of the same color -60 or -38 there is no upcharge. Have 20 or less? We can quote for you with the Wilsonart code and - finish style. We can specify other laminates - call to inquire and get a quote.



Suggested Standard Laminates:

				
ASIAN NIGHT 7949-60 ANG	BOARDWALK OAK 7983-60 BWK	PEWTER MESH 4878-60 PEW	CLASSIC LINEN 4943-60 CLN	HIGH RISE 4996-60 HRE
				
BUKA BARK 7982-60 BBK	PALISADES OAK 7987-60 PSO	FLAX LINEN 4990-60 FLL	MISSION MAPLE 7990-60 MIM	NEW AGE OAK 7938-60 NEW

Classic Standard Laminates:

		
WILD CHERRY 7054-60 CHE	GREY NEBULA 4622-60 GNB	FUSION MAPLE 7909-60 MAP

All 13 of the standard laminates are -60 finish, if you need to match a laminate from a previous year, please let us know on your order (example Pewter Mesh 4878-38, our standard is -60).

When the WilsonArt Laminate code includes a "Y", "K", "-12" "-78", "Aeon" etc, these are special laminates with an upcharge, even when it contains -38 or -60.

Standard Edge Color Options

					
APPLE A	BLACK B	BLUEBERRY C	BURGUNDY D	CERULEAN S	CHAMPAGNE O
					
CHARCOAL R	CHOCOLATE Q	CLEMENTINE E	FOREST GREEN F	FUCHSIA G	MINT H
					
MOCHA T	NAVY I	ORANGE U	PERSIAN BLUE J	PLATINUM P	PURPLE K
					
RED L	YELLOW N				

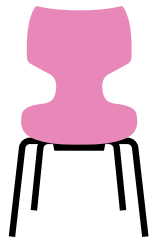

Seating

Seating is unique as a fingerprint. Students sit in thousands of different positions; upright, slouched, twisted and tilted. They stretch out their legs, sit on them, cross them and bounce them. They will balance on their chair or teeter on the back, tempting gravity — and common sense.

Built for Learning.





oodle stool

MODEL #: OODLE31 MODEL #: OODLE33

DIMENSIONS:

*UPS ELIGIBLE

MODEL #	D"	W"	H"	F.C.	CUBE	WT
OODLE31	17"	17"	18.5"	125	2.0	12 lbs.
OODLE33	17"	17"	18.5"	125	2.0	13 lbs.
OODLEBASE CGR	16"	16"	1"	70	1.0	3 lbs.
OODLEFELT	16" diameter			70		0.2 lbs.

OVERVIEW:

Students come in all shapes and sizes, in the design of oodle, we considered every body type. With 17" of seating surface, larger students will feel just as welcome using an oodle. The unique base design incorporates a structural disc, which when flipped 180° provides the student with the ability to wiggle.

But let's face it, active seating is not for every student (or every situation for that matter). For those students and situations, the movement disc is easy for a teacher to flip and remove movement from oodle.

To stack oodle or sit flat, turn the movement disc over to the flat side and lock in place.

The rocker base (structural disc) features a modest 10° of motion when engaged. With such an active seat, we designed oodle's edge to catch a student before he or she is able to lose their balance. And, of course, motion is optional on oodle, simply flip the rocker base back to flat to eliminate motion.

The oodle model "OODLE31" is sold with (3) three 6.5" high sections and (1) one rocker base. (additional rocker bases sold separately, Model "OODLEBASE CGR").

The oodle model "OODLE33" is sold with (3) three 6.5" sections and (3) three rocker bases. This setup allows each 6.5" section to be it's own 6.5" oodle.

(Oodle stools are ordered in 1 color, to mix and match colors, order multiple oodle's in alternating color schemes).

OPTIONAL ACCESSORIES:

OODLEBASE CGR

additional rocker base
sold separately
charcoal only

OODLEFELT

optional felt pad
for use on hard flooring
(including VCT)

Order additional rocker bases to create additional seats when needed. (additional rocker bases sold separately, Model "OODLEBASE CGR").

Order oodle felt pads when using oodle on hard flooring (including VCT) applications. (felt pads sold separately, Model "OODLEFELT").



*oodles are ordered in 1 color, to mix-match, order multiple color stools.

Shown above:
(1) OODLE31 CGR
(1) OODLE31 APL
(1) OODLE31 CER

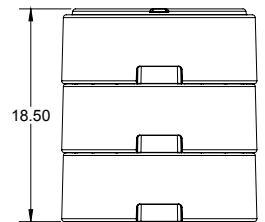
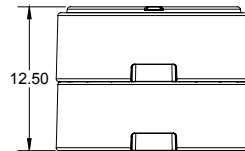
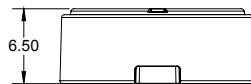
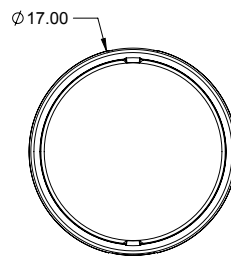

HEIGHT WITH ROCKER BASE DISENGAGED

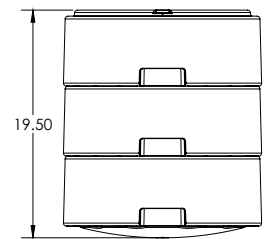
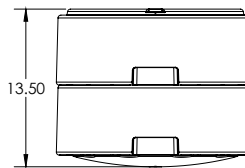
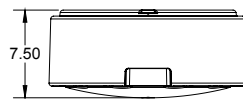

HEIGHT WITH ROCKER BASE ENGAGED
(10° MOTION)

OODLE COLOR OPTIONS



APPLE



CERULEAN



CHARCOAL



ORANGE



PLATINUM



flavors stack chairs

MODEL #: 11845, 11846, 11847, 11848, 11849



OVERVIEW

*BIFMA compliant.

Comfortable seat helps students keep proper posture and provides support for back and legs. Flat seat pan with waterfall front edge. Available in 6 sizes, 8", 10", 12", 14", 16" and 18". Chair shell comes in 18 colors and frame in Chrome or Platinum.

The SHELL is 100% virgin polypropylene material with a shallow seat pan allowing four-position seating for infinite seating styles. The back supplies rigid support while being specifically designed with added flexibility that adapts to individual requirements and supplies long lasting comfort. The shell includes an integrated handle molded in for easy movement of the chair.

The FRAME is constructed of strong 1" x 18-gauge tubing that is chrome plated for long lasting, durable finish is capped off with our durable nylon base swivel glides (steel and felt also available). The shell is attached to 16-gauge brackets via a metal to metal steel riveted connection and includes an integrated handle molded in for easy pick-up and moving of the chair.



OPTIONS

Nylon glide is standard.

Felt glide option : Add 'F' to follow Model No.

Steel glide option : Add 'S' to follow Model No.

(set of 4 installed - upcharge for felt or steel glide).

DIMENSIONS

*UPS ELIGIBLE

MODEL #	SHELL (H")	A	B	C	D	E	F	G	F.C.	CUBE	WEIGHT
11844	C (8")	18"	12"	13.5"	12"	15"	8"	11"	125	1.2	6 lbs.
11845	C (10")	20"	12"	13.5"	12"	15"	10"	11"	125	1.2	7 lbs.
11846	C (12")	22"	12"	14.5"	12"	15"	12"	11"	125	1.2	7 lbs.
11847	B (14")	26"	14.5"	17"	14.5"	17.5"	14"	13.75"	125	2.0	9 lbs.
11848	B (16")	29"	14.5"	18"	14.5"	17.5"	16"	13.75"	125	2.0	9 lbs.
11849	A (18")	31"	16"	20.5"	16"	19.5"	18"	15"	125	2.7	10 lbs.

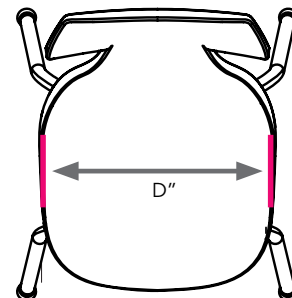
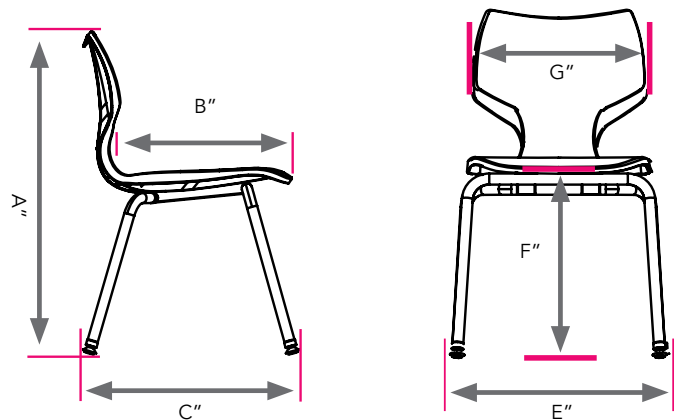



flavors fixed height stools

24" / 28" seat height

MODEL #: 11889, 11890



OVERVIEW

*BIFMA compliant.
Comfortable seat helps students keep proper posture and provides support for back and legs. Flat seat pan with waterfall front edge. Available in 2 sizes, 24"h and 28"h. Chair shell comes in 18 colors and frame in Chrome or Platinum w/ foot brace paint protector.

The SHELL is 100% virgin polypropylene material with a shallow seat pan allowing four-position seating for infinite seating styles. The back supplies rigid support while being specifically designed with added flexibility that adapts to individual requirements and supplies long lasting comfort. The shell includes an integrated handle molded in for easy movement of the chair.

The FRAME is constructed of strong 1" x 18-gauge tubing that is chrome plated for long lasting, durable finish is capped off with our durable nylon base swivel glides (steel and felt also available). The shell is attached to 16-gauge brackets via a metal to metal steel riveted connection and includes an integrated handle molded in for easy pick-up and moving of the chair.

OPTIONS

Nylon glide is standard.

Felt glide option : Add 'F' to follow Model No.
Steel glide option : Add 'S' to follow Model No.

(set of 4 installed - upcharge for felt or steel glide).

DIMENSIONS

*UPS ELIGIBLE

MODEL #	SHELL (H")	D"	W"	H"(A)	H"(B)	F.C.	CUBE	WEIGHT
11889	A(24")	18.28"	19"	24"	38"	125	2.0	12 lbs.
11890	A(28")	18.28"	19"	28"	42"	125	2.0	13 lbs.
	carton dims	27.125"	21.5"	42.25"	29"			

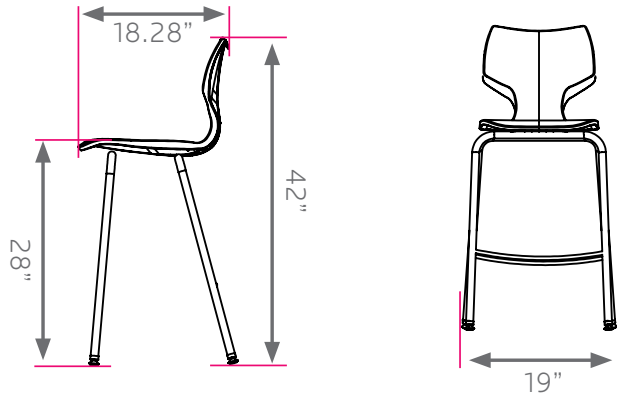

MODEL 11890 (28" SEAT HEIGHT)

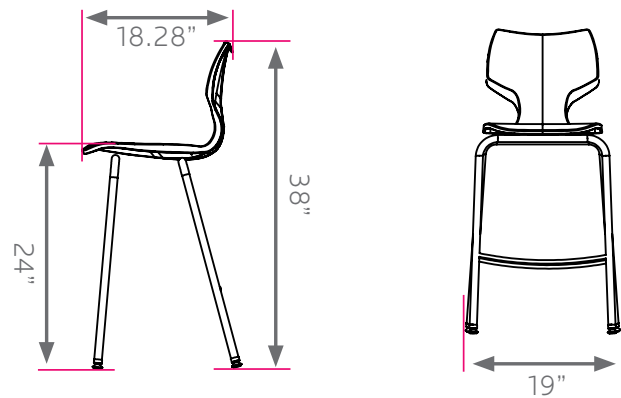

MODEL 11889 (24" SEAT HEIGHT)

Flavors™ Frame Color Options

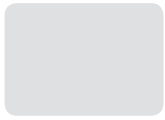

CHROME
CHR



PLATINUM
PLT

Flavors™ Shell Color Options



APPLE A



BLACK B



BLUEBERRY C



BURGUNDY D



CERULEAN S



CHARCOAL R



CHOCOLATE Q



CLEMENTINE E



FOREST GREEN F



FUCHSIA G



MINT H



MOCHA T



NAVY I



ORANGE U



PERSIAN BLUE J



PURPLE K



RED L



YELLOW N

Upswing

Task / Conference / Stool

PROFILE

- / Fully adjustable ergonomic task and stool seating, with or without arms
- / Choice of 5 mesh backrests colors
- / Adjustable lumbar support over a 2 1/2" (64 mm) range
- / Synchronous-tilt mechanism for noticeable smoothness in movement

- / Tilt lock mechanism with tension adjustment
- / Standard seat sliding mechanism provides 2 3/8" (60 mm) additional seat depth adjustment
- / Black nylon or optional polished chrome base
- / Optional 3D height adjustable arms with pivoting armrests

		SEAT			BACK		OVERALL			BETWEEN ARMS
		HEIGHT	WIDTH	DEPTH	HEIGHT	WIDTH	HEIGHT	WIDTH	DEPTH	
Task chair with arms	UP13	18 - 21 1/2 460 - 550	20 1/2 520	18 3/4 476	21 3/4 550	18 3/4 476	39 - 42 1/2 990 - 1080	26 660	26 - 28 660 - 710	19 1/4 490
Task chair without arms	UP12	18 - 21 1/2 460 - 550	20 1/2 520	18 3/4 476	21 3/4 550	18 3/4 476	39 - 42 1/2 990 - 1080	26 660	26 - 28 660 - 710	NA NA
Stool with arms	UP52	24 - 31 1/2 610 - 800	20 1/2 520	18 3/4 476	21 3/4 550	18 3/4 476	44 3/4 - 52 1/4 1140 - 1330	26 660	26 - 28 660 - 710	19 1/4 490
Stool without arms	UP51	24 - 31 1/2 610 - 800	20 1/2 520	18 3/4 476	21 3/4 550	18 3/4 476	44 3/4 - 52 1/4 1140 - 1330	26 660	26 - 28 660 - 710	NA NA

Cover: UP13 – TP11 Parrot & Raven Mesh Back (with adjustable arms)

MESH CHOICES FOR BACKRESTS



MUR - Raven **MUS** - Smoke **MUC** - Cloud **MUO** - Ocean **MUF** - Flame



Standard height adjustable lumbar support

Optional 3D arms



UP13
TP11 Parrot & Raven Mesh Back



UP13
TP10 Marigold & Smoke Mesh Back



UP12
TP05 Cinder & Ocean Mesh Back



UP52
TP01 Amaryllis & Cloud Mesh Back



United Chair® products comply with ANSI/BIFMA X5.1-2011 and ISO 14001:2004 standards. Information contained herein is subject to change without notice.

UNITED CHAIR® IS A PROUD MEMBER OF GROUPE LACASSE



1.888.522.2773
www.groupelacasse.com



Printed in Canada

3966
U454-0
6/17
10M



plato adjustable chair

MODEL #: 00960, 00961

DIMENSIONS + FREIGHT

MODEL #	D"	W"	H"	F.C.	CUBE	WEIGHT
00960 (glides)	25"	25"	16" - 21"	85	2.1	26 lbs.
00961 (casters)	25"	25"	16" - 21"	85	2.1	26 lbs.
carton dimension	27"	22"	43"			

* product is UPSable.

OVERVIEW

Plato seating offers the student comfort thanks to it's generous seat pan and seatback that provides some flex front-to-back and pronounced lumbar support, encouraging good posture and breathing on the part of the student. It's fresh, yet familiar shape connotes comfort to the student. The Adjustable Plato Chairs adjust from 16" to 21" in height, available in 18 colors and feature a 5-star base that comes in black. Available with glides or casters.

MATERIALS

The SHELL is 100% virgin polypropylene material with a shallow seat pan to allow side-to-side movement. The back has integrated lumbar support for optimum comfort and minimal back pressure.

The seat is secured to the FRAME with an 11-gauge plate mounted by 4 screws beneath the chair. The plate attaches to a pneumatic lift, which is a hydraulic cylinder that allows a full 360 degrees swivel. It comes with a black nylon base with a 25" diameter 5-star design and in a choice of 2" soft tread casters or glides.



Model 00960 shown, with glides.

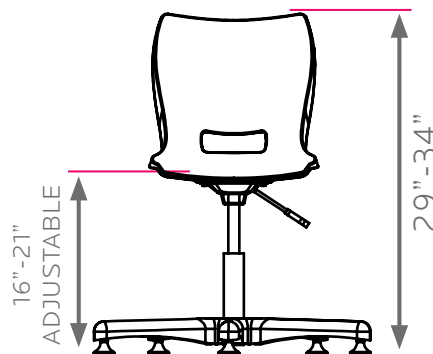
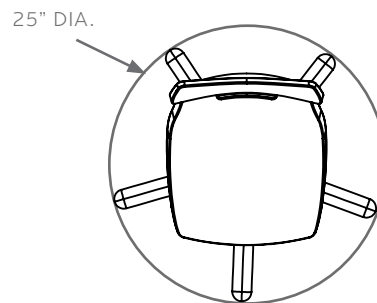

5-Star Adjustable Chair Base



BLACK
BLA

Plato™ Shell Color Options



MODEL 00960 (GLIDES)
MODEL 00961 (CASTERS)
ADJUSTABLE CHAIR



MODEL 00965 (GLIDES)
MODEL 00966 (CASTERS)
ADJUSTABLE STOOL

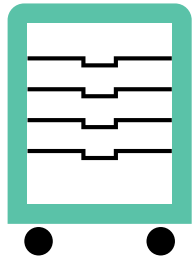

STORAGE

Imagine a classroom where four or five groups of six students are working on projects. The teacher circulates about, providing information, direction and encouragement. To allow for all this activity, materials and resources must be organized and readily available to students. Independent access to resources for students frees the teacher to direct and instruct as needed. That's the idea behind Cascade.

Built for Learning.





cascade mega-cabinet

cubby unit

MODEL #: E1100000P_ MODEL #: E2100000P_

MEGA-CABINET CUBBY

DIMENSIONS + FREIGHT

MODEL #		D"	W"	H"	F.C.	WEIGHT
E1100000P_	open, 9 cubby	19"	43"	43.4"	100	128 lbs.
E2100000P_	doors, 9 cubby	19"	43"	43.4"	100	147 lbs.

OVERVIEW

Featuring nine compartments and a selection of twenty beautiful finish colors, the Cascade Cubby offers an open-shelf layout with easy access for maximizing storage in any classroom setting. The powder coated all steel construction maximizes durability guarantying many years of service.

MATERIALS

The END PANELS are made of 18-gauge 1" square tubing, welding flush to an 18-gauge end panel. The inside of each end panel is reinforced by 22-gauge hat channels. These hat channels are dual-purpose: added strength and for tote rail shelf mounting. The dome top is 18-gauge formed and welded construction, bolted to each end panel and rear panel with a total of ten machine screw fasteners. The base is a durable 18-gauge steel construction formed and welded to support the entire weight of the unit squarely. Underneath is a heavy welded hat channel for reinforcement. The base shelf is attached to both end panels using four machine screw fasteners. The rear panel is 18-gauge steel reinforced with up to three vertical hat channels. Two grommet holes (a lower and an upper) are punched for convenient wire management and electronic storage. The 18-gauge cubby dividers bolt to the 16-gauge center supports that are bolted to the dome supports and hat channels. Casters are 5" in diameter, with two locking. Optional glides are 3/8" threaded stem.

RISER SHELVES are sized perfectly for each cabinet size. These riser shelves are made of 1 1/4" thick high-density particle board with your choice of laminate and bullet t-mold color. The shelf is suspended six inches above the dome top with four riser shelf handles, which measure 1-1/2": diameter and come in platinum powder coat finish (0.03" thickness). These riser shelf handles bolt on from underneath the dome top with four 3" washers.

The OPTIONAL DOORS include a secure and reliable locking mechanism, which engages lock rods into the dome top and the base shelf. Doors also come with urethane ergonomic and modern door handles of your color choice. The fully hinged doors articulate 270°, free of obstruction.

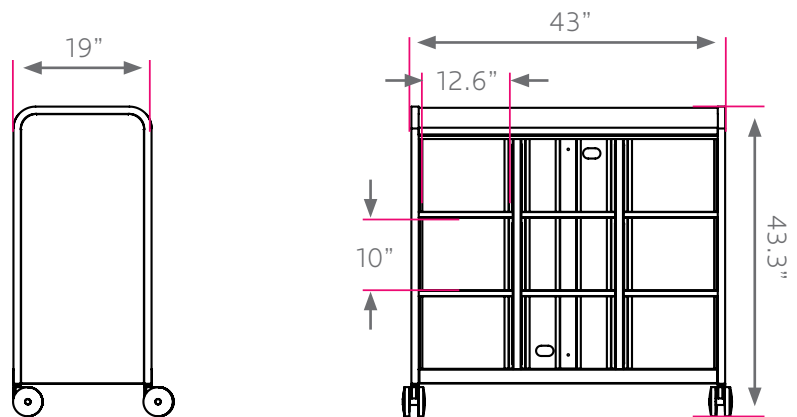



cascade mega-cabinet

with shelves

MODEL #: B3100000P_

MEGA-CABINET W/ SHELVES

OVERVIEW

The Cascade series provides storage for a wide variety of items. The Mega-Cabinet is a large width, medium height cabinet in the Cascade grouping, measuring in at 43 5/16" tall, 42 3/8" wide and 19" deep.

MATERIALS

The END PANELS are made of 18-gauge 1" square tubing, welded flush to an 18-gauge end panel. The inside of each end panel is reinforced by 22-gauge hat channels. These hat channels are dual purpose: added strength and for tote rail shelf mounting. The dome top is 18-gauge formed and welded construction, bolted to each end panel and rear panel with a total of 10 machine screw fasteners. The base is a durable 18-gauge steel construction formed and welded to support the entire weight of the unit squarely. Underneath is a heavy welded hat channel reinforcement. The base shelf is attached to both end panels using 4 machine screw fasteners. The Rear Panel is 18-gauge steel reinforced with up to three vertical hat channels. Two grommet holes (a lower and upper) are punched for convenient wire management and electronic storage. Casters are 5" in diameter, with 2 locking. Optional glides are 3/8" threaded stem.

RISER SHELVES are sized perfectly for each cabinet size. Mega-Cabinet riser shelves are made of 1 1/4" thick density particle board with your choice of laminate and T-Mold color. Shelf is suspended 6 inches above the dome top with 4 riser shelf handles, which measure 1 1/2" diameter and come in Platinum powder coat paint finish (0.03" Thickness). These riser shelf handles bolt on from underneath the dome top with a hefty 3" washer.

The optional DOORS include a secure and reliable locking mechanism, which engages lock rods into the dome top and the base shelf. Doors also come with urethane ergonomic and modern door handles of your color choice. The fully hinged doors articulate 270 degrees, free of obstruction.

WHITEBOARD BACK AVAILABLE!

Replace the 4th character in the part number with a "W" to denote a whiteboard back on the Cascade Mega-Cabinet.

i.e. 611W00000P_
B20W08040P_

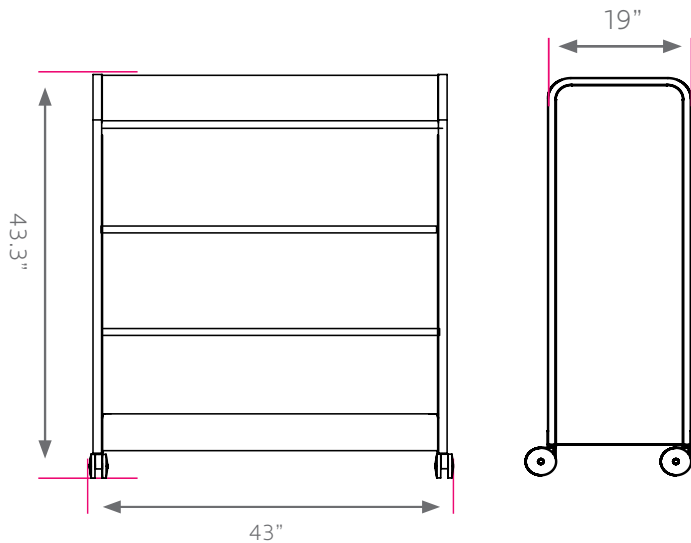

MEGA-CABINET W/ SHELVES

MODEL	DESCRIPTION		D"	W"	H"	F.C.	WT.
Shelves							
B3100000P_	Open w/shelves	w/glides	19	43	38.4	100	100
B4100000P_	Doors w/shelves	w/glides	19	43	38.4	100	119
B3110000P_---	Open w/shelves & riser	w/glides	19	43	45	100	126
B4110000P_---	Doors w/shelves & riser	w/glides	19	43	45	100	144
B1100000P_	Open w/shelves	w/casters	19	43	43.3	100	105
B2100000P_	Doors w/shelves	w/casters	19	43	43.3	100	124
B1110000P_---	Open w/shelves & riser	w/casters	19	43	50	100	131
B2110000P_---	Doors w/shelves & riser	w/casters	19	43	50	100	149
	pallet dimensions		26	45	43.9		

Note: When ordering a Riser Shelf for a Mega-Cabinet, 1 1/4" thick top is only option available.



cascade mega-cabinet

with totes & shelves

MODEL #: 612008000P_ / 622008000P_

MEGA-CABINET W/ TOTES & SHELVES

OVERVIEW

The Cascade series provides storage for a wide variety of items. The Mega-Cabinet is a large width, medium height cabinet in the Cascade grouping, measuring in at 43 5/16" tall, 42 3/8" wide and 19" deep.

MATERIALS

The END PANELS are made of 18-gauge 1" square tubing, welded flush to an 18-gauge end panel. The inside of each end panel is reinforced by 22-gauge hat channels. These hat channels are dual purpose: added strength and for tote rail shelf mounting.

The dome top is 18-gauge formed and welded construction, bolted to each end panel and rear panel with a total of 10 machine screw fasteners. The base is a durable 18-gauge steel construction formed and welded to support the entire weight of the unit squarely. Underneath is a heavy welded hat channel reinforcement. The base shelf is attached to both end panels using 4 machine screw fasteners. The Rear Panel is 18-gauge steel reinforced with up to three vertical hat channels. Two grommet holes (a lower and upper) are punched for convenient wire management and electronic storage. Casters are 5" in diameter, with 2 locking. Optional glides are 3/8" threaded stem.

RISER SHELVES are sized perfectly for each cabinet size. Mega-Cabinet riser shelves are made of 1 1/4" thick density particle board with your choice of laminate and T-Mold color. Shelf is suspended 6 inches above the dome top with 4 riser shelf handles, which measure 1 1/2" diameter and come in Platinum powder coat paint finish (0.03" Thickness). These riser shelf handles bolt on from underneath the dome top with a hefty 3" washer.

The optional DOORS include a secure and reliable locking mechanism, which engages lock rods into the dome top and the base shelf. Doors also come with urethane ergonomic and modern door handles of your color choice. The fully hinged doors articulate 270 degrees, free of obstruction.

WHITEBOARD BACK AVAILABLE!

Replace the 4th character in the part number with a "W" to denote a whiteboard back on the Cascade Mega-Cabinet.

i.e. 612W08000P_
622W08000P_

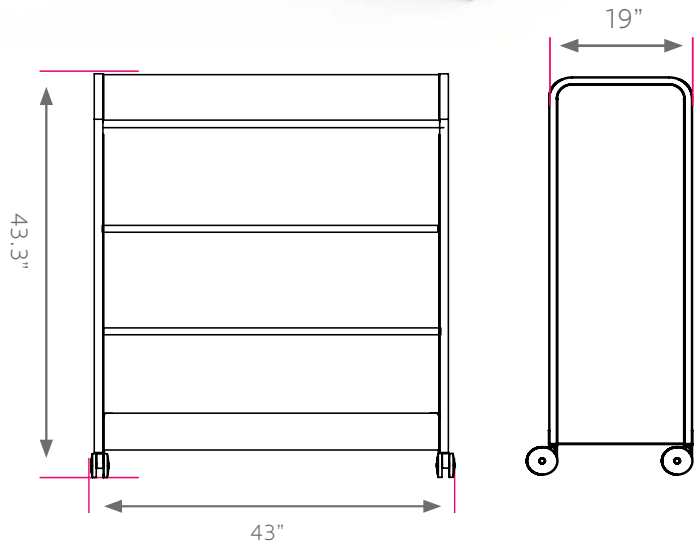

MEGA-CABINET W/ SHELVES

MODEL	DESCRIPTION		D"	W"	H"	F.C.	WT.
Totes & Shelves							
612008000P_	Open w/eight 3" SW totes & two shelves	w/casters	19	43	43.3	100	100
622008000P_	Doors w/eight 3" SW totes & two shelves	w/casters	19	43	43.3	100	119
	pallet dimensions		26	45	43.9		

Note: When ordering a Riser Shelf for a Mega-Cabinet, 1 1/4" thick top is only option available.



cascade mega-cabinet

with totes

MODEL #: 61002400P_

MEGA-CABINET W/ TOTES

OVERVIEW

The Cascade series provides storage for a wide variety of items. The Mega-Cabinet is a large width, medium height cabinet in the Cascade grouping, measuring in at 43 5/16" tall, 42 3/8" wide and 19" deep.

MATERIALS

The END PANELS are made of 18-gauge 1" square tubing, welded flush to an 18-gauge end panel. The inside of each end panel is reinforced by 22-gauge hat channels. These hat channels are dual purpose: added strength and for tote rail shelf mounting. The dome top is 18-gauge formed and welded construction, bolted to each end panel and rear panel with a total of 10 machine screw fasteners. The base is a durable 18-gauge steel construction formed and welded to support the entire weight of the unit squarely. Underneath is a heavy welded hat channel reinforcement. The base shelf is attached to both end panels using 4 machine screw fasteners. The Rear Panel is 18-gauge steel reinforced with up to three vertical hat channels. Two grommet holes (a lower and upper) are punched for convenient wire management and electronic storage. Casters are 5" in diameter, with 2 locking. Optional glides are 3/8" threaded stem.

RISER SHELVES are sized perfectly for each cabinet size. These riser shelves are made of 1 1/4" thick density particle board with your choice of laminate and T-Mold color. Shelf is suspended 6 inches above the dome top with 4 riser shelf handles, which measure 1 1/2" diameter and come in Platinum powder coat paint finish (0.03" Thickness). These riser shelf handles bolt on from underneath the dome top with a hefty 3" washer.

The optional DOORS include a secure and reliable locking mechanism, which engages lock rods into the dome top and the base shelf. Doors also come with urethane ergonomic and modern door handles of your color choice. The fully hinged doors articulate 270 degrees, free of obstruction.

WHITEBOARD BACK AVAILABLE!

Replace the 4th character in the part number with a 'W' to denote a whiteboard back on the Cascade Mega-Cabinet.

i.e. 611W0000P_
B20W08040P_



MEGA-CABINET W/ TOTES

MODEL	DESCRIPTION	D"	W"	H"	F.C.	WT.
Standard Width (SW) Totes		w/casters				
61002400P_	Open w/twenty-four 3" SW totes	19	43	43.3	100	132
62002400P_	Doors w/twenty-four 3" SW totes	19	43	43.3	100	150
61012400P_-----	Open w/twenty-four 3" SW totes & riser	19	43	50	100	158
62012400P_-----	Doors w/twenty-four 3" SW totes & riser	19	43	50	100	176
610012060P_	Open w/twelve 3" and six 6" SW totes	19	43	43.3	100	132
620012060P_	Doors w/twelve 3" and six 6" SW totes	19	43	43.3	100	150
610112060P_-----	Open w/twelve 3" and six 6" SW totes & riser	19	43	50	100	158
620112060P_-----	Doors w/twelve 3" and six 6" SW totes & riser	19	43	50	100	176
Extra Wide (EW) Totes		w/casters				
B10016000P_	Open w/sixteen 3" EW totes	19	43	43.3	100	132
B20016000P_	Doors w/sixteen 3" EW totes	19	43	43.3	100	150
B10116000P_-----	Open w/sixteen 3" EW totes & riser	19	43	50	100	158
B20116000P_-----	Doors w/sixteen 3" EW totes & riser	19	43	50	100	176
B1000080P_	Open w/eight 6" EW totes	19	43	43.3	100	132
B2000080P_	Doors w/eight 6" EW totes	19	43	43.3	100	150
B1010080P_-----	Open w/eight 6" EW totes & riser	19	43	50	100	158
B2010080P_-----	Doors w/eight 6" EW totes & riser	19	43	50	100	176
B10008040P_	Open w/eight 3" and four 6" EW totes	19	43	43.3	100	132
B20008040P_	Doors w/eight 3" and four 6" EW totes	19	43	43.3	100	150
B10108040P_-----	Open w/eight 3" and four 6" EW totes & riser	19	43	50	100	158
B20108040P_-----	Doors w/eight 3" and four 6" EW totes & riser	19	43	50	100	176
	pallet dimensions	26	45	43.9		

Note: When ordering a Riser Shelf for a Mega-Cabinet, 1 1/4" thick top is only option available.

Cascade Frame



PLATINUM

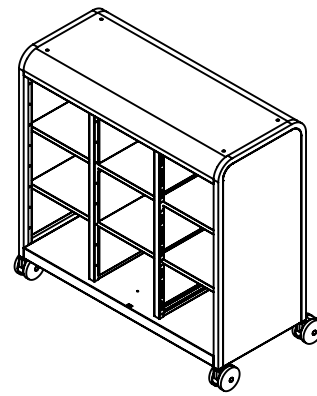

Standard Laminate Options *(Casade Riser Shelves)

Want to specify a different laminate?

No problem. If you have 20 or more tops of the same color -60 or -38 there is no upcharge. Have 20 or less? We can quote for you with the Wilsonart code and – finish style. We can specify other laminates – call to inquire and get a quote.



Suggested Standard Laminates:



ASIAN NIGHT
7949-60
ANG



BOARDWALK OAK
7983-60
BWK



PEWTER MESH
4878-60
PEW



CLASSIC LINEN
4943-60
CLN



HIGH RISE
4996-60
HRE



BUKA BARK
7982-60
BBK



PALISADES OAK
7987-60
PSO



FLAX LINEN
4990-60
FLL



MISSION MAPLE
7990-60
MIM



NEW AGE OAK
7938-60
NEW

Classic Standard Laminates:



WILD CHERRY
7054-60
CHE



GREY NEBULA
4622-60
GNB



FUSION MAPLE
7909-60
MAP

All 13 of the standard laminates are -60 finish, if you need to match a laminate from a previous year, please let us know on your order (example Pewter Mesh 4878-38, our standard is -60).

When the WilsonArt Laminate code includes a "Y", "K", "-12" "-78", "Aeon" etc, these are special laminates with an upcharge, even when it contains -38 or -60.

Cascade End Panel and Edge Color Options



APPLE **A**



BLACK **B**



BLUEBERRY **C**



BURGUNDY **D**



CERULEAN **S**



CHARCOAL **R**



CHOCOLATE **Q**



CLEMENTINE **E**



FOREST GREEN **F**



FUCHSIA **G**



MINT **H**



MOCHA **T**



NAVY **I**



ORANGE **U**



PERSIAN BLUE **J**



PLATINUM **P**



PURPLE **K**



RED **L**



YELLOW **N**



everything cart

18" x 36"

MODEL #: 21088

EVERYTHING CART, 2 SHELVES W/ 6 BINS

DIMENSIONS & FREIGHT

MODEL #	D"	W"	H"	F.C.	WEIGHT
21088	18"	36"	36"	150	70 lbs.
carton	19"	37.5"	33.5"		

OVERVIEW

The Everything™ Cart has two levels of double-face bins that can hold almost anything from books to art supplies, gym equipment and student works. They move easily through aisles on soft-tread dual wheel casters that won't shimmy like single wheels.

MATERIALS

Units come fully welded and assembled, just pop in the casters and they are ready to go. Everything Cart consists of (2) Frames, (2) End Panels and (2) shelves with 6 bins. The End Panels consist of 20-gauge steel full height panels welded to 1" square 18-gauge steel tubing Frame with formed in handles that radius for added comfort and ease of movement. The Shelves are constructed of 20-gauge steel shelves that are 34" long x 17 3/16" deep on each side and a 6" high back. The shelves have 20" clearance inbetween and are welded to the frames and end panels of the Book Truck. All Book Trucks feature 4" diameter dual wheel casters with soft tread for quiet operation. Dual wheels have no saddle that may damage surrounding furniture.

*not included - optional add-on

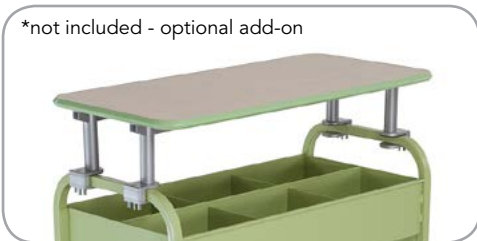

MODEL #	D"	W"	H"	F.C.	WEIGHT
21109	18"	38"	1.25"	70	19 lbs.

OPTIONAL BOOKTRUCK TOP #21109

Add this optional Booktruck Riser Shelf with 1 1/4" thick laminated top with either our 3/8" bumper or 4mm edge banding. The Riser-Poles clamp onto the booktruck handles and come in a Platinum finish. The shelf stands 6" above the booktruck handles.

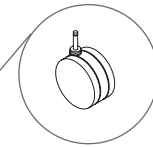

4" DIA. CASTERS

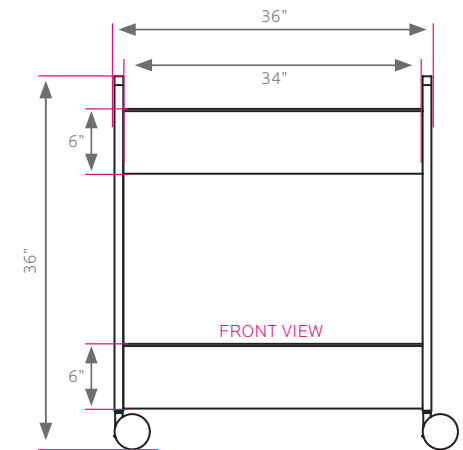
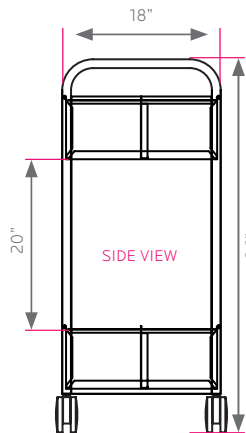
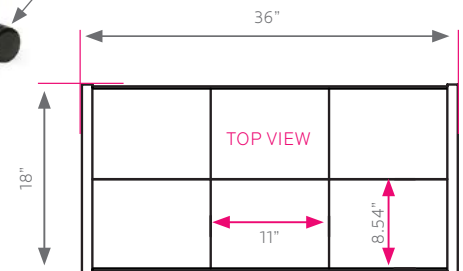

QS (QUICK-SHIP) BOOKTRUCK COLORS

Quickship colors up to 5. If more than 5, 8 week lead



BLACK



PERSIAN BLUE



PLATINUM



RED



SAND

EXTENDED LEADTIME BOOKTRUCK COLORS

8-Week lead-time colors.



APPLE



CERULEAN



CLEMENTINE



FOREST GREEN



NAVY



PURPLE



cascade mid-case av cart

MODEL #: W21100000P_

MID-CASE AV CART W/ RISER SHELF

DIMENSIONS + FREIGHT

MODEL #	D"	W"	H"	F.C.	CUBE	WEIGHT
W21100000P	19"	29"	37"	100	22	104 lbs.
pallet dims	26"	34"	32"			

OVERVIEW

The Cascade mid-case AV Presentation Cart provides movable, lockable storage for AV equipment and a durable work surface. Includes 4 Power Outlets outside, 5 Power Outlets inside as well as 4 wire holes and a perforated rear vent panel.

The END PANELS are made of 18-gauge 1" square tubing, welded flush to an 18-gauge end panel. The inside of each end panel is reinforced by 22-gauge hat channels. These hat channels are dual purpose: added strength and for tote rail shelf mounting. The dome top is 18-gauge formed and welded construction, bolted to each end panel and rear panel. The base is a durable 18-gauge steel construction formed and welded to support the entire weight of the unit squarely. Underneath is a heavy welded hat channel reinforcement. The base shelf is attached to both end panels. The Rear Panel is 18-gauge steel reinforced. Two grommet holes (a lower and upper) are punched for convenient wire management and electronic storage. Casters are 5" in diameter, with 2 locking. Optional glides are 3/8" threaded stem.

RISER SHELVES are sized perfectly for each cabinet size. These riser shelves are made of 1 1/4" high density particle board with your choice of laminate and T-Mold color. Shelf is suspended 6 inches above the dome top with 4 riser shelf handles, which measure 1 1/2" diameter and come in Platinum powder coat paint finish (0.03" Thickness). These riser shelf handles bolt on from underneath the dome top with a hefty 3" washer.

The DOORS include a secure and reliable locking mechanism, which engages lock rods into the dome top and the base shelf. Doors also come with urethane ergonomic and modern door handles of your color choice. The fully hinged doors articulate 270 degrees, free of obstruction.

RISER TOP & EDGE PROFILE

1 1/4" TOP



N

3/8"
BUMPER



Q

4MM
T-MOLD

Mid-Case AV with riser available with 1 1/4" top only.

Choice N is standard edge. For optional edge option Q, replace N with Q in model number.

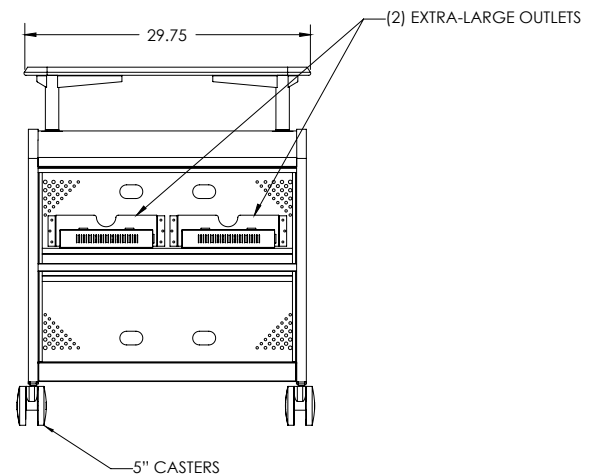
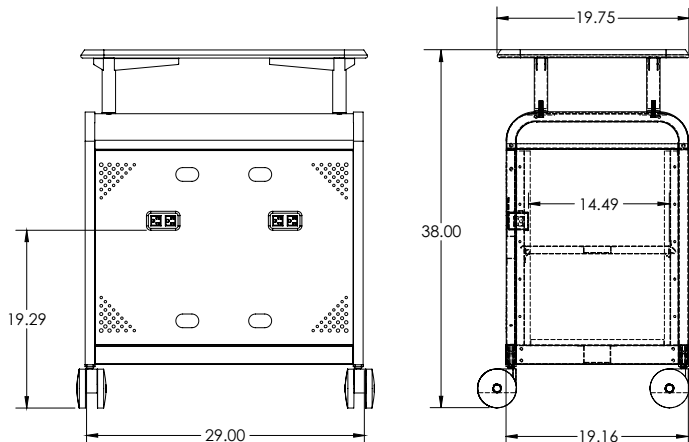

Cascade Frame



PLATINUM

Standard Laminate Options *(Casade Riser Shelves)

Want to specify a different laminate?

No problem. If you have 20 or more tops of the same color -60 or -38 there is no upcharge. Have 20 or less? We can quote for you with the Wilsonart code and – finish style. We can specify other laminates – call to inquire and get a quote.



Suggested Standard Laminates:



ASIAN NIGHT
7949-60
ANG



BOARDWALK OAK
7983-60
BWK



PEWTER MESH
4878-60
PEW

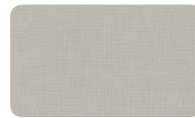

CLASSIC LINEN
4943-60
CLN



HIGH RISE
4996-60
HRE



BUKA BARK
7982-60
BBK



PALISADES OAK
7987-60
PSO



FLAX LINEN
4990-60
FLL



MISSION MAPLE
7990-60
MIM



NEW AGE OAK
7938-60
NEW

Classic Standard Laminates:



WILD CHERRY
7054-60
CHE



GREY NEBULA
4622-60
GNB



FUSION MAPLE
7909-60
MAP

All 13 of the standard laminates are -60 finish, if you need to match a laminate from a previous year, please let us know on your order (example Pewter Mesh 4878-38, our standard is -60).

When the WilsonArt Laminate code includes a "Y", "K", "-12" "-78", "Aeon" etc, these are special laminates with an upcharge, even when it contains -38 or -60.

Cascade End Panel and Edge Color Options



APPLE **A**



BLACK **B**



BLUEBERRY **C**



BURGUNDY **D**



CERULEAN **S**



CHARCOAL **R**



CHOCOLATE **Q**



CLEMENTINE **E**



FOREST GREEN **F**



FUCHSIA **G**



MINT **H**



MOCHA **T**



NAVY **I**



ORANGE **U**



PERSIAN BLUE **J**



PLATINUM **P**



PURPLE **K**



RED **L**



YELLOW **N**

Cascade® Teacher Desks



Cascade mini-case, lectern page 238



21096 Book Cart page 248



Cascade Mega-tower page 219



Cascade Teacher Desk page 242

Theorem Mobile Stack Chair page 39

The essentials
for teacher success.

smithsystem.com/furniture-types/teacher



cascade teacher desk

right position tote pedestal w/ door

MODEL #: 26157

RECTANGLE, CABINET W/ DOOR,
RIGHT-HAND

DIMENSIONS + FREIGHT

MODEL #	D"	W"	H"	F.C.	CUBE	WEIGHT
26157	24"	54"	30.25"	70		129 lbs.
carton #1	25"	63"	3"	shipping weight 189 lbs.		
carton #2	16.5"	21.5"	27"			

OVERVIEW

The Cascade Teacher Desk offers a stable, mobile and versatile workspace with integrated wireway and modesty panel plus the unique capabilities of Cascade storage. It offers a scalable solution for organization, storage and distribution of learning materials.

The 1 1/4" thick WORK SURFACE consists of a 45 lb. density particle board core with a .030" high-pressure laminated surface and a .020" melamine backer sheet. The edge of the work surface features a bumper edge molding (choices listed below) that is mechanically fastened every 6 to 8 inches to assure a long lasting fit.

The PEDESTAL is constructed of fully welded 20 gauge steel components and comes standard with 3" plate casters. Each plate caster takes 4 machine screws to fasten to the ped. The single TOTE PEDESTAL is configured with (2) 3" and (1) 12" translucent totes and a locking door for security, on the right-hand side of the desk. The leg is 1 5/8" x 10" double wall panel of 12-, 14- and 18-gauge steel with rounded edges and a 16-gauge steel tube 1 3/4" x 2" base. The 18-gauge steel modesty panel is mechanically fastened to the pedestals and to the laminated top.

CASCADE TOP & EDGE PROFILE

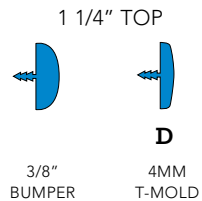

TOTE TRAY CONFIGURATION:

- (2) SW 3" Totes
- (1) SW 12" Tote

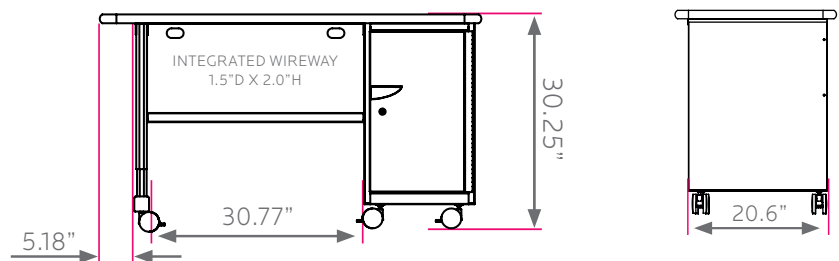
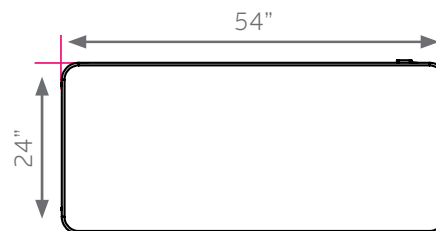



cascade teacher desk

box-box-file single right pedestal

MODEL #: 26159

RECTANGLE, BOX-BOX-FILE, RIGHT-HAND

DIMENSIONS + FREIGHT

MODEL #	D"	W"	H"	F.C.	CUBE	WEIGHT
26159	24"	54"	30.25"	70		142 lbs.
carton #1	25"	63"	3"	shipping weight 202 lbs.		
carton #2	26"	21"	32"			

OVERVIEW

The Cascade Teacher Desk offers a stable, mobile and versatile workspace with integrated wireway and modesty panel plus the unique capabilities of Cascade storage. It offers a scalable solution for organization, storage and distribution of learning materials.

The 1 1/4" thick WORK SURFACE consists of a 45 lb. density particle board core with a .030" high-pressure laminated surface and a .020" melamine backer sheet. The edge of the work surface features a bumper edge molding (choices listed below) that is mechanically fastened every 6 to 8 inches to assure a long lasting fit.

The PEDESTAL is constructed of fully welded 20 gauge steel components and comes standard with 3" plate casters. Each plate caster takes 4 machine screws to fasten to the ped. The single BOX-BOX-FILE PEDESTAL has drawers on ball bearing slides and a lock for security. The leg is 1 5/8" x 10" double wall panel of 12-,14- and 18-gauge steel with rounded edges and a 16-gauge steel tube 1 3/4" x 2" base. The 18-gauge steel modesty panel is mechanically fastened to the pedestals and to the laminated top.

CASCADE TOP & EDGE PROFILE

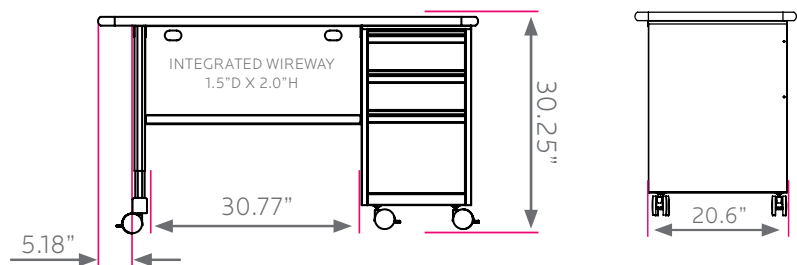
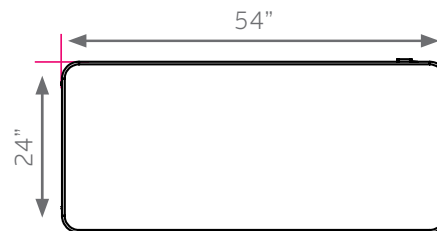
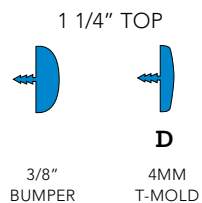

Cascade Teacher Desk Frame Color Options



BLACK
BLA



PLATINUM
PLT

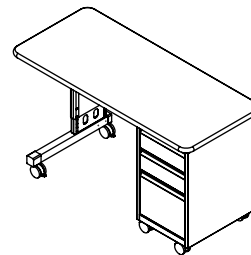

Standard Laminate Options

Want to specify a different laminate?

No problem. If you have 20 or more tops of the same color -60 or -38 there is no upcharge. Have 20 or less? We can quote for you with the Wilsonart code and – finish style. We can specify other laminates – call to inquire and get a quote.



Suggested Standard Laminates:



ASIAN NIGHT
7949-60
ANG



BOARDWALK OAK
7983-60
BWK



PEWTER MESH
4878-60
PEW



CLASSIC LINEN
4943-60
CLN



HIGH RISE
4996-60
HRE



BUKA BARK
7982-60
BBK



PALISADES OAK
7987-60
PSO



FLAX LINEN
4990-60
FLL



MISSION MAPLE
7990-60
MIM



NEW AGE OAK
7938-60
NEW

Classic Standard Laminates:



WILD CHERRY
7054-60
CHE



GREY NEBULA
4622-60
GNB



FUSION MAPLE
7909-60
MAP

All 13 of the standard laminates are -60 finish, if you need to match a laminate from a previous year, please let us know on your order (example Pewter Mesh 4878-38, our standard is -60).

When the WilsonArt Laminate code includes a "Y", "K", "-12" "-78", "Aeon" etc, these are special laminates with an upcharge, even when it contains -38 or -60.

Standard Edge Color Options



APPLE A



BLACK B



BLUEBERRY C



BURGUNDY D



CERULEAN S



CHAMPAGNE O



CHARCOAL R



CHOCOLATE Q



CLEMENTINE E



FOREST GREEN F



FUCHSIA G



MINT H



MOCHA T



NAVY I



ORANGE U



PERSIAN BLUE J



PLATINUM P



PURPLE K



RED L



YELLOW N

Smith System®

MODEL 26159 - SEPTEMBER 2017



sit + stand lectern

MODEL #: 26552V, 26553V

DIMENSIONS + FREIGHT

MODEL #	D"	W"	H"	F.C.	WEIGHT
26552v	20"	23.5"	30-45	85	48 lbs.
26553v	21"	30"	30-45	85	48 lbs.

OVERVIEW

Our Sit + Stand Lectern unit provides a stylish, unique and convenient way for educator's to present learning material to students. With Sit + Stand, the user can have the flexibility to choose their preferred position: sitting or standing.

MATERIALS

The 3/4" thick WORK SURFACE consists of a 45 lb density particle board core with a 0.030" high pressure laminated surface and a 0.020" melamine backer sheet. The edge of the tabletop features your choice of a bumper t-mold or 4mm t-mold, which is then fastened to the underside of the work surface every 6 to 8 inches to assure a long lasting fit.

COLUMN & BASE

The Sit + Stand lectern unit has an adjustable column, that is gas assisted to lift from 30" to 45" in height. Adjustability is controlled with the hand operated unit mounted on the right side of the desk. The unit rolls smoothly on 3" dual-wheel casters, which each have a locking mechanism.

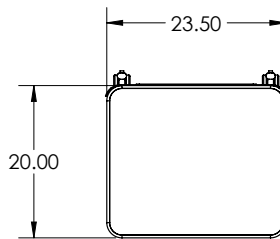
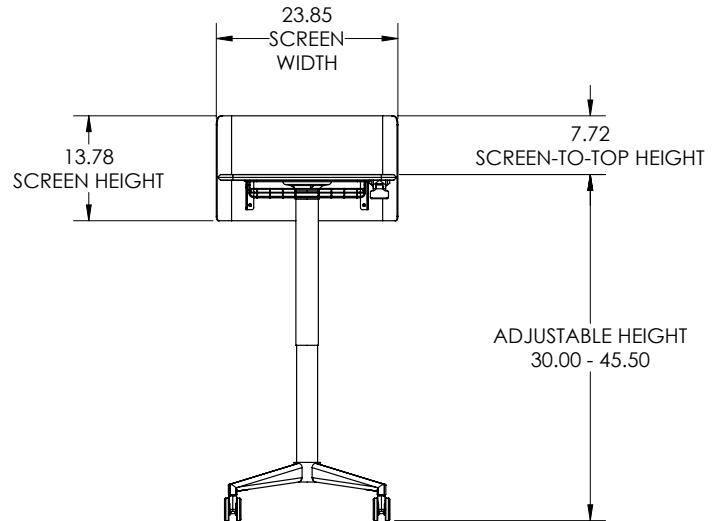

Model 26552 v
20"d x 23.5"w Rectangle top.

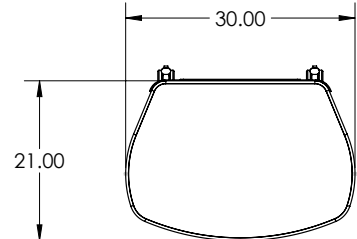

Model 26553 v
21"d x 30"w Oblong top.

LECTERN UNIT INSTALLED ACCESSORIES

*Model 26517 & Model 26518 are standard on the Sit + Stand Lectern Models 26552 & 26553.



Model 76517 *
Modesty Panel / Privacy Screen

Product Dimensions: 1.5"d x 23.625"w x 13.75"h
Freight Class: 40
Cube: 1.44
Carton Dimensions: 13.75"d x 26"w x 1.5"h
Weight: 5 lbs.

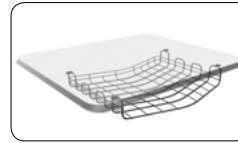

Model 76518 *
Technology Basket, low profile storage.

Product Dimensions: 10"d x 14"w x 3"h
Freight Class: 70
Cube: 1.44
Carton Dimensions: 10"d x 16"w x 3"h
Weight: 3 lbs.

Sit + Stand Column/Base Color



PLATINUM
PLT

Sit + Stand Has Top and Edge Choices

3/4" Tops



CHOICE 1

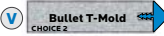

CHOICE 2

CHOICE 1 - 3/4" top with 4mm T-Mold
C to follow Model No.

CHOICE 2 - 3/4" top with Bullet T-Mold
V to follow Model No.

Standard Laminate Options

Want to specify a different laminate?

No problem. If you have 20 or more tops of the same color -60 or -38 there is no upcharge. Have 20 or less? We can quote for you with the Wilsonart code and - finish style. We can specify other laminates - call to inquire and get a quote.



Suggested Standard Laminates:

				
ASIAN NIGHT 7949-60 ANG	BOARDWALK OAK 7983-60 BWK	PEWTER MESH 4878-60 PEW	CLASSIC LINEN 4943-60 CLN	HIGH RISE 4996-60 HRE
				
BUKA BARK 7982-60 BBK	PALISADES OAK 7987-60 PSO	FLAX LINEN 4990-60 FLL	MISSION MAPLE 7990-60 MIM	NEW AGE OAK 7938-60 NEW

Classic Standard Laminates:

		
WILD CHERRY 7054-60 CHE	GREY NEBULA 4622-60 GNB	FUSION MAPLE 7909-60 MAP

All 13 of the standard laminates are -60 finish, if you need to match a laminate from a previous year, please let us know on your order (example Pewter Mesh 4878-38, our standard is -60).

When the WilsonArt Laminate code includes a "Y", "K", "-12" "-78", "Aeon" etc, these are special laminates with an upcharge, even when it contains -38 or -60.

Standard Edge Color Options

					
APPLE A	BLACK B	BLUEBERRY C	BURGUNDY D	CERULEAN S	CHAMPAGNE O
					
CHARCOAL R	CHOCOLATE Q	CLEMENTINE E	FOREST GREEN F	FUCHSIA G	MINT H
					
MOCHA T	NAVY I	ORANGE U	PERSIAN BLUE J	PLATINUM P	PURPLE K
					
RED L	YELLOW N				



cascade mini-case

with shelves

MODEL #: 11100000P_

MINI-CASE W/ SHELVES

OVERVIEW

The Cascade series provides storage for a wide variety of items. The Mini-Case is the smallest cabinet in the Cascade grouping, measuring in at 30 7/16" tall, 21" wide and 19" deep.

MATERIALS

The END PANELS are made of 18-gauge 1" square tubing, welded flush to an 18-gauge end panel. The inside of each end panel is reinforced by 22-gauge hat channels. These hat channels are dual purpose: added strength and for tote rail shelf mounting. The dome top is 18-gauge formed and welded construction, bolted to each end panel and rear panel with a total of 10 machine screw fasteners. The base is a durable 18-gauge steel construction formed and welded to support the entire weight of the unit squarely. Underneath is a heavy welded hat channel reinforcement. The base shelf is attached to both end panels using 4 machine screw fasteners. The Rear Panel is 18-gauge steel reinforced with up to three vertical hat channels. Two grommet holes (a lower and upper) are punched for convenient wire management and electronic storage. Casters are 4" in diameter, with 2 locking. Optional glides are 3/8" threaded stem.

RISER SHELVES are sized perfectly for each cabinet size. These riser shelves are made of 3/4" high density particle board with your choice of laminate and bullet T-Mold color. Shelf is suspended 6 inches above the dome top with 4 riser shelf handles, which measure 1 1/2" diameter and come in Platinum powder coat paint finish (0.03" Thickness). These riser shelf handles bolt on from underneath the dome top with a hefty 3" washer.

The optional DOORS include a secure and reliable locking mechanism, which engages lock rods into the dome top and the base shelf. Doors also come with urethane ergonomic and modern door handles of your color choice. The fully hinged doors articulate 270 degrees, free of obstruction.

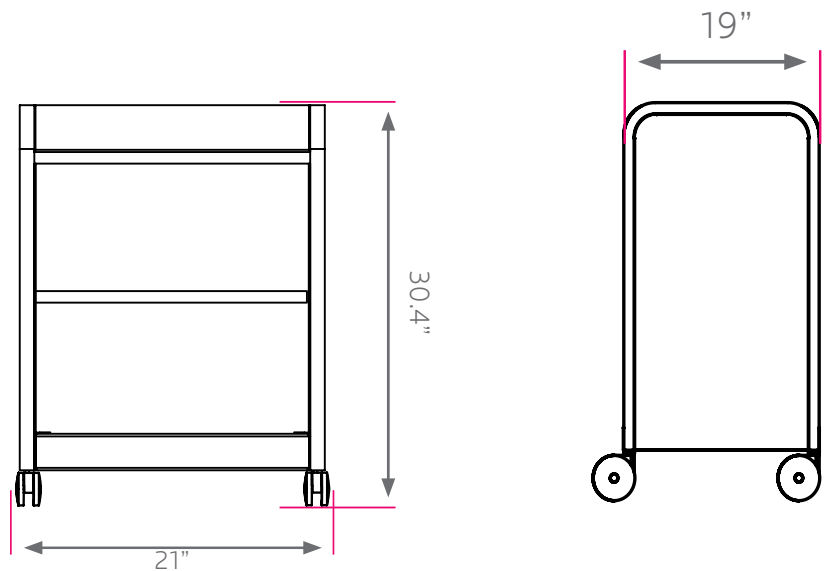

MINI-CASE W/ SHELVES

MODEL	DESCRIPTION	D"	W"	H"	F.C.	WT.
Shelves						
11100000P_	Open w/shelves	19	21	30.4	100	49
12100000P_	Door w/shelves	19	21	30.4	100	56
111V00000P_----	Open w/shelves & riser	19	21	37	100	65
121V00000P_----	Door w/shelves & riser	19	21	37	100	72
111L00000P_----	Open w/shelves & lectern	19	21	41.5	100	67
121L00000P_----	Door w/shelves & lectern	19	21	41.5	100	74
	pallet dimensions	26	26.5	32		



cascade mini-case

with totes

MODEL #: 110005000P_

MINI-CASE W/ EW TOTES

OVERVIEW

The Cascade series provides storage for a wide variety of items. The Mini-Case is the smallest cabinet in the Cascade grouping, measuring in at 30 7/16" tall, 21" wide and 19" deep.

MATERIALS

The END PANELS are made of 18-gauge 1" square tubing, welded flush to an 18-gauge end panel. The inside of each end panel is reinforced by 22-gauge hat channels. These hat channels are dual purpose: added strength and for tote rail shelf mounting. The dome top is 18-gauge formed and welded construction, bolted to each end panel and rear panel with a total of 10 machine screw fasteners. The base is a durable 18-gauge steel construction formed and welded to support the entire weight of the unit squarely. Underneath is a heavy welded hat channel reinforcement. The base shelf is attached to both end panels using 4 machine screw fasteners. The Rear Panel is 18-gauge steel reinforced with up to three vertical hat channels. Two grommet holes (a lower and upper) are punched for convenient wire management and electronic storage. Casters are 4" in diameter, with 2 locking. Optional glides are 3/8" threaded stem.

RISER SHELVES are sized perfectly for each cabinet size. These riser shelves are made of 3/4" high density particle board with your choice of laminate and bullet T-Mold color. Shelf is suspended 6 inches above the dome top with 4 riser shelf handles, which measure 1 1/2" diameter and come in Platinum powder coat paint finish (0.03" Thickness). These riser shelf handles bolt on from underneath the dome top with a hefty 3" washer.

The optional DOORS include a secure and reliable locking mechanism, which engages lock rods into the dome top and the base shelf. Doors also come with urethane ergonomic and modern door handles of your color choice. The fully hinged doors articulate 270 degrees, free of obstruction.



MINI-CASE W/ TOTES

MODEL	DESCRIPTION	D"	W"	H"	F.C.	WT.
<i>Extra Wide (EW) Totes</i>						
110005000P_	Open w/five 3" EW totes	19	21	30.4	100	52
120005000P_	Door w/five 3" EW totes	19	21	30.4	100	59
110V05000P_-----	Open w/five 3" EW totes & riser	19	21	37	100	69
120V05000P_-----	Door w/five 3" EW totes & riser	19	21	37	100	76
110L05000P_-----	Open w/five 3" EW totes & lectern	19	21	41.5	100	71
120L05000P_-----	Door w/five 3" EW totes & lectern	19	21	41.5	100	78
110003010P_	Open w/three 3" & one 6" EW tote	19	21	30.4	100	53
120003010P_	Door w/three 3" & one 6" EW tote	19	21	30.4	100	60
110V03010P_-----	Open w/three 3" & one 6" EW tote & riser	19	21	37	100	69
120V03010P_-----	Door w/three 3" & one 6" EW tote & riser	19	21	37	100	76
110L03010P_-----	Open w/three 3" & one 6" EW tote & lectern	19	21	41.5	100	73
120L03010P_-----	Door w/three 3" & one 6" EW tote & lectern	19	21	41.5	100	80
	pallet dimensions	26	26.5	32		

Cascade Frame



PLATINUM



Standard Laminate Options *(Casade Riser Shelves)

Want to specify a different laminate?

No problem. If you have 20 or more tops of the same color -60 or -38 there is no upcharge. Have 20 or less? We can quote for you with the Wilsonart code and – finish style. We can specify other laminates – call to inquire and get a quote.



Suggested Standard Laminates:



ASIAN NIGHT
7949-60
ANG



BOARDWALK OAK
7983-60
BWK



PEWTER MESH
4878-60
PEW

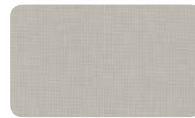

CLASSIC LINEN
4943-60
CLN



HIGH RISE
4996-60
HRE



BUKA BARK
7982-60
BBK



PALISADES OAK
7987-60
PSO



FLAX LINEN
4990-60
FLL



MISSION MAPLE
7990-60
MIM



NEW AGE OAK
7938-60
NEW

Classic Standard Laminates:



WILD CHERRY
7054-60
CHE



GREY NEBULA
4622-60
GNB



FUSION MAPLE
7909-60
MAP

All 13 of the standard laminates are -60 finish, if you need to match a laminate from a previous year, please let us know on your order (example Pewter Mesh 4878-38, our standard is -60).

When the WilsonArt Laminate code includes a "Y", "K", "-12" "-78", "Aeon" etc, these are special laminates with an upcharge, even when it contains -38 or -60.

Cascade End Panel and Edge Color Options



APPLE **A**



BLACK **B**



BLUEBERRY **C**



BURGUNDY **D**



CERULEAN **S**



CHARCOAL **R**



CHOCOLATE **Q**



CLEMENTINE **E**



FOREST GREEN **F**



FUCHSIA **G**



MINT **H**



MOCHA **T**



NAVY **I**



ORANGE **U**



PERSIAN BLUE **J**



PLATINUM **P**



PURPLE **K**



RED **L**



YELLOW **N**