



ALEDO ISD BOARD MEETING TEMPLATE

MEETING DATE: July 25, 2022

AGENDA ITEM: Consider Approval of Contingency Allowance Expenditure Authorization for 2019 Bond Project McAnally Middle School

PRESENTER: Earl Husfeld, Chief Financial Officer and Tyler Boswell, Director of Construction & Facilities

BACKGROUND INFORMATION:

- During the January 11, 2021 board meeting, the Board of Trustees approved the Competitive Sealed Proposal (CSP) submitted by Satterfield & Pontikes Construction, Inc. (S&P) in the amount of \$45,261,000.00 for the McAnally Middle School (Middle School No. 2) construction project.
- The contract amount of \$45,261,000.00 contains an Owner's Contingency amount of \$1,287,000.00.
- This Owner's Contingency amount is to be used by the District for unforeseen conditions, changes to the work, and/or for the betterment of the project. Any unused portion of Owner's Contingency must be credited to the District in calculating the final payment due.
- By contract, the Board of Trustees delegated authority to the Superintendent, or designee, to approve changes to the work, etc. where such changes are within the Owner's Contingency and do not exceed the amount of \$50,000.00.
- As we continue construction on this project, the following Contingency Allowance Expenditure Authorization (CAEA) has been brought forward that exceeds the \$50,000.00 threshold contained in the contract. Therefore, we are presenting the following CAEA to the Board of Trustees for consideration/approval:
 - CAEA #92 - Satterfield & Pontikes Construction, Inc. - \$72,474.00 - This CAEA is to furnish and install shades at interior storefronts, windows, and doors for all McAnally Middle School classrooms connecting to corridors.
- Huckabee, architecture firm for the McAnally Middle School construction project, and district staff have reviewed the backup material provided by S&P and costs associated with this CAEA and recommend acceptance.
- The acceptance/approval of this CAEA by the Board of Trustees will not cause the Owner's Contingency amount included within the construction contract to be exceeded.

FISCAL INFORMATION:

The total cost of \$72,474.00 for CAEA #92 will be allocated to Owner's Contingency for this construction project.



ALEDO ISD BOARD MEETING TEMPLATE

ATTACHMENTS:

S&P Construction Cost Documentation for CAEA #92

ADMINISTRATIVE RECOMMENDATION:

The Administration recommends the Board of Trustees approve Contingency Allowance Expenditure Authorization #92 in the amount of \$72,474.00 for the McAnally Middle School construction project as presented.



Change Proposal Request

Contractor:	Satterfield & Pontikes Construction, Inc.	CX#
CAEA	# 92	
CAEA Date:	7/15/2022	
Project:	52800	McAnally MS

Description
 Furnish and install additional shades at storefronts and doors to all classrooms connecting to corridors. Separate shades for doors due to conflict with door closers. Shades to match existing approved fabric in a blackout material.

CPR	
Type	Source
<input type="checkbox"/> A/E Error <input type="checkbox"/> A/E Omission <input checked="" type="checkbox"/> Scope Change <input type="checkbox"/> Unforeseen Condition	<input type="checkbox"/> Acceleration <input type="checkbox"/> Delay <input type="checkbox"/> A/E Request <input type="checkbox"/> GC Request <input type="checkbox"/> PM Request <input checked="" type="checkbox"/> Aledo ISD Request (Please Provide Name & Title)
	<input type="checkbox"/> Local Government Directive

Justification:

Cost Comparison	Amount	Days
Contractor's Initial Proposal	\$ 72,474.00	0
PM Estimated Amount		0
PM Recommended Amount		0

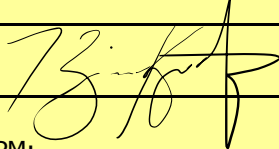
Recommendation & Approval	
PM: 	<input checked="" type="checkbox"/> Recommended <input type="checkbox"/> Not Recommended
Aledo ISD PM:	<input type="checkbox"/> Approved <input type="checkbox"/> Denied



Change Proposal - Contractor's Estimate

Dated 7/15/2022

CAEA NO.

92

PROJECT

McAnally MS

Subcontractor Cost

Material \$ 49,241.00

Labor \$ 23,233.00

Equipment \$ -

Subtotal \$ 72,474.00

Subcontractor's Overhead & Profit \$ -

Total Cost for Subcontractor

\$ 72,474.00

General Contractor Cost

Material \$ -

Labor _____

Equipment _____

Subtotal General Contractor Cost

\$ -

Subtotal Cost for General Contractor & Subcontractor

\$ 72,474.00

TIME EXTENSION IN DAYS (FOR THIS CHANGE)

0

General Contractor Signature

Dated 7/15/2022

A/E Signature _____

Dated _____



Change Proposal - Cost Detail

Project: McAnally MS

Contractor: Satterfield and Pontikes Construction

CPR # # 92		Material				Labor Burden			0%	Equipment / Subcontractor				Subtotal	Markup	Total	
Item	Description	Unit	Qty	Material Unit Cost	Total Material Cost	Hours	Unburdened Labor	Labor Burden Amount	Total Labor Cost	Unit	Qty	Equipment Unit Cost	Total Equipment Cost	Cost Material, Labor & Equipment	Overhead, Profit & Bond	Cost Material, Labor & Equipment	
1	M4 Specialties - Furnish and install additional shades at all classrooms connecting to corridors and shades at all doors to classrooms				\$48,241.00				\$ 13,633.00					\$ 61,874.00		\$ 61,874.00	
2	Cleanup post installation for each room								\$ 7,100.00					\$ 7,100.00		\$ 7,100.00	
3	Supervision for after hours work								\$ 2,500.00					\$ 2,500.00		\$ 2,500.00	
4	Floor Protection				\$ 1,000.00				-					\$ 1,000.00		\$ 1,000.00	
														-		-	
														-		-	
														-		-	
														-		-	
Total Change Proposal Cost					\$ 49,241.00				\$ 23,233.00					\$ -	\$ 72,474.00	\$ -	\$ 72,474.00



SPECIALTY COMPANY

Change Order

Printed: Jul 8, 2022
1200 Placid Avenue, Suite 600, Plano, TX 75074
Phone: 972-535-5544

Owner Info

Owner (2012036 - Aledo ISD Middle School #3)

Job Info

14700 Old Weatherford Road
Aledo, TX 76008

Change Order ID
2012036-0004

2012036 - Aledo ISD Middle School #3

CO ID	Created / Approved Date	Price
2012036-0004	Created: Jul 8, 2022 Pending...	\$61,874.00

Description
<p>Door Shades - CO 01 - REV 07/08/22 REVISED COST CHANGE 07/08/2022: Cost to furnish and install additional blackout shades at interior storefront leading to classrooms. Cost includes one shade at all locations with exception for MM storefronts, where two shades will be installed. 75 Shades in total. Cost includes back cover since shades will be mounted to ceiling. This will ensure all sides of the shades are covered. Blocking and support for shade attachment by others.</p> <p>ALTERNATE MANUFACTURE SHADE COST = \$49,169.00 ADD FOR SUPPORT ABOVE CEILING = \$12,705.00 <u>TOTAL CHANGE COST = \$61,874.00</u></p> <p style="color: green; text-align: center;">Alternate Shades approved from WT.</p> <p>PLEASE NOTE: As stated above, this cost is for the alternate WT Shade manufacture. Samples and PD have been provided for review.</p> <p>If Owner/GC/Design wishes to go with the specified manufacture, please ADD \$59,464 to pricing provided on this CO dated 7/08/2022.</p>

Items	Cost Types	Description	Qty / Unit	Unit Price	Price
Alternate Shades w/ Ceiling Support 122400 Manual Shades	Material		1	\$48,241.00	\$48,241.00
Alternate Shades w/ Ceiling Support 122400 Manual Shades	Labor		1	\$13,633.00	\$13,633.00

Status	Signature	Date
Approved by: _____		__/__/__

Approval Comments

Please Note: A signature of Approval OR **Electronic Acceptance** is required before change order is effective. This change order becomes part of the existing contract.

TOTAL AMOUNT OF CHANGE ORDER: \$61,874.00



MORE THAN ARCHITECTS

SUBSTITUTION REQUEST FORM

Architect Project No: _____

Bid Date: _____

Date of Request: 06/24/22

Project Name: MCANALLY MIDDLE SCHOOL

SUBSTITUTION REQUEST BY:

Firm: M4 Specialty Company

Address: 1200 Placid Road, Plano, TX 75074

Phone: _____

Fax: _____

We hereby request that the following Substitution be allowed in lieu of the Product specified on the above project.

ARCHITECT / ENGINEERS RESPONSE:

APPROVED APPROVED AS NOTED

NOT APPROVED SUBMITTED TOO LATE

FAILED TO PROVIDE ADEQUATE INFORMATION

REMARKS: APPROVED FOR SECURITY SHADE LOCATIONS ONLY
SELECTED COLOR: 762-80 GRAY

BY: J.COGBURN DATE: 07.01.22

SPECIFIED PRODUCT SWF

SPECIFICATION SECTION 12000

PROPOSED PRODUCT SUBSTITUTION WT SHADE

This request includes the following: attached Technical Data, Laboratory Tests and proposed changes to the Drawings and Specifications, which the proposed Substitution will require for proper installation.

PRODUCT DATA, SPECS. PHYSICAL SAMPLES SENT TO ARCH FOR APPROVAL.

The Firm requesting the Substitution agrees to pay for changes to the building design, including Architectural, Engineering, and detailing costs caused by the requested Substitution. YES NO NOT APPLICABLE

What effect does the Substitution have on other trades? N/A

What effect does Substitution have on Construction Schedule? N/A

Differences between proposed Substitution and specified item? PROPOSED MANUFACTURE IS HALF THE COST OF SPECIFIED.
PROPOSED HAS A BACK COVER TO ALLOW FOR SHADE TO BE FULLY CONCEALED.

Manufacturer's guarantees of the proposed and specified items are: X - OPERATION/WARRANTY Same FEATURES (BACK COVER) Different (If different, explain on attachment)

The undersigned state that the function, appearance and quality are equivalent or superior to the specified item.

SIGNATURE

PROJECT MANAGER

TITLE

6/24/2022

DATE

Huckabee

AUSTIN • DALLAS • FORT WORTH • HOUSTON • SAN ANTONIO • WACO

www.huckabee-inc.com

HeliaRISE® H300 SoloMOUNT® SYSTEM

MANUAL ROLLER SHADE • FASCIA COMPATIBLE • MEDIUM-LARGE SIZE SHADES

New York 11040

HELIARISE®

{T} 877.294.3580 • {F} 516.294.0444 • {E} info@WTShade.com • 77 Second Avenue • Garden City Park.

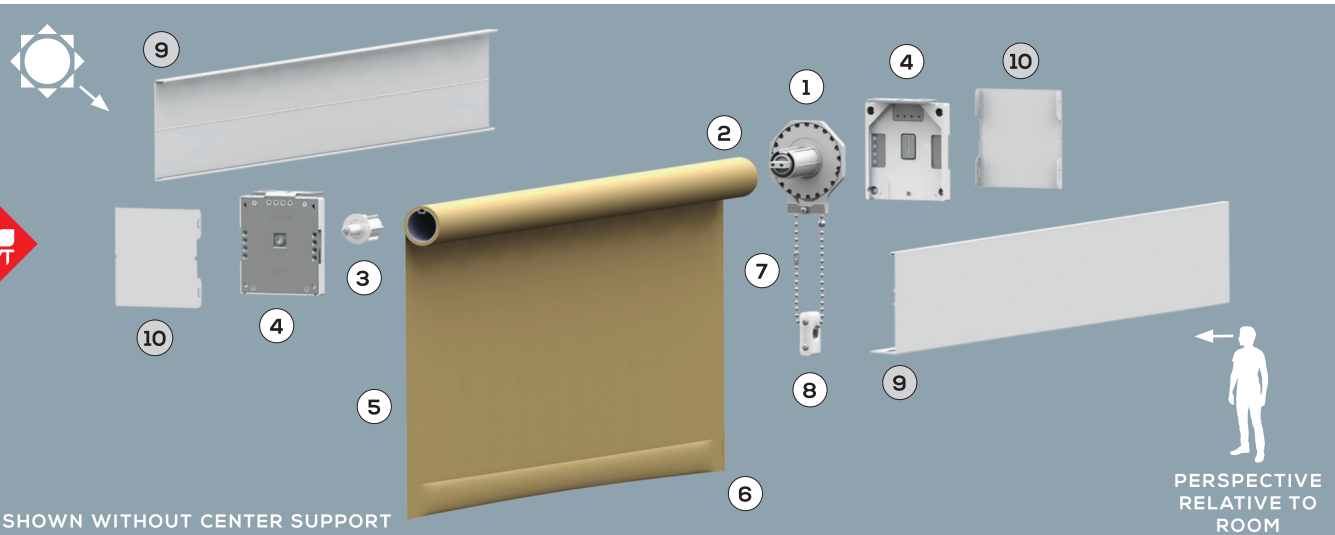

The above system is shown Model H300SM-1.5 Drive Right, Regular Roll with Front Fascia and Rear Fascia. Brackets shown in Ceiling Mount position.

MODELS:
H300SM-1.5
H300SM-2.0
H300SM-2.38

ADDITIONAL INFORMATION

STANDARD COMPONENTS		
1	CLUTCH	Available in White (-10) as shown, or Black (-90) and will be color coordinated based on fabric color.**
2	ROLLER TUBE	May contain 1.5", 2" or 2.38" Diameter tube. Content: Aluminum Alloy.
3	IDLER	Retractable. Available in White (-10) as shown, or Black (-90) and will be color coordinated based on fabric color.** Systems with SAM will have HD Idler.
4	SoloMOUNT BRACKETS	Ships preset for Ceiling/Jamb or Wall Mounting for Drive Right or Drive Left. Available in White (-10) as shown, or Black (-90) and will be color coordinated based on fabric color. **
5	FABRIC	See fabric selection for all available options.
6	SEALED HEMBAR	Alternative options available including external, round or heavy duty styles. May require alternative hembar for some accessory compatibility.
7	STAINLESS STEEL DRIVE CHAIN	Includes matching Bead Stops. Alternative materials and colors available.
8	CHILD SAFETY TENSION DEVICE	Available in White (-10) as shown, or Black (-90) and will be color coordinated based on fabric color.**
OPTIONAL		
9	4.5" FASCIA	Available for Front & Rear application for Regular or Reverse Roll. Available in White (-10) as shown, Ivory (-04), Silver (-20), Bronze (-50) or Black (-90).
10	END CAPS	Available in White (-10) as shown, Ivory (-04), Silver (-20), Bronze (-50) or Black (-90).
11	CENTER SUPPORT INCLUDES CENTER SUPPORT BRACKET, TANGS AND FORKS.	Multibanded option available up to 3 bands. Can be Ceiling or Wall Mounted. Drive Right or Drive Left. Available in White (-10) as shown, or Black (-90) and will be color coordinated based on fabric color.**

SHOWN WITH CENTER SUPPORT

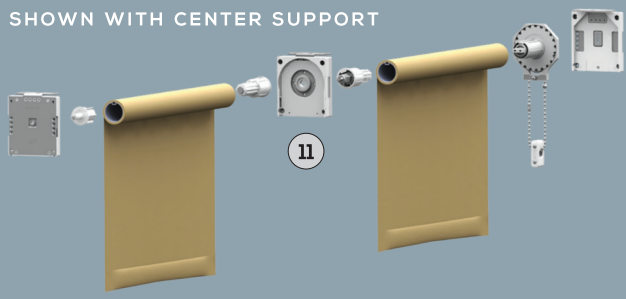

OPTIONAL		
N/A	SAM SPRING ASSIST MECHANISM MIN SHADE WIDTH: 37½"	(Not Shown) May be added to any system to decrease the pulling force necessary to operate the shade. Drive Right or Drive Left.
N/A	WALL MOUNT ANGLE	(Not Shown) Required for Wall Mount applications with Rear Fascia. Size: 4¾" x 4¾" x 1¼"



**See Color Coordination Guide for more information.



SYSTEM FEATURES

- ◆ Featuring our proprietary, all-in-one **SoloMount Brackets**: Ceiling, Wall or Jamb mount capable allowing easy, on-the-fly adjustments. Mounting flange is extendible up to 3/8" for Wall Mount applications.
- ◆ Available with Front Fascia, Rear Fascia or Both! Regular and Reverse Roll available. Clutch may be Drive Right or Drive Left.
- ◆ **SoloMount Brackets** are designed to accept fascia at the time of order or at any point in the future.
- ◆ HeliaRise Clutches feature an integrated stainless steel reinforced Chain Diverter and Set-Screw for maximum stability and durability.
- ◆ Metal to metal contact points on both the Drive and Idle sides of the shade ensure a sturdy and reliable connection to the brackets.
- ◆ Some HeliaRise components are available in White (-10) and Black (-90). WT Shade will color coordinate based on the selected fabric color. Refer to the *Color Coordination Guide* for more information.
- ◆ HeliaRise Shading Systems offer multiple options and accessories, including various Hembar styles and Drive Chain colors.
- ◆ All WT Shade roller shades are available in the *exclusive* line of sustainable solar protection fabrics by EcoFabrix®. To view all available fabrics, visit EcoFabrix.com.
- ◆ Construction Documents for this system and others available at WTShade.com.

SECTION VIEW

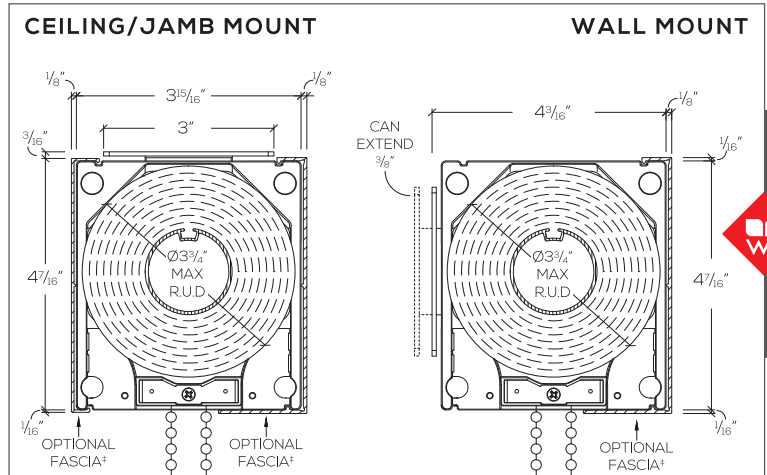

‡ Front and Rear Fascia is able to be used in Ceiling or Jamb Mount applications. Wall Mount applications with Rear Fascia require the use of Wall Mount Angles (Not Shown).

EDGE CLEARANCES

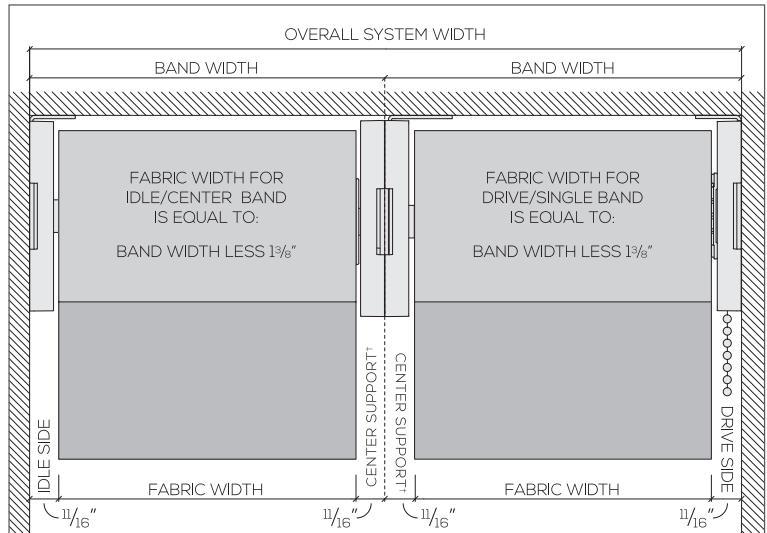

† For systems containing the RS23W-99 tube, add 5/16" to each center support deduction.

SYSTEM CAPABILITIES

WIDTH	60"	72"	84"	96"	108"	120"	132"	144"
LENGTH	180"	180"	180"	180"	180"	180"	162"	132"

Width and Length may vary depending on the selected shade fabric. The measurements given above are based on EcoFabrix 253. These measurements are for guideline purposes only and in no way guarantee that a shade with any other fabric can be made to these dimensions.

WARNING

ADVERTENCIA

Bead Chain can STRANGLE Your Child.

To prevent strangulation, purchase cordless products or products with inaccessible cords.

ANSI/WCMA A100.1-2018

La cuerda ciega de la ventana puede ESTRANGULAR su niño.

Para evitar el estrangulamiento, compre alternativas inalámbricas o productos con cables inaccesibles.

THE SoloMount BRACKET®
One bracket... So many possibilities.



HeliaRISE®
MANUAL SHADING SYSTEMS



WT SHADE LIMITED WARRANTIES

WT Shade (“WT Shade,” “we,” “our,” or “us”) offers limited warranties on its Goods (“Goods” or “products”) that vary in duration (“Warranty Period”), scope, terms, and conditions depending on the type of product (each, a “Limited Warranty” and collectively, “Limited Warranties”). Such Limited Warranties are set forth below and are incorporated by reference into and governed by the executed Windowcraft, Inc. (“Windowcraft”) General Terms and Conditions for the Sale of Goods between Windowcraft and Buyer (“Buyer,” “purchaser,” “you,” or “your”). All Orders and sales of products are governed by the executed Windowcraft General Terms and Conditions for the Sale of Goods between Windowcraft and Buyer, and the Limited Warranties set forth below shall only apply to your Orders after your signed agreement to the Windowcraft General Terms and Conditions. These Limited Warranties may be amended, revised, and/or updated by Windowcraft from time to time without notice, as applicable and as reasonably necessary. All *capitalized terms* not otherwise defined on this page *shall have the meaning* as set forth in the executed Windowcraft General Terms and Conditions for the Sale of Goods between Windowcraft and Buyer. A copy of the Windowcraft General Terms and Conditions for the Sale of Goods is available on Windowcraft’s website.

The Diamond Standard: WT Shade Limited Lifetime Warranty

At WT Shade, we believe that a purchaser should feel confident and secure that the WT Shade products they have chosen will last for many years to come, and that is why we are proud to offer The Diamond Standard: WT Shade Limited Lifetime Warranty which covers HeliaRise® Manual Shading Systems, MotoRise® Motorized Shading Systems, and certain other WT Shade shading products and accessories (as specifically indicated below).

For any individual Order containing any of the WT Shade products in the chart that immediately follows, we warrant that for a Warranty Period of up to twenty-five (25) years following shipment of each such product you have purchased, each such WT Shade product will (a) materially conform to the Product Specifications in effect as of the date of shipment, and (b) will be free from material defects in material or workmanship, including any system or shade hardware; **provided that** certain system components and Third Party Products (as defined below), including electrical components (such as batteries and wiring), fabrics, and bead chains that are not manufactured by WT Shade, as well as the **Exclusions** defined for each specific WT Shade product in the chart that immediately follows, are expressly excluded from and not covered by this WT Shade Limited Lifetime Warranty, but may be covered by the original manufacturers’ own warranty or a separate warranty as specifically otherwise indicated herein.

WT SHADE PRODUCT	LIMITED WARRANTY PERIOD	LIMITED WARRANTY EXCLUSIONS
HeliaRise® Manual Shading Systems	25 Years	Fabric. Bead Chain.
MotoRise® Motorized Shading Systems	25 Years	Fabric.
Wrapped Fixed Frame Panels (manufactured by WT Shade)	25 Years	Fabric.
WT Shade Shading Accessories (manufactured by WT Shade)	25 Years	Fabric. Bead Chain.

In the unlikely event a WT Shade product is found to not meet this WT Shade Limited Lifetime Warranty (subject to the conditions set forth in the Windowcraft Terms and Conditions for the Sale of Goods), WT Shade will replace or repair any item found to contain material defects in material or workmanship at the time the WT Shade product was manufactured by WT Shade. However, if a product is found to have been improperly installed, abused, or subject to any use other than that which it was originally intended, the product may no longer be eligible for a warranty claim. Additionally, although this WT Shade Limited Lifetime Warranty does not cover normal wear and tear of the particular product, which is expected over the course of ownership, and in no way guarantees that WT Shade products are indestructible, we pledge to each of our customers that we will do everything within reason to ensure complete satisfaction.

Fabric Limited Warranties

For any individual Order containing any of the WT Shade Fabric products in the chart that immediately follows, we warrant that for a Warranty Period of up to ten (10) years following shipment of each such product you have purchased, each such WT Shade Fabric product will (a) materially conform to the Product Specifications in effect as of the date of shipment, and (b) will be free from material defects in material or workmanship; **provided that** fabrics provided by the customer (COM), fabrics not listed in the chart that immediately follows, and the **Exclusions** defined

for each specific WT Shade Fabric product in the chart that immediately follows are expressly excluded from and not covered by this Limited Warranty, but may be covered by the original manufacturers' own warranty.

WT SHADE FABRIC	LIMITED WARRANTY PERIOD	LIMITED WARRANTY EXCLUSIONS
Ecofabrix® 250, Ecofabrix® 251, Ecofabrix® 253, Ecofabrix® 255, Ecofabrix® 315, Ecofabrix® 351, Ecofabrix® 353, Ecofabrix® 355, Ecofabrix® 363, Ecofabrix® 441, Ecofabrix® 450, Ecofabrix® 453, Ecofabrix® 455, Ecofabrix® 700, Ecofabrix® 740, Ecofabrix® 772, and Ecofabrix® 840	10 Years	Normal wear and tear; cleaning; damage from misuse or abuse; improper installation; exposure to the elements; or dye-lot variations.
Mermet® Avila Twilight, Mermet® Chroma™, Mermet® E Screen, Mermet® Flocke®, Mermet® T Screen, and Mermet® Vizela	10 Years	Normal wear and tear; cleaning; damage from misuse or abuse; improper installation; exposure to the elements; or dye-lot variations.

Third Party Products

For each and every Order, products manufactured by a third party (“Third Party Product”) may constitute, contain, be contained in, incorporated into, attached to or packaged together with, the products you have purchased. Such Third Party Products include, but are not limited to, motors, motor accessories, power supplies, batteries, electrical components, fabrics, and bead chains. WT Shade assumes no liability and expressly provides no warranty on any Third Party Product included in or with any WT Shade product, including any WT Shade Manual Shading System or Motorized Shading System. Each Third Party Product is governed by the applicable warranty set forth by the original manufacturer, if any, and the limitations and conditions set forth therein. For specific information about motor warranties for any WT Shade Motorized Shading System, please contact the motor manufacturer.

Disclaimer

EXCEPT FOR THE APPLICABLE LIMITED WARRANTIES SET FORTH ABOVE, WINDOWCRAFT MAKES NO WARRANTY WHATSOEVER WITH RESPECT TO THE GOODS, INCLUDING ANY (A) WARRANTY OF MERCHANTABILITY OR (B) WARRANTY OF FITNESS FOR A PARTICULAR PURPOSE WHETHER EXPRESS OR IMPLIED BY LAW, COURSE OF DEALING, COURSE OF PERFORMANCE, USAGE OF TRADE OR OTHERWISE. WINDOWCRAFT DISCLAIMS ALL, AND ASSUMES NO LIABILITY FOR, THE NONPERFORMANCE OF INCOMPATIBLE SYSTEM COMPONENTS OR ACCESSORIES OF ANY GOODS.

Notwithstanding the foregoing, Third Party Products are not covered by the Limited Warranties set forth above. For the avoidance of doubt, WINDOWCRAFT MAKES NO REPRESENTATIONS OR WARRANTIES WITH RESPECT TO ANY THIRD PARTY PRODUCT, INCLUDING ANY (a) WARRANTY OF MERCHANTABILITY; (b) WARRANTY OF FITNESS FOR A PARTICULAR PURPOSE; (c) WARRANTY OF TITLE; OR (d) WARRANTY AGAINST INFRINGEMENT OF INTELLECTUAL PROPERTY RIGHTS OF A THIRD PARTY; WHETHER EXPRESS OR IMPLIED BY LAW, COURSE OF DEALING, COURSE OF PERFORMANCE, USAGE OF TRADE OR OTHERWISE.

HOW TO MAKE A WARRANTY CLAIM

If you have a WT Shade product that you believe is defective due to a material defect in the material, workmanship or craftsmanship of the product, please follow these steps to make a warranty claim under a WT Shade Limited Warranty:

NOTE TO END USERS: Contact your shading installer or dealer. It is important and strongly advised that you have your product inspected by a professional shading installer. Many times a professional installer will be able to make an adjustment or repair on-site, and will not have to remove and send back your product. However, if your installer is not able to repair the issue, the product must be removed and sent back to us for inspection. It is important that the removal and handling of the shade be done by a shading professional in order to ensure that no additional damage is done that could void your warranty. If you are not the original purchaser of the WT Shade product, and the product was purchased through any other party, including a window shade dealer, window shade manufacturer, window shade reseller or window shade installer, you must first contact that party in order to make a claim under a WT Shade Limited Warranty.

1. Locate the order number associated with the product: In order to make a warranty claim, WT Shade MUST be provided with the original order number (often times called the “W Number”) for the defective product. This number will begin with a “W,” and can be found on the ID tag located on the product. For all WT Shade Shading Systems, this ID tag can be found on the aluminum tube of the shade, and can be accessed by completely unrolling the shade fabric and exposing the tube. It is important that the removal and handling of the shade be done by a shading professional in order to ensure that no additional damage is done that could void your warranty. We also recommend taking a photograph of the tag, so that you or the original purchaser can continue to refer to it later or to send to us.

2. Contact WT Shade Immediately: Once you have obtained the order number, WT Shade should be contacted by the original purchaser to make a claim under a WT Shade Limited Warranty. The original purchaser should call Customer Service at (877) 294-3580 or email customerservice@wtshade.com. Once WT Shade has recorded the claim, the original purchaser will be furnished with a Return Goods Authorization Number (“RGA”). This number will be used to track the status of the claim and will be used to identify any products that have been returned to us.

3. Return the defective items to WT Shade: In order to repair or replace the defective item, WT Shade will need to inspect the product to determine the cause of the issue. In order to do so, the shading product must be uninstalled and packaged for shipping. If you do not feel comfortable performing such uninstallation, please contact your shading installer for help. WT Shade will not be liable or responsible for the costs or potential damage of the uninstallation, the materials used to package the product, or the shipping costs to return the product to us. All boxes and packages sent to WT Shade in regard to the claim MUST be marked with the corresponding RGA number. Items received with no RGA number will be returned to sender. Please send all returns to:

77 Second Ave
Garden City Park, NY 11040
ATTN: WARRANTY
RGA#: _____

4. Inspection of the Return: Within a reasonable time after receipt, WT Shade will inspect the returned product, perform an inspection, and determine the nature of any defect. We will then contact the original purchaser to discuss the results of WT Shade’s investigation.

- If the product has been determined to be covered by this warranty, WT Shade will fully repair or replace the defective part or component. If a replacement part has already been sent to the original purchaser, there will be no charges added to the corresponding account.

- If it is determined that the defect has been caused by damage or misuse, and/or is found to not be protected by this warranty, WT Shade will contact the original purchaser to discuss the necessary repairs needed to fix the defect, which may require new parts, shipping and/or labor at additional costs. Any replacement parts that have been sent to the original purchaser prior to WT Shade’s inspection may also incur additional charges to your account.

Questions? If at any time you have questions about this warranty or how to make a warranty claim, please contact WT Shade Customer Service at (877) 294-3580 or email customerservice@wtshade.com.



X X
713

762-80 Gray

Openness: 0%
Available up to 118"
Content: Polyester

